

**Circuits  
from the Lab®**  
Reference Designs

*Circuits from the Lab® reference designs are engineered and tested for quick and easy system integration to help solve today's analog, mixed-signal, and RF design challenges. For more information and/or support, visit [www.analog.com/CN0352](http://www.analog.com/CN0352).*

| Devices Connected/Referenced |  |
|------------------------------|--|
| <a href="#">ADP5065</a>      | Fast Charge Battery Manager with Power Path and USB Compatibility                        |
| <a href="#">ADG715</a>       | CMOS, Low Voltage Serially Controlled, Octal SPST Switch                                 |
| <a href="#">AD8601</a>       | Precision CMOS, Single-Supply, Rail-to-Rail, Input/Output Wideband Operational Amplifier |
| <a href="#">AD8237</a>       | Micropower, Zero Drift, True Rail-to-Rail Instrumentation Amplifier                      |
| <a href="#">AD8275</a>       | G = 0.2, Level Translation, 16-Bit ADC Driver  |
| <a href="#">AD8276</a>       | Low Power, Wide Supply Range, Low Cost, Unity-Gain Difference Amplifier                  |
| <a href="#">ADuCM360</a>     | Low Power, Precision Analog Microcontroller with Dual Sigma-Delta ADCs, ARM Cortex-M3    |

## Cost Effective, Multichannel Lithium Ion Battery Testing System

### EVALUATION AND DESIGN SUPPORT

#### Circuit Evaluation Boards

**CN-0352 Evaluation System (EVAL-CN0352-EB1Z)**

Evaluation system includes

**EVAL-CN0352-EB1Z\_IO (Input/Output Board, 8 Each)**

**EVAL-CN0352-EB1Z\_MCU (MCU Board, 1 Each)**

**EVAL-CN0352-EB1Z\_BAS (Base Board, 1 Each)**

#### Design and Integration Files

[Schematics](#), [Source Code](#), [Layout Files](#), [Bill of Materials](#)

### CIRCUIT FUNCTION AND BENEFITS

The test system shown in Figure 1 is an accurate, cost effective, 8-channel battery testing system for single-cell, lithium ion (Li-ion) batteries with open circuit voltage (OCV) between 3.5 V and 4.4 V.

The demand for Lithium ion (Li-ion) batteries is high for use in both low power and high power applications, such as laptop computers, mobile phones, portable wireless terminals, as well as hybrid electric vehicles/all-electric vehicles (HEV/EV). Li-ion batteries therefore require accurate and reliable test systems.

The battery test system in Figure 1 is composed of multiple input/output boards (EVAL-CN0352-EB1Z\_IO) for handling the charging and discharging process, an MCU board (EVAL-CN0352-EB1Z\_MCU) for battery data acquisition, testing,

monitoring, and temperature management, and a backplane base board (EVAL-CN0352-EB1Z\_BAS) that provides the signal interconnections between the MCU board and the multiple input/output boards.

The circuit uses the [ADP5065](#) fast charging battery manager for flexible, efficient, high stability charging control with low cost, small printed circuit board (PCB) area, and ease of use compared to traditional discrete solutions.

Highly integrated precision data acquisition and processing is provided by the [ADuCM360](#) precision analog microcontroller. The [ADuCM360](#) acquires the battery voltage, current, and temperature. A high precision analog-to-digital converter (ADC), digital-to-analog converter (DAC), and an on-chip microcontroller allows completely self-contained control of the charging and discharging process.

The analog front end is fully differential with high CMRR and excellent immunity to both common-mode and ground noise caused by large currents generated during the charge and discharge cycles.

The number of channels can easily be expanded to further reduce testing time and cost per battery.

#### Rev. A

Circuits from the Lab® reference designs from Analog Devices have been designed and built by Analog Devices engineers. Standard engineering practices have been employed in the design and construction of each circuit, and their function and performance have been tested and verified in a lab environment at room temperature. However, you are solely responsible for testing the circuit and determining its suitability and applicability for your use and application. Accordingly, in no event shall Analog Devices be liable for direct, indirect, special, incidental, consequential or punitive damages due to any cause whatsoever connected to the use of any Circuits from the Lab circuits. (Continued on last page)

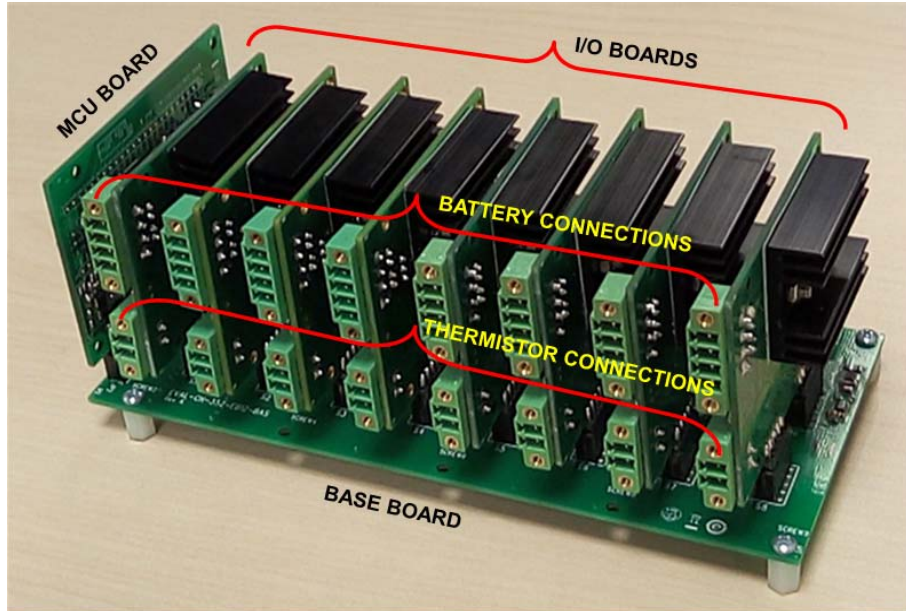

Figure 1. Cost Effective, Multichannel Li-ion Battery Testing System

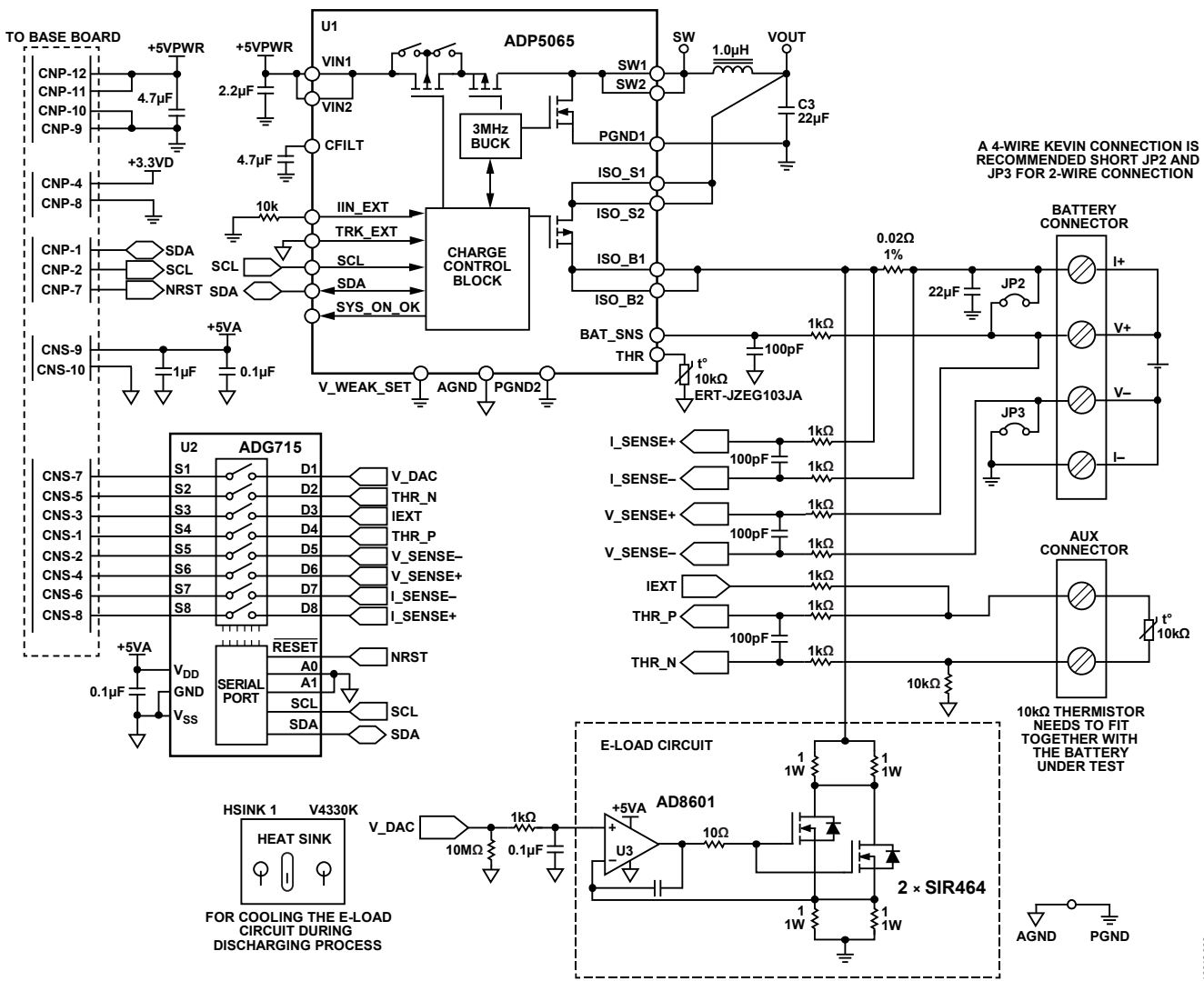

Figure 2. EVAL-CN0352-EB1Z\_IO, Li-ion Battery Charging and Discharging Controlling Circuit (Simplified Schematic: All Connections and Decoupling Not Shown)

12842-002

## CIRCUIT DESCRIPTION

The 8-channel battery testing system (EVAL-CN0352-EB1Z) contains eight input/output boards (EVAL-CN0352-EB1Z\_IO) and one MCU board (EVAL-CN0352-EB1Z\_MCU) that plug into one base board (EVAL-CN0352-EB1Z\_BAS). The circuit shown in Figure 2 is the input/output board.

### Input/Output Board (EVAL-CN0352-EB1Z\_IO) Description Battery Charging Control Using the ADP5065

The ADP5065 handles all the necessary charging control for single cell Li-ion or lithium polymer batteries, including the constant current (CC), constant voltage (CV), and trickle charge (TC) modes. The TC mode allows testing a deeply discharged battery and ensures safety. The ADP5065 uses a dc-to-dc switching converter architecture for high efficiency during the charging process, compared to more traditional linear regulators.

The ADP5065 integrates a number of significant features to guarantee the high reliability including thermal management, battery fault detection, and fault recovery.

The charging parameters of ADP5065, such as fast charging current, charging termination current, and charging termination voltage, are all programmable through an I<sup>2</sup>C interface. This programmability allows the ADP5065 to operate with many different types of Li-ion batteries as well as to operate as a complete battery charging and test controller.

### Battery Discharging Control and Electronic Load (E-Load) Circuit

The electronic load (E-load) circuit within the dashed rectangular block in Figure 2 provides a programmable constant-current load that uses the AD8601 precision CMOS op amp, four 1 W, 1% power resistors, and two power SIR464 MOSFETs.

The E-load current is accurately controlled by the control voltage on the noninverting input of AD8601. The control voltage (V\_DAC from MCU board) can range from 0 V to 1 V, which produces a load current of 0 A to 2 A. The typical discharging termination voltage for Li-ion battery is 3.0 V. The minimum allowable output voltage required by this E-load is

$$2 \text{ A} \times 1 \text{ } \Omega = 2 \text{ V}$$

The power MOSFETs and the power resistors consume all the energy from the battery during discharging process. The cooling system implemented in this module is only for demonstration purposes, and additional attention is required to guarantee adequate cooling performance when the discharging current is higher than 750 mA.

Because the on-resistance of MOSFETs have a positive temperature coefficient, multiple devices of the same type can be used in parallel and controlled by a single loop shown as the E-circuit in Figure 2. This is a common way to extend the power handling ability of power MOSFET circuits.

The sample-and-hold circuits shown in Figure 3 control the discharging voltage on each channel. The ADuCM360 refreshes the discharging voltages of the input/output board sequentially by outputting the preconfigured discharging control voltage for each channel and then turning on the corresponding ADG715 switch.

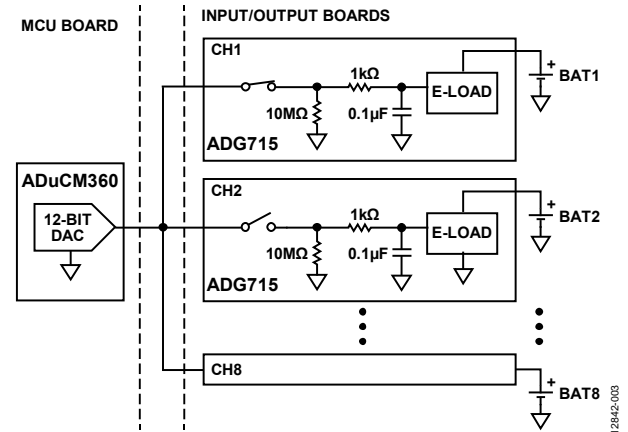

Figure 3. Sample-and-Hold Circuit for Multichannel Discharging Current Control Circuit

Only one input/output board has its ADG715 switch closed at any given time. The 0.1 μF capacitor is charged by the DAC through a 1 kΩ resistor during the sampling interval and discharged through the 10 MΩ resistor the 1 kΩ to ground during the holding interval. The bandwidths for charging and discharging are approximately 1.6 kHz and 0.16 Hz, respectively. The 10 MΩ resistor is required to discharge the voltage on the 0.1 μF capacitor and pull the discharging voltage close to ground if there is no MCU board connected.

Assuming an N-channel system and a sampling and holding time of  $T_s$  and  $T_H$ , respectively, the following condition must be met:

$$T_H = T_s (N - 1).$$

Therefore more channels require a longer holding time, and the leakage current produces a larger droop voltage. For the CN-0352 system,  $N = 8$ ,  $T_s = 1 \text{ ms}$ , and  $T_H = 7 \text{ ms}$ , and the droop voltage is negligible.

### Thermal Management

Most Li-ion batteries cannot be charged at temperatures lower than 0°C or above 60°C. Fast charging and discharging can only be performed from 10°C to 45°C.

In addition to safety issues, the performance of the Li-ion cell can change dramatically with temperature. Therefore, the temperature of the battery needs to be measured with proper accuracy to ensure the repeatability of the test results and also to guarantee safety.

Battery temperature is monitored using 10 kΩ thermistors connected to the temperature connector blocks with a 2-wire connection. The battery under test is usually located near the board, therefore the thermistor lead resistance is negligible.

There is another 10 kΩ thermistor on the input/output board connected to the THR pin of ADP5065 as shown in Figure 2.

This thermistor is for monitoring the temperature near the heat sink on the input/output board, because the temperature can be relatively high during discharging. The thermistor temperature information is sensed and stored in the ADP5065 Charger Status Register 2 and is monitored by the MCU board through the I<sup>2</sup>C bus. There are two headers on the input/output board for the external fan connections with configurable pulse-width modulation (PWM) signals assigned. If the thermistor temperature is less than 45°C, the PWM signal to the fans is set at 50% duty cycle by the MCU. If the temperature is greater than 45°C the duty cycle is increased to 95%. If the temperature is greater than 60°C the ADP5065 automatically stops the charging process. The temperature thresholds can be fine tuned by placing a fixed resistor in parallel or in series with the thermistor.

**Battery Connection and Sensing**

The battery under test is connected to the input/output board by a 4-wire Kelvin connection to eliminate errors caused by lead resistance. The I+ and I- connecting wires must have low lead

resistance to carry the charging and discharging current. The V+ and V- lines sense the voltage of battery and carry only a small bias current. The charging and discharging current is sensed by measuring the voltage across the 0.02 Ω, 1% current sense resistor.

All the battery information is sensed differentially to increase the robustness and reduce the common-mode error, which is very important because of the large ground currents during charging and discharging.

**MCU Board (EVAL-CN0352-EB1Z\_MCU) Description**  
**Voltage Conditioning Circuit**

The circuit shown in Figure 4 shows the signal conditioning circuits for the voltage, current, and temperature channels. All the signals from input/output boards are routed into the analog input channels of ADuCM360 and digitized by the two, on-chip, 24-bit, Σ-Δ integrated ADCs.

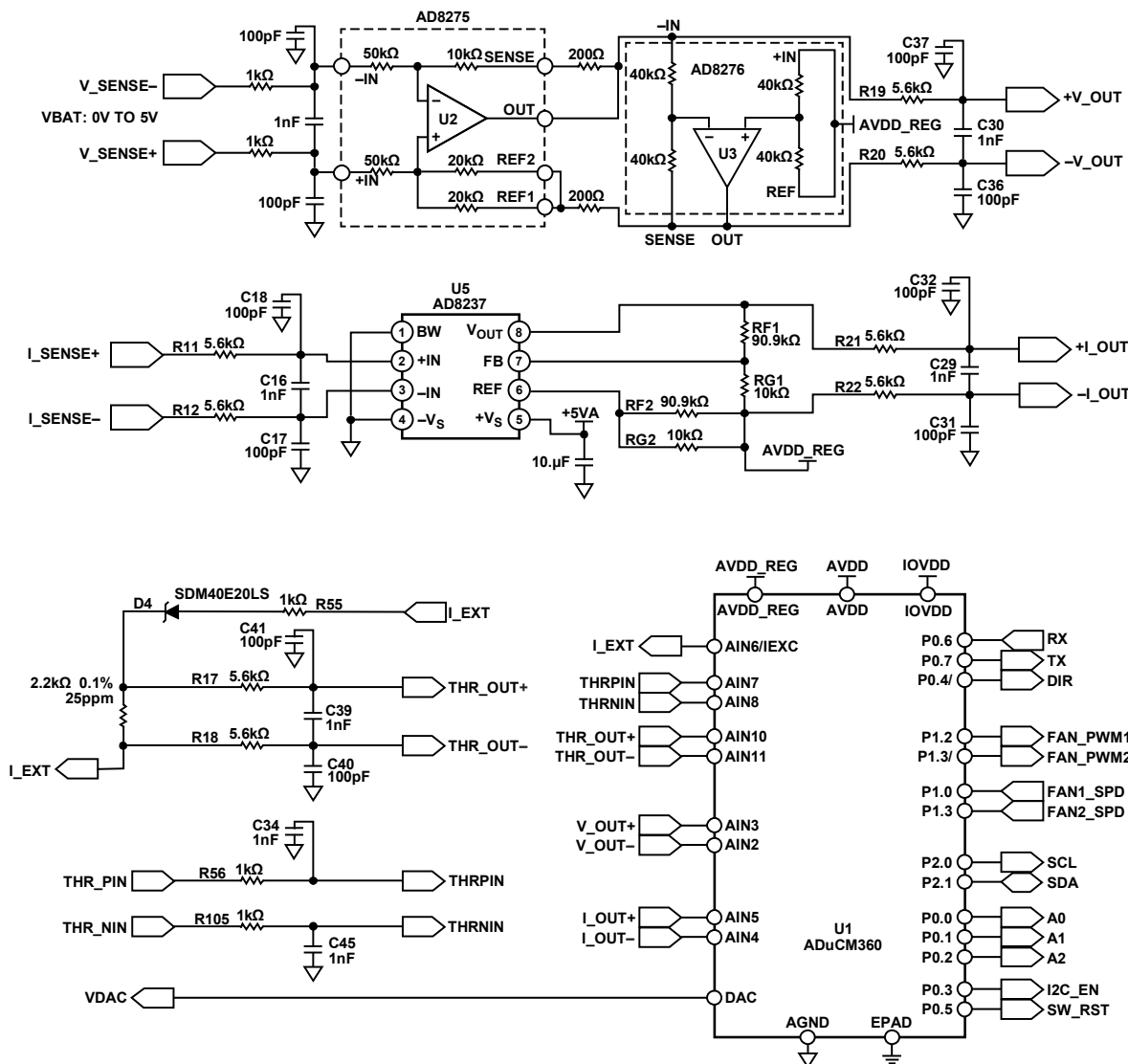

Figure 4. EVAL-CN0352-EB1Z\_MCU, Signal Conditioning, Data Acquisition by ADuCM360 (Simplified Schematic: All Connections and Decoupling Not Shown)

The charging termination voltage is generated by the [ADP5065](#) and is adjustable from 3.5 V to 4.42 V for compatibility with different types of Li-ion batteries. Discharge termination voltage is usually set to 3.0 V. In special circumstances, the battery maybe deeply discharged to a voltage much lower than 3.0 V. The discharge termination voltage can be set from 0 V to 5 V, and that range covers almost conditions for Li-ion battery cells.

The sensed battery voltage is processed by the [AD8275](#) ( $G = 0.2$  difference amplifier) and the [AD8276](#) (unity-gain difference amplifier). The two amplifiers are connected in a balanced circuit to provide a differential output with an overall gain of 0.2 and an output common-mode voltage of 1.8 V.

The two 1 k $\Omega$  resistors placed in series with the [AD8275](#) inputs shown in Figure 4 act as current limiting protection resistors. The 200  $\Omega$  resistors compensate for the reduction in gain due to the 1 k $\Omega$  series resistors and restore the gain of the circuit to 0.2.

With the equations set as shown,

$$\begin{cases} V_{OUT+} - V_{OUT-} = 0.2 \times (V_{SENSE+} - V_{SENSE-}) \\ V_{OUT+} + V_{OUT-} = 2 \times V_{AVDD\_REG} \end{cases}$$

The final voltage of  $V_{OUT+}$  and  $V_{OUT-}$  is

$$\begin{cases} V_{OUT+} = V_{AVDD\_REG} + 0.1 \times (V_{SENSE+} - V_{SENSE-}) \\ V_{OUT-} = V_{AVDD\_REG} - 0.1 \times (V_{SENSE+} - V_{SENSE-}) \end{cases}$$

For a 0 V to 5 V battery voltage range,  $V_{OUT+}$  and  $V_{OUT-}$  vary from 1.8 V to 2.3 V and 2.3 V to 1.8 V, respectively. The differential output voltage ( $V_{OUT+} - V_{OUT-}$ ) is 0 V to 1 V. These ranges are compatible with the common-mode and differential input voltage requirements of [ADuCM360](#).

The configuration of [ADuCM360](#) for voltage acquisition is as follows: differential input on AIN3 and AIN2, unipolar, unity-gain with buffer disabled, and internal reference.

## Current Conditioning Circuit

The battery current is sensed on the input/output boards by a 0.02  $\Omega$  resistor placed in series with the high side of the battery. Assuming that the maximum current during testing is 2 A, the maximum differential voltage across the resistor is  $\pm 40$  mV with the common-mode voltage equal to the battery voltage that can be higher than 4.2 V.

The [AD8237](#) is a micropower, zero drift, rail-to-rail instrumentation amplifier. A simplified block diagram is shown in Figure 5. The [AD8237](#) utilizes the indirect current feedback architecture, and achieves true rail-to-rail capability. The common-mode input voltage can be equal to or slightly beyond the power supply rails.

The gain of the [AD8237](#) circuit is set to 10.09 by the ratio of  $RF1$  to  $RG1$  ( $G = 1 + RF1/RG1$ ). The  $RF2$  and  $RG2$  resistors cancel the error from the input bias current.

The  $\pm 40$  mV current sensed signal is converted to  $\pm 400$  mV with a reference voltage of  $AVDD\_REG = 1.8$  V.

The amplified and level-shifted current sense signal drives the AIN5 and AIN4 differential inputs of the [ADuCM360](#) which is configured for a bipolar input, gain = 2, buffer enabled, and internal reference enabled. The differential voltage at the input of the [ADuCM360](#) internal ADC is  $\pm 800$  mV. The absolute voltage on the input pins are both 1.0 V to 2.6 V.

The current and voltage information is sampled simultaneously using the two internal ADCs in [ADuCM360](#).

Differential and common-mode RFI and noise filters are placed in front of the [AD8275](#), [AD8237](#), and [ADuCM360](#) accordingly.

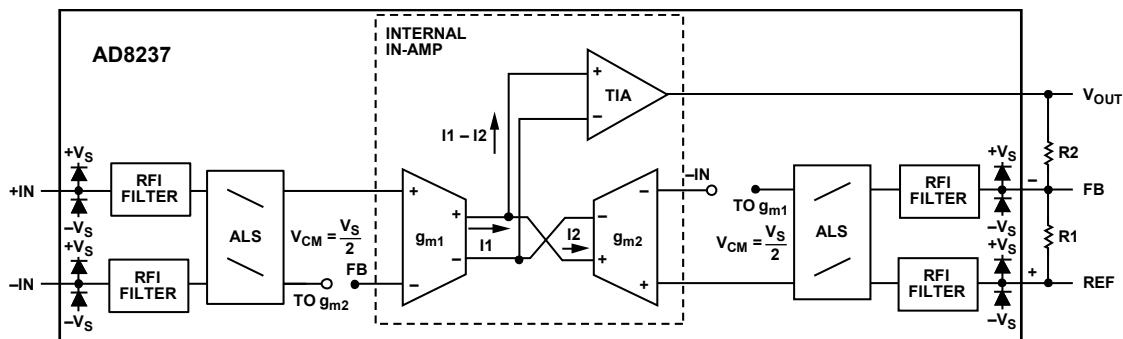

Figure 5. [AD8237](#) Simplified Schematic



**Battery Temperature Conditioning Circuit**

The battery temperature is measured with a 10 kΩ thermistor placed near or inside the battery casing. The value of the thermistor resistor is determined by measuring the voltage across the thermistor when driven with a known current.

As shown in Figure 6, the integrated current source in the ADuCM360 (I\_EXT) drives the 10 kΩ thermistor through a series network that includes a 2.2 kΩ precision current sense resistor, a Schottky diode for reverse voltage protection, two 1 kΩ current limit resistors, and a 10 kΩ bias voltage generator resistor.

The maximum voltage drop through the series connected circuit is

$$V_{MAX} = I_{EXT} \times (1\text{ k}\Omega + 2.2\text{ k}\Omega + 1\text{ k}\Omega + 50\text{ k}\Omega + 10\text{ k}\Omega) + V_F$$

$$= I_{EXT} \times 64.2\text{ k}\Omega + 0.31\text{ V}$$

The total voltage drop must be less than (AVDD – 0.85 V). The exciting current is limited by

$$I_{EXT} \ll (AVDD - 0.85\text{ V} - 0.31\text{ V})/64.2\text{ k}\Omega$$

Therefore, the maximum allowable exciting for this circuit is 33.3 μA. The exciting current is set to 10 μA so that the voltage across the 10 kΩ resistor is less than 0.5 V. The internal ADuCM360 PGA is set for a gain of 2, and the internal buffer of ADuCM360 is enabled.

The bias voltage on the temperature input is 10 μA × 10 kΩ = 0.1 V in order to meet the common-mode input voltage requirement of the ADuCM360 when the internal buffer is enabled.

The excitation current reference channel and thermistor voltage channels are sampled simultaneously to cancel any common-mode error sources, such as drift in the exciting current source or the power supply.

The configuration for temperature acquisition for the reference channel is: differential input, unipolar, gain = 32, buffer enabled, and internal reference.

The configuration for thermistor channel is: differential input, unipolar, gain = 2, buffer enabled, and internal reference.

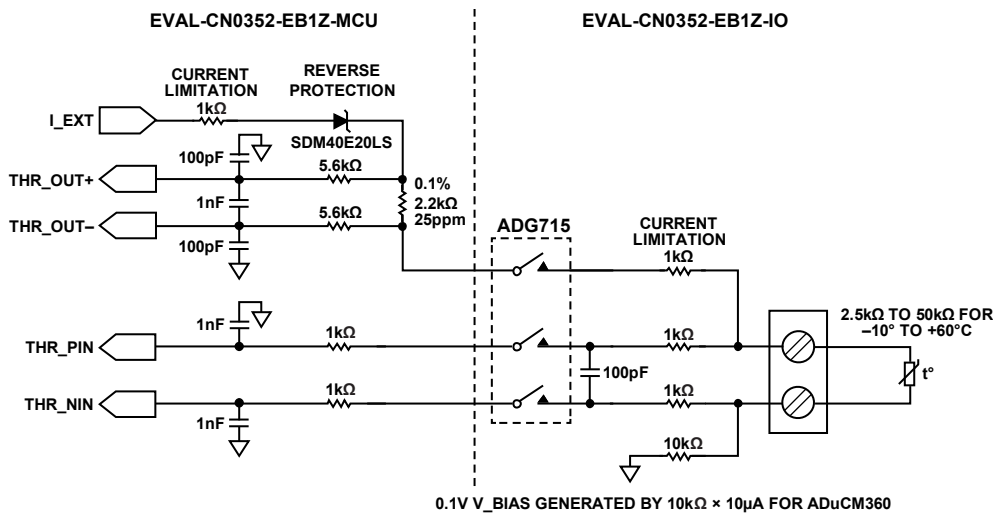

Figure 6. Battery Temperature Conditioning Circuit

12842-006

**Base Board (EVAL-CN0352-EB1Z\_BAS) Description**

**I<sup>2</sup>C Interface Extension**

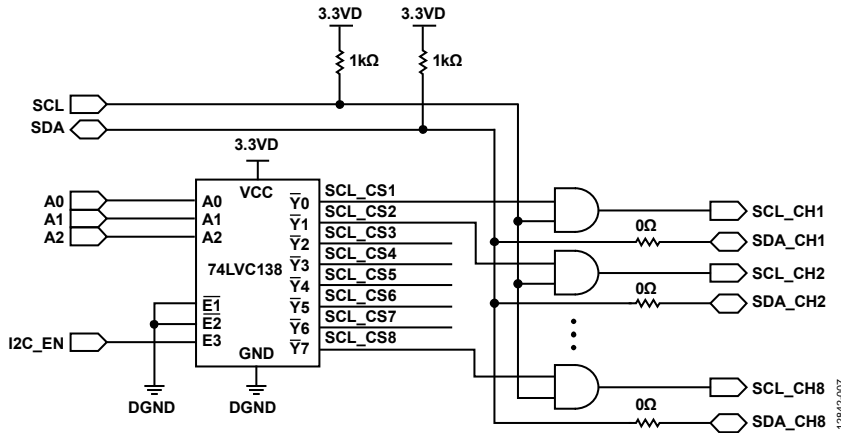

Figure 7. I<sup>2</sup>C interface Extension Circuit

The base board provides the interconnections between the input/output boards and MCU board. The user can address the ADP5065 and the ADG715 on a particular input/output board by using different I<sup>2</sup>C DEV\_ID. The logic shown in Figure 7 uses the 3-bit general-purpose input/outputs (GPIOs) from the ADuCM360 to route the SCLK signal to the proper input/output board. More channels can be added; however, more channels require higher ADC sampling rates, more MCU ram size, faster refreshing rate for the discharging voltage, and higher communication bandwidth to the upper-level processor.

The number of battery channels can be expanded by adding additional EVAL-CN0352-EB1Z systems that share one RS485 bus connection to the PC. In this situation, each module must have a unique ID from 1 to 255. The ID0 is reserved. The CN-0352 evaluation software scans all the IDs and records the ID and channel number for each available ID. Note that the baud rate of RS485 bus is the limiting factor to channel expansion using this approach.

**Circuit Performance Measurements**

System noise was measured by shorting the battery voltage sense pins, V+ and V-, together on the battery connector (shown in Figure 3) and measuring the peak-to-peak variation in the ADC output codes over a 2000 point sampling interval. Similar measurements were done for the current channel. For the temperature channel, a 10 kΩ fixed resistor was connected instead of a thermistor. The results are shown in Figure 8, Figure 9, and Figure 10, respectively.

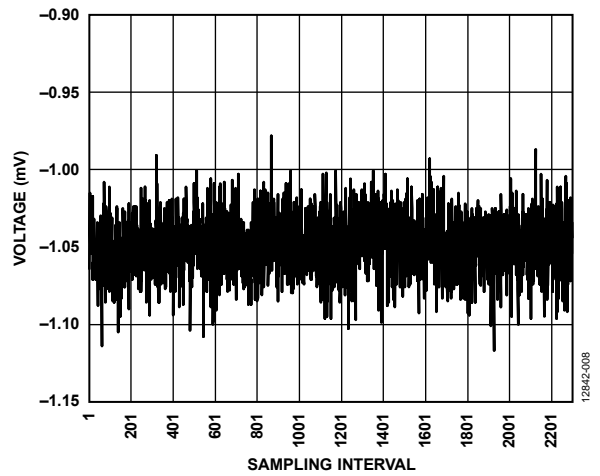

Figure 8. Voltage Noise Measured with Battery Connection Pins Shorted (140 μV p-p Voltage Noise)

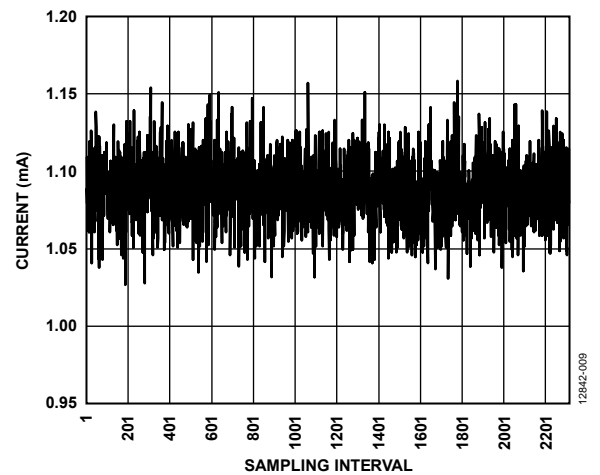

Figure 9. Current Noise Measured with Battery Connections Shorted (140 μA p-p Current Noise)

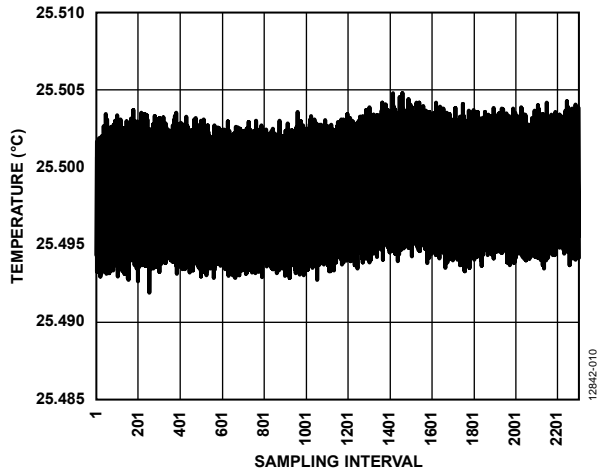

Figure 10. Thermistor Noise Measured with 10 kΩ Resistor (0.014°C p-p Noise)

A typical lithium ion battery charge and discharge profile is shown in Figure 11.

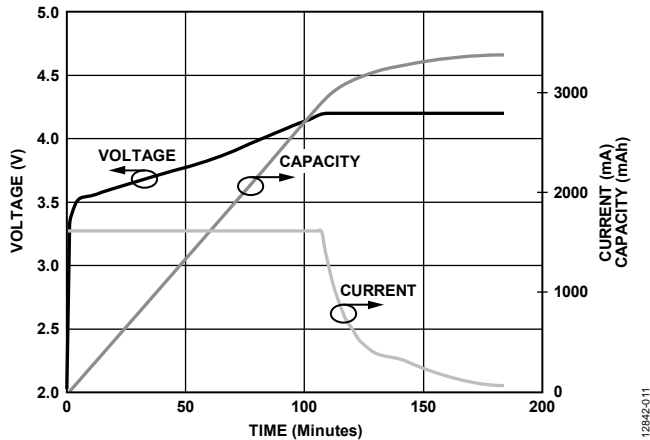

Figure 11. Typical Charging and Discharging Profile

**COMMON VARIATIONS**

The [ADP5061](#) and [ADP5062](#) are both linear battery chargers with management functions for charging current up to 2 A. The [ADP5062](#) is available in a 4 mm × 4 mm LFCSP package.

The [ADG714](#) is an octal, single-pole/single-throw (SPST) switch with a QSPI™-compatible interface. The SPI clock of [ADG714](#) can be much higher than the 400 kHz upper limit of the I<sup>2</sup>C bus. The channel switching time is therefore much shorter than that of the [ADG715](#), and the [ADG714](#) is a better choice for systems with 16 or 32 battery channels.

A complete set of documentation for the EVAL-CN0352-EB1Z board, including complete schematic, MCU source code, layout drawings, Gerber files, and bill of materials are available in the [CN-0352 Design Support Package](#) at [www.analog.com/CN0352-DesignSupport](http://www.analog.com/CN0352-DesignSupport).

**CIRCUIT EVALUATION AND TEST**

**Warning**

This evaluation system interfaces to lithium ion batteries, which can be damaged, catch on fire, or explode if overcharged, over-discharged, or subjected to source or sink currents that exceed the specifications of the battery manufacturer. Take all necessary steps to protect users during operation.

The [CN-0352](#) evaluation software on the PC communicates with the EVAL-CN0352-EB1Z hardware to capture and analyze data from the EVAL-CN0352-EB1Z circuit board.

**Equipment Needed**

The following equipment is needed:

- EVAL-CN0352-EB1Z circuit evaluation board system
- 5 V, 3 A or higher dc power supply or wall wart
- PC or laptop with USB Port
- USB to RS485 adapter supporting baud rate of 115,200 bps
- CN-0352 evaluation software (see the [CN-0352 User Guide](#))
- Li-ion battery samples and battery holder (for safety consideration, using the Li-ion battery with protection circuit integrated is highly recommended)

**Getting Started**

Detailed operation of the evaluation hardware and software is contained in the [CN-0352 User Guide](#), which can be found at [www.analog.com/CN0352-UserGuide](http://www.analog.com/CN0352-UserGuide).

**Functional Diagram**

A functional block diagram of the test setup is shown in Figure 12

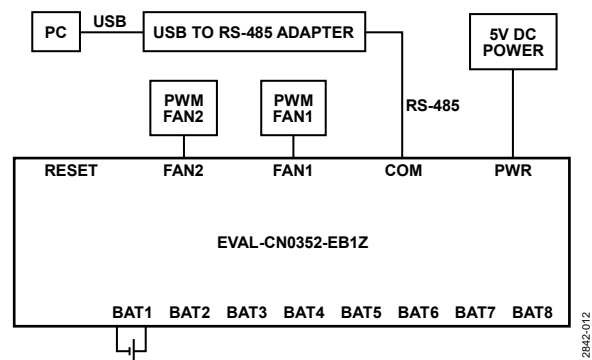

Figure 12. Test Setup Functional Diagram



### Setup

Plug the MCU board (EVAL-CN0352-EB1Z\_MCU) and the input/output boards (EVAL-CN0352-EB1Z\_I/O) into the connector on the base board (EVAL-CN0352-EB1Z\_BAS), as shown in Figure 12. With the 5 V power supply off, connect the 5 V dc power supply to the terminal block marked PWR. The fans for cooling the heat sink on the input/output board are necessary but not included into the packaging box.

The header marked FAN1, FAN2, and FPWR are for connecting to the fans. The pin definitions are shown in Figure 13. Carefully verify the pin connections of the fans. Typical power for a PWM controlled fan is 12 V. The acceptable range of VFAN is 0 V to 15 V. Connect the VFAN to the external dc fan power supply.

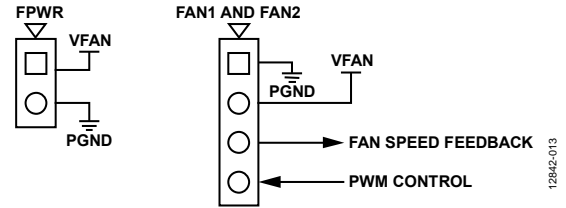

Figure 13. Fan Connections

Plug the USB port of USB to RS485 adapter to the USB port on the PC and connect the RS485 side to the terminal block of the MCU board marked COM.

Turn on the 5 V dc power supply and the fan power supply, then connect the Li-ion battery to the input/output board.

The [CN-0352 Software User Guide](#) provides information and details regarding the test setup and how to use the evaluation software for gathering the test data and analyzing the result.



Figure 14. Complete Battery Testing System Connected to Eight Batteries

**LEARN MORE**

CN-0352 Design Support Package:

[www.analog.com/CN0352-DesignSupport](http://www.analog.com/CN0352-DesignSupport).

“Battery Chargers,” Chapter 5 in *Power and Thermal Management*, Analog Devices, 1998.

MT-031 Tutorial. *Grounding Data Converters and Solving the Mystery of AGND and DGND*. Analog Devices.

MT-101 Tutorial. *Decoupling Techniques*. Analog Devices.

**Data Sheets and Evaluation Boards**

CN-0352 Evaluation System (EVAL-CN0352-EB1Z)

[ADP5065 Data Sheet](#)

[ADG715 Data Sheet](#)

[AD8601 Data Sheet](#)

[AD8237 Data Sheet](#)

[AD8275 Data Sheet](#)

[AD8276 Data Sheet](#)

[ADuCM360 Data Sheet](#)

**REVISION HISTORY**

**3/16—Rev. 0 to Rev. A**

Changes to Circuit Evaluation and Test Section .....8

**1/16—Revision 0: Initial Version**

(Continued from first page) Circuits from the Lab reference designs are intended only for use with Analog Devices products and are the intellectual property of Analog Devices or its licensors. While you may use the Circuits from the Lab reference designs in the design of your product, no other license is granted by implication or otherwise under any patents or other intellectual property by application or use of the Circuits from the Lab reference designs. Information furnished by Analog Devices is believed to be accurate and reliable. However, Circuits from the Lab reference designs are supplied "as is" and without warranties of any kind, express, implied, or statutory including, but not limited to, any implied warranty of merchantability, noninfringement or fitness for a particular purpose and no responsibility is assumed by Analog Devices for their use, nor for any infringements of patents or other rights of third parties that may result from their use. Analog Devices reserves the right to change any Circuits from the Lab reference designs at any time without notice but is under no obligation to do so.

©2016 Analog Devices, Inc. All rights reserved. Trademarks and registered trademarks are the property of their respective owners.  
CN12842-0-3/16(A)

