

CLARKE® **WOODWORKER**



10" TABLE SAW WITH EXTENDABLE TABLE
MODEL NO: CTS14

PART NO: 6500745

**OPERATION & MAINTENANCE
INSTRUCTIONS**



LS0314

INTRODUCTION

Thank you for purchasing this CLARKE product. The table saw has been designed to perform the sawing operation of ripping, cross-cutting, bevelling and mitring wood and wood products. This unit is designed for use with a 250 mm carbide tipped blade.

Before attempting to use this product, please read this manual thoroughly and follow the instructions carefully. In doing so you will ensure the safety of yourself and that of others around you, and you can look forward to your purchase giving you long and satisfactory service.

GUARANTEE

This product is guaranteed against faulty manufacture for a period of 12 months from the date of purchase. Please keep your receipt which will be required as proof of purchase.

This guarantee is invalid if the product is found to have been abused or tampered with in any way, or not used for the purpose for which it was intended.

Faulty goods should be returned to their place of purchase, no product can be returned to us without prior permission.

This guarantee does not effect your statutory rights.

ENVIRONMENTAL RECYCLING POLICY



Through purchase of this product, the customer is taking on the obligation to deal with the WEEE in accordance with the WEEE regulations in relation to the treatment, recycling & recovery and environmentally sound disposal of the WEEE.

In effect, this means that this product must not be disposed of with general household waste. It must be disposed of according to the laws governing Waste Electrical and Electronic Equipment (WEEE) at a recognised disposal facility.

CONTENTS

The following items should be supplied in the carton. If any parts are missing, do not operate your table saw until the missing parts are obtained.

1 x Table Saw	1 x Fixings Pack
1 x R/H Extension Table Assembly	1 x Push Stick
1 x Parallel Guide Fence	1 x 250 mm TCT Blade (fitted)
1 x Parallel Guide Fence Mount & Clamp Assembly	1 x Upper Blade Guard Assembly c/w Fixings
1 x Mitre Guide Assembly	1 x 6 mm Hex Key
1 x Flange Key	1 x Extraction Hose Assembly

SAFETY SYMBOLS

	Read this instruction booklet carefully before positioning, operating or adjusting the table saw.
	Wear eye protection
	Wear ear protection
	Wear a dust mask that is specially designed to filter microscopic particles.

SAFETY WARNINGS



CAUTION: DO NOT LET FAMILIARITY WITH YOUR TABLE SAW MAKE YOU CARELESS. REMEMBER THAT A CARELESS FRACTION OF A SECOND IS SUFFICIENT TO CAUSE SEVERE INJURY.

PERMITTED USAGE

The table saw is constructed exclusively for the sawing of wood. The appropriate saw blade should be fitted according to the cut type and the wood type (solid wood, chipboard or plywood).

- Read and understand the entire owner's manual before attempting assembly or operation.
- Read and understand the warnings posted on the machine and in this manual. Failure to comply with all of these warnings may cause serious injury.

HEALTH

When drilling, sanding, sawing or grinding, dust particles will be produced. In some instances this dust can be harmful (e.g. lead from old gloss paint, arsenic and chromium from chemically treated lumber).

To reduce the risk you should:

- Work in a well-ventilated area.
- Work with approved safety equipment, such as dust masks that are specially designed to filter microscopic particles.

GENERAL

1. Do not expose the tool to rain.
2. Do not use the tool in damp or wet conditions.

3. Keep the work area well lit.
4. Do not use the tool in the presence of flammable liquids and gases.
5. Remove loose items and unnecessary work pieces from the area before starting the machine.
6. Clean out sawdust from the interior of the saw to prevent a potential fire hazard, attach a vacuum cleaner to the dust port for additional sawdust removal.
7. Wear ear protectors (plugs or muffs) during extended periods of operation.
8. Wear safety glasses. Everyday eyeglasses are not suitable as safety glasses.
9. Wear a dust mask when sawing wood.
10. Never wear gloves during operation.
11. Before operating this table saw, remove neck tie, rings, watches and other jewellery, and roll sleeves up past the elbows. Remove all loose clothing and confine long hair. Non-slip footwear or anti-skid floor strips are recommended.
12. Make sure that the machine stands stable on firm ground.

13. Before use, carefully check the tool and mains cable for damage or any other condition that may affect its operation. Do not use the tool if any part is damaged or defective.
14. Do not use the tool if the switch does not turn it on and off.
15. Remove adjusting keys and wrenches. Form the habit of checking to see that keys and adjusting wrenches are removed from the tool before turning it on.
16. Use the right tool - Do not force small tools to do the job of a heavy duty tool. It will do the job better and safer at the rate for which it was intended. Do not use tools for purposes not intended; for example do not use table saws to cut tree limbs or logs.
17. Do not overreach - Keep proper footing and balance at all times.
18. Connect table saws to a dust-collecting device when sawing wood.
19. The use of any accessory or attachment other than one recommended in this instruction manual may present a risk of personal injury.
20. Guard against electric shock - Avoid body contact with earthed or grounded surfaces (e.g. pipes, radiators, ranges, refrigerators).
21. Extension cables - Before use, inspect the extension cable and replace if damaged. When using the tool outdoors, only use extension cables intended for outdoor use and marked accordingly.
22. Avoid unintentional starting. Make sure the switch is in the OFF position before connecting the machine to the power supply.
23. Don't abuse the cable. Never yank the cable to disconnect it from the mains supply. Keep the cable away from heat, oil, water and sharp edges.
24. This table saw is designed and intended for use by properly trained and experienced personnel only. If you are not familiar with the proper and safe operation of a table saw, do not use until proper training and knowledge have been obtained.
25. Stay alert, watch what you are doing. Use common sense. Do not operate the tool when you are tired.
26. Do not operate this machine while tired or under the influence of drugs, alcohol or any medication.
27. Keep hands out of the line of saw blade.
28. Maintain a balanced stance at all times so that you do not fall on to the blade or other moving parts. Do not overreach or use excessive force to perform any machine operation.
29. Use push-sticks or push blocks to feed the workpiece past the saw blade. Keep your hands and fingers well away from the blade.
30. The push-stick should always be stored with the machine when not in use.
31. Pay particular attention to instructions on reducing risk of kickback.

32. NEVER perform any operation freehand, which means using only your hands to support or guide the workpiece. Always use either the fence or the mitre gauge to position and guide the work.



WARNING: FREEHAND CUTTING IS THE MAJOR CAUSE OF KICKBACK AND FINGER/HAND AMPUTATIONS.

33. Give your work undivided attention. Looking around, carrying on a conversation and “horse-play” are careless acts that can result in serious injury.
34. Replace the warning labels if they become obscured or removed.
35. When not in use, tools must be stored in a dry place and locked up securely, out of reach of children.
36. Turn off and unplug the machine before cleaning. Use a brush or compressed air to remove chips or debris — do not use your hands.
37. Disconnect the saw from the mains supply before changing blades or carrying out maintenance.
38. Keep cutting tools sharp and clean for better and safer performance. Inspect power cords periodically and if damaged have them repaired.
39. Repairs should only be carried out by qualified persons using original spare parts, otherwise this may result in considerable danger to the user.
40. Keep handles dry, clean and free from oil and grease.

41. Unplug the tool - Switch off and wait for the blade to come to a complete standstill before leaving it unattended.

42. Never use solvents to clean plastic parts. Solvents could possibly dissolve or otherwise damage the material. A soft damp cloth should be used to clean plastic parts.

ADDITIONAL SAFETY RULES FOR TABLE SAWS

- The thickness of the saw blade must be greater than the thickness of the riving knife.
- Do not stand on top of the unit.
- During transportation make sure that the upper part of the saw blade is covered, e.g. by the guard.
- Do not use the guard for handling or transportation.
- Check that the workpiece is properly supported. Always provide additional support for long workpieces.
- Do not exert side pressure on the saw blade.
- Make sure that the blade rotates in the correct direction and that the teeth are pointing to the front of the table saw.
- Do not attempt to operate on anything but the designated voltage.
- Do not apply lubricants to the blade when it is running.

- NEVER reach around or over the saw blade. NEVER reach for a workpiece until the saw blade has completely stopped.
- Make sure that the blade and flanges are clean and the recessed sides of the collar are against the blade. Tighten the arbor nut securely.
- Keep the saw blade sharp and properly set.
- Make sure that the riving knife is adjusted to the correct distance from the blade.
- Never operate the saw without the guards in place.
- Do not use abrasive discs or diamond cutting wheels.
- Rebating, slotting or grooving is not allowed.
- Do not use a moulding head cutter with this saw.
- Remove the rip fence when crosscutting. Never use the rip fence as a cut-off gauge when crosscutting.
- Knock out any loose knots from the workpiece before you begin to cut.
- Provide adequate support to the rear and the sides of the saw table for long or wide workpieces.
- Never leave the machine running unattended. Turn the power off and do not leave the machine until it comes to a complete stop.
- Before using the tool on an actual workpiece, let it run for a while. Watch for vibration or wobbling that could indicate poor installation or a poorly balanced blade.
- Always hold work firmly against the mitre gauge or rip fence.
- NEVER stand or have any part of your body in line with the path of the saw blade. Keep your hands out of the saw blade path.
- Feed work into the blade against the direction of rotation only.
- NEVER attempt to free a stalled saw blade without first turning the saw off. Turn the power switch off immediately to prevent motor damage.
- Avoid awkward operations and hand positions where a sudden slip could cause your hand to move into the saw blade.
- Avoid abrupt, fast feeding. Feed as slowly as possible when cutting hard workpieces. Do not bend or twist the workpiece while feeding. If you stall or jam the blade in the workpiece, turn the table saw off immediately. Unplug the table saw. Then clear the jam.
- NEVER remove cut-off pieces near the blade or touch the blade guard while the blade is running.

SAW BLADES

1. The maximum speed of the saw blade must always be equal to or greater than the no-load speed of the table saw as specified on the rating plate.
2. Do not use saw blades which are damaged or deformed.

3. Only use saw blades recommended by the manufacturer and which are the exact bore and diameter required for this machine. Do not use any spacers to make a blade fit onto the spindle. Use only the blades specified in this manual, which comply with EN 847-1.
4. Clean the spindle, flanges (especially the installing surface) and hex nut before installing the blade. Poor installation may cause vibration/wobbling or slippage of the blade.
5. Take care that the selection of the saw blade is suitable for the material to be cut.
6. Make sure the blade is not contacting the riving knife or workpiece before the switch is turned on.
7. Wear gloves when handling saw blades and rough material. Saw blades shall be carried in a holder whenever practicable.

KICKBACK

Kickback is a sudden reaction to a pinched, bound or misaligned saw blade, it causes the workpiece to be ejected from the tool back towards the operator. Kickbacks can lead to serious personal injury.

You can avoid kickbacks by:

- a. keeping the blade sharp,
- b. keeping the rip fence parallel to the blade,
- c. keeping the riving knife and blade guard in place and operating properly,
- d. by not releasing the workpiece until you have pushed it all the way past the blade,
- e. not ripping a workpiece that is twisted or warped or does not have a straight edge to guide along the fence.

If you do not have a clear understanding of kickback and how it occurs, DO NOT operate this table saw!

REMAINING HAZARDS

The machine has been built in accordance with recognized safety rules. Some remaining hazards may still exist.

- The rotating saw blade can cause injuries to fingers and hands if the work piece is incorrectly fed.
- Thrown work pieces can lead to injury if the work piece is not properly secured or fed, such as working without a limit stop.
- Noise can be a health hazard. The permitted noise level is exceeded when working. Be sure to wear personal protective equipment such as ear protection.
- Defective saw blades can cause injuries. Regularly inspect the structural integrity of saw blades.
- The use of incorrect or damaged mains cables can lead to injuries caused by electricity.
- Remaining hazards can be minimized by following the instructions in the operating manual.

ELECTRICAL CONNECTIONS



WARNING: READ THESE ELECTRICAL SAFETY INSTRUCTIONS THOROUGHLY BEFORE CONNECTING THE PRODUCT TO THE MAINS SUPPLY.

Before switching the product on, make sure that the voltage of your electricity supply is the same as that indicated on the rating plate. Connecting it to any other power source may cause damage.

If it is necessary to change the fuse in the plug, the fuse cover must be refitted. If the fuse cover becomes lost or damaged, the plug must not be used until a suitable replacement is obtained.

If the plug has to be changed due to damage, a replacement should be fitted, following the wiring instructions shown below. The old plug must be disposed of as insertion into a mains socket could cause an electrical hazard.



**WARNING: THE WIRES IN THE POWER CABLE OF THIS PRODUCT ARE COLOURED IN ACCORDANCE WITH THE FOLLOWING CODE:
BLUE = NEUTRAL BROWN = LIVE**

If the colours of the wires in the power cable of this product do not correspond with the markings on the terminals of your plug, proceed as follows.

- The wire which is coloured **Blue** must be connected to the terminal which is marked **N** or coloured **Black**.
- The wire which is coloured **Brown** must be connected to the terminal which is marked **L** or coloured **Red**.

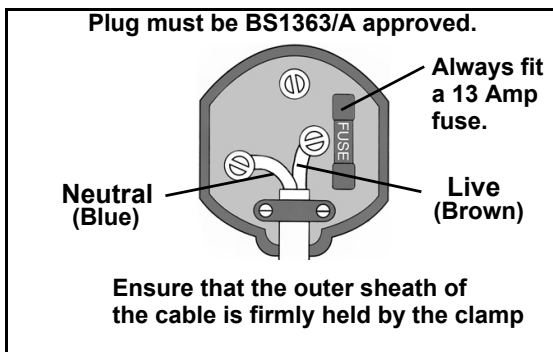

We strongly recommend that this machine is connected to the mains supply via a Residual Current Device (RCD)

If in any doubt, consult a qualified electrician. DO NOT attempt any repairs yourself.



This symbol indicates that this is a Class II product, and does not require an earth connection.

PART IDENTIFICATION

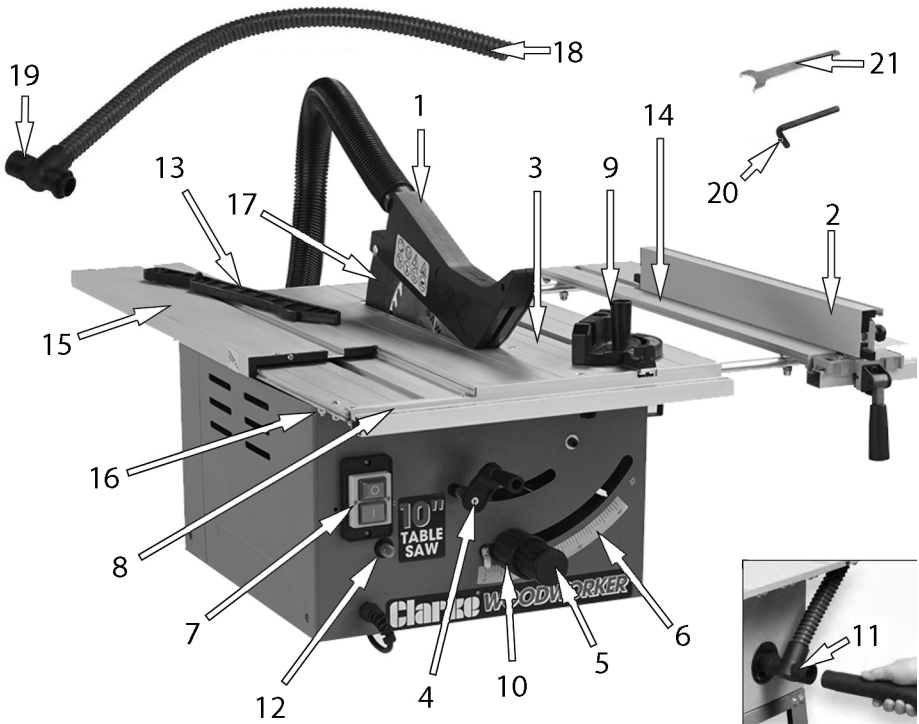

1	Blade Guard	12	Overload Protection Indicator
2	Parallel Fence	13	Push Stick
3	Table Insert	14	Right Side Extension Table
4	Blade Height Adjusting Handle	15	Left Hand Sliding Table
5	Bevel Lock	16	Left Side Table Lock
6	Blade Angle Scale	17	Riving Knife
7	On/Off Switch	18	Extractor Hose
8	Scale For Parallel Fence	19	Hose Adaptor
9	Mitre Fence	20	Hexagonal Key
10	Blade Angle Adjustment Handle	21	Blade Flange Key
11	Dust Extraction Connection Socket		

ASSEMBLY

- Unpack and check for damage which may have occurred in transit.
- Place the saw on a flat and firm surface.

FIT THE RIGHT EXTENSION TABLE

1. Remove the screws from the end of the slide bars.

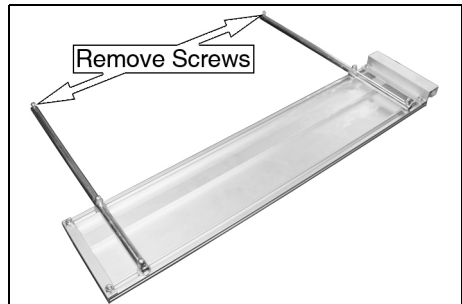

2. Push the slide bars into the holes under the table.

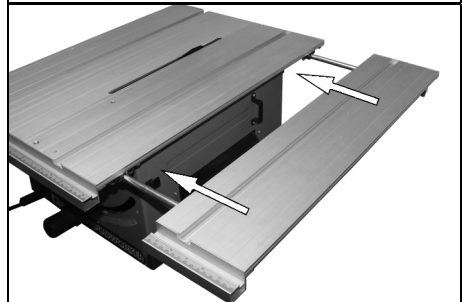

3. Replace the screws on the end of the slide bars.

- Adjust the right extension table as required then tighten the extension locking screw under the table to lock the right extension table in place.

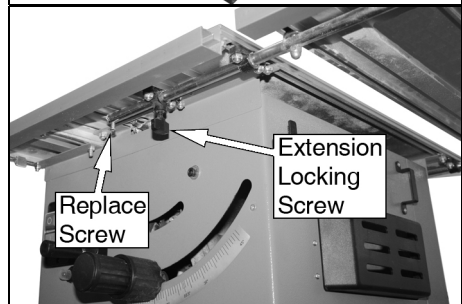

ADJUST THE LEFT HAND SLIDING TABLE

1. The left hand sliding table can slide back and forth by pushing the table release inwards to release and adjusting the table as required.

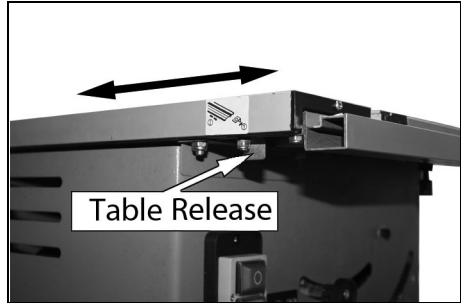

FITTING THE BLADE GUARD



WARNING: REMOVE THE PLUG FROM THE MAINS SUPPLY BEFORE CARRYING OUT ANY ADJUSTMENT, SERVICING OR MAINTENANCE

1. Mount the blade guard on the riving knife as shown.
2. Use the securing bolt to secure the blade guard.
 - Do not tighten the blade guard securing handle too far - the blade guard must be able to rise and fall freely.
3. To remove the saw blade guard, proceed in reverse order.

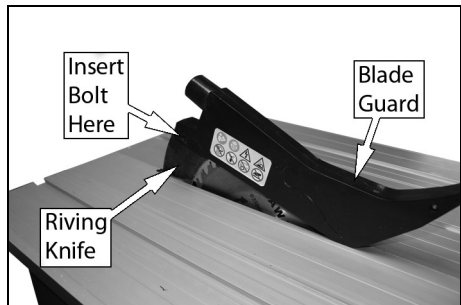

The guard must always be lowered over the workpiece before you begin to cut.

DUST EXTRACTION

Always use an extracting device or vacuum cleaner, or ensure that the workplace is well ventilated.

The machine is fitted with a connecting socket for a 30mm diameter extractor hose.

1. Insert the hose adapter with the grooved end into the connection port and lock in place by turning slightly to the right.
2. Fit the other end to the blade guard.

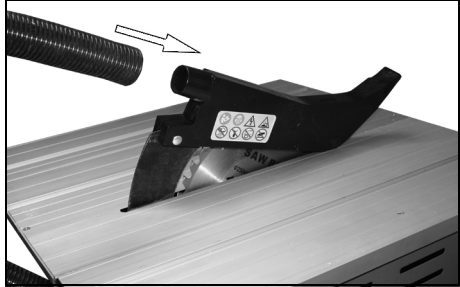
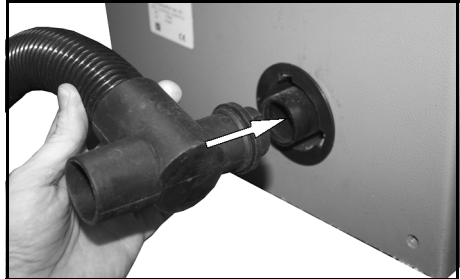

CHANGING THE BLADE



WARNING: REMOVE THE PLUG FROM THE MAINS SUPPLY BEFORE CARRYING OUT ANY ADJUSTMENT, SERVICING OR MAINTENANCE

1. Remove the table insert by undoing the countersunk screws.
2. Undo the blade retaining nut using the flange key and hexagonal key together.

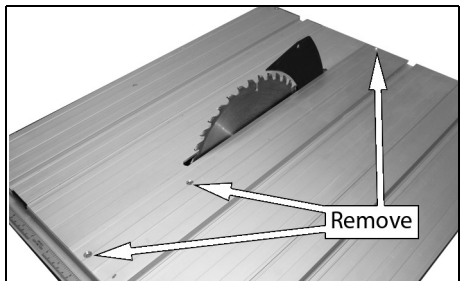

3. Take off the outer flange and remove the old saw blade.
 - Replacement blades are available from our parts department (part number NHECTS14115).
4. Clean the blade flanges thoroughly before fitting the new blade.
5. Mount and fasten the new blade in reverse order.

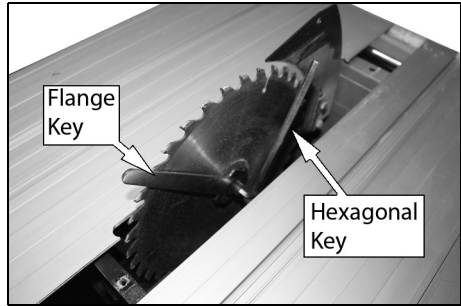

IMPORTANT: Note the running direction. The cutting angle of the teeth must point in the running direction, i.e. forwards (see the arrow on the blade guard).

6. Loosen the bolts that hold the riving knife and adjust the riving knife position until the distance between the blade and the riving knife is between 3-5 mm.

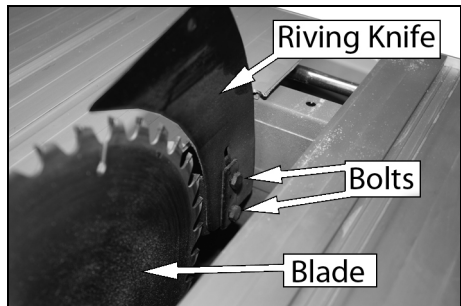

7. Retighten the bolts.
8. Replace the table insert.
9. Replace the saw blade guard.
10. Check to make sure that all components are properly mounted and in good working condition before you begin working with the saw again.

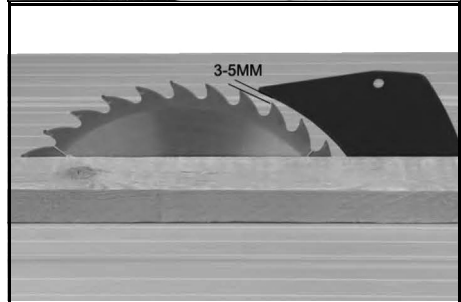

WARNING: RESET THE RIVING KNIFE EACH TIME THE SAW BLADE IS REPLACED.

BEFORE STARTING WORK

- All covers and safety devices have to be properly fitted before the machine is switched on.
- When working with wood that has been used before, remove all foreign bodies such as nails or screws etc before cutting.
- Before you switch on, make sure that the saw blade is correctly fitted and that the machine's moving parts run smoothly.
- Before you connect the machine to the power supply, make sure the data on the rating plate is the same as that for your mains supply.

ADJUSTMENTS

After every new adjustment, we recommend you to make a trial cut in order to check the new settings.

PARALLEL FENCE

CUTTING WIDTH

The parallel fence can be mounted on either side of the saw table. If you change the side, you will need to move the parallel fence to the other side of the holder.

1. Slide the parallel fence into the guide rail of the saw table.
2. Use the scale on the guide rail to set the parallel fence to the required distance from the blade.
3. Lock the parallel fence in the required position by pressing down on the lever.

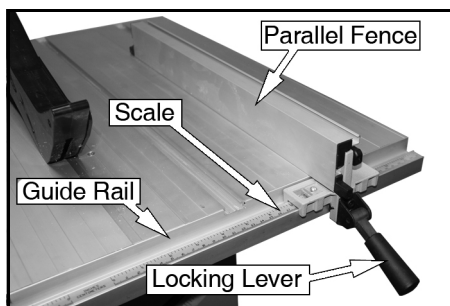

MITRE GAUGE

1. Insert the guide bar into one end of the groove on the table.
2. Loosen the handle by twisting it counterclockwise.
3. Rotate the gauge until the arrow points to the angle on the scale you want.
4. Retighten the handle.

NOTE: If required you can remove the fence from the parallel fence assembly and attach it to the mitre gauge using the 2 locking knobs from the parallel fence.

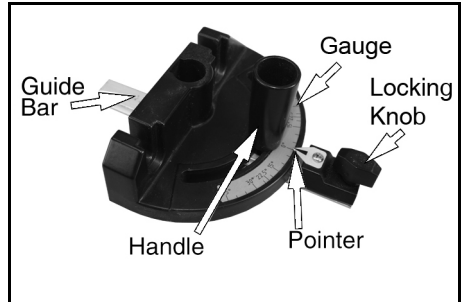

SETTING BLADE HEIGHT

Turn the blade height adjusting handle to set the blade to the required height.

- Anti-clockwise to raise the blade.
- Clockwise to lower the blade.



SETTING THE BLADE ANGLE

1. Release the bevel lock
2. Turn the bevel adjustment until the saw blade is at the desired angle.
3. Tighten the bevel lock to lock the blade at the required angle shown on the scale.

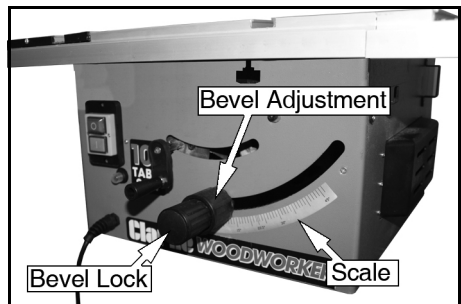

OPERATION



CAUTION: BEFORE STARTING UP THE SAW ALWAYS CHECK THE FOLLOWING POINTS:

1. Is the saw blade firmly tightened?
2. Are all the locking levers firmly locked?
3. Is the riving knife aligned with the saw blade?
4. Is the saw blade guard fitted?
5. Make sure that the fences are not touching the saw blade.
6. Can the saw blade rotate freely?
7. Are there any wood pieces jammed between the saw blade and the table insert?
8. Have all loose workpieces been removed from the table saw?
9. Have all the setting tools been removed?
10. Wear protective goggles, ear protection and dust mask.

ON/OFF SWITCH

1. To turn the saw on, press the green button "I".
 - Wait for the blade to reach its maximum speed before commencing with the cut.
2. To turn the machine off again, press the red button "O".

NOTE: The blade will spin for several seconds after the machine is switched off.

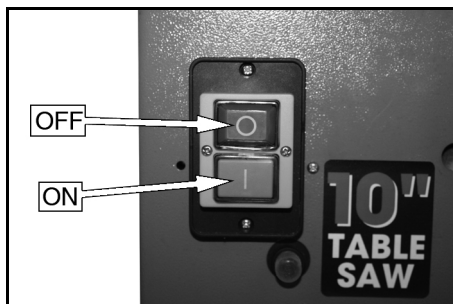

MOTOR BRAKE

The motor is fitted with a brake which should stop the saw blade in under 10 seconds.

If this time is exceeded, the brake must be repaired by an authorised service centre.

A saw with a defective brake must not be used.

OVERLOAD RESET BUTTON

This table saw has a thermal overload protection device.

If the saw gets too hot, the thermal overload device cuts the power which prevents damage to the motor.

If the thermal overload device operates, let the motor cool down for 5 minutes and push the reset button located just below the ON (I) button

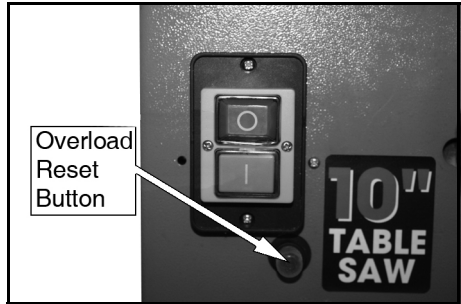

If you start the saw and the overload cutout operates again, disconnect from the power supply and have your table saw examined by a qualified service agent.

CUTTING TIPS

RIPPING CUTS

Ripping is when you use the saw to cut along the grain of the wood.

The parallel fence must always be used when making ripping cuts.

1. Press one edge of the workpiece against the parallel fence while the flat side lies on the saw table.
 - The blade guard must always be lowered over the workpiece and blade.
 - When you make a ripping cut, never stand in line with the blade.
2. Set the parallel fence in accordance with the workpiece height and the desired width.
3. Switch on the saw.
4. Place your hands (with fingers closed) flat on the workpiece and push the workpiece along the parallel fence towards the blade.
5. Guide at the side with your left or right hand (depending on the position of the parallel fence) only as far as the front edge of the guard hood.



6. Always push the workpiece through to the end of the riving knife using a push stick.
7. Do not remove the offcut piece until the blade has stopped spinning.
8. Secure long workpieces against falling off at the end of the cut (e.g. with a roller stand etc.).

CUTTING NARROW WORKPIECES

Always use a push stick when the workpiece is smaller than 120 mm in width.



When not in use, place the push stick in its storage clip on the side of the saw.

Replace a worn or damaged push stick immediately.

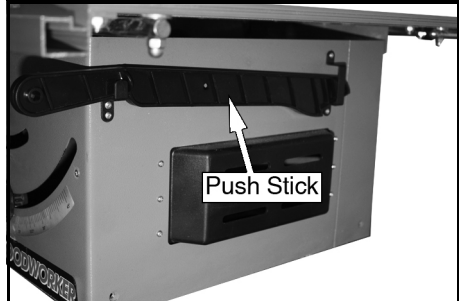

BEVEL CUTS

Bevel cuts must always be made using the parallel fence.

1. Undo the bevel lock.
2. Turn the bevel adjustment to set the desired angle on the scale.
3. Tighten the bevel lock to lock the blade at the selected angle.
4. Set the parallel fence.
5. Perform the cut as you would for a ripping cut.

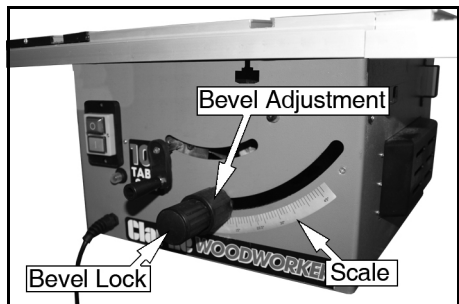

CROSS CUTS

1. Slide the mitre gauge into one of the grooves in the table.
2. Adjust the mitre gauge to the required angle.
3. Press the workpiece firmly against the mitre gauge.
4. Switch on the saw.
5. Push the mitre gauge and the workpiece toward the blade to make the cut.

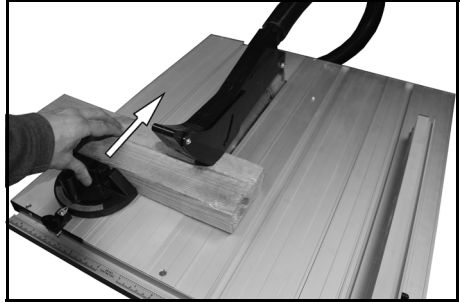

IMPORTANT: Always hold the guided part of the workpiece. Never hold the part which is to be cut off.

6. Push the mitre gauge forward until the workpiece is cut all the way through.
7. Switch off the saw. Do not remove the offcut until the blade has stopped rotating.

MAINTENANCE



WARNING: REMOVE THE PLUG FROM THE MAINS POWER SUPPLY BEFORE CARRYING OUT ANY ADJUSTMENT. SERVICING OR MAINTENANCE

- Remove dust and dirt regularly from the machine. Cleaning is best carried out with a fine brush or a cloth.
- Never use caustic agents to clean plastic parts.
- Keep the saw unit clean.

CLEANING THE THREADED RODS

This operation should be carried out at least once a year

1. Place the machine on its side.
2. Remove the base plate by undoing the screws.
3. Clean the threaded rods and lubricate them with a multi-purpose grease.

REPLACING THE CARBON BRUSHES (ITEM 127 IN THE PARTS LIST)

Check the carbon brushes every 10 operating hours. If the length of the carbon brushes is less than 5 mm, you should change them to prevent damage to the motor.

1. Move the saw blade to its lowest position.
2. Place the machine on its side.
3. Remove the base plate.
4. Unscrew the carbon brush covers.
5. Inspect the carbon brushes and, if necessary replace them.
6. Replace the base plate.
 - Allow the machine to run for a few minutes to allow the carbon brushes to run in.



CAUTION: CARBON BRUSHES MUST BE REPLACED IN PAIRS

SPECIFICATIONS

Voltage	230V - 50 Hz
Power input	1800 W
No-load speed	4700 rpm
Overload protection	Yes
Table size with extension:	660 mm x 690 mm
Extractor socket	36 mm (external)
Blade size:	Outside Diameter 250 mm
	Bore Diameter 30 mm
	Thickness 2.8 mm
Maximum cut depth @ 90 Degrees	72 mm
Maximum cut depth @ 45 Degrees	65 mm
Machine weight:	17.35 kg
Sound pressure level LpA	94.8 dB (A)
Sound power level LWA:	107.8 dB (A)

Please note that the details and specifications contained herein, are correct at the time of going to print. We reserve the right to change specifications at any time without prior notice.

EXPLODED DIAGRAM

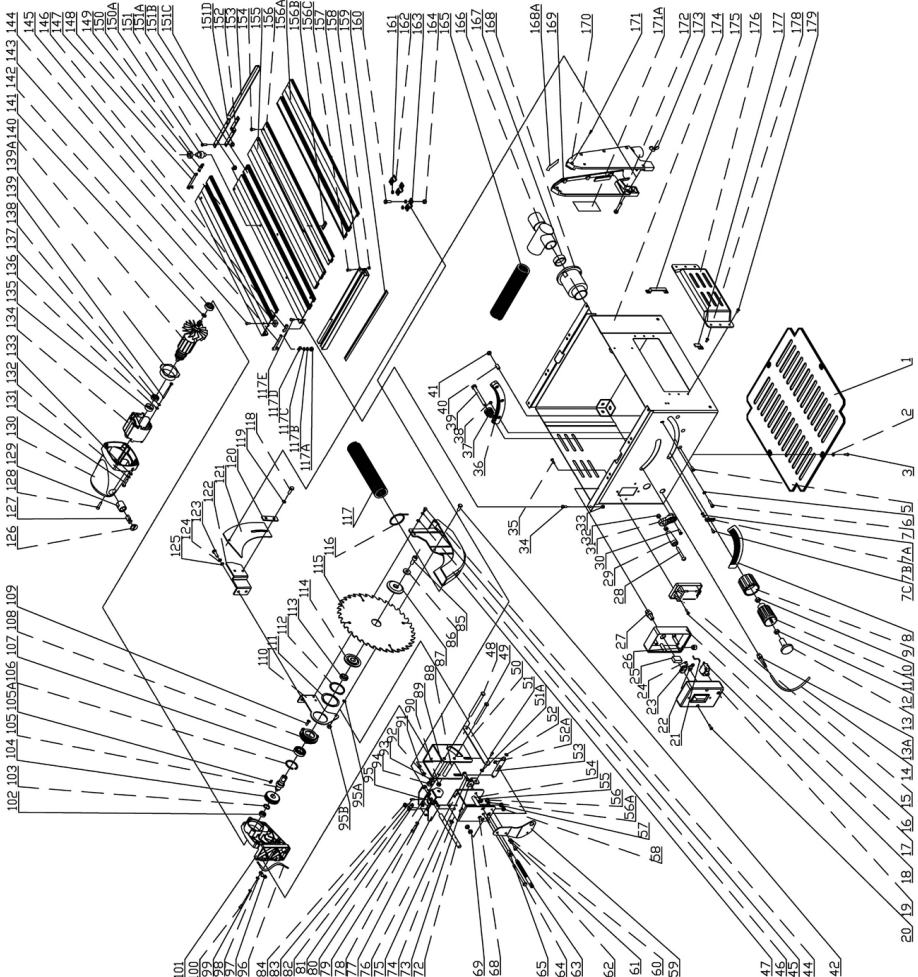
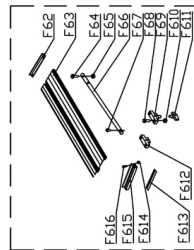
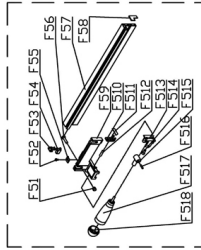
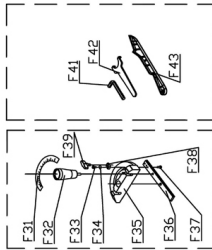
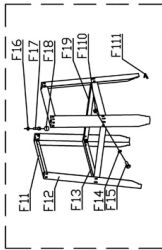

No	Part Name	
001	Box Bottom Cover	NHECTS14001
002	Washer	NHECTS14002
003	Screw M4x10	NHECTS14003
004	Screw M4x14	NHECTS14004
006	Washer?18?1.2?6.5?	NHECTS14006
007	Screw M6x25	NHECTS14007
007a	Washer	NHECTS14007A
7b	Angle Pointer	NHECTS14007B
7c	Screw M4x10	NHECTS14007C
8	Angle Scale	NHECTS14008
9	Angle Adjust Handle	NHECTS14009
10	Lock Nut M8	NHECTS14010
11	Angle Lock Handle	NHECTS14011
12	Nut M8(13)	NHECTS14012
13	Handle Cover	NHECTS14013
13a	Cable Locker	NHECTS14013A
14	Cable	NHECTS14014
15	Switch	NHECTS14015
16	Screw St 4x40	NHECTS14016
17	Switch Base	NHECTS14017
18	Over-load Protector	NHECTS14018
19	Switch Base Cover	NHECTS14019
20	Screw St4x16	NHECTS14020
21	Wire	NHECTS14021
22	Cable Press Board	NHECTS14022
23	Wire Connection	NHECTS14023
24	Screw St4x16	NHECTS14024
25	Capacitor	NHECTS14025
26	Cable Bush	NHECTS14026
27	Cable Locker	NHECTS14027
28	Screw M6x45	NHECTS14028
29	Rocker Handle	NHECTS14029
30	Screw M5x16	NHECTS14030
31	Rocker	NHECTS14031
32	Nut M6	NHECTS14032
33	Nut M6	NHECTS14033
34	Bolt M6	NHECTS14034
35	Screw St4x14	NHECTS14035
36	Tooth Orbit	NHECTS14036
37	Gear	NHECTS14037
38	Nut M4	NHECTS14038
39	Bolt M8x75	NHECTS14039
40	45 Lock Pole	NHECTS14040

No	Part Name	
41	Nut 6	NHECTS14041
42	Bolt M6x16	NHECTS14042
44	Screw M5x10	NHECTS14044
45	Spring Washer 5	NHECTS14045
46	Flat Washer 5	NHECTS14046
47	Inner Guard	NHECTS14047
48	Support Board A Bolt	NHECTS14048
49	Bolt M6x80	NHECTS14049
50	Connection Bar	NHECTS14050
51	Lock Pin	NHECTS14051
51a	Spring Washer 8	NHECTS14051A
52	Flat Washer 8	NHECTS14052
52a	Flat Washer 10	NHECTS14052A
53	Bolt	NHECTS14053
54	Lock Pole 1	NHECTS14054
55	Nut M6	NHECTS14055
56	Nut M6	NHECTS14056
56a	Flat Washer 6	NHECTS14056A
57	Lock Nut M6	NHECTS14057
58	Nut M6	NHECTS14058
59	Turn Board	NHECTS14059
60	Flat Washer 5	NHECTS14060
61	Spring Washer 5	NHECTS14061
62	Screw M5x10	NHECTS14062
63	Adjust Bolt	NHECTS14063
64	Bolt M6x80	NHECTS14064
65	Bolt M6x16	NHECTS14065
68	Support Board B	NHECTS14068
69	Nut M10	NHECTS14069
72	Return Shaft	NHECTS14072
73	Lock Board	NHECTS14073
74	Lock Washer	NHECTS14074
75	Spring Washer 6	NHECTS14075
76	Bolt M6x16	NHECTS14076
77	Support Board C	NHECTS14077
78	Spring Washer 5	NHECTS14078
79	Screw M5x20	NHECTS14079
80	Support Board A	NHECTS14080
81	Spring Washer 6	NHECTS14081
82	Bolt M6x40	NHECTS14082
83	Lock Pin 4x13	NHECTS14083
84	Bolt M6x16	NHECTS14084
85	Screw M8x20	NHECTS14085

No	Part Name	
86	Ø8 Washer	NHECTS14086
87	Blade Flange	NHECTS14087
88	Lock Pole1	NHECTS14088
89	Lock Pole2	NHECTS14089
90	Nut M6	NHECTS14090
91	Spring Washer 6	NHECTS14091
92	Bolt M6x16	NHECTS14092
93	Washer 8	NHECTS14093
94	Nut M8	NHECTS14094
95	Support Washer	NHECTS14095
95a	Washer 6	NHECTS14095A
95b	Nut M6	NHECTS14095B
96	Motor Cable	NHECTS14096
97	Cable Press Sheet	NHECTS14097
98	Flat Washer 4	NHECTS14098
99	Spring Washer 4	NHECTS14099
100	Screw M4x16	NHECTS14100
101	Gear Box	NHECTS14101
102	Bearing 698-2z	NHECTS14102
103	Lock Washer 15	NHECTS14103
104	Gear	NHECTS14104
105	Gear Shaft	NHECTS14105
105a	Key	NHECTS14105A
106	Lock Washer 35	NHECTS14106
107	Bearing 6003-z	NHECTS14107
108	Bearing Base	NHECTS14108
109	Screw M5x16	NHECTS14109
110	Return Sheet	NHECTS14110
111	Spring Washer	NHECTS14111
112	Lock Washer 45	NHECTS14112
113	Adjust Washer	NHECTS14113
114	Blade Flange	NHECTS14114
115	Blade	NHECTS14115
116	Tie Band	NHECTS14116
117	Soft Tube	NHECTS14117
117a	Lock Nut M5	NHECTS14117A
117b	Flat Washer 5	NHECTS14117B
117c	Spring Washer 5	NHECTS14117C
117d	Slide Table Locker	NHECTS14117D
117e	Screw M5x16	NHECTS14117E
118	Bolt M6x12	NHECTS14118
119	Spring Washer 6	NHECTS14119
120	Riving Knife Lock Sheet	NHECTS14120

No	Part Name	
121	Riving Knife	NHECTS14121
122	Adjust Board	NHECTS14122
123	Bolt M6x12	NHECTS14123
124	Spring Washer 6	NHECTS14124
125	Flat Washer 6	NHECTS14125
126	Carbon Brush Cover	NHECTS14126
127	Carbon Brush	NHECTS14127
128	Screw M4	NHECTS14128
129	Carbon Brush Holder	NHECTS14129
130	Housing	NHECTS14130
131	Screw M5x25	NHECTS14131
132	Spring Washer 5	NHECTS14132
133	Flat Washer	NHECTS14133
134	Stator	NHECTS14134
135	Rubber Bearing Base	NHECTS14135
136	Flat Washer	NHECTS14136
137	Spring Washer	NHECTS14137
138	Bearing 627-z	NHECTS14138
139	Screw M4x60	NHECTS14139
139a	Wind-proof Ring	NHECTS14139A
140	Rotor	NHECTS14140
141	Lock Washer 10	NHECTS14141
142	Bearing 6000-z	NHECTS14142
143	Screw St 4x10	NHECTS14143
144	Slide Table Cover 2	NHECTS14144
145	Sliding Lock Block	NHECTS14145
146	Slide Table Cover 4	NHECTS14146
147	Slide Table Cover 1	NHECTS14147
148	Left Slide Table	NHECTS14148
149	Slide Table Cover 3	NHECTS14149
150	Bearing 607-2z	NHECTS14150
150a	Eccenter Shaft	NHECTS14150A
151	Screw M5 X18	NHECTS14151
151a	Nut M6	NHECTS14151A
151b	Left Lower Table	NHECTS14151B
151c	Nut M5	NHECTS14151C
151d	Back Connection 2	NHECTS14151D
152	Back Support Sheet	NHECTS14152
153	Back Connection 1	NHECTS14153
154	Screw M5x16	NHECTS14154
155	Middle Table	NHECTS14155
156	Middle Table 2	NHECTS14156
156a	Right Table	NHECTS14156A

No	Part Name	
156b	Middle Table Support	NHECTS14156B
156c	Bolt M6x12	NHECTS14156C
157	Slide Table Connection	NHECTS14157
158	Nut M6	NHECTS14158
159	Table Scale	NHECTS14159
160	Bolt M6x12	NHECTS14160
161	Flat Washer 6	NHECTS14161
162	Pressure Board B	NHECTS14162
163	Pressure Board A	NHECTS14163
164	Lock Nut M6	NHECTS14164
165	Vac Tube	NHECTS14165
166	Adaptor	NHECTS14166
167	Seal Ring	NHECTS14167
168	Dust Tube Connection	NHECTS14168
168a	Arrow Label	NHECTS14168A
169	Table Guard A	NHECTS14169
170	Table Guard B	NHECTS14170
171	Screw St2.9x14	NHECTS14171
171a	Warning Label	NHECTS14171A
172	Screw M6x40	NHECTS14172
173	Nut M6	NHECTS14173
174	Steel Box	NHECTS14174
175	Push Stick Lock B	NHECTS14175
176	Cover	NHECTS14176
177	Push Stick Lock A	NHECTS14177
178	Rivet	NHECTS14178
179	Screw St4x10	NHECTS14179
F11	Ks Long Higher Bar	NHECTS14F11
F12	Ks Stand	NHECTS14F12
F13	Ks Long Lower Bar	NHECTS14F13
F14	Washer 6	NHECTS14F14
F15	Bolt M6x12	NHECTS14F15
F16	Flat Washer 8	NHECTS14F16
F17	Screw M8x10	NHECTS14F17
F18	Rubber Cover	NHECTS14F18
F19	Ks Short Lower Bar	NHECTS14F19
F110	Nut M6	NHECTS14F110
F111	Stand Rubber Foot	NHECTS14F111
F31	Angle Scale	NHECTS14F31
F32	Angle Fence Handle	NHECTS14F32
F33	Screw St4x8	NHECTS14F33
F34	Angle Pointer	NHECTS14F34
F35	Angle Fence Base	NHECTS14F35

No	Part Name	
F36	T Fence	NHECTS14F36
F37	Screw St 4x10	NHECTS14F37
F38	Pointer Base	NHECTS14F38
F39	Knob	NHECTS14F39
F41	Hex Key 6mm	NHECTS14F41
F42	Fork Spanner	NHECTS14F42
F43	Push Stick	NHECTS14F43
F51	Knob	NHECTS14F51
F52	Screw M4x6	NHECTS14F52
F53	Fence Cover A	NHECTS14F53
F54	Fence Cover C	NHECTS14F54
F55	Fence Pointer	NHECTS14F55
F56	Bolt M6x25	NHECTS14F56
F57	Fence	NHECTS14F57
F58	Fence Cover B	NHECTS14F58
F59	Fence Base	NHECTS14F59
F510	Fence Lock Fork	NHECTS14F510
F511	Fence Lock Sheet	NHECTS14F511
F512	Pin?6x20	NHECTS14F512
F513	Eccenter Frame	NHECTS14F513
F514	Screw M6x12	NHECTS14F514
F515	Eccent Wheel	NHECTS14F515
F516	Spring Pin?5x25	NHECTS14F516
F517	Angle Fence Handle	NHECTS14F517
F518	Handle Cover	NHECTS14F518
F62	Table Connection	NHECTS14F62
F63	Right Extension Table	NHECTS14F63
F64	Bolt M6x22	NHECTS14F64
F65	Nut M6	NHECTS14F65
F66	Extension Bar	NHECTS14F66
F67	Screw M5x8	NHECTS14F67
F68	Bolt M6x16	NHECTS14F68
F69	Slide Bar Base A	NHECTS14F69
F610	Lock Nut M6	NHECTS14F610
F611	Knob M6x20	NHECTS14F611
F612	Slide Bar Base B	NHECTS14F612
F613	Scale	NHECTS14F613
F614	Lock Nut M6	NHECTS14F614
F615	Front Connection	NHECTS14F615
F616	Bolt M6x12	NHECTS14F616

DECLARATION OF CONFORMITY



Clarke[®]
INTERNATIONAL

Hemnall Street, Epping, Essex CM16 4LG

DECLARATION OF CONFORMITY

This is an important document and should be retained.

We hereby declare that this product(s) complies with the following directive(s):

2004/108/EC *Electromagnetic Compatibility Directive.*

2006/42/EC *Machinery Directive.*

2011/65/EU *Restriction of Hazardous substances.*

The following standards have been applied to the product(s):

EN 55014-1:2006 +A2:2011, EN 55014-2:1997+A2:2008, EN 61000-3-2:2006+A2:2009,

EN 61000-3-11:2000, EN 61029-1:2009 +A11:2010, EN 61029-2-1:2010.

The technical documentation required to demonstrate that the product(s) meet(s) the requirement(s) of the aforementioned directive(s) has been compiled and is available for inspection by the relevant enforcement authorities.

The CE mark was first applied in: 2011

Product Description: Table saw
Model number(s): CTS14
Serial / batch Number: N/A
Date of Issue: 03/02/2014

Signed:

J.A. Clarke
Director

A SELECTION FROM THE VAST RANGE OF

Clarke®

QUALITY PRODUCTS

AIR COMPRESSORS

From DIY to industrial, Plus air tools, spray guns and accessories.

GENERATORS

Prime duty or emergency standby for business, home and leisure.

POWER WASHERS

Hot and cold, electric and engine driven - we have what you need

WELDERS

Mig, Arc, Tig and Spot. From DIY to auto/industrial.

METALWORKING

Drills, grinders and saws for DIY and professional use.

WOODWORKING

Saws, sanders, lathes, mortisers and dust extraction.

HYDRAULICS

Cranes, body repair kits, transmission jacks for all types of workshop use.

WATER PUMPS

Submersible, electric and engine driven for DIY, agriculture and industry.

POWER TOOLS

Angle grinders, cordless drill sets, saws and sanders.

STARTERS/CHARGERS

All sizes for car and commercial use.



PARTS & SERVICE: 020 8988 7400

E-mail: Parts@clarkeinternational.com or Service@clarkeinternational.com

SALES: UK 01992 565333 or Export 00 44 (0)1992 565335

Clarke® INTERNATIONAL Hemnall Street, Epping, Essex CM16 4LG
www.clarkeinternational.com