

Keysight W5643A DDR5 and W4640 / 30 Series DDR4 BGA Interposers

Installation Guide

Notices

© Keysight Technologies 2020

No part of this manual may be reproduced in any form or by any means (including electronic storage and retrieval or translation into a foreign language) without prior agreement and written consent from Keysight Technologies as governed by United States and international copyright laws.

Manual Part Number

W4631-97000

Edition

Seventh Edition, March 2020

Available in electronic format only

Keysight Technologies
1900 Garden of the Gods Road
Colorado Springs, CO 80907 USA

Warranty

THE MATERIAL CONTAINED IN THIS DOCUMENT IS PROVIDED "AS IS," AND IS SUBJECT TO BEING CHANGED, WITHOUT NOTICE, IN FUTURE EDITIONS. FURTHER, TO THE MAXIMUM EXTENT PERMITTED BY APPLICABLE LAW, KEYSIGHT DISCLAIMS ALL WARRANTIES, EITHER EXPRESS OR IMPLIED WITH REGARD TO THIS MANUAL AND ANY INFORMATION CONTAINED HEREIN, INCLUDING BUT NOT LIMITED TO THE IMPLIED WARRANTIES OF MERCHANTABILITY AND FITNESS FOR A PARTICULAR PURPOSE. KEYSIGHT SHALL NOT BE LIABLE FOR ERRORS OR FOR INCIDENTAL OR CONSEQUENTIAL DAMAGES IN CONNECTION WITH THE FURNISHING, USE, OR PERFORMANCE OF THIS DOCUMENT OR ANY INFORMATION CONTAINED HEREIN. SHOULD KEYSIGHT AND THE USER HAVE A SEPARATE WRITTEN AGREEMENT WITH WARRANTY TERMS COVERING THE MATERIAL IN THIS DOCUMENT THAT CONFLICT WITH THESE TERMS, THE WARRANTY TERMS IN THE SEPARATE AGREEMENT WILL CONTROL.

Technology Licenses

The hardware and/or software described in this document are furnished under a license and may be used or copied only in accordance with the terms of such license.

U.S. Government Rights

The Software is "commercial computer software," as defined by Federal Acquisition Regulation ("FAR") 2.101. Pursuant to FAR 12.212 and 27.405-3 and Department of Defense FAR Supplement ("DFARS") 227.7202, the U.S. government acquires commercial computer software under the same terms by which the software is customarily provided to the public. Accordingly, Keysight provides the Software to U.S. government customers under its standard commercial license, which is embodied in its End User License Agreement (EULA), a copy of which can be found at

<http://www.keysight.com/find/sweula>.

The license set forth in the EULA represents the exclusive authority by which the U.S. government may use, modify, distribute, or disclose the Software. The EULA and the license set forth therein, does not require or permit, among other things, that Keysight: (1) Furnish technical information related to commercial computer software or commercial computer software documentation that is not customarily provided to the public; or (2) Relinquish to, or otherwise provide, the government rights in excess of these rights customarily provided to the public to use, modify, reproduce, release, perform, display, or disclose commercial computer software or commercial computer software documentation. No additional government requirements beyond those set forth in the EULA shall apply, except to the extent that those terms, rights, or licenses are explicitly required from all providers of commercial computer software pursuant to the FAR and the DFARS and are set forth specifically in writing elsewhere in the EULA. Keysight shall be under no obligation to update, revise or otherwise modify the Software. With respect to any technical data as defined by FAR 2.101, pursuant to FAR 12.211 and 27.404.2 and DFARS 227.7102, the U.S. government acquires no greater than Limited Rights as defined in FAR 27.401 or DFAR 227.7103-5 (c), as applicable in any technical data.

Safety Notices

CAUTION

A CAUTION notice denotes a hazard. It calls attention to an operating procedure, practice, or the like that, if not correctly performed or adhered to, could result in damage to the product or loss of important data. Do not proceed beyond a CAUTION notice until the indicated conditions are fully understood and met.

WARNING

A WARNING notice denotes a hazard. It calls attention to an operating procedure, practice, or the like that, if not correctly performed or adhered to, could result in personal injury or death. Do not proceed beyond a WARNING notice until the indicated conditions are fully understood and met.

In This Guide

This guide provides installation and usage information for the following Keysight DDR5 and DDR4 BGA interposers and the cables used with these interposers.

W5643A DDR5 78-ball DRAM BGA Interposer and Cables

- W5643A DDR5 x4/x8 BGA 2-Wings Interposer
- U4208A 61 pin ZIF Cable (for connecting to P2 wing of W5643A)
- U4209A 61 pin ZIF Cable (for connecting to P1 wing of W5643A)

W4630-series DDR4 DRAM BGA Interposers and Cables

- W4633A DDR4 x4/x8 BGA Command and Data Interposer
- W4631A DDR4 x16 BGA Command and Data Interposer
- W4636A DDR4 x16 KOV BGA 2-Wings Command and Reduced Data Interposer
- E5849A High Data Rate Single-ended ZIF Cable (for use with the W4633A and W4631A interposers)
- E5847A High Data Rate Single-ended ZIF Cable (for use with the W4636A interposer)

W4640-series DDR4 DRAM BGA Interposers and Cables

- W4643A DDR4 x4/x8 BGA 2-Wings Interposer
- W4641A DDR4 x16 BGA 2-Wings Interposer
- U4208A 61 pin ZIF for Left Wing, Probe/Cable Combination (for use with W4641A and W4643A interposers)
- U4209A 61 pin ZIF for Right Wing, Probe/Cable Combination (for use with W4641A and W4643A interposers)

DDR3 Probes

Keysight also offers equivalent probes for DDR3 memory:

- W3631A DDR3 x16 BGA address/control/data probe for stacked DRAM under 2G.
- W3633A DDR3 x4/x8 BGA address/control/data probe.
- W3636A DDR3 x16 non-stacked DRAM 96 ball BGA probe.
- E5845A adapter cable for W3631A and W3636A probes.
- E5847A adapter cable for W3633A probe.
- W3635B DDR3 oscilloscope probe adapter.

You can find installation and usage information for DDR3 probes in the *Keysight W3630-Series DDR3 DRAM BGA Probes Installation Guide* (part number W3631-97004). The guide is available for download on www.keysight.com.

Contents

In This Guide 3

1 Introduction to W5643A 78-ball Interposer

W5643A DDR5 78-ball BGA 2-Wings Interposer - Overview	12
Compatibility with Logic Analyzer Modules	13
DDR5 Signals Probing and Analysis using the W5643A and U4164A Combination	13
W5643A Technical Features Summary	13
W5643A Riser and Optional Grypper Socket	14
U4208A 61-pin ZIF Probe / Cable (Connecting to P2 Wing of W5643A)	15
U4209A 61-pin ZIF Probe / Cable (Connecting to P1 wing on W5643A)	16
Hardware and Software Requirements	17
Mechanical Considerations	18
W5643A Interposer Dimensions	18
W5643A Riser Dimensions	18
W5643A Solder Balls and RC Components Dimensions	19
Providing Clearance to Components	20
W5643A Keep-Out Volume	21

2 Introduction to W4630-Series Interposers

W4630 Series DDR4 BGA Interposers - Overview	24
Compatibility with Logic Analyzer Modules	24
W4633A DDR4 x4/x8 BGA Interposer	25
W4633A Technical Features Summary	25
W4633A Riser and Optional Grypper Socket	26
W4631A DDR4 x16 BGA Interposer	27
W4631A Technical Features Summary	27
W4631A Riser and Optional Grypper Socket	28
W4636A DDR4 x16 KOV BGA 2-Wings Command and Reduced Data Interposer	29
W4636A Technical Features Summary	30
E5849A Single-ended ZIF Probe Cable	31
E5847A Single-ended ZIF Probe Cable	32
U4201A 90-pin Logic Analyzer Cables	33

Hardware and Software Requirements	34
Mechanical Considerations	36
W4633A Interposer Dimensions	36
W4633A Keep-Out Volume	37
W4631A Interposer Dimensions	40
W4631A Keep-Out Volume	40
W4636A Interposer Dimensions	42
W4636A Keep-Out Volume	42

3 Introduction to W4640-Series Interposers

W4640-Series DDR4 BGA Interposers - Overview	46
Compatibility with Logic Analyzer Modules	46
W4643A DDR4 x4/x8 BGA 2-Wings Interposer	47
W4643A Technical Features Summary	47
W4643A Riser and Optional Grypper Socket	48
W4641A DDR4 x16 BGA 2-Wings Interposer	49
W4641A Technical Features Summary	49
W4641A Riser and Optional Grypper Socket	50
U4208A 61-pin ZIF Probe / Cable (Connecting to Left Wing (P1) of W4641A/W4643A)	51
U4209A 61-pin ZIF Probe / Cable (Connecting to Right Wing (P2) of W4641A/W4643A)	52
Hardware and Software Requirements	53
Mechanical Considerations	55
W4643A Interposer Dimensions	55
W4643A Riser Dimensions	55
W4643A Keep-Out Volume	56
W4641A Interposer Dimensions	58
W4641A Riser Dimensions	58
W4641A Keep-Out Volume	59

4 Interposer and Riser Soldering Guidelines

Recommended Soldering Guidelines	63
Soldering Steps	64
Interposer Fabrication Notes	66

5 Setting up the W5643A Interposer

W5643A Interposer Setup - Overview	68
Step 1 - Soldering the W5643A Interposer and Riser	69

Step 2 - Connecting the W5643A Interposer to U4208A and U4209A Probe Cables	70
Labeling the Probe Cables	70
W5643A Interposer and U4208A / U4209A Probe Cable Connection and Orientation	71
Step 3 - Connecting the U4208A and U4209A Probe Cables to a U4164A Logic Analyzer	72
W5643A Interposer Wings Pinout	73
Logic Analyzer Channels to Signals Mapping	75
6 Setting up the W4633A Interposer	
W4633A Interposer Setup - Overview	78
Soldering the W4633A Interposer and Riser	79
Connecting the W4633A Interposer to E5849A Probe Cables	80
W4633A Interposer Wings Pinout	82
Connecting the E5849A Probe Cables to a Logic Analyzer	84
Logic Analyzer Channel Mapping	84
Signals not probed by the Logic Analyzer	85
7 Setting up the W4631A Interposer	
W4631A Interposer Setup - Overview	88
Mounting a W4631A Interposer on a PC Board using Riser and/or Sockets	89
Before Starting the Mounting Procedure	89
To mount the W4631A interposer on a PC board	90
Connecting the W4631A Interposer to E5849A Probe Cables	93
W4631A Interposer Wings Pinout	95
Connecting the E5849A Probe Cables to a Logic Analyzer	97
E5849A Cables to Logic Analyzer Pods Connection Mapping (for < 2.5 Gb/s Data Rates)	98
DDR4 x16 ZIF Cable to Logic Analyzer Pods Connection Mapping (for < and > 2.5 Gb/s Data Rates)	98
Logic Analyzer Channel Mapping	98
Signals not probed by the Logic Analyzer	101
8 Setting up the W4636A Interposer	
W4636A Interposer Setup - Overview	104
Soldering the W4636A Interposer	105
Connecting the W4636A Interposer to an E5847A Probe Cable	106
W4636A Interposer Wings Pinout	107

Connecting the E5847A Probe Cable to a Logic Analyzer 109

- Logic Analyzer Channel Mapping 109
- Signals not probed by the Logic Analyzer 110

9 Setting up the W4643A Interposer

W4643A Interposer Setup - Overview 114

Soldering the W4643A Interposer and Riser 115

Connecting the W4643A Interposer to U4208A and U4209A Probe Cables 116

- W4643A Interposer Wings Pinout 117

Connecting the U4208A and U4209A Probe Cables to a U4164A Logic Analyzer 119

- Logic Analyzer Channels to Signals Mapping 120
- Signals not probed by the Logic Analyzer 121

10 Setting up the W4641A Interposer

W4641A Interposer Setup - Overview 124

Soldering the W4641A Interposer 125

Connecting the W4641A Interposer to U4208A and U4209A Probe Cables 126

- W4641A Interposer Wings Pinout 127

Connecting the U4208A and U4209A Probe Cables to a U4164A Logic Analyzer 129

- Logic Analyzer Channels to Signals Mapping 130
- Signals not probed by the Logic Analyzer 131

11 Setting Up the Logic Analyzer for W5643A and W4630/40-Series Interposers

Before You Start 134

Using DDR Setup Assistant 135

Loading a Configuration File 136

- To save a configuration file 137

12 Characteristics, Regulatory, Safety and Storage Information

Operating Characteristics 140

Storage, Inspection, Baking, and Cleaning Guidelines 141

- Guidelines for Shelf Life and Solder-ability of Interposers 141
- Cleaning of Interposer Gold Fingers 141

Safety Checks and Warnings 142

Safety Information for the E5849A and E5847A Cable Adapters 143

- To clean the instrument 143
- Safety Symbols 143

Regulatory Notices	144
WEEE Compliance	144
China RoHS	144

Index

1 Introduction to W5643A 78-ball Interposer

W5643A DDR5 78-ball BGA 2-Wings Interposer - Overview / 12
Compatibility with Logic Analyzer Modules / 13
DDR5 Signals Probing and Analysis using the W5643A and U4164A Combination / 13
W5643A Technical Features Summary / 13
W5643A Riser and Optional Grypper Socket / 14
U4208A 61-pin ZIF Probe / Cable (Connecting to P2 Wing of W5643A) / 15
U4209A 61-pin ZIF Probe / Cable (Connecting to P1 wing on W5643A) / 16
Hardware and Software Requirements / 17
Mechanical Considerations / 18
W5643A Interposer Dimensions / 18
W5643A Riser Dimensions / 18
W5643A Solder Balls and RC Components Dimensions / 19
Providing Clearance to Components / 20
W5643A Keep-Out Volume / 21

This chapter introduces the hardware components needed for the W5643A interposer setup. It also lists the software requirements as well as describes the mechanical considerations such as various dimensions and KOV that you should know before you start setting up and using this interposer.

W5643A DDR5 78-ball BGA 2-Wings Interposer - Overview

The W5643A DDR5 DRAM BGA Interposer enables probing of 78-ball DDR5 x4/x8 DRAM directly at the ball grid array using the Keysight U4164A logic analyzer.

Using this interposer, you can capture DDR5 CA, CMD, and DQ signals for data rates above 3800 MT/s. It provides access to DDR5 DQ signals without double probe load by utilizing the Quad Sampling features of a U4164A logic analyzer. Refer to [page 13](#) to know more about DDR5 signals probing and analysis using the W5643A and U4164A setup.

This interposer is designed to be soldered to the PCB footprint for the DRAM either directly (if there is sufficient KOV) or using either the riser included with the interposer or an optional Grypper socket (not included with the interposer). The DDR5 DRAM being probed is soldered to the top side of the interposer.

Each DRAM signal in the common footprint passes directly from the bottom side of the interposer to the top side of the interposer.

The following figure shows a W5643A DDR5 BGA interposer's top view.

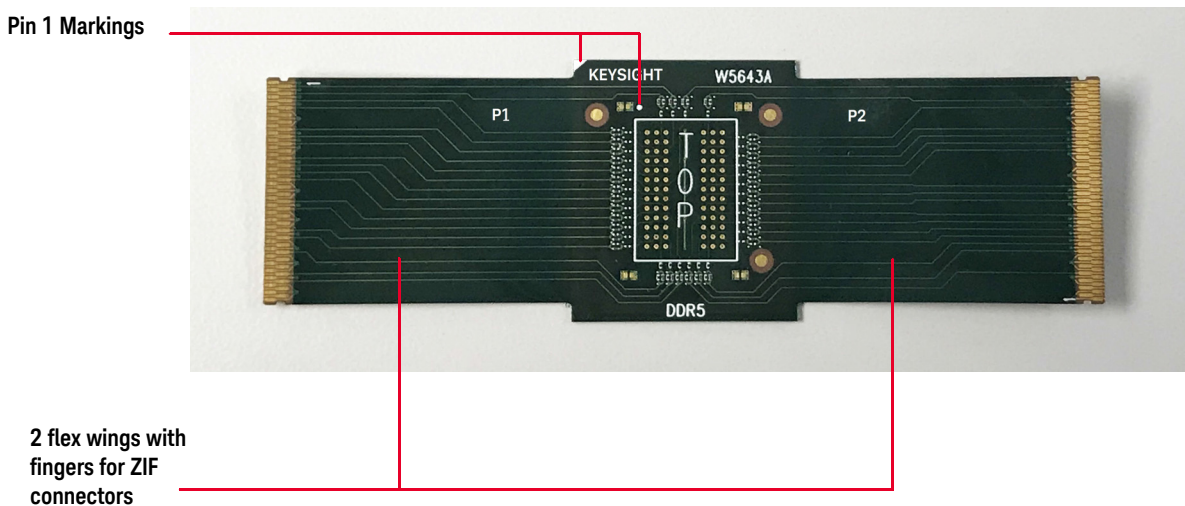

Figure 1 W5643A DDR5 x4/x8 BGA Interposer

The W5643A is a flexible interposer with two wings, each with a set of fingers for Zero Insertion Force (ZIF) connections that connect it to a U4208A or a U4209A 61-pin ZIF probe/cable. For the P1 wing of the interposer, you use the U4209A probe/cable and for the P2 wing of the interposer, you use the U4208A probe/cable. These cables are then connected to the U4164A Logic Analyzer module's pods.

NOTE

The connections and orientation of the U4208A and U4209A probe cables with the W5643A interposer is different from the way these cables connect to the W4643A and W4641A DDR4 BGA interposers. For the W5643A interposer, these cables connect to opposite wings and upside down compared to the way these connect to the W4643A and W4641A DDR4 BGA interposers. See [page 71](#) to know more about these cable connections.

NOTE

The W5643A interposer is tested for via connections through the interposer and signal trace connectivity to the wing connections.

Compatibility with Logic Analyzer Modules

The W5643A interposer is compatible with the Keysight U4164A AXIe-based logic analyzer module with speed upgrade option U4164A-02G.

NOTE

The speed upgrade option U4164A-02G is required because U4164A features such as single touch probing, quad sampling, and higher data rates (2.5 GHz clocking and 4 Gb/s data capture) are available only when you use this speed upgrade option.

DDR5 Signals Probing and Analysis using the W5643A and U4164A Combination

- **DQ signals** - The W5643A/U4164A combination can capture DDR5 DQ signals up to 4GT/s. The Quad sampling mode of the U4164A logic analyzer is used to capture DQ signals. In this mode, the logic analyzer captures Read Rising, Read Falling, Write Rising, and Write Falling samples simultaneously for each DQ. Four samples are taken per clock edge and two thresholds are used with two samples taken per threshold. Use the *B4661A-5FP/5TP/5NP DDR5 Analysis and Compliance Software* option with the U4164A logic Analyzer to analyze DDR5 CA and DQ traffic.
- **DQS signals** - The Quad sampling mode of the U4164A logic analyzer is used to capture DQS signals. Use the *Timing Zoom / DDR Eyescan* feature of the U4164A logic analyzer to view these signals.
- **CA signals** - The W5643A/U4164A combination can capture DDR5 CA signals up to 2500MHz, corresponding to DDR5 5000MT/s data rates. For DDR5 systems, CA signals are captured off one clock edge as CA is valid only on the rising edge of clock for DDR5 DRAMs.

NOTE

All probing including BGA interposers, become a part of the system under test when installed. Maximum data rates and performance results will vary by systems under test, BGA rework, and probing irregularities.

W5643A Technical Features Summary

- Probes a 78-ball DDR5 single channel x4/x8 DRAM chip. Maximum of 9 mm x 12 mm DDR5 DRAM package can fit on top of the W5643A interposer without an additional riser or a socket to provide clearance to the RC components.
- For the two flex wings of the interposer, the recommended bend radius is 1.27mm (0.05") if flex is bent at a rigid portion of the interposer.
- Logic analyzer connections are made using U4208A and U4209A ZIF probe cables. The U4208A/U4209A ZIF connectors are attached to the top of the W5643A wings. Refer [page 71](#) to know about how to correctly connect and orient the cables and interposer.
- RC components network is present on the W5643A interposer. No RC network present on the U4208A/U4209A probe cables. Also, there are no RCs on the bottom of the interposer.

W5643A Riser and Optional Grypper Socket

An optional DDR5 78-ball riser is provided with each W5643A interposer to allow the interposer to clear surrounding devices. Optionally, you can use a Grypper socket (not provided with the interposer).

NOTE

The usage of the W5643A riser provides better signal integrity than a Grypper socket, due to the ground planes internal to the riser.

The following figure displays a riser that is provided with the W5643A interposer.

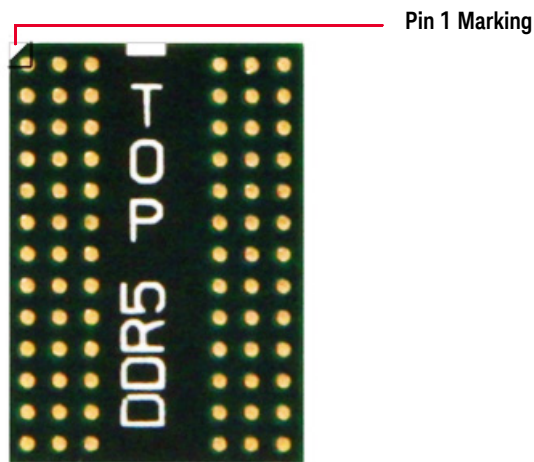

Figure 2 Riser that accompanies the W5643A interposer

NOTE

Due to ground planes, the riser's alignment with the DRAM should be such that the TOP side of the riser must point towards the DRAM and the Pin 1 indicator on the riser must orient towards the "A1" pin of the DRAM.

To know how to solder the riser to the W5643A interposer and PC board, refer to the chapter ["Interposer and Riser Soldering Guidelines"](#) on page 61.

U4208A 61-pin ZIF Probe / Cable (Connecting to P2 Wing of W5643A)

One U4208A probe cable is required to connect a W5643A interposer's right wing (P2) to a U4164A Logic Analyzer module.

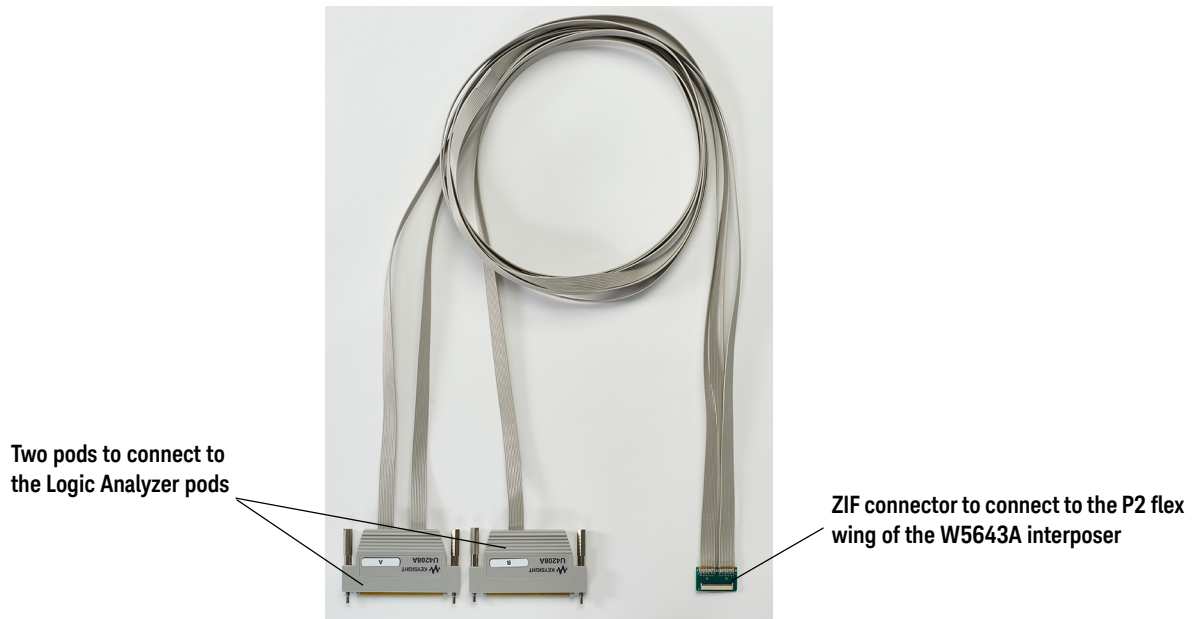

Figure 3 U4208A 61-pin ZIF probe cable

To know how to connect a W5643A interposer to a U4208A probe/cable, refer to the following topics in this guide:

- “Step 2 - Connecting the W5643A Interposer to U4208A and U4209A Probe Cables” on page 70
- “Step 3 - Connecting the U4208A and U4209A Probe Cables to a U4164A Logic Analyzer” on page 72

To get information such as its characteristics, specifications, pinout, safety information, accessories, and dimensions of the U4208A probe/cable, refer to the *Keysight U4200A-Series Probes and Cables User Guide* (part number U4200-97000) available on www.keysight.com.

NOTE

For the W5643A, the U4208A and U4209A probe cables connect to opposite wings and upside down compared to the way these connect to the W4643A and W4641A DDR4 BGA interposers.

U4209A 61-pin ZIF Probe / Cable (Connecting to P1 wing on W5643A)

One U4209A probe cable is required to connect a W5643A interposer's left wing (P1) to a U4164A Logic Analyzer module.

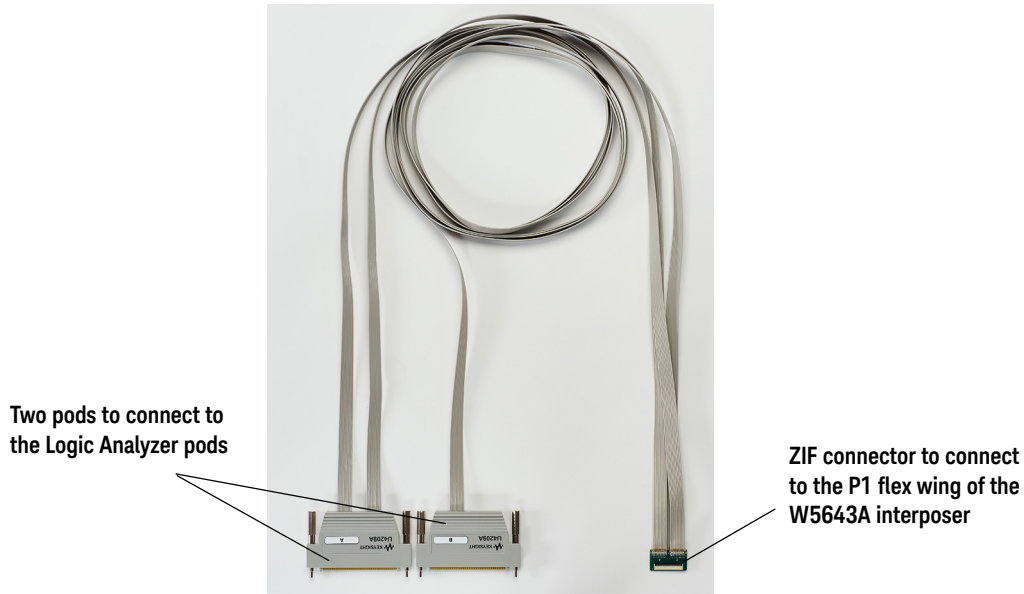

Figure 4 U4209A 61-pin ZIF probe cable

To know how to connect a W5643A interposer with a U4209A probe/cable, refer to the topics:

- “Step 2 - Connecting the W5643A Interposer to U4208A and U4209A Probe Cables” on page 70
- “Step 3 - Connecting the U4208A and U4209A Probe Cables to a U4164A Logic Analyzer” on page 72

To get information such as its characteristics, specifications, pinout, safety information, accessories, and dimensions of the U4209A probe/cable, refer to the *Keysight U4200A-Series Probes and Cables User Guide* (part number U4200-97000) available on www.keysight.com.

NOTE

For the W5643A, the U4208A and U4209A probe cables connect to opposite wings and upside down compared to the way these connect to the W4643A and W4641A DDR4 BGA interposers.

Hardware and Software Requirements

Before you start installing the W5643A probe, ensure that you have the following list of hardware and software components needed for these probes.

Hardware Requirements
U4164A AXIe-based Logic Analyzer Module
M9502A 2-slot or M9505A 5-slot AXIe chassis to install the U4164A module
M9537A embedded controller or host PC with PCI express adapter card for the chassis
W5643A DDR5 BGA Interposer(s)
U4208A 61-pin ZIF probe cable(s) connecting to P2 wing of the W5643A interposer to Logic Analyzer module (One cable is needed for each interposer)
U4209A 61-pin ZIF probe cable(s) connecting to P1 wing of the W5643A interposer to Logic Analyzer module (One cable is needed for each interposer)

Software Requirements	Licensing	Description
Logic and Protocol Analyzer software version 6.70 or higher. (Mandatory)	Not Licensed	Base software platform for configuring and using Keysight's logic analyzer modules.
B4661A--5FP/5TP/5NP DDR5 Analysis and Compliance SW version 6.70 or higher. (Recommended)	Licensed	A set of tools to: <ul style="list-style-type: none"> ▪ evaluate and analyze the captured DDR data. ▪ view DDR5 memory traffic. ▪ view decoded DDR5 transactions. ▪ view performance measurements. ▪ view distribution of memory accesses graphically. ▪ perform real-time or post process compliance.
DDR Setup Assistant and DDR Eyefinder software version 6.70 or higher. (Recommended)	Not Licensed	A wizard-like application that helps you set up your U4164A logic analyzer properly for DDR/LPDDR memory technologies State mode measurements for ADD/CMD/DATA capture and analysis.

NOTE

You can install the above-mentioned software components by downloading the required executables from the Keysight web site at:
www.keysight.com/find/lpa-sw-download.

The following table displays the number of W5643A BGA interposer and cables required to provide connections to channels of your logic analyzer module.

DRAM	Data Width	Access to	Number of Interposers	Number of ZIF Probes	Number of Logic Analyzer Modules
78-ball DDR5 DRAM	x4/x8	Command, Address, Control and Data	One W5643A	One U4208A for the P2 (right) wing of interposer One U4209A for the P1 (left) wing of interposer	One U4164A module

Mechanical Considerations

W5643A Interposer Dimensions

The following figure shows the dimensions of a W5643A interposer.

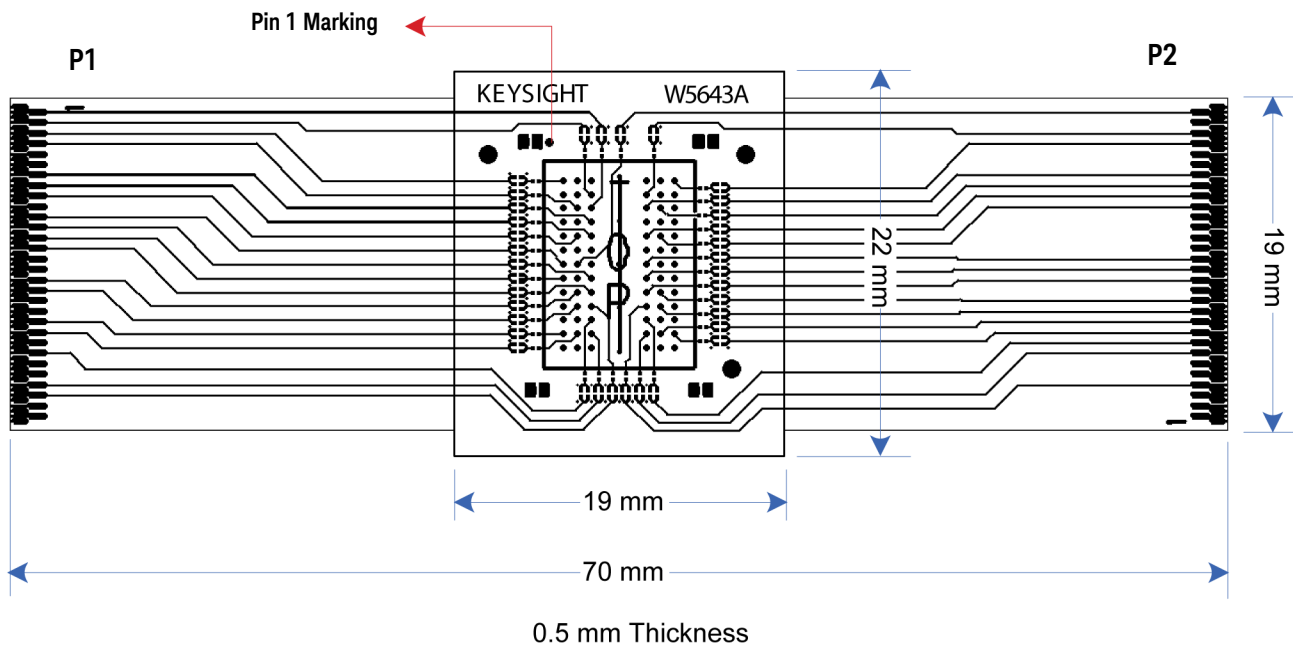
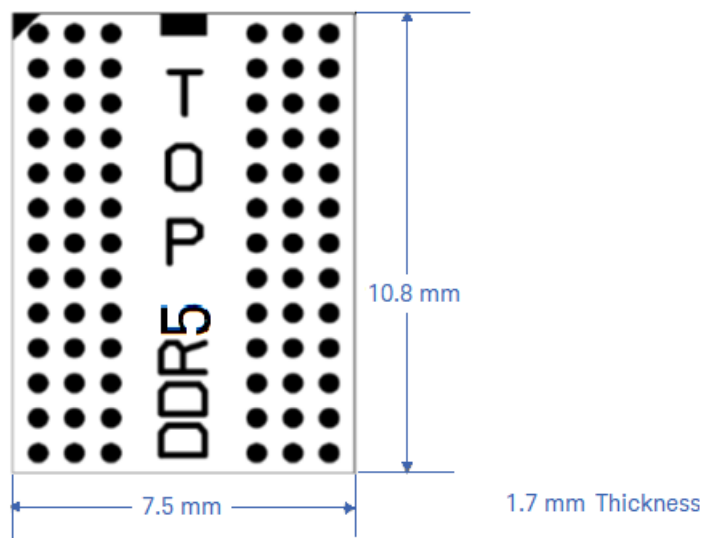

Figure 5 Dimensions of a W5643A interposer (TOP VIEW)

W5643A Riser Dimensions

All dimensions are in millimeters.



W5643A Solder Balls and RC Components Dimensions

The following figure displays the solder balls pattern and the locations of the RC components on top of the W5643A interposer with reference to the Pin A1 at 0,0. It also includes the height of the components located on top of the interposer to help you assess if your DRAM can fit on top of the interposer while providing the required clearance to the surface mount components.

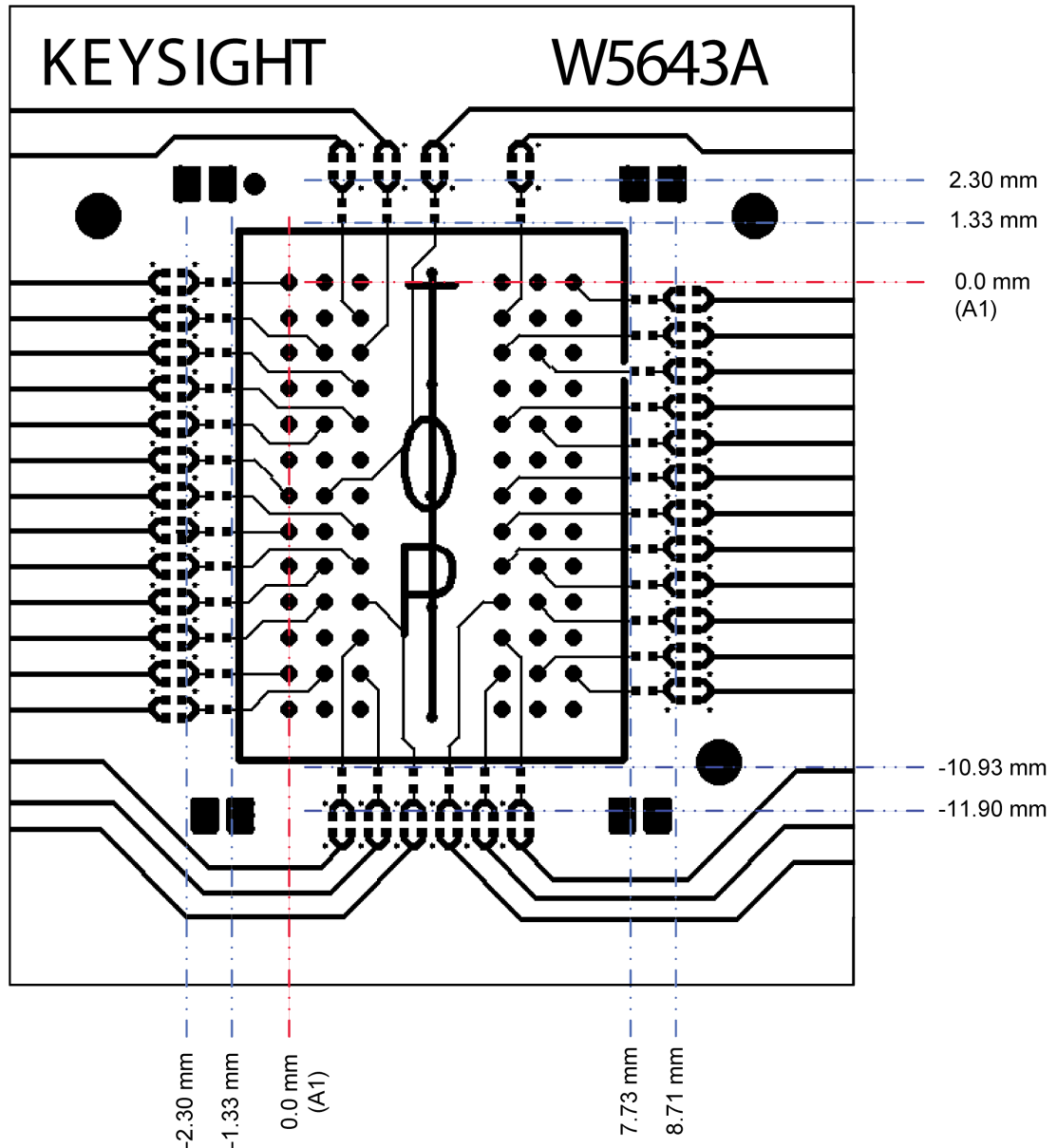

- Pin A1 - Reference location at 0,0
- Edges of the pads for the tip R : ~0.1 mm height
- Edges of the pads for RC components : 0.2 mm height

Providing Clearance to Components

A maximum of 9 mm x 12 mm DDR5 DRAM package can fit on top of the W5643A interposer without an additional riser or a socket on the top of the interposer and under DRAM. DDR5 DRAM packages may cover the surface mount components on the W5643A that surround the DRAM outline. This is allowed as long as there is clearance. If the DRAM package extends beyond the tip R, it may block the installation of the optional VDD and VDDQ power filter capacitors near the four corners of the BGA area.

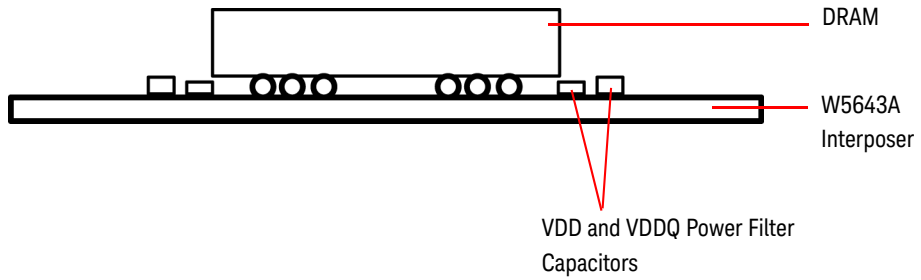

W5643A Keep-Out Volume

NOTE

You can install the W5643A interposer on a riser (shipped with the interposer) or a grypper socket to provide clearance to surrounding DRAM.

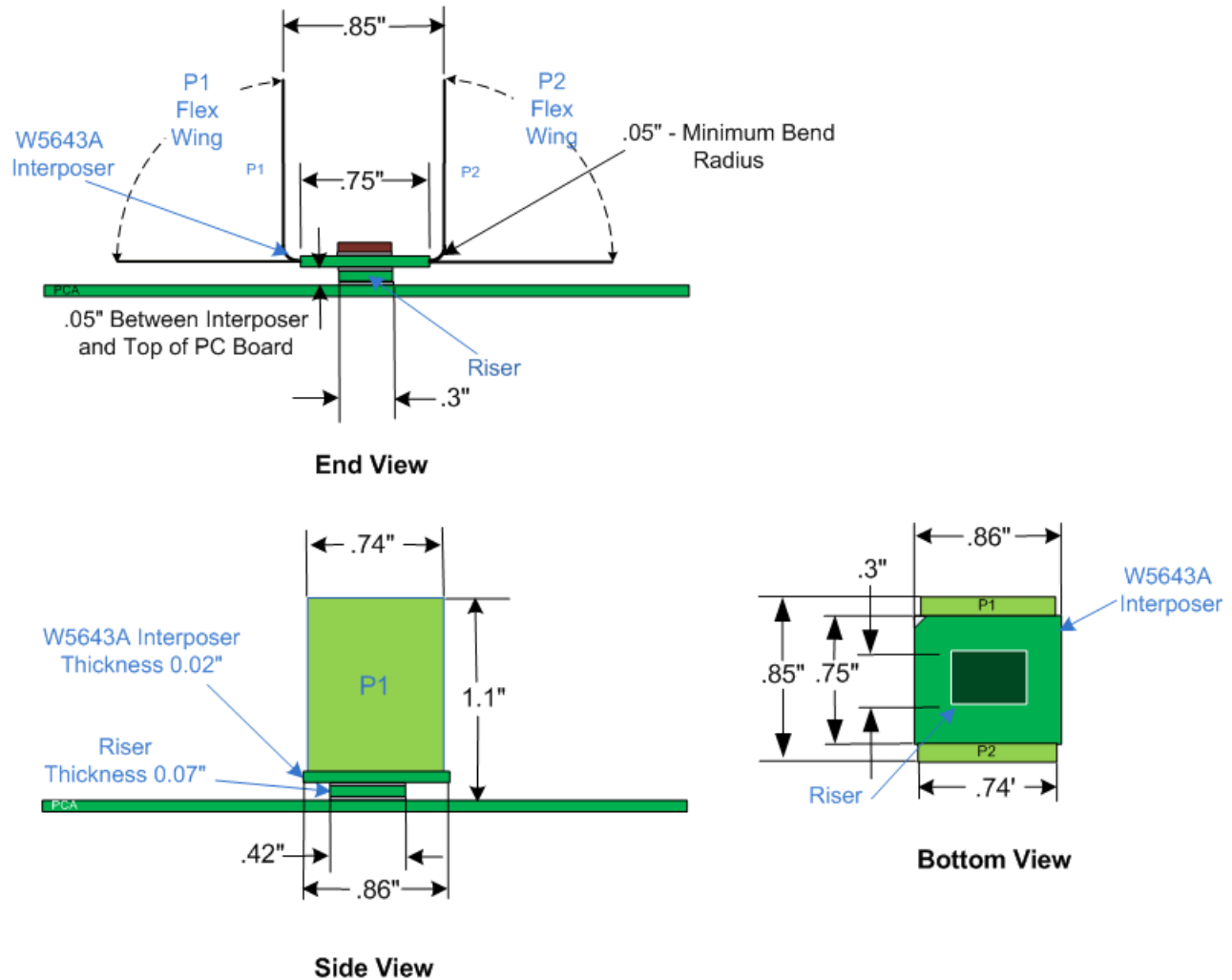

Figure 6 KOV of a W5643A interposer

2 Introduction to W4630-Series Interposers

W4630 Series DDR4 BGA Interposers - Overview /	24
W4633A DDR4 x4/x8 BGA Interposer /	25
W4631A DDR4 x16 BGA Interposer /	27
W4636A DDR4 x16 KOV BGA 2-Wings Command and Reduced Data Interposer /	29
E5849A Single-ended ZIF Probe Cable /	31
E5847A Single-ended ZIF Probe Cable /	32
U4201A 90-pin Logic Analyzer Cables /	33
Hardware and Software Requirements /	34
Mechanical Considerations /	36

This chapter introduces the hardware components that are needed for a W4630-series interposer setup. It also lists the software requirements as well as describes the mechanical considerations such as various dimensions and KOV that you should know before you start setting up and using these interposers.

W4630 Series DDR4 BGA Interposers - Overview

The W4630-series DDR4 DRAM BGA Interposers enable probing of embedded DDR4 DRAM (x4, x8, and x16) directly at the ball grid array using the Keysight logic analyzers.

The DDR4 interposers interpose between the DRAM being probed and the PC board where the DRAM would normally be soldered. The interposer is designed to be soldered to the PCB footprint for the DRAM on top of either the DDR4 riser included with the W4630 series BGA interposer or an optional Grypper socket (not included with the interposer) or both. The DRAM being probed is then soldered to the top side of the interposer.

Each DRAM signal in the common footprint passes directly from the bottom side of the interposer to the top side of the interposer. Buried probe resistors placed at the DRAM balls connect the probed signals to the rigid flex to mate with the E5849A/E5847A cables.

Currently, in this series, Keysight provides the following interposers:

- W4633A DDR4 x4/x8 BGA interposers with 78-ball riser
- W4631A DDR4 x16 BGA interposer with 96 balls riser
- W4636A DDR4 x16 KOV BGA 2-Wings Command and Reduced Data interposer for 96 balls DDR4 DRAM

Compatibility with Logic Analyzer Modules

The W4630A series interposers are compatible with the following models of Keysight AXIe-based logic analyzer modules.

- U4154A
- U4154B
- U4164A

NOTE

All W4630A series interposers are tested for via connections through the interposer and signal trace connectivity to the wing connections.

W4633A DDR4 x4/x8 BGA Interposer

The W4633A interposer has three flexible wings, each with a set of fingers for Zero Insertion Force (ZIF) connections that connect it to the E5849A single-ended ZIF probe adapter cables. These E5849A cables are then connected to the Logic Analyzer module's pods via U4201A logic analyzer cables.

The interposer comes with Resistor and Capacitor (RC) components installed on its top and bottom.

The following figure shows a W4633A DDR4 BGA interposer top side view, with RC components installed.

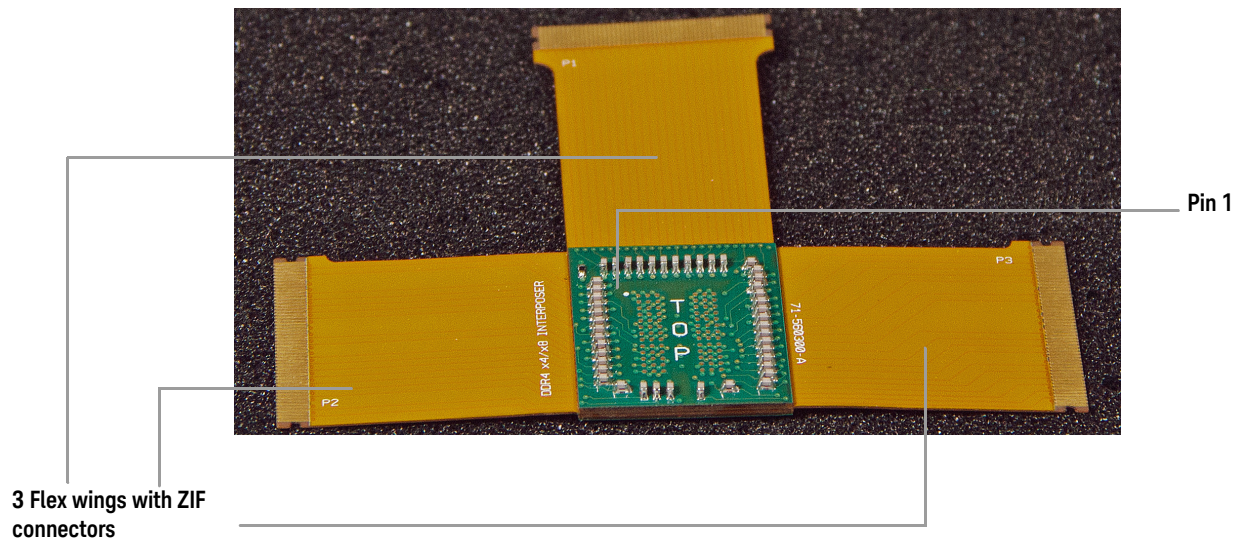

Figure 7 W4633A DDR4 x4/x8 BGA Interposer

W4633A Technical Features Summary

- Probes a 78-ball DDR4 single channel x4 or x8 DRAM chip, JEDEC MO-207M footprint variation DT-z. Maximum of 11 mm x 14 mm DDR4 DRAM package can fit on top of the W4633A interposer without an additional riser or a socket to provide clearance for the RC components.
- RC components network on the W4633A interposer:
 - ADD/CMD and half DATA RC on top of the interposer
 - Remaining half DATA RC on bottom of the interposer
- GND plane on the bottom side of the three flex wings of the interposer.
- For the three flex wings of the interposer, the recommended bend radius is 1.27MM (0.05") if flex is bent at a rigid portion of the interposer.
- Measurement timing skews within ± 25 psec achieved by matched trace lengths from DDR4 balls to test point.
- Logic analyzer connections are made using E5849A single ended ZIF probe cables. Doors of ZIF connectors attach to the bottom side of flex wings of the interposer.

W4633A Riser and Optional Grypper Socket

A DDR4 78-ball riser is provided with each W4633A interposer to provide clearance for bottom-side RC components on the interposer and to allow the interposer to clear surrounding devices. Optionally, you can use a Grypper socket. It is not provided with the interposer.

The following figure displays a riser that is provided with the W4633A interposer.

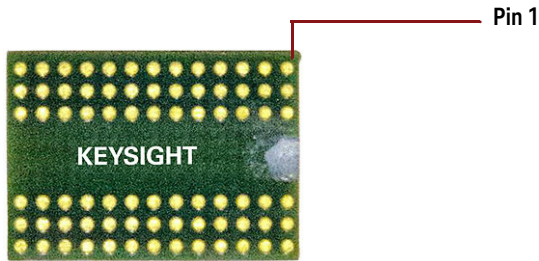

Figure 8 Riser that accompanies the W4633A interposer

NOTE

The DDR4 78-ball riser includes power and ground planes for optimal signal integrity. Due to the power and ground planes, the riser is only compatible with DDR4 78-ball DRAM.

To know how to solder the riser to the interposer and PC board, refer to the topic ["Soldering the W4633A Interposer and Riser"](#) on page 79.

W4631A DDR4 x16 BGA Interposer

The W4631A interposer has four flexible wings, each with a set of fingers for Zero Insertion Force (ZIF) connections that connect it to the right or left wing of the E5849A single-ended ZIF probe adapter cables. These E5849A cables are then connected to the Logic Analyzer module's pods via U4201A logic analyzer cables.

The interposer comes with Resistor and Capacitor (RC) components installed on its top and bottom.

The following figure shows a W4631A DDR4 BGA interposer top side view, with RC components installed.

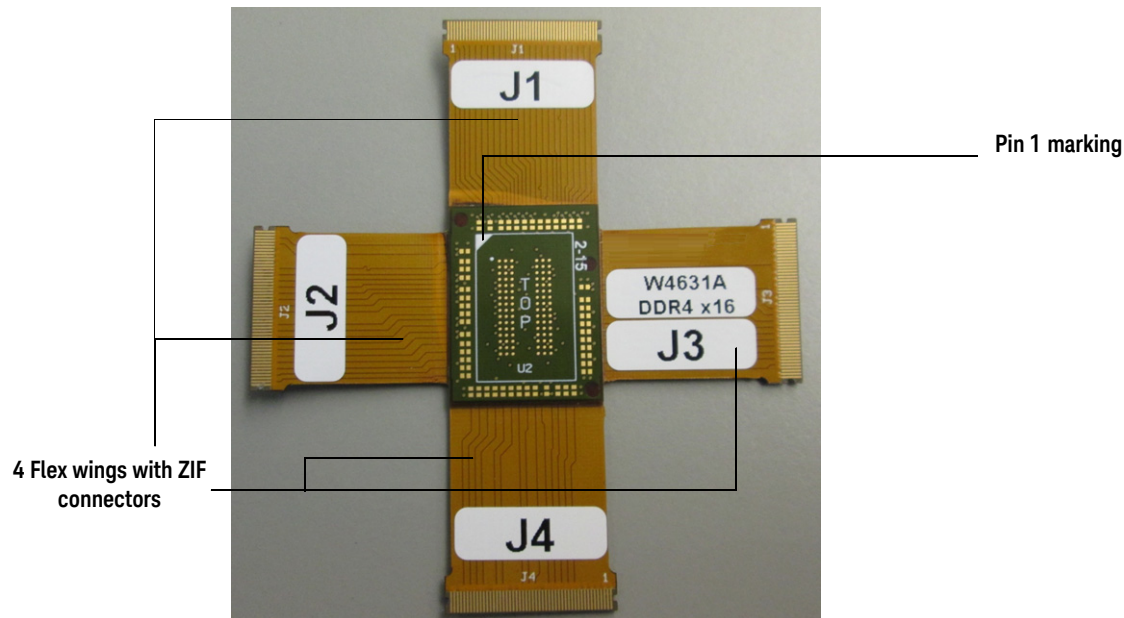

Figure 9 W4631A DDR4 x16 BGA Interposer

W4631A Technical Features Summary

- Probes a 96 ball DDR4 single channel x16 DRAM chip. Maximum of 12.5 mm x 19 mm DDR4 DRAM package can fit on top of the W4631A interposer without an additional riser or a socket to provide clearance for the RC components.
- RC components network on the W4631A interposer:
 - ADD/CMD and half DATA RC on top of the interposer
 - Remaining half DATA RC on bottom of the interposer
- GND plane on the bottom side of the four flex wings of the interposer.
- For the four flex wings of the interposer, the recommended minimum bend radius is 2.5 mm if flex is bent at a rigid portion of the interposer.
- Logic analyzer connections are made using E5849A single ended ZIF probe cables. Doors of ZIF connectors attach to the bottom side of flex wings of the interposer.

W4631A Riser and Optional Grypper Socket

A DDR4 96 ball riser is provided with each W4631A interposer to provide clearance for bottom-side RC components on the interposer and to allow the interposer to clear surrounding devices. Optionally, you can use a Grypper socket. It is not provided with the interposer.

The following figure displays the riser that is provided with the W4631A interposer.

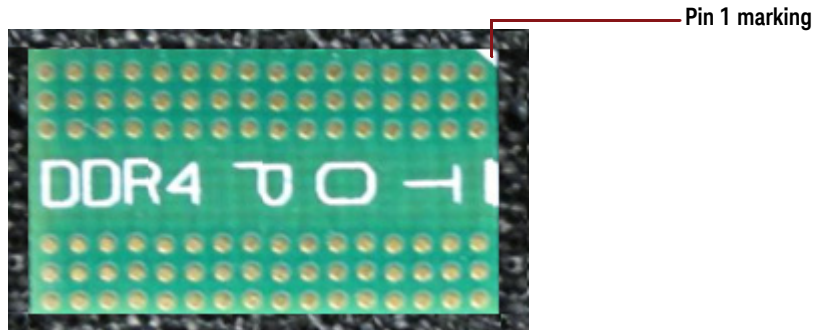

Figure 10 Riser that accompanies the W4631A interposer

CAUTION

The DDR4 96 balls riser includes power and ground planes for optimal signal integrity. Due to the power and ground planes, the riser is only compatible with DDR4 96 ball DRAM. Attaching this riser to a DDR3 target system can result in damaging the target system.

To know how to solder the riser to the interposer and PC board, refer to the topic ["Mounting a W4631A Interposer on a PC Board using Riser and/or Sockets"](#) on page 89.

W4636A DDR4 x16 KOV BGA 2-Wings Command and Reduced Data Interposer

The W4636A interposer probes a 96-balls DDR4 DRAM. When compared to the W4631A x16 interposer, W4636A offers two wings with limited signal access, reduced data rates, and a smaller KOV.

This interposer is suitable for use in the following situations:

- For data rates up to and including 2.4 Gb/s.
- For capturing all ADD/CMD but partial DQ/DQS (DQ1-DQ7 are not routed). If you require access to all ADD/CMD/DQ/DQS at data rates over 2.4 Gb/s, then you can use the W4633A x4/x8 and W4631A x16 DDR4 BGA interposers.
- For minimal KOV in space-limited systems under test

The following figure shows a W4636A interposer's top side view.

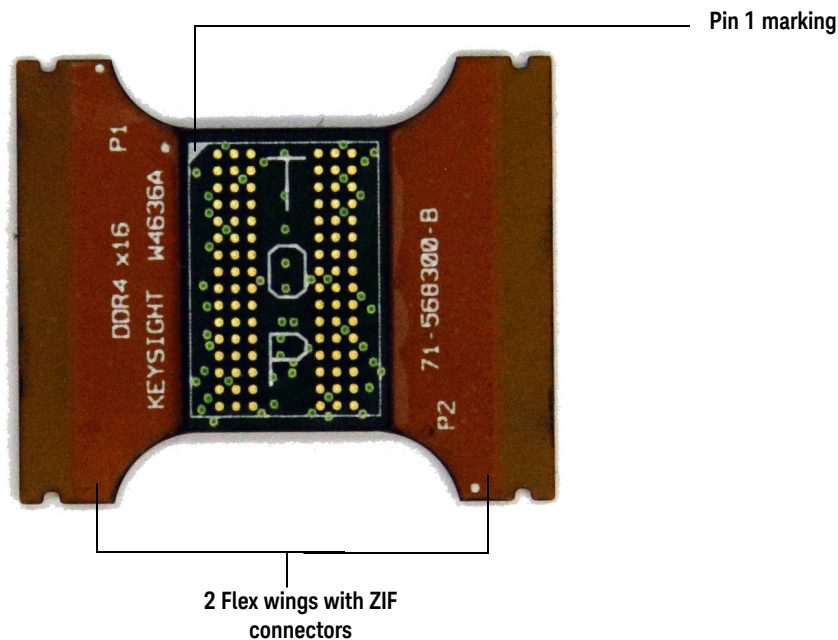

Figure 11 W4636A DDR4 x16 KOV BGA 2-Wings Command and Reduced Data Interposer

The W4636A interposer has two flexible wings, each with a set of fingers for Zero Insertion Force (ZIF) connections that connect it to the right or left wing of the E5847A single-ended ZIF probe adapter cables. These E5847A cables are then connected to the Logic Analyzer module's pods via U4201A logic analyzer cables.

In case of W4636A interposers, RC (resistor/capacitor) networks for logic analyzer probing are present on the E5847A ZIF cables and not on the interposer.

NOTE

No riser is required with the W4636A interposer. The interposer shipment, therefore, does not include any riser. You can optionally use a grypper socket which is sold separately at:

<http://www.hsiotech.com/products/released-products/engineering-products/grypper-family>

W4636A Technical Features Summary

- Probes a 96 ball DDR4 single channel x16 DRAM chip. Maximum of 12.5 mm x 19 mm DDR4 DRAM package can fit on top of the W4636A interposer.
- No RC components network on the W4636A interposer:
- For the two flex wings of the interposer, the recommended minimum bend radius is 1.27 mm if flex is bent at a rigid portion of the interposer.
- Logic analyzer connections are made using E5847A single ended ZIF probe cables. Doors of ZIF connectors attach to the top side of flex wings of the interposer.

E5849A Single-ended ZIF Probe Cable

Two E5849A probe cables are required to connect a W4631A / W4633A interposer to a Logic Analyzer module using U4201A logic analyzer cables.

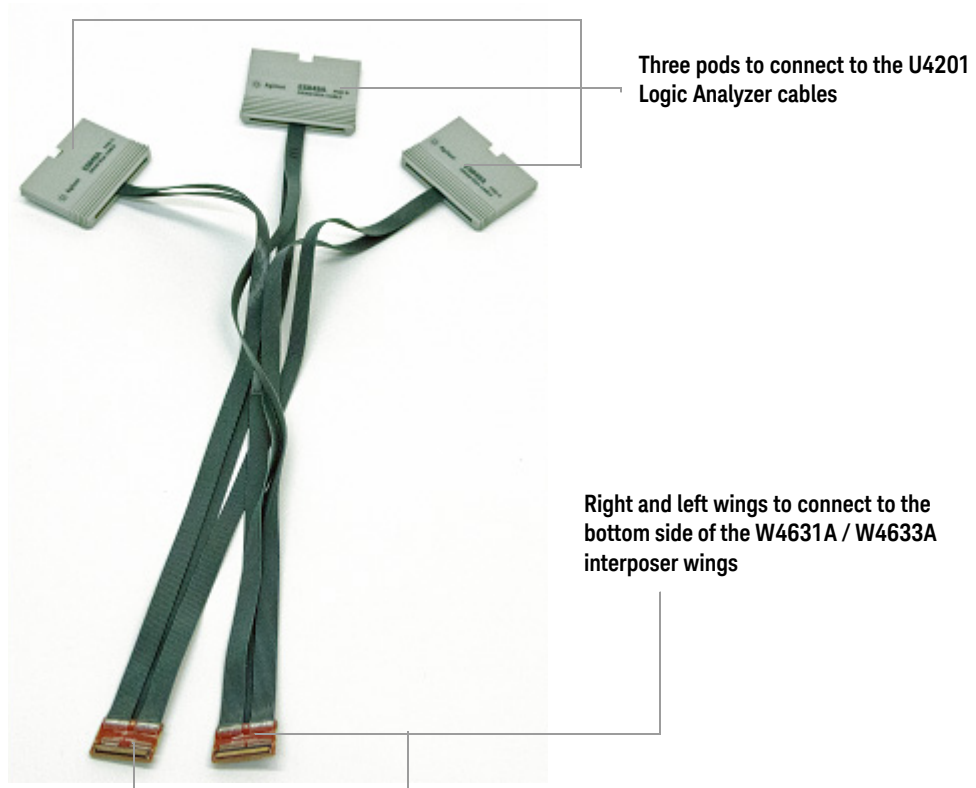

Figure 12 E5849A Single-ended ZIF probe cable

To know how to make connections between a W4631A or a W4633A interposer and E5849A probe cables, refer to the topics:

- ["Connecting the W4631A Interposer to E5849A Probe Cables"](#) on page 93
- ["Connecting the W4633A Interposer to E5849A Probe Cables"](#) on page 80

E5847A Single-ended ZIF Probe Cable

One E5847A probe cable is required to connect a W4636A interposer to a Logic Analyzer module using U4201A logic analyzer cables.

Three pods to connect to the U4201 Logic Analyzer cables

Right and left wings to connect to the W4636A interposer wings



Figure 13 E5847A Single-ended ZIF probe cable

To know how to make connections between a W4636A interposer and an E5849A probe cable, refer to the topic:

- ["Connecting the W4636A Interposer to an E5847A Probe Cable"](#) on page 106

U4201A 90-pin Logic Analyzer Cables

The U4201A logic analyzer cable connects a **E5849A** or **E5847A** probe cable to a pod of the U4154A/B AXIe-based logic analyzer module.

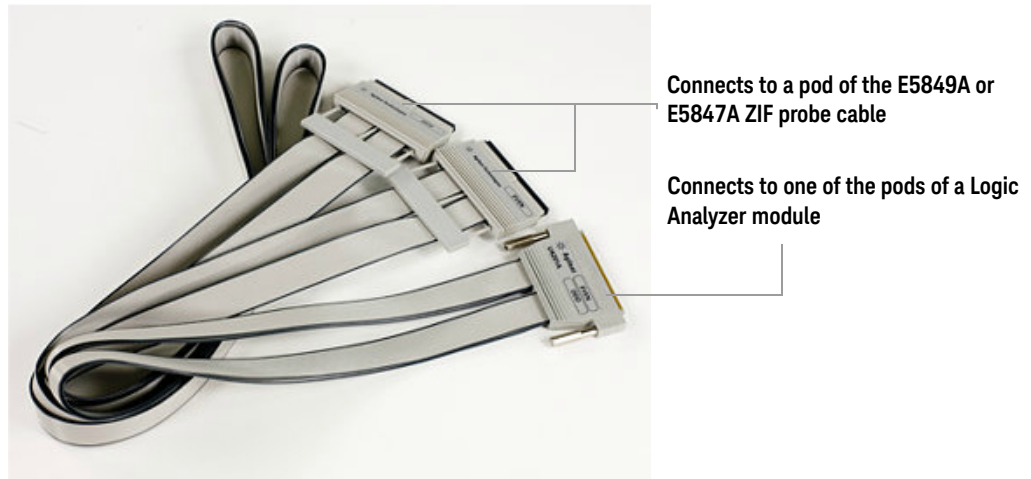

Figure 14 U4201A 90-pin logic analyzer cable

To know how to make connections between the U4201A cable and E5849A / E5847A probe cable, refer to the topics:

- ["Connecting the E5849A Probe Cables to a Logic Analyzer"](#) on page 97 (for W4631A)
- ["Connecting the E5849A Probe Cables to a Logic Analyzer"](#) on page 84 (for W4633A)
- ["Connecting the E5847A Probe Cable to a Logic Analyzer"](#) on page 109 (for W4636A)

Hardware and Software Requirements

Before you start installing the W4630-series probes, ensure that you have the following list of hardware and software components needed for these probes.

Hardware Requirements
U4164A or U4154A /B AXIe-based Logic Analyzer Module(s)
M9502A 2-slot or M9505A 5-slot AXIe chassis to install the U4154A module(s)
M9537A embedded controller or host PC with PCI express adapter card for the chassis
W4630A Series DDR4 BGA Interposer(s)
E5849A 46-ch single-ended ZIF probe cables to connect the W4631A or W4633A interposer to U4201A Logic Analyzer cables Two E5849A cables needed for each interposer
E5847A 46-ch single-ended ZIF probe cables to connect the W4636A interposer to U4201A Logic Analyzer cables One E5847A cable needed for each interposer
U4201A 90-pin Logic Analyzer cables to connect the E5849A or E5847A probe cables to U4154A/B module's analysis pods - Four U4201A cables needed for each W4633A interposer - Four U4201A cables needed for each W4631A interposer. - Three U4201A cables needed for each W4636A interposer.

Software Requirements	Licensing	Description
Logic and Protocol Analyzer software version 5.80 or higher. (Mandatory)	Not Licensed	Base software platform for configuring and using Keysight's logic analyzer modules.
B4621B DDR 2/3/4 Bus Decoder software version 5.80 or higher. (Recommended)	Licensed	Allows you to decode and view transactions, commands, and data from a DDR2, DDR3, or DDR4 memory bus in your target system.
B4622B DDR 2/3/4 Protocol Compliance and Analysis toolset version 5.80 or higher. (Recommended)	Licensed	A set of tools to: <ul style="list-style-type: none"> evaluate and analyze the captured DDR data. perform real-time or post process compliance. set up a trigger on the specified address. graphically profile the distribution of memory accesses.
DDR Setup Assistant and DDR Eyefinder software version 5.80 or higher. (Recommended)	Not Licensed	A wizard- like application that helps you set up your U4154A logic analyzer properly for DDR/LPDDR memory technologies State mode measurements for ADD/CMD/DATA capture and analysis.

NOTE

You can install the above-mentioned software components by downloading the required executables from the Keysight web site at: www.keysight.com/find/lpa-sw-download.

The following table displays the number of W4630A-series BGA interposers and cable adapters required to provide connections to channels of your logic analyzer module.

DRAM	Data Width	Access to	Number of Interposers	Number of ZIF Probes	Number of Cables	Number of Logic Analyzer Modules
x4	x4	Command, Address, Control and Data	One W4633A	Two E5849A	Four U4201A	One U4164A or U4154A/B module
x8	x8					
x16	x16	Command, Address, Control and Data	One W4631A	Two E5849A	Four U4201A	One U4164A or U4154A/B module for data rates up to and including 2.5 Gb/s
					Six U4201A	Two U4164A or U4154A/B modules for data rates over 2.5 Gb/s
					1 DDR4 x16 ZIF cable ordered through Keysight AEO	One U4164A or U4154A/B module for all data rates
x16	x16	Command, Address, Control and partial DQ/DQS	One W4636A	One E5847A	Three U4201A	One U4164A or U4154A/B module

Mechanical Considerations

W4633A Interposer Dimensions

The following figure shows the dimensions of a W4633A DDR4 DRAM BGA interposer.

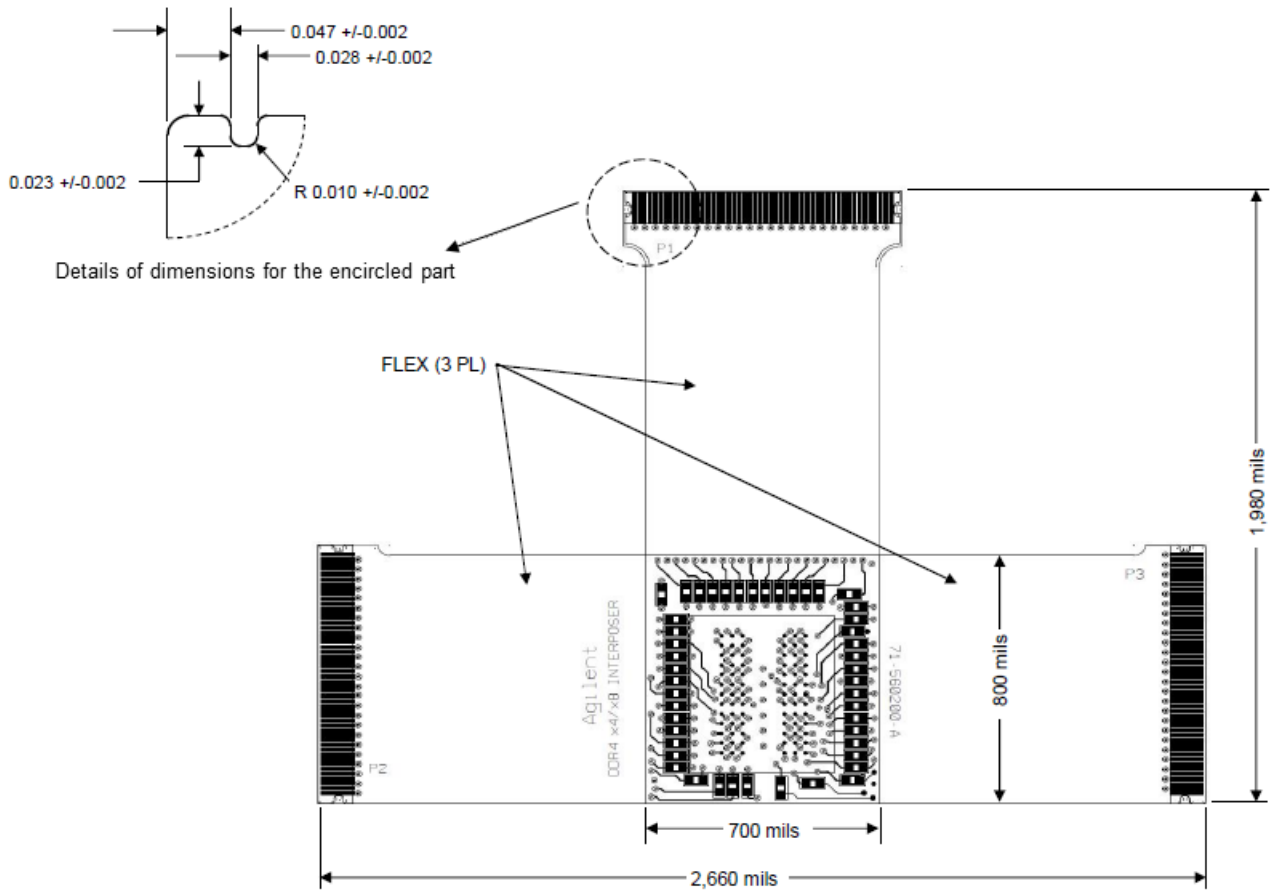

Figure 15 Dimensions of a W4633A interposer

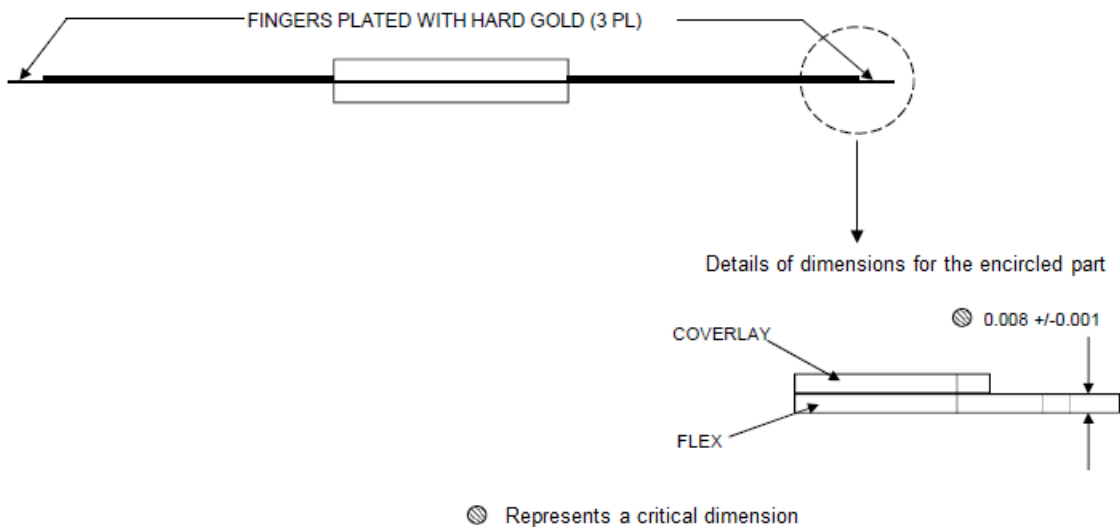
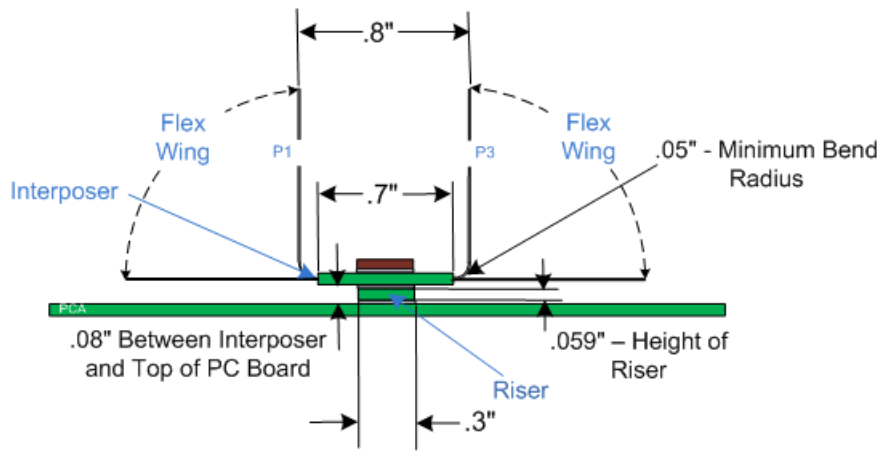

Figure 16 Dimensions of a W4633A interposer's signal finger

W4633A Keep-Out Volume

NOTE

You must install the W4633A interposer on a riser (shipped with the interposer) or a grypper socket to provide clearance to surrounding DRAM and RCs on the bottom side of the interposer.



End View

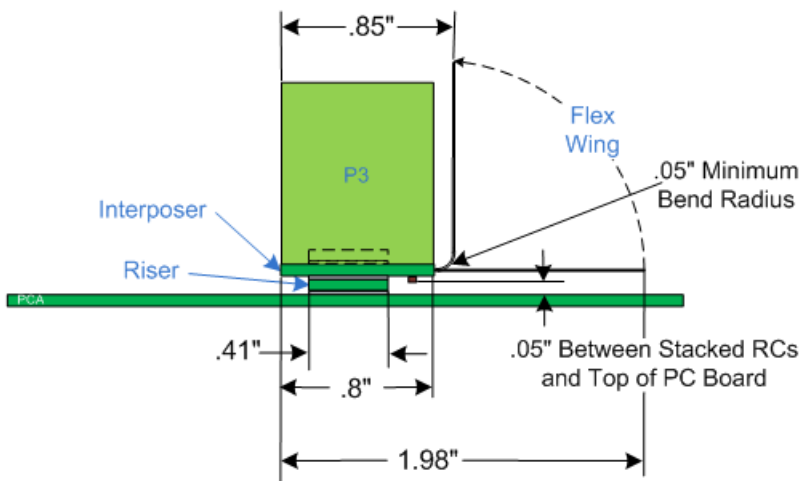

Side View

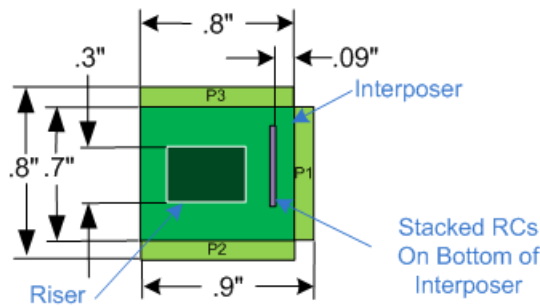

Bottom View

- Notes:**
- P1, P2 and P3 are the Interposer Wings
 - All Dimensions are Nominal

Figure 17 KOV of a W4633A interposer

The following figure shows the KOV of an E5849A probe cable when connected to a W4633A interposer.

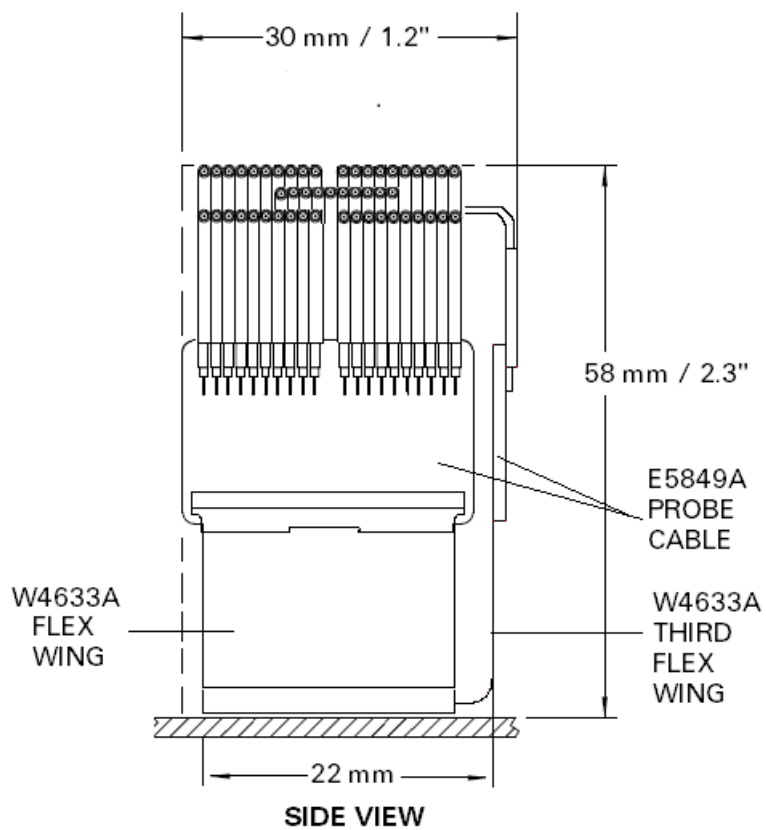

Figure 18 KOV of a W4633A interposer with an E5849A cable (SIDE VIEW)

W4631A Interposer Dimensions

The following figure shows the dimensions of a W4631A DDR4 DRAM BGA interposer.

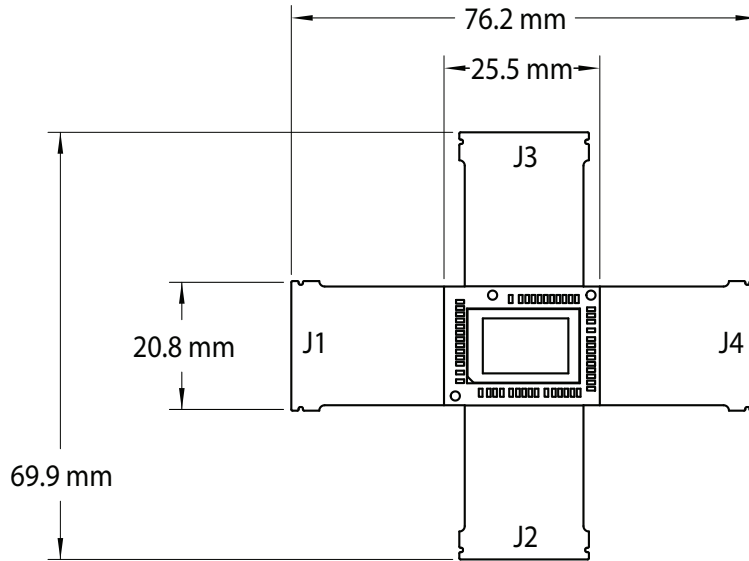

Figure 19 Dimensions of a W4631A interposer (TOP VIEW)

W4631A Keep-Out Volume

NOTE

You must install the W4631A interposer on a riser (shipped with the interposer) or a grypper socket to provide clearance to surrounding DRAM and RCs on the bottom side of the interposer.

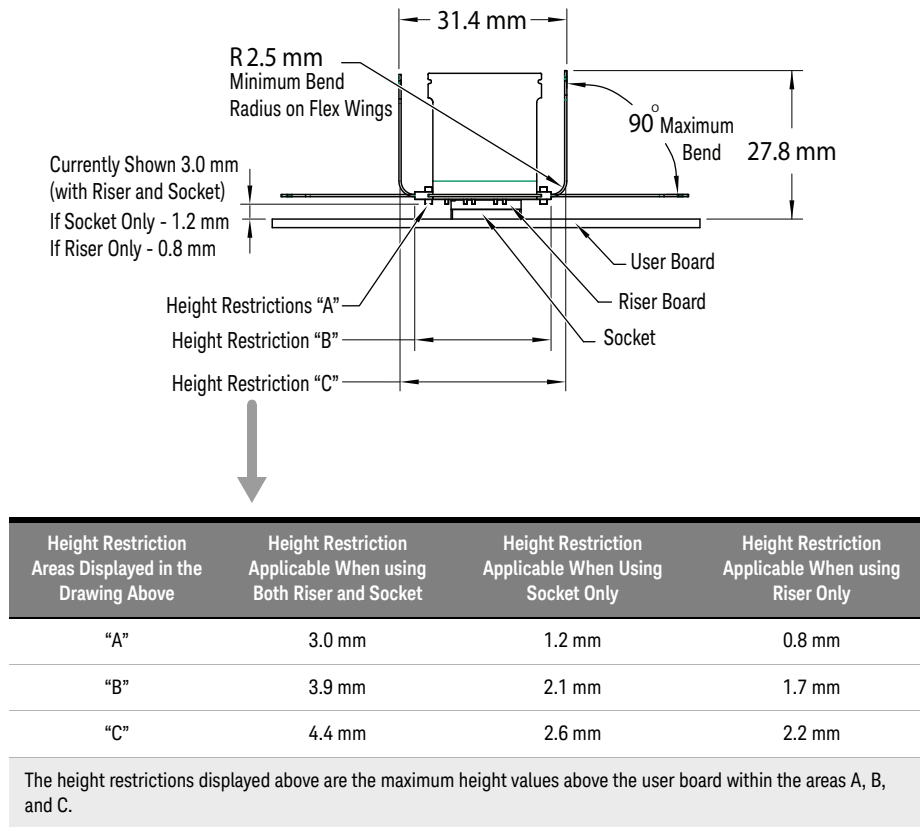
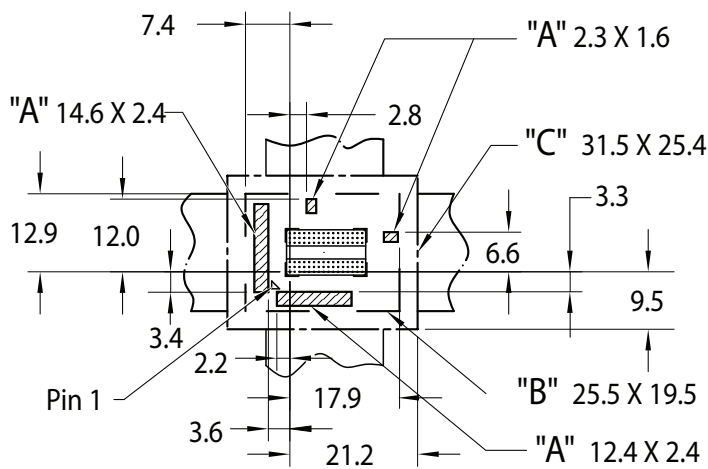

Figure 20 Bend Radius and Height Restrictions as Displayed in a Side View of a W4631A interposer with all the Components Mounted



NOTES:

- All dimensions are in millimeters (mm).
- "A", "B", "C" represent height restriction areas on the user board. Refer to the previous figure to visualize these Height Restrictions Areas A, B, and C in the side view of a mounted W4631A interposer.

Figure 21 KOV of a W4631A interposer (BOTTOM VIEW)

W4636A Interposer Dimensions

The following figure shows the dimensions of a W4636A DDR4 DRAM BGA interposer. All dimensions are in millimeters.

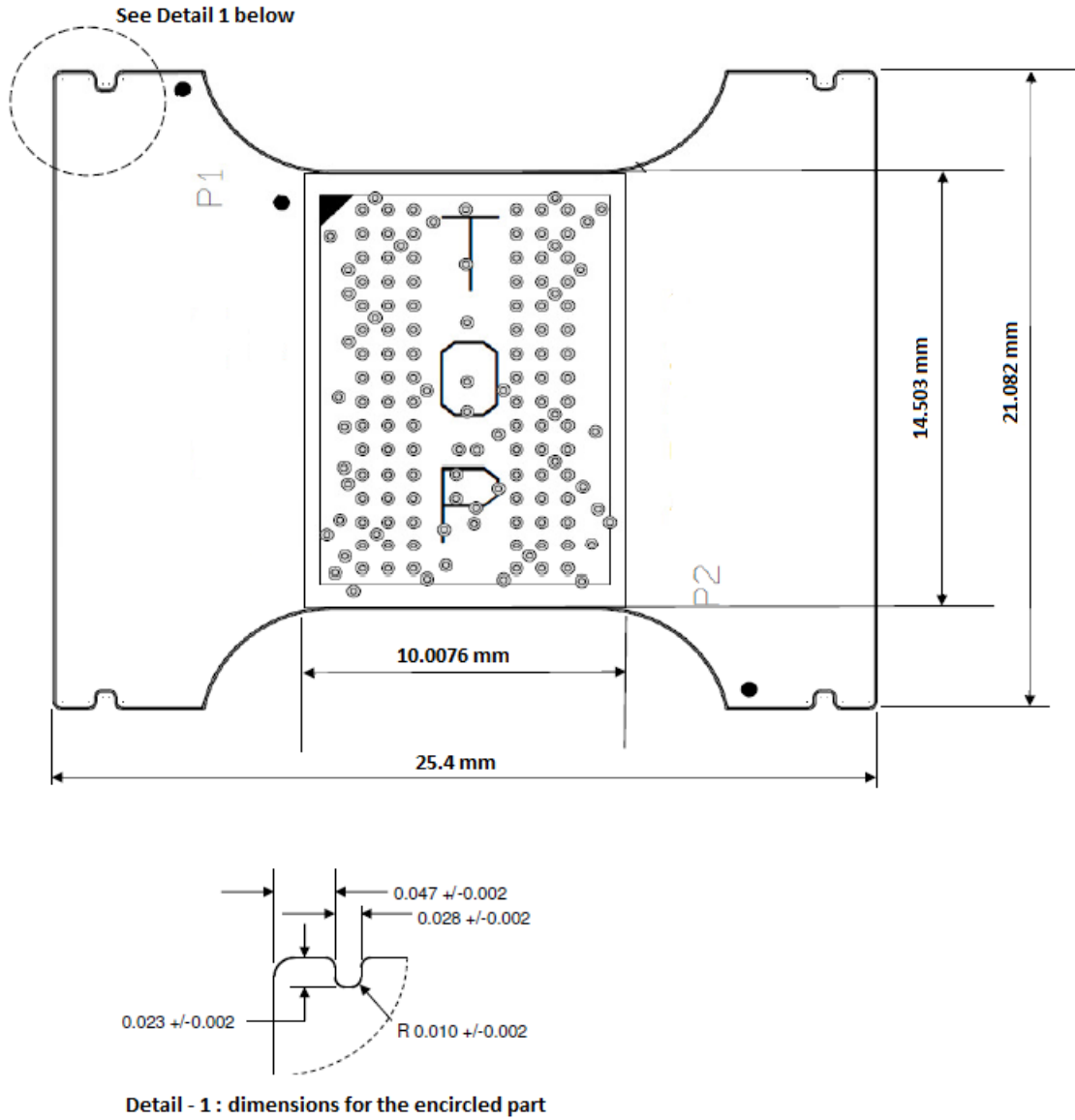
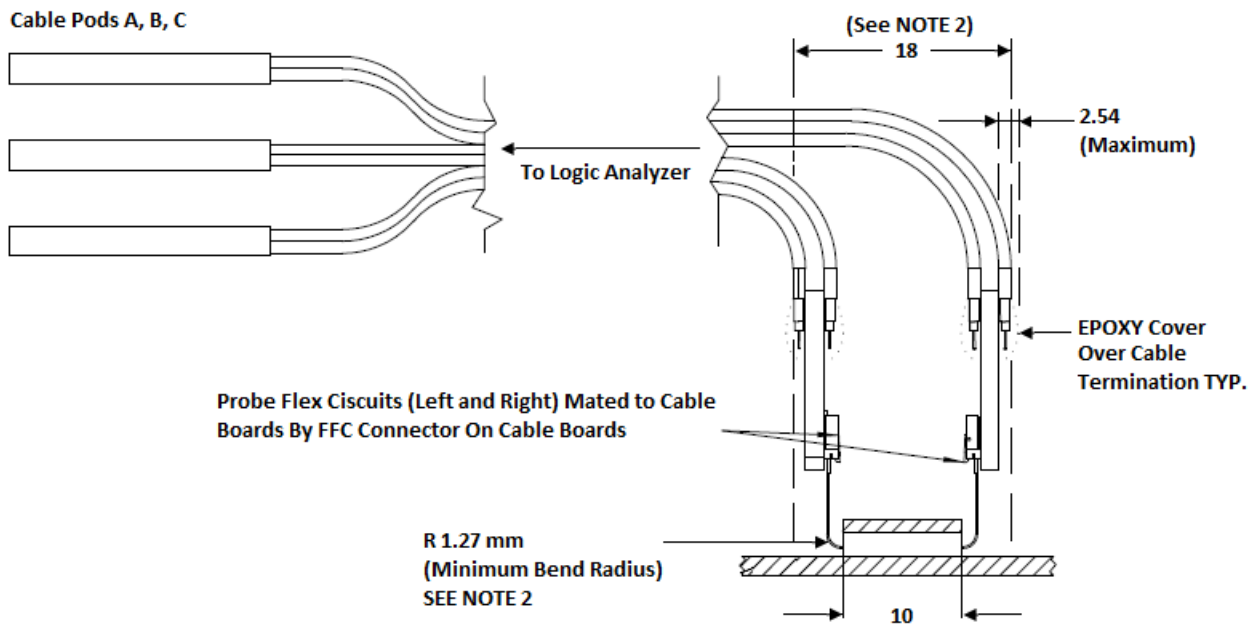
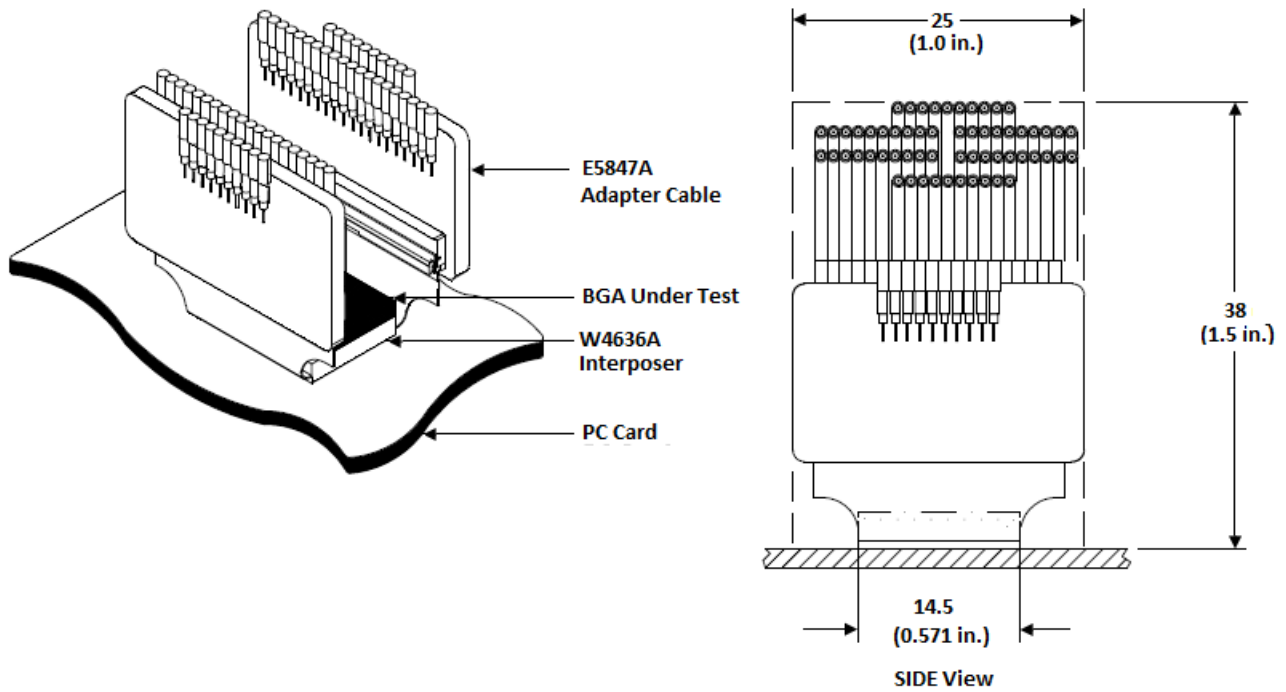

Figure 22 Dimensions of a W4636A interposer (TOP VIEW)

W4636A Keep-Out Volume

The following figure shows the KOV of an E5847A probe cable when connected to a W4636A interposer.



NOTES:

1. W4636A Probe and E5847A Adapter Cable require the X, Y, Z space depicted on this drawing.
2. KOV width dimension is specified per minimum recommended Bend radius of 1.27 mm. If flex is bent flat to rigid portion of the probe, KOV width would be 53 mm (2.10 inches).

Figure 23 KOV of a W4636A interposer with an E5847A cable

3 Introduction to W4640-Series Interposers

W4640-Series DDR4 BGA Interposers - Overview /	46
W4643A DDR4 x4/x8 BGA 2-Wings Interposer /	47
W4641A DDR4 x16 BGA 2-Wings Interposer /	49
U4208A 61-pin ZIF Probe / Cable (Connecting to Left Wing (P1) of W4641A/W4643A) /	51
U4209A 61-pin ZIF Probe / Cable (Connecting to Right Wing (P2) of W4641A/W4643A) /	52
Hardware and Software Requirements /	53
Mechanical Considerations /	55

This chapter introduces the hardware components that are needed for a W4640-series interposer setup. It also lists the software requirements as well as describes the mechanical considerations such as various dimensions and KOV that you should know before you start setting up and using these interposers.

W4640-Series DDR4 BGA Interposers - Overview

The W4640-series DDR4 DRAM BGA Interposers enable probing of embedded DDR4 DRAM (x4, x8, and x16) directly at the ball grid array using the Keysight U4164A logic analyzer. These interposers provide you:

- single touch probing of DQ and DM signals with separate RC networks
- higher data rate (greater than 3.2 Gb/s)
- smaller KOV

Using these interposers, you can capture DDR4 signals above 2.5Gb/s without double probe load.

A W4640-series interposer interposes between the DRAM being probed and the PC board where the DRAM would normally be soldered. The interposer is designed to be soldered to the PCB footprint for the DRAM on top of either the DDR4 riser included with the W4640 series BGA interposer or an optional Grypper socket (not included with the interposer) or both. The DRAM being probed is then soldered to the top side of the interposer.

Each DRAM signal in the common footprint passes directly from the bottom side of the interposer to the top side of the interposer. Buried probe resistors placed at the DRAM balls connect the probed signals to the rigid flex to mate with the U4208A/U4209A cables.

Currently, in this series, Keysight provides the following interposers:

- W4643A DDR4 x4/x8 BGA 2-Wings Interposer
- W4641A DDR4 x16 BGA 2-Wings Interposer

Compatibility with Logic Analyzer Modules

The W4640-series interposers are compatible with the Keysight U4164A AXIe-based logic analyzer module.

NOTE

All W4640A series interposers are tested for via connections through the interposer and signal trace connectivity to the wing connections.

W4643A DDR4 x4/x8 BGA 2-Wings Interposer

The W4643A interposer probes a 78-ball x4/x8 DDR4 DRAM. This interposer is optimized to work with the U4164A logic Analyzer module to achieve higher data rates with smaller KOV as compared to the W4630-series interposers.

This interposer effectively utilizes the single touch probing and quad sampling features of the U4164A logic analyzer module thereby allowing you to probe DDR4 DQ signals above 2.5Gb/s without double probe load. (In quad sampling, four samples are captured per clock edge at two different thresholds. Two samples are taken at each threshold.

The W4643A interposer has two flexible wings, each with a set of fingers for Zero Insertion Force (ZIF) connections that connect it to a U4208A or a U4209A 61-pin ZIF probe/cable. For the left wing of the interposer, you use the U4208A probe/cable and for the right wing of the interposer, you use the U4209A probe/cable. These cables are then connected to the U4164A Logic Analyzer module's pods.

The following figure shows a W4643A DDR4 BGA interposer's top view.

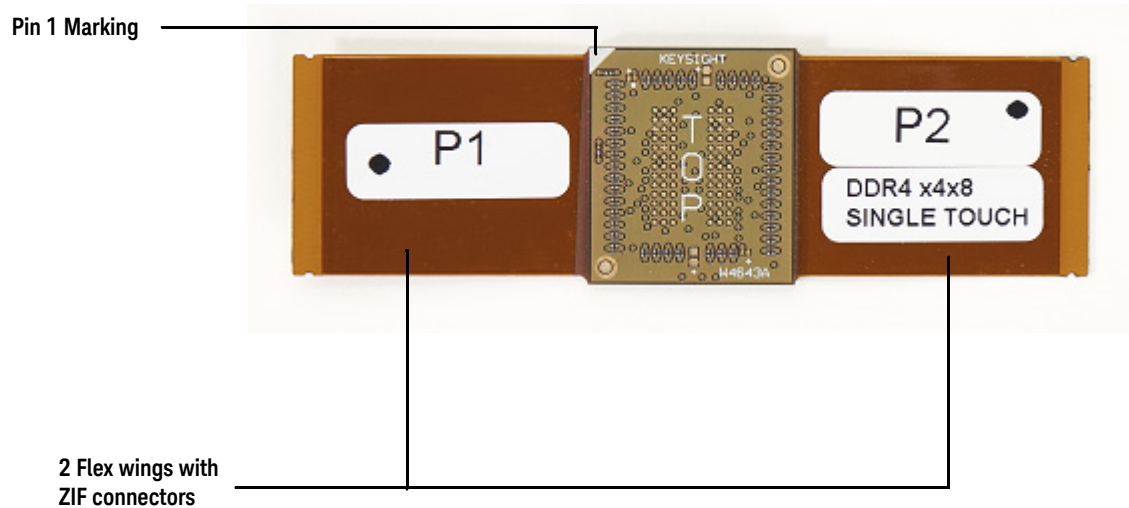

Figure 24 W4643A DDR4 x4/x8 BGA Interposer

W4643A Technical Features Summary

- Probes a 78-ball DDR4 single channel x4 or x8 DRAM chip. Maximum of 11 mm x 13 mm DDR4 DRAM package can fit on top of the W4643A interposer without an additional riser or a socket to provide clearance for the RC components.
- For the two flex wings of the interposer, the recommended bend radius is 1.27mm (0.05") if flex is bent at a rigid portion of the interposer.
- Logic analyzer connections are made using U4208A and U4209A ZIF probe cables. The U4208A/U4209A ZIF connectors doors open on the top of the W4643A wings and away from these wings.
- RC components network is present on the W4643A interposer. No RC network present on the U4208A/U4209A probe cables. Also, there are no RCs on the bottom of the interposer.

W4643A Riser and Optional Grypper Socket

A DDR4 78-ball riser is provided with each W4643A interposer to allow the interposer to clear surrounding devices. Optionally, you can use a Grypper socket. It is not provided with the interposer.

The following figure displays a riser that is provided with the W4643A interposer.

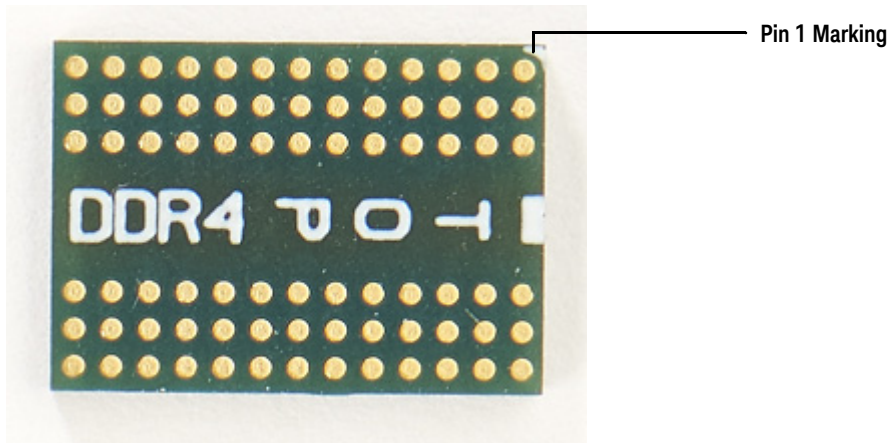

Figure 25 Riser that accompanies the W4643A interposer

NOTE

The DDR4 78-ball riser includes power and ground planes for optimal signal integrity. Due to the power and ground planes, the riser is only compatible with DDR4 78-ball DRAM.

To know how to solder the riser to the W4643A interposer and PC board, refer to the chapter ["Interposer and Riser Soldering Guidelines"](#) on page 61.

W4641A DDR4 x16 BGA 2-Wings Interposer

The W4641A interposer probes a 96-ball x16 DDR4 DRAM. This interposer is optimized to work with the U4164A logic Analyzer module to achieve higher data rates with smaller KOV as compared to the W4630-series interposers.

This interposer effectively utilizes the single touch probing and quad sampling features of the U4164A logic analyzer module thereby allowing you to probe DDR4 DQ signals above 2.5Gb/s without double probe load. (In quad sampling, four samples are captured per clock edge at two different thresholds. Two samples are taken at each threshold.)

The following figure shows a W4641A interposer's top side view.

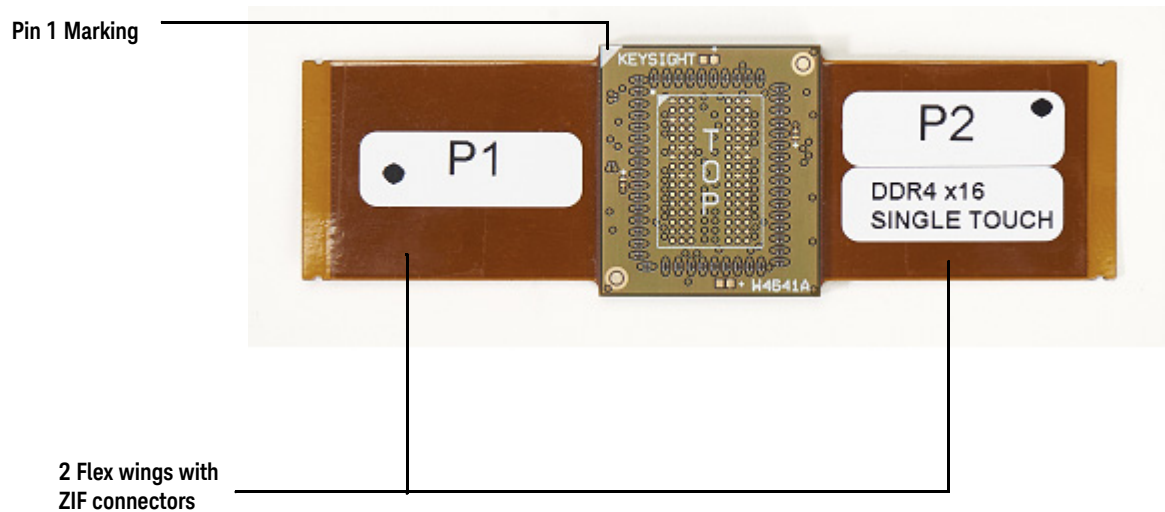

Figure 26 W4641A DDR4 x16 BGA 2-Wings Interposer

The W4641A interposer has two flexible wings, each with a set of fingers for Zero Insertion Force (ZIF) connections that connect it to a U4208A or a U4209A 61-pin ZIF probe/cable. For the left wing of the interposer, you use the U4208A probe/cable and for the right wing of the interposer, you use the U4209A probe/cable. These cables are then connected to the U4164A Logic Analyzer module's pods.

W4641A Technical Features Summary

- Probes a 96 ball DDR4 single channel x16 DRAM chip. Maximum of 10 mm x 14 mm DDR4 DRAM package can fit on top of the W4641A interposer.
- No RC network present on the U4208A/U4209A probe cables. RC network is present on the W4641A interposer. Also, there are no RCs on the bottom of the interposer.
- For the two flex wings of the interposer, the recommended minimum bend radius is 2.5 mm if flex is bent at a rigid portion of the interposer.
- Logic analyzer connections are made using U4208A and U4209A ZIF probe cables. The U4208A/U4209A ZIF connectors doors open on the top of the W4641A wings and away from these wings.

W4641A Riser and Optional Grypper Socket

A DDR4 96 ball riser is provided with each W4641A interposer to allow the interposer to clear surrounding devices. Optionally, you can use a Grypper socket. The following figure displays the riser that is provided with the W4641A interposer.

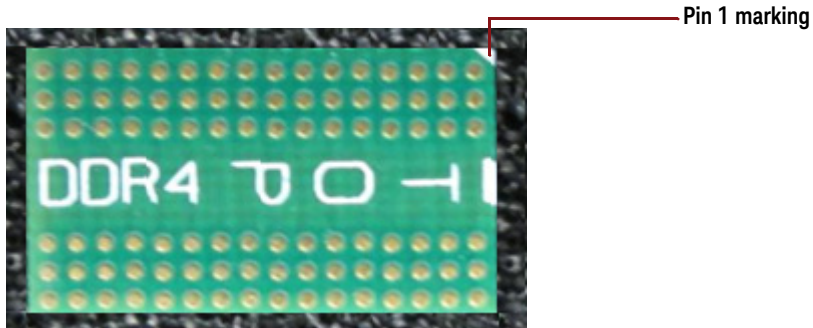

Figure 27 Riser that accompanies the W4641A interposer

CAUTION

The DDR4 96 balls riser includes power and ground planes for optimal signal integrity. Due to the power and ground planes, the riser is only compatible with DDR4 96 ball DRAM. Attaching this riser to a DDR3 target system can result in damaging the target system.

To know how to solder the riser to the W4641A interposer and PC board, refer to the chapter ["Interposer and Riser Soldering Guidelines"](#) on page 61.

U4208A 61-pin ZIF Probe / Cable (Connecting to Left Wing (P1) of W4641A/W4643A)

One U4208A probe cable is required to connect a W4641A or a W4643A interposer's left wing to a U4164A Logic Analyzer module.

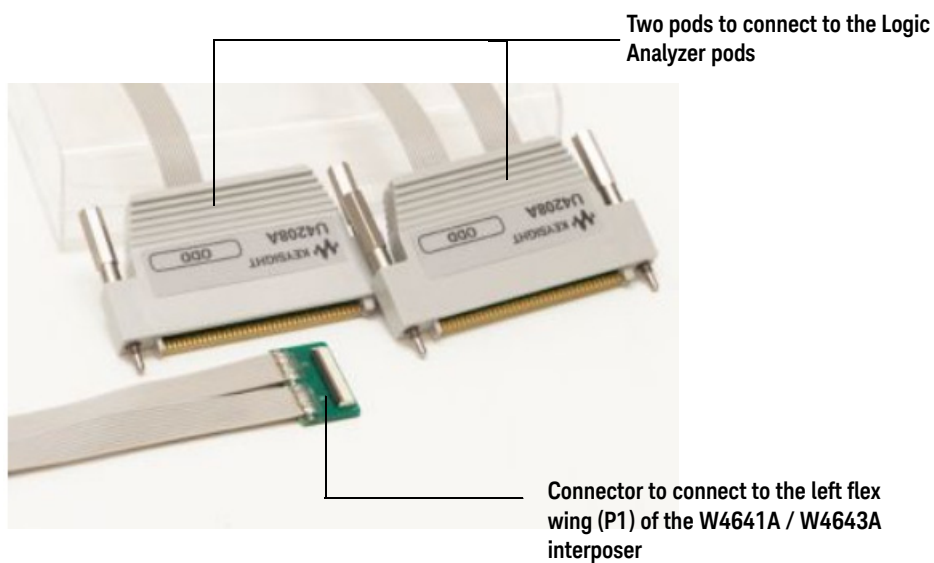

Figure 28 U4208A 61-pin ZIF probe cable

To know how to connect a W4641A or a W4643A interposer to a U4208A probe/cable, refer to the following topics in this guide:

- “Connecting the W4643A Interposer to U4208A and U4209A Probe Cables” on page 116
- “Connecting the W4641A Interposer to U4208A and U4209A Probe Cables” on page 126

To get information such as its characteristics, specifications, pinout, safety information, accessories, and dimensions of the U4208A probe/cable, refer to the *Keysight U4200A-Series Probes and Cables User Guide* (part number U4200-97000) available on www.keysight.com.

U4209A 61-pin ZIF Probe / Cable (Connecting to Right Wing (P2) of W4641A/W4643A)

One U4209A probe cable is required to connect a W4641A or a W4643A interposer's right wing to a U4164A Logic Analyzer module.

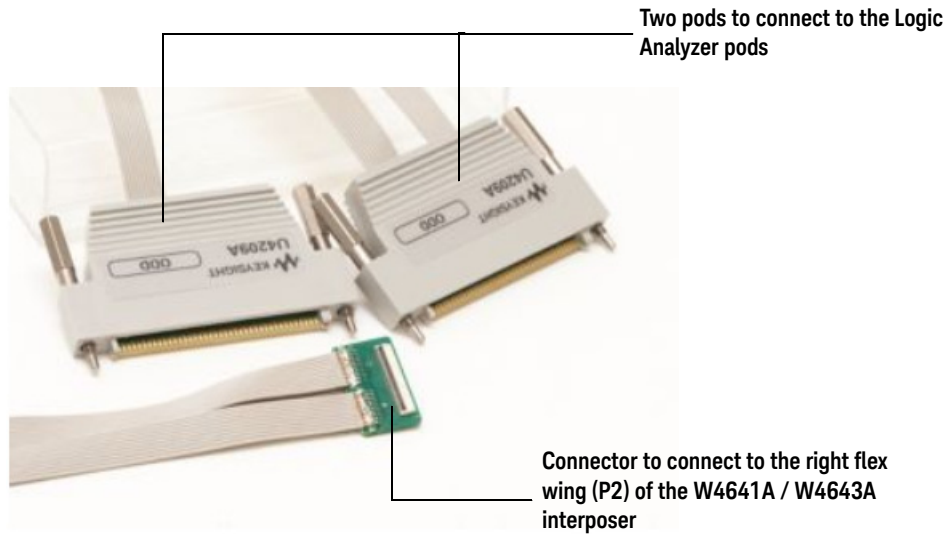

Figure 29 U4209A 61-pin ZIF probe cable

To know how to connect a W4641A or a W4643A interposer with a U4209A probe/cable, refer to the topics:

- “Connecting the W4643A Interposer to U4208A and U4209A Probe Cables” on page 116
- “Connecting the W4641A Interposer to U4208A and U4209A Probe Cables” on page 126

To get information such as its characteristics, specifications, pinout, safety information, accessories, and dimensions of the U4209A probe/cable, refer to the *Keysight U4200A-Series Probes and Cables User Guide* (part number U4200-97000) available on www.keysight.com.

Hardware and Software Requirements

Before you start installing the W4640-series probes, ensure that you have the following list of hardware and software components needed for these probes.

Hardware Requirements
U4164A AXIe-based Logic Analyzer Module (with option U4164A-02G speed grade)
M9502A 2-slot or M9505A 5-slot AXIe chassis to install the U4164A module
M9537A embedded controller or host PC with PCI express adapter card for the chassis
W4640A Series DDR4 BGA Interposer(s)
U4208A 61-pin ZIF probe cables to connect the W4641A or W4643A interposer to Logic Analyzer module One cable needed for each interposer
U4209A 61-pin ZIF probe cables to connect the W4641A or W4643A interposer to Logic Analyzer module One cable needed for each interposer

Software Requirements	Licensing	Description
Logic and Protocol Analyzer software (Mandatory)	Not Licensed	Base software platform for configuring and using Keysight's logic analyzer modules.
B4661A-1FP DDR 2/3/4 Bus Decoder software (Recommended)	Licensed	Allows you to decode and view transactions, commands, and data from a DDR2, DDR3, or DDR4 memory bus in your target system.
B4661A-3FP DDR 2/3/4 Protocol Compliance and Analysis toolset (Recommended)	Licensed	A set of tools to: <ul style="list-style-type: none"> evaluate and analyze the captured DDR data. perform real-time or post process compliance. set up a trigger on the specified address. graphically profile the distribution of memory accesses.
B4661A-4FP DDR 2/3/4 Memory Analysis Viewer (Recommended)	Licensed	A viewer installed and displayed within the Logic and Protocol Analyzer GUI to analyze: <ul style="list-style-type: none"> memory traffic statistics. refresh rate and self-refresh periods. distribution of memory accesses. performance measurements for data transfer rates and memory utilization.
DDR Setup Assistant and DDR Eyefinder software (Recommended)	Not Licensed	A wizard- like application that helps you set up your U4164A logic analyzer properly for DDR/LPDDR memory technologies State mode measurements for ADD/CMD/DATA capture and analysis.

NOTE

You can install the above-mentioned software components by downloading the latest versions of the required executables from the Keysight web site at: www.keysight.com/find/lpa-sw-download.

The following table displays the number of W4640-series BGA interposers and cables required to provide connections to channels of your logic analyzer module.

DRAM	Data Width	Access to	Number of Interposers	Number of ZIF Probes	Number of Logic Analyzer Modules
x4	x4	Command, Address, Control and Data	One W4643A	One U4208A for the left wing	One U4164A module
x8	x8			One U4209A for the right wing	
x16	x16	Command, Address, Control and Data	One W4641A	One U4208A for the left wing One U4209A for the right wing	One U4164A module for all supported data rates

Mechanical Considerations

W4643A Interposer Dimensions

The following figure shows the dimensions of a W4643A interposer.

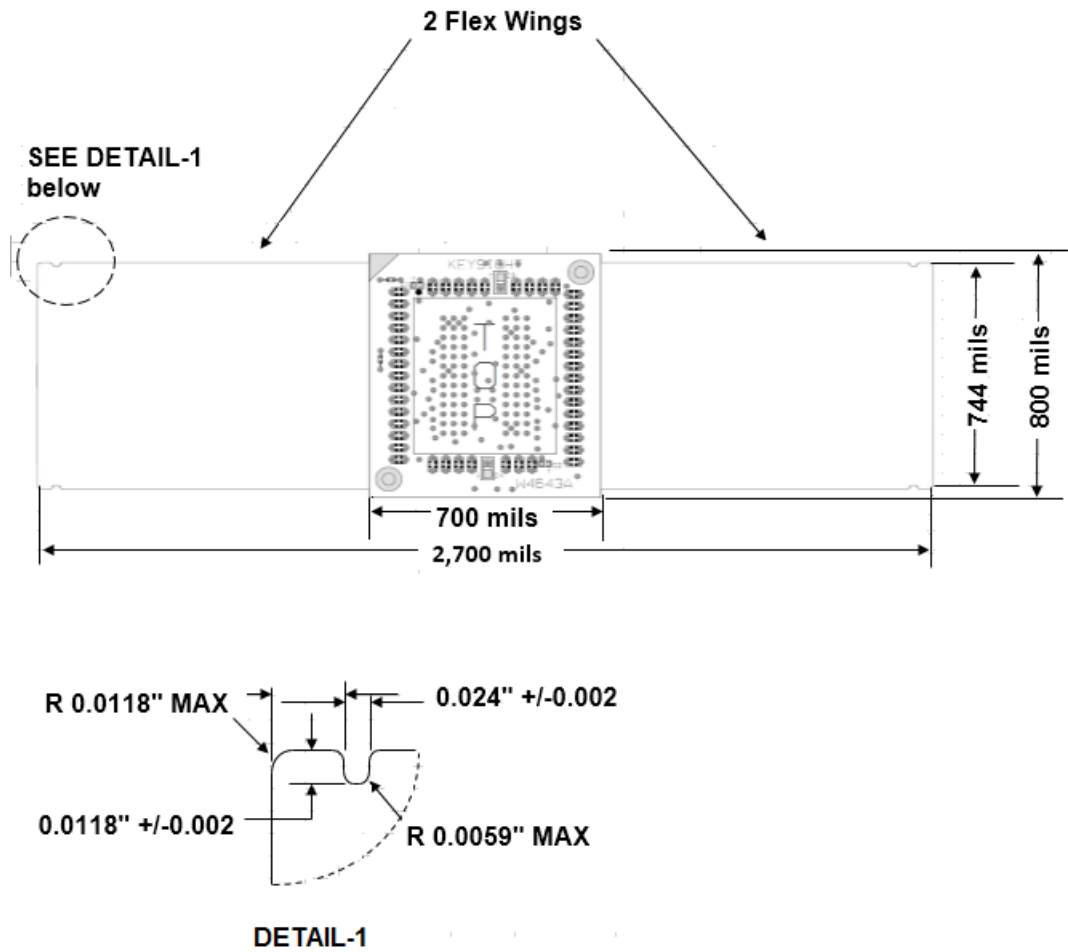
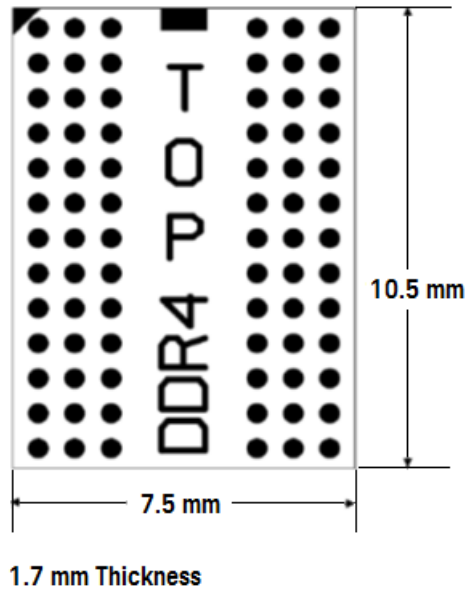

Figure 30 Dimensions of a W4643A interposer (TOP VIEW)

W4643A Riser Dimensions

All dimensions are in millimeters.



W4643A Keep-Out Volume

NOTE

You can install the W4643A interposer on a riser (shipped with the interposer) or a grypper socket to provide clearance to surrounding DRAM.

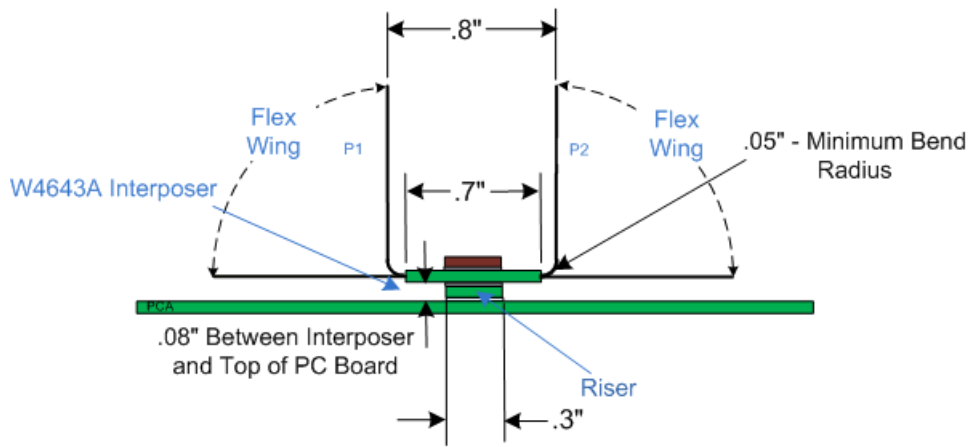

End View

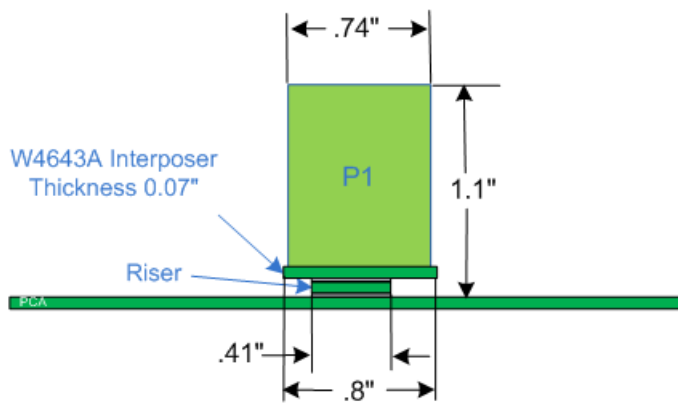

Side View

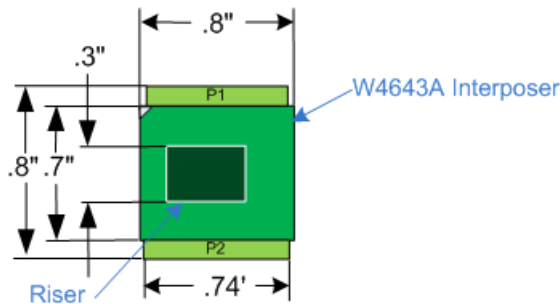

Bottom View

- Notes:**
- P1 and P2 are the Interposer Wings
 - All Dimensions are Nominal
 - There are no RCs on the bottom of the W4643A Interposer

Figure 31 KOV of a W4643A interposer

W4641A Interposer Dimensions

The following figure shows the dimensions of a W4641A interposer.

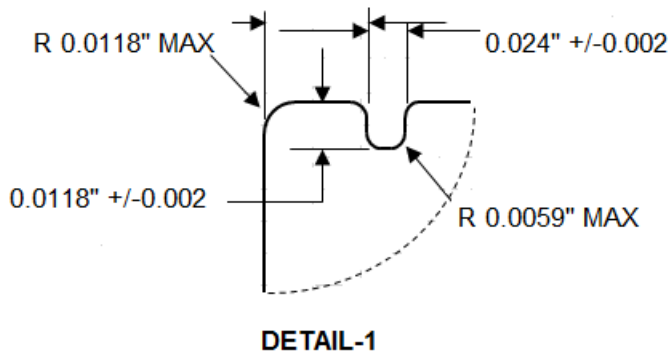
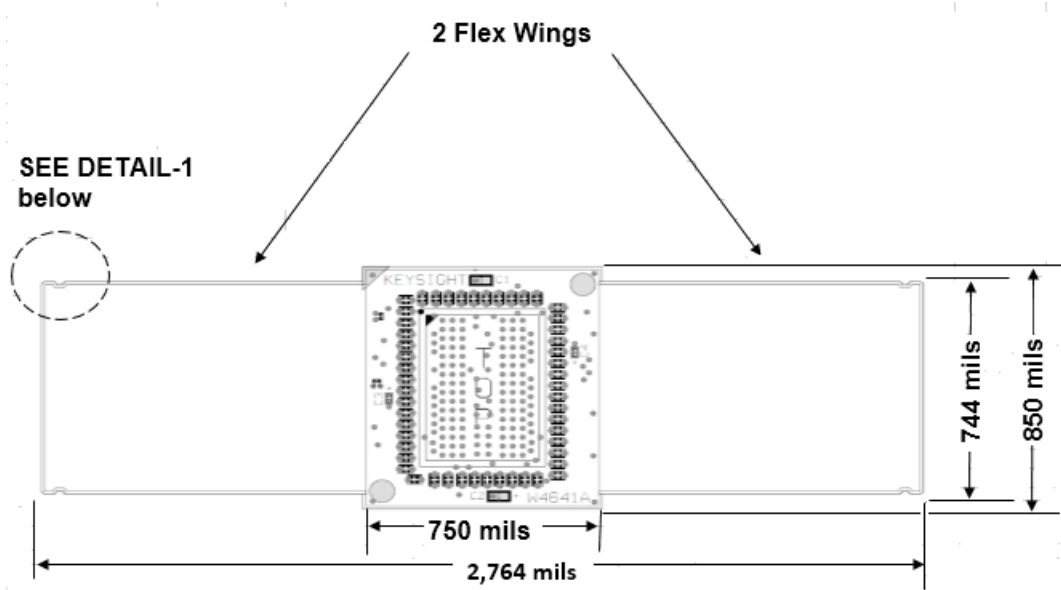
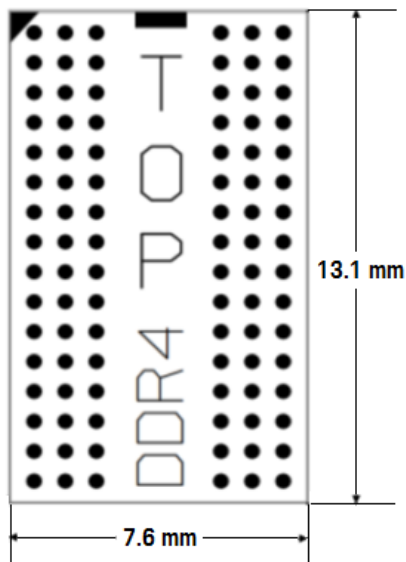

Figure 32 Dimensions of a W4641A interposer (TOP VIEW)

W4641A Riser Dimensions

All dimensions are in millimeters.



1.52 mm Thickness

W4641A Keep-Out Volume

NOTE

You can install the W4641A interposer on a riser (shipped with the interposer) or a grypper socket to provide clearance to surrounding DRAM.

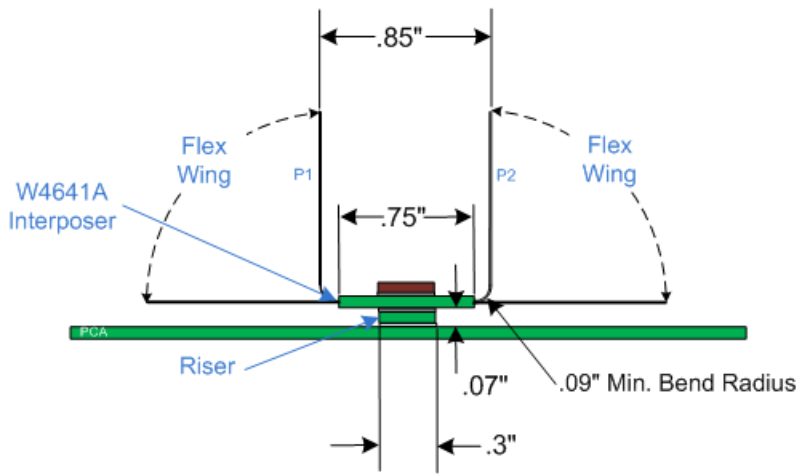

End View

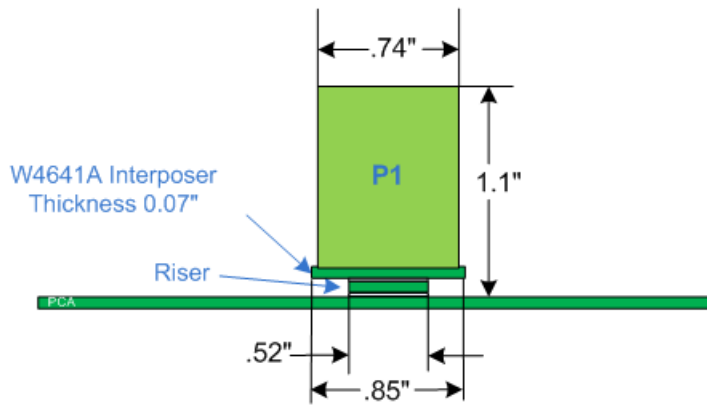

Side View

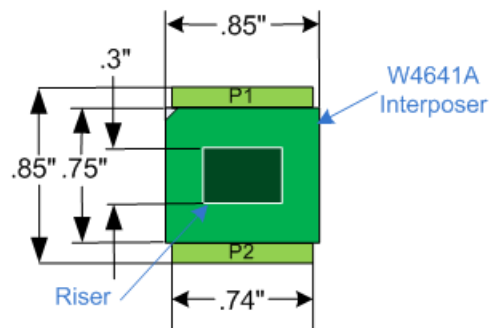

Bottom View

Note:

- P1 and P2 are the Interposer Wings
- All Dimensions are Nominal
- There are no RCs on the bottom of the W4641A interposer

Figure 33 KOV of a W4641A interposer

4 Interposer and Riser Soldering Guidelines

Recommended Soldering Guidelines / 63
Soldering Steps / 64
Interposer Fabrication Notes / 66

In this chapter, Keysight provides the soldering guidelines for the interposers described in this user's guide. However, Keysight cannot guarantee the successful interposer installation due to variations in processes and equipment used at individual BGA rework facilities.

Keysight recommends that interposers be installed by companies with specific expertise in this advanced type of processing.

Keysight does not endorse any specific BGA rework facility but recommends using a reputable and experienced BGA rework facility for the installation of BGA interposers. The following links are provided as a convenience to users investigating BGA rework facilities.

Information on BGA Rework Facilities

Circuit Technology Center
Haverhill, MA
USA

BGA Rework and Repair Services
<http://www.circuitrework.com/services/bga.shtml>

Keysight Technologies Adapter Rework
<http://www.circuitrework.com/features/671.shtml>

eTech
Round Rock, TX
www.eTech-WEB.com

Singularity Electronic Systems
Portsmouth, NH
www.singularitysys.com

Recommended Reading

BGA Component Rework Procedures
<http://www.circuitrework.com/guides/9-0.shtml>

BGA Component Rework Process Flow
<http://www.circuitrework.com/guides/9-1-1.shtml>

BGA Component Rework Inspection
<http://www.circuitrework.com/guides/9-1-2.shtml>

BGA Component Rework Profile Development, Standard Method
<http://www.circuitrework.com/guides/9-2-1.shtml>

Recommended Reading

BGA Component Rework Profile Development, Smart Track Method
<http://www.circuitrework.com/guides/9-2-2.shtml>

BGA Component Rework, Eutectic Solder Ball
<http://www.circuitrework.com/guides/9-3-1.shtml>

BGA Component Reballing, Fixture Method
<http://www.circuitrework.com/guides/9-4-1.shtml>

Recommended Soldering Guidelines

These guidelines are intended for anyone who has decided to install the winged BGA interposers themselves, or would like to provide guidelines to their regular contract manufacturer.

- These interposers are assembled using lead free or leaded soldering processes.
- Observe standard lead-free rework guidelines and processes when applying DDR5/DDR4 memory devices and attaching a riser to an interposer and DIMM.
- Typical time-above-liquidus (220°C in the case of SAC305 solder) is 30 to 90 seconds with 60 seconds as the good nominal target.
- The peak temperature at the SAC305 solder joints should be a minimum of 235°C.
- It is best to limit the peak temperature on the package of the IC at a maximum of 245°C.
- To minimize heating effects on components mounted on the interposer assembly, a leaded solder process can be used to attach a riser, when it is compatible with your prototype debug and validation methodologies.
- The flex wings on Keysight BGA interposers are made with Pylalux AP, the flex material, and Pylalux FR, the coverlay material with adhesive. Both of these materials have high moisture absorption characteristics, and always require baking prior to processing. Review the DuPont baking recommendation before processing.
- The maximum processing temperature that the W4630-series and W4640-series interposers can withstand is 260 °C for not more than 90 seconds. The maximum processing temperature that the W5643A interposer can withstand is 250 °C for not more than 150 seconds.
- These interposers are supplied without solder balls. Depending on the exact attachment order, either leaded or lead-free solder may be preferred to attach the interposer to the DUT. The design of the interposer supports either choice.
- The flexible “wings” on the interposer may need to be bent upwards before soldering to avoid mechanical contact with components adjacent to the interposer on the DUT. If interposer wings are bent during the soldering process, precautions must be taken to ensure that the wings do not move during the process. Applying heat to a bent wing has the tendency to cause the wing to relax and this can result in movement during the soldering process that can damage the integrity of the solder joints.

Soldering Steps

These steps and guidelines apply only to the proper method of attaching BGA interposers to their target host boards. These do not attempt to provide instructions on how to attach BGA balls to the interposer, nor do these attempt to suggest a flux or a solder paste process.

- 1 Profile Development
 - a Profile must conform to the solder paste specification. Use the lowest possible temperatures that will insure reflow.
 - b Profile must also provide a slow ramp up to temperature.
 - c It is recommended that the profile be developed using a non-functional sample interposer in a location on a sample target that is similar to the actual target.
 - d The highest processing temperature must be in the range of 240 °C to 260 °C for the W4630/40-series interposers and up to 250 °C for the W5643A interposer. The maximum processing time at the highest temperature must not exceed 90 seconds for the W4630/40-series interposers and 150 seconds for the W5643A interposer.
- 2 Material Baking
 - a Prior to soldering, bake interposer (to eliminate moisture) for 2-10 hours at 250° F (121° C).
 - b Shield flex areas.
 - c Polyimide films absorb moisture quickly; therefore, soldering and reflow should be done within 30 minutes after baking.
 - d A 7 or 9 zone conventional oven is beneficial. A conventional oven is preferred over infra-red.
 - e Vacuum ovens are also used to remove water. Lower temperatures, such as 150-175 F (65-80 C) can be used. This method also reduces the oxidation of the exposed copper pads.
 - f After baking, if the units are not reflowed within a few hours, these should be re-baked or placed in a desiccant chamber.
- 3 Heat Shielding
 - a Kapton tape is applied to the bottom-side covering the gold contact area and wrapping around the outside edge to the top-side.
 - b Three layers of Kapton tape are applied to the top-side covering the entire wing extending over to the rigid board.
 - c Additional insulating of the wing area is done by applying a thick coating of the high temperature peelable masking to the Kapton tape covering the entire area to reduce the exposure to the hot gas heat cycle.
- 4 Host assembly components must be shielded using Kapton tape, aluminum heat shield blanket, or plates.
- 5 Site Preparation
 - a If the interposer is being installed onto a new board with gold pads, these pads should be pre-tin to ensure the pads wet properly, and to lower the chance of oxidation.
 - b Add solder paste to the target board using a mini-stencil. This is recommended over using flux only.
- 6 Interposer Reflow
 - a Use the lowest possible temp for reflow - Use a slow ramp up to temperature.
 - b Aim the shielded wings of the interposer upwards. The minimum bend radius must be 1.27mm (0.05 In) to insure that the copper foil does not fracture.
 - c Place the interposer using vision equipped BGA placement/reflow system such as an SRT.
 - d Reflow per the prepared heating profile.
- 7 Memory placement
 - a Add staking epoxy to the four corners of the placed interposer, and cure at 150°C for 2 minutes. This time is defined from the moment the adhesive reaches the cure temperature. As

a convenience, the following link has been supplied on a staking adhesive.

[https://tds.us.henkel.com/NA/UT/HNAUTTDS.nsf/web/7DA17BAB270FA76E88257187000D6EE/\\$File/3609-EN.pdf](https://tds.us.henkel.com/NA/UT/HNAUTTDS.nsf/web/7DA17BAB270FA76E88257187000D6EE/$File/3609-EN.pdf)

- b* Apply solder paste to the top-side of interposer.
 - c* Position memory using an SRT (or equivalent) with vision system for manual placement.
 - d* Reflow per the prepared heating profile.
- 8 Post Processing
- a* Remove flux residue.
 - b* Remove any Kapton tape heat shielding and peelable mask material.
 - c* Remove heat shielding from the target board.

Interposer Fabrication Notes

Operating Environment

The W5643A and W4630/40-series interposers are constructed of polyimide material that supports solder attachment of the interposer using the higher temperatures required by a lead-free solder process. The coefficient of thermal expansion for the interposer is 55 ppm/degree C. When operating in a soldered-down environment over a wide range of temperatures, the expansion coefficient of the interposer, DRAM, and system being probed must be matched to avoid stress related failure of the solder connections between the Interposer and attached components. The interposer material allows operation over an industrial temperature range of -40 to +85 degrees Celsius (non-condensing), subject to the above constraint.

Mechanical Dimensions

When the BGA interposer is soldered to a riser, flatness must be maintained on the order of 3.5 mils or less across the BGA footprint to maximize successful soldering to the interposer.

5 Setting up the W5643A Interposer

W5643A Interposer Setup - Overview / 68

Step 1 - Soldering the W5643A Interposer and Riser / 69

Step 2 - Connecting the W5643A Interposer to U4208A and U4209A Probe Cables / 70

Step 3 - Connecting the U4208A and U4209A Probe Cables to a U4164A Logic Analyzer / 72

W5643A Interposer Wings Pinout / 73

Logic Analyzer Channels to Signals Mapping / 75

W5643A Interposer Setup - Overview

- 1 Solder the riser, interposer, and memory components. (See [page 69](#))
- 2 Connect the interposer flex wings to U4208A and U4209A probe cables. (See [page 70](#))
- 3 Connect the U4208A and U4209A probe cables to a U4164A Logic Analyzer module's pods. (See [page 72](#))

CAUTION

Use ESD precautions. Electrostatic discharge can damage components on your board or in the interposer. Use a grounded wrist strap and other ESD control measures as appropriate.

NOTE

Do not open the vacuum sealed packs of the W5643A interposer until you are ready to install the interposer. Discard these packs once the package is opened.

WARNING

You should exercise caution when using the sharp alignment and connector pins for the interposer and cable to avoid personal injury.

Step 1 - Soldering the W5643A Interposer and Riser

If there is sufficient KOV, the W5643A interposer can be soldered directly to the DRAM PCB footprint.

However, for clearance issues, the W5643A interposer can be attached to the DRAM PCB footprint with:

- either the riser soldered in between the interposer and PC board.
- or an optional Grypper socket (not included with the interposer) installed in between the interposer and PC board.

The DRAM is soldered to the top side of the interposer. The stack up of these soldered components is illustrated in the following figure.

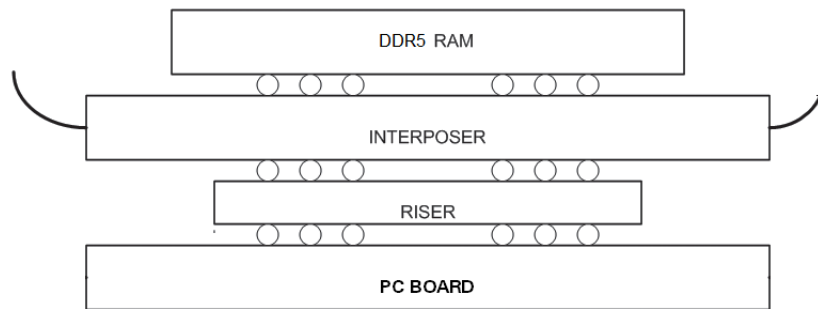

Figure 34 PC board, riser (or optional Grypper socket), interposer, and DRAM stack up

NOTE

A maximum of 9 mm x 12 mm DDR5 DRAM package can fit on top of the W5643A interposer without an additional riser or a socket on the top of the interposer and under DRAM.

DDR5 DRAM packages may cover the surface mount components on the W5643A that surround the DRAM outline. This is allowed as long as there is clearance.

See [page 18](#) for mechanical considerations.

Refer to the chapter "[Interposer and Riser Soldering Guidelines](#)" on page 61.

Step 2 - Connecting the W5643A Interposer to U4208A and U4209A Probe Cables

After soldering the components or installing with a Grypper socket, you can start connecting the W5643A interposer to the U4208A and U4209A probe cables.

Labeling the Probe Cables

The U4208A and U4209A cables ship with pod labels unattached. Use the sheet of labels included with the cable shipment to correctly label pods as displayed in the following picture.

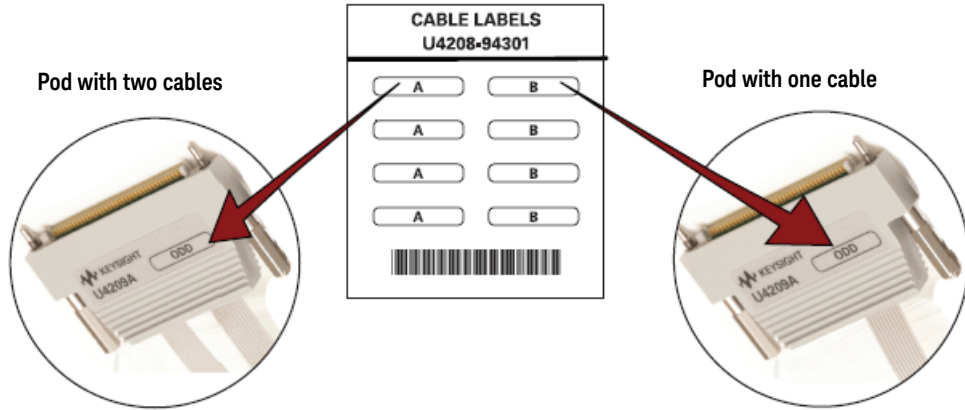

W5643A Interposer and U4208A / U4209A Probe Cable Connection and Orientation

As illustrated in the photo below, you need to connect:

- the U4208A probe cable to the right wing (P2) of the interposer.
- the U4209A probe cable to the left wing (P1) of the interposer.

When making these connections, the orientation of these cables and interposer should be as shown in the following photo to ensure proper connection for DDR5 signals.

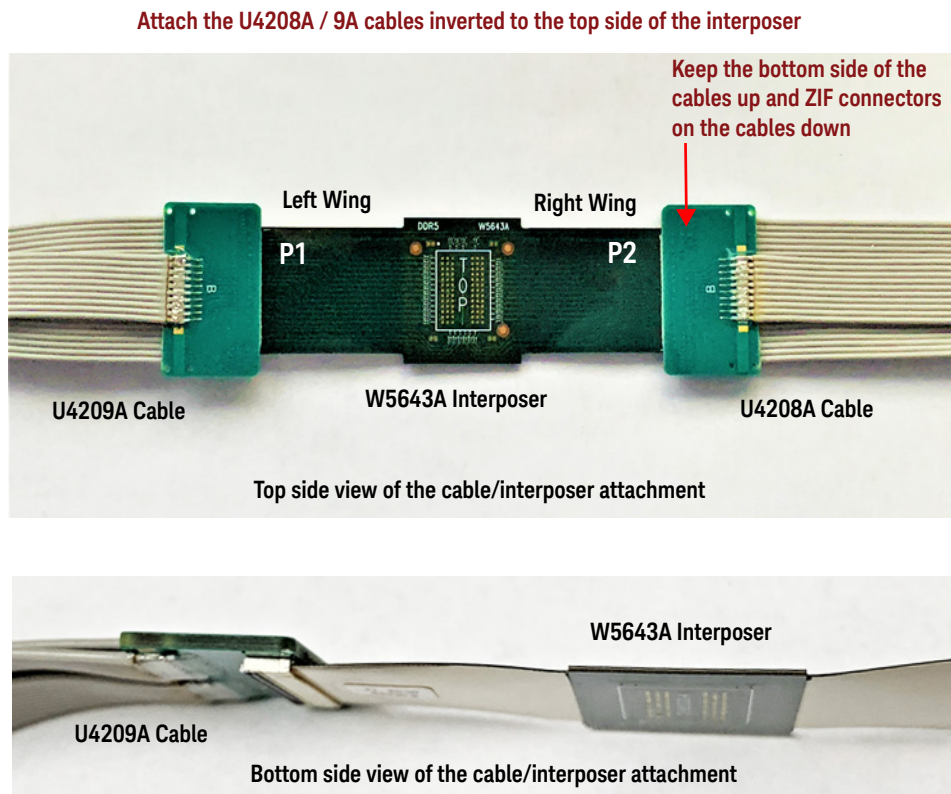

Figure 35 W5643A Interposer and U4208A / U4209A Probe Cables Connection and Orientation

To attach a U4208A or a U4209A ZIF connector to a flex wing of the W5643A interposer, perform the following steps.

- 1 Angle the flex wing of the interposer into the probe cable's ZIF connector.
- 2 Align the probe cable's ZIF connector tabs with interposer's wing notches.
- 3 Shut the ZIF door.
- 4 Ensure that the wings of the interposer are properly latched to the ZIF connectors on the U4208A and U4209A probe cables.

Step 3 - Connecting the U4208A and U4209A Probe Cables to a U4164A Logic Analyzer

In a W5643A interposer setup, you connect the U4208A and U4209A probe cable pods to U4164A logic analyzer pods as per the mapping shown in the table below. *(Even pods of the logic analyzer modules are NOT used.)*

Probe Cable Pods	U4164A Logic Analyzer Pods
U4208A Cable Pods	
Pod A	Pod 1 Signals are in Master clock (single-sampled) on this pod
Pod B	Pod 7 Signals are quad-sampled on this pod
U4209A Cable Pods	
Pod A	Pod 3 Signals are in Master clock (single-sampled) on this pod
Pod B	Pod 5 Signals are quad-sampled on this pod

The mapping of the U4208A and U4209A probe cable pods and logic analyzer pods is also illustrated with the help of the following diagram.

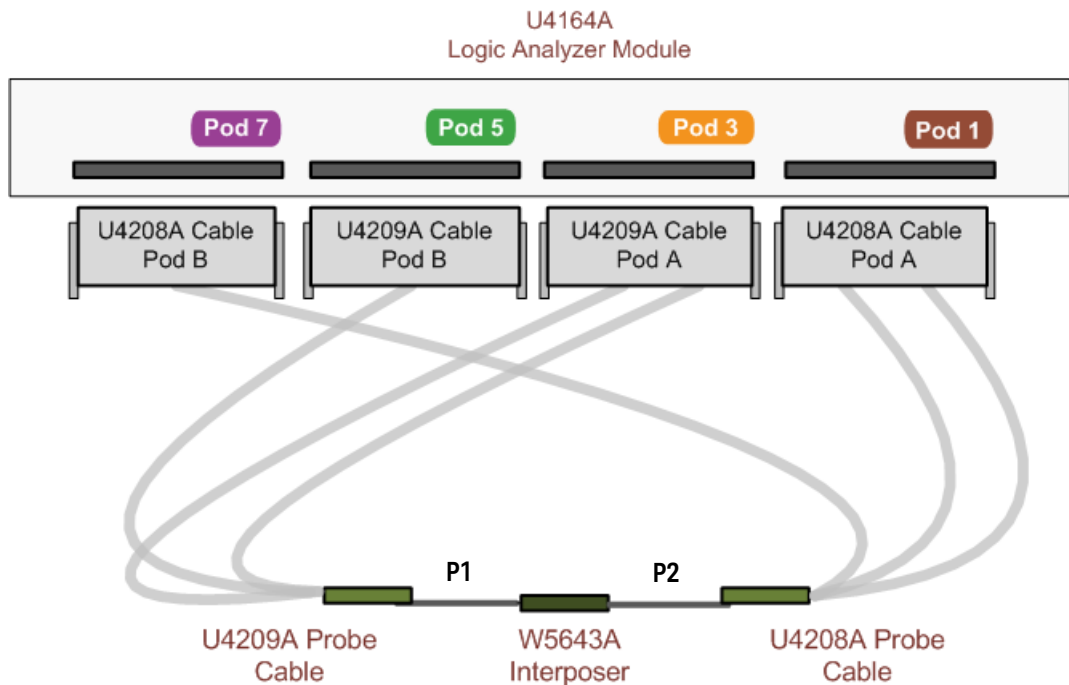

Figure 36 Connections between U4208A and U4209A probe cables and Logic Analyzer pods

W5643A Interposer Wings Pinout

The following table lists the pinout of the two wings of the W5643A interposer. The table includes the signals being probed when using the interposer in Master Clock mode or Quad Sampling mode (supported by the U4164A logic analyzer module).

In this table,





- Clock/Qualifier inputs are highlighted with yellow 
- Quad-sampled signals are highlighted with green 
- Single-sampled signals are highlighted with blue 
- Table cells marked with  indicate pins that are not accessible.

Table 1 W5643A Interposer Wings Pinout

Pin	W5643A Interposer Wings	
	Left Wing (P1)	Right Wing (P2)
2	DQS_t	
4	DQ2	
6	LBDQ	
8	DQ0	CA3
10		
12		
14	DQS_c	CA13
16	DQ6	CA9
18	DQ4	RESET_n
20		CA11
22	CA_ODT	CA7
24	CS_n	CA5
26	ALERT_n	
28	CA0	CA1
30		CK_c
32		CK_t
34	CA4	
36	CA6	
38		
40		
42	CAI	DQ5
44	CA10	DQ7
46		DQ1
Pin	U4209A	U4208A

Pin	W5643A Interposer Wings	
	Left Wing (P1)	Right Wing (P2)
48	CA8	DM_n
50		
52		
54	CA12	LBDQS
56	CA2	DQ3
58		
60		MIR
Pin	U4209A	U4208A

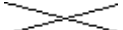
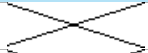
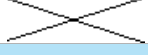
Logic Analyzer Channels to Signals Mapping

When you connect the U4208A and U4209A probe cables to a U4164A Logic Analyzer as per the connection diagram in [Figure 36](#), the logic analyzer channels are mapped to DDR5 signals as per the table displayed below.

These signals are automatically configured when you load one of the configuration files supplied with the Keysight B4661A decoder software.

NOTE

Clock inputs for each logic analyzer pod are highlighted with yellow in this table.

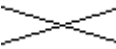















Table cells marked with  indicate logic analyzer channels that are not accessible.

Table 2 Signals and Logic Analyzer Channels Mapping when using the W5643A Interposer

Logic Analyzer Pod and its Channels		Signals from U4208A Pod A	Logic Analyzer Pod and its Channels		Signals from U4209A Pod A	Logic Analyzer Pod and its Channels		Signals from U4209A Pod B	Logic Analyzer Pod and its Channels		Signals from U4208A Pod B
Pod 1 <i>(Dual sampled)</i>	0		Pod 3 <i>(Dual sampled)</i>	0		Pod 5 <i>(Quad sampled)</i>	0		Pod 7 <i>(Quad sampled)</i>	0	DQ5
	1			1			1			1	
	2			2	CA2		2	DQ4		2	DQ7
	3	CA3		3	CA12		3			3	
	4	CA13		4	CA8		4	DQ6		4	DQ1
	5	CA9		5			5			5	
	6	RESET_n		6	CA10		6	DQS_c		6	DM_n
	7	CA11		7	CAI		7			7	
	8	CA7		8			8	DQ0		8	LBDQS
	9	CA5		9			9			9	
	10			10	CA6		10	LBDQ		10	DQ3
	11	CA1		11	CA4		11			11	
	12			12	CA0		12	DQ2		12	
	13			13	ALERT_n		13			13	
	14			14	CS_n		14	DQS_t		14	MIR
	15			15	CA_ODT		15			15	
	CLK	CK_c		CLK			CLK			CLK	
	CLK#	CK_t		CLK#			CLK#			CLK#	

6 Setting up the W4633A Interposer

W4633A Interposer Setup - Overview / 78
Soldering the W4633A Interposer and Riser / 79
Connecting the W4633A Interposer to E5849A Probe Cables / 80
Connecting the E5849A Probe Cables to a Logic Analyzer / 84

W4633A Interposer Setup - Overview

- 1 Solder the riser, interposer, and memory components. (See [page 79](#))
- 2 Connect the interposer flex wings to E5849A probe cables. (See [page 80](#))
- 3 Connect the E5849A probe cables to a U4154A Logic Analyzer module's pods via U4201A logic analyzer cables. (See [page 84](#))

CAUTION

Use ESD precautions. Electrostatic discharge can damage components on your board or in the interposer. Use a grounded wrist strap and other ESD control measures as appropriate.

NOTE

Do not open the vacuum sealed packs of the W4633A interposer until you are ready to install the interposer. Discard these packs once the package is opened.

Soldering the W4633A Interposer and Riser

The W4633A interposer needs to be attached to the DRAM PCB footprint on the design to be probed with either the riser soldered or an optional Grypper socket (not included with the interposer) installed in between the interposer and PC board. The desired DRAM is soldered to the top side of the interposer. The stack up of these soldered components is illustrated in the following figure.

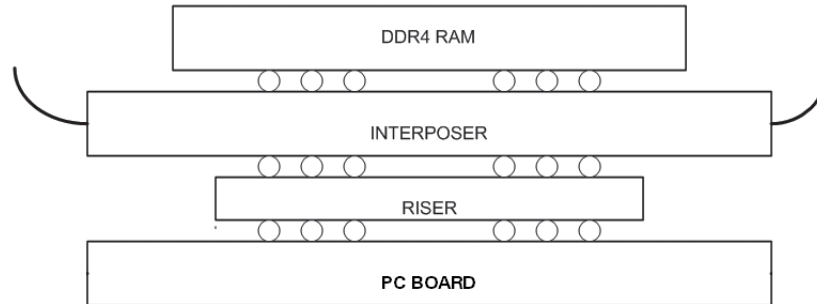

Figure 37 PC board, riser (or optional Grypper socket), interposer, and DRAM stack up

NOTE

A maximum of 11 mm x 14 mm DDR4 DRAM package can fit on top of the W4633A interposer without an additional riser or a socket on the top of the interposer and under DRAM.

Refer to the chapter "[Interposer and Riser Soldering Guidelines](#)" on page 61.

Connecting the W4633A Interposer to E5849A Probe Cables

After soldering the components or installing with a Grypper socket, you can start connecting the W4633A interposer to the E5849A probe cables.

NOTE

Please handle the interposer with care and ensure that the wings on the W4633A interposer are properly latched to the ZIF connectors on the E5849A probe cables.

E5849A cables ship with labels unattached. Use the sheet of labels included with the E5949A to label one as "Cable 1" and a second as "Cable 2".

The following diagram illustrates how the interposer and E5849A cables have to be connected. As illustrated in this diagram:

- Two E5849A cables, *Cable 1* and *Cable 2* are used for a single W4633A interposer.
- The left and right wings of *Cable 1* connect to P1-Data and P2-Address/Command wings respectively of the interposer.
- The right wing of *Cable 2* connects to P3-Address/Command wing of the interposer while the left wing of *Cable 2* has not been used and left unconnected.

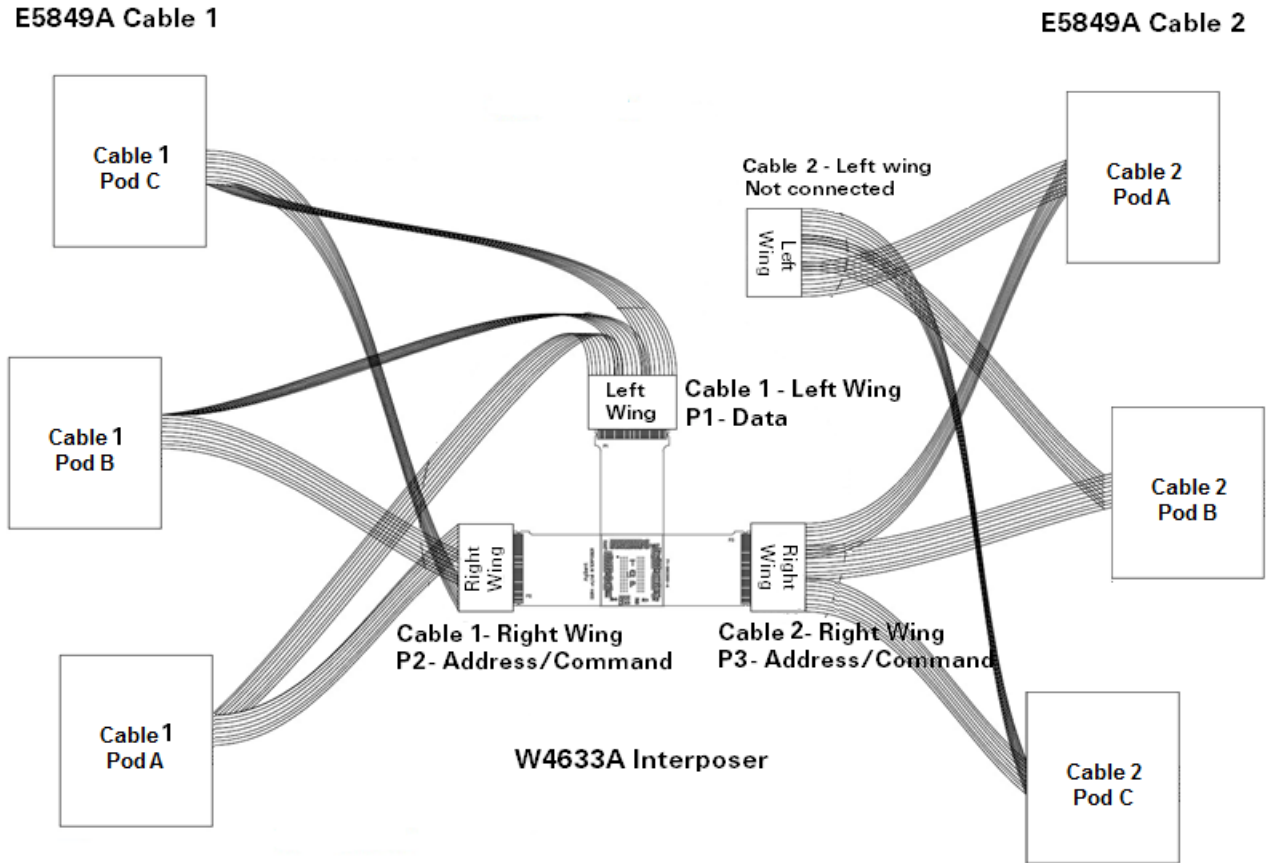

Figure 38 W4633A Interposer and E5849A Cable Connections

ZIF connectors on the E5849A cable connect to the bottom side of the flex wings on the W4633A interposer. ZIF doors close on the ground side of the flex wings. The following picture displays a W4633A interposer with E5849A ZIF connectors attached to its flex wings.

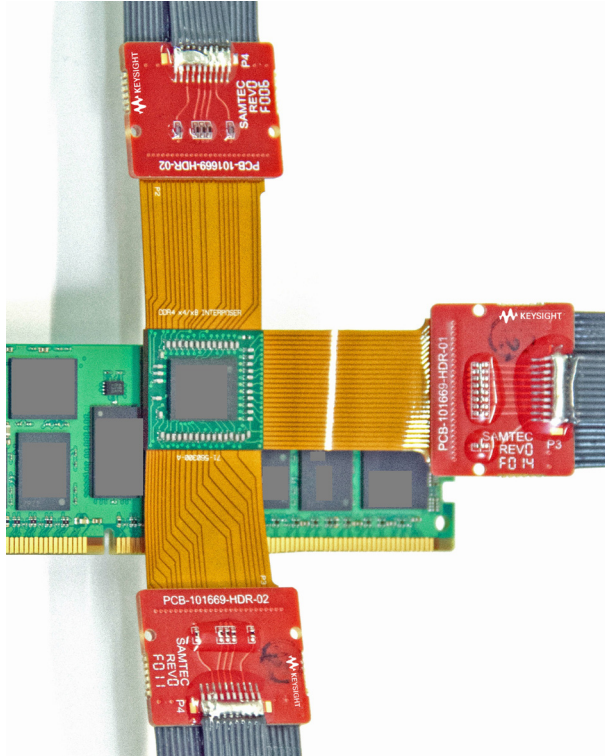
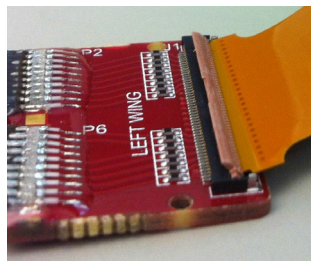

Figure 39 W4633A interposer attached to E5849A ZIF connectors

To attach an E5849A ZIF connector to a flex wing of the W4633A interposer, perform the following three steps.

- 1 Angle the flex wing of the interposer into an E5849A ZIF connector. GND towards door closure.



- 2 Align the E5849A ZIF connector tabs with interposer's wing notches.



- 3 Shut the ZIF door.

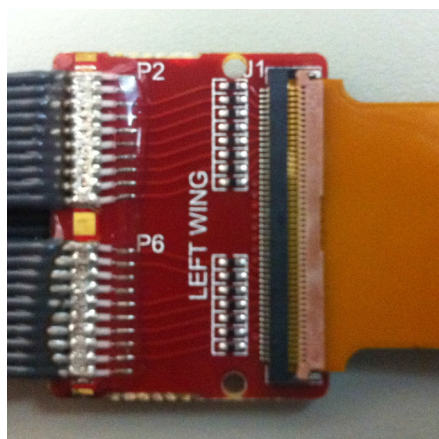

W4633A Interposer Wings Pinout

The following table lists the pinout of the three wings of a W4633A interposer.

Note: Clock inputs are highlighted with yellow in this table.

Table 3 W4633A Interposer Wings Pinout

Pin	W4633A Interposer Wings		
	J1 - DATA	J2 - ADDRESS/COMMAND	J3 - ADDRESS/COMMAND
2	DQ4_2	A2	
4	DQ4_1	PAR	CS#
6	DQ0_2		C1
8	DQ0_1	A0	CAS#
10	TDQS#_2	A11	RAS#
12	TDQS#_1	A8	A12
14	DQS#_2	A6	
16	DQS#_1	BA0	BG1
18	DQS_2	A4	A3
20	DQS_1	RST#	
22	DQ2_2		
24	DQ2_1	PULLDN	
26	DQ6_2	CKE	
28	DQ6_1		BA1
30	DQ7_2		ALERT#
32	DQ7_1	BG0	A5
Pin	E5849A Cable 1 Left Wing Connector	E5849A Cable 1 Right Wing Connector	E5849A Cable 2 Right Wing Connector

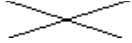
Pin	W4633A Interposer Wings		
	J1 - DATA	J2 - ADDRESS/COMMAND	J3 - ADDRESS/COMMAND
34	DQ3_2	A10	A7
36	DQ3_1	WE#	
38	DQ1_2	ACT#	A1
40	DQ1_1	C0	A13
42	DM#_2		CK
44	DM#_1		CK#
46	DQS_2	C2	A17
48	DQS_1	ODT	A9
50	GND	GND	GND
ODD	GND	GND	GND
Pin	E5849A Cable 1 Left Wing Connector	E5849A Cable 1 Right Wing Connector	E5849A Cable 2 Right Wing Connector

Connecting the E5849A Probe Cables to a Logic Analyzer

In a W4633A interposer setup, you make connections between an E5849A probe cable and a U4154A logic analyzer module by:

- First connecting the E5849A probe cable to a U4201A cable.
- Then connecting this U4201A cable to the relevant Logic Analyzer pod on the front panel of the U4154A module.

The following figure displays the relevant U4154A Logic Analyzer pods that you need to use to connect the right and left wings of the two E5849A probe cables used in a W4633A interposer setup.

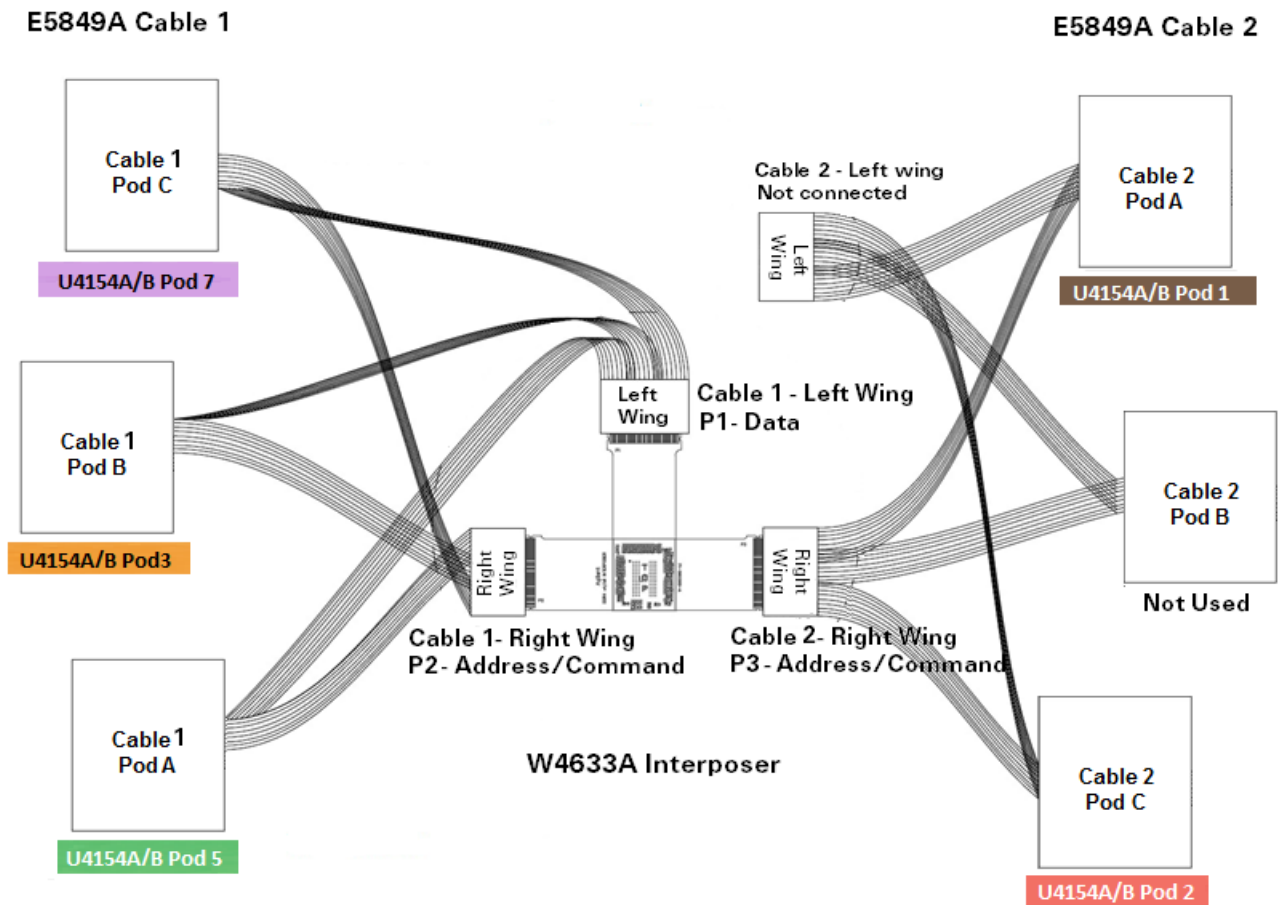

Figure 40 Connections between E5849A probe cables and Logic Analyzer pods

NOTE

You need four U4201A cables to make connections as per the above diagram, One U4201A cable connects E5849A Cable 2 Pod A and Pod C to Logic Analyzer. The other three U4201A cables connect E5849A Cable 1 Pod A, Pod B, and Pod C each to Logic Analyzer.

Logic Analyzer Channel Mapping



When you connect the E5849A probe cables to a U4154A Logic Analyzer as per the diagram in [Figure 40](#), the logic analyzer channels are mapped to signals as per the table displayed below.

These signals are automatically configured when you load one of the configuration files supplied with the Keysight B4621B decoder software.

The following table lists the mapping between the Logic Analyzer channels and signals when connected to E5849A probe cables, Cable 1 and Cable 2.

Note: Clock inputs are highlighted with yellow in this table.

Table 4 Signals and Logic Analyzer Channels Mapping for the E5849A Probe Cable

LA Channel	E5849A Cable 1 Pods			LA Channel	E5849A Cable 2 Pods		
	Pod A	Pod B	Pod C		Pod A	Pod B	Pod C
0	TDQS#	A6		0			
1	A10		A2	1	A7		
2	TDQS#	WE#	DQ5	2			
3	BG0		BA0	3	A5		BG1
4	DQS#	DQ5		4			C1
5		DQ7	A4	5	BA1		A3
6	DQS#	DQ7	DM#	6			
7		DQ6	PAR	7	ALERT#		CS#
8	ACT#	DQ6	DM#	8	A1		
9	DQ0	DQ2	A0	9			CAS#
10	C0	DQ2	DQ1	10	A13		
11	DQ0	DQS	A8	11			A12
12	ODT	DQS	DQ3	12	A9		
13	DQ4		DQ1	13			
14	C2		A11	14	A17		RAS#
15	DQ4		DQ3	15			
CLK		CKE	RST#	CLK	CK		
CLK#		PULLDN		CLK#	CK#		
LA Channel	Pod 5	Pod 3	Pod 7	LA Channel	Pod 1		Pod 2
U4154A/B Logic Analyzer Pods				U4154A/B Logic Analyzer Pods			

Signals not probed by the Logic Analyzer

The following signals are omitted from the Logic Analyzer connections for the W4633A interposer.

Interposer	Signal Name
W4633A	VREFCA, TEN, ZQ

7 Setting up the W4631A Interposer

W4631A Interposer Setup - Overview / 88

Mounting a W4631A Interposer on a PC Board using Riser and/or Sockets / 89

Connecting the W4631A Interposer to E5849A Probe Cables / 93

Connecting the E5849A Probe Cables to a Logic Analyzer / 97

W4631A Interposer Setup - Overview

- 1 Solder the riser, interposer, sockets, and memory components. (See [page 89](#))
- 2 Connect the interposer flex wings to E5849A probe cables. (See [page 93](#))
- 3 Connect the E5849A probe cables to a U4154A/B Logic Analyzer module's pods via U4201A logic analyzer cables. (See [page 97](#))

CAUTION

Use ESD precautions. Electrostatic discharge can damage components on your board or in the interposer. Use a grounded wrist strap and other ESD control measures as appropriate.

NOTE

Do not open the vacuum sealed packs of the W4631A interposer until you are ready to install the interposer. Discard these packs once the package is opened.

CAUTION

The balls on the bottom side of the Riser or Interposer can be easily damaged. Care must be taken handling the Interposer. If the balls become deformed due to handling, these may not interface the connector as intended.

Mounting a W4631A Interposer on a PC Board using Riser and/or Sockets

You can mount a W4631A interposer on a PC board using:

- either the DDR4 riser shipped with the interposer,
- or the HSIO Technologies Grypper Socket Model 96GRY7.5x13.1-0.80 (Part # 105526-0015)
- or both the riser and sockets.

Using at least one of the two components - sockets or a riser is however, mandatory for the mounting procedure.

You may use both sockets as well as a riser to allow for height restrictions on the PC Board and/or be able to swap various DDR memory devices in the stack up. The different combinations of components yield varying measurement results.

One of the possible combinations of these stacked up components is illustrated in the following figure. The mounting procedure for socket and riser is explained in the topic that follows.

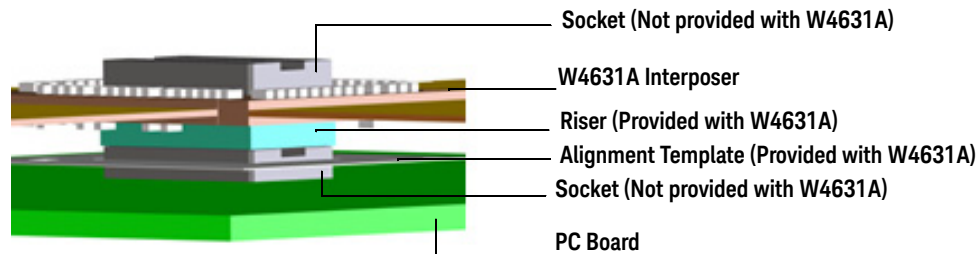

Figure 41 PC board, riser, optional Grypper sockets, and interposer stack up

After completing the mounting procedure, the desired DRAM is soldered to the top side of the interposer.

NOTE

A maximum of 12.5 mm x 19 mm DDR4 DRAM package can fit on top of the W4631A interposer without an additional riser or a socket mounted between the top of the interposer and DRAM.

Before Starting the Mounting Procedure

It is recommended that you:

- Review the Insertion and Removal Guide and other specifications mentioned for the socket on the HSIO Technologies website.
- Read the interposer and riser soldering guidelines and fabrication notes on [page 43](#).
- Ensure that neither the socket nor the mating part has any debris that could short or mechanically prevent the parts from completely seating properly. Examine the part and socket under a microscope and look for bits of solder that may have dislodged from the balls on a prior installation. Also, on the part with balls, the solder can be “wiped” by the Socket contacts and pile up at the base of the balls. This could result in either a short or can prevent the part and Socket from fully mating. Use a soft brush and air to remove any debris. Solder piled up at the base of the balls may require more intricate cleaning or removal procedures.

To mount the W4631A interposer on a PC board

- 1 Solder the socket to the top and the riser to the bottom of the W4631A interposer as per the soldering guidelines given on [page 43](#). You may opt not to use a socket or a riser while mounting. If you opt not to use the riser, it will be difficult to determine the alignment of interposer and socket on PC board visually in the next steps.
- 2 Install a socket on the PC board.

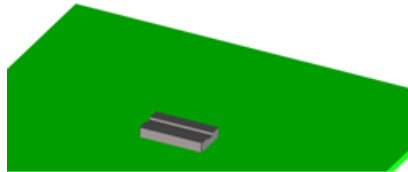

- 3 Install an Alignment Template on top of the socket that you installed in the previous step. When using a socket on the PC board, mounting the W4631A Interposer is aided by the use of an Alignment Template. This template is provided as a kit of six templates with the W4631A interposer. If required, you can also order this template kit as a replacement part W4631-60001.

NOTE

While installing the alignment template, ensure that the alignment template is oriented correctly to align its Pin 1 with the socket's Pin 1. Pin 1 is clearly identified with a marking on the alignment template as shown in the figure below.

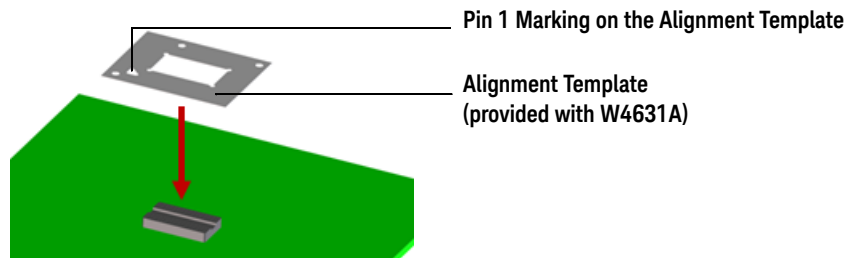

- 4 Orient the W4631A interposer set over the socket and alignment template that you installed in the previous step. Ensure that the interposer is oriented correctly to align its Pin 1 with the alignment template's Pin 1 as displayed in the figure below. The interposer set, in the figure below, has a riser installed at its bottom and a socket installed at the top.

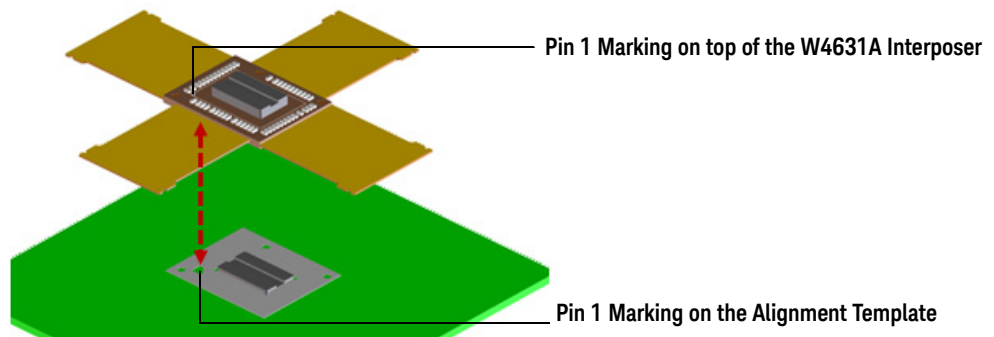

- 5 While keeping this orientation, gently lower the Interposer set towards the socket on the PC board so that the interposer just touches the socket.

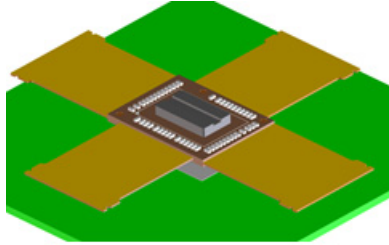

- 6 Observe and correct the alignment of the Interposer with the Alignment Template so that the interposer is positioned centered over the socket on the PC board. For the alignment to be correct, make sure that the corners and edges of the interposer are aligned with the corners and edges of the alignment template keeping the same amount of overlaps on the four corners.

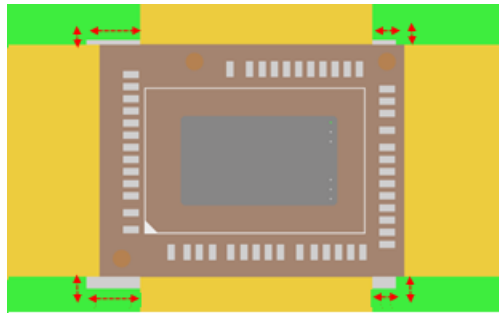

Interposer and Alignment Template NOT Aligned

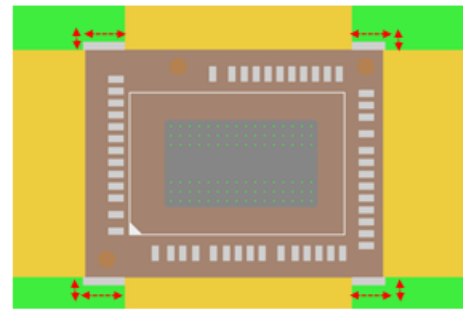

Aligned Interposer and Alignment Template

- 7 You can apply a small amount of finger pressure to the socket and move the Interposer around very slightly so that the balls on the bottom find the correct location over the socket and allow the assembly to be pressed into the socket on the PC board.
- 8 While maintaining finger pressure on top of interposer, place your index finger on the bottom of the PC board, directly under the socket and your thumb on the top of the interposer. If possible, try to observe under the Interposer to see if the riser is centered on the socket prior to pressing the Interposer into the socket. Care must be taken to NOT flex the board while pressing these components together.
- 9 When you are sure of the alignment, squeeze the interposer into the socket. It should “click” into position. Move your fingers to each end of the top socket and pinch to make sure the Interposer is fully seated in the socket on the PC board. As stated in the HSIO Socket Installation guide, it may require considerable force to seat the Interposer in the socket.

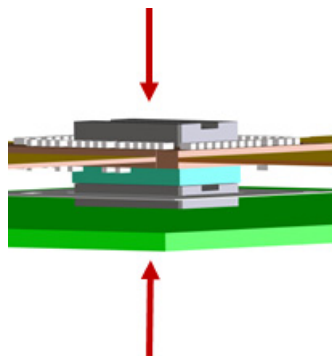

NOTE

If the PC board area is too large to allow your fingers to reach from the edge of the board to the socket location, then you will need to provide support under the board to apply pressure on the top. Care must be taken to NOT flex the board.

- 10 Finally, install the memory device to the socket on the top of the interposer. While doing so, be careful not to unseat the interposer from its socket. Support the PC board by applying finger pressure to its bottom while pressing the memory into the socket. Care must be taken to NOT flex the board while pressing these components together.

Though it is not recommended, you may install the memory device to the interposer before installing the interposer to the PC board. However, in such a situation, do NOT press the memory into the interposer socket with the balls on the bottom of the Interposer sitting on a flat, hard surface. This could deform the balls on the bottom of the Interposer. To avoid this, support the interposer balls with finger pressure while squeezing the memory into the socket.

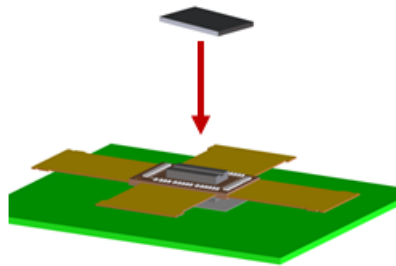

Connecting the W4631A Interposer to E5849A Probe Cables

After soldering the components or installing with Grypper socket(s), you can start connecting the W4631A interposer to the E5849A probe cables.

CAUTION

When using a socket at the bottom of interposer, ensure that:

- While attaching the probe cables to the interposer, apply finger pressure to the top of the interposer so as not to dislodge the interposer from the socket on the PC board.

Please handle the interposer with care and ensure that the wings on the W4631A interposer are properly latched to the ZIF connectors on the E5849A probe cables.

E5849A cables ship with labels unattached. Use the sheet of labels included with the E5949A to label one as "Cable 1" and a second as "Cable 2".

The following diagram illustrates how the W4631A interposer and E5849A cables have to be connected. As illustrated in the diagram:

- Two E5849A cables, *Cable 1* and *Cable 2* are used for a single W4631A interposer.
- The left and right wings of *Cable 1* connect to **J1-Data** and **J2-Address/Data** wings respectively of the interposer.
- The left and right wings of *Cable 2* connect to **J3-Address/Command** and **J4-Address/Data** wings respectively of the interposer.

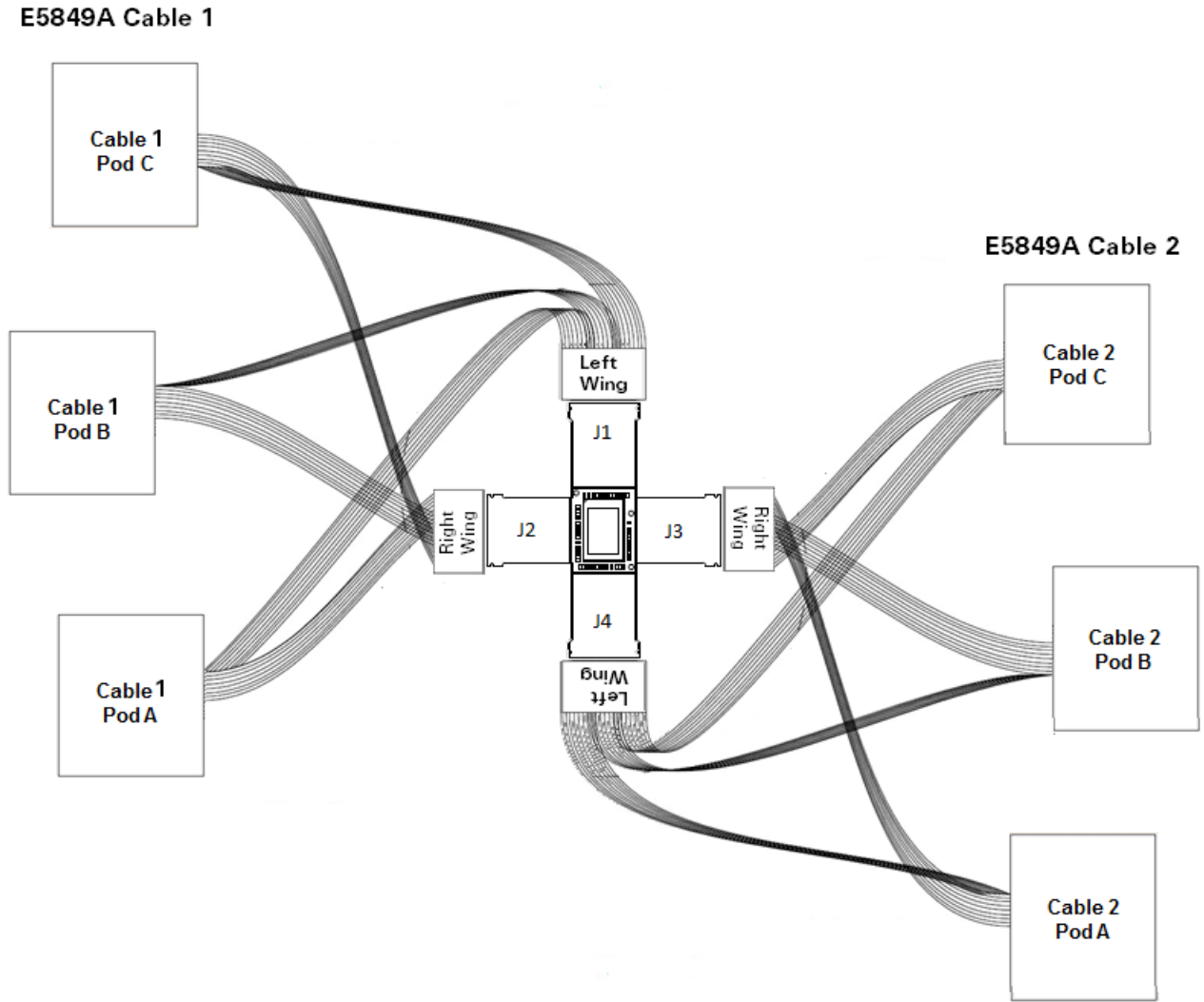

Figure 42 W4631A Interposer and E5849A Cable Connections

ZIF connectors on the E5849A cable connect to the bottom side of the flex wings on the W4631A interposer. ZIF doors close on the ground side of the flex wings. The following picture displays a W4631A interposer with E5849A ZIF connectors attached to its flex wings.

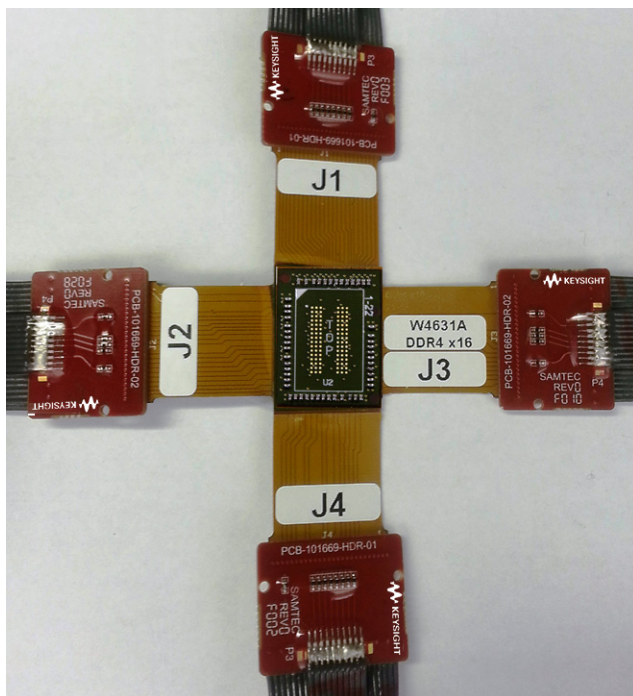

Figure 43 W4631A interposer attached to E5849A ZIF connectors

To attach an E5849A ZIF connector to a flex wing of the W4631A interposer, perform the following three steps.

- 1 Angle the flex wing of the interposer into an E5849A ZIF connector. GND towards door closure.
- 2 Align the E5849A ZIF connector tabs with interposer's wing notches.
- 3 Shut the ZIF door.

W4631A Interposer Wings Pinout

The following table lists the pinout of the four wings of a W4631A interposer.

In the table below:

- Clock inputs are highlighted with yellow.
- Signals beginning with an "X" are unused signals.
- Signals appended with _1 and _2 are double-probed signal pairs.
- DQS strobes are only single probed, but both polarities are probed.

Table 5 W4631A Interposer Wings Pinout

Pin	W4631A Interposer Wings			
	J1 - DATA	J2 - ADDRESS/DATA	J3 - ADDRESS/COMMAND	J4 - ADDRESS/DATA
2	DQU6_1	A11	X7	X22
4	DQU6_2	A8	X8	X23
6	DQU0_1	A0	X9	X24
8	DQU0_2	BA0	X10	X25
10	DQU2_1	BG0	X11	X26
12	DQU2_2	DQL6_1	X12	A12
14	DQL3_1	DQL6_2	DMU_1	A13
16	DQL3_2	DQL2_1	X14	A9
18	DQL1_1	DQL2_2	X15	DQL7_1
20	DQL1_2	CKE	X16	DQL7_2
22	DML_1	X1	DMU_2	X20
24	DML_2	PULLDN	X18	ACT_n
26	DQU7_1	RST_N	X19	A5
28	DQU7_2	DQL4_1	ODT	A1
30	DQSU_c	DQL4_2	CS_n	X2
32	DQSU_t	DQLO_1	A16	X3
34	DQL5_1	DQLO_2	A15	A4
36	DQL5_2	DQSL_t	BA1	A10
38	DQU1_1	DQSL_c	A3	X27
40	DQU1_2	X4	ALERT_n	A2
42	DQU3_1	X5	CK_t	A14
44	DQU3_2	X6	CK_c	A6
46	DQU5_1	DQU4_1	A7	PAR
48	DQU5_2	DQU4_2	X21	X28
50	GND	GND	GND	GND
ODD	GND	GND	GND	GND
Pin	E5849A Cable 1 Left Wing Connector	E5849A Cable 1 Right Wing Connector	E5849A Cable 2 Right Wing Connector	E5849A Cable 2 Left Wing Connector

Connecting the E5849A Probe Cables to a Logic Analyzer

In a W4631A interposer setup, you make connections between an E5849A probe cable and a U4154A/B logic analyzer module by:

- First connecting the E5849A probe cable to a U4201A cable.
- Then connecting this U4201A cable to the relevant Logic Analyzer pod on the front panel of the U4154A/B module.

The following figure displays the relevant U4154A/B Logic Analyzer pods that you need to use to connect the right and left wings of the two E5849A probe cables used in a W4631A interposer setup (for data rates under 2.5Gbs).

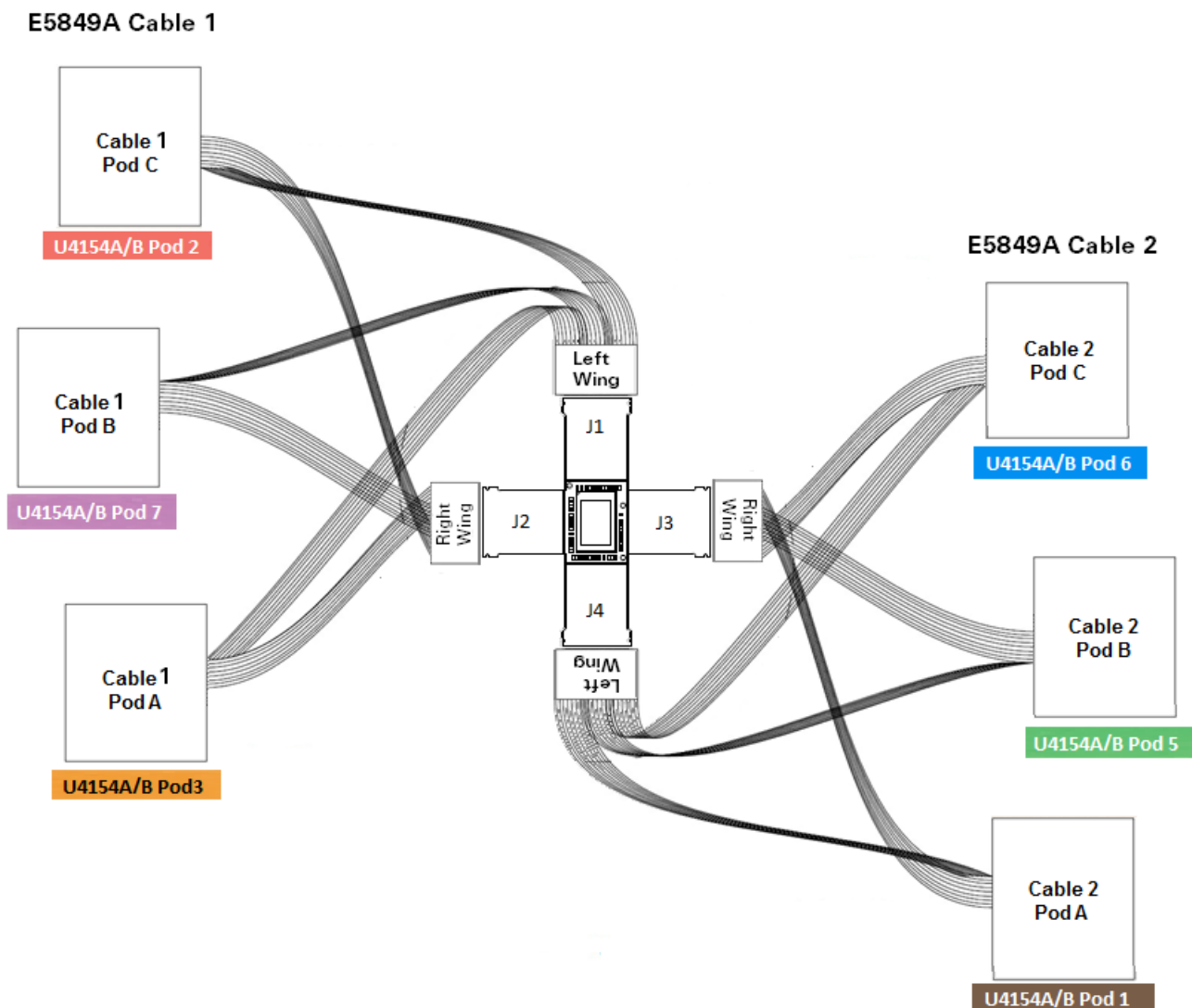

Figure 44 Connections between W4631A with two E5849A and pods of a single U4154A/B logic analyzer (for data rates under 2.5Gbs)

E5849A Cables to Logic Analyzer Pods Connection Mapping (for < 2.5 Gb/s Data Rates)

This default configuration uses two E5849A cables and a single U4154A/B module.

Logic Analyzer Pods	E5849A Cable Pods
Slot 1 Pod 1	Cable 2 Pod A
Slot 1 Pod 2	Cable 1 Pod C
Slot 1 Pod 3	Cable 1 Pod A
Slot 1 Pod 5	Cable 2 Pod B
Slot 1 Pod 7	Cable 1 Pod B
Slot 1 Pod 6	Cable 2 Pod C

DDR4 x16 ZIF Cable to Logic Analyzer Pods Connection Mapping (for < and > 2.5 Gb/s Data Rates)

This default configuration uses a single DDR4 x16 ZIF cable and a single U4154A/B module.

Logic Analyzer Pods	DDR4 x16 ZIF Cable Pods
Slot 1 Pod 1	Pod D
Slot 1 Pod 2	Pod E
Slot 1 Pod 3	Pod B
Slot 1 Pod 5	Pod A
Slot 1 Pod 7	Pod C

Logic Analyzer Channel Mapping

When you connect the E5849A probe cables to a U4154A/B Logic Analyzer as per the diagram in [Figure 44](#), the logic analyzer channels are mapped to signals as per the mapping tables [Table 6](#) and [Table 7](#) displayed below. [Table 6](#) provides mapping for a single-probed test setup for up to 2500 Mbps operation. [Table 7](#) provides mapping for a double probing test setup for above 2500 Mbps operations.

These signals are automatically configured when you load one of the configuration files supplied with the Keysight B4621B decoder software.

The following tables list the mapping between the Logic Analyzer channels and signals when connected to E5849A probe cables, Cable 1 and Cable 2.

In the tables below:

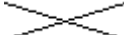
- Clock inputs are highlighted with yellow.
- Signals beginning with an "X" are unused signals.
- Signals appended with _1 and _2 are double-probed signal pairs.
- Table cells marked with  indicate pins that are not accessible with E5849A cables.

Logic Analyzer Channel Mapping For a single-probed test setup for up to 2500 Mbps operation

Table 6 Signals and Logic Analyzer Channels Mapping for the E5849A Probe Cable - Low Speed Connection Scheme

LA Channel	E5849A Cable 1 Pods		
	Pod A	Pod B	Pod C
0	DQU2_1	DQL6_2	
1	DQL0_2	X1	A11
2	DQU2_2	DQSL_t	DQU5_2
3	DQL0_1	 	DQL2_1
4	DQL3_2	DQU5_1	A0
5	DQL4_1	DQSU_t	DQL2_2
6	DQL3_1	DQSU_c	DQU3_2
7	DQL4_2	DQU7_2	A8
8	DQSL_c	DQU7_1	DQU3_1
9	DQU0_1	DML_2	BA0
10	X4	DML_1	DQU1_1
11	DQU0_2	DQL1_2	DQL6_1
12	DQU4_2	DQL1_1	DQL5_1
13	DQU6_2	 	DQU1_2
14	DQU4_1	 	BG0
15	DQU6_1	 	DQL5_2
CLK	X5	RST_N	CKE
CLK#	X6	PULLDN	
LA Channel	Pod 3	Pod 7	Pod 2
U4154A/B Logic Analyzer Pods			

LA Channel	E5849A Cable 2 Pods		
	Pod A	Pod B	Pod C
0	X26	DMU_1	
1	A15	DMU_2	X7
2	A12	BA1	X28
3	A16	 	X14
4	A9	PAR	X9
5	ODT	X3	X15
6	A13	X2	A6
7	CS_n	A1	X8
8	A3	A5	A14
9	X24	ACT_n	X10
10	ALERT_n	X20	X27
11	X25	DQL7_2	X12
12	X21	DQL7_1	A4
13	X23	 	A2
14	A7	 	X11
15	X22	 	A10
CLK	CK_t	X19	X16
CLK#	CK_c	X18	
LA Channel	Pod 1	Pod 5	Pod 6
U4154A/B Logic Analyzer Pods			

Logic Analyzer Channel Mapping For a Double Probing Test Setup for above 2500 Mbps Operations

For operations above 2500 Mbps, or when different read and write thresholds are required, the High Speed connections must be used.

In such situations, two U4154A/B modules are required for full probing of a single DDR4 x16 DRAM above 2500 Mbps. This Logic Analyzer Configuration uses dual sample mode as well as double probing to capture rising and falling edges of all dual data rate signals while maintaining separate read and write thresholds.

Table 7 Signals and Logic Analyzer Channels Mapping for the E5849A Probe Cable - High Speed Connection Scheme

LA Channel	E5849A Cable 1 Pods		
	Pod A	Pod B	Pod C
0	DQU2_1	DQL6_2	X
1	DQL0_2	X1	A11
2	DQU2_2	DQSL_t	DQU5_2
3	DQL0_1	X	DQL2_1
4	DQL3_2	DQU5_1	A0
5	DQL4_1	DQSU_t	DQL2_2
6	DQL3_1	DQSU_c	DQU3_2
7	DQL4_2	DQU7_2	A8
8	DQSL_c	DQU7_1	DQU3_1
9	DQU0_1	DML_2	BA0
10	X4	DML_1	DQU1_1
11	DQU0_2	DQL1_2	DQL6_1
12	DQU4_2	DQL1_1	DQL5_1
13	DQU6_2	X	DQU1_2
14	DQU4_1	X	BG0
15	DQU6_1	X	DQL5_2
CLK	X5	RST_N	CKE
CLK#	X6	PULLDN	X
LA Channel	Module 1 Pod 3	Module 1 Pod 7	Module 1 Pod 2
U4154A/B Logic Analyzer Pods			

LA Channel	E5849A Cable 2 Pods		
	Pod A	Pod B	Pod C
0	X26	DMU_1	X
1	A15	DMU_2	X7
2	A12	BA1	X28
3	A16	X	X14
4	A9	PAR	X9
5	ODT	X3	X15
6	A13	X2	A6
7	CS_n	A1	X8
8	A3	A5	A14
9	X24	ACT_n	X10
10	ALERT_n	X20	X27
11	X25	DQL7_2	X12
12	X21	DQL7_1	A4
13	X23	X	A2
14	A7	X	X11
15	X22	X	A10
CLK	CK_t	X19	X16
CLK#	CK_c	X18	X
LA Channel	Module 1 Pod 1	Module 2 Pod 5	Module 1 Pod 6
U4154A/B Logic Analyzer Pods			

Signals not probed by the Logic Analyzer

The following signals are omitted from the Logic Analyzer connections for the W4631A interposer.

Signal Name	Type	Description
VREFCA	Power Supply	Reference voltage for control, command, and address pins
TEN	Input	Connectivity test mode: LOW during normal operation
ZG	Reference	ZQ calibration reference

8 Setting up the W4636A Interposer

W4636A Interposer Setup - Overview / 104
Soldering the W4636A Interposer / 105
Connecting the W4636A Interposer to an E5847A Probe Cable / 106
Connecting the E5847A Probe Cable to a Logic Analyzer / 109

W4636A Interposer Setup - Overview

- 1 Solder the interposer, socket (optional), and memory components. (See [page 105](#))
- 2 Connect the interposer flex wings to an E5847A probe cable. (See [page 106](#))
- 3 Connect the E5847A probe cable to a U4154A/B Logic Analyzer module's pods via U4201A logic analyzer cables. (See [page 109](#))

CAUTION

Use ESD precautions. Electrostatic discharge can damage components on your board or in the interposer. Use a grounded wrist strap and other ESD control measures as appropriate.

NOTE

Do not open the vacuum sealed packs of the W4636A interposer until you are ready to install the interposer. Discard these packs once the package is opened.

Soldering the W4636A Interposer

The W4636A interposer needs to be attached to the DRAM PCB footprint on the design to be probed. The desired DRAM is soldered to the top side of the interposer. This attachment may occur in any order (i.e. first solder the interposer to the DUT, and then solder the DRAM to the interposer, or first solder the DRAM to the interposer, and then solder the DRAM+interposer assembly to the DUT). The interposer is designed to tolerate lead-free soldering temperature profiles. However, it is always recommended to apply the minimum temperature required and the minimum number of heating/cooling cycles to reduce risk of any damage to the interposer.

The stack up of these soldered components is illustrated in the following figure.

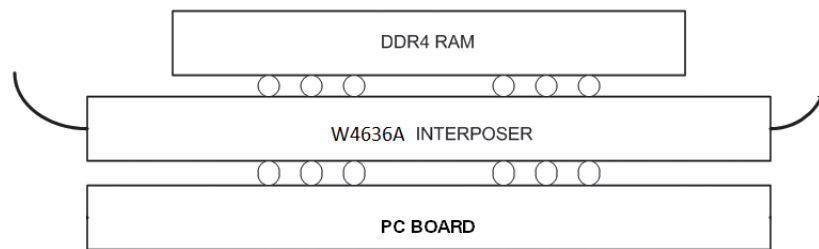

Figure 45 PC board, interposer, and DRAM stack up

NOTE

A maximum of 12.5 mm x 19 mm DDR4 DRAM package can fit on top of the W4636A interposer. No additional riser or a socket is required between the top of the interposer and DRAM.

Refer to the chapter ["Interposer and Riser Soldering Guidelines"](#) on page 61.

Connecting the W4636A Interposer to an E5847A Probe Cable

After soldering components, you can start connecting the W4636A interposer to the E5847A probe cable.

CAUTION

Please handle the interposer with care and ensure that the wings on the W4636A interposer are properly latched to the ZIF connectors on the E5847A probe cable.

The following diagram illustrates how the W4636A interposer and E5847A cable have to be connected. As illustrated in the diagram:

- One E5847A cable is used for a single W4636A interposer.
- The left and right wings of *the cable* connect to **P1** and **P2** wings respectively of the interposer.

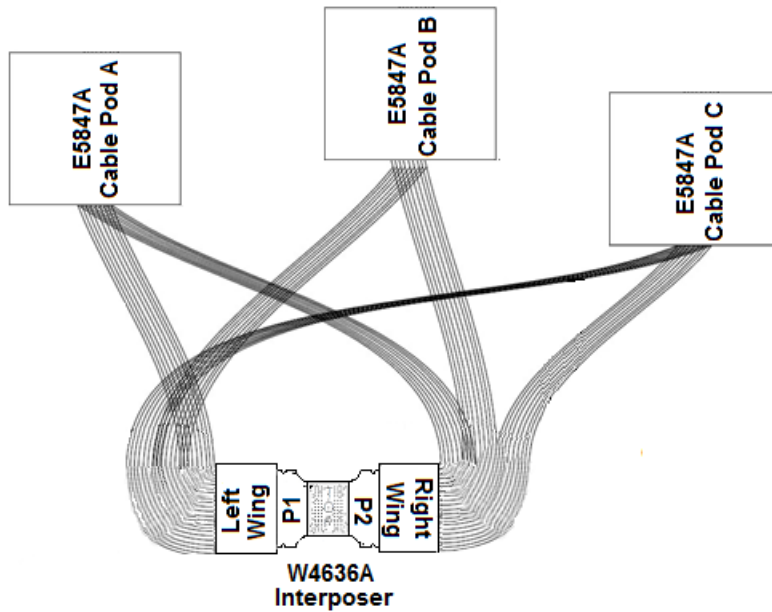

Figure 46 W4636A Interposer and E5847A Cable Connections

ZIF connector pin-outs on the E5847A cable connect to the top side of the flex wings on the W4636A interposer. ZIF doors close on the top side of the flex wings. The following picture displays a W4636A interposer with E5847A ZIF connectors attached to its flex wings.



Figure 47 W4636A interposer attached to E5847A ZIF connectors

To attach an E5847A ZIF connector to a flex wing of the W4636A interposer, perform the following three steps.

- 1 Angle the flex wing of the interposer into an E5847A ZIF connector. GND towards door closure.
- 2 Align the E5847A ZIF connector tabs with interposer's wing notches.
- 3 Shut the ZIF door.

W4636A Interposer Wings Pinout

The following table lists the pinout of the two wings of a W4636A interposer.

In the table below, clock inputs are highlighted with yellow.

Table 8 W4636A Interposer Wings Pinout

Pin	W4636A Interposer Wings	
	P1	P2
2	DQU0	A9
4	DQU2	A13
6	CKE	A5
8	GND	A7
10	DQU6	A1
12	DQU4	ALERT_n
14	-	BA1
16	DMU_n	A3
18	DQSL_c	A15
20	DQL0	A12
22	CS_n	RST_n
24	ODT	A16
26	A14	CK_c
28	ACT_n	CK_t
30	BG0	DQU7
32	BA0	DQU5
34	A10	DQU3
36	A4	DQU1
38	A6	DQSU_c
40	A0	-
42	A8	-
44	A11	-
46	A2	-
48	PAR	-
50	GND	GND
ODD	GND	GND
Pin	E5847A Cable Left Wing Connector	E5847A Cable Right Wing Connector

Connecting the E5847A Probe Cable to a Logic Analyzer

In a W4636A interposer setup, you make connections between an E5847A probe cable and a U4154A/B logic analyzer module by:

- First connecting the E5847A probe cable to a U4201A cable.
- Then connecting this U4201A cable to the relevant Logic Analyzer pod on the front panel of the U4154A/B module.

The following figure displays the relevant U4154A/B Logic Analyzer pods that you need to use to connect the right and left wings of a E5847A probe cable used in a W4636A interposer setup.

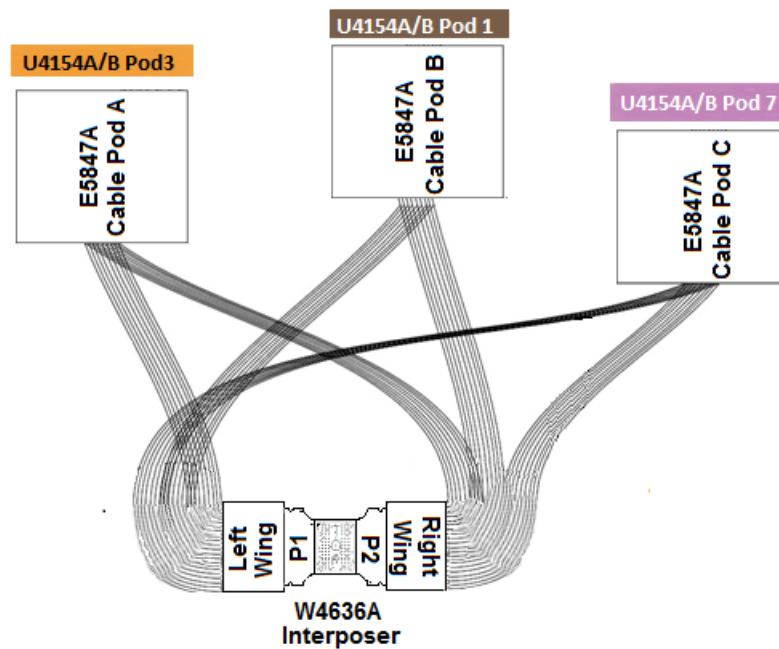

Figure 48 Connections between W4636A with a E5847A and pods of a single U4154A/B logic analyzer

U4154A/B Logic Analyzer Pods	DDR4 x16 ZIF Cable Pods
Slot 1 Pod 1	Pod B
Slot 1 Pod 3	Pod A
Slot 1 Pod 7	Pod C

Logic Analyzer Channel Mapping

When you connect the E5847A probe cable to a U4154A/B Logic Analyzer as per the diagram in [Figure 48](#), the logic analyzer channels are mapped to signals as per the mapping table [Table 9](#) displayed below.

These signals are automatically configured when you load one of the configuration files supplied with the Keysight B4621B decoder software.

In the table below:







- Clock inputs are highlighted with yellow.
- Signals beginning with an "X" are unused signals.
- Table cells marked with  indicate pins that are not accessible with an E5847A cable.

Table 9 Signals and Logic Analyzer Channels Mapping for the E5847A Probe Cable

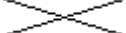
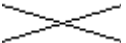
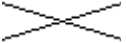
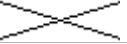
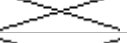
LA Channel	E5847A Cable Pods		
	Pod A	Pod B	Pod C
0	DQU0	BA1	A15
1	DQU1		A9
2	DQU2	A16	PAR
3	DQU3		A3
4	DQU4	A2	A5
5	DQU7	BA0	A12
6	DQU6	BG0	A11
7	DQU5	ACT_n	A13
8	DQSU_c	A14	A8
9		ODT	A7
10		CS_n	A6
11		DQL0	ALERT_n
12		DQSL_c	A4
13		DMU_n	A0
14			A1
15			A10
CLK	CKE	CK_t	RST_n
CLK#	GND	CK_c	
LA Channel	Pod 3	Pod 1	Pod 7
U4154A/B Logic Analyzer Pods			

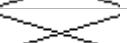
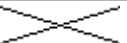
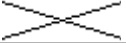
Signals not probed by the Logic Analyzer

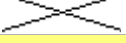
The following signals are omitted from the Logic Analyzer connections for the W4636A interposer.

Signal Name	Type
VREFCA	Control and other signals group
TEN	
ZQ	
DQS0	Data signal group
DQS1	
DQS1#	
DQ1	
DQ2	
DQ3	
DQ4	
DQ5	
DQ6	
DQ7	
DM0	

9 Setting up the W4643A Interposer

W4643A Interposer Setup - Overview / 114

Soldering the W4643A Interposer and Riser / 115

Connecting the W4643A Interposer to U4208A and U4209A Probe Cables / 116

Connecting the U4208A and U4209A Probe Cables to a U4164A Logic Analyzer / 119

W4643A Interposer Setup - Overview

- 1 Solder the riser, interposer, and memory components. (See [page 115](#))
- 2 Connect the interposer flex wings to U4208A and U4209A probe cables. (See [page 116](#))
- 3 Connect the U4208A and U4209A probe cables to a U4164A Logic Analyzer module's pods. (See [page 119](#))

CAUTION

Use ESD precautions. Electrostatic discharge can damage components on your board or in the interposer. Use a grounded wrist strap and other ESD control measures as appropriate.

NOTE

Do not open the vacuum sealed packs of the W4643A interposer until you are ready to install the interposer. Discard these packs once the package is opened.

Soldering the W4643A Interposer and Riser

For clearance issues, the W4643A interposer can be attached to the DRAM PCB footprint on the design to be probed with either the riser soldered or an optional Grypper socket (not included with the interposer) installed in between the interposer and PC board. The desired DRAM is soldered to the top side of the interposer. The stack up of these soldered components is illustrated in the following figure.

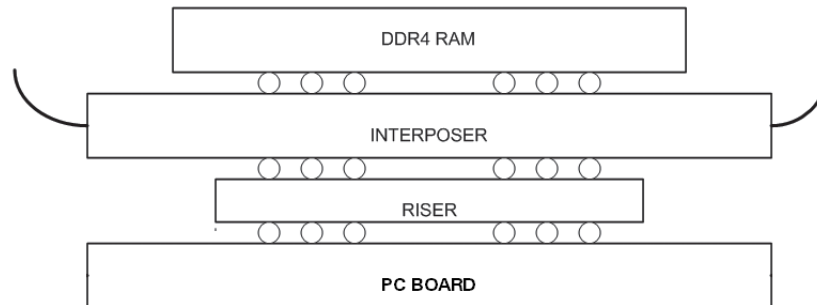

Figure 49 PC board, riser (or optional Grypper socket), interposer, and DRAM stack up

NOTE

A maximum of 11 mm x 13 mm DDR4 DRAM package can fit on top of the W4643A interposer without an additional riser or a socket on the top of the interposer and under DRAM.

Refer to the chapter "[Interposer and Riser Soldering Guidelines](#)" on page 61.

Connecting the W4643A Interposer to U4208A and U4209A Probe Cables

After soldering the components or installing with a Grypper socket, you can start connecting the W4643A interposer to the U4208A and U4209A probe cables.

NOTE

Please handle the interposer with care and ensure that the wings on the W4643A interposer are properly latched to the ZIF connectors on the U4208A and U4209A probe cables.

U4208A and U4209A cables ship with pod labels unattached. Use the sheet of labels included with the cable shipment to label pods as follows.

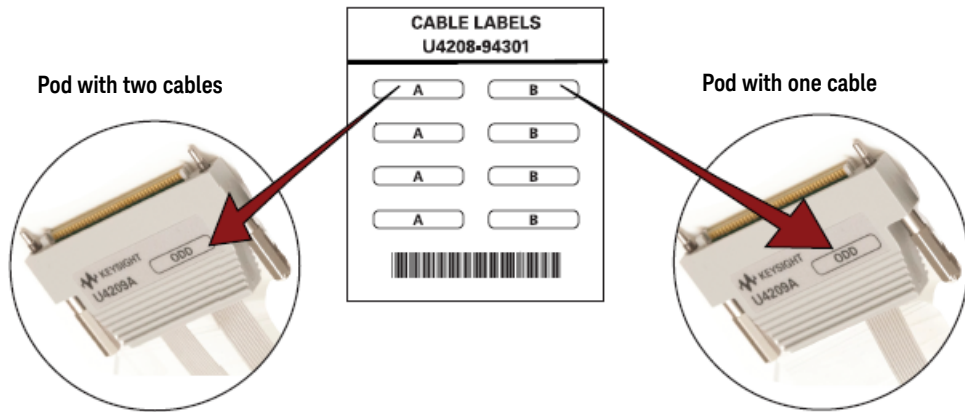

As illustrated in the diagram below, you need to connect:

- the U4208A probe cable to the left wing of the interposer.
- the U4209A probe cable to the right wing of the interposer.

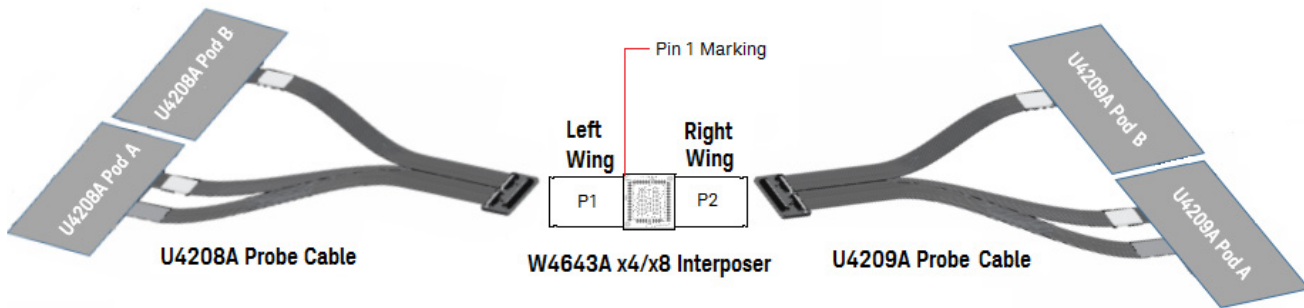

Figure 50 W4643A Interposer and U4208A / U4209A Probe Cable Connections

ZIF connectors on the U4208A/U4209A cable connect to the top side of the flex wings on the W4643A interposer. ZIF doors open on the top of the flex wings. The following picture displays a W4643A interposer with U4208A and U4209A ZIF connectors attached to its flex wings.

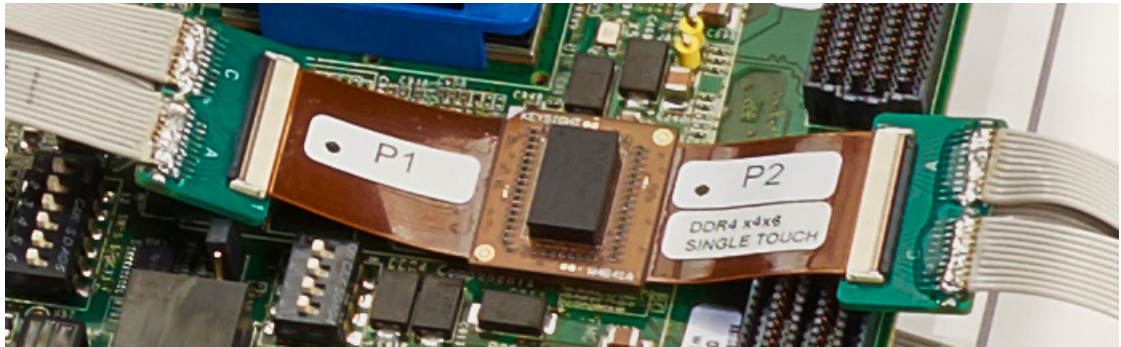

Figure 51 W4643A interposer attached to U4208A and U4209A ZIF connectors

To attach a U4208A or a U4209A ZIF connector to a flex wing of the W4643A interposer, perform the following three steps.

- 1 Angle the flex wing of the interposer into the probe cable's ZIF connector.
- 2 Align the probe cable's ZIF connector tabs with interposer's wing notches.
- 3 Shut the ZIF door.

W4643A Interposer Wings Pinout

The following table lists the pinout of the two wings of a W4643A interposer. The table includes the signals being probed when using the interposer in a dual sampling mode or a quad sampling mode (supported by the U4164A logic analyzer module).

In this table,

- Clock/Qualifier inputs are highlighted with yellow
- Signals that can be quad-sampled are highlighted with green
- Single/dual sampled signals are highlighted with blue
- Table cells marked with indicate pins that are not accessible.

Table 10 W4643A Interposer Wings Pinout

Pin	W4643A Interposer Wings	
	Right Wing	Left Wing
2		A0
4		PAR
6		A2
8	DBI_n	A11
10		
12		
14	DQ1	
16	DQ3	A8
18	DQ7	A6
Pin	U4209A	U4208A

Pin	W4643A Interposer Wings	
	Right Wing	Left Wing
20	DQ5	BA0
22		A4
24	CS_n	BG0
26	C1	A10
28	ALERT_n	A14
30	CK_c	CKE
32	CK_t	GND
34	A16	C0
36	A12	ACT_n
38	BG1	C2
40	BA1	ODT
42	A15	DQ6
44	A3	DQ4
46	A5	
48	A7	DQ0
50		RST_n
52		GND
54	A13	DQS_t
56	A1	DQS_c
58	A17	DQ2
60	A9	TDQS_c
Pin	U4209A	U4208A

Connecting the U4208A and U4209A Probe Cables to a U4164A Logic Analyzer

In a W4643A interposer setup, you connect the U4208A and U4209A probe cable pods to U4164A logic analyzer pods as per the mapping shown in the table below.

Probe Cable Pods	U4164A Logic Analyzer Pods
U4209A Cable Pods	
Pod A	Pod 1 (signals are dual-sampled on this pod)
Pod B	Pod 5 (signals can be quad-sampled on this pod)
U4208A Cable Pods	
Pod A	Pod 3 (signals are dual-sampled on this pod)
Pod B	Pod 7 (signals can be quad-sampled on this pod)

NOTE

In a dual-sampled setup, the U4164A logic analyzer samples data twice per clock edge. Two thresholds are used with one sample taken per threshold. For DDR systems running less than 2.5GHz, the dual sampling allows separate thresholds and separate sample positions to be specified for DDR Reads and Writes.

In a quad-sampled setup, four samples are taken per clock edge. Two thresholds are used with two samples taken per threshold.

The mapping of the U4208A and U4209A probe cable pods and logic analyzer pods is also illustrated with the help of the following diagram.

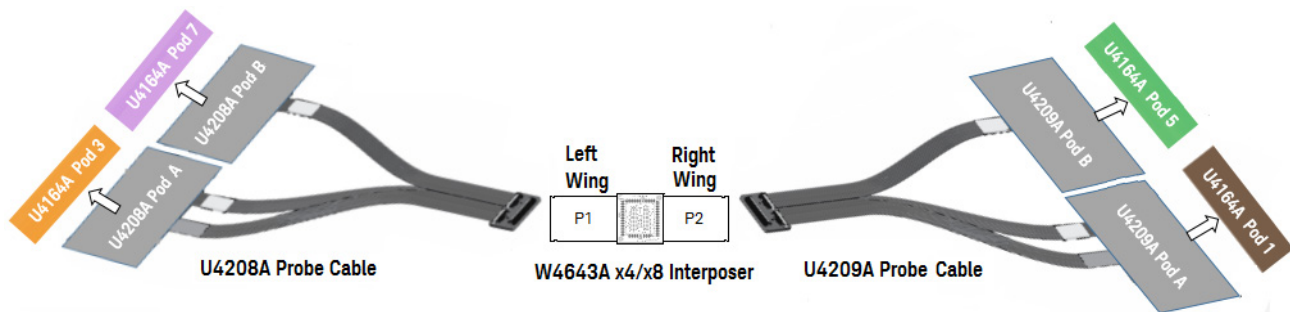

Figure 52 Connections between U4208A and U4209A probe cables and Logic Analyzer pods

Logic Analyzer Channels to Signals Mapping

When you connect the U4208A and U4209A probe cables to a U4164A Logic Analyzer as per the connection diagram in Figure 52, the logic analyzer channels are mapped to DDR4 signals as per the table displayed below.

These signals are automatically configured when you load one of the configuration files supplied with the Keysight B4661A decoder software.

Notes:

- Clock inputs for each logic analyzer pod are highlighted with yellow in this table.
- Table cells marked with  indicate logic analyzer channels that are not accessible.

Table 11 Signals and Logic Analyzer Channels Mapping when using the W4643A Interposer

Logic Analyzer Pod and its Channels		Signals on U4208A probe cable Pod A	Logic Analyzer Pod and its Channels		Signals on U4208A probe cable Pod B
	0	A0		0	DQ6
	1	PAR		1	
	2	A2		2	DQ4
	3	A11		3	
	4			4	
	5	A8		5	
	6	A6		6	DQ0
Pod 3	7	BA0	Pod 7	7	
(Signals can be dual-sampled on this pod)	8	A4	(Signals can be quad-sampled on this pod)	8	DQS_t
	9	BG0		9	
	10	A10		10	DQS_c
	11	A14		11	
	12	C0		12	DQ2
	13	ACT_n		13	
	14	C2		14	TDQS_c
	15	ODT		15	
	CLK	CKE		CLK	RST_n
	CLK#	GND		CLK#	GND

Logic Analyzer Pod and its Channels		Signals on U4209A probe cable Pod A	Logic Analyzer Pod and its Channels		Signals on U4209A probe cable Pod B
	0	A9		0	DQ5
	1	A17		1	
	2	A1		2	DQ7
	3	A13		3	
	4	A7		4	DQ3
	5	A5		5	
	6	A3		6	DQ1
Pod 1	7	A15	Pod 5	7	
(Signals can be dual-sampled on this pod)	8	BA1	(Signals can be quad-sampled on this pod)	8	DBI_n
	9	BG1		9	
	10	A12		10	
	11	A16		11	
	12	ALERT_n		12	
	13	C1		13	
	14	CS_n		14	
	15			15	
	CLK	CK_t		CLK	
	CLK#	CK_c		CLK#	

Signals not probed by the Logic Analyzer

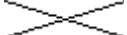
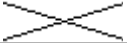
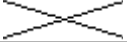
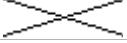
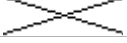
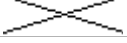
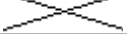
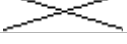
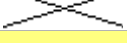
The following signals are omitted from the Logic Analyzer connections for the W4643A interposer.

Interposer	Signal Name
W4643A	VREFCA, TEN, ZQ, DQSL_c

10 Setting up the W4641A Interposer

W4641A Interposer Setup - Overview / 124

Soldering the W4641A Interposer / 125

Connecting the W4641A Interposer to U4208A and U4209A Probe Cables / 126

Connecting the U4208A and U4209A Probe Cables to a U4164A Logic Analyzer / 129

W4641A Interposer Setup - Overview

- 1 Solder the interposer, socket (optional), and memory components. (See [page 125](#))
- 2 Connect the interposer flex wings to U4208A and U4209A probe cables. (See [page 126](#))
- 3 Connect the U4208A and U4209A probe cables to a U4164A Logic Analyzer module's pods. (See [page 129](#))

CAUTION

Use ESD precautions. Electrostatic discharge can damage components on your board or in the interposer. Use a grounded wrist strap and other ESD control measures as appropriate.

NOTE

Do not open the vacuum sealed packs of the W4641A interposer until you are ready to install the interposer. Discard these packs once the package is opened.

Soldering the W4641A Interposer

The W4641A interposer needs to be attached to the DRAM PCB footprint on the design to be probed. The desired DRAM is soldered to the top side of the interposer. This attachment may occur in any order (i.e. first solder the interposer to the DUT, and then solder the DRAM to the interposer, or first solder the DRAM to the interposer, and then solder the DRAM+interposer assembly to the DUT). The interposer is designed to tolerate lead-free soldering temperature profiles. However, it is always recommended to apply the minimum temperature required and the minimum number of heating/cooling cycles to reduce risk of any damage to the interposer.

The stack up of these soldered components is illustrated in the following figure.

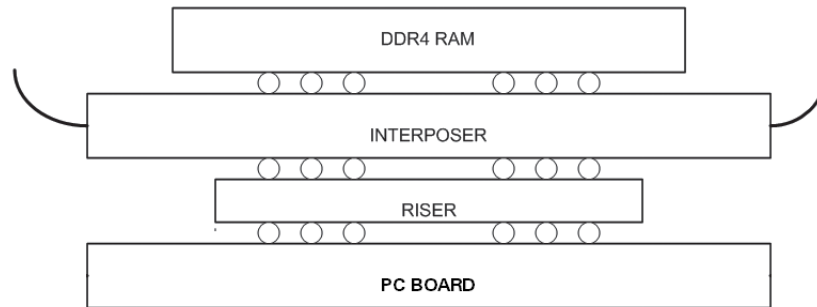

Figure 53 PC board, riser, interposer, and DRAM stack up

NOTE

A maximum of 10 mm x 14 mm DDR4 DRAM package can fit on top of the W4641A interposer.

Refer to the chapter "[Interposer and Riser Soldering Guidelines](#)" on page 61.

Connecting the W4641A Interposer to U4208A and U4209A Probe Cables

After soldering components, you can start connecting the W4641A interposer to the U4208A and U4209A probe cables.

CAUTION

Please handle the interposer with care and ensure that the wings on the W4641A interposer are properly latched to the ZIF connectors on the U4208A and U4209A probe cables.

U4208A and U4209A cables ship with pod labels unattached. Use the sheet of labels included with the cable shipment to label pods as follows.

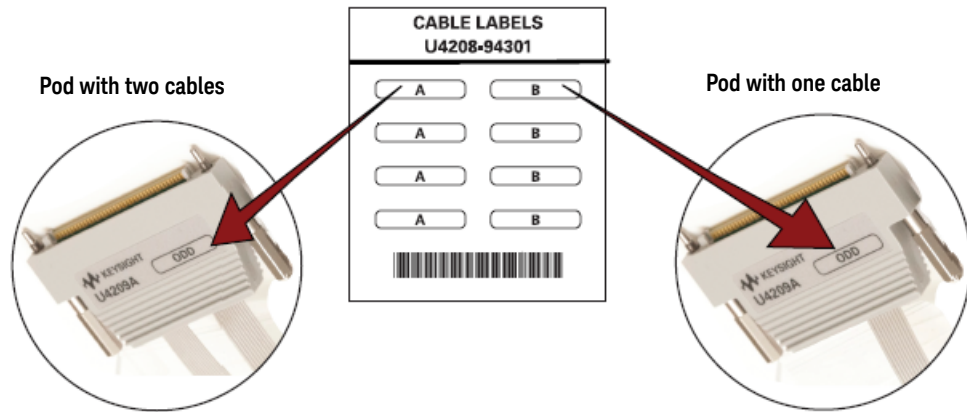

As illustrated in the diagram below, you need to connect:

- the U4208A probe cable to the left wing of the interposer.
- the U4209A probe cable to the right wing of the interposer.

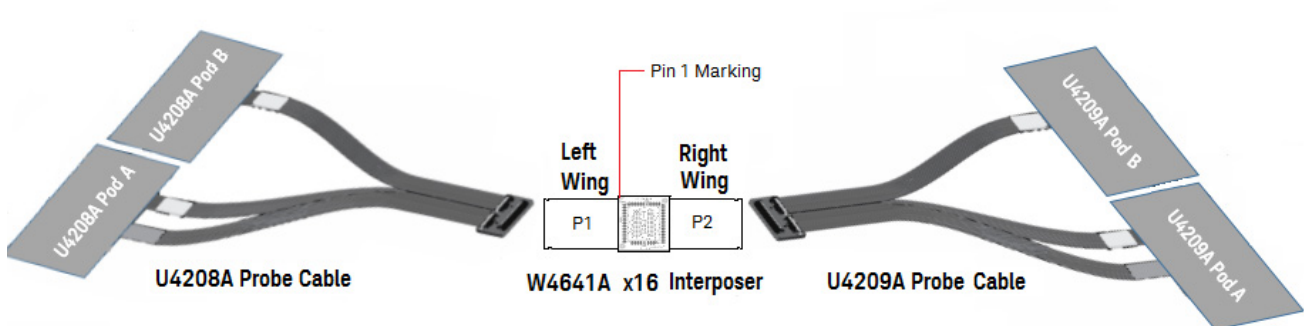

Figure 54 W4641A Interposer and U4208A / U4209A Probe Cable Connections

ZIF connectors on the U4208A/U4209A cable connect to the top side of the flex wings on the W4641A interposer. ZIF doors open on the top of the flex wings. The following picture displays a W4641A interposer with U4208A and U4209A ZIF connectors attached to its flex wings.

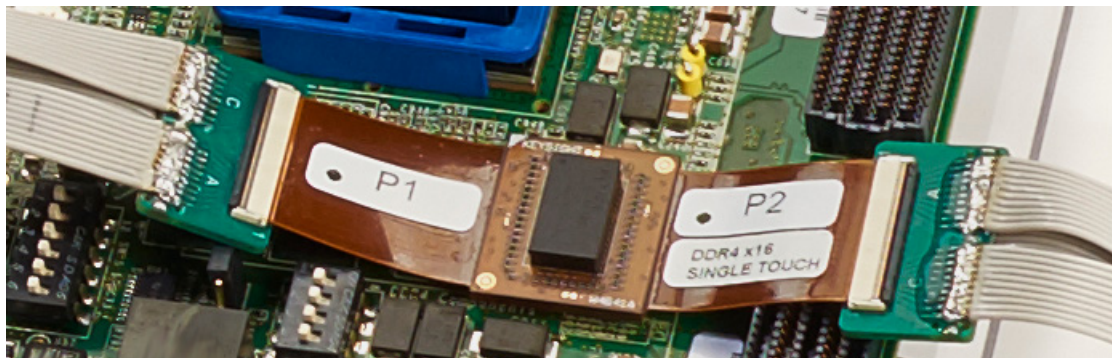

Figure 55 W4641A interposer attached to U4208A and U4209A ZIF connectors

To attach a U4208A or a U4209A ZIF connector to a flex wing of the W4641A interposer, perform the following three steps.

- 1 Angle the flex wing of the interposer into the probe cable's ZIF connector.
- 2 Align the probe cable's ZIF connector tabs with interposer's wing notches.
- 3 Shut the ZIF door.

W4641A Interposer Wings Pinout

The following table lists the pinout of the two wings of a W4641A interposer. The table includes the signals being probed when using the interposer in a dual sampling mode or a quad sampling mode (supported by the U4164A logic analyzer module).

In this table,

- Clock/Qualifier inputs are highlighted with yellow
- Signals that can be quad-sampled are highlighted with green
- Dual-sampled signals are highlighted with blue
- Table cells marked with indicate pins that are not accessible.

Table 12 W4641A Interposer Wings Pinout

Pin	W4641A Interposer Wings	
	Right Wing	Left Wing
2	DQL1	A4
4	DQU1	A2
6	DQU3	A0
8	DQU5	A10
10	DQSU_c	
12	DQSU_t	
14	DQU7	PAR
16	DQL3	A11
Pin	U4209A	U4208A

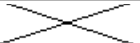
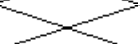
Pin	W4641A Interposer Wings	
	Right Wing	Left Wing
18	DQL5	A8
20	DQL7	A6
22	DML_n	BA0
24	DML_n	BG0
26	CS_n	ACT_n
28	A16	ODT
30	CK_c	CKE
32	CK_t	GND
34		A14
36	A15	DQSL_t
38	BA1	DMU_n
40	ALERT_n	DMU_n
42	A5	DQL6
44	A7	DQL2
46	A13	DQL4
48	A12	DQU4
50		RST_n
52		GND
54	A1	DQU6
56	A9	DQU0
58		DQU2
60	A3	DQL0
Pin	U4209A	U4208A

Connecting the U4208A and U4209A Probe Cables to a U4164A Logic Analyzer

In a W4641A interposer setup, you connect the U4208A and U4209A probe cable pods to U4164A logic analyzer pods as per the mapping shown in the table below.

Probe Cable Pods	U4164A Logic Analyzer Pods
U4209A Cable Pods	
Pod A	Pod 1 (signals are dual-sampled on this pod)
Pod B	Pod 5 (signals can be quad-sampled on this pod)
U4208A Cable Pods	
Pod A	Pod 3 (signals are dual-sampled on this pod)
Pod B	Pod 7 (signals can be quad-sampled on this pod)

NOTE

In a dual-sampled setup, the U4164A logic analyzer samples data twice per clock edge. Two thresholds are used with one sample taken per threshold. For DDR systems running less than 2.5GHz, the dual sampling allows separate thresholds and separate sample positions to be specified for DDR Reads and Writes.

In a quad-sampled setup, four samples are taken per clock edge. Two thresholds are used with two samples taken per threshold.

The mapping of the U4208A and U4209A probe cable pods and logic analyzer pods is also illustrated with the help of the following diagram.

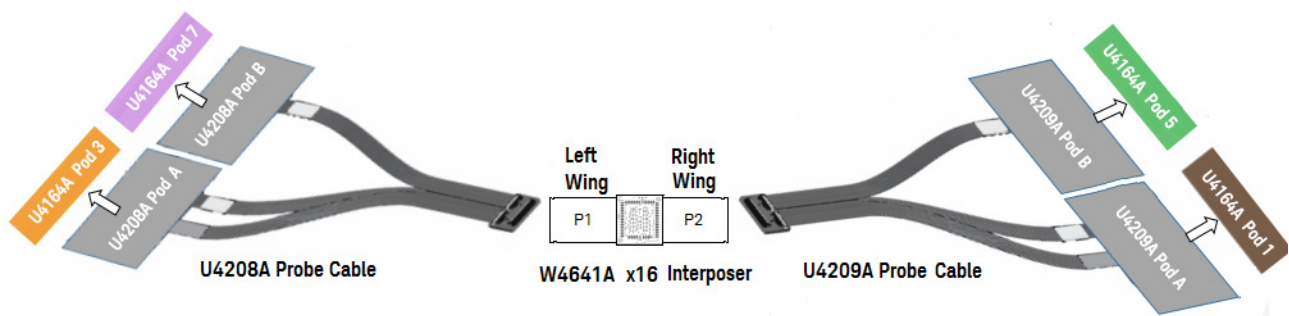

Figure 56 Connections between U4208A and U4209A probe cables and Logic Analyzer pods

Logic Analyzer Channels to Signals Mapping

When you connect the U4208A and U4209A probe cables to a U4164A Logic Analyzer as per the connection diagram in [Figure 56](#), the logic analyzer channels are mapped to DDR4 signals as per the table displayed below.

These signals are automatically configured when you load one of the configuration files supplied with the Keysight B4661A decoder software.

Notes:

- Clock inputs for each logic analyzer pod are highlighted with yellow in this table.
- Table cells marked with  indicate logic analyzer channels that are not accessible.

Table 13 Signals and Logic Analyzer Channels Mapping when using the W4641A Interposer

Logic Analyzer Pod and its Channels		Signals on U4208A probe cable Pod A	Logic Analyzer Pod and its Channels		Signals on U4208A probe cable Pod B
Pod 3 (Signals can be dual-sampled on this pod)	0	A4	Pod 7 (Signals can be quad-sampled on this pod)	0	DQL6
	1	A2		1	
	2	A0		2	DQL2
	3	A10		3	
	4	PAR		4	DQL4
	5	A11		5	
	6	A8		6	DQU4
	7	A6		7	
	8	BA0		8	DQU6
	9	BG0		9	
	10	ACT_n		10	DQU0
	11	ODT		11	
	12	A14		12	DQU2
	13	DQSL_t		13	
	14	DMU_n		14	DQL0
	15	DMU_n		15	
	CLK	CKE		CLK	RST_n
	CLK#	GND		CLK#	GND

Logic Analyzer Pod and its Channels		Signals on U4209A probe cable Pod A	Logic Analyzer Pod and its Channels		Signals on U4209A probe cable Pod B
Pod 1 (Signals can be dual-sampled on this pod)	0	A3	Pod 5 (Signals can be quad-sampled on this pod)	0	DQL7
	1			1	
	2	A9		2	DQL5
	3	A1		3	
	4	A12		4	DQL3
	5	A13		5	
	6	A7		6	DQU7
	7	A5		7	
	8	ALERT_n		8	DQU5
	9	BA1		9	
	10	A15		10	DQU3
	11			11	
	12	A16		12	DQU1
	13	CS_n		13	
	14	DML_n		14	DQL1
	15	DML_n		15	
	CLK	CK_t		CLK	DQSU_t
	CLK#	CK_c		CLK#	DQSU_c

Signals not probed by the Logic Analyzer

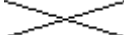
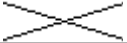
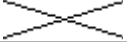
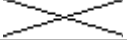
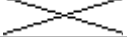
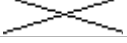
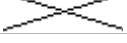
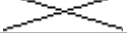
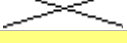
The following signals are omitted from the Logic Analyzer connections for the W4641A interposer.

Interposer	Signal Name
W4641A	VREFCA, TEN, ZQ, DQSL_c

11 Setting Up the Logic Analyzer for W5643A and W4630/40-Series Interposers

Before You Start / 134
Using DDR Setup Assistant / 135
Loading a Configuration File / 136

Before You Start

Ensure that all the software components needed for the interposer are installed on the host computer and the required software licenses are also obtained and installed.

You can find the software requirements specific to your interposer in the following topics in this guide.

- [“Hardware and Software Requirements”](#) on page 17 for W5643A
- [“Hardware and Software Requirements”](#) on page 34 for W4630-series
- [“Hardware and Software Requirements”](#) on page 53 for W4640-series

Using DDR Setup Assistant

One of the tools included in the software requirements for these interposers is the DDR Setup Assistant tool. This tool is available at no charge as part of the Keysight B4661A memory analysis software package.

This tool simplifies measurement setup and minimizes the time to tune state mode measurements on the logic analyzer. DDR Setup Assistant guides you through even the most complex logic analyzer setup in minutes. It includes a variety of powerful, time-saving trigger features optimized for DDR measurements. The tool automatically configures optimum thresholds and controls DDR eye finder scans to rapidly locate optimal sample positions.

The following shortcut icon gets added to your desktop on installing this tool.

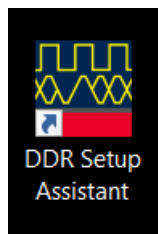

Figure 57 DDR Setup Assistant icon on installation

DDR Setup Assistant

Steps in DDR setup:

- Specify Input Parameters
- Verify Software Installation
- Load Configuration File
- Do Hardware Setup
- Set Initial Thresholds
- Set Sample Positions of Clk/CS Signals
- Set Sample Positions of Command/Addr Signals
- Find Latency Values
- Set Sample Positions of Data Read/Write
- Save Setup

Setting up: DDR5 -> BGA -> W5643A -> Mirroring No -> CAI No

The first step is for you to provide some information about your target system, probing solution, and logic analyzer module.

Which logic analyzer module will you be

What is the DDR bus type?

What probing solution are you using?

BGA model

Is mirroring active on this

Is cdm/addr inversion active on this DRAM?

Figure 58 Opening screen on launching the DDR Setup Assistant

Loading a Configuration File

NOTE

Though you have the option to manually load a configuration for your interposer in the Logic Analyzer, Keysight highly recommends using the DDR Setup Assistant tool instead of loading configurations manually.

The mapping of specific signals to logic analyzer channels depends on:

- Which DRAMs are being probed.
- How SRAM circuit is designed.
- Which interposer is being used.
- How the probe cables and logic analyzer cables are arranged when connecting each specific interposer to the logic analyzer module.

Because of these dependencies, there is no single logic analyzer configuration file setup for the W5643A, W4630-series and W4640-series interposers. A set of DDR5 and DDR4 x4, x8, and x16 configuration files is provided with the Keysight DDR Decoder software. To obtain this set of configuration files, you must install the latest version of the **B4661A software** for the specific interposer model number you are using. Licensing of this software is not required for obtaining the configurations files. From this set of configuration files, you can load a configuration file that suits your specific requirements in the Logic and Protocol analyzer GUI.

When you load a configuration file, it will set up buses and signals, add the decoder tool, and add a listing tool in the Logic and Protocol Analyzer GUI.

To load a provided configuration file:

- 1 Close the logic analyzer GUI window, if it is open.
- 2 Navigate to the following folder that contains all the DDR configuration files.
Users/Public/Public Documents/Keysight Technologies/Logic Analyzer/Default Configs/Keysight/DDR Bus Decoder
- 3 Select the DDR bus type.
- 4 Select the **BGA** and then choose a configuration file corresponding to the bus size and speed.
- 5 Double-click the configuration file to open it.

When you click on a configuration file, the Logic and Protocol Analyzer software will start and configure itself to use the decoder.

The logic analyzer Buses/Signals setup dialog allows you to assign descriptive labels to each analyzer channel that associate each channel with the particular DRAM and DRAM signal being probed.

NOTE

If your unique multi-DRAM configuration is not covered by one of the default configurations, you can use the *DDR Custom Configuration Creator* tool installed with the B4661A Memory Analysis SW package to create your own custom DDR BGA configuration.

NOTE

It is recommended that you use the **Advanced Probe Settings (APS)** for all signals on all W4630A series DDR4 BGA interposers. For instructions, refer to the application note "**Capture Highest DDR3 Data rates using Advanced Probe Settings**" available at: <http://literature.cdn.keysight.com/litweb/pdf/5991-0799EN.pdf?id=2284314>.

To save a configuration file

After you set up the logic analyzer, it is strongly recommended that you save the configuration.

To save your work, select **File>Save As...** and save the configuration as an ALA format file.

ALA format configuration files are more complete and efficient than XML format configuration files. See the Logic and Protocol Analyzer online help for more information on these formats.

12 Characteristics, Regulatory, Safety and Storage Information

Operating Characteristics / 140
Storage, Inspection, Baking, and Cleaning Guidelines / 141
Safety Checks and Warnings / 142
Safety Information for the E5849A and E5847A Cable Adapters / 143
Regulatory Notices / 144

Operating Characteristics

The following operating characteristics are not specifications, but are typical operating characteristics.

Characteristics	Description
Temperature	Operating: +5° C to +40° C Non Operating : - 40 ° C to +70° C
Altitude	4,600 m (15,000 ft)
Relative Humidity Range Noncondensing	50% RH Min/80% RH Max at 40° C noncondensing. Avoid sudden, extreme temperature changes which could cause condensation on the circuit board. For indoor use only.

Characteristics	Description
To interposer	Memory bus signals from target system
From interposer	High-density connectors for Keysight U4154A/B and U4164A AXIe-based logic analyzer modules

Storage, Inspection, Baking, and Cleaning Guidelines

The following are some of the guidelines for storing, shelf life, and cleaning of the interposers documented in this guide.

Guidelines for Shelf Life and Solder-ability of Interposers

If your Interposer exceeds shelf life (1 year) before solder into application, use the following inspection and baking method.

- Inspect the humidity indicator within moisture proof vacuum sealed bag(s).
- If the humidity indicator shows moisture then bake the board at 120 °C for 4 hours and perform the solder-ability test.
- If the test passes, proceed with the assembly (reflow) of interposer.
- If delamination occurs, the interposer cannot be used.

Cleaning of Interposer Gold Fingers

- Use Isopropyl alcohol to clean interposer contacts.
- Never use abrasive cleaning materials.

Safety Checks and Warnings



This manual provides information and warnings essential for operating the products described in this manual in a safe manner and for maintaining these in safe operating condition. To ensure safe operation and to obtain maximum performance from these products, carefully read and observe the following warnings, cautions, and notes.

These products have been designed and tested in accordance with accepted industry standards, and have been supplied in a safe condition.

To avoid personal injury and to prevent fire or damage to these products or products connected to these, review and comply with the following safety precautions.

WARNING

Indoor Use Only.

Do not operate in wet/damp environments. Keep product surfaces dry and clean.

WARNING

Periodically inspect the interposer and cable wires to check for any damage. Do Not Operate With Visible or Suspected Failures. If you suspect there is damage, have it inspected by a Keysight authorized service personnel.

WARNING

These interposers are NOT intended for measurements on mains circuits (CAT II, CAT III, and CAT IV).

WARNING

Do not operate the interposer in the presence of flammable gasses or fumes. Operation of any electrical instrument in such an environment constitutes a definite safety hazard.

WARNING

If the interposer/cable is used in a manner not specified by the manufacturer, the protection provided by it may be impaired.

WARNING



Do not install substitute parts or perform any unauthorized modification to the interposer/cable. Do not attempt internal service or adjustment. Service should be carried out by a Keysight Technologies authorized service personnel. For any service needs, contact Keysight Technologies.

Safety Information for the E5849A and E5847A Cable Adapters

To clean the instrument

Do not attempt to clean this product.

Safety Symbols

Safety Symbol	Description
	"Caution" or "Warning" risk of danger marked on product. See "Safety Notices" on page 2 and refer to this manual for a description of the specific danger.
	Hazardous voltage symbol.
	Earth terminal symbol: Used to indicate a circuit common connected to grounded chassis.

Regulatory Notices

WEEE Compliance

Safety Symbol	Description
	<p>This product complies with the WEEE Directive (2002/96/EC) marking requirements. The affixed label indicates that you must not discard this electrical/electronic product in domestic household waste.</p> <p><i>Product Category: With reference to the equipment types in the WEEE Directive Annex I, this product is classed as a "Monitoring and Control Instrumentation" product.</i></p> <p>Do not dispose in domestic household waste. To return unwanted products, contact your local Keysight office, or see "www.keysight.com" for more information.</p>

China RoHS

W5643A, W4631A, W4633A, W4636A, W4641A, W4643A, E5849A, and E5847A



Index

A

alignment template, [90](#)

B

B4621B decoder software, [34](#)
B4622B toolset, [34](#)
B4661A-1FP, [53](#)
B4661A-3FP, [17](#), [53](#), [136](#)
B4661A-4FP, [53](#)
bake, [141](#)
bend radius, [25](#), [27](#), [30](#), [47](#), [49](#)

C

cable connections, [71](#), [80](#), [94](#), [106](#), [116](#), [126](#)
characteristics, [139](#)
China RoHS, [144](#)
cleaning instrument, [143](#)
cleaning, interposer, [141](#)
configuration files, [136](#)
configuration files, saving, [137](#)

D

DDR Eyefinder, [17](#), [34](#), [53](#)
DDR Setup Assistant, [17](#), [34](#), [53](#)
DDR3 probes, [3](#)
DDR5 signals, [13](#)
dimensions, [18](#), [42](#), [55](#)
dimensions, W4631A interposer, [40](#)
dimensions, W4633A interposer, [36](#)
dimensions, W4636A interposer, [42](#)
dimensions, W4641A interposer, [58](#)
dimensions, W4643A interposer, [55](#)
dimensions, W5643A interposer, [18](#)
DRAM package, [25](#), [27](#), [30](#), [47](#), [49](#)

E

E5847A, [32](#)
E5849A, [31](#)
E5849A channel mapping, [85](#), [99](#), [100](#), [110](#), [120](#), [130](#)
equipment required, [17](#), [34](#), [53](#)

F

feature summary, [25](#), [27](#), [30](#), [49](#)

G

Grypper socket, [89](#)

H

humidity indicator, [141](#)

I

in this guide, [3](#)
installing the W4631A interposer, [87](#)
installing the W4633A interposer, [77](#), [113](#)
installing the W4636A interposer, [103](#), [123](#)
interposer, inputs to, [140](#)
interposer, outputs from, [140](#)
introduction, [23](#), [45](#)

K

keep-out volume, W4631A, [40](#), [59](#)
keep-out volume, W4633A, [37](#)
KOV, [42](#), [56](#)
KOV, W5643A, [21](#)

L

logic analysis system set up, [133](#)
logic analyzer cable, [33](#)
logic analyzer channel mapping, [84](#), [98](#), [109](#), [120](#), [130](#)
logic analyzer connections, [72](#), [84](#), [97](#), [109](#), [119](#), [129](#)

M

mechanical considerations, [18](#), [36](#), [55](#)

O

operating characteristics, [140](#)

P

pin 1, [90](#)
pinout, [73](#), [82](#), [95](#), [107](#), [117](#), [127](#)
probe cable, [31](#), [32](#)

R

regulatory information, [139](#)
regulatory notices, [144](#)
required probes, cables, LA modules, [17](#), [34](#), [54](#)
rework facilities, [61](#)
riser, [21](#), [26](#), [28](#), [37](#), [40](#), [48](#), [50](#), [56](#), [59](#), [63](#), [79](#), [89](#), [115](#)

S

safety, [142](#)
Safety Considerations, [142](#)
safety information, [139](#), [142](#)
safety symbols, [143](#)
safety warnings, [142](#)
setup, W5633A interposer, [67](#)
shelf life, [141](#)
signals not probed, [85](#), [101](#), [110](#), [121](#), [131](#)
soldering guidelines, [61](#)
soldering processes, [63](#)
soldering temperature, [63](#)
storage guidelines, [141](#)
symbols, safety, [143](#)

U

U4201A, [33](#), [84](#)
U4208A, [15](#), [16](#), [51](#), [52](#)

W

W4631A, [27](#)
W4631A interposer setup, [97](#)
W4631A KOV, [40](#), [59](#)
W4633A, [25](#), [47](#)
W4633A interposer setup, [84](#)
W4633A KOV, [37](#)
W4636A, [29](#)
W4636A interposer setup, [109](#)
W4641A, [49](#)
W4643A feature summary, [47](#)
W4643A KOV, [56](#)
W5643A, [12](#)
W5643A and cable orientation, [71](#)
W5643A bend radius, [13](#)
W5643A channel mapping, [75](#)
W5643A feature summary, [13](#)
W5643A KOV, [21](#)

W5643A logic analyzer channel
mapping, [75](#)
W5643A overview, [11](#)
W5643A pinout, [73](#)
W5643A riser, [14](#)
W5643A soldering, [69](#)
WEEE compliance, [144](#)

