

B40/B20 Patient Monitor

User's Guide



English
2081499-002 E (Paper)
21 November 2014
© 2014 General Electric Company.
All rights reserved.

B40/B20 Patient Monitor

User's Guide

Related to software VSP-C



All specifications are subject to change without notice.

Document no. 2081499-002 E

21 November 2014

GE Medical Systems Information Technologies, Inc.
8200 West Tower Avenue
Milwaukee, WI USA
Zip: 53223
Tel: +1 414 355 5000 (outside US)
800 558 5102 (US only)
Fax: +1 414 355 3790
www.gehealthcare.com

GE Healthcare
3F Building 1, GE Technology Park
1 Huatuo Road
Shanghai PRC 201203
Tel: +86 21 3877 7888
Fax: +86 21 3877 7451

Copyright © 2014 General Electric Company. All rights reserved.

Contents

About this manual	1	Impedance respiration	79
About this device	3	Pulse oximetry (SpO ₂)	83
Safety precautions	7	Non-invasive blood pressure (NIBP)	89
System introduction	9	Invasive blood pressure	95
Symbols	17	Temperature	101
Monitoring basics	21	Airway gas	103
Setting up the monitor before use	29	Entropy	115
Alarms	37	Troubleshooting	121
Starting and ending	47	Messages	124
Trends and Snapshot	51	Abbreviations	129
Printing and recording	55	Technical specifications	135
Cleaning and care	59	Electromagnetic Compatibility	149
ECG	67		
Pacemaker detection	73		
Arrhythmia detection	75		
ST Detection	77		

About this manual

This manual contains instructions necessary to operate this device in accordance with its functions and intended use. Descriptions refer to the software VSP-C

Information which refers only to certain versions of the product is accompanied by the model number(s) of the product(s) concerned. The model number is given on the nameplate of the product.

All illustrations in this manual are provided as examples only. They may not necessarily reflect your monitoring setup or data displayed on your monitor.

Manual conventions

Within this manual, special styles and formats are used to distinguish between terms viewed on screen, a button you must press, or a list of menu commands you must select:

- Names of hardware keys on the keypad are written in **bold** typeface: **NIBP Start/Cancel**.
- Menu items are written in **bold italic** typeface: ***Monitor Setup***.
- Emphasized text is in *italic* typeface.
- When referring to different sections in this manual, section names are enclosed in double quotes: “Cleaning and care”.
- The word “select” means choosing and confirming.
- Messages (alarm messages, informative messages) displayed on the screen are written inside single quotes: '**Learning**'.
- Note statements provide application tips or other useful information.

Monitor naming conventions

In this manual, the B40 Patient Monitor and B20 Patient Monitor are referred to as “the monitor” when a function or a feature applies to both. For describing monitor-specific issues, the monitors are referred to as B40 and B20 respectively.

Acquisition module naming conventions

In this manual, the following naming conventions are used to refer to different modules and module categories:

- Single-width airway module: E-miniC
- CARESCAPE respiratory modules: E-sCO, E-sCAiO
- Airway Gas Option: N-CAiO
- E-modules: All modules with the prefix E-, In parameter chapters, E-modules refers to those modules that measure the parameter(s) in question.
- Hemo: Hemodynamic

Illustrations and names

This manual uses illustrations as examples only. Illustrations in this manual may not necessarily reflect all system settings, features, configurations, or displayed data.

Names of persons, institutions, and places and related information are fictitious; any similarity to actual persons, entities, or places is purely coincidental.

Related documents

All publications conform with the product specifications and applicable IEC publications on safety and essential performance of electromedical equipment as well as with applicable UL and CSA requirements valid at the time of printing.

- Clinical aspects, basic methods of measurement and technical background: B40/B20 Patient Monitor User Reference Manual
- Installation, technical solutions and servicing: B40/B20 Patient Monitor Technical Reference Manual
- Options and selections of the software: B40/B20 Patient Monitor Default Configuration Worksheet
- Compatible supplies and accessories: B40/B20 Patient Monitor Supplies and Accessories
- Other devices closely related to the monitor:
 - iCentral and iCentral Client User's Reference Manual
 - CIC Pro Clinical Information Center Operator's Manual
 - CARESCAPE Central Station User's Manual

Ordering manuals

A paper copy of this manual will be provided upon request. Contact your local GE representative and request the part number on the first page of the manual.

About this device

Indications for use: B40

This device is a portable multi-parameter unit to be used for monitoring and recording of, and to generate alarms for, multiple physiological parameters of adult, pediatric, and neonatal patients in a hospital environment and during intra-hospital transport.

The device is intended for use under the direct supervision of a licensed health care practitioner.

The device is not intended for use during MRI.

The device can be a stand-alone monitor or interfaced to other devices via a network.

The device monitors and displays : ECG (including ST segment, arrhythmia detection), invasive blood pressure, heart/pulse rate, oscillometric non-invasive blood pressure (systolic, diastolic and mean arterial pressure), functional oxygen saturation (SpO₂) and pulse rate via continuous monitoring(including monitoring during conditions of clinical patient motion or low perfusion), temperature with a reusable or disposable electronic thermometer for continual monitoring Esophageal/Nasopharyngeal/Tympanic/Rectal/Bladder/Axillary/Skin/Airway/Room/Myocardial/Core/Surface temperature, impedance respiration, respiration rate, airway gases (CO₂, O₂, N₂O, anesthetic agents, anesthetic agent identification and respiratory rate), and Entropy.

Indications for use: B20

This device is a portable multi-parameter unit to be used for monitoring and recording of, and to generate alarms for, multiple physiological parameters of adult, pediatric, and neonatal patients in a hospital environment and during intra-hospital transport.

The device is intended for use under the direct supervision of a licensed health care practitioner.

The device is not intended for use during MRI.

The device can be a stand-alone monitor or interfaced to other devices via a network.

The device monitors and displays oscillometric non-invasive blood pressure (systolic, diastolic and mean arterial pressure), invasive blood pressure, end-tidal carbon dioxide, heart/pulse rate, respiration rate, ECG (including arrhythmia and ST segment analysis), temperature with a reusable or disposable electronic thermometer for continual monitoring Esophageal/Nasopharyngeal/Tympanic/Rectal/Bladder/Axillary/Skin/Airway/Room/Myocardial/Core/Surface temperature, and functional oxygen saturation (SpO₂) and pulse rate via continuous monitoring, including monitoring during conditions of clinical patient motion or low perfusion, and Entropy.

Service

If the product malfunctions or if assistance, service, or spare parts are required, contact GE service for technical support or contact your local representative. It is helpful for you to duplicate the problem, check and confirm the operation of all accessories to ensure that they are not the cause of the problem.

Training requirements

No product-specific training is required for the use of this monitor.

Trademarks

Listed below are GE Medical Systems *Information Technologies* and GE Healthcare Finland Oy trademarks used in this document. All other product and company names contained herein are the property of their respective owners.

Datex, Ohmeda, DINAMAP, Trim Knob, Unity Network, CARESCAPE, EK-Pro, TruSignal, Entropy, GE Healthcare, GE Medical system, General Electric Company.

Responsibility of the manufacturer

GE Medical Systems *Information Technologies*, Inc. is responsible for the safety, reliability and performance of the equipment only if:

- Assembly operations, extensions, readjustments, modifications, or repairs are carried out by persons authorized by GE.
- The electrical installation of the relevant room complies with the requirements of the appropriate regulations.
- The equipment is used in accordance with the instructions for use.
- The equipment is installed, maintained and serviced in accordance with the instructions provided in the related technical manuals.

Product availability

Some of the products mentioned in this manual may not be available in all countries. Please consult your local representative for the availability.

Classifications

In accordance with IEC 60601-1:

- Class I and internally powered equipment - the type of protection against electric shock.
- Type BF or CF equipment. The degree of protection against electric shock is indicated by a symbol on each parameter module.
- Equipment is not suitable for use in the presence of a flammable anesthetic mixture with air or with oxygen or nitrous oxide.
- Continuous operation according to the mode of operation.
- Portable Monitor

In accordance with IEC 60529:

- IP21 - degree of protection against harmful ingress of water.

In accordance with EU Medical Device Directive:

- IIb

In accordance with CISPR 11:

- Group 1 Class A;
 - Group 1 contains all ISM (Industrial, scientific and medical) equipment in which there is intentionally generated and/or used conductively coupled radio-frequency energy which is necessary for the internal functioning of the equipment itself.
 - Class A equipment is equipment suitable for use in all establishments other than domestic and those directly connected to a low-voltage power supply network which supplies buildings used for domestic purposes.

CE marking information

CE compliance

The monitor bears CE Mark CE-0459 indicating its conformity with the provisions of the Council Directive 93/42/EEC concerning medical devices amended by 2007/47/EC and fulfills the essential requirements of Annex I of this directive. The country of manufacture can be found on the equipment labeling.

Product Compliance

- This equipment is suitable for connection to public mains as defined in CISPR 11.
- This Monitor conforms to general safety standard for medical devices to IEC 60601-1.
- This Monitor conforms to EMC safety standard to IEC 60601-1-2.
- This Monitor conforms to usability safety standard for medical devices to IEC 60601-1-6.
- The application of usability engineering to medical device conforms to IEC 62366.
- The software life cycle processes conforms to IEC 62304.
- The application of risk management analysis to medical device conforms to ISO 14971.
- The SpO2 Parameter conforms to ISO 80601-2-61.
- The SpO2 Parameter controlled desaturation study conforms to ISO 14155: 2011.
- The TEMP parameter conforms to ISO 80601-2-56.
- The gas parameter conforms to ISO 80601-2-55.
- This Monitor conforms to particular safety standard for multifunction patient monitoring equipment to IEC 60601-2-49.
- The invasive blood pressure parameter conforms to the IEC 60601-2-34.
- The ECG parameter conforms to IEC 60601-2-27, with exception of Sub-clause 201.12.1.101.15.
- The NIBP parameter conforms to IEC 80601-2-30, EN 1060-3, ANSI/AAMI/ISO 81060-2.
- The Entropy parameter conforms to IEC 60601-2-26.
- The alarm systems of the Monitor conform to IEC 60601-1-8.

Exception

The ECG parameter conforms to IEC 60601-2-27, with exception of Sub-clause 201.12.1.101.15 QRS detection.

WARNING: In clinical conditions, it is reasonable to assume that spurious signals of this type are either random in occurrence, or related to pacemaker activity. The arrhythmia analysis algorithm is designed to factor the randomness of spikes into its rejection logic, and this randomness is not exercised in the above referenced testing. The algorithm does correctly reject pace signals as prescribed by IEC 60601-2-27.

Safety precautions

These safety messages refer to the entire system. The message specific to parts of the system can be found in the relevant section.

Safety message signal words

Safety message signal words designate the severity of a potential hazard.

Danger	Indicates a hazardous situation that, if not avoided, will result in death or serious injury.
Warning	Indicates a hazardous situation that, if not avoided, could result in death or serious injury.
Caution	Indicates a hazardous situation that, if not avoided, could result in minor or moderate injury.
Notice	Indicates a hazardous situation not related to personal injury that, if not avoided, could result in property damage.

Danger safety messages

No danger safety messages apply to this monitoring system.

Warning safety messages

The following warning safety messages apply to this monitoring system.

- Read all the safety information before using the monitor for the first time.
- Equipment is intended for clinical professionals.
- For continued safe use of this equipment, it is necessary that the listed instructions are followed. However, instructions listed in this manual in no way supersede established medical practices concerning patient care.
- Single-use devices and accessories are not designed to be reused. Reuse may cause a risk of contamination, affect the measurement accuracy and/or system performance, and cause

a malfunction as a result of the product being physically damaged due to cleaning, disinfection, re-sterilization and/or reuse.

- There are hazards associated with the reuse of single-use sample tubing and adapters
- Inspect the sensor for signs of physical damage. Discard a damaged sensor immediately. Never repair a damaged sensor; never use a sensor repaired by others.
- Do not sterilize or immerse the sensor or cable in liquid. Do not spray or soak the connectors.
- Do not route cables in a way that presents a tripping hazard.
- Route all cables away from patient's throat to avoid possible strangulation.
- Do not touch the patient, table, instruments, modules or the monitor during defibrillation.
- To avoid the risk of electric shock, this equipment must only be connected to a supply mains with protective earth.
- Always check that power cord and plug are intact and undamaged.
- Use only approved accessories, including mounts, and defibrillator-proof cables and invasive pressure transducers. For a list of approved accessories, see the supplies and accessories list delivered with the monitor. Other cables, transducers and accessories may cause a safety hazard, damage the equipment or system, result in increased emissions or decreased immunity of the equipment or system or interfere with the measurement.
- DISCONNECTION FROM MAINS - When disconnecting the system from the power line, remove the plug from the wall outlet first. Then you may disconnect the power cord from the device. If you do not observe this sequence, there is a risk of coming into

contact with line voltage by inserting metal objects, such as the pins of leadwires, into the sockets of the power cord by mistake.

- If liquid has accidentally entered the system or its parts, disconnect the power cord from the power supply and have the equipment serviced by authorized service personnel.
- If a service message appears, discontinue use as soon as possible and have the device repaired.
- PROTECTED LEADWIRES - Only use protected leadwires and patient cables with this monitor
- When applying devices intracardially, never contact electrically conductive parts connected to the heart (pressure transducers, metal tube connections and stopcocks, guide wires, etc.).
- Do not use the monitor in high electromagnetic fields (e.g., MRI).
- Do not tilt the monitor to avoid liquid entering.
- Do not touch the electrical connector located within the extension rack housing.
- Never store the monitor with the batteries inside. Storing the monitor with the batteries inside may result in damage to the monitor.
- NETWORK INTEGRITY — The monitor resides on the CARESCAPE, S/5 and/or HL7 network. It is possible that inadvertent or malicious network activity could adversely affect patient monitoring. The integrity of the network is the responsibility of the hospital.
- Don't modify this device without authorization of manufacturer. If this device is modified, appropriate inspection and testing must be conducted to ensure continued safe use of equipment.

Caution safety messages

The following caution safety messages apply to this monitoring system.

- U.S. Federal law restricts this device to sale by or on the order of a physician.
- SUPERVISED USE - This equipment is intended for use under the direct supervision of a licensed health care practitioner.
- Dispose of equipment in compliance with instructions and regulations.
- Reset the monitor if loss of monitoring data occurs.
- Leave space for circulation of air to prevent the monitor from overheating.
- Before connecting power, check voltage and frequency ratings of equipment.
- System time changes will result in time differences between stored and realtime data.

Notice safety message

The following notice safety messages apply to this monitoring system.

- NOTICE - The warranty does not cover damages resulting from the use of accessories and consumables from other manufacturers.
- If the device has been transported or stored outside operating temperature allow the device stabilize back to operating temperature range before applying power.
- The equipment is suitable for use in the presence of electrosurgery. Please notice the possible limitations in the parameter sections and in the "Technical specification" section.

System introduction

Safety precautions

Warnings

- All system devices must be connected to the same power supply circuit
- EXCESSIVE LEAKAGE CURRENT - Do not use a multiple socket outlet or extension cord.
- INTERFACING OTHER EQUIPMENT - Devices may only be interconnected with each other or to parts of the system when it has been determined by qualified biomedical personnel that there is no danger to the patient, the operator, or the environment as a result. In those instances where there is any element of doubt concerning the safety of the connected devices, the user must contact the manufacturers concerned (or other informed experts) for proper use. In all cases, safe and proper operation should be verified with the applicable manufacturer's instructions for use, and system standards IEC 60601-1 must be complied with.
- The medical electrical equipment or medical electrical system may be interfered with by other equipment, even if that other equipment complies with CISPR EMISSION requirements.
- BEFORE INSTALLATION — Compatibility is critical to safe and effective use of this device. Please contact your local sales or service representative prior to installation to verify equipment compatibility.

System components

NOTE: Your system may not include all these components. Consult your local representative for the available components.

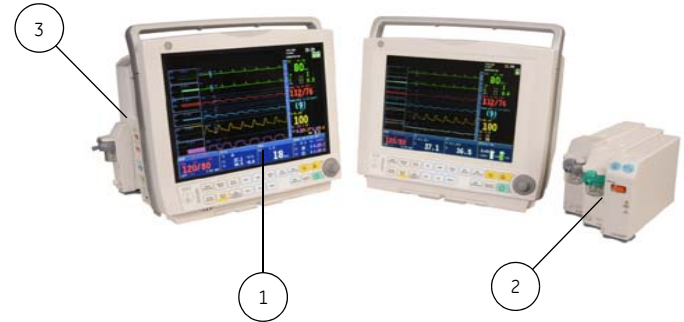

1. **Monitor frame with Software:** VSP-C
2. **E-modules:** Parameter acquisition modules
3. **Extension rack**

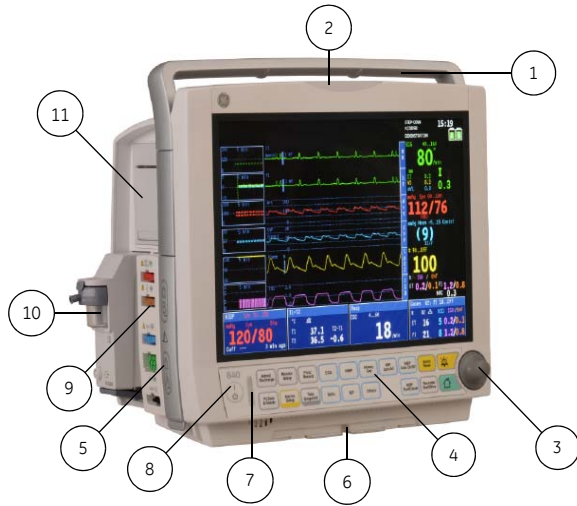
Frame front view
**B40 Front view****B20 Front view**

1. Transportation handle
2. Alarm light
3. Trim knob
4. Command board keys
5. Battery compartment
6. Guide rail for GCX mounting
7. Mains power and battery LEDs
8. On/Off key
9. Hemo connectors
10. E-module
11. Recorder module

Frame back view

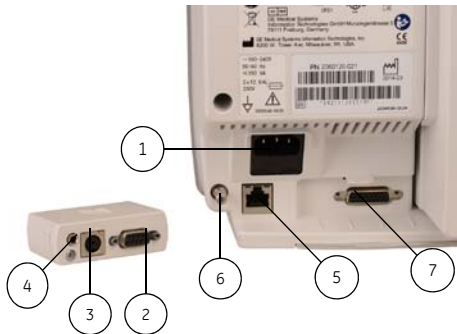

Input/Output adapter and connectors



B40 back view



B20 back view

1. Receptacle for power cord
2. Serial port
3. Defibrillator connector
4. Nurse call connector
5. Network connector
6. Equipotential connector
7. Multi I/O connector

NOTE: 2,3,4 is on the multiple Input/Output adapter.

Acquisition modules

B40 acquisition modules:

- E-miniC
- E-sCO, E-sCAiO
- N-CAiO
- E-Entropy

B20 acquisition modules:

- E-miniC
- E-Entropy

E-miniC module



1. Water trap
2. Sample gas inlet
3. Gas outlet

E-sCO, E-sCAiO module



E-sCAiO

E-sCO

1. D-fend Pro water trap
2. Gas sampling line connector (sampling gas in)
3. Water trap container
4. Gas exhaust line connector (sampling gas out)

N-CAiO module

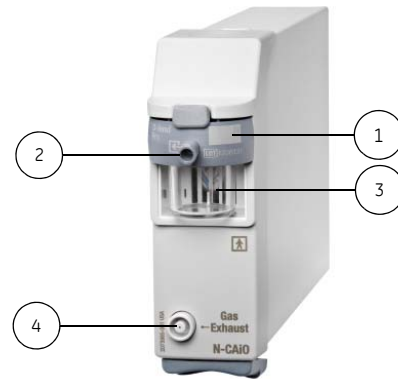

1. D-fend Pro water trap
2. Gas sampling line connector (sampling gas in)
3. Water trap container
4. Gas exhaust line connector (sampling gas out)

E-Entropy module

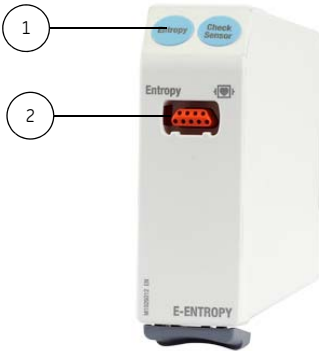

1. Module keys
2. Entropy connector

How to identify the Hemo connectors' configuration

The monitor provides different configurations for Hemo measurement.

The user can identify Hemo connectors' configuration from connectors and label.

Hemo connectors' type	Basic feature			Optional feature		Identifier
	ECG	NIBP	SpO ₂	IBP	Temperature	
Hemo with GE SpO ₂	X	X	GE SpO ₂	X	X	SpO2_IBP_T
Hemo with Masimo SpO ₂	X	X	Masimo SpO ₂	X	X	MasimoSpO2_IBP_T
Hemo with Nellcor SpO ₂	X	X	Nellcor SpO ₂	X	X	NellcorSpO2_IBP_T
Hemo with GE SpO ₂ , without IBP	X	X	GE SpO ₂		X	SpO2_T
Hemo with Masimo SpO ₂ , without IBP	X	X	Masimo SpO ₂		X	MasimoSpO2_T
Hemo with Nellcor SpO ₂ , without IBP	X	X	Nellcor SpO ₂		X	NellcorSpO2_T
Hemo with GE SpO ₂ , without IBP and Temp	X	X	GE SpO ₂			SpO2

Command board keys

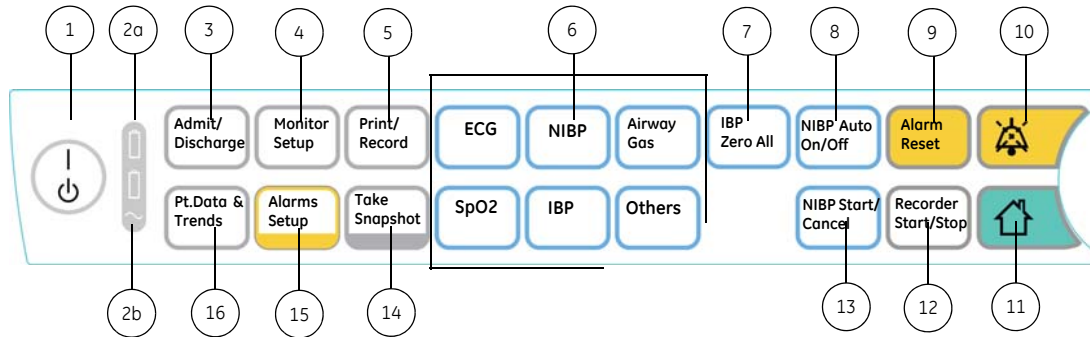

- (1) ON/OFF key
- (2a) Battery status LED (light-emitting diode), see ["Battery indicators" on page 26](#) for details
- (2b) AC power status LED
- (3) Admit or discharge a patient; select user modes, see ["Using modes" on page 32](#)
- (4) Monitor settings
- (5) Print and record different trends and waveforms
- (6) Activate parameter specific menus
- (7) Zeros invasive pressure channels
NOTE: Functional only when IBP option is available
- (8) Start or stop NIBP auto cycling
- (9) Reset active alarms

- (10) Audio pause active alarms
- (11) Return to normal screen view
- (12) Start or stop local recording
NOTE: Functional only when recorder option is available
- (13) Start or stop the NIBP manual measurement
- (14) Take up to 10 snapshots, see ["Take snapshots" on page 53](#)
- (15) Activate the **Alarms Setup** menu
- (16) View historical trends and alarm events

Symbols



- On the rear panel:
 - Electric shock hazard. Do not open the front or back cover. Servicing of the product should be performed only by qualified service personnel.
 - For continued protection against fire hazard, replace the fuse only with one of the same type and rating.
 - Disconnect from the power supply before servicing.
 - Do not use without manufacturer approved mounting.
- On the hemo module this symbol indicates the following warning: Protection against cardiac defibrillator discharge is due in part to the accessories for pulse oximetry (SpO₂), temperature (T) and invasive pressure (P) measurement.



Consult operating instructions. / Operating instructions.



Refer to instruction manual/booklet about operation.



Electrostatic sensitive device. Connections should not be made to this device unless ESD precautionary procedures are followed.



Type BF (IEC 60601-1) protection against electric shock. Isolated (floating) applied part suitable for intentional external and internal application to the patient, excluding direct cardiac application.



Type BF (IEC 60601-1) defibrillator-proof protection against electric shock. Isolated (floating) applied part suitable for intentional external and internal application to the patient, excluding direct cardiac application.



Type CF (IEC 60601-1) protection against electric shock. Isolated (floating) applied part suitable for intentional external and internal application to the patient, including direct cardiac application.



Type CF (IEC 60601-1) defibrillator-proof protection against electric shock. Isolated (floating) applied part suitable for intentional external and internal application to the patient including direct cardiac application.



Audio alarms off indicator - Displays in the upper left corner of the alarm area when physiological audible alarms are turned off.



Alarm off indicator - Displays in the digit field and in the **Alarms Setup** menu when physiological alarms for this parameter are turned off.



On the screen:

Audio alarms paused indicator - Indicates all audio alarms are paused and the amount of time remaining for the alarm pause period displays as a countdown timer. Displays in the upper left corner of the screen.



In the front panel: battery.



Equipotentiality. Monitor can be connected to potential equalization conductor.



Alternating current.



On the keypad:
Bell cancel. Audio pause.



Home. Return to the normal screen view.



ON/OFF.



Fuse.



Gas inlet.



Gas outlet.

Degree of ingress protection.

Degree of protection against harmful ingress of water:

IP21

Components not marked with and IPX n code are rated as Ordinary (no protection against fluid ingress). All other IPXn rated components have the degree of protection per the 'n' rating.

SN,S/N

Serial number.



Date of manufacture. This symbol indicates the date of manufacture of this device. The four digits identify the year.



Manufacturer: This symbol indicates the name and the address of the manufacturer.



European authorized representative.



European Union Declaration of Conformity.



Underwriters Laboratories product certification mark. Medical Equipment with respect to electrical shock, fire and mechanical hazards only in accordance with ANSI/AAMI ES60601-1:2005/(R)2012 and A1:2012, C1:2009/(R)2012 and A2:2010/(R)2012; CSA CAN/CSA-C22.2 NO. 60601-1:14; IEC 60601-2-26; IEC 60601-2-27; IEC 80601-2-30; IEC 60601-2-34; IEC 60601-2-49; ISO 80601-2-55; ISO80601-2-56; ISO80601-2-61

Rx Only U.S.

Prescriptive Device. USA only. For use by or on the order of a Physician, or persons licensed by state law.



Fragile. Handle with care.



Keep dry. Protect from rain.



This way up.



Storage temperature



Humidity limitations.



Atmospheric pressure limitations.



Recycled materials or may be recycled.



Battery operation and remaining capacity. The height of the green bar indicates the charging level.



Battery (A) charging (white bar)



Battery (A) failure



No battery backup



Battery (A) missing



SubMenu. Selecting a menu item with this symbol opens a new menu.



The monitor is connected to Network via LAN.



A blinking heart next to the heart rate or pulse rate value indicates the beats detected.



Respiration indicator. Indicates a breath is detected by the impedance respiration algorithm.



This symbol indicates that the waste of electrical and electronic equipment must not be disposed as unsorted municipal waste and must be collected separately. Please, contact an authorized representative of the manufacturer for information concerning the decommissioning of your equipment.

The separate collection symbol is affixed to a battery, or its packaging, to advise you that the battery must be recycled or disposed of in accordance with local or country laws. To minimize potential effects on the environment and human health, it is important that all marked batteries that you remove from the product are properly recycled or disposed. For information on how the battery may be safely removed from the device, please consult the service manual or equipment instructions. Information on the potential effects on the environment and human health of the substances used in batteries is available at this url: <http://www.gehealthcare.com/euen/weee-recycling/index.html>

Monitoring basics

Warnings

- Ensure modules are oriented with release latch downward to ensure retention.
- The parameter modules are not able to withstand unpacked drops from a height of 1 m without damaging the module latches. If the device is dropped, please service the device before taking it back into use.
- After transferring or reinstalling equipment, always check that equipment is properly connected and parts are securely attached.
- Do not use without manufacturer approved mounting.
- Do not install equipment above the patient.
- Be careful not to drop modules while detaching.
- Do not touch the back of frame enclosure in normal use.

Cautions

- Do not drop battery or subject to mechanical shock.
- Use only the recommended batteries.
- Malfunction may cause gases to vent.
- SAFETY GROUND PRECAUTION - Remove power cord from the mains source by grasping the plug. DO NOT pull on the cable.

Inserting and removing acquisition modules

To use the acquisition module, your monitoring device need to be pre-configured with the extension rack.



To insert module:

1. Align the module with the insertion guides.
2. Push the module into the monitor frame until it clicks and stops.
3. Pull the module outwards to insure the module is firmly seated.

To remove module

1. Pressing the release latch on the bottom lefthand side of the module.
2. Grasp the module firmly and pull out of the Frame. Ensure not to drop the module during removal.

Main screen layout

The main screen displays alarms, trends, waveforms, digits, and the main menu in pre-defined areas.

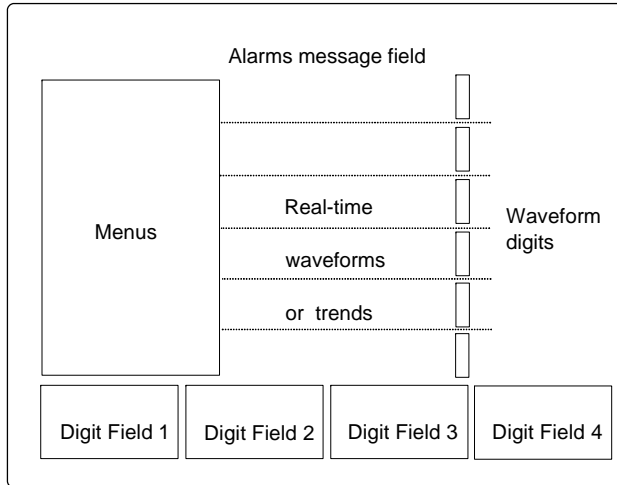

At startup, the screen is arranged according to the startup mode definitions. You can decide which waveforms and numerical information are displayed, and where on the screen they are arranged. You can do this during monitoring or save the changes in the user mode. Please refer to Chapter ["Setting up the monitor before use"](#) for more details.

Using menus

A menu is a list of functions or commands. To display a menu, press one of the keypad keys.

To select menu options with **Trim Knob** control:

1. Rotate the **Trim Knob** control in either direction to move the highlighted cursor from option to option on the display.
2. Press the **Trim Knob** control once to select the highlighted option.

Network

Warnings

- Do not use with iCentral software V5.0.3 and earlier.
- Do not use Mobile Care Server software V5.2 and earlier.

Caution

- Install HL7 network interfaces as specified, and only by qualified personnel.

The monitor has been verified to be able to work in CARESCAPE* Network and S/5 network environments. Other network infrastructures are not supported.

The monitor has EMR connectivity. There are three ways to acquire trended vital sign data from patient monitor: HL7 directly from monitor, HL7 from the CARESCAPE Gateway, or connecting to the serial port of each monitor. The monitor HL7 (Health Level Seven) message match with IHE PCD-01 OBR/OBX format.

On the CARESCAPE network, the monitor is able to:

- communicate with GE CARESCAPE CIC pro version 4.0.8, 4.1.1 and 5.1.0
- communicate with GE CARESCAPE Central Station v1
- compatible with Aware Gateway Server v1.6
- compatible with CARESCAPE Gateway server v1.
- compatible with Mobile Care Server v6.0
- compatible with S/5 Collect v4.0

On the CARESCAPE network, the bedside monitor can simultaneously communicate with a maximum of 4 central stations, 1 Gateway server, 1 Mobile Care Server and up to 1,000 other monitoring devices. The bedside monitor cannot be the Time Master on the CARESCAPE network.

On the S/5 network, the monitor is able to:

- communicate with iCentral version 5.1.1 and 5.1.2.
- compatible with S/5 Collect v4.0
- compatible with Mobile Care Server v6.0

The monitor does not support the Patient Data Server (PDS). The monitor's realtime patient data can't be viewed on other monitors (e.g. Dash 3000/4000/5000, Solar 8000, B850, B650).

The following monitoring information is transferred to the central station:

- Supported parameters
- Real-time waveforms
- Real-time alarms
- Arrhythmia alarms: Asystole, VFib, VTach, Brady and Tachy
- Graphic and numeric trends
- Admit/discharge status
- Patient demographic information
- Alarm settings

Additionally, on the CARESCAPE network, the monitor supports remote parameter and waveform configurations from the central station.

NOTES:

- The Entropy parameter is not supported by CIC pro and CARESCAPE Central station.
- On the iCentral, the care area settings can be setup to "Non OR" or "OR" in the DRI service menu. Please consult the authorized service personnel.

Non OR:

- Displays up to 72 hours of trend data.
NOTE: Anesthesia Gas trends are not supported
- Does not display Entropy alarm limits

OR:

- Displays up to 24 hours of trend data

Connection to Network

Ensure that the appropriate network infrastructure is in place prior to the installation of the patient monitor.

NOTE: The network installation and configuration are performed by authorized service personnel only.

MC and S/5 Network

Use the CAT-5 network cable to connect the monitor to the network.

1. Make sure that the power is switched off.
2. Connect one RJ-45 connector to the network port at the back of the monitor.
3. Connect the other RJ-45 connector to the corresponding port on the wall.
4. Turn on the power. Confirm that the network symbol and 'Network: xxx' message are displayed.



Batteries

Warnings

- EXPLOSION OR FIRE-Using non-recommended batteries could result in injury/burns to the patients or users. Only use batteries recommended or manufactured by GE.
- EXPLOSION HAZARD - not suitable for use in the presence of a flammable anaesthetic mixture with air or with oxygen or nitrous oxide
- EXPLOSION HAZARD - Do not incinerate the battery or store at high temperatures
- Do not disassemble, open, or shred the battery; do not short circuit the battery pack; charge only with internal charger

The monitor supports up to two lithium-ion batteries. Each battery can be charged separately. During charging, screen symbols and monitor frame LEDs indicate the current charging level and any possible failures. You can check the battery status through **Monitor Setup - Battery Setup**. For additional information please refer to the table following this statement.









The battery should be used if the integrity of the PROTECTIVE EARTH CONDUCTOR in the installation is in doubt.

To configure to have the battery charge status visible at all time, follow the following steps: **Monitor Setup - Screen Setup - Digit Fields - Battery**.

NOTE: When the monitor is battery powered, the green battery LED is on. When the monitor is connected to the mains power, the green mains LED is on. See also sections "[Conditioning the batteries](#)" and "[Messages](#)."

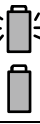
NOTE: If batteries are installed and the monitor is disconnected from the mains power, it will automatically switch to battery power without interruption of operation.

Battery indicators

Screen	Explanation	Front panel battery LEDs
	Monitor is battery powered. Batteries are fully charged; the size of the green bar indicates the charging level.	Orange dark Green lit 
	Monitor is battery powered. Battery A is empty, battery B charge is partially charged.	Orange dark Green lit 
	Monitor is battery powered. Battery A failure, battery B is full.	Orange flashing Green lit 
NOTE: If both batteries fail, the green battery LED is dark.		
	Monitor is mains powered. Battery A is being charged (white bar), battery B is already charged.	Orange lit Green dark 
	No battery is in the monitor.	Orange dark Green dark 

Checking the battery charge when the monitor is turned off

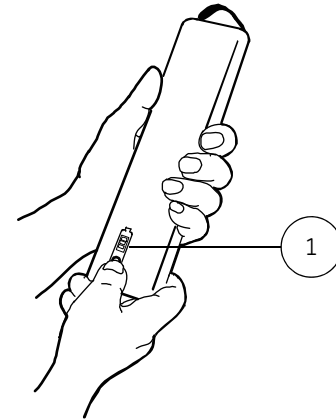

When the monitor is turned off, you can check the battery charged level by pressing the test button on the battery, as indicated in the drawing. The charging indicator bar (1) lights up and the number of illuminated segments indicates the current charge level.

CAUTION: Do not dismantle the battery.

Replacing the batteries

Battery capacity indicators in the upper right corner of the screen indicate when a battery needs to be replaced, charged, missing or not functional, see above table to additional information.

CAUTION: After replacing a battery, always make sure to close the battery compartment by sliding the lid back to the right until it clicks.



- (1) Open the cover of the battery compartment located on the side of the monitor. Move the latch up or down. Remove the desired battery.
- (2) Insert the new battery. Ensure that the battery charging indicator is facing to the back side of the monitor, then push the battery in all the way, move the latch to the middle and close the cover. Check the monitor indicators, see above.

Troubleshooting

- Battery operation time is markedly shortened:
 - Condition the batteries, see [“Conditioning the batteries”](#) and the “User’s Reference Manual.”
- The monitor does not start:
 - Check that the batteries are properly inserted and sufficiently charged, see page [25](#).
 - Check that the power cord is properly connected.
 - Check the fuses and replace them if necessary, see [“Cleaning and care.”](#)

Setting up the monitor before use

Warnings

- Operator should check the preset in use before use on each patient.
- A hazard can exist when using differing presets on like devices in a common area. For instance, two beside monitors used in an ICU with different presets may present a hazard.

NOTE: For more information about the installation settings and user modes, see the "User's Reference Manual" and "Default Configuration Worksheet".

Passwords

NOTE: The advanced configuration menus require a password. For more information, please contact your local representative or hospital representative.

Modifying the screen setup

A graphic presentation of a generic layout can be found in the "Monitoring basics" chapter.

When monitoring starts, the main page appears automatically. This preconfigured page is called the normal screen. Any changes made to the screen setup during active monitoring are temporary, unless saved to a profile. All temporary changes will be discarded when the case ends or when the monitor is discharged.

NOTE: The temporary settings are retained in the monitor's memory for 15 minutes after the power is turned off.

Changing waveform fields

1. Press the **Monitor Setup** key.
2. Select **Screen Setup**.
3. Select **Waveform Fields**.

Up to six waveforms can be displayed at a time.

When waveforms are configured to be displayed, they will be displayed or removed automatically when a module and/or cables are connected or disconnected.

Waveforms are always evenly distributed to fill the entire waveform area. Whenever there are less than 6 waveforms configured on the screen, the remaining waveforms are enlarged.

Changing a displayed waveform to another waveform also will update the associated numerical field that is displayed to the right of the waveform.

NOTE: Depending on your configuration, if the same measurement in the waveform field that is currently in the digit field, the digit field disappears.

Selecting **Combine Pressures** in the **Waveform Fields** menu displays invasive pressures in the same waveform field with individual scales.

When using a 5-lead ECG cable, up to three different ECG leads can be displayed simultaneously in different fields.

Changing digit fields

Patient numerical data is displayed in up to four digit fields, located in the lower part of the screen. The fields are numbered from left to right.

Each of the field can be edited or turn off. Before modifying the digit fields remember to check that the desired parameter module is plugged in.

1. Press the **Monitor Setup** key and select **Screen Setup**.
2. Select **Digit Fields** and change the field contents.

NOTE: Depending on your configuration, if the same measurement in the digit field that is currently in the waveform field, the waveform field disappears.

If a digit field is turned **OFF**, the remaining digit fields are enlarged to fill the space.

Changing split screen

To configure the normal screen to display both real-time data and Minitrend data, perform the following:

To select a split screen view:

1. Press the **Monitor Setup** key.
2. Select **Screen Setup**.
3. Select **Split Screen** and choose from the options: **Trend** or **None**

Changing the minitrend length

Minitrend data can be displayed next to the parameter waveform field in 5 or 30 minute intervals.

NOTE: 5 minute minitrends are updated every 10 seconds, and 30 minute minitrends are updated once a minute.

To modify the minitrend length:

1. Press the **Monitor Setup** key.
2. Select **Screen Setup**.
3. Select **Minitrend Length** and choose **5 min** or **30 min**.

Modifying other adjustable screen feature

Display brightness

1. Press **Monitor Setup** and select *Display brightness*.
2. Select from **10** to **100 %**.

Sweep speeds

You can change the speed of the waveforms on the screen.

- Hemodynamic and EEG waveform sweep speed options are **12.5**, **25** and **50 mm/s**.
- Other parameters, waveform sweep speed options are **Fast** (6.25 mm/s) and **Slow** (0.625 mm/s).

NOTE: If the sweep speed is set to Slow, the sweep speed is one tenth of a full screen sweep. Slow sweep speed waveforms show amplitude changes better than sweep speeds set to Fast.

1. Press the **Monitor Setup** key.
2. Select **Sweep Speeds**.
3. Select the parameter and adjust the value.

Parameter colors

Parameter color options include: yellow, white, green, red, blue, orange and violet. To change the color perform the following steps:

1. Press the **Monitor Setup** key.
2. Select **Install/Service** and enter the password.
3. Select **Colors**.
4. Select the desired parameter and the color.

Displaying pulse rate

Combined heart rate and pulse rate can be displayed next to the ECG waveform. The current HR source is displayed in larger font. A flashing heart symbol is displayed next to the HR value.

1. Press the **ECG** key.
2. Select **ECG Setup**.
3. Select **Display with HR** to **PR**, **PVC** or **None**.

Using modes

The monitor has seven user modes. These user modes are predefined combinations of settings. These user modes determine what is displayed on the screen, in trends and alarm settings.

User modes can also be customized and saved. The monitor starts in start-up mode, which is one of the user modes chosen during configuration. The default modes are **STEP-DOWN, ED, PACU, CCU, OR, PEDIATRIC, NEONATAL**. For more information about the default user modes, see the "Default Configuration Worksheet" delivered with the monitor.

Changing the startup mode

1. Select **Monitor Setup - Install/Service** (password).
2. Select **Save Modes** (password).
3. Select **Startup Mode - 1, 2, 3, 4, 5, 6** or **7**.

Changing the user modes

NOTE: If you want to make changes in user modes, we recommend you contact the person responsible for the configuration. When new settings are saved, they should be marked in the "Default Configuration Worksheet". See below for instructions on how to change the modes permanently.

1. Select the user mode you wish to change through **Admit/ Discharge - Select Mode**.
NOTE: You need select patient type to **NEO** through **Admit/ Discharge** first, if you want to select **NEONATAL** mode.
2. Make necessary changes (sweep speeds, parameter colors, report contents, screen setup, trends etc.). To change a parameter setup, press a parameter key and go to the setup menu. For instructions, see relevant parameter sections. To

change alarm limits and volume, press the **Alarms Setup** key. For instructions, see "**Alarms**."

3. Confirm changes through **Monitor Setup - Install/Service** (password) - **Save Modes** (password) - **Save**. You can save the changes also in other modes. If you do not save the changes in the modes, they are temporary and valid only until you discharge a patient or change the mode or until more than 15 minutes has elapsed from the turn-off of the monitor.

Renaming a mode

1. Select **Monitor Setup - Install/Service** (password).
2. Select **Save Modes** (password).
3. Select the mode, select **Name** and give a new name.

Loading modes

1. Select **Monitor Setup - Install/Service** (password).
2. Select **Save Modes** (password).
3. Select **Load Modes** and load to/from S/5 network.

NOTE: To active this option, monitors should be connected to network. Make sure the patient is discharge before you do above steps.

Setting trends

Changing default trend

You can select graphical or numerical trends to be displayed by default:

1. Press **Monitor Setup** key.
2. Select **Install/Service** and enter the password.
3. Select **Trends & Snapshot**.
4. Select **Default Trend** for **Graph** or **Num**.

Configuring trend pages

You can change the parameters on the trend fields:

1. Press **Monitor Setup** key.
2. Select **Install/Service** and enter the password.
3. Select **Trends & Snapshot** and select **Graphical Trends**
4. Select the trend page that you want to change
5. Select graphical parameters for each field. Field 1-5 can be displayed on screen and Field 6 can be printed.

NOTE: You can't make changes in numerical trend page configuration.

Configuring snapshots

You can change the snapshot settings,

1. Press **Monitor Setup** key.
 2. Select **Install/Service** and enter the password.
 3. Select **Trends & Snapshot**
 4. Select **Snapshot**
 - **Field 1 – Field 6:** Select to display waveform, graphical trend or numerical trend. Field 1-5 can be displayed on screen and Field 6 can be printed.
 - **Create on Alarms:** Select **YES** (default) to create automatic snapshots for Tachy, Brady, Art high, Art low alarms.
NOTE: If you need arrhythmia alarms to trigger snapshot, please set up in ECG arrhythmia alarms menu, [Selecting arrhythmia alarm for snapshots](#) on page 76.
 - **Automatic Print:**
 - **ALL** to print all the snapshots immediately after creation.
 - **ALARMS** to print snapshots created on alarms and arrhythmia alarms if create snapshot selected YES.
 - **NO** to print only on request.
- NOTE: Network laser printer only.

Setting trend lengths and scales

Press **Pt.Data & Trends**:

- Select **Trends - Graphical - Time Scale** and select the trend length.
- Select **Trends - Graphical - Trend Scales** and adjust the scales.

Setting time and date

NOTE: If the monitor is connected to the central station, it follows the central station's time settings and the **Time and Date** menu is not available.

NOTE: You cannot change the monitor's time settings after the patient has been admitted.

1. Press **Monitor Setup** and select **Time and Date**
2. Turn and push the Trim Knob to set the time and date.

Battery setup

Through this menu, you can check the battery status:

1. Press the **Monitor Setup** key.
2. Select **Battery Setup**. Battery information is now available.

Changing the monitor installation settings

Changing unit

You can change units for height, weight and blood pressure.

1. Press **Monitor Setup** key.
2. Select **Install/Service** and enter the password.
3. Select **Installation - Units**
4. Set the units for height, weight and blood pressure.

You can change temperature units through **Others - Temp Setup** and CO₂ units through **Airway Gas - CO2 Setup**. The changes are permanent.

Changing alarm options

1. Press **Monitor Setup** key.
2. Select **Install/Service** and enter the password.
3. Select **Installation - Alarm Options**.
 - **Show Limits:** Select **YES** to show alarm limits in digit fields. **YES** is the default.
 - **Show Audio ON/OFF:** Select **YES** to enable alarm audio off. Select **NO** (default) disables audio off option in the **Audio ON/OFF** menu in **Alarms Setup**.
 - **Latching Alarms:** Select **YES** to keep alarm messages on screen until **Audio pause** key or **Alarm Reset** key is pressed. **NO** is the default.
 - **Breakthrough Alarm:** Select **Off** to close breakthrough alarms feature, select **Pedi** to turn on breakthrough feature for new fatal alarms, select **Adult** to turn on breakthrough feature for new fatal alarms, excluding Brady.
 - **Min Alarm Volume:** Adjust minimum volume of audible alarm tone.
 - **Reminder Volume:** Adjust volume of audible alarm reminder tone.
 - **Alarm Tones:** Select **ISO**, **ISO2**, **General** or **IEC** tones.
 - **Remote Control:** Select **active** to enable alarm remote control by central station. **Inactive** is the default.

Changing the printer settings

1. Press **Monitor Setup** key.
2. Select **Install/Service** and enter the password.
3. Select **Installation - Printer**.
 - **Snapshot Printout:** Select **12.5** or **25 mm/s**
 - **Printer Connection:** Select **Net 1** to **Net 16/None** (default)
 - **Paper Size:** Select **A4** or **Letter**

NOTE: Network printer only.

Other printer settings can be changed in the **Record & Print** menu. For more information about the printing function, see the "[Printing and recording](#)" chapter.

Changing the parameter settings

1. Press **Monitor Setup** key.
2. Select **Install/Service** and enter the password.
3. Select **Installation - Monitor Settings - Parameter Settings**.
 - **CO2 Numbers:** Set CO₂ humidity compensation **Dry** or **Wet**.
 - **MAC Type:** Set MAC type **MAC** or **MACage** (B40 only)

Setting time zone

Time Zone menu is enable only when monitor is not connected to network and discharge patient/haven't admitted patient.

1. Press **Monitor Setup** key.
2. Select **Install/Service** and enter the password.
3. Select **Time Zone**
 - **Daylight Saving**: to turn on, turn off or set auto adjust daylight savings time (DST).
 - **DST Offset Hour**: to set the hours offset for daylight savings.
 - **DST Offset Minute**: to set the minutes offset for daylight savings.
 - **DST Begins**: to set daylight savings begin time.
 - **DST Ends**: to set daylight savings end time.
 - **Time Sync**: to set time sync options, **Unity** is time sync to Unity Network, **NTP** is time sync to NTP Server.
 - **NTP Config**: to set NTP Server configuration.
 - **GMT Offset Hours**: to set offset hours from GMT (Greenwich Mean Time).
 - **GMT Offset Minutes**: to set offset minutes from GMT.
 - **Primary Server IP**: to set primary NTP Server IP address.
 - **Secondary Serv IP**: to set secondary NTP Server IP address.

NOTES:

- **DST Offset Hour** and **DST Offset Minute** menu are enable only when the **Daylight Saving** is set to **ON** or **AUTO**.
- **DST Begins** and **DST Ends** menu are enable only when the **Daylight Saving** is set to **AUTO**.
- **Time Sync** menu is shown only when monitor configuration is Unity+HL7.
- **NTP Config** menu is shown only when monitor configuration is Unity+HL7 or HL7. **NTP Config** menu is enable only when **Time Sync** is set to **NTP**.

Alarms

Safety precautions

Warnings

- Verify alarm processing is active and no arrhythmia occurred during power interruption.
 - Latched alarms are not retained through monitor reset if alarm condition is been removed.
 - Do not rely on secondary alarm system for receipt of alarm signal.
 - Observe patient frequently while alarms or audio are paused or off.
 - No alarm sound during Audio Pause.
 - The audible alarm signal can be paused by central station.
 - ALARMS - Do not rely exclusively on the audible alarm system for patient monitoring. Adjustment of alarm volume to a low level or off during patient monitoring may result in a hazard to the patient. Remember that the most reliable method of patient monitoring combines close personal surveillance with correct operation of monitoring equipment. After connecting the monitor to the central station and/or nurse-call system, verify the function of the alarm system. The functions of the alarm system for monitoring of the patient must be verified at regular intervals.
 - Make sure alarms are active and set according to patient condition.
 - Only the latest and highest priority alarm is sent to CARESCAPE Network.
 - ACCURACY - If the accuracy of any value displayed on the monitor, central station, or printed on a graph strip is questionable, determine the patient's vital signs by alternative means. Verify that all equipment is working correctly.
- A potential hazard can exist if different alarm presets are used for the same or similar equipment in any single area.
 - The same or similar equipment used in any single area with different alarm presets, may present a hazard.
 - Audible alarm automatically can be sounded when monitor starting up.

Overview

The monitor provides visible and audible indications of patient or system related alarms conditions.

1. Alarm messages appear in the message field in the order of priority.
2. The alarming measurement value flashes (except for low priority alarms) and the color indicates the alarm category.
3. In some cases, a message in the digit or waveform field gives more detailed information.
4. An audible alarm is also triggered, and the alarm light indicate the alarm level.
5. High and medium priority physiological alarms; medium priority technical alarms will be stored in alarm history.

NOTE: If the monitor is connected to the network, it also sends alarms to the central station.

NOTE: If the monitor is connected to the nurse call system, the high and medium priority alarms will trigger the nurse call system.

NOTE: If the alarms are off on the monitor, the alarm limits to central station are automatically set the value, which exceed the maximum/minimum alarm limit values of bedside monitor.

NOTE: When the monitor is starting up, a self-test will automatically be performed resulting in an alarm beep an a light flash.

Alarm categories

The alarms are classified into four categories according to the priority depends primarily on the cause and alarm duration. The priority increasing with the duration and according to the physiological significance.

NOTE: Asystole, ventricular fibrillation and V Tach alarms are always high priority alarms.

Signal	Priority level			
	High	Medium	Low	Informational
Alarms in Message Field	Solid red background	Yellow boundary, blue-gray background	Cyan boundary, blue-gray background	Blue-gray background field
Alarm reset in Message Field	Solid red background with audio pause symbol	Yellow boundary, blue-gray background, with audio pause symbol	Cyan boundary, blue-gray background, with audio pause symbol	No
Physiological data values in Digit Field	Flashing red, physiological alarms only	Flashing yellow, physiological alarms only	No	No
Alarm light	Flashing red	Flashing yellow	Solid Cyan	No
Alarm tone ISO pattern	10 beeps every 5 seconds	3 beeps every 19 seconds	1 beep every 30 seconds	No
Alarm tone ISO2 pattern	10 beeps every 5 seconds (rising tone)	3 beeps every 19.5 seconds (rising tone)	1 beep every 30 seconds	No
Alarm tone IEC pattern	10 beeps every 5 seconds (rising tone)	3 beeps every 19 seconds (rising tone)	1 beep every 30 seconds	No
Alarm tone General pattern	Continuous beep	Double beep every 5 seconds	1 beep every 30 seconds	No

For more information about audible tone pattern see the "Default Configuration Worksheet".

Alarm conditions

- Physiological alarm conditions are triggered by a patient measurement exceeding the parameter limits, or by an arrhythmia condition.
- Technical alarm conditions are triggered by an electrical, mechanical, or other failure of the equipment, or by failure of a sensor or component. Technical alarm conditions may also be caused when an algorithm cannot classify or interpret the available data. The visual manifestation of a technical alarm is active as long as the reason for that alarm exists.

For more information about alarm conditions and alarm delay, see the “Default Configuration Worksheet” .

Alarm priority levels

Alarm priority levels are determined automatically, for more information about each alarm’s priority level, see the “Default Configuration Worksheet”.

Two or more alarms of equal priority are ranked according to the generated time. The latest alarm displays on the left.

Alarm priority escalation

An escalating alarm starts at a designated priority level (low or medium) and will escalate to the next higher priority level of alarm (after a set number of seconds) if the alarm condition has not been resolved. It is important to note that these escalate up to the next level but will not reset until the condition has been resolved.

NOTE: Alarm priority escalation affects the currently ongoing alarm condition, not any future alarms of the same type. Any new alarms will alarm at their designated priority level, not at the escalated level.

For more information about alarm priority escalation, see the “Default Configuration Worksheet”.

Alarm tones

The monitor has four options for alarm tones and patterns: ISO, ISO2, General and IEC. To choose the alarm tones, see [“Changing alarm options”](#).

Alarm activation

Physiological alarms have individual activation criteria as shown in the table. Alarm annunciation does not depend on case activity.

Parameter	Physiological alarm activation criteria
ECG	Active measurement for 30 seconds.
Impedance respiration	Active measurement for 30 seconds.
Apnea	After 3 breath within 1 minutes.
SpO2	After successful pulse search.
NIBP	Manual, Auto or Stat mode started.
IBP	Active measurement for 30 seconds.
Temperature	As soon as measurement readings are available.
Gases	After 1st breath detection.
Entropy	Measurement readings within the preset alarm limits for 30 seconds.

Checking alarm function

1. Set a parameter alarm limit outside of the current measured patient values. For example, connect the SpO₂ sensor and adjust the SpO₂ high limit under the measured SpO₂ values.
2. Confirm that the following alarm notification events occur:
 - The audible alarm sounds the correct tone.
 - The alarm light illuminates.
 - The SpO₂ numeric value flashes in the digit field with the correct color.
 - An alarm printout (if enabled).
3. Audio pause the alarms and confirm that the alarms are paused and that the left side of the alarm indicator light is a correct color.
4. Return the parameter alarm limit to the original value.

Adjusting limits

1. Press the **Alarms Setup** key and select **Adjust Limits**.
2. Turn the Trim knob to select the specific alarm to be configured.
3. Choose the highlight measurement.
4. Push the Trim knob to open an adjustment window.
5. Turn the Trim knob to change limits and accept them by pushing it. Move between selections by turning the Trim knob.

NOTE: If the monitor is connected to the network, the alarm limits can also be changed using the Central if this feature has been enabled in the Central configuration.

NOTE: The alarm settings will be lost after 15 minutes power off.

NOTE: When the "memory error" message is displayed, the monitor will automatically return to default settings, including the alarm preset.

Setting alarm limits automatically

When selected, the **Auto Limits** feature automatically sets new high limit and low limit values, for all monitored parameters, based upon the current physiological value.

1. Select **Alarms Setup** from the monitor's main menu.
2. Select **Auto Limits**.

Limits are calculated from the displayed patient reading at the point of time when auto limits are selected.

Returning alarm limits to their default settings

1. Select **Alarms Setup** from the monitor's main menu.
2. Select **Default Limits**.

The factory default alarm limits are listed in the "Default Configuration Worksheet"

Removing menu to view alarm limits and 10 minute trends

To clear the selection menu:

1. Press the **Alarms Setup** key.
2. Select **Remove Menu**.

Alarm limits and 10 minute trends are displayed.

NOTE: This screen is only for viewing, can not adjust alarm limits.

To return to the selection menu:

1. Press Trim Knob.

Adjusting volume

1. Press the **Alarms Setup** key.
2. Select **Alarm Volume** and adjust.

The default minimum alarm volume is 5. You can adjust minimum alarm volume through password, see "[Changing alarm options.](#)"

WARNING: Always make sure that the audio alarm volume level is adequate in your care environment.

Audible alarms off behavior

When audible alarms are turned off:



- All audible alarms are turned off except for specific alarms configured to break through the audio off setting.
- The audio off bell icon displays in the upper left corner of the display screen.
- The visual alarm signals still display.

Turning audible alarms on/off

1. Press the **Alarms Setup** key and select **Audio ON/OFF**. If this option is not selectable, see [“Changing alarm options.”](#)
2. Select an alarm group. Choices are:
 - **Silence Apnea**: Turns off audible alarms for apnea, respiration rate, EtCO₂ and FiCO₂ limit alarms, except the related technical alarms.
 - **Silence ECG**: Turns off audible alarms for all HR source (ECG, Art and Pleth) limit and arrhythmia alarms, except the related technical alarms.
 - **Silence Apn&ECG**: Turns off audible alarms for apnea, respiration rate, EtCO₂, FiCO₂, all HR source limit and arrhythmia alarms, except the related technical alarms.
 - **Silence ALL**: Turns off all audible alarms (both of physiological and technical), except specifically defined as breakthrough alarms.
3. To turn on all audible alarms again, select **Activate Alarms**

NOTE: If alarms are turned off for any of the defined alarm groups and an alarm occurs within the alarm group, a beep tone will sound every 2 minutes as a reminder that alarms are turned off.

Pause audio and alarm reset behaviors

Action	Result	Indicator
Press audio pause key once 	<ul style="list-style-type: none"> Start a 2 minute audio pause period for all alarms except the critical breakthrough alarms (for example, V Tach). See the “Default configuration worksheet” for details about breakthrough alarm Cease all latched alarms (including message and light). 	<ul style="list-style-type: none"> Alarm light: Yes Alarm message: Yes and has the audio pause countdown icon Alarm audio: No, except breakthrough alarms
Press audio pause key second time during audio paused period 	<ul style="list-style-type: none"> Cease the audio pause state. Remove alarms listed below*. 	<ul style="list-style-type: none"> Alarm light: Yes Alarm message: Yes Alarm audio: Yes
Press alarm reset key	<ul style="list-style-type: none"> Pause all active audio alarms for 2 minutes. Does not silence any new alarms. Cease all latched alarms (including message and light). Cease the audio pause state. 	<ul style="list-style-type: none"> Alarm light: Yes Alarm message: Yes, with audio pause symbol in the message block Alarm audio: No

* Alarms are listed as follow:

– Physiology alarms:

- NIBP Dia high
- NIBP Sys high
- NIBP Mean high
- NIBP Dia low
- NIBP Sys low
- NIBP Mean low

– Technical alarms:

- Leads off

- Entropy cable off
- Entropy sensor off
- Entropy sensor check failed
- No Entropy sensor
- No SpO2 probe
- SpO2 probe off
- Check SpO2 probe
- No SpO2 pulse
- No Px transducer
- NIBP cuff loose

- NIBP cuff occlusion
- Check NIBP
- Weak pulsation
- Long measurement time
- NIBP manual
- NIBP cuff overpressure
- NIBP call service error
- Gas measurements removed
- Recorder module removed
- Entropy measurement removed
- Alarm volume changed
- Zero ICP separately
- Recorder system error
- Recorder cover open
- Recorder input voltage high
- Recorder input voltage low
- Recorder out of paper
- Recorder thermal array overheat
- No battery backup

Showing alarm history

1. Press the **Pt.Data & Trends** key.
2. Select **Alarm History**: a list of the last 20 alarms are displayed for 24 hours.

Latched Alarms

When alarms are latched, the alarm messages stay on the screen even if the initial alarm condition goes away. You will also hear a reminder beep every 10 seconds.

To clear the message field of the no longer active alarm messages and to clear the beep:

- Press the **Audio Pause** key once, or
- Press **Alarm Reset** key once.

See ["Changing alarm options"](#) in ["Setting up the monitor before use"](#) chapter for how to latch alarms.

Breakthrough Alarms

The breakthrough alarms feature allows some alarms to “break through” (interrupt) an All Alarms Audio Off or a 2 minute alarm audio pause condition.

See ["Changing alarm options"](#) in ["Setting up the monitor before use"](#) chapter for how to turn on/off breakthrough alarms feature.

See the “Default configuration worksheet” delivered with the monitor for details of which alarms and conditions are enable for breakthrough feature.

Starting and ending

Safety precautions

Warnings

- Connect only one patient to the monitor at a time.
- Always make sure that appropriate mode is chosen and necessary alarm limits are active according to the patient's clinical condition.

Preparations

NOTE: Before using the monitor or the first time with batteries, charge the batteries to their full capacity (charging time 2 hours per battery pack).

1. Plug in the measurement modules.
2. Turn on the monitor from the **ON/OFF** key. The monitor performs a self-test to ensure correct functioning.

NOTE: Press the **ON/OFF** key for more than 1 second, the monitor will turn on after the red, yellow and cyan alarm lights lit in sequence, the speaker gives an audible beep and the GE logo screen display, followed by the notes screen.

Starting monitoring

1. Prepare the patient connections according to the setup picture in the measurement section. Use only approved supplies and accessories, see the "Supplies and Accessories" catalog. The alarms and parameter settings become active.
2. Enter or load patient data by pressing the **Admit/Discharge** key, according to the instructions given later in this chapter.
3. Start the measurement according to the instructions in the measurement section.
4. Zero invasive pressure lines; see "[Invasive blood pressure](#)."
5. If necessary, adjust the waveform and digit fields; see "[Modifying the screen setup](#)" in "[Setting up the monitor before use](#)" chapter for how to set.
6. Check the alarm limits; press the **Alarms Setup** key. Change them, if necessary; see "[Alarms](#)."

The patient admission happens through **Admit Patient** selection or automatically when the monitor receives a patient's vital signs.

Always observe the monitor and the patient carefully during start-up periods and when inserting module.

Entering patient data

When you admit a patient, you must enter all relevant data:

1. Press the **Admit/Discharge** and select **Admit Patient**.
2. Choose the **Patient Type** (The option **A/P** means Adult/Pediatric, the option **NEO** means Neonatal).
3. Enter patient name, ID by selecting the letters or numbers, pushing to confirm and turning the Trim knob to the following character selection.
4. Select **Demographics**, enter **Height, Weight** and **Age**. The **BSA** is automatically calculated.
5. If necessary, change the user mode: Press the **Admit/Discharge** key and select **Select Mode**.

Modes are preconfigured but if desired, they can be changed.

Changing the modes is described briefly in "[Modifying the screen setup](#)."

NOTE: Changing the mode also changes settings, such as the alarm limits. For the details of factory default settings, see the "Default Configuration Worksheet".

The monitor automatically reconfigures the display when module are inserted. Reconfiguration of the display may take up to five seconds.

Loading patient data

If the patient has already been admitted on the same monitor, press **Admit/Discharge** and select:

- **Contin. Previous**

Select this to load the most recent patient trends from the monitor memory when less than 15 minutes has elapsed from the turn-off.

NOTE: This selection is available if the patient case is already admitted on this monitor.

NOTE: When powering off the monitor, alarm history, patient data and monitor settings will be retained for 15 minutes. After 15 minutes all the information will be lost.

Saving data

The monitor continuously saves patient data, such as trends. Saving is activated once the patient is admitted. The monitor saves automatically:

- In the monitor memory the most recent patient data up to 72 hours.
- In the network the most recent patient data up to 2 to 90 days in central station depending on the configuration.

Ending monitoring

1. Print necessary data: press the **Print/Record** key.
2. Wait until the printing is finished. Then clear the patient data and return the settings, including alarm limits, to their defaults through **Admit/Discharge - Discharge - YES**
3. Turn off the monitor from the **ON/OFF** key if the monitor will not be used.
NOTE: A message "Monitor is shutting down..." will be on the screen.
4. Clean the monitor according to the instructions.

NOTE: When discharge patient, don't do any action until the "Patient discharged" message appeared.

Demo Mode

The Demo Mode is designed for training and demo of operation before use. Under Demo Mode, the monitor displays the main vital signs values and waveforms. No need accessories, central station or any other peripheral equipment connect to the monitor while in Demo Mode.

NOTE: All the values and waveforms the Monitor displays are fictional.

NOTE: The Demo Mode is only designed for the use of training and demo of operation. It is not intended for clinical use or patient monitoring and diagnosis.

The Demo Mode menu is under service menu of the monitor, it's need password to enter. Please consult the qualified service personnel to open and close the Demo Mode.

Troubleshooting

- The measured values are not displayed:
 - Check that you have selected the desired parameter to a waveform or digit field, see [“Modifying the screen setup.”](#)
- You cannot perform a measurement or a function.
 - Check that the measurement module is properly installed.
 - Remove the module and reinstall it.

Trends and Snapshot

Cautions

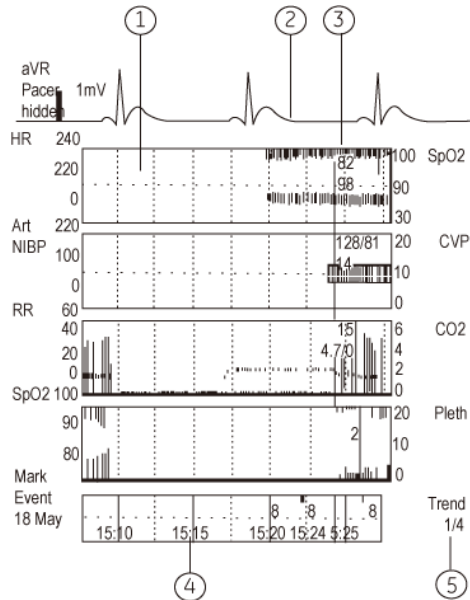

- Snapshot waveforms are in some cases drawn from compressed data that may not allow perfect reconstruction. Verify diagnostic waveform measurements with the waveform data from realtime graph strips.



Trends view

- Measurement trend field
- Real time ECG
- Numerical value of a measurement at the trend cursor point
- Time and marker field
- Trend page number

Symbols

-  **Trend bar:** the gap shows the blood pressure mean value
-  **NIBP trend bar**
-  **Indicator of change** -for example, ST relearning or zeroing of an invasive blood pressure channel/ changing a label

Viewing and printing graphical trends

To view graphical trends

1. Press the **Pt.Data & Trends** key.
2. Select **Trends - Graphical**.
 - To see more parameters, select **Scroll Pages** and scroll with the Trim Knob.
 - To see more data, select **Cursor** and scroll the page left and right with the Trim Knob.

Graphical trends contain four trend pages each having up to six preconfigured fields with different parameters. Five fields can be displayed, and six fields can be printed. Real-time ECG waveform is always displayed at the top of each page.

To adjust scales

1. Press the **Pt.Data & Trends** key.
2. Select **Trends - Graphical**.
3. Select **Time Scale** to choose graphical trend time scale.
4. Select **Trend Scales** to choose the scale for HR, ST, PVC, CPP, SpO₂ and temperature measurements.

The graphical trend time scale varies from 20 minutes to 72 hours. With the 20 minute trend length, the displayed time period is 30 minutes and the resolution 10 seconds. With trend lengths from one to 72 hours, the displayed time period is 72 hours and the resolution is one minute.

To print graphical trends

1. Press the **Pt.Data & Trends** key.
2. Select **Trends - Graphical**.
3. Select **Print Page**.

NOTE: Network laser printer only.

Viewing and printing numerical trends

Numerical trends contain four pages with the maximum of 72 hours of trend data. Real-time ECG waveform is displayed at the top of each page.

For numerical trends, can't adjust scales manually.

To view numerical trends

1. Press the **Pt.Data & Trends** key.
2. Select **Trends - Numerical**.
 - To see more pages, select **Scroll Pages** and scroll with the Trim Knob.
 - To see more data, select **Cursor** and scroll the page up and down with the Trim Knob.

To print numerical trends

1. Press the **Pt.Data & Trends** key.
2. Select **Trends - Numerical**.
3. Select **Print Page**.

NOTE: Network laser printer only.

Take snapshots

A snapshot is a frozen frame of preconfigured waveforms or trends saved in the monitor memory. You can take up to 10 snapshots. It is automatically numbered. When graphical trend view, snapshots mark "s" in mark field; when numerical trends view, the number appears in the column 'Mark'.

For configuration, see ["Configuring snapshots"](#) in section ["Setting up the monitor before use"](#).

To create a snapshot manually:

- Press the **Take Snapshot** key.

To create automatic snapshots:

The monitor can automatically take snapshots on Brady, Tachy, Art sys/dia/mean high, Art sys/dia/mean low, Asystole, V Fib and V Tach alarms if automatic snapshot creation is enabled. To enable this function, see ["Configuring snapshots"](#) in section ["Setting up the monitor before use"](#).

Viewing and printing snapshots

To view snapshots:

1. Press the **Pt.Data & Trends** key.
2. Select **Trends - Snapshot - Next Snapshot**.

Turn the Trim knob to move to the next snapshot. In the waveform field, you can see the time the snapshot was created. Five fields can be displayed on the snapshot page, and six fields can be printed.

In the trend field, the graphical trend view or the numerical trends view are displayed according to the snapshot's configuration.

To print snapshots:

1. Press the **Pt.Data & Trends** key.
2. Select **Trends - Snapshot**.
3. Select **Print Page**.

NOTE: Network laser printer only.

NOTE: If the graphical trend time scale is 20 minutes, the displayed time period is 30 minutes. So after 30 minutes of snapshot creating, the trends for that time will disappeared.

Erasing trends and snapshots

1. Press the **Admit/Discharge** key.
2. Select **Discharge**.

If the monitor has been turned off from the ON/OFF key but the patient has not been discharged, the trend data will be stored in the memory for 15 minutes.

OCRG

The monitor supports 8 minutes OCRG (oxycardiorespirogram) function in the NEONATAL mode. The OCRG subsystem provides services to view and review specific high resolution trends, high resolution beat-to-beat HR, high resolution beat-to-beat SpO₂ and compressed respiration waveform - simultaneously in the same view. Two types of views are provided: OCRG Snapshot view and OCRG Realtime view.

View OCRG snapshot

The OCRG snapshot is created when an OCRG event is triggered. Refer to "[Setup OCRG](#)" for OCRG event setup. The monitor can store up to 70 OCRG snapshots. OCRG snapshot includes the trend data 6 minutes before and 2 minutes after the OCRG event. If multiple OCRG events are triggered within 2 minutes, they will be detected as one OCRG event. During this time, only the first OCRG event will trigger OCRG Snapshot creation.

To display the OCRG snapshot record.

1. In NEONATAL mode, press the **Pt.Data & Trends** key.
2. Select **OCRG Snapshots**.

You can select **Scroll Snapshots** and scroll left and right with the Trim Knob to see the earlier OCRG snapshots. The trigger time and condition also showed on the left menu area.

You can select **Remove Menu** to hide the left side menu. Press the Trim Knob to show the menu.

View realtime OCRG

To display the realtime OCRG.

1. In NEONATAL mode, Press the **Pt.Data & Trends** key.
2. Select **OCRG Realtime**.

You can select **Remove Menu** to hide the left side menu. Press the **Trim Knob** to show the menu.

Setup OCRG

The OCRG event is that any one of HR, SpO₂, Apnea is out of OCRG triggering limits range. You can setup these limits.

Adjust OCRG alarm limits

1. In NEONATAL mode, Press the **Pt.Data & Trends** key.
2. Select **OCRG Setup**.
3. Select **Adjust Limits**.

Adjust short apnea time

1. In NEONATAL mode, Press the **Pt.Data & Trends** key.
2. Select **OCRG Setup**.
3. Select **Short Apnea**.

NOTE: The default short apnea time is 20 seconds.

Printing and recording

You need

- Laser printer for printouts (PCL5 compatible, min. 2Mb memory)
NOTE: Network printer only.
- Optional recorder configuration for recording
- Thermal paper for the recorder

NOTE: Before you start printing, check that the printer is operational.

NOTE: Recordings on thermal paper may be destroyed when exposed to light, heat, alcohol, etc. Take a photocopy for your archives.

Direct function key

Recorder Start/Stop	Start or stop recording waveforms to local recorder.
----------------------------	--

Printing with a laser printer

You can print to the network connected laser printer from central station. If the monitor connect to S/5 network, you also can print with a laser printer from monitor directly, see following instruction.

Selecting a printer

1. Press the **Print/Record** key.
2. Select **Printer Connection**.
3. Select the printer from the list.

Printing graphical trends

To print graphical trends:

1. Press the **Print/Record** key.
2. Select **Print Graphical**.
3. Setup the printing settings:
 - **Page X**: which page of the trends to be printed.
 - **Hours / Page**: how many hours trends in one page, this is used to setting up the resolution for printing.
 - **End Time**: The end time for trends to be printed. The maximum end time shall be current time.
 - **Trend Length**: how many hours to be printed. It start from end time to calculate back.
 - **Printer Connection**: which printer to print to.
4. Select **Print Graphs** to printing. You can select **Cancel Printing** to end current printing.

Printing currently displayed screen contents

You can print currently displayed trend data.

To print trend data:

- Press the **Pt.Data & Trends** key and select:
 - **Trends - Print Page**

Recording with the recorder

Recording waveforms

You can record three waveforms to a local recorder, and two to four waveforms to a network recorder:

1. Press the **Print/Record** key, select **Record Waveforms**.
2. Setup the record settings:
 - **Waveform X**: which waveform to be recorded.
 - **Start on Alarms**: whether triggered by following alarms reach the red level:
Asystole, Tachy, Brady, Art Sys/Dia/Mean high, Art Sys/Dia/Mean low, V Fib, V Tach.
 - **Delay**: record from 12 seconds prior the events, or record from current time.
 - **Paper Speed**: set up the paper speed to adjust the recorded waveforms more clearly or more generally.
 - **Length**: set up the length of the recording.
3. To start the recording, press the **Recorder Start/Stop** key, or Select **Record Waveforms - Record to Local**.
If the monitor is connected to the network, you can also use the network recorder by selecting **Record to Net**. The network recorder uses the settings of the Central.
4. To stop recording, press the **Recorder Start/Stop** key, or Select **Stop Waveforms**.

Recording numerical trends

You can record the current trends values of measured parameters.

1. Press the **Print/Record** key, select **Record Trends**.
2. Select **Num Trend Type** and **Num.** or **Tab.** to set up the format for the recorded numerical trends
3. To start the recording, select **Record Numerical**.
4. To stop recording, select **Stop Numerical**.

Recording graphical trends

1. Press the **Print/Record** key, select **Record Trends**
2. Select **Graphic. Trend 1** or **Graphic. Trend 2** to set up parameters of graphical trends.
3. To start the recording, select **Record Graphical**
4. To stop recording, select **Stop Graphical**.

Trends are recorded for the time period that corresponds to the time scale of the graphical trends.

To choose the time scale:

1. Press the **Pt.Data & Trends** key.
2. Select **Trends- Time Scale - 20 '1 h/2 h/4 h/6 h/8 h/10 h/12 h/24 h/36 h/48 h/72 h**.

Troubleshooting

- Printing is not possible:
 - Check the printer setting through **Print/Record - Printer Connection**.
 - Check that the printer is connected to the network.
 - Check the network cable.
- Recording is not possible:
 - Check the Central recorder if you are recording through network.

Cleaning and care

Safety precautions

Warnings

- Disconnect equipment from power line before cleaning
 - If liquid has accidentally entered the system or its parts, disconnect the power cord from the power supply and have the equipment serviced by authorized service personnel.
 - Regular preventive maintenance should be carried out annually.
 - Do not use unspecified cleaners, materials or chemicals as they may damage device surfaces, labels, or cause equipment failures.
 - Do not pour or spray any liquid directly on cables or leadwires or permit fluid to seep into connections or openings.
 - Never use conductive solutions, solutions that contain wax, or wax compounds to clean devices, cables or leadwires.
 - Do not immerse any part of the device in liquids or allow liquid to enter the interior.
 - The decision to sterilize must be made per your institution's requirements with an awareness of the effect on the integrity of the cable or leadwire.
 - Clean the surface of the probe before and after each patient use.
 - CABLE/SENSOR AFTER CARE
 - Do not immerse sensors or patient cables in water, solvents or cleaning solutions.
 - Do not reuse sensors intended for single patient use.
 - Do not sterilize sensors or patient cables by irradiation, steam, or ethylene oxide.
 - Clean the surface of the probe before and after each patient use.
- Allow sensor and cable to dry completely after cleaning. Moisture and dirt on the connector can affect the measurement accuracy.
 - If a probe is damaged in any way, discontinue use immediately.
 - Inaccurate SpO₂ data can result if a sensor is past its useful life.
 - A damaged sensor or a sensor soaked in liquid may cause burns during electrosurgery.
 - Since calibration gas contains anesthetic agents, always ensure sufficient ventilation of the room during calibration.
 - Inaccurate readings due to:
 - use of unapproved accessories
 - reuse of single-use accessories
 - affect on pressure strong scavenging suction
 - The user may only perform maintenance procedures specifically described in this manual.
 - On the gas module indicates that airway gases should be calibrated every six months in normal use and every two months in continuous use.
 - Do not autoclave any part of the system with steam or sterilize with ethylene oxide.

Cautions

- PACKAGING DISPOSAL - Dispose of packaging material, observing applicable waste control regulations.
- Do not use or store equipment outside the specified temperature, humidity, or altitude ranges.
- DISPOSAL - At the end of its service life, the product described in this manual, as well as its accessories, must be disposed of in compliance with the guidelines regulating the disposal of each product. If you have any questions concerning disposal of a product, please contact GE or its representatives.

Cleaning schedules

NOTE: For details about the cleaning, disinfecting, and sterilizing the accessories, see the instructions for use accompanying the accessory.

Daily and between patient

- Wipe the monitor and module surfaces with permitted cleaning agents.
- Wipe the ECG trunk cable, NIBP cuff and cables, and SpO₂ sensors with permitted cleaning agents. Avoid excessive use of liquids.
- Change or sterilize all airway and other invasive patient accessories.
- Clean, disinfect, or sterilize reusable temperature probes.
- Empty the water trap.
- Use a new Entropy sensor for each patient.
- Check that the accessories, cables, and monitor are clean and intact.
- Check that the monitor battery is charged.

Every two months

- Change the water trap when the '*Replace D-Fend*' message displays.
- Perform gas calibration when gas module is in continuous using, see [Starting calibration](#).

Every six months

- Condition the batteries, see [Conditioning the batteries](#).
- Perform gas calibration, see [Starting calibration](#).

Permitted cleaning agents

The exterior surface can be cleaned with the following disinfecting and sterilizing agents:

- Tap water
- Distilled water
- Ethyl alcohol 99.5%
- Ethyl alcohol 95 to 96%
- Ethyl alcohol 90% with methyl alcohol 10%
- Ethyl alcohol 80%
- Isopropyl alcohol 60%
- Phenol 2%
- Purified benzine
- Chloramine 5%
- Glutaraldehyde 2%

NOTE: The monitor does not directly expose the user or patient to natural latex rubber and/or PVC (polyvinyl chloride).

General cleaning instructions

To clean the monitor, module, displays, and other parts, complete the following procedure:

1. Turn off the monitor.
2. Disconnect the power cord.
3. Remove all cables and batteries (if applicable) and close battery door(s).
4. Use a soft, lint-free cloth with one of permitted cleaning agents to wipe the exterior surface.
5. Wipe off the cleaning solutions with a clean, lightly moistened cloth.
6. Dry thoroughly with a dry, lint-free cloth and let air dry for at least 30 minutes.
7. Reconnect the power cord.
8. Turn on the monitor.

NOTE: Check ventilation holes and clean if necessary.

NOTE: Any contact of cleaning agents with metal parts may cause corrosion.

NOTE: Make sure not to leave any liquid spills on any metal part.

NOTE: Do not damage or bend connector pins when cleaning or drying.

NOTE: For information regarding materials used in accessories, see the instructions for use accompanying the accessory.

Cable and leadwire cleaning instructions

To clean ECG trunk cables, NIBP cuff and cables, and other reusable sensors, complete the following procedure:

1. Remove cables and leadwires from the device before cleaning.
2. Do not pull the long wires from the connector ends. Metal connections can be pulled away from the connectors.
3. For general cleaning of cables and leadwires, wipe with a cloth moistened with a mild soap and water solution.
4. For disinfecting the cables and leadwires, wipe with a cloth lightly moistened with a diluted sodium hypochloride solution.
5. Wipe off cleaning solutions with a clean, lightly moistened cloth.
6. Dry thoroughly with a dry, lint-free cloth and let air dry for at least 30 minutes. Do not apply heat.

NOTE: Do not immerse either end of a cable or leadwire connector. Immersing or soaking the connector ends may corrode metal contact ends and effect signal quality.

For other applied parts e.g. temperature sensors, catheters, pulse oximetry probes, and other reusable accessory parts, see the manufacturer instructions for cleaning, sterilization, or disinfecting methods.

Gas module water trap cleaning instructions

- Empty the water trap container when it is more than half full. With a sample gas temperature of 37°C, a room temperature of 23°C, and sample gas relative humidity of 100 %RH, the water trap should be emptied every 24 hours (applies when the sample gas flow is within 120 ± 20 ml/min for E-sCO₂, E-sCAiO and N-CAiO, 150 ± 25 ml/min for E-miniC).
- In anesthesia: Replace the water trap every two months or when the message 'Replace D-Fend' displays.
- In critical care: Replace the water trap every 24 hours, for each new patient, or when the message 'Replace D-Fend' displays.
- When replacing a water trap, mark the date on the appropriate label on the water trap cartridge.
- The water trap cartridge is disposable. Do not wash or reuse the cartridge.

WARNING - Do not disinfect or open the water trap cartridge. Do not touch the water trap membrane. The hydrophobic membrane is damaged if any cleaning is attempted other than rinsing with water.

Conditioning the batteries

Condition the batteries regularly to maintain their useful life. Condition a battery every six months or when the message 'Condition Battery A' or 'Condition Battery B' displays. The monitor displays battery status messages and symbols. You can also check the battery status through **Monitor Setup - Battery Setup**. For more information, see "[Replacing the batteries](#)", "[Symbols](#)" and "[Messages](#)."

Detailed instructions for conditioning the batteries can be found in the "User's Reference Manual."

Power interruption

NOTE: Always use the monitor with batteries inserted.

If the monitor is turned off, trend data and the temporary settings are remained for 15 minutes even if the mains power is interrupted. After 15 minutes, trend data is lost and the monitor returns to the user default settings (startup mode).

Recycling the batteries

When the battery no longer holds a charge, it should be replaced. Remove the battery and follow your local recycling guidelines.

Changing fuses

1. Remove the power cord if used.
2. Remove the fuse holder.
3. If a fuse is blown, replace it with a fuse of the correct type and rating.

Regular checks

When you start monitoring, check that:

- The module is firmly in place.
- Accessories are intact and properly connected.
- The appropriate parameters display in the digit and waveform fields.

ECG and impedance respiration

- After connecting the ECG cable, check that the message 'Leads off' displays in waveform field .

NIBP

- After connecting NIBP cable, check that the message 'Adult/ Pediatric' or 'Neonatal' displays in NIBP digital field for several seconds.

Pulse oximetry

- After connecting the SpO₂ cable and sensor, check that the red light is lit in the sensor.

Temperature

- After connecting the Temperature cable and sensor, check that the message 'Performing temp test' displays in Temperature digital field for several seconds.

IBP

- After connecting the IBP cable and transducer, check that the message 'InvBP's not zeroed' displays in message field.

Airway gas

- Check that the acquisition module is connected to the monitor.
- After installing the module, check that the message 'Calibrating gas sensor' displays in gas waveform field for about 1 minute.

Entropy

- Check that the acquisition module is connected to the monitor.
- After connecting the Entropy sensor cable to the module, check that the message "No sensor" displays.

Functioning of the alarm

- Check that the red, yellow, and cyan alarm lights are lit and the speaker sounds an audible tone when the monitor starts up.

If the monitor does not work as described, see "[Troubleshooting](#)".

Software safety checks

GE software design controls include the performance of a risk analysis using methods consistent with ISO 14971 Medical devices - Application of risk management to medical devices.

The monitor software employs watchdog timers, self-monitoring activities (e.g., memory, communication, and sensor checks), and power-on self-diagnostics (e.g., memory checksums).

Preventative maintenance

GE recommends performing preventative maintenance every year. For more information, See the "Technical Reference Manual."

Calibrating

Calibrating airway gases

Follow the recommended calibration intervals (every six months in normal use and every two months in continuous use) to ensure that the measurement accuracy remains within specifications.

Required tools

PN	Description
755534-HEL	Calibration Gas Regulator
M1006864	Calibration Gas Regulator (US only)
-	3 m/10 ft anesthesia gas sampling line
755583-HEL	Calibration gas, CO ₂ , O ₂ , N ₂ O, DESF, package of 1 can (with E-sCAiO or N-CAiO module)
755581-HEL	QUICK CAL calibration gas, CO ₂ , O ₂ , N ₂ O, package of 4 cans (with E-sCO module)
755571-HEL	Calibration Gas, 5% CO ₂ , 54.5% O ₂ , 36.0% N ₂ O, 2.0% DESFLURANE, BAL N ₂ (with E-sCAiO or N-CAiO module, US only)
755587	Calibration Gas, CO ₂ , O ₂ , Balance, 4 cans/pkg (with E-sCO module, US only)

NOTE: Use only GE approved calibration gas for the gas calibration to ensure measurement accuracy. Do not use any other calibration gases. Check the calibration gas container's labelling to ensure that the calibration gas has not expired.

NOTE: Ensure that the gas regulator is functioning properly before gas calibration. Refer to the gas regulator's "Instructions for Use" for the annual maintenance instructions.

Before calibration

1. Ensure that the module is connected to the monitor. Ensure that you have an appropriate water trap in use.
2. Turn on the monitor. Let the monitor warm up for 30 minutes.
3. Attach a regulator to the calibration gas container.
4. Connect a new gas sampling line to the sampling line connector in the water trap.
5. Connect the other end of the gas sampling line to the regulator on the gas container. Leave the regulator overflow port open to room air.

NOTE: Gas calibration is not possible if the following messages are displayed: *'Sample line blocked'*, *'Check D-Fend'* and/or *'Check sample gas out'*. Resolve the alarm condition before starting calibration.

Starting calibration

1. On the monitor, select **Airway Gas > Gas Calibration**
2. The monitor will start automatic zeroing the gas sensors. Wait until the message *'Zeroing'* is replaced by the message *'Zero OK'* for all measured gases.
3. Open the regulator after the message *'Feed gas'* displays for all measured gases. The measured gas concentrations are shown in real-time in the gas calibration menu. Continue feeding the calibration gas until the measured gas concentrations are stabilized and the message *'Adjust'* displays for all measured gases.
4. Close the regulator.
5. Use the Trim Knob to adjust the gas readings displayed to match with the gas readings in the labelling of the calibration gas container. Press the Trim Knob to accept the adjusted values when the gas readings match.
6. Wait until the message *'OK'* displays for all measured gases.

NOTE: The message '*Zero error*' displays in case the zeroing fails.

NOTE: The message '*Calibration failed*' displays, if you do not start feeding gas within one minute after the automatic zeroing is complete, or if the calibration fails due to a large gain adjustment.

NOTE: If zeroing or calibration failed, select **Recalibrate** to restart the calibration procedure.

Checking temperature, NIBP and invasive blood pressure calibration

Checking temperature, NIBP and invasive blood pressures calibration should be performed at least once a year by qualified service personnel as a part of the Planned Maintenance. for more information, see the "Technical Reference Manual."

ECG

Safety precautions

Warnings

- Make sure that the leadwire set clips or snaps do not touch any electrically conductive material including earth.
- Whenever patient defibrillation is a possibility, use non-polarizing (silver/silver chloride construction) electrodes for ECG monitoring.
- Single-use devices and accessories are not designed to be reused. Reuse may cause a risk of contamination and affect the measurement accuracy.
- Proper placement of defibrillator paddles in relation to the electrodes is required to ensure successful defibrillation.
- To ensure proper defibrillator protection, use only defibrillator proof transducers and cables.
- Set the pacemaker rate responsive mode off or turn off the impedance respiration measurement on the monitor.
- Do not use equipment for positioning (floating) temporary pacemaker leadwires, performing pericardiocentesis, or other internal applications.

- HEART RATE ALARM INTERFERENCE – Poor cable positioning or improper electrode preparation may cause line isolation monitor transients to resemble actual cardiac waveforms and thus inhibit heart rate alarms. To minimize this problem, follow proper electrode placement and cable positioning guidelines provided with this product.
- Do not use the electrodes of dissimilar metals.

Cautions

- When using the electrosurgery unit, ensure proper contact of the ESU return electrode to the patient to avoid possible burns at monitor measurement sites. Also ensure that the ESU return electrode is near the operating area.
- Patient's skin may become irritated after long contact with electrode gel or adhesive.
- The impedance respiration measurement may cause rate changes in Minute Ventilation Rate Responsive Pacemakers.

ECG equipment to patient connection

- (1) ECG connector
- (2) Multi-Link 5-lead ECG trunk cable, or 3-lead ECG cable
- (3) 3 or 5 leadwire set

NOTE: For a comprehensive list of accessories, see the "Supplies and Accessories" catalog accompanying the monitor. Check the expiration date of the ECG electrodes.

NOTE: Keep the ECG cable, lead set, and module connectors dry. Avoid excessive use of liquids when cleaning cables and connectors.

NOTE: In 5-lead ECG, place the 5th electrode (C/V) in one of the six places indicated, and select the corresponding V lead label.

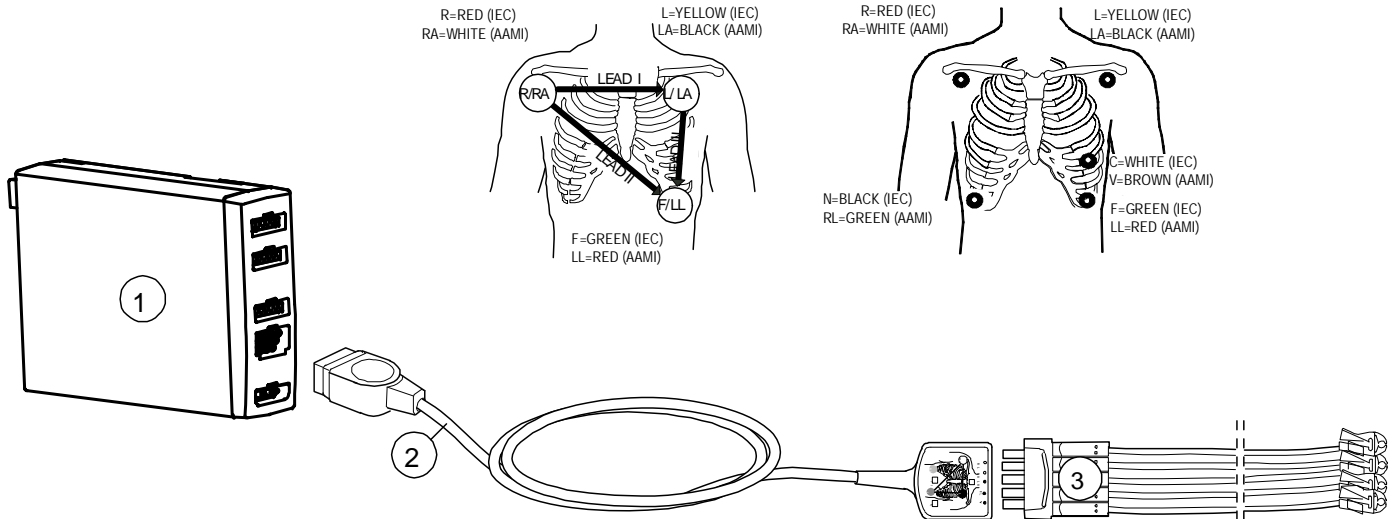

Connecting ECG leadwire sets to ECG trunk cables

- For 3-lead ECG, use the Multi-Link 3-lead ECG cable with integrated leadwires or connect a 3 leadwire set to the Multi-Link 3- or 5-lead ECG trunk cable.
- For 5-lead ECG, connect a 5 leadwire set to the Multi-Link 5-lead ECG cable.

Preparing the patient's electrodes sites

Excessive body hair or skin oil reduces electrode contact with the skin and decreases the quality of electrode signal. When preparing the electrode sites, avoid bones close to skin, obvious layers of fat and major muscles.

1. Shave any hair from the electrode sites.
2. Gently rub the skin surface to increase capillary blood flow.
3. Clean the skin with alcohol or a mild soap and water solution to remove dead skin cells and oil.
4. Dry the skin completely before applying the electrodes.

NOTE: Do not use the electrodes with dissimilar metals.

Applying the electrodes to the patient

1. Place the electrodes on the prepared sites.
2. Stabilize the electrode and leadwire with a leadwire stress loop near the electrode.
3. Tape the stress loop to the patient (excluding neonates).

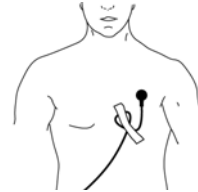

A secured stress loop prevents leadwire rotation on the electrode snap, leadwire tugging at the electrode, and ECG artifact.

ECG electrode placement

IEC	AHA	Electrode placement
R (red)	RA (white)	Just below the right clavicle.
L (yellow)	LA (black)	Just below the left clavicle.
C (white)	V (brown)	For the 5-lead placement, place the precordial electrode according to the physician's preference.
N (black)	RL (green)	Lower right edge of the rib cage.
F (green)	LL (red)	Lower left edge of the rib cage.

For a 3-leadwire electrode placement, the R/RA, L/LA, and F/LL electrodes should be used.

Selecting the ECG leads

1. Press the **ECG** key.
2. Select a lead for **ECG1 Lead**, **ECG2 Lead**, or **ECG3 Lead**.

With 3-lead ECG, only one lead (**ECG1 Lead**) can be selected. With 5-lead ECG, you can select three leads.

Selecting ECG waveforms to display

- To select the number of ECG waveforms displayed in Normal Screen, press **Monitor Setup** and select **Screen Setup - Waveform Fields**.
With 3-lead ECG, one lead can be displayed, and with 5-lead ECG, up to three leads can be displayed.
- To cascade a lead, press **ECG** and select **ECG2 Lead/ECG3 Lead - Casc.**
- To increase ECG amplitude, press **ECG** and select **ECG Size**.
- To change the waveform sweep speed, press **Monitor Setup**, select **Sweep Speeds - Hemodynamics**, and adjust the value.

NOTE: The module input circuits are protected against the effects of electrosurgery and defibrillation. However, the ECG waveform on the monitor screen may be disturbed during electrosurgery.

Selecting the number of electrodes for 5-lead ECG

1. Press the **ECG** key.
2. Select **ECG Setup**.
3. Select **5-lead Cable - 3select** or **5select**.

Selecting V Lead label

With 5-lead ECG, one V lead is measured according to the placement of the V lead electrode.

1. Press the **ECG** key.
2. Select **ECG Setup - V Lead**.

Selecting the ECG filter

1. Press the **ECG** key.
2. Select **ECG Setup - Filter**, and select the appropriate option:
 - **STfilt**: Filters high-frequency artifacts but catches slow ST changes.
 - **Monit**: Filters high-frequency artifacts and slow ST changes.
 - **Diagn**: Catches high-frequency changes and slow ST changes.

Changing the HR source

1. Press the **ECG** key.
2. Select **ECG Setup - HR Source**, and select the appropriate option.
 - **AUTO**, which selects the first available HR source
 - **ECG**
 - **Art**
 - **ABP**
 - **UAC**
 - **Pleth**

NOTE: **Art**, **ABP**, and **UAC** display when a related label is selected.

Selecting other HR parameters

You can select what is displayed with heart rate:

1. Press the **ECG** key.
2. Select **ECG Setup - Display with HR**, and select the appropriate option.
 - **PR**
 - **PVC**
 - **None**.

Displaying the ECG grid

1. Press the **ECG** key.
2. Select **ECG Setup - Grid**, and select the appropriate option:
 - **ON**: To view ECG waveforms over gridlines
 - **OFF**: To view ECG waveforms without gridlines

Adjusting the beat sound volume

1. Press the **ECG** key.
2. Select **ECG Setup - Beat Sound Volume**.
3. Adjust the volume from **0** to **10**. If you select **0**, there is no audible sound.

Setting the ECG alarms

1. Press the **ECG** key.
2. Select **ECG Alarms**.
 - To set up the limits, select **Adjust Limits**.
 - To OFF/ON the HR limits, select **HR Alarm**.
 - To OFF/ON the PVC limits, select **PVC Alarm**.
 - To adjust ST limits, select **ST Alarms**.
3. You can also select **Alarms Setup** to adjust ECG or related alarms.

For your notes:

Pacemaker detection

Warnings

- Do not diagnostically interpret pacemaker spike size and shape.
- A pacemaker pulse can be counted as a QRS during asystole in either pace mode. Keep pacemaker patients under close observation.
- The shape of QRS complex may be changed so much because of the pacemaker that QRS detection may be affected.
- The monitoring of pacemaker patients can only occur with the pace program activated.
- PACEMAKER PATIENTS - Rate meters may continue to count the pacemaker rate during occurrences of cardiac arrest or some arrhythmias. Do not rely entirely upon rate meter alarms. Keep pacemaker patients under close surveillance. See "[ECG specifications](#)" for the pacemaker pulse rejection capability of this instrument.
- FALSE CALLS — False low heart rate indicators or false Asystole calls may result with certain pacemakers because of pacemaker artifact such as electrical overshoot of the pacemaker overlapping the true QRS complexes.

Monitoring pacemaker patients

1. Press the **ECG** key.
2. Select **ECG Setup - Pacemaker**, and select the appropriate option:
 - **Show**: Pacemaker spike is displayed on the ECG waveform.
 - **Sensit**: Sensitive pacemaker detection; pacemaker spike displayed on the ECG waveform.
 - **Hide**: Pacemaker spike is not displayed on the ECG waveform.

NOTE: If the patient has an atrial pacemaker, ST calculations can be performed if the pacemaker spike does not coincide with the ISO point's adjustment range.

NOTE: Pacemaker detection may not occur during the use of high-frequency (HF) surgical equipment. The disturbance of HF surgical equipment typically causes false positive pacemaker detection.

NOTE: In Neonatal mode, pacemaker spike is never displayed on the ECG waveform.

For your notes:

Arrhythmia detection

NOTE: The VSP-C software only supports severe analysis, which detects asystole, bradycardia, tachycardia, ventricular fibrillation, and ventricular tachycardia.

Warnings

- LOSS OR DETERIORATION OF ARRHYTHMIA DETECTION – Automated arrhythmia analysis programs may incorrectly identify the presence or absence of an arrhythmia. A physician must therefore interpret the arrhythmia information in conjunction with other clinical findings. Please take special note of the following ECG waveform conditions:
 - Noisy waveforms. Noisy portions of ECG waveforms are typically excluded from analysis. The exclusions are necessary to reduce the occurrence of inaccurate beat interpretations and/or rhythm alarms. If the excluded noisy portions of the ECG waveform contain true arrhythmia events, those events may remain undetected by the system.
 - Beat amplitude and duration. Accurate detection and interpretation of beats becomes increasingly difficult as the amplitude and/or duration of those beats approach the design limits of the analysis program. Thus, as beats become extremely wide or narrow, or especially as beats become small, arrhythmia interpretation performance may degrade.
 - Other morphology considerations. Automated arrhythmia detection algorithms are designed fundamentally to detect significant changes in QRS morphology. If an arrhythmia event is present and does not exhibit a significant change from the patient's predominant morphology, it is possible for those events remain undetected by the system.

- SUSPENDED ANALYSIS - Certain conditions suspend arrhythmia analysis. When suspended, arrhythmia conditions are not detected and alarms associated with arrhythmias do not occur. The messages which alert you to the conditions causing suspended arrhythmia analysis are: 'Arrhythmia Paused', 'Leads off' and 'Patient discharged'.
- Always monitor ECG for arrhythmia detection purposes. HR calculated from pulsatile SpO₂ waveform may differ significantly from ECG HR measured values. Users should be aware that the "SpO2 probe off" and "No SpO2 pulse" technical alarms escalate no higher than a Medium priority.
- Artifact and arrhythmia paused alarm - The artifact and arrhythmia paused alarm indicates that the system is no longer monitoring ECG and there may be no Tachy or Brady alarms.

About arrhythmia detection

When an ECG signal is detected at the start of monitoring, the arrhythmia detection algorithm begins acquiring and analyzing QRS complexes in the leads used for arrhythmia detection. This phase is known as learning. Once learning is complete, the dominant QRS complex is stored as a reference template. Reference template is used as a normal morphology of that patient and it is compared with incoming beats to identify possible arrhythmias.

The EK-Pro arrhythmia detection algorithm is used. EK-Pro simultaneously analyzes leads I, II, III, and V. Once learning is complete, the dominant QRS complex becomes the template.

The algorithm uses continuous correlation, incremental template updating, and contextual analysis. Continuous correlation attempts

to find the best match between each incoming complex and the set of stored (learned) templates. If no match is found with the existing template, a new template is stored for the identified new QRS shape. Incremental template updating allows information from each beat, that correlates over time, to be reflected in the associated template. Contextual analysis uses information from neighboring QRS complexes along with existing template measurements to make the best possible decision regarding the beat's origin (e.g., early, wide).

NOTE: With a 3 leadwire trunk cable, the algorithm uses the selected one available lead **ECG1 Lead**, which is I, II or III, depending on the selected user lead.

Manually relearning the ECG pattern

When the patient's ECG pattern changes considerably, the monitor automatically relearns the new ECG pattern.

To manually relearn the ECG pattern, through **ECG - Relearn - Start**.

Selecting arrhythmia alarm for snapshots

1. Press the **ECG** key.
2. Select **ECG Alarms - Arrh. Alarms - Adjust**.
3. Select **YES** (default) or **NO** for each alarm.

Detecting arrhythmia alarms

NOTE: Arrhythmia alarms are not to be used for diagnosis. A physician must analyze the arrhythmia information in conjunction with other clinical findings.

For information about detection performance and test results of the arrhythmia algorithm testing, see "User's Reference Manual: ECG."

Alarm	Criteria
Asystole	HR is decreased to zero, the V Fib alarm is not displayed, and a beat detection has not occurred in the last two seconds.
Brady	HR below the HR alarm limit.
Tachy	HR over the HR alarm limit.
V Fib	Occurs when the ECG waveform indicates a chaotic ventricular rhythm.
V Tach	Six or more consecutive PVCs with a successive beats over 100 bpm.

ST Detection

The monitor analyzes ST for all measured leads and displays ST trends separately for each lead. ST analysis starts automatically after the leads have been connected and the QRS detection has started.

ST is displayed as digits and trends. For more information about detection performance and test results of ST segment measurement algorithm testing, see the "User's Reference Manual: ECG."

NOTE: ST segment changes may be affected by some drugs or metabolic and conduction disturbances.

NOTE: The significance of the ST segment changes needs to be determined by a physician.

Adjusting the measurement points

Automatically selecting ST measurement points

The ST algorithm automatically searches for the J and ISO points. The distance between the ST and J point is set according to the heart rate:

- If the heart rate is less than 120 bpm, the ST point is set at J + 80 ms.
- If the heart rate is more than or equal to 120 bpm, the ST point is set at J + 60 ms.

Manually adjusting ST measurement points

The J, ISO and ST measurement points can also be selected manually. If any the measurement points are manually selected, the other two measurement points are set to the current values.

1. Press the **ECG** key
2. Select **Adjust ST**.
3. Select **Set ISO point**, **Set J point** or **ST point** (where the value is the delay between J-point and ST-point in milliseconds).

Adjusting the ST alarms

1. Press the **ECG** key.
2. Select **ECG Alarms - ST Alarms**.
 - To set up the limits, select **Adjust Limits**.
 - To OFF/ON the lateral limits, select **Lat. Alarm**.
 - To OFF/ON the inferior limits, select **Inf. Alarm**.
 - To OFF/ON the anterior limits, select **Ant. Alarm**.
3. You can also select **Alarms Setup** to adjust ST or related alarms.

About the ST segment measurement algorithm

The ST segment begins at the point where the QRS ends (J point). Diagnostic criteria of ST segment changes are measured at 60 ms after the J point. For monitoring purposes it is important to keep the measurement point fixed during monitoring to notice the ST changes on the respective trends.

The sophisticated algorithms of monitor search the J and isoelectric (ISO) points. The system learns the ECG and stores the reference QRST complex. The algorithm sets the ISO and J points. Due to the large variation with QRST complexes the user has possibility to adjust the ST measurement points manually. The QRS analysis classifies each beat by using several criteria and rejects distorted complexes from the ST calculation.

NOTE: The ST algorithm has been tested for accuracy of the ST segment data. The significance of the ST segment changes needs to be determined by a physician.

Impedance respiration

Safety precautions

Warnings

- Make sure that the leadwire set clips or snaps do not touch any electrically conductive material including earth.
- The monitor may not detect all episodes of inadequate breathing, nor does it distinguish between central, obstructive and mixed apnea events.
- ELECTRODE CONFIGURATION - Impedance respiration monitoring is not reliable when ECG electrodes are placed on the limbs.
- This device is not an apnea monitor system intended to alarm primarily upon the cessation of breathing. In central apnea it indicates an alarm after a pre-determined time since the last breath detection. Do not attempt to use it for detecting obstructive or mixed apneas, since respiration movements and impedance variations may continue in these cases.
- The impedance respiration measurement is inherently very sensitive as it measures very small physiologic signals (changes of impedance of the patient's chest area). Conducted RF current above 1 Vrms may cause erroneous measurements at various frequencies, for example interference with the signal/waveform leads to respiration rate readings inconsistent with the patient's true respiration rate. If you notice this, use another form of respiration monitoring, for instance, the E-miniC module.
- Electrical interference - Electrical devices, such as electrosurgery units and infrared heaters, that emit electromagnetic disturbance may cause artifacts or disable the respiration measurement completely.
- Movement artifacts - Changing position, moving the head, moving the arms or shivering may result in movement artifacts.

Also the heart may cause noticeable movement and sometimes this may interfere with the respiration measurement.

- Intermittent mechanical ventilation - During spontaneous breathing the ventilator may at times support the patient's ventilation with an extra inspiration. If these ventilator inspirations are substantially larger than the spontaneous breaths, the respiration calculation may mistakenly count only the inspirations and expirations produced by the ventilator.
- The impedance respiration measurement may cause rate changes in Minute Ventilation Rate Responsive Pacemakers. Set the pacemaker rate responsive mode off or turn off the impedance respiration measurement on the monitor.
- APNEA alarm - If you deactivate the Apnea alarm, keep the patient under close surveillance.

Cautions

- When using the electrosurgery unit, ensure proper contact of the ESU return electrode to the patient to avoid burns at measurement sites. Also ensure that the ESU return electrode is near the operating area.

Respiration equipment to patient connection

Use the same setup as in the ECG measurement, see "ECG" section.

NOTE: Impedance respiration measurement with neonates is not available in specific regions, including USA, Argentina, Guam, Puerto Rico, Saint Croix, Saint Thomas, and Canada.

Turning on the respiration measurement

Select respiration to a waveform or digit field, otherwise respiration data is not included in trends and no alarms are activated.

1. Press the **Others** key.
2. Select **Resp Setup - Measurement - ON**.

Selecting the respiration waveform size

1. Press the **Others** key and select **Resp Setup**.
2. Select **Size**.
The greater the value, the larger the waveform size.

Selecting the respiration rate source

1. Press the **Others** key
2. Select **Resp Setup - Resp Rate Source**
3. Select the appropriate option:
 - **AUTO**
 - **CO2**
 - **Imped.**

NOTE: The **AUTO** selection lets the monitor choose the respiration rate source. If CO₂ is monitored, it is chosen to be used. If not, then impedance respiration is chosen as the respiration rate source.

Adjusting the respiration detection limit

Normally, the **AUTO** detection limit is recommended. However, if the respiration is weak or affected by artifacts, they may not be included in the respiration rate. To ensure the correct respiration rate, adjust detection limits:

1. Press the **Others** key.
2. Select **Resp Setup - Detection Limit**.
3. Adjust the limits.

Turning off the respiration measurement

1. Press the **Others** key
2. Select **Resp Setup - Measurement - OFF**.

Adjusting the no breath time

If the monitor has the NeoResp license, in the neonatal mode, the impedance respiration can set up the detect time for alarm “No Breath”.

1. Press the **Others** key
2. Select **Resp Setup - No Breath Time**
The default detection time is 15s.

Adjusting respiration alarms

1. Press the **Others** key.
2. Select **Resp Setup - Resp Rate Alarm**.
 - To set up the limits, select **Adjust Limits**.
 - To OFF/ON the limits, select **RR Alarm**.
3. You can also select **Alarms Setup** to adjust RESP or related alarms.

Troubleshooting

- Measurement fails:
 - Check the electrode quality and positioning.
 - Adjust the detection limits. During ventilator supported breathing, the respiration calculation may count only ventilator-produced inspirations and expirations.
 - Other electrical devices may interfere with the measurement.

For your notes:

Pulse oximetry (SpO₂)

Safety precautions

Warnings

- Allow sensor and cable to dry completely after cleaning. Moisture and dirt on the connector can affect the measurement accuracy.
- To prevent erroneous readings, do not use physically damaged sensors, cables or modules. Discard a damaged sensor or cable immediately. Never repair a damaged sensor or cable; never use a sensor or cable repaired by others. A damaged sensor or a sensor soaked in liquid may cause burns during electrosurgery.
- Inaccurate SpO₂ data can result if a sensor is past its useful life. Therefore, re-evaluate the measurement periodically by performing additional assessment of the patient and equipment, including consideration of use of alternate monitoring methods such as direct measurement of arterial oxyhemoglobin saturation (SaO₂).
- Conditions that may cause inaccurate readings and impact alarms include interfering substances, excessive ambient light, electrical interference, ventricular septal defects (VSD), excessive motion, low perfusion, low signal strength, incorrect sensor placement, poor sensor fit, and/or movement of the sensor on the patient.
- Physiological characteristics of the patient can affect the SpO₂ signal and readings.
- NEONATAL - The display of inaccurate pulse oximetry (SpO₂) values has been linked to the presence of poor signal strength or artifact due to patient motion during signal analysis. This condition is most likely to be encountered when the monitor is

used on neonates or infants. These same conditions in adults do not impact the SpO₂ values to the same extent.

We recommend the application of the following criteria when using the pulse oximetry function on neonates and infants:

- The peripheral pulse rate (PPR) as determined by the SpO₂ function must be within 10% of the heart rate, and
- The SpO₂ signal strength should be adequate. This is indicated by the display of two or three asterisks or the absence of a Low Signal Quality message.

Procedures or devices previously applied in your facility for SpO₂ monitoring should be used in the event the SpO₂ value from the monitor cannot be validated by the above criteria.

- If the accuracy of any measurement does not seem reasonable, first check the patient's vital signs, then check for conditions that may cause inaccurate SpO₂ readings. If the problem is still not resolved, check the SpO₂ module or sensor for proper functioning.
- Oximetry performance may be impaired when patient perfusion is low or signal attenuation is high.
- The operator is responsible for checking the compatibility of the pulse oximetry monitor, sensor, and patient cable prior to use. Incompatible components can result in degraded performance and/or device malfunction.
- SpO₂ readings may be inaccurate for a short time after defibrillation.
- Change the sensor site immediately if there is evidence of blistering, skin erosion, or ischemic skin necrosis (such as skin discoloration or reddening). Otherwise, change the site every four hours.
- A pulse oximeter should not be used as an apnea monitor.

- A pulse oximeter should be considered an early warning device. As a trend toward patient deoxygenation is indicated, blood samples should be analyzed by a laboratory CO-oximeter to completely understand the patient's condition. Check that the pulse oximetry waveform is physiological in shape to ensure waveform quality and minimize noise spikes caused by motion conditions. (Not applicable when monitoring SpO₂ with Masimo SET technology).
- Interfering substances can affect the SpO₂ reading.
- Improper sensor placement can affect the SpO₂ signal and readings.
- Do not allow tape to block the probe light detector.
- During electrosurgery the SpO₂ measurement results may be incorrect.
- Using the Maximum sensitivity setting delays the "Probe off" Patient detection alarm.
- If you deactivate the "SpO₂ probe off" alarm, keep the patient under close surveillance.

Cautions

- Prolonged monitoring or incorrect sensor application can cause skin irritation or impaired circulation. Recommend checking probe site every four hours (more frequently for poor perfusion or neonate). Refer to instructions supplied with sensor.

Measurement limitations

- The pulse oximeter cannot distinguish between oxyhemoglobin and dyshemoglobins.
- Poor perfusion may affect the accuracy of measurement when using the ear probe.
- To avoid erroneous readings, do not use a blood pressure cuff or arterial blood pressure measurement device in the same limb as the sensor.

SpO₂ Configuration

The monitor have three options for SpO₂ configuration: GE TruSignal, Masimo and Nellcor. The set up will be preconfigured by the manufacturer according to your choice. Different setup may have different performance, please refer to "[Technical specifications](#)" for more details.

Patents

The device is covered one or more below USA patents or international equivalents:

Masimo

5,758,644; 6,011,986; 6,699,194; 7,215,986; 7,254,433; 7,530,955 and other applicable patents listed at: <http://www.masimo.com/patents.htm>.

Nellcor

5,485,847; 5,676,141; 5,743,263; 6,035,223; 6,226,539; 6,411,833; 6,463,310; 6,591,123; 6,708,049; 7,016,715; 7,039,538; 7,120,479; 7,120,480; 7,142,142; 7,162,288; 7,190,985; 7,194,293; 7,209,774; 7,212,847; 7,400,919.

SpO₂ to patient connection

- (1) Compatible SpO₂ measurement capability
- (2) Interconnect cable
- (3) Reusable sensors
- (4) Disposable sensors

NOTE: For a comprehensive list of accessories, see the "Supplies and Accessories" catalog delivered with the monitor.

NOTE: For each SpO₂ accessory, refer to the instructions for use in the accessory package for patient weight limits.

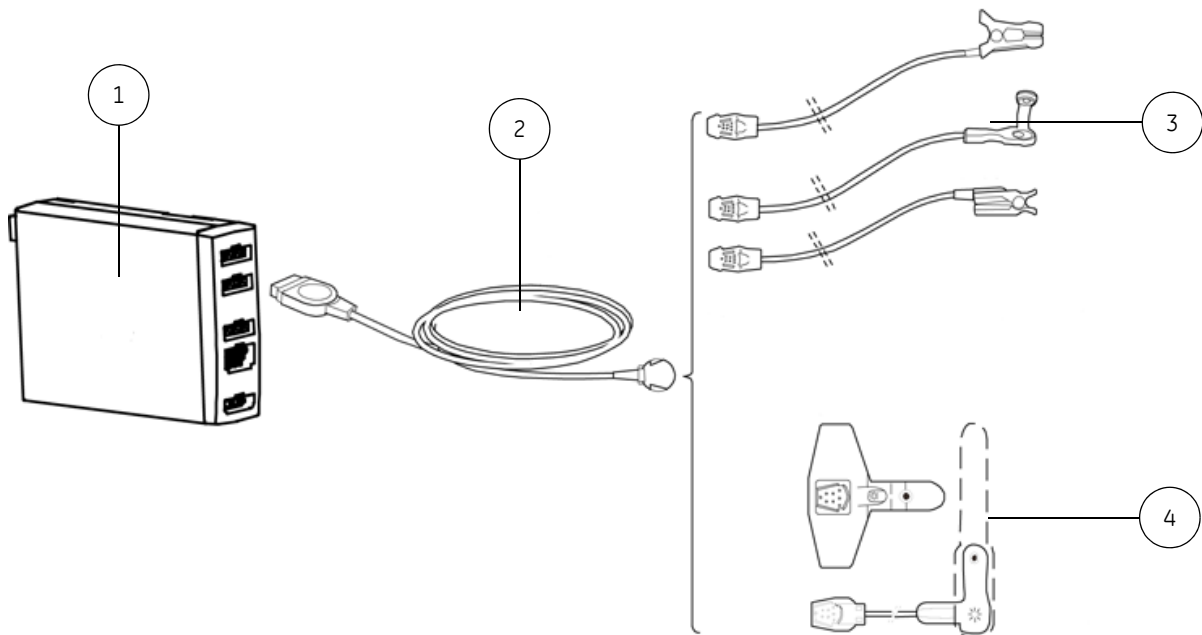

Preparing the patient for a SpO₂ measurement

1. Connect the sensor to the blue connector in the monitor.
2. Clean the surface of reusable sensors.
3. Clean the application site. Remove nail polish, artificial fingernails, earrings etc.
4. Clip long fingernails.
5. Attach the sensor cable to the wrist or bedclothes to prevent the cable and sensor from moving.
6. Check that the red light is in the sensor.
7. Check that the waveforms and parameter values are displayed when the probe is connected to the patient.

NOTE: Use dry and clean sensors only.

NOTE: Do not use a blood pressure cuff or arterial blood pressure measurement device on the same limb as the sensor.

NOTE: GE Healthcare sensors are latex-free. Refer to the introduction of each type of probes, to make sure the materials with which patient or any other person may come into contact.

Selecting the SpO₂ heart rate

The heart rate can originate from various sources. Displaying the pulse rate measured with pulse oximetry:

1. Press the **SpO₂** key.
2. Select **HR Source - Pleth**.

NOTE: **Art, ABP, UAC** is visible when a related label is selected.

NOTE: The **AUTO** selection priorities for heart rate calculation are: ECG (the lead with highest R-wave), pressure (Art, ABP, UAC) and plethysmographic pulse waveform.

Adjusting SpO₂ pulse beep tone volume

You can adjust the volume of the beat sound:

1. Press the **SpO₂** key.
2. Select **Beat Sound Volume**.

Adjusting the SpO₂ waveform scale

1. Press the **SpO₂** key.
2. Select **Pleth Scale**.

NOTE: When the configuration is GE TruSignal SpO₂, it will have **AUTO** selection for scale, which is automatically selected according to the IrMod% (infrared modulation percentage) that is received from the measurement source.

Adjusting the GE TruSignal SpO₂ response averaging time

1. Press the **SpO₂** key.
2. Select **SpO₂ Response**.

Adjusting the Masimo SpO₂ averaging time

NOTE: For SpO₂ modules with Masimo technology and Masimo sensors.

1. Press the **SpO₂** key.
2. Select **Averaging**.

Adjusting the Masimo SpO₂ sensor sensitivity level

NOTE: For SpO₂ modules with Masimo technology and Masimo sensors.

1. Press the **SpO₂** key.
2. Select **Sensitivity**.
 - Use the **Normal** sensitivity setting for normal patient monitoring purposes.
 - Use the **Maximum** sensitivity setting for improved poor perfusion performance and for faster tracking of rapid SpO₂ saturation changes.

Stopping the SpO₂ measurement

1. Remove the SpO₂ sensor from the patient.
2. Disconnect the sensor cable from the monitor.
3. Select **Audio Pause** key to close the '**SpO₂ probe off**' alarm.

Setting SpO₂ alarms

1. Press the **SpO₂** key.
2. Select **SpO₂ Alarm**.
3. Select **Adjust Limits** to set up the limits.
4. Select **SpO₂ Alarm** to OFF/ON the limits.
5. You can also select **Alarms Setup** to adjust SpO₂ or related alarms.

GE Trusignal technology clinical studies on neonatal

GE Oxy-AF and GE Oxy-SE sensors have been validated for neonatal accuracy. The subject demographics included 28 neonates and 1 infant (15 females and 14 males). The subjects ranged in age from newborn to 37 days old. The weights ranged from 560 to 3060 g. The skin tones included in the study were light to dark. For neonatal study, the Arms of the collected convenience samples are 2.7, Oxy-AF sensor in the SaO₂ range of 87-100% collected 52 data points, Oxy-SE sensor in the SaO₂ range of 81-100% collected 53 data points.

Troubleshooting

- SpO₂ signal is poor:
 - Check the sensor and sensor positioning.
 - If in GE SpO₂ configuration, change the **SpO₂ Response** (averaging time) to **Normal**.
 - Note that skin pigment causes differences.
 - Make sure that the patient is not moving.

Non-invasive blood pressure (NIBP)

Safety precautions

Warnings

- The NIBP parameter will not measure blood pressure effectively on patients who are experiencing seizures or tremors.
- Arrhythmias will increase the time required by the NIBP parameter to determine a blood pressure and may extend the time beyond the capabilities of the parameter.
- Do not apply external pressure against the cuff while monitoring. Doing so may cause inaccurate blood pressure values.
- Do not place the cuff on a limb being used for A-V fistulas, intravenous infusion or on any area where circulation is compromised or has the potential to be compromised.
- Accuracy of NIBP measurement depends on using a cuff of the proper size. It is essential to measure the circumference of the limb and choose the proper size cuff.
- The cuff size selected in the NIBP menu and the cuff size used must be correct to obtain reliable NIBP data and to prevent overpressure in neonatal or pediatric use.
- For SuperSTAT™ NIBP Only - It takes one to three minutes for the NIBP parameter to identify an irregular rhythm after ECG is connected. For patients with irregular rhythms, simultaneous monitoring of ECG will enhance NIBP performance. Wait three minutes after ECG has been connected and ECG heart rate is present on the monitor screen before performing an NIBP determination.
- NBP READINGS MAY TIME OUT WHEN USING IABP - An IABP balloon pump creates non-physiologic arterial waveforms. These waveforms create an oscillometric signal that may not be interpreted, causing NIBP to time out. The patient blood pressure can be monitored from the balloon pump device.

- GE Healthcare monitors are designed for use with dual-hose cuffs and tubing. The use of single-hose cuffs with dual hose tubing can result in unreliable and inaccurate NIBP data.
- If a patient's beat-to-beat pulse amplitude varies significantly (e.g., because of pulsus alternans, atrial fibrillation, or the use of a rapid-cycling artificial ventilator), blood pressure and pulse rate readings can be erratic, and an alternate measuring method should be used for confirmation.
- If Luer lock connectors are used in the construction of tubing, there is a possibility that they might be inadvertently connected to intravascular fluid systems, allowing air to be pumped in to a blood vessel.

Cautions

- Devices that exert pressure on tissue have been associated with purpura, skin avulsion, compartmental syndrome, ischemia, and/or neuropathy. To minimize these potential problems, especially when monitoring at frequent intervals or over extended periods of time, make sure the cuff is applied appropriately and examine the cuff site and the limb distal to the cuff regularly for signs of impeded blood flow.
- Periodically check patient limb circulation distal to the cuff. Check frequently when using Auto NIBP in one and two minute intervals. The one and two minute intervals are not recommended for extended periods of time.
- The monitor sets the inflation pressure automatically according to the previous measurement. Reset the case or discharge the patient to reset the inflation limits before measuring NIBP on a new patient.

NIBP to patient connection

- (1) NIBP connector in monitor
- (2) Cuff hose
- (3) Cuff of correct size
- (4) Brachial artery arrow (printed on cuff)

- (5) Cuff index line (printed on cuff)

NOTE: For a comprehensive list of accessories, see the "Supplies and Accessories" catalog delivered with the monitor.

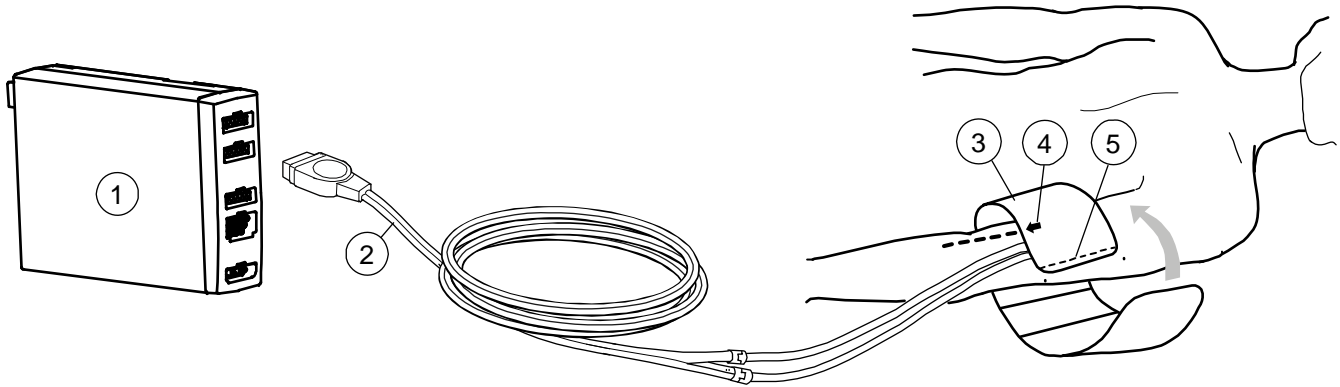

Preparing the patient for a NIBP measurement

1. Select an appropriate NIBP cuff size for the patient.
2. Connect the NIBP cuff hose to the module's NIBP connector.
3. To position the NIBP cuff on the patient:
 - Place the cuff arrow over the brachial artery (or whatever artery is being used).
 - Make sure that the cuff index line falls within the range markings on the cuff.
 - Wrap the cuff around the limb.
4. Make sure that the NIBP cuff tubes are not kinked, compressed, or stretched.
5. Press the **NIBP** key.
6. Verify or select the correct **Inflation Limits** from the **NIBP Setup** window.

NOTE: When **AUTO** is chosen, the initial inflation pressure is according to the cuff size you use. When the neonatal cuff size is in use, only **NEO** option is available.

NOTE: If the cuff hoses can't be detected automatically, the monitor will go to this selection automatically when you try to start the NIBP measurement. You must set the inflation limits manually. With these hoses, **AUTO** option is not available.

7. Verify or select the suitable measurement unit. The unit is selected during configuration through **Monitor Setup - Install/Service - Installation - Units**.

NOTE: The measurement unit may be mmHg or kPa.

To produce a single NIBP measurement

- From the keyboard
 - Press the **NIBP Start/Cancel** button in the Command Board
- From NIBP menu
 - Press the **NIBP** button and select **Start Manual**.

The Monitor beeps once to signal the completion of the determination and values are posted in Digit Fields.

To produce automatic NIBP measurements

To automatically measure NIBP at set time intervals, you must first set the cycle time before setting the automatic measurements.

You also can configure a custom auto mode to meet the need of your clinical situation.

Setting cycling intervals

1. Press the **NIBP** key.
2. Select **Cycle Time**.
3. Select the interval time from the list with the Trim Knob.
The possible intervals for autocycling are 1, 2, 3, 4, 5, 10, 15, 20, 30, 60, 90 or 120 minutes and custom option.

NOTE: When you select the custom option, the NIBP measurements will follow custom mode. You need to configure or verify the custom mode's set up before you start the automatic measurements.

Setting custom mode

You can set up to 4 separate steps for auto NIBP determinations by setting the time interval and how many times this interval is repeated.

1. Press the **NIBP** key.
2. Select **Custom Setup**.
3. Set up time interval and repeat times for every series.
The cycle time can be set to 1 to 120 min or OFF.
The repeat option can be set to 1 to 25 times or OFF or cont.

Starting and stopping NIBP Auto

- From the keyboard
 - Press the **NIBP Auto On/Off** button in the Command Board.
 - To stop the measurement, press the **NIBP Auto On/Off** button again.
- From NIBP menu
 - Press the **NIBP** key and select **Start Cycling**.
 - To stop the measurement, select the **Stop Cycling**.

To produce a STAT NIBP measurement

NOTE: Stat NIBP measurement is deactivated in neonatal mode.

To measure NIBP consecutively for 5 minutes:

- From the keyboard
 - To stop the measurement, press the **NIBP Start/Cancel** button again.
- From NIBP menu
 - Press the **NIBP** button and select **Start STAT**.
 - To stop the measurement, select the **Stop STAT**.

Adjusting the NIBP measurement completion tone volume

1. Press the **NIBP** key.
2. Select **NIBP Setup**.
3. Set the **Ready Prompt**

Setting NIBP alarms

1. Press the **NIBP** key.
2. Select **NIBP Alarm**.
3. Select **Adjust Limits** to set up the limits.
4. Select **Sys Alarm**, **Dia Alarm** or **Mean Alarm** to OFF/ON the limits.
5. You can also select **Alarms Setup** to adjust NIBP or related alarms.

During measurement

- Observe the cuffed limb frequently. Measurement may impair blood circulation. Intervals below 10 minutes and STAT measurements are not recommended for extended periods of time.
- Make sure that tubes are not bent, pressed or stretched. Measurement may be impaired.
- Blood pressure values may be affected by a change in the patient's position.
- The NIBP feature is not validated for pregnant, including pre-eclamptic patients use.

When 1 hour has passed from the latest NIBP measurement, the numeric value digits turn gray. When 4 hours has passed from the latest NIBP measurement, the gray numeric value digits are replaced by a dashed line.

NOTE: For the NIBP trends, the displayed and printed value is an average if there has been more than one NIBP measured in one minute. Except the Time Scale is 20' in Graphical trend.

Maintenance

For cuff cleaning and disinfection please refer to "[Cleaning and care](#)." or the instruction of related accessories.

Calibration and leak test of the parameter should be performed every 12 months or when there is doubt about the validity of the noninvasive blood pressure readings. Calibration and leak test should be performed by a qualified service person.

Principles of SuperSTAT Noninvasive Blood Pressure Determination

The oscillometric method of determining NIBP is accomplished by a sensitive transducer which measures cuff pressure and pressure oscillations within the cuff. For the first determination taken on a patient, the algorithm stores the pattern of the patient's oscillation size as a function of the pressure steps. For subsequent manual (determined as such when the previous determination is less than 16 minutes old), auto or STAT determinations taken on the same patient, as few as four pressure steps may be necessary to complete the determination process. When employing fewer pressure steps, the system uses the stored information from the previous blood pressure determination and picks the best of the pressure steps. The algorithm measures the consistency of pulse size to tell if the oscillations taken at a step are good and if more steps are needed.

The first determination settles at an initial target pressure of 135 mmHg (adult mode) and 100 mmHg (neonate mode), depending on initial target pressure preset. To allow for rapid settling of cuff pressure, the monitor will momentarily inflate to a higher pressure then immediately deflate to the target pressure. After inflating the cuff, the NIBP parameter begins to deflate. The oscillations versus cuff pressure are measured to determine the mean pressure and calculate the systolic and diastolic pressures.

During an NIBP determination, the parameter deflates the cuff one step each time it detects two pulsations of relatively equal amplitude. The time between deflation steps depends on the frequency of these matched pulses (pulse rate of the patient). However, if the monitor is unable to find any pulse within several seconds, it will deflate to the next step. The process of finding two matched pulses at each step provides artifact rejection due to

patient movement and greatly enhances the accuracy of the monitor. In stat mode, some steps may require only one pulse.

At each step the microprocessor stores cuff pressure, the matched pulse amplitude, and the time between successive pulses. The stepped deflation and matched pulse detection continues until diastolic pressure is determined or total cuff pressure falls below 8 mmHg. The parameter then deflates the cuff (to zero detected pressure), analyzes the stored data, and updates the screen.

The operating cycle is composed of four parts: inflation time, deflation time, evaluation time, and wait time. Wait time, which varies from mode to mode, is affected by the cycle time (auto mode) or operator intervention (manual mode).

Troubleshooting

- Measurement does not work or values seem unstable:
 - Check that cuff tubings are not bent, stretched, compressed or loose.
 - When using hoses without identification, make sure that you have selected the inflation limits in the **NIBP Setup** menu.
 - Prevent motion artifacts.
 - Use cuffs of correct size.

Invasive blood pressure

Safety precautions

Warnings

- All invasive procedures involve risks to the patient. Use aseptic technique. Follow catheter manufacturer's instructions.
- Make sure that no part of the patient connections touches any electrically conductive material including earth.
- Mechanical shock to the invasive blood pressure transducer may cause severe shifts in zero balance and calibration, and cause erroneous readings.
- When initializing the IBP parameter, Invasive blood pressure alarm activation criteria may result in inactive limit alarms.
- When using the electrosurgery unit, ensure proper contact of the ESU return electrode to the patient to avoid possible burns at monitor measurement sites. Also ensure that the ESU return electrode is near the operating area.

IBP equipment to patient connection

- (1) Compatible IBP measurement capability
- (2) Fluid bag or bottle with pressure infusor
- (3) Flushing set
- (4) Disposable catheter
- (5) Transducer
- (6) Adapter cable for the IBP transducer

- (7) Adapter cable for dual IBP measurement

You can monitor up to two pressure channels by using a dual cable.

NOTE: For a comprehensive list of sensors and accessories, see the "Supplies and Accessories" catalog.

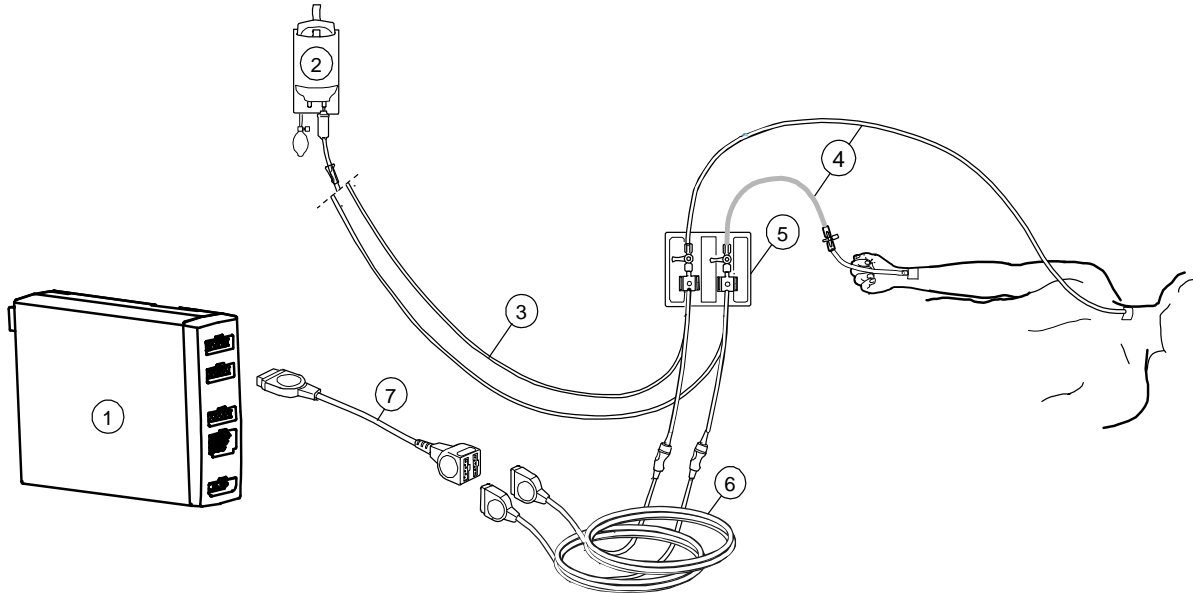

Preparing the patient for a IBP measurement

1. For the setup, prepare the transducer kit according to the manufacturer's instructions.
2. Remove entrapped air from with the transducer setup.
3. Zero the transducer by opening it to air, pressing the **IBP Zero All** command board key or the **IBP** monitor key and selecting **Zero Pressures - Zero ALL**. You can zero one channel at a time with selection **Zero IBP1** or **Zero IBP2**. Zero each channel.
NOTE: Selecting **Zero ALL** does not zero ICP. Zero it separately.
NOTE: The transducer is always leveled to the mid right atrium. Zero the transducer and pressures whenever the patient's position is changed.
4. Open the line to the patient.

NOTE: Invasive pressures need to be zeroed after reconnecting the pressure transducer or cable, and whenever patient's position is changed. If any channel has not been zeroed, the message 'InvBP's not zeroed' appears. The invasive pressure alarms advance to medium and high priority levels regardless of the zeroing.

NOTE: IBP transducers must comply with the requirements of IEC 60601-2-34, must be provided with defibrillator protection, have a frequency response exceeding 15Hz and contribute not more than 2mmHg to the overall measurement error.

Set up ventilation mode

Respiration causes artifacts in invasive pressures. At the end of expiration the artifact is at it's smallest.

1. Press the **IBP** key.
2. Select **Ventilation Mode**.
3. Select **Spont** for spontaneous respiration; select **Contrl** for controlled ventilation.

IBP channel setup

The label of the pressure channel sets its display scale, color, filter, alarm source and alarm limits. These selections are preconfigured according to the label you choose. You can adjust these settings also.

To select the label:

1. Press the **IBP** key.
2. Select **IBP1 Setup - Label** and **IBP2 Setup - Label**. For factory default descriptions, see next page.

Factory default descriptions

The channels have the following factory default descriptions:

LABEL	IBP1, Art, ABP	IBP2, CVP	RAP, LAP	ICP	PA	RVP	UAC	UVC
Scale mmHg/kPa	200/30	20/4	20/4	20/4	60/8	60/8	100/14	10/2
Color	Red	Blue	White	White	Yellow	White	Red	White
Alarm source	Sys	Mean	Off	Off	Off	Off	Sys, Dia, Mean	Mean
Digit format	S/D	Mean	Mean	CPP	S/D	S/D	S/D	Mean
Filter (Hz)	22	9	9	9	9	9	14	14
Response	Normal	Normal	Normal	Normal	Normal	Normal	Normal	Normal

Combining pressures

All invasive pressure waveforms can be displayed together so that they use an area of two normal waveforms, or so that all are combined in the same field with the same zero line.

1. Press the **Monitor Setup** key.
2. Select **Screen Setup**.
3. Select **Waveform Fields**.
 - To combine all pressure waveforms in one field, select **Combine Pressures** to **YES**.

Determining pressure values visually

By moving the horizontal cursor across the pressure waveform, you can get accurate pressure values at selected points. This may be useful, for example, if the patient's breathing pattern is irregular. The cursor is not available for pressures shown with a combined scale.

1. Press the **IBP** key.
2. Select **IBP1 Setup - IBP1 Cursor** and **IBP2 Setup - IBP2 Cursor**
3. Move the cursor up or down by turning the Trim Knob. Every time the cursor is moved, the time (hours and minutes) and pressure values appear on the screen. In this way you can keep track of the changes made.
4. You can remove the cursor by selecting **Remove Cursor**. Note that if the cursor is not removed, it remains visible on the Normal Screen.

Setting IBP alarms

1. Press the **IBP** key.
2. Select **IBP1 Setup - IBP1 Alarm** and **IBP2 Setup - IBP2 Alarm**.
3. Select **Adjust Limits** to set up the limits.
4. Select **Sys Alarm, Dia Alarm** or **Mean Alarm** to OFF/ON the limits.
5. You can also select **Alarms Setup** to adjust IBP or related alarms.

Troubleshooting

- Readings seem unstable:
 - Make sure that there are no air bubbles in the transducer system.
 - Flush and zero.
 - Place the transducer on the patient's mid-heart level and zero.
- Invasive blood pressure waveform is displayed but no numeric values are displayed:
 - Zero the channel. Invasive blood pressure numerical values are displayed only for successfully zeroed channels.

Temperature

Safety precautions

Warnings

- Temperature measurement response time is affected by use of esophageal stethoscope with certain temperature sensors.

Caution

- When using the electrosurgery unit, ensure proper contact of the ESU return electrode to the patient to avoid possible burns at monitor measurement sites. Also ensure that the ESU return electrode is near the operating area.

NOTE: Temperature measurement response time is affected by use of esophageal stethoscope with certain temperature sensors.

Temperature equipment to patient connection

- (1) Compatible temperature measurement capability
- (2) Adapter cable for temperature probes
- (3) Reusable temperature probe
- (4) Adapter cable for disposable temperature probes
- (5) Disposable temperature probe

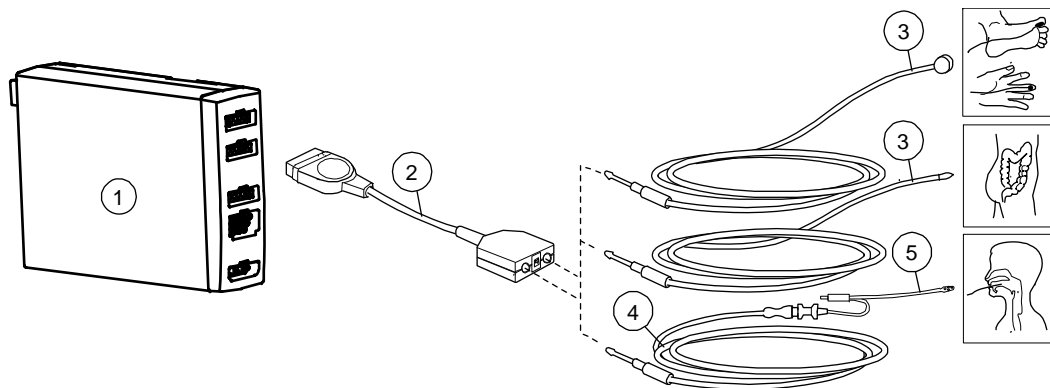

Preparing the patient for a temperature measurement

1. Follow the manufacturer's instructions for probe application and instructions.
2. Connect the adapter cable to the acquisition module connector.

Changing the temperature label

The monitor support 2 channel temperature measurement. You can setup the label names.

1. Press the **Others** key.
2. Select **Temp Setup - T1 Label** or **T2 Label**.

Changing temperature units

You can select the temperature units to be either degrees Celsius or degrees Fahrenheit:

1. Press the **Others** key.
2. Select **Temp Setup**.
3. Select **Unit** and then **°C** or **°F** with the Trim Knob.

Combining different temperatures

The monitor can display the delta value between different temperatures if they are displayed in the same digit field.

For example, to display $T2 - T1$:

1. Press the **Monitor Setup** key.
2. Select **Screen Setup**.
3. Select **Digit Fields**.
4. Select **T1+T2** to one of the lower fields.

Setting temperature alarms

1. Press the **Others** key.
2. Select **Temp Setup**, choose **Temp Alarms**.
3. Select **Adjust Limits** to set up the limits.
4. Select **T1 Alarm, T2 Alarm** to OFF/ON the limits.
5. You can also select **Alarms Setup** to adjust Temperature or related alarms.

Troubleshooting

- Measurement fails:
 - Check that the probe is properly connected to the probe adapter.
 - Check that you are using the correct probe for the anatomical location being monitored.
 - Use a probe that is compatible with your system.
 - Try using a known good probe in case the sensor is damaged.
 - Check the patient connection.

Airway gas

Safety precautions

Warnings

- Always check the airway adapter for a tight connection and proper operation before attaching it to the patient.
 - Remove the airway gas sampling line from the patient's airway while nebulized medications are being delivered.
 - Keep the monitor horizontal when the gas module is used. Tilting the monitor may cause erroneous results in the gas module's readings and damage the module.
 - Leak in breathing circuit (water trap and sampling line) may cause inaccurate readings.
 - Blocked gas exhaust may cause inaccurate readings.
 - EtCO₂ values may differ from blood gas readings.
 - Be sure gas or CO₂ measurement is off before removing water trap.
 - Never connect any tubing to reference gas inlet connector. The inlet must be open at all times.
 - Strong scavenging suction may change the operating pressure of the module and cause inaccurate readings or excessive sample gas flow.
 - Do not use gas or CO₂ sidestream sampling modules on patients who may be adversely affected by the specified withdrawal rates (e.g. a neonate with low tidal volume).
 - To avoid the spread of infectious disease, do not allow the exhaust to discharge in the direction of the patient or user.
 - Handle the water trap and its contents as you would any body fluid. Infectious hazard may be present.
 - E-miniC measurement is intended for patients weighing over 5 kg (11 lb).
- Since sample gas may contain anesthetic agents, make sure that it is not released in the room. Connect the exhaust to a scavenging system to prevent exposure to anesthetic agents.
 - Always ensure the correct size and fit of accessories according to patient type and application, especially when monitoring pediatric and neonatal patients. The size and fit of accessories may impact the measured gas concentration values at low tidal volumes. It is recommended to have the gas sampling port close to the proximal end of the endotracheal tube. Excessive dead space in the circuit, including the accessories, may cause re-breathing of gases. Very low accessory dead space between the breathing circuit Y-piece and the gas sampling site may impact the measured gas concentration due to dilution of the sampled exhaled gas with fresh gas from the ventilator. To confirm accurate correlation with measured gases and blood, check arterial blood gas values to confirm a suitable setup is used.
 - When monitoring neonatal or other patients that have high respiration rate or low tidal volume these modules shall be used within the limits of respiration rates and tidal volumes to ensure specified measurement accuracy.
 - When using the CARESCAPE respiratory modules and Airway Gas Option module with volume controlled ventilation at low tidal volumes, the specified gas withdrawal rate may significantly reduce the amount of gas delivered to the patient.
 - CARESCAPE respiratory modules and Airway Gas Option: Make sure to compensate for the possible reduction of tidal volume caused by the 120 ml/min gas sample flow.
 - E-miniC module: Do not use this module on patients that cannot tolerate the removal of 150 ml/min from their total minute ventilation

- A failure in zeroing or calibrating airway gases may cause inaccurate readings.
- E-miniC module: O₂, N₂O and anesthetic agent gases may interfere with EtCO₂ readings.
- EQUIPMENT FAILURE OR INACCURATE READINGS — Planned maintenance should be carried out annually according to the instructions given in the technical manual. Failure to implement the recommended maintenance schedule may cause equipment failure or inaccurate readings.
- PATIENT CROSS-INFECTION — Returning the sampled gas to the patient circuit causes a risk of patient cross-infection.
- PATIENT CROSS-INFECTION — Always use a bacterial breathing system filter proximal to the patient when returning the sampled gas to the patient circuit. If a bacterial breathing system filter is not used, a failure in the D-Fend Pro water trap may cause a risk of patient crossinfection.
- PATIENT CROSS-INFECTION — If the sampled gas is returned to the patient circuit, ensure the protective function of the D-Fend Pro water trap by replacing it at least once a week, or immediately in case of a defective or missing bacterial breathing system filter. Otherwise, there is a risk of patient cross-infection.
- When use Airway Gas Option module (N-CAiO) for anesthetic agent measurement, make sure the agent is no more than one.

Cautions

- Do not apply pressurized air or gas to any outlet or tubing connected to the monitor, pressure may destroy sensitive elements.
- Patient-specific MAC is affected by several factors such as patient age and body temperature.

Airway gas measurement limitations

- E-miniC measurement is intended for patients weighing over 5 kg (11 lb).

Alternative airway gases modules

The E-miniC, CARESCAPE Respiratory Module (E-sCO and E-sCAiO modules) and Airway Gas Option (N-CAiO module) provide airway measurements. Letters in these module name stand for:

C=CO₂ and N₂O, O=patient O₂, A=anesthetic agents and i=agent identification

The following tables show the airway gases for each acquisition module. The "X" indicates that the module measures the listed parameter.

Module	Parameters/measurements					Additional measurements			
	CO ₂	N ₂ O	O ₂	Anesthetic agents	Agent ID	MAC	MACage	Balance Gas	Respiration rate
E-miniC	X								X
E-sCO	X	X	X						X
E-sCAiO	X	X	X	X	X	X	X	X	X
N-CAiO	X	X	X	X	X	X			X

NOTE: The CARESCAPE Respiratory Module and Airway Gas Option automatically compensate for N₂O in realtime. The E-miniC requires manual selection from the monitor menu to compensate for N₂O.

NOTE: When monitoring neonatal or other patients that have high respiration rate or low tidal volume, The CARESCAPE Respiratory Module and Airway Gas Option shall be used within the limits of respiration rates and tidal volumes to ensure specified measurement accuracy.

NOTE: The monitor also is compatible with the E-sCOV and E-sCAiOV modules, but the patient spirometry function can't be used.

E-miniC module to patient connection

- (1) E-miniC module
- (2) Gas sampling line
- (3) Airway adapter with sampling line connector
- (4) Sampling line connector on the water trap

NOTE: For a comprehensive list of accessories, see the "Supplies and Accessories" catalog.

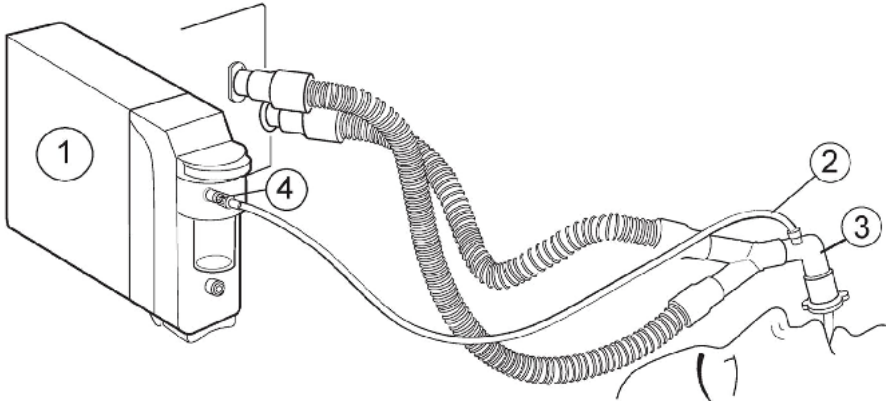

CARESCAPE Respiratory Module or Airway Gas Option to patient connection

- (1) E-sCO₂, E-sCAiO or N-CAiO module
- (2) Gas sample, gas sampling line connector on the water trap
- (3) Gas sampling line
- (4) Gas sampling line connector on the airway adapter; place the connector upwards
- (5) Airway adapter with sampling line connector
- (6) Heat and moisture exchanger with filter (HMEF) (optional)

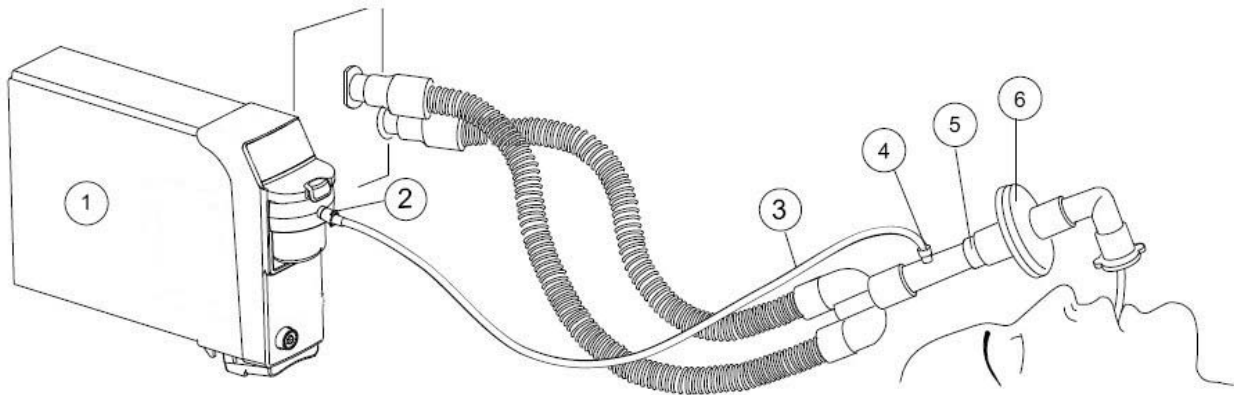

Preparing for a gas measurement

1. Make sure that the water trap container is empty and properly attached.
2. Connect the gas sampling line to the sampling line connector on the water trap.
3. Connect the sample gas outlet to gas scavenging if N₂O or volatile agents are used.
4. Turn on the monitor. The monitor performs a self-check. Make sure the related gas measurement is **ON**.
5. Wait until the message '*Calibrating gas sensor*' disappears.
6. Connect the sampling line to the airway adapter or the airway adapter to the ventilator circuit. Position the adapter with the sampling port upwards to minimize the amount of condensed water possibly entering the sampling line.
7. Check that the airway adapter connections are tight and that the adapter is operating properly.
8. If E-miniC is used with O₂ and/or N₂O contents higher than 40%, make sure that **FiO₂ Level** and **N₂O Level** are set.

NOTE: Check that the sample line is connected to the water trap before connecting the module to the monitor or turning on the monitor.

NOTE: To minimize the amount of dust drawn into the gas sampling system, always keep the water trap connected to the module. When gas measurement is not in use, you can disconnect the module from the monitor to eliminate the operating sound of the gas pump.

CO₂ measurement

Selecting the CO₂ scale

If EtCO₂ is above 6% or the difference between FiO₂ and EtO₂ is above 6%, change the scale for capnogram:

1. Press the **Airway Gas** key.
2. Select **CO₂ Setup**.
3. Select **Scale**

Selecting the FiO₂ level

The presence of a large concentration of oxygen causes the CO₂ level appear lower than the actual value. Use this option to compensate for the presence of O₂.

1. Press the **Airway Gas** key.
2. Select **CO₂ Setup**.
3. Select **FiO₂ Level**.

Selecting the N₂O level

The presence of N₂O causes the CO₂ value to appear higher than the actual value. Use this option to compensate for the presence of N₂O.

1. Press the **Airway Gas** key.
2. Select **CO₂ Setup**.
3. Select **N₂O Level**.

Changing the units

You can use %, kPa or mmHg as the CO₂ measurement units. The units can be changed in the **CO₂ Setup** menu:

1. Press the **Airway Gas** key.
2. Select **CO₂ Setup - Unit**.
3. Choose the option.

Selecting the source of respiration

You can select the respiration rate's source

1. Press the **Airway Gas** key.
2. Select **CO₂ Setup - Resp Rate Source**.
3. Choose the option.

NOTE: If you select **AUTO**, the rate is calculated from the measured CO₂.

OFF/ON the CO₂ measurement

1. Press the **Airway Gas** key.
2. Select **CO₂ Setup - Measurement**.
3. Choose **OFF** or **ON**

Setting alarms

Setting CO₂ alarms

1. Press the **Airway Gas** key.
2. Select **CO₂ Setup - CO₂ Alarm**.
3. Select **Adjust Limits** to set up the limits.
4. Select **EtCO₂ Alarm, FiCO₂ Alarm** to OFF/ON the limits.
5. You can also select **Alarms Setup** to adjust CO₂ or related alarms.

Setting respiration rate alarms

1. Press the **Airway Gas** key.
2. Select **CO₂ Setup - Resp Rate Alarm**.
3. Select **Adjust Limits** to set up the limits.
4. Select **RR Alarm**, to OFF/ON the limits.
5. You can also select **Alarms Setup** to adjust RR or related alarms.

O₂ measurement

NOTE: B40 only.

Selecting the O₂ scale

If the difference between FiO₂ and EtO₂ is above 6%, change the O₂ scale:

1. Press the **Airway Gas** key.
2. Select **O2 Setup**.
3. Select **Scale**
4. Select an option from the scale list.

OFF/ON the O₂ measurement

1. Press the **Airway Gas** key.
2. Select **O2 Setup - Measurement**.
3. Choose **OFF** or **ON**

Setting O₂ alarms

1. Press the **Airway Gas** key.
2. Select **O2 Setup - O2 Alarm**.
3. Select **Adjust Limits** to set up the limits.
4. Select **EtO2 Alarm, FiO2 Alarm** to OFF/ON the limits.
5. You can also select **Alarms Setup** to adjust O₂ or related alarms.

Anesthetic agent and N₂O measurement

NOTE: B40 only.

NOTE: The E-sCAiO and N-CAiO modules automatically identify the agent being used. If the agent value is out of measurement range, "---" will be displayed on screen, which means the value is invalid.

Selecting the agent scale

1. Press the **Airway Gas** key.
2. Select **Agent/N2O Setup - Agent Scale**
3. Select an option from the scale list.

OFF/ON the agent measurement

1. Press the **Airway Gas** key.
2. Select **Agent/N2O Setup - Agent Measurement**.
3. Choose **OFF** or **ON**

OFF/ON the N₂O measurement

1. Press the **Airway Gas** key.
2. Select **Agent/N2O Setup - N2O Measurement**.
3. Choose **OFF** or **ON**

Setting agent alarms

1. Press the **Airway Gas** key.
2. Select **Agent/N2O Setup - Agent Alarm**.
3. Select **Adjust Limits** to set up the limits.
4. Select **EtAA Alarm, FiAA Alarm** to OFF/ON the limits.
5. You can also select **Alarms Setup** to adjust agent or related alarms.

Minimum Alveolar Concentration (MAC) and balance gas

NOTE: B40 only.

The minimum alveolar concentration (MAC) concept is based on the assumption that in a steady state, the alveolar partial pressure of a gas is equal to the partial pressure in the effector organ of the central nervous system. MAC values are used to estimate the level of anesthesia caused by volatile anesthetics. The MACage takes patient's age and temperature into account.

End-tidal balance gas (EtBal) is the percentage of gas concentration not measured by the gas sensors. An increased balance gas value may indicate the amount of nitrogen flushed out from the patient into the circuit. The increase may be due to an accumulation of nitrogen during low flow anesthesia.

The MAC/MACage and balance gas can be selected during digit fields set up and are displayed in the digit fields of the monitor.

Airway gases calculations

- $$\text{MAC} = \frac{\text{EtAA}_1(\%)}{x(\text{AA}_1)} + \frac{\text{EtAA}_2(\%)}{x(\text{AA}_2)} + \frac{\text{EtN}_2\text{O}(\%)}{100}$$

where AA₁=primary agent, AA₂=secondary agent, x(AA) is Hal=0.75%, Enf=1.7%, Iso=1.15%, Sev=2.05%, Des=6.0% and N₂O=100%.

- **MACage (volatile agent)** = (0.05T-0.85) A (1.32 × 10^{-0.00303age})
where T=temperature, A=MAC

- **MACage (N2O)** =
$$\frac{\text{atmN}_2\text{O}}{1.14(1.378 \times 10^{-0.00347age})}$$

- **Balance gas (EtBal)** = 100 - EtCO₂ - EtO₂ - EtN₂O - EtAA_(pri) - EtAA_(sec)
where EtAA_(pri) and EtAA_(sec) are the primary and secondary end tidal values for the measured anesthetic agent.

To select the MAC type

1. Press **Monitor Setup** key.
2. Select **Install/Service** and enter the password.
3. Select **Installation - Monitor Settings - Parameter Settings**.
4. Select **MAC Type**.

To enable the MACage calculation:

- Give the patient's age in menu **Admit/Discharge - Admit Patient - Demographics**.
- Attach a temperature sensor.

If the patient's age is not given, the monitor shows normal MAC even if MACage has been selected.

NOTE: The MAC value displayed by the monitor is that of exhaled air, and it does not always correspond to the amount of anesthetic in the patient's organs.

NOTE: If oxygen or CO₂ status is invalid or agent identification fails, the monitor displays the balance gas value as invalid.

Automatic agent identification with E-sCAiO, N-CAiO modules

NOTE: B40 only.

The modules with agent identification option will automatically identify and select Isoflurane, Desflurane, Sevoflurane, Enflurane and Halothane. The E-sCAiO module is able to identify two agents simultaneously and displaying them as primary and secondary agents. The N-CAiO module is able to identify and display one agent. The inspiratory and expiratory concentrations of the agent are displayed in digit field. Minimum concentration for the identification is 0.15 vol%. The agent selection remains active even if the concentration decreases below 0.15 vol%. Automatic agent identification is operational after the normal warm up of the module (approximately five minutes).

- If rapid agent concentration changes are required, fresh gas flow must be increased.
- Anesthetic agent concentration in the circuit is affected by patient uptake, breathing system volume and the fresh gas flow. It quantifies the speed of wash-in and wash-out anesthetic agents.

During monitoring

- Empty the water trap container when half full. Follow local hospital's regulations to dispose the accumulated fluids.
- Disconnect the airway adapter during nebulization of medications.

NOTE: When the measured CO₂ value is outside the specified measurement range, the numeric value is gray.

Points to note

- Make sure that you are using a water trap that is compatible with the module:
 - E-sCO, E-sCAiO and N-CAiO modules: D-fend Pro or D-fend Pro+
 - E-miniC: Mini D-fend
- Empty the water trap container as soon as it is more than half full. With a sample gas temperature of 37°C, a room temperature of 23°C, and sample gas relative humidity of 100 %RH, the water trap should be emptied every 24 hours (applies when the sample gas flow is within 120 ± 20 ml/min for E-sCO, E-sCAiO and N-CAiO, 150 ± 25 ml/min for E-miniC).
- Place the airway adapter between the HME and Y-piece.
- Place the airway adapter with all sampling ports upwards.
- Always check the tightness of all connections.
- Make sure that the gas sampling line is properly connected to the water trap and the water trap is properly connected to the airway gas module. Gas leaks in these connections may dilute the gas sample from the patient circuit, thus resulting in erroneous gas readings. During normal operation, all sampled gas flows out of the sample gas outlet. Room air is used as reference gas for the oxygen measurement and it is mixed with the sampled gas. The sampled gas is diluted by room air so that the fraction of room air in the exhaust gas is about 20%.
- Calibrate the airway gas module every six months in normal use and every two months in continuous use, see "[Cleaning and care](#)."

Disposal of gases

When N₂O and volatile anesthetics are used, prevent operating room pollution by connecting the sample gas outlet (gas exhaust) of the module to the scavenging system. Follow local hospital's regulations.

Scavenging through the ventilator reservoir

1. Connect an exhaust line to the sample gas outlet (gas exhaust) on the module's front panel.
2. Attach the other end of the line to the ventilator reservoir. Make sure that the reservoir tube diameter is at least 2 to 3 times larger than the exhaust line.

Scavenging through the anesthesia gas scavenging system

Anesthesia machines are equipped with an anesthesia gas scavenging system (AGSS), and in some machines you can connect the sample gas outlet directly to it. See the anesthesia machine's user documentation to find out where and how the sample gas can be connected.

Connecting directly to the scavenging system

1. Connect the exhaust line to the monitor's sample gas outlet.
2. Connect the exhaust line only to an open scavenging system where gas is removed at room pressure.

NOTE: Do not connect the monitor directly to a strong vacuum scavenging system.

NOTE: If the E-miniC is used, do not return sample gas to the patient circuit.

Troubleshooting

- Values are too low:
 - Check the sampling line and connectors for leakage.
 - Check the patient status.
- Values are too high:
 - Check the sampling line for blockage.
 - Check the patient status.
- Module does not work:
 - Check and clean the filter if necessary.
 - Check the water trap. If it was too full, liquid may have entered the module. Replace the module and have it checked by authorized service personnel.
- No airway gas values:
 - Check that the gas sampling line is connected to the water trap.

Entropy

Safety precautions

Warnings

- Make sure that the electrodes, sensor and connectors do not touch any electrically conductive material, including earth.
- DEFIBRILLATOR PRECAUTIONS - Patient signal inputs labeled with the CF and BF symbols with paddles are protected against damage resulting from defibrillation voltages. To ensure proper defibrillator protection, use only the recommended cables and leadwires. Do not reuse the single-use entropy electrodes.
- DEFIBRILLATOR PRECAUTIONS - Proper placement of defibrillator pads in relation to the electrodes is required to ensure successful defibrillation.
- In case of spill, take device out of service and have it checked.

Cautions

- When using an electrosurgery unit, ensure proper contact of the ESU return electrode to the patient to avoid burns at the monitor measurement sites. Also ensure that the ESU return electrode is near the operating area.
- Strong 30-40 Hz magnetic fields may cause erroneous Entropy measurement. Do not use devices with such a field close to the module or sensor.
- The Entropy measurement is always to be used only as an adjunct to other physiological parameters. Clinicians are advised to use their knowledge and experience when making clinical judgements. Entropy values are not to be used as sole indicators of the patient status.
- Check the sensor expiration date on the sensor package. Do not use expired sensors. Do not use a sensor for more than 24 hours.

Note

- Automatic sensor check may need to be disabled if the 70 Hz impedance check signal interferes with other equipment, such as EEG module with evoked potentials measurement.
- The device is not compatible with M-ENTROPY module.

Entropy measurement limitations

- Entropy measurement is not indicated for pediatric patients younger than two years old.
- Entropy is not validated with patients undergoing sedation.
- Unusual or excessive electrical interference is a potential cause for artifact. During extended periods of electrocautery there may not be any good EEG epochs, and Entropy values will not be displayed.
- ECG, frequent eye movements, coughing, muscle rigidity and patient movement cause artifact and may interfere with the measurement. Epileptic episodes may also cause interference.
- Entropy readings may be inconsistent when monitoring patients with neurological disorders, traumas or their sequelae.
- Entropy readings may be inconsistent when using benzodiazepines, nitrous oxide or ketamine as anesthetics.
- Psychoactive medication or very high opiate doses may suppress EEG and cause inconsistent Entropy readings.
- Cooling the patient may suppress their EEG and cause inconsistent Entropy readings.

Entropy equipment to patient connection

- (1) Module with Entropy measurement capability
- (2) GE Entropy sensor cable
- (3) GE Entropy sensor, or
- (4) Entropy sensor

NOTE: A portion of the Entropy software is derived from the RSA Data Security, Inc. MD5 Message-Digest Algorithm.

NOTE: Entropy sensors are latex and PVC free, disposable and for single-patient use only.

NOTE: For a comprehensive list of accessories, see the "Supplies and Accessories" catalog.

Entropy module keys

There are two keys on the module:

Entropy	Opens or closes the Entropy menu on the screen
Check Sensor	Starts the manual sensor check

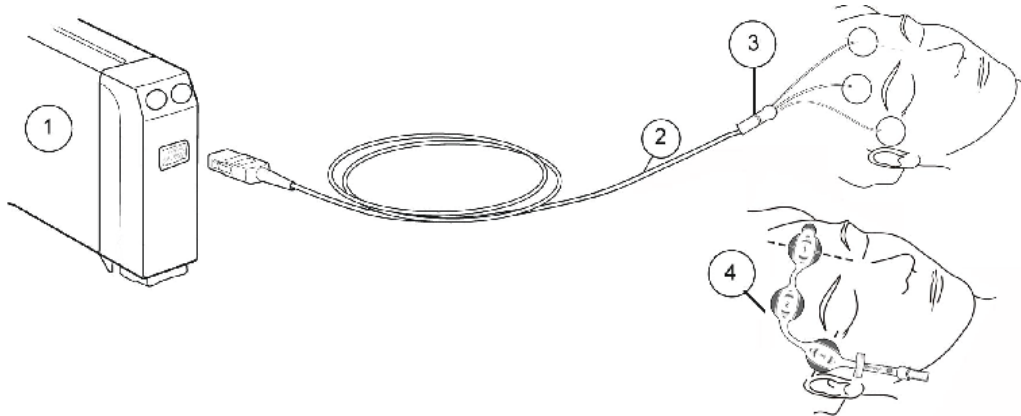

Preparing for Entropy measurement

1. Connect the Entropy sensor cable to the module.
2. Clean the application site according to the sensor's instructions for use and let it dry before attaching the sensor.
3. Place the Entropy sensor on the patient's forehead; see sensor package for instructions.
4. Connect the sensor to the Entropy sensor cable.
5. Observe the results of the automatic sensor check in the parameter window.
6. The measurement starts automatically after the sensor has passed the check.

Entropy points to note

- Entropy sensors are latex- and PVC-free, disposable and for single-patient use only.
- Make sure that the sensor connectors of the sensor cable are not in contact with fluids.
- Always ensure that the sensor is properly attached to the patient and connected to the cable.
- In **NEONATAL** mode, the entropy function will be disabled and the related menu is gray.

Entropy measurement checks

- Check that the sensor/electrode passes the sensor/electrode check when you are starting to monitor a new patient.

Selecting the EEG scale

This selection affects the Entropy waveform and snapshots:

1. Press the **Entropy** module key, or press the **Others** key, select **Entropy**
2. Select **Entr.EEG Scale**.
3. Select a value from the scale list.

Selecting the Entropy trend length

1. Press the **Entropy** module key, or press the **Others** key, select **Entropy**
2. Select **Trend Length** and choose an option.

This option only influences the length of the trend shown in horizontal digit field.

Selecting the display format for Entropy

You can select which Entropy parameters are shown in realtime, trends, recording and printing.

1. Press the **Entropy** module key, or press the **Others** key, select **Entropy**
2. Select **Display Format** and choose an option.
 - **RE** = Response Entropy
 - **SE** = State Entropy
 - **RE+SE** = both of the above
 - **All** = RE, SE and Burst Suppression Ratio (BSR)

Using the manual Entropy sensor check

Whenever required, you can perform the sensor check manually.

1. Press the **Check Sensor** module key, or:
 - Press the **Entropy** module key, or press the **Others** key, select **Entropy**
 - Select **Check Sensor**.
2. Observe the results on the screen. Do not press the sensor during the check to avoid signal noise.
3. The measurement continues automatically after the sensor has passed the check.

Bypassing the Entropy sensor check

If the sensor does not pass the impedance check, this option becomes selectable. It allows you to start the measurement without completing the sensor check.

NOTE: In this case, the measurement may be unreliable.

1. Press the **Entropy** module key, or press the **Others** key, select **Entropy**
2. Select **Bypass Check**.

Using the automatic Entropy sensor check

To take the automatic sensor check into use, the monitor will check the sensor every 10 minutes.

1. Press the **Entropy** module key, or press the **Others** key, select **Entropy**
2. Select **Automatic Check** to ON/OFF.

NOTE: This menu doesn't influence the initial check, the system will automatically do the self check once patient connect.

Setting Entropy alarms

1. Press the **Entropy** module key, or press the **Others** key, select **Entropy**
2. Select **Entropy Alarms**.
3. Select **Adjust Limits** to set up the limits.
4. Select **RE Alarm, SE Alarm** to OFF/ON the limits.
5. You can also select **Alarms Setup** to adjust Entropy or related alarms.

Stopping the Entropy measurement

1. Remove the Entropy sensor from the patient.
2. Disconnect the sensor from the sensor cable.
3. Discard the sensor.

Troubleshooting

- Entropy values seem unstable:
 - Check that the sensor is not dried out.
 - Check the sensor attachment and placement.
 - Check the patient status.
- Entropy EEG signal is noisy:
 - Remove disturbing equipment from the proximity of the Entropy module or sensor.
 - Check the sensor's contact with skin.
 - Check electrodes.
- Entropy EEG signal is poor:
 - Check the sensor's contact with skin.
 - Check electrodes.
- Entropy waveform and numbers do not correspond:
 - Check raw EEG as impedance check may cause a temporary increase in the numeric values.
 - Check the patient's overall status.
- Entropy readings seem inconsistent with the patient status:
 - Check raw EEG for QRS or other artifact.
 - Check electrode placement.

For your notes:

Troubleshooting

NOTE: Always check the patient's condition first in problematic situations or if an alarm is triggered. See also "Messages." Also note that if the measurement or function does not appear on the screen, check module connections.

Airway gases

Values are too low:

- Check the sampling line and connectors for leakage.
- Check the patient status.

Values are too high:

- Check the sampling line for blockage.
- Check the patient status.

Module does not work:

- Check and clean the filter if necessary.
- Check the water trap. If it was too full, liquid may have entered the module. Replace the module and have it checked by authorized service personnel.

No airway gas values:

- Check that the gas sampling line is connected to the water trap.

Arrhythmia

Extra arrhythmias are detected.

- Start relearning manually through **ECG - Relearn**.

Extra Ventricular Fibrillations are detected:

- Check the patient.
- Check that the amplitude signals are sufficient:
Leads I and II: Select the one with the largest amplitude to ECG 1.
After selecting the leads, start relearning manually.

Batteries

Battery operation time is markedly shortened:

- Condition the batteries, see "[Conditioning the batteries](#)" and the "User's Reference Manual."

ECG

ECG signal is noisy or no QRS is detected:

- Ensure that the patient is not shivering.
- Select the correct ECG filter through **ECG - ECG Setup - Filter**.
- Check the electrode quality and positioning. Do not place them on body hair, bones close to skin, layers of fat and major muscles. Pre-gelled electrodes are recommended.
- Change the ECG lead.
- Remove the ECG cable from the module and reinsert it.

Entropy

Entropy values seem unstable:

- Check that the sensor is not dried out.
- Check the sensor attachment and placement.
- Check the patient status.

Entropy EEG signal is noisy:

- Remove disturbing equipment from the proximity of the Entropy module or sensor.
- Check the sensor's contact with skin.
- Check electrodes.

Entropy EEG signal is poor:

- Check the sensor's contact with skin.
- Check electrodes.

Entropy waveform and numbers do not correspond:

- Check raw EEG as impedance check may cause a temporary increase in the numeric values.
- Check the patient's overall status.

Entropy readings seem inconsistent with the patient status:

- Check raw EEG for QRS or other artifact.
- Check electrode placement.

Impedance respiration

Measurement fails:

- Check the electrode quality and positioning.
- Adjust the detection limits. During ventilator supported breathing, the respiration calculation may count only ventilator-produced inspirations and expirations.
- Other electrical devices may interfere with the measurement.

Invasive pressures

Readings seem unstable:

- Make sure that there are no air bubbles in the transducer system.
- Flush and zero.
- Place the transducer on the patient's mid-heart level and zero.

Invasive blood pressure waveform is displayed but no numeric values are displayed:

- Zero the channel. Invasive blood pressure numerical values are displayed only for successfully zeroed channels.

Monitor

The monitor does not start:

- Check that the batteries are inserted and sufficiently charged, see page [25](#).
- Check that the power cord is properly connected.
- Check the fuses and replace them if necessary, see "Cleaning and care."

Measurements

The measured values are not displayed:

- Check that you have selected the desired parameter to a waveform or digit field, see "[Modifying the screen setup.](#)"

You cannot perform a measurement or a function.

- Check that the measurement module is properly installed.
- Remove the module and reinstall it.

Printing

Printing is not possible:

- Check the printer setting through **Print/Record - Printer Connection**.
- Check that the printer is connected to the network.
- Check the network cable.

Recording

Recording is not possible:

- Check the Central recorder if you are recording through network.

Non-invasive blood pressure

Measurement does not work or values seem unstable:

- Check that cuff tubings are not bent, stretched, compressed or loose.
- When using hoses without identification, make sure that you have selected the inflation limits in the **NIBP Setup** menu, see "[Non-invasive blood pressure \(NIBP\)](#)."
- Prevent motion artifacts.
- Use cuffs of correct size.

Pulse oximetry

SpO₂ signal is poor:

- Check the sensor and sensor positioning.
- If in GE SpO₂ configuration, change the **SpO₂ Response** (averaging time) to **Normal**.
- Note that skin pigment causes differences.
- Make sure that the patient is not moving.

Temperature

Measurement fails:

- Check that the probe is properly connected to the probe adapter.
- Check that you are using the correct probe for the anatomical location being monitored.
- Use a probe that is compatible with your system.
- Try using a known good probe in case the sensor is damaged.
- Check the patient connection.

Messages

Always check the patient first. If any problem or message persists, contact qualified service personnel. Messages are listed here in alphabetical order.

- **Agent Mixture**
 - Mixture of halogenated agents is detected. Check the ventilator and agent vaporizer settings.
- **Alarm setup changed from Central**
 - Check the alarm limits and the arrhythmia alarm priorities, see [“Alarms”](#) and [“ECG.”](#)
- **Alarms silenced from Central**
 - If required, turn on the bedside alarms through **Alarms Setup - Audio ON/OFF - Activate Alarms.**
- **Alarm volume changed**
 - The network connection is lost, and the local alarm volume is increased. Readjust volume if desired.
- **Apnea/No Breath**
 - Check the patient status.
 - Check the ventilator and breathing circuit.
- **Arrhythmia Paused**
 - ECG: Check the patient status. Check the electrodes.
- **Art disconnect/ABP disconnect/UAC disconnect**
 - IBP: Check the patient status.
 - Check the Art/ABP/UAC line.
- **Asystole**
 - Check the patient status.
 - Check the electrodes.
- **Battery A temperature high, Battery B temperature high**
 - Replace the battery.
 - If the problem persists, contact authorized service personnel.
- **Battery empty, Battery low**
 - Replace the battery, see [“Replacing the batteries”](#), or connect the monitor to power outlet.
- **Brady**
 - Check the patient status.
- **Call service: UMBC error**
 - UMBC: Contact authorized service personnel.
- **Check D-Fend**
 - Check that the water trap is properly attached to the module.
- **Check OCRG**
 - New OCRG snapshot is created, please check.
- **Check NIBP**
 - Check the patient status.
 - Check the measurement setup.
 - Check the cuff and hoses.

- **Check SpO2 probe**
 - SpO₂: Check the sensor and connections.
- **Check sample gas out**
 - Gases: Remove blockage from the sample gas outlet.
- **Condition Battery A, Condition Battery B**
 - Condition the battery according to the instructions of the external charger.
- **Creating OCRG snapshot**
 - In neonatal mode, the value of HR, SpO₂ or Apnea time is out of limits.
- **Default settings returned.**
 - Check your power and reset the settings.
- **DEMO MODE**
 - DEMO mode is active.
- **ECG module error**
 - Contact authorized service personnel.
- **End of 20 min trend data**
 - Check the graphical trends and move the cursor.
- **Entropy cable off**
 - Connect the Entropy cable to the Entropy module.
- **Entropy sensor off**
 - Check that the sensor is properly attached to the patient.
- **Entropy sensor check failed**
 - Check sensor placement and attachment.
 - Press each electrode in the sensor.
 - Replace the sensor.
- **Frame temperature high**
 - Make sure there is sufficient ventilation.
 - If the problem persists, contact authorized service personnel.
 - Turn off the monitor, wait for it cool down.
- **Freq PVCs**
 - Check the patient status.
- **Incompatible SpO2 Probe**
 - Replace the sensor.
 - If the problem persists, contact authorized service personnel.
- **InvBP's not zeroed**
 - Zero the channel indicated or zero both channels.
- **Leads off**
 - ECG: Reconnect the disconnected trunk cable, electrode or leadwire. Change the trunk cable, lead set and module.
- **License invalid**
 - Contact authorized service personnel to set up the monitor's right license again.
- **Loading from network**
 - Loading mode from network.
- **Loading failed**
 - Load mode from network failed.

- **Long measurement time**
 - NIBP: reduce patient's motion.
- **Low gas sample flow**
 - Check the patient status.
 - Change the sampling line or water trap.
- **Mark x**
 - A snapshot is created manually.
- **Memory ERROR**
 - Contact authorized service personnel.
- **Mode Data Reset**
 - Contact authorized service personnel.
- **Module power supply overload**
 - Check the patient status.
 - Contact authorized service personnel.
- **Multiple agents present**
 - Check if the anesthetic agents are more than one.
 - Check the patient status.
- **Network: x**
 - Network is connected.
- **Network down: xxx (xxx = network name)**
 - Try to re-establish the connection.
 - Contact authorized service personnel.
- **Network recording...**
 - Network recorder has been started. Please wait until the recording is finished.
- **NIBP call service error**
 - NIBP: Contact authorized service personnel.
- **NIBP manual**
 - Check the cuff and cuff hose.
- **NIBP cuff overpressure**
 - Check NIBP cuff hose and tubes.
 - Restart measurement.
- **NIBP cuff loose**
 - Check the cuff and cuff hose.
- **NIBP cuff occlusion**
 - Check the tubes and hose.
- **No battery backup**
 - Replace the batteries, see [“Replacing the batteries.”](#)
- **No Entropy sensor**
 - Check connection between Entropy sensor and cable.
- **No Transducer**
 - IBP: Connect the transducer or the cable.
- **No SpO2 probe**
 - Check connection between the SpO₂ sensor and module.
- **No SpO2 pulse**
 - Try other measuring sites.

- **No printer selected**
 - Select a printer, see the “[Printing and recording](#)” chapter.
- **Patient discharged**
 - Discharge patient.
- **Patient admitted**
 - Admit patient.
- **P1 over range/P2 over range**
 - Check the patient status.
- **P1 under range/P2 under range**
 - Check the patient status.
 - Check the cables.
 - Rezero the transducer.
 - Change the module.
 - If the problem persists, contact authorized service personnel.
- **Printer error**
 - Printer is not working properly. Check that the network printer is operational.
- **Printing...**
 - Printing on network printer has been started. Please wait until the printing is finished.
- **Printing ready**
 - Monitor has completed sending printing data to the printer. Please wait until the printing is finished.
- **Recorder: out of paper**
 - Add paper.
- **Recorder: cover open**
 - Close the recorder cover.
- **Recorder: input voltage high, Recorder: input voltage low**
 - Contact authorized service personnel.
- **Recorder: thermal array overheat**
 - Contact authorized service personnel.
- **Recorder module removed**
 - Reconnect the recorder module if you need a recorder.
- **Recorder: system error 29**
 - The message rarely appear when the record information too large, the current recording will stop also. Please press the **Recorder Start/Stop** key again.
- **Recorder: system error X**
 - Contact authorized service personnel.
- **Replace Battery A, Replace Battery B**
 - Replace the battery as soon as possible, see “[Replacing the batteries](#).”
- **Replace D-Fend**
 - Gases: Replace the water trap.
- **Restart needed**
 - The monitor should be restarted.
- **Saving to network**
 - Saving trend and information to Network
- **Sample line blocked**
 - Gases: Change the sampling line and water trap.

- **Select inflation limits**
 - NIBP: You are using a hose without an automatic identification. Select appropriate inflation limits.
NOTE: **AUTO** option is not available for these hoses.
- **Snapshot created**
 - A snapshot is created manually or on alarms.
- **Snapshot memory full. Oldest snapshot erased.**
 - The oldest snapshot lost.
- **SpO2 probe off**
 - Check connection between sensor and patient.
 - Replace the sensor.
- **SpO2 faulty probe**
 - Replace the sensor.
- **SpO2 module error**
 - Contact authorized service personnel.
- **Tachy**
 - Check the patient status.
- **Temp sensor error**
 - Contact authorized service personnel.
- **T1 temperature error/T2 temperature error**
 - Check the probe whether is set to 400.
 - Contact authorized service personnel.
- **V Fib**
 - Check the patient status.
- **V Tach**
 - Check the patient status.
- **Weak pulsation**
 - Check the patient status.
 - Check the NIBP cuff position and attachment.
 - Check that the cuff is not damaged.
 - Repeat the measurement and check the patient status.
- **Zero ICP separately**
 - In IBP menu to zero ICP labelled channel separately.
- **xxx high/low** (xxx = measurement parameter)
 - Check the patient status.
 - Adjust the alarm limits.
- **xxx measurement removed**
 - Acquisition module has been removed. Connect the module if you want to restart the measurement.
 - Check the patient status.

Abbreviations

/min	beats per minute, breaths per minute	BAEP	brainstem auditory evoked potential
°C	Celsius degree	Bal	balance gas
°F	Fahrenheit degree	bar	1 atmosphere
µg	microgram	Beta, BE	beta frequency band
A	alveolar	Bigem.	bigeminy
A	arm (describing location)	BIS	bispectral index
a	arterial	Blad	bladder temperature
a/AO ₂	arterio-alveolar PO ₂ ratio	Blood	blood temperature (C.O. measurement)
AA	anesthetic agent	Body	body temperature
AaDO ₂	alveolo-arterial oxygen difference	BP	blood pressure
AAMI	Association for the Advancement of Medical Instrumentation	Brady	bradycardia
ABG	arterial blood gases	BSA	body surface area
ABP	arterial pressure	BSR	burst suppression ratio
ADU	Anesthesia Delivery Unit	B-T-O-B	beat-to-beat
AEP	auditory evoked potential	BTPS	body temperature and pressure, saturated gas
AirW	airway temperature	c	calculated/derived value
Alpha, Al	alpha frequency band	C	chest
AM	Anesthesia Monitor	C(a-v)O ₂	arteriovenous oxygen content difference
Amp	amplitude	C.I.	cardiac index
Ant.	anterior	C.O.	cardiac output
APN	apnea	cal.	calibration
Arrh.	arrhythmia	Calc	calculated/derived value
Art	arterial pressure	Calcs	calculations
ASY	asystole	CAM	Compact Anesthesia Monitor
ATMP	atmospheric pressure	CaO ₂	arterial oxygen content
ATPD	atmospheric/ambient temperature and pressure, dry gas	Casc.	cascaded (ECG)
ATPS	ambient temperature and pressure, saturated gas	cc	cubic centimeter
aw	airway	CCCM	Compact Critical Care Monitor
AV	atrioventricular	CCM	Critical Care Monitor
aVF	left foot augmented lead	CCO	continuous cardiac output
Avg.	average	CcO ₂	capillary oxygen content
aVL	left arm augmented lead	CCU	cardiac (coronary) care unit
aVR	right arm augmented lead	CEL	Celsius degree
Axil	axillary temperature	CISPR	International Special Committee on Radio Interference
		CFI	Cardiac Function Index
		cmH ₂ O	centimeter of water

CMRR	common mode rejection ratio	EE	energy expenditure (kcal/24h)
CO	carbon monoxide	EEG	electroencephalogram
CO ₂	carbon dioxide	EEG1	first EEG waveform
COHb	carboxyhemoglobin	EEG2	second EEG waveform
Compl	compliance	EEG3	third EEG waveform
Cont.	continuous	EEG4	fourth EEG waveform
Contrl	controlled ventilation	EEMG	evoked electromyogram
Core	core temperature	EEtot	total energy expenditure
Count	count of responses	elect	electrode
CPB	cardiopulmonary bypass	elev.	elevation
CPP	cerebral perfusion pressure	EMC	electromagnetic compatibility
CSA	compressed spectral array	EMG	electromyogram
CT	computer tomography	Enf	enflurane
CvO ₂	(mixed) venous oxygen content	Entr	entropy
CVP	central venous pressure	EP	evoked potential
d	day	ESD	electrostatic discharge
dB	decibel	Eso	esophageal temperature
DBS	double burst stimulation (NMT)	ESV	end-systolic volume
DEL	delete	ESVI	end-systolic volume index
Delta, De	delta frequency band	ET, Et	end-tidal concentration
depr.	depression	EtAA	end-tidal anesthetic agent
Des	desflurane	EtBal	end-tidal balance gas
Dia	diastolic pressure	EtCO ₂	end-tidal carbon dioxide
Diagn	diagnostic (ECG filter)	EtN ₂ O	end-tidal nitrous oxide
DIFF	difference	EtO ₂	end-tidal oxygen
DIS	S/5 Device Interfacing Solution	ET-tube, ETT	endotracheal tube
DO ₂	oxygen delivery	EVLW	extravascular lung water
DO ₂ I	oxygen delivery index	EVLWI	extravascular lung water index
DSC	digital signal converter	exp	expiratory
Dyn.	dynamic	F	foot (describing location)
e	estimated	FAH	Fahrenheit degree
ECG	electrocardiogram	FEMG	frontal electromyogram
ECG1	first ECG waveform (top)	FFT	fast Fourier transform
ECG1/r	real-time ECG	Fi Fi	fraction of inspired gas
ECG2	second ECG waveform	FiAA	fraction of inspired anesthetic agent
ECG3	third ECG waveform	Fib	fibrillation
ED	emergency department	FiBal	fraction of inspired balance gas
EDV	end-diastolic volume	FiCO ₂	fraction of inspired carbon dioxide
EDVI	end-diastolic volume index	FiN ₂	fraction of inspired N ₂
		FiN ₂ O	fraction of inspired nitrous oxide

FiO2	fraction of inspired oxygen	Infl.	inflation (limit)
Flow	airway gas flow	insp	inspiratory
Freq.	frequent	Inv.	invasive
ft	foot, feet	InvBP	invasive blood pressure
FVloop	flow volume loop	Irreg.	irregular
G	Gauss	ISM	Industrial, Scientific and Medical
g	gram	ISO	International Standards Organisation
Graph.	graphical	Iso	isoflurane
GEDI	global enddiastolic volume index	ITBV	intrathoracic blood volume
GEDV	global enddiastolic volume	IVR	idioventricular rhythm
GEF	global ejection fraction	J	joule
H	hand (describing location)	K	kelvin
h	hour	kcal	kilocalorie
Hal	halothane	kJ	kilojoule
Hb	hemoglobin	kPa	kilopascal
Hbtot	total hemoglobin	L	left (describing location)
HCO3-	bicarbonate	L	leg (describing location)
Hemo Calcs	hemodynamic calculations	L, l	liter
Hemo	hemodynamic	l/min	liters/minute
HHb	reduced hemoglobin	Lab	laboratory
HME	heat and moisture exchanger	LAN	local area network
HMEF	heat and moisture exchanger with filter	LAP	left atrial pressure
hPa	hectopascal	Lat.	lateral
HR dif	heart rate difference	lb	pound
HR	heart rate	LCD	liquid crystal display
ht	height	LCW	left cardiac work
HW	hardware	LED	light emitting diode
Hz	hertz	LVEDP	left ventricular end diastolic pressure
I:E	inspiratory-expiratory ratio	LVEDV	left ventricular end diastolic volume
IABP	intra-aortic balloon pump	LVSW	left ventricular stroke work
IC	inspiratory capacity	LVSWI	left ventricular stroke work index
ICP	intracranial pressure	MAC	minimum alveolar concentration
ICU	intensive care unit	Max	maximum
ID	identification	mbar	millibar
IEC	International Electrotechnical Commission	mcg	microgram
Imped.	impedance; impedance respiration	mean	mean blood pressure
in	inch	mEq	milliequivalent
Inf.	inferior		

MetHb	methemoglobin	Oxy. Calcs	oxygenation calculations
MF	median frequency	P	partial pressure
mg	milligram	P	pressure
Min	minimum	P(BTPS)	pressure in BTPS conditions
min	minute	P(g-a)CO ₂	difference between gastrointestinal carbon dioxide and arterial blood carbon dioxide concentration
ml	milliliter		
MLAEP	middle-latency auditory evoked potential		
mmHg	millimeters of mercury		
mol	mole		
Monit	monitoring (ECG filter)	P(g-ET)CO ₂	difference between gastrointestinal carbon dioxide and end tidal carbon dioxide concentration
MRI	magnetic resonance imaging		
Mult.	multiple		
Multif. PVCs	multifocal PVCs	P(STPD)	pressure in STPD conditions
MV	minute volume	IBP1, IBP2	invasive pressure channel identification on module
MVexp	expired minute volume (l/min)		
MVexp(BTPS)	expired minute volume in BTPS conditions	PA	pulmonary arterial pressure
MVexp(STPD)	expired minute volume in STPD conditions	PA	pulmonary artery
MVinsp	inspired minute volume (l/min)	Pa	Pascal (unit of pressure)
MVspont	spontaneous minute volume	Paced	paced beats
Myo	myocardial temperature	PaCO ₂	partial pressure of carbon dioxide in the arteries
		PAO ₂	partial pressure of oxygen in the alveoli
N	neutral	PaO ₂	partial pressure of oxygen in the arteries
N ₂	nitrogen	PAOP	pulmonary artery occlusion pressure
N ₂ O	nitrous oxide	Paw	airway pressure
Na	sodium	Pbaro	barometric pressure
Naso	nasopharyngeal temperature	PCWP	pulmonary capillary wedge pressure
NEO	neonate	PE	polyethylene
Net	network	Pedi	pediatric
Ni-Cd	nickel-cadmium	PEEP	positive end-expiratory pressure
NIBP	non-invasive blood pressure	PEEPe	extrinsic positive end expiratory pressure
NiMH	nickel-metal hydride	PEEPe+i	total positive end expiratory pressure (ICU)
NMT	neuromuscular transmission	PEEPe+PEEPi	total positive end expiratory pressure (ICU)
NO	nitric oxide	PEEPi	intrinsic positive end expiratory pressure
NTPD	normal temperature and pressure, dry gas	PEEPtot	total positive end expiratory pressure (anesthesia)
Num.	numerical	PgCO ₂	gastrointestinal carbon dioxide concentration
O ₂	oxygen	pH	pH
O ₂ ER	oxygen extraction ratio	pHa	arterial pH
O ₂ Hb	oxygenated hemoglobin	pHi	intramucosal pH
OR	operation room	pHv	(mixed) venous pH
Oxy	oxygenation	PIC	patient interface cable

Pleth	plethysmographic pulse waveform	RR	respiration rate (total) (measured)
PM non-capt.	pacemaker non-capturing	rtm	rhythm
PM non-funct.	pacemaker non-functioning	RV	residual volume
PM	pacemaker	RVEDV	right ventricular end-diastolic volume
Pmax	maximum pressure	RVESV	right ventricular end-systolic volume
Pmean	mean pressure	RVP	right ventricular pressure
Pmin	minimum pressure	RVSW	right ventricular stroke work
Ppeak	peak pressure	RVSWI	right ventricular stroke work index
Pplat	plateau (pause) pressure		
PR	pulse rate	s	second
Prev	previous	SA	sinoatrial
psi	pounds per square per inch	SaO2	arterial oxygen saturation
pt	patient	S.A.R.	Specific Absorption Rate
PTC	post tetanic count (NMT)	SD	standard deviation
pts	patients	SE	state entropy
PVC	polyvinylchloride	SEF	spectral edge frequency
PVC	premature ventricular contraction	SEMG	spontaneous electromyogram
PVloop	pressure volume loop	Sev	sevoflurane
PvO2	partial pressure of oxygen in (mixed) venous blood	SI	stroke index
PVR	pulmonary vascular resistance	Skin	skin temperature
PVRI	pulmonary vascular resistance index	SN, S/N	serial number
Px	standard pressure label, x being 1, 2	Spiro	patient spirometry
QRS	QRS complex	SpO2	oxygen saturation
Qs/Qt	venous admixture	Spont	spontaneous breathing
		SQI	signal quality index
		SR	sinus rhythm
R	right (describing location)	SR	suppression ratio
RAP	right atrial pressure	SSEP	somatosensory evoked potentials
Raw	airway resistance	ST	single twitch (NMT)
RCW	right cardiac work	ST	ST segment of electrocardiograph
RCWI	right cardiac work index	STAT	continuous NIBP cuff inflation for five minutes
RE	response entropy	stat	static
Rect	rectal temperature	STBY	standby
REF	right ventricular ejection fraction	STfilt	ST filter (ECG)
ref.	reference	STPD	standard temperature and pressure, dry gas
Resp Rate	respiration rate (total) (measured)	Surf	surface temperature
Resp	respiration rate (total) (set)	SW	software
RF	radio frequency	SV	stroke volume
RMS	average (root mean square) power	SVC	supraventricular contraction
Room	room temperature	SVI	stroke volume index
RQ	respiratory quotient	SvO2	(mixed) venous oxygen saturation

SVR	systemic vascular resistance	V Fib	ventricular fibrillation
SVRI	systemic vascular resistance index	V Run	ventricular run
SVV	stroke volume variation	V Tachy	ventricular tachycardia
Sys	systolic pressure	v	venous
		V	ventricular
T	tesla	V	volume
T corr.	temperature correction	V/Q	ventilation/perfusion ratio
T inj.	injectate temperature	V0.5	volume expired during the first 0.5 seconds
T	temperature	V1.0	volume expired during the first second
t	time (min)	VA	alveolar ventilation
T(BTPS)	temperature in BTPS conditions	VC	vital capacity
T1%	first stimulus as % of the reference value (NMT)	VCO2	carbon dioxide production
T1, T2	temperature channel identification on module	Vd	dead space
Tab.	tabular	Vd/Vt	dead space ventilation
Tachy	tachycardia	Vent. Calcs	ventilation calculations
Tbl, Tblood	blood temperature	VO2	oxygen consumption
Temp	temperature	VO2calc	calculated oxygen consumption*
Theta, Th	theta frequency band	VO2I	oxygen consumption index
TOF	train of four (NMT)	VO2Icalc	calculated oxygen consumption index*
TOF%	ratio of the 4th to the 1st response (NMT)	Vol	volume
Trigem.	trigeminy		
TV	tidal volume	WLAN	wireless local area network
TVexp	expired tidal volume (ml)	wt	weight
TVinsp	inspired tidal volume (ml)		
Tx	temperature label, x being 1, 2 Tymptympanic	X	extreme
temperature		yr	year
		yrs	years

* with Fick equation

Technical specifications

WARNING: Operation of the monitor outside the specified values may cause inaccurate results.

NOTE: Information in this section may be especially useful to clinicians.

General specifications

Size	
B40 and B20 monitor	
Without extension module	312±5 mm (H) * 312±5 mm (W) * 158±5 mm (D)
With extension module	312±5 mm (H) * 352±5 mm (W) * 178±5 mm (D)
Weight	
B40 with extension module	≤7 kg
B20 with extension module	≤6 kg
Monitor Environment	
Operating temperature	Normal operation: 5 to 40°C (41 to 104°F) Charging batteries: 5 to 35°C (41 to 95°F)
Storage and transport temperature	-20 to 60°C (-4 to 140°F)
Operating humidity	20 to 90% noncondensing

Storage and transport humidity	10 to 90% noncondensing
Operating atmospheric pressure	700 to 1060 hPa (525 to 795 mmHg)
Storage and transport atmospheric pressure	700 to 1060 hPa (525 to 795 mmHg)
E-miniC module Environment	
Operating temperature	10 to 40°C (50 to 104°F)
Non-operating temperature	-25 to 70°C (-13 to 158°F)
Operating humidity	10 to 95% noncondensing
Non-operating humidity	10 to 95% noncondensing
Operating altitude	666 to 1060 mbar
E-sCAiO, E-sCO, N-CAiO modules Environment	
Operating temperature	10 to 40°C (50 to 104°F)
Non-operating temperature	-25 to 60°C (-13 to 140°F)
Operating humidity	10 to 98% noncondensing
Non-operating humidity	10 to 90% noncondensing

Operating altitude	660 to 1060 mbar
E-Entropy module Environment	
Operating temperature	10 to 40°C (50 to 104°F)
Non-operating temperature	-20 to 60°C (-4 to 140°F)
Operating humidity	10 to 90% noncondensing
Non-operating humidity	10 to 90% noncondensing
Electrical	
AC input voltage	100 to 240 V ±10%
AC input frequency	50/60 Hz
AC input power	≤150 VA
Power supply	Internal battery or AC power
Power cord type	cord connector IEC/EN 60320-1/C13
For USA, different type of plugs should be used for connection to the alternate voltage 13 A 125 V or 6 A 250 V.	
Fuse	250 V, 2.5 Ah
Battery	Exchangeable lithium-ion, 2 pcs max.
Battery life	300 cycles minimum to 50% capacity
Battery information	model SM 201-6; 11.1 V, 3.52 Ah
Charging time	2 hours to 90% per battery pack
Operation time	Up to 4.5 hours
Recorder	

Power consumption	Standby: ≤1.2 W Printing: ≤10 W
Recorder type	Thermal array
Resolution	Vertical 8 dots/mm (200 dots/inch) in non-waveform mode Horizontal 24 dots/mm (600 dots/inch) minimum in waveform mode
Paper width	50 mm, printing width 48 mm
Waveforms	Selectable 1, 2, or 3 waveforms
Print speed	1, 6.25, 12.5, 25 mm/s

Defibrillator synchronization connector

NOTE: In the defibrillator synchronization connector, Pin 1,2,3,4,7 are grounding.

Synchronization pulse (Pin 5)	
Pulse width:	10 ms ±20% positive pulse
Delay:	< 35 ms (R-wave peak to leading edge of pulse)
Amplitude:	CMOS compatible 3.5 V min. at 1 mA sourcing 0.5 V max. at 5 mA sinking
Output impedance:	200 Ω

ECG specifications

Leads available	3-lead configuration: I, II, III 5-lead configuration: I, II, III, aVR, aVL, aVF and VA
QRS detection range	0.5 to 5mV
QRS detection width (Q to S)	40 to 120 ms
Defibrillation protection	5000 V, 360 J
Recovery time	<5 s
Input impedance	Common mode > 10 M Ω @ 50/60 Hz Differential > 2.5 M Ω from 0.67 to 40 Hz
Common mode rejection	90 dB minimum at 50 Hz
Tall T wave rejection	>1.4 mV
ECG leads off detection	Active patient electrode: <30 nA Reference electrode: <300 nA
Filter modes	
50/60 Hz	
Monitoring filter	0.5 to 40 Hz
ST filter	0.05 to 40 Hz
Dagnostic filter	0.05 to 150 Hz
Heart rate	
Measurement range	30 to 300 bpm

Measurement accuracy	$\pm 5\%$ or ± 5 bpm, whichever is greater
resolution	1 bpm
Heart rate response time (IEC 60601-2-27 201.7.9.2.9.101 b) 5)	
Step increase from 80 to 120 bpm	average 6.9 s (6.5 to 7.5 s)
Step decrease from 80 to 40 bpm	average 8.2 s (7.6 to 10.0 s)
The heart rate calculation operates with irregular rhythms of IEC 60601-2-27 201.7.9.2.9.101 b) 4), the heart rate after a 20 second stabilization period is:	
Figure 3a	80 bpm
Figure 3b	59 bpm
Figure 3c	122 bpm
Figure 3d	117 bpm
Heart rate averaging computation (IEC 60601-2-27 201.7.9.2.9.101 b) 3)): Average of 10 second median values	
The average time and time range () to alarm (V Fib or V Tach) for tachycardia waveform are as follows (IEC 60601-2-27 201.7.9.2.9.101 b) 6))	
Figure 4a halved amplitude:	9.9 s (8.4 to 11.5 s)
Figure 4a normal amplitude:	7.1 s (5.8 to 8.2 s)
Figure 4a doubled amplitude:	4.4 s (4.2 to 4.6 s)

Figure 4b halved amplitude:	7.0 s (6.1 to 7.5 s)
Figure 4b normal amplitude:	5.8 s (4.5 to 7.4 s)
Figure 4b doubled amplitude:	6.1 s (5.1 to 7.0 s)
ST	
ST numeric range	-9 to 9 mm (-0.9 to 0.9 mV)
ST numeric accuracy	±0.2 mm or ±10%, whichever is greater (within the range of -8 to 8 mm)
ST numeric resolution	0.1 mm
Pacemaker detection	
Input voltage range	2 to 700 mV
Input pulse width	0.5 to 2 ms
Input overshoot	Specified for both Method A and Method B required in IEC 60601-2-27 201.12.1.101.13
Overshoot time	< 10 ms
Pacer pulse rejection of fast ECG signals	2.0 V/s (according to the test defined in IEC 60601-2-27 201.12.1.101.12)

NOTE: Pacemaker detector may not operate correctly during the use of high-frequency (HF) surgical equipment. The disturbances of HF surgical equipment typically cause false positive pacer detection.

Direct cardiac application:

The display area reserved for the ECG measurement in the monitoring system screen may not be adequate for displaying the complete ECG amplitude when measuring ECG direct from the surface of the heart. Clipping of the signal can be reduced by adjusting the size of the signal on the screen (for example, from the default 1.0 to 0.2) in the **ECG** menu.

Impedance respiration specifications

Measurement range	4 to 120 resp/min
Measurement accuracy	±5% or ±5 resp/min, whichever is greater
Normalized respiration sensing current	≤5.0 μA
Impedance respiration carrier frequency	31.25 kHz

GE TruSignal SpO₂ specifications

Measurement and display range	1 to 100%
Display resolution	1 digit (1% of SpO ₂)
Display averaging	Normal 12s, Fast 3s
Calibrated against functional oxygen saturation.	
Measurement accuracy	
Adult/Pediatric (100 to 70%):	without motion: ±2 digits (±3 digits with ear sensor)
	with motion: ±3 digits
	low perfusion: ±3 digits
Neonatal (100 to 70%):	without motion: ±3 digits with motion: ±3 digits
Adult/Pediatric/ Neonatal (69 to 1%):	unspecified
Wavelength of SpO ₂ probe LEDs:	Infrared LED 940 nm RedLED 660 nm
Maximum energy of SpO ₂ probe LEDs:	Infrared LED 42 µJ/pulse Red LED 62 µJ/pulse
NOTE: This information may be useful to clinicians, such as those performing photodynamic therapy.	
Pulse rate	
Measurement range	30 to 250 bpm
Display resolution	1 bpm

Measurement accuracy	
Without motion:	±2 bpm (Adult/Pediatric/Neonatal)
With motion:	±3 bpm (Adult/Pediatric/Neonatal)
Low Perfusion:	±5 bpm (Adult/Pediatric)

Table 1: Accuracy for sensors (Arms) *

GE SpO₂ Sensor	Non motion (70-100%)	Motion (70-100%)	Low perfusion (70-100%)**	Neonatal (70-100%)
TS-E-D, TS-E2-GE, TS-E4-GE	±3 digits	unspecified	unspecified	unspecified
TS-SE-3	±2 digits	unspecified	unspecified	±3 digits
TS-F-D, TS-F2-GE, TS-F4-GE, TS-SA-D, TS-SA4-GE	±2 digits	unspecified	±3 digits	unspecified
TS-W-D	±2 digits	unspecified	unspecified	unspecified
TS-AP-10, TS-AP-25	±2 digits	±3 digits	unspecified	unspecified
TS-AF-10, TS-AF-25	±2 digits	±3 digits	unspecified	±3 digits

* Because SpO₂ measurements are statistically distributed, only about 2/3 of the measurements can be expected to fall within ±1 Arms of the value measured by a CO-oximeter

Test methods used to establish SpO₂ accuracy: GE TruSignal SpO₂ measurement have been validated for no motion and motion accuracy in a controlled hypoxia studies with healthy non-smoking adult volunteers over the specified SpO₂ range. SpO₂ readings were compared to SaO₂ values of drawn blood samples measured by CO-oximetry. Subjects comprised both adult men and women and spanned a range of skin pigmentation.

** GE TruSignal technology have been validated for low perfusion SpO₂ accuracy over the specified range in a bench top testing against BioTek Index 2 patient simulator with 0.3% signal amplitude.

Table 2: The table below shows Arms values measured using GE SpO₂ sensors with GE CARESCAPE™ V100 in a clinical study.*

GE SpO₂ Sensor	70 - 80%	80 - 90%	90 - 100%
OXY-E	2.3 digits	1.4 digits	1.3 digits
OXY-SE	2.5 digits	2.0 digits	1.1 digits
OXY-F	1.3 digits	1.0 digits	1.1 digits
OXY-W	2.9 digits	1.8 digits	1.0 digits
OXY-AP	2.0 digits	1.9 digits	1.7 digits
OXY-AF	2.5 digits	1.4 digits	0.9 digits

* The sensors were clinically tested for accuracy with the following sensors: OXY-E (equivalent to TS-E-D, TS-E2-GE, TS-E4-GE), OXY-SE (equivalent to TS-SE-3), OXY-F (equivalent to TS-F-D, TS-F2-GE, TS-F4-GE, TS-SA-D, TS-SA4-GE), OXY-W (equivalent to TS-W-D), OXY-AP (equivalent to TS-AP-10, TS-AP-25), OXY-AF (equivalent to TS-AF-10, TS-AF-25).
The sensors were clinically tested for neonatal accuracy with the following sensors: OXY-SE (equivalent to TS-SE-3), OXY-AF (equivalent to TS-AF-10, TS-AF-25).

For supplemental data analysis presented in a format of Bland-Altman in User's Reference Manual 2081504-001, please check the accompanying document or CD.

Nellcor SpO₂ specifications

Measurement range	1 to 100%
Display range	0 to 100%
Calibrated against functional oxygen saturation.	
Measurement accuracy	Adult 100 to 70% ±2 digits Neo 100 to 70% ±3 digits Low perfusion 100 to 70% ±2 digits
Display resolution	1% of SpO ₂
Display averaging	2 to 7 seconds
Pulse rate	
Measurement and display range	20 to 250 bpm
Display resolution	1 bpm
Measurement accuracy	±3 digits
Sensor Light Source*	
Wavelength	Infrared: 900 nm Red: 660 nm
Total optical output power of the sensor LEDs	less than 15 mW
* This information may be useful to clinicians, such as those performing photodynamic therapy.	

Masimo SpO₂ specifications

Measurement range	1 to 100%
Display range	0 to 100%
Calibrated against functional oxygen saturation.	
Measurement accuracy	
Without motion	Adult/Pediatric 100 to 70% ±2 digits Neonate 100 to 70% ±3 digits
With motion	Adult/Ped/Neo 100 to 70% ±3 digits
Low perfusion	100 to 70% ±2 digits
	0~69% unspecified
Display resolution	1% of SpO ₂
Display averaging	2 to 16 seconds
Pulse rate	
Measurement and display range	25 to 240 bpm
Display resolution	1 bpm
Measurement accuracy	Without motion ±3 bpm With motion ±5 bpm
Sensor Light Source*	
Wavelength	Infrared: 905 nm (nominal) Red: 660 nm (nominal)
Power Dissipation	Infrared: 22.5 mW (max) Red: 27.5 mW (max)

* This information may be useful to clinicians, such as those performing photodynamic therapy.

Invasive blood pressure

Measurement range	-40 to 320 mmHg (-5.3 to 42.7 kPa)
Measurement accuracy	±5% or ±2 mmHg, whichever is greater
Frequency response	4 to 22 Hz
Transducer sensitivity	5 µV/V/mmHg
Pulse rate	
Range	30 to 250 bpm
Accuracy	±5% or ±5 bpm, whichever is greater
Display resolution	1 bpm
Zero adjustment range	± 150 mmHg

NIBP

Measurement technique	Oscillometric with step deflation
Supported modes	Manual, automatic and stat
Measurement time	Adult/Pediatric inflate duration time less than 120 s Neonate cycle time less than 85 s
Measurement ranges	
Systolic	Adult/Pediatric: 30 to 290 mmHg Neonate: 30 to 140 mmHg
MAP	Adult/Pediatric: 20 to 260 mmHg Neonate: 20 to 125 mmHg
Diastolic	Adult/Pediatric: 10 to 220 mmHg Neonate: 10 to 110 mmHg
Accuracy	According to AAMI SP10-2002 4.4.5.2 B, accuracy of NIBP parameter was validated against the intra-arterial method ¹ .
Default initial inflation pressure	Adult/Pediatric: 135 ± 15 mmHg Neonate: 100 ± 15 mmHg
Over pressure allowed by independent safety controller	Adult/Pediatric: 300 ± 6 to 330 mmHg Neonate: 150 ± 3 to 165 mmHg
1. Blood pressure measurements determined with this device are equivalent to those obtained by an intra-arterial blood pressure measurement device, within the limits prescribed by the American National Standard, Manual, electronic, or automated sphygmomanometers	

Temperature

Measurement units	° Fahrenheit (F) ° Celsius (C)
Measurement range	10 to 45°C (50 to 113°F)
Measurement accuracy	± 0.1°C without temperature sensor
Display resolution	± 0.1°C at 25 to 45 °C with reusable probes
Probe types supported	Use only GE Healthcare recommend temperature YSI probes.
Temperature self-check	At start-up and then every 10 minutes
Probe type time response	
Reusable skin temperature probe:	3 s
Reusable adult central temperature probe:	6 s
Reusable pediatric central temperature probe:	4 s
Disposable skin temperature probe:	3 to 6 s
Disposable central temperature probe, 12F:	5 to 8 s
Disposable central temperature probe, 9F:	5 to 8 s

Airway gases

Accuracy specifications apply in normal conditions after a 30 min warm-up period:	
Ambient temperature	18 to 28°C, within ±5°C of calibration
Ambient pressure	660 to 1060 hPa, ±67 hPa of calibration
Ambient humidity	20 to 80%, within ±20% RH of calibration
Sampling rate E-miniC module E-sCO, E-sCAiO, N-CAiO module	<ul style="list-style-type: none"> • 150±25 ml/min (sampling line 2 to 3 m, normal conditions) • 120±20 ml/min
Warm-up time E-miniC module E-sCO, E-sCAiO, N-CAiO module	<ul style="list-style-type: none"> • 1 minute for operation, 30 minutes for full specification • 1 minute for operation with CO₂, O₂ and N₂O, 5 minutes for operation of anesthetic agents, 20 minutes for full specification
Respiration rate	
Measurement range E-miniC module E-sCO, E-sCAiO, N-CAiO module	<ul style="list-style-type: none"> • 4 to 80 breaths/min • 4 to 100 breaths/min

Measurement accuracy E-miniC module	<ul style="list-style-type: none"> • 4 to 20 breaths/min: ± 1 breaths/min • 20 to 80 breaths/min: $\pm 5\%$
E-sCO ₂ , E-sCAiO, N-CAiO module	<ul style="list-style-type: none"> • 4 to 20 breaths/min: ± 1 breaths/min • 20 to 100 breaths/min: $\pm 5\%$
Resolution	1 breaths/min
CO₂	
CO ₂ measurement range E-miniC module	<ul style="list-style-type: none"> • 0 to 20 vol%
E-sCO ₂ , E-sCAiO, N-CAiO module	<ul style="list-style-type: none"> • 0 to 15 vol%
CO ₂ measurement accuracy E-miniC module	<ul style="list-style-type: none"> • 0 to 15 vol%: $\pm (0.2 \text{ vol}\% + 2\% \text{ of reading})$ • 15 to 20 vol%: $\pm (0.7 \text{ vol}\% + 2\% \text{ of reading})$ <p>NOTE: Valid for respiration rate < 40 breaths/min at I:E ratio of 1:1. (Relative error is typically 10% for respiration rate 80 breaths/min at I:E ratio of 1:1.) The accuracy is specified in simulated ventilation. With higher respiration rates and with varying ventilation methods the specifications may not be met.</p>
E-sCO ₂ , E-sCAiO, N-CAiO module	<ul style="list-style-type: none"> • $\pm (0.2 \text{ vol}\% + 2\% \text{ of reading})$

CO ₂ display resolution	0.1%, 0.1kpa or 1 mmHg
CO ₂ total system response time E-miniC module	<ul style="list-style-type: none"> • < 2.4 seconds with a 3m sampling line
E-sCO ₂ , E-sCAiO, N-CAiO module	<ul style="list-style-type: none"> • < 3.3 seconds with a 2 or 3m sampling line
CO ₂ rise time E-miniC module	<ul style="list-style-type: none"> • < 300 ms with nominal flow
E-sCO ₂ , E-sCAiO, N-CAiO module	<ul style="list-style-type: none"> • < 260 ms with 120 ml/min sampling rate and 2 or 3m sample line
CO ₂ drift	< 0.1 vol%
O₂	
O ₂ measurement range	0 to 100 vol%
O ₂ measurement accuracy	$\pm (1 \text{ vol}\% + 2\% \text{ of reading})$
O ₂ display resolution	1% for values under -10% and over 10% 0.1 for values between -9.9...9.9%
O ₂ total system response time	< 3.3 seconds with a 2 or 3m sampling line
O ₂ rise time	< 260 ms
O ₂ drift	< 0.3 vol%
N₂O	

N ₂ O measurement range	0 to 100 vol%
N ₂ O measurement accuracy	0 to 85 vol%: ± (2 vol% + 2% of reading) 85 to 100 vol%: ± (2 vol% + 8 % of reading)
N ₂ O display resolution	1%
N ₂ O total system response time	< 3.4 seconds with a 2 or 3m sampling line
N ₂ O rise time	< 320 ms with 120 ml/min sampling rate and 2 or 3m sample line
N ₂ O drift	< 0.3 vol%
Anesthetic agents	
Anesthetic agents specified measurement range	Hal, Enf, Iso: 0 to 6 vol% Sev: 0 to 8 vol% Des: 0 to 20 vol%
Anesthetic agents measurement accuracy	± (0.15 vol% + 5% of reading)
Anesthetic agents display resolution	0.01% for values between 0...1% 0.1% for values equal or above 1%
Anesthetic agents total system response time	< 3.5 seconds with a 2 or 3m sampling line (< 3.8 for Hal)

Anesthetic agents rise time	Hal, Enf, Iso, Des: < 420 ms with a 3 m sampling line Hal: < 800 ms with a 3 m sampling line Hal, Enf, Iso, Des: < 700 ms with a 6 m sampling line Hal: < 1800 ms with a 6 m sampling line
Hal drift	< 0.1 vol%
Enf drift	< 0.1 vol%
Iso drift	< 0.1 vol%
Sev drift	< 0.1 vol%
Des drift	< 0.3 vol%
The E-sCAiO, N-CAiO modules automatically identify the anesthetic agent present in the sampled gas and measure the concentration of the identified agent.	
Identification threshold	0.15 vol%
Identification time	< 20 s
The E-sCAiO module automatically identifies mixtures of two anesthetic agents present in the sampled gas and measures the concentrations of the two identified agents.	
Identification threshold for the second agent at 1 MAC of the first agent:	0.2 vol% +10% of the concentration of the first agent
Effects of interfering gases and vapors	
E-miniC module	

<p>Non-disturbing gases of which effect on CO₂ (5 vol%) readings < 0.2 vol%:</p>	<ul style="list-style-type: none"> - Ethanol C₂H₅OH (<0.3%) - Acetone (<0.1%) - Methane CH₄ (<0.2%) - Nitrogen N₂ (0-100%) - water vapor (0-100%) - Trichloromonofluoromethane (<1%) - Dichlorotetrafluoroethane (<1%) - Dichlorofluoromethane (<1%)
--	---

<p>Disturbing gas and its effect</p>	<ul style="list-style-type: none"> • Halotane (4%): increases CO₂ (5 vol%) < 0.3 vol% • Isoflurane (5%): increases CO₂ (5 vol%) < 0.4 vol% • Enflurane (5%): increases CO₂ (5 vol%) < 0.4 vol% • Desflurane (24%): increases CO₂ (5 vol%) < 1.2 vol% • Sevoflurane (6%): increases CO₂ (5 vol%) < 0.4 vol% • N₂O (40%): increases CO₂ (5 vol%) < 0.4 vol% • Helium (50%): decreases CO₂ (5 vol%) < 0.3 vol% • If O₂ compensation is not activated: O₂ (40-95%) decreases < 0.3 vol% • If O₂ compensation is activated: O₂ (40-95%) error < 0.15 vol% • If N₂O compensation is not activated: N₂O (40-80%) increases < 0.8 vol% • If N₂O compensation is activated: N₂O (40-80%) error < 0.3 vol%
<p>E-sCO, E-sCAiO, N-CAiO module</p>	

Non-disturbing gases:	<ul style="list-style-type: none"> – Ethanol C₂H₅OH (< 0.036%) – Acetone (< 0.2%) – Methane CH₄ (< 0.3%) – Isopropanol (< 0.48%) – Nitrogen N₂ – Carbon Monoxide CO (< 100 ppm) – Nitrous Oxide NO (< 200 ppm) – Freon R134A (< 1%) (for CO₂, O₂ and N₂O) – Water vapor
Effects of a non-disturbing gas to the measured gas concentrations	<ul style="list-style-type: none"> • CO₂ < 0.2 vol% • N₂O < 2 vol% • O₂ < 2 vol% • Anesthetic agents < 0.15 vol%
Gas cross effects	<ul style="list-style-type: none"> • Helium (50 vol%): Decreases CO₂ (5 vol%) readings < 0.5 vol% Decreases O₂ (50 vol%) readings < 2 vol% • Xenon (80 vol%): Decreases CO₂ (5 vol%) readings < 0.5 vol% Decreases O₂ (14 vol%) readings < 1.5 vol%

NOTE: E-miniC measurement is intended for patients weighing over 5 kg (11 lb).

Entropy

Display range	<ul style="list-style-type: none"> • 0 to 100 • 0 to 91 • 0 to 100%
Response Entropy (RE) State Entropy (SE) Burst Suppression Ratio (BSR)	
Display accuracy	±1 or ±1%
Amplifier input impedance	1 MΩ @ 50 Hz
Defibrillation protection	3000 V, 130 J
Amplifier frequency range	0.5 to 118 Hz

Electromagnetic Compatibility

Changes or modifications to this system not expressly approved by GE can cause EMC issues with this or other equipment. This system is designed and tested to comply with applicable regulation regarding EMC and must be installed and put into service according to the EMC information stated in this section.

Guidance and manufacturer's declaration – electromagnetic emissions

Guidance and manufacturer's declaration – electromagnetic emissions		
The monitor is intended for use in the electromagnetic environment specified below. The customer or the user of the monitor should assure that it is used in such an environment.		
Emissions test	Compliance	Electromagnetic environment - guidance
RF emissions CISPR 11	Group 1	The monitor uses RF energy only for its internal function. Therefore, its RF emissions are very low and are not likely to cause any interference in nearby electronic equipment. The monitor is suitable for use in all establishments other than domestic establishments and those directly connected to the public low-voltage power supply network that supplies buildings used for domestic purposes.
RF emissions CISPR 11	Class A	
Hermonic emissions IEC 61000-3-2	Class A	
Voltage fluctuations/ flicker emissions IEC 61000-3-3	Complies	

Guidance and manufacturer's declaration – electromagnetic immunity

Guidance and manufacturer's declaration – electromagnetic immunity			
The monitor is intended for use in the electromagnetic environment specified below. The customer or the user of the monitor should assure that it is used in such an environment.			
Immunity test	IEC 60601 test level	Compliance level	Electromagnetic environment - guidance
Electrostatic discharge (ESD) IEC 61000-4-2	±6 kV contact ±8 kV air	±6 kV contact ±8 kV air	Floors should be wood, concrete or ceramic tile. If floors are covered with synthetic material, the relative humidity should be at least 30%.
Electrical fast transients/bursts IEC 61000-4-4	±2 kV for power supply lines	±2 kV for power supply lines	Mains power quality should be that of a typical commercial or hospital environment.
Surge IEC 61000-4-5	±1 kV differential mode ±2 kV common mode	±1 kV differential mode ±2 kV common mode	Mains power quality should be that of a typical commercial or hospital environment.

<p>Voltage dips, short interruptions and voltage variations on power supply lines IEC 61000-4-11</p>	<p><5% U_T (>95% dip in U_T) for 0.5 cycle</p> <p>40% U_T (60% dip in U_T) for 5 cycles</p> <p>70% U_T (30% dip in U_T) for 25 cycles</p> <p><5% U_T (>95% dip in U_T) for 5 sec</p>	<p><5% U_T (>95% dip in U_T) for 0.5 cycle</p> <p>40% U_T (60% dip in U_T) for 5 cycles</p> <p>70% U_T (30% dip in U_T) for 25 cycles</p> <p><5% U_T (>95% dip in U_T) for 5 sec</p>	<p>Mains power quality should be that of a typical commercial or hospital environment. If user of the equipment requires continued operation during power mains interruptions, it is recommended that the equipment be powered from an uninterruptible power supply or a battery.</p>
<p>Power frequency (50/60 Hz) magnetic field IEC 61000-4-8</p>	<p>3 A/m</p>	<p>3 A/m</p>	<p>Power frequency magnetic field should be at levels characteristic of a typical location in a typical commercial or hospital environment.</p>
<p>NOTE U_T is the a.c. mains voltage prior to application of the test level.</p>			

Guidance and manufacturer's declaration – electromagnetic immunity

Guidance and manufacturer's declaration – electromagnetic immunity			
The monitor is intended for use in the electromagnetic environment specified below. The customer or the user of the monitor should assure that it is used in such an environment.			
Immunity test	IEC 60601 test level	Compliance level	Electromagnetic environment - guidance
			<p>Portable and mobile RF communications equipment should be used no closer to any part of the equipment, including cables, than the recommended separation distance calculated from the equation applicable to the frequency of the transmitter.</p> <p>Recommended separation distance</p>
Conducted RF IEC 61000-4-6	3 Vrms 150 kHz to 80 MHz	3 Vrms	$d = \left[\frac{3.5}{V_1} \right] \sqrt{P}$
Radiated RF IEC 61000-4-3	3 V/m 80 MHz to 2.5 GHz	3 V/m	$d = \left[\frac{3.5}{E_1} \right] \sqrt{P}$ 80 MHz to 800 MHz $d = \left[\frac{7}{E_1} \right] \sqrt{P}$ 800 MHz to 2.5 GHz

			<p>where P is the maximum output power rating of the transmitter in watts (W) according to the transmitter manufacturer and d is the recommended separation distance in metres (m). Field strengths from fixed RF transmitters, as determined by an electromagnetic site survey, ^a should be less than the compliance level in each frequency range. ^b</p> <p>Interference may occur in the vicinity of equipment marked with the following symbol:</p> 
--	--	--	--

NOTE 1 At 80 MHz and 800 MHz, the higher frequency range applies.

NOTE 2 These guidelines may not apply in all situations. Electromagnetic propagation is affected by absorption and reflection from structures, objects and people.

^aField strengths from fixed transmitters, such as base stations for radio (cellular/cordless) telephones and land mobile radios, amateur radio, AM and FM radio broadcast and TV broadcast cannot be predicated theoretically with accuracy. To assess the electromagnetic environment due to fixed RF transmitters, an electromagnetic site survey should be considered. If the measured field strength in the location in which the equipment is used exceeds the applicable RF compliance level above, the equipment should be observed to verify normal operation. If abnormal performance is observed, additional measures may be necessary, such as reorienting or relocating the equipment.

^bOver the frequency range 150 kHz to 80 MHz, field strengths should be less than 3 V/m.

Recommended separation distances

The table below provides the recommended separation distances (in meters) between portable and mobile RF communications equipment and the monitor.

The monitor is intended for use in an electromagnetic environment in which radiated RF disturbances are controlled. The customer or the user of the equipment can help prevent electromagnetic interference by maintaining a minimum distance between portable and mobile RF communications equipment (transmitters) and the equipment as recommended below, according to the maximum output power of the communications equipment.			
Rated maximum output power of transmitter W	Separation distance according to frequency of transmitter m		
	150 kHz to 80 MHz $\left[\frac{3.5}{V1}\right]\sqrt{P}$	80 MHz to 800 MHz $\left[\frac{3.5}{E1}\right]\sqrt{P}$	800 MHz to 2.5 GHz $\left[\frac{7}{E1}\right]\sqrt{P}$
0.01	0.12	0.12	0.23
0.1	0.37	0.37	0.74
1	1.17	1.17	2.33
10	3.69	3.69	7.38
100	11.67	11.67	23.33
For transmitters rated at a maximum output power not listed above, the recommended separation distance d in meters (m) can be estimated using the equation applicable to the frequency of the transmitter, where P is the maximum output power rating of the transmitter in watts (W) according to the transmitter manufacture.			
NOTE 1At 80 MHz and 800 MHz, the separation distance for the higher frequency range applies.			
NOTE 2These guidelines may not apply in all situations. Electromagnetic propagation is affected by absorption and reflection from structures, objects and people.			



GE Medical Systems
Information Technologies, Inc.
8200 West Tower Avenue
Milwaukee, WI 53223 USA
Tel: + 1 414 355 5000
1 800 558 5120 (US only)
Fax: + 1 414 355 3790



GE Medical Systems
Information Technologies GmbH
Munzingerstrasse 5
79111 Freiburg
Germany
Tel: + 49 761 45 43 - 0
Fax: + 49 761 45 43 - 233

Asian Headquarters

GE Medical Systems
Information Technologies Asia
1 Huatuo Road
Zhangjiang Hi-tech Park Pudong
Shanghai, P.R. China, 201203
Tel: + 86 21 3877 7888
Fax: + 86 21 3877 7451

GE Medical Systems *Information Technologies*, a General Electric Company, going to market as
GE Healthcare.
www.gehealthcare.com

