

# C441 Ethernet module user manual (C441R, C441T, C441U, C441V)



**C441R & C441T**



**C441U & C441V**



*Powering Business Worldwide*

## Contents

Description	Page
1 Introduction . . . . .	3
2 Ratings. . . . .	3
3 Mounting and Dimensions . . . . .	4
3.1 C441R and C441T . . . . .	4
3.2 C441U and C441V . . . . .	6
4 Connections and switch settings. . . . .	7
4.1 Connecting To an Ethernet Network . . . . .	8
4.2 Setting the IP Address Mode. . . . .	10
4.3 Connecting To The Modbus Serial Port . . . . .	10
4.4 Connecting the I/O points and power supply . . . . .	11
4.5 S811+ to C441U and C441V . . . . .	14
4.6 Status Indicators . . . . .	14
4.7 Configuration Reset Button . . . . .	15
5 Configuration . . . . .	16
5.1 Configuration using a web browser. . . . .	16
5.2 Configuration using an EDS file. . . . .	16
6 EtherNet/IP Protocol Support . . . . .	16
6.1 Supported Connections . . . . .	16
6.2 EtherNet/IP Object Model for C441 Motor Insight . . . . .	16
6.3 EtherNet/IP Object Model for C440 overload relay . . . . .	24
6.4 EtherNet/IP Object Model for S611 Soft Starter . . . . .	28
6.5 EtherNet/IP Object Model for S811+ Soft Starter . . . . .	35
6.6 EtherNet/IP Object Model Stand Alone I/O. . . . .	48
7 Modbus TCP and Modbus Serial Protocol Support. . . . .	50
7.1 Supported Function Codes . . . . .	50
7.2 Register Definitions for the C441 Motor Insight . . . . .	50
7.3 Register Definition for the C440 Overload Relay . . . . .	54
7.4 Register Definition for the S611 Soft Starter . . . . .	56
7.5 Register Definitions for S811+ Soft Starter . . . . .	59
7.6 Register Definitions for use as stand alone I/O . . . . .	65

## 1 Introduction

The C441 Ethernet module enables Ethernet communications for the following Eaton Devices:

- C441 Motor Insight® overload and monitoring relay
- C440 Overload and monitoring relay
- S611 Soft Starter
- S811+ Soft Starter

The device can also be used stand alone as an Ethernet I/O block.

The table below describes the products covered in this manual and their primary usage

**Table 1. Product Selection**

Catalog #	Description	Use With
C441R	Plug In Ethernet Module with 120 Vac Inputs and Relay Outputs	C441 Motor Insight S611 Soft Starter
C441T	Plug In Ethernet Module with 24 Vdc Inputs and Relay Outputs	C441 Motor Insight S611 Soft Starter
C441U	Stand alone Ethernet Module with 120 Vac Inputs and Relay Outputs	C440 Overload As I/O Block S811+ Soft Starter
C441V	Stand alone Ethernet Module with 24 Vdc Inputs and Relay Outputs	C440 Overload As I/O Block S811+ Soft Starter

The Ethernet module provides the following key features:

- Supports EtherNet/IP protocol
- Supports Modbus TCP protocol
- Integrated web page for device monitoring and set up
- Dual Ethernet ports with integrated switch
- 4 Discrete Input Points and 2 Output relays
- Additional Modbus Serial monitoring port available for most configurations

The Ethernet Module can simultaneously support data access from EtherNet/IP originators and Modbus TCP clients.

## 2 Ratings

The following ratings apply to the C441R, C441T, C441U and C441V

**Table 2. Ethernet Physical Layer Ratings**

Description	Rating
Media	Wire
Ethernet Link Speed	10/100 MB
Auto MDIX support	yes
# of Ports	2

**Table 3. Environmental Ratings of the Module**

Description	Rating	
Transportation and Storage	Temperature	-40°C – 85°C
	Humidity	5 – 95% non condensing
Operating	Temperature	-20°C – 50°C (-40°F – 131°F)
	Humidity	5 – 95% non condensing
	Altitude	Above 2000 meters (6600 feet), consult factory
Shock IEC 60068-2-27		15G any direction for 11 milliseconds
Vibration IEC 60068-206		5 – 150 Hz, 5G, 0.7 mm maximum peak-to-peak
Pollution Degree		3

**Table 4. Approvals and Certifications**

Electrical/EMC	Rating
ESD Immunity (IEC61000-4-2)	+/- 8 kV Air, +/-4 kV contact
Radiated Immunity (IEC61000-4-3)	10 V/m 80 – 1000 MHz, 80% amplitude modulation @ 1 kHz
Fast Transient (IEC61000-4-4)	+/- 2 kV using direct method
Surge (IEC61000-4-5)	+/- 2 kV line-to-ground
RF Conducted (IEC61000-4-6)	10 V, 0.15 – 80 MHz
Ingress Protection Code	IP20
Radiated and Conducted Emissions	EN55011 Class A
Agency Certifications	UL® 508
	cUL® (CSA® C22.2 No. 14)
	CE (Low Voltage Directive)
	ODVA EtherNet/IP Certified

**Table 5. Input Power Supply Requirements**

Description	Requirement
Voltage Range	18 – 30 Vdc
Current Draw (Maximum)	50 mA

**Note:** Any UL Listed power supply with an isolated 24Vdc voltage output can be used provided that a UL listed or recognized fuse rated no more than 4A maximum is installed

### **⚠ WARNING**

ONLY APPLY 24VDC TO THE MOTOR INSIGHT COMMUNICATION MODULE POWER SUPPLY CONNECTOR. USE OF ANY OTHER VOLTAGE MAY RESULT IN PERSONAL INJURY, PROPERTY DAMAGE AND DAMAGE TO THE MODULE.

The C441R and C441U provide connection for four AC Input points the ratings for these inputs are:

**Table 6. AC Input Ratings**

Specification	Value
Number of Inputs	4
Nominal voltage	120 Vac
Nominal Current	15 mA
Operating Range	80 – 140 Vac
Operating Frequency	50/60 Hz
Signal Delay Max	30 ms
Input Type	IEC 61131-2, type 1 digital

The C441T and C441V provide connection for four DC Input points. The ratings for these inputs are:

**Table 7. DC Input Ratings**

Specification	Value
Number of Inputs	4
Nominal voltage	24 Vdc
Nominal Current	5 mA
Type	Current Sinking
Input Type	IEC 61131-2, type 1 digital

All units provide two output relays. The ratings of the relay outputs are:

**Table 8. Relay Output Ratings**

Specification	Value
Num Contacts	2 Independent Relays (1 Form C, 1 Form A)
Thermal Contact	5 A
Rated Insulation Voltage	300 Vac
Max Operating Voltage	120 Vac
Max Operation Current	5 A
Electrical Life	1□10 <sup>5</sup> Operations
Mechanical Life	1□10 <sup>6</sup> Operations

## 3 Mounting and Dimensions

### 3.1 C441R and C441T

The Ethernet module is designed to be installed on the right side of the Motor Insight base unit.

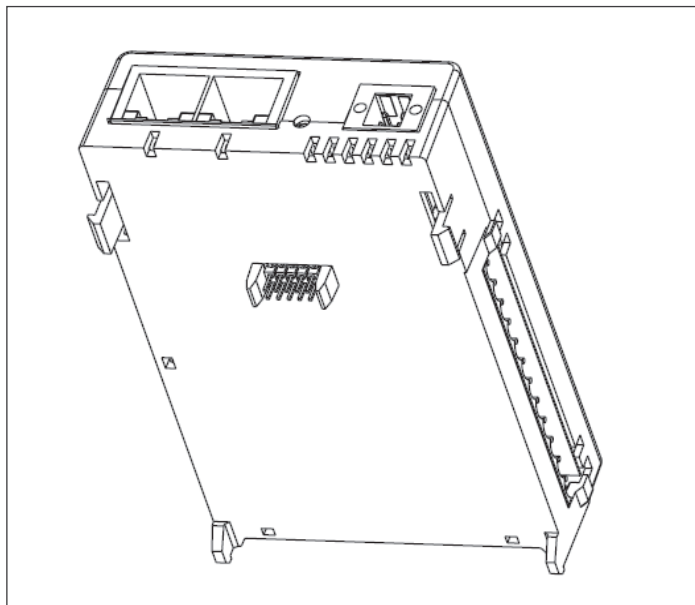
**Figure 1. Installation Diagram**

1. Align module with side of Motor Insight base unit
2. Slide module bottom pegs in appropriate slots
3. Rotate module up and gently click the base unit and module together.

The resulting dimensions of the Motor Insight base unit and Ethernet module is shown in Figure 2.

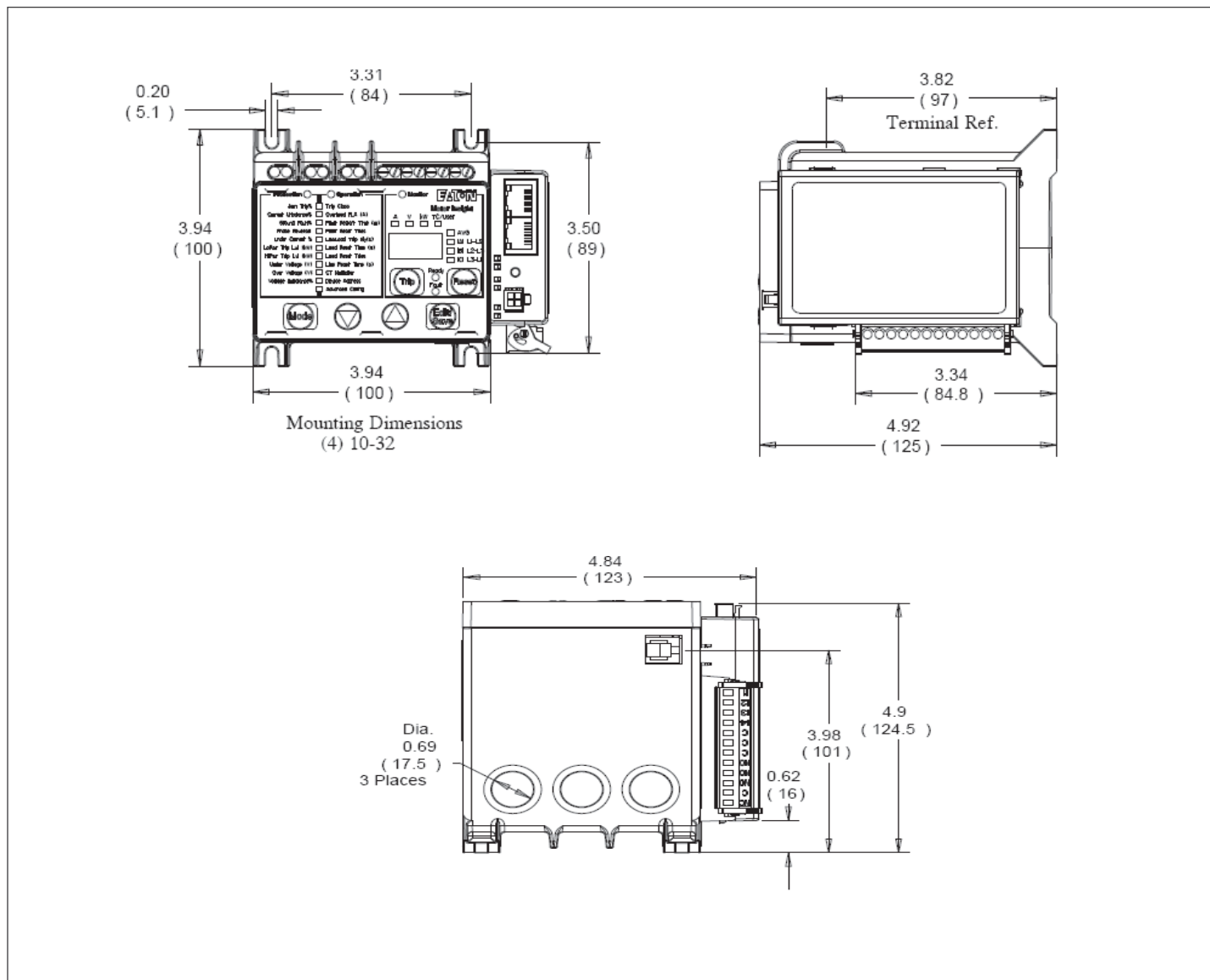

Figure 2. Product Dimensions (Attached to C441 Base Unit)

### 3.2 C441U and C441V

The C441U and C441V have both screw mounting feet and a din rail spring mounting feature.

To mount the adapter to a din rail place the bottom of the device on the rail first then apply gentle upward force while pushing the device flat against the din rail.

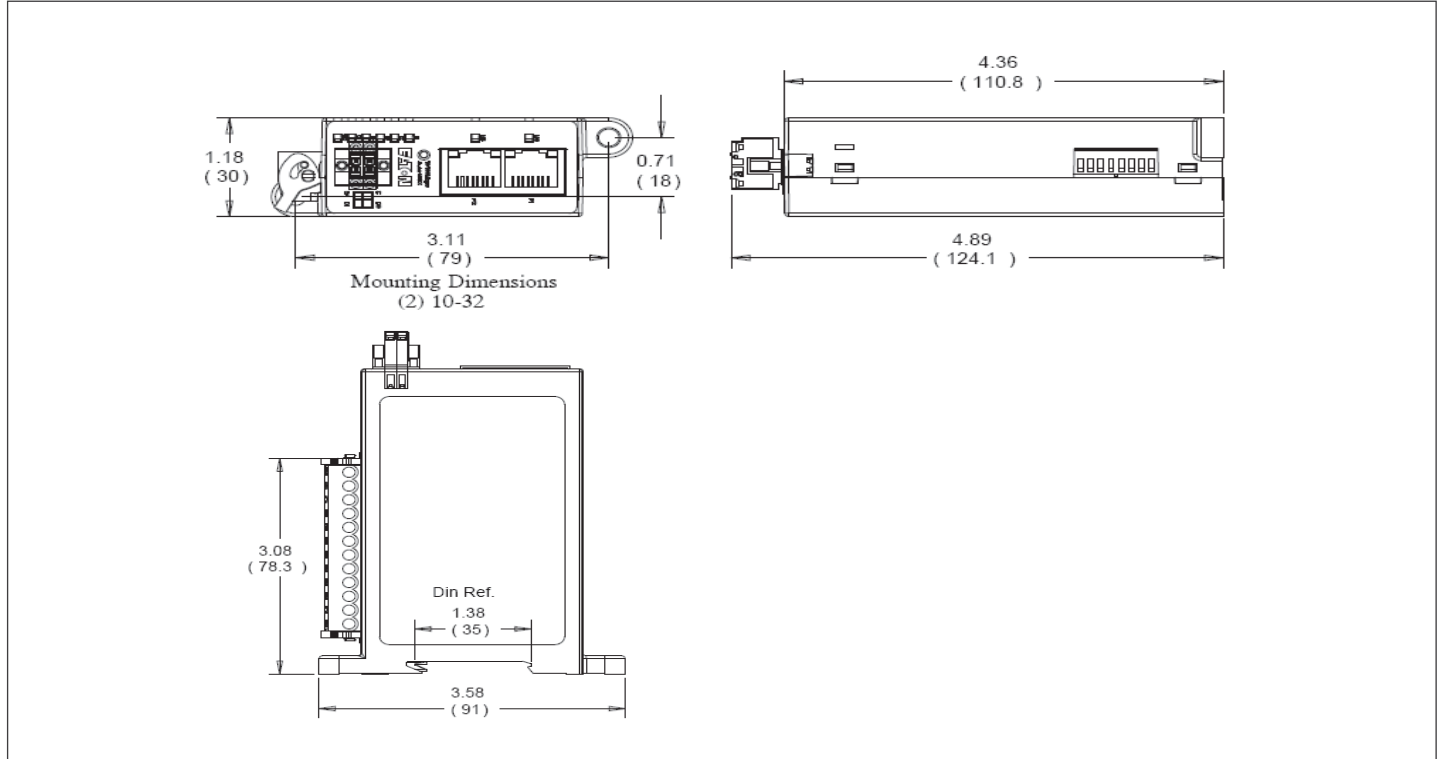

Figure 3. C441U and C441V Dimensions and Mounting

### 4 Connections and Switch Settings

This section describes the connections and switch settings for the Ethernet module. The figure below depicts the connection points, LED indicators and DIP switch settings that will be described in this section.

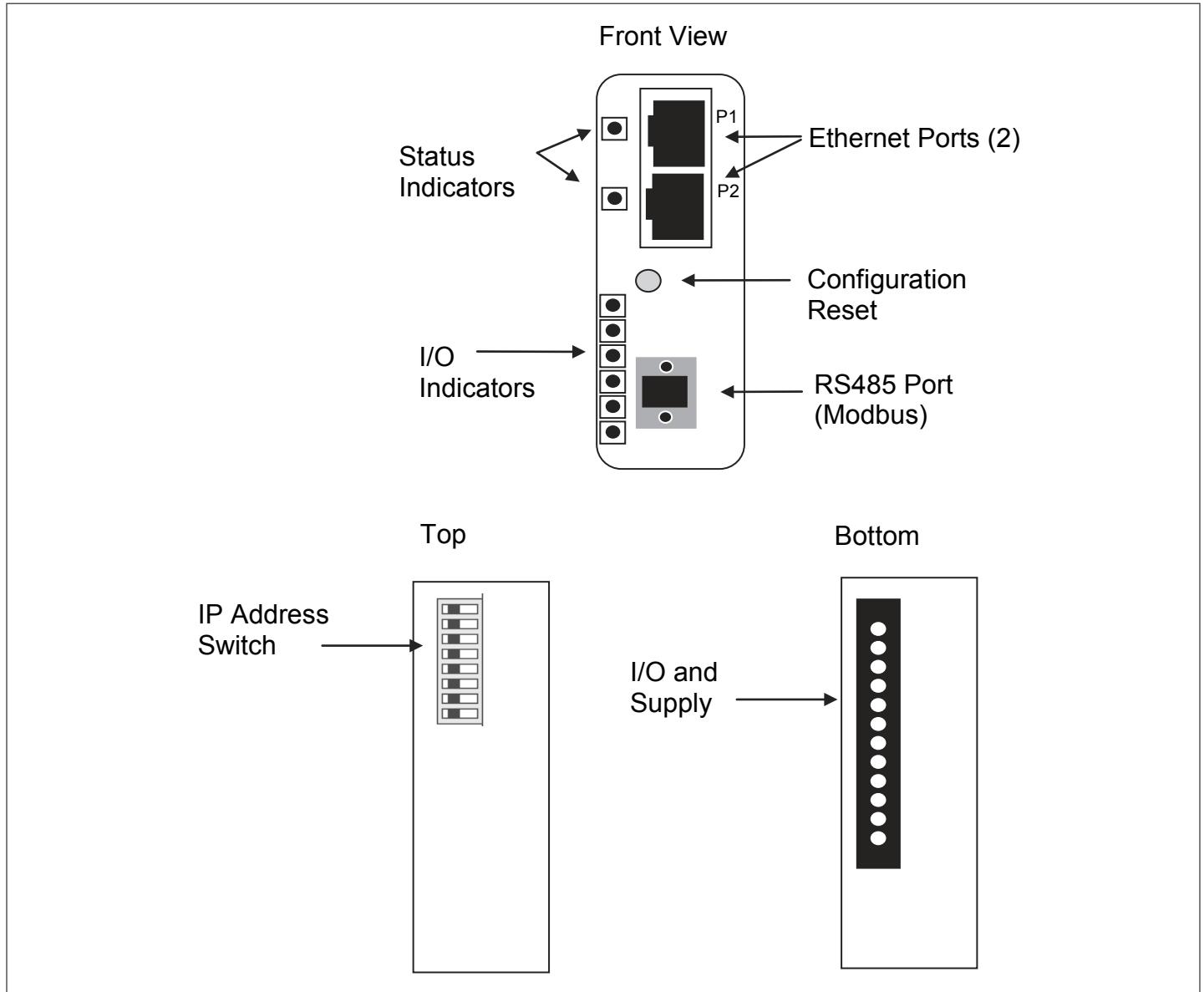

Figure 4. Module Connections, Settings, and Indicators

#### 4.1 Connecting to an Ethernet Network

The Ethernet module provides two Ethernet ports labeled P1 and P2. The two ports allow the module to be connected in either a star, linear or ring network. These options are described below.

##### Star Network Connection

In a star network connection one port of the Ethernet module is connected to a standard Ethernet switch. The figure below depicts 3 Motor Insight modules connected to a PLC over Ethernet using an external 4 port switch:

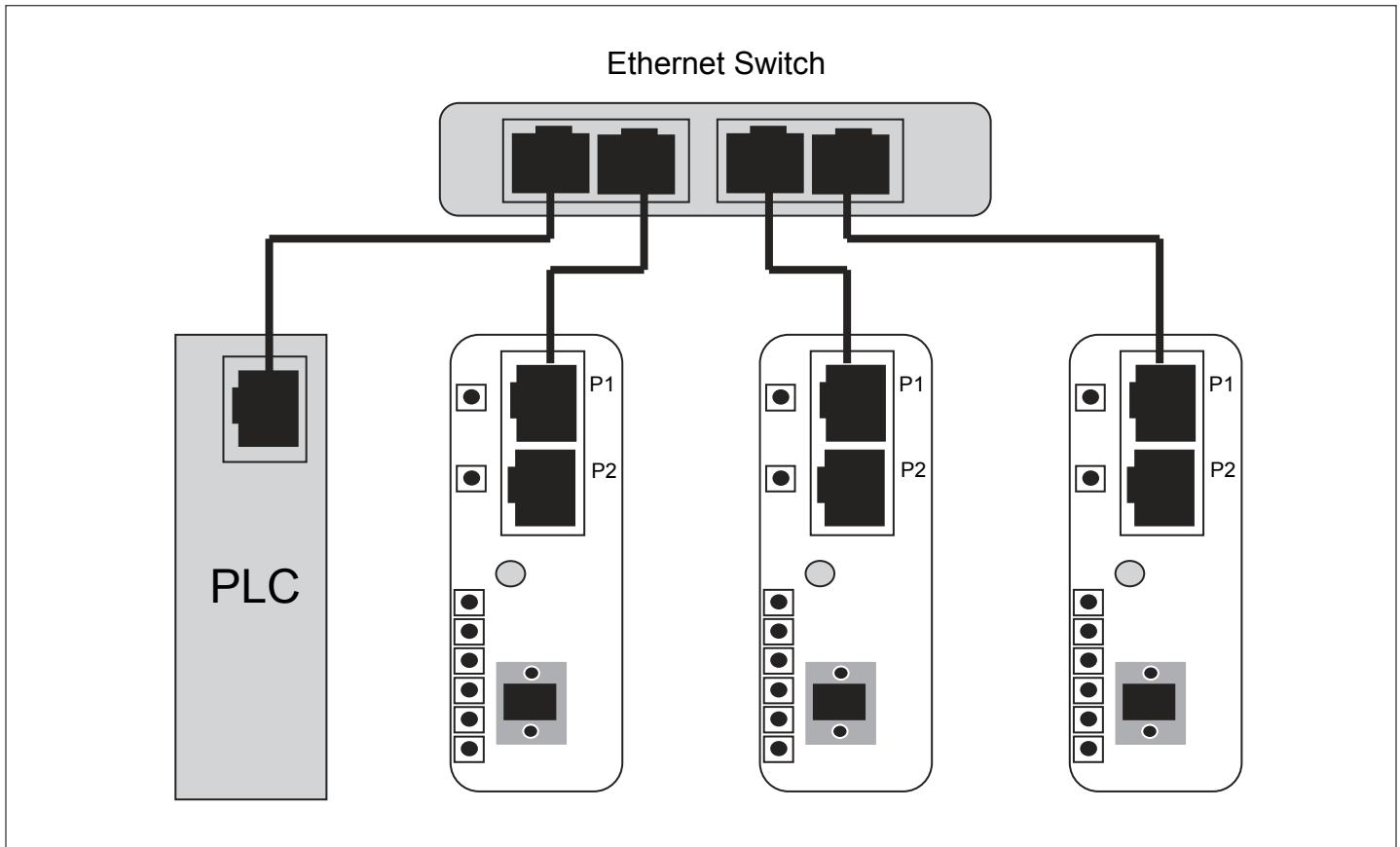

Figure 5. Star Network Connection Example

Either P1 or P2 can be used in a star network.



### Linear Network Connection

In a Linear network the number of external switch ports can be reduce, or the external switch can be eliminated all together. The figure below depicts three Motor Insight modules connected to a PLC without any external switch.

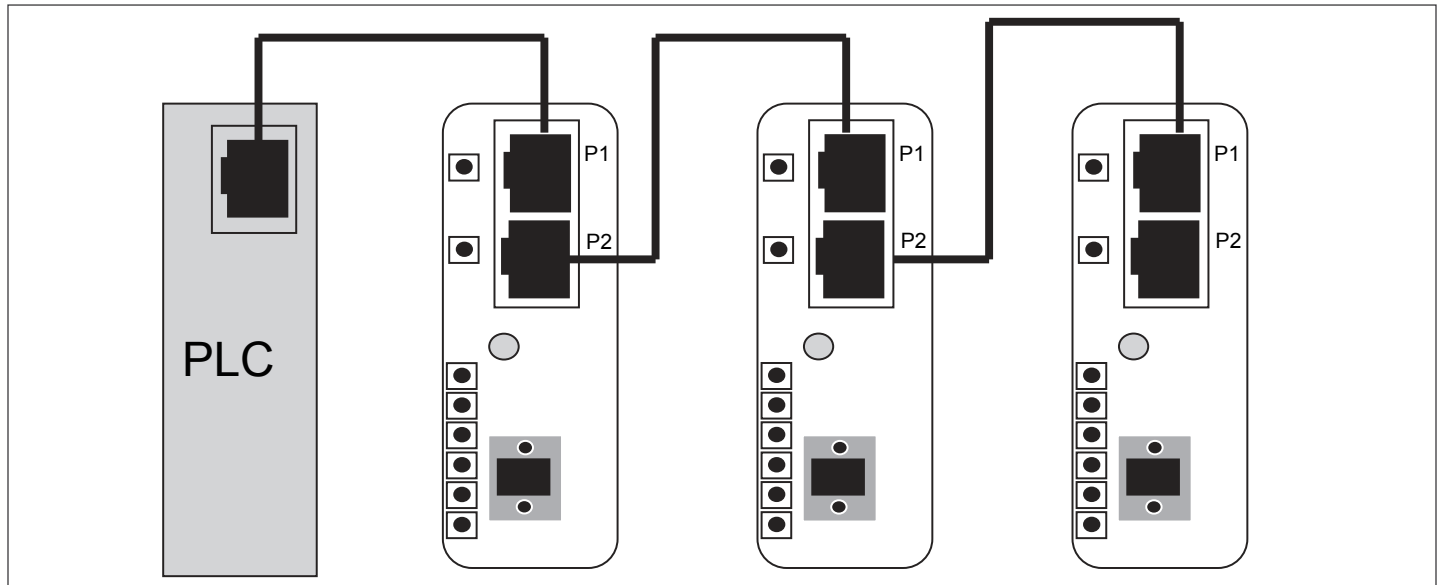

**Figure 6. Linear Network Connection Example**

It does not matter which port (P1 or P2) is used for each connection shown in the diagram.

### Ring Network Connection

Some PLC systems and external switches provide support for ring network topologies. In these systems a closed ring is formed and a special algorithm is used to allow communications to continue even if a cable becomes disconnected or one of the ring devices is removed.

Two common ring algorithms are:

- Rapid Spanning Tree Protocol (RSTP)
- Device Level Ring (DLR)

While the Motor Insight does NOT directly execute these algorithms, it has been designed to be included in these two types of rings. The figure below depicts three Motor Insight units connected in a ring with a PLC that supports a ring algorithm.

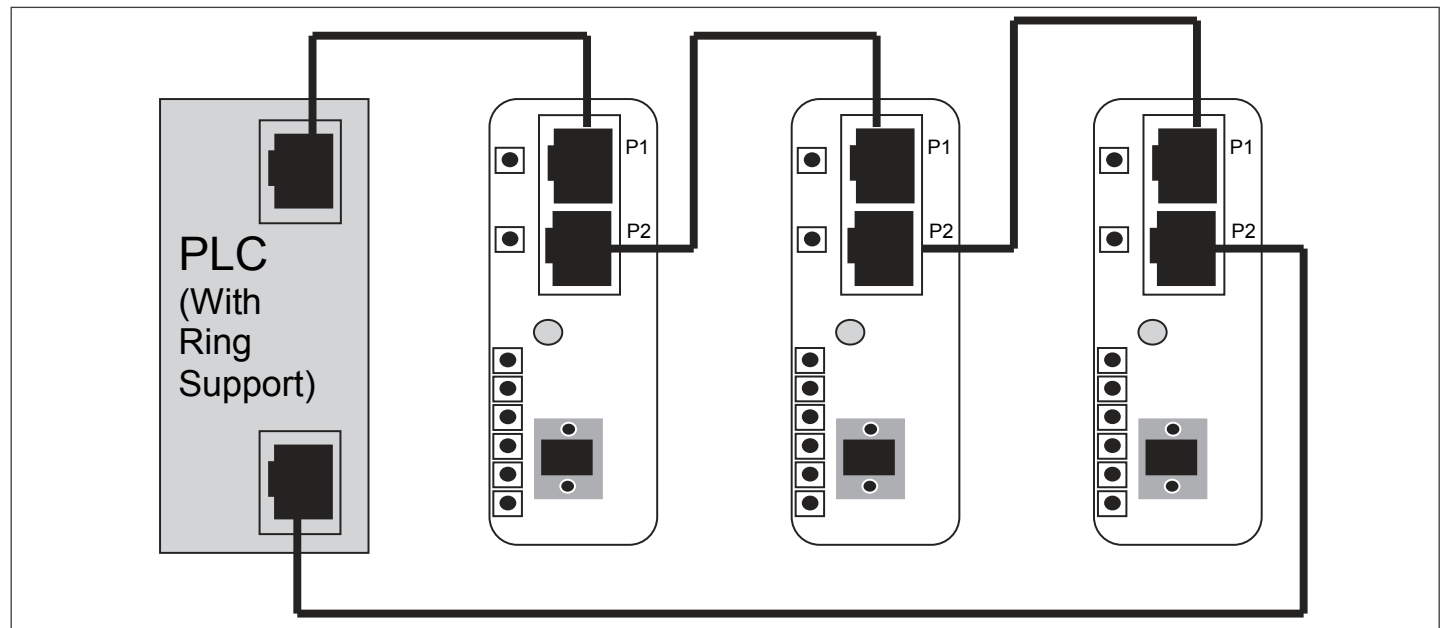

**Figure 7. Ring Network Connection Example**

It does not matter which port (P1 or P2) is used for each connection shown in the diagram.

## 4.2 Setting the IP Address Mode

Though the Ethernet Module has two Ethernet Ports, it only has one IP address that is used to target communications to the device. The dip switch accessible on the top of the module is used to establish the IP address Mode. The switch settings and the resulting behaviors are depicted in the table below.

**Table 9. IP Address Switch Settings**

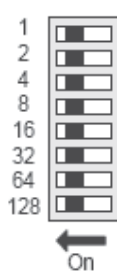
	Value	Mode	Behavior at reset (power cycle or configuration reset button)
	0	Restore	The operating IP configuration will be set to the follow values: IP Address = 192.168.1.254 Net Mask = 255.255.255.0 Gateway = 192.168.1.1 <b>Note:</b> This mode is intended for fast recovery from an unknown static IP configuration. The switch Value must be changed to apply a new IP setting
	1-253	Static (HW)	The Value determines the last byte of the IP address. The rest of the IP configuration will be equal to the Static NV values set via web pages or other protocol. <b>Note:</b> This mode is intended for applications where fast deployment of devices without web configuration is important.
	254	Static (NV)	The IP configuration will be set to the values stored in NV memory. The default NV values from the factory are: IP Address = 192.168.1.254 Net Mask = 255.255.255.0 Gateway = 192.168.1.1 These can be changed from the web page or by writes to modbus registers.
	255	DHCP	The IP configuration is set by an external DHCP server on the network.

## 4.3 Connecting to the Modbus Serial Port

The serial port on the Ethernet module supports a Modbus RTU or ASCII protocol as a slave device (default = RTU). The physical layer settings for the device have the following default values, and can be modified through the web page or writing to Modbus registers. A 4-pin connector is provided to connect the device to the Modbus network as shown in the figure below. Two of the pins provide an additional connection point for the 24 Vdc power supply.

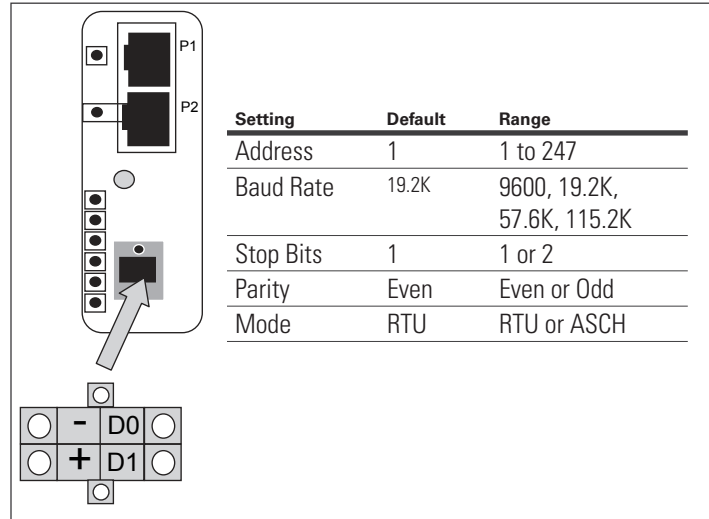

**Figure 8. Serial Modbus Connection**

**Note:** When the C441U or C441V are used with the C440 overload relay, this serial port is used to connect to the C440 serial port and is NOT available as a serial monitoring port.

4.4 Connecting the I/O Points and Power Supply

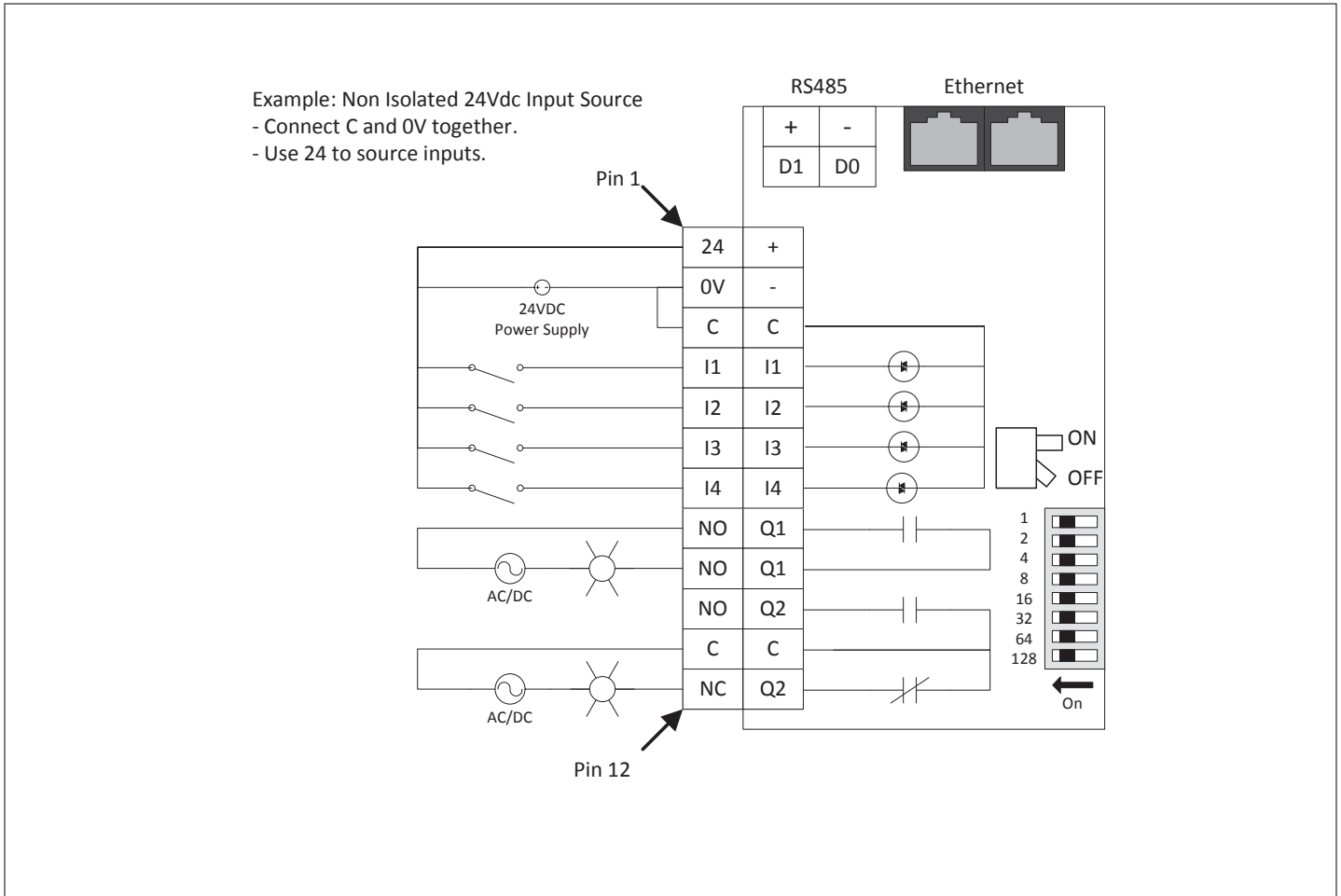

Figure 9. Wiring for C441T and C441V with Isolated DC Inputs

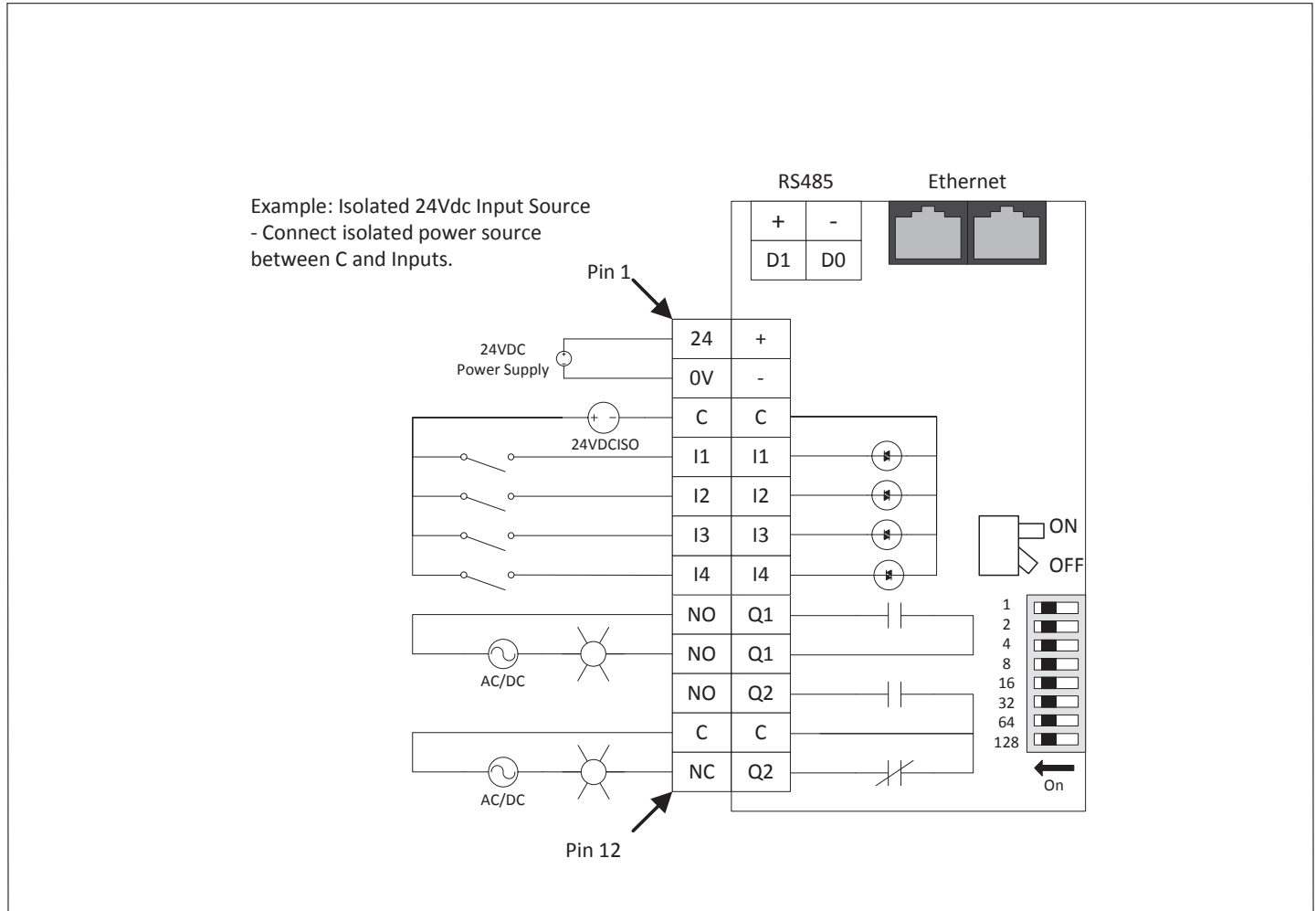

Figure 10. Wiring for C441T and C441V, Non-Isolated Inputs

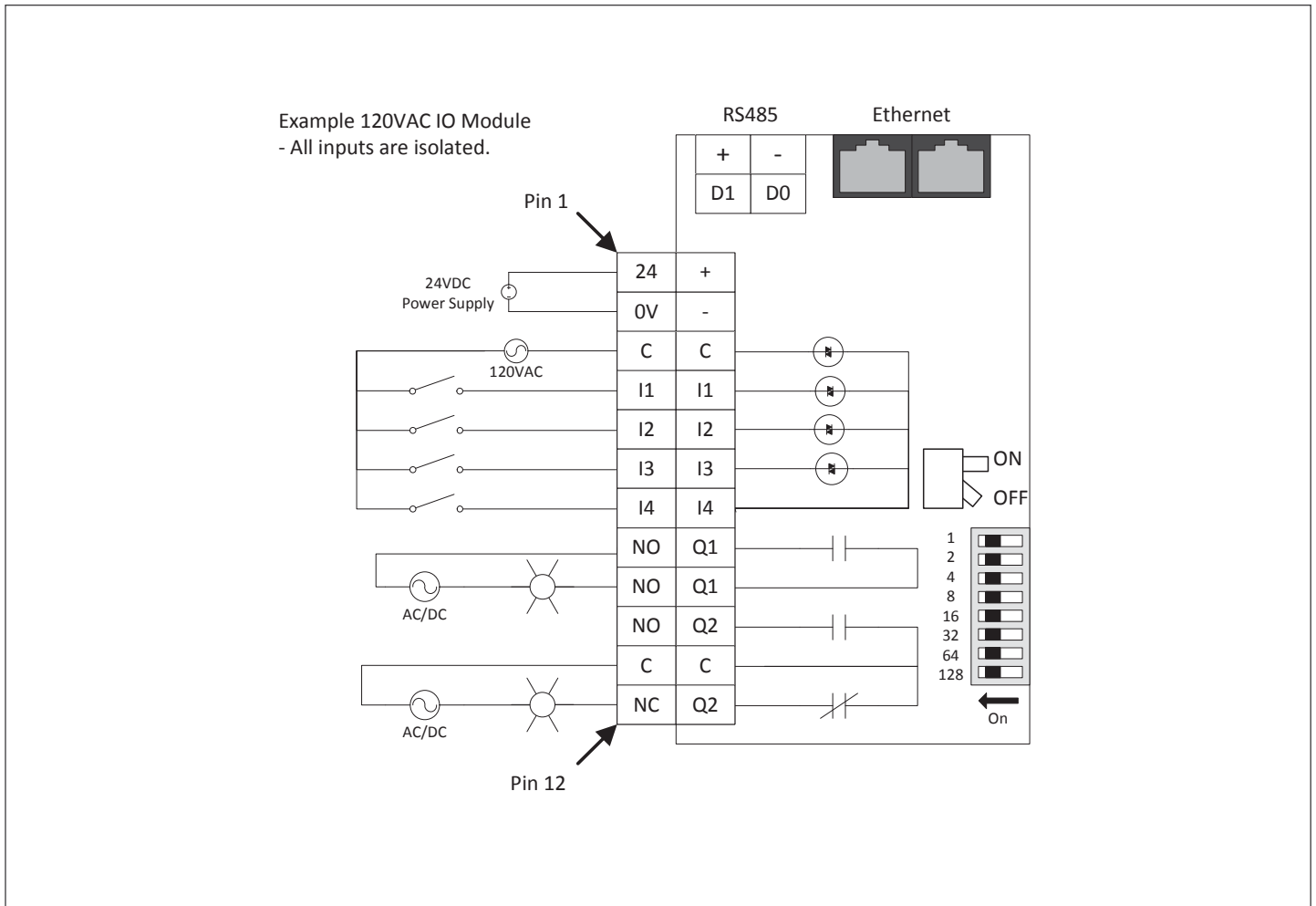

Figure 11. Wiring for the C441R and C441U

#### 4.5 S811+ to C441U and C441V

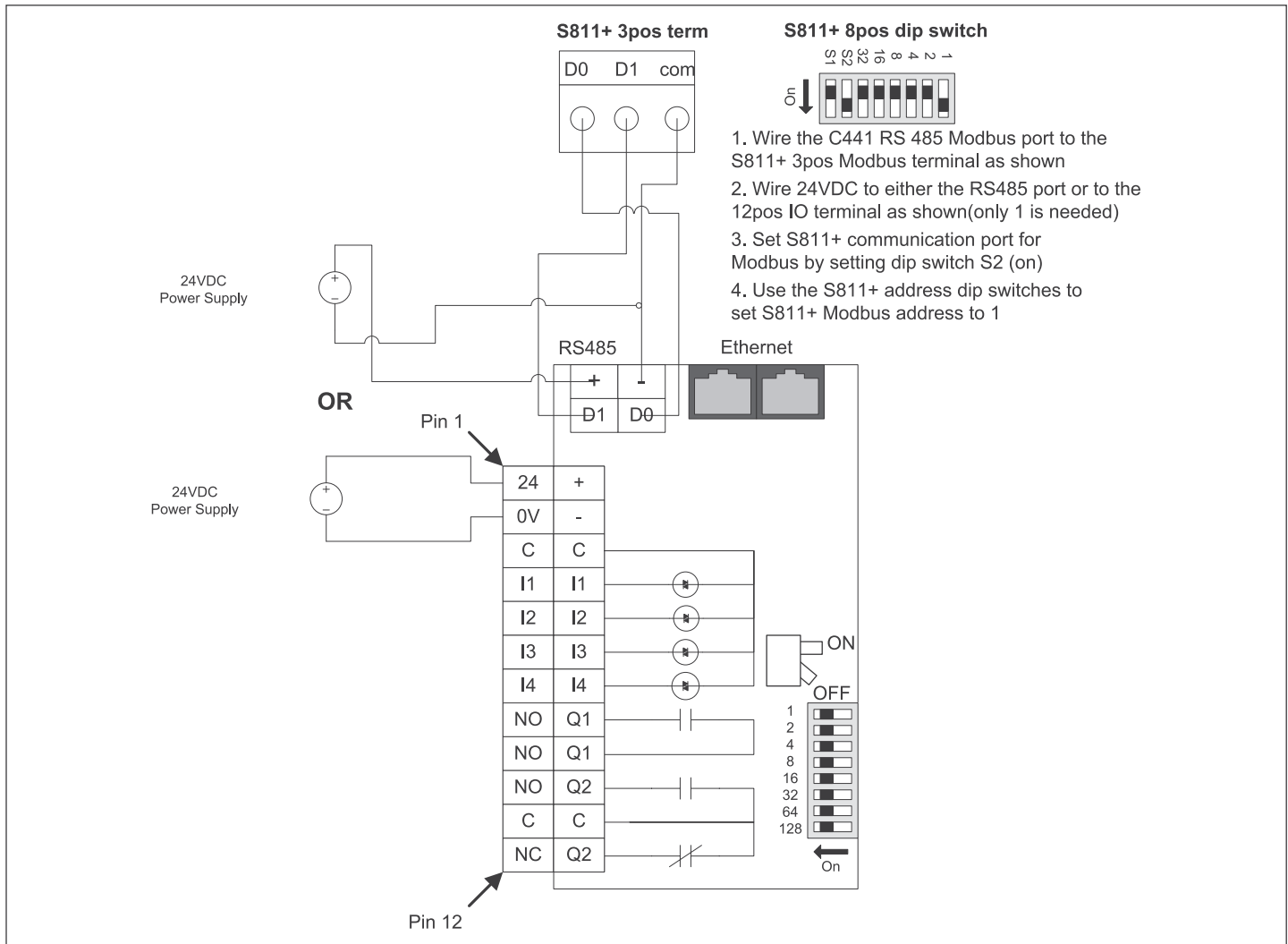

Figure 12. S811+ to C441U and C441V Wiring Diagram

#### 4.6 Status Indicators

The Ethernet module includes indicators for the module status (MS), Network Status (NS), Input Status (I1-I4) and Output Status (O1-O2).

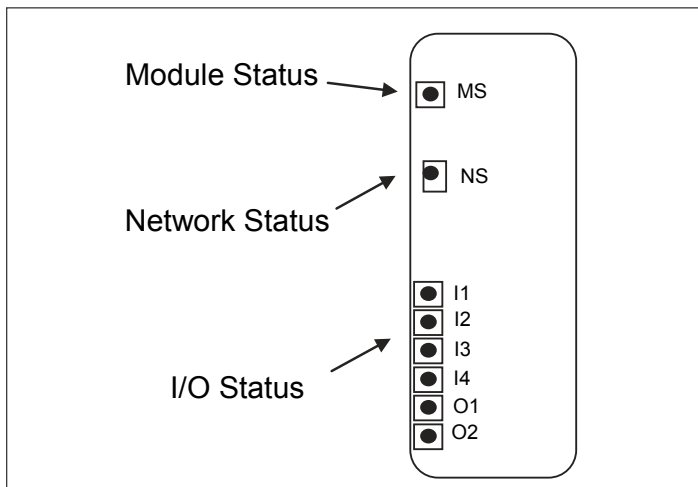

Figure 13. Status Indicators

The Module Status Indicator states are described in the table below

Table 10. Module Status Indicator

Indicator State	Summary	Requirement
Steady Off	No Power	If no power is supplied to the device, the module status indicator shall be steady off.
Steady Green	Device Operational	If the device is operating correctly, the module status indicator shall be steady green.
Flashing Green	Standby	If the device has not been configured, the module status indicator shall be flashing green.
Flashing Red	Minor Fault	If the device has detected a recoverable minor fault, the module status indicator shall be flashing red. <b>Note:</b> An incorrect or inconsistent configuration would be considered a minor fault. "This fault indication will be active when the target device (C441, C440, S611) is not powered up or not connected to the communication adapter. Check connections and attempt a power cycle of the communication adapter and target device."
Steady Red	Major Fault	If the device has detected a non-recoverable major fault, the module status indicator shall be steady red. This fault can be generated by an NV memory read failure. A factory reset should be attempted to clear the issue.
Flashing Green/Red	Self-test	While the device is performing its power up testing, the module status indicator shall be flashing green / red.

When operating with EtherNet/IP, the network status indicator states are described by the following table.

**Table 11. Network Status Indicator: Ether Net/IP**

Indicator State	Summary	Requirement
Steady Off	Not Powered No IP Address	The device is powered off, or is powered on but with no IP address configured (Interface Configuration attribute of the TCP/IP Interface Object).
Flashing Green	No Connections	An IP address is configured, but no CIP connections are established, and an Exclusive Owner connection has not timed out.
Steady Green	Connected	At least one CIP connection (any transport class) is established, and an Exclusive Owner connection (defined in Volume 1, Chapter 3) has not timed out.
Flashing Red	Connection Time-out	An Exclusive Owner connection (defined in Volume 1, Chapter 3) for which this device is the target has timed out. The network status indicator shall return to steady green only when all timed out Exclusive Owner connections are reestablished. Devices that support a single Exclusive Owner connection shall transition to steady green when any subsequent Exclusive Owner connection is established. Devices that support multiple Exclusive Owner connections shall retain the O->T connection path information when an Exclusive Owner connection times out. The Network LED shall transition from flashing red to steady green only when all connections to the previously timed-out O->T connection points are reestablished. Time-out of connections other than Exclusive Owner connections shall not cause the indicator to flash red. The Flashing Red state applies to target connections only. Originators and CIP Routers shall not enter this state when an originated or routed CIP connection times out.
Steady Red	Duplicate IP	If the device has detected a non-recoverable major fault, the module status indicator shall be steady red.
Flashing Green and Red	Self-test	While the device is performing its power up testing, the module status indicator shall be flashing green and red.

**Note:** When a single indicator is used to represent multiple IP address interfaces the state of any one interface shall be sufficient to modify the indicator state (per the above behavior in the table):

- Transition to flashing green when any one interface receives an IP address.
- Transition to steady green when a CIP connection is established on any interface (and Exclusive Owner is not timed out).
- Transition to flashing red when an Exclusive Owner CIP connection times out on any interface.
- Transition to steady red when any of the interfaces detects an IP address conflict.

When operating with Modbus TCP, the Network Status indicator states are described below.

**Table 12. Network Status Indicator: Modbus TCP**

Indicator State	Summary	Description
Steady Off	Not Powered, No IP Address	Device is not powered, or is powered with no IP address assigned.
Flashing Green	No Traffic	The device has an IP address, but no Modbus TCP traffic detected.
Flashing Yellow	Modbus TCP Traffic	The device is receiving Modbus TCP messages.

The Input Status Indicator states are described in the table below

**Table 13. Input Status (I1-I4) Indicator**

Indicator State	Description
Off	Field Input signal is off
On Solid	Field Input signal is on

The Output Status Indicator states are described in the table below.

**Table 14. Output Status (O1-O2) Indicator**

Indicator State	Description
Off	Field Output signal is off
On Solid	Field Output signal is on

#### 4.7 Configuration Reset Button

The configuration reset button performs the following functions:

Press Description	Action Taken
Press and release (under 5 seconds)	Performs LED test
Press and hold 5 seconds	Soft reset, same as power cycling the module. This allows new DIP switch settings to take effect.
Press and hold while cycling power	Factory Reset. All configuration values returned to default conditions.

## 5 Configuration

### 5.1 Configuration Using a Web Browser

The Ethernet module includes an embedded web page that provides the ability to monitor the status and set the configuration of the Motor Insight device and the Ethernet module.

The web pages have been validated for use with Internet Explorer.

To use the web page open your Internet Explorer browser and enter the IP address assigned to the Ethernet module:

`http:// IP Address`

The web page provides five levels of authorization as shown in the chart below:

Level	Default User Name	Default Password	Description
Open	<none>	<none>	Open access, has no password. Allows opening web page to be viewed, but no additional information is available
Read_Only	readonly	readonly	Read_Only access allows parameters to be viewed, but no control or configuration
Control	control	control	Control provides capabilities of Read_Only plus allows motor and discrete outputs to be turned on and off
Config	configuration	configuration	Config provides capabilities of Control plus the ability to set configuration values.
Super_User	superuser	superuser	Super_User provides the capabilities of Config plus the ability to change user names and passwords.

In addition to the individual levels, a **password exemption** setting is provided. This setting specifies a level that can be accessed without any password protection. **The default value of the password exemption is Super\_User.** All capabilities of the web page are accessible without a password prompt until the password exemption is changed to a lower level.

User names and passwords are case sensitive, and limited between 6–16 characters. For security reasons, it is recommended that the user change the default passwords and adjust the password exemption level to be lower than Super\_User after configuration. It is also recommended that these changes be made within a local subnet.

### 5.2 Configuration Using an EDS File

Multiple EDS files are available for the Ethernet Module depending on the configuration of the module:

- Connected to the C441 Motor Insight
- Connect to the C440 overload relay
- Connected to the S611 Soft Starter
- Connected to the S811+ Soft Starter
- Stand Alone I/O

These EDS file can be imported into any EtherNet/IP configuration tools that support EDS files.

The EDS files can be downloaded from the Eaton web site:

<http://www.eaton.com/electrical>

## 6 EtherNet/IP Protocol Support

### 6.1 Supported Connections

The Ethernet Module allows the Connected device to connect on EtherNet/IP. It can be connected both as an Explicit Message server and as an Implicit (I/O) message target.

The Implicit connections supported include:

- Exclusive Owner
- Listen Only
- Input Only

### 6.2 EtherNet/IP Object Model for C441 Motor Insight

#### Full Profile for Motor Insight

The table below shows the supported classes of the Ethernet Module when connected to a Motor Insight overload and monitoring relay.

Class	Object	# of Instances	Description
0x01 (hex)	Identity	1	Provides module identity object: See details below.
0x02	Message Router	1	Internal object implemented per ODVA specification.
0x04	Assembly Object	(See assembly object details)	Binds attributes from multiple objects for access with a single Implicit (I/O) connection. See details below.
0x06	Connection Manager	1	Internal object supporting connection management. Implemented per ODVA specification.
0x08	Discrete Input Point	4	Status information for the discrete Inputs. See details below.
0x09	Discrete Output Point	2	Status and control for the discrete Outputs. See details below.
0x29	Control Supervisor	1	Motor control functions. See details below.
0x2C	Overload	1	Motor overload protection. See details below.
0x93	Voltage Monitor	1	Vendor Specific object for monitoring motor voltage. See details below.
0xF5	TCP/IP Interface	1	Information about the TCP/IP Interface. Implemented per ODVA specification.
0xF6	Ethernet Link	2	Ethernet link object for each of the 2 Ethernet ports on the device. Implemented per ODVA specification.

#### Object Details

##### Identity Object

Class: 1 (0x01)

**Table 15. Instance Services**

Service Code	Service Name	Service Data	Description
0x05	Reset	0	Instance 1: Initializes adapter to the Power-up state.
0x05	Reset	1	Instance 1: Writes default values to all instance attributes AND then saves all non-volatile attributes to FLASH memory AND then performs the equivalent of a Reset(0).
0x05	Reset	101	Vendor specific reset — perform Intercom divorce.
0x0E	Get_Attribute_Single	n/a	Returns the value of the specified attribute.
0x10	Set_Attribute_Single	value	Sets the “value” into the specified attribute.



**Table 16. C441 Motor Insight Identity Object Instance Attributes**

Attrib	NV	Access	Data Type	Name	Description
1	V	Get	UINT	CIP Vendor ID	ODVA assigned Vendor Identification number.
2	V	Get	UINT	CIP Device Type	CIP defined general product type.
3	V	Get	UINT	Product Code	Vendor Product Code
4	V	Get	UINT	Firmware Rev	Com Adapter Firmware Rev.
5	V	Get	WORD	Device Status	This attribute represents the current status of the entire devices. Its value changes as the state of the device changes. Bit = Definition 0 = Owned. True indicates the device has an owner. 2 = Configured. True indicates the application of the device has been configured to do something different than out of box default. Does not include communication configuration. 4-7 = Extended Device Status. 8 = Minor Recoverable Fault. True indicates the device detected a problem with itself, which is thought to be recoverable. 9 = Minor Unrecoverable Fault. True indicates the device detected a problem with itself, which is thought to be unrecoverable. 10 = Major Recoverable Fault. True indicates the device detected a problem with itself causing a "Major Recoverable Fault" state. 11 = Major Unrecoverable Fault. True indicates the device detected a problem with itself causing a "Major Unrecoverable Fault" state.
6	NV	Set/Get	UDINT	Serial Number	32 bit Com Adapter Device Serial Number.
7	V	Get	SHORT_STRING	Product Name	ASCII product name.
8	V	Get	USINT	Device State	Present state of the device. Value = Definition 0 = Nonexistent 1 = Device Self Testing 2 = Standby 3 = Operational 4 = Major Recoverable Fault 5 = Major Unrecoverable Fault 255 = Default for Get Attributes All.
176	NV	Set/Get	SHORT_STRING	Assigned Name	User Defined ASCII Name.
177	V	Get	UINT	C441 DSP FW Version	C441 DSP Firmware Version
178	V	Get	UINT	UI Firmware Version	User Interface Firmware Version
179	NV	Set/Get	UINT	C441 Unit ID	Unit ID 0x00BA (186) - C441BA 0x00BB (187) - C441BB 0x00CA (202) - C441CA 0x00CB (203) - C441CB 0x00DA (218) - C441DA 0x00DB (219) - C441DB 0x00EA (234) - C4410109(x) 0x00EB (235) - C4410590(x)

Assembly Object  
Class: 4 (0x04)

**Table 17. C441 Motor Insight Assembly Object Instance Attributes**

Attrib	NV	Access	Data Type	Name	Description
3	V	Set/Get	Array of BYTE	Data	Assembly Data. See sections below for instance definition.

**Table 18. C441 Motor Insight Assembly Object Instances**

Type	Instance	Usage	Name
Output	2	Poll	Basic Output Overload
Output	105	Poll	Basic Overload w/Relay
Input	50	Poll	Fault Status
Input	51	Poll	Extended Input Overload
Input	100	Poll	Status and Current
Input	107	Poll	Extended Overload Input w/IO
Input	110	Poll	Status, Inputs and Measurements
Input	115	Poll	General Monitoring
Input	121	Poll	Status and Short Measurements

**Table 19. C441 Motor Insight Assembly Instance 2 (0x02): Basic Output Overload**

Byte Offset	Word Offset	Size (bytes)	Name	Description
0	0	1	Basic Output Overload	Bit 2: Fault Reset

Total Assembly Size (bytes): 1

**Table 20. C441 Motor Insight Assembly Instance 50 (0x32): Fault Status**

Byte Offset	Word Offset	Size (bytes)	Name	Description
0	0	1	Fault Status	Bit 0: Faulted.

Total Assembly Size (bytes): 1

**Table 21. C441 Motor Insight Assembly Instance 51 (0x33): Extended Input Overload**

Byte Offset	Word Offset	Size (bytes)	Name	Description
0	0	1	Extended Input Overload	Bit 0: Faulted Bit 1: Warning

Total Assembly Size (bytes): 1

**Table 22. C441 Motor Insight Assembly Instance 100 (0x64): Status and Current**

Assembly includes the status overview and motor current levels.  
Word Size (bytes): 2.  
All data is little endian (low byte first).

Byte Offset	Word Offset	Size (bytes)	Name	Description
0	0	2	Device Status	Device Bit Array Bit 0: Trip Bit 1: Warn Bit 2: Output #1 Bit 3: Output #2 Bit 4: Input #1 Bit 5: Input #2 Bit 6: Input #3 Bit 7: Input #4 Bit 8: Overload Power Lost Bit 9: Comm Adapter Low Voltage
2	1	2	Current I1	Phase A RMS Current, Unit: 90 Amp Models: x0.1A 9 Amp Models: x0.1A when external CTs are used; x0.01A otherwise (scale)
4	2	2	Current I2	Phase B RMS Current, Unit: 90 Amp Models: x0.1A 9 Amp Models: x0.1A when external CTs are used; x0.01A otherwise (scale)
6	3	2	Current I3	Phase C RMS Current, Unit: 90 Amp Models: x0.1A 9 Amp models: x0.1A when external CTs are used; x0.01A otherwise (scale)

Total Assembly Size (bytes): 8

**Table 23. C441 Motor Insight Assembly Instance 105 (0x69): Basic Overload w/Relay**

Byte Offset	Word Offset	Size (bytes)	Name	Description
0	0	1	Basic Overload w/Relay	Basic Overload with Relays. Bit 0 = Relay Output 1 Bit 1 = Relay Output 2 Bit 2 = Fault Reset Bit 3 = Aux Reset (CP Only) Bit 5 = Test Trip

Total Assembly Size (bytes): 1

**Table 24. C441 Motor Insight Assembly Instance 107 (0x6B): Extended Overload Input w/ IO**

Byte Offset	Word Offset	Size (bytes)	Name	Description
0	0	1	Extended Overload Input w/ IO	Extended Overload Assembly with IO. Bit 0 = Fault Bit 1 = Warning Bit 2 = Output 1 Bit 3 = Output 2 Bit 4 = Input 1 Bit 5 = Input 2 Bit 6 = Input 3 Bit 7 = Input 4

Total Assembly Size (bytes): 1

**Table 25. C441 Motor Insight Assembly Instance 110 (0x6E): Status, Inputs and Measurements**

Assembly includes general status, motor current, line voltage and Input states.  
Word Size (bytes): 2.  
All data is little endian (low byte first).

Byte Offset	Word Offset	Size (bytes)	Name	Description
0	0	2	Device Status	Device Bit Array Bit 0: Trip Bit 1: Warn Bit 2: Output #1 Bit 3: Output #2 Bit 4: Input #1 Bit 5: Input #2 Bit 6: Input #3 Bit 7: Input #4 Bit 8: Overload Power Lost Bit 9: Comm adapter low voltage
2	1	2	Current I1	Phase A RMS Current, Unit: 90 Amp Models: x0.1A 9 Amp Models: x0.1A when external CTs are used; x0.01A otherwise (scale)
4	2	2	Current I2	Phase B RMS Current, Unit: 90 Amp Models: x0.1A 9 Amp Models: x0.1A when external CTs are used; x0.01A otherwise (scale)
6	3	2	Current I3	Phase C RMS Current, Unit: 90 Amp Models: x0.1A 9 Amp models: x0.1A when external CTs are used; x0.01A otherwise (scale)
8	4	2	Trip Reason	0x0001 - Restart Attempts Exceeded 0x0002 - Relay turned off (network/UI) 0x0004 - Contactor Failure 0x0008 - Under Current Trip 0x0010 - Overload Trip 0x0020 - GND Fault Trip 0x0040 - Current Unbalance Trip 0x0080 - Current Single Phase 0x0100 - Reserved (0) 0x0200 - High Power Trip 0x0400 - Over Voltage Trip 0x0800 - Under Voltage Trip 0x1000 - Voltage Unbalance Trip 0x2000 - Over Current Trip 0x4000 - Low Power Trip 0x8000 - Phase Reversal Trip
10	5	2	Current Average	Average RMS Current, Unit: 90 Amp Models: x0.1A 9 Amp Models: x0.1A when external CTs are used; x0.01A otherwise (scale)
12	6	2	Voltage L1-L2	Phase A RMS Voltage L1-L2 (V)
14	7	2	Voltage L2-L3	Phase B RMS Voltage L2-L3 (V)
16	8	2	Voltage L3-L1	Phase C RMS Voltage L3-L1 (V)
18	9	2	Voltage Average	Average RMS Voltage (V)

Total Assembly Size (bytes): 20

**Table 26. C441 Motor Insight Assembly Instance 115 (0x73):  
General Monitoring**

Assembly includes most general measurements and states.  
Word Size (bytes): 2.  
All data is little endian (low byte first).

Byte Offset	Word Offset	Size (bytes)	Name	Description
0	0	2	Device Status	Device Bit Array Bit 0: Trip Bit 1: Warn Bit 2: Output #1 Bit 3: Output #2 Bit 4: Input #1 Bit 5: Input #2 Bit 6: Input #3 Bit 7: Input #4 Bit 8: Overload Power Lost Bit 9: Comm Adapter Low Voltage
2	1	2	Current I1	Phase A RMS Current, Unit: 90 Amp Models: x0.1A 9 Amp Models: x0.1A when external CTs are used; x0.01A otherwise (scale)
4	2	2	Current I2	Phase B RMS Current, Unit: 90 Amp Models: x0.1A 9 Amp Models: x0.1A when external CTs are used; x0.01A otherwise (scale)
6	3	2	Current I3	Phase C RMS Current, Unit: 90 Amp Models: x0.1A 9 Amp Models: x0.1A when external CTs are used; x0.01A otherwise (scale)
8	4	1	Field Inputs	A bitfield representing the input points. Bit = Description 0 = Input 1 1 = Input 2 2 = Input 3 3 = Input 4
10	5	2	Current Average	Average RMS Current, Unit: 90 Amp Models: x0.1A 9 Amp Models: x0.1A when external CTs are used; x0.01A otherwise (scale)
12	6	2	Voltage L1-L2	Phase A RMS Voltage L1-L2 (V)
14	7	2	Voltage L2-L3	Phase B RMS Voltage L2-L3 (V)
16	8	2	Voltage L3-L1	Phase C RMS Voltage L3-L1 (V)
18	9	2	Voltage Average	Average RMS Voltage (V)
20	10	2	Motor Power	Motor Power x0.1kW when external CTs are used x0.01kW otherwise (scale)
22	11	2	Voltage Unbalance Percentage	Max Deviation from Average Voltage Divided by Average Voltage (%).
24	12	2	Current Unbalance Percentage	Max Deviation from Average Current Divided by Average Current (%).
26	13	2	Apparent Power Factor	cos(phi), (real power)/(apparent power) (%)
28	14	2	Residual Ground Current	Residual Ground Current in Amps x 100 (x0.01A)
30	15	2	Line frequency	Line Frequency (x0.01Hz)

**Table 26. C441 Motor Insight Assembly Instance 115 (0x73):  
General Monitoring (Cont.)**

Byte Offset	Word Offset	Size (bytes)	Name	Description
32	16	2	Trip Reason	0x0001 - Restart Attempts Exceeded 0x0002 - Relay turned off (network/UI) 0x0004 - Contactor Failure 0x0008 - Under Current Trip 0x0010 - Overload Trip 0x0020 - GND Fault Trip 0x0040 - Current Unbalance Trip 0x0080 - Current Single Phase 0x0100 - Reserved (0) 0x0200 - High Power Trip 0x0400 - Over Voltage Trip 0x0800 - Under Voltage Trip 0x1000 - Voltage Unbalance Trip 0x2000 - Over Current Trip 0x4000 - Low Power Trip 0x8000 - Phase Reversal Trip
34	17	2	Overload Status	Overload Status - 0x0001: Overload Trip - 0x0002: Ground Fault Trip - 0x0004: High Power Trip - 0x0080: Relay Closed
36	18	2	Error Code	Warning/Alarm Indications 0x0001 (1) - Low Voltage Warning 0x0002 (2) - High Voltage Warning 0x0004 (4) - Voltage Unbalance Warning 0x0008 (8) - Low Power Warning 0x0010 (16) - Reverse Phase Warning 0x0020 (32) - Current Unbalance Warning 0x0040 (64) - Voltage Single Phase Warning 0x0080 (128) - Current Single Phase Warning 0x0100 (256) - GND Fault Warning
38	19	2	Thermal Pile Percentage	Thermal Capacity 0% Cold Motor 100% Will Cause an Overload Trip (%)
40	20	2	Aux Relay Trip Reason	0x0002 - Relay turned off (network/UI) 0x0004 - Contactor Failure 0x0008 - Under Current Trip 0x0010 - Overload Trip 0x0020 - GND Fault Trip 0x0040 - Current Unbalance Trip 0x0080 - Current Single Phase 0x0100 - Mains Freq Fault 0x0200 - High Power Trip 0x0400 - Over Voltage Trip 0x0800 - Under Voltage Trip 0x1000 - Voltage Unbalance Trip 0x2000 - Over Current Trip 0x4000 - Low Power Trip 0x8000 - Phase Reversal Trip

Total Assembly Size (bytes): 42

**Table 27. C441 Motor Insight Assembly Instance 121 (0x79): Status and Short Measurements**

Assembly includes general status and average current/voltage.  
Word Size (bytes): 2  
All data is little endian (low byte first).

Byte Offset	Word Offset	Size (bytes)	Name	Description
0	0	2	Device Status	Device Bit Array Bit 0: Trip Bit 1: Warn Bit 2: Output #1 Bit 3: Output #2 Bit 4: Input #1 Bit 5: Input #2 Bit 6: Input #3 Bit 7: Input #4 Bit 8: Overload Power Lost Bit 9: Comm Adapter Low Voltage
2	1	2	Current Average	Average RMS Current, Unit: 90 Amp Models: x0.1A 9 Amp Models: x0.1A when external CTs are used; x0.01A otherwise (scale)
4	2	2	Voltage Average	Average RMS Voltage (V)
6	3	2	Trip Reason	0x0001 - Restart Attempts Exceeded 0x0002 - Relay Turned Off (Network/UI) 0x0004 - Contactor Failure 0x0008 - Under Current Trip 0x0010 - Overload Trip 0x0020 - GND Fault Trip 0x0040 - Current Unbalance Trip 0x0080 - Current Single Phase 0x0100 - Reserved (0) 0x0200 - High Power Trip 0x0400 - Over Voltage Trip 0x0800 - Under Voltage Trip 0x1000 - Voltage Unbalance Trip 0x2000 - Over Current Trip 0x4000 - Low Power Trip 0x8000 - Phase Reversal Trip
8	4	2	Aux Relay Trip Reason	0x0002 - Relay turned off (network/UI) 0x0004 - Contactor Failure 0x0008 - Under Current Trip 0x0010 - Overload Trip 0x0020 - GND Fault Trip 0x0040 - Current Unbalance Trip 0x0080 - Current Single Phase 0x0100 - Mains Freq Fault 0x0200 - High Power Trip 0x0400 - Over Voltage Trip 0x0800 - Under Voltage Trip 0x1000 - Voltage Unbalance Trip 0x2000 - Over Current Trip 0x4000 - Low Power Trip 0x8000 - Phase Reversal Trip

Total Assembly Size (bytes): 10

**Discrete Input Object**  
Class:8 (0x08)

Instance Count: 4  
Instance List: 1, 2, 3, 4

**C441 Motor Insight Discrete Input Instance Attributes**

Attrib	NV	Access	Data Type	Name	Description
3		Get	BOOL	Input	Value of Input Point 0 = Off 1 = On
101	NV	Set/Get	UDINT	Field Inputs Debounce	The debounce applies to both rising and falling edge. (milliseconds)

**Discrete Output Object**  
Class: 9 (0x09)

Instance Count: 2  
Instance List: 1, 2

**Table 28. C441 Motor Insight Discrete Output Instance Attributes**

Attrib	NV	Access	Data Type	Name	Description
3	V	Set/Get	BOOL	Field Relay Outputs	Output point value Val = Description 0 = Off 1 = On
5	NV	Set/Get	BOOL	Field Relay Fault Action	When a communication fault occurs the output can execute two types of behavior. Value = Description 0 = Apply Fault Value 1 = No Change
6	NV	Set/Get	BOOL	Field Relay Fault State	Communication fault value to be applied. Value = Description 0 = Turn Relay Off 1 = Turn Relay On
7	NV	Set/Get	BOOL	Field Relay Idle Action	When a communication idle state occurs the relays can execute two types of behavior. Value = Description 0 = Apply Idle Value 1 = No Change
8	NV	Set/Get	BOOL	Field Relay Idle State	Communication idle value to be applied. Value = Description 0 = Turn Relay Off 1 = Turn Relay On

**Control Supervisor Object**  
Class: 0x29

**Table 29. Control Supervisor Instance Services**

Service Code	Service Name	Service Data	Description
0x0E	Get_Attribute_Single	n/a	Returns the value of the specified attribute
0x10	Set_Attribute_Single	value	Sets the "value" into the specified attribute
0x05	Reset	n/a	Resets the overload to the start-up state

**Table 30. C441 Motor Insight Control Supervisor Instance Attributes**

Attrib	NV	Access	Data Type	Name	Description
10	V	Get	BOOL	Fault Status	A Fault has occurred. Faults are latching and require a reset.
11	V	Get	BOOL	Warning Status	A Warning has occurred. Warnings self clear.
12	V	Set/Get	BOOL	Fault Reset	0->1 Causes a reset.
13	V	Get	UINT	Fault Queue	Fault Code and Fault Code List. When read as a single item it is the most recent fault. When read as a list, faults are listed in history order. Newest are at the beginning, oldest are at the end of the list. If the device is in the Faulted state, Fault Code indicates the fault that caused the transition to Faulted state. If not in the Faulted state, the Fault Code indicates the fault that caused the last transition to the Faulted state.
17	V	Set/Get	BOOL	Force Fault	0->1 = Force Fault 0 = No action
101	V	Get	WORD	Device Status	Device Bit Array Bit 0: Trip Bit1: Warn Bit2: Output #1 Bit3: Output #2 Bit4: Input #1 Bit5: Input #2 Bit6: Input #3 Bit7: Input #4 Bit8: Overload Power Lost Bit 9: Comm Adapter Low Voltage
102	V	Get	UINT	Trip Reason	0x0001 - Restart Attempts Exceeded 0x0002 - Relay Turned Off (Network/UI) 0x0004 - Contactor Failure 0x0008 - Under Current Trip 0x0010 - Overload Trip 0x0020 - GND Fault Trip 0x0040 - Current Unbalance Trip 0x0080 - Current Single Phase 0x0100 - Reserved (0) 0x0200 - High Power Trip 0x0400 - Over Voltage Trip 0x0800 - Under Voltage Trip 0x1000 - Voltage Unbalance Trip 0x2000 - Over Current Trip 0x4000 - Low Power Trip 0x8000 - Phase Reversal Trip
103	V	Get	UINT	Overload Status	Overload Status - 0x0001: Overload Trip - 0x0002: Ground Fault Trip - 0x0004: High Power Trip - 0x0080: Relay Closed
104	V	Get	UINT	Error Code	Warning/Alarm Indications 0x0001 (1) - Low Voltage Warning 0x0002 (2) - High Voltage Warning 0x0004 (4) - Voltage Unbalance Warning 0x0008 (8) - Low Power Warning 0x0010 (16) - Reverse Phase Warning 0x0020 (32) - Current Unbalance Warning 0x0040 (64) - Voltage Single Phase Warning 0x0080 (128) - Current Single Phase Warning 0x0100 (256) - GND Fault Warning
105	NV	Set/Get	BOOL	Motor Ctrl Idle Loss Act Disable	When this value is TRUE the motor state will be unchanged after a communication idle event. A FALSE value will cause the Motor Control Communication Idle Value to be applied on a com idle event.

**Table 30. C441 Motor Insight Control Supervisor Instance Attributes (Cont.)**

Attrib	NV	Access	Data Type	Name	Description
106	NV	Set/Get	BOOL	Motor Ctrl Com Idle Action Val	Action to execute when a communication loss event occurs. 0 = Ignore (No Change) 1 = Stop
107	NV	Set/Get	BOOL	Motor Ctrl Com Loss Act Disable	When this value is TRUE the motor state will be unchanged after a communication loss event. A FALSE value will cause the Motor Control Communication Loss Value to be applied on a com loss.
108	NV	Set/Get	BOOL	Motor Ctrl Com Loss Action Val	Action to execute when a communication loss event occurs. 0 = Ignore (No Change) 1 = Stop
109	V	Get	UINT	Fault Queue	Fault Code and Fault Code List. When read as a single item it is the most recent fault. When read as a list, faults are listed in history order. Newest are at the beginning, oldest are at the end of the list. If the device is in the Faulted state, Fault Code indicates the fault that caused the transition to Faulted state. If not in the Faulted state, the Fault Code indicates the fault that caused the last transition to the Faulted state.
110	V	Get	UINT	Fault Queue	Entry 1
111	V	Get	UINT	Fault Queue	Entry 2
112	V	Get	UINT	Fault Queue	Entry 3
113	V	Get	UINT	Fault Queue	Entry 4
114	V	Get	UINT	Fault Queue	Entry 5
115	V	Get	UINT	Fault Queue	Entry 6
116	V	Get	UINT	Fault Queue	Entry 7
117	V	Get	UINT	Fault Queue	Entry 8
118	V	Get	UINT	Fault Queue	Entry 9
119	V	Set/Get	BOOL	Clear Last Fault Entry From Queue	0->1 = Fault Entry Cleared 0 = No action
120	NV	Set/Get	UINT	Enable/Disable Trip	Trip Enable/Disable Bit Array: 0x0001 (1): Enable Ground Fault 0x0002 (2): Enable Voltage Unbalance 0x0004 (4): Enable Current Unbalance 0x0008 (8): Enable Under Current 0x0010 (16): Enable Phase Loss 0x0020 (32): Enable Jam 0x0040 (64): Enable Low Power 0x0080 (128): Enable High Power 0x0100 (256): Enable Over Voltage 0x0200 (512): Enable Under Voltage 0x0400 (1024): Enable Phase Order

**Table 30. C441 Motor Insight Control Supervisor Instance Attributes (Cont.)**

Attrib	NV	Access	Data Type	Name	Description
121	NV	Set/Get	WORD	Aux Relay Config Byte 1	Only available for 120 V Control Power models. Each bit of this configuration parameter enables (value 1) or disables (value 0) a fault for the auxiliary relay. The meanings of the bits are: 0x01: Ground Fault 0x02: Voltage Unbalance 0x04: Current Unbalance 0x08: Under Current 0x10: Phase Loss 0x20: Jam
122	NV	Set/Get	WORD	Aux Relay Config Byte 2	Only available for 120 V Control Power models. Each bit of this configuration parameter enables (value 1) or disables (value 0) a fault for the auxiliary relay. The meanings of the bits are: 0x01: Low Power 0x02: High Power 0x04: Over Voltage 0x08: Under Voltage 0x10: Phase Order 0x20: Overload 0x40: Supply Frequency Fault
123	NV	Set/Get	UINT	Aux Reset Delay	Only available for 120 V Control Power models. 0: Automatic reset of the auxiliary relay disabled 1 - 500: Automatic auxiliary relay reset delay since last auxiliary relay fault (min)
124	V	Get	WORD	Aux Relay Trip Reason	0x0002 - Relay Turned Off (Network/UI) 0x0004 - Contactor Failure 0x0008 - Under Current Trip 0x0010 - Overload Trip 0x0020 - GND Fault Trip 0x0040 - Current Unbalance Trip 0x0080 - Current Single Phase 0x0100 - Mains Freq Fault 0x0200 - High Power Trip 0x0400 - Over Voltage Trip 0x0800 - Under Voltage Trip 0x1000 - Voltage Unbalance Trip 0x2000 - Over Current Trip 0x4000 - Low Power Trip 0x8000 - Phase Reversal Trip
125 (0x7D)	V	Set/Get	BOOL	Reset Aux Relay	0->1 = Reset Aux 0 = No Action
126	NV	Set/Get	UINT	EtherNet/IP Com Loss Timeout Value	EtherNet/IP communication timeout Range: 0–60,000 ms Default: 3000 ms
127 <sup>Ⓢ</sup>	NV	Set/Get	UINT	Anti-backspin Time	A fault will be generated after every motor stop. No reset will be permitted during the backspin period. Range: 0–3600 sec

<sup>Ⓢ</sup> Supported by CP and HVR only.

**Overload Object Class 44 (0x2C)**

Instance Count: 1

Instance List: 1

**Table 31. Overload Object Instance Attributes**

Attrib	NV	Access	Data Type	Name	Description
4	NV	Set/Get	USINT	Overload Trip Class	Overload Trip Class
5	V	Get	INT	Current Average	Average RMS Current, Unit: 90 Amp Models: x0.1A 9 Amp Models: x0.1A when external CTs are used; x0.01A otherwise (scale)
6	V	Get	USINT	Current Unbalance Percentage	Max deviation from average current divided by average current (%).
7	V	Get	USINT	Thermal Pile Percentage	Thermal Capacity 0% Cold Motor 100% Will Cause and Overload Trip (%)
8	V	Get	INT	Current I1	Phase A RMS Current, Unit: 90 Amp Models: x0.1A 9 Amp Models: x0.1A when external CTs are used; x0.01A otherwise (scale)
9	V	Get	INT	Current I2	Phase B RMS Current, Unit: 90 Amp Models: x0.1A 9 Amp Models: x0.1A when external CTs are used; x0.01A otherwise (scale)
10	V	Get	INT	Current I3	Phase C RMS Current, Unit: 90 Amp Models: x0.1A 9 Amp Models: x0.1A when external CTs are used; x0.01A otherwise (scale)
11	V	Get	INT	Residual Ground Current	Residual Ground Current in Amps x 100 (x0.01A)
101	NV	Set/Get	UINT	Run Time Hours	Motor Run Time in Hours (resettable)
102	V	Get	UINT	Start Count	Start Count (Resettable)
103	NV	Set/Get	UINT	CT Multiplier	For 90 Amp Units: 1-4, number of conductors through CT. For 9 Amp Units: 1-2, number of conductors through CT; For 9 Amp Units, CT multipliers: 3 (150:5), 4 (300:5), 5 (600:5)
105	NV	Set/Get	UINT	Overload FLA	Motor Full Load Current (x0.01A)
106	V	Get	UINT	Apparent Power Factor	cos(phi), (real power)/(apparent power) (%)
107	V	Get	UINT	Motor Power	Motor Power x0.1kW when external CTs are used x0.01kW otherwise (scale)
108	V	Get	UINT	Remaining Normal Restart Delay	Motor Fault - Time to Restart (sec)
109	V	Get	UINT	Remaining Underload Trip Restart Delay	Load Fault - Time to Restart (sec)
110	NV	Set/Get	UINT	Load Fault Hold-off Time	Load Fault Reset Delay (min)
111	NV	Set/Get	UINT	Load Fault Number of Restarts	Load Fault Number of Reset Attempts 0: Manual 1-4 5: Automatic
112	NV	Set/Get	UINT	Motor Fault Hold-off Time	Motor Fault Reset Delay (min)

**Table 31. Overload Object Instance Attributes (Cont.)**

Attrib	NV	Access	Data Type	Name	Description
113	NV	Set/Get	UINT	Motor Fault Number of Restarts	Motor Fault Number of Attempts: 0: Manual 1-4 5: Automatic
114	NV	Set/Get	UINT	Run Transition Time	Run Transition Time (sec)
115	NV	Set/Get	UINT	Run Transition Percent	Run Transition % of FLA (%)
116	NV	Set/Get	UINT	Ground Fault Trip Mode	Ground Fault Trip Mode 0 - Trip on Ground Fault 1 - Alarm No Trip
117	NV	Set/Get	UINT	Ground Fault Trip Delay	Ground Fault Pickup Delay (sec)
118	NV	Set/Get	UINT	Ground Fault Pick-up Level	Ground Fault Pick-up Level (x0.01A)
119	NV	Set/Get	UINT	Current Unbalance Trip Delay	Current Unbalance Trip Delay (sec)
120	NV	Set/Get	UINT	Current Unbalance Pick-up Level	Current Unbalance Pick-up Level (%)
121	NV	Set/Get	UINT	Jam Trip Delay	Jam Trip Delay (sec)
122	NV	Set/Get	UINT	Jam Pick-up Level	Jam Pick-up Level (%)
123	NV	Set/Get	UINT	Current Phase Loss Trip Delay	Pickup Delay for Current Phase Loss (sec)
124	NV	Set/Get	UINT	High KW Trip Time	High Power Trip Delay (sec)
125	NV	Set/Get	UINT	High KW Trip limit	High Power Pick-up Level (x0.01kW)
126	NV	Set/Get	UINT	Low Power Trip Delay	Low Power Trip Delay (sec)
127	NV	Set/Get	UINT	Low Power Pick-up Level	Low Power Pick-up Level (x0.01kW)
128	NV	Set/Get	UINT	Under Current Trip Delay	Under Current Trip Delay (sec)
129	NV	Set/Get	UINT	Under Current Pick-up Level	Under Current Pick-up Level (%)
130	NV	Set/Get	UINT	Overload Reset	Overload Reset Mode 0: Manual Reset 1: Apply Motor Fault Reset Delay and Number of Attempts
131	NV	Set/Get	UINT	Load Fault Reset Delay Calc	Load Fault Reset Delay Calculator Enable. Value = Description 0 = Disable (default) 1 = Enabled
132 ①	NV	Set/Get	BOOL	Overload on Start Enable	0 = Disable 1 = Enable
133 ①	NV	Set/Get	BOOL	GF on Start Enable	0 = Disable 1 = Enable

① Supported by CP and HVR only.

**Voltage Monitor Object  
Class 147 (0x93):**

Instance Count: 1  
Instance List: 1

**Table 32. Voltage Monitor Object Instance Attributes**

Attrib	NV	Access	Data Type	Name	Description
1	V	Get	UINT	Voltage L1-L2	Phase A RMS Voltage L1-L2 (V)
2	V	Get	UINT	Voltage L2-L3	Phase B RMS Voltage L2-L3 (V)
3	V	Get	UINT	Voltage L3-L1	Phase C RMS Voltage L3-L1 (V)
4	V	Get	UINT	Voltage Average	Average RMS Voltage (V)
5	V	Get	UINT	Voltage Unbalance Percentage	Max Deviation from Average Voltage Divided by Average Voltage (%)
6	V	Get	UINT	Line Frequency	Line Frequency (x0.01Hz)
7	NV	Set/Get	UINT	Voltage Faults Trip Mode	Voltage Faults Trip Mode 0 - Trip On Supply Fault 1: Alarm-no-Trip (Inhibit Start)
8	NV	Set/Get	UINT	Under Voltage Pick-up Level	Under Voltage Pick-up Level (V)
9	NV	Set/Get	UINT	Under Voltage Trip Delay	Under Voltage Trip Delay (sec)
10	NV	Set/Get	UINT	Over Voltage Pick-up Level	Over Voltage Pick-up Level (V)
11	NV	Set/Get	UINT	Over Voltage Trip Delay	Over Voltage Trip Delay (sec)
12	NV	Set/Get	UINT	Voltage Unbalance Pick-up Level	Voltage Unbalance Pick-up Level (%)
13	NV	Set/Get	UINT	Voltage Unbalance Trip Delay	Voltage Unbalance Run Delay (sec)
14	NV	Set/Get	UINT	Phase Order	Phase Order - 0 (Trip Disabled) - 1 ACB - 2 ABC
15	NV	Set/Get	UINT	Supply Fault Hold-off Time	Restart Delay (sec)
16	V	Get	UINT	Remaining Rapid Cycling Restart Delay	Supply Fault - Time to Restart (sec)
100 ①	NV	Set/Get	UINT	Wire Config	0 = Three-phase 1 = Single-phase voltage and current 2 = Three-phase current only
101 ①	NV	Set/Get	UINT	PT Ratio	Indicates a PT ratio:120 step-down Range = 0 to 8000, 0 indicates no PT connection

**TCP/IP Interface Object  
Class 245 (0xF5):**

Instance Count: 1  
Instance List: 1

**Table 33. Object Attributes**

Attrib	NV	Access	Data Type	Name	Description
13	NV	Set/Get	UINT	Encapsulation Inactivity Timeout	Number of seconds of inactivity before TCP connection is closed

### 6.3 EtherNet/IP Object Model for C440 Overload Relay

When the Ethernet module is connected to a C440 overload relay, the presented object model is compliant with the ODVA Motor Overload device profile (type: 0x3).

#### Full Profile for C440

The table below shows the supported classes of the Ethernet Module when connected to an C440 overload relay.

Class	Object	# of Instances	Description
0x01 (hex)	Identity	1	Provides module identity object: See details below.
0x02	Message Router	1	Internal object implemented per ODVA specification
0x04	Assembly Object	5	Binds attributes from multiple objects for access with a single Implicit (I/O) connection. See details below.
0x06	Connection Manager	1	Internal object supporting connection management. Implemented per ODVA specification.
0x08	Discrete Input Point	4	Status information for the discrete Inputs. See details in previous section.
0x09	Discrete Output Point	2	Status and control for the discrete Outputs. See details in previous section.
0x29	Control Supervisor	1	Motor control functions. See details in previous section.
0x2C	Overload	1	Motor overload protection. See details below.
0xF5	TCP/IP Interface	1	Information about the TCP/IP Interface. Implemented per ODVA specification.
0xF6	Ethernet Link	2	Ethernet link object for each of the 2 Ethernet ports on the device. Implemented per ODVA specification.

### Object Details

#### Class 1 (0x01): Identity Object

Instance Count: 1

Instance List: 1

**Table 34. C440 Identity Object Instance Attributes**

Attrib	NV	Access	Data Type	Name	Description
1	V	Get	UINT	CIP Vendor ID	ODVA assigned Vendor Identification number.
2	V	Get	UINT	CIP Device Type	CIP defined general product type.
3	V	Get	UINT	Product Code	Vendor Product Code
4	V	Get	UINT	Firmware Rev	Com Adapter Firmware Rev.
5	V	Get	WORD	Device Status	This attribute represents the current status of the entire devices. Its value changes as the state of the device changes. Bit = Definition 0 = Owned. True indicates the device has an owner. 2 = Configured. True indicates the application of the device has been configured to do something different than out of box default. Does not include communication configuration. 4-7 = Extended Device Status. 8 = Minor Recoverable Fault. True indicates the device detected a problem with itself, which is thought to be recoverable. 9 = Minor Unrecoverable Fault. True indicates the device detected a problem with itself, which is thought to be unrecoverable. 10 = Major Recoverable Fault. True indicates the device detected a problem with itself causing a "Major Recoverable Fault" state. 11 = Major Unrecoverable Fault. True indicates the device detected a problem with itself causing a "Major Unrecoverable Fault" state.
6	NV	Set/Get	UDINT	Serial Number	32 bit Com Adapter Device Serial Number.
7	V	Get	SHORT_STRING	Product Name	ASCII product name.
8	V	Get	USINT	Device State	Present state of the device. Value = Definition 0 = Nonexistent 1 = Device Self Testing 2 = Standby 3 = Operational 4 = Major Recoverable Fault 5 = Major Unrecoverable Fault 255 = Default for Get Attributes All.
176	NV	Set/Get	SHORT_STRING	Assigned Name	User defined ASCII name.
177	V	Get	UINT	C441 DSP FW Version	C441 DSP Firmware Version
178	V	Get	UINT	UI Firmware Version	User Interface Firmware Version
179	NV	Set/Get	UINT	C441 Unit ID	Unit ID 0x00BA (186) - C441BA 0x00BB (187) - C441BB 0x00CA (202) - C441CA 0x00CB (203) - C441CB 0x00DA (218) - C441DA 0x00DB (219) - C441DB 0x00EA (234) - C4410109(x) 0x00EB (235) - C4410590(x)



Class 4 (0x04): Assembly Object

Instance Count: 6  
Instance List: 2, 50, 105, 107, 120, 130

**Table 35. C440 Assembly Object Instance Attributes**

Attrib	NV	Access	Data Type	Name	Description
3	V	Set/Get	Array of BYTE	Data	Assembly Data. See sections below for instance definition.

**Table 36. Assembly Instance List:**

Type	Instance	Usage	Name
Output	2	Poll	Basic Overload Output
Input	50	Poll	Fault Status
Output	105	Poll	Basic Overload Output w/Relay
Input	107	Poll	Basic Overload Output w/IO
Input	120	Poll	Status, Faults and Measurements
Input	130	Poll	Full Status and Measurements

Assembly Instance Definitions:

**Table 37. C440 Assembly Instance 2 (0x02): Basic Overload Output**

Byte Offset	Word Offset	Size (bytes)	Name	Description
0	0	1	Basic Overload Output	Bit 2: Fault Reset

Total Assembly Size (bytes): 1

**Table 38. C440 Assembly Instance 50 (0x32): Fault Status**

Byte Offset	Word Offset	Size (bytes)	Name	Description
0	0	1	Fault Status	Bit 0: Faulted

Total Assembly Size (bytes): 1

**Table 39. C440 Assembly Instance 105 (0x69): Basic Overload Output w/Relay**

Byte Offset	Word Offset	Size (bytes)	Name	Description
0	0	1	Basic Overload Output w/Relay	Basic Overload with Relays. Bit 0 = Relay Output 1 Bit 1 = Relay Output 2 Bit 2 = Fault Reset Bit 5 = Test Trip

Total Assembly Size (bytes): 1

**Table 40. C440 Assembly Instance 107 (0x6B): Basic Overload Output w/IO**

Byte Offset	Word Offset	Size (bytes)	Name	Description
0	0	1	Basic Overload Output w/IO	Basic Overload with Relays. Bit = Description 0 = Faulted 2 = Relay Output 1 3 = Relay Output 2 4 = Input 1 5 = Input 2 6 = Input 3 7 = Input 4

Total Assembly Size (bytes): 1

**Table 41. C440 Assembly Instance 120 (0x78): Status, Faults and Measurements**

Assembly includes the C440 status, faults, current and thermal value.  
Word Size (bytes): 2  
All data is little endian (low byte first).

Byte Offset	Word Offset	Size (bytes)	Name	Description
0	0	2	Device Status	Device Bit Array Bit 0: Tripped Bit 1: unused Bit 2: Output #1 Bit 3: Output #2 Bit 4: Input #1 Bit 5: Input #2 Bit 6: Input #3 Bit 7: Input #4 Bit 8: Overload Power Lost Bit 9: Comm Adapter Low Voltage Bit 10: 1=Running, 0=Stopped or Tripped Bit 11-15: Reserved
2	1	2	Latched Faults	Faults are cleared when the device is either reset by the network or detects current flowing. The fault bits are defined as follows: Bit Feature 0 Overload Fault 1 Phase Imbalance 2 Phase Loss Fault 3 Ground Fault 4 Network Trip Command 5 NV Memory Failure 6-> Reserved
4	2	2	Scaled 3 Phase Ave Current	Average of the 3 Scaled RMS Currents (Amps)
6	3	1	Thermal Memory Percentage	Present Thermal Value. 100% equates to a trip condition. (%)

Total Assembly Size (bytes): 8

**Table 42. C440 Assembly Instance 130 (0x82): Full Status and Measurements**

Assembly includes a full list of the most commonly used values.  
Word Size (bytes): 2.  
All data is little endian (low byte first).

Byte Offset	Word Offset	Size (bytes)	Name	Description
0	0	2	Device Status	Device Bit Array Bit 0: Tripped Bit 1: Unused Bit 2: Output #1 Bit 3: Output #2 Bit 4: Input #1 Bit 5: Input #2 Bit 6: Input #3 Bit 7: Input #4 Bit 8: Overload Power Lost Bit 9: Comm Adapter Low Voltage Bit 10: 1=Running, 0=Stopped or Tripped Bit 11-15: Reserved
2	1	2	Scaled Current Phase A RMS	Scaled RMS Current Phase A (Amps)
4	2	2	Scaled Current Phase B RMS	Scaled RMS Current Phase B (Amps)
6	3	2	Scaled Current Phase C RMS	Scaled RMS Current Phase C (Amps)
8	4	2	Scaled 3 Phase Ave Current	Average of the 3 Scaled RMS Currents (Amps)
10	5	2	Current as Percentage of FLA	Current as a Percentage of FLA. I.e: If Current is 1Amp and the FLA is 1AMP the percent would be 100%. (%)
12	6	1	Phase Imbalance Percent	Percent of Measured Phase Imbalance (%)
14	7	2	Line Frequency	The Line Frequency Measured by the Device. The frequency is displayed in deciHz. (Hertz)
16	8	1	Thermal Memory Percentage	Present Thermal Value. 100% equates to a trip condition. (%)
18	9	2	Latched Faults	Faults are cleared when the device is either reset by the network or detects current flowing. The fault bits are defined as follows: Bit Feature 0 Overload Fault 1 Phase Imbalance 2 Phase Loss Fault 3 Ground Fault 4 Network Trip Command 5 NV Memory Failure 6-> Reserved
20	10	2	Feature States	The feature status bits are defined as follows: Bit Feature 01 Class Index (00 = Class 10; 01 = Class 15; 10 = Class 20; 11 = Class 30) 2 Phase Loss/Imbalance Enabled 3 Ground Fault Enabled 4 Auto Reset Enabled 5 Remote Reset Active 6 Dip Switch Position 0 7 Dip Switch Position 1 8 Dip Switch Position 2 9 Dip Switch Position 3 10-15 Reserved
22	11	2	Device Temperature	The Temperature as Seen by the Microcontroller. Accuracy ~ 10%. (&#176;C)
24	12	2	Scaled Ground Current RMS	Scaled Ground Current. (Amps)
26	13	1	Ground Fault Percent	Percent of Ground Fault Measured. GF% = GFC / ((.5)*FLA) (%)

Total Assembly Size (bytes): 28

Class 8 (0x08): Discrete Input Object

Instance Count: 4  
Instance List: 1, 2, 3, 4

**Table 43. C440 Discrete Input Instance Attributes**

Attrib	NV	Access	Data Type	Name	Description
3		Get	BOOL	Inputs	0 = Off 1 = On
101	NV	Set/Get	UDINT	Field Inputs Debounce	The debounce applies to both rising and falling edge. (milliseconds)

Class 9 (0x09): Discrete Output Object

Instance Count: 2  
Instance List: 1, 2

**Table 44. C440 Discrete Output Instance Attributes**

Attrib	NV	Access	Data Type	Name	Description
3	V	Set/Get	BOOL	Field Relay Outputs	Output point value Val = Description 0 = Off 1 = On
5	NV	Set/Get	BOOL	Field Relay Fault Action	When a communication fault occurs the output can execute two types of behavior. Value = Description 0 = Apply Fault Value 1 = No Change
6	NV	Set/Get	BOOL	Field Relay Fault State	Communication fault value to be applied. Value = Description 0 = Turn Relay Off 1 = Turn Relay On
7	NV	Set/Get	BOOL	Field Relay Idle Action	When a communication idle state occurs the relays can execute two types of behavior. Value = Description. 0 = Apply Idle Value 1 = No Change
8	NV	Set/Get	BOOL	Field Relay Idle State	Communication idle value to be applied. Value = Description 0 = Turn Relay Off 1 = Turn Relay On

Class 41 (0x29): Control Supervisor Object

Instance Count: 1  
Instance List: 1

**Table 45. C440 Control Supervisor Instance Attributes**

Attrib	NV	Access	Data Type	Name	Description
10	V	Get	BOOL	Fault Status	A Fault has occurred. Faults are latching and require a reset.
12	V	Set/Get	BOOL	Fault Reset	0->1 Causes a reset.
17	V	Set/Get	BOOL	Force Fault	0->1 = Force Fault 0 = No action
101	V	Get	WORD	Device Status	Device Bit Array Bit 0: Tripped Bit 1: Unused Bit 2: Output #1 Bit 3: Output #2 Bit 4: Input #1 Bit 5: Input #2 Bit 6: Input #3 Bit 7: Input #4 Bit 8: Overload Power Lost Bit 9: Comm Adapter Low Voltage Bit 10: 1=Running, 0=Stopped or Tripped Bit 11-15: Reserved
102	V	Get	UINT	Latched Faults	Faults are cleared when the device is either reset by the network or detects current flowing The fault bits are defined as follows: Bit Feature 0 Overload Fault 1 Phase Imbalance 2 Phase Loss Fault 3 Ground Fault 4 Network Trip Command 5 NV Memory Failure 6-> Reserved
103	V	Get	USINT	Motor Ctrl State	Motor Control States: 0 = Stopped 1 = Running 2,3 = Tripped 4 = Resetting
105	NV	Set/Get	BOOL	Motor Ctrl Idle Loss Act Disable	When this value is TRUE the motor state will be unchanged after a communication idle event. A FALSE value will cause the Motor Control Communication Idle Value to be applied on a com idle event.
106	NV	Set/Get	BOOL	Motor Ctrl Com Idle Action Val	Action to execute when a communication loss event occurs. 0 = Ignore (No Change) 1 = Stop
107	NV	Set/Get	BOOL	Motor Ctrl Com Loss Act Disable	When this value is TRUE the motor state will be unchanged after a communication loss event. A FALSE value will cause the Motor Control Communication Loss Value to be applied on a com loss.
108	NV	Set/Get	BOOL	Motor Ctrl Com Loss Action Val	Action to execute when a communication loss event occurs. 0 = Ignore (No Change) 1 = Stop

**Table 45. C440 Control Supervisor Instance Attributes (Cont.)**

Attrib	NV	Access	Data Type	Name	Description
130	V	Get	UINT	Feature States	The feature status bits are defined as follows: Bit Feature 01 Class Index (00 = Class 10; 01 = Class 15; 10 = Class 20; 11 = Class 30) 2 Phase Loss/Imbalance Enabled 3 Ground Fault Enabled 4 Auto Reset Enabled 5 Remote Reset Active 6 Dip Switch Position 0 7 Dip Switch Position 1 8 Dip Switch Position 2 9 Dip Switch Position 3 10-15 Reserved
131	V	Get	INT	Device Temperature	The temperature as seen by the microcontroller. Accuracy ~ 10%. (&#176;C)
132	V	Get	UINT	Line Frequency	The line frequency measured by the device. The frequency is displayed in deciHz. (Hertz)
133	NV	Set/Get	UINT	EtherNet/IP Comm Timeout	Range: 0–60,000 ms Default: 3000 ms

Class 44 (0x2C): Overload Object

Instance Count: 1  
Instance List: 1

Table 46. C440 Overload Object Instance Attributes

Attrib	NV	Access	Data Type	Name	Description
6	V	Get	USINT	Phase Imbalance Percent	Percent of Measured Phase Imbalance (%)
7	V	Get	USINT	Thermal Memory Percentage	Present Thermal Value. 100% equates to a trip condition. (%)
100	V	Get	USINT	Overload Class	The Present FLA Class. Class settings are device dependent.
105	V	Get	UINT	Scaled FLA Setting	The Present FLA Setting. The potentiometer selects this value. The value is scaled by the multiplier. (Amps)
140	V	Get	UINT	Scaled 3Phase Ave Current	Average of the 3 Scaled RMS Currents (Amps)
141	V	Get	UINT	Scaled Current Phase A RMS	Scaled RMS Current Phase A (Amps)
142	V	Get	UINT	Scaled Current Phase B RMS	Scaled RMS Current Phase B (Amps)
143	V	Get	UINT	Scaled Current Phase C RMS	Scaled RMS Current Phase C (Amps)
144	V	Get	UINT	Scaled Ground Current RMS	Scaled Ground Current. (Amps)
150	V	Get	UINT	Scaled Max FLA	This is the max FLA setting possible in this device. The value is scaled by the multiplier. (Amps)
151	V	Get	UINT	Scaled Min FLA	This is the min FLA setting possible in this device. The value is scaled by the multiplier. (Amps)
152	V	Get	UINT	Current Scale Value	This value indicates the multiplier applied to the current values. For example: If the multiplier is 10 then all currents are read out in deciamps. 1A => 10A. (Scale)
153	V	Get	UINT	Current as Percentage of FLA	Current as a percentage of FLA. ie: If Current is 1Amp and the FLA is 1AMP the percent would be 100%. (%)
154	V	Get	USINT	Ground Fault Percent	Percent of Ground Fault measured. GF% = GFC / ((.5)*FLA) (%)

6.4 EtherNet/IP Object Model for Soft Starter

When the Ethernet module is connected to an S611 soft starter, the presented object model is compliant with the ODVA Softstart Device profile (type: 0x17).

Full Profile for S611

The table below shows the supported classes of the Ethernet Module when connected to an S611 soft starter.

Class	Object	# of Instances	Description
0x01 (hex)	Identity	1	Provides module identity object: See details in previous section.
0x02	Message Router	1	Internal object implemented per ODVA specification.
0x04	Assembly Object	6	Binds attributes from multiple objects for access with a single Implicit (I/O) connection. See details below.
0x06	Connection Manager	1	Internal object supporting connection management. Implemented per ODVA specification.
0x08	Discrete Input Point	4	Status information for the discrete Inputs. See details in previous section.
0x09	Discrete Output Point	2	Status and control for the discrete Outputs. See details in previous section.
0x29	Control Supervisor	1	Motor control functions. See details in previous section.
0x2C	Overload	1	Motor overload protection. See details below.
0x2D	SoftStart	1	Soft start object see details below.
0x93	Voltage Monitor	1	Vendor Specific object for monitoring motor voltage. See details below.
0xF5	TCP/IP Interface	1	Information about the TCP/IP Interface. Implemented per ODVA specification.
0xF6	Ethernet Link	2	Ethernet link object for each of the 2 Ethernet ports on the device. Implemented per ODVA specification.

Object Details

Class 1 (0x01): Identity Object

Instance Count: 1  
Instance List: 1

Table 47. S611 Identity Object Instance Attributes

Attrib	NV	Access	Data Type	Name	Description
1	V	Get	UINT	CIP Vendor ID	ODVA Assigned Vendor Identification Number.
2	V	Get	UINT	CIP Device Type	CIP Defined General Product Type.
3	V	Get	UINT	Product Code	Vendor Product Code
4	V	Get	UINT	Firmware Rev	Com Adapter Firmware Rev.

**Table 47. S611 Identity Object Instance Attributes (Cont.)**

Attrib	NV	Access	Data Type	Name	Description
5	V	Get	WORD	Device Status	This attribute represents the current status of the entire devices. Its value changes as the state of the device changes. Bit = Definition 0 = Owned. True indicates the device has an owner. 2 = Configured. True indicates the application of the device has been configured to do something different than out of box default. Does not include communication configuration. 4-7 = Extended Device Status. 8 = Minor Recoverable Fault. True indicates the device detected a problem with itself, which is thought to be recoverable. 9 = Minor Unrecoverable Fault. True indicates the device detected a problem with itself, which is thought to be unrecoverable. 10 = Major Recoverable Fault. True indicates the device detected a problem with itself causing a "Major Recoverable Fault" state. 11 = Major Unrecoverable Fault. True indicates the device detected a problem with itself causing a "Major Unrecoverable Fault" state.
6	NV	Set/Get	UDINT	Serial Number	32 bit Com Adapter Device Serial Number.
7	V	Get	SHORT-STRING	Product Name	ASCII Product Name.
8	V	Get	USINT	Device State	Present State of the Device. Value = Definition 0 = Nonexistent 1 = Device Self Testing 2 = Standby 3 = Operational 4 = Major Recoverable Fault 5 = Major Unrecoverable Fault 255 = Default for Get Attributes All.
176	NV	Set/Get	SHORT-STRING	Assigned Name	User Defined ASCII Name.
177	V	Get	UINT	C441 DSP FW Version	C441 DSP Firmware Version
178	V	Get	UINT	UI Firmware Version	User Interface Firmware Version
179	NV	Set/Get	UINT	C441 Unit ID	Unit ID 0x00BA (186) - C441BA 0x00BB (187) - C441BB 0x00CA (202) - C441CA 0x00CB (203) - C441CB 0x00DA (218) - C441DA 0x00DB (219) - C441DB 0x00EA (234) - C4410109(x) 0x00EB (235) - C4410590(x)

**Class 4 (0x04): Assembly Object**

Instance Count: 10  
Instance List: 3, 60, 100, 105, 106, 107, 108, 121, 131, 133

**Table 48. S611 Assembly Instance Attributes**

Attrib	NV	Access	Data Type	Name	Description
3	V	Set/Get	Array of BYTE	Data	Assembly Data. See sections below for instance definition.

**Table 49. S611 Assembly Instance List:**

Type	Instance	Usage	Name
Output	3	Poll	Basic Softstarter
Input	60	Poll	Basic Softstarter Input
Input	100	Poll	Status and Current
Output	105	Poll	Basic Overload w/Relay
Output	106	Poll	Extended Motor Ctrl
Input	107	Poll	Extended Overload w/ IO
Input	108	Poll	Motor Ctrl Status w/IO
Input	121	Poll	Status Measurement and Thermal
Input	131	Poll	Status and Enhanced Measurement
Input	133	Poll	Full S611 Monitoring

**Assembly Instance Definitions:**

**Table 50. S611 Assembly Instance 3 (0x03): Basic Softstarter**

Byte Offset	Word Offset	Size (bytes)	Name	Description
0	0	1	Basic Softstarter	Basic Softstart Assembly. Bit 0 = Run 1 Bit 2 = Fault Reset

Total Assembly Size (bytes): 1

**Table 51. S611 Assembly Instance 60 (0x3C): Basic Softstarter Input**

Byte Offset	Word Offset	Size (bytes)	Name	Description
0	0	1	Basic Softstarter Input	Basic Softstart. Bit 0 = Faulted Bit 2 = Running1 Bit 7 = Bypass (at Reference)

Total Assembly Size (bytes): 1

**Table 52. S611 Assembly Instance 100 (0x64): Status and Current**

Assembly includes the status overview and motor current levels.  
Word Size (bytes): 2  
All data is little endian (low byte first).

Byte Offset	Word Offset	Size (bytes)	Name	Description
0	0	2	Device Status	Device Bit Array, Bit: 0: Fault 1: Bypass 2: Running1 3: S611 Run/Aux Relay (Relay 1) 4: S611 Fault Relay (Relay 2) 5: CtrlFromNet 6: Permissive 7: Reserved 8: Output #1 9: Output #2 10: Input #1 11: Input #2 12: Input #3 13: Input #4 14: DeviceNet Low Power 15: S611 Intercom Lost
2	1	2	Phase A RMS Current	Scaled RMS current of phase A. (Amps)
4	2	2	Phase B RMS Current	Scaled RMS current of phase B. (Amps)
6	3	2	Phase C RMS Current	Scaled RMS current of phase C. (Amps)

Total Assembly Size (bytes): 8

**Table 53. S611 Assembly Instance 105 (0x69): Basic Overload w/ Relay**

Byte Offset	Word Offset	Size (bytes)	Name	Description
0	0	1	Basic Overload w/ Relay	Basic Overload with Relays Bit = Description Bit 0 = Relay Output 1 Bit 1 = Relay Output 2 Bit 2 = Fault Reset

Total Assembly Size (bytes): 1

**Table 54. S611 Assembly Instance 106 (0x6A): Extended Motor Ctrl**

Byte Offset	Word Offset	Size (bytes)	Name	Description
0	0	1	Extended Motor Ctrl	Extended Motor Control Bit = Description 0 = Run 1 1 = Permissive 2 = Fault Reset 6 = Output 1 7 = Output 2

Total Assembly Size (bytes): 1

**Table 55. S611 Assembly Instance 107 (0x6B): Extended Overload w/ IO**

Byte Offset	Word Offset	Size (bytes)	Name	Description
0	0	1	Extended Overload w/ IO	Extended Overload Assembly with IO. Bit = Description 0 = Fault 2 = Output 1 3 = Output 2 4 = Input 1 5 = Input 2 6 = Input 3 7 = input 4

Total Assembly Size (bytes): 1

**Table 56. S611 Assembly Instance 108 (0x6C): Motor Ctrl Status w/IO**

Byte Offset	Word Offset	Size (bytes)	Name	Description
0	0	2	Motor Ctrl Status w/IO	Motor Control Status Input Assembly. Bit = Description 0 = Fault 1 = Bypass 2 = Running 1 3 = S611 Run/Aux Relay 4 = S611 Fault Relay 5 = Control From Net 6 = Permissive 8 = Output 1 9 = Output 2 10 = Input 1 11 = Input 2 12 = Input 3 13 = Input 4 15 = S611 Internal Com Lost

Total Assembly Size (bytes): 2

**Table 57. S611 Assembly Instance 121 (0x79): Status Measurement and Thermal**

Includes the motor Ave Current, Thermal value and Ave Voltage monitoring.  
Word Size (bytes): 2.  
All data is little endian (low byte first).

Byte Offset	Word Offset	Size (bytes)	Name	Description
0	0	2	Device Status	Device Bit Array, Bit: 0: Fault 1: Bypass 2: Running1 3: S611 Run/Aux Relay (Relay 1) 4: S611 Fault Relay (Relay 2) 5: CtrlFromNet 6: Permissive 7: Reserved 8: Output #1 9: Output #2 10: Input #1 11: Input #2 12: Input #3 13: Input #4 14: DeviceNet Low Power 15: S611 Intercom Lost
2	1	2	Average Current	Average of the 3 Scaled RMS Currents. (Amps)
4	2	2	Average Voltage	Average of the 3 Scaled RMS Voltages (Volts)
6	3	2	Trip Reason	Bit = Description 0 = Overload 1 = Jam 2 = Stall 3 = Current Imbalance 4 = Load Disconnect 5 = Phase Loss 6 = Mains Fault 7 = Phase Reversal 8 = Shorted SCR 9 = SCR Not Firing 10 = Pole Overtemp 11 = Bypass Dropout 12 = SCR Overcurrent 13 = Contactor Overcurrent 14 = Communication Fault 15 = Other Device Fault

Total Assembly Size (bytes): 8

**Table 58. S611 Assembly Instance 131 (0x83): Status and Enhanced Measurement**

Includes the motor Current, Thermal value and Voltage monitoring.  
Word Size (bytes): 2  
All data is little endian (low byte first).

Byte Offset	Word Offset	Size (bytes)	Name	Description
0	0	2	Device Status	Device Bit Array, Bit: 0: Fault 1: Bypass 2: Running1 3: S611 Run/Aux Relay (Relay 1) 4: S611 Fault Relay (Relay 2) 5: CtrlFromNet 6: Permissive 7: Reserved 8: Output #1 9: Output #2 10: Input #1 11: Input #2 12: Input #3 13: Input #4 14: DeviceNet Low Power 15: S611 Intercom Lost
2	1	2	Phase A RMS Current	Scaled RMS Current of Phase A. (Amps)
4	2	2	Phase B RMS Current	Scaled RMS Current of Phase B. (Amps)
6	3	2	Phase C RMS Current	Scaled RMS Current of Phase C. (Amps)
8	4	2	Overload Thermal Memory	Thermal Capacity 0% Cold Motor 100% Will Cause an Overload Trip (%)
10	5	2	Average Current	Average of the 3 Scaled RMS Currents. (Amps)
12	6	2	Vab RMS Voltage	RMS Line-to-line Voltage Measured Between Phase A and B. (Volts)
14	7	2	Vbc RMS Voltage	RMS Line-to-line Voltage Measured Between Phase B and C. (Volts)
16	8	2	Vca RMS Voltage	RMS Line-to-line Voltage Measured Between Phase C and A. (Volts)
18	9	2	Average Voltage	Average of the 3 Scaled RMS Voltages (Volts)

Total Assembly Size (bytes): 20

**Table 59. S611 Assembly Instance 133 (0x85): Full S611 Monitoring**

Includes the most common measurement values.  
Word Size (bytes): 2  
All data is little endian (low byte first).

Byte Offset	Word Offset	Size (bytes)	Name	Description
0	0	2	Device Status	Device Bit Array, Bit: 0: Fault 1: Bypass 2: Running1 3: S611 Run/Aux Relay (Relay 1) 4: S611 Fault Relay (Relay 2) 5: CtrlFromNet 6: Permissive 7: Reserved 8: Output #1 9: Output #2 10: Input #1 11: Input #2 12: Input #3 13: Input #4 14: DeviceNet Low Power 15: S611 Intercom Lost
2	1	2	Phase A RMS Current	Scaled RMS Current of Phase A. (Amps)
4	2	2	Phase B RMS Current	Scaled RMS Current of Phase B. (Amps)
6	3	2	Phase C RMS Current	Scaled RMS Current of Phase C. (Amps)
8	4	1	Field Inputs	A bitfield representing the input points. Bit = Description 0 = Input 1 1 = Input 2 2 = Input 3 3 = Input 4
10	5	2	Average Current	Average of the 3 Scaled RMS Currents. (Amps)
12	6	2	Vab RMS Voltage	RMS Line-to-line Voltage Measured Between Phase A and B. (Volts)
14	7	2	Vbc RMS Voltage	RMS Line-to-line Voltage Measured Between Phase B and C. (Volts)
16	8	2	Vca RMS Voltage	RMS Line-to-line Voltage Measured Between Phase C and A. (Volts)
18	9	2	Average Voltage	Average of the 3 Scaled RMS Voltages (Volts)
20	10	2	Total Kilowatts	Scaled Total Kilowatts. Scale Factor is x10 (kW)
22	11	2	Voltage Unbalance	Voltage Unbalance Percent. (%)
24	12	2	Current Unbalance	Percent Current Phase Imbalance. (%)
26	13	2	Apparent Power Factor	Apparent Power Factor * 100
28	14	2	Residual Ground Fault Current	Scaled Residual Ground Fault Current. Scaling = x100
30	15	2	Line Frequency	Scaled Line Frequency. Scaling is x100. (Hz)

**Table 59. S611 Assembly Instance 133 (0x85): Full S611 Monitoring (Cont.)**

Byte Offset	Word Offset	Size (bytes)	Name	Description
32	16	2	Trip Reason	Bit = Description 0 = Overload 1 = Jam 2 = Stall 3 = Current Imbalance 4 = Load Disconnect 5 = Phase Loss 6 = Mains Fault 7 = Phase Reversal 8 = Shorted SCR 9 = SCR Not Firing 10 = Pole Overtemp 11 = Bypass Dropout 12 = SCR Overcurrent 13 = Contactor Overcurrent 14 = Communication Fault 15 = Other Device Fault
34	17	2	Motor Status	Motor Control Status Bits: Bit = Description 0 = Run 2 = In Bypass 5 = Fault 11 = Relay 1 State 12 = Relay 2 State 13 = Control From Network 14 = Permissive State
36	18	2	Pole Temp	Average Power Pole Temperature. Scaled = x10 (&#176;C).
38	19	2	Power Sign	Indicates Whether Power is Positive or Negative. In the Case of a Generator.
40	20	2	Current Scale Factor	Scale Factor for Current. Use this Value to Scale the Current Values.
42	21	2	Overload Thermal Memory	Thermal Capacity 0% Cold Motor 100% Will Cause an Overload Trip (%)

Total Assembly Size (bytes): 44

**Class 8 (0x08): Discrete Input Object**

Instance Count: 4  
Instance List: 1, 2, 3, 4

**Table 60. S611 Discrete Input Instance Attributes**

Attrib	NV	Access	Data Type	Name	Description
101	NV	Set/Get	UDINT	Field Inputs Debounce	The debounce applies to both rising and falling edge. (milliseconds).

**Class 9 (0x09): Discrete Output Object**

Instance Count: 2  
Instance List: 1, 2

**Table 61. S611 Discrete Output Instance Attributes**

Attrib	NV	Access	Data Type	Name	Description
3	V	Set/Get	BOOL	Field Relay Outputs	Output Point Value. Val = Description 0 = Off 1 = On
5	NV	Set/Get	BOOL	Field Relay Fault Action	When a communication fault occurs the output can execute two types of behavior. 0 = Apply Fault Value 1 = No Change
6	NV	Set/Get	BOOL	Field Relay Fault State	Communication fault value to be applied. Value = Description 0 = Turn Relay Off 1 = Turn Relay On
7	NV	Set/Get	BOOL	Field Relay Idle Action	When a communication idle state occurs the relays can execute two types of behavior. Value = Description 0 = Apply Idle Value 1 = No Change
8	NV	Set/Get	BOOL	Field Relay Idle State	Communication idle value to be applied. Value = Description 0 = Turn Relay Off 1 = Turn Relay On



Class 41 (0x29): Control Supervisor Object

Instance Count: 1  
Instance List: 1

**Table 62. S611 Control Supervisor Instance Attributes**

Attrib	NV	Access	Data Type	Name	Description
3	V	Set/Get	BOOL	Run1	Run the softstarter.
7	V	Get	BOOL	Running1	Indicates if the motor is running.
10	V	Get	BOOL	Fault Status	A Fault has occurred. Faults are latching and require a reset.
12	V	Set/Get	BOOL	Fault Reset	0->1 Causes a reset.
13	V	Get	UINT	Fault Code	If in faulted state, faultcode indicates the fault that caused the transition to the faulted state.
15	V	Get	BOOL	Control from Net	Control is coming from the network.
101	V	Get	WORD	Device Status	Device Bit Array, Bit: 0: Fault 1: Bypass 2: Running1 3: S611 Run/Aux Relay (Relay 1) 4: S611 Fault Relay (Relay 2) 5: CtrlFromNet 6: Permissive 7: Reserved 8: Output #1 9: Output #2 10: Input #1 11: Input #2 12: Input #3 13: Input #4 14: DeviceNet Low Power 15: S611 Intercom Lost
102	V	Get	UINT	Trip Reason	Bit = Description 0 = Overload 1 = Jam 2 = Stall 3 = Current Imbalance 4 = Load Disconnect 5 = Phase Loss 6 = Mains Fault 7 = Phase Reversal 8 = Shorted SCR 9 = SCR Not Firing 10 = Pole Overtemp 11 = Bypass Dropout 12 = SCR Overcurrent 13 = Contactor Overcurrent 14 = Communication Fault 15 = Other Device Fault
103	V	Get	UINT	Motor Status	Motor Control Status Bits: Bit = Description 0 = Run 2 = In Bypass 5 = Fault 11 = Relay 1 State 12 = Relay 2 State 13 = Control From Network 14 = Permissive State
105	NV	Set/Get	UINT	Network Timeout	Network Watchdog or Timeout enable. 0 = Disable 1 = Enable
106	NV	Set/Get	UINT	Communication Loss Behavior	1 = Fault 2 = Hold last state 3 = Stop (1)

**Table 62. S611 Control Supervisor Instance Attributes (Cont.)**

Attrib	NV	Access	Data Type	Name	Description
107	NV	Set/Get	BOOL	Motor Ctrl Com Loss Act Disable	When this value is TRUE the motor state will be unchanged after a communication loss event. A FALSE value will cause the Motor Control Communication Loss Value to be applied on a com loss.
108	NV	Set/Get	BOOL	Motor Ctrl Com Loss Action Val	Action to execute when a communication loss event occurs. 0 = Ignore (No Change) 1 = Stop
109	V	Get	UINT	Fault Code	Fault Code and Fault Code List. When read as a single item it is the most recent fault. When read as a list, faults are listed in history order. Newest are at the beginning, oldest are at the end of the list. If the device is in the Faulted state, Fault Code indicates the fault that caused the transition to Faulted state. If not in the Faulted state, the Fault Code indicates the fault that caused the last transition to the Faulted state.
110	V	Get	UINT	Fault Code	Entry 1
111	V	Get	UINT	Fault Code	Entry 2
112	V	Get	UINT	Fault Code	Entry 3
113	V	Get	UINT	Fault Code	Entry 4 .
114	V	Get	UINT	Fault Code	Entry 5
115	V	Get	UINT	Fault Code	Entry 6
116	V	Get	UINT	Fault Code	Entry 7
117	V	Get	UINT	Fault Code	Entry 8
118	V	Get	UINT	Fault Code	Entry 9
119	V	Set/Get	BOOL	Clear Fault Queue	Set this parameter to TRUE to clear the fault queue.
120	NV	Set/Get	UINT	Fault Enable Bits	Fault Enable Bits: Bit = Description 0 = Overload 1 = Jam 2 = Stall 3 = Current Imbalance 4 = Load Disconnect 5 = Phase Loss 6 = Under Voltage 7 = Over Voltage 8 = Voltage Unbalance 9 = Phase Reversal 10 = Ground Fault 11 = Overload On Start 12 = Shorted SCR 13 = SCR Not Firing 14 = Over Temperature
150	V	Set/Get	UINT	Motor Control	Motor Control Bits: Bit = Description 0 = Run 2 = Permissive 3 = Reset
151	NV	Set/Get	UINT	Start Input Behavior	Selects the behavior for the start input. When edge is selected, a start will only be performed on the rising edge of the start input. When level is selected, a start will occur any time the input is high. 0 = Edge 1 = Level
152	NV	Set/Get	UINT	Fault Relay Config	Fault Relay Configuration: 0 = Faulted 1 = Not Faulted

**Table 62. S611 Control Supervisor Instance Attributes (Cont.)**

Attrib	NV	Access	Data Type	Name	Description
153	NV	Set/Get	UINT	Auxiliary Relay Configuration	Auxiliary Relay Configuration Behavior: 0 = Faulted 1 = Not Faulted 2 = Bypass 3 = Not In Bypass 4 = Motor Energized 5 = Motor Not Energized
154	NV	Set/Get	UINT	User Interface Display Config	User Interface Display Configuration. Value = Description 0 = Thermal Capacity 1 = Power Factor 2 = Line Frequency 3 = Current Unbal % 4 = Voltage Unbalance % 5 = Average pole temp 6 = Pole A Temp 7 = Pole B Temp 8 = Pole C Temp
155	NV	Set/Get	UINT	UI Edit Lock	Provides the ability to prevent the user interface from making configuration changes. 0 = Unlocked 1 = Locked
156	V	Set/Get	UINT	Command Register	1 = Clear Motor Run Hours 2 = Clear Motor Start Count 3 = Clear fault queue 255 = Force Overload Rest (TP = 0) 250 = Force Comm Fault (unpublished)
157	NV	Set/Get	UINT	Communication Loss Timeout	Communication Loss Timeout Value (milliseconds)
158	NV	Set/Get	UINT	EtherNet/IP Comm Timeout	Range: 0–60,000 ms Default: 3000 ms

**Class 44 (0x2C): Overload Object**

Instance Count: 1

Instance List: 1

**Table 63. S611 Overload Object Instance Attributes**

Attrib	NV	Access	Data Type	Name	Description
4	NV	Set/Get	USINT	Overload Class	Overload Trip Class Setting.
6	V	Get	USINT	Current Unbalance	Percent Current Phase Imbalance. (%)
7	V	Get	USINT	Overload Thermal Memory	Thermal Capacity 0% Cold Motor 100% Will Cause an Overload Trip (%)
101	V	Get	UINT	Total Run Time	Run Time in Hours. Total run time can be reset through the command parameter. (Hours)
102	V	Get	UINT	Number of Starts	Total number of starts can be reset through the command parameter.
105	NV	Set/Get	UINT	Scaled Overload FLA	Scaled Overload FLA. Scaling factor is x10. (Amps)
106	V	Get	UINT	Apparent Power Factor	Apparent Power Factor * 100
107	V	Get	UINT	Total Kilowatts	Scaled Total Kilowatts. Scale factor is x10 (kW)
119	NV	Set/Get	UINT	Current Unbalance Trip Delay	Trip Delay Applied to the Unbalance Trip. (Seconds)
120	V	Get	UINT	Current Unbalance	Percent Current Phase Imbalance. (%)
121	NV	Set/Get	UINT	Jam Trip Delay	Jam Trip Delay in Seconds. (seconds)
122	NV	Set/Get	UINT	Jam Trip Level	Jam Trip Level Set in Percent of FLA. (%)
123	NV	Set/Get	UINT	Phase Loss Trip Delay	Trip Delay Applied to the Phase Loss Trip Sense. (seconds)
130	NV	Set/Get	UINT	Reset Mode	Method of Reset. 0 = Manual 1 = Auto
140	V	Get	UINT	Average Current	Average of the 3 Scaled RMS Currents. (Amps)
141	V	Get	UINT	Phase A RMS Current	Scaled RMS Current of Phase A. (Amps)
142	V	Get	UINT	Phase B RMS Current	Scaled RMS Current of Phase B. (Amps)
143	V	Get	UINT	Phase C RMS Current	Scaled RMS Current of Phase C. (Amps)
144	V	Get	UINT	Residual Ground Fault Current	Scaled Residual Ground Fault Current. Scaling = x100
152	V	Get	UINT	Current Scale Factor	Scale Factor for Current. Use this value to scale the current values.
170	NV	Set/Get	UINT	Load Disconnect Trip Level	Load Disconnect Trip Level as a Percent of Rated FLA. (%)
171	NV	Set/Get	UINT	Load Disconnect Trip Delay	Load Disconnect Trip Delay in Seconds. (seconds)
172	NV	Set/Get	UINT	Load Disconnect Source	Load Disconnect Source: 0 = Under Power 1 = Under Current
173	NV	Set/Get	UINT	Phase Loss Trip Level	Trip Level for a Phase Imbalance Trip. (%)
174	NV	Set/Get	UINT	Stall Trip Level	Stall Trip Level in Percent of FLA. (%)
175	V	Get	INT	Power Sign	Indicates whether power is positive or negative. In the case of a generator.
176	NV	Set/Get	UINT	Residual GF Start Delay	Length of time before the device will begin to acknowledge the ground fault current. (seconds)

Class 45 (0x2D): Softstart Object

Instance Count: 1  
Instance List: 1

**Table 64. S611 Softstart Object Instance Attributes**

Attrib	NV	Access	Data Type	Name	Description
3	V	Get	BOOL	At Ref	Indicates whether the softstart is in bypass or not.
4	NV	Set/Get	USINT	Soft Start Method	Selects the Ramp Start Method. 1=Voltage Ramp (no current limit) 2=Current Limit (no voltage ramp) 100=Pump start
7	NV	Set/Get	UINT	Start Time	Motor Start Ramp Time. (deciseconds)
13	NV	Set/Get	USINT	Kick Start Time	The Amount of Time to Apply a Kick Start. (deciseconds)
14	NV	Set/Get	UINT	Kick Start Initial Torque	Initial Torque Value for the Kick Start. (%)
16	NV	Set/Get	UINT	Stop Time	Motor Stop Ramp Time. Minimum time of 0 without pump option. Minimum time of 50 with pump stop enabled (deciseconds)
101	V	Get	INT	Phase A Pole Temp	Power Pole Temperature. Scaled = x10 (&#176;C)
102	V	Get	INT	Phase B Pole Temp	Power Pole Temperature. Scaled = x10 (&#176;C)
103	V	Get	INT	Phase C Pole Temp	Power Pole Temperature. Scaled = x10 (&#176;C)
104	V	Get	INT	Pole Temp	Average Power Pole Temperature. Scaled = x10 (&#176;C)
105	NV	Set/Get	UINT	Initial Motor Torque	Starting (Initial) Torque Percent.
106	NV	Set/Get	UINT	Pump Stop Time	If supported, the amount of time to use for the pump stop ramp behavior. (seconds)
107	NV	Set/Get	UINT	Start Method	Motor Start Method 0 = Vramp 1 = Limit 2 = Pump <b>Note:</b> If special function bit 0 is set, then pump option is available and set as the default, otherwise ramp start (0) is default
108	NV	Set/Get	UINT	Phase Sequence	Line Voltage Phase Sequence: 1 = ABC 2 = ACB

**6.5 EtherNet/IP Object Model for S811+ Soft Starter**

When the Ethernet module is connected to an S811+ soft starter, the presented object model is compliant with the ODVA Softstart Device profile (type: 0x17).

**Full Profile for S811+**

The table below shows the supported classes of the Ethernet Module when connected to an S811+ Soft Starter.

Class	Object	# of Instances	Description
0x01 (hex)	Identity	1	Provides module identity object: See details in previous section.
0x02	Message Router	1	Internal object implemented per ODVA specification
0x04	Assembly Object	16	Binds attributes from multiple objects for access with a single Implicit (I/O) connection. See details below.
0x06	Connection Manager	1	Internal object supporting connection management. Implemented per ODVA specification
0x08	Discrete Input Point	4	Status information for the discrete Inputs. See details in previous section.
0x09	Discrete Output Point	2	Status and control for the discrete Outputs. See details in previous section.
0x0A	Analog Input Point	1	Status and control for the Analog Input. See details below.
0x29	Control Supervisor	1	Motor control functions. See details in previous section.
0x2C	Overload	1	Motor overload protection. See details below.
0x20	SoftStart	1	Soft start object, See details below.
0x93	Voltage Monitor	1	Vendor Specific object for monitoring motor voltage. See details below.
0xF5	TCP/IP Interface	1	Information about the TCP/IP Interface. Implemented per ODVA specification
0xF6	Ethernet Link	2	Ethernet link object for each of the 2 Ethernet ports on the device. Implemented per ODVA specification.

**Object Details**

**Class 1 (0x01): Identity Object**

Instance Count: 1  
Instance List: 1

**Table 65. S811+ Identity Object Instance Attributes**

Attrib	NV	Access	Data Type	Name	Description
1	V	Get	UINT	CIP Vendor ID	ODVA Assigned Vendor Identification Number.
2	V	Get	UINT	CIP Device Type	CIP Defined General Product Type.
3	V	Get	UINT	Product Code	Vendor Product Code
4	V	Get	UINT	Firmware Rev	Com Adapter Firmware Rev.

**Table 65. S811+ Identity Object Instance Attributes (Cont.)**

Attrib	NV	Access	Data Type	Name	Description
5	V	Get	WORD	Device Status	This attribute represents the current status of the entire devices. Its value changes as the state of the device changes. Bit = Definition 0 = Owned. True indicates the device has an owner. 2 = Configured. True indicates the application of the device has been configured to do something different than out of box default. Does not include communication configuration. 4-7 = Extended Device Status. 8 = Minor Recoverable Fault. True indicates the device detected a problem with itself, which is thought to be recoverable. 9 = Minor Unrecoverable Fault. True indicates the device detected a problem with itself, which is thought to be unrecoverable. 10 = Major Recoverable Fault. True indicates the device detected a problem with itself causing a "Major Recoverable Fault" state. 11 = Major Unrecoverable Fault. True indicates the device detected a problem with itself causing a "Major Unrecoverable Fault" state.
6	NV	Set/Get	UDINT	Serial Number	32 bit Com Adapter Device Serial Number.
7	V	Get	SHORT_STRING	Product Name	ASCII Product Name.
8	V	Get	USINT	Device State	Present State of the Device. Value = Definition 0 = Nonexistent 1 = Device Self Testing 2 = Standby 3 = Operational 4 = Major Recoverable Fault 5 = Major Unrecoverable Fault 255 = Default for Get Attributes All.
176	NV	Set/Get	SHORT_STRING	Assigned Name	User Defined ASCII Name.
177	V	Get	UINT	C441 DSP FW Version	C441 DSP Firmware Version
178	V	Get	UINT	UI Firmware Version	User Interface Firmware Version
179	NV	Set/Get	UINT	C441 Unit ID	Unit ID 0x00BA (186) - C441BA 0x00BB (187) - C441BB 0x00CA (202) - C441CA 0x00CB (203) - C441CB 0x00DA (218) - C441DA 0x00DB (219) - C441DB 0x00EA (234) - C4410109(x) 0x00EB (235) - C4410590(x)

**Class 4 (0x04): Assembly Object**

Instance Count: 14

Instance List: 5, 60, 61, 101, 102, 110, 111, 120, 121, 130, 131, 140, 141, 150

Attrib	NV	Access	Data Type	Name	Description
3	V	Set/Get	Array of BYTE	Data	Assembly Data. See sections below for instance definition.

**Table 66. Assembly Instance List:**

Type	Instance	Usage	Name
Output	5 (0x05)	Poll	Extended Softstarter Output
Input	60 (0x3C)	Poll	Basic Softstarter Input
Input	61 (0x3D)	Poll	Extended Softstarter Input
Output	101 (0x65)	Poll	Extended Softstarter Output with Relay Outs
Input	102 (0x66)	Poll	Device Status
Input	110 (0x6E)	Poll	Status and Current(A)
Input	111 (0x6F)	Poll	Status and Current(0.1A)
Input	120 (0x78)	Poll	Status measurement and Thermal, Current in Amps
Input	121 (0x79)	Poll	Status measurement and Thermal. Current in 0.1A
Input	130 (0x82)	Poll	Status,Current,Voltage,Thermal, Current in Amps
Input	131 (0x83)	Poll	Status,Current,Voltage,Thermal, Current in 0.1A
Input	140 (0x8C)	Poll	Full S811 Monitoring, Current in Amps
Input	141 (0x8D)	Poll	Full S811 Monitoring, Current in 0.1A
Input	150 (0x96)	Poll	S811 Status

**Assembly Instance Definitions:**

All Assembly data is little endian (low byte first).

**Table 67. Assembly Instance 5 (0x05): Extended Softstarter Output**

Byte Offset	Word Offset	Size (bytes)	Name	Description
0	0	1	Extended Softstarter	Extended softstart assembly. Bit = Description 0 = Run 1 1 = Run 2 (Ramp2) 2 = Fault Reset

Total Assembly Size (bytes): 1

**Table 68. Assembly Instance 60 (0x3C): Basic Softstarter Input**

Byte Offset	Word Offset	Size (bytes)	Name	Description
0	0	1	Basic Softstarter Input	Basic softstart Input. Bit = Description 0 = Faulted 2 = Running1 7 = Bypass (at reference)

Total Assembly Size (bytes): 1

**Table 69. Assembly Instance 61 (0x3D): Extended Softstarter Input**

Byte Offset	Word Offset	Size (bytes)	Name	Description
0	0	1	Extended Softstarter Input	Extended Softstart Input Bit = Description 0 = Faulted 1 = Warning 2 = Running1 3 = Running2 (Ramp2) 4 = Ready 5 = CtrlFromNet 7 = Bypass (at reference).

Total Assembly Size (bytes): 1

**Table 70. Assembly Instance 101 (0x65): Extended Softstarter Output with Relay Outs**

Byte Offset	Word Offset	Size (bytes)	Name	Description
0	0	1	Extended Softstarter	Extended softstart assembly w relay outputs. Bit = Description 0 = Run 1 1 = Run 2 (Ramp2) 2 = Fault Reset 4 = C441 Q1 relay out 5 = C441 Q2 relay out

Total Assembly Size (bytes): 1

**Table 71. Assembly Instance 102 (0x66): Device Status**

Byte Offset	Word Offset	Size (bytes)	Name	Description
0	0	2	Device Status	Device Status Bit Array 0 Running - RUN command active 1 Jogging - Jog command active 2 Permissive - Start allowed (must be 1 to start) 3 Ramp2 - Ramp2 settings active 4 Local Control (0 - network; 1 - local) 5 Faulted - S811+ fault present 6 Warning - S811+ warning present (self clearing) 7 In bypass - S811+ Bypass closed 8 = Output 1 9 = Output 2 10 = Input 1 11 = Input 2 12 = Input 3 13 = Input 4 14 = Alarm No Trip Enabled 15 = S811+ Internal Comm Loss

Total Assembly Size (bytes): 2

**Table 72. Assembly Instance 110 (0x6E): Status and Current (A)**

Assembly includes the status overview and motor current levels scaled in Amps.  
Word Size (bytes): 2

Byte Offset	Word Offset	Size (bytes)	Name	Description
0	0	2	Device Status	Device Status Bit Array 0 Running - RUN command active 1 Jogging - Jog command active 2 Permissive - Start allowed (must be 1 to start) 3 Ramp2 - Ramp2 settings active 4 Local Control (0 - network; 1 - local) 5 Faulted - S811+ fault present 6 Warning - S811+ warning present (self clearing) 7 In bypass - S811+ Bypass closed 8 = Output 1 9 = Output 2 10 = Input 1 11 = Input 2 12 = Input 3 13 = Input 4 14 = Alarm No Trip Enabled 15 = S811+ Internal Comm Loss
2	1	6	3Ph RMS Line Current (amps)	Scaled RMS 3phase line current - This is the actual current flowing to the motor in 1.0A.

Total Assembly Size (bytes): 8

**Table 73. Assembly Instance 111 (0x6F): Status and Current (0.1A)**

Assembly includes the status overview and motor current levels scaled in 0.1As.  
Word Size (bytes): 2

Byte Offset	Word Offset	Size (bytes)	Name	Description
0	0	2	Device Status	Device Status Bit Array 0 Running - RUN command active 1 Jogging - Jog command active 2 Permissive - Start allowed (must be 1 to start) 3 Ramp2 - Ramp2 settings active 4 Local Control (0 - network; 1 - local) 5 Faulted - S811+ fault present 6 Warning - S811+ warning present (self clearing) 7 In bypass - S811+ Bypass closed 8 = Output 1 9 = Output 2 10 = Input 1 11 = Input 2 12 = Input 3 13 = Input 4 14 = Alarm No Trip Enabled 15 = S811+ Internal Comm Loss
2	1	6	3Ph RMS Line Current (deciamps)	Scaled RMS 3phase line current - This is the actual current flowing to the motor in 0.1A.

Total Assembly Size (bytes): 8

**Table 74. Assembly Instance 120 (0x78): Status measurement and Thermal (A)**

Includes the Motor status, motor Ave Current scaled in Amps and Thermal value  
Word Size (bytes): 2

Byte Offset	Word Offset	Size (bytes)	Name	Description
0	0	2	Device Status	Device Status Bit Array 0 Running - RUN command active 1 Jogging - Jog command active 2 Permissive - Start allowed (must be 1 to start) 3 Ramp2 - Ramp2 settings active 4 Local Control (0 - network; 1 - local) 5 Faulted - S811+ fault present 6 Warning - S811+ warning present (self clearing) 7 In bypass - S811+ Bypass closed 8 = Output 1 9 = Output 2 10 = Input 1 11 = Input 2 12 = Input 3 13 = Input 4 14 = Alarm No Trip Enabled 15 = S811+ Internal Comm Loss
2	1	2	3Ph Ave Line Current (amps)	Scaled RMS average of the 3 phase line current - This is the actual current flowing to the motor in 1.0A.
4	2	1	% Thermal Pile used	Thermal Pile Used Percentage - Trip at 100%
6	3	2	Motor Control Faults	S811+ Motor Control Fault Bit Field 0 Phaseloss 1 Phase Imbalance 2 Thermal Pile 3 Overcurrent 4 Breaker Fault 5 GND Fault 6 Motor Stall 7 Motor Jam 8 OverTemp 9 UnderLoad 10 Reserved 11 Estop 12 Reserved 13 Reserved 14 Reserved 15 Other

Total Assembly Size (bytes): 8

**Table 75. Assembly Instance 121 (0x79): Status measurement and Thermal (0.1A)**

Includes the Motor status, motor Ave Current scaled in 0.1A and Thermal value  
Word Size (bytes): 2

Byte Offset	Word Offset	Size (bytes)	Name	Description
0	0	2	Device Status	Device Status Bit Array 0 Running - RUN command active 1 Jogging - Jog command active 2 Permissive - Start allowed (must be 1 to start) 3 Ramp2 - Ramp2 settings active 4 Local Control (0 - network; 1 - local) 5 Faulted - S811+ fault present 6 Warning - S811+ warning present (self clearing) 7 In bypass - S811+ Bypass closed 8 = Output 1 9 = Output 2 10 = Input 1 11 = Input 2 12 = Input 3 13 = Input 4 14 = Alarm No Trip Enabled 15 = S811+ Internal Comm Loss
2	1	2	3Ph Ave Line Current (deciamps)	Scaled RMS average of the 3 phase line current - This is the actual current flowing to the motor in 0.1A.
4	2	1	% Thermal Pile used	Thermal Pile Used Percentage - Trip at 100%
6	3	2	Motor Control Faults	S811+ Motor Control Fault Bit Field 0 Phaseloss 1 Phase Imbalance 2 Thermal Pile 3 Overcurrent 4 Breaker Fault 5 GND Fault 6 Motor Stall 7 Motor Jam 8 OverTemp 9 UnderLoad 10 Reserved 11 Estop 12 Reserved 13 Reserved 14 Reserved 15 Other

Total Assembly Size (bytes)

**Table 76. Assembly Instance 130 (0x82):  
Status,Current,Voltage,Thermal (A)**

Assembly includes the status overview, motor current levels scaled in Amps, Pole Voltages & Thermal.  
Word Size (bytes): 2

Byte Offset	Word Offset	Size (bytes)	Name	Description
0	0	2	Device Status	Device Status Bit Array 0 Running - RUN command active 1 Jogging - Jog command active 2 Permissive - Start allowed (must be 1 to start) 3 Ramp2 - Ramp2 settings active 4 Local Control (0 - network; 1 - local) 5 Faulted - S811+ fault present 6 Warning - S811+ warning present (self clearing) 7 In bypass - S811+ Bypass closed 8 = Output 1 9 = Output 2 10 = Input 1 11 = Input 2 12 = Input 3 13 = Input 4 14 = Alarm No Trip Enabled 15 = S811+ Internal Comm Loss
2	1	6	3Ph RMS Line Current (amps)	Scaled RMS 3phase line current - This is the actual current flowing to the motor in 1.0A.
8	4	1	% Thermal Pile used	Thermal Pile Used Percentage - Trip at 100%
10	5	2	Average current as % FLA	Average of the 3 phase current as a percentage of the Motor Nameplate fla setting
12	6	6	3Ph RMS Mains Voltage	3 Phase RMS Mains voltage reading (in volts)

Total Assembly Size (bytes): 18

**Table 77. Assembly Instance 131 (0x83):  
Status,Current,Voltage,Thermal (0.1A)**

Assembly includes the status overview, motor current levels scaled in 0.1A, Pole Voltages & Thermal.  
Word Size (bytes): 2

Byte Offset	Word Offset	Size (bytes)	Name	Description
0	0	2	Device Status	Device Status Bit Array 0 Running - RUN command active 1 Jogging - Jog command active 2 Permissive - Start allowed (must be 1 to start) 3 Ramp2 - Ramp2 settings active 4 Local Control (0 - network; 1 - local) 5 Faulted - S811+ fault present 6 Warning - S811+ warning present (self clearing) 7 In bypass - S811+ Bypass closed 8 = Output 1 9 = Output 2 10 = Input 1 11 = Input 2 12 = Input 3 13 = Input 4 14 = Alarm No Trip Enabled 15 = S811+ Internal Comm Loss
2	1	6	3Ph RMS Line Current (deciamps)	Scaled RMS 3phase line current - This is the actual current flowing to the motor in 0.1A.
8	4	1	% Thermal Pile used	Thermal Pile Used Percentage - Trip at 100%
10	5	2	Average current as % FLA	Average of the 3 phase current as a percentage of the Motor Nameplate fla setting
12	6	6	3Ph RMS Mains Voltage	3 Phase RMS Mains voltage reading (in volts)

Total Assembly Size (bytes): 18

**Table 78. Assembly Instance 140 (0x8C): Full S811 Monitoring, Current in Amps**

Includes the most common measurement values. Current values scaled in Amps  
Word Size (bytes): 2

Byte Offset	Word Offset	Size (bytes)	Name	Description
0	0	2	Device Status	Device Status Bit Array 0 Running - RUN command active 1 Jogging - Jog command active 2 Permissive - Start allowed (must be 1 to start) 3 Ramp2 - Ramp2 settings active 4 Local Control (0 - network; 1 - local) 5 Faulted - S811+ fault present 6 Warning - S811+ warning present (self clearing) 7 In bypass - S811+ Bypass closed 8 = Output 1 9 = Output 2 10 = Input 1 11 = Input 2 12 = Input 3 13 = Input 4 14 = Alarm No Trip Enabled 15 = S811+ Internal Comm Loss
2	1	6	3Ph RMS Line Current (amps)	Scaled RMS 3phase line current - This is the actual current flowing to the motor in 1.0A.
8	4	2	3Ph Ave Line Current (amps)	Scaled RMS average of the 3phase line current - This is the actual current flowing to the motor in 1.0A.
10	5	2	Average current as % FLA	Average of the 3 phase current as a percentage of the Motor Nameplate fla setting
12	6	1	% Thermal Pile used	Thermal Pile Used Percentage - Trip at 100%
14	7	6	3Ph RMS Mains Voltage	3 Phase RMS Mains voltage reading (in volts)
20	10	2	Ave 3Ph Real Power (kW)	Average 3 phase real power (in kW)
22	11	2	Power Factor	Power factor reading 0 - 1.0000 (in 0.0001)
24	12	1	Field Inputs	A bitfield representing the input points. Bit = Description 0 = Input 1 1 = Input 2 2 = Input 3 3 = Input 4
26	13	6	Power Pole Temperature	S811+ power pole temperature in 0.1 degrees C
32	16	2	Line Frequency	Frequency reading of incoming mains voltage (in 0.01Hz)
34	17	2	Motor Control Faults	S811+ Motor Control Fault Bit Field Bit Fault 0 Phaseloss 1 Phase Imbalance 2 Thermal Pile 3 Overcurrent 4 Breaker Fault 5 GND Fault 6 Motor Stall 7 Motor Jam 8 OverTemp 9 UnderLoad 10 Reserved 11 Estop 12 Reserved 13 Reserved 14 Reserved 15 Other

**Table 78. Assembly Instance 140 (0x8C): Full S811 Monitoring, Current in Amps (Cont.)**

Byte Offset	Word Offset	Size (bytes)	Name	Description
36	18	2	Motor Control Warnings	S811+ Motor Control Warning Bit Field Bit Warning 0 Phaseloss 1 Phase Imbalance 2 Thermal Pile 3 Overcurrent 4 Breaker Fault 5 GND Fault 6 Motor Stall 7 Motor Jam 8 OverTemp 9 UnderLoad 10 Reserved 11 Reserved 12 Reserved 13 Reserved 14 Reserved 15 Other
38	19	6	Active Fault List	Will display up to 3 faults/warnings that are actively present
44	22	4	Total Motor Starts	Number of motor starts

Total Assembly Size (bytes): 48



**Table 79. Assembly Instance 141 (0x8D): Full S811 Monitoring, Current in 0.1A**

Includes the most common measurement values. Current values scaled in 0.1A  
Word Size (bytes): 2

Byte Offset	Word Offset	Size (bytes)	Name	Description
0	0	2	Device Status	Device Status Bit Array 0 Running - RUN command active 1 Jogging - Jog command active 2 Permissive - Start allowed (must be 1 to start) 3 Ramp2 - Ramp2 settings active 4 Local Control (0 - network; 1 - local) 5 Faulted - S811+ fault present 6 Warning - S811+ warning present (self clearing) 7 In bypass - S811+ Bypass closed 8 = Output 1 9 = Output 2 10 = Input 1 11 = Input 2 12 = Input 3 13 = Input 4 14 = Alarm No Trip Enabled 15 = S811+ Internal Comm Loss
2	1	6	3Ph RMS Line Current (deciamps)	Scaled RMS 3phase line current - This is the actual current flowing to the motor in 0.1A.
8	4	2	3Ph Ave Line Current (deciamps)	Scaled RMS average of the 3phase line current - This is the actual current flowing to the motor in 0.1A.
10	5	2	Average current as % FLA	Average of the 3 phase current as a percentage of the Motor Nameplate fla setting
12	6	1	% Thermal Pile used	Thermal Pile Used Percentage - Trip at 100%
14	7	6	3Ph RMS Mains Voltage	3 Phase RMS Mains voltage reading (in volts)
20	10	2	Ave 3Ph Real Power (kW)	Average 3 phase real power (in kW)
22	11	2	Power Factor	Power factor reading 0 - 1.0000 (in 0.0001)
24	12	1	Field Inputs	A bitfield representing the input points. Bit = Description 0 = Input 1 1 = Input 2 2 = Input 3 3 = Input 4
26	13	6	Power Pole Temperature	S811+ power pole temperature in 0.1 degrees C
32	16	2	Line Frequency	Frequency reading of incoming mains voltage (in 0.01Hz)
34	17	2	Motor Control Faults	S811+ Motor Control Fault Bit Field Bit Fault 0 PhaseLoss 1 Phase Imbalance 2 Thermal Pile 3 Overcurrent 4 Breaker Fault 5 GND Fault 6 Motor Stall 7 Motor Jam 8 OverTemp 9 UnderLoad 10 Reserved 11 Estop 12 Reserved 13 Reserved 14 Reserved 15 Other

**Table 79. Assembly Instance 141 (0x8D): Full S811 Monitoring, Current in 0.1A (Cont.)**

Byte Offset	Word Offset	Size (bytes)	Name	Description
36	18	2	Motor Control Warnings	S811+ Motor Control Warning Bit Field Bit Warning 0 PhaseLoss 1 Phase Imbalance 2 Thermal Pile 3 Overcurrent 4 Breaker Fault 5 GND Fault 6 Motor Stall 7 Motor Jam 8 OverTemp 9 UnderLoad 10 Reserved 11 Reserved 12 Reserved 13 Reserved 14 Reserved 15 Other
38	19	6	Active Fault List	Will display up to 3 faults/warnings that are actively present
44	22	4	Total Motor Starts	Number of motor starts

Total Assembly Size (bytes): 48

**Table 80. Assembly Instance 150 (0x96): S811 Status**

Includes S811 status, motor faults, motor warnings, & Active fault codes  
Word Size (bytes): 2

Byte Offset	Word Offset	Size (bytes)	Name	Description
0	0	2	Device Status	Device Status Bit Array 0 Running - RUN command active 1 Jogging - Jog command active 2 Permissive - Start allowed (must be 1 to start) 3 Ramp2 - Ramp2 settings active 4 Local Control (0 - network; 1 - local) 5 Faulted - S811+ fault present 6 Warning - S811+ warning present (self clearing) 7 In bypass - S811+ Bypass closed 8 = Output 1 9 = Output 2 10 = Input 1 11 = Input 2 12 = Input 3 13 = Input 4 14 = Alarm No Trip Enabled 15 = S811+ Internal Comm Loss
2	1	2	Motor Control Faults	S811+ Motor Control Fault Bit Field 0 Phaseloss 1 Phase Imbalance 2 Thermal Pile 3 Overcurrent 4 Breaker Fault 5 GND Fault 6 Motor Stall 7 Motor Jam 8 OverTemp 9 UnderLoad 10 Reserved 11 Estop 12 Reserved 13 Reserved 14 Reserved 15 Other
4	2	2	Motor Control Warnings	S811+ Motor Control Warning Bit Field 0 Phaseloss 1 Phase Imbalance 2 Thermal Pile 3 Overcurrent 4 Breaker Fault 5 GND Fault 6 Motor Stall 7 Motor Jam 8 OverTemp 9 UnderLoad 10 Reserved 11 Reserved 12 Reserved 13 Reserved 14 Reserved 15 Other
6	3	6	Active Fault List	Will display up to 3 faults/warnings that are actively present
12	6	20	Fault Queue	S811+ fault Queue Queue will hold up to the last 10 faults - Fault codes are not repeated in queue

Total Assembly Size (bytes): 32

**Table 81. Class 8 (0x08): Discrete Input Object**

Instance Count: 4  
Instance List: 1, 2, 3, 4

Attrib	NV	Access	Data Type	Name	Description
3 (0x03)	V	Get	BOOL	Input State	Input point value. Val = State 0 = Off 1 = On
101 (0x65)	NV	Set/Get	UDINT	On/Off debounce	The debounce time applied to the input. The debounce applies to both rising

**Table 82. Class 9 (0x09): Discrete Output Object**

Instance Count: 2  
Instance List: 1, 2

Attrib	NV	Access	Data Type	Name	Description
3 (0x03)	V	Set/Get	BOOL	Output State	Output point value. 0 = Off 1 = On
5 (0x05)	NV	Set/Get	BOOL	Com Fault Action	When a communication fault occurs the output can execute two types of behavior. Value = Description 0 = Apply Fault Value 1 = No Change
6 (0x06)	NV	Set/Get	BOOL	Com Fault Value	Communication fault value to be applied. Value = Description 0 = Turn Relay Off 1 = Turn Relay On
7 (0x07)	NV	Set/Get	BOOL	Idle Action	When a communication idle state occurs the relay can execute two types of behavior. Value = Description 0 = Apply Idle Value 1 = No Change
8 (0x08)	NV	Set/Get	BOOL	Idle Value	Communication idle value to be applied. Value = Description 0 = Turn Relay Off 1 = Turn Relay On

**Table 83. Class 10 (0x0A): Analog Input Object**

Instance Count: 1  
Instance List: 1

Attrib	NV	Access	Data Type	Name	Description
3 (0x03)	V	Get	USINT	Analog Input Value (% of range)	Analog input reading (in percent of set range)
8 (0x08)	V	Get	USINT	Analog Value Data Type	Analog Input Value Data Type 0 - INT 1 - REAL 2 - USINT 3 - SINT 4 - DINT 5 - LINT 6 - UINT 7 - UDINT 8 - ULINT 9 - LREAL 100 - (Vendor specific) USINT - Value in % of selected range (only format supported)
100 (0x64)	V	Get	USINT	Analog Input Status	Status of the S811+ analog input 0x00 - Not Active 0x01 - Input under range 0x02 - Input over range 0x03 - Input in overdrive 0x04 - Input is in range
101 (0x65)	NV	Set/Get	USINT	Analog Input Data Range	Selected range of analog input 0x02 0-20mA range 0x03 4-20mA range
102 (0x66)	NV	Set/Get	USINT	Analog Input Trip Enable	Analog input trip enable 0x00 - disable 0x01 - fault enable 0x02 - warning enable
103 (0x67)	NV	Set/Get	USINT	Analog Input Trip Low Threshold	Low analog input trip threshold (in percent of selected analog range)
104 (0x68)	NV	Set/Get	USINT	Analog Input Trip High Threshold	High analog input trip threshold (in percent of selected analog range)
105 (0x69)	NV	Set/Get	UINT	Analog Input Trip Duration	Amount of time a low or high analog input condition must exist before a trip; 0.0 - 60.0 (in 0.1secs)

**Table 84. Class 41 (0x29): Control Supervisor Object**

Instance Count: 1  
Instance List: 1

Attrib	NV	Access	Data Type	Name	Description
3 (0x03)	V	Set/Get	BOOL	Run1	Run the softstarter.
4 (0x04)	V	Set/Get	BOOL	Run2	Run the softstarter(ramp2)
7 (0x07)	V	Get	BOOL	Running1	Indicates if the motor is running standard ramp
8 (0x08)	V	Get	BOOL	Running2	Indicates if the motor is running ramp2
9 (0x09)	V	Get	BOOL	Ready	Softstarter is not faulted
10 (0x0A)	V	Get	BOOL	Faulted	Fault present
11 (0x0B)	V	Get	BOOL	Warning	Warning present
12 (0x0C)	V	Set/Get	BOOL	Fault Reset	Reset Fault
15 (0x0F)	V	Get	BOOL	Control From Net	Control is coming from the network.
22 (0x16)	V	Get	UDINT	Total motor starts	Total Motor Starts
100 (0x64)	NV	Set/Get	USINT	S811 Input1 cfg	Entry 1
101 (0x65)	NV	Set/Get	USINT	S811 Input2 cfg	Entry 2
102 (0x66)	NV	Set/Get	USINT	S811 Input3 cfg	Entry 3
103 (0x67)	NV	Set/Get	USINT	S811 Input4 cfg	Entry 4
104 (0x68)	NV	Set/Get	USINT	C441 Input1 cfg	Entry 5
105 (0x69)	NV	Set/Get	USINT	C441 Input2 cfg	Entry 6
106 (0x6A)	NV	Set/Get	USINT	C441 Input3 cfg	Entry 7
107 (0x6B)	NV	Set/Get	USINT	C441 Input4 cfg	Entry 8
108 (0x6C)	NV	Set/Get	USINT	S811 FormA relay cfg	Entry 1
109 (0x6D)	NV	Set/Get	USINT	S811 FormC relay cfg	Entry 2
110 (0x6E)	NV	Set/Get	USINT	C441 Output1 relay cfg	Entry 3
111 (0x6F)	NV	Set/Get	USINT	C441 Output2 relay cfg	Entry 4
112 (0x70)	NV	Set/Get	UINT	Custom fault code 1	Entry 1
113 (0x71)	NV	Set/Get	UINT	Custom fault code 2	Entry 2
114 (0x72)	NV	Set/Get	UINT	Custom fault code 3	Entry 3
115 (0x73)	NV	Set/Get	BOOL	Terminal Block control enable	Enables Local control at the terminal block
116 (0x74)	V	Get	BOOL	Run1 logic sense	Status of Run1 input logic sense (edge/level)
117 (0x75)	NV	Set/Get	BOOL	wiring config	0 - standard wiring; 1 - Inside the delta wiring
118 (0x76)	NV	Set/Get	BOOL	Pending start warning	Enables warning when start delay timers are used. Warning is issued while start command is pending
119 (0x77)	NV	Set/Get	UINT	Power up start delay	Time delay after power up before a start command can be issued
120 (0x78)	NV	Set/Get	UINT	Start delay	Time delay after a start command is issued before the S811+ will attempt start
121 (0x79)	NV	Set/Get	UINT	Run cmd start delay	User settable time delay between successive start profiles. Delay becomes active when start profile(ramp vs ramp2) changes between starts
122 (0x7A)	V	Get	UINT	Auto Reset Count	Number of auto reset attempts

**Table 84. Class 41 (0x29): Control Supervisor Object (Cont.)**

Attrib	NV	Access	Data Type	Name	Description
123 (0x7B)	NV	Set/Get	USINT	Fault Reset Mode	Fault reset mode 0x00 - manual reset 0x01 - auto reset 0x02 - power on reset (reset faults on power cycle)
124 (0x7C)	NV	Set/Get	UINT	Auto Reset Delay Time	Delay time after fault before attempting to auto reset
125 (0x7D)	NV	Set/Get	UINT	Auto Reset Attempt Limit	Max number of auto reset attempts; once reached, S811 requires manual reset to clear fault
126 (0x7E)	NV	Set/Get	USINT	Motor Comm Loss Action	Motor comloss action 0x00 - auto stop 0x01 - auto run1 0x02 - unavailable 0x03 - hold last state 0x04 - unavailable 0x05 - unavailable 0x06 - unavailable 0x07 - all stop fault (will trip S811+ and issue all stop fault)
127 (0x7F)	NV	Set/Get	UINT	Transient Motor Control Timeout	Motor control timeout for transient UI devices
128 (0x80)	NV	Set/Get	UINT	Motor Control Command Timeout	Motor control timeout - communication idle time which will cause a Motor Control Device Missing fault
129 (0x81)	V	Set/Get	USINT	Modbus Device Reset Register	Register performs reset services on S811+ over modbus 0x00 - no reset 0x01 - soft reset (power cycle reset) 0x02 - factory reset (reset device back to defaults) 0x03 - app parameter reset 0x04 - reserved 0x05 - reserved 0x06 - flush fault queue/list
130 (0x82)	NV	Set/Get	BOOL	Alarm - No Trip Enabled	Alarm no trip enable allows the S811+ to continue to run through any motor faults. Fault will be issued but will not stop the starter. Faults meant to protect the soft-starter will continue to trip the starter
131 (0x83)	NV	Set/Get	UINT	EtherNet/IP Comm Timeout	Range: 0–60,000 ms Default: 3000 ms

**Table 85. Class 44 (0x2C): Overload Object**

Instance Count: 1

Instance List: 1

Attrib	NV	Access	Data Type	Name	Description
4 (0x04)	NV	Set/Get	USINT	Overload Trip Class	Overload Trip Class ( 5 - 30; 20 default)
7 (0x07)	V	Get	USINT	% Thermal Pile used	Thermal Pile Used Percentage - Trip at 100%
100 (0x64)	V	Set/Get	UINT	Motor Nameplate FLA in 0.1A	Full load amperage rating of motor scaled in 0.1A (deci Amps)
101 (0x65)	V	Get	UINT	3Ph Ave Line Current (deciamps)	Scaled RMS average of the 3phase line current - This is the actual current flowing to the motor in 0.1A.
102 (0x66)	V	Get	UINT	3Ph RMS Line Current (deciamps)	Scaled RMS 3phase line current - This is the actual current flowing to the motor in 0.1A (L1).
103 (0x67)	V	Get	UINT	3Ph RMS Line Current (deciamps)	Scaled RMS 3phase line current - This is the actual current flowing to the motor in 0.1A (L2).
104 (0x68)	V	Get	UINT	3Ph RMS Line Current (deciamps)	Scaled RMS 3phase line current - This is the actual current flowing to the motor in 0.1A (L3).
105 (0x69)	V	Get	UINT	Average current as % FLA	Average of the 3 phase current as a percentage of the Motor Nameplate fla setting
106 (0x6A)	V	Get	UINT	3Ph Ave Line Current (amps)	Scaled RMS average of the 3phase line current - This is the actual current flowing to the motor in 1.0A.
107 (0x6B)	V	Get	UINT	3Ph RMS Line Current (amps)	Scaled RMS 3phase line current - This is the actual current flowing to the motor in 1.0A (L1).
108 (0x6C)	V	Get	UINT	3Ph RMS Line Current (amps)	Scaled RMS 3phase line current - This is the actual current flowing to the motor in 1.0A (L2).
109 (0x6D)	V	Get	UINT	3Ph RMS Line Current (amps)	Scaled RMS 3phase line current - This is the actual current flowing to the motor in 1.0A (L3).
110 (0x6E)	V	Get	UINT	Ave 3Ph Real Power (kW)	Average 3phase real power (in kW)
111 (0x6F)	V	Get	INT	Power Factor	Power factor reading 0 - 1.0000 (in 0.0001)
112 (0x70)	NV	Set/Get	USINT	Overload Trip Enable	Motor overload trip enable 0x00 - disable 0x01 - fault enable 0x02 - warning enable
113 (0x71)	V	Set/Get	BOOL	Enable Overload During Start	Enable the overload during start ramp 0x00 - overload is disabled during start ramp 0x01 - overload is enabled during start ramp
114 (0x72)	NV	Set/Get	USINT	Undercurrent Trip Enable	Low load current trip enable 0x00 - disable 0x01 - fault enable 0x02 - warning enable
115 (0x73)	NV	Set/Get	USINT	Undercurrent Trip Level (% FLA)	Low load current trip threshold in percent of the motor nameplate fla setting
116 (0x74)	NV	Set/Get	UINT	Undercurrent Trip Duration	Amount of time a low current condition must exist before a trip; 0.0 - 60.0 (in 0.1secs)
117 (0x75)	NV	Set/Get	USINT	Motor Jam Trip Enable	Motor jam trip enable 0x00 - disable 0x01 - fault enable 0x02 - warning enable
118 (0x76)	NV	Set/Get	USINT	Motor Stall Trip Enable	Motor stall trip enable 0x00 - disable 0x01 - fault enable 0x02 - warning enable

**Table 85. Class 44 (0x2C): Overload Object (Cont.)**

Attrib	NV	Access	Data Type	Name	Description
119 (0x77)	NV	Set/Get	USINT	Phase Loss Trip Enable	Motor phase loss trip enable 0x00 - disable 0x01 - fault enable 0x02 - warning enable
120 (0x78)	NV	Set/Get	USINT	Motor Phase Loss Trip Level	Current phase loss trip threshold
121 (0x79)	NV	Set/Get	UINT	Motor Phase Loss Duration	Amount of time a phase loss condition must exist before a trip; 0.0 - 60.0 (in 0.1secs)
122 (0x7A)	NV	Set/Get	USINT	Phase Imbalance Trip Enable	Current phase imbalance trip enable 0x00 - disable 0x01 - fault enable 0x02 - warning enable
123 (0x7B)	NV	Set/Get	USINT	Motor Phase Imbalance Trip Level	Current imbalance trip threshold
124 (0x7C)	NV	Set/Get	UINT	Motor Phase Imbalance Trip Duration	Amount of time a current imbalance condition must exist before a trip; 0.0 - 60.0 (in 0.1secs)
125 (0x7D)	NV	Set/Get	USINT	Ave Power Trip Enable	Average power trip enable 0x00 - disable 0x01 - fault enable 0x02 - warning enable
126 (0x7E)	NV	Set/Get	UINT	Ave Power Low Trip Threshold	Low power trip threshold (in percent of rated W) $\text{rated W} = \sqrt{3} * 0.8\text{PF} * \text{motor fla} * \text{rated motor voltage}$
127 (0x7F)	NV	Set/Get	UINT	Ave Power High Trip Threshold	High power trip threshold (in percent of rated W) $\text{rated W} = \sqrt{3} * 0.8\text{PF} * \text{motor fla} * \text{rated motor voltage}$
128 (0x80)	NV	Set/Get	UINT	Ave Power Trip Duration	Amount of time a low or high power condition must exist before a trip; 0.0 - 60.0 (in 0.1secs)

**Table 86. Class 45 (0x2D): Softstart Object**

Instance Count: 1  
Instance List: 1

Attrib	NV	Access	Data Type	Name	Description
3 (0x03)	V	Get	BOOL	At Ref	Indicates whether the softstart is in bypass or not.
4 (0x04)	NV	Set/Get	USINT	Soft Start Method	Selects the ramp start method. 1=Voltage Ramp (no current limit) 2=Current Limit (no voltage ramp) 100=Pump start
7 (0x07)	NV	Set/Get	UINT	Start Ramp Time	Motor start ramp time.
8 (0x08)	NV	Set/Get	USINT	Initial Starting Torque	Starting torque setting for ramp start
11 (0x0B)	NV	Set/Get	BOOL	Expected Incoming Phase Sequence	Expected phase sequence of incoming mains 0 - ABC 1 - ACB
16 (0x10)	NV	Set/Get	UINT	Stop Ramp Time	Motor stop ramp time. Parameter is not active when start method is set to pump
100 (0x64)	NV	Set/Get	UINT	Pump Stop Time	The amount of time to use for the pump stop ramp behavior. Parameter is active when pump-start is selected for motor start method
101 (0x0D)	NV	Set/Get	USINT	Kickstart Duration	The amount of time to apply a kick start 0.0 - 2.0 (in 0.1secs)
102 (0x0E)	NV	Set/Get	USINT	Kickstart Starting Torque	Initial torque value for the kick start
103 (0x65)	NV	Set/Get	USINT	Ramp2 Soft Start Method	Selects the ramp2 start method. 1=Voltage Ramp (no current limit) 2=Current Limit (no voltage ramp) 100=Pump start
104 (0x66)	NV	Set/Get	UINT	Ramp2 Start Ramp Time	Motor start ramp time for ramp2.
105 (0x67)	NV	Set/Get	USINT	Ramp2 Initial Starting Torque	Starting torque setting for ramp2 start
106 (0x68)	NV	Set/Get	BOOL	Ramp2 Expected Phase Sequence	Expected phase sequence of incoming mains for ramp2 start 1 - ACB
107 (0x69)	NV	Set/Get	USINT	Ramp2 Kickstart Duration	The amount of time to apply a kick start 0.0 - 2.0 (in 0.1secs) for ramp2 start
108 (0x6A)	NV	Set/Get	USINT	Ramp2 Kickstart Starting Torque	Initial torque value for the kick start for ramp2
109 (0x6B)	NV	Set/Get	UINT	Ramp2 Stop Ramp Time	Motor stop ramp time for ramp2. Parameter is not active when ramp2 start method is set to pump
110 (0x6C)	NV	Set/Get	UINT	Ramp2 Pump Stop Time	The amount of time to use for the pump stop ramp2 behavior. Parameter is active when pump-start is selected for ramp2 motor start method
111 (0x6D)	V	Get	INT	Power Pole Temperature	S811+ power pole temperature in 0.1 degrees C
112 (0x6E)	V	Get	INT	Power Pole Temperature	S811+ power pole temperature in 0.1 degrees C
113 (0x6F)	V	Get	INT	Power Pole Temperature	S811+ power pole temperature in 0.1 degrees C

**Table 86. Class 45 (0x2D): Softstart Object (Cont.)**

Attrib	NV	Access	Data Type	Name	Description
114 (0x70)	NV	Set/Get	USINT	Temperature Sensor Trip Enable	Temperature sensor trip enable 0x00 - disable 0x01 - fault enable 0x02 - warning enable
115 (0x71)	NV	Set/Get	USINT	SCR Not Firing Trip Enable	SCR not firing trip enable 0x00 - disable 0x01 - fault enable 0x02 - warning enable
116 (0x72)	NV	Set/Get	USINT	SCR Shorted Trip Enable	Shorted SCR trip enable 0x00 - disable 0x01 - fault enable 0x02 - warning enable

**Table 87. Class 140 (0x8C): Device Status Object**

Instance Count: 1

Instance List: 1

Attrib	NV	Access	Data Type	Name	Description
1 (0x01)	V	Get	USINT	Motor status	Motor Control Status Word for S811+ Bit Description 0 Running1 - RUN1 command active 1 Running2 - Jog command active 2 Permissive - Start allowed (must be 1 to start) 3 Ramp2 - Ramp2 settings active 4 Local Control (0 - network; 1 - local) 5 Faulted - S811+ fault present 6 Warning - S811+ warning present (self clearing) 7 In bypass - S811+ Bypass closed
2 (0x02)	V	Get	USINT	S811 input status	The Discrete data Input register will show the active/inactive status of S811+ hard-wired and networked inputs. Bits 3..0 indicate the status of the S811+ terminal block inputs and bits 7..4 indicate the status of the network inputs located in the Network Data Input Register (C441 communication adapter inputs#1- 4 when connected) Bit Description 0 S811+ discrete input#1 status 1 S811+ discrete input#2 status 2 S811+ discrete input#3 status 3 S811+ discrete input#4 status 4 Network input#1 status ( C441 Com adapter input#1) 5 Network input#2 status ( C441 Com adapter input#2) 6 Network input#3 status ( C441 Com adapter input#3) 7 Network input#4 status ( C441 Com adapter input#4)
3 (0x03)	V	Get	USINT	S811 output status	The Discrete data Output register bits 1..0 indicate the status of the S811+ relays and bits 3..2 indicate the status of the network outputs being generated by the S811+ configurable output logic(C441 communication adapter outputs#1- 2 when connected) Bit Description 0 S811+ discrete formA relay status 1 S811+ discrete formC relay status 2 Network output#1 status ( C441 Com adapter output#1) 3 Network output#2 status ( C441 Com adapter output#2) 4 5 6 7
4 (0x04)	V	Get	UINT	Active Fault #1	Will display up to 3 faults/warnings that are actively present
5 (0x05)	V	Get	UINT	Active Fault #2	Will display up to 3 faults/warnings that are actively present
6 (0x06)	V	Get	UINT	Active Fault #3	Will display up to 3 faults/warnings that are actively present
7 (0x07)	V	Get	UINT	Bit field (faults)	S811+ Motor Control Fault Bit Field Bit Fault 0 Phaseloss 1 Phase Imbalance 2 Thermal Pile 3 Overcurrent 4 Breaker Fault 5 GND Fault 6 Motor Stall 7 Motor Jam 8 OverTemp 9 UnderLoad 10 Reserved 11 Estop 12 Reserved 13 Reserved 14 Reserved 15 Other

**Table 87. Class 140 (0x8C): Device Status Object (Cont.)**

Attrib	NV	Access	Data Type	Name	Description
8 (0x08)	V	Get	UINT	Bit field (warnings)	S811+ Motor Control Warning Bit Field Bit Warning 0 Phase loss 1 Phase Imbalance 2 Thermal Pile 3 Overcurrent 4 Breaker Fault 5 GND Fault 6 Motor Stall 7 Motor Jam 8 OverTemp 9 UnderLoad 10 Reserved 11 Reserved 12 Reserved 13 Reserved 14 Reserved 15 Other
9 (0x09)	V	Get	UINT	Most recent fault	S811+ fault Queue Queue will hold up to the last 10 faults - Fault codes are not repeated in queue
10 (0x0A)	V	Get	UINT	next most recent fault	S811+ fault Queue Queue will hold up to the last 10 faults - Fault codes are not repeated in queue
11 (0x0B)	V	Get	UINT	next most recent fault	S811+ fault Queue Queue will hold up to the last 10 faults - Fault codes are not repeated in queue
12 (0x0C)	V	Get	UINT	next most recent fault	S811+ fault Queue Queue will hold up to the last 10 faults - Fault codes are not repeated in queue
13 (0x0D)	V	Get	UINT	next most recent fault	S811+ fault Queue Queue will hold up to the last 10 faults - Fault codes are not repeated in queue
14 (0x0E)	V	Get	UINT	next most recent fault	S811+ fault Queue Queue will hold up to the last 10 faults - Fault codes are not repeated in queue
15 (0x0F)	V	Get	UINT	next most recent fault	S811+ fault Queue Queue will hold up to the last 10 faults - Fault codes are not repeated in queue
16 (0x10)	V	Get	UINT	next most recent fault	S811+ fault Queue Queue will hold up to the last 10 faults - Fault codes are not repeated in queue
17 (0x11)	V	Get	UINT	next most recent fault	S811+ fault Queue Queue will hold up to the last 10 faults - Fault codes are not repeated in queue
18 (0x12)	V	Get	UINT	Oldest fault	S811+ fault Queue Queue will hold up to the last 10 faults - Fault codes are not repeated in queue
19 (0x13)	V	Set/Get	BOOL	Clear Fault Queue	Set this parameter to TRUE to clear the fault queue.

**Table 88. Class 147 (0x93): Voltage Monitor Object**

Instance Count: 1  
Instance List: 1

Attrib	NV	Access	Data Type	Name	Description
1 (0x01)	V	Get	UINT	3Ph RMS Mains Voltage	3 Phase RMS Mains voltage reading (in volts) (L1-L2)
2 (0x02)	V	Get	UINT	3Ph RMS Mains Voltage	3 Phase RMS Mains voltage reading (in volts) (L2-L3)
3 (0x03)	V	Get	UINT	3Ph RMS Mains Voltage	3 Phase RMS Mains voltage reading (in volts) (L3-L1)
4 (0x04)	V	Get	UINT	Line Frequency	Frequency reading of incoming mains voltage (in 0.01Hz)
5 (0x05)	V	Get	USINT	Incoming Phase Sequence	Phase sequence of incoming mains voltage 0 - ABC 1 - ACB
6 (0x06)	V	Get	UINT	DC Control Voltage	DC Control Voltage reading in 0.001V
7 (0x07)	NV	Set/Get	UINT	Motor Rated Volts	Rated voltage of the motor
8 (0x08)	NV	Set/Get	USINT	Under Voltage Trip Enable	Under voltage trip enable 0x00 - disable 0x01 - fault enable 0x02 - warning enable
9 (0x09)	NV	Set/Get	USINT	Under Voltage Trip Threshold	Under voltage trip threshold (in percent of rated motor voltage)
10 (0x0A)	NV	Set/Get	UINT	Under Voltage Trip Duration	Amount of time an under voltage condition must exist before a trip; 0.0 - 60.0 (in 0.1secs)
11 (0x0B)	NV	Set/Get	USINT	Over Voltage Trip Enable	Over voltage trip enable 0x00 - disable 0x01 - fault enable 0x02 - warning enable
12 (0x0C)	NV	Set/Get	USINT	Over Voltage Trip Threshold	Over voltage trip threshold (in percent of rated motor voltage)
13 (0x0D)	NV	Set/Get	UINT	Over Voltage Trip Duration	Amount of time an over voltage condition must exist before a trip; 0.0 - 60.0 (in 0.1secs)
14 (0x0E)	NV	Set/Get	USINT	Voltage Imbalance Trip Level	Voltage imbalance trip threshold
15 (0x0F)	NV	Set/Get	UINT	Voltage Imbalance Trip Duration	Amount of time a voltage imbalance condition must exist before a trip; 0.0 - 60.0 (in 0.1secs)
16 (0x10)	NV	Set/Get	UINT	Incoming Line Frequency Rating	Expected frequency of incoming mains voltage
17 (0x11)	NV	Set/Get	USINT	Line Frequency Trip	Line frequency deviation trip enable 0x00 - disable 0x01 - fault enable 0x02 - warning enable
18 (0x12)	NV	Set/Get	USINT	Frequency Deviation Trip Threshold	Line frequency deviation trip threshold (in percent of rated line frequency)
19 (0x13)	NV	Set/Get	UINT	Frequency Trip Duration	Amount of time a frequency deviation condition must exist before a trip; 0.0 - 60.0 (in 0.1secs)
20 (0x14)	NV	Set/Get	USINT	Phase Reversal Trip Enable	Phase reversal trip enable 0x00 - disable 0x01 - fault enable 0x02 - warning enable

### 6.6 EtherNet/IP Object Model Stand Alone I/O

When the Ethernet module is not connected to a host device such as the C440, the presented object model is compliant with the ODVA Discrete I/O device profile (type: 0x7).

#### Full Profile for Stand Alone Operation

The table below shows the supported classes of the Ethernet Module when connected to an S611 soft starter.

Class	Object	# of Instances	Description
0x01 (hex)	Identity	1	Provides module identity object: See details below.
0x02	Message Router	1	Internal object implemented per ODVA specification
0x04	Assembly Object	6	Binds attributes from multiple objects for access with a single Implicit (I/O) connection. See details below.
0x06	Connection Manager	1	Internal object supporting connection management. Implemented per ODVA specification
0x08	Discrete Input Point	4	Status information for the discrete Inputs. See details in previous section.
0x09	Discrete Output Point	2	Status and control for the discrete Outputs. See details in previous section.
0xF5	TCP/IP Interface	1	Information about the TCP/IP Interface. Implemented per ODVA specification
0xF6	Ethernet Link	2	Ethernet link object for each of the 2 Ethernet ports on the device. Implemented per ODVA specification.

#### Object Details

##### Class 1 (0x01): Identity Object

Instance Count: 1  
Instance List: 1

**Table 89. Stand Alone Identity Object Instant Attributes**

Attrib	NV	Access	Data Type	Name	Description
1	V	Get	UINT	CIP Vendor ID	ODVA Assigned Vendor Identification Number.
2	V	Get	UINT	CIP Device Type	CIP Defined General Product Type.
3	V	Get	UINT	Product Code	Vendor Product Code
4	V	Get	UINT	Firmware Rev	Com Adapter Firmware Rev.

**Table 89. Stand Alone Identity Object Instant Attributes (Cont.)**

Attrib	NV	Access	Data Type	Name	Description
5	V	Get	WORD	Device Status	This attribute represents the current status of the entire devices. Its value changes as the state of the device changes. Bit = Definition 0 = Owned. True indicates the device has an owner. 2 = Configured. True indicates the application of the device has been configured to do something different than out of box default. Does not include communication configuration. 4-7 = Extended Device Status. 8 = Minor Recoverable Fault. True indicates the device detected a problem with itself, which is thought to be recoverable. 9 = Minor Unrecoverable Fault. True indicates the device detected a problem with itself, which is thought to be unrecoverable. 10 = Major Recoverable Fault. True indicates the device detected a problem with itself causing a "Major Recoverable Fault" state. 11 = Major Unrecoverable Fault. True indicates the device detected a problem with itself causing a "Major Unrecoverable Fault" state.
6	NV	Set/Get	UDINT	Serial Number	32 bit Com Adapter Device Serial Number.
7	V	Get	SHORT_STRING	Product Name	ASCII Product Name.
8	V	Get	USINT	Device State	Present State of the Device. Value = Definition 0 = Nonexistent 1 = Device Self Testing 2 = Standby 3 = Operational 4 = Major Recoverable Fault 5 = Major Unrecoverable Fault 255 = Default for Get Attributes All.
176	NV	Set/Get	SHORT_STRING	Assigned Name	User Defined ASCII Name.

#### Class 4 (0x04): Assembly Object

Instance Count: 3  
Instance List: 3, 32, 107

**Table 90. Stand Alone Assembly Object Instance Attributes**

Attrib	NV	Access	Data Type	Name	Description
3	V	Set/Get	Array of BYTE	Data	Assembly Data. See sections below for instance definition.

**Table 91. Stand Alone Assembly Instance List:**

Type	Instance	Usage	Name
Input	3	Poll	Field Inputs
Output	32	Poll	Field Relay Outputs
Input	107	Poll	4In/2Out Assembly



Assembly Instance Definitions:

**Table 92. Stand Alone Assembly Instance 3 (0x03): Field Inputs**

Byte Offset	Word Offset	Size (bytes)	Name	Description
0	0	1	Field Inputs	A Bitfield Representing the Input Points. Bit = Description 0 = Input 1 1 = Input 2 2 = Input 3 3 = Input 4

Total Assembly Size (bytes): 1

**Table 93. Stand Alone Assembly Instance 32 (0x20): Field Relay Outputs**

Byte Offset	Word Offset	Size (bytes)	Name	Description
0	0	1	Field Relay Outputs	A Bitfield Representing the Output Points. Bit = Description 0 = Output 1 1 = Output 2 Total Assembly Size (bytes): 1

**Table 94. Stand Alone Assembly Instance 107 (0x6B): 4In/2Out Assembly**

Byte Offset	Word Offset	Size (bytes)	Name	Description
0	0	1	4In/2Out Assembly	4 input and 2 output single value. Bit = Description 2 = Relay 1 3 = Relay 2 4 = Input 1 5 = Input 2 6 = Input 3 7 = Input 4

Total Assembly Size (bytes): 1

Class 8 (0x08): Discrete Input Object

Instance Count: 4  
Instance List: 1, 2, 3, 4

**Table 95. Stand Alone Discrete Input Object Instance Attributes**

Attrib	NV	Access	Data Type	Name	Description
3		Get	BOOL	Input	0 = Off 1 = On
101	NV	Set/Get	UDINT	Field Inputs Debounce	The debounce applies to both rising and falling edge. (milliseconds)

Class 9 (0x09): Discrete Output Object

Instance Count: 2  
Instance List: 1, 2

**Table 96. Stand Alone Discrete Output Object Instance Attributes**

Attrib	NV	Access	Data Type	Name	Description
3	V	Set/Get	BOOL	Field Relay Outputs	Output point value Val = Description 0 = Off 1 = On
5	NV	Set/Get	BOOL	Field Relay Fault Action	When a communication fault occurs the output can execute two types of behavior. Value = Description 0 = Apply Fault Value 1 = No Change
6	NV	Set/Get	BOOL	Field Relay Fault State	Communication fault value to be applied. Value = Description 0 = Turn Relay Off 1 = Turn Relay On
7	NV	Set/Get	BOOL	Field Relay Idle Action	When a communication idle state occurs the relays can execute two types of behavior. Value = Description 0 = Apply Idle Value 1 = No Change
8	NV	Set/Get	BOOL	Field Relay Idle State	Communication idle value to be applied. Value = Description 0 = Turn Relay Off 1 = Turn Relay On

Class 153 (0x99): Test Only

Instance Count: 1  
Instance List: 1

**Table 97. Test Only**

Attrib	NV	Access	Data Type	Name	Description
147	NV	Set/Get	UINT	EtherNet/IP Comm Timeout	Range: 0–60,000 ms Default: 3000 ms

Class 245 (0xF5): TCP/IP Object

Instance Count: 1  
Instance List: 1

**Table 98. TCP/IP Object**

Attrib	NV	Access	Data Type	Name	Description
13	NV	Set/Get	UINT	Encapsulation Inactivity Timeout	Number of seconds of inactivity before TCP connection is closed

## 7 Modbus TCP and Modbus Serial Protocol Support

All versions of the Ethernet module (C441R, C441T, C441U and C441V) support the Ethernet based Modbus TCP protocol as a server device. The C441R and C441T modules provide a serial port that supports a serial Modbus RTU slave protocol as an additional monitoring port. The C441U and C441V stand alone modules also have this serial port, but it is required to be used as a host connection if used with the C440, S611, or S811+. If the C441R or C441T is used as a stand alone I/O block, the serial port is also available as an additional monitoring port.

The supported function codes and register maps are identical for both the Ethernet Modbus TCP and serial Modbus RTU protocols.

### 7.1 Supported Function Codes

Commands Supported	Function Codes
	0x01 Read Coils
	0x02 Read Discrete Inputs
	0x03 Read Holding Registers
	0x04 Read Input Register
	0x05 Write Single Coil
	0x06 Write Single Register
	0x0F Write Multiple Coils (15)
	0x10 Write Multiple Registers (16)
	0x17 Read/Write Multiple Registers (23)
	0x2B/0x0E Read Device Identification Get Device Identity (43/14) (see below for detail)

#### Function Code Details

##### 0x2B / 0x0E Read Device Identification / Get Device Identification

Device ID Codes 1,2 and 4 are implemented.  
Device ID code 3 (extended info) is not implemented

##### Object IDs

Object ID	Description
0	VendorName
1	ProductCode
2	MajorMinorRefision
3	VendorURL
4	ProductName
5	ModelName
6	UserApplicationName

## 7.2 Register Definitions for the C441 Motor Insight

Table 99. Registers Available with C441 Motor Insight

Start Coil	Register	Read/Write	Name	Description (Units)
1	1	R	Field Inputs	A Bitfield Representing the Input Points. Bit = Description 0 = Input 1 1 = Input 2 2 = Input 3 3 = Input 4
-	2	R	Control Voltage	Adapter Source Voltage. ( mV )
-	3	R	Ambient Temperature	Device ambient temperature as measured from the PCB. ( °C )
-	4	R/W	Max Board Temperature	The maximum board temperature experienced since manufacturing. ( °C )
65	5	R	Dip Switch Value	A bit field representing the present state of the dip switches.
-	6	R	Configuration CRC	A CRC value calculated over the non-volatile data present.
-	7	R/W	Serial Number	32 bit Com Adapter Device Serial Number.
-	9	R	Firmware Rev	Com Adapter Firmware Rev.
-	11	R/W	Hardware Rev	Com Adapter Hardware Rev.
1601	101	R/W	Field Relay Outputs	A Bitfield Representing the Output Points. Bit = Description 0 = Output 1 1 = Output 2
-	102	R/W	Field Inputs Debounce	Array of Debounce Values. A debounce value exists for each input. The debounce applies to both rising and falling edge. ( milliseconds )
-	110	R/W	Modbus TCP Com Timeout	Communication Timeout for Modbus TCP. 0 = Disable. ( milliseconds )
1761	111	R/W	Field Relay Fault Action	When a communication fault occurs the relays can execute two types of behavior. The behavior is selected on a per bit basis. Bit = Description 0 = Relay 1 1 = Relay 2  Bit Value = Description 0 = Apply Fault Value 1 = No Change
1777	112	R/W	Field Relay Fault State	Communication fault value to be applied. A bitfield where each bit defines an output point. Bit Value = Description 0 = Turn Relay Off 1 = Turn Relay On
1793	113	R/W	Field Relay Idle Action	When a communication idle state occurs the relays can execute two types of behavior. The behavior is selected on a per bit basis. Bit = Description 0 = Relay 1 1 = Relay 2  Bit Value = Description 0 = Apply Idle Value 1 = No Change
1809	114	R/W	Field Relay Idle State	Communication idle value to be applied. A bitfield where each bit defines an output point. Bit Value = Description 0 = Turn Relay Off 1 = Turn Relay On

**Table 99. Registers Available with C441 Motor Insight (Cont.)**

Start Coil	Register	Read/Write	Name	Description (Units)
-	143	R	Method of IP Allocation	The Method Used to Allocate an IP Address: 0 - DHCP 1 - Upper three octets from NV and lower octet selected by the dip switch setting. 2 - Full address taken from NV Memory. 3 - Restore (hardcoded 192.168.1.254).
-	144	R	Present Ethernet IP Address	The active IP address being used on the network.
-	146	R	Present Ethernet Subnet Mask	The active subnet mask IP address being used on the network.
-	148	R	Present Ethernet Default Gateway	The active default gateway IP address being used on the network.
-	150	R/W	Stored Ethernet IP Address	The IP address used in the NV address select configuration.
-	152	R/W	Stored Ethernet Subnet Mask	The IP subnet mask used in the NV address select configuration.
-	154	R/W	Stored Ethernet Default Gateway	The IP default gateway used in the NV address select configuration.
-	156	R/W	Ethernet MAC Address	-
-	159	R/W	Modbus Com Timeout	Communication Timeout for Modbus. 0 = Disable. ( milliseconds )
-	160	R/W	Modbus TX mode	Selects the Modbus Mode. 0 - RTU 1 - ASCII
-	161	R/W	Modbus Baud Rate	Selects the Modbus Baud Rate. 0 - 19.2kb 1 - 9.6kb 2 - 57.6kb 3 - 115.2kb
-	162	R/W	Modbus Address	Modbus Address Loaded at Startup.
-	163	R/W	Modbus Parity and Stop Bits	Selects the Modbus UART Parity and Stop Bits. 0 - Even/One Stop Bit 1 - Odd/One Stop Bit 2 - None/Two Stop Bits 3 - Even/Two Stop Bits 4 - Odd/Two Stop Bits 5 - None/One Stop Bit
3201	201	R	Intercom Status	Present State of the Intercom Link. Bit - Status 0 - Connected fully. No error messages. 1 - A message fault occurred. 2 - Devices are married. Target is identified and correct. 3 - A basic connection is established.
4001	251	R/W	Motor Ctrl Idle Loss Act Disable	When this value is TRUE the motor state will be unchanged after a communication idle event. A FALSE value will cause the Motor Control Communication Idle Value to be applied on a com idle event.
4017	252	R/W	Motor Ctrl Com Idle Action Val	Action to execute when a communication loss event occurs. 0 = Ignore (No Change) 1 = Stop
4033	253	R/W	Motor Ctrl Com Loss Act Disable	When this value is TRUE the motor state will be unchanged after a communication loss event. A FALSE value will cause the Motor Control Communication Loss Value to be applied on a com loss.

**Table 99. Registers Available with C441 Motor Insight (Cont.)**

Start Coil	Register	Read/Write	Name	Description (Units)
4049	254	R/W	Motor Ctrl Com Loss Action Val	Action to execute when a communication loss event occurs. 0 = Ignore (No Change) 1 = Stop
-	255	R/W	EtherNet/IP Comm Timeout	EtherNet/IP communication timeout Range: 0–60,000 ms Default: 3000 ms
-	256	R/W	Encapsulation Inactivity Timeout	Number of seconds of inactivity before TCP connection is closed
-	300	R	Current I1	Phase A RMS Current, Unit: 90 Amp Models: x0.1A 9 Amp Models: x0.1A when external CTs are used; x0.01A otherwise ( scale )
-	301	R	Current I2	Phase B RMS Current, Unit: 90 Amp Models: x0.1A 9 Amp Models: x0.1A when external CTs are used; x0.01A otherwise ( scale )
-	302	R	Current I3	Phase C RMS Current, Unit: 90 Amp Models: x0.1A 9 Amp Models: x0.1A when external CTs are used; x0.01A otherwise ( scale )
-	303	R	Current Average	Average RMS Current, Unit: 90 Amp Models: x0.1A 9 Amp Models: x0.1A when external CTs are used; x0.01A otherwise ( scale )
-	304	R	Voltage L1-L2	Phase A RMS Voltage L1-L2 ( V )
-	305	R	Voltage L2-L3	Phase B RMS Voltage L2-L3 ( V )
-	306	R	Voltage L3-L1	Phase C RMS Voltage L3-L1 ( V )
-	307	R	Voltage Average	Average RMS Voltage ( V )
-	308	R	Motor Power	Motor Power x0.1kW when external CTs are used x0.01kW otherwise ( scale )
-	309	R	Voltage Unbalance Percentage	Max deviation from average voltage divided by average voltage ( % )
-	310	R	Current Unbalance Percentage	Max deviation from average current divided by average current ( % )
-	311	R	Apparent Power Factor	cos(phi), (real power)/(apparent power) ( % )
-	312	R	Residual Ground Current	Residual Ground Current in Amps x 100 ( x0.01A )
-	313	R	Line frequency	Line Frequency ( x0.01Hz )
-	314	R	Thermal Pile Percentage	Thermal Capacity 0% Cold Motor 100% Will Cause and Overload Trip ( % )
-	315	R	Fault Queue	Fault Code and Fault Code List. When read as a single item it is the most recent fault. When read as a list, faults are listed in history order. Newest are at the beginning, oldest are at the end of the list. If the device is in the Faulted state, Fault Code indicates the fault that caused the transition to Faulted state. If not in the Faulted state, the Fault Code indicates the fault that caused the last transition to the Faulted state.
-	325	R	Remaining Rapid Cycling Restart Delay	Supply Fault - Time to Restart ( sec )
-	326	R	Remaining Normal Restart Delay	Motor Fault - Time to Restart ( sec )

**Table 99. Registers Available with C441 Motor Insight (Cont.)**

Start Coil	Register	Read/Write	Name	Description (Units)
-	327	R	Remaining Underload Trip Restart Delay	Load Fault - Time to Restart ( sec )
-	328	R/W	Run Time Hours	Motor Run Time in hours (resettable) ( hr )
-	329	R	Start Count	Start Count (Resettable)
-	330	R	Trip Reason	0x0001 - Restart Attempts Exceeded 0x0002 - Relay Turned Off (Network/UI) 0x0004 - Contactor Failure 0x0008 - Under Current Trip 0x0010 - Overload Trip 0x0020 - GND Fault Trip 0x0040 - Current Unbalance Trip 0x0080 - Current Single Phase 0x0100 - Reserved (0) 0x0200 - High Power Trip 0x0400 - Over Voltage Trip 0x0800 - Under Voltage Trip 0x1000 - Voltage Unbalance Trip 0x2000 - Over Current Trip 0x4000 - Low Power Trip 0x8000 - Phase Reversal Trip
-	331	R	Overload Status	Overload Status - 0x0001: Overload Trip - 0x0002: Ground Fault Trip - 0x0004: High Power Trip - 0x0080: Relay Closed
-	332	R	Error Code	Warning/Alarm Indications 0x0001 (1) - Low Voltage Warning 0x0002 (2) - High Voltage Warning 0x0004 (4) - Voltage Unbalance Warning 0x0008 (8) - Low Power Warning 0x0010 (16) - Reverse Phase Warning 0x0020 (32) - Current Unbalance Warning 0x0040 (64) - Voltage Single Phase Warning 0x0080 (128) - Current Single Phase Warning 0x0100 (256) - GND Fault Warning
-	333	R	C441 DSP FW Version	C441 DSP Firmware Version
-	334	R	UI Firmware Version	User Interface Firmware Version
-	335	R/W	C441 Unit ID	Unit ID 0x00BA (186) - C441BA 0x00BB (187) - C441BB 0x00CA (202) - C441CA 0x00CB (203) - C441CB 0x00DA (218) - C441DA 0x00DB (219) - C441DB 0x00EA (234) - C4410109(x) 0x00EB (235) - C4410590(x)
5361	336	R	Aux Relay Trip Reason	0x0002 - Relay Turned Off (Network/UI) 0x0004 - Contactor Failure 0x0008 - Under Current Trip 0x0010 - Overload Trip 0x0020 - GND Fault Trip 0x0040 - Current Unbalance Trip 0x0080 - Current Single Phase 0x0100 - Mains Freq Fault 0x0200 - High Power Trip 0x0400 - Over Voltage Trip 0x0800 - Under Voltage Trip 0x1000 - Voltage Unbalance Trip 0x2000 - Over Current Trip 0x4000 - Low Power Trip 0x8000 - Phase Reversal Trip

**Table 99. Registers Available with C441 Motor Insight (Cont.)**

Start Coil	Register	Read/Write	Name	Description (Units)
-	400	R/W	Command register	0x0066 - Clear Motor Run Hours 0x0077 - Clear Fault Queue 1 0x0078 - Clear Fault Queue 0x0088 - Network watchdog enable 0x0099 - Network watchdog disable 0x00AA - Reset Relay 0x00BB - Clear Motor Start Count 0x00CC - Force Ground Fault 0x00DD - Fault Relay OFF 0x00EE - Reset Auxiliary Relay (120 Vac Control Power models only)
-	401	R/W	Motor Control	-
-	402	R/W	Configuration Reset	1 = Soft Reset (equivalent to a power cycle) 2 = Factory Reset
-	403	R/W	CT Multiplier	For 90 Amp Units: 1-4, number of conductors through CT. For 9 Amp Units: 1-2, number of conductors through CT; For 9 Amp Units, CT multipliers: 3 (150:5), 4 (300:5), 5 (600:5)
-	404	R/W	Ground Fault Pick-up Level	Ground Fault Pick-up Level ( x0.01A )
-	405	R/W	Under Current Pick-up Level	Under Current Pick-up Level ( % )
-	406	R/W	Low Power Pick-up Level	Low Power Pick-up Level ( x0.01kW )
-	407	R/W	Overload FLA	Motor Full Load Current ( x0.01A )
-	408	R/W	Current Unbalance Pick-up Level	Current Unbalance Pick-up Level ( % )
-	409	R/W	Overload Trip Class	Overload Trip Class
-	410	R/W	Under Voltage Pick-up Level	Under Voltage Pick-up Level ( V )
-	411	R/W	Over Voltage Pick-up Level	Over Voltage Pick-up Level ( V )
-	412	R/W	Voltage Unbalance Pick-up Level	Voltage Unbalance Pick-up Level ( % )
-	413	R/W	Jam Pick-up Level	Jam Pick-up Level ( % )
-	414	R/W	High KW Trip limit	High Power Pick-up Level ( x0.01kW )
-	415	R/W	Phase Order	Phase Order - 0 (Trip Disabled) - 1 ACB - 2 ABC
-	416	R/W	Supply Fault Hold-off Time	Restart Delay ( sec )
-	417	R/W	Motor Fault Hold-off Time	Motor Fault Reset Delay ( min )
-	418	R/W	Load Fault Hold-off Time	Load Fault Reset Delay ( min )
-	419	R/W	Load Fault Number of Restarts	Load Fault Number of Reset Attempts 0: Manual 1-4 5: Automatic
-	420	R/W	Motor Fault Number of Restarts	Motor Fault Number of Attempts: 0: Manual 1-4 5: Automatic
-	421	R/W	Ground Fault Trip Delay	Ground Fault Pickup Delay ( sec )
-	422	R/W	Under Current Trip Delay	Under Current Trip Delay ( sec )
-	423	R/W	Low Power Trip Delay	Low Power Trip Delay ( sec )
-	424	R/W	Jam Trip Delay	Jam Trip Delay ( sec )

**Table 99. Registers Available with C441 Motor Insight (Cont.)**

Start Coil	Register	Read/Write	Name	Description (Units)
-	425	R/W	Current Unbalance Trip Delay	Current Unbalance Trip Delay ( sec )
-	426	R/W	Under Voltage Trip Delay	Under Voltage Trip Delay ( sec )
-	427	R/W	Over Voltage Trip Delay	Over Voltage Trip Delay ( sec )
-	428	R/W	Voltage Unbalance Trip Delay	Voltage Unbalance Run Delay ( sec )
-	429	R/W	High KW Trip Time	High Power Trip Delay ( sec )
-	430	R/W	Current Phase Loss Trip Delay	Pickup delay for current phase loss ( sec )
-	433	R/W	Enable/Disable Trip	Trip Enable/Disable Bit Array: 0x0001 (1): Enable Ground Fault 0x0002 (2): Enable Voltage Unbalance 0x0004 (4): Enable Current Unbalance 0x0008 (8): Enable Under Current 0x0010 (16): Enable Phase Loss 0x0020 (32): Enable Jam 0x0040 (64): Enable Low Power 0x0080 (128): Enable High Power 0x0100 (256): Enable Over Voltage 0x0200 (512): Enable Under Voltage 0x0400 (1024): Enable Phase Order
-	434	R/W	Overload Reset	Overload Reset Mode 0: manual reset 1: apply Motor Fault Reset Delay and Number of Attempts
-	435	R/W	Voltage Faults Trip Mode	Voltage Faults Trip Mode 0 - Trip on Supply Fault 1: Alarm-no-trip (inhibit start)
-	436	R/W	Ground Fault Trip Mode	Ground Fault Trip Mode 0 - Trip on ground fault 1 - Alarm no trip
-	437	R/W	Run Transition Percent	Run Transition % of FLA ( % )
-	438	R/W	Run Transition Time	Run Transition Time ( sec )
-	439	R	Network Status	Network Status 0x0001: Watchdog Enabled 0x0004: Front Panel Locked
-	440	R/W	C441 Comm loss Timeout	Communication Loss Timeout ( millisec )
-	441	R/W	C441 Comm loss behavior	1 = Fault - Default 2 = Hold Last State
-	443	R/W	Load Fault Reset Delay Calc	Load Fault Reset Delay Calculator Enable. Value = Description 0 = Disable (default) 1 = Enabled
7089	444	R/W	Aux Relay Config Byte 1	Only Available for 120 V Control Power Models. Each bit of this configuration parameter enables (value 1) or disables (value 0) a fault for the auxiliary relay. The meanings of the bits are: 0x01: Ground Fault 0x02: Voltage Unbalance 0x04: Current Unbalance 0x08: Under Current 0x10: Phase Loss 0x20: Jam

**Table 99. Registers Available with C441 Motor Insight (Cont.)**

Start Coil	Register	Read/Write	Name	Description (Units)
7105	445	R/W	Aux Relay Config Byte 2	Only Available for 120 V Control Power Models. Each bit of this configuration parameter enables (value 1) or disables (value 0) a fault for the auxiliary relay. The meanings of the bits are: 0x01: Low Power 0x02: High Power 0x04: Over Voltage 0x08: Under Voltage 0x10: Phase Order 0x20: Overload 0x40: Supply Frequency Fault
-	446	R/W	Aux Reset Delay	Only Available for 120V Control Power Models. 0: Automatic reset of the auxiliary relay disabled 1 - 500: automatic auxiliary relay reset delay since last auxiliary relay fault ( min )
-	447	R/W	Wire Config	0 = Three-phase 1 = Single-phase voltage and current 2 = Three-phase current only
-	448	R/W	Overload on start enable	0 = Disabled 1 = Enabled
-	449	R/W	GF on start enable	0 = Disabled 1 = Enabled
-	450	R/W	Anti-backspin time	A fault will be generated after every motor stop. No resets will be permitted during the backspin period. Range: 0 to 3600 seconds
-	451	R/W	PT Ratio	Indicates a PT ratio: 120 step-down Range = 0 to 8000, (0) zero indicates no PT connected
-	1000	R/W	Modbus Production List	The Production and consumption Registers can be used to create custom Modbus interface ranges. An example: If field inputs register address 0 is put into the first slot of the production list, the field inputs register value will be available in the first slot of the Modbus Production Data Register range. Production data is data provided by the device and Consumption data is for data provided (written) to the device. Note that the values must be Modbus Register Address (i.e., Register Number - 1) not Register Number.
-	2000	R	Modbus Production Data	-
-	3000	R/W	Modbus Consumption List	The Production and consumption Registers can be used to create custom Modbus interface ranges. An example: If field inputs register address 0 is put into the first slot of the production list, the field inputs register value will be available in the first slot of the Modbus Production Data Register range. Production data is data provided by the device and Consumption data is for data provided (written) to the device. Note that the values must be Modbus Register Address (i.e., Register Number - 1) not Register Number.
-	4000	R/W	Modbus Consumption Data	-

7.3 Register Definition for the C440 Overload Relay

Table 100. Registers for the C440 Overload Relay

Start Coil	Register	Read/Write	Name	Description (Units)
1	1	R	Field Inputs	A Bitfield Representing the Input Points. Bit = Description 0 = Input 1 1 = Input 2 2 = Input 3 3 = Input 4
-	2	R	Control Voltage	Adapter Source Voltage. ( mV )
-	3	R	Ambient Temperature	Device Ambient Temperature as Measured from the PCB. ( °C )
-	4	R/W	Max Board Temperature	The maximum board temperature experienced since manufacturing. ( °C )
65	5	R	Dip Switch Value	A bit field representing the present state of the dip switches.
-	6	R	Configuration CRC	A CRC value calculated over the non-volatile data present.
-	7	R/W	Serial Number	32 bit Com Adapter Device Serial Number.
-	9	R	Firmware Rev	Com Adapter Firmware Rev.
-	11	R/W	Hardware Rev	Com Adapter Hardware Rev.
1601	101	R/W	Field Relay Outputs	A Bitfield Representing the Output Points. Bit = Description 0 = Output 1 1 = Output 2
-	102	R/W	Field Inputs Debounce	Array of Debounce Values. A debounce value exists for each input. The debounce applies to both rising and falling edge. ( milliseconds )
-	110	R/W	Modbus TCP Com Timeout	Communication Timeout for Modbus TCP. 0 = Disable. ( milliseconds )
1761	111	R/W	Field Relay Fault Action	When a communication fault occurs the relays can execute two types of behavior. The behavior is selected on a per bit basis. Bit = Description 0 = Relay 1 1 = Relay 2  Bit Value = Description 0 = Apply Fault Value 1 = No Change
1777	112	R/W	Field Relay Fault State	Communication fault value to be applied. A bitfield where each bit defines an output point. Bit Value = Description 0 = Turn Relay Off 1 = Turn Relay On
1793	113	R/W	Field Relay Idle Action	When a communication idle state occurs the relays can execute two types of behavior. The behavior is selected on a per bit basis. Bit = Description 0 = Relay 1 1 = Relay 2  Bit Value = Description 0 = Apply Idle Value 1 = No Change
1809	114	R/W	Field Relay Idle State	Communication idle value to be applied. A bitfield where each bit defines an output point. Bit Value = Description 0 = Turn Relay Off 1 = Turn Relay On
-	143	R	Method of IP Allocation	The Method Used to Allocate an IP Address: 0 - DHCP 1 - Upper three octets from NV and lower octet selected by the dip switch setting. 2 - Full address taken from NV Memory. 3 - Restore (hardcoded 192.168.1.254).

Table 100. Registers for the C440 Overload Relay (Cont.)

Start Coil	Register	Read/Write	Name	Description (Units)
-	144	R	Present Ethernet IP Address	The active IP address being used on the network.
-	146	R	Present Ethernet Subnet Mask	The active subnet mask IP address being used on the network.
-	148	R	Present Ethernet Default Gateway	The active default gateway IP address being used on the network.
-	150	R/W	Stored Ethernet IP Address	The IP address used in the NV address select configuration.
-	152	R/W	Stored Ethernet Subnet Mask	The IP subnet mask used in the NV address select configuration.
-	154	R/W	Stored Ethernet Default Gateway	The IP default gateway used in the NV address select configuration.
-	156	R/W	Ethernet MAC Address	-
3201	201	R	Intercom Status	Present State of the Intercom Link. Bit - Status 0 - Connected fully. No error messages. 1 - A message fault occurred. 2 - Devices are married. Target is identified and correct. 3 - A basic connection is established.
4001	251	R/W	Motor Ctrl Idle Loss Act Disable	When this value is TRUE the motor state will be unchanged after a communication idle event. A FALSE value will cause the Motor Control Communication Idle Value to be applied on a com idle event.
4017	252	R/W	Motor Ctrl Com Idle Action Val	Action to execute when a communication loss event occurs. 0 = Ignore (No Change) 1 = Stop
4033	253	R/W	Motor Ctrl Com Loss Act Disable	When this value is TRUE the motor state will be unchanged after a communication loss event. A FALSE value will cause the Motor Control Communication Loss Value to be applied on a com loss.
4049	254	R/W	Motor Ctrl Com Loss Action Val	Action to execute when a communication loss event occurs. 0 = Ignore (No Change) 1 = Stop
-	255	R/W	EtherNet/IP Comm Timeout	EtherNet/IP communication timeout Range: 0–60,000 ms Default: 3000 ms
-	256	R/W	Encapsulation Inactivity Timeout	Number of seconds of inactivity before TCP connection is closed
-	300	R	Motor Ctrl State	Motor Control States: 0 = Stopped 1 = Running 2,3 = Tripped 4 = Resetting
-	301	R	Scaled Current Phase A RMS	Scaled RMS Current Phase A ( Amps )
-	302	R	Scaled Current Phase B RMS	Scaled RMS Current Phase B ( Amps )
-	303	R	Scaled Current Phase C RMS	Scaled RMS Current Phase C ( Amps )
-	304	R	Scaled 3Phase Ave Current	Average of the 3 Scaled RMS Currents ( Amps )
-	305	R	Thermal Memory Percentage	Present Thermal Value. 100% equates to a trip condition. ( % )

**Table 100. Registers for the C440 Overload Relay (Cont.)**

Start Coil	Register	Read/Write	Name	Description (Units)
-	306	R	Latched Faults	Faults are cleared when the device is either reset by the network or detects current flowing. The fault bits are defined as follows: Bit Feature 0 Overload Fault 1 Phase Imbalance 2 Phase Loss Fault 3 Ground Fault 4 Network Trip Command 5 NV Memory Failure 6-> Reserved
-	307	R	Current as Percentage of FLA	Current as a percentage of FLA. Ie: If Current is 1Amp and the FLA is 1AMP the percent would be 100%. ( % )
-	308	R	Phase Imbalance Percent	Percent of Measured Phase Imbalance ( % )
-	309	R	Ground Fault Percent	Percent of Ground Fault Measured. GF% = GFC / ((.5)*FLA) ( % )
-	310	R	Scaled Ground Current RMS	Scaled Ground Current. ( Amps )
-	311	R	Scaled FLA Setting	The present FLA setting. The potentiometer selects this value. The value is scaled by the multiplier. ( Amps )
-	312	R	Overload Class	The present FLA class. Class settings are device dependent.
-	313	R	Line Frequency	The line frequency measured by the device. The frequency is displayed in deciHz. ( Hertz )
-	314	R	Feature States	The feature status bits are defined as follows: Bit Feature 01 Class Index (00 = Class 10; 01 = Class 15; 10 = Class 20; 11 = Class 30) 2 Phase Loss/Imbalance Enabled 3 Ground Fault Enabled 4 Auto Reset Enabled 5 Remote Reset Active 6 Dip Switch Position 0 7 Dip Switch Position 1 8 Dip Switch Position 2 9 Dip Switch Position 3 10-15 Reserved
-	315	R	Device Temperature	The temperature as seen by the micro-controller. Accuracy ~ 10%. ( °C )
-	332	R/W	Trip/Reset Control	When a state change is requested the bit will remain active until the device is able to execute the command. The bits are auto clearing after the state has been changed. Any other bits will simply be cleared. The following bits are defined: Bit Action 0 Cause a Trip (will override a reset). 1 Cause a Reset
-	396	R	Scaled Min FLA	This is the min FLA setting possible in this device. The value is scaled by the multiplier. ( Amps )
-	397	R	Scaled Max FLA	This is the max FLA setting possible in this device. The value is scaled by the multiplier. ( Amps )
-	398	R	Current Scale Value	This value indicates the multiplier applied to the current values. For example: If the multiplier is 10 then all currents are read out in deciamps. 1A => 10A. ( Scale )
-	399	R	Product Code	The product code defines the internal Eaton product code. If the number is odd - it is Ground Fault Capable.
-	400	R	Serial Number	32 bit Vendor Specific Serial Number.
-	402	R	Hardware Rev	Hardware revision is stored as a 2byte number with a major and minor revision.

**Table 100. Registers for the C440 Overload Relay (Cont.)**

Start Coil	Register	Read/Write	Name	Description (Units)
-	428	R	Firmware Revision	The firmware revision is stored in 32bit format. 0xMMmmbbbb. Where M = Major Revision, m = Minor Revision and b = Build Number.
-	429	R	Firmware Build	The firmware build is a 16 bit number. 0xbbbb - b = Build Number.
-	430	R	Firmware Checksum	The 32 bit checksum of the code. A simple 16 bit addition checksum.
-	1000	R/W	Modbus Production List	The Production and consumption Registers can be used to create custom Modbus interface ranges. An example: If field inputs register address 0 is put into the first slot of the production list, the field inputs register value will be available in the first slot of the Modbus Production Data Register range. Production data is data provided by the device and Consumption data is for data provided (written) to the device. Note that the values must be Modbus Register Address (i.e., Register Number - 1) not Register Number.
-	2000	R	Modbus Production Data	-
-	3000	R/W	Modbus Consumption List	The Production and consumption Registers can be used to create custom Modbus interface ranges. An example: If field inputs register address 0 is put into the first slot of the production list, the field inputs register value will be available in the first slot of the Modbus Production Data Register range. Production data is data provided by the device and Consumption data is for data provided (written) to the device. Note that the values must be Modbus Register Address (i.e., Register Number - 1) not Register Number.
-	4000	R/W	Modbus Consumption Data	-

7.4 Register Definition for the S611 Soft Starter

Table 101. Register Definition for the S611 Soft Starter

Start Coil	Register	Read/Write	Name	Description (Units)
1	1	R	Field Inputs	A Bitfield Representing the Input Points. Bit = Description 0 = Input 1 1 = Input 2 2 = Input 3 3 = Input 4
-	2	R	Control Voltage	Adapter Source Voltage. ( mV )
-	3	R	Ambient Temperature	Device ambient temperature as measured from the PCB. ( °C )
-	4	R/W	Max Board Temperature	The maximum board temperature experienced since manufacturing. ( °C )
65	5	R	Dip Switch Value	A bit field representing the present state of the dip switches.
-	6	R	Configuration CRC	A CRC value calculated over the non-volatile data present.
-	7	R/W	Serial Number	32 bit Com Adapter Device Serial Number.
-	9	R	Firmware Rev	Com Adapter Firmware Rev.
-	11	R/W	Hardware Rev	Com Adapter Hardware Rev.
1601	101	R/W	Field Relay Outputs	A Bitfield Representing the Output Points. Bit = Description 0 = Output 1 1 = Output 2
-	102	R/W	Field Inputs Debounce	Array of debounce values. A debounce value exists for each input. The debounce applies to both rising and falling edge. ( milliseconds )
-	110	R/W	Modbus TCP Com Timeout	Communication Timeout for Modbus TCP. 0 = Disable. ( milliseconds )
1761	111	R/W	Field Relay Fault Action	When a communication fault occurs the relays can execute two types of behavior. The behavior is selected on a per bit basis. Bit = Description 0 = Relay 1 1 = Relay 2  Bit Value = Description 0 = Apply Fault Value 1 = No Change
1777	112	R/W	Field Relay Fault State	Communication fault value to be applied. A bitfield where each bit defines an output point. Bit Value = Description 0 = Turn Relay Off 1 = Turn Relay On
1793	113	R/W	Field Relay Idle Action	When a communication idle state occurs the relays can execute two types of behavior. The behavior is selected on a per bit basis. Bit = Description 0 = Relay 1 1 = Relay 2  Bit Value = Description 0 = Apply Idle Value 1 = No Change
1809	114	R/W	Field Relay Idle State	Communication idle value to be applied. A bitfield where each bit defines an output point. Bit Value = Description 0 = Turn Relay Off 1 = Turn Relay On

Table 101. Register Definition for the S611 Soft Starter (Cont.)

Start Coil	Register	Read/Write	Name	Description (Units)
-	143	R	Method of IP Allocation	The Method Used to Allocate an IP Address: 0 - DHCP 1 - Upper three octets from NV and lower octet selected by the dip switch setting. 2 - Full address taken from NV Memory. 3 - Restore (hardcoded 192.168.1.254).
-	144	R	Present Ethernet IP Address	The active IP address being used on the network.
-	146	R	Present Ethernet Subnet Mask	The active subnet mask IP address being used on the network.
-	148	R	Present Ethernet Default Gateway	The active default gateway IP address being used on the network.
-	150	R/W	Stored Ethernet IP Address	The IP address used in the NV address select configuration.
-	152	R/W	Stored Ethernet Subnet Mask	The IP subnet mask used in the NV address select configuration.
-	154	R/W	Stored Ethernet Default Gateway	The IP default gateway used in the NV address select configuration.
-	156	R/W	Ethernet MAC Address	-
-	159	R/W	Modbus Com Timeout	Communication Timeout for Modbus. 0 = Disable. ( milliseconds )
-	160	R/W	Modbus TX mode	Selects the Modbus Mode. 0 - RTU 1 - ASCII
-	161	R/W	Modbus Baud Rate	Selects the Modbus Baud Rate. 0 - 19.2kb 1 - 9.6kb 2 - 57.6kb 3 - 115.2kb
-	162	R/W	Modbus Address	Modbus address loaded at startup.
-	163	R/W	Modbus Parity and Stop Bits	Selects the Modbus UART Parity and Stop Bits. 0 - Even/One Stop Bit 1 - Odd/One Stop Bit 2 - None/Two Stop Bits 3 - Even/Two Stop Bits 4 - Odd/Two Stop Bits 5 - None/One Stop Bit
3201	201	R	Intercom Status	Present State of the Intercom Link. Bit - Status 0 - Connected fully. No error messages. 1 - A message fault occurred. 2 - Devices are married. Target is identified and correct. 3 - A basic connection is established.
4001	251	R/W	Motor Ctrl Idle Loss Act Disable	When this value is TRUE the motor state will be unchanged after a communication idle event. A FALSE value will cause the Motor Control Communication Idle Value to be applied on a com idle event.
4017	252	R/W	Motor Ctrl Com Idle Action Val	Action to execute when a communication loss event occurs. 0 = Ignore (No Change) 1 = Stop
4033	253	R/W	Motor Ctrl Com Loss Act Disable	When this value is TRUE the motor state will be unchanged after a communication loss event. A FALSE value will cause the Motor Control Communication Loss Value to be applied on a com loss.
4049	254	R/W	Motor Ctrl Com Loss Action Val	Action to execute when a communication loss event occurs. 0 = Ignore (No Change) 1 = Stop



**Table 101. Register Definition for the S611 Soft Starter (Cont.)**

Start Coil	Register	Read/Write	Name	Description (Units)
-	255	R/W	EtherNet/IP Comm Timeout	EtherNet/IP communication timeout Range: 0–60,000 ms Default: 3000 ms
-	256	R/W	Encapsulation Inactivity Timeout	Number of seconds of inactivity before TCP connection is closed
-	300	R	Motor Status	Motor Control Status Bits: Bit = Description 0 = Run 2 = In Bypass 5 = Fault 11 = Relay 1 State 12 = Relay 2 State 13 = Control From Network 14 = Permissive State
-	301	R	Current Scale Factor	Scale Factor for Current. Use this value to scale the current values.
-	302	R	Phase A RMS Current	Scaled RMS Current of Phase A. (Amps)
-	303	R	Phase B RMS Current	Scaled RMS Current of Phase B. (Amps)
-	304	R	Phase C RMS Current	Scaled RMS Current of Phase C. (Amps)
-	305	R	Average Current	Average of the 3 Scaled RMS Currents. (Amps)
-	306	R	Vab RMS Voltage	RMS line-to-line voltage measured between phase A and B. (Volts)
-	307	R	Vbc RMS Voltage	RMS line-to-line voltage measured between phase B and C. (Volts)
-	308	R	Vca RMS Voltage	RMS line-to-line voltage measured between phase C and A. (Volts)
-	309	R	Average Voltage	Average of the 3 Scaled RMS Voltages (Volts)
-	310	R	Total Kilowatts	Scaled Total Kilowatts. Scale factor is x10 (kW)
-	311	R	Apparent Power Factor	Apparent Power Factor * 100
-	312	R	Power Sign	Indicates whether power is positive or negative. In the case of a generator.
-	313	R	Line Frequency	Scaled Line Frequency. Scaling is x100. (Hz)
-	314	R	Overload Thermal Memory	Thermal Capacity 0% Cold Motor 100% Will Cause an Overload Trip ( % )
-	315	R	Current Unbalance	Percent Current Phase Imbalance. ( % )
-	316	R	Voltage Unbalance	Voltage Unbalance Percent. ( % )
-	317	R	Residual Ground Fault Current	Scaled Residual Ground Fault Current. Scaling = x100
-	318	R	Phase A Pole Temp	Power Pole Temperature. Scaled = x10 ( °C )
-	319	R	Phase B Pole Temp	Power Pole Temperature. Scaled = x10 ( °C )
-	320	R	Phase C Pole Temp	Power Pole Temperature. Scaled = x10 ( °C )
-	321	R	Pole Temp	Average Power Pole Temperature. Scaled = x10 ( °C )
-	322	R	Number of Starts	Total number of starts can be reset through the command parameter.
-	323	R	Total Run Time	Run time in hours. Total run time can be reset through the command parameter. ( Hours )

**Table 101. Register Definition for the S611 Soft Starter (Cont.)**

Start Coil	Register	Read/Write	Name	Description (Units)
-	324	R	Trip Reason	Bit = Description 0 = Overload 1 = Jam 2 = Stall 3 = Current Imbalance 4 = Load Disconnect 5 = Phase Loss 6 = Mains Fault 7 = Phase Reversal 8 = Shorted SCR 9 = SCR Not Firing 10 = Pole Overtemp 11 = Bypass Dropout 12 = SCR Overcurrent 13 = Contactor Overcurrent 14 = Communication Fault 15 = Other Device Fault
-	325	R	Fault Code	Fault Code and Fault Code List. When read as a single item it is the most recent fault. When read as a list, faults are listed in history order. Newest are at the beginning, oldest are at the end of the list. If the device is in the Faulted state, Fault Code indicates the fault that caused the transition to Faulted state. If not in the Faulted state, the Fault Code indicates the fault that caused the last transition to the Faulted state.
-	335	R	Orion Firmware Revision	-
-	336	R	Orion Firmware Build	-
-	337	R	Orion UI Firmware	Firmware Version for the User Interface.
-	338	R	Unit ID	Descriptive Product Identifier.
-	399	R/W	Modbus Change Tracker Queue	-
-	400	R/W	Motor Control	Motor Control Bits: Bit = Description 0 = Run 2 = Permissive 3 = Reset
-	401	R/W	Start Input Behavior	Selects the behavior for the start input. When edge is selected, a start will only be performed on the rising edge of the start input. When level is selected, a start will occur any time the input is high. 0 = Edge 1 = Level
-	402	R/W	Command Register	1 = Clear Motor Run Hours 2 = Clear Motor Start Count 3 = Clear Fault Queue 255 = Force Overload Rest (TP = 0) 250 = Force Comm Fault (Unpublished)
-	403	R/W	Configuration Reset	1 = Soft Reset 2 = Factory Defaults
-	404	R/W	Scaled Overload FLA	Scaled Overload FLA. Scaling factor is x10. ( Amps )
-	405	R/W	Rated Voltage	Rated Voltage of the Motor.
-	406	R/W	Start Method	Motor Start Method: 0 = Vramp 1 = Limit 2 = Pump <b>Note:</b> If special function bit 0 is set, then pump option is available and set as the default, otherwise ramp start (0) is default
-	407	R/W	Start Time	Motor Start Ramp Time. ( deciseconds )
-	408	R/W	Initial Motor Torque	Starting (Initial) Torque Percent.

**Table 101. Register Definition for the S611 Soft Starter (Cont.)**

Start Coil	Register	Read/Write	Name	Description (Units)
-	409	R/W	Stop Time	Motor Stop Ramp Time. Minimum time of 0 without pump option. Minimum time of 50 with pump stop enabled ( deciseconds )
-	410	R/W	Pump Stop Time	If supported, the amount of time to use for the pump stop ramp behavior. ( seconds )
-	411	R/W	Kick Start Time	The Amount of Time to Apply a Kick Start. ( deciseconds )
-	412	R/W	Kick Start Initial Torque	Initial Torque Value for the Kick Start. ( % )
-	413	R/W	Reset Mode	Method of Reset. 0 = Manual 1 = Auto
-	414	R/W	Fault Enable Bits	Fault Enable Bits: Bit = Description 0 = Overload 1 = Jam 2 = Stall 3 = Current Imbalance 4 = Load Disconnect 5 = Phase Loss 6 = Under Voltage 7 = Over Voltage 8 = Voltage Unbalance 9 = Phase Reversal 10 = Ground Fault 11 = Overload On Start 12 = Shorted SCR 13 = SCR Not Firing 14 = Over Temperature
-	415	R/W	Overload Class	Overload Trip Class Setting.
-	416	R/W	Jam Trip Level	Jam Trip Level Set in Percent of FLA. ( % )
-	417	R/W	Jam Trip Delay	Jam Trip Delay in Seconds. ( seconds )
-	418	R/W	Stall Trip Level	Stall Trip Level in Percent of FLA. ( % )
-	419	R/W	Residual GF Trip Level	Scaled Residual Ground Fault Trip Level. Scaling = x100
-	420	R/W	Residual GF Trip Delay	Length of time that the ground fault must be present to cause a trip. ( seconds )
-	421	R/W	Residual GF Start Delay	Length of time before the device will begin to acknowledge the ground fault current. ( seconds )
-	422	R/W	Current Unbalance Trip Level	Unbalance level where a trip will be triggered. ( % )
-	423	R/W	Current Unbalance Trip Delay	Trip delay applied to the unbalance trip. ( Seconds )
-	424	R/W	Load Disconnect Trip Level	Load disconnect trip level as a percent of rated FLA. ( % )
-	425	R/W	Load Disconnect Trip Delay	Load disconnect trip delay in seconds. ( seconds )
-	426	R/W	Load Disconnect Source	Load Disconnect Source: 0 = Under Power 1 = Under Current
-	427	R/W	Phase Loss Trip Level	Trip Level for a Phase Imbalance Trip. ( % )
-	428	R/W	Phase Loss Trip Delay	Trip Delay applied to the Phase Loss Trip Sense. ( seconds )
-	429	R/W	Under Voltage Level	Percent Undervoltage Relative to Set Voltage. ( % )
-	430	R/W	Under Voltage Trip Delay	Delay Applied to the Undervoltage Trip. ( seconds )
-	431	R/W	Over Voltage Level	Overvoltage Percent Trip Level. ( % )

**Table 101. Register Definition for the S611 Soft Starter (Cont.)**

Start Coil	Register	Read/Write	Name	Description (Units)
-	432	R/W	Over Voltage Trip Delay	Overvoltage Trip Delay. ( seconds )
-	433	R/W	Voltage Unbalance Trip Level	Unbalance Level where a Trip will be Triggered. ( % )
-	434	R/W	Voltage Unbalance Trip Delay	Delay Applied to Voltage Unbalance Trip. ( seconds )
-	435	R/W	Phase Sequence	Line Voltage Phase Sequence: 1 = ABC 2 = ACB
-	436	R/W	Fault Relay Config	Fault Relay Configuration: 0 = Faulted 1 = Not Faulted
-	437	R/W	Auxiliary Relay Configuration	Auxiliary Relay Configuration Behavior: 0 = Faulted 1 = Not Faulted 2 = Bypass 3 = Not In Bypass 4 = Motor Energized 5 = Motor Not Energized
-	438	R/W	UI Edit Lock	Provides the ability to prevent the user interface from making configuration changes. 0 = Unlocked 1 = Locked
-	439	R/W	User Interface Display Config	User Interface Display Configuration. Value = Description 0 = Thermal Capacity 1 = Power Factor 2 = Line Frequency 3 = Current Unbal % 4 = Voltage Unbalance % 5 = Average pole temp 6 = Pole A Temp 7 = Pole B Temp 8 = Pole C Temp
-	443	R/W	Communication Loss Timeout	Communication Loss Timeout Value ( milliseconds )
-	444	R/W	Communication Loss Behavior	1 = Fault 2 = Hold last state 3 = Stop (1)
-	445	R/W	Network Timeout	Network Watchdog or Timeout Enable. 0 = Disable 1 = Enable
-	1000	R/W	Modbus Production List	The Production and consumption Registers can be used to create custom Modbus interface ranges. An example: If field inputs register address 0 is put into the first slot of the production list, the field inputs register value will be available in the first slot of the Modbus Production Data Register range. Production data is data provided by the device and Consumption data is for data provided (written) to the device. Note that the values must be Modbus Register Address (i.e., Register Number - 1) not Register Number.
-	2000	R	Modbus Production Data	-

**Table 101. Register Definition for the S611 Soft Starter (Cont.)**

Start Coil	Register	Read/Write	Name	Description (Units)
-	3000	R/W	Modbus Consumption List	The Production and consumption Registers can be used to create custom Modbus interface ranges. An example: If field inputs register address 0 is put into the first slot of the production list, the field inputs register value will be available in the first slot of the Modbus Production Data Register range. Production data is data provided by the device and Consumption data is for data provided (written) to the device. Note that the values must be Modbus Register Address (i.e., Register Number - 1) not Register Number.
-	4000	R/W	Modbus Consumption Data	-

**7.5 Register Definitions for S811+ Soft Starter**

**Table 102. Register Definitions for S811+ Soft Starter**

Start Coil	Register	Read/Write	Name	Description (Units)
1	1	R	Field Inputs	A bitfield representing the input points. Bit = Description 0 = Input 1 1 = Input 2 2 = Input 3 3 = Input 4
-	2	R	Control Voltage	Adapter source voltage. ( mV )
-	3	R	Ambient Temperature	Device ambient temperature as measured from the PCB. ( °C )
-	4	R/W	Max Board Temperature	The maximum board temperature experienced since manufacturing. ( °C )
65	5	R	Dip Switch Value	A bit field representing the present state of the dip switches.
-	6	R	Configuration CRC	A CRC value calculated over the non-volatile data present.
-	7	R/W	Serial Number	32bit Com Adapter Device Serial Number.
-	9	R	Firmware Rev	Com Adapter Firmware Rev.
-	11	R/W	Hardware Rev	Com Adapter Hardware Rev.
1601	101	R/W	Field Relay Outputs	Warning: changing this value may cause the output relay(s) to change state. A bitfield representing the output points. Bit = Description 0 = Output 1 1 = Output 2 Value 0x00: Output 1 Off, Output 2 Off Value 0x01: Output 1 On, Output 2 Off Value 0x02: Output 1 Off, Output 2 On Value 0x03: Output 1 On, Output 2 On
-	102	R/W	Field Inputs Debounce	Array of debounce values. A debounce value exists for each input. The debounce applies to both rising and falling edge. Web interface setting examples (comma separated values): 10,10,10,10 change all four debounce values to 10 msec; 15,20 changes the first two debounce values to 15 msec and 20 msec and leaves the rest unchanged; ,,,30 changes the last debounce value to 30 and leaves the first three unchanged ( milliseconds )
-	110	R/W	Modbus TCP Com Timeout	Communication timeout for Modbus TCP. 0 = Disable. ( milliseconds )
1761	111	R/W	Field Relay Fault Action	When a communication fault occurs the relays can execute two types of behavior. The behavior is selected on a per bit basis. Bit = Description 0 = Relay 1 1 = Relay 2  Bit Value = Description 0 = Apply Fault Value 1 = No Change
1777	112	R/W	Field Relay Fault State	Communication fault value to be applied. A bitfield where each bit defines an output point. Bit Value = Description 0 = Turn Relay Off 1 = Turn Relay On

**Table 102. Register Definitions for S811+ Soft Starter (Cont.)**

Start Coil	Register	Read/Write	Name	Description (Units)
1793	113	R/W	Field Relay Idle Action	When a communication idle state occurs the relays can execute two types of behavior. The behavior is selected on a per bit basis. Bit = Description 0 = Relay 1 1 = Relay 2  Bit Value = Description 0 = Apply Idle Value 1 = No Change
1809	114	R/W	Field Relay Idle State	Communication idle value to be applied. A bitfield where each bit defines an output point. Bit Value = Description 0 = Turn Relay Off 1 = Turn Relay On
-	130	R	Eth Port 1 Speed Actual	Actual Ethernet link speed. ( Mbs )
2097	132	R	Eth Port 1 Full Duplex Enabled	Actual duplex mode True = Full Duplex False = Half Duplex.
-	134	R	Eth Port 1 Autonegotiate State	Active state of the Auto-Negotiation behavior. Value = State 0 = Link Inactive 1 = Auto Negotiation in Progress 2 = Auto Negotiation Failed (Default used) 3 = Auto Negotiation of Duplex Failed (speed ok) 4 = Auto Negotiation Success 5 = Auto Negotiation Disabled 6 = Port Disabled
2145	135	R	Eth Port 1 Enabled	This parameter can disable the Ethernet Port. Effectively disabling the port. True = Enable Port False = Disable Port
-	137	R	Eth Port 2 Speed Actual	Actual Ethernet link speed. ( Mbs )
2209	139	R	Eth Port 2 Full Duplex Enabled	Actual duplex mode. True = Full Duplex False = Half Duplex
-	141	R	Eth Port 2 Autonegotiate State	Active state of the Auto-Negotiation behavior. Value = State 0 = Link Inactive 1 = Auto Negotiation in Progress 2 = Auto Negotiation Failed (Default used) 3 = Auto Negotiation of Duplex Failed (speed ok) 4 = Auto Negotiation Success 5 = Auto Negotiation Disabled 6 = Port Disabled
2257	142	R	Eth Port 2 Enabled	This parameter Indicates whether an Ethernet port is enabled. True = Port Enabled False = Port Disabled
-	143	R	Method of IP Allocation	The method used to allocate an IP Address: 0 - DHCP 1 - Upper three octets from NV and lower octet selected by the dip switch setting. 2 - Full address taken from NV Memory. 3 - Restore (hardcoded 192.168.1.254).

**Table 102. Register Definitions for S811+ Soft Starter (Cont.)**

Start Coil	Register	Read/Write	Name	Description (Units)
-	144	R	Present Ethernet IP Address	The active IP address being used on the network.
-	146	R	Present Ethernet Subnet Mask	The active subnet mask IP address being used on the network.
-	148	R	Present Ethernet Default Gateway	The active default gateway IP address being used on the network.
-	150	R/W	Stored Ethernet IP Address	The IP address used in the NV address select configuration.
-	152	R/W	Stored Ethernet Subnet Mask	The IP subnet mask used in the NV address select configuration.
-	154	R/W	Stored Ethernet Default Gateway	The IP default gateway used in the NV address select configuration.
-	156	R/W	Ethernet MAC Address	Unique MAC Address assigned to this device.
-	159	R/W	Modbus Com Timeout	Communication timeout for Modbus. 0 = Disable. ( milliseconds )
-	160	R/W	Modbus TX mode	Selects the Modbus Mode. 0 - RTU 1 - ASCII
-	161	R/W	Modbus Baud Rate	Selects the Modbus baud rate. 0 - 19.2kb 1 - 9.6kb 2 - 57.6kb 3 - 115.2kb
-	162	R/W	Modbus Address	Modbus address loaded at startup.
-	163	R/W	Modbus Parity and Stop Bits	Selects the Modbus UART parity and Stop Bits. 0 - Even/One Stop Bit 1 - Odd/One Stop Bit 2 - None/Two Stop Bits 3 - Even/Two Stop Bits 4 - Odd/Two Stop Bits 5 - None/One Stop Bit
3201	201	R	Intercom Status	Present state of the Intercom Link. Bit - Status 0 - Connected fully. No error messages. 1 - A message fault occurred. 2 - Devices are married. Target is identified and correct. 3 - A basic connection is established.
4033	253	R/W	Motor Ctrl Com Idle Act Disable	When this value is TRUE the motor state will be unchanged after a communication idle event. A FALSE value will cause the Motor Control Communication Idle Value to be applied on a com idle event.
4049	254	R/W	Motor Ctrl Com Idle Action Val	Action to execute when a communication idle event occurs. 0 = Ignore (No Change) 1 = Stop
-	255	R/W	EtherNet/IP Comm Timeout	EtherNet/IP communication timeout Range: 0-60,000 ms Default: 3000 ms
-	256	R/W	Encapsulation Inactivity Timeout	Number of seconds of inactivity before TCP connection is closed

**Table 102. Register Definitions for S811+ Soft Starter (Cont.)**

Start Coil	Register	Read/Write	Name	Description (Units)
-	300	R	Motor Control Status	Motor Control Status Word for S811+ Bit Description 0 Running1 - RUN1 command active 1 Running2 - Jog command active 2 Permissive - Start allowed (must be 1 to start) 3 Ramp2 - Ramp2 settings active 4 Local Control (0 - network; 1 - local) 5 Faulted - S811+ fault present 6 Warning - S811+ warning present (self clearing) 7 In bypass - S811+ Bypass closed
-	301	R	Active Fault List	Will display up to 3 faults/warnings that are actively present
-	304	R	Motor Control Faults	S811+ Motor Control Fault Bit Field Bit Fault 0 Phaseloss 1 Phase Imbalance 2 Thermal Pile 3 Overcurrent 4 Breaker Fault 5 GND Fault 6 Motor Stall 7 Motor Jam 8 OverTemp 9 UnderLoad 10 Reserved 11 Estop 12 Reserved 13 Reserved 14 Reserved 15 Other
-	305	R	Motor Control Warnings	S811+ Motor Control Warning Bit Field Bit Warning 0 Phaseloss 1 Phase Imbalance 2 Thermal Pile 3 Overcurrent 4 Breaker Fault 5 GND Fault 6 Motor Stall 7 Motor Jam 8 OverTemp 9 UnderLoad 10 Reserved 11 Reserved 12 Reserved 13 Reserved 14 Reserved 15 Other
-	306	R	Average current as % FLA	Average of the 3 phase current as a percentage of the Motor Nameplate fla setting
-	307	R	% Thermal Pile used	Thermal Pile Used Percentage - Trip at 100%
-	308	R	3Ph RMS Mains Voltage	3 Phase RMS Mains voltage reading (in volts)
-	311	R	Total Motor Starts	Number of motor starts
-	313	R	Analog Input Value (% of range)	Analog input reading (in percent of set range)
-	314	R	Analog Input Status	Status of the S811+ analog input 0x00 - Not Active 0x01 - Input under range 0x02 - Input over range 0x03 - Input in overdrive 0x04 - Input is in range

**Table 102. Register Definitions for S811+ Soft Starter (Cont.)**

Start Coil	Register	Read/Write	Name	Description (Units)
-	315	R	S811 Discrete Input Status	The Discrete data Input register will show the active/inactive status of S811+ hardwired and networked inputs. Bits 3..0 indicate the status of the S811+ terminal block inputs and bits 7..4 indicate the status of the network inputs located in the Network Data Input Register (C441 communication adapter inputs#1- 4 when connected) Bit Description 0 S811+ discrete input#1 status 1 S811+ discrete input#2 status 2 S811+ discrete input#3 status 3 S811+ discrete input#4 status 4 Network input#1 status( C441 Com adapter input#1) 5 Network input#2 status( C441 Com adapter input#2) 6 Network input#3 status( C441 Com adapter input#3) 7 Network input#4 status( C441 Com adapter input#4)
-	316	R	S811 Discrete Output Status	The Discrete data Output register bits 1..0 indicate the status of the S811+ relays and bits 3..2 indicate the status of the network outputs being generated by the S811+ configurable output logic(C441 communication adapter outputs#1- 2 when connected) Bit Description 0 S811+ discrete formA relay status 1 S811+ discrete formC relay status 2 Network output#1 status( C441 Com adapter output#1) 3 Network output#2 status( C441 Com adapter output#2) 4 5 6 7
-	317	R	Network Outputs	The network outputs are available as a MODBUS coil that maybe read by the network and any attached C441 communication adapter. The C441 adapters will output the status of the network outputs by default on its Q1 and Q2 relays
-	318	R	Fault Queue	S811+ fault Queue Queue will hold up to the last 10 faults - Fault codes are not repeated in queue
-	328	R	3Ph Average Line Current	Average 3 phase RMS current flowing to the motor
-	330	R	3Ph RMS Line Current	RMS line current reading - This is the actual current flowing to the motor. In inside the delta applications this current will be the pole current multiplied by square root of 3
-	336	R	3Ph Ave Line Current (amps)	Scaled RMS average of the 3phase line current - This is the actual current flowing to the motor in 1.0A.
-	337	R	3Ph RMS Line Current (amps)	Scaled RMS 3phase line current - This is the actual current flowing to the motor in 1.0A.
-	340	R	3Ph Ave Line Current (deci-amps)	Scaled RMS average of the 3phase line current - This is the actual current flowing to the motor in 0.1A.
-	341	R	3Ph RMS Line Current (deci-amps)	Scaled RMS 3phase line current - This is the actual current flowing to the motor in 0.1A.
-	344	R	3Ph Average Pole Current	Average 3 phase RMS current flowing through S811+ power poles

**Table 102. Register Definitions for S811+ Soft Starter (Cont.)**

Start Coil	Register	Read/Write	Name	Description (Units)
-	346	R	3Ph RMS Pole Current	RMS pole current reading - This is the actual current flowing through the power pole of the S811+. In inside the delta applications the actual motor current will be this current multiplied by square root of 3
-	352	R	3Ph Ave Pole Current (amps)	Scaled RMS average of the 3phase pole current - This is the actual current flowing through the power poles of the S811+ in 1.0A
-	353	R	3Ph RMS Pole Current (amps)	Scaled RMS 3phase pole current - This is the actual current flowing through the power poles of the S811+ in 1.0A
-	356	R	3Ph Ave Pole Current (deci-amps)	Scaled RMS average of the 3phase pole current - This is the actual current flowing through the power poles of the S811+ in 0.1A
-	357	R	3Ph RMS Pole Current (deci-amps)	Scaled RMS 3phase pole current - This is the actual current flowing through the power poles of the S811+ in 0.1A
-	360	R	Power Factor	Power factor reading 0 - 1.0000 (in 0.0001)
-	361	R	Ave 3Ph Real Power (kW)	Average 3 phase real power (in kW)
-	362	R	Power Pole Temperature	S811+ power pole temperature in 0.1 degrees C
-	365	R	DC Control Voltage	DC Control Voltage reading in 0.001V
-	366	R	Device Temperature	Device Temperature in 0.1 degrees C
-	367	R	Auto Reset Count	Number of auto reset attempts
-	368	R	Line Frequency	Frequency reading of incoming mains voltage (in 0.01Hz)
-	369	R	Incoming Phase Sequence	Phase sequence of incoming mains voltage 0 - ABC 1 - ACB
-	370	R	Fault List	S811+ fault list List will hold up to the last 10 faults - Fault codes will be repeated in list
-	380	R	Application status	Last active fault
6081	381	R	Run1 Input Level Sense Enable	Reports the logic sense for RUN1 input on the local terminal block (selected by S1 dipswitch) 0x00 - edge sense 0x01 - level sense
-	500	R/W	Modbus Motor Control	Modbus Motor Control Word for S811+ Bit Description 0 Run1 - Normal start bit (edge sense) 1 Jog - Jog motor bit (level sense) 2 Permissive - Allow start (level sense - must be 1 to start) 3 Fault Reset - Reset fault 4 Reserved 5 Reserved 6 Reserved 7 Ramp2 - 2nd ramp profile (uses Ramp2 parameters for start profile)
-	501	R/W	Modbus Two Wire Motor Control	Modbus Two Wire Motor Control Word for S811+ Bit Description 0 Run1 - Normal start bit (level sense) 1 Jog - Jog motor bit (level sense) 2 Reserved 3 Fault Reset - Reset fault 4 Reserved 5 Reserved 6 Reserved 7 Ramp2 - 2nd ramp profile (uses Ramp2 parameters for start profile)

**Table 102. Register Definitions for S811+ Soft Starter (Cont.)**

Start Coil	Register	Read/Write	Name	Description (Units)
-	502	R/W	Network Inputs	The network inputs can be controlled through a MODBUS coil or the I4..I1 inputs of an attached C441 communication adapter.
-	503	R/W	MODBUS Baud Rate	Modbus Baud Rate Code 0 = 1200 1 = 2400 2 = 4800 3 = 9600 4 = 19200 - default value 5 = 38400 6 = 57600 7 = 115200 8 = Reserved Modbus Baud Rate is only updated on power up.
-	504	R	MODBUS Node Address	Modbus Slave Address read from dipswitches - Modbus address is only updated on power up
-	505	R/W	MODBUS Parity	Modbus Parity 0: even (1 stop bit) 1: odd (1 stop bit) 2: no parity (2 stop bits) Modbus parity is only updated on power up
-	506	R/W	MODBUS Stop Bits	Modbus stop bits 1 or 2 (See modbus parity)
-	507	R/W	MODBUS Mode (RTU / ASCII)	Modbus transmission mode 0x00 - RTU mode (default) 0x01 - ASCII mode
-	600	R/W	Motor Nameplate FLA (float)	Full load amperage rating of motor (float)
-	602	R/W	Motor Nameplate FLA in 0.1A	Full load amperage rating of motor scaled in 0.1A ( deci Amps )
-	603	R/W	Overload Trip Class	Overload Trip Class ( 5 - 30; 20 default)
-	604	R/W	Motor Rated Volts	Rated voltage of the motor
-	605	R/W	Incoming Line Frequency Rating	Expected frequency of incoming mains voltage
9681	606	R/W	Motor Wiring Cfg	Motor wiring configuration setting 0 - inline wiring (default) 1 - inside the delta wiring
-	607	R/W	Expected Incoming Phase Sequence	Expected phase sequence of incoming mains 0 - ABC 1 - ACB
-	608	R/W	Motor Start Method	Motor start method 0x00 - rampstart (voltage ramp) 0x01 - current limit (applies a constant voltage during start) 0x02 - reserved 0x03 - pumpstart (when selected, pumpstop is active, softstop is not active)
-	609	R/W	Initial Starting Torque	Starting torque setting for ramp start
-	610	R/W	Start Ramp Time	Motor start ramp time.
-	611	R/W	Stop Ramp Time	Motor stop ramp time. Parameter is not active when start method is set to pump
-	612	R/W	Pump Stop Time	The amount of time to use for the pump stop ramp behavior. Parameter is active when pumpstart is selected for motor start method
-	613	R/W	Kickstart Starting Torque	Initial torque value for the kick start

**Table 102. Register Definitions for S811+ Soft Starter (Cont.)**

Start Coil	Register	Read/Write	Name	Description (Units)
-	614	R/W	Kickstart Duration	The amount of time to apply a kick start 0.0 - 2.0 (in 0.1secs)
-	615	R/W	Ramp2 Expected Phase Sequence	Expected phase sequence of incoming mains for ramp2 start 0 - ABC 1 - ACB
-	616	R/W	Ramp2 Motor Start Method	Motor start method for ramp2 start 0x00 - rampstart (voltage ramp) 0x01 - current limit (applies a constant voltage during start) 0x02 - reserved 0x03 - pumpstart (when selected, ramp2 pumpstop is active, ramp2 softstop is not active)
-	617	R/W	Ramp2 Initial Starting Torque	Starting torque setting for ramp2 start
-	618	R/W	Ramp2 Start Ramp Time	Motor start ramp time for ramp2.
-	619	R/W	Ramp2 Stop Ramp Time	Motor stop ramp time for ramp2. Parameter is not active when ramp2 start method is set to pump
-	620	R/W	Ramp2 Pump Stop Time	The amount of time to use for the pump stop ramp2 behavior. Parameter is active when pumpstart is selected for ramp2 motor start method
-	621	R/W	Ramp2 Kickstart Starting Torque	Initial torque value for the kick start for ramp2
-	622	R/W	Ramp2 Kickstart Duration	The amount of time to apply a kick start 0.0 - 2.0 (in 0.1secs) for ramp2 start
9953	623	R/W	Local Control Only Enable	Local control from terminal block enable 0x00 - disabled (network control possible) 0x01 - enabled (local control from terminal block only)
-	624	R/W	Discrete Input Cfg	Allows custom configuration of the S811+ inputs#1 - #4 and four additional network inputs 0 - no function 1 - run1 2 - ramp2 3 - jog 4 - local control enable 5 - fault reset 6 - e-stop input (active low) 7 - alarm no trip (active low) 8 - external fault (active low) 9 - external warning (active low) 10 - disable overload on start 11 - analog input enable (only for input#4)
-	632	R/W	Analog Input Data Range	Selected range of analog input 0x02 0-20mA range 0x03 4-20mA range
-	633	R/W	Discrete Output Cfg	Allows custom configuration of the two S811+ aux relays and two additional network outputs 0 - no function 1 - faulted 2 - not faulted 3 - in bypass 4 - not in bypass 5 - motor is energized 6 - motor is not energized 7 - warning 8 - not warning 9 - custom code (up to 3 specific codes can be entered to trip this output) 10 - not custom code

**Table 102. Register Definitions for S811+ Soft Starter (Cont.)**

Start Coil	Register	Read/Write	Name	Description (Units)
-	637	R/W	Custom Fault Output Cfg	User can select up to 3 specific fault/warning codes which will be used to trip any outputs configured for "custom codes"
-	640	R/W	Fault Reset Mode	Fault reset mode 0x00 - manual reset 0x01 - auto reset 0x02 - power on reset (reset faults on power cycle)
-	641	R/W	Auto Reset Delay Time	Delay time after fault before attempting to auto reset
-	642	R/W	Auto Reset Attempt Limit	Max number of auto reset attempts; once reached, S811 requires manual reset to clear fault
-	643	R/W	Overload Trip Enable	Motor overload trip enable 0x00 - disable 0x01 - fault enable 0x02 - warning enable
10289	644	R/W	Enable Overload During Start	Enable the overload during start ramp 0x00 - overload is disabled during start ramp 0x01 - overload is enabled during start ramp
-	645	R/W	Phase Reversal Trip Enable	Phase reversal trip enable 0x00 - disable 0x01 - fault enable 0x02 - warning enable
-	646	R/W	Undercurrent Trip Enable	Low load current trip enable 0x00 - disable 0x01 - fault enable 0x02 - warning enable
-	647	R/W	Undercurrent Trip Level (% FLA)	Low load current trip threshold in percent of the motor nameplate fla setting
-	648	R/W	Undercurrent Trip Duration	Amount of time a low current condition must exist before a trip; 0.0 - 60.0 (in 0.1secs)
-	649	R/W	Motor Jam Trip Enable	Motor jam trip enable 0x00 - disable 0x01 - fault enable 0x02 - warning enable
-	650	R/W	Motor Stall Trip Enable	Motor stall trip enable 0x00 - disable 0x01 - fault enable 0x02 - warning enable
-	651	R/W	Phase Loss Trip Enable	Motor phase loss trip enable 0x00 - disable 0x01 - fault enable 0x02 - warning enable
-	652	R/W	Motor Phase Loss Trip Level	Current phase loss trip threshold
-	653	R/W	Motor Phase Loss Duration	Amount of time a phase loss condition must exist before a trip; 0.0 - 60.0 (in 0.1secs)
-	654	R/W	Phase Imbalance Trip Enable	Current phase imbalance trip enable 0x00 - disable 0x01 - fault enable 0x02 - warning enable
-	655	R/W	Motor Phase Imbalance Trip Level	Current imbalance trip threshold
-	656	R/W	Motor Phase Imbalance Trip Duration	Amount of time a current imbalance condition must exist before a trip; 0.0 - 60.0 (in 0.1secs)
-	657	R/W	Voltage Imbalance Trip Level	Voltage imbalance trip threshold
-	658	R/W	Voltage Imbalance Trip Duration	Amount of time a voltage imbalance condition must exist before a trip; 0.0 - 60.0 (in 0.1secs)

**Table 102. Register Definitions for S811+ Soft Starter (Cont.)**

Start Coil	Register	Read/Write	Name	Description (Units)
-	659	R/W	Under Voltage Trip Enable	Under voltage trip enable 0x00 - disable 0x01 - fault enable 0x02 - warning enable
-	660	R/W	Under Voltage Trip Threshold	Under voltage trip threshold (in percent of rated motor voltage)
-	661	R/W	Under Voltage Trip Duration	Amount of time an under voltage condition must exist before a trip; 0.0 - 60.0 (in 0.1secs)
-	662	R/W	Over Voltage Trip Enable	Over voltage trip enable 0x00 - disable 0x01 - fault enable 0x02 - warning enable
-	663	R/W	Over Voltage Trip Threshold	Over voltage trip threshold (in percent of rated motor voltage)
-	664	R/W	Over Voltage Trip Duration	Amount of time an over voltage condition must exist before a trip; 0.0 - 60.0 (in 0.1secs)
-	665	R/W	Line Frequency Trip	Line frequency deviation trip enable 0x00 - disable 0x01 - fault enable 0x02 - warning enable
-	666	R/W	Frequency Deviation Trip Threshold	Line frequency deviation trip threshold (in percent of rated line frequency)
-	667	R/W	Frequency Trip Duration	Amount of time a frequency deviation condition must exist before a trip; 0.0 - 60.0 (in 0.1secs)
-	668	R/W	Ave Power Trip Enable	Average power trip enable 0x00 - disable 0x01 - fault enable 0x02 - warning enable
-	669	R/W	Ave Power Low Trip Threshold	Low power trip threshold (in percent of rated W) rated W = $\sqrt{3} \times 0.8PF \times \text{motor fla} \times \text{rated motor voltage}$
-	670	R/W	Ave Power High Trip Threshold	High power trip threshold (in percent of rated W) rated W = $\sqrt{3} \times 0.8PF \times \text{motor fla} \times \text{rated motor voltage}$
-	671	R/W	Ave Power Trip Duration	Amount of time a low or high power condition must exist before a trip; 0.0 - 60.0 (in 0.1secs)
-	672	R/W	Analog Input Trip Enable	Analog input trip enable 0x00 - disable 0x01 - fault enable 0x02 - warning enable
-	673	R/W	Analog Input Trip Low Threshold	Low analog input trip threshold (in percent of selected analog range)
-	674	R/W	Analog Input Trip High Threshold	High analog input trip threshold (in percent of selected analog range)
-	675	R/W	Analog Input Trip Duration	Amount of time a low or high analog input condition must exist before a trip; 0.0 - 60.0 (in 0.1secs)
-	676	R/W	Temperature Sensor Trip Enable	Temperature sensor trip enable 0x00 - disable 0x01 - fault enable 0x02 - warning enable
-	677	R/W	SCR Not Firing Trip Enable	SCR not firing trip enable 0x00 - disable 0x01 - fault enable 0x02 - warning enable
-	678	R/W	SCR Shorted Trip Enable	Shorted SCR trip enable 0x00 - disable 0x01 - fault enable 0x02 - warning enable

**Table 102. Register Definitions for S811+ Soft Starter (Cont.)**

Start Coil	Register	Read/Write	Name	Description (Units)
10849	679	R/W	Alarm - No Trip Enabled	Alarm no trip enable allows the S811+ to continue to run through any motor faults. Fault will be issued but will not stop the starter. Faults meant to protect the softstarter will continue to trip the starter
10865	680	R/W	Start Delay Active Warning Enable	Enables warning when start delay timers are used. Warning is issued while start command is pending
-	681	R/W	Start Delay After Power up	Time delay after power up before a start command can be issued
-	682	R/W	Start Delay	Time delay after a start command is issued before the S811+ will attempt start
-	683	R/W	Start Delay After Run Change	User settable time delay between successive start profiles. Delay becomes active when start profile(ramp vs ramp2) changes between starts
-	684	R/W	Motor Comm Loss Action	Motor comloss action 0x00 - auto stop 0x01 - auto run1 0x02 - unavailable 0x03 - hold last state 0x04 - unavailable 0x05 - unavailable 0x06 - unavailable 0x07 - all stop fault (will trip S811+ and issue all stop fault)
-	685	R/W	Transient Motor Control Timeout	Motor control timeout for transient UI devices
-	686	R/W	Motor Control Command Timeout	Motor control timeout - communication idle time which will cause a Motor Control Device Missing fault
10977	687	R/W	Network two wire control enable	Network two wire control parameter enable 0 - 3wire control (Modbus reg #500 active) 1 - 2wire control (Modbus reg #501 active)
-	688	R/W	GND Fault Enable	GND fault trip enable 0x00 - disable 0x01 - fault enable 0x02 - warning enable
-	689	R/W	GND Fault Inhibit From Start Delay	Parameter will mask the GND fault trip from the end of start ramp; 0.0 - 20.0 in 0.1secs; Example: ramp time = 20, GND delay = 5, GND fault will be masked for 25 seconds after start command
-	690	R	Firmware Version List	Firmware version - AVR, DSP
-	692	R	Hardware Version	Hardware version
-	800	R/W	Modbus Device Reset Register	Register performs reset services on S811+ over modbus 0x00 - no reset 0x01 - soft reset (power cycle reset) 0x02 - factory reset (reset device back to defaults) 0x03 - app parameter reset 0x04 - reserved 0x05 - reserved 0x06 - flush fault queue/list
-	900	R/W	Modbus User Application Name	User defined ASCII name.



**Table 102. Register Definitions for S811+ Soft Starter (Cont.)**

Start Coil	Register	Read/Write	Name	Description (Units)
-	1000	R/W	Modbus Production List	The Production and consumption Registers can be used to create custom Modbus interface ranges. An example: If field inputs register address 0 is put into the first slot of the production list, the field inputs register value will be available in the first slot of the Modbus Production Data Register range. Production data is data provided by the device and Consumption data is for data provided (written) to the device. Note that the values must be Modbus Register Address (i.e., Register Number - 1) not Register Number Web setting examples (comma separated values): 1,2 sets the first two slots as 1 and 2, and leaves all the rest unchanged; ,, 3 sets the third slot as 3 and leaves all the rest unchanged
-	2000	R	Modbus Production Data	-
-	3000	R/W	Modbus Consumption List	The Production and consumption Registers can be used to create custom Modbus interface ranges. An example: If field inputs register address 0 is put into the first slot of the production list, the field inputs register value will be available in the first slot of the Modbus Production Data Register range. Production data is data provided by the device and Consumption data is for data provided (written) to the device. Note that the values must be Modbus Register Address (i.e., Register Number - 1) not Register Number. Web setting examples (comma separated values): 1,2 sets the first two slots as 1 and 2, and leaves all the rest unchanged; ,, 3 sets the third slot as 3 and leaves all the rest unchanged
-	4000	R/W	Modbus Consumption Data	-

**7.6 Register Definitions for Use as Stand Alone I/O**

**Table 103. Registers Available when Used as Stand Alone I/O**

Start Coil	Register	Read/Write	Name	Description (Units)
1	1	R	Field Inputs	A Bitfield Representing the Input Points. Bit = Description 0 = Input 1 1 = Input 2 2 = Input 3 3 = Input 4
-	2	R	Control Voltage	Adapter Source Voltage. ( mV )
-	3	R	Ambient Temperature	Device Ambient Temperature as Measured from the PCB. ( °C )
-	4	R/W	Max Board Temperature	The Maximum Board Temperature Experienced Since Manufacturing. ( °C )
65	5	R	Dip Switch Value	A Bit Field Representing the Present State of the Dip Switches.
-	6	R	Configuration CRC	A CRC Value Calculated Over the Non-volatile Data Present.
-	7	R/W	Serial Number	32 bit Com Adapter Device Serial Number.
-	9	R	Firmware Rev	Com Adapter Firmware Rev.
-	11	R/W	Hardware Rev	Com Adapter Hardware Rev.
1601	101	R/W	Field Relay Outputs	A Bitfield Representing the Output Points. Bit = Description 0 = Output 1 1 = Output 2
-	102	R/W	Field Inputs Debounce	Array of Debounce Values. A debounce value exists for each input. The debounce applies to both rising and falling edge. (milliseconds )
-	110	R/W	Modbus TCP Com Timeout	Communication Timeout for Modbus TCP. 0 = Disable. (milliseconds )
1761	111	R/W	Field Relay Fault Action	When a communication fault occurs the relays can execute two types of behavior. The behavior is selected on a per bit basis. Bit = Description 0 = Relay 1 1 = Relay 2  Bit Value = Description 0 = Apply Fault Value 1 = No Change
1777	112	R/W	Field Relay Fault State	Communication fault value to be applied. A bitfield where each bit defines an output point. Bit Value = Description 0 = Turn Relay Off 1 = Turn Relay On
1793	113	R/W	Field Relay Idle Action	When a communication idle state occurs the relays can execute two types of behavior. The behavior is selected on a per bit basis. Bit = Description 0 = Relay 1 1 = Relay 2  Bit Value = Description 0 = Apply Idle Value 1 = No Change
1809	114	R/W	Field Relay Idle State	Communication idle value to be applied. A bitfield where each bit defines an output point. Bit Value = Description 0 = Turn Relay Off 1 = Turn Relay On

**Table 103. Registers Available when Used as Stand Alone I/O  
(Cont.)**

Start Coil	Register	Read/Write	Name	Description (Units)
-	143	R	Method of IP Allocation	The method used to allocate an IP Address: 0 - DHCP 1 - Upper three octets from NV and lower octet selected by the dip switch setting. 2 - Full address taken from NV Memory. 3 - Restore (hardcoded 192.168.1.254).
-	144	R	Present Ethernet IP Address	The active IP address being used on the network.
-	146	R	Present Ethernet Subnet Mask	The active subnet mask IP address being used on the network.
-	148	R	Present Ethernet Default Gateway	The active default gateway IP address being used on the network.
-	150	R/W	Stored Ethernet IP Address	The IP address used in the NV address select configuration.
-	152	R/W	Stored Ethernet Subnet Mask	The IP subnet mask used in the NV address select configuration.
-	154	R/W	Stored Ethernet Default Gateway	The IP default gateway used in the NV address select configuration.
-	156	R/W	Ethernet MAC Address	-
-	230	R/W	EtherNet/IP Comm Timeout	EtherNet/IP communication timeout Range: 0–60,000 ms Default: 3000 ms
-	231	R/W	Encapsulation Inactivity Timeout	Number of seconds of inactivity before TCP connection is closed
-	1000	R/W	Modbus Production List	The Production and consumption Registers can be used to create custom Modbus interface ranges. An example: If field inputs register address 0 is put into the first slot of the production list, the field inputs register value will be available in the first slot of the Modbus Production Data Register range. Production data is data provided by the device and Consumption data is for data provided (written) to the device. Note that the values must be Modbus Register Address (i.e., Register Number - 1) not Register Number.
-	2000	R	Modbus Production Data	-
-	3000	R/W	Modbus Consumption List	The Production and consumption Registers can be used to create custom Modbus interface ranges. An example: If field inputs register address 0 is put into the first slot of the production list, the field inputs register value will be available in the first slot of the Modbus Production Data Register range. Production data is data provided by the device and Consumption data is for data provided (written) to the device. Note that the values must be Modbus Register Address (i.e., Register Number - 1) not Register Number.
-	4000	R/W	Modbus Consumption Data	-

**Notes:**

This user manual is published solely for informational purposes and should not be considered all-inclusive. If further information is required, you should consult Eaton. Sale of product shown in this literature is subject to terms and conditions outlined in appropriate Eaton selling policies or other contractual agreements between the parties. This literature is not intended to and does not enlarge or add to any such contract. The sole source governing the rights and remedies of any purchaser of this equipment is the contract between the purchaser and Eaton.

NO WARRANTIES, EXPRESSED OR IMPLIED, INCLUDING WARRANTIES OF FITNESS FOR A PARTICULAR PURPOSE OF MERCHANTABILITY, OR WARRANTIES ARISING FROM COURSE OF DEALING OR USAGE OF TRADE, ARE MADE REGARDING THE INFORMATION, RECOMMENDATIONS AND DESCRIPTIONS CONTAINED HEREIN.

In no event will Eaton be responsible to the purchaser or user in contract, in tort (including negligence), strict liability or otherwise for any special, indirect, incidental or consequential damage or loss whatsoever, including but not limited to damage or loss of use of equipment, plant or power system, cost of capital, loss of power, additional expenses in the use of existing power facilities or claims against the purchaser or user by its customers resulting from the use of the information, recommendations and description contained herein.



## Licenses

This product includes embedded software that incorporates or interfaces with the following third party software:

---

lwIP is licensed under the BSD license:

Copyright (c) 2001-2004 Swedish Institute of Computer Science.

All rights reserved.

Redistribution and use in source and binary forms, with or without modification, are permitted provided that the following conditions are met:

1. Redistributions of source code must retain the above copyright notice, this list of conditions and the following disclaimer.
2. Redistributions in binary form must reproduce the above copyright notice, this list of conditions and the following disclaimer in the documentation and/or other materials provided with the distribution.
3. The name of the author may not be used to endorse or promote products derived from this software without specific prior written permission.

THIS SOFTWARE IS PROVIDED BY THE COPYRIGHT HOLDER "AS IS" AND ANY EXPRESS OR IMPLIED WARRANTIES, INCLUDING, BUT NOT LIMITED TO, THE IMPLIED WARRANTIES OF MERCHANTABILITY AND FITNESS FOR A PARTICULAR PURPOSE ARE DISCLAIMED. IN NO EVENT SHALL THE AUTHOR BE LIABLE FOR ANY DIRECT, INDIRECT, INCIDENTAL, SPECIAL, EXEMPLARY, OR CONSEQUENTIAL DAMAGES (INCLUDING, BUT NOT LIMITED TO, PROCUREMENT OF SUBSTITUTE GOODS OR SERVICES; LOSS OF USE, DATA, OR PROFITS; OR BUSINESS INTERRUPTION) HOWEVER CAUSED AND ON ANY THEORY OF LIABILITY, WHETHER IN CONTRACT, STRICT LIABILITY, OR TORT (INCLUDING NEGLIGENCE OR OTHERWISE) ARISING IN ANY WAY OUT OF THE USE OF THIS SOFTWARE, EVEN IF ADVISED OF THE POSSIBILITY OF SUCH DAMAGE.

---

[www.FreeRTOS.org](http://www.FreeRTOS.org)

**Eaton**  
1000 Eaton Boulevard  
Cleveland, OH 44122  
United States  
Eaton.com

© 2016 Eaton  
All Rights Reserved  
Printed in USA  
Publication No. MN04200002E / Z17638  
January 2016