

# Operating instructions

**DEA**<sup>®</sup>  
move as you like

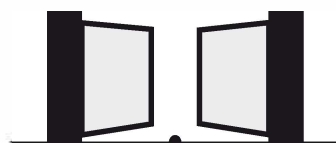

[www.deasystem.com](http://www.deasystem.com)

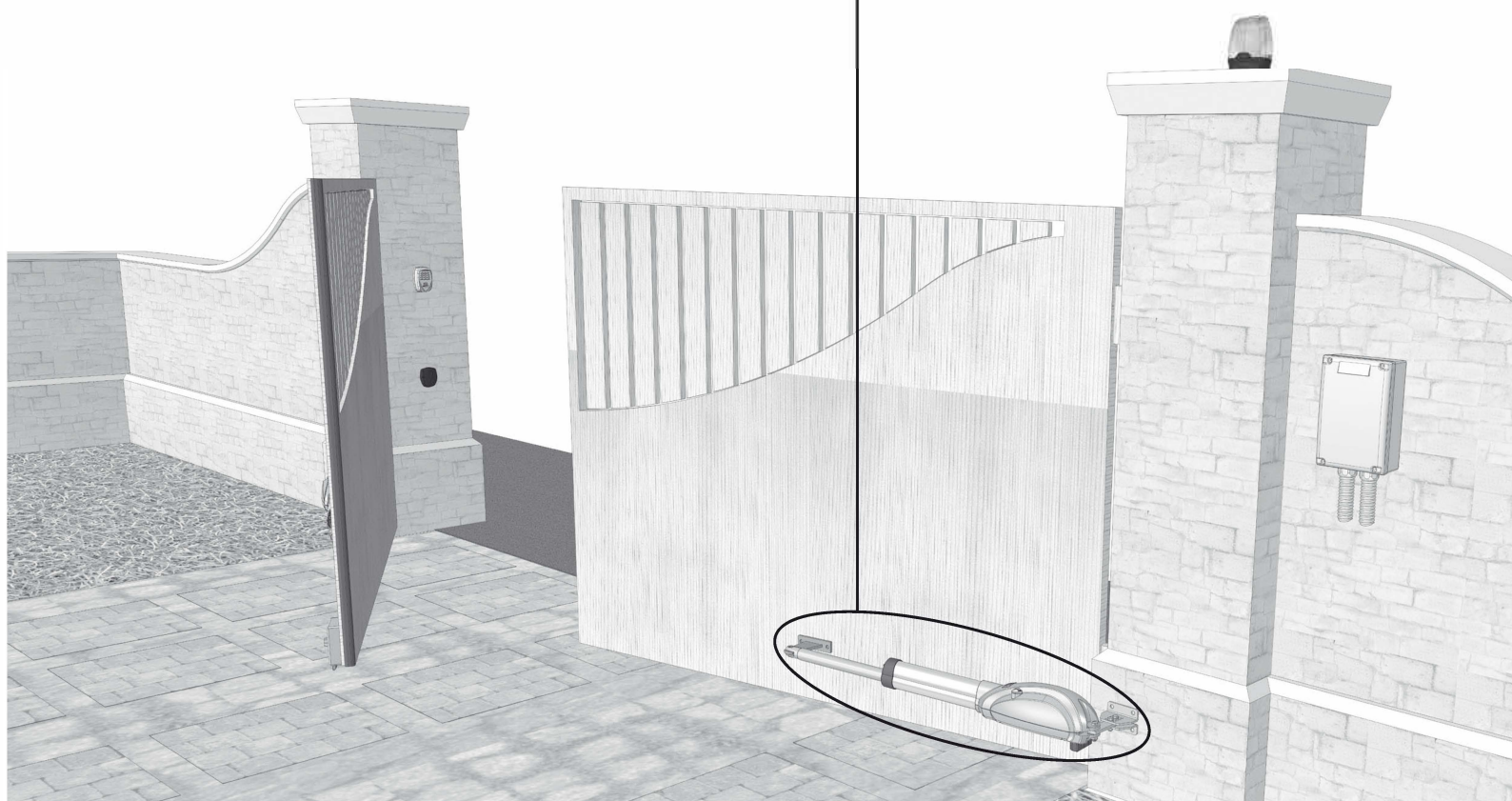

# LOOK

#### Index

<b>1</b>	Warnings Summary	<b>7</b>	<b>6</b>	Start-up	<b>10</b>
<b>2</b>	Product Description	<b>8</b>	<b>6.1</b>	Installation Test	<b>10</b>
<b>3</b>	Technical data	<b>8</b>	<b>6.2</b>	Unlocking and manual operation	<b>10</b>
<b>4</b>	Installation and Assembly	<b>8</b>	<b>7</b>	Maintenance	<b>11</b>
<b>5</b>	Electrical Connections	<b>9</b>	<b>8</b>	Product Disposal	<b>11</b>

## Product Conformity

LOOK bears the CE label. **DEA** System guarantees the conformity of the product to European Directives 2006/42/CE regarding “machinery safety”, 2004/108/CE “electromagnetic compatibility” and 2006/95/CE “low voltage electrical equipment”. See **Declaration of Incorporation**.

## 1 WARNINGS SUMMARY

Read these warnings carefully; failure to respect the following warnings may cause risk situations.

**⚠ WARNING** USING THIS PRODUCT UNDER UNUSUAL CONDITIONS NOT FORESEEN BY THE MANUFACTURER CAN CREATE SITUATIONS OF DANGER, AND FOR THIS REASON ALL THE CONDITIONS PRESCRIBED IN THESE INSTRUCTIONS MUST BE RESPECTED.

**⚠ WARNING** **DEA** SYSTEM REMINDS ALL USERS THAT THE SELECTION, POSITIONING AND INSTALLATION OF ALL MATERIALS AND DEVICES WHICH MAKE UP THE COMPLETE AUTOMATION SYSTEM, MUST COMPLY WITH THE EUROPEAN DIRECTIVES 2006/42/CE (MACHINERY DIRECTIVE), 2004/108/CE (ELECTROMAGNETIC COMPATIBILITY), 2006/95/CE (LOW VOLTAGE ELECTRICAL EQUIPMENT). IN ORDER TO ENSURE A SUITABLE LEVEL OF SAFETY, BESIDES COMPLYING WITH LOCAL REGULATIONS, IT IS ADVISABLE TO COMPLY ALSO WITH THE ABOVE MENTIONED DIRECTIVES IN ALL EXTRA EUROPEAN COUNTRIES.

**⚠ WARNING** UNDER NO CIRCUMSTANCES MUST THE PRODUCT BE USED IN EXPLOSIVE ATMOSPHERES OR SURROUNDINGS THAT MAY PROVE CORROSIVE AND DAMAGE PARTS OF THE PRODUCT.

**⚠ WARNING** TO ENSURE AN APPROPRIATE LEVEL OF ELECTRICAL SAFETY ALWAYS KEEP THE 230V POWER SUPPLY CABLES APART (MINIMUM 4MM IN THE OPEN OR 1 MM THROUGH INSULATION) FROM LOW VOLTAGE CABLES (MOTORS POWER SUPPLY, CONTROLS, ELECTRIC LOCKS, AERIAL AND AUXILIARY CIRCUITS POWER SUPPLY), AND FASTEN THE LATTER WITH APPROPRIATE CLAMPS NEAR THE TERMINAL BOARDS.

**⚠ WARNING** ALL INSTALLATION, MAINTENANCE, CLEANING OR REPAIR OPERATIONS ON ANY PART OF THE SYSTEM MUST BE PERFORMED EXCLUSIVELY BY QUALIFIED PERSONNEL WITH THE POWER SUPPLY DISCONNECTED WORKING IN STRICT COMPLIANCE WITH THE ELECTRICAL STANDARDS AND REGULATIONS IN FORCE IN THE NATION OF INSTALLATION.

**⚠ WARNING** USING SPARE PARTS NOT INDICATED BY **DEA** SYSTEM AND/OR INCORRECT RE-ASSEMBLY CAN CREATE RISK TO PEOPLE, ANIMALS AND PROPERTY AND ALSO DAMAGE THE PRODUCT. FOR THIS REASON, ALWAYS USE ONLY THE PARTS INDICATED BY **DEA** SYSTEM AND SCRUPULOUSLY FOLLOW ALL ASSEMBLY INSTRUCTIONS.

**⚠ WARNING** INCORRECT ASSESSMENT OF THE IMPACT FORCES CAN CAUSE SERIOUS DAMAGE TO PEOPLE, ANIMALS OR THINGS. **DEA** SYSTEM REMINDS THE INSTALLER MUST VERIFY THAT THE IMPACT FORCES, MEASURED AS INDICATED BY THE STANDARD EN 12445, ARE ACTUALLY BELOW THE LIMITS SET BY THE STANDARD EN12453.

**⚠ WARNING** ANY EXTERNAL SECURITY DEVICES USED FOR COMPLIANCE WITH THE LIMITS OF IMPACT FORCES MUST BE CONFORM TO STANDARD EN12978.

**♻ WARNING** IN COMPLIANCE WITH EU DIRECTIVE 2002/96/EC ON WASTE ELECTRICAL AND ELECTRONIC EQUIPMENT (WEEE), THIS ELECTRICAL PRODUCT SHOULD NOT BE TREATED AS MUNICIPAL MIXED WASTE. PLEASE DISPOSE OF THE PRODUCT AND BRING IT TO THE COLLECTION FOR AN APPROPRIATE LOCAL MUNICIPAL RECYCLING.

## 2 PRODUCT DESCRIPTION

### Models and contents of the package

LOOK identifies a family of operators with different characteristics as regards the supply voltage, the reversibility and the presence of the encoder.

LOOK is designed for installation in residential swing gates, is composed primarily of a mechanical gear motor that drives the lead screw fastened to the front attachment by means of the adjustment screw.

LOOK is completed by a set of accessories listed in the "PRODUCT ACCESSORIES" table (page 43).

Inspect the "Contents of the Package" (Pic. 1) and compare it with your product for useful consultation during assembly.

### Transport

LOOK is always delivered packed in boxes that provide adequate protection to the product, however, pay attention to all information that may be provided on the same box for storage and handling.

## 3 TECHNICAL DATA

	351/SC - 352/SC - 351EN/SC	355/SC - 356/SC - 355EN/SC	353/SC - 354/SC	357/SC - 358/SC	371/SC - 371EN/SC - 372/SC	373/SC - 374/SC - 373EN/SC	371E/SC
Motor power supply voltage (V)	230 V ~ ±10% (50/60 Hz)				24 V ===		
Absorbed power (W)	300				60	50	
Max Thrust (N)	1650	1200		1000		500	
Duty cycle (cycles/hour)	22 - 25 (351EN)				40	10	
Maximum n° of operations in 24 hour	110				110	50	
Built-in capacitor (µF)	8	10		/			
Operating temperature range (°C)	-20+50 °C						
Motor thermal protection (°C)	150				/		
Opening time 90° (s)	16	12,5	17	13,5	14	15	15
Weight of product with package (Kg)	9	9,5	9	9,5	9		
Protection degree	IP24						

## 4 INSTALLATION AND ASSEMBLY

### 4.1 For a satisfactory installation of the product is important to:

- Verify that the gate complies with the legal requirements and then define the complete project of the installation;
- Verify that the gate is well balanced and that it has no points of friction in opening and closing;
- Identify an area that allows a smooth and safe manual operation of the operator;
- Verify that the operator bulk (Pic. 2) is compatible with the area chosen for the fitting (Pic. 3);
- Use the length/weight graphic and the provided installations dimensions (Pic. 4) evaluating whether you prefer a 90° or higher opening (Pic. 4).

### 4.2 Defined and satisfied these prerequisites, proceed to the assembly:

- Fix the rear junction to the pillar by welding (Pic. 5);
- Fix the front junction to the gate by welding (Pic. 6);
- Keeping the motor in a horizontal position, mount it first to the front bracket, then to the rear bracket (Pic. 7) ensuring that installation dimensions shown in Picture 4 are respected.

**WARNING** In order to make the structure sufficiently strong, reinforcement plates to be fixed to attachments may be necessary.

**WARNING** Grease pins before assembly.

### 4.3 How to unlock the operator

- Turn the cap placed on the back of LOOK in order to discover the underlying shaped hole;
- Insert the release key inside the shaped hole paying attention to the direction of insertion (Pic. 8.a);
- Rotate 90 degrees (counterclockwise to unlock, clockwise to lock) the release key (Pic. 8.b).

**WARNING** Remember to protect the lock with the respective cover so that the operator is protected by water or powder (even when it remains unlocked for a long time).

**WARNING** During this operation gate may perform uncontrolled movements: operate with extra care so to avoid any risk.

## 4.4 Adjustment of the limit-switches

After the installing, limit switches must be adjusted (only for models that foresee them) as follows (Pic. 9):

**WARNING** When adjusting the limit switches, take away the little cover of the extrusion using a screwdriver and check the correct internal microswitches are moving (Pic. 10).

- Unscrew the A fixing nuts so to operate on C and D screws
- Adjust opening and closing limit switches
- Screw the A fixing screws by keeping C and D blocked by a screwdriver so to maintain the adjustments.

**WARNING** While closing the inspection cover, use silicone to seal the leak (Pic. 11).

## 5 ELECTRICAL CONNECTIONS

**WARNING** To ensure an appropriate level of electrical safety always keep the 230V power supply cables apart (minimum 4mm in the open or 1 mm through insulation) from low voltage cables (motors power supply, controls, electric locks, aerial and auxiliary circuits power supply), and fasten the latter with appropriate clamps near the terminal boards.

**WARNING** To connect the encoder to the control panel, use only a dedicated cable 3x0,22mm<sup>2</sup>.

**WARNING** During the connection phase, fasten the electric cables with appropriate clamps near the terminal boards and, when possible, unsheathe the cables to avoid they are too long.

EN

### Connection for 24V and 230V

- Remove the plastic cover positioned under LOOK (Pic. 12).
- Open one of four shaped holes and choose where the cable exit has to be (Pic. 13).
- Introduce the cable clamp and fix it by its nut (Pic. 14).
- Insert the power supply cable into the clamp (coming from the control panel): A quadropole cable suitable for external applications with a 4x1mm<sup>2</sup> section (or 3x1,5mm<sup>2</sup> for 24V operators) (minimum H05RN-F type) coming directly from the control panel (without any connection and shunt box) and supplied by the installer (Pic. 15).

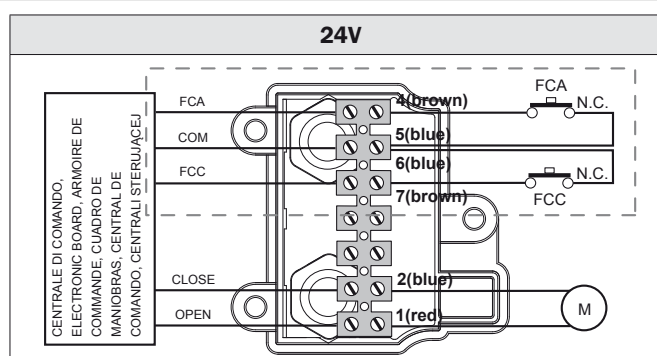

### Connection for 24V and 230V with limit switches

- For the operator power supply connection follow the instructions of the basic version.
- Open a second hole in the plastic cover and apply the second provided cable clamp (a reduced M16).
- Use a 3x0,75mm<sup>2</sup> cable (not supplied) for a correct limit switches wiring to the control panel.

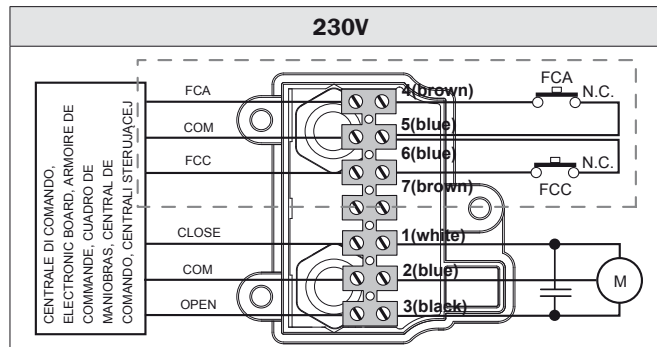

### Connection for 230V version with encoder

- For the operator power supply connection follow the instructions of the basic version.
- Open a second hole in the plastic cover and apply the second provided cable clamp (a reduced M16).
- Use a 3x0,25mm<sup>2</sup> LiYY (DEA art. 182021) to be ordered a part) and follow the diagram to correctly connect the encoder to the control board.
- Use the cable with panduit connector supplied in the kit to connect the previously used cable to the control board, by using the clamp 3 "poli" inside the package.

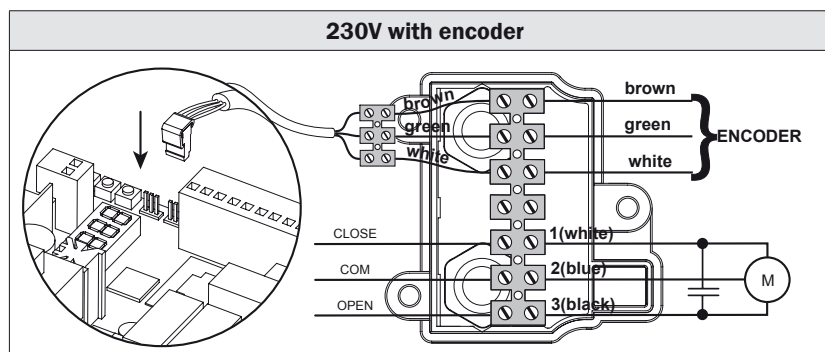

**WARNING** Maintain the ground conductor at a major length respect the active conductors so that, if the cable exit from its fixing housing, the active conductors tighten up as first.

**WARNING** Respect the Phase-Neutral polarity of the tension as explained by the instructions manual of the control panels of LOOK.

- Re-assemble the plastic cover ensuring that any cable do not touch moving parts of the operator.

**WARNING** while installing, maintain a proper distance between the power cable conductors and the operator.

Program the control board to complete all adjustments. It is now possible to supply a complete installation in compliance with all standards required for gate automation. See the instructions provided with the control panel to be connected.

Finally, verify that all adjustments operations have been correctly performed and that safety devices and unlocking device properly work.

## 6 START-UP

The start-up phase is very important to ensure maximum security and compliance to regulations, including all the requirements of EN 12445 standard which establishes the test methods for testing the automation for gates.

**DEA System** reminds that all installation, maintenance, cleaning or repair operations on any part of the system must be performed exclusively by qualified personnel who must be responsible of all texts requie by the eventual risk;

### 6.1 Installation test

The testing operation is essential in order to verify the correct installation of the system. **DEA System** wants to summarize the proper testing of all the automation in 4 easy steps:

- Make sure that you comply strictly as described in paragraph 2 "WARNINGS SUMMARY";
- Test the opening and closing making sure that the movement of the leaf match as expected. We suggest in this regard to perform various tests to assess the smoothness of the gate and defects in assembly or adjustment;
- Ensure that all safety devices connected work properly;
- Perform the measurement of impact forces in accordance with the standard 12445 to find the setting that ensures compliance with the limits set by the standard EN12453.

**WARNING** Using spare parts not indicated by **DEA System** and/or incorrect re-assembly can create a risk to people, animals and property and also damage the product. For this reason, always use only the parts indicated by **DEA System** and scrupulously follow all assembly instructions.

### 6.2 Unlocking and Manual operation

In the event of malfunctions or simple power failure, release the motor (Pic. 8) and perform the operation manually.

The knowledge of the unlocking operation is very important, because in times of emergency the lack of timeliness in acting on such a device can be dangerous.

**WARNING** The efficacy and safety of manual operation of the automation is guaranteed by **DEA System** only if the installation has been installed correctly and with original accessories.

## 7 MAINTENANCE

Good preventive maintenance and regular inspection ensure long working life. In the table below you will find a list of inspections/ maintenance operations to be programmed and executed periodically.

Consult the "TROUBLE-SHOOTING" table whenever anomalies are observed in order to find the solution to the problem and contact **DEA System** directly whenever the solution required is not provided.

INTERVENTION TYPE	PERIODICITY
cleaning of external surfaces	6 months
checking of screw tightening	6 months
checking of release mechanism operation	6 months
greasing of articulated joint	1 year

TROUBLE-SHOOTING	
Description	Possible solutions
When the opening command is given, the leaf fails to move and the operator's electric motor fails to start.	The operator is not receiving correct power supply. Check all connections, fuses, and the power supply cable conditions and replace or repair if necessary. Check that the unlocking system is closed (see Pic.8).
When the opening command is given, the motor starts but the leaf fails to move.	Make sure that the electronic device for electric power adjustment is in good condition. If the piston remains at the complete end of its stroke when the gate is closed, review the assembly procedure.
The operator jerks during movement.	If the leaf does not move freely, release the ram and readjust the rotation points.
	The power of the gear motor may be insufficient for the characteristics of the gate's wing; check the choice of model whenever required.
	The operator's front and rear attachments bend or are not fastened correctly. Repair or replace.

## 8 PRODUCT DISPOSAL

LOOK consists of materials of various types, some of which can be recycled (electrical cables, plastic, aluminum, etc. ...) while others must be disposed of (electronic boards and components).

Proceed as follows:

1. Disconnect the power supply;
2. Disconnect and disassemble all the accessories connected. Follow the instructions in reverse to that described in the section "Installation";
3. Remove the electronic components;
4. Sorting and disposing of the materials exactly as per the regulations in the country of sale.



**WARNING** In line with EU Directive 2002/96/EC for waste electrical and electronic equipment (WEEE), this electrical product must not be disposed of as unsorted municipal waste. Please dispose of this product by returning it to your local municipal collection point for recycling.

# typical installation

**DEA** System provides the following instructions which are valid for a typical system but obviously not complete for every system. For each automatism the installer must carefully evaluate the real conditions existing at the site. The installation requisites in terms of both performance and safety must be based upon such considerations, which will also form the basis for the risk analysis and the detailed design of the automatism.

Pos.	Description				
1	Anti lock-picking key switch KYO				
2	Remote-control				
3	Safety edge				
4	Radio keypad DIGIrad				
5	104 Lux photocells				
6	Electric lock				
7	1Pilly 60 column				
8	LOOK				
9	Lumy flashing light				

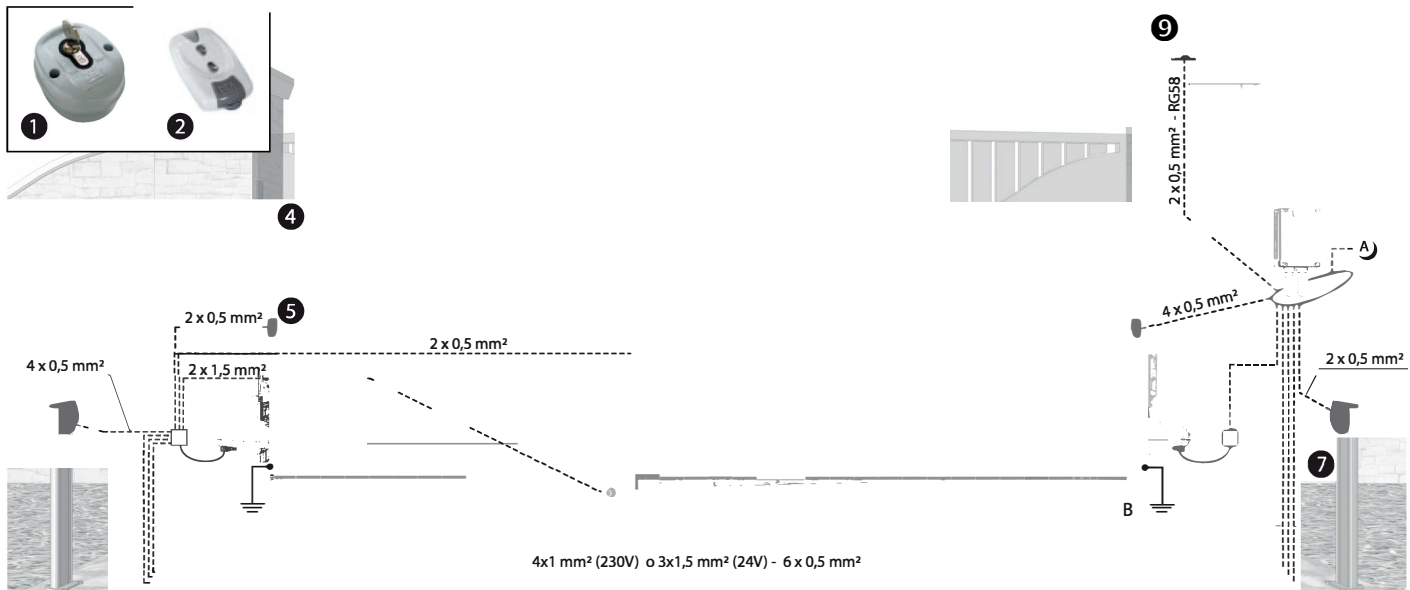

**A)** Make the 230V ± 10% 50-60 Hz mains connection using an omnipolar switch or any other device that guarantees the omnipolar disconnection of the mains network with a contact opening distance of 3 mm

All metal parts must be grounded

1

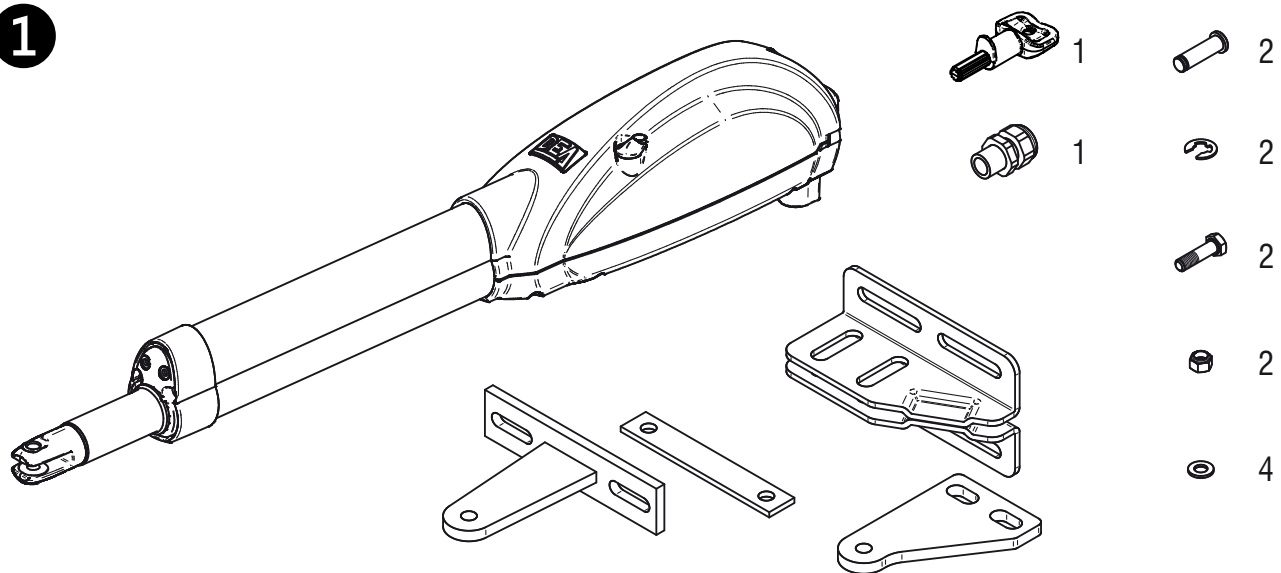

2

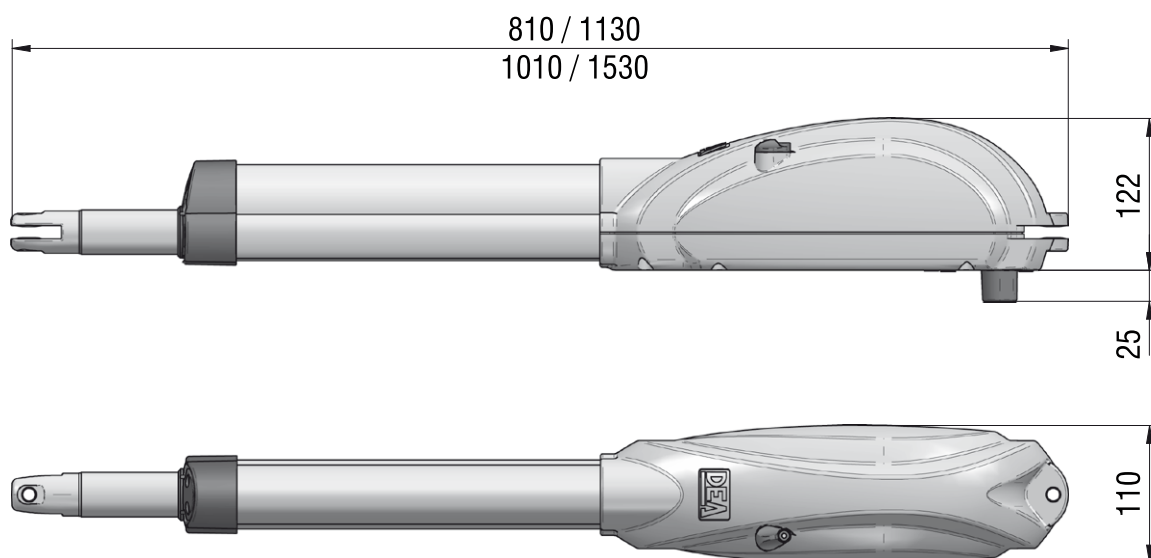

3

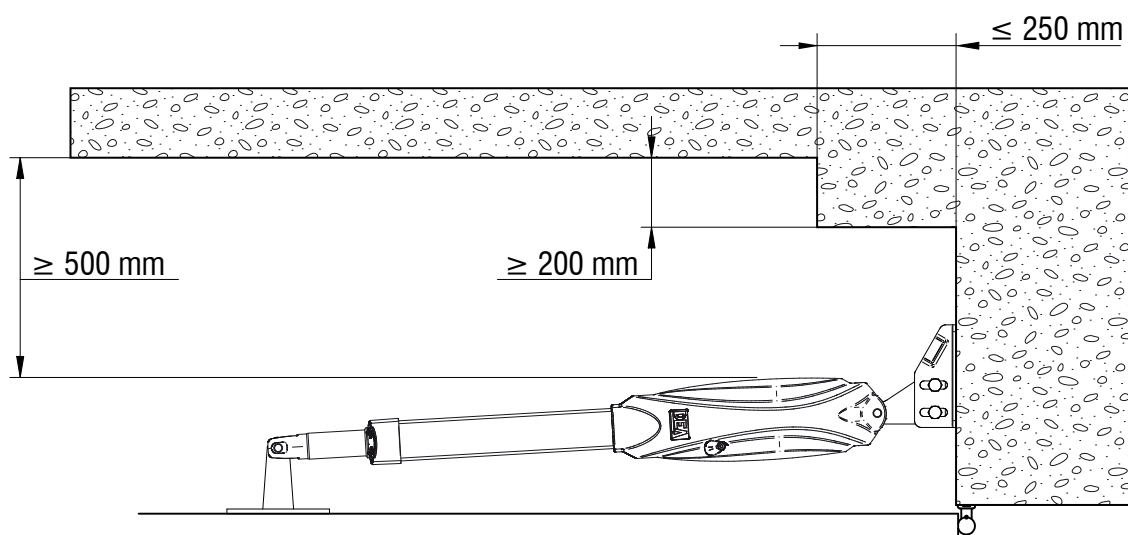



4

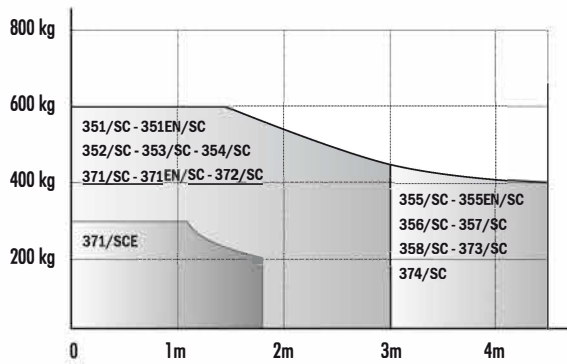

**WARNING** Non self-locking models, with same leaf length, reduce gate weight by 30% from number seen in "Length-weight" chart.

**WARNING** If the leaf is more than 2m long an electric-lock must be installed to hold the gate in closing position (non self-locking models).

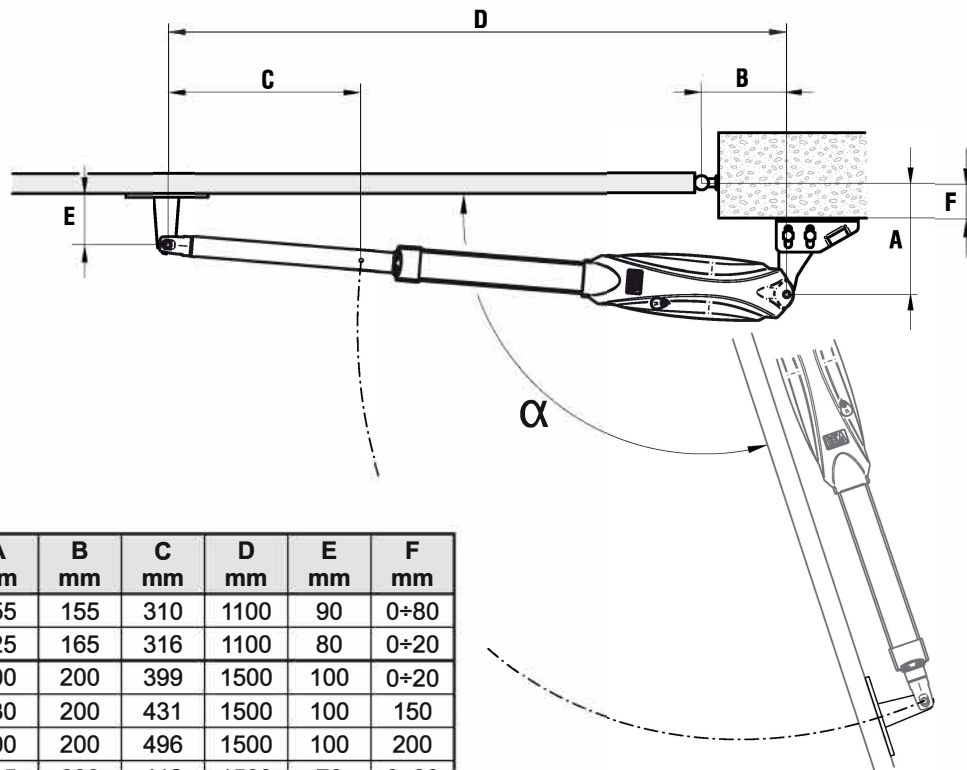

Model	$\alpha$	A mm	B mm	C mm	D mm	E mm	F mm
320	90°	155	155	310	1100	90	0+80
	100°	125	165	316	1100	80	0+20
520	90°	200	200	399	1500	100	0+20
		230	200	431	1500	100	150
	120°	290	200	496	1500	100	200
		135	200	418	1500	70	0+20

5

**WARNING** In case the operator is subjected to intense use or to move heavy gates, it is recommended to weld the rear bracket as shown in picture "A" so to ensure a longer product life.

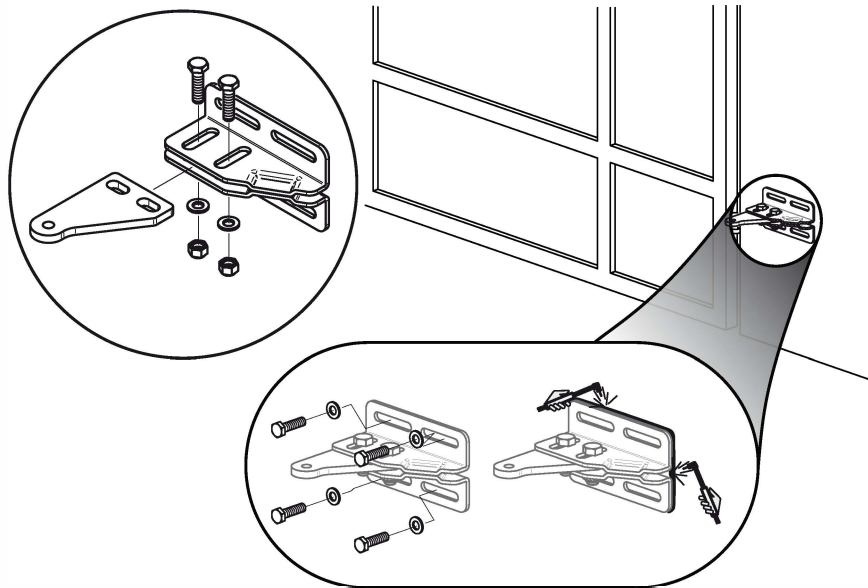
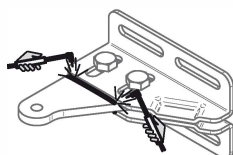
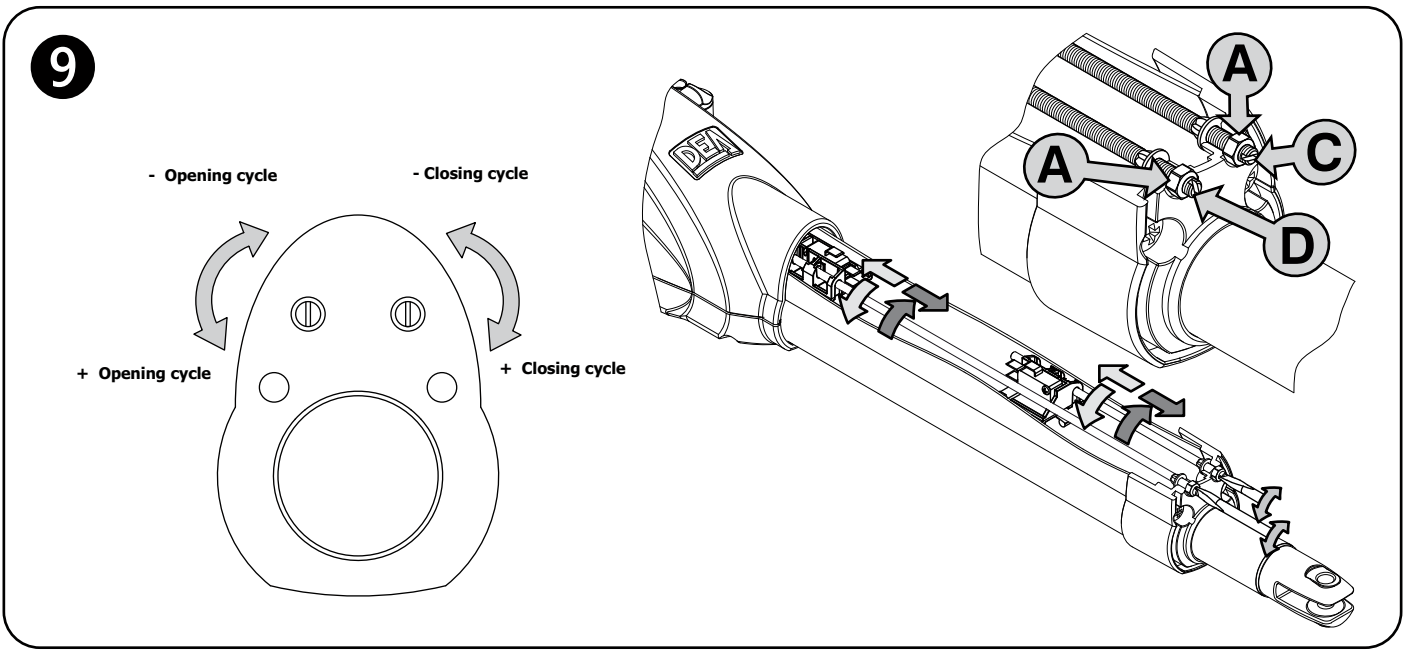
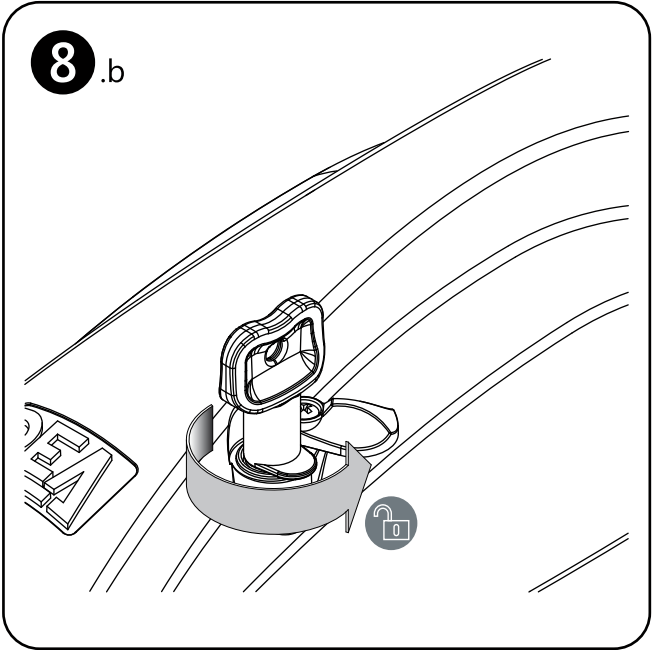
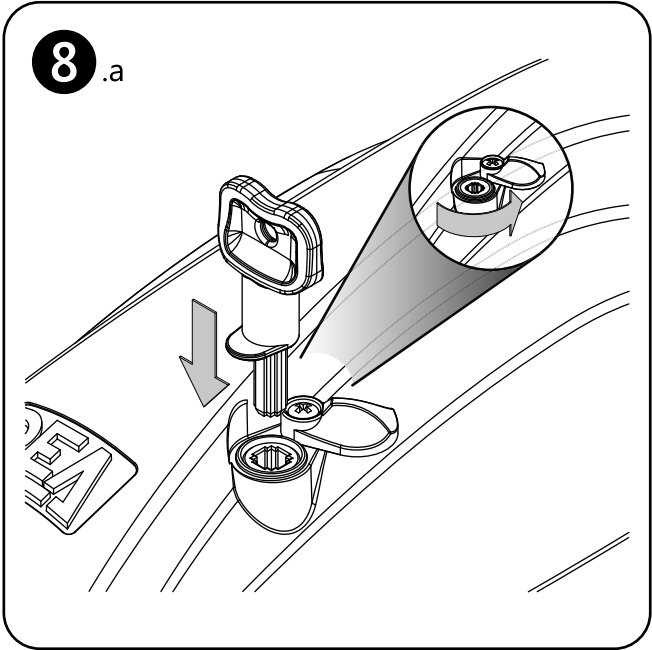
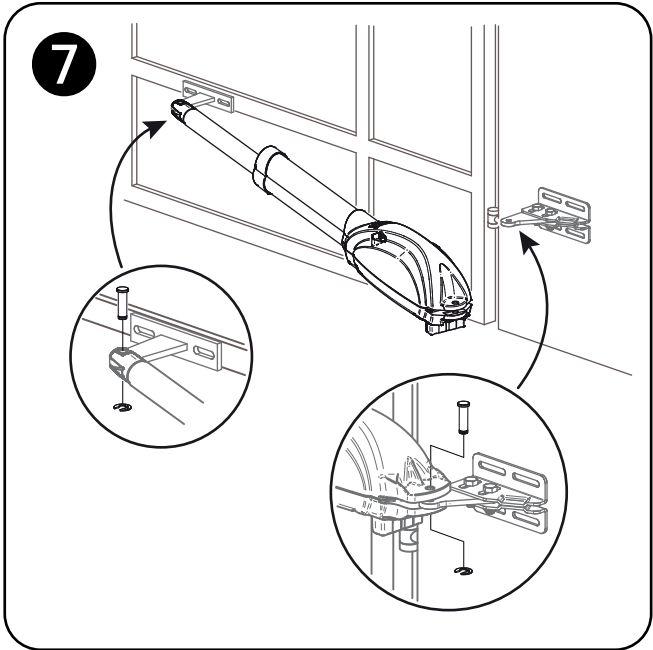
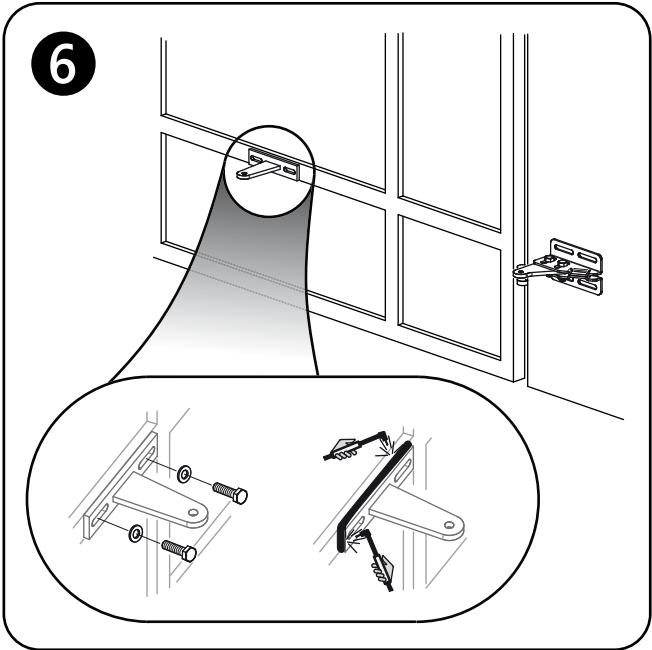
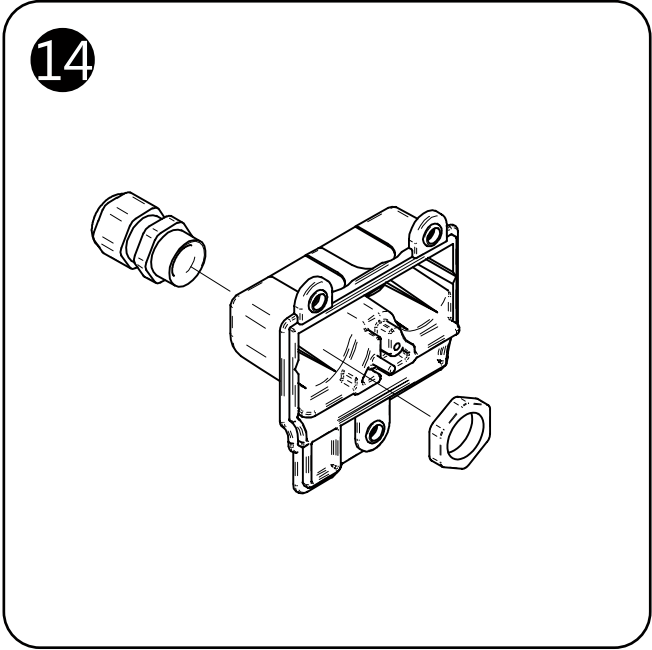
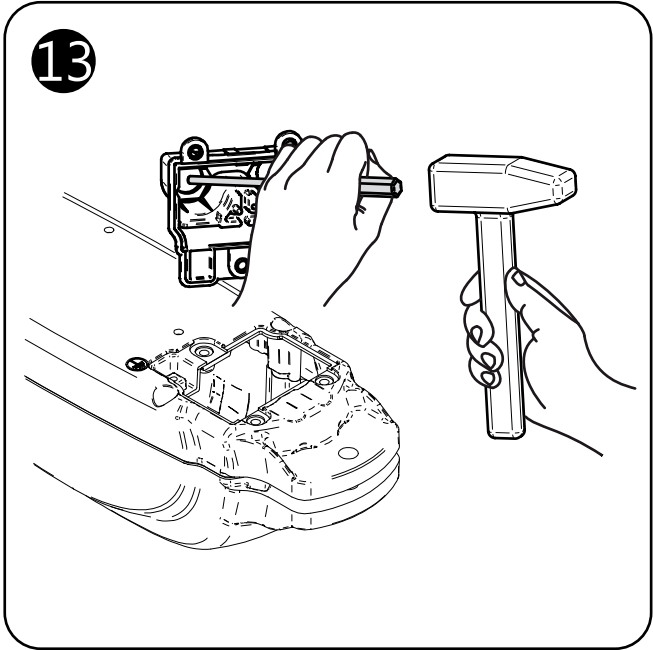
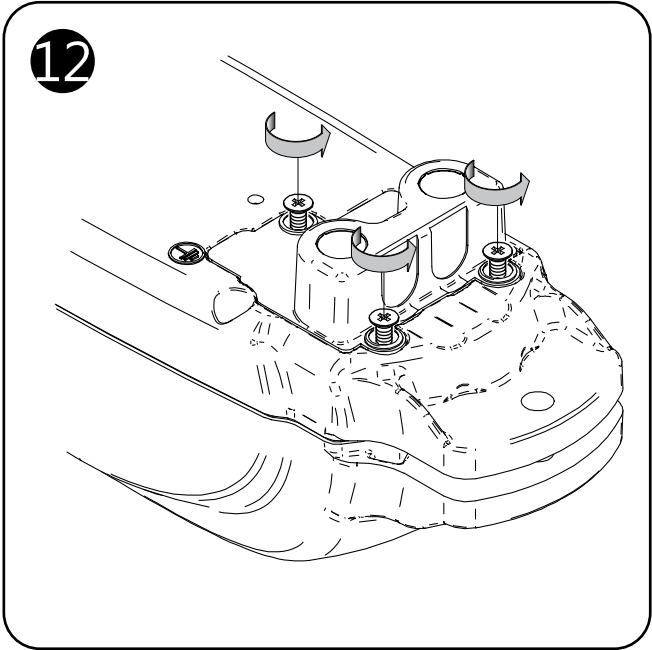
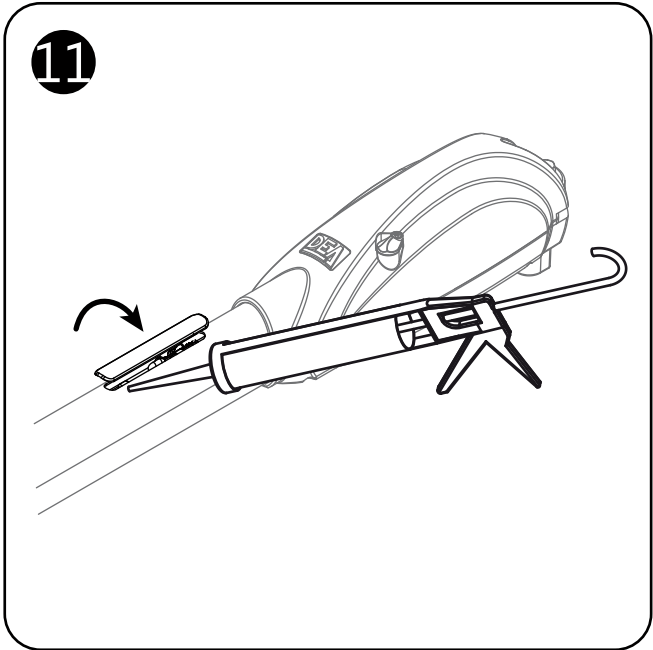
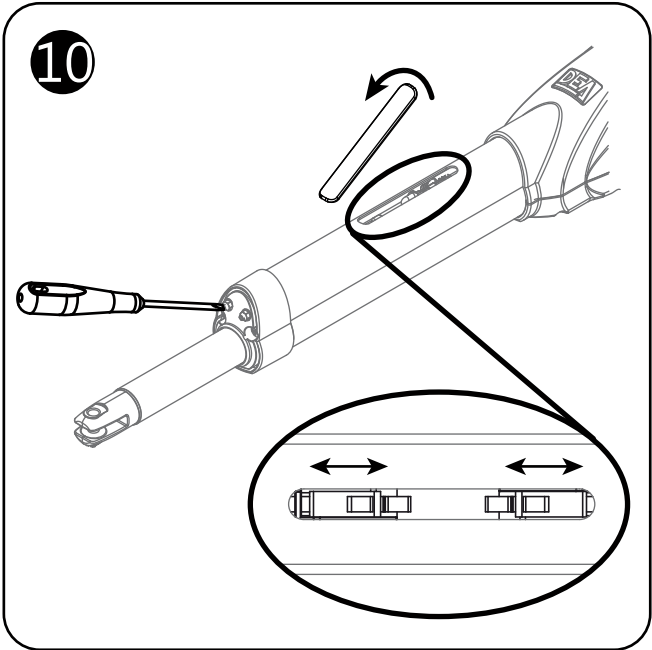

Fig. A







15





230V

4x1 mm<sup>2</sup>

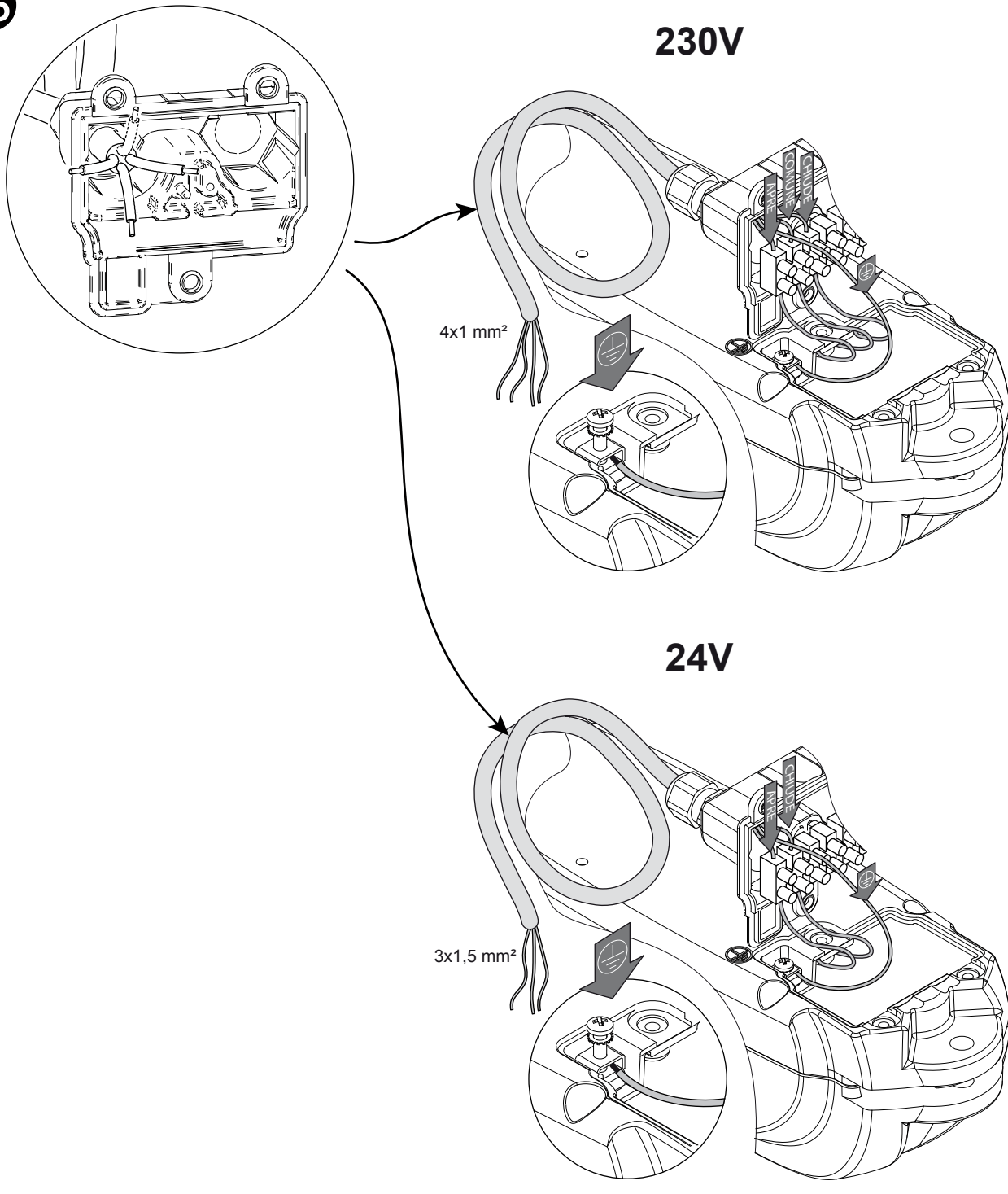
24V

3x1,5 mm<sup>2</sup>



Article Code	<i>ACCESSORIES</i>	
CS320 629340		Rod cover stroke 320/520 mm
CS520 629341		
MAC-LOOK/P 629320		Extension for MAC and LOOK rams
LOOK/SB 629380		Adapter kit for doors in slope. <b>Max gradient 8%</b>
COL 515 629250		Anti-falling stainless steel cable with 2 holes for swing doors

## INSTRUCTIONS FOR THE FINAL USER

This guide has been prepared for the final users of the automatism; the installer is required to deliver this guide and illustrate its contents to the person in charge of the system. The latter must then provide similar instruction to all the other users. These instructions must be carefully conserved and easily available for consultation when required.

Good preventive maintenance and frequent inspection ensures the long working life of the product. Contact the installer regularly for routine maintenance and in event of anomaly.

### SAFETY RULES

1. Always keep a safe distance from the automatism during operation and never touch any moving part.
2. Prevent children from playing near the automatism.
3. Perform the control and inspection operations prescribed in the maintenance schedule and immediately stop using the automatism whenever signs of malfunction are noted.
4. Never disassemble parts of the product! All maintenance and repair operations must be performed only by qualified personnel.
5. The release operation must sometimes be performed in emergencies! All users must be instructed on the use of the release mechanism and the location of the release keys.

### LOOK RELEASE MECHANISM

All LOOK models are equipped with a release device which must be operated as follows:

1. **Disconnect the power supply;**
2. Turn the cap placed on the back of LOOK in order to discover the underlying shaped hole;
3. Insert the release key inside the shaped hole paying attention to the direction of insertion (Fig. 8.a).
4. Rotate 90 degrees (counterclockwise to unlock, clockwise to lock ) the release key (Fig. 8.b);
5. At this point LOOK is released and if no other obstructions are present, the gate is free to move;
6. The opposite procedure returns LOOK operator to normal working conditions;
7. Remember to protect the lock with the respective cover so that the operator is protected by water or powder (even when it remains unlocked for a long time).

**WARNING:** During this operation gate may present uncontrolled movement: operate with extra care so to avoid any risk.

### CLEANING AND INSPECTIONS

The only operation that the user can and must do is to remove branches, leaves, and any other object that might obstruct the gate's free movement. Warning! Always disconnect the power supply whenever performing operations on the gate!

### TERMS OF WARRANTY

Our products are covered by warranty for 36 months from the date of installation. Coverage is limited exclusively to the free repair or replacement of parts recognised as defective. Warranty coverage will not be provided whenever the products have been tampered with, modified or installed incorrectly or whenever the identification labels with the respective codes and production dates are missing.

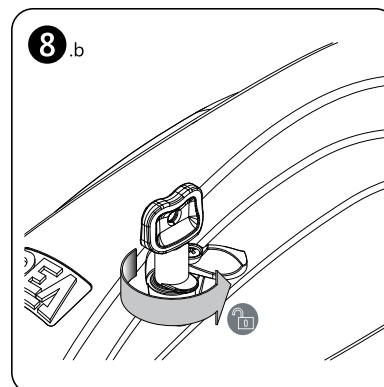
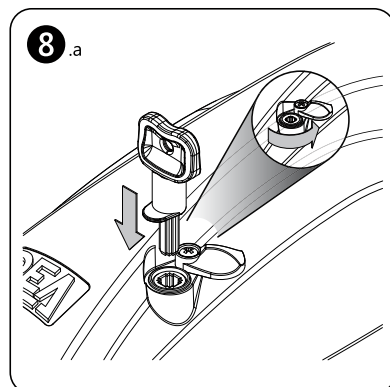

**DEA**<sup>®</sup>  
move as you like

DEA SYSTEM S.p.A. - Via Della Tecnica, 6 - ITALY  
36013 PIOVENE ROCCHETTE (VI)

tel. +39 0445 550789 - fax +39 0445 550265

Internet <http://www.deasystem.com> - e-mail: [deasystem@deasystem.com](mailto:deasystem@deasystem.com)