

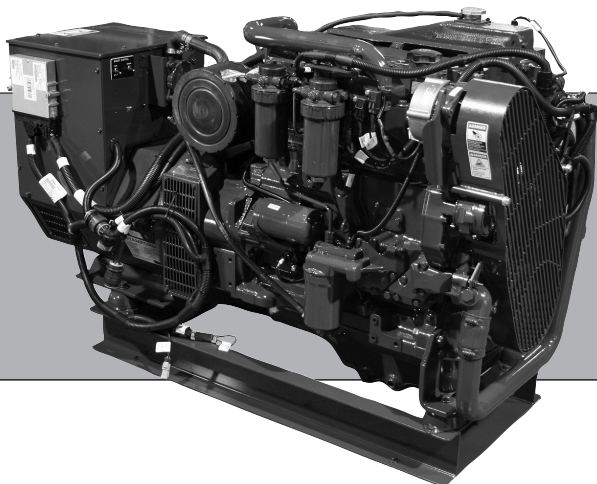

# OPERATOR'S MANUAL

## OM-C3

For Models: M50C13, M80C13, M65C13,  
M99C13, M120C13 and M150C13



[www.northern-lights.com](http://www.northern-lights.com)



— CALIFORNIA —  
Proposition 65 Warning:

**Breathing Diesel engine exhaust and some of its constituents are known to the State of California to cause cancer, birth defects, and other reproductive harm.**

- \* Always start and operate the engine in a well-ventilated area.
- \* If in an enclosed area, vent the exhaust to the outside.
- \* Do not modify or tamper with the exhaust system.
- \* Do not idle the engine except as necessary.

**For more information, go to [www.P65warnings.ca.gov/diesel](http://www.P65warnings.ca.gov/diesel).**

**Northern Lights**

4420 14th Avenue N.W.  
Seattle, WA 98107  
Tel: (206) 789-3880  
Fax: (206) 782-5455

Copyright ©2013 Northern Lights, Inc.  
All rights reserved. Northern Lights™, and  
the Northern Lights logo are trademarks of  
Northern Lights, Inc.

Printed in U.S.A.  
PART NO.: OM-C3 11/21



# OPERATOR'S MANUAL

for Northern Lights® M50C13, M65C13, M80C13,  
M99C13, M120C13 and M150C13

*Read this operator's manual thoroughly before starting to operate your equipment.  
This manual contains information you will need to run and service your new unit.*

## Table of Contents

<b>INTRODUCTION</b> .....	2	<b>COOLANT</b>	
Model Numbers.....	2	Engine Coolants.....	25
Serial Numbers .....	2	Water Quality for Mixing with Coolant Concentrates .	25
<b>WARRANTY</b> .....	3	Freeze Protection .....	26
<b>SAFETY RULES</b> .....	3 - 7	Operating in Warm Temperature Climates .....	26
Lockout / Tag Out Procedures .....	8	<b>SERVICE AND MAINTENANCE</b>	
<b>COMPONENT LOCATIONS</b>		Service and Maintenance Chart.....	27
M65C13 .....	10	Service and Maintenance - Daily .....	28-30
M99C13 .....	11	Service and Maintenance - 250 Hrs ....	31-35
<b>S-3B CONTROL PANEL (Optional)</b> .....	12	Service and Maintenance - 500 Hrs ....	36-45
<b>ENGINE OPERATION</b>		Service and Maintenance - 2000 Hrs ..	46-52
Normal Engine Operation .....	13	Service and Maintenance - As Required ..	53-62
Break-In Procedure.....	14	<b>ENGINE LAYOUT</b> .....	63
Marine Break-In Service .....	14	<b>LONG TERM STORAGE</b> .....	64-65
Break-In Oil .....	14-15	<b>TROUBLESHOOTING</b>	
Break-In Service .....	15-16	Engine Troubleshooting .....	66-70
Generator Power Set Units .....	17	Electrical Troubleshooting.....	71
Auxiliary Gear Drive Limitations.....	17	<b>SPECIFICATIONS</b> .....	72-73
Starting the Engine .....	18	<b>WIRING DIAGRAMS</b>	
Cold Weather Operation .....	18	AC Wiring Diagrams .....	74-75
Electronic Control Unit Connections .....	19	DC Wiring Diagrams .....	76-78
<b>LUBRICATION</b>		<b>APPENDIX (Non-Current Production Diagrams)</b>	
Diesel Fuel .....	20	AC Wiring Diagrams .....	79
Required Fuel Properties.....	20		
Supplemental Diesel Fuel Additives.....	21		
Lubricity of Diesel Fuel.....	21		
Handling and Storing Diesel Fuels.....	21		
Biodiesel Fuel .....	22-24		
Oil and Filter Service Intervals .....	24		
Lubricant Storage.....	24		
Oil Filters.....	24		

### Proprietary Information

This publication is the property of Northern Lights, Inc.

It may not be reproduced in whole or in part without the written permission of Northern Lights, Inc.

© Northern Lights, Inc. All rights reserved. Litho U.S.A. Publication number OM-C3 11/21

---

## Introduction

---

Servicing of marine engines and generator sets presents unique problems. In many cases boats cannot be moved to a repair facility. Marine engines cannot be compared to the servicing of automobiles, trucks or even farm equipment. Failures often occur in remote areas far from competent assistance. Marine engines are taxed far more severely than auto or truck engines; therefore, maintenance schedules must be adhered to more strictly.

Failures begin with minor problems that are overlooked and become amplified when not corrected during routine maintenance.

As operator, it is your obligation to learn about your equipment and its proper maintenance. This is not a comprehensive technical service manual. Nor will it make the reader into an expert mechanic. Its aim is to aid you in maintaining your unit properly.

---

## Model Numbers

---

- M50C13** = 50 kW Northern Lights® commercial marine generator set with a John Deere Powertech Tier III 6068 engine block and an electronically controlled fuel system.
- M65C13** = 65 kW Northern Lights® commercial marine generator set with a John Deere Powertech Tier III 6068 engine block and an electronically controlled fuel system.
- M80C13** = 80 kW Northern Lights® commercial marine generator set with a John Deere Powertech Tier III 6068 engine block and an electronically controlled fuel system.
- M99C13** = 99 kW Northern Lights® commercial marine generator with a John Deere Powertech Tier III 6068 engine block and an electronically controlled fuel system.
- M120C13** = 120 kW Northern Lights® commercial marine generator with a John Deere Powertech Tier III 6068 engine block and an electronically controlled fuel system.
- M150C13** = 150 kW Northern Lights® commercial marine generator with a John Deere Powertech Tier III 6068 engine block and an electronically controlled fuel system.

---

## Serial Numbers

---

When referencing Northern Lights equipment by serial number, please refer only to the number stamped on the Northern Lights® serial number plate.

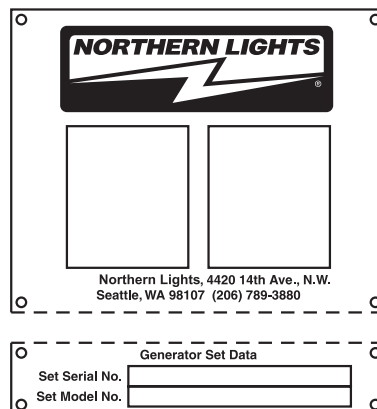
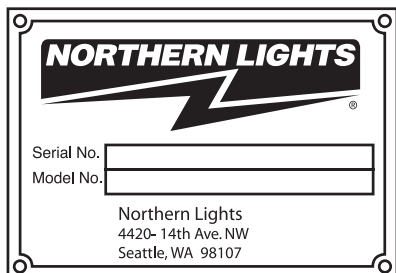



---

## Warranty

---

A warranty registration certificate is supplied with your set. The extent of coverage is described in the Limited Warranty Statement. We recommend that you study the statement carefully.

NOTE: If the warranty is to apply, the servicing instructions outlined in this manual must be followed. If further information is needed, please contact an authorized dealer or the factory.

---

## Safety Rules

---



**NOTICE:** Accident reports show that careless use of engines causes a high percentage of accidents. You can avoid accidents by observing these safety rules. Study these rules carefully and enforce them on the job.

### IMPORTANT SAFETY INSTRUCTIONS.



Electromagnetic equipment, including generator sets and their accessories, can cause bodily harm and life threatening injuries when improperly installed, operated or maintained. To prevent accidents be aware of potential dangers and act safely.



READ AND FOLLOW ALL SAFETY INSTRUCTIONS IN THIS MANUAL, PRIOR TO THE INSTALLATION OF ANY GENERATOR SET OR ACCESSORY. KEEP THESE INSTRUCTIONS FOR FUTURE REFERENCE.

### Recognize Safety Symbols and Instructions

In addition to the information found in this section, this operator's manual uses three different signal words to outline potential dangers of a specific nature.

 <b>DANGER</b>	DANGER indicates a hazardous situation which, if not avoided, will result in death or serious injury.
 <b>WARNING</b>	WARNING indicates a hazardous situation which, if not avoided, could result in death or serious injury.
 <b>CAUTION</b>	CAUTION indicates a hazardous situation which, if not avoided, could result in minor or moderate injury.

### Follow All Safety Instructions

Carefully read and understand all safety messages in this manual and on your machine's safety signs. Keep signs in good and clean condition. Replace missing or damaged signs. Be sure new equipment components and repair parts include the current safety signs. For replacement signs, proper placement of safety signs or clarification on any safety issue, consult your Northern Lights dealer or the factory. There can be additional safety information contained



on parts and components from outside suppliers that is not reproduced in this manual. Consult the suppliers for additional safety information.

Learn how to operate the machine and how to use the controls properly. Only trained personnel should operate machines, or work on or around them.

Keep you machine in proper working condition. UNAUTHORIZED MODIFICATIONS TO THE MACHINERY MAY IMPAIR ITS FUNCTION AND SAFETY PARAMETERS.

### Prevent Bypass and Accidental Starting

#### **WARNING**

Do not start engine by shorting across start terminal. Engine will start if normal circuitry is bypassed, creating a hazard by runaway machinery.



Start engine only from operator's station.

### Handle Fuel Safely - Avoid Flames

#### **WARNING**

Diesel is highly flammable and should be treated with care at all times. Do not refuel while smoking or when near sparks or open flame.

ALWAYS STOP ENGINE BEFORE FUELING MACHINE. Always fill portable fuel tank outdoors. Never fuel a hot engine.



## Safety Rules (Continued)

Prevent accidental discharge of starting fluids by storing all cans in a cool, safe place, away from sparks or open flame. Store with cap securely on container. Never incinerate or puncture a fuel container.

Prevent fires by keeping machine clean of accumulated trash, grease and debris. Always clean any spilled fuel as swiftly as possible. Do not store oily rags, which can ignite and burn spontaneously.

Be prepared if a fire starts. Keep a first aid kit and fire extinguisher handy. Keep emergency contact numbers for fire department, doctors, ambulance and hospital near the telephone.

### Service Machines Safely

#### **! DANGER**

Do not wear a necktie, scarf, necklace, rings or other jewelry, or any loose clothing when working near moving parts. Tie long hair behind your head. If any of these items get caught in moving machinery, severe injury or death could result.

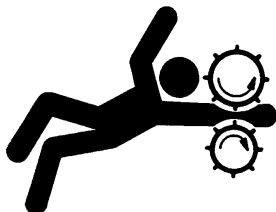

Check for any loose electrical connections or faulty wiring.

Look completely around engine to make sure that everything is clear before starting.

### Wear Protective Clothing

#### **! WARNING**

To prevent catching anything in moving machinery, always wear close fitting clothes and safety equipment appropriate to the job.

Prolonged exposure to loud noise can cause hearing loss or impairment.

Wear suitable authorized hearing protection, such as earmuffs or plugs to protect against loud noises

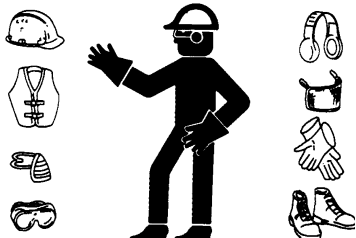

Operating equipment requires the full attention of the operator. Do not use radio or music headphones while operating machinery.

### Practice Safe Maintenance

#### **! CAUTION**

Understand all service procedures before starting work. Keep area clean and dry. Never lubricate, service, or adjust machine while it is in operation.



Keep hands, feet and clothing away from power-driven equipment. When shutting down an engine, disengage all power and operator controls. Allow the engine to cool completely before beginning any service work.

*Securely support any machinery elements that must be raised for service work with support or lifting machinery specifically intended for that purpose.*

Keep all parts in good conditions and properly installed. Fix damage immediately. Replace any worn or broken parts. Remove any build up of grease, oil or debris.

Disconnect battery ground cable (-) before making any adjustments or service work.

### Stay Clear of Rotating Drivelines

#### **! DANGER**

Entanglement in rotating drivelines can cause serious injury or death. Keep shields in place at all times. Make sure that rotating shields turn freely in pace with the drivelines.

Do not wear loose fitting equipment around rotating drivelines. Stop the engine and make sure that all moving parts have stopped before making any adjustments, connections, or performing any other type of service to the engine or other driven equipment.



## Safety Rules (Continued)

### Install all Safety Guards

#### **WARNING**

Direct contact with rotating fans, belts, pulley and drives can cause serious injury.

Keep all guards in place at all times during engine operation.

Wear close-fitting clothes. Stop the engine and be sure all fans, belts, pulleys and drives are stopped before making adjustments, connections, or cleaning near fans and their components.

Do not allow anything on your person to dangle into or come in contact with a moving fan, belt, pulley or drive. Fans can act as vacuums and pull materials up from below, so avoid that area as well while in service.

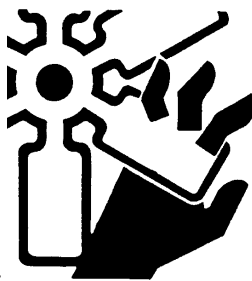

### Safe Battery Handling

#### **WARNING**

#### Prevent Battery Explosions

Battery gas is highly flammable. Battery explosions can cause severe injury or death. To help prevent battery explosions, keep sparks, lighted matches and open flame away from the top of battery. When checking battery electrolyte level, use a flashlight.

Never check battery charge by contacting the posts with a metal object. Use a volt-meter or hydrometer.

Frozen batteries may explode if charged. Never charge a battery that has not been allowed to warm to at least 16°C (60°F).

Always remove grounded (-) battery clamp first and replace ground clamp last.

Sulfuric acid in battery electrolyte is poisonous and strong enough to burn skin, eat holes into clothing and other materials, and cause blindness if splashed into eyes.



### To Avoid Hazards:

- Fill batteries only in well-ventilated areas.
- Wear appropriate eye protection and rubber gloves.
- Never use air pressure to clean batteries.
- Wear appropriate ventilation equipment to avoid inhaling fumes when adding electrolyte.
- Do not spill or drip electrolyte.
- Use correct jump-start procedure if required.

### If acid is spilled on skin or in eyes:

1. Flush skin with water.
2. Apply baking soda or lime to help neutralize acid.
3. Flush eyes with water for 15-30 minutes.
4. Get medical attention immediately.

### If acid is swallowed:

1. DO NOT induce vomiting.
2. Drink large amounts of water or milk, without exceeding 2 liters (2 quarts)
3. Get medical attention immediately

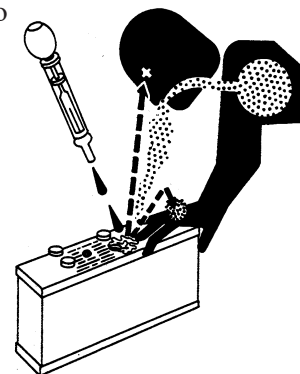

#### **WARNING**

Battery posts, terminals, and related accessories can contain lead and lead compounds, chemicals known to the State of California to cause cancer and reproductive harm. Wash hands after handling.

### Handle Chemical Products Safely

#### **WARNING**

Direct exposure to hazardous chemicals can cause serious injury. Among the potentially hazardous chemicals that may be used with Northern Lights products are lubricants, coolants, paints and adhesives.

All potentially hazardous chemicals come with a Material Safety Data Sheet (MSDS). The MSDS provides specific details on chemical products, including physical hazards, safety procedures and emergency response techniques



## Safety Rules (Continued)

Read and understand the MSDS for each chemical before you start any job that includes it. Follow the procedures and use appropriate equipment exactly as recommended.

Contact your Northern Lights dealer or Northern Lights factory for MSDS's used on Northern Lights products.

### Work in Well Ventilated Areas

#### **! CAUTION**

Exhaust fumes from engines contain carbon monoxide and can cause sickness or death. Work in well ventilated areas to avoid prolonged exposure to engine fumes. If it is necessary to run an engine in an enclosed area, route the exhaust fumes out of the area with an approved, leak proof exhaust pipe extension.

### Remove Paint Before Welding or Heating

#### **! WARNING**

Hazardous fumes can be generated when paint is heated by welding, soldering or using a torch. To avoid potentially toxic fumes and dust, remove paint before heating.

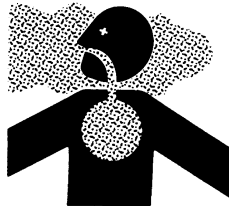

- Remove paint a minimum of 100 mm (4 in.) from the area that will be affected by heat.
- If paint cannot be removed, wear an approved respirator.
- If you sand or grind paint, use an approved respirator.
- If you use solvent or paint stripper, remove stripper with soap and water before welding. Remove solvent or paint stripper containers from the area.
- Allow at least 15 minutes for fumes to disperse before welding or heating.

Do not use a chlorinated solvent in an area where welding will occur. Work only in areas that are well ventilated. Dispose of paint and solvent properly.

### Service Cooling System Safely

#### **! WARNING**

Opening a pressurized cooling system can release explosive fluids and causing serious burns. Before opening any pressurized cooling system, make sure the



engine has been shut off. Do not remove a filler cap unless it is cool enough to comfortably grip with bare hands. Slowly loosen cap to relieve pressure before opening fully.

### Avoid High Pressure Fluids

#### **! WARNING**

Relieve pressure prior to disconnecting pressurized lines. Escaping fluid under pressure can penetrate the skin causing serious injury. Always relieve pressure before disconnecting hydraulic or other pressurized lines. Tighten all connections firmly before re-applying pressure.



If searching for leaks, use a piece of cardboard. Always protect your hands and other body parts from high-pressure fluids.

If an accident occurs, see a doctor immediately. Any high pressure spray injected into the skin must be removed within a few hours to prevent the risk of gangrene or other infection.

### Avoid Heating Near Pressurized Fluid Lines

#### **! WARNING**

Flammable spray can be generated by heating near pressurized fluid lines, resulting in severe burns and bodily injury. Pressurized lines can rupture when heat goes beyond the immediate flame area. Do not weld, solder or use a torch or open flame near pressurized lines or other flammable fluids.



### Do Not Open High-Pressure Fuel System

#### **! DANGER**

Many Northern Lights engines use high-pressure fuel injection. High-pressure fluid remaining in fuel lines can cause serious injury. Do not disconnect or attempt any repair of fuel lines, sensors, or other

## Safety Rules (Continued)

components between the high-pressure fuel pump and nozzles on engines with high pressure fuel systems.



**ONLY AUTHORIZED TECHNICIANS CAN PERFORM REPAIRS ON AN HIGH PRESSURE FUEL INJECTION SYSTEMS.**

### Avoid Hot Exhaust



Avoid exposure to and physical contact with hot exhaust gases. Exhaust parts and streams can reach high temperatures during operation, leading to burns or other serious injury.



Cleaning exhaust filters can also lead to exposure to hot exhaust gas and the injury risk associated with it. Avoid exposure to and physical contact with hot exhaust gases when cleaning exhaust filters.

During auto or manual/stationary exhaust filter cleaning operations, the engine will run at elevated temperatures for an extended period of time. Exhaust parts and streams can reach high temperatures during operation, leading to burns or other serious injury.

### Avoid Harmful Asbestos Dust



Inhaling asbestos fibers may cause lung cancer. Avoid breathing dust that may be generated when handling components containing asbestos fibers, including some gaskets.

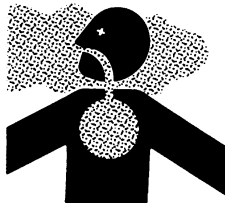

The asbestos used in these components is usually found in a resin or otherwise sealed. Normal handling of these components is not dangerous, as long as airborne dust containing asbestos is not generated.

Avoid creating dust. Never use compressed air for cleaning. Avoid brushing or grinding materials containing asbestos. When servicing, wear an approved respirator. A special vacuum cleaner is recommended to clean asbestos. If this vacuum is not available, apply a mist of oil or water on the

material containing asbestos. Keep all bystanders away from any area where asbestos dust may be generated.

### Use Proper Lifting Equipment and Techniques



Lifting heavy components incorrectly can cause severe injury or damage to machinery. Avoid unbalanced loads. Do not use lifting eyes. Lift the generator set using lifting bars inserted through the lifting holes on the skid. Follow all recommended removal and installation procedures in this and associated Northern Lights manuals.

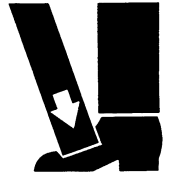

### Use Proper Tools



Makeshift tools and procedures can create safety hazards. Always use appropriate tools for the job.



Use power tools only to loosen threaded parts and fasteners. For loosening and tightening hardware, always use the correct sized tools.

Do not use US measurement tools on metric fasteners, or vice versa. Use only service parts that meet Northern Lights specifications.

### Dispose of Waste Properly



Disposing of waste improperly can threaten the environment and lead to unsafe working conditions. Potentially harmful waste used in Northern Lights equipment can include oil, fuel, coolant, filters and batteries.

Use leakproof containers to drain fluid. Do not use food or beverage containers that may mislead someone into drinking from them.

Do not pour waste onto the ground, down a drain or into any water source.



## Lock Out / Tag Out Procedures

### Scope

During maintenance, repairs or retooling of a Northern Lights generator set, simply turning the machine off or unplugging it while it is being worked on does not give enough protection to others who are not performing the maintenance or repair. Many serious accidents happen when someone thought the machine was turned off, or all of its energy was safely blocked or released.

### General Policy

#### **⚠ CAUTION**

To avoid dangerous or hazardous situations, refrain from any of the following:

- Removing or bypassing a guard or other safety device
- Placing any part of your body in a position where you could be caught by moving machinery.
- Cleaning or oiling machinery when in operation.
- Adjusting circuits, chillers, pumps, air handlers, valves, circuit breakers or fans while in operation.
- Working on piping or high pressure systems.

### Lock Out/Tag Out Instructions - Electrical Equipment

#### **⚠ WARNING**

Be sure the equipment's ON/OFF switch is in the OFF position and is unplugged from any electrical source before attempting to perform any type of work on the equipment. Obtain an electrical plug cap cover with a lockset. Secure the plug terminal end using the electrical plug lockout cap. Lock the cap and retain the key.

If the equipment is directly wired into an electrical box with a shut off switch, obtain a lock pad and/or the appropriate colored tags and place the lock and tag through the shut off lever. Retain the key until the repair is completed and the machine is safe to start. Be certain the shut off lever is in the OFF position before restarting. NEVER give a lock out key to unauthorized personnel.

If the equipment is directly wired into an electrical box without a shut off switch and lock out capability, then a circuit breaker lock out will be required. Obtain a circuit lock and tag set. Install the lock onto the circuit breaker box. Ensure the unit ON/OFF switch is in the OFF position before restarting.

### Lock Out/Tag Out Instructions - Pneumatic and Hydraulic Equipment

#### **⚠ WARNING**

For servicing pneumatic and hydraulic equipment, the following additional procedures must be implemented, following completion of lock out/tag out procedures for the unit to be serviced:

Shut off air, water or supply valves at the equipment to be serviced.

Check the local bleed-off point for completed release of pressurized air, water or oil.

If shutting off of air, water or other material cannot be achieved at the local supply valve, shut off valves further back in the system and re-check the bleed-off point until complete shut-off is achieved.

Affix a DO NOT OPERATE tag to each valve handle that requires shut off. Each DO NOT OPERATE tag must be signed and dated by the authorized technician servicing the equipment.

### Lock Out/Tag Out Instructions - Air Hose Connected Pneumatic Equipment

#### **⚠ WARNING**

Equipment connected to the compressed air system through an air hose with a detachable fitting must be shutdown and unplugged. Excess air must be bled prior to removing the air hose, prior to any maintenance or repair activities.

Affix a DO NOT OPERATE tag to the air hose near the detachable fitting. Each DO NOT OPERATE tag must be signed and dated by the authorized technician servicing the equipment. Check that the equipment cannot be operated by activating the ON switch.

### Stored Energy

#### **⚠ WARNING**

Immediately after applying Lock Out or Tag Out devices, ensure that all potentially hazardous stored or residual energy is relieved, disconnected, restrained and otherwise rendered safe.

### Verification of Isolation

#### **⚠ CAUTION**

Verify the machinery or equipment is actually isolated and de-energized prior to beginning work on a machine or on equipment that has been locked out.

### Restarting Procedures

#### **⚠ CAUTION**

Follow the procedures below prior to restoring energy:

- Ensure that all machinery or equipment is properly reassembled. Inspect the machinery or equipment to verify non-essential items have been removed.
- Ensure that all personnel are safely outside danger zones. Notify personnel that lock out/tag out devices have been removed and energy will be reapplied.
- Only authorized personnel may remove lock out/tag out devices or notices.

---

## Notes

---

## Component Locations

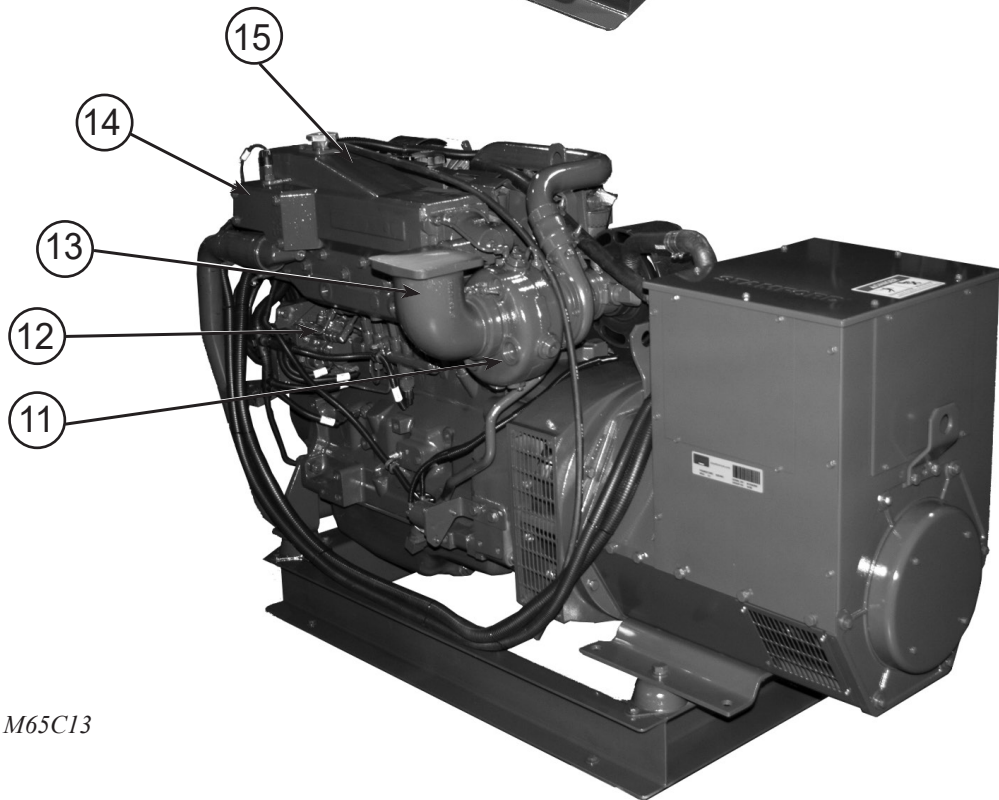
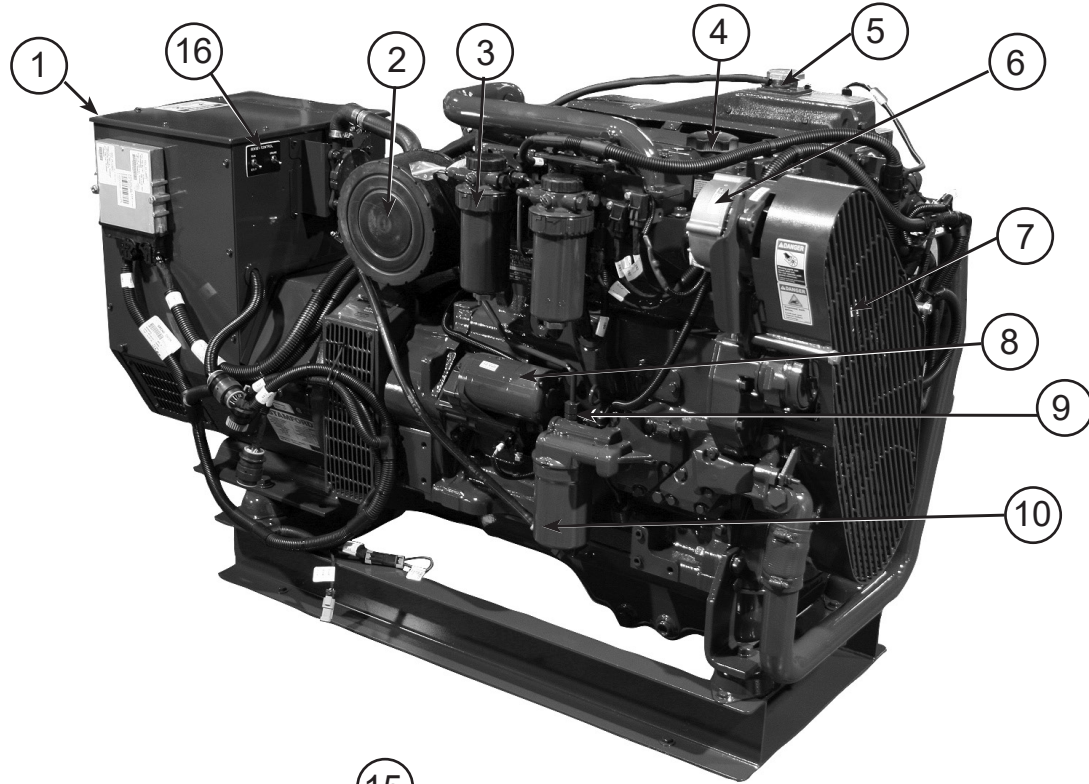

*Figures 1 & 2: M65C13*

- 1. Junction Box
- 2. Air Cleaner
- 3. Fuel Filter
- 4. Lube Oil Fill
- 5. Coolant Fill

- 6. Alternator
- 7. Belt Guard
- 8. Starter
- 9. Lube Oil Dipstick
- 10. Lube Oil Filter

- 11. Turbocharger
- 12. Fuel Injection Pump
- 13. Exhaust Elbow
- 14. Thermostat Cover
- 15. Expansion Tank
- 16. Stop / Start Panel



## Component Locations

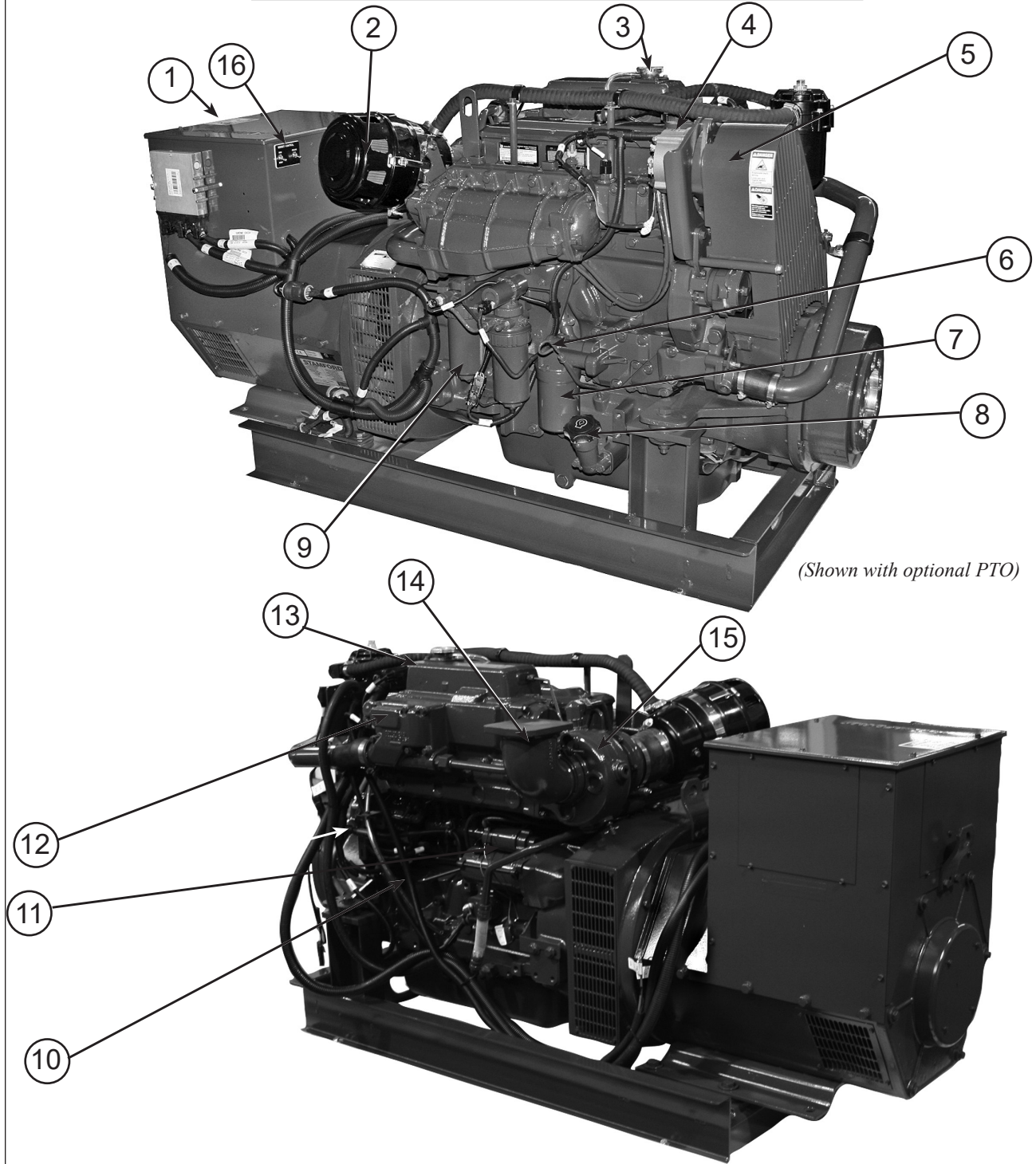

**Figure 3 & 4: M99C13**

- 1. Junction Box
- 2. Air Cleaner
- 3. Coolant Fill
- 4. Alternator
- 5. Belt Guard

- 6. Lube Oil Dipstick
- 7. Lube Oil Filter
- 8. Lube Oil Fill
- 9. Fuel Filter
- 10. Fuel Injection Pump

- 11. Starter
- 12. Thermostat Cover
- 13. Expansion Tank
- 14. Exhaust Elbow
- 15. Turbocharger
- 16. Stop / Start Panel

## SB Control Panel (Optional)



Figure 7: Series 3B Generator Control Panel

### 1. SHUTDOWN BYPASS SWITCH

Bypasses the safety shutdown feature during the starting process.

### 2. ENGINE CONTROL SWITCH

To start engine: hold Engine Control Switch in the START position until the engine is running.

NOTE: Excessive cranking of marine sets equipped with water lift muffler systems can cause engine damage.

After the engine starts, release the switch and it will return to RUN position. To stop the engine, hold the switch in the STOP position.

### 3. OIL PRESSURE GAUGE

Shows the oil pressure in the engine lubricating system. If the pressure drops below 15 PSI at a speed higher than idling, stop the engine and investigate.

### 4. COOLANT TEMPERATURE GAUGE

Indicates temperature of cooling water. If the gauge registers over 200°F (93.3°C) or drops below 140°F (60°C), stop the engine and investigate.

### 5. HOUR METER

Tracks engine running time.

### 6. DC VOLTMETER

Indicates the voltage output of the alternator (when engine is running).

---

## Engine Operation

---

### **NORMAL ENGINE OPERATION**

Observe engine coolant temperature and engine oil pressure. Temperatures and pressures will vary between engines and with changing operating conditions, temperatures, and loads. See GENERAL ENGINE SPECIFICATIONS on pages 74-75 of this manual for temperature and pressure specifications for your engine.

If coolant temperature rises above the maximum coolant temperature (see Specifications Section) reduce load on engine. Unless temperature drops quickly, stop engine and determine cause before resuming operation.

Operate the engine under a lighter load and at slower than normal speed for first 15 minutes after start-up. DO NOT run engine at slow idle unless necessary for maneuvering out of dock and harbor.

Stop engine immediately if there are any signs of part failure. Symptoms that may be early signs of engine problems are:

- Sudden drop in oil pressure
- Abnormal coolant temperatures
- High marine gear oil temperature
- Unusual noise or vibration
- Sudden loss of power
- Excessive black exhaust
- Excessive fuel consumption
- Excessive oil consumption
- Fluid leaks Break-In Service

---

## Engine Operation

---

### BREAK-IN PROCEDURE

During the 100 hour break-in period it is important to adequately work the engine to properly seat the engine components. Extended idle and light load operation should be minimized. Extended idle and/or light load operation intervals should not exceed 30 minutes during the break-in process. Minimum operating engine loads should be sufficient to result in coolant temperatures at or above the thermostat opening temperature.

**IMPORTANT: It is critically important to properly break in the engine within the first 100 hours. Attempting a break-in at higher hour intervals may be unsuccessful. To correctly perform the break-in, extra effort is required to ensure that engine is heavily exercised and may include running the engine harder than normal usage. This is especially true with lightly loaded applications such as trawlers and oversized generator sets.**

Constant Speed Applications — Minimum engine load factors during the break-in period should be greater than 30%.

It is recommended that the engine operate between 50% and 90% load greater than 50% of the time during the break-in period.

**IMPORTANT: Lightly Loaded Applications Post Break-In** - Engine break-in will not compensate for the observable conditions of a lightly loaded engine such as black fuel oil residue in the exhaust system. These conditions can be common among trawler propulsion engines, oversized generator sets, applications that spend long intervals at idle, and will occur on any lightly loaded diesel engine. Northern Lights marine diesel engines are designed to operate at loaded conditions. To prevent exhaust system contamination in a lightly loaded application, regularly exercise the engine by periodically increasing the load.

For example, in a trawler propulsion application underway increase the throttle to achieve an engine speed of the break-in speeds defined above for a minimum of 10 minutes every 3 hours. For a generator application, increase the load to 50% load for a minimum of 10 minutes every 3 hours.

Load factor - the actual fuel burned over a period of time divided by the full-power fuel consumption for the same period of time. For example, if an engine burns 160 L of fuel during an eight-hour run, and the full-power fuel consumption is 60 L per hour, the load factor is:  
 $160 \text{ L} / (60 \text{ hours per hour} \times 8 \text{ hours}) = 33.3\%$

### MARINE BREAK-IN SERVICE

A proper break-in procedure is critical with marine diesel engines. A proper break-in will ensure optimal engine life. A proper break-in for marine engines is expected to take approximately 100 hours if performed correctly.

For constant speed engine operation such as generators, a similar process should be followed, except instead of changing speed, the engine load should be increased until the point of maximum engine fueling (100% load or maximum generator output). These 10% steps in engine percent load should be performed for a minimum of 5—10 minutes each or until engine temperature stabilizes while monitoring all engine criticals. If a fault code should occur, abort process and review application and installation guidelines.

### BREAK-IN OIL

The engine is factory filled with Northern Lights Diesel Engine Break-In Oil. This is a special formulation of oil that is designated to aid with the proper break-in of engine components. If performed correctly, it is expected the break-in process will take 100 hours. During this process some make-up oil may be required. As it is not unusual for some oil consumption during the break-in process; it is critical that the oil level be frequently monitored during this process. If make up oil is required use only Northern Lights Diesel Engine Break-In Oil.

Following the 100 hour break-in process it is recommended that change of oil and filter should occur. If the break-in procedure has been followed and sufficient extended loading of the engine has occurred it is acceptable to proceed with normal oil changes as advised in this operator's manual. However, if during the first 100 hours of operation the engine has operated at periods of light loading and/or idle it is recommended that the oil should be drained and replaced with Northern Lights Diesel Engine Break-In Oil, and the oil filter should be changed and replaced with a new Northern Lights oil filter. Following this, the break-in procedure should continue for an additional 100 hours.

---

## Engine Operation

---

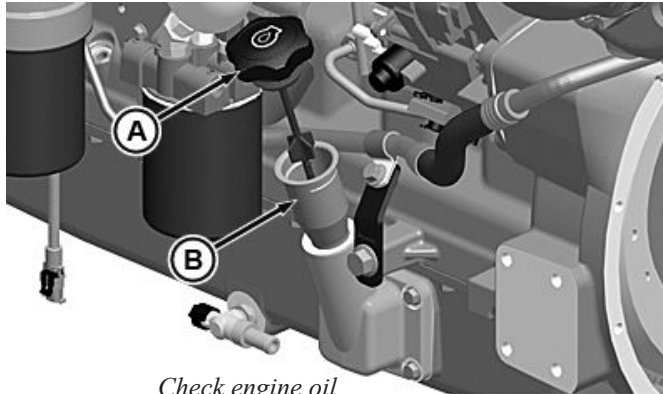

A- Engine oil dipstick

B- Dipstick tube

**IMPORTANT:** DO NOT fill above the top of the crosshatch pattern or the FULL mark, whichever is present.

Marine engines installed at an angle will have an alternate pattern as identified by the dipstick remarking process to compensate for installation angle.

Oil levels anywhere within crosshatch are considered in the acceptable operating range.

Northern Lights Break-In engine oil should be used to make up any oil consumed during the break-in period.

**IMPORTANT:** DO NOT use Plus-50 or Plus-50 II engine oil during the break-in period of a new engine or engine that has had a major overhaul. Plus-50 or Plus-50 II engine oil will not allow a new or overhauled engine to properly seat during the break-in period.

**IMPORTANT:** If Northern Lights Break-In or Break-In Plus engine oils are not available, use a SAE 10W-30 viscosity grade diesel engine meeting one of the following:

- API Service Classification CE
- API Service Classification CD
- API Service Classification CC
- ACEA Oil Sequence E2
- ACEA Oil Sequence E1

**IMPORTANT:** Do not use Plus-50 II, Plus-50, or engine oils meeting any of the following for the initial break-in of a new or rebuilt engine:

- API CJ-4
- API CI-4 PLUS
- API CI-4
- API CH-4
- API CG-4
- API CF-4
- API CF-2
- API CF
- ACEA E9
- ACEA E7
- ACEA E6
- ACEA E5
- ACEA E4
- ACEA E3

### BREAK-IN SERVICE

The engine is ready for normal operation. However, extra care during the first 100 hours of operation will result in more satisfactory long-term engine performance and life. DO NOT exceed 100 hours of operation with break-in oil. GENERAL ENGINE SPECIFICATIONS on pages 74-75 of this manual for oil pressure and coolant temperature specifications for your engine.

1. This engine is factory-filled with Northern Lights Engine Break-in Oil. Operate the engine at heavy loads with minimal idling during the break-in period.
2. If the engine has significant operating time at idle, constant speeds, and/or light load usage, or makeup oil is required in the first 100 hour period, a longer break-in period may be required. In these situations, an additional 100 hour break-in period is recommended using a new change of Northern Lights Engine Break-In Oil and a new Northern Lights oil filter.

**IMPORTANT:** DO NOT add makeup oil until the oil level is BELOW the ADD mark on dipstick. Northern Lights Engine Break-In Oil (TY26661) should be used to make up any oil consumed during the break-in period.

3. Check engine oil level more frequently during engine break-in period. If oil must be added during this period, Northern Lights Engine Break-In Oil is preferred. See ENGINE BREAK-IN OIL on page 14.

**IMPORTANT:** DO NOT use PLUS-50® Engine Oil during the break-in period of a new engine or engine that has had a major overhaul. PLUS-50 oil will not allow a new or overhauled engine to properly wear during this break-in period.



---

## Engine Operation

---

DO NOT fill above the crosshatch pattern (A) or the FULL mark, whichever is present. Oil levels anywhere within the crosshatch are considered in the acceptable operating range.

4. During the first 20 hours, avoid prolonged periods of engine idling. If engine will idle longer than 5 minutes, stop engine.

5. After the first 100 hours (maximum), change engine oil and replace engine oil filter (A). (See CHANGE ENGINE OIL AND FILTER in Lubrication and Maintenance/250 Hour Section.) Fill crankcase with seasonal viscosity grade oil. (See DIESEL ENGINE OIL, in Fuels, Lubricants, and Coolant Section.)

NOTE: Some increase in oil consumption may be expected when low viscosity oils are used. Check oil levels more frequently. If air temperature is below  $-10^{\circ}\text{C}$  ( $14^{\circ}\text{F}$ ), use an engine block heater.

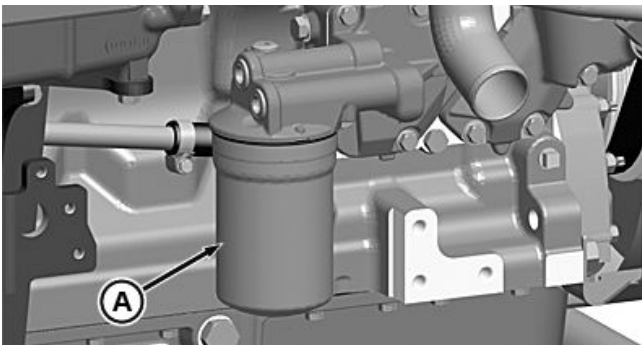

*Remove oil filter*

A- Oil filter

6. Watch coolant temperature gauge (A) closely. If coolant temperature rises above maximum coolant temperature (see GENERAL ENGINE SPECIFICATIONS in Specifications Section), reduce load on engine. Check sea (raw) water strainer for plugging on heat exchanger engines. Unless temperature drops quickly, stop the engine and determine the cause before resuming operation.

7. Check poly-vee belt for proper alignment and seating in pulley grooves. Two zinc plugs (A) are installed in the sea water cooling system to help neutralize the corrosive action of salt water on internal cavities of marine engine components. The reaction of the zinc, when exposed to the salt water, causes the plugs to deteriorate instead of critical engine components.

8. After the first 50—100 hours or 2—4 weeks of operation, remove zinc plug from each heat exchanger end cap (B) and inspect for corrosion to get an idea of rate of deterioration in sea water. If rate of corrosion is slight at 50—100 hours or 2—4 weeks initial inspection, zinc plugs should be inspected at 250 hour intervals thereafter. (See INSPECT AND REPLACE ZINC PLUGS in Lubrication & Maintenance/250 Hour Section)

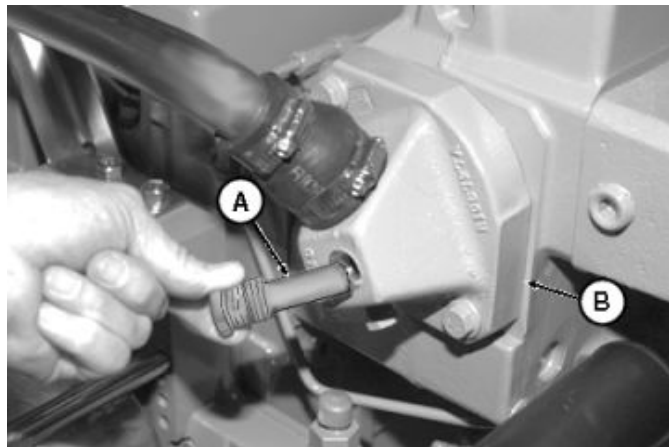

A- Zinc plugs

B- End cap

---

## Engine Operation

---

### GENERATOR SET POWER UNITS

To assure that your engine will deliver efficient generator operation when needed, start engine and run at rated speed (with 50%—70% load) for 30 minutes every 2 weeks. DO NOT allow engine to run extended period of time with no load.

### AUXILIARY GEAR DRIVE LIMITATIONS

**IMPORTANT:** When attaching a sea water pump or other accessory to be driven by the auxiliary gear drive (A) (engine timing gear train at front of engine), power requirements of the accessory must be limited to values listed below:

- 30 kW (40 hp) Continuous Operation
- 37 kW (50 hp) Intermittent Operation

A—Auxiliary Gear Drive

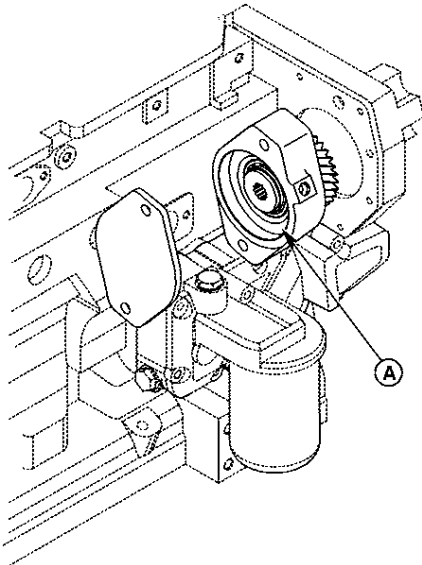

---

## Engine Operation

---

### STARTING THE ENGINE

#### CAUTION

Before starting engine in a confined engine room, install proper outlet exhaust ventilation equipment. Always use safety approved fuel storage and piping.

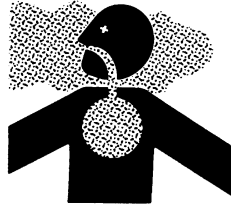

NOTE: Key switch (A) on main (standard) instrument panel must be in “ON” position to start engine using fly bridge (optional) instrument panel.

6. Press start button (B) to crank the engine. When the engine starts, release the button.
7. After the engine starts, observe the oil pressure gauge (C) until it reads at least the slow idle pressure specified for your engine in the Specifications Section.
8. Warm up the engine at or below 1200 rpm with no load for 1-2 minutes. See following guidelines.
9. Check all gauges for normal engine operation. If operation is not normal, stop the engine and determine the cause.
10. Check sea water outlet for water flow. Check exhaust pipe for water flow on engines with wet exhaust systems.

If sea water does not flow within one minute after engine starts, stop engine and check sea cock, sea water strainer, and sea water pump for restrictions.

### COLD WEATHER OPERATION

Additional information on cold weather operation is available from your authorized servicing dealer.

Some engines are equipped with an air intake heater which will make starting the engine easier in cold weather.

If equipped, follow steps 1–4 as listed under STARTING THE ENGINE, earlier in this section. Switch on the air intake heater for 30 seconds and then proceed to operate the starter. Follow remaining steps 5–11.

Synthetic oils improve flow at low temperatures, especially in arctic conditions.

#### CAUTION

Starting fluid is highly flammable.

DO NOT use starting fluid on engines equipped with air intake heaters.

DO NOT use starting fluid near fire, sparks, or flames. DO NOT incinerate or puncture starting fluid container.



---

## Engine Operation

---

### **KEEP ELECTRONIC CONTROL UNIT CONNECTORS CLEAN**

**IMPORTANT:** Do not open control unit and do not clean with a high-pressure spray. Moisture, dirt, and other contaminants may cause permanent damage.

1. Keep terminals clean and free of foreign debris. Moisture, dirt, and other contaminants may cause the terminals to erode over time and not make a good electrical connection.
2. If a connector is not in use, put on the proper dust cap or an appropriate seal to protect it from foreign debris and moisture.
3. Control units are not repairable.
4. Since control units are the components LEAST likely to fail, isolate failure before replacing by completing a diagnostic procedure. (See your Northern Lights dealer.)
5. The wiring harness terminals and connectors for electronic control units are repairable.

---

## Lubrication

---

### USE CORRECT FUELS, LUBRICANTS AND COOLANT

**IMPORTANT:** Use only fuels, lubricants and coolants that meet specifications outlined in this manual.

Consult your Northern Lights servicing dealer for recommended fuels, lubricants, and coolant. Also available are necessary additives for use when operating engines in tropical arctic, or any other adverse conditions.

### DIESEL FUEL

Consult your local fuel distributor for properties of the diesel fuel available in your area.

In general, diesel fuels are blended to satisfy the low temperature requirements of the geographical area in which they are marketed.

Diesel fuels specified to EN 590 or ASTM D975 are recommended. Renewable diesel fuel produced by hydrotreating animal fats and vegetable oils is basically identical to petroleum diesel fuel. Renewable diesel that meets EN 590 or ASTM D975 is acceptable for use at all percentage mixture levels.

### REQUIRED FUEL PROPERTIES

In all cases, the fuel shall meet the following properties:

**Cetane number of 43 minimum.** Cetane number greater than 47 is preferred, especially for temperatures below  $-20^{\circ}\text{C}$  ( $-4^{\circ}\text{F}$ ) or elevations above 1500 m (5000 ft.).

**Cold Filter Plugging Point (CFPP)** should be at least  $5^{\circ}\text{C}$  ( $9^{\circ}\text{F}$ ) below the expected lowest temperature or Cloud Point below the expected lowest ambient temperature.

**Fuel lubricity** should pass a maximum scar diameter of 0.45 mm as measured by ASTM D6079 or ISO 12156-1.

**Diesel fuel quality and sulfur content** must comply with all existing emissions regulations for the area in which the engine operates. **DO NOT** use diesel fuel with sulfur content greater than 10 000 mg/kg (10 000 ppm).

### Sulfur content for Interim Tier 4 and Stage III B engines

- Use **ONLY** ultra low sulfur diesel (ULSD) fuel with a maximum of 15 mg/kg (15 ppm) sulfur content.

### Sulfur Content for Tier 3 and Stage III A Engines

- Use of diesel fuel with sulfur content less than 1000 mg/kg (1000 ppm) is **RECOMMENDED**
- Use of diesel fuel with sulfur content 1000–5000 mg/kg (1000–5000 ppm) **REDUCES** oil and filter change intervals.
- **BEFORE** using diesel fuel with sulfur content greater than 5000 mg/kg (5000 ppm), contact your Northern Lights dealer

### Sulfur Content for Tier 2 and Stage II Engines

- Use of diesel fuel with sulfur content less than 500 mg/kg (500 ppm) is **RECOMMENDED**.
- Use of diesel fuel with sulfur content 500–5000 mg/kg (500–5000 ppm) **REDUCES** the oil and filter change interval
- **BEFORE** using diesel fuel with sulfur content greater than 5000 mg/kg (5000 ppm), contact your Northern Lights dealer

### Sulfur Content for Other Engines

- Use of diesel fuel with sulfur content less than 5000 mg/kg (5000 ppm) is recommended.
- Use of diesel fuel with sulfur content greater than 5000 mg/kg (5000 ppm) **REDUCES** the oil and filter change intervals.

**IMPORTANT:** Do not mix used diesel engine oil or any other type of lubricating oil with diesel fuel.

**IMPORTANT:** Improper fuel additive usage may cause damage on fuel injection equipment of diesel engines.

---

## Lubrication

---

### SUPPLEMENTAL DIESEL FUEL ADDITIVES

Diesel fuel can be the source of performance or other operational problems for many reasons. Some causes include poor lubricity, contaminants, low cetane number, and a variety of properties that cause fuel system deposits. These and others are referenced in other sections of this Operator's Manual.

To optimize engine performance and reliability, closely follow recommendations on fuel quality, storage, and handling, which are found elsewhere in this Operator's Manual.

To further aid in maintaining performance and reliability of the engine's fuel system, Northern Lights has developed a family of fuel additive products for most global markets. The primary products include Fuel-Protect Diesel Fuel Conditioner (full feature conditioner in winter and summer formulas) and Fuel-Protect Keep Clean (fuel injector deposit removal and prevention). Availability of these and other products varies by market. See your local dealer for availability and additional information about fuel additives that might be right for your needs.

### LUBRICITY OF DIESEL FUEL

Most diesel fuels manufactured in the United States, Canada, and the European Union have adequate lubricity to ensure proper operation and durability of fuel injection system components. However, diesel fuels manufactured in some areas of the world may lack the necessary lubricity.

**IMPORTANT:** Make sure the diesel fuel used in your machine demonstrates good lubricity characteristics.

Fuel lubricity should pass a maximum scar diameter of 0.45 mm as measured by ASTM D6079 or ISO 12156-1.

If fuel of low or unknown lubricity is used, add Northern Lights Fuel-Protect Diesel Fuel Conditioner (or equivalent) at the specified concentration.

Fuel lubricity can improve significantly with **biodiesel blends** up to B20 (20% biodiesel). Further increase in lubricity is limited for biodiesel blends greater than B20.

### HANDLING AND STORING DIESEL FUEL

#### **WARNING**

Reduce the risk of fire. Handle fuel carefully. **DO NOT** fill the fuel tank when engine is running. **DO NOT** smoke while you fill the fuel tank or service the fuel system.



Fill the fuel tank at the end of each day's operation to prevent water condensation and freezing during cold weather.

Keep all storage tanks as full as practicable to minimize condensation.

Ensure that all fuel tank caps and covers are installed properly to prevent moisture from entering. Monitor water content of the fuel regularly.

When using biodiesel fuel, the fuel filter may require more frequent replacement due to premature plugging.

Check engine oil level daily prior to starting engine. A rising oil level may indicate fuel dilution of the engine oil.

**IMPORTANT:** The fuel tank is vented through the filler cap. If a new filler cap is required, always replace it with an original vented cap.

When fuel is stored for an extended period or if there is a slow turnover of fuel, add a fuel conditioner to stabilize the fuel and prevent water condensation. Contact your fuel supplier for recommendations.

---

## Lubrication

---

### **BIODIESEL FUEL**

Biodiesel fuel is comprised of mono-alkyl esters of long chain fatty acids derived from vegetable oils or animal fats. Biodiesel blends are biodiesel mixed with petroleum diesel fuel on a volume basis.

Before using fuel containing biodiesel, review the Biodiesel Use Requirements and Recommendations in this Operator's Manual.

Environmental laws and regulations can encourage or prohibit the use of biofuels. Operators should consult with appropriate governmental authorities prior to using biofuels.

#### **All Northern Lights Engines with Exhaust Filter (Released 2011 and After)**

While 5% blends (B5) are preferred, biodiesel concentrations up to a 20% blend (B20) in petroleum diesel fuel can be used. Biodiesel blends up to B20 can be used ONLY if the biodiesel (100% biodiesel or B100) meets ASTM D6751, EN 14214, or equivalent specification. Expect a 2% reduction in power and a 3% reduction in fuel economy when using B20.

Biodiesel concentrations above B20 can harm the engine's emission control systems and should not be used. Risks include, but are not limited to, more frequent stationary regeneration, soot accumulation, and increased intervals for ash removal.

Northern Lights approved fuel conditioners, which contain detergent and dispersant additives, are required when using B20, and are recommended when using lower biodiesel blends.

#### **All Northern Lights Engines Excluding Exhaust Filter (Primarily Released Prior to 2012)**

While 5% blends (B5) are preferred, biodiesel concentrations up to a 20% blend (B20) in petroleum diesel fuel can be used. Biodiesel blends up to B20 can be used ONLY if the biodiesel (100% biodiesel or B100) meets ASTM D6751, EN 14214, or equivalent specification. Expect a 2% reduction in power and a 3% reduction in fuel economy when using B20.

These Northern Lights engines can operate on biodiesel blends above B20 (up to 100% biodiesel). Operate at levels above B20 ONLY if the biodiesel is permitted by law and meets the EN 14214 specification (primarily available in Europe). Engines operating on biodiesel blends above B20 might not fully comply with or be permitted by all applicable emissions regulations. Expect up to a 12% reduction in power and an 18% reduction in fuel economy when using 100% biodiesel.

Northern Lights approved fuel conditioners, which contain detergent and dispersant additives, are required when using B20, and are recommended when using lower biodiesel blends.

#### **Biodiesel Use Requirements and Recommendations**

The petroleum diesel portion of all biodiesel blends must meet the requirements of ASTM D975 (US) or EN 590 (EU) commercial standards.

Biodiesel users in the U.S. are strongly encouraged to purchase biodiesel blends from a BQ-9000 Certified Marketer and sourced from a BQ-9000 Accredited Producer (as certified by the National Biodiesel Board). Certified Marketers and Accredited Producers can be found at the following website: <http://www.bq9000.org>.

Biodiesel contains residual ash. Ash levels exceeding the maximums allowed in either ASTM D6751 or EN14214 can result in more rapid ash loading and require more frequent cleaning of the Exhaust Filter (if present).

The fuel filter can require more frequent replacement, when using biodiesel fuel, particularly if switching from diesel. Check engine oil level daily prior to starting engine. A rising oil level can indicate fuel dilution of the engine oil. Biodiesel blends up to B20 must be used within 90 days of the date of biodiesel manufacture. If used, biodiesel blends above B20 must be used within 45 days from the date of biodiesel manufacture.

When using biodiesel blends up to B20, the following must be considered:

- Cold weather flow degradation
- Stability and storage issues (moisture absorption, microbial growth)
- Possible filter restriction and plugging (usually a problem when first switching to biodiesel on used engines.)
- Possible fuel leakage through seals and hoses (primarily an issue with older engines)
- Possible reduction of service life of engine components.

Request a certificate of analysis from your fuel distributor to ensure that the fuel is compliant with the specifications provided in this Operator's Manual.

---

## Lubrication

---

Consult your Northern Lights dealer for approved fuel conditioners to improve storage and performance with biodiesel fuels.

The following must also be considered if using biodiesel blends above B20:

- Possible coking or blocked injector nozzles, resulting in power loss and engine misfire if Northern Lights approved fuel conditioners are not used
- Possible crankcase oil dilution (requiring more frequent oil changes)
- Possible lacquering or seizure of internal components
- Possible formation of sludge and sediments
- Possible thermal oxidation of fuel at elevated temperatures
- Possible compatibility issues with other materials (including copper, lead, zinc, tin, brass, and bronze) used in fuel handling equipment
- Possible reduction in water separator efficiency
- Possible damage to paint if exposed to biodiesel
- Possible corrosion of fuel injection equipment
- Possible elastomeric seal and gasket material degradation (primarily an issue with older engines)
- Possible high acid levels within fuel system
- Because biodiesel blends above B20 contain more ash, using blends above B20 can result in more rapid ash loading and require more frequent cleaning of the Exhaust Filter (if present)

**IMPORTANT:** Raw pressed vegetable oils are NOT acceptable for use as fuel in any concentration in Northern Lights engines. Their use could cause engine failure.

### Testing Diesel Fuel

A fuel analysis program can help to monitor the quality of diesel fuel. The fuel analysis can provide critical data such as cetane number, fuel type, sulfur content, water content, appearance, suitability for cold weather operations, bacteria, cloud point, acid number, particulate contamination, and whether the fuel meets specification.

Contact your Northern Lights dealer for more information on diesel fuel analysis.

### Fuel Filters

The importance of fuel filtration cannot be overemphasized with modern fuel systems. The combination of increasingly restrictive emission regulations and more efficient engines requires fuel system to operate at much higher pressures. Higher pressures can only be achieved using fuel injection components with very close tolerances. These close manufacturing tolerances have significantly reduced capacities for debris and water.

Northern Lights brand fuel filters have been designed and produced specifically for Northern Lights engines. A complete list of fuel filters by part number is on the Northern Lights Quick Reference Filter Chart (L653), available from your Northern Lights Authorized Dealer or through NLI's web site: [www.northern-lights.com](http://www.northern-lights.com).

To protect the engine from debris and water, always change engine fuel filters as specified in this manual.

### DIESEL ENGINE OIL

Use oil viscosity based on the expected air temperature range during the period between oil changes. Oil viscosity must meet one or more of the following:

- Torq-Gard™
- API Service Category CJ-4
- API Service Category CI-4 PLUS
- API Service Category CI-4
- ACEA Oil Sequence E9
- ACEA Oil Sequence E7
- ACEA Oil Sequence E6
- ACEA Oil Sequence E5
- ACEA Oil Sequence E4

Multi-viscosity diesel engine oils are preferred.

Diesel fuel quality and fuel sulfur content must comply with all existing emissions regulations for the area in which the engine operates.

**DO NOT use diesel fuel with sulfur content greater than 10,000 (mg/kg) (10,000 ppm)**

---

## Lubrication

---

### Mixing of Lubricants

In general, avoid mixing different brands or types of oil. Oil manufacturers blend additives in their oils to meet certain specifications and performance requirements. Mixing different oils can interfere with the proper functioning of these additives and degrade lubricant performance.

### Alternative and Synthetic Lubricants

Conditions in certain geographical areas may require lubricant recommendations different from those printed in this manual. Some Northern Lights brand coolants and lubricants may not be available in your location. Consult your Northern Lights dealer to obtain information and recommendations. Synthetic lubricants may be used if they meet the performance requirements as shown in this manual.

The temperature limits and service intervals shown in this manual apply to both conventional and synthetic lubricants.

Re-refined base stock products may be used if the finished lubricant meets the performance requirements.

### DIESEL ENGINE OIL AND FILTER SERVICE INTERVALS

The oil and filter service intervals in the maintenance schedule (page 27) should be used as a reference. Actual service intervals also depend on operation and maintenance practices. It is suggested to use oil analysis to determine the actual useful life of the oil and to aid in selection of the proper oil and filter service interval.

Oil and filter service intervals are based on a combination of oil pan capacity, type of engine oil and filter used, and sulfur content of the diesel fuel.

NOTE: The service interval of "Other Oils" may be extended only if oil analysis is performed to determine the actual service life, to a maximum not to exceed that of Plus-50.

Diesel fuel sulfur level will affect engine oil and filter service intervals. Higher fuel sulfur levels reduce oil and filter service intervals as shown in the table.

- Use of diesel fuel with sulfur content less than 0.05% (500 mg/kg) is strongly recommended.

- Use of diesel fuel with sulfur content 0.05% (500 mg/kg) to 0.50% (5000 mg/kg) may result in REDUCED oil and filter change intervals as shown in the table.
- BEFORE using diesel fuel with sulfur content greater than 0.50% (5000 mg/kg), contact your Northern Lights dealer.

**IMPORTANT:** When using biodiesel blends greater than B20, reduce the oil and filter service interval by 50% or monitor engine oil based on test results from Oilscan.

Oil types in the table include:

- Northern Lights Plus-50 II and John Deere Plus-oils.
- Other oils" include Torq-Gard Supremen

API CJ-4, API CK-4, API CI-4, ACEA E9, ACEA E7, ACEA E6 or ACEA E5

### LUBRICANT STORAGE

Your equipment can operate at top efficiency only when clean lubricants are used. Use clean containers to handle all lubricants.

Store lubricants and containers in an area protected from dust, moisture, and other contamination. Store containers on their side to avoid water and dirt accumulation.

Make certain that all containers are properly marked to identify their contents. Properly dispose of all old containers and any residual lubricant they may contain.

### OIL FILTERS

Filtration of oils is critically important for proper operation and lubrication. Northern Lights brand oil filters have been designed and produced specifically for Northern Lights applications.

Northern Lights filters adhere to engineering specifications for quality of the filter media, filter efficiency rating, strength of the bond between the filter media and the element end cap, fatigue life of the canister (if applicable), and pressure capability of the filter seal. Non-Northern Lights branded oil filters might not meet these key specifications.

Always change oil filters regularly as specified in this manual.



## Coolant

### ENGINE COOLANTS (for engines with wet sleeve cylinder liners)

#### Preferred Coolants

The following pre-mix engine coolants are preferred:

- Northern Lights COOL-GARD™II
- Northern Lights COOL-GARD II PG

COOL-GARD II pre-mix coolant is available in several concentrations with different freeze protection limits as shown in the following table.

Cool-Gard II pre-mix	Freeze protection limit
Cool-Gard II 20/80	-9° C (16° F)
Cool-Gard II 30/70	-16° C (3° F)
Cool-Gard II 50/50	-37° C (-34° F)
Cool-Gard II 55/45	-45° C (-49° F)
Cool-Gard II PG 60/40	-49° C (-56° F)
Cool-Gard II 60/40	-52° C (-62° F)

Not all COOL-GARD II pre-mix products are available in all countries.

Use COOL-GARD II PG when a non-toxic coolant formulation is required.

#### Additional Recommended Coolants

The following engine coolant is also recommended:

- Northern Lights COOL-GARD II Concentrate in a 40-60% mixture of concentrate with quality water.

**IMPORTANT:** When mixing coolant concentrate with water, do not use less than 40% or greater than 60% concentration of coolant. Less than 40% gives inadequate additives for corrosion protection. Greater than 60% can result in coolant gelation and cooling system problems.

#### Other Coolants

Other ethylene glycol or propylene glycol base coolants may be used if they meet the following specification:

- Pre-mix coolant meeting ASTM D6210 requirements
- Coolant concentrate meeting ASTM D6210 requirements in a 40-60% mixture of concentrate with quality water

#### WATER QUALITY FOR MIXING WITH COOLANT CONCENTRATE

Engine coolants are a combination of three chemical components: ethylene glycol (EG) or propylene glycol (PG) antifreeze, inhibiting coolant additives, and quality water.

Water quality is important to the performance of the cooling system. Distilled, deionized, or demineralized water is recommended for mixing with ethylene glycol and propylene glycol base engine coolant concentrate.

All water used in the cooling system should meet the following minimum specifications for quality:

Chlorides	<40 mg/L
Sulfates	<100 mg/L
Total solids	<340 mg/L
Total dissolved l hardness	<170 mg/L
pH	5.5 - 9.0

**IMPORTANT:** Do not use bottled drinking water because it often contains higher concentrations of total dissolved solids.

**IMPORTANT:** Do not use water from reverse osmosis water makers.

---

## Coolant

---

### FREEZE PROTECTION

The relative concentrations of glycol and water in the engine coolant determine its freeze protection limit.

Ethylene Glycol	Freeze protection limit
40%	-24° C (-12° F)
50%	-37° C (-34° F)
60%	-52° C (-62° F)
Propylene Glycol	Freeze protection limit
40%	-21° C (-6° F)
50%	-33° C (-27° F)
60%	-49° C (-56° F)

DO NOT use a coolant-water mixture greater than 60% ethylene glycol or 60% propylene glycol.

### OPERATING IN WARM TEMPERATURE CLIMATES

Always use a recommended engine coolant, even when operating in geographical areas where freeze protection is not required.

**IMPORTANT:** Water may be used as coolant in emergency situations only.

Foaming, hot surface aluminum and iron corrosion, scaling, and cavitation occur when water is used as the coolant, even when coolant conditioners are added.

Drain cooling system and refill with recommended engine coolant as soon as possible.



## Service and Maintenance Chart

The Servicing Schedule Chart below shows the service schedule required for proper maintenance of your marine generator set. More detailed coverage of each Service Point (SP) is listed on the page noted in the 'page' column.

SERVICE POINT	PAGE	OPERATION	DAILY	250 Hours	500 Hours	2000 Hours	As Required
SP1	28	Check engine oil level	•				
SP2	29	Check coolant level	•				
SP3	29	Check seawater strainer	•				
SP4	29	Check air cleaner and restriction indicator 1)	•				
SP5	30	Drain water from fuel filter	•				
SP6	30	Visual walk around inspection	•				
SP7	31-32	Change engine oil and replace oil filter 2)		•			
SP9	33	Service battery		•			
SP10	34	Inspect/replace zinc plugs		•			
SP11	34	Check belt tension and wear (manual tensioner)		•			
SP12	35	Replace crankcase vent filter (if equipped)		•			
SP13	35	Clean crankcase ventilation assembly		•			
SP14	36	Check air intake hoses, connections and system			•		
SP15	37	Replace fuel filter elements			•		
SP16	38	Check automatic belt tensioner and belt wear			•		
SP17	39	Check tensioner spring			•		
SP18	40	Check cooling system			•		
SP19	40	Coolant solution analysis - add SCA's as required			•		
SP20	41-43	Inspect and clean heat exchanger core and aftercooler core (if equipped)			•		
SP21	44	Pressure test cooling system			•		
SP22	45	Flush and refill engine cooling system			•		
SP23	45	Check engine electrical ground			•		
SP24	46-47	Check and adjust engine valve clearance				•	
SP25	48	Check crankshaft vibration damper (M150C13 only)				•	
SP26	49-50	Test thermostats				•	
SP27	51-55	Inspect/repair seawater pump				•	
SP28	56	Install impeller				•	
SP29	57	Add coolant					•
SP30	57-60	Service/Replace air cleaner element					•
SP31	61	Replace alternator belt					•
SP32	62	Bleed fuel system					•

1) Replace primary air cleaner element when restriction indicator shows a vacuum of 625 mm (52 in.) H2O, or when reset button has popped up.

2) Change the oil for the first time before 100 hours maximum of (break-in) operation, then every 250 hours thereafter.

**DAILY:**

- SP1 Check oil level in engine
- SP6 Check primary fuel filter
- SP14 Check cooling water level
- SP21 Check crankcase vent system filter svc. indicator button

**AFTER FIRST 50 HOURS:**

- SP2 Change engine oil
- SP3 Change lube oil filter

**EVERY 50 HOURS:**

- SP19 Check electrolyte in batteries

**AFTER FIRST 100 HOURS/ EVERY TWO WEEKS <sup>5</sup>:**

- SP2 Change engine oil after first 100 hrs., then check every 2 wks.
- SP3 Change oil filter after first 100 hrs., then check every 2 wks.
- SP9 Check crankshaft vibration damper<sup>7</sup>
- SP14 Check coolant level

**EVERY 250 HOURS :**

- SP2 Change engine oil
- SP3 Change lube oil filter
- SP4 Check air cleaner
- SP17 Check zincs
- SP21 Check crankcase vent system, change element at 250 hrs.

**EVERY 500 HOURS / YEARLY:**

- SP4 Replace air cleaner
- SP6 Change primary filter element (Racor)
- SP8 Change secondary fuel filter
- SP10 Check injectors
- SP13 Check turbocharger boost pressure
- SP15 Check cooling system
- SP18 Change impeller in raw water pump
- SP19 Check the state of the charge of the batteries

**EVERY 2000 HOURS:**

- SP5 Check & adjust valve clearance
- SP9 Check crankshaft vibration damper
- SP11 Check fuel injection pump
- SP15 Flush cooling system

---

## Service and Maintenance - Daily

---

### DAILY PRE-START CHECKS

Do the following **BEFORE STARTING THE GENERATOR SET** for the first time each day:

**IMPORTANT:** DO NOT add makeup oil until the oil level is **BELOW** the add mark.

Depending on application, oil dipstick (A) and oil filler cap (B) may be located on either the left or the right side of engine. In addition, oil may be added at rocker arm filler cap (C).

#### SP1. Check engine oil level

Check engine oil level on dipstick (A). Add as required, using seasonal viscosity grade oil. (See **DIESEL ENGINE OIL** in Fuels, Lubricants, and Coolant Section for oil specifications.)

**IMPORTANT:** DO NOT fill above the top mark on the dipstick. Oil levels anywhere within crosshatch (D) are considered in the acceptable operating range.

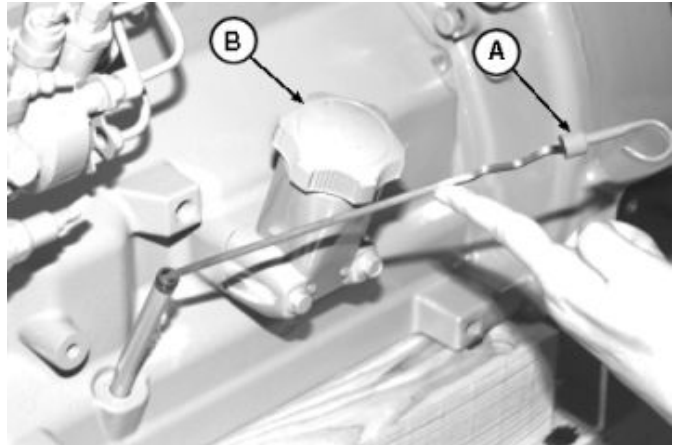

*Left side dipstick - M50C13, M65C13, M99C13*

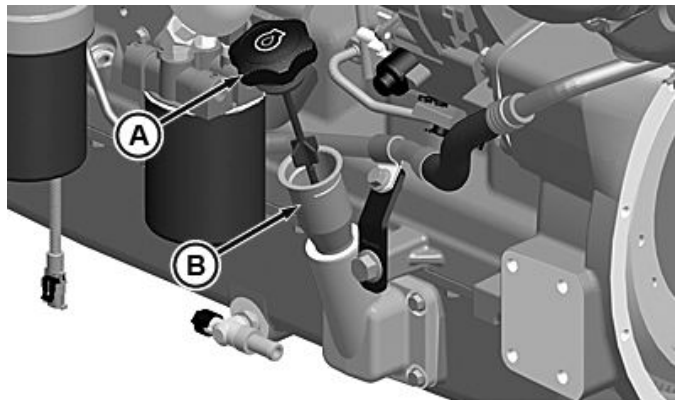

*Left side oil fill and dipstick location*

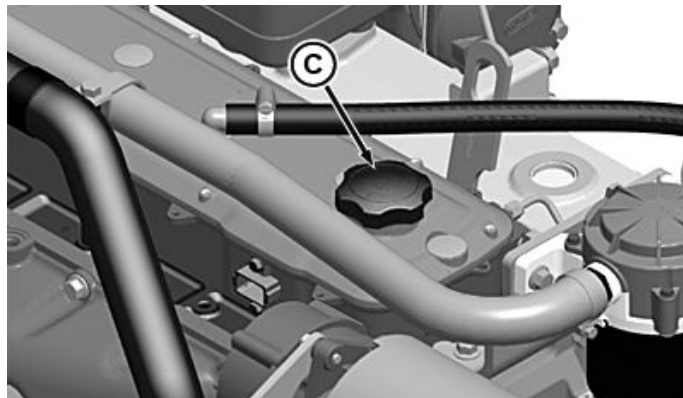

*Rocker arm cover filler cap*

A- Dipstick

B- Left side oil filler cap

C- Rocker arm filler cap

## Service and Maintenance - Daily

### SP2. Check coolant level

#### **CAUTION**

*The cooling water in the engine reaches extremely high temperatures. You must use extreme caution when working on hot engines to avoid burns. Allow the engine to cool before working on the cooling system. Open the filler cap carefully, using protective clothing when the engine is warm.*



Remove the pressure cap from the expansion tank and check water level. In order to give the coolant an opportunity to expand, the level should be about 1 3/4 in. (4-5 cm) below the filler cap sealing surface when the engine is cold. When filling with coolant, the venting cock on top of the turbocharger (for engines fitted with turbocharger) should be opened to ensure that no air pockets form in the cooling system.

### SP3. Check seawater strainer

**IMPORTANT:** A restricted or clogged sea water strainer will result in hotter than normal (or overheated) engine coolant and marine gear oil temperatures.

The sea water strainer should be checked daily and cleaned as required, depending upon the operating environment.

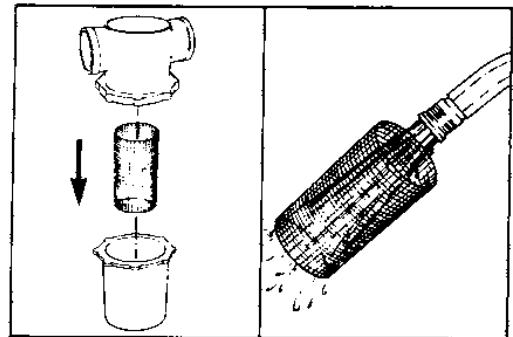

Seawater strainer

### SP4. Check air cleaner and restriction indicator

If equipped with air intake restriction indicator gauge (A), check gauge to determine if air cleaner needs to be serviced. The reset button will pop up when air cleaner needs to be serviced.

**IMPORTANT:** Maximum air intake restriction is 625 mm (25 in. H<sub>2</sub>O). A clogged air cleaner element will cause excessive intake restriction and a reduced air supply to the engine.

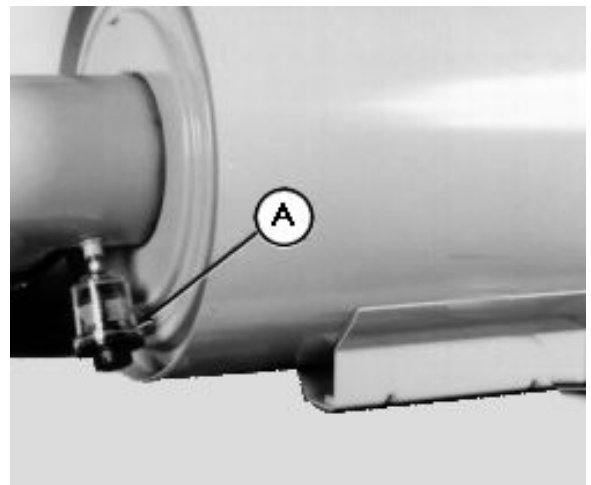

Air cleaner

A- Air intake restriction gauge

---

## Service and Maintenance - Daily

---

### SP5. Drain Water From Fuel Filter

**IMPORTANT:** When using BIODIESEL blends, monitor water quantity more closely in the fuel filter element. Water in the filter separator may need to be drained more frequently.

If instrument panel provides a water in fuel warning, drain water or debris from filter using the following steps.

1. Loosen thumb screw (A) and drain water and debris into a suitable container. Tighten thumb screw.
2. Dispose of water and debris in an environmentally safe manner.



### SP6. Visually inspect the entire generator set

Make a thorough inspection of the engine room. Look for oil or coolant leaks, worn drive belts, loose connections and trash build-up. Remove trash buildup and have repairs made as needed if leaks are found.

**NOTE:** Wipe all fittings, caps, and plugs before performing any maintenance to reduce the chance of system contamination.

Inspect:

- Engine shields and guards for trash build-up.
- Air intake system hoses and connections for cracks and loose clamps.
- Alternator drive belt for cracks, breaks or other damage.
- Water pump for coolant leaks.
- Coolant system for leaks.

**NOTE:** It is normal for a small amount of leakage to occur as the engine cools down and parts contract. Excessive coolant leakage may indicate the need to replace the water pump seal. Contact your servicing dealer for repairs.

## Service and Maintenance - 250 Hours

### 250 HOUR MAINTENANCE

The following service steps are to be performed every 250 hours at minimum to ensure proper performance.

#### SP 7. Change engine oil and replace oil filter

NOTE: Change engine oil and filter for the first time before 100 hours maximum of operation, then every 250 hours thereafter.

**IMPORTANT:** If using BIODIESEL blends greater than B20, shorten oil change interval to half the recommended service interval or monitor engine oil using OILSCAN to ensure that fuel dilution does not exceed 5%.

1. Run engine approximately 5 minutes to warm up oil. Shut engine off before changing oil.
2. Remove oil pan drain plug (see arrow, below)

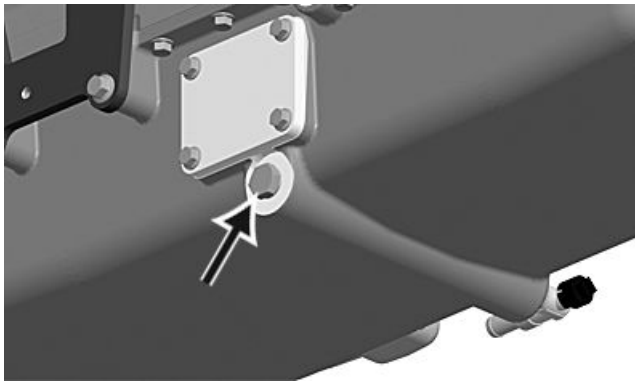

3. Drain crankcase oil from engine while warm
4. Turn filter element (A, below) using a suitable filter wrench to remove. Discard oil filter element.

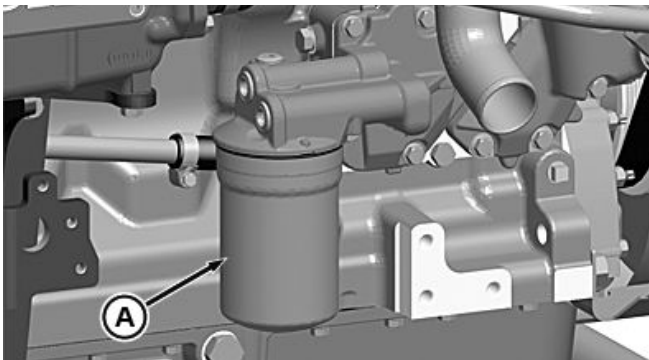

NOTE: Depending on engine application, oil filter may be located on either side of the engine in a high- or low-mount location.

**IMPORTANT:** Filtration of oils is critical to proper lubrication. Always change filter regularly. Use filter meeting Northern Lights performance specifications.

5. Apply clean engine oil to the new filter at the inner (B) and outer (C) seals and to filter threads.

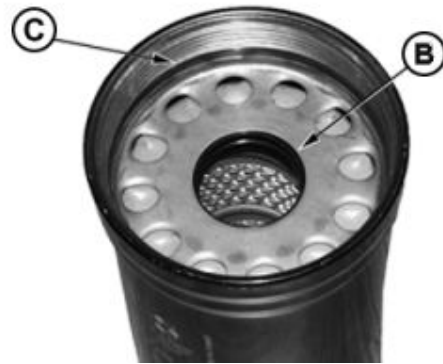

6. Wipe both sealing surfaces of the header with a clean rag. Ensure that the notches in dust seal are properly installed in the slots of the housing. Replace if damaged.

**IMPORTANT:** When installing filter element, **HAND TIGHTEN** only. A filter wrench may be used for **REMOVAL ONLY**.

7. Install and tighten oil filter by hand until firmly against dust seal. **DO NOT** apply an extra 3/4 to 1-1/4 turn after gasket contact as done with standard filters.
8. Tighten drain plug to the following specifications:

Oil Pan Drain Plug with Copper Washer  
Torque ..... 70 N-m (52 lb-ft)

Oil Pan Drain Plug with O-Ring  
Torque ..... 50 N-m (37 lb-ft)

continued on next page

---

## Service and Maintenance - 250 Hour

---

9. Fill engine crankcase with correct engine oil through rocker arm cover opening (A, below). (See DIESEL ENGINE OIL in Fuels, Lubricants, and Coolant Section for determining correct engine oil.)

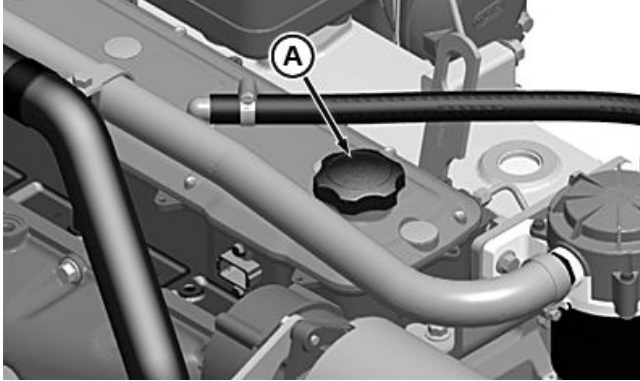

To determine the correct oil fill quantity for your engine, see ENGINE CRANKCASE OIL FILL QUANTITIES in the Specifications Section of this manual.

NOTE: Crankcase oil capacity may vary slightly. ALWAYS fill crankcase within crosshatch marks on dipstick. DO NOT overfill.

10. Start engine and run to check for possible leaks.

11. Stop engine and check oil level after 10 minutes. Oil level reading should be within crosshatch on dipstick.



## Service and Maintenance - 250 Hour

### SP9. Service Battery

#### **WARNING**

Battery gas is highly flammable. Battery explosions can cause severe injury or death. To help prevent battery explosions, keep sparks, lighted matches and open flame away from the top of battery. When checking battery electrolyte level, use a flashlight.



Never check battery charge by contacting the posts with a metal object. Use a volt-meter or hydrometer.

Frozen batteries may explode if charged. Never charge a battery that has not been allowed to warm to at least 16°C (60°F).

Always remove grounded (-) battery clamp first and replace ground clamp last.

#### **CAUTION**

Battery posts, terminals and related accessories contain lead and lead compounds, chemicals known to the State of California to cause cancer and reproductive harm.

#### **Wash hands after handling.**

1. On regular batteries, check electrolyte level. Fill each cell to bottom of filler neck with distilled water.

NOTE: Low-maintenance or maintenance-free batteries should require little additional service. However, electrolyte level can be checked by cutting the center section of decal on dash-line, and removing cell plugs. If necessary, add clean, soft water to bring level to bottom of filler neck.

2. Keep batteries clean by wiping them with a damp cloth. Keep all connections clean and tight. Remove any corrosion, and wash terminals with a solution of 1 part baking soda and 4 parts water. Tighten all connections securely.

NOTE: Coat battery terminals and connectors with a mixture of petroleum jelly and baking soda to retard corrosion.

3. Keep battery fully charged, especially during cold weather. If a battery charger is used, turn charger off before connecting charger to battery(ies). Attach POSITIVE (+) battery charger lead to POSITIVE (+) battery post. Then attach NEGATIVE (-) battery charger lead to a good ground.

#### **CAUTION**

CAUTION: Sulfuric acid in battery electrolyte is poisonous. It is strong enough to burn skin, eat holes in clothing, and cause blindness if splashed into eyes.

Avoid the hazard by:

1. Filling batteries in a well-ventilated area.
2. Wearing eye protection and rubber gloves.
3. Avoiding breathing fumes when electrolyte is added.
4. Avoiding spilling or dripping electrolyte.
5. Use proper jump start procedure.

If you spill acid on yourself:

1. Flush your skin with water.
2. Apply baking soda or lime to help neutralize the acid.
3. Flush your eyes with water for 10–15 minutes. Get medical attention immediately.

If acid is swallowed:

1. Drink large amounts of water or milk.
2. Then drink milk of magnesia, beaten eggs, or vegetable oil.
3. Get medical attention immediately.

In freezing weather, run engine at least 30 minutes to assure thorough mixing after adding water to battery. If necessary to replace battery(ies), replacements must meet or exceed the following recommended capacities at -18°C (0°F):

12 Volt Standard Duty Starter  
Cold Cranking Amps..... 640

12 Volt Heavy Duty Starter  
Cold Cranking Amps..... 800

24 Volt Standard Duty Starter  
Cold Cranking Amps..... 570

## Service and Maintenance - 250 Hour

### SP10. Inspect and Replace Zinc Plugs

Two zinc plugs (shown below - A) are installed in the sea water cooling system to help reduce the corrosive action of salt in the sea water. The reaction of the zinc to sea water causes the plugs to deteriorate, instead of the more critical cooling system parts. Therefore, the zinc plugs **MUST BE** inspected every 250 Hours.

NOTE: Zinc plugs are located in each heat exchanger end cap and are mounted on hex-head pipe plug.

1. Remove zinc rod from each end cap (B- shown below) and observe condition of each.
2. Tap the zinc rods lightly with a hammer. If rod flakes apart when tapped, install a new zinc plug.
3. Measure zinc plugs (A) to determine the amount of erosion on length (B) and outer diameter (C).

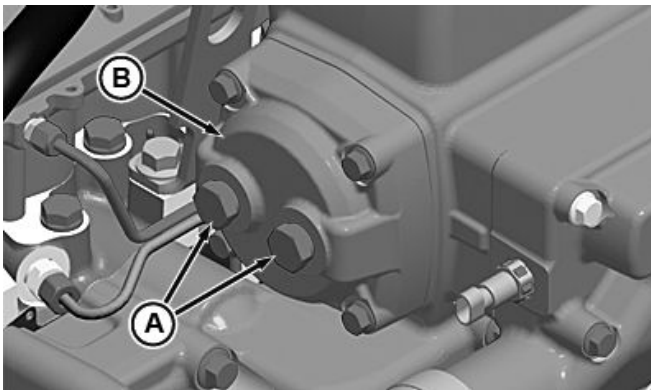

Location of zinc plugs (A) and end cap (B)- M50C13, M65C13, M99C13

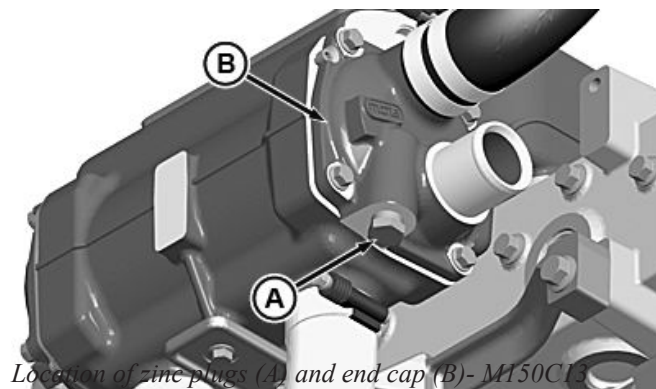

Location of zinc plugs (A) and end cap (B)- M150C13

If length is less than 15.9 mm (0.63 in.) or outer diameter is less than 4.8 mm (0.19 in.) on either plug, replace all zinc plugs.

NOTE: Zinc plug new part dimensions are 31.8 mm (1.25 in.) long and 9.5 mm (0.38 in.) outer diameter.

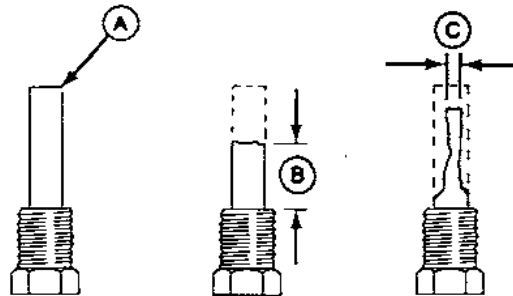

### SP11. Check belt tension and wear

1. Remove belt guard (A).
2. Swing tensioner arm (C) to remove all belt slack.
3. Remove and inspect belt for cracks, fraying, or stretched-out areas. Replace if necessary.

NOTE: While belt is removed, inspect pulleys and bearings. Rotate and feel for hard turning or any unusual sounds. If pulleys or bearings need replacement, see your Northern Lights dealer.

4. If tensioner has been removed, tighten tensioner mounting cap screw (B) to 70 N·m (52 lb-ft).
5. Install belt guard.

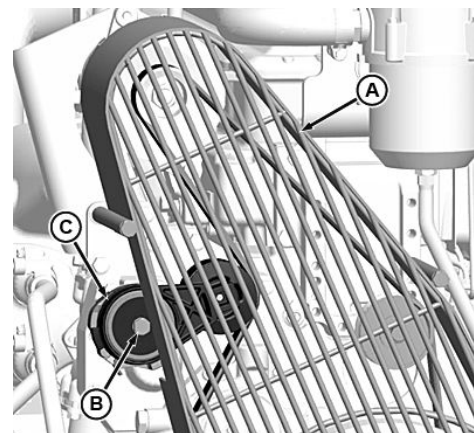



## Service and Maintenance - 250 Hour

### SP12. Replace Crankcase Vent Filter

1. Remove screws (A) and remove the crankcase vent lid.
2. Remove old filter and discard.
3. Install new filter into crankcase vent housing and snap into place.
4. Install lid and lock down screws.

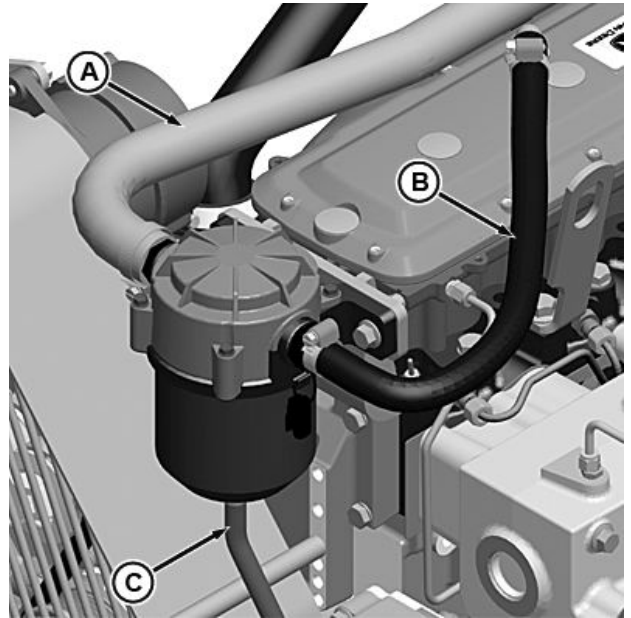
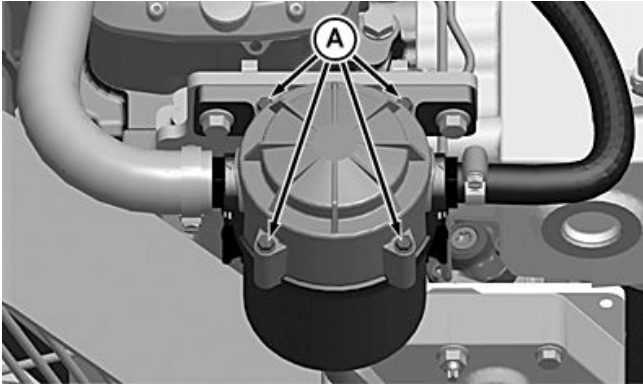

*Location of hoses on crankcase. A - compressor to filter housing. B - rocker arm cover to filter housing. C - oil drain*

### SP13. Checking Closed Crankcase Vent System

1. Inspect hoses (A, B and C, upper right) and oil drain line (D, below right) for kinks, blockage, or other damage.
2. Inspect crankcase fitting (E, below right) for damage and make sure it is not plugged.
3. Verify that the crankcase vent system bypass port (E, below right ) is not plugged.
4. Inspect turbocharger compressor coupling for cracks, blockage or other damage

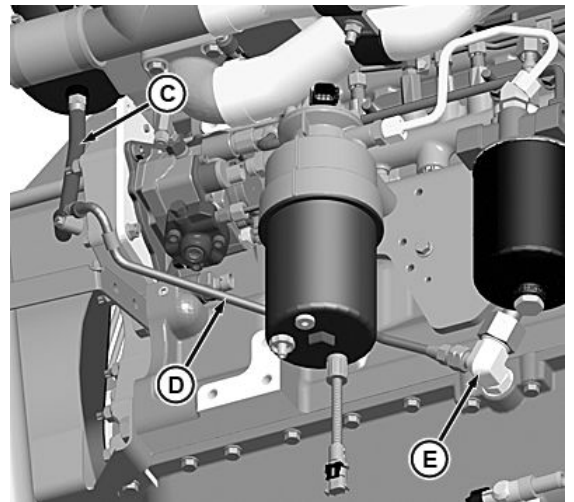

*Location of oil drain hose (C), oil drain line (D) and bypass port (E) - crankcase*

## Service and Maintenance - 500 Hour

### 500 HOUR MAINTENANCE

The following service steps are to be performed every 500 hours at minimum to ensure proper performance.

#### SP 14. Check air intake hoses, connections and system

Make a thorough visual inspection of all hoses, connectors and any other pieces that could exhibit wear. Look for signs of decay, corrosion or other ways that hoses and connection can be compromised. Replace any worn items prior to starting the generator set.

#### SP 15. Replace Fuel Filter

### CAUTION

Escaping fluid under pressure can penetrate the skin causing serious injury. Relieve pressure before disconnecting fuel or other lines.



**Tighten all connections before applying pressure.**

**Keep hands and body away from pinholes and nozzles which eject fluids under high pressure.**

**Use a piece of cardboard or paper to search for leaks. Do not use your hand.**

1. Close fuel shut-off valve at bottom of fuel tank
2. Clean entire area surrounding fuel filter assembly to keep debris from entering fuel system.
3. Loosen drain plug and air vent screw. Drain fuel into suitable container.

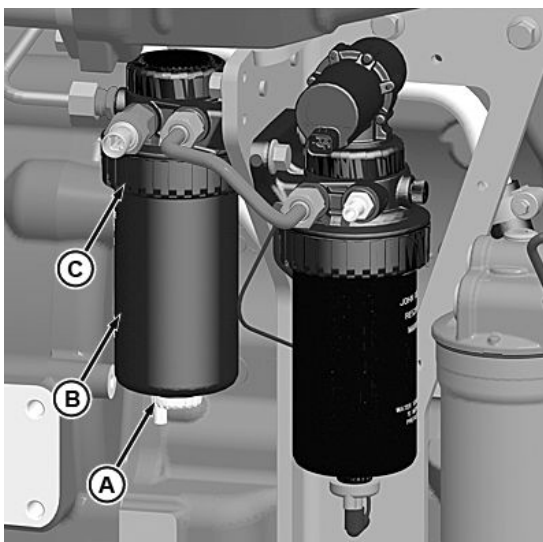

Location of drain (A), filter/filter housing (B) and filter base (C)- M50C13, M65C13, M99C13

4. Firmly grasp the filter or filter housing and rotate it clockwise 1/4 turn (when viewed from the top to remove from base.

5. Inspect filter mounting base for cleanliness. Clean as required.

NOTE: Raised locators on fuel filter canister must be indexed properly with slots in mounting base for correct installation.

6. Install new filter element onto mounting base. Be sure element is properly indexed and firmly seated on base. It may be necessary to rotate filter for correct alignment. If equipped with a water separator bowl, remove separator bowl from filter element. Drain and clean separator bowl. Dry with compressed air. Install bowl onto new filter element. Tighten securely.

7. Align keys on filter element with slots in filter base.

8. Install retaining ring onto mounting base making certain dust seal is in place on filter base. Hand tighten ring (about 1/3 turn) until it “snaps” into the detent. DO NOT overtighten retaining ring.

NOTE: The proper installation is indicated when a “click” is heard and a release of the retaining ring is felt. A plug is provided with the new element for plugging the used element.

9. Open fuel shut-off valve. Whenever the fuel system has been opened up for service (lines disconnected or filters removed), it will be necessary to bleed air from the system. (See BLEEDING THE FUEL SYSTEM on Page 63)

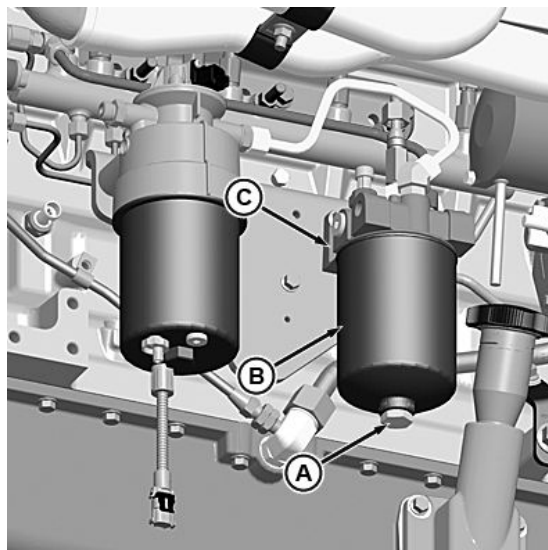

Location of drain (A), filter/filter housing (B) and filter base (C) - M150C13

## Service and Maintenance - 500 Hour

### SP15. Replace fuel filter/water separator

#### CAUTION

Escaping fluid under pressure can penetrate the skin causing serious injury. Relieve pressure before disconnecting fuel or other lines.



Tighten all connections before applying pressure.

Keep hands and body away from pinholes and nozzles which eject fluids under high pressure.

Use a piece of cardboard or paper to search for leaks. Do not use your hand.

1. Close fuel shut-off valve at bottom of fuel tank
2. Clean entire area surrounding fuel filter assembly to keep debris from entering fuel system.
3. Disconnect water in fuel sensor.
4. Drain fuel into a suitable container.
5. Firmly grasp the filter or filter housing and rotate it clockwise 1/4 turn. Remove ring with filter element (E).
6. Inspect filter mounting base for cleanliness. Clean as required.

NOTE: Raised locators on fuel filter canister must be indexed properly with slots in mounting base for correct installation.

7. Install new filter element onto mounting base. Be sure element is properly indexed and firmly seated on base. It may be necessary to rotate filter for correct alignment.
8. Align keys on filter element with slots in filter base.
9. Install retaining ring onto mounting base making certain dust seal is in place on filter base. Hand tighten ring (about 1/3 turn) until it “snaps” into the detent. DO NOT overtighten retaining ring.

NOTE: The proper installation is indicated when a “click” is heard and a release of the retaining ring is felt. A plug is provided with the new element for plugging the used element.

10. Connect water in fuel sensor.
11. Open fuel shut-off valve. Whenever the fuel system has been opened up for service (lines disconnected or filters removed), it will be necessary to bleed air from the system. (See BLEEDING THE FUEL SYSTEM on Page 63)

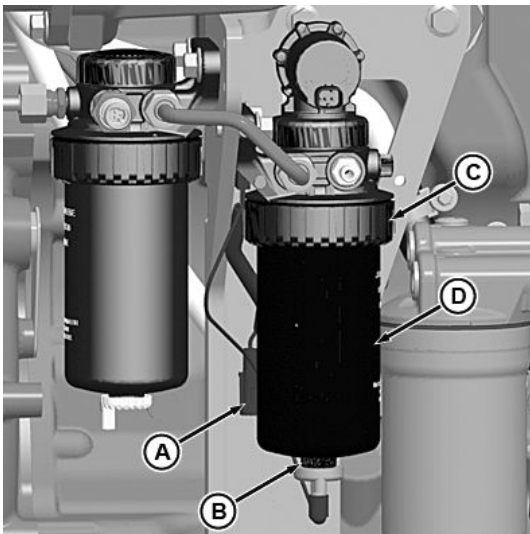

Location of electrical connector (A), drain (B), filter base (C), filter/water separator (D) - M50C13, M65C13, M99C13

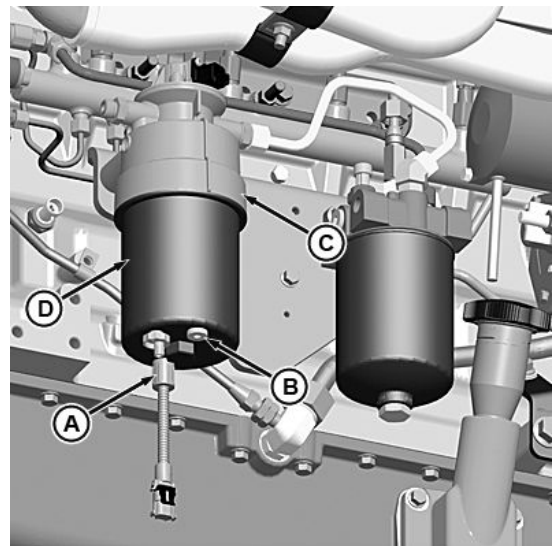

Location of electrical connector (A), drain (B), filter base (C), filter/water separator (D) - M150C13

---

## Service and Maintenance - 500 Hour

---

### SP 16. Checking Belt Tensioner Spring Tension and Belt Wear (Automatic Tensioner)

Belt drive systems equipped with automatic (spring) belt tensioners cannot be adjusted or repaired. The automatic belt tensioner is designed to maintain proper belt tension over the life of the belt. If tensioner spring tension is not within specification, replace tensioner assembly.

#### Checking Belt Wear

The belt tensioner is designed to operate within the limit of arm movement provided by the cast stops (A and B, below) when correct belt length and geometry is used. Visually inspect cast stops (A and B) on belt tensioner assembly.

If the tensioner cast stop (A) on swing arm is hitting either fixed cast stop (B), check mounting brackets (alternator, belt tensioner, idler pulley, etc.) and the belt length. Replace belt as needed (see REPLACING FAN AND ALTERNATOR BELTS on Page 61).

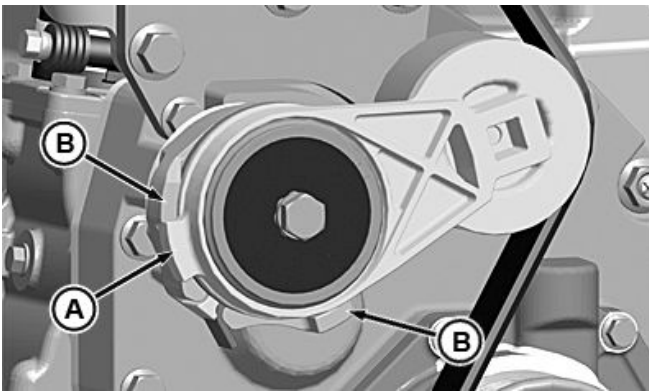

*Location of cast stops on tensioner arm - Tensioner cast stop (A) and Fixed Cast Stops (B)*



## Service and Maintenance - 500 Hour

### SP 17. Checking Tensioner Spring Tension

A belt tension gauge will not give an accurate measure of the belt tension when automatic spring tensioner is used. Measure tensioner spring tension using a torque wrench and procedure outlined below:

1. Release tension on belt using a long handled 1/2 inch drive tool in square hole in tensioner arm. (Earlier tensioner arms have bolt in place of square hole, and require breaker bar with socket.) Remove belt from pulleys.

NOTE: While belt is removed, inspect pulleys and bearings. Rotate and feel for hard turning and listen for any unusual sounds. If pulleys or bearings need replacement, contact your Northern Lights dealer.

2. Release tension on tension arm and remove drive tool.
3. Put a mark (A, right) on swing arm of tensioner as shown.
4. Measure 21 mm (0.83 in.) from (A) and put a mark (B, right) on tensioner mounting base.
5. Install torque wrench (C, right) so that it is aligned with centers of pulley and tensioner. Rotate the swing arm using a torque wrench until marks (A and B) are aligned.
6. Record torque wrench measurement and compare with specification below. Replace tensioner assembly as required.

Specification:

Spring Tension—Torque.....18-22 N·m (13-16 lb-ft)

NOTE: Threads on belt tensioner roller cap screw are LEFT-HAND threads.

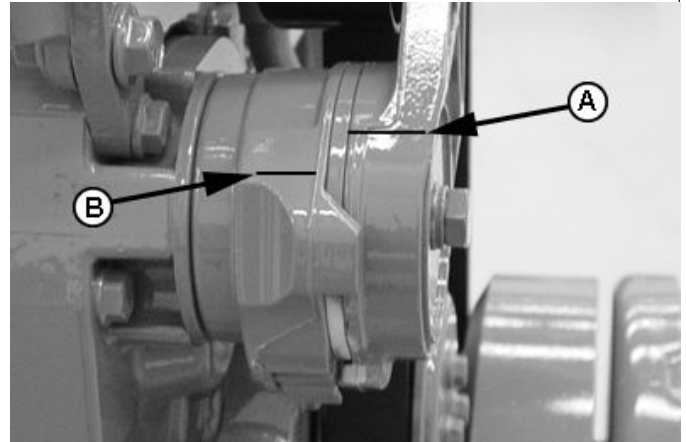

Marks on tensioner - Mark on swing arm (A), mark on tensioner mounting base (B)

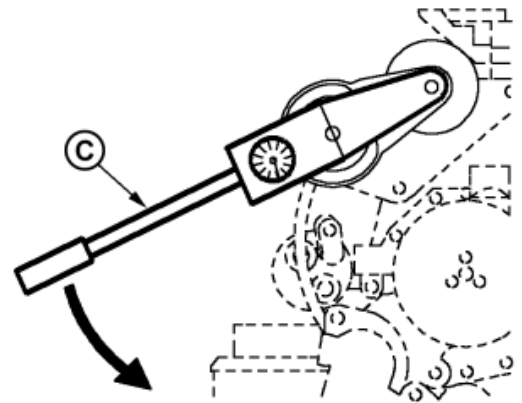

Align Torque Wrench (C) with Pulley

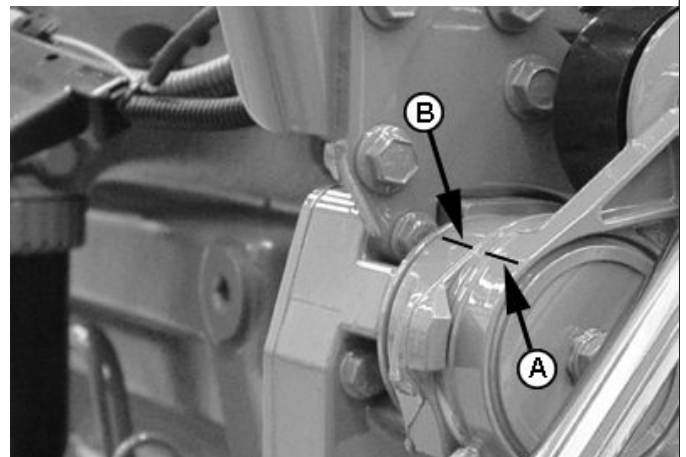

Align marks on tensioner - Swing arm (A), Tensioner mounting base (B)

## Service and Maintenance - 500 Hour

### SP 18. Checking Cooling System

#### **CAUTION**

Explosive release of fluids from pressurized cooling system can cause serious burns. Shut off engine. Only remove filler cap when cool enough to touch with bare hands. Slowly loosen cap to first stop to relieve pressure before removing completely.



IMPORTANT: Air must be expelled from cooling system when system is refilled. Loosen temperature sending unit fitting at rear of cylinder head or plug in thermostat housing to allow air to escape when filling system. Retighten fitting or plug when all the air has been expelled.

1. Check entire cooling system for leaks. Tighten all clamps securely.
2. Thoroughly inspect all cooling system hoses when hard, flimsy or cracked.

### SP 19. Replenishing Supplemental Coolant Additives (SCAs) Between Coolant Changes

NOTE: If system is to be filled with coolant that does not contain SCAs, the coolant must be precharged. Determine the total system capacity and premix with 3% Coolant Conditioner.

Through time and use, the concentration of coolant additives is gradually depleted during engine operation. Periodic replenishment of inhibitors is required, even when COOL-GARD® is used. The cooling system must be recharged with additional supplemental coolant additives (SCA) available in the form of liquid coolant conditioner.

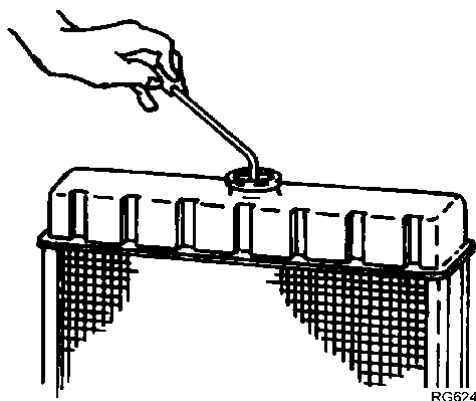

Coolant check

RG624

Maintaining the correct coolant conditioner concentration (SCAs) and freeze point is essential in your cooling system to protect against rust, liner pitting and corrosion, and freeze-ups due to incorrect coolant dilution.

DO NOT mix one brand of SCA with a different brand. Test the coolant solution at 500 hours or 12 months of operation using either coolant test strips or a COOLSCAN® or COOLSCAN PLUS® analysis. If a COOLSCAN® or COOLSCAN PLUS® analysis is not available, recharge the system per instructions printed on label of Liquid Coolant Conditioner.

IMPORTANT: ALWAYS maintain coolant at correct level and concentration. DO NOT operate engine without coolant even for a few minutes.

If frequent coolant makeup is required, the glycol concentration should be checked with a Coolant Tester to ensure that the desired freeze point is maintained.

When adding an SCA, DO NOT add more than the recommended amount.

The use of non-recommended SCA's may result in additive drop-out and gelation of the coolant.

If other coolants are used, consult the coolant supplier and follow the manufacturer's recommendation for use of SCA's.

See DIESEL ENGINE COOLANTS AND SUPPLEMENTAL ADDITIVE INFORMATION for proper mixing of coolant ingredients before adding to the cooling system.

#### Testing Diesel Engine Coolant

Maintaining adequate concentrations of glycol and inhibiting additives in the coolant is critical to protect the engine and cooling system against freezing, corrosion, and cylinder liner erosion and pitting.

Test the coolant solution at intervals of 12 months or less and whenever excessive coolant is lost through leaks or overheating.

#### Coolant Test Strips

Coolant test strips provide a simple, effective method to check the freeze point and additive levels of your engine coolant.

Compare the results to the supplemental coolant additive (SCA) chart to determine the amount of inhibiting additives in your coolant and whether more coolant conditioner should be added.

## Service and Maintenance - 500 Hour

### SP 20. Remove, Inspect and Clean Engine Heat Exchanger Core

**IMPORTANT:** Initially remove and inspect the engine heat exchanger core at 250 hour or three month service interval on a new engine. Then, remove and clean at every 500 hour or 12 month interval thereafter.

1. Close sea cocks and drain the sea water system.
2. Open drain cock on cylinder block and drain approximately two gallons of engine coolant into a clean container. Close drain cock.
3. Loosen hose clamp (A, below) and remove hose from rear end cap (B, below).
4. Remove two end cap mounting cap screws and remove end cap (C, below) with heat exchanger core (D, below) from rear of engine.

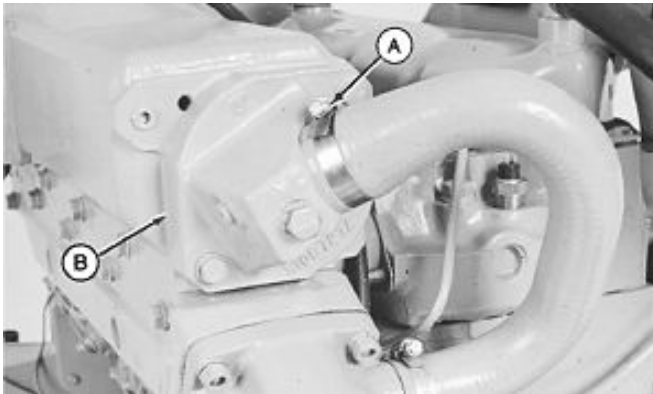

Heat exchanger - hose clamp (A), end cap (B)

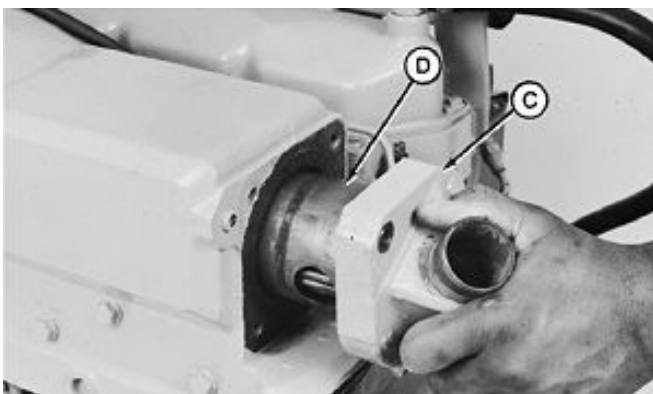

Heat exchanger disassembled - end cap (C), exchanger core (D)

**NOTE:** The heat exchanger core may be removed from housing when either end cap is removed. It is strongly recommended that both end caps be removed for cleaning when cleaning the heat exchanger core.

5. Remove remaining end cap from water manifold/heat exchanger housing. Remove end cap from heat exchanger core.
6. Thoroughly clean all buildup from both end caps and inspect zinc plug in each. Replace plugs as needed. (See **INSPECT AND REPLACE ZINC PLUGS** in 250 Hour Section.)
7. Use a 4.76 mm (3/16 in.) diameter brass rod to clean out any buildup in each heat exchanger tube. Run the rod the entire length of each tube to push debris out (below).



8. Flush the heat exchanger tubes with clean water, making sure all tubes are cleared of debris. Clean (with brass rod) and flush heat exchanger again if necessary to remove any remaining debris from tubes.

If you suspect that your heat exchanger core is defective, have your authorized servicing dealer or engine distributor pressure test for leaks. Replace heat exchanger core as required.

9. Remove and thoroughly clean water manifold/heat exchanger housing if needed.



---

## Service and Maintenance - 500 Hour

---

### Install Heat Exchanger Core

Thoroughly inspect condition of end cap sealing O-rings (A, below). Sealing O-rings may be reused if not excessively worn or damaged during disassembly. Replace sealing rings as necessary.

Lubricate front and rear end cap O-rings with clean multi-purpose grease.

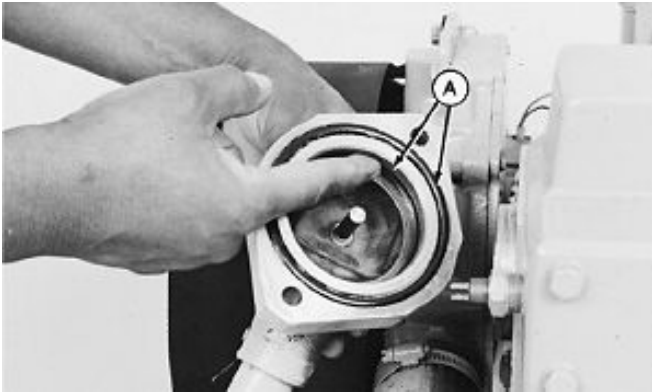

*Inspect heat exchanger end cap - O-rings (A)*

1. Install rear end cap, install cap screws and evenly tighten until end cap (B) is about 6.4 mm (0.25 in.) from housing (C). Index end cap in same position as removed.
2. Install heat exchanger core. Make sure core is properly seated in rear end cap to avoid cutting O-ring.
3. Install front end cap with heat exchanger core properly seated in cap and cap properly indexed in same position as removed.
4. Install and evenly tighten front end cap screws until cap contacts housing. Evenly tighten rear end cap screws until cap contacts housing. Tighten front and rear end cap screws to 24 N·m (18 lb-ft).
5. Connect all water piping and tighten hose clamps securely. Fill cooling system with the proper amount and concentration of ethylene-glycol base antifreeze.
6. Open sea cock, start engine and check for leaks.

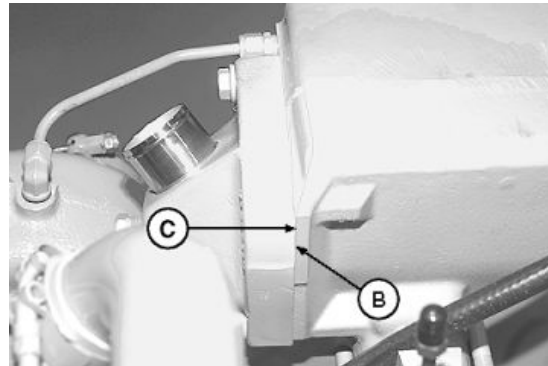

*Install heat exchanger - end cap (B), housing (C)*

## Service and Maintenance - 500 Hour

### Remove, Inspect and Clean Engine Aftercooler Core

**IMPORTANT:** Initially remove and inspect the aftercooler core at 250 hour or three month service interval on a new engine. Then, remove and clean at every 500 hour or 12 month interval thereafter.

**IMPORTANT:** Ensure that replacement seals and o-rings are readily available before removing aftercooler core. Air side seals will be destroyed during core removal.

1. Close sea cocks and drain the sea water system.
2. Loosen clamp (A, right) and remove air filter.
3. Loosen clamps (B, right), remove mounting bolt (C, right) and remove water line from rear of aftercooler.
4. Remove four cap screws (D, right) and remove rear cap and O-ring.
5. Remove clamps (E, right) and remove hoses from front cap.
6. Remove four cap screws (F, right), front cap and O-ring.
7. Remove aftercooler core from the rear of the engine.
8. Thoroughly clean all buildup from both end caps.
9. Use a 4.76 mm (3/16 in.) diameter brass rod to clean out any buildup in each tube. Run the rod the entire length of each tube to push debris out (below).
10. Flush the tubes with clean water, making sure all tubes are cleared of debris. Clean (with brass rod) and flush aftercooler core again if necessary to remove any remaining debris from tubes.

If you suspect that your aftercooler core is defective, have your authorized servicing dealer or engine distributor pressure test for leaks. Replace aftercooler core as required.



*Aftercooler core cleaning*



*Clamp (A) and air filter*

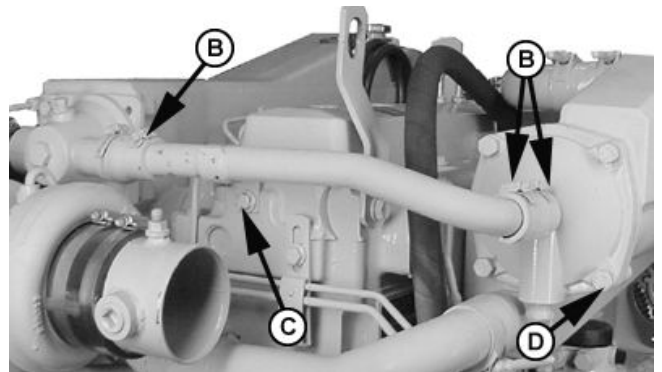

*Rear clamp removal - Clamps (B), Mounting bolt (C), Cap screws (D)*

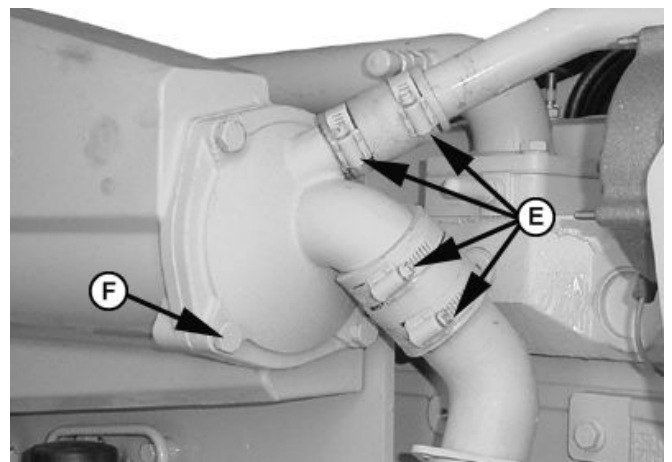

*Front clamp removal - Clamps (E), Cap screws (F)*

## Service and Maintenance - 500 Hour

### SP 21. Pressure Testing Cooling System

#### **CAUTION**

Explosive release of fluids from pressurized cooling system can cause serious burns. Shut off engine. Only remove filler cap when cool enough to touch with bare hands. Slowly loosen cap to first stop to relieve pressure before removing completely.

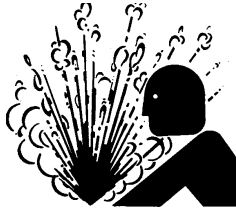

#### Test Coolant Filler Cap

1. Remove coolant filler cap and attach to an appropriate tester as shown (right).
2. Pressurize cap to 10kPa (1.1 bar) (16 psi) . Gauge should hold pressure for 10 seconds within the normal range if cap is acceptable.

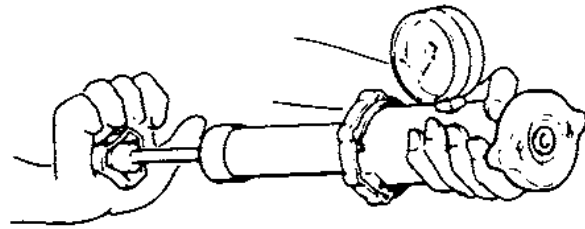

*Coolant filler cap tester*

If gauge does not hold pressure, replace pressure cap.

3. Remove the cap from gauge, turn it 180°, and retest cap. This will verify that the first measurement was accurate.

#### Test Cooling System

NOTE: Engine should be warmed up to test overall cooling system.

1. Allow engine to cool, then carefully remove coolant filler cap.
2. Fill tank with coolant to the normal operating level.

IMPORTANT: DO NOT apply excessive pressure to cooling system, doing so may damage coolant tank and hoses.

3. Connect gauge and adapter to filler neck, as shown (right). Pressurize cooling system to 110kPa (16 psi).
4. With pressure applied, check all cooling system hose connections, coolant tank, and overall engine for leaks.

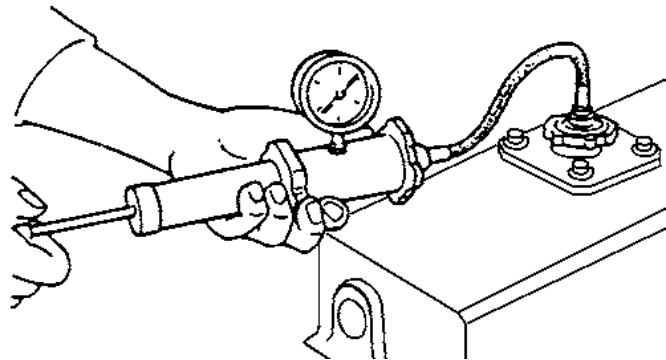

*Cooling system/radiator test*

If leakage is detected, correct as necessary and pressur test system again.

If no leakage is detected, but the gauge indicated a drop in pressure, coolant may be leaking internally within the system or at the block-to-head gasket. Have your servicing dealer correct this problem immediately.

## Service and Maintenance - 500 Hour

### SP 22. Flushing and Refilling Cooling System

#### **CAUTION**

Explosive release of fluids from pressurized cooling system can cause serious burns. Shut off engine. Only remove filler cap when cool enough to touch with bare hands. Slowly loosen cap to first stop to relieve pressure before removing completely.



Drain old coolant, flush the entire cooling system, test thermostats (page 50), and fill with recommended clean coolant using the following procedure.

1. Pressure test entire cooling system and pressure cap if not previously done. (See PRESSURE TESTING COOLING SYSTEM, on page 44.)
2. Slowly open the cap on the top tank (A, below) or heat exchanger to relieve pressure and allow coolant to drain faster.

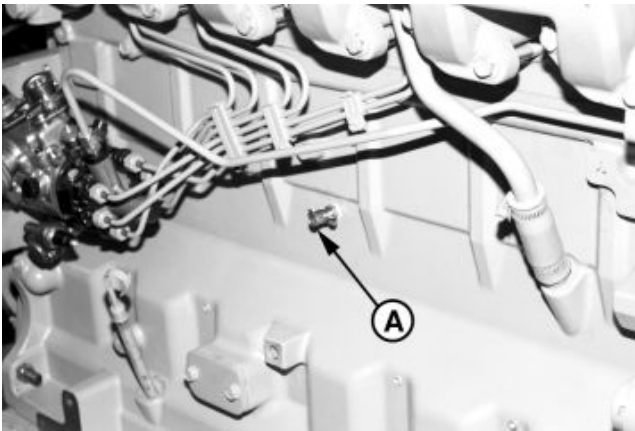

Engine block drain valve (A)

3. Open engine block drain valve (A) on left side of engine. Drain all coolant from engine block.
4. Open heat exchanger or top tank drain valve. Drain all coolant from heat exchanger or top tank.
5. Remove thermostats at this time, if not previously done. Install cover (without thermostats) using old gasket and tighten cap screws to 47 N·m (35 lb-ft).
6. Test thermostat opening temperature. (See Inspecting Thermostats And Testing Opening Temperature on Pages 49-50).

7. Close all drain valves after coolant has drained.

#### **CAUTION**

Do not run engine longer than 10 minutes. Doing so may cause engine to overheat, causing burns when cooling system is draining.

8. Fill the cooling system with clean water. Run the engine about 10 minutes to stir up possible rust or sediment.
9. Stop engine, pull off lower cooling system hose and remove heat exchanger or top tank cap. Immediately drain the water from system before rust and sediment settle.
10. After draining water, close drain valves. Reinstall cap, lower cooling system hose and clamp. Fill the cooling system with clean water and a heavy duty cooling system cleaner such as Fleetguard® RESTORE™ and RESTORE PLUS™.
11. After cleaning the cooling system, drain cleaner and fill with water to flush the system. Run the engine about ten minutes, remove heat exchanger or top tank cap and pull off lower cooling system hose to drain out flushing water.
12. Close all drain valves. Reinstall hoses and tighten clamps securely. Install thermostats using a new gasket.

### SP 23. Checking Engine Electrical Ground Connections

Keep all engine ground connections clean and tight to prevent electrical arcing which can damage electronic components.

## Service and Maintenance - 2000 Hour

### SP24. Checking and Adjusting Engine Valve Clearance

#### **CAUTION**

To prevent accidental starting of engine while performing valve adjustments, always disconnect NEGATIVE (—) battery terminal.

**IMPORTANT:** Valve clearance **MUST BE** checked and adjusted with engine **COLD**.

1. Remove rocker arm cover and crankcase ventilator tube.

**IMPORTANT:** Visually inspect contact surfaces of valve tips, bridges and rocker arm wear pads. Check all parts for excessive wear, breakage, or cracks. Replace parts that show visible damage.

Rocker arms that exhibit excessive valve clearance should be inspected more thoroughly to identify damaged parts.

2. Remove plastic plugs or cover plate from engine timing/rotation hole (A, below) and timing pin hole

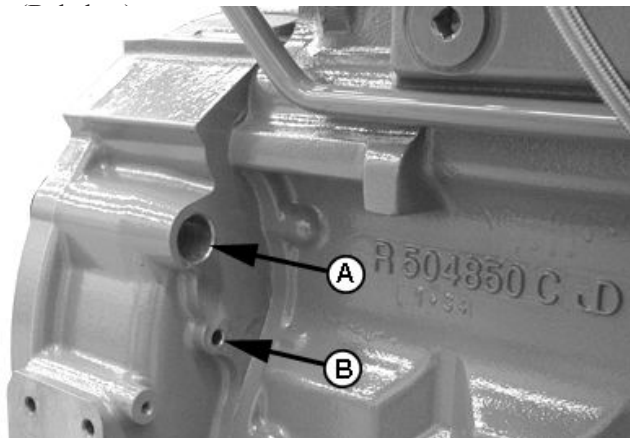

*Flywheel housing timing holes - timing/rotation hole (A), timing pin hole (B)*

3. Using flywheel turning tool, rotate engine flywheel in running direction (clockwise viewed from front) until No. 1 (front) cylinder is at TDC compression stroke. Insert Timing Pin in flywheel.

If No. 1 cylinder rocker arms are loose, the engine is at No. 1 TDC compression.

If No. 1 cylinder rocker arms are not loose, rotate engine one full revolution (360°) to No. 1 TDC compression.

4. Adjust valves to specifications below using the valve clearance adjustment procedure in the following blocks. Loosen the jam nut on rocker arm adjusting screw. Turn adjusting screw until feeler gauge slips with a slight drag. Hold the adjusting screw from turning with screwdriver and tighten jam nut to specifications (below). Recheck clearance again after tightening jam nut. Readjust clearance as necessary.

#### Specifications

##### Intake Valve Clearance Adjustment

(Rocker Arm-to-Bridge / Engine Cold)

Clearance..... 0.36 mm (0.014 in.)

##### Exhaust Valve Clearance Adjustment

(Rocker Arm-to-Bridge / Engine Cold)

Clearance..... 0.46 mm (0.018 in.)

##### Rocker Arm Adjusting Screw Jam Nut

Torque..... 27 N·m (20 lb-ft)

5. Install rocker arm cover and crankcase ventilator tube.
6. Reconnect battery terminal.



## Service and Maintenance - 2000 Hour

### 4-Cylinder Engine (M50C13, M65C13, M99C13)

NOTE: Firing order is 1-3-4-2.

Lock No. 1 piston at TDC compression stroke (B, right).

Adjust valve clearance on No. 1 and 3 exhaust valves and No. 1 and 2 intake valves.

Rotate flywheel 360°. Lock No. 4 piston at TDC compression stroke (C, right).

Adjust valve clearance on No. 2 and 4 exhaust valves and No. 3 and 4 intake valves.

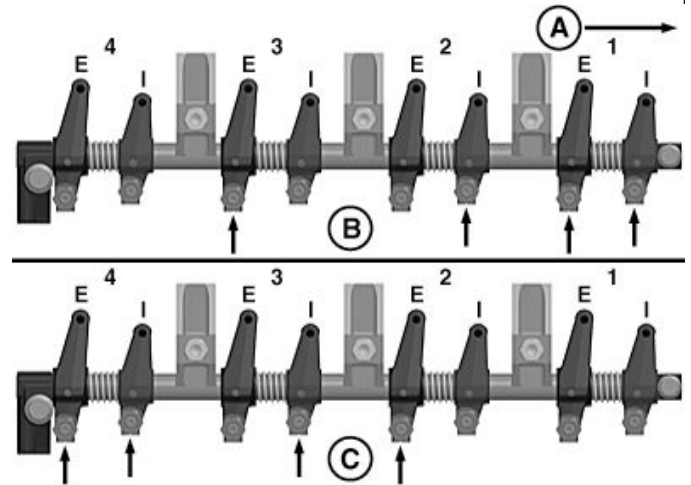

4 cylinder valve adjustment (M50C13, M65C13, M99C13) - Front of engine (A), No. 1 piston at TDC compression stroke (B), No. 4 piston at TDC compression stroke (C), exhaust valve (E), intake valve (I)

### 6-Cylinder Engine (M150C13)

NOTE: Firing order is 1-5-3-6-2-4.

Lock No. 1 piston at TDC compression stroke (B, right).

Adjust valve clearance on No. 1, 3 and 5 exhaust valves and No. 1, 2 and 4 intake valves.

Rotate flywheel 360°. Lock No. 6 piston at TDC compression stroke (C, right).

Adjust valve clearance on No. 2, 4 and 6 exhaust valves and No. 3, 5 and 6 intake valves.

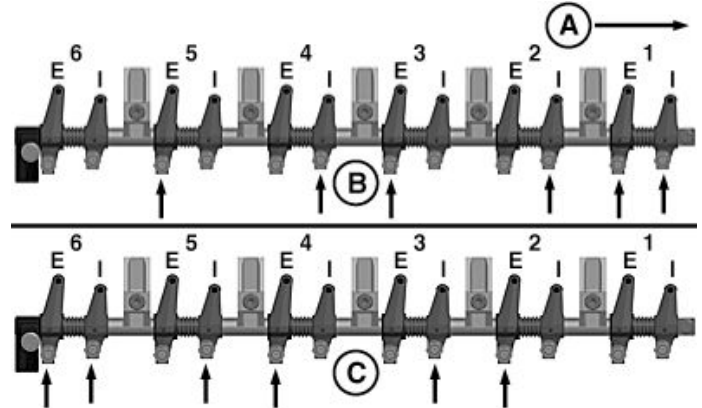

6 cylinder valve adjustment (M150C13) - Front of engine (A), No. 1 piston at TDC compression stroke (B), No. 6 piston at TDC compression stroke (C), exhaust valve (E), intake valve (I)



---

## Service and Maintenance - 2000 Hour

---

### SP 25. Checking Crankshaft Vibration Damper (M150C13 Only)

1. Remove belts (shown removed).
2. Grasp vibration damper with both hands and attempt to turn it in both directions. If rotation is felt, damper is defective and should be replaced.

**IMPORTANT:** The vibration damper assembly is not repairable. Replace damper every 4500 hours or 60 months, whichever occurs first.

3. Check vibration damper radial runout by positioning a dial indicator (A) so probe contacts damper outer diameter.
4. With engine at operating temperature, rotate crankshaft using Flywheel Turning Tool.
5. Note dial indicator reading. If runout exceeds 1.50 mm (0.060 in.) replace vibration damper.

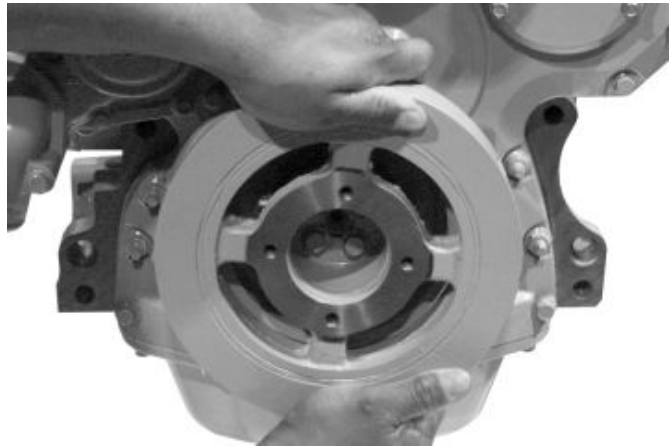

*Grasp vibration damper*

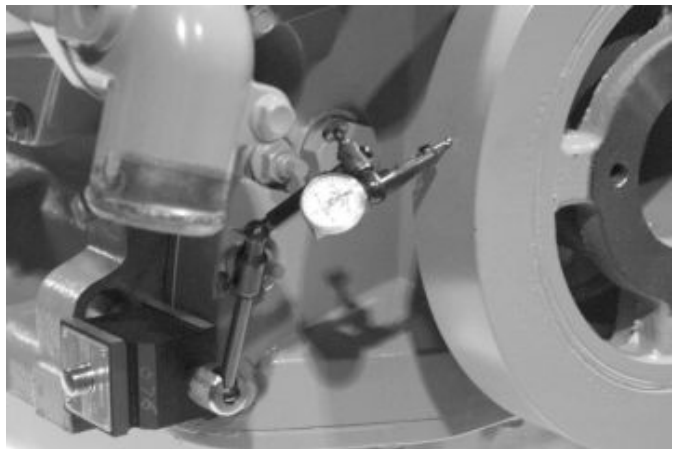

*Check runout*

## Service and Maintenance - 2000 Hour

### SP 26: Remove Thermostats

#### **CAUTION**

Explosive release of fluids from pressurized cooling system can cause serious burns. Shut off engine. Only remove filler cap when cool enough to touch with bare hands. Slowly loosen cap to first stop to relieve pressure before removing completely.



1. Visually inspect area around thermostat housing and cover for leaks.
2. Remove coolant tank pressure cap and partially drain coolant system.
3. Remove cap screws (A), nut (B) and washer (C) attaching coolant cover (D) with sealing O-ring (E) to the thermostat housing (G) and exhaust manifold.
4. Remove cap screws (F) attaching thermostat housing to the exhaust manifold.
5. Remove thermostat housing with gasket (I). Remove and discard all gasket material. Clean all sealing surfaces.
6. Inspect and test thermostats for proper opening temperature.
7. Install thermostats with a new gasket and pilot housing on stud (J). Install thermostat housing cap screws finger-tight.
8. Inspect thermostat cover sealing O-ring and replace if necessary. Install thermostat cover with O-ring, cap screws, washer and nut. Tighten nut and all cap screws to 35 N-m (25 lb.-ft.)

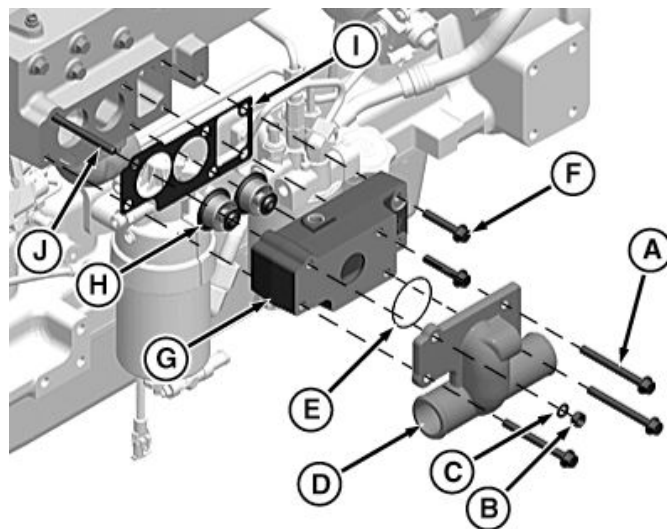

*Thermostat removal and installation:*

- A - Cap screws (thermostat cover)*
- B - Nut*
- C - Washer*
- D - Thermostat cover*
- E - O-ring*
- F - Cap screws (thermostat housing)*
- G - Thermostat housing*
- H - Thermostats*
- I - Gasket*
- J - Stud*

## Service and Maintenance - 2000 Hour

### Inspecting Thermostats and Testing Opening Temperature

1. Remove thermostats. (page 49.)
2. Visually inspect thermostats for corrosion or damage. Replace thermostats as a matched set as necessary.
3. Inspect thermostat with wiggle wire in vent notch. If wire movement is restricted, replace thermostat if cleaning does not free movement.

### **CAUTION**

**DO NOT allow thermostat or thermometer to rest against the side or bottom of container when heating water. Either may rupture if overheated.**

4. Suspend thermostats and a thermometer in a container of water.
5. Stir the water as it heats. Observe opening action of thermostat and compare temperatures with specifications. See GENERAL ENGINE SPECIFICATIONS on Pages 72-73.

NOTE: Due to varying tolerances of different supplies, initial opening and full open temperatures may vary slightly from specified temperatures.

6. Remove thermostat and observe its closing action as it cools. In ambient air the thermostat should close completely. Closing action should be smooth and slow.
7. If any one thermostat is defective, replace both thermostats.

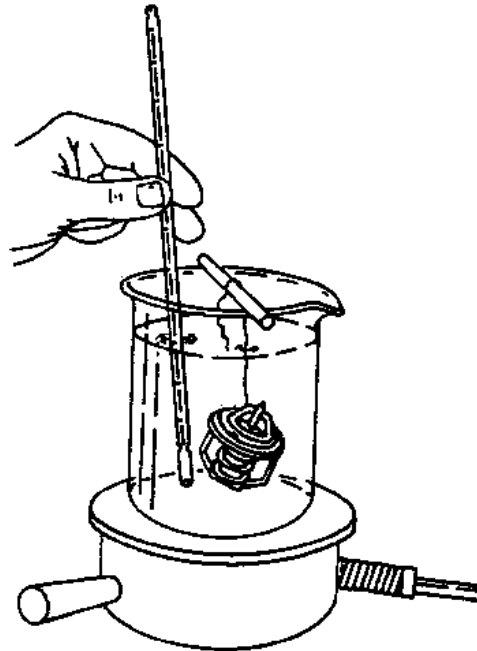

*Thermostat and thermometer in water*

## Service and Maintenance - 2000 Hour

### SP 27. Inspect and Repair Sea Water Pump (M50C13, M65C13, M99C13)

- Inspect pump housing for seal leakage

1. Inspect the sea water pump housing weep hole, if equipped, for evidence of water or oil indicating seal leakage. If water leakage is evident, replace impeller and front housing/shaft seal.

If oil leakage is evident, consult an authorized Northern Lights dealer for repair.

#### Remove and Inspect Impeller

1. Close sea cock and drain sea water system if not previously done.
2. Remove six cover plate cap screws with washers and remove cover plate (A) with O-ring. Remove impeller end cap from end of impeller bore.

NOTE: Normally the impeller can be removed by using two pair of pliers to grip impeller vanes on opposite sides of impeller. Rotating the pump shaft by hand may help free the impeller. Petroleum based lubricants can cause the impeller to swell, and are not recommended to free a stuck impeller.

3. Carefully remove impeller with cam plate. Be careful not to damage impeller if in reusable condition. Remove key from shaft keyway.

The impeller must be installed in the same direction as removed. Mark the impeller to ensure installation in proper direction of rotation if impeller is reused.

4. Inspect impeller for damages such as tears, stress cracks, excess abrasions on vane ends, or chunks of material missing. Impellers that are run dry will overheat and fail the impeller blades at the root. Impellers that swell and stick, fail the impeller in the middle of the blade.

**IMPORTANT:** If impeller has chunks of material missing, the heat exchanger, marine gear oil cooler and any other circuit that are cooled by raw water should be thoroughly cleaned and flushed.

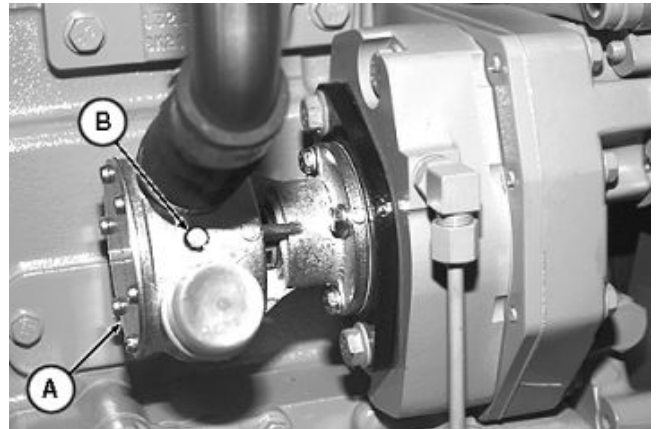

Remove cover plate. Cover plate (A), Cam screw (B)

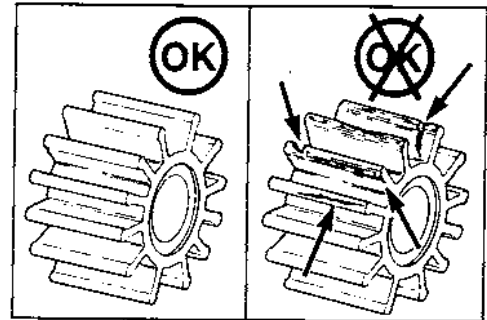

Inspect sea water pump impeller

5. Remove cam screw (B) holding cam plate to impeller housing bore.
6. Thoroughly clean impeller housing bore and cam plate (if cam plate is reused.)

## Service and Maintenance - 2000 Hour

### SP 27. Inspect and Repair Sea Water Pump (M150C13)

- Inspect pump housing for seal leakage

1. Inspect the sea water pump housing weep hole, if equipped, for evidence of water or oil indicating seal leakage. If water leakage is evident, replace impeller and front housing/shaft seal.

If oil leakage is evident, consult an authorized Northern Lights dealer for repair.

#### Remove and Inspect Impeller

1. Close sea cocks and drain sea water system.
2. Remove cover plate (A) from sea water pump.

NOTE: Special impeller puller tool is provided with sea water pump rebuild kits. If tool is not available, the impeller can normally be removed by using two pair of pliers to grip impeller vanes on opposite sides of impeller. Rotating the pump shaft by hand may help free the impeller.

Petroleum based lubricants can cause the impeller to swell, and are not recommended to free a stuck impeller.

3. Remove impeller (B) and shaft key (C) (if equipped) from pump housing.
4. Remove O-ring (D).
5. Inspect cam plate (E) for evidence of heavy pitting or wear. Replace as needed.
6. Inspect impeller for damages such as tears, stress cracks, excess abrasions on vane ends, or chunks of material missing. Impellers that are run dry will over heat and fail the impeller blades at the root. Impellers that swell and stick, fail the impeller in the middle of the blade. If impeller replacement is necessary, order an impeller repair kit.

**IMPORTANT:** If impeller has chunks of material missing, the heat exchanger, aftercooler, marine gear oil cooler and any other circuit that are cooled by raw water should be thoroughly cleaned and flushed.

7. Install shaft key (C) (if equipped) on shaft.
8. Lubricate new impeller blades with a non-petroleum based lubricant such as silicone or soapy water. Install impeller using a twisting motion and be sure the impeller blades are bent in the same direction as they were upon removal to prevent damage at startup. Rotate impeller on shaft to align keyways/splines and slide the impeller onto the shaft.

Remove cover plate (A)

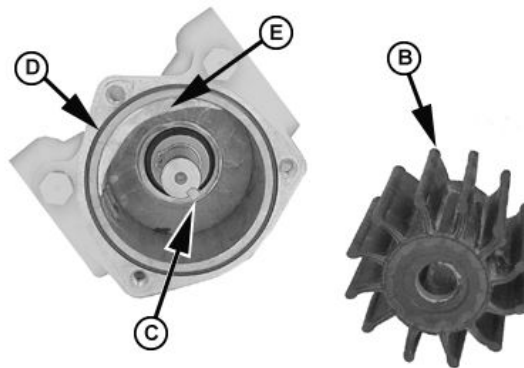
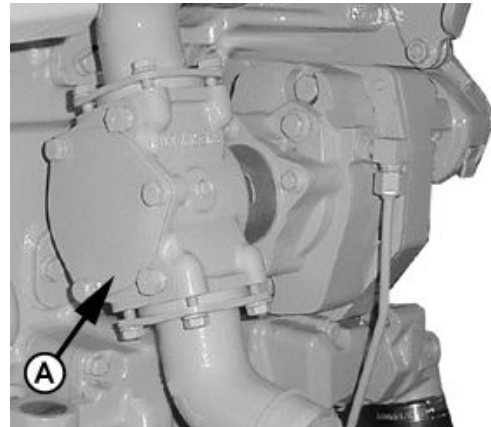

Remove and inspect components. Impeller (B), Shaft key (C), O-ring (D), Cam plate (E)

Inspect sea water pump impeller

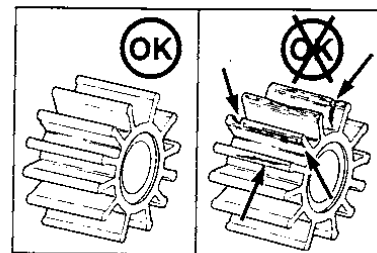

9. Using a new O-ring (D), install cover plate and tighten cap screws with washers securely.
10. Install sea water pump and tighten cap screws to 73 N·m (54 lb-ft).
11. Connect sea water inlet and outlet tubes. Tighten mounting cap screws evenly until secure.
12. Replace O-rings on oil tubes and install oil filter housing and oil tubes. Tighten mounting cap screws to 35 N·m (26 lb-ft).
13. Open sea cocks, start engine and check pump operation.

## Service and Maintenance - As Required

### Remove and Install Sea Water Pump (M50C13, M65C13, M99C13)

NOTE: Sea water pump may have two more mounting cap screws than illustrated. Remove/install procedure is unchanged.

#### • Remove Sea Water Pump:

1. Close sea cock and drain sea water system.
2. Remove water inlet tube (shown removed) and outlet tube (A) from sea water pump.
3. Remove two cap screws (B) attaching sea water pump to gear housing. Withdraw pump from housing until splined shaft (C) is free from splined drive gear ID (D).
4. Clean all gasket material from both mating surfaces.

#### • Install Sea Water Pump:

1. Position a new gasket on water pump mounting flange. Install splined pump shaft in splined ID of drive gear.
2. Align mounting holes in water pump flange and gasket with threaded holes in gear housing. Install cap screws with washers and tighten cap screws to 47 N•m (35 lb-ft).
3. Connect water piping and tighten clamps.
4. Open sea cock, start engine, and check for leaks.

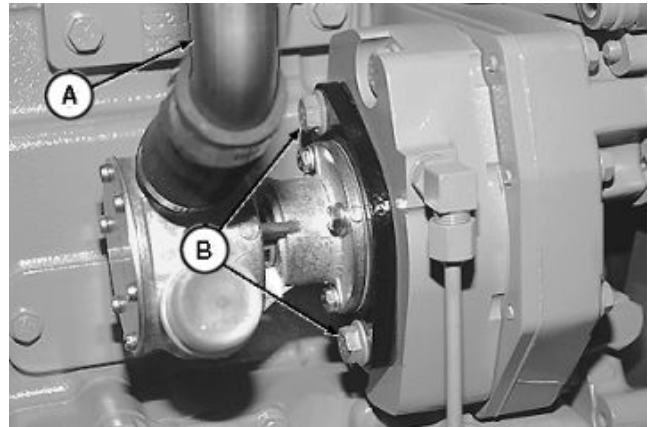

*Remove sea water pump.  
Outlet tube (A), Mounting screws (B)*



*Install sea water pump.  
Splined shaft (C), Drive Gear Splined ID (D)*



## Service and Maintenance - As Required

### Remove And Install Sea Water Pump

1. Close sea cock and drain sea water system.
2. Remove sea water outlet connection (A), remove sea water pump cap screws (B) and remove pump.
3. Clean all gasket material from both mating surfaces.
4. Inspect gear teeth for damage. Install new gear (D) by aligning key (C) to the pump shaft keyway.
5. Install lock washer (E) and hex nut (F) finger-tight and insure key is properly in place.
6. Tighten hex nut to 68 N·m (50 lb.-ft.).
7. Install sea water pump with new gasket to front plate and tighten cap screws (B) to 140 N·m (103 lb.-ft.).
8. Connect sea water inlet and outlet.
9. Open sea cock, start engine and check for leaks.

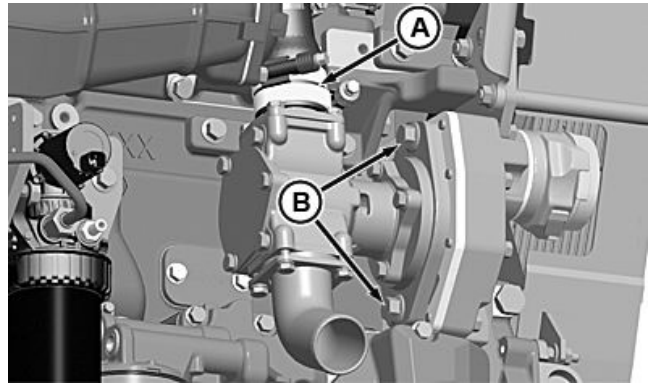

*Remove and install sea water pump.  
Sea water outlet (A), Cap screws (B)*

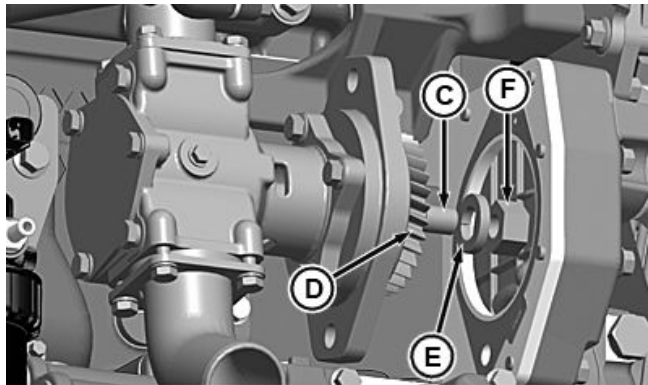

*Sea water pump.  
Key (C), Gear (D), Lock washer (E), Hex nut (F)*

## Service and Maintenance - As Required

### Remove and Install Sea Water Pump (M150C13)

1. Close sea cock and drain sea water system.
2. Remove sea water pump inlet connection. Loosen constant tension clamps (B) on formed hose (C) that is attached to the aftercooler inlet (A).
3. Remove sea water pump bracket cap screws (D). Remove pump mounting nuts (E) and remove sea water pump (H).
4. Clean sealing surfaces and inspect for defects. Replace O-ring (G) if necessary.
5. Install sea water pump with O-ring on studs (F). Install nuts (E) finger-tight evenly on both studs and tighten to 60 N·m (44 lb.-ft.).
6. Install bracket cap screws (D) and tighten to 35 N·m (26 lb.-ft.)
7. Install formed hose (C) and tighten constant tension clamps (B) to 12 N·m (9 lb.-ft.).
8. Connect sea water pump inlet.
9. Open sea cock, start engine and check for leaks.

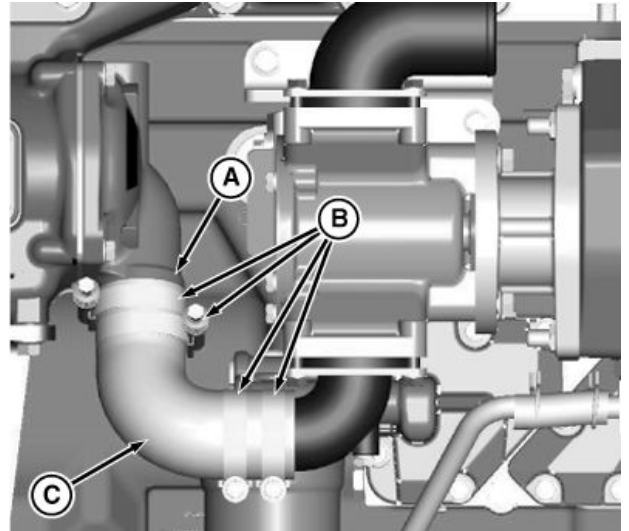

Remove and install sea water pump  
Aftercooler inlet (A), Constant tension clamps (B),  
Formed hose (C)

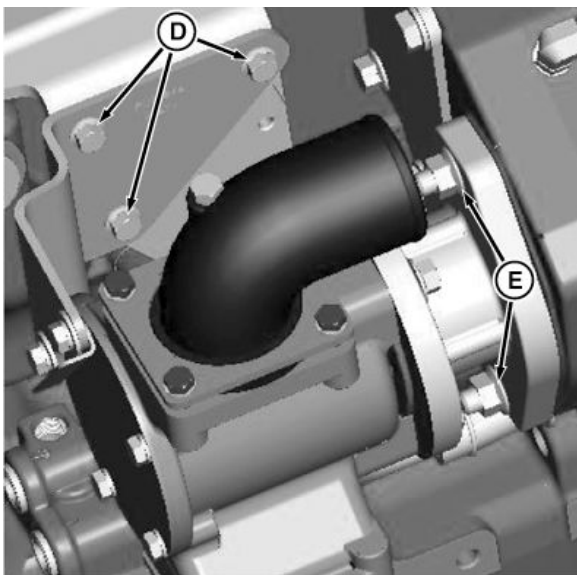

Cap screws (D), Nuts (E)

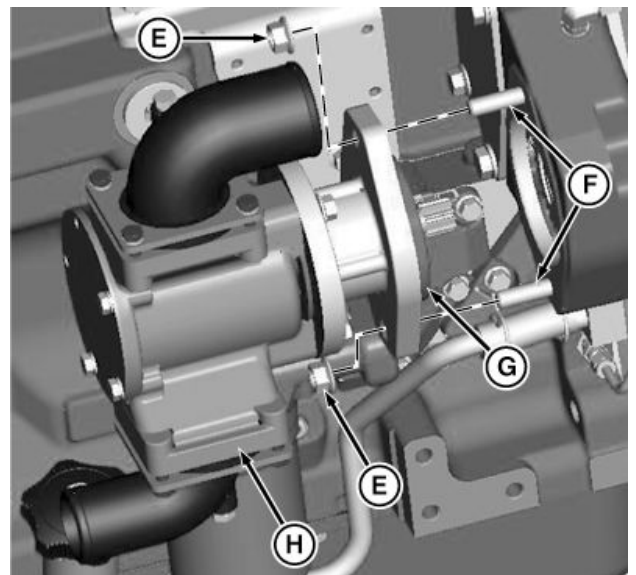

Nuts (E), Studs (F), O-ring (G), Seawater pump (H)

---

## Service and Maintenance - As Required

---

### Install Impeller

1. Apply LOCTITE® 242 to curved side of cam plate near threaded hole and install cam plate into impeller housing bore, be sure holes in cam plate and housing are aligned. Apply LOCTITE® 242 to cam screw (B), install, and tighten.

The cam plate should be inspected to insure that none of the cam fingers are protruding which could cause impeller damage. The cam screw should also be inspected to insure that it does not protrude below the cam plate. Replace cam plate and cam screw or grind screw flush as needed.

**IMPORTANT:** Petroleum based lubricants can cause the impeller to swell, and are not recommended to lubricate the impeller before installation.

2. Lubricate impeller blades with a non-petroleum based lubricant such as silicone or soapy water. Install impeller using a twisting motion and be sure the impeller blades are bent in the same direction as they were upon removal.

Be sure impeller is installed in same direction as removed if reusing existing impeller.

3. Rotate impeller to align keyway and slide the key in place. Install impeller end cap in end of impeller bore.
4. Using a new O-ring, install cover plate (A) onto impeller housing. Install six screws with washers. Tighten screws evenly.
5. Reconnect all water piping, if disconnected.
6. Open sea cock and prime sea water pump with water. Start engine and check for leaks.

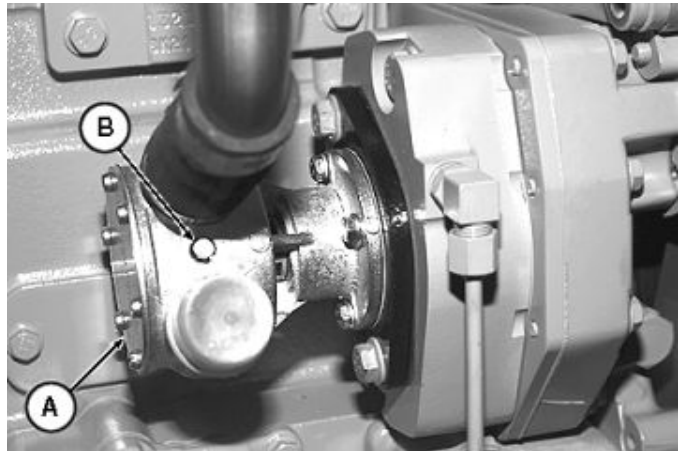

*Install cover plate. Cover plate (A), Cam screw (B)*

## Service and Maintenance - As Required

### Do Not Modify Fuel System

**IMPORTANT:** Modification or alteration of the injection pump (arrow), the injection pump timing, or the fuel injectors in ways not recommended by the manufacturer will terminate the warranty obligation to the purchaser.

In addition, tampering with fuel system which alters emission-related equipment on engines may result in fines or other penalties, per EPA regulations or other local emission laws.

Do not attempt to service injection pump or fuel injectors yourself. Special training and special tools are required. (See your authorized Northern Lights servicing dealer.)

**IMPORTANT:** Never steam clean or pour cold water on a high-pressure fuel pump while it is still warm. To do so may cause seizure of pump parts.

### SP 29. Adding Coolant

#### CAUTION

Explosive release of fluids from pressurized cooling system can cause serious burns.

Shut off engine. Only remove filler cap when cool enough to touch with bare hands. Slowly loosen cap to first stop to relieve pressure before removing completely.



**IMPORTANT:** Never pour cold liquid into a hot engine, as it may crack cylinder head or block. DO NOT operate engine without coolant for even a few minutes.

Air must be expelled from cooling system when coolant is added.

1. Loosen temperature sending unit fitting at rear of cylinder head or plug in side of thermostat housing to allow air to escape when filling system.

**IMPORTANT:** When adding coolant to the system, use the appropriate coolant solution. (See page 25-26 for for mixing of coolant ingredients before adding to cooling system.)

Do not overfill cooling system. A pressurized system needs space for heat expansion without overflowing at top of coolant tank.

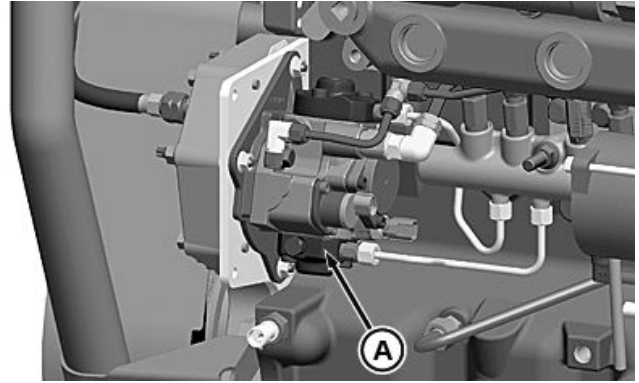

Location of fuel injection pump (A)

### SP 30. Servicing Air Cleaner Filter Element

**IMPORTANT:** Always service primary air cleaner element when air restriction indicator shows a vacuum of 625 mm (25 in.) H<sub>2</sub>O, or when reset button has popped up (M150C13 only).

Also replace element if it is torn, or visibly dirty.

NOTE: This procedure applies to Northern Lights air cleaner kits. Refer to manufacturers' instructions for servicing air cleaners not supplied by Northern Lights.

1. Loosen clamp (A) and remove filter element.

**IMPORTANT:** Replace filter element after 10 cleanings. (See page 58 for replacement instructions)

2. Tap end of filter GENTLY on hard surface to dislodge loose dirt.
3. Brush dirt side of filter GENTLY with soft bristle brush.

**IMPORTANT:** DO NOT clean element with gasoline, solvents, parts cleaners, strong detergents, or caustic cleaning solutions. DO NOT steam clean or use high-pressure washers to clean element. These processes will damage filter media and/or rubber base or end cap.

## Service and Maintenance - As Required

### Replacing Air Cleaner Filter Element

Replace element if it is torn, or visibly dirty.

NOTE: This procedure applies to Northern Lights air cleaner kits. Refer to manufacturers' instructions for servicing air cleaners not supplied by Northern Lights.



*Air cleaner restriction indicator*

1. Loosen clamp (A) and remove filter element.

**IMPORTANT:** Replace filter element after 10 cleanings. (See page 57 for replacement instructions)

2. Tap end of filter GENTLY on hard surface to dislodge loose dirt.
3. Brush dirt side of filter GENTLY with soft bristle brush.

**IMPORTANT:** DO NOT clean element with gasoline, solvents, parts cleaners, strong detergents, or caustic cleaning solutions. DO NOT steam clean or use high-pressure washers to clean element. These processes will damage filter media and/or rubber base or end cap.

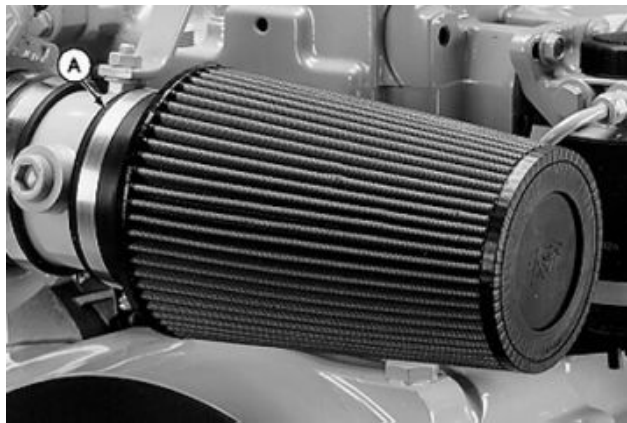

*Removal of air filter element (A)*

4. Spray air filter cleaner (B) liberally onto entire element. Let soak into filter media for 10 minutes.

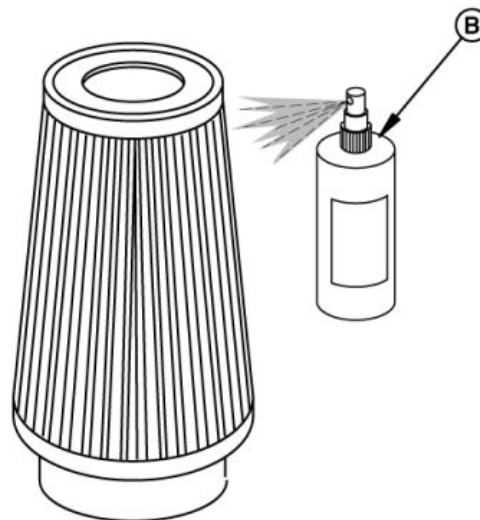

*Spray filter with cleaner (B)*



## Service and Maintenance - As Required

5. Rinse filter with low pressure water, flushing opposite the direction of air flow (from clean side to dirty side).

**IMPORTANT:** Let element dry at room temperature. Compressed air will damage filter media. Heat will shrink filter media and may damage rubber base or end cap.

6. Shake off excess water and let the element dry at room temperature.

**IMPORTANT:** Never put filter in service without oiling it. The filter will not function properly without oil.

Do not use automatic transmission fluid, motor oil, diesel fuel, or any type light-weight spray lubricant. These products will damage filter or degrade its performance.

**NOTE:** Red dye is added to oil to show areas of oil application.

7. Spray air filter oil from squeeze bottle (C) from distance of 25 cm (10 in.) onto a group of pleats until the pleats become reddish in color. Re-spray any areas that are still white 10 minutes after initial application.

8. Install filter and tighten clamp.



*Rinse filter*

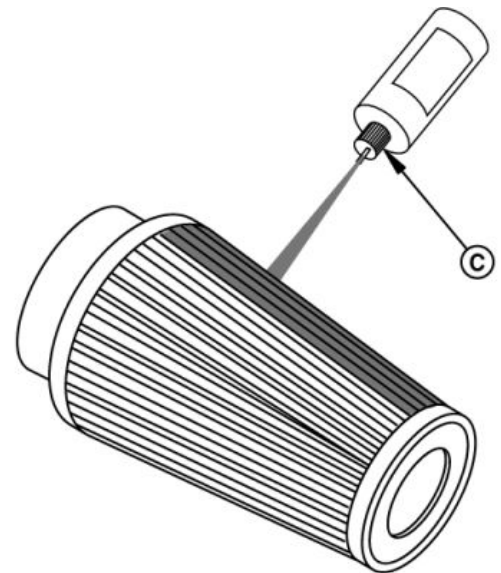

*Apply oil to filter*



---

## Service and Maintenance - As Required

---

### Replacing Air Cleaner Filter Element

**IMPORTANT:** Replace the element after 10 cleanings.

1. Loosen clamp (A) and remove filter element.
2. Install new filter element and tighten clamp.

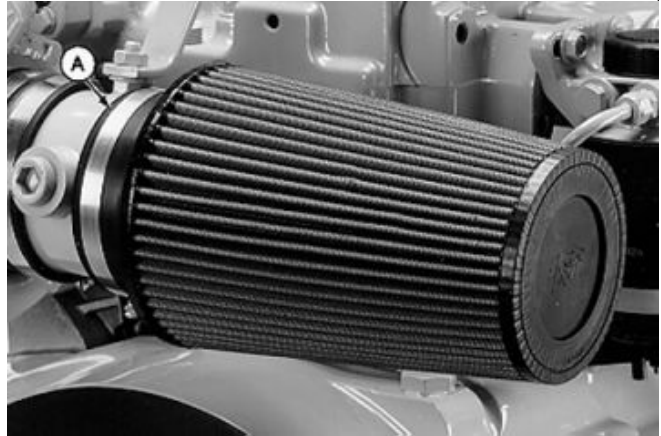

*Filter element*

### Replacing Dry Air Cleaner Element

**IMPORTANT:** ALWAYS REPLACE primary air cleaner element when air restriction indicator (A) shows vacuum of 625 mm (25 in.) H<sub>2</sub>O, or when reset button has popped up (if equipped). Also replace element if it is torn, or visibly dirty.

1. Release air filter assembly clamps (A) and remove cover.

**IMPORTANT:** Insure all air intake connections are secure to prevent ingestion of abrasive dirt and dust into the system, causing possible engine damage.

2. Install new air filter element (B), install cover and engage clamps.

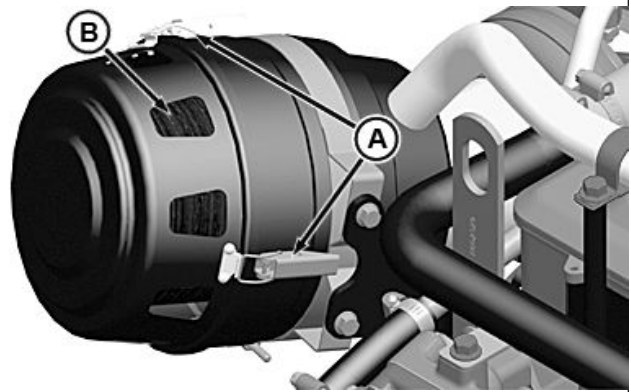

*Replace air filter element. Air filter assembly clamps (A), Air filter elements (B)*

## Service and Maintenance - As Required

### SP 31. Replacing Alternator Belt (With Automatic Tensioner)

Refer to CHECKING BELT TENSIONER SPRING TENSION AND BELT WEAR (page 38-39) for additional information on the belt tensioner.

#### **CAUTION**

Belt guard must be in place at all times when engine is running.

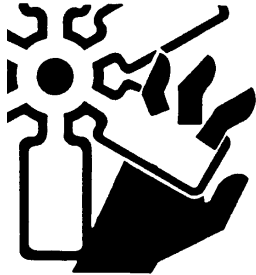

NOTE: While belt is removed, inspect pulleys and bearings. Rotate and feel for hard turning or any unusual sounds. If pulleys or bearings need replacement, see your Northern Lights dealer.

1. Remove cap screws (A) and carefully remove belt guard from engine.
2. Release tension on belt using a breaker bar and socket on tension arm and remove poly-vee belt from pulleys.
3. Inspect belts for cracks, fraying, or stretched out areas. Replace if necessary.
4. Install new belt, making sure belt is correctly seated in all pulley grooves. Refer to belt routing at right.
5. Apply tension to belt with tensioner. Remove socket.
6. Start engine and check belt alignment.

IMPORTANT: Four-valve cylinder head engines are

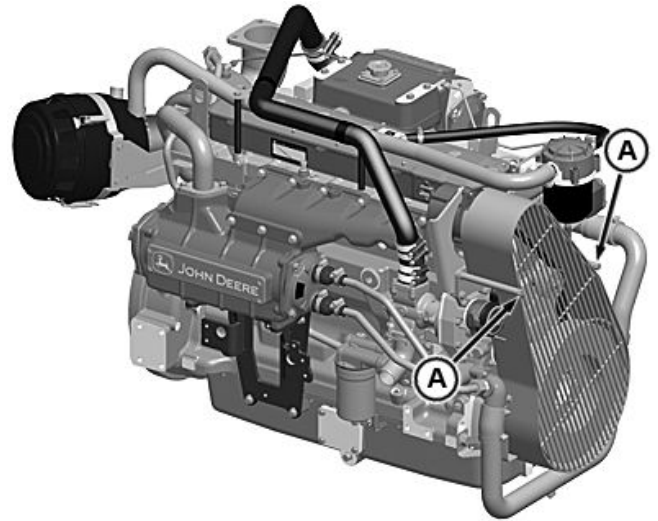

Removal of belt guard. Cap screws (A)

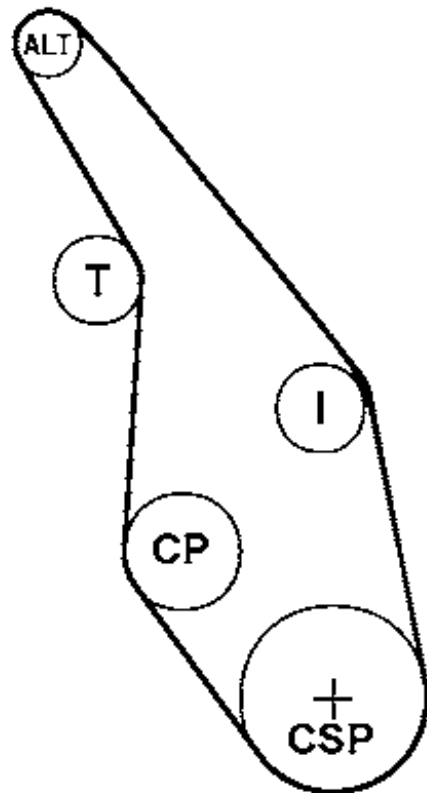

*Belt routing:*

*ALT - Alternator*

*T - Tensioner*

*I - Idler Pulley*

*CP - Coolant Pump*

*CSP - Crankshaft Pulley*

## Service and Maintenance - As Required

### SP 32. Bleeding Fuel System

#### **CAUTION**

High-pressure fluid remaining in fuel lines can cause serious injury. Do not disconnect or attempt repair of fuel lines, sensors, or any other components between the high pressure fuel pump and nozzles on engines with High Pressure Common Rail (HPCR) fuel system. Only technicians familiar with this type of system can perform repairs. (See your Northern Lights dealer.)

Escaping fluid under pressure can penetrate the skin causing serious injury. Avoid hazards by relieving pressure before connecting hydraulic or other lines.

Tighten all connections before applying pressure. Search for leaks with a piece of cardboard. Protect hands and body from high pressure fluids.

If an accident occurs, see a doctor immediately. Any fluid injected into the skin must be surgically removed within a few hours or gangrene may result.

**IMPORTANT:** Four-valve cylinder head engines are especially sensitive to fuel contamination. Do not crack any fuel lines to bleed the fuel system.

**NOTE:** Normally the fuel system on these engines is self-priming and self-bleeding, and does not require a bleeding procedure by the operator.

If engine will not start after filter changes, turn ignition key ON for 60 seconds to prime the fuel system. It may be necessary to turn the key off and on again to re-prime the system.



*Caution: Do not puncture high pressure fuel lines*

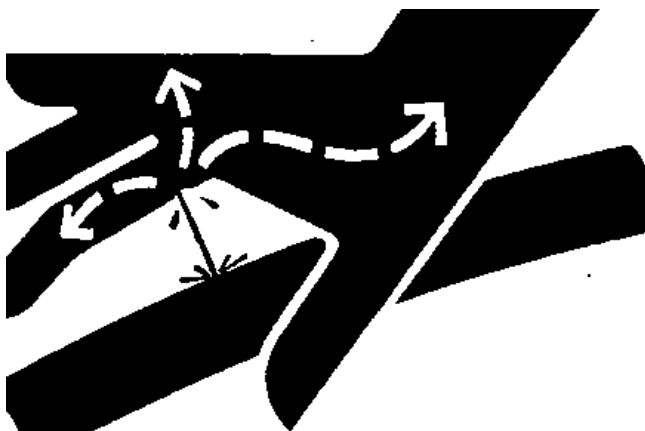

*Caution: Protect hands and body from high pressure fluids*

## Electronically Controlled Engine Layout

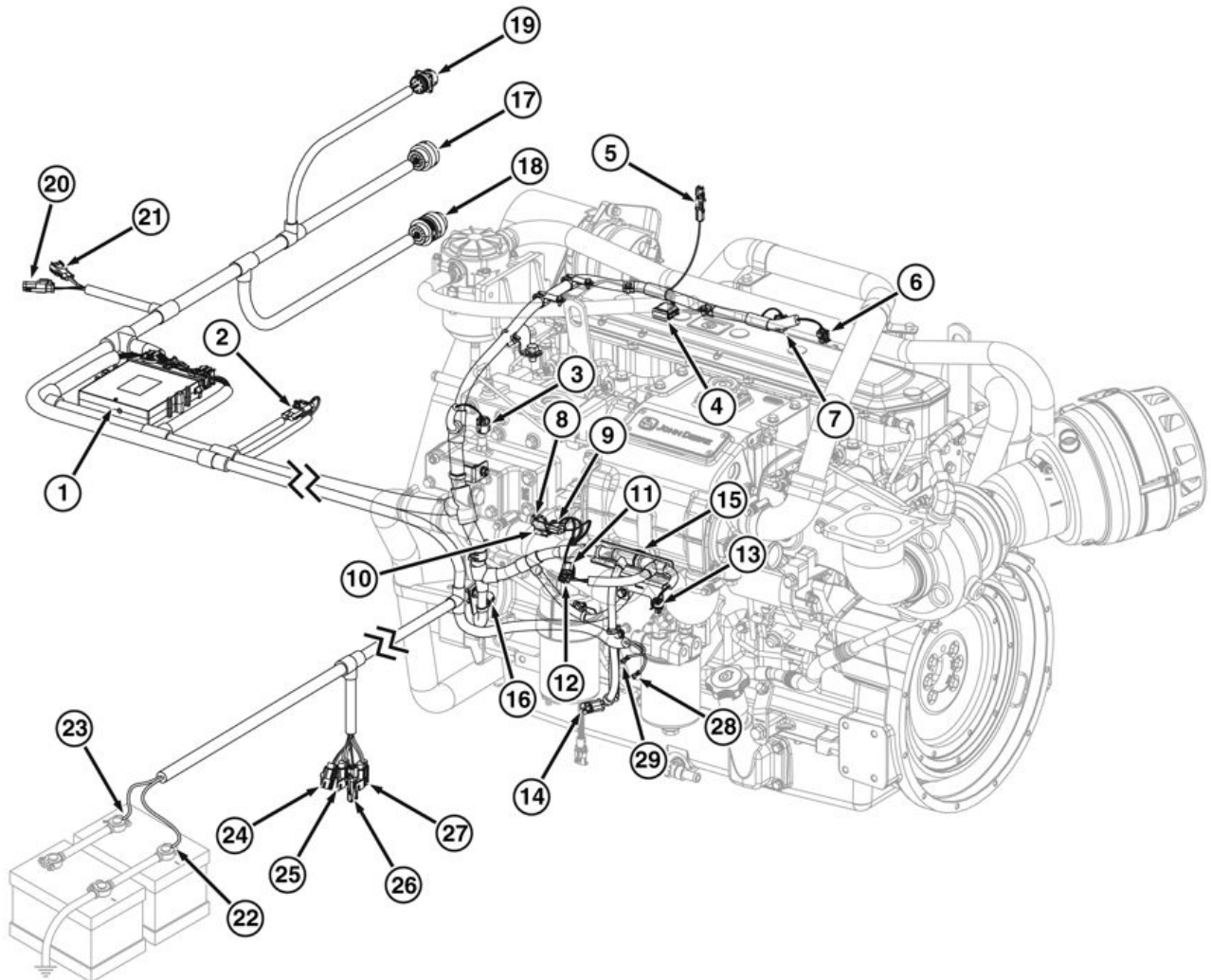

1— Engine Control Unit (ECU)  
 2— Auxiliary Power Connector  
 3— Coolant Temperature Sensor Connector  
 4— Fuel Injection Harness Connector  
 5— Alternator Connector  
 6— Manifold Air Pressure Sensor Connector  
 7— Manifold Air Temperature Sensor Connector  
 8— Suction Control Valve Sensor Connector  
 9— Fuel Temperature Sensor Connector  
 10— Camshaft Position Sensor Connector

11— Low-Pressure Fuel Pump Connector  
 12— Oil Pressure Sensor Connector  
 13— Fuel Pressure Sensor Connector  
 14— Water-in-Fuel Sensor Connector  
 15— Fuel Rail Pressure Sensor Connector  
 16— Crankshaft Position Sensor Connector  
 17— Control Panel Connector  
 18— Auxiliary Connector  
 19— Diagnostic Connector  
 20— CAN Terminator Connector  
 21— Remote On/Off Connector

22— Underterminated Ground (Battery)  
 23— Underterminated Power (Battery)  
 24— Low-Pressure Fuel Pump Fuse (15 Amp)  
 25— ECU Fuse (20 Amp)  
 26— Transient Voltage Protection Connector  
 27— System Fuse (30 Amp)  
 28— Starter Relay Coil Connector (Power)  
 29— Starter Relay Coil Connector (Ground)

---

## Long Term Storage

---

### Engine Storage Guidelines

1. Northern Lights generator sets can be stored outside for up to three (3) months with no long term preparation **IF COVERED BY WATERPROOF COVERING**. Outside storage is **NOT** recommended without a waterproof covering.
2. Northern Lights generator sets can be stored in a standard overseas shipping container for up to three (3) months with no long term preparation.
3. Northern Lights generator sets can be stored inside for up to six (6) months with no long term preparation.
4. Northern Lights generator sets expected to be stored more than six (6) months **MUST** have long term storage preparation. ( See **PREPARING ENGINE FOR LONG TERM STORAGE**, below.)
5. Long term storage includes the use of a stabilized rust preventive oil to protect internal metal components of the engine. This oil should be an SAE 10 oil with 1-4 percent morpholine or equivalent vapor corrosion inhibitor. These rust preventive oils are available from area distributors.

**IMPORTANT: DO NOT USE BIODIESEL DURING MACHINE STORAGE.** When using biodiesel blends, switch to petroleum diesel for long term storage. Before storage, operate engine on at least one complete tank of petroleum diesel fuel to purge the fuel system. Follow normal storage procedures once the fuel system has been purged.

### Preparing Engine for Long Term Storage

The following storage preparations are used for long term engine storage up to one year. After that, the engine should be started, warmed up, and retreated for an extended storage period.

**IMPORTANT:** Any time your engine will not be used for over six (6) months, the following recommendations for storing it and removing it from storage will help to minimize corrosion and deterioration.

1. Change engine oil and replace filter. (See **CHANGE ENGINE OIL AND FILTER** page 31.) Used oil will not give adequate protection. Add one (1) ounce of rust preventive oil to the engine crankcase for every quart of oil. This rust preventive oil should be an SAE 10 oil with 1-4 percent morpholine or equivalent vapor corrosion inhibitor.

2. Ensure the machine fuel tank is filled with high quality petroleum diesel fuel. Filling the tank completely will ensure that water does not build up due to condensation. For storage of more than one year, use Northern Lights **PREMIUM DIESEL FUEL CONDITIONER** (or equivalent) at the specified concentration.
  3. Service air cleaner. (See **REPLACING AIR CLEANER FILTER ELEMENTS**, pages 57-60.)
  4. Draining and flushing of cooling system is not necessary if engine is to be stored only for several months. However, for extended storage periods of a year or longer, it is recommended that the cooling system be drained, flushed, and refilled. Refill with appropriate coolant. (See **RECOMMENDED ENGINE COOLANT** pages 25-26 and **ADDING COOLANT**, page 57.)
  5. Prepare a tank with a solution of diesel fuel and rust preventive oil, at ten (10) ounces of rust preventive oil per gallon of diesel fuel.
  6. Remove existing lines/plugs as required, and run a temporary line from the tank to the engine fuel intake, and another temporary line from the fuel return manifold to the tank, so rust preventive oil solution is circulated through the injection system during cranking.
  7. Crank the engine several revolutions with starter (do not allow the engine to start). This will allow rust preventive oil solution to circulate.
  8. Remove temporary lines installed in Step 6 above, and replace any lines/plugs previously removed.
- NOTE:** One gallon of fuel/oil solution can be used to treat 100 engines; two gallons to treat 200 engines, etc. The oil could then be replenished by adding an additional five (5) ounces of rust preventive oil per gallon of solution. However, starting over with a new solution is recommended to dispose of any water or other impurities.
9. Loosen, or remove and store, fan/alternator poly-vee belt.
  10. Remove and clean batteries. Store them in a cool, dry place and keep them fully charged.
  11. Disengage the clutch for any driveline.

---

## Long Term Storage

---

12. Clean the exterior of the engine with salt-free water and touch up any scratched or chipped painted surfaces with a good quality paint or corrosion inhibitor if not feasible to paint.

13. Coat all exposed (machined) metal surfaces with grease

14. Seal all openings on engine with plastic bags and tape.

15. Store the engine in a dry protected place. If engine must be stored outside, cover it with a waterproof canvas or other suitable protective

### Removing Engine from Long-Term Storage

Refer to the appropriate section for detailed services listed below or have your authorized servicing dealer or engine distributor perform services that you may not be familiar with.

1. Remove all protective coverings from engine. Unseal all openings in engine and remove covering from electrical systems.

2. Remove the batteries from storage. Install batteries (fully charged) and connect the terminals.

3. Install alternator poly-vee belt if removed. Adjust belt tension. (See CHECKING BELT TENSIONER SPRING TENSION AND BELT WEAR pages 38-39) Install belt guard.

4. Perform all appropriate pre-starting checks. (See DAILY PRESTARTING CHECKS, pages 28-30.)

5. Open sea water valve and prime the sea water system.

6. Open fuel valve, fill fuel filter/water separator with clean fuel and bleed the fuel system. (See BLEEDING THE FUEL SYSTEM, page 63)

IMPORTANT: DO NOT operate starter more than 30 seconds at a time. Wait at least 2 minutes for starter to cool before trying again.

7. Crank engine for 20 seconds with starter (do not allow the engine to start). Wait 2 minutes and crank engine an additional 20 seconds to assure bearing surfaces are adequately lubricated.

8. Start engine and run at low idle and no load for several minutes. Warm up carefully and check all gauges before placing engine under load.

9. On the first day of operation after storage, check overall engine for leaks and check all gauges for correct operation.

NOTE: If using BIODIESEL blends after long term storage, frequency of fuel filter plugging may increase initially.



## Troubleshooting

NOTE: If using biodiesel blends above B20, the possibility of some of the symptoms listed below, such as power loss, could increase.

NOTE: Before troubleshooting the engine, first retrieve any fault codes on the diagnostic gauge display and perform the corrective actions. (See information later in this section). If any problems remain, use the following charts to solve engine problems.

### ENGINE

PROBLEM	POSSIBLE CAUSE	RECOMMENDATION(S)
<b>Engine Cranks But Will Not Start</b>	Incorrect starting procedure	Verify correct starting procedure
	No fuel	Check fuel in tank and manual shut-off valve
	Exhaust restricted	Check and correct exhaust restriction
	Fuel filter plugged or filled with water	Replace fuel filter or drain water from filter
	Injection pump not getting fuel or air in fuel system	Check fuel flow at supply pump or bleed fuel system
	Faulty injection pump or nozzles	Consult Authorized Dealer for repair or replacement
<b>Engine Hard to Start or Will Not Start</b>	Engine starting under load	Disengage PTO (if equipped)
	Improper starting procedure	Review starting procedure
	No fuel	Check fuel tank
	Air in fuel line	Bleed fuel line
	Cold weather	Use cold weather starting aids
	Slow starter speed	See “Starter Cranks Slowly”
	Crankcase oil too heavy	Use oil of proper viscosity
	Improper type of fuel	Consult fuel supplier; use proper type of fuel for operating conditions
	Water, dirt, or air in fuel system	Drain, flush, fill, and bleed system
	Clogged fuel filter	Replace filter element
	Dirty or faulty injection nozzles	Consult Authorized Dealer
	Electronic fuel system problem	Consult Authorized Dealer
	Injection pump shut-off not reset	Turn key switch to “OFF” then to “ON”
		Add oil to engine crankcase

## Troubleshooting

<b>ENGINE PROBLEM</b>	<b>POSSIBLE CAUSE</b>	<b>RECOMMENDATION(S)</b>
<b>Engine Knocks</b>	Low engine oil level	Add oil to engine crankcase
	Injection pump out of time	Consult Authorized Dealer
	Low coolant temperature	Remove and check thermostat
	Engine overheating	See "Engine Overheats"
<b>Engine Runs Irregularly or Stalls Frequently</b>	Low coolant temperature	Remove and check thermostat
	Clogged fuel filter	Replace fuel filter elements
	Water, dirt, or air in fuel system	Drain, flush, fill and bleed system
	Poor quality fuel	Change to better quality fuel
	Dirty or faulty injection nozzles	Consult Authorized Dealer
	Electronic fuel system problem	Consult Authorized Dealer
<b>Below Normal Engine Temperature</b>	Defective thermostat	Remove and check thermostat
	Defective temperature gauge or sender	Check gauge, sender and connections
<b>Lack of Power</b>	Engine overloaded	Reduce load
	Intake air restriction	Service air cleaner
	Clogged fuel filter	Replace filter elements
	Improper type of fuel	Use proper fuel
	Overheated engine	See "Engine Overheats"
	Below normal engine temperature	Remove and check thermostat
	Improper valve clearance	Consult Authorized Dealer
	Dirty or faulty injection nozzles	Consult Authorized Dealer
	Injector tip deposits	Use Northern Lights approved biodiesel fuel conditioners containing deposits
	Injection pump out of time	Consult Authorized Dealer
	Turbocharger not functioning (Turbocharged engines only)	Consult Authorized Dealer

## Troubleshooting

<b>ENGINE PROBLEM</b>	<b>POSSIBLE CAUSE</b>	<b>RECOMMENDATION(S)</b>
<b>Lack of Power (cont.)</b>	Leaking exhaust manifold gasket	Consult Authorized Dealer
	Defective aneroid control line	Consult Authorized Dealer
	Restricted fuel hose	Clean or replace fuel hose
	Low fast idle speed	Consult Authorized Dealer
	Damaged propeller	Have propeller checked
	Marine growth	Clean hull
<b>Low Oil Pressure</b>	Low oil level	Add oil
	Improper type of oil	Drain, fill crankcase with oil of proper viscosity and quality
<b>High Oil Consumption</b>	Crankcase oil too late	Use proper viscosity oil
	Oil leaks	Check for leaks in lines, gaskets, and drain plug
	Restricted crankcase vent tube	Clean vent tube
	Defective turbocharger (if equipped)	Consult Authorized Dealer
<b>Engine Emits White Smoke</b>	Improper type of fuel	Use proper fuel
	Low engine temperature	Warm up engine to normal operating temperature
	Defective thermostat	Remove and check thermostat
	Defective injection nozzles	Consult Authorized Dealer
	Engine out of time	Consult Authorized Dealer
<b>Engine Emits Black or Gray Exhaust Smoke</b>	Improper type of fuel	Use proper fuel
	Clogged or dirty air cleaner	Service air cleaner
	Engine overloaded	Reduce load
	Fuel injectors dirty	Use Northern Lights approved biodiesel or diesel fuel conditioners containing detergents. If no improvement is seen, consult authorized dealer.

## Troubleshooting

<b>ENGINE PROBLEM</b>	<b>POSSIBLE CAUSE</b>	<b>RECOMMENDATION(S)</b>
<b>Engine Emits Black or Gray Exhaust Smoke (cont.)</b>	Engine out of time	Consult Authorized Dealer
	Turbocharger not functioning	Consult Authorized Dealer
	Electronic fuel system problem	Consult Authorized Dealer
<b>Engine Overheats</b>	Engine overloaded	Reduce load
	Low coolant level	Fill coolant tank to proper level. Check coolant tank and hoses for loose connections or leaks
	Faulty coolant tank cap	Replace coolant tank cap
	Stretched poly-vee belt or defective tensioner	Check automatic belt tensioner and check belts for stretching. Replace if necessary.
	Faulty sea (raw) water pump	Check/replace impeller/pump
	Low engine oil level	Check oil level. Add oil as required.
	Cooling system needs flushing	Flush cooling system
	Defective thermostat	Remove and check thermostat
	Defective temperature gauge or sender	Check water temperature with thermostat and replace if necessary
	Electronic fuel system problem	Consult Authorized Dealer
	Incorrect grade of fuel	Use correct grade of fuel
	Plugged heat exchanger	Clean heat exchanger and core
	Plugged keel cooler	Flush and clean keel cooler. Check for marine growth on O.D. of keel cooler tubes.
Trash or debris in engine compartment	Clean engine compartment	
<b>High Fuel Consumption</b>	Improper type of fuel	Use proper type of fuel
	Clogged or dirty air cleaner	Service air cleaner
	Engine overloaded	Reduce load
	Improper valve clearance	Consult Authorized Dealer
	Injection nozzles dirty	Consult Authorized Dealer
	Injector tip deposits	Consult Authorized Dealer

## Troubleshooting

### ENGINE

PROBLEM	POSSIBLE CAUSE	RECOMMENDATION(S)
<b>High Fuel Consumption (cont.)</b>	Engine out of time	Consult Authorized Dealer
	Defective turbocharger	Consult Authorized Dealer
	Low engine temperature	Check thermostat

### ELECTRICAL

PROBLEM	POSSIBLE CAUSE	RECOMMENDATION(S)
<b>Undercharged Electrical System</b>	Excessive electrical load from added accessories	Remove accessories or install higher output alternator.
	Excessive engine idling	Increase engine RPM when heavy electrical load is used
	Poor electrical connections on battery, ground strap, starter, or alternator	Inspect and clean as necessary
	Defective battery	Test battery. Replace if necessary.
	Defective alternator	Test charging system. Replace alternator if necessary.
<b>Battery Uses Too Much Water</b>	Cracked battery case	Check for moisture and replace if necessary
	Defective battery	Test battery. Replace if necessary.
	Battery charging rate too high	Test charging system
<b>Batteries Will Not Charge</b>	Loose or corroded connections	Clean and tighten connections
	Sulfated or worn-out batteries	Consult Authorized Dealer
	Stretched poly-vee or defective belt tensioner	Adjust belt tension or replace belt
<b>Starter Will Not Crank</b>	PTO engaged (PTO equipped units only)	Disengage PTO
	Marine gear control engaged	Disengage marine gear
	Loose or corroded connections	Clean and tighten loose connections
	Low battery output voltage	Consult Authorized Dealer
	Faulty start circuit relay	Consult Authorized Dealer
	Blown main system fuse	Replace fuse

---

## Troubleshooting

---

### **ELECTRICAL**

<b>PROBLEM</b>	<b>POSSIBLE CAUSE</b>	<b>RECOMMENDATION(S)</b>
<b>Starter Cranks Slowly</b>	Low battery output	Consult Authorized Dealer
	Crankcase oil too heavy	Use proper viscosity oil
	Loose or corroded connections	Clean and tighten loose connections
<b>Only Starter and Hourmeter Function</b>	Blown fuse on magnetic switch	Replace fuse
<b>Entire Electrical System Does Not Function</b>	Faulty battery connection	Clean and tighten connections
	Sulfated or worn-out batteries	Consult Authorized Dealer
	Blown main system fuse	Replace fuse



## Specifications

General Marine Engine Specifications	M50C13	M65C13	M80C13
<b>ITEM - UNIT OF MEASURE</b>			
<b>General Data</b>			
Engine Type/Cycle	In-line/4	In-line/4	In-line/4
Aspiration	Turbocharged	Turbocharged	Turbocharged
Number of Cylinders	4	4	4
Bore - mm (in.)	106 (4.17)	106 (4.17)	106 (4.17)
Stroke - mm (in.)	127 (5.00)	127 (5.00)	127 (5.00)
Displacement - L (cu in.)	4.5 (275)	4.5 (275)	4.5 (275)
Combustion System	Direct injection	Direct injection	Direct injection
Compression Ratio	16.0:1	16.0:1	16.0:1
<b>Physical Dimensions</b>			
Length - mm (in.)			
Width - mm (in.)			
Height - mm (in.)			
Basic Dry Weight (approx.) - kg (lb)			
<b>Lubrication System (Generator Applications)</b>			
Oil Pressure at Rated rpm ( $\pm 35\%$ ) - kPa (psi)	290 (42)	290 (42)	290 (42)
Oil Fill Capacity - L (qt)	15 (16)	15 (16)	15 (16)
<b>Cooling System (Liquid, pressurized with centrifugal pump)</b>			
Recommended Pressure Cap - kPa (psi)	110 (16)	110 (16)	
Coolant Temperature Operating Range - °C (°F)	82 - 94 (180-202)	82 - 94 (180-202)	82 - 94 (180-202)
Coolant Temperature (Maximum) - °C (°F)	110 (230)	110 (230)	110 (230)
Coolant Capacity - L (qt)	17 (18)	17 (18)	17 (18)
<b>Valve Actuation</b>			
Valve Clearance (Cold)			
Intake - mm (in.)	0.35 (0.014)	0.35 (0.014)	0.35 (0.014)
Exhaust - mm (in.)	0.45 (0.018)	0.45 (0.018)	0.45 (0.018)
<b>Fuel System</b>			
ECU Description	L16	L16	L16
Fuel Injection Type	HPCR	HPCR	HPCR
Governor Type	Electronic	Electronic	Electronic
Primary Fuel Filter	10 micron	10 micron	10 micron
Secondary Fuel Filter	2 micron	2 micron	2 micron
<b>Electrical System</b>			
Battery Capacity (Min.) 12 Volt - CCA	625	625	625
Battery Capacity (Min.) 24 Volt - CCA	500	500	500
<b>Air System</b>			
Maximum Air Intake Restriction - in. H <sub>2</sub> O	25	25	25
kPa (psi)	6.25 (1.0)	6.25 (1.0)	6.25 (1.0)

## Specifications

General Marine Engine Specifications - 4.5L ITEM - UNIT OF MEASURE	M99C13	M120C13	M150C13
<b>General Data</b>			
Engine Type/Cycle	In-line/4	In-line/6	In-line/6
Aspiration	Turbocharged	Turbocharged	Turbocharged
Number of Cylinders	4	6	6
Bore - mm (in.)	106 (4.17)	106 (4.17)	106 (4.17)
Stroke - mm (in.)	127 (5.00)	127 (5.00)	127 (5.00)
Displacement - L (cu in.)	4.5 (275)	4.5 (275)	4.5 (275)
Combustion System	Direct injection	Direct injection	Direct injection
Compression Ratio	16.0:1	16.7:1	16.7:1
<b>Physical Dimensions</b>			
Length - mm (in.)			
Width - mm (in.)			
Height - mm (in.)			
Basic Dry Weight (approx.) - kg (lb)			
<b>Lubrication System (Generator Applications)</b>			
Oil Pressure at Rated rpm ( $\pm 35\%$ ) - kPa (psi)	290 (42)	378 (55)	378 (55)
Oil Fill Capacity - L (qt)	15 (16)	18 (19)	18 (19)
<b>Cooling System (Liquid, pressurized with centrifugal pump)</b>			
Recommended Pressure Cap - kPa (psi)	110 (16)	110 (16)	110 (16)
Coolant Temperature Operating Range - °C (°F)	82 - 94 (180-202)	82 - 94 (180-202)	82-94 (180-202)
Coolant Temperature (Maximum) - °C (°F)	110 (230)	110 (230)	110 (230)
Coolant Capacity - L (qt)	17 (18)	17 (18)	17 (18)
<b>Valve Actuation</b>			
Valve Clearance (Cold)			
Intake - mm (in.)	0.35 (0.014)	0.35 (0.014)	0.35 (0.14)
Exhaust - mm (in.)	0.45 (0.018)	0.45 (0.018)	0.45 (0.018)
<b>Fuel System</b>			
ECU Description	L16	L16	L16
Fuel Injection Type	HPCR	HPCR	HPCR
Governor Type	Electronic	Electronic	Electronic
Primary Fuel Filter	10 micron	10 micron	10 micron
Secondary Fuel Filter	2 micron	2 micron	2 micron
<b>Electrical System</b>			
Battery Capacity (Min.) 12 Volt - CCA	625	925	925
Battery Capacity (Min.) 24 Volt - CCA	500	625	625
<b>Air System</b>			
Maximum Air Intake Restriction - in. H <sub>2</sub> O	25	25	25
kPa (psi)	6.25 (1.0)	6.25 (1.0)	6.25 (1.0)





# DC Wiring Diagram

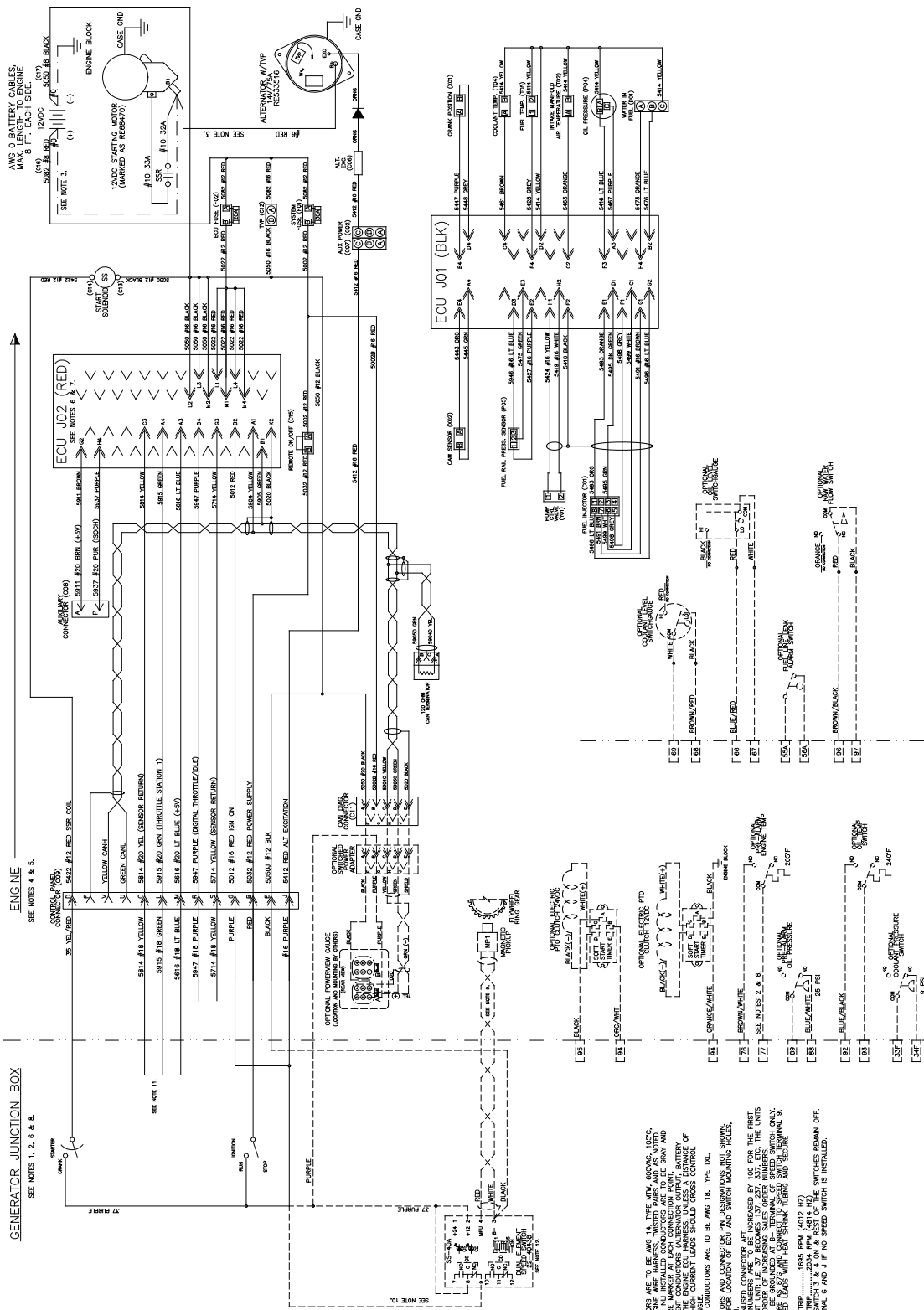

DC Wiring Diagram  
Run/Start Switches -  
M50C13, M55C13, M65C13  
D-4666  
Drawings subject to change without notice.

- NOTES:**
1. ALL INSTALLATION CONDUCTORS ARE TO BE AWG 14, TYPE MW, 600VAC, 105°C, UNLESS COLOR CODED. ALL INSTALLED CONDUCTORS ARE TO BE GRAY AND UNLESS OTHERWISE SPECIFIED, ALL CONDUCTORS ARE TO BE 10 FT. LONG.
  2. UNLESS OTHERWISE SPECIFIED, ALL CONDUCTORS ARE TO BE GRAY AND UNLESS OTHERWISE SPECIFIED, ALL CONDUCTORS ARE TO BE 10 FT. LONG.
  3. WIND ROUTING HIGH CURRENT CONDUCTORS (ALTERNATOR OUTPUT, BATTERY CHARGE, AND FUEL PUMP) TO BE MAINTAINED. THIS CONDUCTOR LAYOUT IS SUBJECT TO CHANGE WITHOUT NOTICE.
  4. WIRING AT A 90 DEGREE ANGLE.
  5. WIRING AT A 90 DEGREE ANGLE.
  6. SEE ALL DRAWINGS C-4670 FOR LOCATION OF RED AND SWITCH MOUNTING HOLES.
  7. MOUNT ECU WITH EMPTY/WIRING CONNECTOR AT HANGERS P1, 130 FOR THE FIRST UNIT AND EACH SUBSEQUENT UNIT, I.E., 237, 337, ETC. THE UNITS MUST BE MOUNTED WITH THE WIRING CONNECTOR AT THE TOP.
  8. WIRING AT A 90 DEGREE ANGLE.
  9. WIRING AT A 90 DEGREE ANGLE.
  10. WIRING AT A 90 DEGREE ANGLE.
  11. INDIVIDUALLY ISOLATE WIRING FROM EACH WIRING TERMINAL AND SECURE.
  12. 2500 RPM SWITCH (M50C13).....1800 RPM (M512 HZ)
  13. 2500 RPM SWITCH (M55C13).....2034 RPM (M512 HZ)
  14. 2500 RPM SWITCH (M65C13).....2034 RPM (M512 HZ)
  15. 2500 RPM SWITCH (M65C13).....2034 RPM (M512 HZ)
  16. 2500 RPM SWITCH (M65C13).....2034 RPM (M512 HZ)
  17. 2500 RPM SWITCH (M65C13).....2034 RPM (M512 HZ)
  18. 2500 RPM SWITCH (M65C13).....2034 RPM (M512 HZ)
  19. 2500 RPM SWITCH (M65C13).....2034 RPM (M512 HZ)
  20. 2500 RPM SWITCH (M65C13).....2034 RPM (M512 HZ)
  21. 2500 RPM SWITCH (M65C13).....2034 RPM (M512 HZ)
  22. 2500 RPM SWITCH (M65C13).....2034 RPM (M512 HZ)
  23. 2500 RPM SWITCH (M65C13).....2034 RPM (M512 HZ)
  24. 2500 RPM SWITCH (M65C13).....2034 RPM (M512 HZ)
  25. 2500 RPM SWITCH (M65C13).....2034 RPM (M512 HZ)
  26. 2500 RPM SWITCH (M65C13).....2034 RPM (M512 HZ)
  27. 2500 RPM SWITCH (M65C13).....2034 RPM (M512 HZ)
  28. 2500 RPM SWITCH (M65C13).....2034 RPM (M512 HZ)
  29. 2500 RPM SWITCH (M65C13).....2034 RPM (M512 HZ)
  30. 2500 RPM SWITCH (M65C13).....2034 RPM (M512 HZ)
  31. 2500 RPM SWITCH (M65C13).....2034 RPM (M512 HZ)
  32. 2500 RPM SWITCH (M65C13).....2034 RPM (M512 HZ)
  33. 2500 RPM SWITCH (M65C13).....2034 RPM (M512 HZ)
  34. 2500 RPM SWITCH (M65C13).....2034 RPM (M512 HZ)
  35. 2500 RPM SWITCH (M65C13).....2034 RPM (M512 HZ)
  36. 2500 RPM SWITCH (M65C13).....2034 RPM (M512 HZ)
  37. 2500 RPM SWITCH (M65C13).....2034 RPM (M512 HZ)
  38. 2500 RPM SWITCH (M65C13).....2034 RPM (M512 HZ)
  39. 2500 RPM SWITCH (M65C13).....2034 RPM (M512 HZ)
  40. 2500 RPM SWITCH (M65C13).....2034 RPM (M512 HZ)
  41. 2500 RPM SWITCH (M65C13).....2034 RPM (M512 HZ)
  42. 2500 RPM SWITCH (M65C13).....2034 RPM (M512 HZ)
  43. 2500 RPM SWITCH (M65C13).....2034 RPM (M512 HZ)
  44. 2500 RPM SWITCH (M65C13).....2034 RPM (M512 HZ)
  45. 2500 RPM SWITCH (M65C13).....2034 RPM (M512 HZ)
  46. 2500 RPM SWITCH (M65C13).....2034 RPM (M512 HZ)
  47. 2500 RPM SWITCH (M65C13).....2034 RPM (M512 HZ)
  48. 2500 RPM SWITCH (M65C13).....2034 RPM (M512 HZ)
  49. 2500 RPM SWITCH (M65C13).....2034 RPM (M512 HZ)
  50. 2500 RPM SWITCH (M65C13).....2034 RPM (M512 HZ)
  51. 2500 RPM SWITCH (M65C13).....2034 RPM (M512 HZ)
  52. 2500 RPM SWITCH (M65C13).....2034 RPM (M512 HZ)
  53. 2500 RPM SWITCH (M65C13).....2034 RPM (M512 HZ)
  54. 2500 RPM SWITCH (M65C13).....2034 RPM (M512 HZ)
  55. 2500 RPM SWITCH (M65C13).....2034 RPM (M512 HZ)
  56. 2500 RPM SWITCH (M65C13).....2034 RPM (M512 HZ)
  57. 2500 RPM SWITCH (M65C13).....2034 RPM (M512 HZ)
  58. 2500 RPM SWITCH (M65C13).....2034 RPM (M512 HZ)
  59. 2500 RPM SWITCH (M65C13).....2034 RPM (M512 HZ)
  60. 2500 RPM SWITCH (M65C13).....2034 RPM (M512 HZ)
  61. 2500 RPM SWITCH (M65C13).....2034 RPM (M512 HZ)
  62. 2500 RPM SWITCH (M65C13).....2034 RPM (M512 HZ)
  63. 2500 RPM SWITCH (M65C13).....2034 RPM (M512 HZ)
  64. 2500 RPM SWITCH (M65C13).....2034 RPM (M512 HZ)
  65. 2500 RPM SWITCH (M65C13).....2034 RPM (M512 HZ)
  66. 2500 RPM SWITCH (M65C13).....2034 RPM (M512 HZ)
  67. 2500 RPM SWITCH (M65C13).....2034 RPM (M512 HZ)
  68. 2500 RPM SWITCH (M65C13).....2034 RPM (M512 HZ)
  69. 2500 RPM SWITCH (M65C13).....2034 RPM (M512 HZ)
  70. 2500 RPM SWITCH (M65C13).....2034 RPM (M512 HZ)
  71. 2500 RPM SWITCH (M65C13).....2034 RPM (M512 HZ)
  72. 2500 RPM SWITCH (M65C13).....2034 RPM (M512 HZ)
  73. 2500 RPM SWITCH (M65C13).....2034 RPM (M512 HZ)
  74. 2500 RPM SWITCH (M65C13).....2034 RPM (M512 HZ)
  75. 2500 RPM SWITCH (M65C13).....2034 RPM (M512 HZ)
  76. 2500 RPM SWITCH (M65C13).....2034 RPM (M512 HZ)
  77. 2500 RPM SWITCH (M65C13).....2034 RPM (M512 HZ)
  78. 2500 RPM SWITCH (M65C13).....2034 RPM (M512 HZ)
  79. 2500 RPM SWITCH (M65C13).....2034 RPM (M512 HZ)
  80. 2500 RPM SWITCH (M65C13).....2034 RPM (M512 HZ)
  81. 2500 RPM SWITCH (M65C13).....2034 RPM (M512 HZ)
  82. 2500 RPM SWITCH (M65C13).....2034 RPM (M512 HZ)
  83. 2500 RPM SWITCH (M65C13).....2034 RPM (M512 HZ)
  84. 2500 RPM SWITCH (M65C13).....2034 RPM (M512 HZ)
  85. 2500 RPM SWITCH (M65C13).....2034 RPM (M512 HZ)
  86. 2500 RPM SWITCH (M65C13).....2034 RPM (M512 HZ)
  87. 2500 RPM SWITCH (M65C13).....2034 RPM (M512 HZ)
  88. 2500 RPM SWITCH (M65C13).....2034 RPM (M512 HZ)
  89. 2500 RPM SWITCH (M65C13).....2034 RPM (M512 HZ)
  90. 2500 RPM SWITCH (M65C13).....2034 RPM (M512 HZ)
  91. 2500 RPM SWITCH (M65C13).....2034 RPM (M512 HZ)
  92. 2500 RPM SWITCH (M65C13).....2034 RPM (M512 HZ)
  93. 2500 RPM SWITCH (M65C13).....2034 RPM (M512 HZ)
  94. 2500 RPM SWITCH (M65C13).....2034 RPM (M512 HZ)
  95. 2500 RPM SWITCH (M65C13).....2034 RPM (M512 HZ)
  96. 2500 RPM SWITCH (M65C13).....2034 RPM (M512 HZ)
  97. 2500 RPM SWITCH (M65C13).....2034 RPM (M512 HZ)
  98. 2500 RPM SWITCH (M65C13).....2034 RPM (M512 HZ)
  99. 2500 RPM SWITCH (M65C13).....2034 RPM (M512 HZ)
  100. 2500 RPM SWITCH (M65C13).....2034 RPM (M512 HZ)















4420 14th Ave. NW., Seattle WA 98107

Tel: (206) 789-3880 • 1-800-762-0165 • [www.northern-lights.com](http://www.northern-lights.com)

Northern Lights and Lugger are registered trademarks of Northern Lights, Inc.

© 2021 All rights reserved. Litho USA.