



* Assembly Guide & Warranty Card Included

TR950 TREADMILL OWNER'S MANUAL



IMPORTANT:

All products shown are prototype. Actual product delivered may vary.
Product specifications, features & software are subject to change without notice.
For the most up-to-date owner's manual please visit www.truefitness.com.
For documents in additional languages please visit www.truefitness.com/resources/document-library/

IMPORTANTE:

Todos los productos mostrados son prototipos. La realidad el producto suministrado puede diferir.
Especificaciones de productos, características y software están sujetas a cambios sin previo aviso.
Para la más actualizada de este manual del propietario, por favor visite www.truefitness.com
Para los documentos en otros idiomas, por favor visite www.truefitness.com/resources/document-library/

IMPORTANT: Tous les produits présentés sont prototype. Le produit réel livré peut varier. Spécifications du produit, caractéristiques et logiciels sont sujettes à modification sans préavis. Pour la plus à jour le manuel du propriétaire s'il vous plaît visitez www.truefitness.com. Pour documents dans des langues supplémentaires, veuillez www.truefitness.com/resources/document-library/ de visite

重要提示: 显示所有产品的原型。实际交付的产品可能有所不同产品规格,功能和软件如有更改,恕不另行通知迄今为止对于大多数的使用说明书,请访问www.truefitness.com 对于其他语言的文档,请访问www.truefitness.com/resources/document-library/

مهم:
اهمى لست يلعفل اجتنملا فل تخت دق . جذومنلا يه ةضورعمل ا تاجتنملا عىم ج
راعش! نود رى غتلل ةلباق جم اربل او تازىم او ، جتنملا تافص او م
www.truefitness.com ةراىزى جرى لكالما لىلد نألا ىتح لصى ام مظعمل
www.truefitness.com/resources/document-library/ ةراىزى جرى ، ةىفاضل تاغل ي ف تادن تسملل

WICHTIG: Alle hier gezeigten Produkte sind Prototypen. Das tatsächliche Produkt ausgeliefert wird, kann variieren. Produkt-Spezifikationen, Funktionen und Software können sich ohne vorherige Ankündigung ändern. In den meisten Fällen bis zu Bedienungsanleitung Bisher besuchen Sie bitte www.truefitness.com. Für Dokumente in weiteren Sprachen finden Sie unter www.truefitness.com/resources/document-library/

BELANGRIJK: Alle getoonde producten zijn prototype. Daadwerkelijke product geleverd kan verschillen. Product specificaties, eigenschappen & software zijn onderhevig aan verandering zonder kennisgeving. Voor de meest actuele handleiding van de eigenaar kunt u terecht www.truefitness.com. Voor documenten in andere talen kunt u terecht op www.truefitness.com/resources/document-library/

ВАЖНО: Все товары указаны прототипа. Фактический продукт, поставляемый могут отличаться. Технические характеристики, особенности и программного обеспечения могут быть изменены без предварительного уведомления. Для получения самой последней на сегодняшний день руководство по эксплуатации пожалуйста, посетите www.truefitness.com
.Для документов на другие языки, пожалуйста, посетите www.truefitness.com/resources/document-library/

A MESSAGE TO OUR CUSTOMERS

Frank Trulaske began TRUE Fitness® over thirty-five year ago with the simple philosophy of delivering superior fitness products, service, and support. Today, TRUE is the global leader in premium fitness equipment for the commercial and residential markets. Our goal is to be the leader in technology, innovation, performance, safety and style. TRUE has received many awards for its product over the years and remains the benchmark for the industry. Fitness facilities and consumers invest in TRUE products for their durable commercial platforms used in all its products, both commercial and residential alike.

The proud manufacturing tradition of quality and the culture of innovation at TRUE have given rise to a full line of extraordinary cardio and strength equipment. As a result, people all over the world are benefiting from the TRUE experience. Innovation across the full product line has made TRUE successful and is a trademark of the TRUE heritage. TRUE's patented Heart Rate Control technology is just one of the remarkable ways we deliver simple and superior performance every user can enjoy, and most importantly, use to achieve personal health and fitness goals.

At the heart of our success is the relentless and systematic life testing of both our products and their components. We have dedicated employees who understand our philosophy is to deliver the best products in the world.

Our goal is to deliver the world's best premium equipment for our customers' health and fitness solutions.

Table of Contents

Chapter 1: Safety Instructions

Safety Instructions.....	5
Space Requirements.....	8
Grounding Instructions.....	9
Power Requirements.....	10
Warning Decals.....	11
Compliances.....	11

Chapter 2: Assembly Instructions

Pre Assembly Checklist.....	13
Assembly Steps.....	15

Chapter 3: Product Overview

Product Overview.....	30
-----------------------	----

Chapter 4: Care & Maintenance

Care & Maintenance.....	32
Cleaning the Equipment.....	32
Running Belt Alignment.....	33
Tensioning the Running Belt.....	34
Belt Lubrication.....	34
Leveling the Equipment.....	35
Other Scheduled Preventive Maintenance.....	35
Long Term Storage.....	35

Chapter 5: Customer Service

Contacting Service.....	36
Contacting Sales.....	36
Reporting Freight or Parts Damage.....	37

Chapter 6: Additional Information

Wiring Diagram.....	38
Troubleshooting Guide.....	39



Chapter 7: Warranty Information

TR950 Warranty.....	45
---------------------	----





CHAPTER 1: SAFETY INSTRUCTIONS

IMPORTANT SAFETY INSTRUCTIONS SAVE THESE SAFETY INSTRUCTIONS

This equipment is intended for a commercial or institutional setting. This owner's manual should be accessible to all personal trainers, faculty, and members.

-  **WARNING:** ALL EXERCISERS MUST READ ALL INSTRUCTIONS BEFORE USING THE EQUIPMENT.
-  **WARNING:** Heart rate monitoring systems may be inaccurate for some individuals. Over-exercising may result in serious injury or death. If you feel faint, stop exercising immediately.
-  **WARNING:** Equipment should be immediately taken out of use if it fails to work properly or when a warning is presented electronically.

TRUE STRONGLY recommends seeing a physician for a complete medical exam before undertaking an exercise program, particularly if the user has a family history of high blood pressure or heart disease, is over the age of 45, smokes, has high cholesterol, is obese or has not exercised regularly in the past year. Additionally, TRUE recommends consulting a fitness professional on the correct use of this product. If at any time while exercising the user experiences faintness, dizziness, pain or shortness of breath, he or she must stop immediately.

-  **WARNING:** To reduce the risk of electrical shock, always unplug this TRUE product before cleaning or attempting any maintenance activity. Do not handle the plug with wet hands.
-  **WARNING:** To reduce the risk of burns, fire, electric shock, or injury, it is imperative to connect each product to a properly grounded 110V electrical outlet. A risk of electrical shock may result from improper connection of the equipment's grounding conductor. Check with a qualified electrician if you are unsure about proper ground techniques. Do not modify the plug provided with this product. If it will not fit an electrical outlet, have a proper outlet installed by a qualified electrician. Your TRUE Fitness product must be properly grounded to reduce risk of shock if the equipment malfunctions. Your equipment is equipped with an electrical cord, which includes an equipment grounding conductor and a grounding plug. The plug must be inserted into an outlet that has been properly installed and grounded in accordance with all local codes and ordinances. A temporary adapter cannot be used to connect this plug to a two-pole receptacle in North America. If a properly grounded 15 amp outlet is not available, a qualified electrician must install one.
-  **WARNING:** Do not move the equipment by lifting the console. Do not use the console as a handlebar during a workout.
-  **WARNING:** This product contains chemicals known to the state of California to cause cancer and birth defects or other reproductive harm.
-  **WARNING:** Keep equipment stable on flat ground.

CHAPTER 1: SAFETY INSTRUCTIONS

 **WARNING:** Replace warning labels that may be worn, damaged, or missing.

 **WARNING:** Replace any non-working or damaged components, remove the unit from service until repair is performed.

 **WARNING:** To reduce the risk of burns, fire, and electric shock or injury to persons, follow these instructions:

- This appliance should never be left unattended when plugged in.
- Do not use any type of extension cord with this product.
- Unplug it from the outlet when not in use and before any servicing.
- Do not operate the equipment while being covered with a blanket, plastic, or anything that insulates or stops airflow.

 **WARNING:** Risk of personal injury-crushing hazard when equipment is in operation - Keep feet, hands, and fingers away from moving parts.

 **CAUTION:**

- Do not use typing or web surfing features at excessive speeds. Always stabilize yourself by holding a stationary handle when using typing or web surfing features. (Varies by console option)
- Health related injuries may result from incorrect or excessive use of exercise equipment.
- Do not use the contact heart rate grips as a handlebar during a workout.
- Any changes or modifications to this equipment could void the product warranty.
- To disconnect, turn power OFF at the ON/OFF switch if applicable, then remove plug from electrical outlet.
- Never operate a TRUE product if it has a damaged power cord or electrical plug, or if it has been dropped, damaged, or even partially immersed in water. Contact TRUE Customer Service for a replacement.
- Use a TRUE AC power cord or AC/DC adapter only.
- *Note the plug configuration for the power adapter may vary by country.
- Position this product so the power cord plug is accessible to the user.
- Keep the power cord away from heated surfaces. Do not pull the equipment by the power cord or use the cord as a handle. Do not run the power cord along the side or under the treadmill.
- If the electrical supply cord is damaged it must be replaced by the manufacturer, an authorized service agent, or a similarly qualified person to avoid a hazard.
- Do not use this product in areas where aerosol spray products are being used or where oxygen is being administered. Such substances create the danger of combustion and explosion.
- Always follow the console instructions for proper operation.
- Close supervision is necessary when used near children under the age of 15, or disabled persons.
- Do not use this product outdoors, near water, while wet, or in areas of high humidity including extreme temperature changes.
- Never operate a TRUE product with the air openings blocked. Keep air openings free of lint, hair or any obstructing material.
- Never insert objects into any openings in this product. If an object should drop inside, turn off the power, unplug the power cord from the outlet and carefully retrieve it. If the item cannot be reached, contact TRUE Customer Service.
- Never place liquids of any type directly on the unit except in the accessory tray or bottle holders. Containers with lids are recommended.
- Wear shoes with rubber or high traction soles. Do not use shoes with heels, leather soles, cleats or spikes. Make sure no stones are embedded in the soles. Do not use this product in bare feet. Keep all loose clothing, shoelaces and towels away from moving parts.
- Do not reach into or underneath the unit, or tip it on its side during operation.
- Use correct ergonomic positioning while running on treadmill.
- Do not allow animals on or near the equipment while in operation.

CHAPTER 1: SAFETY INSTRUCTIONS

! CAUTION:

- Use the side handrails whenever additional stability is required. In case of emergency, such as tripping, the side handrails should be grabbed and the user should place his/her feet on the side platforms. The front handlebars should be used to grasp the heart rate sensors or to rest the hand on while operating the activity zone keys, but not for stability, emergency, or continuous use.
- Do not exceed TR950 maximum user weight of 350lbs (159 kg).
- Do not use if you have a cold or fever.
- When using this exercise machine, basic precautions should always be followed.
- Use this equipment only for its intended use as described in this manual.
- Do not use attachments not recommended by the manufacturer.
- Allow only trained personnel to service this equipment.
- Avoid the possibility of bystanders being struck or caught between moving parts by making sure that they are out of reach of the equipment while it is in motion.
- This appliance can be used by children aged from 8 years and above and persons with reduced physical, sensory or mental capabilities or lack of experience and knowledge if they have been given supervision or instruction concerning use of the appliance in a safe way and understand the hazards involved.
- Children shall not play with the appliance.
- Cleaning and user maintenance shall not be made by children without supervision.
- Allow only one person at a time on the equipment while it's operating.
- It is the sole responsibility of the owner/operator to ensure regular and scheduled maintenance is performed.
- To avoid injury stand on the side rails before starting the treadmill.
- Avoid exiting treadmill while leaving the tread belt in motion.
- Never walk or jog backwards on the treadmill.
- When mounting the treadmill, ensure the treadmill belt is not running and then proceed with one step at a time to maintain balance using the handrails as needed.
- While the treadmill is in use, proceed at a speed that the user can safely maintain with the ability to immediately engage the safety key to stop the treadmill belt if necessary.

! CAUTION:

- To avoid serious injury, do not touch the incline rack while the treadmill is in use.
- To avoid serious injury, do not touch the belt while the treadmill is in use.

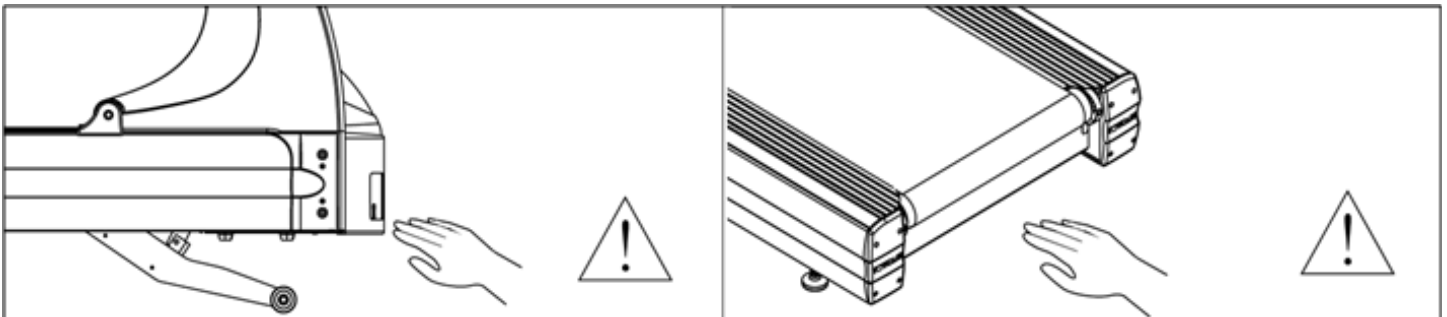

CHAPTER 1: SAFETY INSTRUCTIONS

SPACE REQUIREMENTS:

TRUE's recommendation is to leave a minimum of 24" (0.6m) on each side of the treadmill and a 79" (2 m) safety zone at the rear of the treadmill.

TR950:

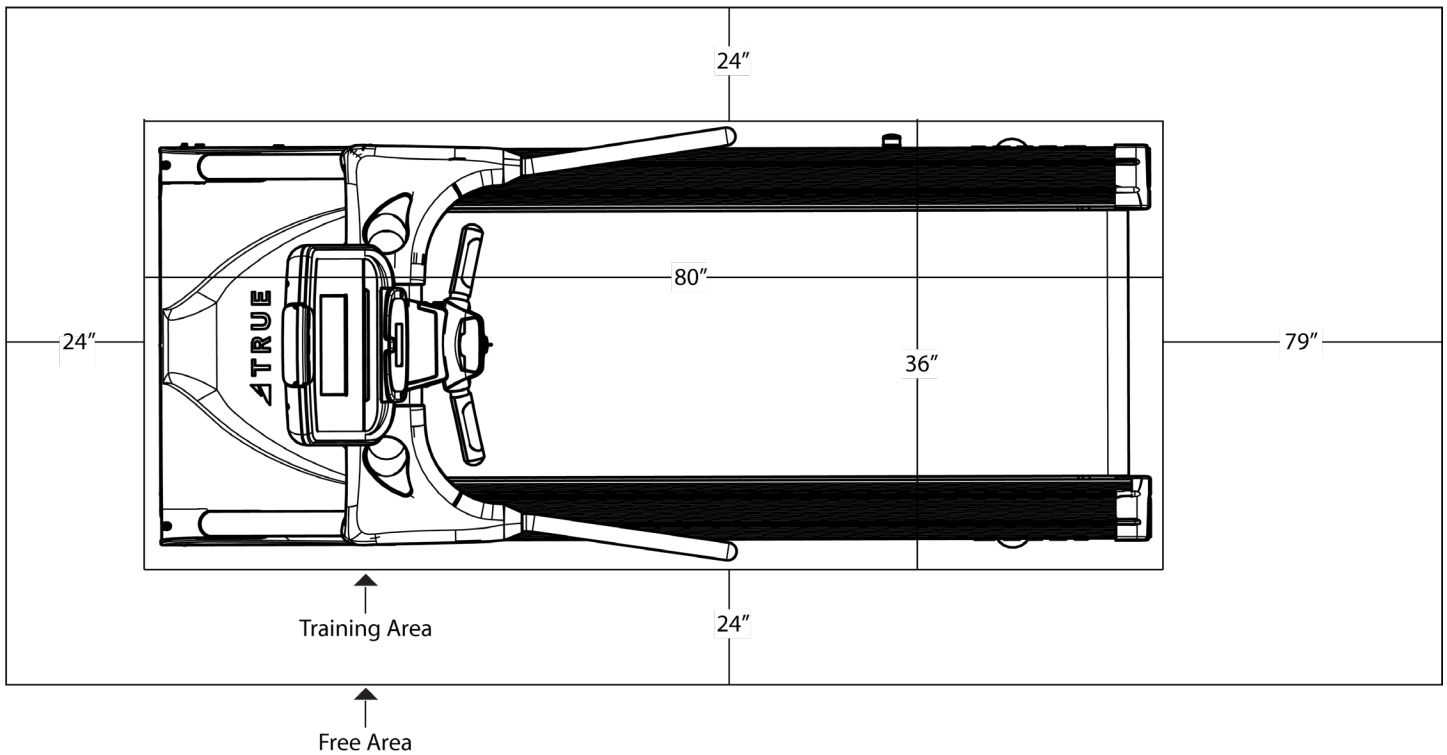

CHAPTER 1: SAFETY INSTRUCTIONS

GROUNDING INSTRUCTIONS:

This product must be grounded, if it should malfunction or breakdown, grounding provides a path of least resistance for electric current to reduce the risk of electric shock. This product is equipped with a cord having an equipment-grounding conductor and a grounding plug. The plug must be plugged into an appropriate outlet that is properly installed and grounded in accordance with all local codes and ordinances.

DANGER:

- Improper connection of the equipment-grounding conductor can result in a risk of electric shock.
- Check with a qualified electrician or serviceman if you are in doubt as to whether the product is properly grounded. Do not modify the plug provided with the product. If it will not fit the outlet, have a proper outlet installed by a qualified electrician.
- Do not remove the motor cover or you may risk injury due to electric shock.
- 120-Volt: This model is for use on a nominal 120-V circuit and has a grounding plug that looks like the plug illustrated in figure A. Make sure the product is connected to an outlet having the same configuration as the plug. No adaptor should be used with this product.
- 230-Volt: This model is for use on a circuit having a nominal rating more than 120-V and is factory-equipped with a specific electric cord and has a grounding plug that looks like the plug illustrated in figure B. Make sure that the product is connected to an outlet having the same configuration as the plug in Figure B. No adapter should be used with this product. If the product must be reconnected for use on a different type of electric circuit, the reconnection should be made by qualified service personnel.

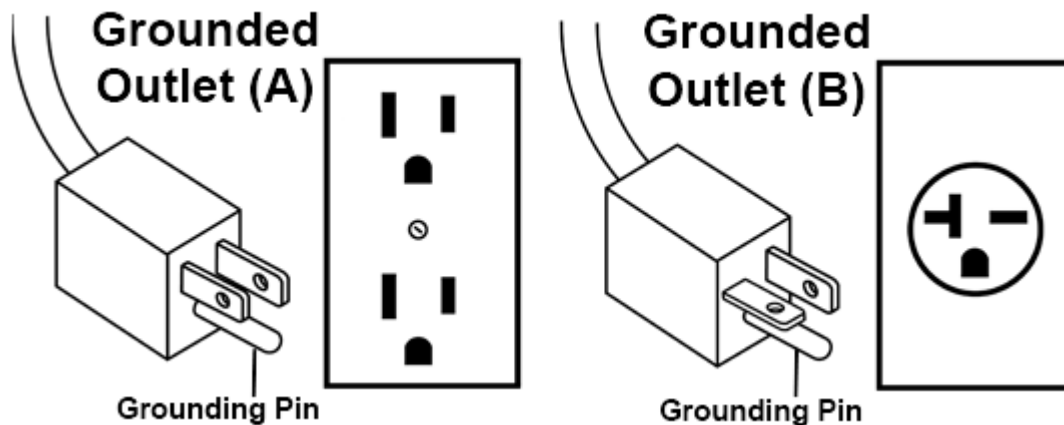

CHAPTER 1: SAFETY INSTRUCTIONS

POWER REQUIREMENTS FOR TRUE PRODUCTS

NOTE: Read and understand all instructions on this sheet and in the Owner's manual before plugging any TRUE power cord into an electrical outlet. This information sheet will help you identify the voltage and cords you need where you live and will outline requirements for:

- Grounded, dedicated lines
- Voltage
- Power cords
- Power adapters
- Extension cords

!DANGER: Improper connection of the equipment-grounding conductor can result in risk of electric shock. Check with a qualified electrician or service provider if you are in doubt as to whether the equipment is properly grounded or installed on a dedicated line. Seek a qualified electrician to perform any modifications to the cord or plug. TRUE is not responsible for injuries or damages as a result of cord or plug modification.

!CAUTION: Place cords away from heat (such as baseboards). Use care to arrange any cord so it doesn't become an obstacle.

Extension Cords

Do not use an extension cord to supply power to any TRUE product.

Grounded, Dedicated Line

TRUE equipment must be grounded. If it should malfunction or break down, grounding provides a path of least resistance for electric current to reduce the risk of electric shock. TRUE cords (except for cycle adapters) have an equipment-grounding conductor and a grounding plug. The plug must be plugged into an appropriate outlet that is properly installed and grounded in accordance with all local codes and ordinances where you live. Do not use a ground plug adapter to adapt the power cord to a non-grounded outlet. Do not use a GFCI outlet or GFCI circuit breaker. A dedicated line will assure that adequate power is available for safe operation over the life of your TRUE Product.

Voltage

Voltage required for your unit is located on the serial number decal (usually on the front of the unit). Depending on where you live voltage requirements differ.

For example, in the United States some TRUE treadmills require a circuit rated 115 VAC, 60 Hz and 20 amps. See Figure 1. However, a home typically has 15 amp outlets. In this case, contact an electrician to install a 20 amp dedicated line prior to use. See Figure 2.

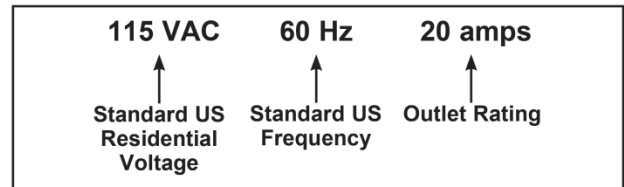

Figure 1

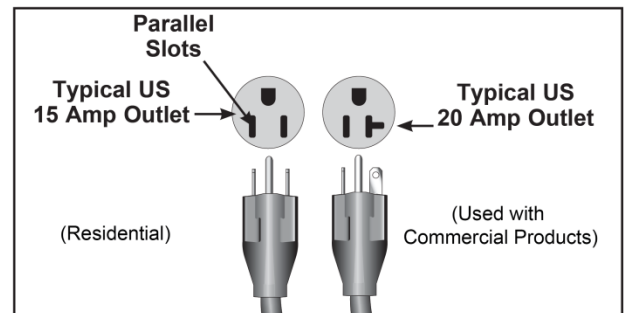

Figure 2

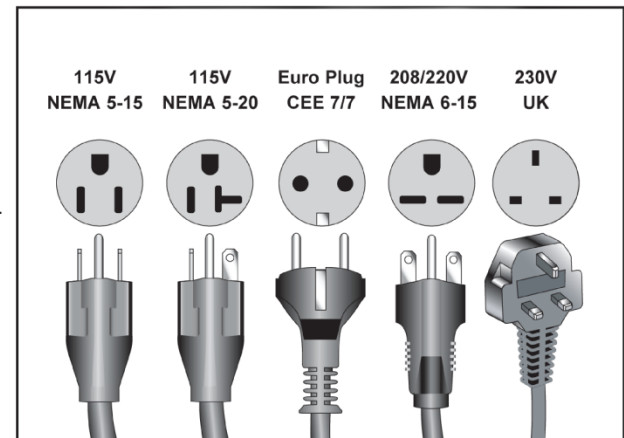



Figure 3

CHAPTER 1: SAFETY INSTRUCTIONS

WARNING DECALS:

 **WARNING:** Replace warning labels that may be worn, damaged, or missing.

To replace any worn or missing decals contact TRUE FITNESS by visiting www.truefitness.com or contact customer service at 800-883-8783.

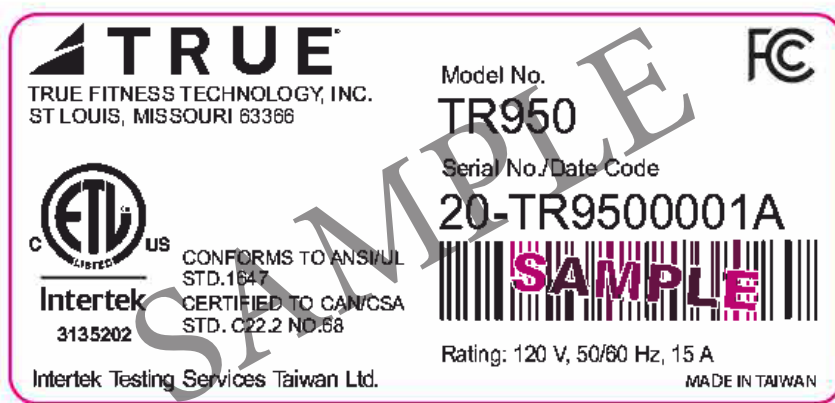
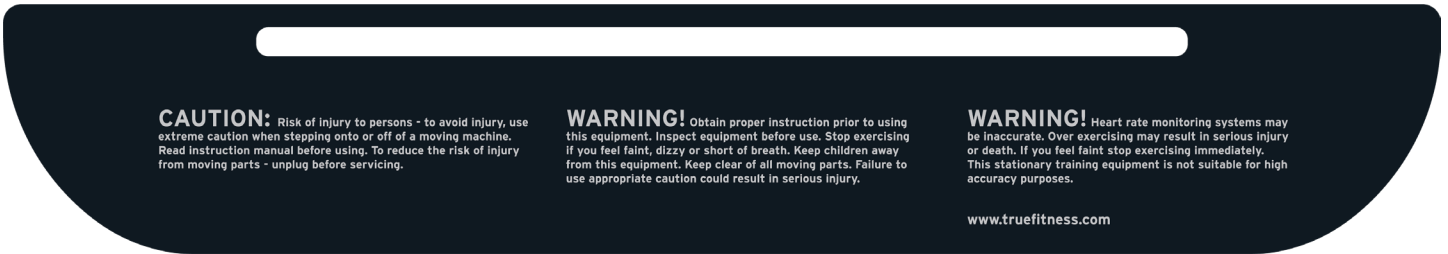

COMPLIANCES:

This equipment complies with all applicable codes and regulations. For a complete list of compliances, please visit www.truefitness.com.

CHAPTER 2: ASSEMBLY GUIDE

IMPORTANT SAFETY INSTRUCTIONS

- **Read and understand all instructions and warnings prior to use.**
- Obtain a medical exam before beginning any exercise program. If at any time during exercise you feel faint, dizzy, or experience pain, stop and consult your physician.
- Obtain proper instruction prior to use.
- This unit is intended for commercial use only.
- Inspect the unit for incorrect, worn, or loose components and do not use until corrected, replaced, or tightened prior to use.
- Do not wear loose or dangling clothing while using the unit.
- Care should be used when mounting or dismounting the unit.
- Read, understand, and test the emergency stop procedures before use.
- Disconnect all power before servicing the unit.
- Do not exceed maximum user weight of 350 lbs.
- Keep the top side of the moving surface clean and dry.
- Keep children and animals away.
- Use caution when moving and assembling unit.
- All exercise equipment is potentially hazardous. If attention is not paid to the conditions of equipment usage, death, or serious injury could occur.
- Save these instructions.

Basic Guidelines for Setting Up the Equipment:

After removing the equipment from the packaging, place the equipment on a clean, level surface. Make sure the electrical cord easily reaches a grounded three-pronged outlet.

Important Electrical Requirements – 120V:

Your TRUE equipment requires a dedicated 120 volt, alternating current (AC), 20 amp grounded outlet circuit. This means nothing else can be plugged into the same circuit. Most power circuits are rated for this 120V AC 20 amp requirement, but you must ensure the equipment does not share the circuit with anything else.

Important Electrical Requirements – 220V:

Your TRUE equipment requires a dedicated 230 volt, alternating current (AC), 15 amp grounded outlet circuit. This means nothing else can be plugged into the same circuit. Most power circuits are rated for this 230V AC 15 amp requirement, but you must ensure the equipment does not share the circuit with anything else.

DANGER: Do not use an extension cord or ungrounded outlet:

The ground helps prevent electrical damage to your equipment and enhances your safety by helping to prevent shock. Check with a qualified electrician or serviceman if you are in doubt as to whether the equipment is properly grounded. Do not modify the plug provided with the unit if it will not fit the outlet. Have a proper outlet installed by a qualified electrician.

CHAPTER 2: ASSEMBLY GUIDE

PRE-ASSEMBLY CHECKLIST:

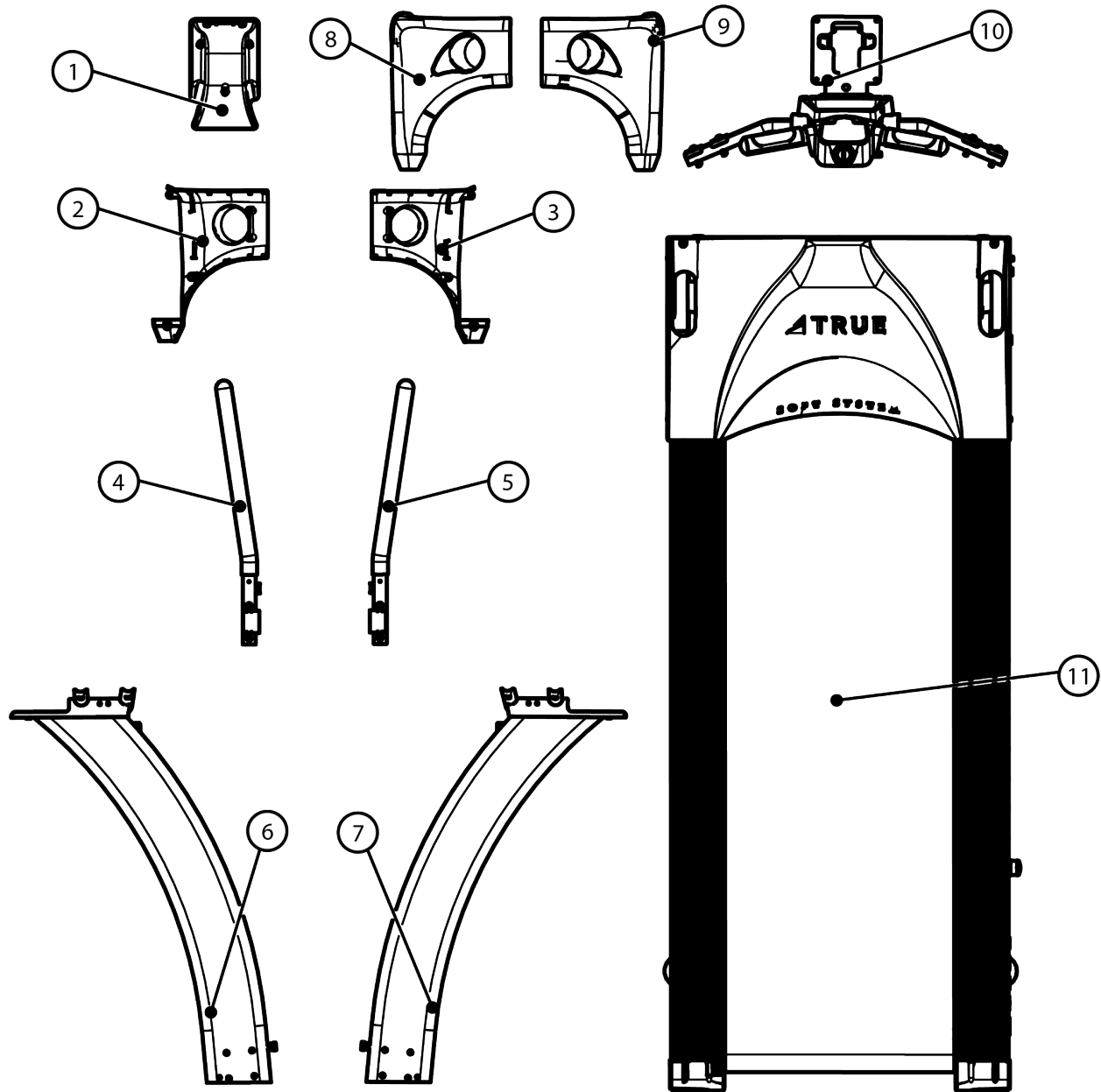

ITEM	DESCRIPTION	Qty.
1	Rear Console Cover Assembly	1
2	Left Shoulder Bottom Assembly	1
3	Right Shoulder Bottom Assembly	1
4	Left Handrail Assembly	1
5	Right Handrail Assembly	1
6	Left Pedestal Upright Assembly	1

ITEM	DESCRIPTION	Qty.
7	Right Pedestal Upright Assembly	1
8	Left Shoulder Top Assembly	1
9	Right Shoulder Top Assembly	1
10	Console Rack Assembly	1
11	Lower Frame Weldment	1

CHAPTER 2: ASSEMBLY GUIDE

PRE-ASSEMBLY CHECK LIST:

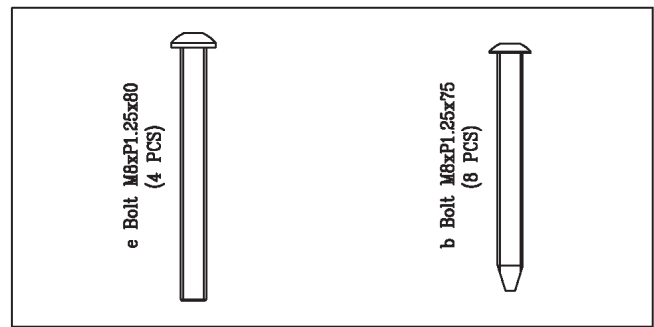
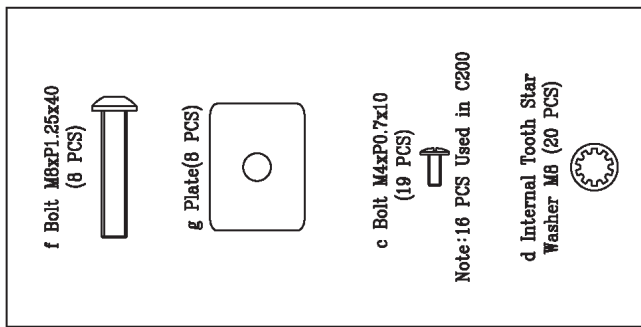
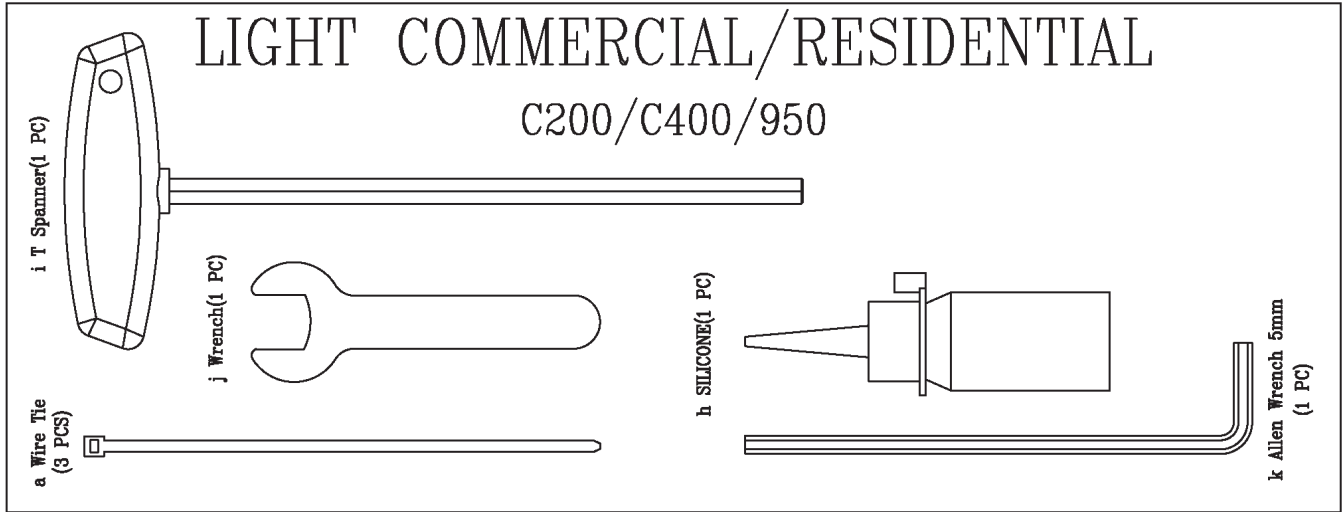

Item	Description	Qty
A	Wire Tie	3
B	M8 x P1.25 x 75	8
C	M4 x P0.7 x 10	19
D	Internal Tooth Star Washer M8	20
E	M8 x P1.25 x 80	4
F	M8 x P1.25 x 40	8

Item	Description	Qty
G	Plate	8
H	Silicone	1
I	T Spanner	1
J	Wrench (17mm)	1
K	Allen Wrench (5mm)	1

Tools Required (not included):

- Open End Wrenches: 15/16", 7/8", and 1/2"
- Hex Keys: 5/32", 3/16", 4mm, and 8mm
- Screwdrivers: #2 Phillips with 4" long tip, #2 Phillips with 8" long tip, 5/16" slotted approximately 6" long

- 7/16" 6-point socket, short extension, and ratchet
- Long-nose pliers, small (optional)
- Wire cutters, small (optional)

⚠ CAUTION:

- Use caution when assembling treadmill. Unpacking and assembling of this treadmill is a two person task.
- Remove all treadmill components from packaging.

CHAPTER 2: ASSEMBLY GUIDE

ASSEMBLY STEPS:

Step 1 (Motor Cover):

Remove the Motor Cover from the Lower Frame Weldment.

Item	Part Number	Description	Quantity
1	7PS0035	M5 x 15 Bolt	9
2	7RT0140	Motor Cover Trim	2
3	7RT0020	Motor Cover	1

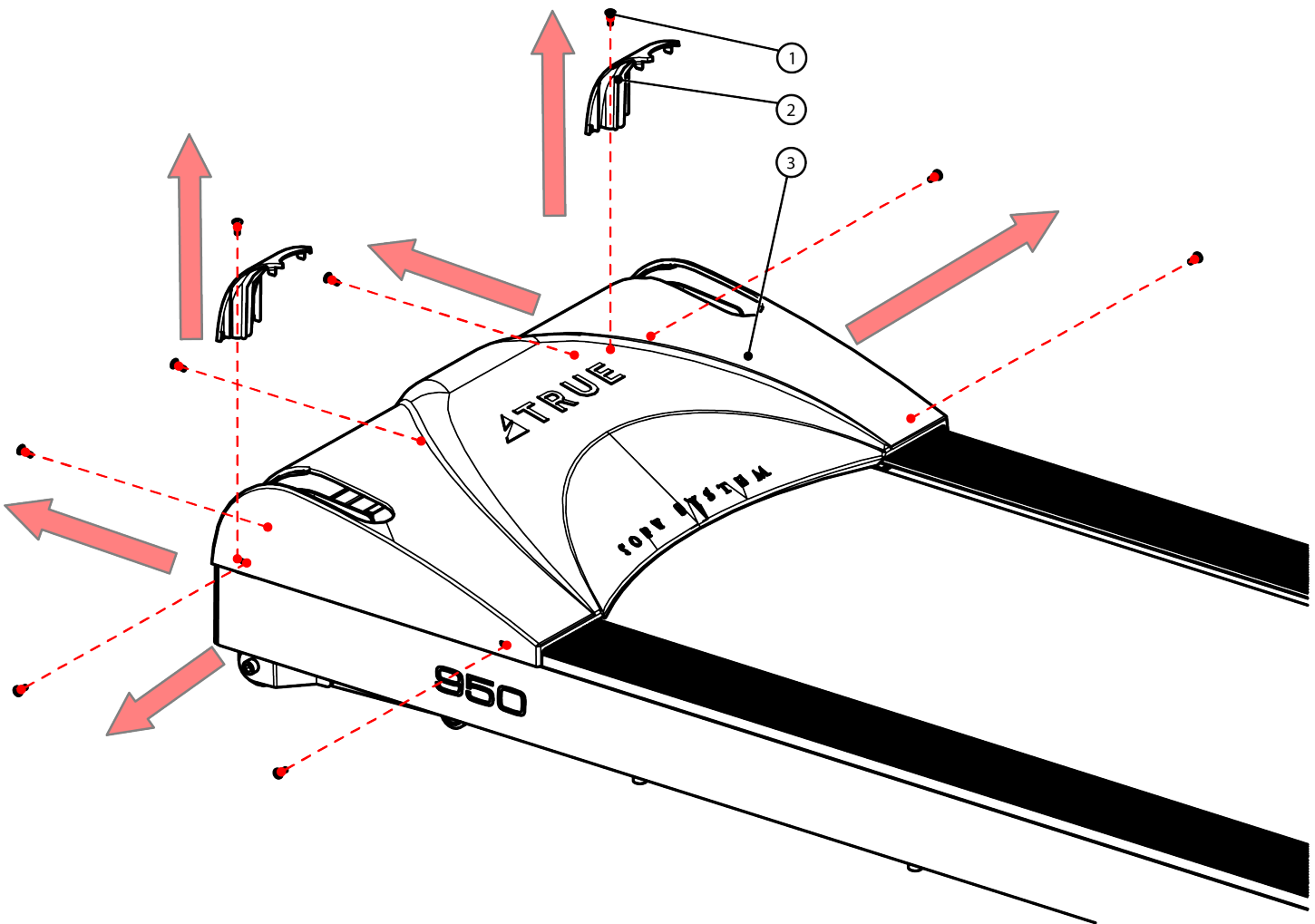

CHAPTER 2: ASSEMBLY GUIDE

ASSEMBLY STEPS:

Step 2 (Pedestals):

Assemble, but do not fully tighten, all hardware for the left and right pedestals as shown below.

Note: Confirm the cables identified in Step 3 (Lower Frame Weldment Cable Connections) are routed correctly to avoid cable pinching.

Item	Part Number	Description	Quantity
1	7PS0103	M8 x 1.25 x 75 Bolt	8
2	7RT0011	M8 Washer	8
3	7TCS4035	M10 x P1.5 x 25 Bolt	2
4	NT-2310	M10 Washer	2
5	7TC4016LBK	Left Pedestal	1
6	7TC4016RBK	Right Pedestal	1

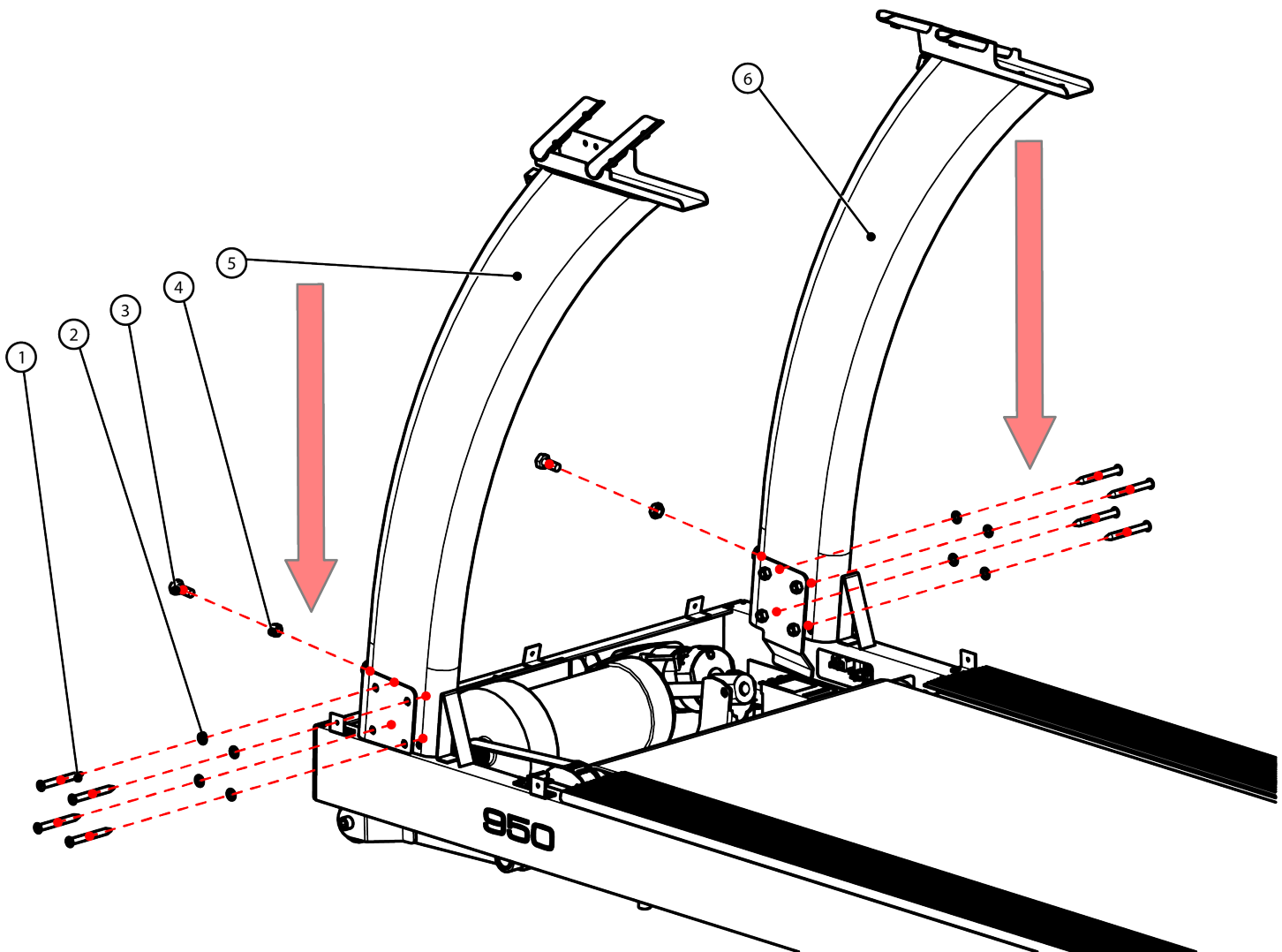

CHAPTER 2: ASSEMBLY GUIDE

ASSEMBLY STEPS:

Step 3 (Lower Frame Weldment Cable Connections):

Connect the AUXPS-I/O (Auxillary Power Supply-Input/Output) combined cable, COMM (Communication) cable, and COAX (Coaxial) cable as shown below.

TR950 cable connections without a Power Supply.

Note the auxillary power supply connection between the AUXPS cable and the AUXPS-I/O combined cable. Ensure the AUXPS cable is routed underneath the Incline Motor mounting bracket.

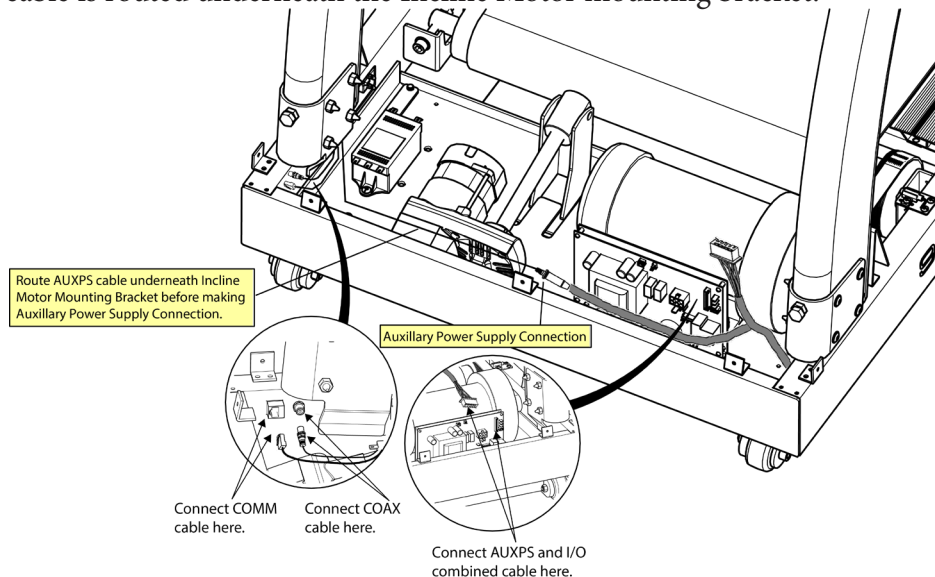

TR950 cable connections with a Power Supply.

Note the auxillary power supply connection between the AUXPS cable and Power Supply cable.

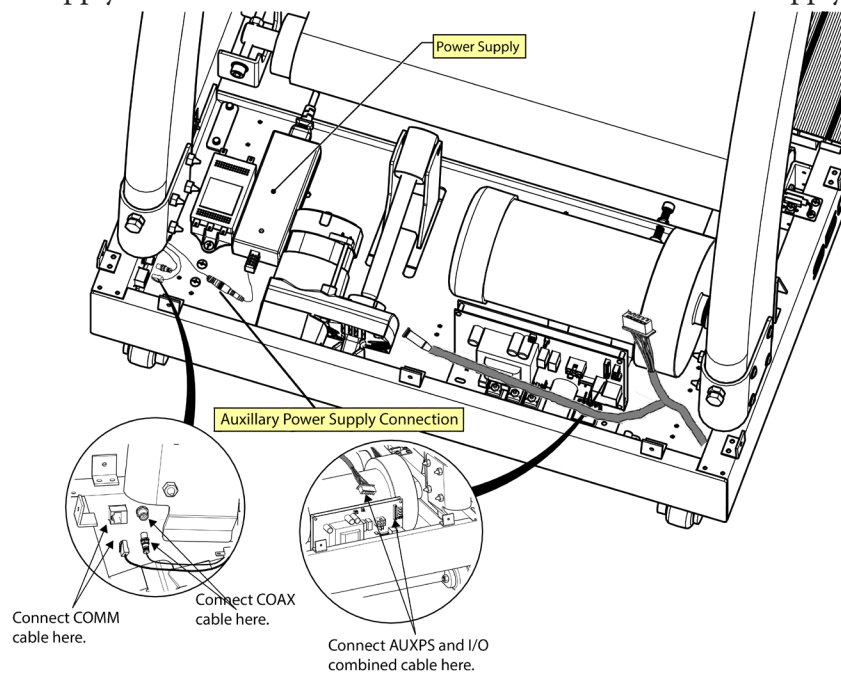

CHAPTER 2: ASSEMBLY GUIDE

ASSEMBLY STEPS:

Step 4-1 (Console Rack):

Secure the Console Rack to the Left and Right Pedestals using the required hardware as shown below.

Item	Part Number	Description	Quantity
1	7TC4017BK	Console Rack	1
2	NO-4827	Console Rack Mounting Plate	8
3	7RT0011	M8 Washer	8
4	7PS0034	M8xP1.25x40 Bolt	8

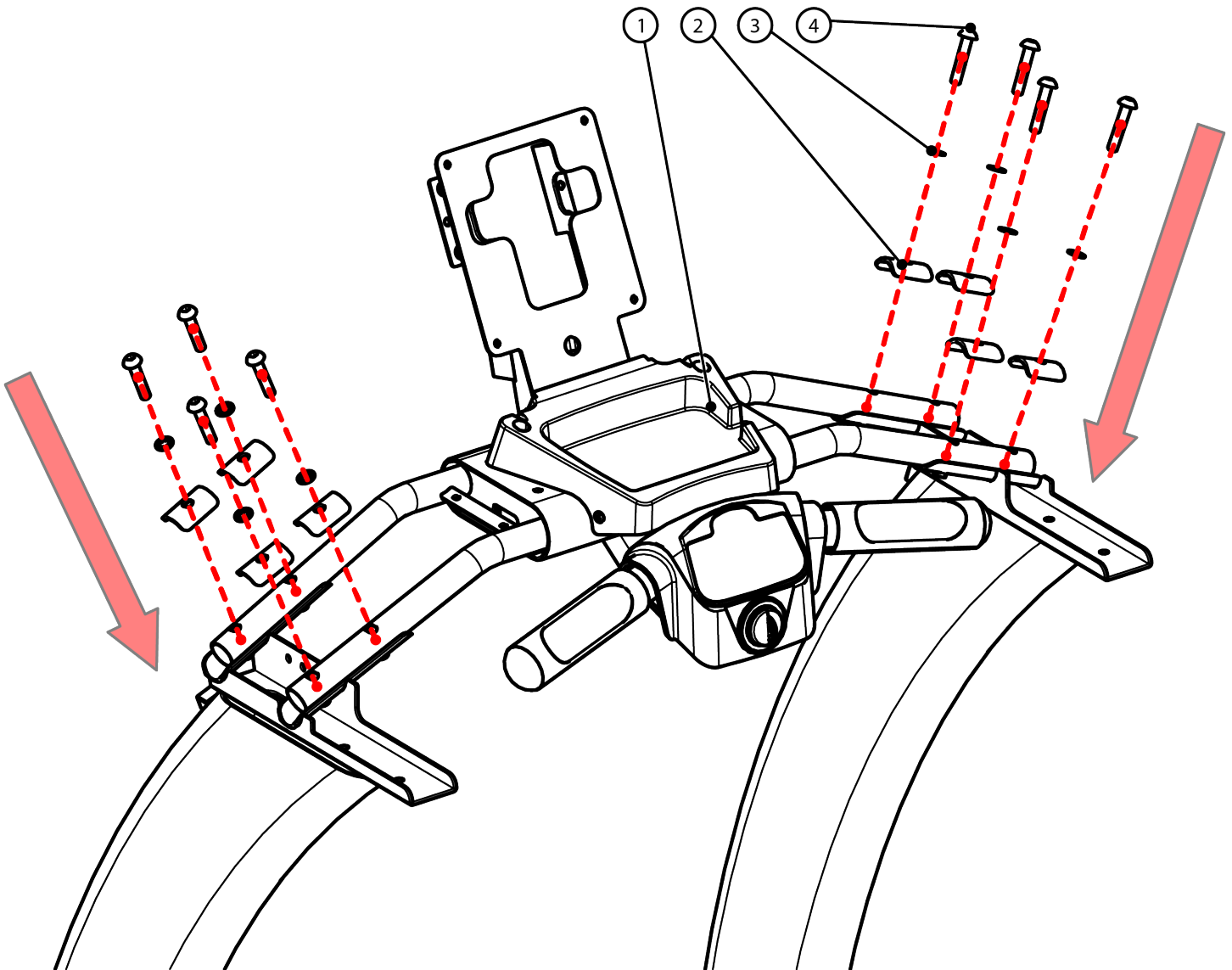

CHAPTER 2: ASSEMBLY GUIDE

ASSEMBLY STEPS:

Step 4-2 (Pedestals):

Tighten all hardware from Step 2 (Pedestals).

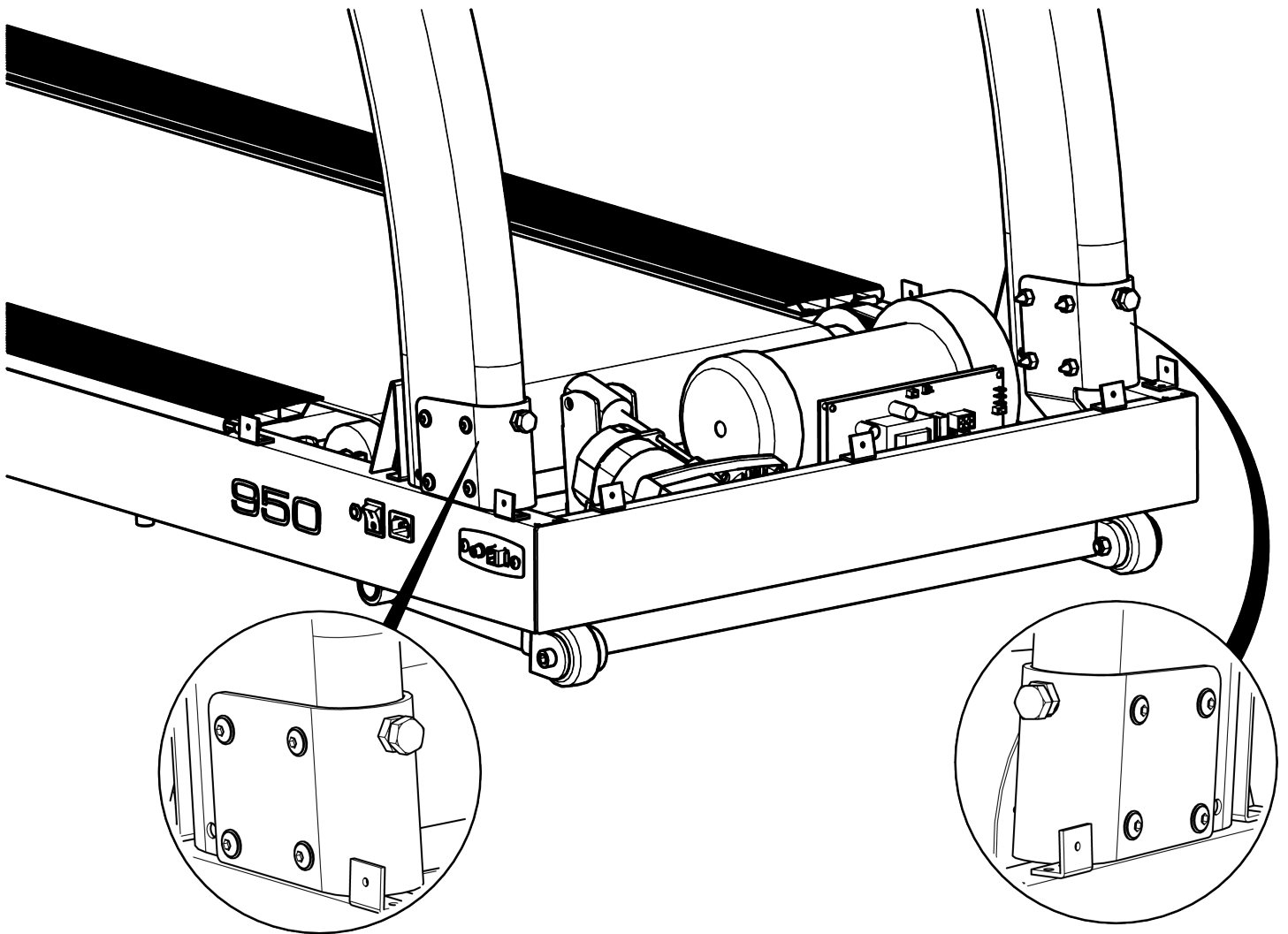

CHAPTER 2: ASSEMBLY GUIDE

ASSEMBLY STEPS:

Step 5 (Motor Cover):

Secure the Motor Cover to the Lower Frame Weldment using the required hardware as shown below.

Item	Part Number	Description	Quantity
1	7RT0140	Motor Cover Trim	2
2	7PS0035	M5 x 15 Bolt	9
3	7RT0020	Motor Cover	1

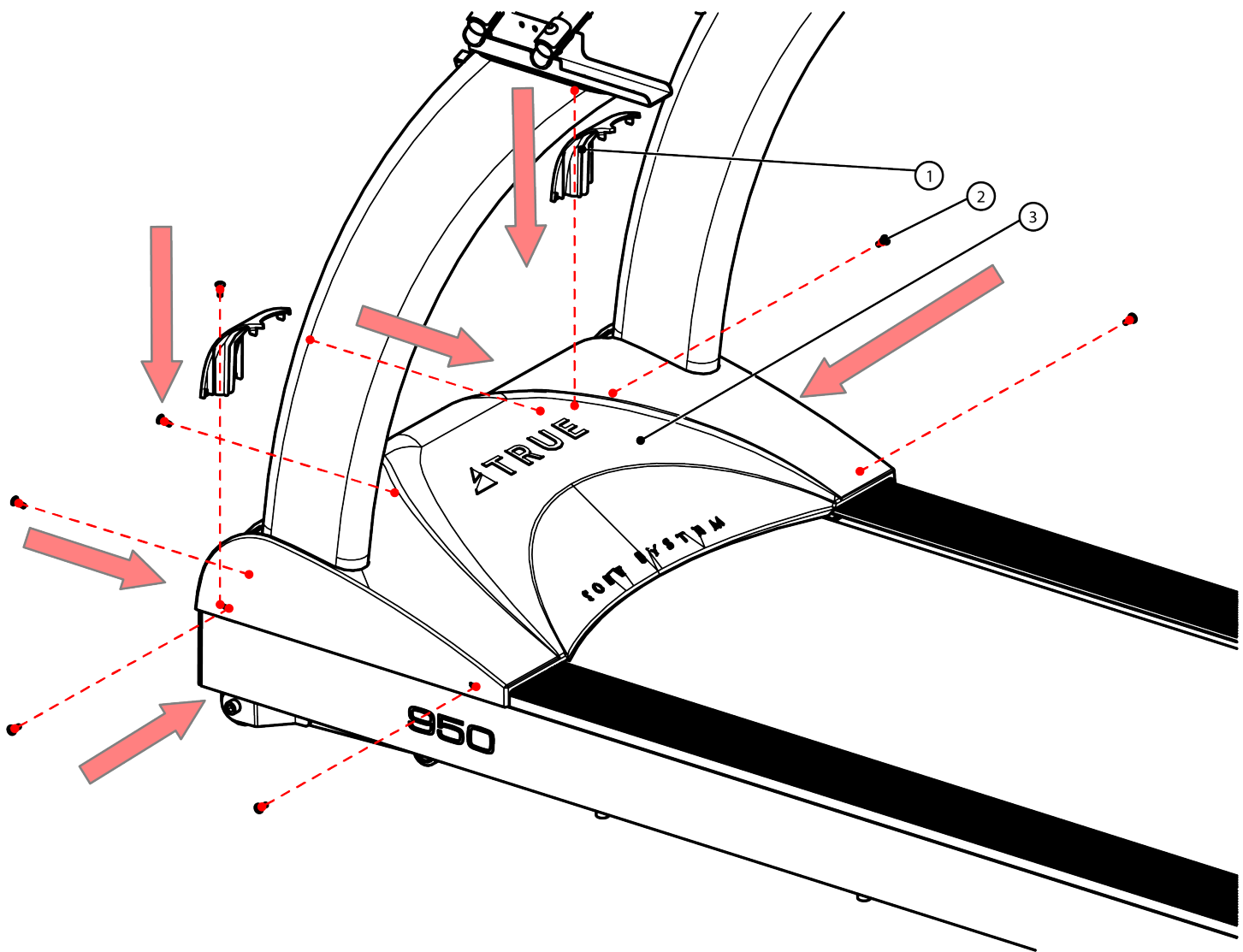

CHAPTER 2: ASSEMBLY GUIDE

ASSEMBLY STEPS:

Step 6 (Console Rack Cable Connections):

Connect the AUXPS (Auxillary Power Supply), I/O (Input/Output), COMM, and COAX cables as shown below. Note the I/O cable is located on the left side of the Console Rack and the COMM, COAX, and AUXPS cables are located on the right side of the Console Rack.

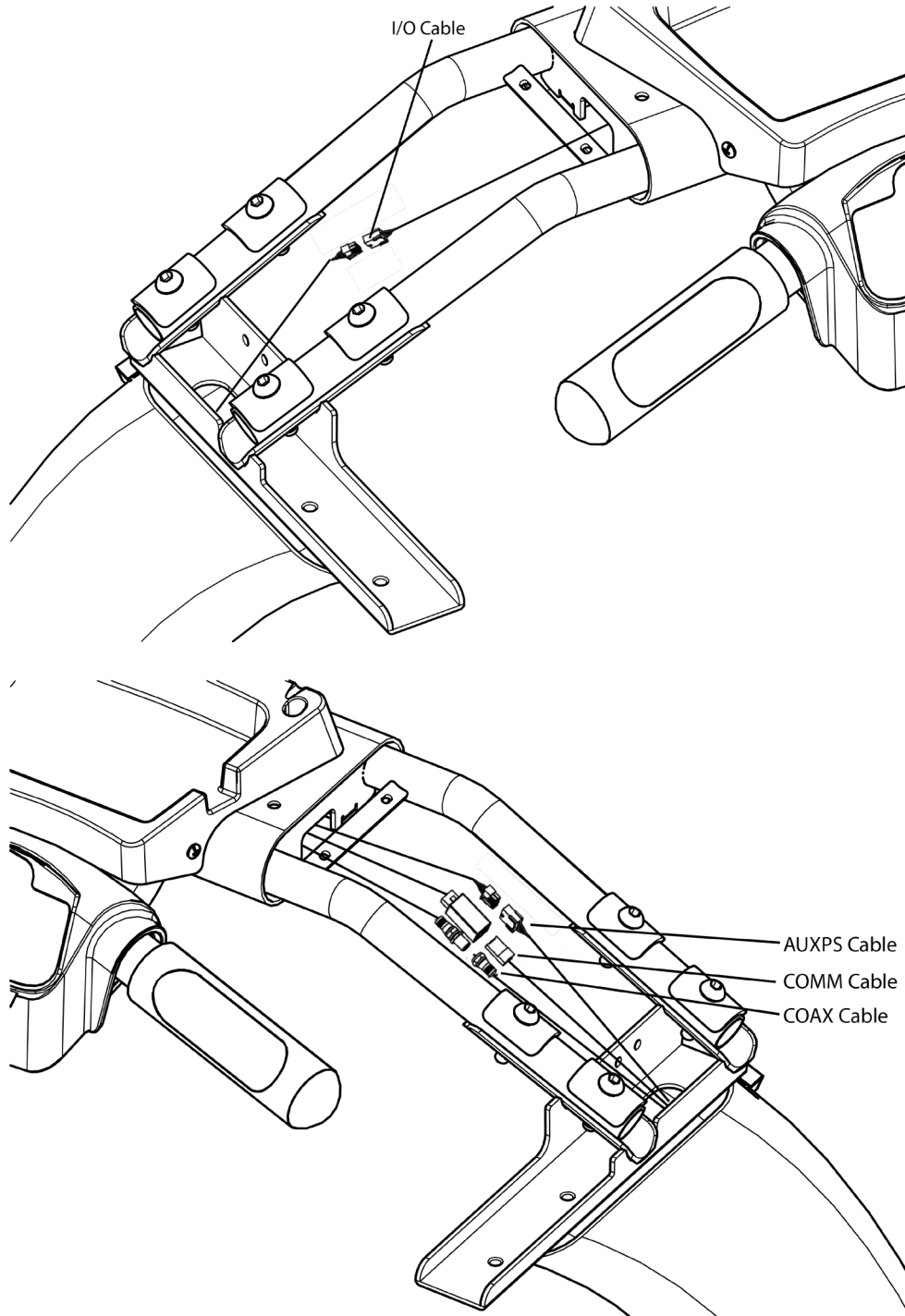

CHAPTER 2: ASSEMBLY GUIDE

ASSEMBLY STEPS:

Step 7 (Handrail Assemblies):

Secure the Left and Right Handrail Assemblies to the Console Rack using the identified hardware as shown below.

Item	Part Number	Description	Quantity
1	7TC4018R	Right Handrail Assembly	1
2	7RT0011	M8 Washer	4
3	7TCS4028	M8 x P1.25 x 80 Bolt	4
4	7TC4018L	Left Handrail Assembly	1

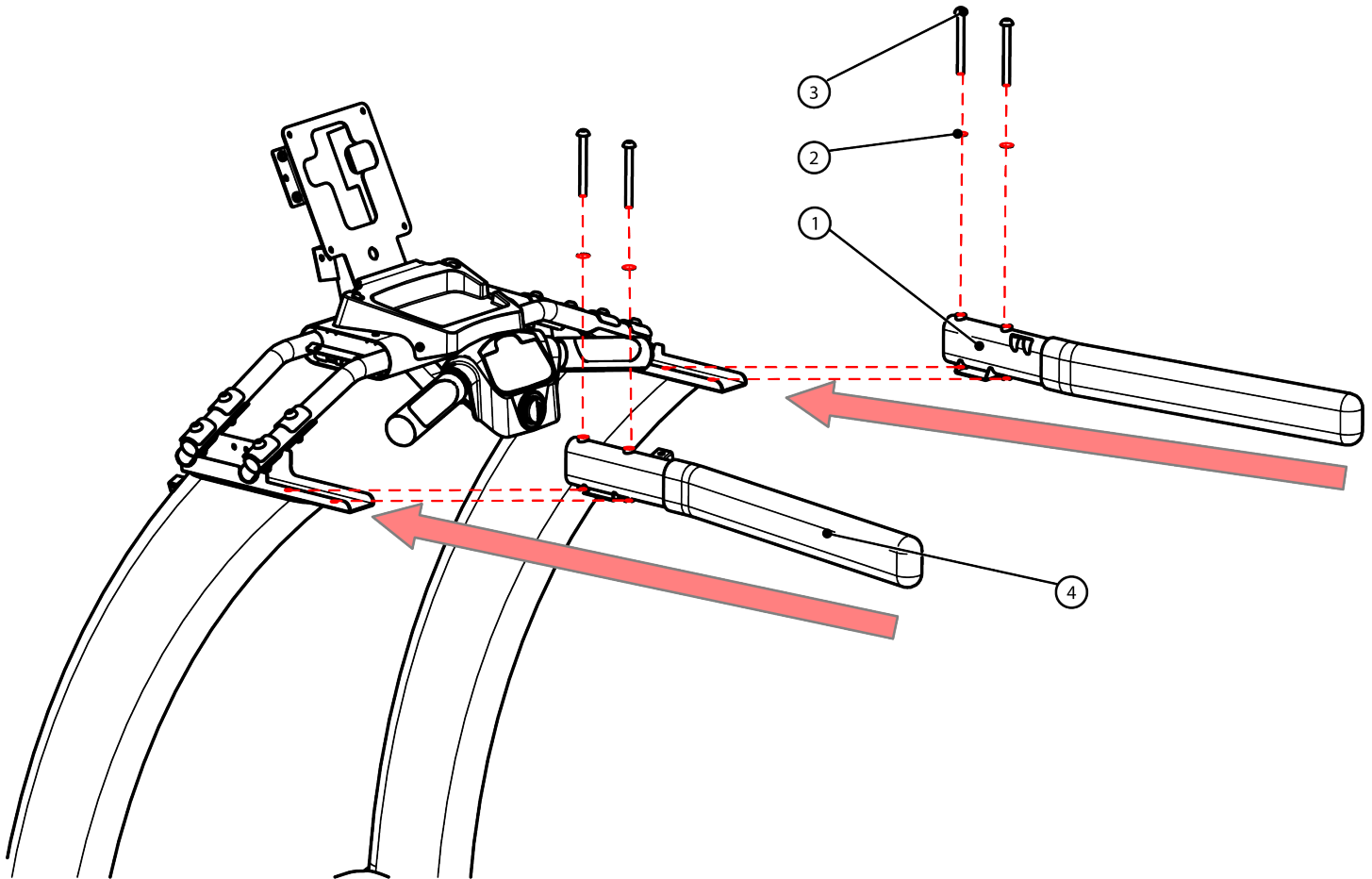

CHAPTER 2: ASSEMBLY GUIDE

ASSEMBLY STEPS:

Step 8 (Shoulder Top Assemblies):

Secure the Left and Right Shoulder Top Assemblies to the Console Rack using the identified hardware as shown below.

Item	Part Number	Description	Quantity
1	7TC4023LBK	Left Shoulder Top Assembly	1
2	7TCS4029	M4 x P0.7 x 10 Bolt	6
3	7TC4023RBK	Right Shoulder Top Assembly	1

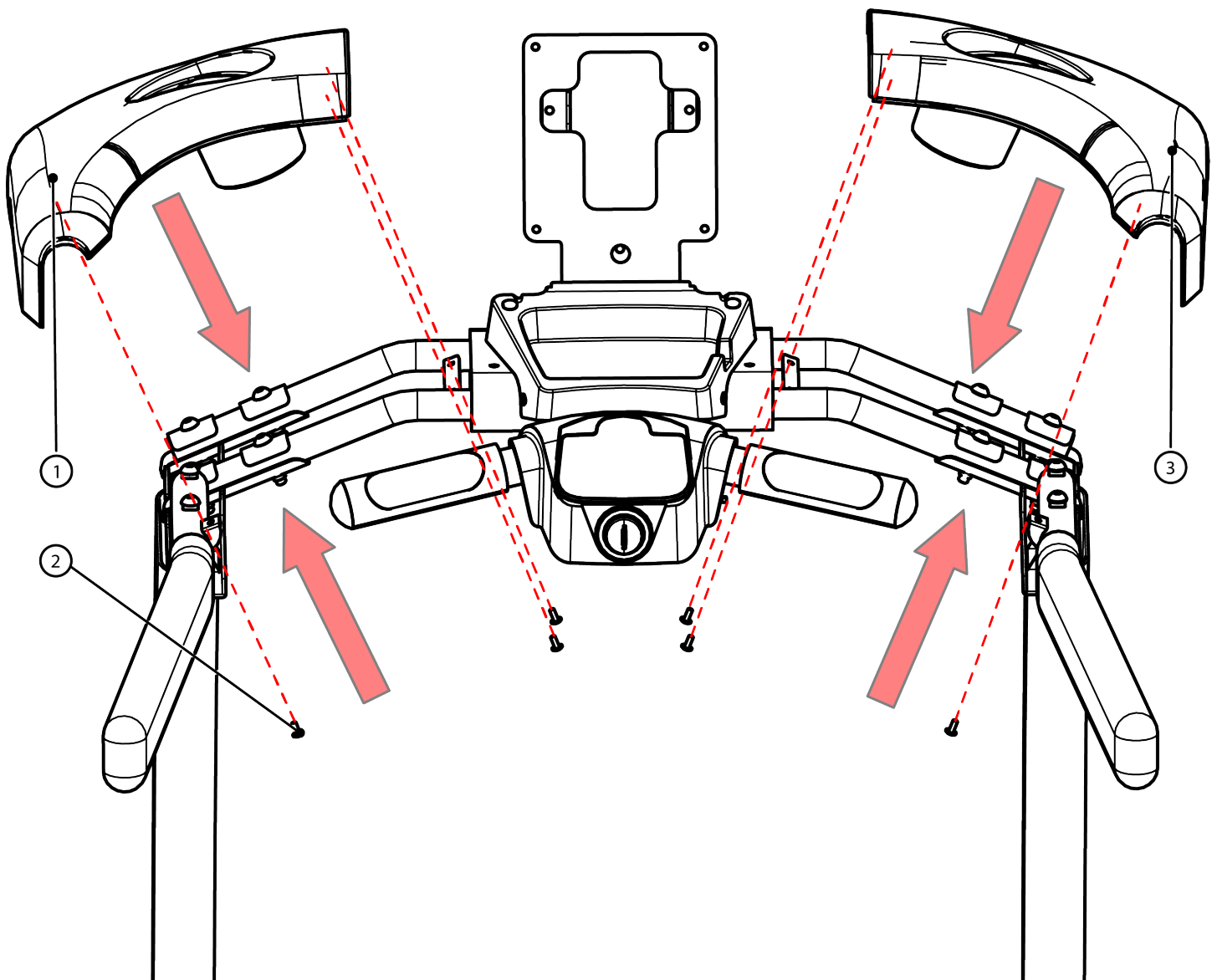

CHAPTER 2: ASSEMBLY GUIDE

ASSEMBLY STEPS:

Step 9 (Shoulder Bottom Assemblies):

Secure the Left and Right Shoulder Bottom Assemblies to the Console Rack using the required hardware as shown below.

Item	Part Number	Description	Quantity
1	7TC4022LBK	Left Shoulder Bottom Assembly	1
2	7TC4022RBK	Right Shoulder Bottom Assembly	1
3	7TCS4029	M4 x P0.7 x 10 Bolt	10

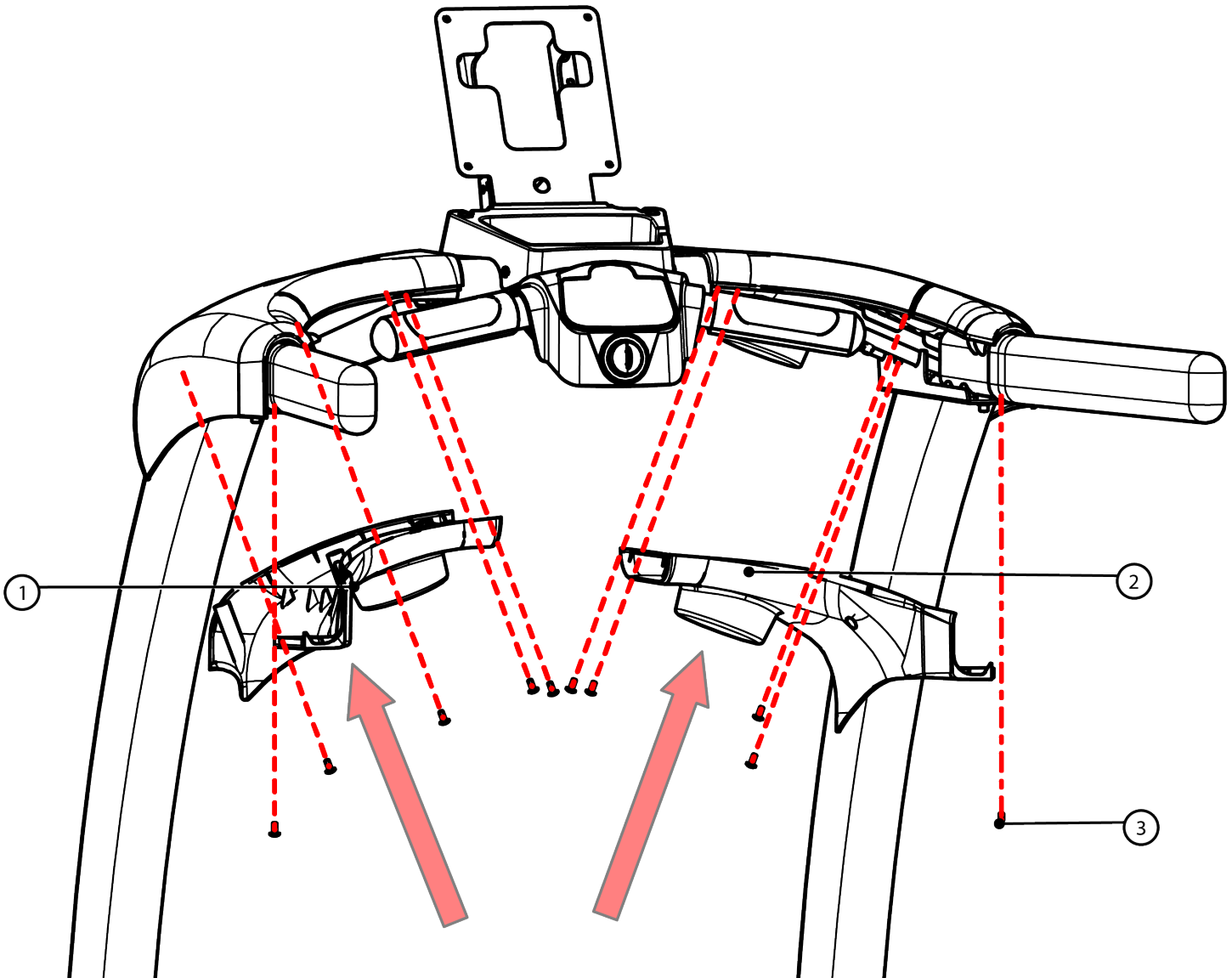

CHAPTER 2: ASSEMBLY GUIDE

ASSEMBLY STEPS:

Step 10 (Console Mast):

Secure the selected console to the Console Mast using the required hardware as shown below.

Item	Part Number	Description	Quantity
1	7TCS4029	M4 x P0.7 x 10 Bolt	4

Note: Refer to the respective console manual included with your console for wiring connections.

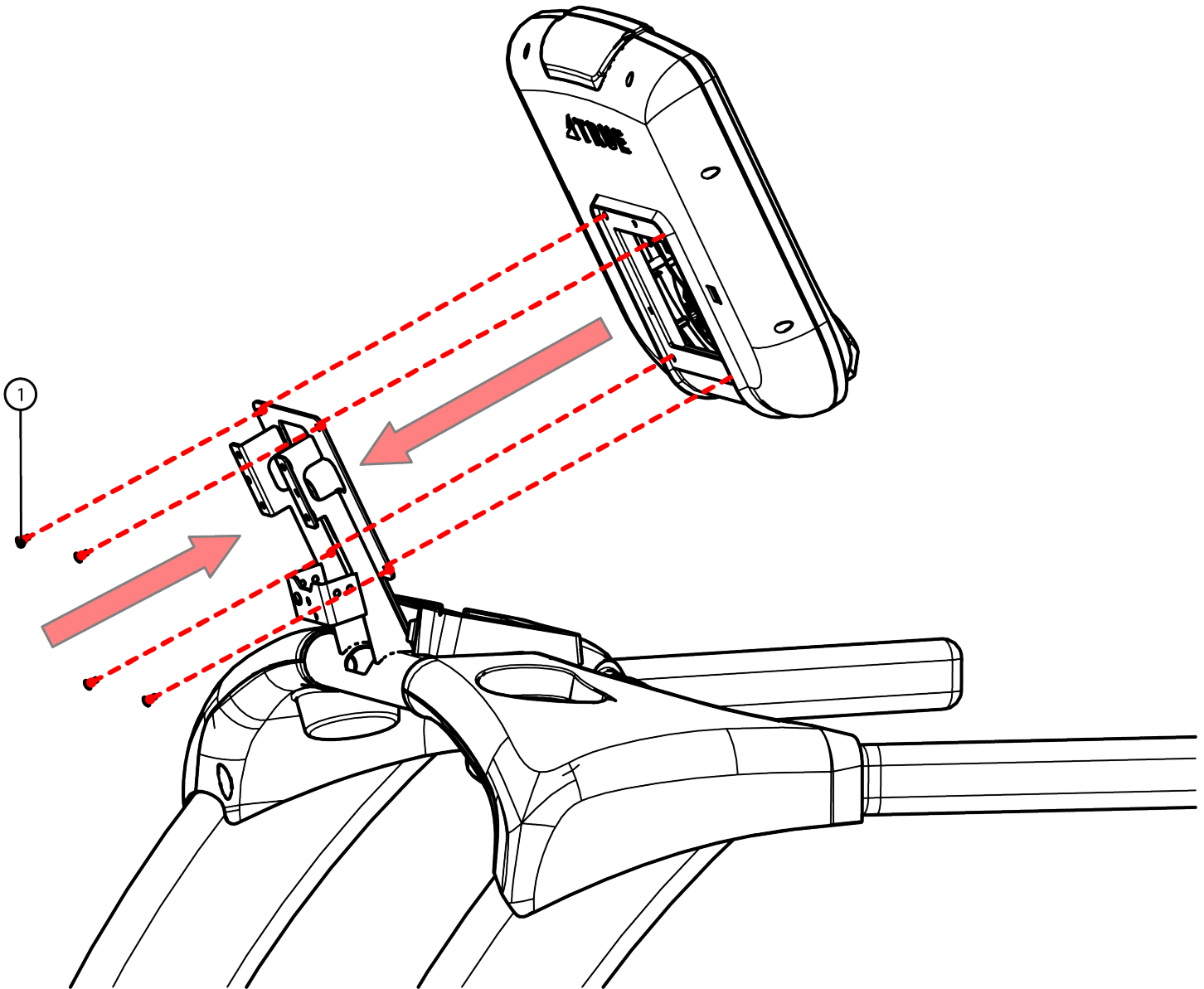

CHAPTER 2: ASSEMBLY GUIDE

ASSEMBLY STEPS:

Step 11 (Rear Console Cover Assembly):

Secure the Rear Console Cover Assembly to the Console Mast using the required hardware as shown below.

<u>Item</u>	<u>Part Number</u>	<u>Description</u>	<u>Quantity</u>
1	7TCS4029	M4 x P0.7 x 10 Bolt	3
2	7TC4033BK	Rear Console Cover Assembly	1

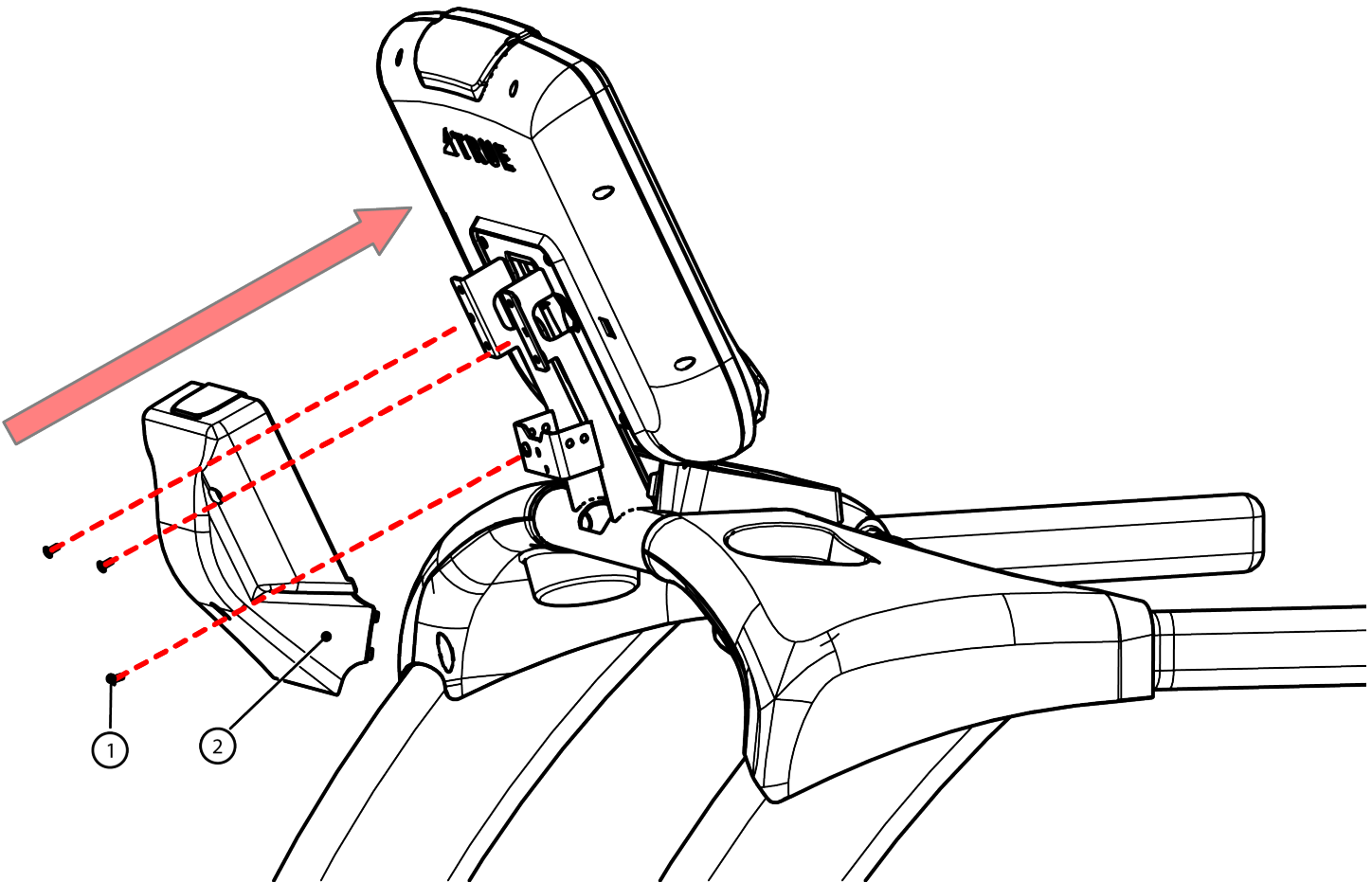

CHAPTER 2: ASSEMBLY GUIDE

ASSEMBLY STEPS:

Step 12 (Power Cord Installation):

Insert Power Cord into Power Inlet shown to the right.

POWER SWITCH: — = ON, O = OFF

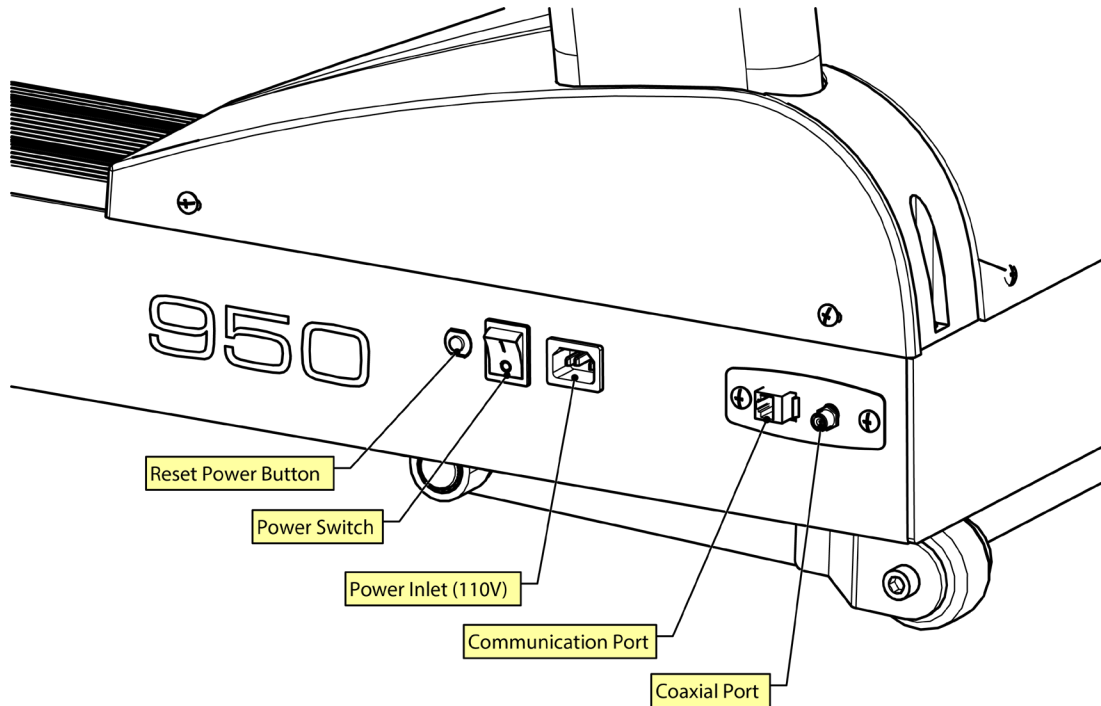

CIRCUIT BREAKER: In the event the current drawn by the treadmill exceeds a specified value, the Circuit Breaker portion of the power on/off switch will operate. The rocker lever will automatically release and position itself to a position half way between on and off, thus opening the power circuit.

If this should occur, please wait 10 minutes and then reset the Circuit Breaker by rocking the power switch fully to the OFF position (O), and then rocking the power switch back to the ON position (-). If it does not reset, or the Circuit Breaker operates again under normal use, contact True Fitness at 1-800-883-8783.

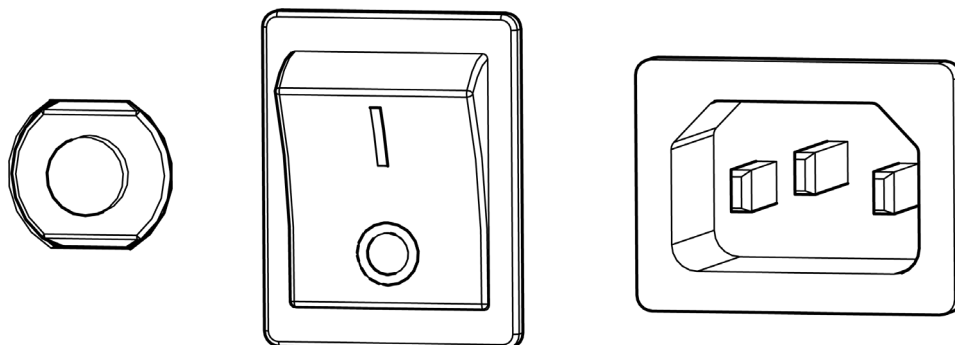

Note: The above picture shows the power switch in the OFF (O) position for reference.

CHAPTER 2: ASSEMBLY GUIDE

ASSEMBLY STEPS:

Step 13 (Unit Leveling):

Ensure treadmill incline rack wheels and rear feet are resting on the floor and not on cardboard, packaging, etc.

Using a 15/16 inch open end wrench, loosen nut A on Right Rear Foot (only side adjustable).

Using a level or estimating by sight, turn section B of foot clockwise, or counter-clockwise, using a 7/8 inch open end wrench to level the rear of treadmill.

Tighten nut A until it is secured against bottom of treadmill. Note: The recommended gap between (A) and (B) is 1/4" on a flat floor.

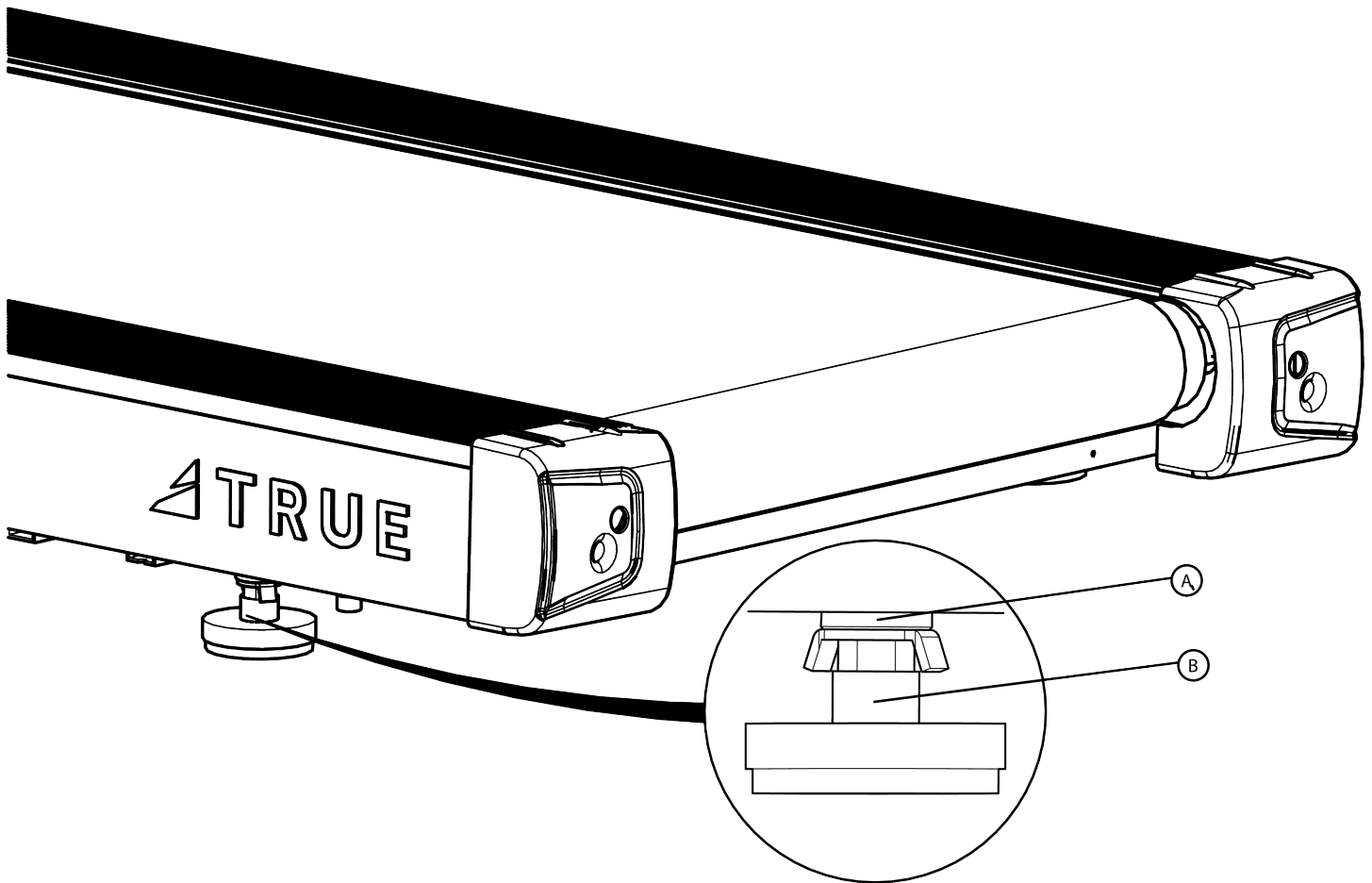

CHAPTER 2: ASSEMBLY GUIDE

ASSEMBLY STEPS:

Step 14 (Attach Safety Key):

Unwind safety key and cord from plate. Note: The safety key and attachment cord are wrapped around plate during shipping as shown.

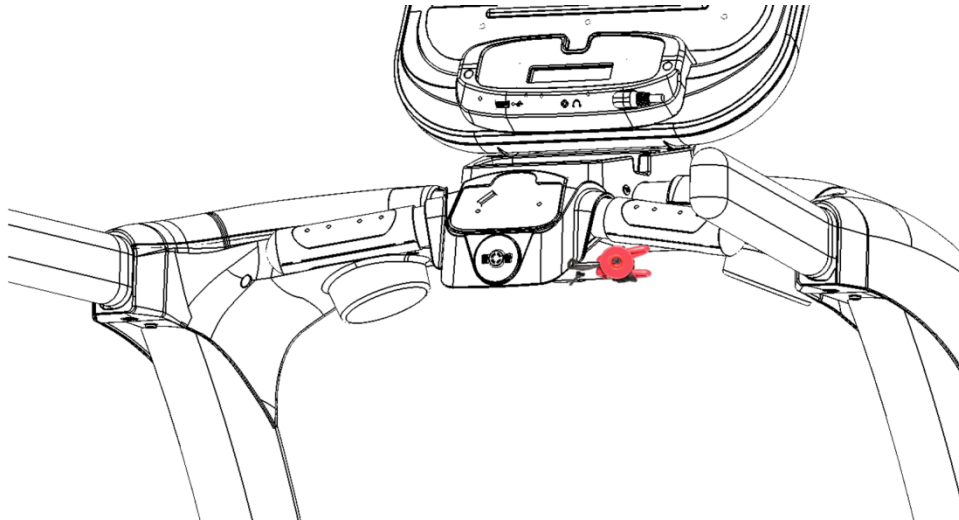

Attach Safety Key magnet to front of Center Pod as shown.

Attach Safety Key clip to plate located on Console Rack (when not working out).

Attach clip to clothing at the beginning of any workout.

CAUTION: Read treadmill Owner's Manual before attempting any workout.

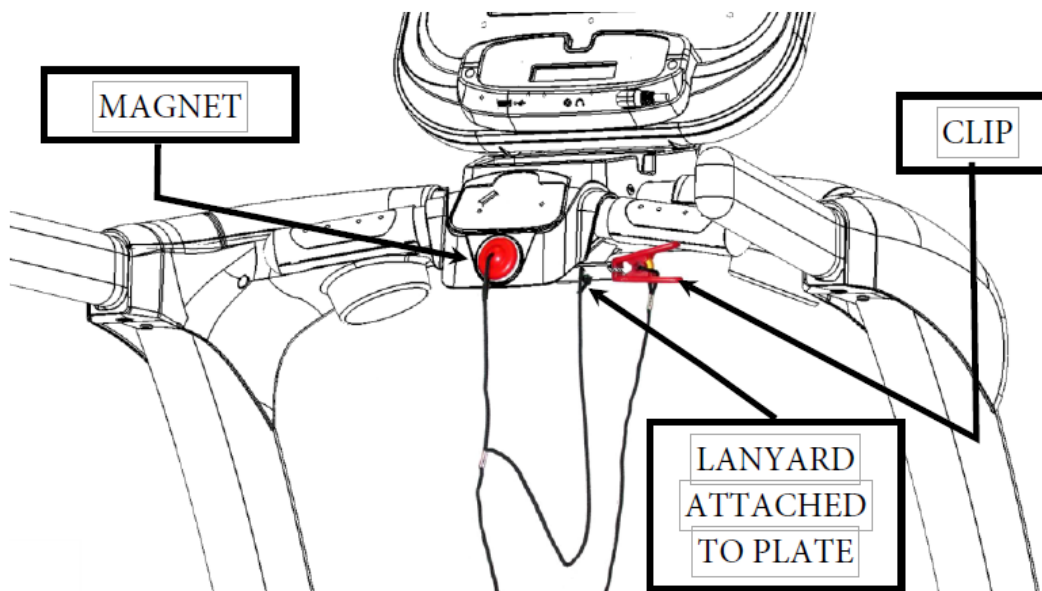

CHAPTER 3: PRODUCT OVERVIEW



CHAPTER 3: PRODUCT OVERVIEW

Console Assembly:

The console allows the user to set up a workout program and control the treadmill during a workout (For console overview and operation instructions refer to the respective console manual).

Quick Access Keys:

Allows the user to quickly start, stop and wake the treadmill or make fast, convenient adjustments to the incline level or speed of the treadmill.

Contact Heart Rate Pads:

Allows the user to check their heart rate without wearing a wireless chest strap.

*For increased safety and accuracy this feature should only be used when the belt speed is below 4 mph.

Safety (E-Stop) Key:

A tethered safety device designed to attach to both the user and the console. Removal of the key from the console will stop belt motion to prevent injury in an emergency.

*The safety key must be in place on the treadmill and should be attached to the user's clothing. The treadmill will not operate if the safety key is not attached to the treadmill.

Belt:

The moving surface of the treadmill on which the user walks or runs.

Straddle Covers:

Stationary covers on either side of the belt, which allows the user to safely straddle the belt during startup or in the event of an emergency.

Belt Adjustment Bolts:

An adjustment system that allows the users to adjust the belt tracking and tension as needed.

On/Off Switch:

Allows users or faculty to turn the power on or off to the treadmill.

Circuit Breaker:

A safety device designed to protect the treadmill from excessive electrical current.

Power Cord:

Delivers power from the wall outlet to the treadmill.

Leveling Feet:

An adjustable system used to aid in the leveling of the treadmill.

CHAPTER 4: CARE & MAINTENANCE

CARE & MAINTENANCE:

It is important to perform the minor maintenance tasks described in this section. Failure to maintain the treadmill as described here could void the TRUE Fitness Warranty. To reduce the risk of electrical shock, always unplug the unit from its power source before cleaning or performing any maintenance tasks.

Inspection:

TRUE Fitness is not responsible for performing or scheduling regular maintenance or inspections. Users should inspect the treadmill daily. Check for worn, frayed or missing safety lanyards. Replace missing or worn safety lanyards immediately. Do not exercise on the treadmill without attaching the safety clip to your clothing. Look and listen for slipping belts, loose fasteners, unusual noises, worn or frayed power cords, and any other indications that the equipment may be in need of service. If any of these are noticed, obtain service. Do not attempt to use the treadmill until proper service has been performed or damaged parts have been replaced.

Important:

If you determine that the treadmill needs service, make sure that the treadmill cannot be used inadvertently. Turn the unit off, and then unplug the power cord from its power source. Remove the magnetic safety key and safety clip and store it in a safe place. Make sure other users know that the treadmill needs service.

*To order parts or to contact a TRUE Authorized Service representative, please visit www.truefitness.com.

CLEANING THE EQUIPMENT:

After Each Use:

- Use GymWipes™ Antibacterial wipes or spray a solution of 30 parts water to 1 part mild detergent to dampen a soft cloth and wipe all exposed surfaces.
- Use a LCD/screen cleaner or spray a solution of 1 part 91% isopropyl alcohol and 1 part water to dampen a soft cloth and wipe the surface of the console. This helps remove fingerprints, dust, and dirt.

Weekly:

- Vacuum any dust or dirt that might have accumulated under or around the treadmill, any motor cover vents and under the straddle covers. Clogged air vents can prevent adequate cooling to the drive motor, incline motor, and motor control board causing a shortened life.
- Check for proper running belt alignment and tension. If running belt adjustment is required, see sections “RUNNING BELT ALIGNMENT” and “TENSIONING THE RUNNING BELT” in the following pages.

CAUTION:

Do not use any acidic cleaners. Doing so will weaken the paint or powder coatings and may void the TRUE Fitness Warranty. Never pour water or spray liquids on any part of the treadmill. Allow the treadmill to dry completely before using. Frequently vacuum the floor underneath the unit to prevent the accumulation of dust and dirt, which can affect the smooth operation of the unit. Use a soft nylon scrub brush to clean the running belt. Do not clean directly underneath the treadbelt. Most of the working mechanisms are protected inside the motor cover and base of the treadmill. However, for efficient operation, the treadmill relies on low friction. To keep the friction low, the unit's running belt, staging platforms, and internal mechanisms must be as clean as possible.

CHAPTER 4: CARE & MAINTENANCE

RUNNING BELT ALIGNMENT:

Proper belt alignment allows the belt to remain centered and ensures smooth operation. Realigning the belt takes a few simple adjustments. If you are unsure about this procedure, call the TRUE Service Department.

⚠️ CAUTION:

Special care must be taken when aligning the running belt. Turn off the treadmill while adjusting or working near the rear roller. Remove any loose clothing and tie back your hair. Be very careful to keep your fingers and any other object clear of the belt and rollers, especially in front of the roller and behind the deck. The treadmill will not stop immediately if an object becomes caught in the belt or rollers.

⚠️ CAUTION:

If you hear any chafing or the running belt appears to be getting damaged, stop the running belt immediately by pressing the STOP key. Contact the TRUE Service Department. Walk around to the rear of the unit and observe the belt for a few minutes. The belt should be centered on the running deck. If the belt drifts off center, you must make adjustments.

Important:

Failure to align the belt may cause the belt to tear or fray, which may not be covered under the TRUE Fitness Warranty. To stop the running belt, press the STOP key. Turn the treadmill off.

⚠️ CAUTION:

For your safety, use the power switch to turn off the treadmill before making any adjustments. Do not adjust the running belt when someone is standing on the unit.

⚠️ CAUTION:

Do not turn the adjusting bolt more than 1/4 turn at a time. Over tightening the bolt can damage the treadmill. If you are unsure how to adjust the running belt, call the TRUE Service Department.

Note: When running belt is properly aligned, people can see the belt locating at the center of the belt alignment slot.

The slot is located on the rear roller guard.

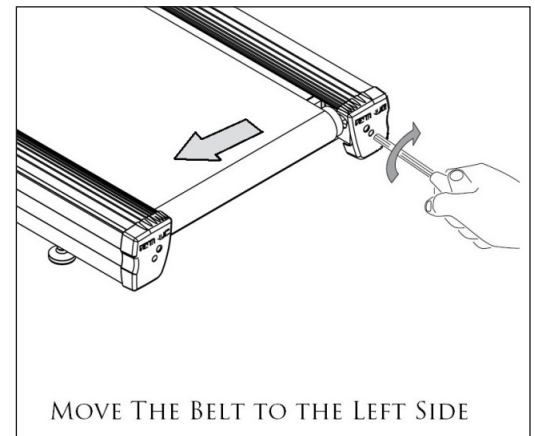

If the running belt is too far to the right side:

- Locate the belt adjustment bolts in the rear end caps of the treadmill. (To determine left and right, stand at the rear of the treadmill and face the display).
- Using the appropriate size Allen wrench or socket turn the RIGHT adjustment bolt clockwise ¼ turn.
- Turn the treadmill on and start the belt at 3mph keeping off the unit.
- Allow 2 minutes for the belt to adjust itself.
- Repeat the above steps if additional adjustment is necessary.

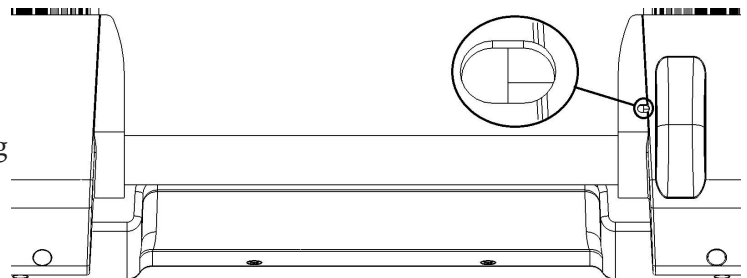

CHAPTER 4: CARE & MAINTENANCE

If the running belt is too far to the left side:

- Locate the belt adjustment bolts in the rear end caps of the treadmill. (To determine left and right, stand at the rear of the treadmill.)
- Using the appropriate size Allen wrench or socket turn the LEFT turn.
- Turn the treadmill on and start the belt at 3mph keeping off the belt.
- Allow 2 minutes for the belt to adjust itself.
- Repeat the above steps if additional adjustment is necessary.

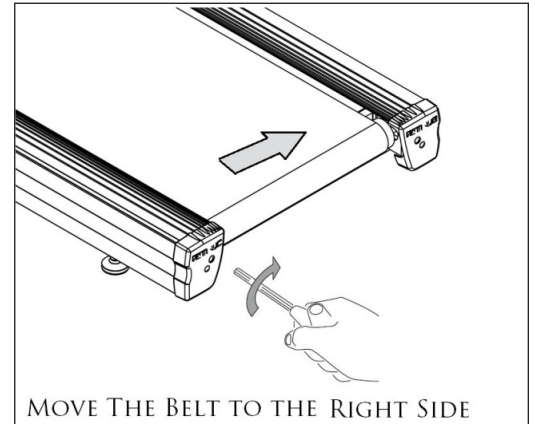

Note: After the running belt alignment is complete, confirm the Allen wrench has been removed from the adjustment bolt in the front belt cover before further use.

TENSIONING THE RUNNING BELT:

If there is a slipping or jerking sensation when running on the treadmill, the running belt may require tightening. In most cases the belt has stretched from use. Tensioning the belt takes a few simple adjustments. If you are unsure about this procedure, call the TRUE Service Department.

- Locate the belt adjustment bolts in the front belt cover.
- Remove the rubber cover plugs.
- Using the appropriate size Allen wrench or socket, turn BOTH adjustment bolts clockwise $\frac{1}{4}$ turn.
- Turn the unit on, start the belt, and check if the slipping continues.
- Repeat the above steps if additional adjustment is necessary.

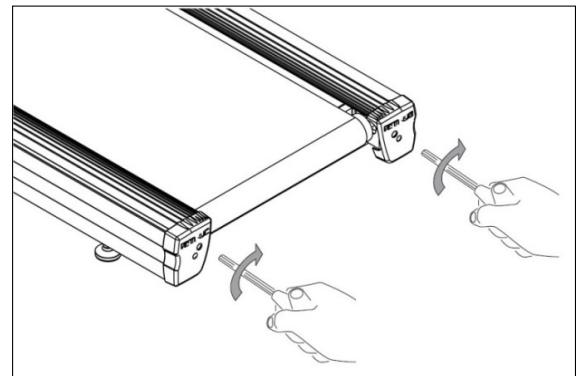

Note: After the running belt tensioning is complete, confirm both Allen wrenches have been removed from the adjustment bolts in the front belt cover before further use.

BELT LUBRICATION:

For commercial use over 20 hours per week, TRUE recommends lubricating every three months.

- Locate the belt adjustment bolts in the front belt cover
- Remove the rubber cover plugs.
- Loosen the belt adjustment bolts in the front belt cover.
- Lift the belt and apply the lubricant to the center of the deck.
- Center and re-tension the belt using the directions above.
- Walk on the unit at 2MPH for about 60 seconds to spread the lubricant evenly through the belt and deck.

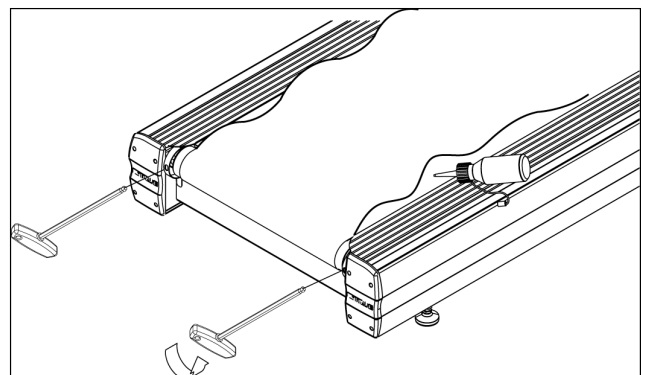

*Please contact your dealer or visit www.truefitness.com to obtain the proper lubricants.

CHAPTER 4: CARE & MAINTENANCE

LEVELING THE EQUIPMENT:

This equipment has adjustable front leveling feet to make sure that the running surface is level. If the unit is placed on an uneven surface, adjusting the front feet can help, but may not completely compensate for extremely uneven surfaces.

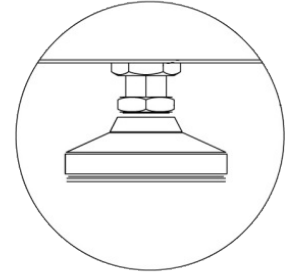

OTHER SCHEDULED PREVENTIVE MAINTENANCE:

TRUE recommends that quarterly scheduled maintenance be performed by a qualified service technician. Please contact your dealer or visit www.truefitness.com to contact a local TRUE authorized service technician.

Scheduled Preventive Maintenance:

- Record time, distance and hours from the console.
- Check error log in console.
- Check running belt and drive belt tension and tracking.
- Remove the motor cover and vacuum any debris out of the drive motor, speed sensor cage, motor control board and heat sink motor compartment.
- Move treadmill and vacuum underneath.
- Lubricate elevation pivot points including rear stabilizing feet and the lift motor screw.
- Lubricate walking belt and deck.
- Inspect all fasteners.
- Inspect all electrical connections.
- Inspect all components for abnormal or premature wear.

⚠ CAUTION:

Use only TRUE Fitness certified service providers.

LONG TERM STORAGE:

When the treadmill is not in use for any length of time, turn it off. Make sure that the power cord is unplugged from the power source and is positioned so that it will not become damaged or interfere with people or other equipment.

Storing the Chest Strap:

Store the chest strap in a place where it remains free of dust and dirt such as, in a closet or drawer. Be sure to protect the chest strap from extremes in temperature. Do not store it in a place that may be exposed to temperatures below 32° F (0° C). To clean the chest strap, use a sponge or soft cloth dampened in mild soap and water. Dry the surface thoroughly with a clean towel.

CHAPTER 5: CUSTOMER SERVICE

CONTACTING SERVICE:

TRUE Fitness recommends that you gather the serial number, model number, and a brief description of the reason for the request. After information has been gathered you may choose to contact your selling dealer or local service company to set an appointment. (If you are not familiar with who is in your area, you may visit our website at www.truefitness.com and use our dealer locator to obtain the contact information for the closest dealer).

You may also contact TRUE Fitness' customer support team by calling 800.883.8783 or e-mailing us at service@truefitness.com Monday – Friday during normal business hours.

TRUE FITNESS SERVICE DEPARTMENT

865 HOFF ROAD

ST. LOUIS, MO 63366

1.800.883.8783

HOURS OF OPERATION: 8:30 A.M. - 5:00 P.M. CST

E-MAIL: service@truefitness.com

CONTACTING SALES:

Interested in TRUE Products? Please contact us with any sales or product inquiries so that we may direct you to the appropriate sales representative to answer your questions.

TRUE FITNESS HOME OFFICE

865 HOFF ROAD

ST. LOUIS, MO 63366

1.800.426.6570

HOURS OF OPERATION: 8:30 A.M. - 5:00 P.M. CST

E-MAIL: sales@truefitness.com

CHAPTER 5: CUSTOMER SERVICE

REPORTING FREIGHT OR PARTS DAMAGE:

Unfortunately, sometimes materials can be damaged during shipment. If materials are damaged during shipment, please follow the guidelines below to determine the appropriate process for you to follow in case of damages.

Severe Damage:

Obvious damage to external packaging / internal product. Please **refuse** the shipment and it will be returned to TRUE Fitness by the carrier. Contact the TRUE Fitness customer support team by calling 800.883.8783 or sales support team by calling 800.426.6570 Monday-Friday during normal business hours to notify us that the shipment has been refused. Once we have received the damaged shipment, a replacement shipment will be sent to you. Only refuse the damaged piece if the shipment is multiple boxes.

Slight Damage:

The box may have minimal damages and you are not sure if the actual product is damaged or not. You **must** sign the bill of lading as damaged when accepting the shipment. Once you have opened the box and you have determined something is indeed damaged please gather the serial number, model number, description and photos of damages. Please make sure the photos include the damaged product as well as the damaged box the product arrived in. Contact the TRUE Fitness customer support team by calling 800.883.8783 or sales support team by calling 800.426.6570 Monday-Friday during normal business hours.

Concealed Damage:

You may receive a shipment that looks intact and discover once the box has been opened that there are hidden damages. Please notify the carrier **immediately**. We will not be able to file a claim if the carrier is not notified in a timely manner. Once you have called the carrier you will need to gather the serial number, model number, description and photos of damages. Contact the TRUE Fitness customer support team by calling 800.883.8783 or sales support team by calling 800.426.6570 Monday-Friday during normal business hours.

CHAPTER 6: ADDITIONAL INFORMATION

TR950-20 Treadmill

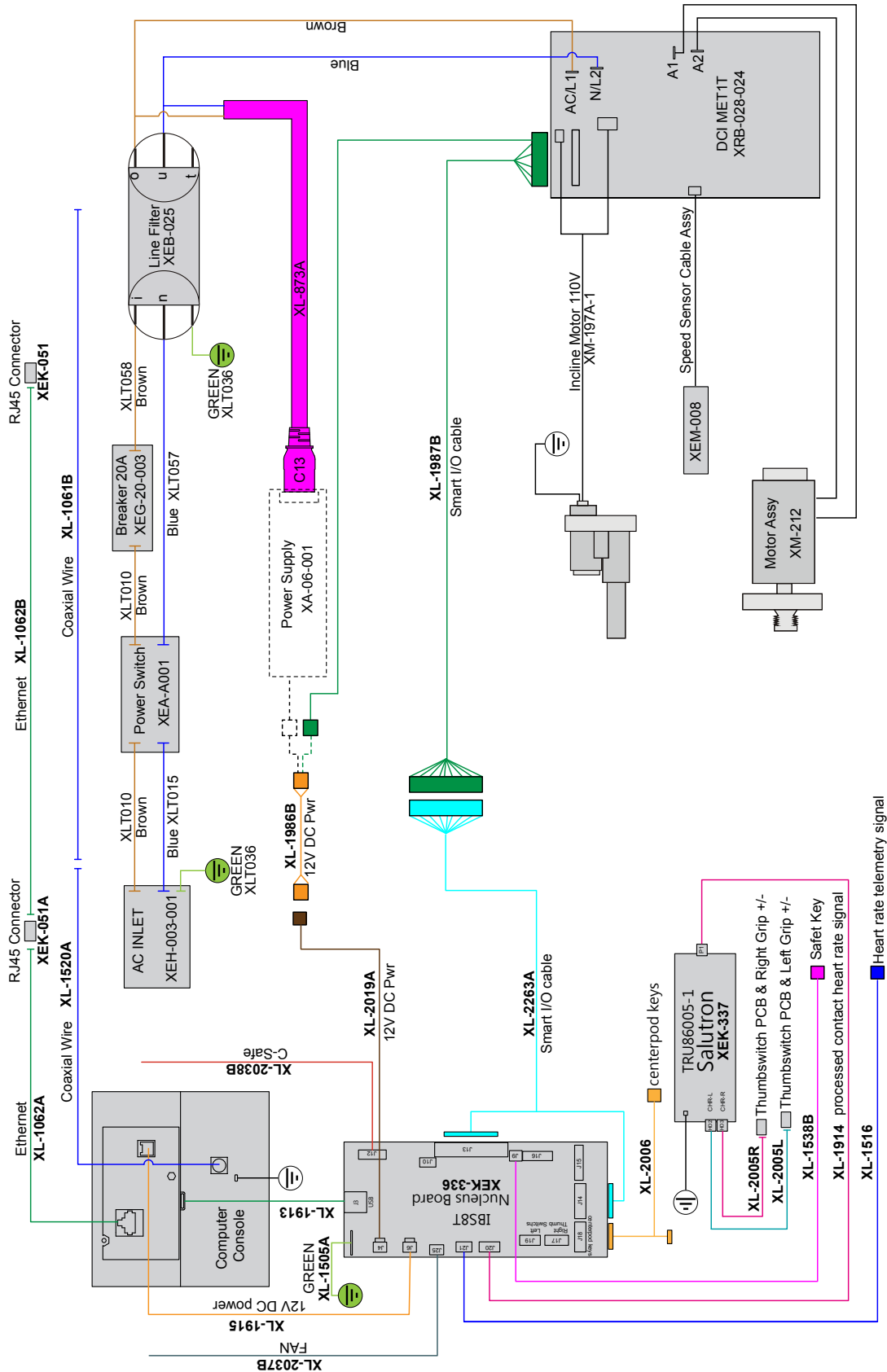

CHAPTER 6: ADDITIONAL INFORMATION

TROUBLESHOOTING GUIDE:

This troubleshooting guide is intended to assist in diagnostics only and is not all inclusive. Technical specifications, error codes and programming are subject to change without notice. TRUE accepts no liability for any damage or loss suffered by persons whom rely wholly or in part on any description or statement contained within this manual. Please visit www.TRUEfitness.com to obtain the most recent version of all manuals and contact the TRUE Service Department at 800-883-8783 for assistance with troubleshooting and diagnostics.

Malfunction	Possible Cause	Corrective Action
No Power	Unit turned off	Verify the On/Off switch is at the ON position
	Damaged power cord	Replace power cord
	Power cord not fully seated in socket	Inspect power connection at the unit and outlet
	No power at outlet	Using a voltmeter verify power at outlet
	Tripped circuit breaker	The location of the circuit breaker is next to the On/Off switch. Verify the circuit breaker is not open. If the breaker is open reset.
Unit resets or pauses randomly	Damaged power cord	Replace power cord
	Power cord not fully seated in socket	Inspect power connection at the unit and outlet
	Safety e-stop key not fully engaged	Re-engage the safety/e-stop key to the console
	Insufficient power	Verify output voltage from 20A outlet with a voltmeter
	Error code is displayed on console	Contact TRUE Fitness Customer
	Pinched or loose main communication cable	
Walking belt is off center	No User Present displayed on screen	User weight must be over 90lbs. Verify No User Present settings in console.
	Uneven floor	Adjust treadmill with rear leveling feet. See Chapter 5: Running Belt Alignment
Walking belt hesitates or slips when stepping	Adjust belt tracking	See Chapter 5: Centering the Running Belt
	Adjust belt tension	See Chapter 5: Tensioning the Running Belt
Rubbing sound from treadmill when in operation	Lubricate running belt	See Chapter 5: Treadmill Lubrication
	Walking belt is rubbing a straddle cover	Adjust belt tracking. See Chapter 5: Centering the Running Belt
	Foreign object may be stuck under walking belt	Inspect under the unit. Remove and object that may be under the unit.
	Foreign object may be stuck in motor compartment	Contact TRUE Fitness Customer Service Department
	Roller bearings may be damaged	
	Drive motor may be damaged	
Drive belt may be misaligned		

CHAPTER 6: ADDITIONAL INFORMATION

Malfunction	Possible Cause	Corrective Action
Heart rate is displaying erratically or not displaying	Transmitter belt contacts are not making good contact with the skin	Re-adjust the transmitter belt so that it is in full contact with the skin
	Contacts on the transmitter belt are not moist	Moisten the contacts on the transmitter belt
	Transmitter belt is not within 3 feet (1 meter) of the heart rate receiver	Adjust your position on the belt so that you are within 3 feet (1 meter) of the console
	The battery inside the transmitter belt is depleted	Replace the transmitter belt with a compatible transmitter belt
	Another user wearing a compatible transmitter strap is within 3 foot (1 meter) of the unit	Move the units so that there is more space in-between units
	Environmental interference from high voltage power lines	Move the unit to another position within the room or move the cause of the interference until heart rate reading are stable. If the probable source of interference is plugged into the same outlet move the suspect source to another outlet.
	Environmental interference from computers	
	Environmental interference from motor driven appliances	
	Environmental interference from cell or cordless phone	
Environmental interference from Wi-Fi router		

Fault Code	Category	Description	Cause	Corrective Action
Fault CN00: Corrupted Console Configuration	Console	Corrupted brainboard configuration - fails integrity check	Corrupt software	Power cycle
				Re-configure console
			Firmware and software versions are not compatible	Re-install software/firmware Contact dealer or TRUE service
Fault CN01: Internal Fault	Console	Math error - software	Console Configure Incorrectly	Power cycle
				Re-configure console
			Corrupt Software	Re-install software/firmware Contact dealer or TRUE service
Fault CN02: Invalid Console Configuration	Console	The product configuration data has failed validation checks (incline ranges make no sense, etc.)	Console Configure Incorrectly	Power cycle
				Re-configure console
			Incline Motor out of range Loose Cable	Contact Dealer or TRUE service

CHAPTER 6: ADDITIONAL INFORMATION

Fault CN03: Stuck Key	Console	Membrane Key stuck down/closed	Membrane key is damaged	Contact dealer or TRUE service
Fault CN04: Lower Board Comm Fault (Treadmill Only)	Console	Brainboard fails to receive timely communication responses from lower board - Fault after 3 retries	Loose Cable	Power cycle
			Smart Card, MCB, or Console	Contact dealer or TRUE service
Fault CN05: No Lower Control	Console	No lower board connected to console - detection wires not connected.	Loose Cable	Power cycle
			Console Configure Incorrectly	Check Cable Connection
Fault CN06: Config Mismatch	Console	Console is configured for a product different than that to which it is connected.	Console Configure incorrectly	Re-configure console
			Loose Cable	Check cable connections
Fault CN07: Calibration Timeout	Console	Incline Calibration was not able to complete within allowed time.	Low AC Line Voltage	Retry calibration
				Verify AC Voltage at Outlet
Fault CN08: Calibration Failed - Lower Limit Not Reached	Console	During incline calibration, the incline stalled before reaching what should be the lower limit.	Console displays Fault Calibration not saved. Incline disabled.	Power cycle
			Incline Potentiometer value out of range	Check cable connections
				Contact dealer or TRUE service
Fault CN09: Insert Safety Key	Console	Emergency Circuit opened	Safety Key not engaged	Re-insert safety key
			Loose Cable	Check cable connections
			Switch Damaged	Contact dealer or TRUE service
Fault CN10: E-Stop Fault	Console	A test of the emergency circuit has failed	Console Catch	Power cycle
			Safety Key not engaged	Reinsert safety key
			Loose Cable	Check cable connections
			Switch Damaged	Contact dealer or TRUE service
Fault CN24: BB Comm Fault	Console	SBC cannot communicate with Brainboard	Console	Power cycle
				Contact dealer or TRUE service
Fault CN25: Firmware Mismatch	Console	Firmware on brainboard not compatible with SBC software	Corrupt software	Power cycle
				Reconfigure Console
			Firmware and software versions are not compatible	Contact dealer or TRUE service

CHAPTER 6: ADDITIONAL INFORMATION

Fault SP01: Belt Under Speed	Speed	Tread motor rpm is below target rpm	High Belt Deck Friction	Lubricate treadmill
			High Belt Tension	Contact dealer or TRUE service
			Low Line Voltage	Check drive belt and walking belt tension
			Dirty or misaligned speed sensor	Contact dealer or TRUE service
Fault SP02: Belt Over Speed	Speed	Tread motor rpm is higher than target rpm	High Belt Deck Friction	Lubricate treadmill
			Line Voltage	Contact dealer or TRUE service
			Dirty or misaligned speed sensor	Check AC line voltage
Fault SP03: Belt Over Accel	Speed	Tread belt speed increasing too quickly	User is holding belt back	Do not try to stop belt
			High Belt Deck Friction	Lubricate treadmill
			Dirty or misaligned speed sensor	Contact dealer or TRUE service
Fault SP04: No Speed Signal	Speed	Speed sensor is not providing speed data	Dirty or misaligned speed sensor	Contact dealer or TRUE service
			High Belt Deck Friction	Lubricate treadmill
			Low Line Voltage	Contact dealer or TRUE service
Fault IN01: Incline Stall	Incline	Incline not moving when commanded	Console displays Fault Calibration not saved. Incline disabled.	Power cycle
				Check cable connections
				Run incline calibration
			Incline Potentiometer value out of range	Contact dealer or TRUE service
Acme Nut Jammed				
Fault IN02: Incline Out of Range	Incline	Incline value is out of the calibrated range - does not occur during calibration	Console displays Fault Calibration not saved. Incline disabled.	Power cycle
				Check cable connections
				Run incline calibration
			Incline Potentiometer value out of range	Contact dealer or TRUE service
Fault IN03: Incline Run Fault	Incline	Incline moving when not commanded	Console displays Fault Calibration not saved. Incline disabled.	Power cycle
				Check cable connections
				Run incline calibration
			Incline Potentiometer value out of range	Contact dealer or TRUE service

CHAPTER 6: ADDITIONAL INFORMATION

Fault IN04: Incline Max/Min	Incline	Incline value is out of expected operating range - may indicate that it is disconnected.	Console displays Fault Calibration not saved. Incline disabled.	Power cycle
				Check cable connections
				Run incline calibration
			Incline Potentiometer value out of range	Contact dealer or TRUE service
Fault D100: Motor Controller Fault	DC MCB	Motor Control Board Fault	Motor Control Board	Power cycle
				Contact dealer or TRUE service
Fault D101: Lower Board Communication Fault	DC MCB	Endex did not receive communication from BB in 18 seconds	Loose cable connection	Power cycle
				Check cable connections
			Motor Control Board	Contact dealer or TRUE service
Upper display/console				
Fault D103: Motor Controller Fault	DC MCB	Low Incoming AC Voltage	Low AC Line Voltage	Power cycle
				Check AC line voltage
Fault D104: Motor Controller Fault	DC MCB	Motor Control Board Fault	Motor Control Board	Power cycle
				Contact dealer or TRUE service
Fault D106: Motor Controller Fault	DC MCB	High Incoming AC Voltage	High AC line voltage	Check AC line voltage
			Motor Control Board	Power cycle
				Contact dealer or TRUE service
		High belt/deck friction	Lubricate treadbelt	
Fault D107: Motor Over Current	DC MCB	High Incoming AC Voltage	High AC line voltage	Check AC line voltage
Fault D108: Motor Over Current	DC MCB	High Incoming AC Voltage	High AC line voltage	Check AC line voltage
			Motor Control Board	Power cycle
				Contact dealer or TRUE service
		High belt/deck friction	Lubricate treadbelt	

CHAPTER 6: ADDITIONAL INFORMATION

Fault D109: Motor Controller Zero Current	DC MCB	Low Incoming AC Voltage	Low AC Line Voltage	Power cycle
				Contact dealer or TRUE service
Fault D110: Motor Controller Overcurrent	DC MCB	High Incoming AC Voltage	High AC line voltage	Check AC line voltage
			Motor Control Board	Power cycle
			High belt/deck friction	Contact dealer or TRUE service
Fault D111: Motor Controller Voltage Overload	DC MCB	Low Incoming AC Voltage	Low AC Line Voltage	Lubricate treadbelt
				Power cycle
				Check AC line voltage
Fault D112: Motor Controller Undervoltage	DC MCB	Low Incoming AC Voltage	Low AC Line Voltage	Contact dealer or TRUE service
				Power cycle
				Check AC line voltage
Fault D113: Motor Controller Control Fault	DC MCB	Incline Stall - incline not moving when commanded	Console displays Fault Calibration not saved. Incline disabled.	Power cycle
				Check cable connections
				Run incline calibration
			Contact dealer or TRUE service	
Fault D114: Lower Board Incline Range Fault	DC MCB	Incline out of range	Console displays Fault Calibration not saved. Incline disabled.	Incline Potentiometer value out of range
				Acme Nut jammed
				Motor bearings
			Contact dealer or TRUE service	

CHAPTER 7: WARRANTY INFORMATION

Save Time and Register Online!
Activate Multiple Warranties at truefitness.com

All TRUE® Fitness products are distributed by TRUE and are warranted to the original registered product purchaser and the parts of the TRUE product (the "Product") listed below, under normal use and service, shall be free of manufacturing defects in workmanship and materials only for the period of time beginning from the original date of purchase set forth below:

Frame*	Lifetime
Drive Motor	30 Years
Parts	
Touchscreen Console	3 Years
LED Console	3 Years
Electrical	10 Years
Wear Items	10 Years
Cosmetics	6 Months
Labor	
Parts	1 Year
Motor	1 Year
Cosmetics	6 months
Device Connectivity	
Headphone Jack & USB Port	90 Days Parts, No Labor

NOTE: Warranty valid for USA and Canada only.

NOTE: Failure to register this product will result in no servicing or authorization of parts to be shipped.

NOTE: Buying after-market products from a 3rd party will result in voided warranty.

NOTE: This product is intended for Residential use. If this product will not be used in this particular setting, please contact TRUE as is warranty is void.

Frame

The frame is warranted for defects in material and workmanship for as long as the original purchaser owns the Product. The frame is warranted for labor and freight (for part shipped from TRUE) for one year from date of purchase. * This limited warranty on structural frame does not include paint or coatings.

Parts

The treadmill electrical parts and wear items are warranted for defects in material and workmanship for ten years with one year labor warranty. The Touchscreen consoles and LED consoles are warranted for defects in material and workmanship for three years with three years labor warranty. This limited warranty does not cover damage or equipment failure resulting from or caused by improper assembly/ installation, failure to follow instructions and warnings in

owner's manual, accident, misuse, abuse, unauthorized modification, or failure to provide reasonable and necessary maintenance. This limited warranty will apply to but may not be limited to the treadmill elevation motor, upper control board, deck, running belt and drive belt. *TRUE Fitness shall not warrant the performance of the heart rate system on its products, as the heart rate system performance varies, based on user's physiology, age, method of use and other factors. * This limited warranty shall not apply to Software version upgrades.

Cosmetics

The treadmill cosmetic parts are warranted for defects in material and workmanship for six months with labor warranty to match the parts warranty period. This limited warranty does not cover damage or equipment failure resulting from or caused by improper assembly/installation, failure to follow instructions and warnings in owner's manual, accident, misuse, abuse, unauthorized modification, or failure to provide reasonable and necessary maintenance. This limited warranty will apply to but may not be limited to paint/coatings, covers/ caps, badges, overlays, safety key and straddle covers.

Device Connectivity

Device Connectivity elements; headphone jack and USB Port are warranted for defects in material and workmanship for 90 days with no labor warranty.

Labor

Labor is covered for a period of one year from the date of purchase unless otherwise expressed within this limited warranty as long as a TRUE authorized service provider performs the service. Service that requires over 50 miles of travel may be subject to additional charges. Reasonable and necessary maintenance includes proper lubrication of the running deck and tread belt area as specified in the owner's manual.

Claims Procedure

TRUE Limited Warranty service may be obtained by contacting the authorized TRUE dealer from whom the Product was purchased. If the dealer from whom the Product was purchased is no longer an authorized TRUE dealer, then TRUE Limited Warranty service may be obtained by contacting TRUE directly at:

TRUE Fitness, Service Department
865 Hoff Road, St. Louis, MO 63366
1-800-883-8783
Hours of operation 8:30am - 5:00 pm CST

CHAPTER 7: WARRANTY INFORMATION

Save Time and Register Online!

Activate Multiple Warranties at truefitness.com

1. THIS LIMITED WARRANTY GIVES YOU SPECIFIC LEGAL RIGHTS AND YOU MANY ALSO HAVE OTHER RIGHTS, WHICH VARY FROM STATE TO STATE.

2. This Limited Warranty can be processed only if the Warranty Registration Form is completed on-line; or if the attached form is filled in, signed by the original purchaser and mailed to TRUE within 30 days of purchaser's receipt of this Product. The serial number must be intact on the Product for this Limited Warranty to be valid.

3. This Limited Warranty applies to the product only while the Product remains in the possession of the original purchaser and is not transferable.

4. This Limited Warranty becomes VALID ONLY if the Product is initially assembled/installed by a TRUE authorized dealer/ technician (if anyone other than a TRUE authorized dealer/ technician initially assembles and installs the Product, this Limited Warranty will be void unless the written authorization of TRUE is first obtained).

5. This Limited Warranty does not cover damage or equipment failure resulting from or caused by improper assembly/ installation, failure to follow instructions and warnings in owner's manual, accident, misuse, abuse, unauthorized modification, or failure to provide reasonable and necessary maintenance (as referenced in the owner's manual.)

6. This Limited Warranty applies only to the cost of repair or replacement of parts and does not include labor (beyond the above warranty period), transportation, service, return and freight charges associated therewith except as expressly specified herein.

7. This Limited Warranty shall not apply to: Service calls to correct installation of the equipment or instruction to owners on how to use the equipment; or any labor costs incurred beyond the applicable labor warranty period.

8. This Limited Warranty, which is given expressly and in lieu of all other express warranties, constitutes the only warranty made by TRUE.

9. ANY IMPLIED WARRANTY, INCLUDING WITHOUT LIMITATION THE WARRANTIES OF MERCHANTABILITY AND FITNESS FOR A PARTICULAR PURPOSE, IS LIMITED IN DURATION AND REMEDY TO THE TIME PERIOD COVERED BY THE LIMITED WARRANTY. SOME STATES DO NOT ALLOW LIMITATIONS ON HOW LONG AN IMPLIED WARRANTY LASTS, SO THE ABOVE LIMITATION MAY NOT APPLY TO YOU.

10. THE REMEDIES DESCRIBED ABOVE ARE YOUR SOLE AND EXCLUSIVE REMEDIES AND TRUE'S ENTIRE LIABILITY FOR ANY BREACH OF THIS LIMITED WARRANTY. TRUE'S

LIABILITY SHALL UNDER NO CIRCUMSTANCES EXCEED THE ACTUAL AMOUNT PAID BY YOU FOR THE PRODUCT, NOR SHALL TRUE UNDER ANY CIRCUMSTANCES BE LIABLE FOR ANY CONSEQUENTIAL, INCIDENTAL, SPECIAL OR PUNITIVE DAMAGES OR LOSSES, WHETHER DIRECT OR INDIRECT. SOME STATES DO NOT ALLOW THE EXCLUSION OR LIMITATION OF INCIDENTAL OR CONSEQUENTIAL DAMAGES, SO THE ABOVE LIMITATION OR EXCLUSION MAY NOT APPLY TO YOU.

NOTE TO AUTHORIZED WARRANTY LABOR PROVIDERS:

Warranty labor reimbursement or warranty parts rights may not be transferred to, reassigned to, a third party without the express written consent of TRUE. Even jobbing out warranty labor requires TRUE's written approval.

TR950 TREADMILL SERIAL NUMBERS:

The TR950 treadmill comes with two serial numbers; one on the base and one on the display console (see diagram below). The serial number on the base is on the lower portion of the treadmill directly adjacent to the power inlet. The console serial number is located on the bottom right side of each console. Please write down your serial numbers below and keep for your records.

CONSOLE SERIAL NUMBER:

BASE SERIAL NUMBER:



SAMPLE SERIAL NUMBER STICKER:



Keep this page for your records

CHAPTER 7: WARRANTY INFORMATION

Thank you for purchasing a TRUE product. To validate the TRUE product warranty the fast and easy way, please go on-line now to truefitness.com and register your product. The information you provide will never be distributed to any other individuals or agencies for any purpose. If you prefer to mail your warranty card, have the owner of the product complete the information below and return it to TRUE Fitness within 30 days from the date of equipment installation.

Please Note: Failure to register this product will result in no servicing or authorization of parts to be shipped.

To mail your warranty information, please fill in the information below and mail to: Service Dept., TRUE Fitness, 865 Hoff Road, St. Louis, MO 63366 (or save postage and register online at www.truefitness.com)

Residential Warranty Registration

**PLEASE PROVIDE BOTH SERIAL NUMBERS BELOW.
REQUIRED FOR WARRANTY REGISTRATION:**

CONSOLE SERIAL NUMBER:

BASE SERIAL NUMBER:

Model Type: Treadmill Elliptical Bike
Other _____
Date of Purchase _____
Purchased From (dealer name) _____
First Name _____
Last Name _____
Address _____
City _____ State _____ ZIP _____
EmailAddress _____
Phone _____

1. Where did you first learn about TRUE?

- a. Dealer b. Website
 c. Referral d. Gym/Club
 e. Current Customer f. Other _____

2. The primary user(s) is:

- a. Male b. Female
 c. Both

3. Do you currently belong to a health club?

- a. Yes b. No

4. Your age group:

- a. Under 25 b. 25-35

- c. 36-45 d. 46-55
 e. 56-65 f. 65 +

5. What was the primary reason you bought a TRUE product? (Check only one)

- a. Design/Appearance b. Dealer
 c. Price d. Ease of Operation
 e. Quality of Construction f. Size
 g. Reputation h. Warranty
 i. Friend/Family Recommendation

6. Do you plan to purchase more fitness equipment in the next 6-12 months:

- a. Yes b. No

7. If you answered "yes" to question 6, what type do you plan to purchase?

- a. Treadmill b. Elliptical
 c. Stationary Bike d. Free Weights
 e. Gym f. Other _____

8. What is your annual household income? (Optional)

- a. under \$50,000
 b. \$50,000 - \$75,000
 c. \$75,000 - \$100,000
 d. \$100,000 - \$150,000
 e. \$150,000 +

9. You are a valued TRUE customer and your suggestions allow us to continually improve your experience. Is there anything else you would like us to know? Please explain: