

Technical Background Dynaudio Ocos

1/10

1 Introduction

From a technical point of view, today's audio equipment operates at an unimaginably high level of performance. Nevertheless, phenomena exist that greatly influence the reproduced sound but cannot be completely explained. For example, knowledgeable audiophiles understand that the best sound quality depends not only on the quality of the components used, but ultimately in finetuning the system as a whole. It is in this fine tuning that the influence of

connecting cables may be as significant as the influence of components. A multitude of speaker cables – from cheap and ordinary zip cord to highly sophisticated super cables – are being offered today. Differences among various cables are clearly audible but reliably producing the desired result proves problematic. These differences are largely compensatory in nature; that is, the source of the problem remains.

2 The Beginnings of Dynaudio Ocos

Many years ago, Dynaudio had already experienced the problem presented by cable-matching within audio systems. It began with the development of a preamplifier that was intended to outperform any previously designed unit. This preamplifier had a bandwidth of more than 1 MHz to avoid any restriction. Independence of cable influences theoretically should have been achieved by an extremely low output impedance. The interconnect cables were suspected of producing a bandwidth limitation, resulting from an interaction between cable capacitance and the output impedance of the preamplifier. To eliminate this influence, a pre-

amp output stage was designed with a very low output impedance approaching zero ohms – similar to the output impedance of a power amplifier. Any sonic influence due to cable variances should have been completely removed under these conditions.

Listening tests, however, showed that this was not the case. Like all preamplifiers, this design was dependent upon the interconnect cables. Tests with various diameters, variations to the mechanical assembly and the use of assorted materials resulted in audible differences. However, these differences seemed to be random and showed no indications of predictability.

2.1 The Influence of Impedance

In searching for predictable, repeatable results, Dynaudio Ocos began experimenting with the preamplifier's output impedance. Figure 1 illustrates the experimental setup.

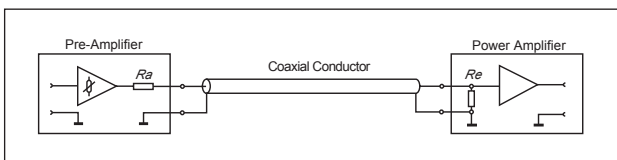

Resistor R_a represents the output impedance of the preamplifier, R_e the input impedance of the power amplifier. These two values can be altered easily to examine the effects. At the time, the typical output impedance of

preamplifiers was about 1k ohm; the input impedance of a power amplifier was about 47k ohms. Testing of the altered preamplifier proved interesting. Surprisingly, the near zero ohm output impedance did not produce the best results. Although sound quality of the modified unit was extremely detailed and offered high resolution, the resulting sound was also unnaturally sharp and hard. A step-by-step increase of the output impedance removed this sharpness; however, at the same time high resolution was lost. An improvement in reproduction quality was achieved by setting the output impedance of the preamplifier and the input impedance of the power amplifier to equal values. The result: high resolution with less brightness.

Technical Background Dynaudio Ocos

2.2 Parallels to Radio Frequency Engineering?

This result reminded Dynaudio Ocos of one of the basic roles of radio frequency engineering: the output impedance of the signal source and the input impedance of the load must be matched to each other. Otherwise, reflections are produced and signal transmission is diminished. In the field of audio engineering, this role has not previously been applied because the methodology for testing the

existence of these reflections has not been developed. Apart from the output impedance of the source and the input impedance of the load, an RF transmission cable must also possess certain properties. It must have a characteristic impedance matched to these impedances. The characteristic impedance is a unique value that can be calculated from the physical parameters of the cable.

2.3 Impedance Matching in the Audio Chain

The concept of impedance matching between preamplifier and power amplifier led to the idea of integrating the cable into this matching procedure. The output impedance of the preamplifier was set to 50 ohms, a highfrequency cable with a characteristic impedance of 50 ohms was

used, and the input impedance of the power amplifier was set to 50 ohms. The sonic result was superior to anything previously heard. Extremely high resolution combined with wonderful musical balance to produce an accurate, faithful reproduction.

2.4 Reproducible Cable Influences

The resulting superior sound quality revealed a clear connection between theory and practice. This correlation between theory and practice could also be reproduced with other amp and preamp combinations. Only one basic condition had to be fulfilled:

$$Z_{\text{source}} = |Z|_{\text{cable}} = Z_{\text{load}}$$

However, the conclusion that the cable's characteristic impedance simply had to be matched to the impedances of the source and the load did not last long. Contrary to expectations, the 50 ohm cables from various manufacturers showed different sonic properties. Therefore, additional factors had to be contributing their effects to the final sound.

3 The Significance of Characteristic Impedance

A basic precept of electrical engineering, the „General Conduction Theory,“ provides the explanation. Physical and mathematical correlations revealed the derivation of characteristic impedance and its application to a transmission system. This theory previously has only been applied to radio frequency engineering. In the field of audio engineering,

these „laws“ have been ignored. Accordingly, the formula for characteristic impedance has been limited to its application in radio frequency engineering, where it is customarily represented in a simplified fashion. Let us now examine characteristic impedance, paying particular attention to the relationships this phenomenon establishes.

Technical Background Dynaudio Ocos

3.1 Calculating Characteristic Impedance

The characteristic impedance can be calculated from the physical parameters of a cable, using a reference length of one meter.

This value is not to be confused with a cable's d.c. resistance.

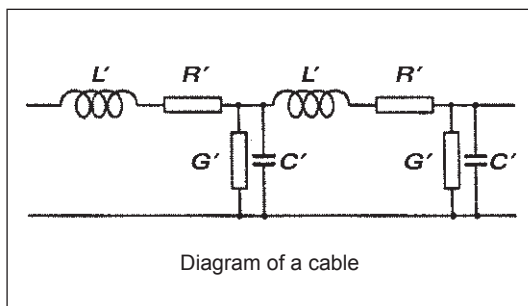

- R' ohmic resistance
- L' inductance
- C' capacitance
- G' conductance of the insulation

For the calculations, conductance G represents the resistance of the insulation. G can be calculated from:

$$G = \frac{1}{R_{\text{Isolation}}}$$

The following formula calculates characteristic impedance. The values are valid for a cable with a length of 1 meter. The characteristic impedance is the characteristic value of a cable and – in a figurative sense – can be compared with a fingerprint.

$$|Z| = \sqrt[4]{\frac{R^2 + 4\pi^2 f^2 L^2}{G^2 + 4\pi^2 f^2 C^2}}$$

|Z| is the amount of the characteristic impedance and is given in ohms.

3.2 The Importance in Radio Frequency Engineering

In radio frequency (RF) engineering some impedance values have become standard values, such as 50, 75, or 300 ohms. Cables with corresponding values are available from many manufacturers and they are compatible with each other.

The characteristic impedance, in this context, refers to high frequencies only, beginning at about 1 Mhz. If the characteristic impedance is not properly matched, reflections will occur which can be measured and calculated.

3.3 Characteristic Impedance Depends Upon Frequency in Audio Engineering

A complete examination of the formula, applied to audible frequencies, produces surprising results: some examples demonstrate that the characteristic impedance depends on the frequency.

The typical values of a cable are:

- R = 0.05 ohms
- L = 0.4 uH (0.0000004 Henry)
- C = 50 pF (0.00000000005 Farad)
- R₁ = 1,000,000,000 ohms, hence
- G = 1/R₁ = 0.000000001 Siemens

Inserting these values into the basic formula for 1 MHz yields the following values:

$$|Z| = \sqrt[4]{\frac{R^2 + 4\pi^2 f^2 L^2}{G^2 + 4\pi^2 f^2 C^2}}$$

- R² = 0.0025
- 4π² f² L² = 631.6547
- G² = 1 x 10⁻¹⁸
- 4π² f² C² = 0.0025

Technical Background Dynaudio Ocos

This example clarifies that with high frequencies, the influence of R and G can be neglected, since the values – with regard to the remaining summands of the equation – are very small and do not have any significant influence on the result. Therefore, the formula can be simplified as follows:

$$|Z| = \sqrt[4]{\frac{4\pi^2 f^2 L^2}{4\pi^2 f^2 C^2}}$$

Now the equation can be reduced once again and the simplified form, which is usually used in RF frequency engineering, remains:

$$|Z| = \sqrt{\frac{L}{C}}$$

Above a certain value, the characteristic impedance is constant. Therefore, this simplification is acceptable for RF frequency engineering and the formula given above is generally used.

Dynaudio Ocos's decisive finding was that the simplified formula may not be used for audio frequencies. The following example will clarify this fact: the characteristic impedance of the cable described above is 390 ohms at 1,000 Hz and 1,248 ohms at 100 Hz!

3.4 The Characteristic Impedance Response

Characteristic impedance is frequency-dependent and varies inversely to frequency – that is, characteristic impedance increases as frequency decreases. Figure 3 shows the typical characteristic impedance response of a normal 50 ohm coaxial cable.

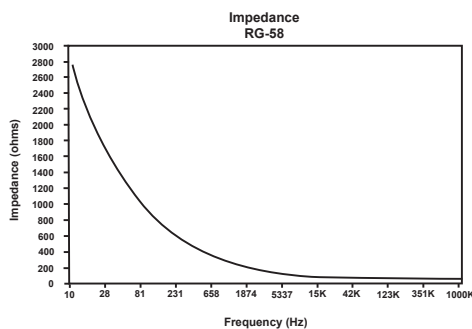

Thus, the increase in characteristic impedance at low frequencies is a physical phenomenon and is independent of cable material and structure. Only the point of ascent, that is, the frequency where the characteristic impedance starts to increase, depends on the structure of the cable.

Our listening tests determined that there is a clear connection between the location of the point of ascent and the audible results. Cables with a characteristic impedance that remain linear over a wide range reproduce sound better and with greater accuracy.

For the first time, the technical parameters and sonic properties of all known cables can be compared to each other, based on their characteristic impedance response.

4 Ocos – Impedance Matching

These new findings led Dynaudio Ocos to attempt an ideal impedance match, based upon the knowledge that the

characteristic impedance depends on the frequency. There are various methods of reaching this goal.

Technical Background Dynaudio Ocos

4.1 Matching of the Source and Load Impedances

For the tests, Dynaudio Ocos used a preamplifier and a power amplifier with an appropriate cable connection. The setup of the test equipment was as shown here:

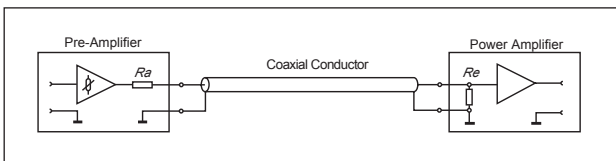

The typical output impedance of a pre-amplifier (R_a) is between 10 and 1,000 ohms; the input impedance of a power amplifier (R_e) at, for instance, 22k ohms. The characteristic impedance of a coaxial cable is between approximately 1,600 and 50 ohms. Figure 4 shows a gross mismatch.

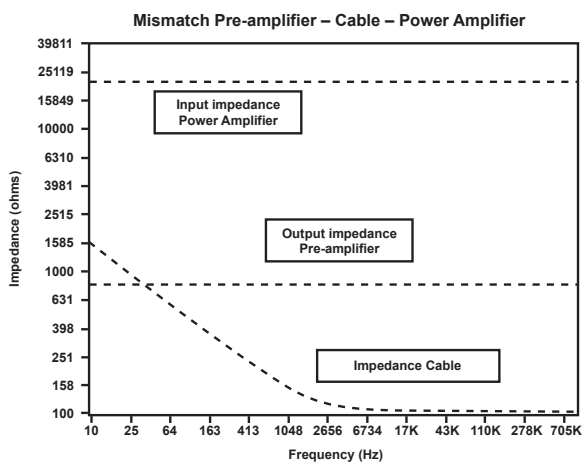

In order to optimally adapt the units to each other, Dynaudio Ocos built a cable that possessed an exactly defined characteristic impedance response with especially narrow tolerances in the audio range. Dynaudio Ocos then developed a matching network with an impedance response corresponding precisely to the cable's characteristic impedance response.

This circuitry now integrated into the preamplifier output gives it a frequency-dependent output impedance that

corresponds to the characteristic impedance of the cable. The same network is switched in parallel to the input of the power amplifier; thus, the input impedance of the power amplifier also depends on the frequency, according to the characteristic impedance of the cable.

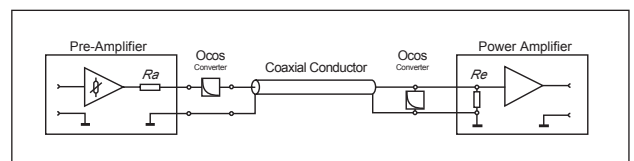

The condition $Z_{source(f)} = Z_{cable(f)} = Z_{load(f)}$ is guaranteed with this method of adaptation.

Although all values vary with frequency, all three values are the same at a certain frequency. In practice, application of these theoretical basics leads to an absolutely reproducible increase in reproduction quality.

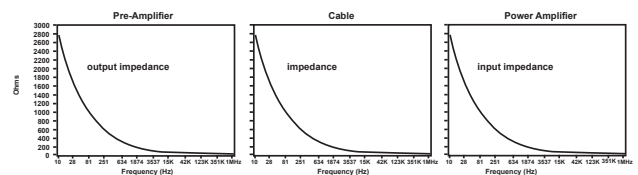

Real world applications of this solution, however, are very limited. This solution demands a defined cable and appropriate equipment. The inputs and outputs of the units must be customized to each other and are therefore not compatible with other units. We can use this solution for only a given combination of units.

Another limitation results from the minimal value of the characteristic impedance of a cable. Existing cables are rarely lower than 50 ohms. However, to produce an match for loudspeakers, we must achieve a value of 4-8 ohms, which is virtually impossible to achieve with conventional cable designs.

Technical Background Dynaudio Ocos

5 Linear Characteristic Impedance

All approaches show that the desired goal of effecting an impedance and characteristic impedance match is correct. However, the fact that the characteristic impedance

is dependent on frequency is a problem that cannot be ignored. So, the basic problem, namely this frequency dependence, must be eliminated.

5.1 Theoretical Basics

As we have seen, the characteristic impedance is constant in the high-frequency range and can be calculated from the formula:

$$|Z| = \sqrt{\frac{L}{C}}$$

For audio frequencies however, the basic formula has to be considered:

$$|Z| = \sqrt[4]{\frac{R^2 + 4\pi^2 f^2 L^2}{G^2 + 4\pi^2 f^2 C^2}}$$

We transform the root by factoring out L^2 and C^2 :

$$|Z| = \sqrt[4]{\frac{L^2 \left(\frac{R^2}{L^2} + 4\pi^2 f^2\right)}{C^2 \left(\frac{G^2}{C^2} + 4\pi^2 f^2\right)}}$$

Now the term can be simplified, the result is:

$$|Z| = \sqrt{\frac{L}{C}} \times \sqrt[4]{\frac{\left(\frac{R^2}{L^2} + 4\pi^2 f^2\right)}{\left(\frac{G^2}{C^2} + 4\pi^2 f^2\right)}}$$

We see that the high-frequency characteristic impedance formula

$$\sqrt{\frac{L}{C}}$$

is multiplied with the factor

$$\sqrt[4]{\frac{\left(\frac{R^2}{L^2} + 4\pi^2 f^2\right)}{\left(\frac{G^2}{C^2} + 4\pi^2 f^2\right)}}$$

in the audio range.

In order to ensure that the characteristic impedance remains the same with audio frequencies too, this factor must be „1.“ Therefore:

$$\left(\frac{R^2}{L^2} + 4\pi^2 f^2\right) = \left(\frac{G^2}{C^2} + 4\pi^2 f^2\right)$$

The frequency-dependent portion $4\pi^2 f^2$ can be subtracted on both sides; hence, it is removed from the equation.

Now calculate the root. What remains is the mathematical solution of the problem:

$$\frac{R}{L} = \frac{G}{C}$$

This formula is the key for correcting the errors present in all conventional cables:

If a cable meets this requirement, the characteristic impedance over the entire audio frequency range no longer depends on the frequency.

Technical Background Dynaudio Ocos

5.1.1 Pupin Conduction

These findings are not new; they are available in specialized literature. These correlations were discovered decades ago, when extremely long telephone lines were laid in the USA. They can also be found in the „General Conduction Theory.“ Great deterioration of speech clarity with extremely long lines results from this problem.

To improve speech clarity, the following approach was put into practice:

In order to fulfill the requirements for a linear characteristic impedance, the value L in this equation was corrected. At certain distances, according to calculations, large coils were integrated into the cable. In practice, this theory was proven by the fact that speech clarity was improved.

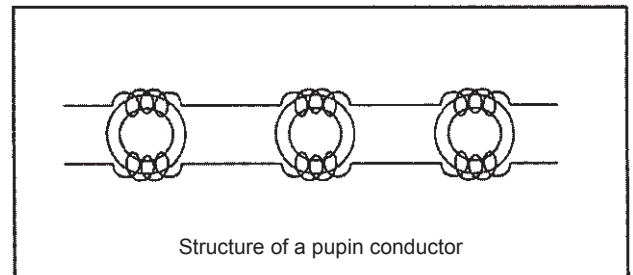

For hi-fi applications, however, this solution is inappropriate because this technique induces limitations.

5.2 Possible Solutions for Audio Frequencies

Since a sufficient alteration of the inductance or the capacitance of a cable will cause high frequency problems, only the values R and G can be modified.

Remember: R represents the wire's resistance; G represents the insulator's resistance.

To achieve a characteristic impedance of about 8 ohms, the value of R/G should be about 64. For this purpose, R must be very small, or G much higher, than in a conventional cable. Small R will lead to a much larger cable diameter. However, to achieve a characteristic impedance of 8 ohms via the diameter, the cross-section would have to be 2 x 500 mm²; this cable would have a diameter of 45 mm (approx. 2.5"/conductor) and would not be practical.

Therefore, only G, the insulation value, remains an influential variable. If the value of G increases, the result will be a lower insulation resistance, i.e. the insulation not only has to insulate (and hence, determine the capacitance) but also to conduct in a defined way. To test this deter-

mination, Dynaudio Ocos inserted resistors between the conductors of a cable, at exact distances, as determined by the above calculations. The resulting sound demonstrated clear improvements in quality.

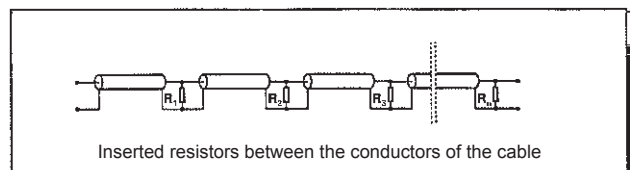

However, this solution is only an approach to the ideal, which improves as the number of resistors increases. Here, we must consider practical restrictions: the more solder junctions and interruptions introduced to the cable, the more the original properties of the cable are lost. Theoretically, infinitely small distances and an infinite number of resistors would be necessary. The above listening tests demonstrate that partial compensation via resistor bridges, properly spaced, leads to reproducibly better results. Unfortunately, this idea is not practical to implement.

Technical Background Dynaudio Ocos

8/10

6 Loudspeaker Cables With Constant Characteristic Impedance

Dynaudio Ocos's goal was to design a cable with a characteristic impedance of about 8 ohms, independent of the frequency. The already described solution (resistors between the conductors) was the starting point. In order to perfect this approach, Ocos began work on a homogeneous solution, that is, balanced and constant distribution of the capacitance and conductivity of the insulation. A completely new type of insulation had to be developed. On one hand, it must insulate reliably and, on the other hand, conduct in a defined way. This task is made difficult because the capacitance is also determined by the insulation. Additionally, the physical cable also influences inductance and resistance, which depend on the insulation.

Clearly, all parameters of the equation are interdependent and are determined by the insulation. Consequently, they cannot be modified individually. This task becomes even more complex because of additional dependencies: All parameters L, C, R and G also depend upon the frequency, temperature, barometric pressure, voltage, and time. Thus, considering the insulation, as well as the design and dimension of the cable, all parameters are clearly interdependent. As you might imagine, such a cable is difficult to manufacture. The Dynaudio Ocos approach is an absolute contradiction to all conventional cables. Previous design efforts rely on the highest insulation resistance possible, and do not acknowledge the dependencies mentioned above.

6.1 Manufacture

Theory shows us the difficulty in manufacturing a cable with these properties. The interdependencies of the physical parameters of a cable with conducting insulation are not well known. Hence, we conducted numerous experiments and tests to determine these functions. In considering the manufacturing process of a cable, the efforts become clear: The copper wire must be drawn and stranded; the mixture of the conducting insulation must be produced; the extruder must be adjusted; the insulation must be injected; after cooling off, the shielding must be braided; and finally, the jacket must be injected. Adjusting all the machines requires a long time. Finally, a cable construction emerges, which is measured, and these results are compared to the computer calculations. Many tests were carried out to ensure a well-balanced design, taking into account the dependencies of the various parameters. These complex production process demands can only be met by a high-tech company.

The Swiss company Huber&Suhner proved to be an ideal partner. This company has a long tradition of manufacturing high-quality cables for high-tech applications (microwave, military-, and EDP-technology). H&S has both the expertise and the production facilities.

After several years of development work and countless tests, a cable with a constant characteristic impedance in the audio range was ready for production. The characteristic impedance was optimized for the range of a loudspeaker's impedance. With this cable, the typical rising characteristic impedance in the lower frequencies did not exist.

For the first time ever, a speaker cable with constant characteristic impedance, independent of frequency fluctuation existed.

Technical Background Dynaudio Ocos

7 Dynaudio Ocos – A Cable With New Dimensions

The following figure shows the development of the characteristic impedance of various loudspeaker cables. These are cables with a diameter of 0.5 mm, 0.75 mm, and 10 mm. The curves show an increase in the characteristic impedance that depends on the diameter. The maximum characteristic impedance approaches 8,000 ohms.

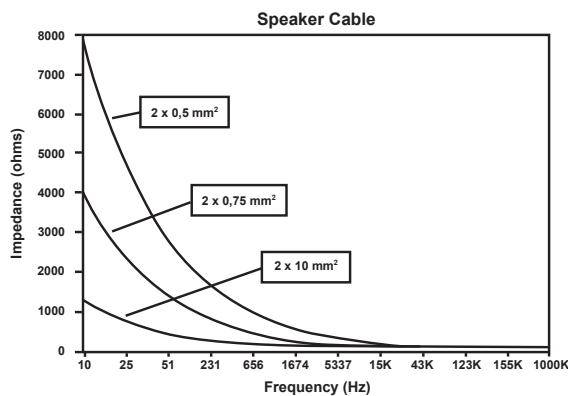

Due to the scale used, the curve of the Dynaudio Ocos cable cannot be resolved in this diagram because it is nearly linear, close to the 0-line. The next figure is an enlargement of this diagram and shows the range up to 400 ohms. Here the Dynaudio Ocos cable clearly differs dramatically from all other cables.

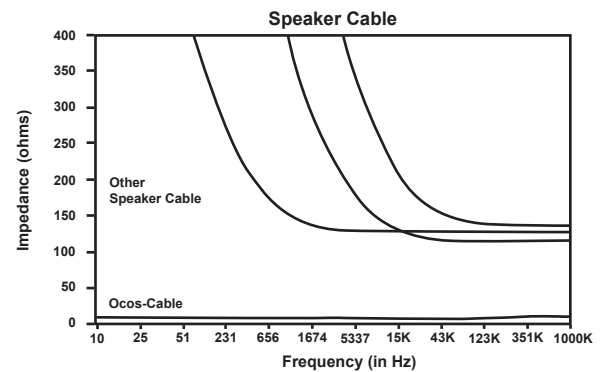

Dynaudio Ocos has succeeded in producing a loudspeaker cable that fulfills the conditions for optimum matching and signal transmission. All prior experience – that thicker cables offer improved performance – coincides with the behavior of characteristic impedance.

However, even the thickest cables imaginable demonstrate this fundamental problem in the lowest frequency range. It is merely the point of ascent that moves further down. Also, using various materials only influences the position of the point of ascent; the basic problem remains.

8 The Design

The following figure clarifies the structure of the Dynaudio Ocos cable.

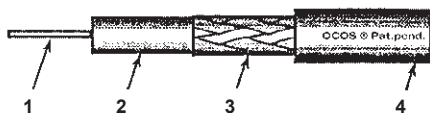

- 1 Center Conductor
- 2 Partially conducting doped insulation
- 3 Outer conductor and shield
- 4 Outer insulation

One appealing aspect of the Dynaudio Ocos design is the fact that its optimum properties are achieved with a diameter of only 6 mm. Therefore, using Dynaudio Ocos cable does not pose any practical problems. The optimization of this cable has another effect: even long cable runs do not show any loss in quality – a common problem with conventional cables. Only with lengths in excess of 100 meters (approximately 330 feet) might the resistance of the insulation cause a level loss. One need not expect any problems with standard lengths.

Technical Background Dynaudio Ocos

10/10

9 Summary

For audio signal transmission between amplifier and loudspeaker, the Dynaudio Ocos cable provides the optimal solution. The cable is neutral in sound and does not influence the sound of reproduction or the characteristics of the recording.

The following advantages can be stated:

- The transmission quality is of the highest possible fidelity.
- Longer speaker cable runs are possible without the usual loss in quality.
- Different cable lengths between the left and right channels do not pose any problems.
- The modest diameter of Dynaudio Ocos cable allows inconspicuous installation.
- The Dynaudio Ocos plug and socket system helps avoid short circuits and incorrect polarity.