

MAKE MOVIES WITH YOUR MAC!

A P R I L 2 0 0 0

# Macworld

MACINTOSH® AUTHORITY  
[www.macworld.com](http://www.macworld.com)



Get the Picture  
with a FireWire-  
Equipped Digital  
Camcorder, page 81

Put It All  
Together with  
Apple's Easy-to-Use  
iMovie, page 74

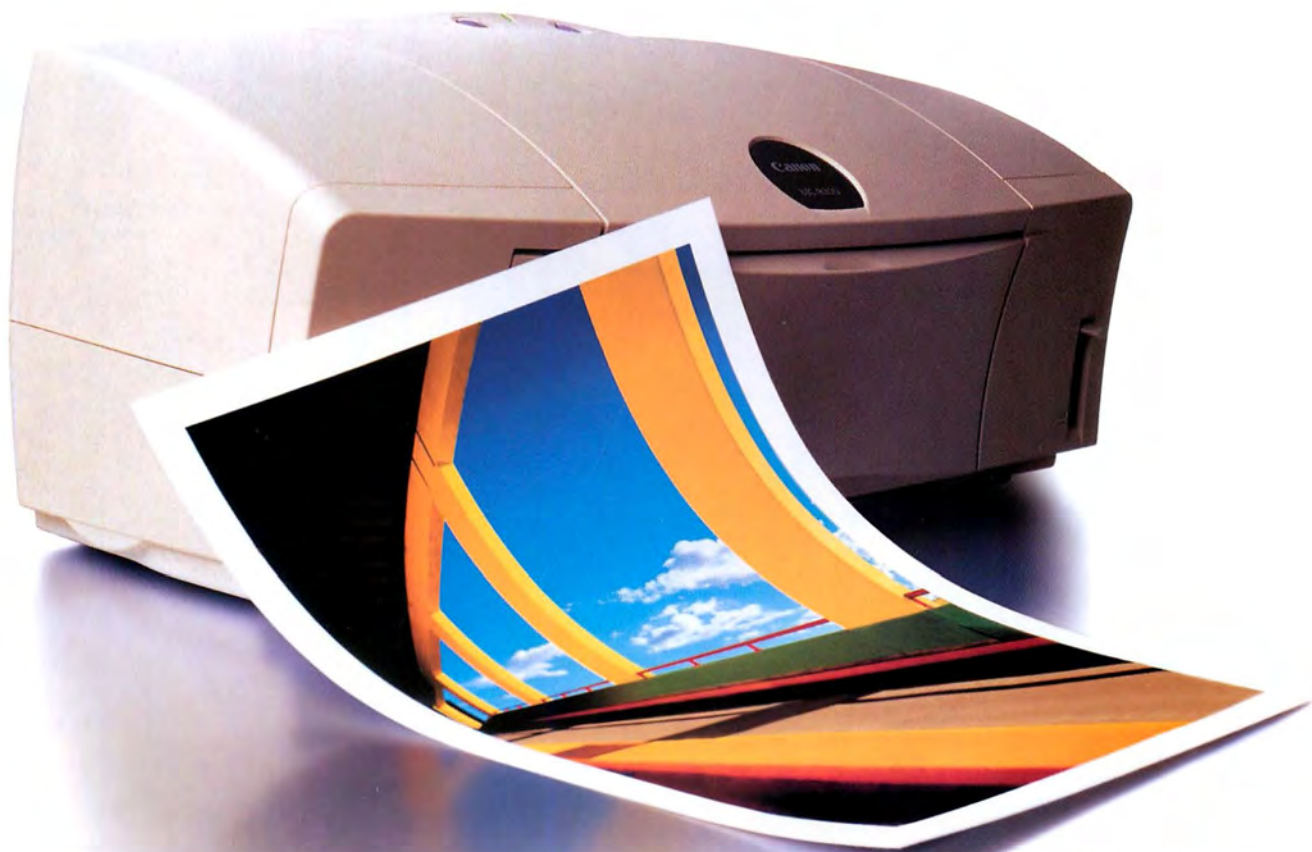

*The Canon  
BJC-8200 Color Bubble Jet  
Photo Printer*

### **Photos in Minutes**

*No more trips to the photo lab for enlargements.  
The BJC-8200 delivers professional-quality  
8" x 10" photographs in approximately three minutes.\**

### **Picture-Perfect Quality**

*1,536 nozzles apply microfine ink drops just  
4 picoliters in size to create  
unprecedented tonal scale and complex detail.*



# Unlike our competitors, this is not the first device we've made for photographers.

Introducing our latest innovation for photographers: The BJC-8200 Color Bubble Jet™ Photo Printer with 1200 x 1200 dpi resolution. Combining Canon's exclusive MicroFine Droplet Technology™ with a 1,536-nozzle printhead, the BJC-8200 gives you the freedom to print professional-quality 8" x 10" prints at your leisure. In approximately three minutes.\* And using Canon Photo Paper Pro in concert with our six-color ink system, you'll get rich, glossy output that rivals the results of photo labs. In other words, we've just brought the darkroom to your desktop.

The perfect solution for any photography enthusiast, the BJC-8200 is compatible with both Mac® and PC computers. But most important, it's the only photo printer from a company that knows a thing or two about photography. For more information, visit our Web site at [www.BJC8200.com](http://www.BJC8200.com) or call 1-800-OK-CANON.

**Canon** KNOW HOW™

## **1200 x 1200 Resolution**

*The BJC-8200's razor-sharp 1200 x 1200 dpi resolution is nearly 40% higher than ink jet printers with 1440 x 720 dpi.*

## **Ultimate Value**

*With the Canon Think Tank System,\*\* you'll save money for years to come by replacing ink tanks individually, instead of wasting the entire cartridge.*

# What Canon engineers have to say about the CanoScan® FB 1200S scanner:

Technically speaking, the CanoScan FB 1200S owes its ultra-high resolution to an advance in scanning technology called VAROS™ (Variable Refraction Optical System). With VAROS, the FB 1200S achieves true optical 1200 x 1200 dpi resolution in a compact, desktop size and at a breakthrough price.

The technology involves two passes. On the first pass, the FB 1200S captures data at 600 dpi. On the second pass, VAROS refracts the optical path by half a pixel. Next, a synthesis of both passes is made, resulting in brilliant tones, real 36-bit color depth, and sharp, vivid, real 1200 x 1200 dpi scans.

To capture subtle differences in tone gradation, the FB 1200S has a high 3.3 density range. And a dual-platform SCSI interface card is included for the quick



transfer of large files. To interface with Canon, call 1-800-OK-CANON or log on at [www.canoscan.com](http://www.canoscan.com).

**Canon** KNOW HOW™

*The CanoScan FB 1200S  
Color Flatbed Scanner*

## Stunning Resolution

*Canon's exclusive VAROS technology delivers true optical 1200 x 1200 dpi resolution.*

## Dynamic Color

*The CanoScan FB 1200S achieves real 36-bit color depth for a superior dynamic range of 3.3.*



## What the critics are saying:

“

*...the best flatbed scanner I've used.\**

~ Jim Seymour, PC Magazine 9/21/99

”

### One Touch Convenience

*One button gives you instant access to software.  
Just press it and the program of your choice is launched.*

### Performance Software

*ScanGear™, Adobe® Photoshop® 5.0 LE and Textbridge®  
are all included free of charge for Mac® and PC.\*\**

# Macworld

Incorporating MacUser



Create killer movies from your desktop, page 72.

## Features

### Cover Story

- 72 Who Needs Hollywood?**  
It's never been easier to create movies on your Mac!
- 74 Home-Movie Magic**  
BY JIM HEID Expert video tips and tricks help you get the most out of Apple's easy-to-use iMovie.
- LAB TEST**
- 81 Camcorder Casting Call**  
BY BEN LONG Looking for a digital video camera? We took five affordable FireWire-based camcorders for a location shoot.

- 86 E-mail for Everyone**  
BY ADAM C. ENGST Why settle for just any old e-mail program? Check out *Macworld's* e-mail guide, and find the right software for the unique way *you* correspond.

#### ON THE COVER

Photograph by Mark Johann

## Create

- Graphics**
- 97 Sharper Images in Photoshop**  
BY DAVID BLATNER Get back the sharpness that you inevitably lose whenever you scan an image.
- Graphics**
- 101 Real-World Blends**  
BY DEKE MCCLELLAND Adobe Illustrator 8 gives you more power than ever before to add realistic-looking color transitions in your images.
- Web**
- 105 Zap Common Browser Bugs**  
BY LISA SCHMEISER Don't let browsers ruin your carefully designed Web pages; write HTML that outsmarts them.



It's time for Apple's naysayers to eat crow, page 176.





Master your blends  
in *Illustrator 8*, page 101.

## News

### 27 Is Apple Going All Out Online?

With its Internet strategy, Apple seems to be positioning itself as a content provider.

### 28 Macromedia Designs Product Upgrades

New versions of FreeHand and Director look to streamline the design process.

### 28 Creative Makes Noise with Mac Products

Sound Blaster Live sound cards will hit the Macintosh market later this year.



Apple G4s pack a punch,  
page 38.

## Opinion

### 19 Letters

#### 25 The Vision Thing

BY ANDREW GORE When it comes to desktop moviemaking, a little knowledge is a dangerous thing.

#### 69 The Game Room

BY CHRISTOPHER BREEN Transform your Mac into a killer gaming machine.

#### 176 The Desktop Critic

BY DAVID POGUE It's payback time. Revisiting the so-called experts who predicted Apple's demise.

### 12 How to Contact Macworld



Capture the moment with  
one-megapixel cameras, page 44.

## Secrets

#### 93 The Desktop Multiplex

BY JOSEPH SCHORR Handy shortcuts and hidden features of Apple's QuickTime Player.

#### 95 Quick Tips

BY LON POOLE Tips, tricks, and shortcuts.

## Reviews

- 34 ★★★★★ Dreamweaver 3  
Web authoring software
- 36 ★★★★ Fireworks 3  
Web-graphics editor
- 38 ★★★★ Apple Power Macintosh G4/350;  
★★★★ Apple Power Macintosh G4/450  
Professional systems
- 40 ★★★★½ Kiplinger TaxCut '99 Deluxe  
Filing Edition;  
★★★★½ Quicken MacInTax Deluxe '99  
Tax-preparation software
- 42 ★★★★ Epson Stylus Color 760;  
★★★★½ Epson Stylus Color 860  
Color ink-jet printers
- 44 ★★★ Epson PhotoPC 650;  
★★★★ Olympus D-450 Zoom  
One-megapixel digital cameras
- 46 ★★★★½ Newer Maxpower G4 400MHz;  
★★★★½ XLR8 Mach Speed G4z 400MHz  
G4 ZIF socket upgrades
- 48 ★★★★½ FontAgent 8;  
★★★★½ Font Reserve 2.5  
Font utilities
- 50 ★★★★ Kai's Power Tools 6  
Adobe Photoshop plug-ins
- 52 ★★★ Norton AntiVirus 6.0.1  
Antivirus utility
- 54 ★★½ CD-ROM ToolKit 4.0.1;  
★★★★½ CD-ROM SpeedTools 4.1  
CD-ROM utilities
- 56 ★★★ Linksys EtherFast 10/100 Instant  
GigaDrive;  
★★★★½ Quantum Snap Server 2000  
Network storage devices
- 58 ★★★★★ QuickKeys 4.0  
Keyboard macro utility
- 58 ★★★★ Stuffit Deluxe 5.5  
File-compression utility
- 60 ★★★ Thinking Home 1.0.3  
Home-automation software
- 62 ★★★★½ Papyrus 8.0.5  
Bibliographic reference software
- 64 ★★½ MacWasher 1.0.2  
Security utility
- 66 ★★★ Descent 3  
3-D shooter game



**WE'VE REMOVED THE BIGGEST OBSTACLE  
BETWEEN YOU AND A PRINTER. THE STORE.**



“Visit our crowded facility! Stand on lines! Interact with indifferent, under-trained clerks! And remember, with every purchase you help us pay our overhead!”

No, we don't blame stores for not being this, well, forthcoming. They have a business to run. But do you really want to help them run it?

At The Virtual Printer Store, we bring you the printer without the inconvenience of the store.

You shop at home or office, via phone or mouse. You don't have to deal with traffic – street, store or otherwise. You only pay for what you need (the printer) instead of what you don't (bricks, mortar and middlemen). And since you buy direct from the manufacturer, you deal with people who'll actually talk to you after the sale.

We offer unlimited technical support 24 hours a day, 7 days a week – for the entirety of the one-year warranty. And if you run up against a problem we can't solve, our Platinum Exchange Warranty Program guarantees you a replacement printer by the next business day. (All our printers come with a thirty-day, money-back guarantee as well.)

Finally, we offer printers good enough to sell themselves – because they have to. Printers that turn out vivid halftones, poster-sized graphics, printshop-quality text, and perform various other noteworthy feats noted below.

The Virtual Printer Store. Because the best place to shop for a printer isn't a shop at all.



### ELITE 12 N Series

12 pages per minute  
600 x 600 dpi resolution  
Maximum Print Area 8.5" x 14"  
Letter, legal, envelope  
250-sheet Universal Tray  
PostScript® Level 2 compatible, PCL 5  
35 PostScript fonts, 15 PCL fonts,  
45 downloadable fonts  
RAM expandable to 64 MB  
1st year Platinum Exchange  
EtherTalk® TCP/IP  
USB, Ethernet (10 BaseT),  
Bi-directional Parallel

2nd Paper Feeder<sup>1</sup>  
(includes 500-sheet Universal Tray) Add \$299

2nd year Platinum Exchange<sup>1</sup> Add \$ 99

**\$849**

Also available in LocalTalk® version

**\$949**

1200 dpi version



### ELITE XL 20 Series

20 pages per minute  
600 x 600 dpi resolution  
Maximum Print Area 12.6" x 35.1"  
Letter, tabloid, legal, envelope, poster  
500-sheet Universal Tray  
PostScript Level 2 compatible, PCL 5  
35 PostScript fonts, 15 PCL fonts,  
250 downloadable fonts  
RAM expandable to 64 MB  
1st year Platinum Exchange  
EtherTalk, LocalTalk, TCP/IP  
Ethernet (10 BaseT, AAUI),  
Bi-directional Parallel

2nd or 3rd Paper Feeder<sup>2</sup>  
(includes 500-sheet Universal Tray) Add \$329

2nd year Platinum Exchange<sup>1</sup> Add \$179

**\$1599**

Lease \$56 Month/36 months<sup>4</sup>

**\$1899**

800 dpi version  
Lease \$67 Month/36 months<sup>4</sup>

**\$2199**

1200 dpi version  
Lease \$77 Month/36 months<sup>4</sup>



### ELITE 12/600 USB

12 pages per minute  
600 x 600 dpi resolution  
Maximum Print Area 8.5" x 14"  
Letter, legal, envelope  
250-sheet Universal Tray  
PostScript Level 2 compatible, PCL 5  
35 PostScript fonts, 15 PCL fonts,  
45 downloadable fonts  
RAM expandable to 64 MB  
1st year Platinum Exchange  
USB (cable included),  
Bi-directional Parallel

2nd Paper Feeder<sup>1</sup>  
(includes 500-sheet Universal Tray) Add \$299

2nd year Platinum Exchange<sup>1</sup> Add \$ 99

**\$799**



**TO ORDER CALL 1.800.422.7777 OR VISIT WWW.THEVIRTUALPRINTERSTORE.COM**

Circle 43 on card or [www.macworld.com/getinfo](http://www.macworld.com/getinfo)



**THE VIRTUAL PRINTER STORE™**



Supports one additional paper feeder. <sup>2</sup>Supports two additional paper feeders. <sup>3</sup>Platinum Exchange pricing is at point of purchase only. <sup>4</sup>Leasing provided by independent leasing companies to qualified customers. Lease payments based on 36-month terms. Lease terms subject to change without notice or obligation. <sup>5</sup>All GCC printers are Mac OS compatible. Windows certification is for the 20 Series printers only. GCC Technologies is a registered trademark of GCC Technologies, Inc. Elite and The Virtual Printer Store are trademarks of GCC Technologies, Inc. All other trademarks or registered trademarks are trademarks of their respective companies. Pricing and specifications valid only in the U.S. (110V printers) and subject to change without notice. For international orders, please contact local distributors. ©2000 GCC Technologies.

Keycode 004MWD2



# Conquer Disk Damage



Introducing DiskWarrior™,  
a revolutionary new way  
to restore damaged disks!

DiskWarrior is a revolutionary new utility that combats disk damage. It quickly rebuilds, recovers and optimizes your HFS and HFS Plus disk directories, eliminating all directory errors and recovering lost files. Other utilities attempt to repair disks by patching the damage. Patching can result in more damage and permanent loss of files.

## 100% Recovery Assurance

Only DiskWarrior builds a new optimized directory using data recovered from the damaged directory. You have 100% assurance that DiskWarrior will always restore your disks and recover your files when directory damage is your enemy.\* You'll also have 100% confidence that you're getting the desired results. DiskWarrior's exclusive Preview ability lets you preview the restoration. You can examine your damaged disk in the Finder as it will appear after the directory is restored but before any changes are made to your disk.

## Routine Maintenance

DiskWarrior is your first line of defense against unseen disk damage. Running DiskWarrior regularly prevents small unseen problems from becoming large ones by keeping your directories error free. You'll also keep your directories optimized to speed up overall disk performance.

©1998 Alsoft, Inc. PO Box 927, Spring, Texas 77383-0927 USA. 281-353-4090 or fax 281-353-9868. DiskWarrior is a trademark of Alsoft, Inc. \*Visit our web site or call for requirements. DiskWarrior is not a magician. No utility can restore directories that have been written over.



THE UTILITY COMPANY

**ALSOFT**

[www.alsoft.com](http://www.alsoft.com) 800-257-6391

Circle 140 on card or go to [www.macworld.com/getinfo](http://www.macworld.com/getinfo)

# Macworld

VP OF CONTENT/EDITOR IN CHIEF	Andrew Gore
EDITOR	Michael Penwarden
EDITOR, MACWORLD.COM	Jason Snell
SENIOR EDITOR, DEPARTMENTS	Nancy Peterson
SENIOR EDITOR, FEATURES	Scholle Sawyer
SENIOR EDITOR, PRODUCTS	Stephen Beale
SENIOR EDITOR, REVIEWS	Linda Comer
SENIOR EDITOR, MACBUY.COM	Suzanne Courteau
SENIOR EDITOR, MACWORLD.COM	Lisa Schmeiser
ASSOCIATE EDITORS	Philip Michaels, Terri Stone
ASSISTANT EDITORS	Frith Breitzer, Brett Larson, Kathryn Lunsford, Jonathan Seff
EDITORIAL ASSISTANT	David Read

## CONTRIBUTING EDITORS

Henry Bortman, Christopher Breen, Bruce Fraser, Jim Heid, Ted Landau, Deke McClelland, Rik Myslewski, Tom Negrino, David Pogue, Lon Poole, Stephan Somogyi, Franklin N. Tessler

## LAB

LAB DIRECTOR	Kristina De Nike
SENIOR LAB ANALYSTS	Jeffy K. Milstead, Kevin Mitchell
LAB ANALYST	Gil Loyola
INVENTORY COORDINATOR	Ulyssis Bravo

## COPY EDIT

MANAGING EDITOR	Claire H. Breen
ASSISTANT MANAGING EDITOR	Paul-Michael King
COPY CHIEF	Jon Zobenica
COPY EDITOR	Charles Purdy

## ART AND DESIGN

DESIGN DIRECTOR	Eleanor Leishman
ART DIRECTOR	Sylvia Chevrier
ASSOCIATE DESIGNERS	Jackie Goodman, Jonathan Woolson
DESIGN ASSOCIATE	Sean McDonald

## INTERNATIONAL EDITORS

Steven Noble, Australia; Bernard Le Du, France; Andreas Borchert, Germany; Enrico Lotti, Italy; Yoshio Moriya, Japan; Tomasz Bitner, Poland; Daniel de Blas, Spain; Nils Holmlöv, Sweden; Anderson Huang, Taiwan; Bahattin Apak, Turkey; Simon Jary, United Kingdom





My corporate phone and e-mail lists; that cozy little bistro in Milan.



Meet with sales team, 10:30 am; Asia/Pacific conference call, 5:00 pm.



Notes for FY 2001 global forecasts; my yoga relaxation exercises.



Download Q4 sales figures; get tennis racquet re-strung.



Synchronize and back up my Palm Vx™ handheld with my Mac.  
With just one touch.

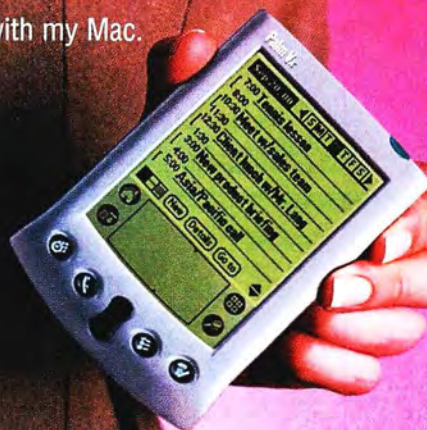

Amanda Johnson  
VP, Worldwide Sales

# Simply Palm.

[www.palm.com](http://www.palm.com)

Palm, Inc.  
PalmConnect™ kit required for Macintosh connectivity, sold separately. ©2000 Palm, Inc. All rights reserved. PalmConnect and HotSync are registered trademarks and Palm, Palm Vx, Simply Palm and the HotSync and Palm logos are trademarks of Palm, Inc. or its subsidiaries.



Project Scheduling Made Easy!

# DON'T TELL MY BOSS

**NEW**  
**Version 6.03**

- ExpressDate™ • FastSteps™
- Open/Export MS Project MPX files
- Full AppleScript Support
- Histograms • Hyperlinks
- and more!

I'm not a project management expert, but everyone thinks I am. Most of my time is spent completing tasks, so I need a scheduling tool that's easy, fast, and flexible.

FastTrack Schedule 6.03 fills the bill. It keeps me organized and in control displaying all my project details in rich, colorful timelines. FastTrack Schedule provides

just the right amount of power because it's more sophisticated than day-planners, but *easier*

*to use and half the price of traditional, high-end project managers.*

**\$199\***

The presentation-quality schedules clearly illustrate project objectives and deadlines keeping team members and clients informed and up-to-date. In a single schedule, I can outline multiple projects, make assignments, track cash flows, set-up dependencies—even add graphics.

Whether I use it once a week or every day, FastTrack Schedule makes project scheduling easy.

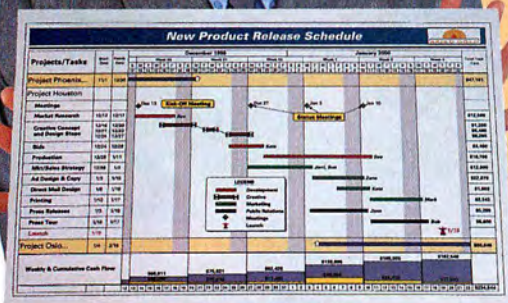

**TRY IT & BUY IT!**

Download the demo and order online today at [www.aecsoft.com](http://www.aecsoft.com).

# FastTrack Schedule™

Version 6.03

**AEC**  
SOFTWARE

**ON YOUR DESKTOP,  
OR ON THE GO!**

Now you can view and edit schedules anytime, anywhere.

**Preview the Palm Version at [www.aecsoft.com](http://www.aecsoft.com)**

Circle 83 on card or go to [www.macworld.com/getinfo](http://www.macworld.com/getinfo)

# Macworld

PRESIDENT AND CEO	Colin Crawford
ASSISTANT TO THE CEO/OFFICE MANAGER	Elizabeth Lilly
VP/CHIEF FINANCIAL OFFICER	Stephen Daniels
BUSINESS MANAGER	Eos de Feminis
ACCOUNTING COORDINATOR	Ronda Bittner
BILLING MANAGER	Ricardo Sandoval
DIRECTOR OF HUMAN RESOURCES	Sue Murphy
HUMAN RESOURCE MANAGER	Marisa Chow
IT MANAGER	Michael Talbot

## DISPLAY ADVERTISING SALES

VP OF SALES/PUBLISHER	Steve Plevin (415/243-3509)
ASSOCIATE PUBLISHER, EAST	Cynthia Ramsey (973/243-1197)
NATIONAL SALES DIRECTOR	Liz Pabón (415/243-3526)
SALES & MARKETING COORDINATOR	Laura Ross (415/243-3642)
SALES ASSISTANT	Katherine Lebioda (415/243-3577)
SALES ASSISTANT	Brock Keeling (415/243-3662)
NATIONAL ACCOUNTS MANAGER	Jessica Ross (415/243-3583)
ACCOUNT EXECUTIVE	Coretta Wright (415/243-3615)
NATIONAL ACCOUNTS MANAGER	Sara Culley (970/327-4499)
ACCOUNT EXECUTIVE	Margaret Level Green (415/243-3582)
NATIONAL ACCOUNTS MANAGER	Paul Bonarrigo (508/533-4020)
ACCOUNT EXECUTIVE	Jo Zottarelli (631/277-4134)
SHOPPER ACCOUNT MANAGER	Niki Stranz (415/243-3664)
SHOPPER ACCOUNT MANAGER	Carol Johnstone (415/243-3691)
SHOPPER ADMINISTRATIVE ASSISTANT	Alissa Mach (415/243-3628)

## MARKETING

MARCOMM MANAGER	Sharon Sanderson
ONLINE MARKETING MANAGER	Savraj Benedict
MARKETING EVENTS COORDINATOR	Tara James

## PRODUCTION

PRODUCTION DIRECTOR	Cynthia Neustadt
DIGITAL AD COORDINATOR	Alan Anzalone

Macworld is a publication of Mac Publishing, L.L.C. Macworld is an independent journal not affiliated with Apple Computer, Inc. Macworld, MacUser, MacWeek, Macworld Interactive, Macworld Shopper, MW, MW Lab, MW Shopper, The Desktop Critic, Expert Graphics, Quick Tips, Star Ratings, Buyers' Tools, Streetwise Shopper, and Conspicuous Consumer are registered trademarks of Mac Publishing, L.L.C. Apple, the Apple logo, Mac, and Macintosh are registered trademarks, and MacLetter and PowerBook are trademarks, of Apple Computer, Inc. Printed in the United States of America. Copyright © 2000 Mac Publishing, L.L.C. All rights reserved.

© 2000 AEC Software Inc. All rights reserved. Corporate names and trademarks stated herein are the property of their respective owners. \*Estimated Street Price is \$199, prices may vary at individual retailers. Outside the United States, please call (703) 550-1880 for information.





see things differently.



Presenting the head-turning digital video camera – the Kritter<sup>®</sup>USB.

By utilizing isochronous transfer technology (really fast), delivering 320 x 240 (CIF) at 30 fields-per-second (really smooth), the Kritter<sup>®</sup>USB provides the highest-quality video possible in the USB environment. This means a bigger picture, better color and lots of second looks. For more information and complete specifications, visit us at [www.irez.com/yea](http://www.irez.com/yea) or call 1-480-922-0044.



Closes up / Sets up on flat surfaces / Optional wand and base assembly

©2000 PAR Technologies, Inc. All trademarks are the property of their respective owners.

Circle 143 on card or go to [www.macworld.com/getinfo](http://www.macworld.com/getinfo)

**IREZ<sup>™</sup>**  
Looking beyond the beyond...





## FireWire or USB Hard Drives Ready...Set...Go!

**Ready!** Boost your storage capacity by 6 Gigs with PowerHD from TechWorks! Complete with a FireWire or USB cable, AC adapter, manual and Disk Drive TuneUp Special Edition, it's "hot-pluggable", making it READY to use out of the box.

**Set!** The PowerHD is available in the complete set of 5 iMac flavors. Mix or match a FireWire model with your iMac DV or G4, or try a USB model with your iBook or iMac.

**Go!** PowerHD is super portable. The total weight, including the AC adapter, is less than one pound! Just pick it up and GO!

PowerHD – a simple solution for adding hard disk drive space to your Mac. Give us a call at **800.434.4032**, or visit us online at [www.techworks.com](http://www.techworks.com) to order one today!

**Why wait? Just plug & play!**



*Power To Perform™*

© TechWorks is a registered trademark of TechWorks (Delaware) Inc. All other names are registered trademarks of their respective companies.



# Macworld

## HOW TO CONTACT MACWORLD

### Subscription Services

Phone 800/627-2247 or  
303/665-8930, North America only  
303/604-7445, outside North America  
U.S. Mail Macworld Subscription Services  
P.O. Box 54529, Boulder, CO 80322-4529  
World Wide Web [www.zdnet.com/zdsubs/macworld/service](http://www.zdnet.com/zdsubs/macworld/service)

### Subscription Rates

The one-year (12-issue) subscription rate is \$34.97 in the United States and \$54.97 for all other countries (send \$104.97 for air mail). The rate for a one-year (12-issue) subscription with the monthly CD-ROM is \$49.97 in the United States and \$69.97 for all other countries (air mail not available at this time). Checks must be made payable in U.S. currency to Macworld. Please allow 6 to 8 weeks to receive your first issue.

### Back Issues of Macworld

Back issues (subject to availability) are \$8 per issue for U.S. delivery (\$12 outside the United States); prepayment in U.S. currency to Macworld is required. Send check or money order to Back Issues Department, Ziff-Davis Inc., P.O. Box 53131, Boulder, CO 80322-3131.

### Reprints and Permissions

You must have permission before reproducing any material from Macworld. Write to Macworld, Reprints and Permissions, 301 Howard St., 16th Fl., San Francisco, CA 94105; include a phone number. To order reprints of your company's editorial coverage, call Reprint Management Services at 717/399-1900; fax 717/399-8900; e-mail [sales@rmsreprints.com](mailto:sales@rmsreprints.com).

### Mailing Lists

We periodically make lists of our customers available to mailers of goods and services that may interest you. If you do not wish to receive such mailings, please write to us and include a copy of your mailing label.

### Macworld on Microfilm

Macworld is available on microfilm and microfiche from UMI, 300 N. Zeeb Rd., Ann Arbor, MI 48106-1346; 734/761-4700.

### Macworld Editorial

The editors of Macworld welcome your tips, compliments, or complaints. Stories and product reviews from past issues can be located at [www.macworld.com](http://www.macworld.com). We are unfortunately unable to look up stories from past issues; recommend products; or diagnose your Macintosh problems by phone, e-mail, or fax. Contact Apple toll-free at 800/538-9696, ext. 500, for information on user groups in your area.

Our offices are located at 301 Howard St., 16th Fl., San Francisco, CA 94105; 415/243-0505, fax 415/442-0766.

**LETTERS TO THE EDITOR** Direct all comments and suggestions regarding any aspect of the magazine to [letters@macworld.com](mailto:letters@macworld.com). Due to the high volume of mail received, we can't respond personally to each letter. We reserve the right to edit all submissions. All letters published in Macworld or Macworld Online become the property of Macworld.

**QUICK TIPS** Send your questions or tips on how to use Mac computers, peripherals, or software to Macworld, Quick Tips, 301 Howard St., 16th Fl., San Francisco, CA 94105; fax 415/442-0766; e-mail [quicktips@macworld.com](mailto:quicktips@macworld.com). Please include your name, address, and telephone number.



Circle 129 on card or [www.macworld.com/getinfo](http://www.macworld.com/getinfo)



# What's your sign?

VST makes peripherals compatible with your computing wants and needs. Whether your computer is FireWire® or USB based, we offer products that perform well *and* look good.

Our FireWire® Hard Drives and Zip® Drives as well as our USB Hard Drives and Floppy Drives offer such benefits as high-speed data transfer rates, flexible connectivity, easy transportability and hot-swappable capabilities.

Visit our web site at [www.vsttech.com](http://www.vsttech.com) to get more information on these and other products from VST.



## VST

125 Nagog Park, Acton, MA 01720  
[www.vsttech.com](http://www.vsttech.com) ■ (978)263-9700



lomega, the lomega logo, Zip, and The Capacity To Do More, are trademarks of lomega Corporation. All other trademarks are property of their respective holders. lomega patents protected by patent applications pending in the US and other countries. Apple, Mac, Macintosh, the Mac OS logo, PowerBook, and iBook are registered trademarks of Apple Computer, Inc.

# The world's largest PC makers buy our memory direct.

[ *Cut out the middleman.* ]

Buy your memory direct from one of the largest memory manufacturers in the world. Performance, reliability, selection & factory direct savings — **Crucial Technology**, a Division of Micron.

## Crucial is your source for Macintosh memory.

Receive a 10% discount for ordering online. You can't get this quality for a lower price, anywhere.

Upgrades for popular Macintosh models such as:  
iMac, Power Mac G3, iBook, and Power Mac G4.

**64 MB**  
**\$78<sup>29</sup>**  
As low as...

video cards - scanners - motherboards - digital cameras



**More PC upgrades.  
From the memory experts.**

monitors - printers - processors - hard drives - more!!

[www.crucialupgrades.com](http://www.crucialupgrades.com)

Crucial prices reflect an automatic 10% discount for ordering online.

Prices were accurate as of 1/24/00, however, they can (and do) change daily.

©2000 Micron Semiconductor Products, Inc. All rights reserved. Crucial Technology and the Crucial logo are trademarks of Micron Technology Inc., and Micron is a registered trademark of Micron Technology, Inc. All other brands and names used herein are the property of their respective owners. Crucial Technology is a Division of Micron Semiconductor Products, Inc. Phone 208-363-5500. Fax 208-363-5501. E-mail [crucial.sales@micron.com](mailto:crucial.sales@micron.com). Crucial Technology is not responsible for omissions or errors in typography or photography.

Online discounts for over 32,000 upgrades at:

**[www.crucial.com](http://www.crucial.com)**

or call toll free 1-888-363-3082





**The memory experts.**

**crucial**<sup>™</sup>  
TECHNOLOGY  
A Division of Micron<sup>®</sup>





WITH ORDINARY  
PRINTERS,  
YOU SEE THE  
FLOWERS  
BLOOMING.

WITH OUR  
PRINTERS,  
YOU SEE  
THE LADIES  
DANCING.



YOU'VE GOT TO SEE IT IN

**EPSON**

COLOR.



Anyone can show you the flowers. But the textile company that created this catalogue cover wanted to show you more. Like the incredible fabrics worn by the 38 women you see here. Sheer enough to pass for petals. In a palette only nature could imagine. So what did they choose to capture all this color and detail? An Epson printer. The only one they could trust to separate the beauties from the blossoms. Which, when it comes to printers, is what separates the men from the boys.

THE ONLY PRINTERS WITH EVERYTHING YOU NEED FOR ALL THE DETAIL YOU WANT.

To capture the world's most brilliant images, only Epson® color ink jet printers have the PerfectPicture® Imaging System for: 1440 x 720 dpi • Micro Piezo™ technology, for a cleaner, smaller droplet – as small as 3 picoliters • Fast print speeds – up to 12 PPM black/10 PPM color • Quick-drying inks • PC/Mac/USB compatibility. And remember, only Epson supplies guarantee Epson quality. For more information, call 1-800-GO-EPSON or visit [www.epson.com](http://www.epson.com).



Epson Stylus Color Ink Jet Printers.  
Sheer brilliance starting at \$99.\*

\* \$99 on the EPSON Stylus Color 660 after a \$30 mail-in rebate. Up to 12 PPM black/10 PPM color with the EPSON Stylus Color 900. Price may vary. Epson, EPSON Stylus and Micro Piezo are trademarks/registered trademarks of Seiko Epson Corp. PerfectPicture is a registered trademark of Epson America, Inc. ©1999 Epson America, Inc.

Circle 61 on card or go to [www.macworld.com/getinfo](http://www.macworld.com/getinfo)



# Job Opportunities

**Flash 4 Designer • Dallas** • Company on the leading edge of the online training and web development industries is looking for an artistically and technologically creative, self-motivated designer who is a quick learner and fast worker. Qualifications include expertise in Flash 3 and Flash 4, Fireworks 2, Photoshop, Illustrator, DreamWeaver 2, SoundForge, and Windows. Mac ability a plus.

**HireKnowledge Manager • San Francisco** • Join the HireKnowledge Team! The ideal candidate will have prior sales and/or recruiting experience, and basic troubleshooting, networking and graphics knowledge. We are looking for an enthusiastic self-starter, with 1-2 years of professional experience and a great attitude. The job involves aspects of human resources, sales, marketing and management.

**Word Processing Department Coordinator • New York** • This position involves maintaining and developing client databases, facilitating major mailings for all clients, and managing and expanding the department to include for-profit projects. Proficiency in Windows (Word, Excel, Access), FileMaker Pro or comparable database required, network and internet familiarity preferred.

<http://www.hireknowledge.com>

**Interactive Web Architect • Dallas** • Internet-based interactive multimedia educational company wants to add another member to their team. Applicants must have a degree in Cognitive Science or an equivalent and have a minimum of one years experience with HTML, SQL, Java, Cold Fusion and WebStar. The ability to work effectively in both a Windows NT and Macintosh web hosting/serving environments is essential.

**Senior Systems Engineer • Chicago** • Large hospital organization in SW suburbs is seeking a Sr. System Engineer with 5 years of experience in a similar environment. The ideal candidate would be a CCNA, CNE, MCP or MCSE with extensive experience with CISCO routers and leadership experience. You will work individually and with a team of engineers. Experience with Windows NT and Novell required; a degree is preferred.

**Customer Service Representative • New York** • Friendly and articulate troubleshooters needed to answer incoming calls from current and potential customers, respond to inquiries and requests for assistance with the client's financial planning and analysis software program, identify problems, and provide advice to assist users.

**Web Technology Manager • Boston** • We are looking for candidates who can build and maintain effective web technology environments that support corporate intranet and external websites. Responsibilities include application design, development, deployment and overall technical maintenance.

**Graphics Assistant • Philadelphia** • This is a production support position which involves the coordination and input of text and graphics and other visual aids materials, primarily for presentations. Candidates must be proficient in MS Word, Excel, PowerPoint and a PC graphics package.

**Locations**  
Baltimore  
Boston  
Chicago  
Dallas  
New York  
Philadelphia  
Providence  
San Francisco  
St. Louis  
Washington DC

**Web Programmers • St. Louis** • We need tricked-out, back-end web programmers — ones who can write straight HTML and Java code, and who have professional experience with JavaScript, ASP, SQL and Visual basic. Flash experts please report immediately as well.

**Senior Software Engineer • Baltimore** • Join this exciting start-up e-commerce company, which is quickly becoming one of the nation's most respected travel companies. This position requires full life cycle experience from requirements definition through product release. You will need to have in depth knowledge of Java, SQL, CORBA and RMI as well as knowledge of object-oriented analysis and design and programming techniques, internet application development on the server side, RDB experience with JDBC, ODBC, Oracle and Access.

**800-937-3622**

call us

**Graphic Designers • St. Louis** • Design and production experts are always welcome to apply for a variety of ongoing full- and part-time positions. Top-notch skills in Quark, Photoshop and Illustrator and grace under pressure are what we are looking for.

**Web Developers • San Francisco** • We have several positions open for candidates experienced in HTML handcoding, CGI, NT info servers, SQL Data Base, Active Server Pages, and JavaScript.

# HireKnowledge

putting intelligence to work

**Macintosh/Windows Help Desk • Providence** • RI company is looking for MAC/PC gurus. Candidates must have extensive knowledge of networking, operating systems, cross-platform connectivity, hardware and software upgrades and troubleshooting.

**Access Programmer • Washington DC** • We are looking for individuals to do Microsoft Access Programming for various short and long term projects and contracts in the Metropolitan DC area. 2+ years of programming experience and samples of work required.

# HireKnowledge

<http://www.hireknowledge.com>



# Letters

## Digital Video for All?

**T**HE NEW IMACS LOOK GREAT (“The iMac Is Back,” January 2000)! It’s about time Apple created a Mac that retails for under \$1,000. My problem is that the iMac DV has what looks like some great digital-video-editing software—iMovie. I already own a blue-and-white G3 and would love to use iMovie, but Apple won’t sell it separately. I understand that it’s made for Macs with FireWire, so why won’t it work with all of them? What a waste! And don’t tell me to buy Final Cut Pro. If I had that much money, I’d buy a new iMac. Come on, Apple, wake up and smell the coffee. People want digital-video-editing software that costs less than a new computer. Give us a break and make iMovie available to all Mac users.

SANDRA HALL  
*Merrimack, New Hampshire*

**I** BECAME VERY DISCOURAGED AFTER reading about the new generation of iMacs. Let me see if I have this straight: I just spent almost \$1,500 upgrading to a new iMac because of its new features—DVD and digital-video editing. Now I learn that the DVD audio loses sync with the video and I’m unable to run a professional video-editing program on my new machine. I feel duped.

JOHN SEYMOUR  
*Knoxville, Tennessee*

## But I Like the Mouse

**Y**OUR MAGAZINE, LIKE MANY others, has criticized the Apple mouse and keyboard. True, most people need to adjust to the mouse, but all it takes is a different way of holding it. The mouse is great for kids; it fits their hands perfectly.



And after all, the iMac is a consumer item intended to be easy for children to use. Personally, I think the keyboard is better than others; it has a crisper response and takes up less space. I’ve learned to use the mouse, too. While I think you should let readers know that the keyboard and mouse are different, that doesn’t mean you should criticize them so strongly.

S. LIU  
*San Francisco, California*

## Designer Bloodlust

**T**HE DEBATE OVER WHICH IS BETTER, QuarkXPress or Adobe InDesign (“QuarkXPress versus InDesign: The Great Debate,” January 2000) ignored a crucial product feature—customer support. Adobe’s excellent customer service beats Quark’s Machiavellian customer relations hands down. Now that Adobe offers an up-to-date page-design pro-

gram, Quark is roadkill. After enduring ten years of abuse from Quark, I look forward to the company’s demise. *Macworld*, please report Quark’s death throes in detail. I will savor them.

PATRICK ERTEL  
*Yellow Springs, Ohio*

**I** JUST USED ADOBE INDESIGN FOR a 71-page, camera-ready scientific document. Based on my experience, I believe the glowing praise of InDesign in your January 2000 issue is unwarranted.

One only has to look at the topics on Adobe’s own user forum to see what’s going on here. One forum, titled “Unbelievably Bad Performance,” cites numerous instances of molasses-like speed. I have a 400MHz G3 with 128MB of RAM assigned to InDesign. My article had 15 small photographs, but mostly comprised text set in a single PostScript type family. Small changes that caused linked text to reflow made my hard drive churn for 30 to 60 seconds, during which I couldn’t do anything else.

I also found it impossible to print to an Apple PostScript Level 2 printer with the supplied printer driver. Random substitution of individual characters was rampant. I had to export to PDF format and print from Acrobat Reader. Over 70 user-forum postings complained about printing problems, such as lack of support for any non-PostScript device—including all Epson ink-jets commonly used for proofing.

Since this is a young program, I’ll overlook that I desperately needed a table editor as well as indexing and table-of-contents capabilities. But features such as vertical text justification can be had in inexpensive, stable, and quick software such as Ready,Set,Go. On the plus side, *continues*



# Congratulations to the winners of the *Best of Show*

JANUARY 2000 EXPO!



Mac OS X  
Apple Computer  
[www.apple.com](http://www.apple.com)

Canon BJC-85 and  
PowerShot S20  
Canon  
[www.canon.ccsi.com](http://www.canon.ccsi.com)

Sound Blaster Live!  
Platinum  
Creative Labs  
[www.creative.com](http://www.creative.com)

IBM ViaVoice  
IBM  
[www.ibm.com  
/software/speech](http://www.ibm.com/software/speech)

Dreamweaver 3/  
Fireworks 3  
Macromedia  
[www.macromedia.com](http://www.macromedia.com)

Internet Explorer 5.0  
Microsoft  
[www.microsoft.com](http://www.microsoft.com)

Sancube  
Micronet  
[www.micronet.com](http://www.micronet.com)

Invigorator  
Zaxwerks  
[www.zaxwerks.com](http://www.zaxwerks.com)

**Macworld**  
**BEST of SHOW**  
2000 SAN FRANCISCO EXPO

## LETTERS

InDesign's Multi-line Composer does set gorgeous type.

It seems to me that Adobe let fly with nothing more than a quirky beta version. My advice to readers is to hang on to their money and let this software age for a while.

RON GRAHAM  
Salem, Oregon

*We recommend that you try Adobe FrameMaker (800/833-6687, [www.adobe.com](http://www.adobe.com)) for scientific or very long documents.—Ed.*

### Don't Slam the Rugged iBook

ANDREW GORE'S REVIEW OF THE iBook (*Reviews*, January 2000) was pretty rough on this new product, although rightly so in terms of the iBook needing at least 64MB of RAM and more ease-of-use features, including a separate numeric keypad. However, if you have a child who has bad handwriting, the iBook could be a very useful tool. It's rugged, the function keys are easily programmable, the keyboard is quiet, and the inexpensive wireless option allows students to print to a remote printer or connect to the Internet while in a classroom. Computers and typing are generally seen as disruptive in a classroom. Too often, they are relegated to separate computer labs as if they were not relevant to a student's primary studies. Please be aware that the iBook is targeted at educational users. It has one-of-a-kind features that may change the way things are done in a classroom.

DAVID WERLING  
Little Rock, Arkansas

### AOL Doesn't Play Well with Others

WE BOUGHT ONE OF THE FIRST available AirPort setups for the iBook. We installed the AirPort but couldn't get it to connect with America Online (AOL), so we took it back to the store. After eight days of effort and repeated conversations with Apple, the people at the store informed us that the AirPort is incompatible with AOL—despite the fact that Apple installed AOL on the iBook.

How could Apple put out a communication product incompatible with the largest portal in the country? We bought our first Macintosh in 1984. We

were hoping that Apple was on the way to recovery. We are so sad.

JOHN AND BETSY ROBINSON  
Oakland, California

*Unfortunately, America Online does not adhere to the industry-standard PPP connection method. Therefore, it's not compatible with the AirPort.—Ed.*

### Infrared Secrets Not So Hot

YOUR ARTICLE "JOIN THE INFRARED Revival" (*Secrets*, January 2000) was very timely, as it hit my desk within days of the arrival of my new PowerBook G3. Unfortunately, almost all the information in the article was out-of-date, as I soon discovered while attempting to share files with a bronze PowerBook and HotSync with my Palm V. It seems that the latest PowerBooks, whether they ship with OS 8.6 or OS 9, use only the IrDA protocol, not the IRTalk option recommended in the article. No Apple IR File Exchange exists either.

A trip to Palm Computing's Web site revealed that Palm, too, was ahead of Mr. Schorr. The latest Palm Desktop software, version 2.5, defaulted to an infrared connection on install, and I couldn't find a Palm Extras folder, described in the *Macworld* piece, in the new install or on the Web page specified.

I know it takes time to get an article to press, but this PowerBook G3 information was months out-of-date.

STU MASCHWITZ  
San Francisco, California

*You're correct that the newest 400MHz PowerBook G3 Series computers support only IrDA, and Apple IR File Exchange works only with IRTalk.—Ed.*

### Lenticulatin' Macs

I JUST GOT YOUR LATEST ISSUE AND wanted to let you know that although you say there is no company that makes Mac software for lenticular technology ("Lenticular Art Comes of Age," *News*, January 2000), there actually is. Two weeks ago, I downloaded a Mac-only lenticular program from a company called Lexer ([www.lexer.com](http://www.lexer.com)).

MIKE CLEMENT  
Saint Louis, Missouri

*continues*



Presenting Visor™, the first truly expandable handheld computer. It may look like an ordinary organizer, but it is infinitely more than that. The secret lies in its revolutionary Springboard™ expansion slot. By simply inserting a module, your Visor allows you to read Peanut Press' Star Trek book series, not to mention an MP3 player, a pager, a Global Positioning System module and soon, much more.\* Plus, it also downloads thousands of existing Palm applications and the USB connection makes syncing to your computer easy. Starting at only \$149, the price is equally as intelligent. So visit [www.handspring.com](http://www.handspring.com) today. And see why Visor is collecting quite a loyal fan base of its own.

## Star Trek® Books.



\*Modules sold separately, availability may vary.  
Copyright ©2000 Handspring, Inc. All rights reserved. Handspring, Springboard, Visor, the Handspring logo and the Springboard logo are trademarks of Handspring, Inc., and may be registered in some jurisdictions. Palm OS is a trademark of Palm Computing, Inc., 3Com Corporation or its subsidiaries. Star Trek ® & ©2000 Paramount Pictures.

  
**handspring™**  
[www.handspring.com](http://www.handspring.com)

put our



Let the Macworld Lab help you make the right purchase decisions. Whether you depend on the stamp of approval of an Editors' Choice award, a five-mice rating, or the authoritative test data presented in our benchmark charts — you can put our lab to work for you.



Choice award, a five-mice rating, or the authoritative test data presented in our benchmark charts — you can put our lab to work for you.

Something obvious happens when a publication is backed by the most experienced, capable and thorough product testing in the Macintosh industry — more serious Mac buyers rely on it to make smart purchase decisions.

# Macworld



## Forty Bits Bites Back

I LAUGHED OUT LOUD AT JOE Lewis's gripe about 40-bit encryption ("Forty Bits Bites," *Letters*, January 2000). He complained that the AirPort's 40-bit encryption was inadequate, particularly for sending a 128-bit-encrypted secure Web communication. These fears are silly. For one thing, the range of AirPort transmissions is limited to 150 feet. In theory, someone could park outside your home or office and intercept, decode, and steal your credit-card number, but I doubt the cost of this surveillance would justify the limited yield. Also, while the 40-bit encryption occurs between the iBook transmitter and the AirPort, the 128-bit encryption occurs in the Mac. In fact, you'll see stronger encryption, as the 40-bit encryption is on top of your browser's 128-bit encryption.

People often confuse where security risks are. Hackers don't sit wielding antennas in your parking lot. They filter Internet transmissions along a server or other such places and then search them for credit-card and Social Security numbers. The AirPort's 40-bit encryption should be plenty for its purpose: to protect transmissions from anyone, such as a neighbor, who may be nearby listening with an AirPort-equipped Mac.

STEPHEN DENAGY  
*Idaho Falls, Idaho*

Letters should be sent to *Letters*, Macworld, 301 Howard St., 16th Fl., San Francisco, CA 94105; via fax, 415/442-0766; or electronically, to [letters@macworld.com](mailto:letters@macworld.com). Include a return address and daytime phone number. Due to the high volume of mail received, we can't respond personally to each letter. We reserve the right to edit all letters. All published letters become the property of *Macworld*.

### CORRECTIONS

We misidentified the name of Tektronix's site where artists and photographers post examples of their work ("Adobe Builds a New Web Presence," *News*, January 2000). The name of the site is *CreativeSight.com*.

We incorrectly stated that the iSub is powered by USB ("The iMac Is Back," *January 2000*). It requires an external power source. **m**





## iCandy.

The second thing you notice about the new Graphire™ tablets from Wacom is the mouse. Three buttons and a scrolling thumbwheel, no cord to knock over your coffee cup, no ball to clean— and it's five times more accurate than the iMac mouse. The third thing you discover is the famous Wacom pen, complete with DuoSwitch™, built-in eraser and 512 levels of pressure-sensitivity, so you have control over everything from drawing a quick sketch with your free copy of Painter Classic to signing your name.

The first thing you notice, however, is that at under \$100, that blueberry Graphire is looking pretty good. But so is the grape... and the lime... and the tangerine...

**WACOM**

800.922.2585 or  
[www.wacom.com/graphire5](http://www.wacom.com/graphire5)

©2000 Wacom Technology Corporation. Wacom is a registered trademark and Graphire is a trademark of Wacom Company Ltd. All rights reserved. Wacom products are available at [www.wacom.com](http://www.wacom.com), CompUSA, Microcenter and other fine retail and mail order resellers nationwide. Includes  Painter Classic.

Circle 84 on card or go to [www.macworld.com/getinfo](http://www.macworld.com/getinfo)



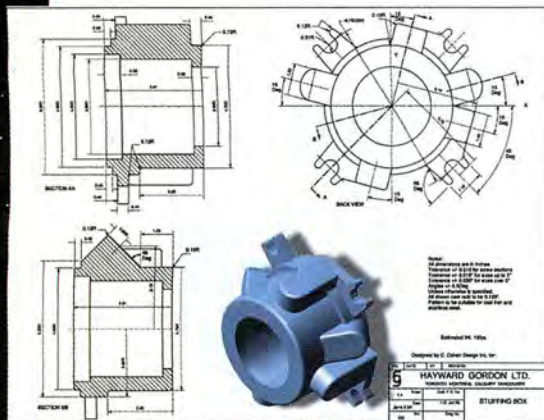

Carlos Cohen, C. Cohen Designs Inc., Toronto, Canada; Rendered with RenderWorks

# Introducing VectorWorks A Better Way to Design

After 14 years of constant research and development, Diehl Graphsoft is proud to introduce VectorWorks—the next generation of MiniCAD. VectorWorks improves MiniCAD's proven CAD technology and merges new state of the art Object-Based design philosophy. This integration makes you more productive without sacrificing flexibility and control.

## Increased Productivity with Object-Based Design

VectorWorks' state of the art Object Technology helps streamline the design process by making it easy to create common design elements. Now, Objects like doors, windows, nuts and bolts, can be created and edited with a click of the mouse, making it easy to explore design alternatives, consider "what if" scenarios, and handle last-minute client changes.

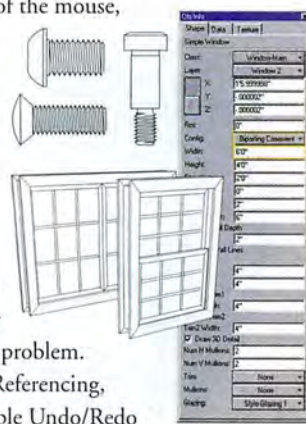

## The Strength of a Proven CAD Technology

VectorWorks offers a solid foundation based on proven CAD technology—giving you the power and flexibility to tackle any design problem. New features such as Workgroup Referencing, DWG (v.14), Round Walls, Multiple Undo/Redo and an improved scripting language, strengthen VectorWorks' core CAD capabilities. And, with RenderWorks, VectorWorks' new photo-realistic rendering plug-in, you can bring your designs to life with textures, shadows and dramatic lighting.

## The VectorWorks Advantage

With VectorWorks, you get it all—the flexibility and control of proven CAD technology and the productivity benefits of Object-Based design. VectorWorks ships FREE solutions for Architecture, Landscape Design, DTM and HVAC among others. Best of all, you aren't limited to the solutions we provide. VectorWorks is completely customizable, allowing you to create your own custom business solutions.

## Special Offer to Readers of Macworld

Save \$134 by purchasing VectorWorks with photorealistic rendering direct for \$1061 or, without rendering for only \$795. Includes FREE Tech Support and a 90-Day Money-Back Guarantee.



**Diehl Graphsoft Inc**  
Software for Today's Professional  
**1-888-646-4223**



Roberto Candusso, Arquitectos Associados, Sao Paulo, Brazil





# The Vision Thing

by Andrew Gore

## Scenes from an iMovie

GIVING NOVICES PRO VIDEO POWER DOESN'T MEAN THEY'LL ALSO HAVE PRO VIDEO TECHNIQUE

**R**UN TITLE, FADE TO Scene One. I'm in a restaurant, eating dinner with two friends. They're both in the movie business. We're talking about iMovie, Apple's new digital-video-editing tool that, in combination with a FireWire-equipped camcorder and an iMac DV, makes it possible for anyone, and I mean anyone, to create his or her own professional-looking movies.

"OK, I can see how it might give them the tools to make good-looking movies," one of my friends says. "But what about the technique?"

"iMovie handles transitions, fades, titling—even sound effects," I respond. "And the interface makes it pretty simple to figure out how everything works."

"How about blocking, pacing, lighting, camera angles, the elements of staging, and good storytelling?"

I counter: "Well, I guess it's just a case of garbage in, garbage out. We had the same problem at the beginning of desktop publishing—just because you can put 35 fonts on a page doesn't mean you should.

"What really matters is that the tools are here to give budding filmmakers the ability to express themselves—without hiring a film crew and a postproduction studio. And, hey, maybe you won't nod off during the next showing of *My Daughter's Prom Night*."

A pause. Then: "What about sound?"

### Foley Folly

Cross-cut to Scene Two: ominous music plays in the background. I don't claim to be a video expert, although as an AV buff, I've used most of the video-editing tools that have come and gone on the Mac platform. But until that dinner, it had not occurred to me to think about the problems of sound and digital video. Sound to me was just that second and third

track in the Adobe Premiere window.

But once I sat down to play with iMovie, and look at sound from an aesthetic as opposed to a technical perspective, I realized just how little I know about this simple fundamental of filmmaking.

So there I am, in my study, wrestling to make the sound *sound* right. But no matter what I do, I can't get there. The sound captured by the camera has just got too much ambient noise, no direction, and no leveling. And I can't separate the voice from the background. After years of watching films with multi-million-dollar soundtracks, it's almost



impossible for us to listen to unprocessed sound. The sound recorded by a camera is too realistic, and as a result comes off cheap and cheesy.

And here I am producing films that sound like they were recorded over a long-distance call from Nepal. (Excuse me while I hang up the tin can.)

### Story Bored

Scene Three. Cut from aerial shot of San Francisco into an office where a meeting is in progress. "So, we all agree that what most iMovie users really need is guidance." That's our features editor, Scholle

Sawyer, speaking. We've just finished a brainstorming session on how *Macworld* should cover digital video in general and iMovie in particular.

"No one is going to become a Spielberg after reading one article in *Macworld*," another editor chimes in. "But maybe we can give them enough advice so their next vacation video won't put the family to sleep."

Yes. Keep to the basics. Plan out your video before you shoot it by writing an outline, and stick with it. Make your scenes short, and no matter what, don't fall in love with your own footage, unless you want to be the only person who can sit through it. If you think it'll take ten minutes to tell your story, do it in five. If you think it'll take five, try to make it three.

Above all, set your expectations appropriately. Don't think MTV—think *America's Funniest Home Videos*. That way, you won't be disappointed. Remember, those MTV people work in million-dollar studios and have dozens of highly paid professionals who help make their videos look great. All you've got is a \$1,300 computer, a video camcorder, and a few hours of spare time.

Who knows? Maybe you will break through the barrier and be the big discovery at next year's Sundance Film Festival. But even if all you're doing is saving your houseguests from the boredom of an hourlong presentation of your trip to Hawaii, you will have accomplished something.

"Okay, that's a wrap." Scholle says as the meeting concludes. "Let's go make a great feature!"

Yes. Let's.

Fade out. Roll credits. **m**

Questions? Comments? E-mail them to Andy at [visionthing@macworld.com](mailto:visionthing@macworld.com).



# The Seven Deadly Macintosh Sins:



Software Conflicts

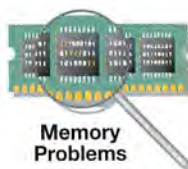

Memory Problems



Viruses



Hardware Problems

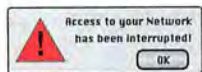

Network Problems



Disk Damage



Damaged Software

## Salvation:



When good Macs go bad and fall from grace, it's good to know there's help nearby. Salvation is only a mouse-click away with the new TechTool Pro 3. Now featuring virus protection and conflict detection, TechTool Pro is the only program you need to help abolish the evil forces that have possessed your Macintosh. TechTool Pro 3 checks more aspects of your Macintosh than any other utility available. Period. Besides repairing and recovering damaged drives, eradicating viruses and catching the occasional software conflict; you can also test all those other critical parts of your system that other utilities simply ignore. Like RAM, logic board components, floppy drives, scanners, modems, internet connections and so much more. TechTool Pro even supports technologies like System 9.0.1, "Pure" HFS+, Firewire and USB drives, and all of the latest Macintosh models.

TechTool Pro can also help you in between times of trouble. Our disk and directory optimize features can help

improve the performance of your Macintosh as well as help circumvent problems before they happen. The TechTool Protection control panel will regularly check your system so you don't have to. It will also back up critical directory data, so if something goes wrong, you'll be up and running in no time flat.

But just because TechTool Pro is the most advanced Macintosh troubleshooting utility available doesn't mean that it has to be difficult to use. Our easy-to-use interface makes checking and fixing your Macintosh as easy as pressing one button. For advanced users, expert access allows you to control and configure TechTool Pro in almost any way you wish.

So if Macintosh troubles are turning your life into a living Hades, check out the tool of the trade: TechTool Pro. After all, you have the most powerful computer in the world. Shouldn't you be using the most powerful utility?

**\*Purchase TechTool Pro 2 now and receive a free upgrade to TechTool Pro 3 when it ships in Q1 2000!**

MicroMat Inc.  
800-829-6227  
707-566-3831  
FAX: 707-566-3871  
info@micromat.com  
www.micromat.com



Fix different.™



\*Offer subject to change without notice. Offer expires April, 30 2000.

©2000 MicroMat Inc. All rights reserved. TechTool is a registered trademark of MicroMat Inc. Fix Different is a trademark of MicroMat Inc. Macintosh is a trademark of Apple Computer, Inc.

Circle 67 on card or go to [www.macworld.com/getinfo](http://www.macworld.com/getinfo)



online

## Is Apple Going All Out Online?

COMPANY TACKLES

INTERNET CONTENT WITH  
iREVIEW, KIDSAFE TOOLS

by Philip Michaels

**F**orget about sleek new PowerBooks and flashy operating systems. To hear Apple (800/767-2775, [www.apple.com](http://www.apple.com)) tell it, the future of the company includes more than just hardware and software. Indeed, its newly announced Internet strategy seems to be steering Apple toward the increasingly crowded neighborhood of online portals.

The strategy was unveiled at January's Macworld Expo by iCEO—that's *i* as in *Internet*, not *interim*—Steve Jobs. Apple has spruced up its Web site with new services and other tools that exploit the features in Mac OS 9 (see "Mac Tools Get OS-Specific," elsewhere in this section). Among the additions are a service that offers Web-site reviews and a tool that controls where kids can surf online.

**Reviews Revealed** The reviews feature—dubbed iReview—includes Web-site descriptions and ratings Apple has put together. The reviews cover 15 categories, such as computers, news, movies, and finance sites. Users can sug-

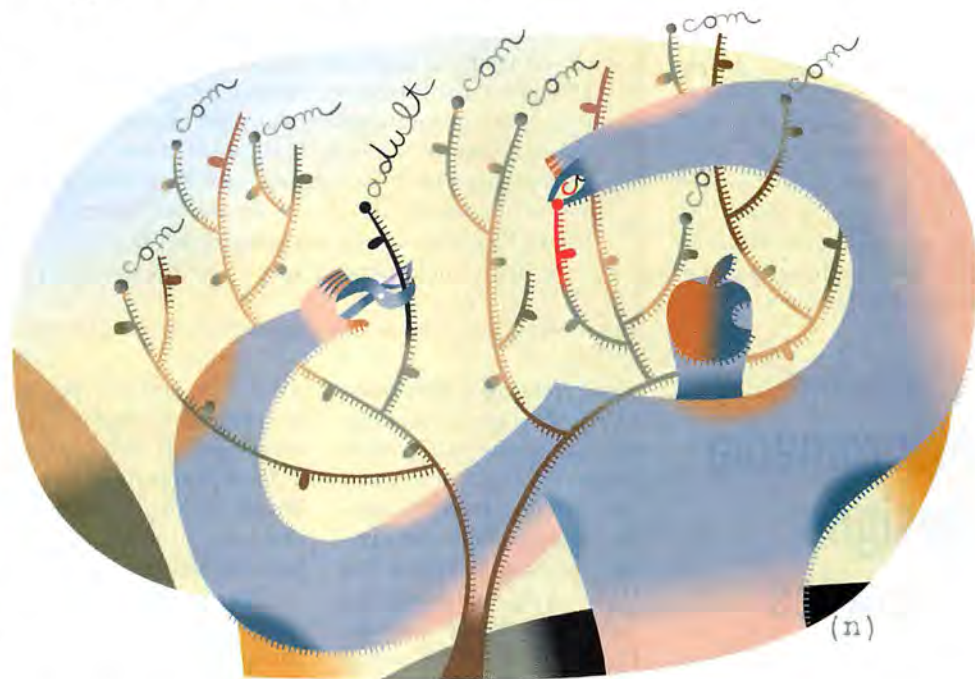

gest Web sites for Apple to review or can provide rankings of their own—but only if they sign up as members at Apple's Web site. And you can register only if you're using Mac OS 9.

"We're going to do for reviews what Amazon.com did for books and CDs," Jobs declared during his Macworld Expo keynote speech.

Of course, it's not quite that simple. Apple's foray into the world of Web reviews raises several questions about Apple's direction and inten-

tions. Who's responsible for the reviews, and what are their criteria? Who decides which sites to review? And most important, can users count on Apple to give objective, trustworthy reviews when dealing with the Web sites of its partners—or its rivals?

Apple's not planning to divulge the names of employees who write and publish iReview, citing the same company policy that exists for other products. But what works for hardware and software may not carry over so

well to the world of content.

**Safe at Home?** Apple's other venture into Web content is KidSafe, a tool that aims to protect children when they venture onto the Internet. Besides preventing kids from surfing adult Web sites, the feature can also disable e-mail, chat rooms, or games. Mac OS 9 users can download KidSafe from Apple's Web site and install it on their desktops. Parents can use OS 9's Multiple Users function to turn KidSafe off

*continues*



when they're on the computer.

KidSafe works differently from most filtering programs. Those programs specify what kids can't see, using words and terms to block forbidden sites. KidSafe, on the other hand, specifies what children *can* see, using a database of 50,000 approved Web sites. A panel of teachers and librarians selects those sites; Jobs says Apple will add 10,000 Web sites to its KidSafe database each month.

That approach is an effective way to protect kids, online-safety experts say. But it has its drawbacks, too. No matter how thorough Apple's database, people using KidSafe still have to accept limitations they may not always agree with. Parents can add approved Web sites to KidSafe, but the majority of the decisions over what's appropriate have been made for them.

#### multimedia

## Macromedia Designs Upgrades

FREEHAND, DIRECTOR  
GET TIMESAVING TOOLS

by Frith Breitzer

**T**wo of Macromedia's (800/457-1774, [www.macromedia.com](http://www.macromedia.com)) most venerable programs will get upgrades this year. FreeHand 9 and Director 8 boast new tools that further integrate the company's product line and aim to streamline the design process.

Macromedia may believe the future of design lies online, but the company is still serving print designers,

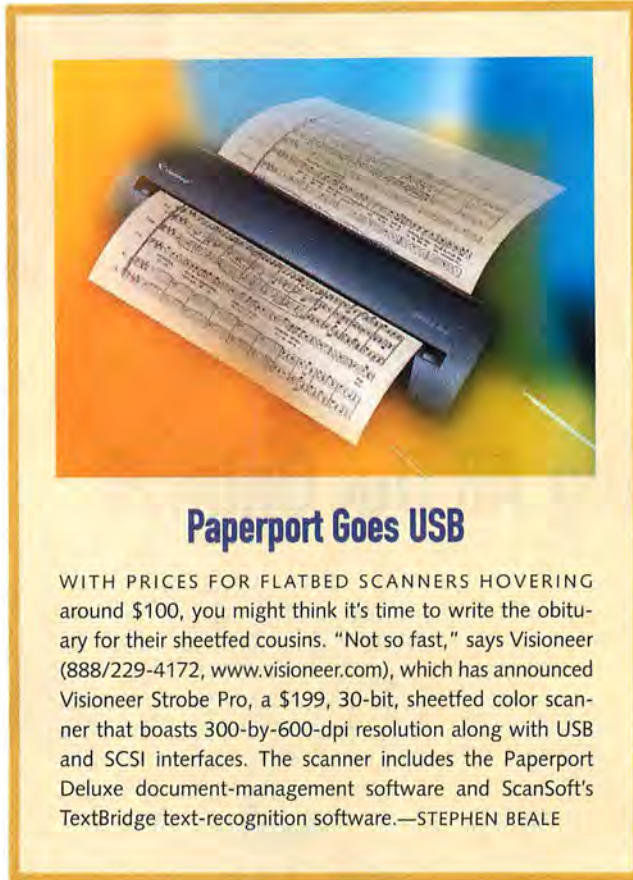

### Paperport Goes USB

WITH PRICES FOR FLATBED SCANNERS HOVERING around \$100, you might think it's time to write the obituary for their sheetfed cousins. "Not so fast," says Visioneer (888/229-4172, [www.visioneer.com](http://www.visioneer.com)), which has announced Visioneer Strobe Pro, a \$199, 30-bit, sheetfed color scanner that boasts 300-by-600-dpi resolution along with USB and SCSI interfaces. The scanner includes the Paperport Deluxe document-management software and ScanSoft's TextBridge text-recognition software.—STEPHEN BEALE

with FreeHand 9. Previously, Macromedia positioned FreeHand as a print and Internet graphics tool. It now trumpets the product as "the professional illustration and layout solution for print and Web" and emphasizes the tight integration between FreeHand and Web design products such as Flash.

Recognizing that many customers already use FreeHand to lay out print products, Macromedia added new print-oriented features. FreeHand 9 supports a simpler multipage-management scheme, ColorSync support, linked file management, and customized page sizes.

**Dash for Flash** At the same time, Macromedia is pushing FreeHand as a sophisticated design tool, ideal for creating graphics and storyboards for Flash presentations. FreeHand 9 supports the export of native

SWF files, and you can use the program's layers as Flash animations. It also supports a Flash-compatible symbol library, making it easier for designers to share graphics between programs.

Among FreeHand 9's new features are a perspective-grid illustration to help designers place artwork in a three-dimensional perspective framework, live enveloping that lets users warp and distort graphics precisely, custom scaling, magic-wand tracing, and editable vector transparency. Users can also open FreeHand files in Adobe Photoshop with layers intact and produce and edit Portable Document Format (PDF) documents within FreeHand.

**Director's Cut** Macromedia has given Director 8 Shockwave Studio a makeover, hoping to encourage marketers and Web-site developers to think of the

program as a means of creating engaging, dynamic content quickly and easily. The new release streamlines the Shockwave authoring process with timesaving features and offers new optimization and compression schemes.

A new Property Inspector window centralizes editing operations and allows batch editing. Director 8 has guides to make layouts more precise. It also lets users lock objects so no one can edit them inadvertently. Other features let developers sort cast members by name, size, date, type, and comments.

Director 8 adds 70 new Lingo commands, which add new effects and behaviors, such as imaging and sound effects, to presentations. The program now features built-in JPEG compression, loader movies that play while content loads in the browser, and scalable presentations.

FreeHand 9 retails for \$399, while an upgrade sells for \$149. Director 8 Shockwave Studio sells for \$999, and an upgrade costs \$499.

#### multimedia

## Creative Labs Makes Noise

PC SOUND-CARD LEADER  
TO INCLUDE OFFERINGS  
FOR MAC USERS

by Philip Michaels

**F**or Macintosh gamers, the good news keeps coming. In the past year alone, game enthusiasts have seen enhanced graphics, stronger support from developers, and a slew of new games. And now the leading maker of PC sound cards is taking



its act to the Macintosh.

Creative Labs (800/998-1000, [www.creative.com](http://www.creative.com)) will release Mac versions of its Sound Blaster Live line of sound cards, some of the most common and compatible sound cards for PC users. Creative estimates that more than 60 percent of all PC audio systems use the company's Sound Blaster technology.

**New Options** Unlike PCs, Macs have always come with built-in sound. But Mac users who wanted to improve the quality of their built-in sound systems found they had few options. The lack of a quality consumer-level sound card hit Mac gaming enthusiasts especially hard. Creative's move to the Mac should change that.

The company's decision is another sign of Apple's resurgence. Indeed, Creative cited the Mac's recent good fortunes and the success of the company's own personal-digital-entertainment products as the reasons it decided to broaden its reach.

Sound Blaster Live cards for the Mac are set to

debut in the second quarter of 2000. They mirror the cards Creative makes for the PC. The Sound Blaster Live X-Gamer promises better gaming through digital sound. The Sound Blaster Live MP3+ is Creative's sound card for Internet music. The Sound Blaster Live Platinum combines the strengths of both cards to support games and MP3 files.

**Souped-Up Sound** So if these are just Mac versions of existing PC products, what's the big deal? Creative says Sound Blaster Live cards add environmental audio, surround sound, and a level of

realism not currently available from the Macintosh. "People want a high-quality audio experience," said Craig McHugh, president of Creative Labs. "They shouldn't be limited to what comes in the desktop."

The cards are powered by Creative's Emu10K1 processor, which handles sound and effects in real time without any drop in quality, leaving your computer's processor free to tackle other tasks.

**Going Nomadic** The company also plans to release Mac versions of products from its personal-digital-entertainment line. It's launching its WebCam Go camera and its Nomad portable MP3 player in February. Both products may already be available by the time you read this.

The portable WebCam Go doubles as a digital still and video camera. In addition, this USB device can capture images off the Internet and download them into e-mail and reports. Creative's new portable digital-audio player, the Nomad II, lets users download and listen

to MP3 files. The company touts the reprogrammable device as "future proof," meaning it will let users upgrade to future audio-compression standards via downloads. The Nomad II doubles as a voice recorder and has a built-in FM tuner.

Creative plans to keep Macintosh sound-card prices in line with what it charges for PC products—\$99 for the Sound Blaster

Live X-Gamer and MP3+, and \$199 for the Sound Blaster Live Platinum. The WebCam Go will sell for \$149. Prices for the Nomad II will range from \$199 for the no-memory version to \$399 for the 64MB model.

online

## Mac Tools Get OS-Specific

INTERNET STRATEGY

PUSHES SPECIAL

FEATURES FOR OS 9

by Frith Breitner

Steve Jobs has been telling people for almost two years that *i* is for *Internet*. And with the launch of the new *iTools* features on the Apple Web site and a multi-million-dollar deal with EarthLink, Apple seems to be re-making itself as a company that can compete in every arena of the computer market—in hardware, software, and Web services and as an Internet service provider.

Take Apple's \$200 million investment in EarthLink. Under the terms of the multiyear deal, EarthLink becomes the default ISP for every new Mac. Apple, in turn, profits from every new EarthLink Mac customer and gets a seat on the company's board of directors. The deal aims to boost Apple's income while giving Mac users a streamlined service that offers Mac-friendly tech support.

**Disk Driver** At the crux of Apple's Internet strategy are the new *iTools* announced by Jobs. Besides the Internet screening tool, Kid-

Safe, there's *iDisk*, which gives Mac OS 9 users 20MB of free storage on Apple's secure servers. *iDisk* works with OS 9 to let users transfer files among Macs or share documents with drag-and-drop simplicity. That feature resembles the free storage services from Driveway.com and FreeMacSpace.com.

The *iDisk* service also lets Apple enter the free-homepage market, which companies such as Geocities and Tripod currently dominate. With Apple's *HomePage iTool*, users can choose from several templates for setting up basic Web sites. Users can also create sites in other programs and place them in a public folder.

**Macintosh Mail?** Apple's fourth *iTool* offers free e-mail accounts through the Mac.com domain. However, the service does not compete with other free e-mail offerings such as Microsoft's Hotmail, because Mac.com is not a Web-based program. Users have to check their e-mail through a third-party program such as Microsoft Outlook Express or Qualcomm's Eudora.

Because these *iTools* are available only to Mac OS 9 users, one goal of Apple's Internet strategy may be to give users of older operating systems a reason to upgrade. Mac OS 9 costs \$99.

Apple's Internet strategy also includes *iCards*, the company's answer to the Blue Mountain Arts greeting-card site. *iCards* allows all Web surfers—including Windows users—to send e-mail greeting cards that appear within recipients' mailboxes rather than at separate URLs. Users can adorn their *iCards* with everything from Monet and Degas artwork to pictures from Apple's "Think Different" ad campaign.

*continues*

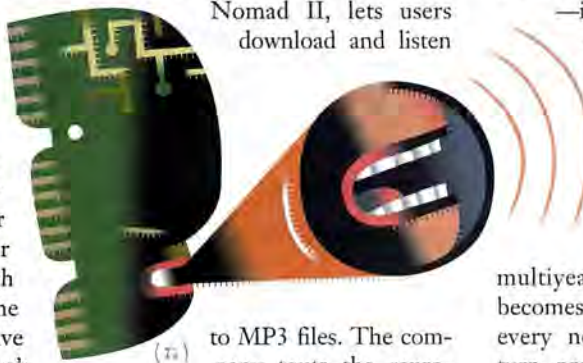



# Product WATCH

**Blazing Scanners** Epson (800/463-7766, [www.epson.com](http://www.epson.com)) and Umax (800/562-0311, [www.umax.com](http://www.umax.com)) have announced FireWire scanners. Epson's **Expression 1600** is available in a Pro FireWire configuration. The scanner features 1,600-dpi true resolution and retails for \$1,399. Umax's dedicated FireWire **PowerLook 1100** has 1,200-by-2,400-dpi resolution and is available with various software bundles starting at \$999.

**And the Beat Goes On** Beatware (650/556-7900, [www.beatware.com](http://www.beatware.com)) has announced **e-Picture 2.0**, an update to its Web animation program. This version features advanced animation effects and can export to QuickTime, Flash, and SVG formats. The program ships at the end of the March and sells for \$179. An upgrade costs \$49.

**Giga-Size Storage** Pushing gigabyte technology further along, LaCie (816/483-0755, [www.lacie.com](http://www.lacie.com)) has announced the revamped **PocketDrive** line of hard drives. The new PocketDrives are the first peripherals that offer both USB and FireWire support. Available in 6GB and 18GB capacities, they measure only 3.5 by 5.75 inches and weigh less than a pound. They should be available in February for around \$399 for the 6GB drive and \$749 for the 18GB drive.  
—EDITED BY FRITH BREITZER

## publishing

# Adobe Places PDF Tools in Production

ADOBE PLUG-INS TARGET ACROBAT DOCUMENTS

by Philip Michaels

**W**hen Adobe (800/833-6687, [www.adobe.com](http://www.adobe.com)) released Acrobat 4.0 with several Windows-only plug-ins, Mac users cried foul. But with the launch of InProduction, Mac print production professionals now have Acrobat tools to call their very own.

InProduction brings together five integrated Portable Document Format (PDF) print production tools in a plug-in for Acrobat 4.0.5. Although some of these capabilities are available in third-party applications, InProduction promises to save users time and reduce the chance of error involved in switching among programs.

**Five Tools** InProduction tools include Preflight, which creates reusable profiles to inspect PDF documents for output and display errors, and Separator, for specifying, pre-viewing, and creating color separations. Until now, Lantana's Crackerjack 3.0 was the only plug-in that could produce color separations from Acrobat files.

Other InProduction offerings include Trim/Bleed, which helps users define image areas and alter media, bleed, trim, or art boxes for accurate positioning. Color Converter provides multiple options for converting into CMYK, and Adobe in-RIP Trapping lets users specify

## News

trapping parameters for later execution in an Adobe PostScript 3 RIP.

For now, only Mac users have access to those tools. Adobe plans to release a Windows version of InProduction eventually.

That's a sharp contrast to the controversy over Acrobat 4.0. Adobe didn't develop plug-ins such as Web Capture, Compare Page, Digital Signatures, and Send Mail for the Macintosh, arguing that those tools weren't key to Mac users. But user outcry spurred the company to ultimately release Macintosh versions.

InProduction should ship this spring. Users can buy Acrobat 4.0.5, InProduction, and the Adobe Gamma utility for \$899. Acrobat 4.0 users can get an upgrade to 4.0.5, InProduction, and Gamma for \$699.

## publishing

# Digital-Photo Biz Developing

ONLINE LABS TURN DIGITAL FILES INTO FINISHED PRINTS

by Frith Breitzer

**L**ow prices and better pictures have made digital cameras a more attractive alternative to traditional film photography. The problem? The images people send electronically to friends and family lack the tactile intimacy, portability, and accessibility of printed photos.

Several online companies hope to overcome that hurdle. And they're turning

to an old standby—photo prints—to help them do it.

**Photo Finishers** Shutterfly (650/610-5200, [www.shutterfly.com](http://www.shutterfly.com)), PhotoAccess (206/264-2488, [www.photoaccess.com](http://www.photoaccess.com)), and Ofoto (510/647-0514, [www.ofoto.com](http://www.ofoto.com)) either offer or have announced ser-

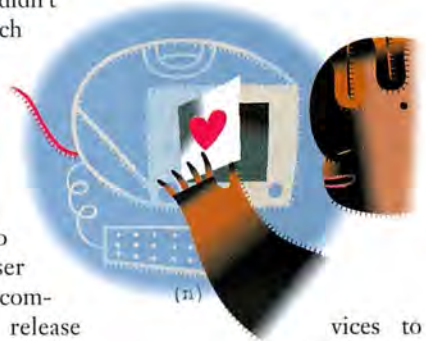

VICES TO process images from digital cameras.

It's just like dropping off film at a Fotomat, except customers never leave their computers. They just send these companies digital image files over the Internet. The services then turn the files into photo-quality silver-halide prints and send them back via snail mail. They also let users create online photo albums, from which friends and relatives can order prints.

**Quick Pix** Digital-image processors charge around 50 cents for a 4-by-6-inch print and several dollars for larger sizes. Instead of running to the photo lab to drop off and pick up prints, customers can order from their computers. Instead of printing every picture on a roll of film, they can look at their digital files and pick which ones to keep.

Companies offering digital photofinishing services have a large market to conquer. Their challenge? Making consumers aware of the technology that can turn their digital images into photo prints. If they can pull that off, digital cameras could evolve from high-tech toys to everyday tools.



# Until Now Your View Of The World Has Been Distorted.



*The award-winning Diamond Pro 900u (19-inch CRT/18.0-inch DVI\*) is truly distortion-free with a perfectly flat screen surface.*

If you're using a conventional CRT monitor, your eyes and brain are working overtime to correct for the curvature. Now, however, with its DIAMONDTRON NF™ (Natural Flat) family, Mitsubishi has completely revolutionized monitor technology. With a perfectly flat screen from edge to edge and truly distortion-free imagery, you'll experience an unprecedented improvement in viewing pleasure. Not to mention the dazzling brightness, razor-sharp clarity and stunning color accuracy which puts Mitsubishi in a class by itself. With no curvature, reflections and glare are also eliminated. The result is remarkably realistic, natural-looking flat images. Your energy can now be spent being more creative and more productive. For added versatility, DIAMONDTRON NF monitors feature a unique self-powered USB hub which allows you to switch all connected USB peripherals between

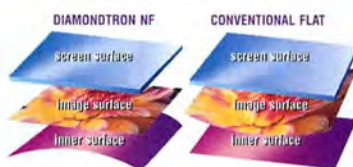

two computers automatically. With DIAMONDTRON NF monitors, Mitsubishi will forever change your view of the world. The difference is right before your eyes. For more information on the award-winning Diamond Pro 900u (19-inch CRT/18.0-inch DVI\*) and new Diamond Pro 2020u (22-inch CRT/20-inch DVI\*) models, contact Mitsubishi Electronics today.

**MITSUBISHI**  
DISPLAY PRODUCTS  
*Innovation On Display<sub>sm</sub>*

USA: 800-843-2515 • Canada: 800-387-9630 • QWIKFAX: 800-937-2094 • [www.naturalflat.com/pb/mwd/nf](http://www.naturalflat.com/pb/mwd/nf)

See the difference at:



Diamond Pro 900u  
July 1999

Diamond Pro 2020u  
June 1999

Diamond Pro 2020u  
June 1999

Diamond Pro 900u  
Jan. 19, 1999

Diamond Pro 900u  
March 1999

Diamond Pro 900u  
February 1999





## **Go Wide.**

**Introducing the new HP DeskJet 1220C printer designed for the Mac.**

If your work demands a wider range of capabilities, the Mac-compatible HP DeskJet 1220C delivers the big picture — up to 13" x 19" including 11" x 17" full bleed — *right out of the box*. It features HP's enhanced Color Layering Technology for true-to-the-original printouts and an alternative 2400 x 1200-dpi mode using photo paper. With speeds up to



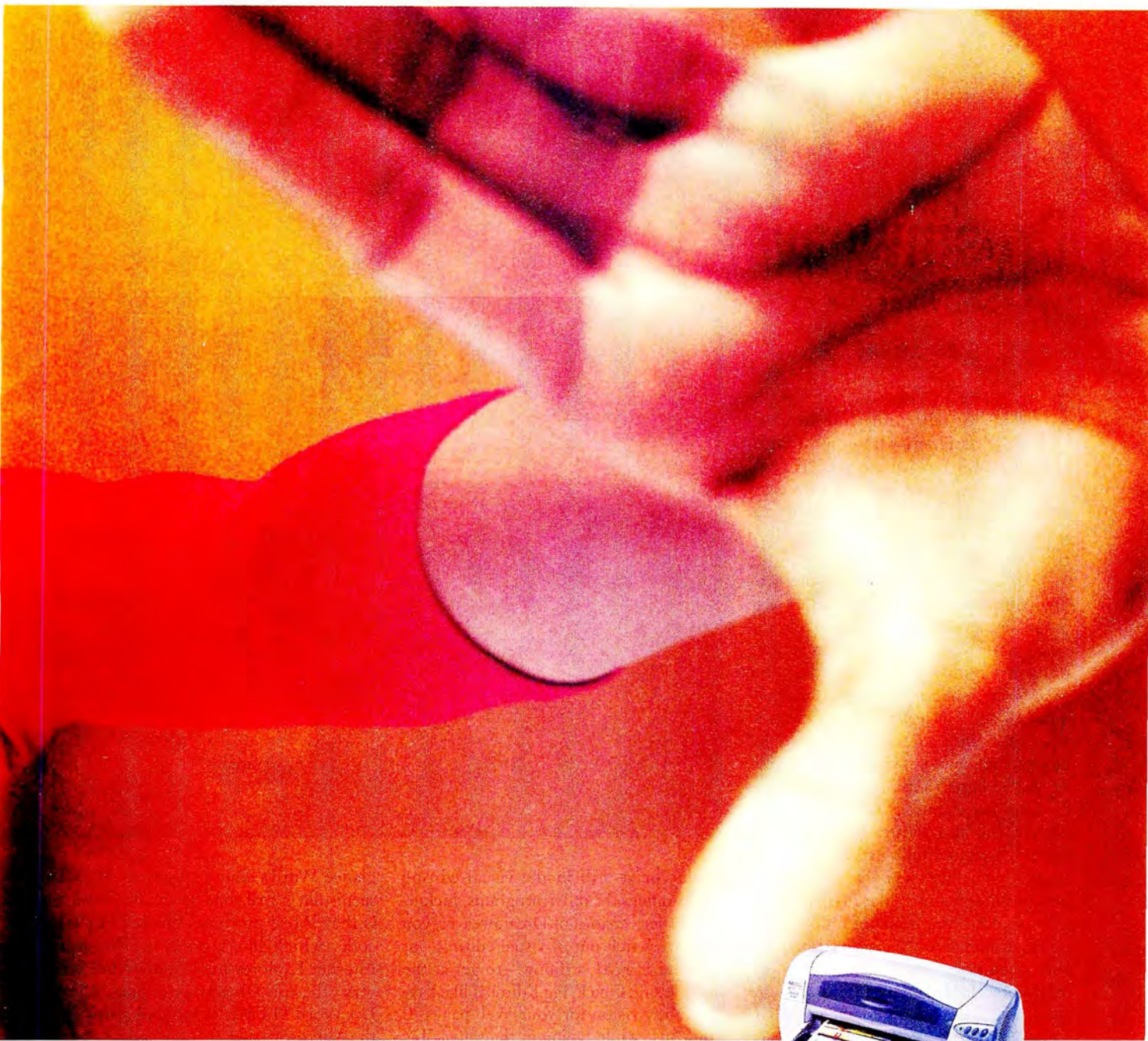

## Go Wild!

**Big, brilliant color printouts up to 13" x 19"!**

11 ppm for black and 9.5 ppm for text and graphics, you can go as wild as you want and still print faster than you ever thought possible. Stop by your HP retailer today. Discover how wide great printing can be. **True to the Original.**

© 2000 by Hewlett-Packard Company



\$499\*

\*Estimated U.S. retail price



# Reviews

## Dreamweaver 3

WEB TOOL WAKES UP

WEB SITE BUILDERS

**W**EB EDITING TOOLS HAVE to walk a fine line between designers who don't want to get bogged down by HTML and programmers who want the kind of control only code-hacking can provide. Dreamweaver 3 finally calls a truce between these two sides.

Dreamweaver 3 builds on the program's traditional strengths, such as page templates, strong site management, and respect for your HTML code (unlike other programs, it won't rewrite your HTML or JavaScript when you switch to visual mode). The new version has innovative page-editing tools, better features for design teams, and unparalleled extensibility that add up to a must-have upgrade.

One big change is under the hood. Macromedia has rewritten Dreamweaver 3 from scratch as a fully native Macintosh application, unlike its predecessors, which behaved suspiciously like fugitive Windows applications. Many of the interface quirks that annoyed Mac users in the past have gone away, and Dreamweaver now supports such Mac OS features as window shades, spring-loaded folders, and Navigation Services.

### Better Page Editing

Dreamweaver 3's new Quick Tag Editor should thrill HTML jockeys. This pop-up window lets you view and edit the underlying HTML code for any object

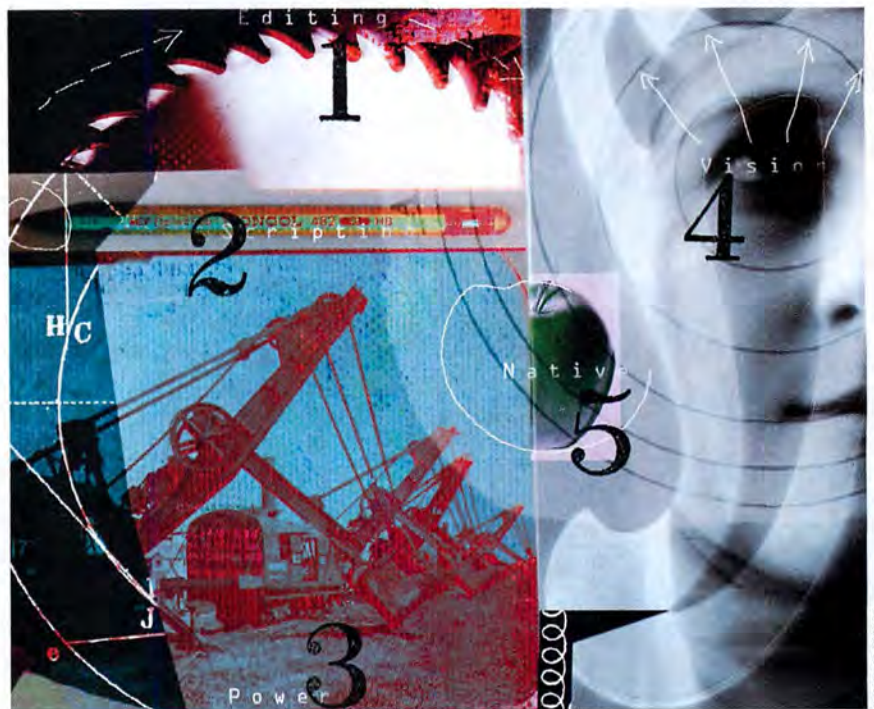

while you're still in the visual-editing environment. In other programs, including earlier versions of Dreamweaver, you have to switch out of visual editing—or open an HTML window—to get at the code. Using Quick Tag Editor is like having X-ray vision for your Web pages. If you pause while typing in the Quick Tag Editor, a pop-up window shows all the HTML tags Dreamweaver understands. The list is context-sensitive, so if you, pause on a tag, a list of attributes appears.

Much text that ends up on Web pages begins in Microsoft Word, and at first

glance Word's ability to save as HTML seems like a real time-saver. The trouble is that Word produces bloated HTML code, which looks great in Microsoft Internet Explorer for Windows but isn't very efficient. Dreamweaver's new Clean Up Word HTML command strips out the Microsoft-specific junk and produces cleaner, smaller Web pages. Excel users will appreciate the new Insert Tabular Data command, which converts any text-only tab-delimited file into a table.

The ability to create and apply paragraph and character styles is a cornerstone

REAL PRODUCTS  
REAL RATINGS

Reviews you can trust: Macworld rates only final shipping products, not prototypes. What we review is what you can actually buy.

OUTSTANDING: ★★★★★

VERY GOOD: ★★★★

GOOD: ★★★

FLAWED: ★★

UNACCEPTABLE: ★



of any decent word-processing program, but these features are hard to implement in Web designs. The problem is that you have to decide between font-tag attributes and Cascading Style Sheets (CSS). CSS styles are flexible, but display reliably only in recent browser versions (4.0 or later), and even then they often exhibit problems, such as type that appears in unreadably small sizes. Font-tag attributes display correctly in any browser, but applying multiple tags to a selection—say, for font, size, and type style—is time-consuming. The new HTML Styles palette lets you store multiple font-tag attributes as a style and apply them with a click. Dreamweaver stores the site's HTML Styles in an XML document within the site folder, making the styles available to anyone who works on your site.

The new Design Notes feature solves a key problem Web-building teams face: keeping track of who made what changes, and when. Dreamweaver maintains a Design Note, a separate XML document to which you can add date-stamped comments.

Often the teams that build sites, especially larger ones, are using both Macs and Windows PCs. Until recently, Dreamweaver was the most popular cross-platform HTML program among design pros. Adobe finally stepped up to the plate with GoLive 4.0 for Windows, but it has a significant limitation—you can't interchange its project files with those of GoLive for Macintosh. This throws up unnecessary barriers for Mac-and-Windows teams collaborating on Web sites.

Dreamweaver 3 negates some of GoLive's advantages by adding new objects with prebuilt frame sets, special characters such as copyright or euro symbols, and easier addition of e-mail links. Like GoLive, Dreamweaver's Site Window can synchronize a remote site with a local version.

### Need More? Build It!

Beginning with Dreamweaver 2, you could extend the software using JavaScript and HTML. Dreamweaver 3 takes customization into the stratosphere. It defines everything, including menus, palettes, dialog boxes, and the entire feature set, as some combination of HTML files, XML files, and JavaScript. If you can think of a feature, you can create it and add it to one of Dreamweaver's menus.

Developers have jumped on this ability with a vengeance. Hundreds of additional objects, commands, and behaviors are now available on Macromedia's

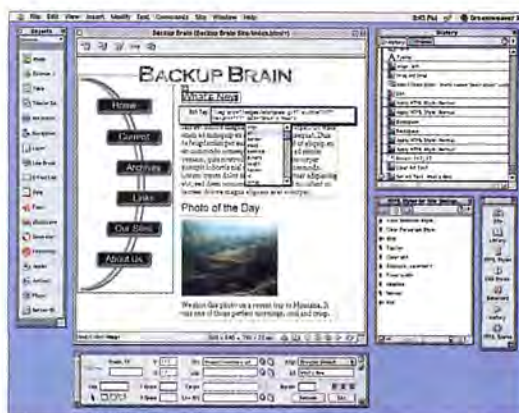

**A Quick Dip into the Code** With the new Quick Tag Editor, it's easy to inspect and change the underlying HTML for any object.

Dreamweaver Exchange Web site. JavaScript's cross-platform nature makes it a scripting tool superior to proprietary languages such as AppleScript or Visual Basic.

The ability to customize the menu system is a boon for design shops, which can give a simplified, custom version of Dreamweaver to their clients. This version could, for example, omit Dreamweaver commands an inexperienced client might misuse, while including new commands that make it easier to create content pages from prebuilt templates.

Extendability in Dreamweaver 3 isn't just for programmers. The new History palette keeps track of what you've done, and a slider bar lets you move backward and forward through your actions. It's the ultimate undo and redo feature. The only limitation is that the History palette just records keyboard actions, not mouse clicks and drags. The best part is that you can automate your work by selecting steps in the palette and choosing the Save As Command. After you name the new command, it appears in the Commands menu.

### Web Graphics Just a Click Away

Macromedia timed the revision of its Web graphics tool, Fireworks 3, to coincide with the release of Dreamweaver 3, and the two programs make a potent combination. From Dreamweaver, you can click on a graphic to edit or optimize it in Fireworks, which returns the modified image smoothly to Dreamweaver. Dreamweaver understands rollovers and other JavaScript created in Fireworks, so navigation bars, buttons, and image maps built in Fireworks drop into your Web layout with the Insert Fireworks HTML command; the links update automatically. Because both programs are completely scriptable via Java-

Script, programmers can write scripts that drive Fireworks from Dreamweaver or vice versa. For example, you can create a script that optimizes and makes thumbnails of a series of Fireworks images, then builds a Web page of the thumbnails, linking each one to pages containing the larger optimized images. Macromedia sells the two programs together as the \$399 Dreamweaver 3 Fireworks 3 Studio.

### Macworld's Buying Advice

Dreamweaver 3 is an excellent successor to an already good Web design tool. It finally gets rid of the weird pseudo-Windows interface in previous versions in favor of a real Mac look-and-feel. Dreamweaver 3 starts off the latest round of innovation in Web design tools, and Adobe is readying its reply with the next version of GoLive. Because it was cross-platform right from the start, Dreamweaver built a large, loyal customer base, enabling Macromedia to improve Dreamweaver on a fast Internet time scale. Now that GoLive has gone more than a year without significant revision, Adobe faces a real challenge to maintain its user base.

Dreamweaver directly targets Web developers, and Macromedia keeps adding the features hard-core Web geeks request, such as amazing extensibility, tight integration with Flash and Fireworks, and smooth incorporation of server-based Web production tools such as ASP, Cold Fusion, and WebObjects. With GoLive, Adobe builds on its base of print and graphic designers who want to reuse and repurpose their work for the Web. Chances are, both approaches will succeed, as Web developers are a diverse group.

For now, the momentum is definitely behind Macromedia and Dreamweaver 3. Until the next big program comes along, Dreamweaver 3 is the tool of choice for the professional Web site developer.—TOM NEGRINO

**RATING:** ★★★★★ **PROS:** Almost infinitely customizable via JavaScript; practically limitless undos; good integration with Fireworks 3; excellent site-management and collaborative features. **CONS:** None significant. **COMPANY:** Macromedia (800/457-1774, www.macromedia.com). **COMPANY'S ESTIMATED PRICE:** \$299.



# Fireworks 3

MACROMEDIA TIGHTENS GRIP ON WEB GRAPHICS

**F**IREWORKS 3, THE LATEST RELEASE of Macromedia's Web-graphics software, bolsters that company's already strong grip on the market for Web-based creative tools. While previous versions provided useful vector-based drawing tools, Web-optimization features, and automated JavaScript creation, version 3 adds tighter integration with Macromedia's Dreamweaver as well as other improvements that make the package hard to beat.

## Face-lift

Fireworks 2 users will notice a few interface changes as soon as they run the software. The program's tabbed, floating palettes are

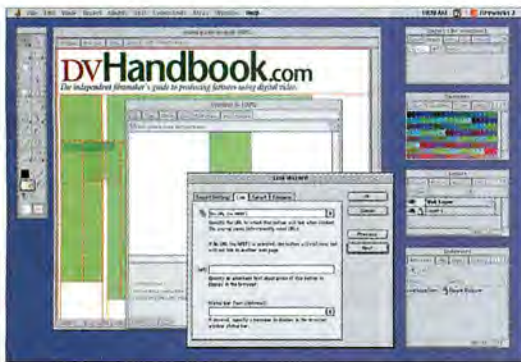

**Magic Links** Fireworks' Link Wizard function makes it easy to add hyperlinks to Web graphics.

better behaved than in previous versions; they now open anchored to the right side of the screen. This and other Adobe Photoshop-inspired palette changes, such as control buttons at the bottom of palettes, make for an interface that's easier to navigate. Unfortunately, other niceties, such as zoom controls that resize a document window while zooming, have been left behind.

Fireworks' palettes still have some odd interface quirks, such as small modal windows that you have to close before you can go elsewhere in the software. Considering that palettes are supposed to operate in a modeless fashion, these controls feel very clunky.

Although Fireworks sports a clean, easy-to-use interface, it can be a little confusing at times, with items and commands spread among menus, palettes, and menus nested inside of palettes.

## New Tools

Fireworks' tools provide a great mix of drawing and painting functions. While the tools are vector based—as in Macromedia FreeHand or Adobe Illustrator—shapes created with the tools can be filled and stroked with painterly textures. With textures and strokes ranging from crayons and chalk to weird alien substances, you can easily create images that look as if they were produced in a painting or image-editing program.

Although Fireworks 3 adds no new tools, it does provide a number of enhancements. As in previous versions, the text tool displays a dialog box for entering and editing text. Version 3 adds controls that let you preview a font before it's applied. You can also resize text blocks as you enter text, and the program now provides three levels of anti-aliasing. However, kerning and leading adjustments aren't displayed in the Text dialog box.

The program's excellent Live Effects feature, which lets you edit or remove effects filters after they've been applied to an object, has been expanded to support third-party Photoshop-compatible plug-ins. Installed plug-ins can be edited and managed through the Effects palette, just like any of Fireworks' built-in effects. Live Effects is one of Fireworks' best features, and in version 3, it's even better.

A new collection of filters lets you perform simple color corrections on any bitmapped image in your document. You can modify contrast, brightness, hue, and saturation and apply standard level and curve adjustments to any bitmapped object. Having these effects built-in is a great time-saver. In addition, Fireworks 3 now lets you choose from standard interpolation methods for scaling bitmapped images.

Finally, Macromedia has added a Photoshop-like History palette for undoing any number of actions. Unfortunately, as in Photoshop, history information is not saved with the document. However, Macromedia has implemented a clever scripting system that lets you save groups of

steps from the History palette as executable scripts. In a program as palette-heavy as this one, this is elegant streamlining.

## Good Behavior

Macromedia has also expanded Fireworks' Java support. As with previous versions, you can attach Behaviors to any object to create rollover buttons and other interface features. Version 3 provides new Behaviors for creating navigation bars and disjointed rollovers (one object's rollover changing the state of another object). Since Fireworks Behaviors are now compatible with Dreamweaver's Behavior features, you can easily create buttons, navigation bars, and animations for simple export to your Dreamweaver projects.

Unfortunately, implementing complex Behaviors requires some of Fireworks' least-intuitive procedures. Disjointed rollovers, for example, involve a complex combination of slicing, layering, and creating different frames. Though the manual provides a pretty good explanation of these features, many processes could stand to be streamlined.

Fireworks' importing and exporting have been improved with the ability to import Illustrator files, Flash files, and layered Photoshop files. Similarly, you can export Fireworks documents as vector illustrations for use in FreeHand and Illustrator or as SWF files for use with Flash.

Fireworks' performance felt just a tad sluggish on our 400MHz Power Mac G3. Opening and previewing documents and dragging filled objects had a slower feel than what we've come to expect from modern painting and illustration packages. Though not slow enough to affect productivity, Fireworks' performance was a bit distracting.

## Macworld's Buying Advice

Although previous versions of Fireworks have offered powerful features, version 3 might even compel longtime Photoshop users to learn a new program. Users of previous Fireworks versions shouldn't hesitate to upgrade.—BEN LONG

**RATING:** **PROS:** Great drawing and effects tools; excellent integration with Dreamweaver. **CONS:** Somewhat complex interface; performance a little slow. **COMPANY:** Macromedia (800/457-1774, www.macromedia.com). **COMPANY'S ESTIMATED PRICE:** \$199; with Dreamweaver, \$399.



**Ultra160 SCSI.  
A better way to  
use your time.**

How frustrating. Just when you're on a creative roll, file saving and scratch disk processing run smack into your train of thought. Not even G4s solve that. But Adaptec has.

Adaptec's PowerDomain® 29160N Ultra160 SCSI card is three times faster than FireWire™. A hundred times faster than USB. And, backward compatibility makes legacy drives and peripherals snap to attention.

Adaptec offers a complete line of SCSI cards from our flagship dual channel Ultra160 PowerDomain 39160 to portable SCSI for your PowerBook®. So instead of worrying about how to get everything done on time, find out how to improve your Mac's performance at [www.adaptec.com/mac](http://www.adaptec.com/mac). And be sure to include Adaptec SCSI with your next Macintosh® purchase.



**SITTING AROUND WITH  
EVERYTHING TO DO?**

*We move the information that moves your world.™*

**adaptec**

©1999 Adaptec, Inc. All rights reserved. Adaptec, the Adaptec logo, the Adaptec tagline and PowerDomain are trademarks of Adaptec, Inc., which may be registered in some jurisdictions. Macintosh and PowerBook are registered trademarks and FireWire is a trademark of Apple Computer, Inc., used under license. All other trademarks used are owned by their respective owners.



# Power Macintosh G4s

NEW SYSTEMS FEATURE UNIFIED ARCHITECTURE

**A**FTER SOME INITIAL CONFUSION, Apple has tidied the Power Mac G4 into a powerful line of systems, all finally with the same architecture. At first, Apple offered high-end systems with the new Sawtooth design and an entry-level system with the older Yikes architecture, based on



and a 10GB hard drive (the system we tested included 128MB of RAM). The standard G4/450 ships with a DVD-RAM drive, 256MB of RAM, a 10/100BaseT Ethernet port, a Zip drive, and a 27GB hard drive—but no modem.

Sawtooth—Apple's internal code name for the design—features faster memory and hard-drive buses; support for up to 1.5GB of RAM; a swift 2X AGP port for the graphics card; an internal FireWire connection and two external ones; and two USB ports, each with a full 12 Mbps of throughput. Sawtooth also includes connections for Apple's AirPort wireless-networking cards.

By comparison, the Yikes architecture supported up to 999MB of RAM; featured a slower, 66MHz PCI slot for the graphics adapter; and drove both USB ports at a combined 12 Mbps, which sometimes caused USB devices to bog down.

Driving the display in Apple's new systems is the ATI Rage 128 Pro video card, an upgrade to the Rage 128 card Apple shipped with previous Power Mac G3 and G4 systems. In addition to offering faster video performance, the card features a Digital Video Interface connector that supports Apple's LCD monitors.

Macworld Lab tests revealed that the new Power Mac G4/350 performs similarly to the Yikes-based G4/350. The biggest improvement is in video performance, no doubt due to the Rage 128 Pro and AGP port. In our Quake II test, the Sawtooth-based G4/350 generated about

55 frames per second (fps), versus 52 for the Yikes-based system.

Not surprisingly, the Power Mac G4/450 proved speedy, especially when running applications optimized to take advantage of the G4's Velocity Engine. For example, the high-end Power Mac ran Adobe Photoshop's Gaussian Blur filter about three times as fast as a G3/400 system and about twice as fast as either G4/350 system. In our Quake II tests, the G4/450 maxed out at 67.4 fps, far outpacing the other systems.

## Macworld's Buying Advice

With the upgraded architecture, you can now buy an entry-level Power Mac G4 with the same speedy system components found in Apple's high-end systems, all for just \$1,599. However, the system's 64MB of RAM is a bit paltry; to take full advantage of that extra performance, invest in more memory. The G4/450 is Apple's fastest system.—DAVID READ

the blue-and-white Power Mac G3. Now Apple is offering 350MHz, 400MHz, and 450MHz models, all with the Sawtooth design (see *Reviews*, February 2000, for a look at the Power Mac G4/400).

The standard Power Mac G4/350 ships with a DVD-ROM drive, a skimpy 64MB of RAM, an internal 56-Kbps modem, a 10/100BaseT Ethernet port,

### Power Macintosh G4/350

**RATING:** ◆◆◆◆ **PROS:** Strong performance; affordable. **CONS:** Skimpy RAM allocation. **COMPANY:** Apple Computer (800/795-1000, www.apple.com). **COMPANY'S ESTIMATED PRICE:** \$1,599.

### Power Macintosh G4/450

**RATING:** ◆◆◆◆ **PROS:** Excellent performance. **CONS:** Expensive. **COMPANY:** Apple Computer (800/795-1000, www.apple.com). **COMPANY'S ESTIMATED PRICE:** \$3,499.

**Macworld**  
LAB TEST

## A Faster 350?

Best results in red. Reference system in italics. Photoshop, Word, and Excel results are in seconds. Bryce and SoundJam results are in minutes:seconds. Quake II results are in frames per second.

	PHOTOSHOP 5.5			WORD 98	EXCEL 98	BRUCE 4.01	SOUNDJAM 1.5.1	QUAKE II 640 X 480
	Gaussian Blur	Unsharp Mask	Lighting Effects	Find/Replace	Recalc	Render Scene	MP3 Encode	
Apple Power Macintosh G4/450 (Sawtooth)	4.1	6.6	4.8	9.7	6.4	19:48	2:11	67.4
Apple Power Macintosh G4/350 (Sawtooth)	8.5	8.1	5.9	12.1	8.1	25:37	2:45	55.2
Apple Power Macintosh G4/350 (Yikes)	9.2	8.5	5.9	12.2	8.0	24:47	2:44	52.2
Apple Power Macintosh G3/400	13.2	12.0	14.4	10.1	6.9	23:20	3:22	50.4

Shorter bars are better. For Quake frame rates, longer bars are better.

### Behind Our Tests

We tested each system with Mac OS 9, a minimum of 128MB of RAM, and virtual memory disabled. We performed Photoshop tests with a 30MB file. We tested MP3 encoding with an audio-CD track that is 9 minutes and 25 seconds in length.—Macworld Lab testing supervised by Gil Loyola





COPPOLA  
DEMILLE  
HITCHCOCK  
KUBRICK  
REINER  
SCORSESE  
SPIELBERG  
STONE  
TARENTINO  
AND YOU?

**On Sale  
Now!**

The **VideoFX™** Video Capture Suite - **Be Creative!**

**CAPTURE**

Grab still photos or video directly from your video tapes or camcorder.

**EDIT**

Cut scenes, add in video footage or still photos, modify to your liking, then save on your computer.

**CATALOG**

Organize all your personal video clips or still photos into albums to be enjoyed for years to come.

**PRINT**

Choose from the FREE photo-templates or create your own and add text or effects and then easily print.

**SHARE**

Save your videos and photos into formats ready to e-mail to others or publish onto the Web.



**GLOBAL VILLAGE**

A brand of Boca Research, Inc.™

10 Years of Cool Macintosh® Products.  
**And We're Just Getting Started...**

Circle 106 on card or go to [www.macworld.com/gefinfo](http://www.macworld.com/gefinfo)



# Tax-Preparation Software

MACINTAX DELUXE, KIPLINGER TAXCUT DUKE IT OUT AGAIN

**G**IVEN THE COMPLEXITY OF OUR tax laws, you need tax software if you want to handle your own returns. Both Block Financial's \$40 Kiplinger TaxCut '99 Deluxe Filing Edition and Intuit's \$50 Quicken MacInTax Deluxe '99 simplify the tax-preparation process while maximizing the amount of money you get to keep. But this year's Kiplinger TaxCut is easier to use and navigate than Quicken MacInTax—and it's less expensive.

(Macworld's policy is to review only final, shipping versions of software. However, due to the time-sensitive nature of these programs, this review was based on late-beta versions.)

Kiplinger TaxCut contains provisions for personal taxes and home offices. MacInTax Deluxe lacks home-office features; for those you'll need the \$65 MacInTax Home and Business edition. The latter offers more help with small-business taxes than does Kiplinger TaxCut, but TaxCut provides almost all the features most home-office users really need.

## The Taxman Cometh

Both programs ask a series of questions designed to gather your tax information, and then they produce the appropriate tax forms. As you answer the questions, you can view any portion of the current form or jump to other forms. You can also enter or edit data directly on the forms if you wish.

One difference between the programs is that TaxCut asks questions in plain English; MacInTax often uses language straight from tax forms. For instance, MacInTax might ask you to choose between Start New Schedule E or Done With Schedule E, or whether you want to start a new Form 1099-MISC. The TaxCut software selects the appropriate form for you.

TaxCut also provides a cleaner interface. The main interview window is divided into three tabbed pages: Prepare, where you enter tax information; Review, where the software checks for missing information or items the IRS might flag; and File, where you print the returns or file electronically.

MacInTax Deluxe forces you to navigate through nine tabs, and the Home and Business edition adds a tenth. And

MacInTax's interview process is not well organized; for example, the business edition asks for information about your *business* office immediately after you enter the percentage of your home used for a *home* office, making it easy to confuse business- and home-office expenses. Other home-office questions come later.

Both programs provide easy access to a table-of-contents window that lets you jump



**At Your Fingertips** Kiplinger TaxCut's Prepare screen lists frequently asked questions about tax topics.

to different parts of the interview. Unfortunately, Intuit has removed the Overview window, a handy navigation aid in last year's edition. Both programs provide commands that let you go back to previous screens, much like the Back button in a Web browser. However, the MacInTax Back command is a text hyperlink that appears in different locations on each page—annoying if you're backing up through several screens.

## First Aid

Help is a big part of any tax-preparation program, and both programs list frequently asked questions—with links to answers—on the right side of the interview window. The questions are context sensitive, changing as you flip through interview pages. Both programs also provide a wealth of built-in reference material, including IRS documentation and tax-planning tips.

However, TaxCut provides more hyperlinked terms and makes it easier to find the help you need. When you click on the Help button, the program almost always brings up an explanation of what you're doing on a particular interview page. MacInTax doesn't always bring you to the information you need. For example, when you click on the Help but-

ton in a window called Get Organized—Deductions, the program displays a Federal Information Worksheet. On the plus side, MacInTax's Guide Me link leads to detailed explanations, such as who qualifies as a dependent, and the business edition provides more built-in tax information than the other programs.

Kiplinger TaxCut and MacInTax Deluxe both include QuickTime movies that illustrate tax concepts and help you learn the software. However, TaxCut includes more movies than MacInTax Deluxe does, and TaxCut's material is better integrated with other help facilities. For example, if you click on the Help button, TaxCut provides more information on the movie's topic. MacInTax Home and Business doesn't include any movies.

Both programs also offer links to their own Web sites for more information. Once again, TaxCut takes you directly to the information you want, and the Tools menu includes an Update TaxCut command that automatically downloads any needed software updates, including those required to complete new tax forms. A similar MacInTax command takes you to a search screen at the Intuit Web site.

## Macworld's Buying Advice

In past years, Quicken MacInTax has been the preferred tax program for Macintosh users. But this year's improvements in Kiplinger TaxCut make it the clear choice for your 1999 tax return. It has a cleaner interface, it's less expensive, and it doesn't require extensive knowledge of IRS forms and schedules.—JOHN RIZZO

### Kiplinger TaxCut '99 Deluxe Filing Edition

**RATING:** ★★★★★½ **PROS:** Easy to use; good tax advice; help when and where you need it. **CONS:** For home and home office only. **COMPANY:** Block Financial (818/779-7223, www.taxcut.com). **LIST PRICE:** \$40.

### Quicken MacInTax Deluxe '99

**RATING:** ★★★★★½ **PROS:** Good, plentiful tax advice; good information on small-business issues. **CONS:** Sometimes difficult to navigate; uses too much IRS jargon. **COMPANY:** Intuit Software (800/446-8848, www.macintax.com). **LIST PRICE:** \$50; Home and Business edition, \$65.



# Give your Mac a multimedia transplant



## ATI XCLAIM VR 128

The ultimate multimedia,  
graphics and TV-Tuner upgrade

One powerful upgrade –  
*many* multimedia features:

- Watch TV on your MAC
- True color 32-bit 3D graphics for incredible gaming action or 3D applications
- Capture motion video and still images from any camcorder or VCR
- Output to TV or videotape
- Play full screen flicker-free video

ATI is the number one graphics supplier to Apple Computer Inc.

Add XCLAIM VR 128, to give a complete multimedia transplant to any MAC with a PCI slot

For more information on ATI's full line of MAC graphics accelerators go to [www.ati.com](http://www.ati.com)



THE  
**POWER**  
OF SPEED



Visit [ati.com](http://ati.com)



Copyright © ATI Technologies Inc. 1999. ATI, ATI XCLAIM VR 128, NEXUS 128 and RAGE ORION are trademarks of ATI Technologies Inc. DARK VENGEANCE™ © 1998, 1999 Reality Bytes, Inc. All rights reserved. Features, performance and specifications may vary by operating environment and are subject to change without notice.



# Color Ink-Jet Printers

EPSON'S STYLUS COLOR 760 AND 860 CHALLENGE HP

**F**EELING THE COMPETITIVE heat from Hewlett-Packard (HP), Epson has improved its ink-jet printer line with faster, sturdier, and quieter offerings. Macworld Lab tested the \$199 Stylus Color 760 and \$279 Stylus Color 860, and concluded that the printers should appeal to SOHO users with USB-equipped Macs. The Stylus Color 760 replaces Epson's Stylus Color 740; the Stylus Color 860 is slightly faster, but otherwise identical to the Stylus Color 760.

## Faster Output

With the Stylus Color 740, you had to print images at 1,440 dpi to get excellent photo quality, and printing at that resolution was a slow process. The new printers feature a number of enhancements, including a smaller droplet size and a more-accurate printhead, that allow them to produce photo-realistic images relatively fast at just 720 dpi. Both printers can also print at a slower 1,440 dpi if you want additional detail.

Epson positions these printers against HP's DeskJet 882C and DeskJet 895C (see *Reviews*, September 1999), but we were more interested in comparing them with a more recently introduced model, HP's \$399 DeskJet 970 (see *Reviews*, January 2000), *Macworld's* Eddy Award winner for Best Printer/Imaging Device (March 2000).

Although the DeskJet 970 remains an excellent general-purpose printer for homes and small businesses, our testing showed that both Epson models offer marginally better photographic quality when printing at the manufacturers' recommended resolutions: 720 dpi for the Epson printers and 600 dpi for the DeskJet 970. The Epson printers' color accuracy especially impressed us, although tweaking the colors is a little tricky because you have so many options, including Apple's ColorSync and Epson's Photoenhance3 color-management systems. Ironically, we got the best results by turning off the color-correction and color-management options. The HP DeskJet 970 produced sharper-looking prints at comparable resolutions, but our jury determined that its

color was a little flatter than the Epson's.

The Epson printers were also somewhat faster than the DeskJet when printing a 26MB, 8-by-10-inch Photoshop image at 720 dpi: the 860 took 4 minutes, 2 seconds; the 760 took 4 minutes, 22 seconds; and the DeskJet 970 took 5 minutes, 2 seconds. However, when printing



Epson Stylus Color 860

plain text, the DeskJet 970 remains the speed champ, printing a 10-page Microsoft Word document in 300-dpi Normal mode in 1 minute, 11 seconds, compared with 1 minute, 49 seconds for the Stylus Color 860 and 2 minutes, 41 seconds for the Stylus Color 760, both at 360 dpi.

Text quality at 360 dpi is adequate for letters to friends or interoffice correspondence, but you should print résumés or formal correspondence at a higher-quality setting. Printing the same Word document at 720 dpi on Epson's photo-quality ink-jet paper, our jury rated text output as excellent. Expect to wait, however: the Stylus Color 860 took 15 minutes, 19 seconds, while the Stylus Photo took 16 minutes, 20 seconds.

## Quiet Ride

Both printers are quieter and more solidly built than their predecessors, although neither is as quiet as the DeskJet 970. Thanks largely to the high-quality servoless stepper motor that moves the printhead, Epson rates the noise level at 42 dB, compared with the 45 dB of the Epson 740.

The cases are constructed of a higher-grade polystyrene that reduces rattle and vibration noise while giving the printers a sturdier and more-pleasing look. The Stylus Color 860 also has a tinted panel through which you can watch the printhead move. However, the 860's printhead, with its slightly faster print speed, is also noisier when printing at high resolutions; at times this was a bit annoying, especially when we were printing on film.

One sad note for users of older Mac systems: Epson, the last holdout to provide serial ports on its printers, has finally abandoned them. If you have an older Mac, you'll need a USB adapter to use these or any other new ink-jet printers. However, both printers work with the \$159 Axis 1440 print server, which provides Ethernet connectivity.

Epson bundles both printers with Polaroid PhotoMax Pro image-editing software and ArcSoft Photoprinter SE photo-layout software. You can choose two additional software titles, such as Diablo or Corel Photo-Paint, for \$7.95 shipping and handling.

## Macworld's Buying Advice

The HP DeskJet 970 remains the best general-purpose printer, but at \$199 (after a \$30 rebate) the Stylus Color 760 is a great value for high-quality photographic printing, especially if you already have a laser printer for producing text documents. The Stylus Color 860 offers marginally faster output, but most users will probably find the speed not worth the extra \$79 outlay.—KEVIN MITCHELL

### Stylus Color 760

**RATING:** **PROS:** Fast, accurate color output; excellent value. **CONS:** No serial port; slows down when printing high-quality text. **COMPANY:** Epson (800/463-7766, www.epson.com). **COMPANY'S ESTIMATED PRICE:** \$199 (after \$30 rebate).

### Stylus Color 860

**RATING:** **PROS:** Fast, accurate color output. **CONS:** No serial port; slows when printing high-quality text. **COMPANY:** Epson (www.epson.com, 800/463-7766). **COMPANY'S ESTIMATED PRICE:** \$279.



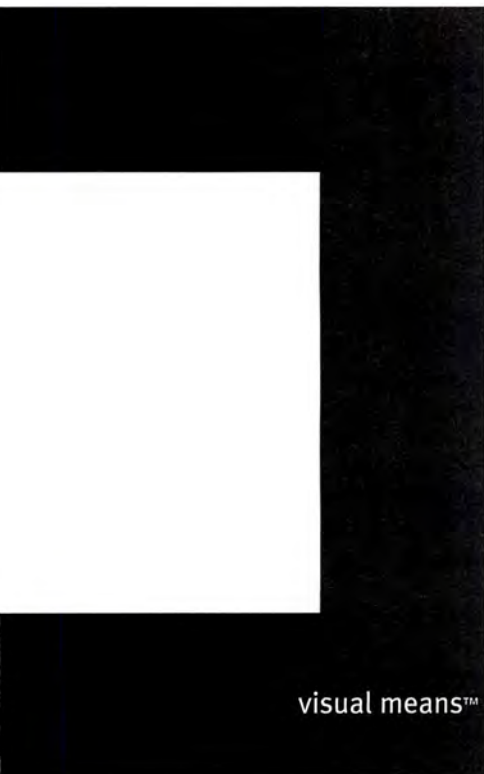

visual means™ Search multiple collections.

**gettyone.com™**

Allsport Concepts

The Bridgeman Art Library

EyeWire

Hulton Getty

PhotoDisc

The Image Bank

Tony Stone Images



# One-Megapixel Digital Cameras

EPSON PHOTOPC 650, OLYMPUS D-450 ZOOM OFFER AFFORDABLE ALTERNATIVES

**T**WO-MEGAPIXEL DIGITAL CAMERAS are now commonplace and will soon be superseded by a new generation of three-megapixel cameras. But it wasn't long ago that one-megapixel cameras overwhelmed us with their image quality. Do you really need more than 1 million pixels in your digital images? If the answer is no—and you want to save some money—the last of the megapixel cameras have just come to market, in the form of the Epson PhotoPC 650 and the Olympus D-450 Zoom. Both cameras produce good-looking pictures, but the Olympus model stands out with higher resolution and a host of useful features, including—true to its name—a 3× optical zoom.

## Positive Image

The PhotoPC 650 captures images at a maximum of 1,152 by 864 pixels; the D-450 Zoom boasts a more impressive 1,280 by 960 pixels. However, we were generally pleased by the image quality of both cameras.

Images produced on the PhotoPC 650 did not display excessive levels of noise or artifacts, but they looked a little soft—enough that you might want to sharpen them in your image-editing program. Images from the D-450 looked better, with sharp detail and low noise levels, requiring minimal editing. Indeed, the noise level equaled that of images from some costly two-megapixel cameras.

Like most inexpensive digital cameras, both models use range-finder designs, meaning you view a scene through a different lens than the one that captures the image; Olympus's C-2500 and D-620L, in contrast, are single-lens-reflex cameras.

## Fit and Finish

The D-450 Zoom is much easier to handle. It sports the same feature and button layout as Olympus's earlier point-and-shoot cameras, and its simple operation is reminiscent of a 35mm camera. The 3× zoom lens is a bit slow to respond to the zoom control, but it gets the job done.

The PhotoPC 650 has a boxy feel, and

the on/off switch is inconveniently placed under the lens. The controls and labeling are not always intuitive; prepare to spend some time with the manual familiarizing yourself with the camera's functions.

Both cameras offer multiple flash options, including forced flash and red-eye reduction. However, if you use the PhotoPC 650 flash when capturing an image, be patient. Once you've pressed the image-capture button, you have to wait up to four seconds for the camera to trip the shutter. By comparison, the



The Olympus D-450 Zoom (left) and the Epson PhotoPC 650.

D-450 is quick on the trigger, whether it's using available light or the built-in flash. And the PhotoPC 650 lacks the D-450's optical zoom, although it does feature 37mm threads for attaching a variety of optional lenses.

## Storage and Connectivity

The D-450 Zoom stores images on Lexar Media SmartMedia cards; the package includes one 8MB card. You can purchase additional cards with a maximum capacity of 32MB; it's unclear whether Olympus will modify the camera to accept the 64MB cards that are expected later this year. The PhotoPC 650 stores images on sturdier—but costlier—CompactFlash cards, also from Lexar. The package includes one 8MB CompactFlash card, on which you can store 30 megapixel images with minimal compression or 47 at medium resolution.

One disappointing aspect of both cameras is the lack of built-in USB ports. Instead, both cameras feature serial interfaces and Mac/PC serial cables; as any

experienced digital-camera user knows, transferring images through a serial cable can be painfully slow. However, the CompactFlash card included with the PhotoPC 650 is USB-enabled; just attach one of Lexar's JumpShot USB cables to the card to transfer images directly to any USB-equipped Mac. But JumpShot does you no good if you have CompactFlash cards that don't support USB.

Olympus offers no USB connectivity at all; users of recent Mac models will need to add a serial interface or, if you want faster transfers, a USB-based SmartMedia reader. Both cameras also include video-out ports for viewing images on a TV set.

## Macworld's Buying Advice

Both cameras are good for capturing images to post on the Web, and you can use them to produce decent-looking prints as large as 8 by 10 inches. At \$499 for the Olympus D-450 Zoom and \$350 for the Epson PhotoPC 650, both are affordable as well. However, the Olympus camera, with its sleek design, higher resolution, and 3× optical zoom, is clearly the better choice, despite its higher price tag; images from the PhotoPC 650 look good, but the D-450 Zoom's images look even better. The biggest knock to the Olympus camera is the lack of USB connectivity; the Epson camera also lacks built-in USB but compensates with its USB-enabled CompactFlash cards.—RICK OLDANO

### Epson PhotoPC 650

**RATING:** ★★★ **PROS:** Affordable; good image quality; uses USB-enabled CompactFlash media.

**CONS:** No zoom; unintuitive design. **COMPANY:** Epson America (800/289-3776, www.epson.com).

**COMPANY'S ESTIMATED PRICE:** \$350.

### Olympus D-450 Zoom

**RATING:** ★★★★ **PROS:** Affordable; excellent image quality; good assortment of features.

**CONS:** No USB interface. **COMPANY:** Olympus America (800/622-6372, www.olympus.com).

**COMPANY'S ESTIMATED PRICE:** \$499.



# Flash websites reach the entire population.



Each day the Flash community grows.

Viewable by over 185 million users,

Flash powers the Web's  
most outstanding sites.\*

So create high-impact Web  
experiences that download  
blazingly fast and put your site  
on the map with Flash.

[www.macromedia.com](http://www.macromedia.com)



DIRECTOR SHOCKWAVE DREAMWEAVER FIREWORKS (FLASH) (FREEHAND) GENERATOR



# G4 ZIF Socket Upgrades

XLR8 AND NEWER CARDS BOOST G3 PERFORMANCE

**N**OW THAT APPLE IS SHIPPING its G4 hardware, the Power Mac G3 that blazed through your applications a year ago might seem a bit long in the tooth. But thanks to the zero insertion force (ZIF) socket in Apple's G3 systems, it's relatively easy to swap in a faster CPU, and developers are racing to offer G4 upgrades for older Macs. First out of the chute are Newer Technology, with its Maxpowr G4

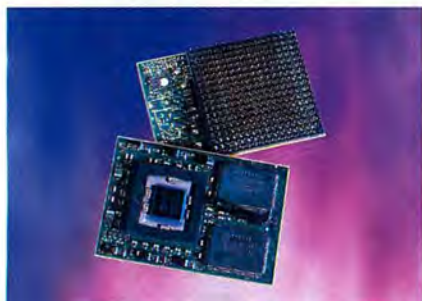

SUZANNE RONDY

400MHz, and XLR8, with the 400MHz Mach Speed G4z. The two cards offer comparable performance, providing a substantial speed boost when running 3-D-rendering software or AltiVec-enabled applications. However, you'll likely see only modest improvements when running everyday business applications or graphics-intensive computer games. Both upgrades work with Apple's full range of Power Mac G3 systems.

Macworld Lab tested the upgrades in a 300MHz blue-and-white Power Mac G3.

Results were predictable (see "400MHz ZIF Upgrades"). When running applications that had been enhanced to take advantage of the G4's Velocity Engine (Apple's brand name for Motorola's AltiVec G4 extensions), both upgrades provided huge performance improvements to our test system. Adobe Photoshop's Lighting Effects plug-in ran more than three times as fast with an upgrade, and the Gaussian Blur filter was about twice as fast.

When encoding MP3 audio with Casady & Greene's SoundJam 1.5.1—another AltiVec-enabled program—the CPU upgrades almost doubled the performance of our test system. You can also expect a speed boost when running CPU-intensive 3-D-rendering tasks; a Bryce scene that took about 31 minutes to render on the G3 system rendered in about 23 minutes when we added an upgrade.

However, other performance gains were minimal. For example, the upgrades shaved just a few seconds off a Microsoft Word find-and-replace operation, and when running Quake II, they provided only a modest boost in frame rate. The latter shouldn't be surprising, since 3-D-video playback performance is largely determined by the graphics controller, not the CPU.

The CPUs are a cinch to install; you just plug the card into the ZIF socket and add a system extension. Although there were early reports that blue-and-white G3 systems would not accept G4

upgrades, the extensions appear to solve any compatibility issues; we encountered no unusual system crashes or other anomalies after installing the CPU upgrades.

## Macworld's Buying Advice

Both upgrades work as advertised, bringing G4 speeds to Apple's previous-generation G3 Power Macs. But does it make sense to shell out \$800 or \$900 for a CPU card when you can have a spanking-new G4 system for \$1,599? If you have a beige Power Mac G3 and a big investment in SCSI peripherals, the answer might be yes, because getting a new G4 system also means junking those old peripherals and making the move to USB and FireWire. However, if you've already made the move to the new interfaces, you're probably better off investing in a new G4 system—at least for the time being. The CPU-upgrade business is highly competitive, and you can expect prices to fall as other vendors offer their own G4 upgrades.—STEPHEN BEALE

### Maxpowr G4

**RATING:** **PROS:** Easy to install. **CONS:** Expensive. **COMPANY:** Newer Technology (316/943-0222, www.newertech.com). **COMPANY'S ESTIMATED PRICE:** \$799.

### Mach Speed G4z

**RATING:** **PROS:** Easy to install. **CONS:** Expensive. **COMPANY:** XLR8 (888/957-8867, www.xlr8.com). **COMPANY'S ESTIMATED PRICE:** \$879.

Macworld  
LAB TEST

## 400MHz ZIF Upgrades

Best results in red. Reference system in italics. Photoshop and Word results are in seconds. Bryce and SoundJam results are in minutes:seconds. Quake II results are in frames per second.

	PHOTOSHOP 5.5			WORD 98	BRYCE 4.01	SOUNDJAM	QUAKE II
	Gaussian Blur	Unsharp Mask	Lighting Effects	Find/Replace	Render Scene	MP3 Encode	640 ∞ 480
XLR8 Mach Speed G4z	6.7	10.3	5.8	18.2	22:52	2:29	18.5
Newer Maxpowr G4	6.9	9.7	6.1	19.3	22:31	2:37	18.7
Apple Power Macintosh G3/300*	14.7	15.9	19.5	21.4	31:01	4:19	17.2

\*Previous G3 architecture.

Shorter bars are better. For Quake frame rates, longer bars are better.

### Behind Our Tests

We tested both cards in a Power Macintosh G3/300 with Mac OS 9, a minimum of 128MB of RAM, and virtual memory disabled. We performed Photoshop tests with a 30MB file. We tested MP3 encoding

with an audio-CD track that was 9 minutes and 25 seconds in length.—Macworld Lab testing supervised by Jeffy K. Milstead





What the %\*#@\* is this?

*Without MacLinkPlus® Deluxe, you'll never know.*



Is it a critical spreadsheet file? Is it a photo of your cousins at the Grand Canyon? Who knows? Certainly not you... because you can double-click it 'til your finger falls off, but it just won't open. Why? Maybe it originated on a Windows® machine, or was compressed, or was created with a program you don't own. Whatever the case, you need *MacLinkPlus Deluxe 11*. Over 10 million users already rely on it to open, decompress, and convert documents. So when a file arrives on your Mac, you double-click it, it opens. End of story.

*MacLinkPlus Deluxe is one of several Mac, PC and Palm Organizer programs from DataViz, the compatibility experts. Buy or upgrade at our Web site, or at many software retailers, including:*

**DataViz®**  
**Compatibility. Instantly.**

[www.dataviz.com/MLPlus](http://www.dataviz.com/MLPlus)

1-800-270-0030 x216

**COMPUSA**  
THE COMPUTER CONNECTION

**Fry's**  
ELECTRONICS

**MICRO CENTER**  
THE COMPUTER CONNECTION STORE

Circle 142 on card or go to [www.macworld.com/getinfo](http://www.macworld.com/getinfo)



# Font-Management Software

FONT RESERVE AND FONTAGENT KEEP YOUR FONTS TOGETHER

**M**ACS HAVE COME A LONG WAY over the years, but keeping track of your fonts can still be a challenge. Insider Software's FontAgent 8 and DiamondSoft's Font Reserve 2.5 both aim to simplify the way you use your fonts. They may sound like competitors, but the programs complement each other, making a strong argument for having two font utilities.

## Clean Those Files

FontAgent 8, the simpler of the two programs, scans your hard disk or network, analyzing, repairing, and organizing all fonts into user-designated folders or suitcases. It will not activate your fonts for use in specific applications but provides a good starting point for other font managers that do provide activation, such as Font Reserve, Extensis Suitcase, and Adobe ATM Deluxe.

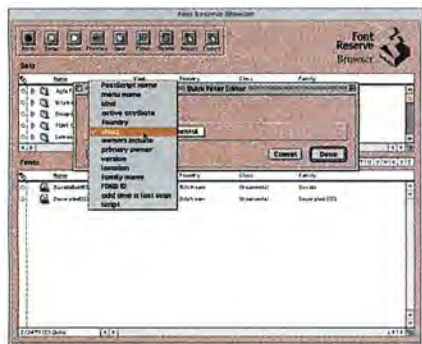

**Font Filters** Font Reserve lets you sort and filter fonts using a variety of criteria.

FontAgent's main window consists of three large buttons, with clear explanations of their respective tasks. The first button, Set Optimization Options, tells the program to locate all fonts in the system. Once it finds them—which it does rather quickly—you can choose from several optimization options. In addition to removing duplicate or incomplete fonts, you can get rid of unneeded bit-mapped versions of the typefaces. Removing all bitmaps larger than, say, 12 points, saves an astounding amount of hard-disk space: on our system, we reduced an unwieldy 350MB type library to 120MB. FontAgent also attempts to repair any corrupted fonts it locates.

The second button, Set Organization, lets you set options for collecting and sorting fonts. You can keep them in their existing suitcases; move them into new, lean, alphabetized suitcases; or move them into designated folders. You can also add extensions to each suitcase that identify its contents as a Type 1 or TrueType font. The process worked without a hitch, but we would feel safer if the program let you copy the fonts—keeping them in their original locations—in addition to moving them.

The third button, Problem Fonts, lets you direct any irreparable corrupted fonts into a separate folder. You can then delete the font or reinstall it from the original disk.

## Get Organized

Once you've optimized your fonts, a font-organizing utility can keep track of them. Our personal favorite is Font Reserve; version 2.5 is an update to a nearly flawless font-management tool.

The first change you notice is not part of Font Reserve at all, but rather the addition of a free, bundled version of Action WYSIWYG, a \$30 utility that reorganizes the Mac font menu into logical groups, much as Adobe Type Reunion does. The package also includes 40 Bitstream fonts.

The program itself scans your system for fonts and stores them in a database. You then run the Font Reserve Browser to view the fonts, using filters to sort and access the typefaces by a variety of parameters. For example, you can limit the display to ornamental faces by clicking on the Filter button and defining a search.

But the most useful feature is activation—just drag and drop fonts into sets you can then activate and deactivate as needed. Font Reserve 2.5 activates fonts even faster than before, and with less hassle than other utilities. The previous version could activate fonts in many applications merely by opening documents that contained those typefaces. The update adds a technology called Font Sense that stores the exact font specification within a QuarkXPress or Adobe Illustrator document, ensuring that the document will open with the same version of the font as before. DiamondSoft says it's working with other vendors to support Font Sense.

The update adds full compatibility with Mac OS 9; if you have your Macintosh set up for multiple users, each one can have a separate Font Reserve database. DiamondSoft has also enhanced Font Reserve's Specimen Book feature: sample fonts print faster than before, and the program doubles the number of specimen templates to 20.

At \$120 for the CD-ROM version, Font Reserve is a little pricey. But you can purchase a download-only version for \$90, and the bundled fonts and Action WYSIWYG utility certainly sweeten the pot. Upgrades from previous versions sell for \$40—a good deal considering that Action WYSIWYG alone sells for \$30.

## Macworld's Buying Advice

Font Reserve is the smartest, most comprehensive font-management application on the market. This update adds only a few new functions, but the program still raises the bar on other font-management packages. FontAgent 8 is a great complement to Font Reserve or any of the other font-activation utilities. Although Font Reserve's filtering capabilities duplicate some of the font-organizing functions in FontAgent, the latter's ability to streamline font files and repair corrupted fonts makes it a worthy addition for any Macintosh user who handles type on a frequent basis.—ANDREW SHALAT

## FontAgent 8

**RATING:** **PROS:** Easy interface; streamlines font files. **CONS:** No option for copying font files. **COMPANY:** Insider Software (800/700-6340, www.insidersoftware.com). **COMPANY'S ESTIMATED PRICE:** \$70; network edition, \$160.

## Font Reserve 2.5

**RATING:** **PROS:** Comprehensive font management; fast activation. **CONS:** None significant. **COMPANY:** DiamondSoft (415/381-3303, www.fontreserve.com). **COMPANY'S ESTIMATED PRICE:** \$120; download-only version, \$90.



# "I wanted the best protection available and APC delivered."

- Fred Lugano, weatherization.com, Vermont

## 8 million computer users can't be wrong about APC power protection

Personal computer users across the country recognize APC as a leader in power protection. Now, home users are finding multiple uses for APC products. Some use their APC to run a television or small refrigerator during a disaster. Others will use their APC Uninterruptible Power Supply (UPS) as a "power bridge" to give them enough time to get their power generators started. Still others will use APC to protect sophisticated audio and visual equipment from damaging electrical surges.

Business users enjoy the dependability of APC, the \$25,000 equipment protection guarantee that comes with all APC UPSs, and the Lifetime Guarantee<sup>1</sup> that comes with all APC surge protection products.

Visit your reseller or the listed retailers and try one today!



APC provides legendary surge protection for all your equipment needs.



APC Back-UPS Pro<sup>®</sup> 500:  
"APC's latest plugs into a USB port, making it completely painless to protect your PC from power snafus and electrical spikes."  
- PC Computing 4/99

### An APC UPS gives you:

- Enough outlets to protect your computer plus displays, printers, scanners and more
- Emergency battery power for continuous uptime through brief power outages to help save your data
- Telephone/network surge suppression to maintain your online connection

- Auto-shutdown software which saves your files and data, even when you're away from your computer

### APC safety and reliability benefits:

- User-replaceable batteries reduce service costs
- Easy overload recovery
- Site Wiring Fault indicator

- Audible and visible alarms alert you to power events as they occur
- \$25,000 equipment protection guarantee (U.S. and Canada only)  
<sup>1</sup>See policy for details
- "Best in Class" longest runtime guarantee (5-40 minutes)

You can find APC power protection products at these stores or visit <http://promo.apcc.com> and click on "how to buy" to find your nearest reseller.



**APC**  
Legendary Reliability™



## Enter to win the APC Home Power Protection Package.

Enter to win APC's legendary power protection for your entire home, home office or small business, a \$3000 value! All entrants will also receive an "Are You at Risk" Kit.  
(See APC's Web site for complete promotion details)

Enter now: Visit <http://promo.apcc.com> Key Code r426z • Call 888-289-APCC x8823 • Fax 401-788-2797

©2000 American Power Conversion. All Trademarks are the property of their owners. APC3E9CF-US • PowerFAX: (800)347-FAXX • E-mail: [apcinfo@apcc.com](mailto:apcinfo@apcc.com) • 132 Fairgrounds Road, West Kingston, RI 02892 USA



# Kai's Power Tools 6

ALL-NEW ADOBE PHOTOSHOP PLUG-INS

**M**OST ADOBE PHOTOSHOP users have encountered MetaCreations' Kai's Power Tools, the popular collection of special-effects plug-ins known by its initials, KPT. Over the years, MetaCreations has offered infrequent upgrades—spruced-up versions of the old plug-ins, along with a handful of new ones. But with KPT 6, MetaCreations has changed its approach: rather than updating the same software, the company has released a set of new filters to be sold alongside KPT 5, the previous—and now concurrent—version. (At press time, MetaCreations had recently announced its intention to divest itself of much of its graphics software, so it's likely that the KPT plug-ins will eventually be offered by a different company.)

Like its predecessors, KPT 6 is a mix of some useful tools and some silly effects. Though the program's interface is not as obtuse as those of previous versions, some users may find that it has annoying characteristics.

## Staying Sharp

KPT 6 consists of eight new plug-ins that work with Photoshop, MetaCreations Painter, and other image-editing programs that support the Photoshop plug-in architecture. As in previous KPT versions, each filter consumes the entire Mac screen with its own un-Mac-like interface. While it looks cool, this "modal" interface can be irritating. For example, if you want to edit a document while viewing a reference image in the background, you're out of luck.

We found the most useful new filter to be Equalizer, which lets you selectively sharpen different parts of an image using controls resembling those of an audio graphic equalizer. One Equalizer mode, Bounded Sharpen, prevents halos from appearing around high-contrast edges. The manual recommends using Equalizer with downsampled images, but we found it to be a good tool for many sharpening chores.

LensFlare, a good replacement for Photoshop's simple Lens Flare filter, offers an impressive degree of control and high-quality results. However, lens flares are so overused that we can't get too excited about this plug-in.

KPT 6 also includes a number of filters for creating textures and odd surface effects. Materializer, for example, treats an image as



**A New Perspective** With Kai's Power Tools 6's Projector filter, you can create still or animated perspective distortions by dragging the corners of your selected image.

a height map, where darker areas are higher (or lower, depending on your settings) than lighter areas. Materializer does all the work of adding highlights and shadows to make your 2-D image stand out in relief, giving you full control over light position, highlighting, and reflections. This plug-in is much more convenient than a 3-D package for creating bump-map and embossing effects, but its usefulness depends on the kinds of images you like to create.

Ideal for creating still or animated water textures—as well as cool abstract patterns—Turbulence lets you distort an image into patterns that resemble pond ripples. This plug-in is beautiful to watch, and it's a good tool for videographers and 3-D animators.

KPT's Reaction filter lets you create complex "organic" textures from underlying images. Similar to Photoshop's Stamp filter, it performs a series of actions that would otherwise require multiple steps and several layers.

And the Projector filter provides a simple interface for applying perspective to an image. It maps an image to a plane that you can tilt by dragging corners.

## Gel or Goo?

The Goo filter incorporates some of the features in Kai's SuperGoo. The best smearing and smudging tool around, Goo lets you create realistic distortions or wild abstractions simply by dragging a tool across an image. As with its stand-alone predecessor, you can also use Goo to create animations that you can export as QuickTime movies.

Gel lets you paint on an image using a thick, viscous goop that looks like tree sap or hot glue. In addition to a good assortment of tools for cutting, pushing, and pulling, Gel includes useful lighting, tinting, and reflection controls.

Finally, KPT 6 includes two extra plug-ins previously sold by Rayfect, both of which use more-conventional interfaces. SceneBuilder (formerly known as Rayfect Photo Tracer) provides a tidy 3-D scene-building environment for use in Photoshop. You can import models, position and light them, and then render a finished scene. Though no substitute for a full-blown 3-D package, SceneBuilder is a great shortcut for creating simple logos and renderings.

SkyEffects (formerly known as Rayfect Four Seasons) lets you create horizons and skies, complete with clouds, moons, rainbows, and sunsets. While a far cry from the beautifully ray-traced skies in MetaCreations Bryce, SkyEffects is a great way to quickly create an environment map for a 3-D program, or a simple sky for a backdrop.

## Macworld's Buying Advice

KPT's Equalizer, Turbulence, Goo, and Projector filters alone are worth KPT 6's \$150 price tag. You probably won't find yourself using these filters every day, but given their popularity, you can expect to see artwork that obviously incorporates their effects. We're a little nervous recommending a product that's likely to be sold off by its current developer, but with KPT's successful track record, the program is likely to find a happy home with a different software publisher.—BEN LONG

**RATING:** ★★★★★ **PROS:** All-new Adobe Photoshop filters, some more useful than those in previous versions. **CONS:** Nonstandard interface. **COMPANY:** MetaCreations (800/846-0111, www.metacreations.com). **COMPANY'S ESTIMATED PRICE:** \$150.



# You think the Internet is safe. Think again...



## NetBarrier. The first Internet security solution for Macintosh.



All Macs connected to the Internet (dialup, DSL, cable-modem) are exposed to hackers. Whether you are a home user or a professional user, your data interests them. That's why you need a security solution that only NetBarrier can provide.

### Personal Firewall

NetBarrier protects and monitors all incoming and outgoing data. A customized mode allows you to create your own defense rules, thereby offering the most secure level of protection.

### Antivandal

NetBarrier blocks all attempts to break into your Mac, detects wrong passwords and logs vandal attacks for complete protection. Moreover, it has an alarm to inform you of every intrusion attempt.

### Internet filter

NetBarrier analyzes data as it leaves your computer and prevents unauthorized exporting of private information such as credit card numbers, passwords, sensitive data and more...



Now sold at  
**ClubMac**  
www.clubmac.com

**Outpost.com**

Now available for resellers through  
**pinacor**  
1.800.PINACOR / www.pinacor.com

**www.intego.com**



Mac and the Mac logo are trademarks of Apple Computer, Inc., registered in the U.S. and other countries. Outpost.com™ is a trademark of Cyberian Outpost, Inc. All other trademarks belong to their respective owners. Digital Imagery® copyright 1999 PhotoDisc.

Circle 85 on card or go to [www.macworld.com/getinfo](http://www.macworld.com/getinfo)



Expert Analysis  
of the  
Inside Story

### Norton AntiVirus 6.0

INCREMENTAL UPDATE TO UTILITY

**V**ENDOR-INDUCED PARANOIA aside, the reality of today's Net-connected world is that every networked computer—Mac and PC alike—is susceptible to viruses. Even careful computer users may have sloppy friends who unwittingly propagate malicious wares. Consequently, antiviral software is a necessity. For most Mac users, this means Symantec's Norton AntiVirus (NAV), currently the only credible antivirus software for the Mac.

Although it remains a solid protection tool, the latest incarnation—NAV 6.0.1—is a ho-hum upgrade. The main addition, LiveUpdate, automatically downloads software updates and information about new viruses, vastly improv-

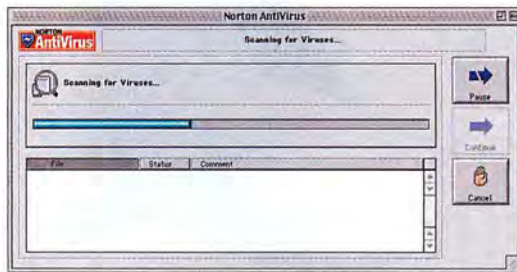

Where's the Info? NAV's poorly designed main window doesn't convey useful information during a scan. It offers no indication of which file it's scanning or how many files remain.

ing on the automated updating feature in the previous version. Otherwise, little has changed since NAV 5.0 (see *Reviews*, March 1999).

#### Server-Unfriendly

NAV 6.0.1 consists of the main application, an autoprotect extension, and the new LiveUpdate utility. The extension, which scans your system for potential viruses, behaves just as in previous versions. You can configure it to scan incoming files and alert you if it detects any suspicious activity; otherwise it lies relatively dormant. You also need the extension if you want to perform scheduled virus scans.

Unfortunately, the autoprotect extension is not a viable option for servers. Virus scans slightly slow overall server performance, and an alert stops an entire Mac system in its tracks—this may be useful on a typical desktop Mac, but it's lethal in a server environment. Considering the large numbers of AppleShare servers sold

over the years and the various e-mail and Web-server packages available for Mac OS, it's surprising that Symantec provides no Mac server support.

Like the autoprotect extension, the main NAV application remains largely unchanged. Although this version does have some under-the-hood performance improvements, the user interface is really showing its age. For example, when you're scanning a Mac system, NAV offers no useful feedback: the status bar marches from left to right, but you can't tell which file or folder the software is scanning or when it might be finished.

NAV's handling of compressed files is especially opaque. The program skips compressed files when it encounters them and then scans them all at the end of the process. If you interpret a full status bar as meaning the program is done scanning, you could be in for a rude surprise if you have many large archives on your disk.

Finally, NAV's QuickScan, which speeds performance by skipping previously scanned files, doesn't recognize previously scanned archives. Instead of skipping the archives, as it does with uncompressed files, QuickScan scans all of them each time.

#### Macworld's Buying Advice

With NAV's primary competitor, Dr. Solomon's Virex, apparently in limbo, NAV is the only reputable Mac antivirus package, and Symantec seems to know this. Instead of adding innovation, Symantec took the conservative approach and made only modest changes to the previous version. That said, NAV 6.0.1 is a solid package backed by a respected antivirus-research organization. The one-year subscription to virus-information updates, coupled with the new LiveUpdate feature, makes it a worthwhile addition to every utility set. We just wish Symantec would make this a more usable package.—STEPHAN SOMOGYI

**RATING:** ★★★ **PROS:** Fast repeat scanning; improved LiveUpdate. **CONS:** Poor archive handling; uninformative interface; not server-friendly. **COMPANY:** Symantec (800/441-7234, www.symantec.com). **COMPANY'S ESTIMATED PRICE:** \$70.



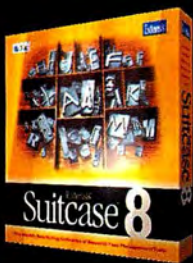
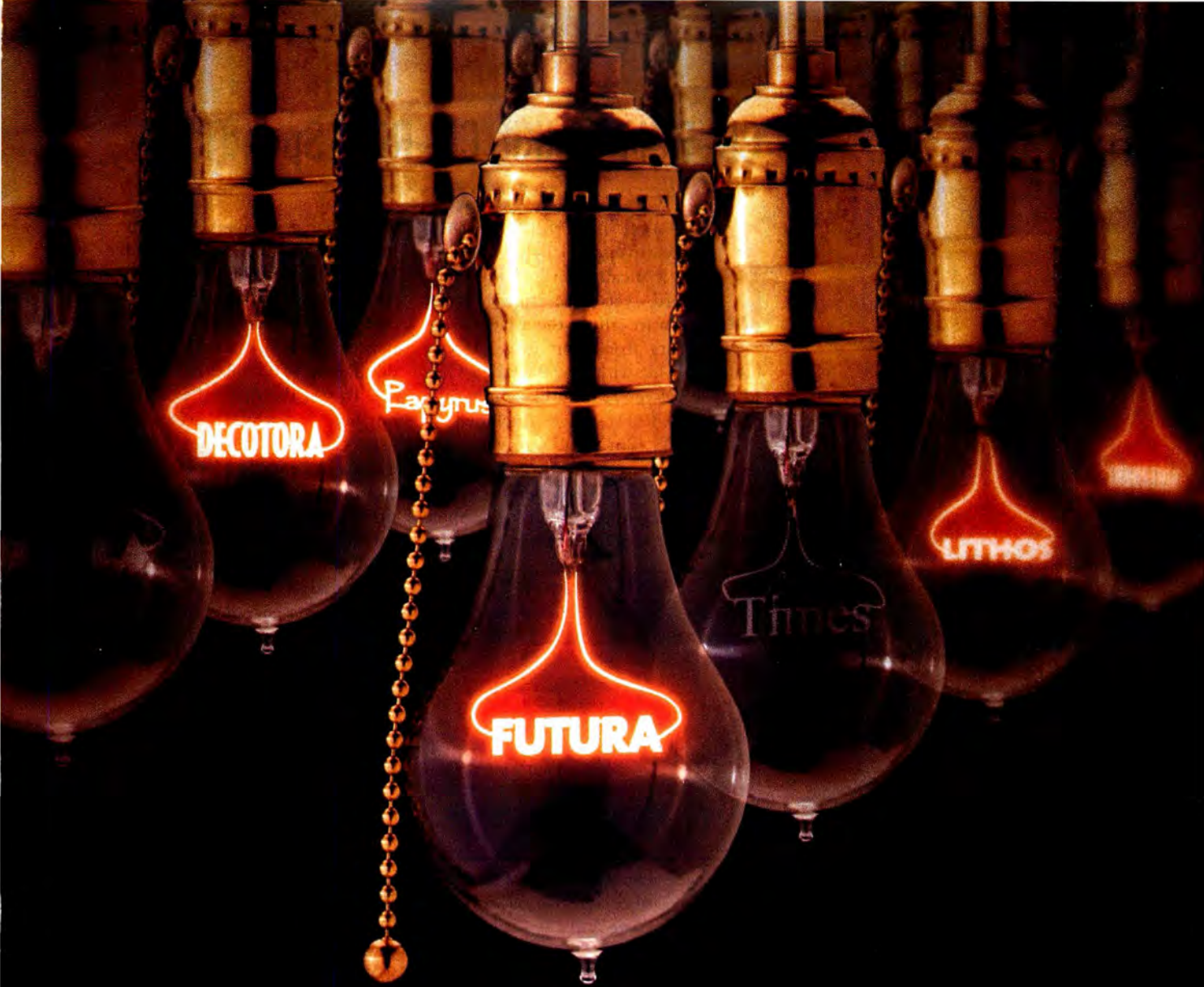

Suitcase 8.2 includes a free copy of Suitcase Server with three connections. Now small workgroups can automatically coordinate their fonts.

 OS 7.5, 5- 9.0.

## Simple brilliance

*Some ideas are timeless. Take the light bulb. It's easy to install, and even easier to use. Extensis Suitcase takes a cue from the humble bulb when it comes to font management. It couldn't be easier to install and use. You turn fonts on, and you turn fonts off. You can easily organize fonts, see what they look like, and help your system run faster and crash-free. Your Macintosh has a bright new future with Suitcase.*

Find out more

Extensis Suitcase

[www.extensis.com/mw](http://www.extensis.com/mw)

800.796.9798



Extensis Products Group, 1.800.803.6921, 503.274.2020, Fax: 503.274.0530. Extensis Europe, The Netherlands, Phone +31-30-24-75050, Fax: +31-30-24-12039. © 1999 Creativepro.com, Inc. All rights reserved. Extensis and the Extensis logo are trademarks of Creativepro.com, Inc. Suitcase is a trademark of Symantec Corporation. Menu Fonts is a trademark of DUBL-CLICK Software, Inc. Suitcase XT developed by NRG Software, LLC, © 1999. Macintosh and the Macintosh OS logo are trademarks of Apple Computer, Inc., used under license. Other trademarks are the property of their respective owners.

SUMWNA021299

**Circle 14 on card or go to [www.macworld.com/getinfo](http://www.macworld.com/getinfo)**



If you buy it,



will it work?



MacBuy.com

Make sure you know.

The Macworld Buyer's Guide  
www.macbuy.com

## CD-ROM ToolKit, CD-ROM SpeedTools

NON-APPLE CD DRIVERS BEST FOR OLDER MACS

**L**IKE HARD-DISK DRIVERS, SOFTWARE drivers for CD-ROM devices are typically neither seen nor heard—yet these crucial bits of software allow the Mac OS to retrieve data from your drive. If you bought a Mac with a preinstalled CD-ROM drive, you're most likely using the Apple CD-ROM driver included in the Mac OS. But Apple's driver won't support most external drives and won't let you use CD-R or CD-RW burners to read discs. In addition, you can't use the Apple CD software with the drives in most Mac

affordable price tag. While the driver includes a multiple caching scheme—just like ToolKit—for improved performance, it keeps things simple with just two tunable options, neither of them disc-specific. The default setting for one option lets the driver decide how to optimize performance.

To test the drivers' performance in our blue-and-white Power Mac G3, we used Casady & Greene's SoundJam to extract and encode a lengthy music track from a CD. The Apple and SpeedTools drivers offered similar performance, but we found that ToolKit 4.0.1 doesn't allow SoundJam to extract and encode in a single pass. As a result, users face considerably longer encoding times because the software must first extract the audio data from the disc. This omission is surprising in ToolKit, a product that should be quite mature by now.

### Macworld's Buying Advice

If your CD-ROM drive works with the Apple driver, stick with that. But if Apple's driver doesn't recognize your CD-ROM drive, Intech's CD-ROM SpeedTools is the better choice. It costs half as much as FWB's package, it behaved well in our testing, and unlike ToolKit, it supports asynchronous operation for faster performance. SpeedTools is also thrifty with system resources, and Intech's policy of free future upgrades for SpeedTools customers makes the product an even better bargain.—STEPHAN SOMOGYI



**Just Enough and No More** CD-ROM SpeedTools' control-panel interface provides all you need to tune CD-ROM performance.

clones. FWB's CD-ROM ToolKit 4.0.1 and Intech's CD-ROM SpeedTools 4.1 let your Mac work with devices that Apple's stock drivers don't support.

### In with the New

The latest incarnation of FWB's ToolKit looks and works just like its predecessor, version 3.0. The only noticeable difference is the inclusion of limited editions of Audion, an MP3 player, and N2MP3, an MP3 encoder. ToolKit improves CD performance through multiple caching schemes: you can set up static and dynamic RAM caches, and even set them for specific CDs. ToolKit includes performance-tuning profiles for specific CD-ROMs, but it lists mostly old titles, and the profiles are of questionable value as they're appropriate only for data CDs—audio CDs don't benefit from caching drivers. An automatic tuning system would have been a good idea.

Intech's SpeedTools, a relative newcomer, features a svelte interface and an

### FWB CD-ROM ToolKit 4.0.1

**RATING:** ★★★½ **PROS:** Bundled with light versions of MP3 applications. **CONS:** Expensive; doesn't support asynchronous I/O on ATAPI drives. **COMPANY:** FWB (800/581-4392, www.fwb.com). **COMPANY'S ESTIMATED PRICE:** CD-ROM, \$80; download, \$70.

### Intech CD-ROM SpeedTools 4.1

**RATING:** ★★★½ **PROS:** Straightforward interface; good performance; inexpensive. **CONS:** Audio CD player has fewer features than Apple's. **COMPANY:** Intech (www.intechusa.com). **LIST PRICE:** \$35.



# ViewSonic® will improve your image with... **PerfectFlat® Technology**



PF790

The new ViewSonic PF790 19" (18.0" viewable) monitor has a .25mm - .27mm super fine aperture grille pitch and a maximum resolution of 1600 x 1200. The PF775 17" (16.0" viewable) monitor has an ultra fine .25mm aperture grille pitch and 1600 x 1200 maximum resolution. Both monitors utilize **PerfectFlat** technology designed to provide your Visual Computing™ experience with edge-to-edge distortion free images.

*For more information on the company that's won over 600 industry awards, visit our website at: [www.ViewSonic.com/pf790](http://www.ViewSonic.com/pf790)*

**At ViewSonic, we offer the #1 best selling monitors and flat panel displays in the USA\*.**

Buy with confidence from the company that's won over 600 industry awards. Our warranty covers 3 years parts labor. Plus 24-hour customer service, 7 days a week.

**The Visual Technology and Communications Company™**





Get everything  
you're looking for:



www.macworld.com/getinfo

Macworld's  
Reader Service

"Get Info" with options! Now you can get information on all the products and services you see in *Macworld*. And get it faster. Simpler. Better. Easier. All you need to do is visit one Web site:

www.macworld.com/getinfo

Then select the products, the categories or advertisers for whom you want to receive information. That's it. You can have the information delivered to you by e-mail, snail mail or even telephone. Or you can click on a link that will take you to the vendor's Web site in one easy step.

PLUS! In this issue, the return of the hard card! A traditional perforated card that allows you to circle your product-info choices as you read *Macworld* on the train, on the plane or where-ever you are. Then drop the card in the mail and it's on the way!

Macworld

## Network Storage Devices

INSTANT GIGADRIVE AND SNAP SERVER 2000 SIMPLIFY DATA SHARING

**W**HAT A SHAME—WASTING AN entire Mac only on file sharing. That's just the problem network storage devices address—they free up your Macs for real computer work by providing the function and performance of a 10/100BaseT Ethernet file server in a self-contained box requiring minimal administration. Linksys's EtherFast 10/100 Instant GigaDrive and Quantum's Snap Server 2000 bring this technology to Macintosh networks in a big way with 20GB and 40GB capacities,



Quantum's Snap Server 2000

respectively. Both servers also let you share files with Windows users.

About the size of a large modem, the single-drive Linksys GigaDrive has three simple connections: power, Ethernet, and printer. The printer connection lets you attach a PC-style parallel-port printer to operate as a network output device.

A brief user's guide tells you everything you need to know to set up the GigaDrive—if you're a Windows user. Mac users must call Linksys tech support to get essential installation details, such as the server's default IP address. Linksys says it will remedy this shortcoming in the near future.

Quantum's somewhat bulkier dual-drive Snap Server is much more Mac-friendly, with a comprehensive user's guide and Mac-specific quick-start instructions. The Snap Server lacks print-serving capability but has other useful functions not found on the GigaDrive: a built-in Web server for hosting users' Web sites, and Network File Sharing (NFS) support for Unix interoperability. You have the option of configuring its dual disk drives as either RAID 0 (striping) to combine the drives in a single large

logical drive, or RAID 1 (mirroring) to provide enhanced fault tolerance.

Both servers have common features: 10/100BaseT Ethernet, Web-based administration, Dynamic Host Configuration Protocol (DHCP) IP-address serving, e-mail notification of problems, and support for multiple users and groups. With both servers, you use a Web browser to set up individual user accounts and passwords, user groups, and shared folders.

The Snap Server supports AppleShare IP, which lets you share content across routers and over the Internet. Among Macintosh file-sharing protocols, the GigaDrive supports only AppleTalk, which is much slower than TCP/IP over Ethernet. In our tests on a 100BaseT LAN, this difference proved large: copying a 256MB file to the Snap Server was *ten times* as fast as copying the same file to the GigaDrive: 5 minutes versus 50.

### Macworld's Buying Advice

The Instant GigaDrive's low price and built-in printer server make it an attractive choice for SOHO users, for whom speed is usually less important than cost and convenience. However, for larger networks with multiple users, the GigaDrive is too confining. If money is not the deciding factor, the faster, higher-capacity Snap Server 2000 is a better product: its Web serving, NFS, and multiuser features help it fit into nearly any network neighborhood.—MEL BECKMAN

### EtherFast 10/100 Instant GigaDrive

**RATING:** ★★★ **PROS:** Inexpensive. **CONS:** Incomplete documentation; no AppleShare IP; no RAID disk protection; no Web serving; slow. **COMPANY:** Linksys (800/326-7114, www.linksys.com). **LIST PRICE:** \$649.

### Snap Server 2000

**RATING:** ★★★★½ **PROS:** AppleShare IP support; RAID disk protection; fast. **CONS:** No external disk-capacity or network-speed indicators. **COMPANY:** Quantum (888/343-7627, www.snapserver.com). **LIST PRICE:** 20GB, \$999; 40GB, \$1,799.



\*\*\*\*\*  
**XY Stitch** Scanning  
Technology

\*\*\*\*\*  
Powerful **SmartSet**  
Application Feature

\*\*\*\*\*  
Affordable  
**Scitex Quality**

**EverSmart Jazz**  
scanners incorporate unique,  
**INNOVATIVE** technologies  
that assure the highest  
**IMAGE QUALITY.**

A host of built-in automated  
tools make it **EASY** to achieve  
print-ready quality from  
day one.

Moreover, now that  
professional in-house  
scanning is affordable, you  
no longer have to send jobs  
out. **STAY TUNED...**

**SCITEX PRESENTS:  
AMAZING SCANNING  
PERFORMANCE BY THE**

# EVERsmart **Jazz**



For as little as  
**\$295\***  
a month

**For a demonstration  
call 1-800-685-9462  
Email: [Jazz@Scitex.com](mailto:Jazz@Scitex.com)  
or visit [www.scitex.com](http://www.scitex.com)  
Resellers invited - 781-280-7642**

Copyright 1999 Scitex Corporation Ltd. All rights reserved. Scitex, the Scitex logo, EverSmart and EverSmart Jazz are trademarks of Scitex Corporation Ltd. or its wholly owned subsidiaries and may be registered in certain jurisdictions. Specifications are subject to change without notice. \* Based on 60 Months 10% Fair Market Lease, subject to approval.

Circle 122 on card or go to [www.macworld.com/getinfo](http://www.macworld.com/getinfo)





## QuicKeys 4.0

KEYBOARD SHORTCUT TOOL

**T**HE MACINTOSH INTERFACE, although easy to use, is sometimes frustrating for control freaks—er, we mean power users. Apple provides few tools for automating repetitive tasks, giving many users wrist-lash. CE Software's QuicKeys has always been the king of Macintosh automation, and the 4.0 release secures that crown even more tightly. A slew of enhancements joins a new Setup



**Quick Help** The Setup Assistant walks you through the process of creating a QuicKeys macro, and new tool bars let you access macros without memorizing their keystrokes.

Assistant to make power users more powerful while getting novice users into the program more gently.

QuicKeys runs as a system extension, intercepting keystrokes and performing prearranged actions, such as launching an application or typing stock text. The program comes with some basic shortcuts, such as cut, copy, and paste, prewired to standard Mac keyboard function keys. Using the convenient QuicKeys editor, easily accessible from the menu bar, you can make more shortcuts, or macros. You can also assign any combination of keyboard typing, menu selections, mouse clicks, system functions, and dialog-box interactions to a single keystroke.

QuicKeys has taken some flak in the past for an unwieldy interface that new users found difficult. This release sports a Setup Assistant that walks you through the process of creating a macro, so novice users can avoid the complex QuicKeys editor. Also new is the ability to create floating tool bars that let you access macros with a single click. You can make tool bars universal—always floating above any application window—or set them to appear only in a specific program. With tool bars, you can access macros easily without assigning or remembering keystrokes.

Version 4.0 also adds a host of new plug-ins. Advanced Text Tools automates such operations as excerpting text, adding and

removing quotation marks, and changing case. New File Tools includes a batch processor for automating work on a group of files, as well as tools for changing file contents and location. The E-mail Tool lets you reply to routine e-mail with a single keystroke, adding predefined attachments and boilerplate text. The Web Tool links Web URLs to a keystroke or tool-bar icon, giving you one-click access to any Web site or online resource. Password Vault safely stores passwords in macros, and Project Saver captures your current application environment.

With cunning combinations, you can construct QuicKeys macros to do just about anything. And because macros are portable from one machine to another, users can share them to spread the time savings around.

**Macworld's Buying Advice** There's much to like in QuicKeys 4.0. Its interface improvements show that the company is responsive to usability complaints, and the new features make this a must-have tool, even if you're *not* a control freak.—MEL BECKMAN

**RATING:** ★★★★★ **PROS:** Inexpensive; Setup Assistant; tool bars; powerful plug-ins. **CONS:** None. **COMPANY:** CE Software (515/221-1801, www.cesoft.com). **COMPANY'S ESTIMATED PRICE:** \$100.

## StuffIt Deluxe 5.5

UPDATE INCLUDES FIXES, NEW OPTIONS

**A**LADDIN'S STUFFIT DELUXE, plagued by bugs and a lack of backward compatibility in version 5.0 (see *Reviews*, April 1999), is back on track with an update that offers far greater stability and a handful of helpful new options. Version 5.5 of the file-compression utility still won't let you save files in earlier StuffIt formats, but the new features make it worth considering if you have an earlier version.

Among the most-useful new features is the Archive command, which makes it easy to pull a single file out of a StuffIt archive. You simply control-click on the StuffIt archive file, select Archive from the contextual menu, and navigate through the hierarchical directory list to the exact file you wish to extract.

StuffIt Deluxe 5.5 also supports additional compression formats. You can now create Zip files with StuffIt's DropZip application or by appending the .zip suffix to any file; you can use the same suffix-renaming tactic to create UUencode files. StuffIt Deluxe 5.5 can also create self-extracting archives and Bzip files for Windows PCs.

Along with the new encoding features, Aladdin's Magic Menu now includes four additional commands—quite useful even though they have little to do with compression. Get More Info provides basic file information, Make Alias To creates an alias and places it in any designated folder, Copy/Move copies or moves files to other locations, and Gather moves selected files into a single folder. Another new component, the Secure Delete utility, trashes files so they're unrecoverable.

StuffIt Deluxe isn't quite as deluxe as it once was. Some users may be disappointed to learn that the update still can't save files in earlier StuffIt formats. Now that Apple bundles StuffIt 5.X-compatible versions of DropStuff and StuffIt Expander with the Mac OS, this isn't the big issue it once was, but some users may still need to create StuffIt 4.0 archives. Aladdin has also removed the SpaceSaver utility, which compressed and expanded files on your Mac. However, considering the capacity of today's hard drives, losing SpaceSaver is hardly devastating.

Expand	⌘U	
Stuff	⌘S	
Encode		MacBinary (.bin)
Make Self-Extracting		Stuff and MacBinary
Remove Self-Extracting		Self-Extracting and MacBinary
Verify		BinHex (.hqx)
Preferences...		Stuff and BinHex
Get More Info...		Self-Extracting and BinHex
Make Alias To...		Zip
Copy/Move...		UUEncode
Gather		Zip and UUEncode
Mail		
Stuff and Mail		
Preferences...		
Aladdin Web Technical Support		
About Magic Menu™...		

Varied Menu StuffIt Deluxe 5.5's Magic Menu sports new commands and compression options.

**Macworld's Buying Advice** With a return to stability and the addition of beneficial new features, StuffIt Deluxe is back in our good graces. If you have an older version of the software, consider upgrading (most upgrades cost \$20). If the free DropStuff and StuffIt Expander don't address all of your compression needs, buy this more capable version.—CHRISTOPHER BREEN

**RATING:** ★★★★★ **PROS:** Comprehensive compression options; useful navigation tools. **CONS:** Still not backward compatible. **COMPANY:** Aladdin Systems (831/761-6200, www.aladdinsys.com). **LIST PRICE:** \$80.





READY OVER THE CARRYING CASE.



THE LACIE POCKETDRIVE™ Measuring just 3.5" x 5.75" x 1" and weighing a mere 12.5 oz., it's the hard drive equipped with both USB and FireWire™ connections, and available in either 6 or 18 gigabytes of portable storage.

**LACIE** Made for ideas.





# Thinking Home

SOFTWARE THAT AUTOMATES YOUR HOME

**W**ITH ALL THE FUSS ABOUT smart homes and Internet-savvy refrigerators, you'd think that decades-old home-automation technology would be ready for the scrap heap. But X10, a protocol developed more than 20 years ago by X10 (www.x10.com), isn't about to run out of steam. The technology uses signals over existing electrical wiring, so it's easy to install without additional construction. When it's in place, you can control almost any electrical device without leaving your chair and repel burglars by giving your house a lived-in look when you're away.

A basic X10 setup includes three components: hardware modules to turn lamps, appliances, and other electrical equipment on and off; a computer interface to send commands to the modules; and software to program the interface hardware. While several companies sell X10-compliant hardware and software, Thinking Home 1.0.3, a \$39 program from Always Thinking, is one of only a handful of commercial X10 applications for the Mac. (See *Reviews*, February 1999, for a review of MouseHouse 2.0,

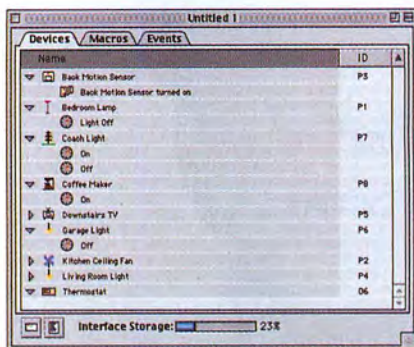

**Control List** Thinking Home's Devices list shows modules and events.

another Mac-compatible X10 program.)

Thinking Home supports most popular X10 hardware, including the defunct CP-290 interface from X10, as well as newer models such as IBM Home Director. If you don't own any X10-based hardware, Always Thinking offers a \$59 bundle that includes Thinking Home, an IBM Home Director starter kit, and a Mac adapter cable.

We had no difficulty using Thinking Home to program our CP-290 or Home Director interface, but we were disappointed by the program's lack of graphical displays and controls. For example, Thinking Home forces you to enter each module's on and off times by typing them on the keyboard or by

clicking on arrows; sliding controls would be a simpler alternative. We were also disappointed that we couldn't list the settings for all our modules at once. Additionally, Thinking Home doesn't provide a visual indication of each module's settings.

On the plus side, Thinking Home includes a remote-control function that lets you send On, Off, and Dim commands immediately to any module. There's also a handy screen that lets you monitor the status of as many as 16 modules, and this screen provides an estimate of the remaining life in the interface's backup batteries.

**Macworld's Buying Advice** At \$39, Thinking Home costs \$30 less than MouseHouse, although the latter boasts a superior event display. Unfortunately, neither application uses graphics as effectively as the Windows software that ships with X10's hardware kits. Still, Thinking Home offers a cost-effective way to program an X10-based home-automation system with your Macintosh.—FRANKLIN TESSLER

**RATING:** ★★★ **PROS:** Inexpensive; understands voice commands. **CONS:** Graphically challenged; limited display options. **COMPANY:** Always Thinking (800/556-9559, www.alwaysthinking.com). **LIST PRICE:** \$39.



## Computer-eyed?

Save Your Eyes With OTT-LITE TrueColor™ VisionSaver™ ...  
A natural light source designed for computer environments.

The culprit in "computer eyes" is usually harsh, distorted lighting. OTT-LITE VisionSaver is a breakthrough that utilizes a special blend of rare earth phosphors to create a color balanced natural-daylight environment indoors. See with startling clarity and comfort!

- VisionSaver Eliminates Eyestrain with Reduced Glare and Distortion
- See Details with Startling Clarity
- Match Colors Accurately – just like you're outdoors
- Work with Increased Precision
- Read Comfortably in a Soothing, Natural Light Environment

Call for a FREE Catalog

**1-800-842-8848** Code #MCH0003

OTT-LITE Technology, 1214 W. Cass Street, Tampa, FL 33606 www.ott-lite.com



**OTT-LITE**  
TRUECOLOR LIGHTING

Circle 42 on card or go to [www.macworld.com/getinfo](http://www.macworld.com/getinfo)



# Discover True Compatibility



## Connectix VIRTUAL PC

Connectix Virtual PC delivers true compatibility by enabling you to run multiple operating systems on your Mac. With Virtual PC, you can run Linux, Windows 2000, 98, 95, or DOS on your Mac. Now, you can be compatible with the PC world by giving your Mac the ability to run PC programs, access PC networks, and share files with your PC-based co-workers or clients.

Connectix Virtual PC is a software solution that's like having a Pentium chip in your Mac. And, it's available in 5 different versions, so you can choose which OS best suits your needs. Whether you choose to run Linux, Windows 2000, 98, 95, or DOS on your Mac, Virtual PC makes it easy to get started because each OS is pre-installed and pre-configured. Bridge the compatibility gap between Mac and PC environments by using Connectix Virtual PC!

To buy or for more information, go to [www.connectix.com](http://www.connectix.com) or call 1-800-395-1804





# Papyrus 8.0

INEXPENSIVE REFERENCE DATABASE

**F**OR A RESEARCHER WHOSE LIVELIHOOD depends on churning out academic publications, a reference manager is a godsend. By automating the most burdensome steps in research writing—tracking references, formatting citations, and compiling bibliographies—reference-management software can cut days off a large project. Papyrus 8.0.5, the latest release of Research Software Design's reference manager, handles the job competently without breaking your budget.

We were impressed by the quality and depth of the program's printed documentation, which includes an excellent introduction to bibliographic concepts. Papyrus also provides extensive context-sensitive help and summaries of shortcuts, both in HTML format. Cash-strapped researchers will appreciate Research Software Design's license agreement, which permits individual members of a research group to install Papyrus on their own computers, as long as everyone uses the same reference database. (Two users cannot make simultaneous changes to a single database file over a network, however.)

With 59 different fields, 16 predefined



**Picture Perfect** You can insert graphics into a Papyrus database by dragging or by cutting and pasting.

reference types, and a database capacity of 16 million records, Papyrus can likely handle whatever you throw at it. Papyrus even provides a field for pictures; alas, the program stores the actual images instead of just pointing to them, so databases that incorporate graphics can grow extremely large.

You can import references—saved as text files—from a variety of sources, including online and offline reference collections, as well as bibliographic database programs such as ISI ResearchSoft's EndNote and ProCite. However, unlike EndNote, Papyrus doesn't let you search for and retrieve references directly from Z39.50-compliant online databases such as the National Library of Medicine's PubMed.

Transferring citations into a word-processing document isn't as convenient as in ProCite, which lets you search for references without leaving Microsoft Word. The search dialog box, which doesn't include such text-specific operators as "begins with" or "contains," is also less straightforward than ProCite's. Once you've located the correct references, you have to copy or drag them into your manuscript. When you're ready, Papyrus formats the in-text citations and generates a bibliography. Papyrus supports documents created with Microsoft Word versions 5 through 98, WordPerfect 3.X, or Nisus Writer 5.X. Otherwise, you have to save your document as a plain text or RTF file before Papyrus can format it.

**Macworld's Buying Advice** Although it lacks some amenities, this comprehensive reference manager should satisfy most research authors' needs. At only \$99 for the CD-ROM version, Papyrus is a bargain that's hard to pass up.—FRANKLIN TESSLER

**RATING:**  **PROS:** Inexpensive; comprehensive documentation. **CONS:** Cumbersome search tools; no direct online database retrieval. **COMPANY:** Research Software Design (503/796-1368, [www.rsd.com](http://www.rsd.com)). **LIST PRICE:** Full version, \$139; CD-ROM only, \$99; online download, \$89.

## MAKE YOUR OWN MOVIES? IT'S A PIECE OF CAKE!

Connect your Digital Camcorder to your Computer and Make Movies.

With the OrangeLink® FireWire® 1394 products, you can easily connect your new DV camcorder to PCs and Macs. Load up the included video editing software (Ulead® VideoStudio™ or Adobe® Premiere LE®) and watch out George Lucas!

You're now the director, and making movies is a snap. Cut and paste video clips, add titles and credits, music or voice overs, and a host of scene transitions to give your movie a professional touch.

Lights! Camera! Action! It's a piece of cake with OrangeLink and Desktop Video.



OrangeLink FireWire 1394 PCI Boards for Desktops: \$129-\$159



OrangeLink FireWire 1394 CardBus PC Card for Portables: \$149

**Orange Micro inc.**  
[www.orangemicro.com](http://www.orangemicro.com)



# Think Better!

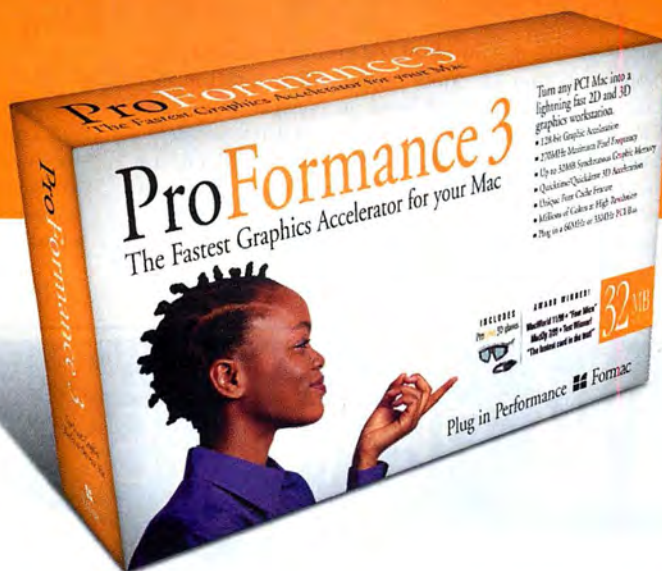

Award  
Winning  
Performance

## NEW!!!

Enjoy true 3D with  
our new wireless  
and super light  
ProCyber 3D  
glasses.



## The fastest graphics accelerator for your Mac just got better.

ProFormance 3 performed nearly twice as fast as its nearest competitor in tests run by major magazines worldwide. But that's only one of the many reasons why it has become the first choice for Web, graphics, and multimedia professionals. The long list includes: OpenGL compatibility; true 3D with the

ProCyber 3D virtual reality glasses; better digital output connectivity - with your choice of VESA or SGI Flat Panel Display standards, or SVideo Out. And much more! So why wait? Find out how to get your Mac to think better, just visit [www.formac.com](http://www.formac.com) and learn how easy it can be.

IT'S A WINNER!  
"Photoshop  
acceleration  
was especially  
impressive."  
*Macworld 11/99*



AMAZING!  
"Delivers Killer  
Performance!"  
*MacAddict 11/99*

BEST VALUE!  
"Best Value Graphics  
Card on the Market."  
*MacUser 8/99*

IT'S THE FASTEST!  
"Fastest Photoshop  
Performance!"  
*XLR8YOURMAC 10/99*

OpenGL  
Shipping Now!

 Formac

Formac Electronic Inc. 5673 West Las Positas Blvd., Suite 213 Pleasanton, CA 94588 Tel. 925 251 0100



# MacWasher

UTILITY COVERS TRACKS OF WEB WARY

**M**OST OF US THINK TWICE before giving out a credit card number. But have you ever stopped to think how much personal information is readily available to anyone who sits down at your Mac? For instance, the Recent Documents folder in the Apple menu lets anyone see which documents you've recently opened. And your Web browser is an open book on your Web habits: it stores a history of the sites you've visited; temporary items (such as graphics) that make up Web pages; and *cookies* that tell Web sites who you are, where you've been, and so on. If you want to avoid leaving such telltale tracks, MacWasher 1.0.2, an inexpensive utility from Webroot Software, may be the solution.

From MacWasher's main screen (see "Wash This"), you can configure the application to delete any of the following items: the Apple menu's Recent Documents and Recent Applications lists; log files from MacsBug (Apple's debugging tool); and the contents of the Temporary Files folder, the Trash, and folders you've specified. America Online users can tell MacWasher to delete the cache as well

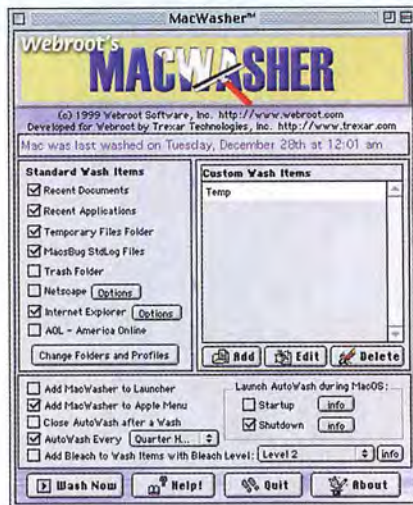

**Wash This** You can set all of MacWasher 1.0.2's options in this window. Click on the Wash Now button to give your system an immediate cleaning.

as the download and history folders. In addition to those items, Microsoft Internet Explorer and Netscape Navigator users can also instruct MacWasher to delete cookies.

Deleting files makes it difficult for casual users to discover what you've been up to, but MacWasher can also "bleach" files—overwriting them from one to ten times. Three and seven overwrites meet Depart-

ment of Defense (DOD) and National Security Administration standards, respectively. Bleaching can be extremely time-consuming: to bleach a single 350K file one, three, and seven times took 2.5, 7.4, and 17.0 minutes, respectively.

Bleaching prevents data-recovery tools from resurrecting the deleted data; however, it does not prevent them from displaying the *names* of the bleached files. By comparison, Norton Utilities' Wipe Info can overwrite selected files and folders in a few seconds, not only meeting DOD security requirements but also deleting the file names.

**Macworld's Buying Advice** While MacWasher will find a welcome home with computer novices, more-experienced users will quickly find other ways to meet MacWasher's security objectives. For example, you can turn off your Web browser's history, disable cookies, and create simple AppleScripts to delete the contents of selected folders.—STEVE SCHWARTZ

**RATING:** \$\$\$½ **PROS:** Easy to configure; flexible. **CONS:** Technical support via e-mail only; bleaching is time-consuming and doesn't hide names of deleted files. **COMPANY:** Webroot Software (800/772-9383, [www.macwasher.com](http://www.macwasher.com)). **COMPANY'S ESTIMATED PRICE:** \$30.

# Macworld REPRINTS

Leverage the positive impact of your editorial coverage by using Macworld reprints for direct mail campaigns, seminar promotions, media kits, employee communications, recruiting and marketing programs.

**Call Reprint Management Services today for more information on Customized Editorial Reprints.**



**RMS**  
REPRINT  
MANAGEMENT  
SERVICES

**Brian Shipe**  
717.399.1900  
[bshipe@rmsreprints.com](mailto:bshipe@rmsreprints.com)  
[www.rmsreprints.com](http://www.rmsreprints.com)



ESCIENT

Digital Storage Group



Introductory Price

**\$1,499**

through March 31st, 2000

INTRODUCING THE

## **PowerFile C200**

DVD CHANGER

Complete DVD/CD Asset Management Solution



this changes  
EVERYTHING

200 DISC CAPACITY DVD/CD CHANGER | DUAL DVD/CD-ROM DRIVES

HIGH-SPEED FIREWIRE (IEEE-1394) CONNECTIVITY | MAC OR WINDOWS COMPATIBILITY

1 TERABYTE OF STORAGE | CLIENT/SERVER LIBRARY MANAGEMENT SOFTWARE INCLUDED

— \$1,799 —

[WWW.DVDCHANGER.COM](http://WWW.DVDCHANGER.COM)

1-877-219-4888 (TOLL-FREE)

Escient is a registered trademark of Escient, Inc. Macintosh and FireWire are registered trademarks of Apple Computer, Inc. Windows is a trademark of Microsoft, Inc.



## Descent 3

3-D SHOOTER RETURNS, BUT BUGGY

**T**HOSE WHO'VE NEVER HAD THE opportunity to float about in weightless conditions—pinging around the interior of an orbiting space shuttle, for example—may find Graphic Simulations' Descent 3 a bit disorienting. After all, like other gravity-free environments, Descent 3 lets you maneuver on all axes, and it's often difficult to determine where "down" stops and "up" begins.

Descent is a name familiar to longtime Mac gamers. Descent I and II—3-D shooters that placed you behind the controls of a laser- and missile-equipped spacecraft sent to battle nefarious robots—were very popular titles on the Mac. At first blush, Descent 3 looks like more of the same. As in the earlier games, you buzz through robot-infested environments, blasting anything that moves and most likely succumbing to the vertigo induced by jinking your craft around in spaces where you have no real sense of direction.

Once that first blush wears off, however, you'll realize that Descent 3 has more in common with modern shooters such as Quake than with earlier iterations



**The Great Outdoors** Descent 3 breaks from past versions of the action game by allowing you to take your troubles outside.

of Descent. In the original Descent, your object was to locate a reactor, blow it to pieces, and then quickly find your way out of a labyrinthine mine before the whole works exploded in your face. Descent 3 is more Quake-like: it asks you to carry out a series of tasks—locate a security key, for example—in order to progress through a mission. Descent 3 also differs from the original in offering outdoor environments.

Descent 3's modern system requirements include 3-D-acceleration hardware—via either some kind of 3dfx Voodoo card or an ATI Rage Pro or Rage 128—and a 233MHz or faster G3 Mac.

If your Mac meets or—even better—

exceeds these requirements, the look of the game won't disappoint you. Descent has never been more attractive. And the benefits of this lush look are more than skin deep: thanks to Descent 3's enhanced graphics, you can actually make out enemy robots hovering at a distance.

Regrettably, the OpenGL version of Descent is far from stable. Even after we upgraded the original and *very* buggy version with the 1.3.1 updater, we had problems in OpenGL mode—blocks of graphics disappeared and the game occasionally locked up. We hope Graphic Simulations will address these problems in another update. In the meantime, if you have a Voodoo card, play the game in the more stable Glide mode.

**Macworld's Buying Advice** Descent 3 is a great game marred by bugs. Those with Voodoo cards, fast Macs, and a love of frenetic action will have a blast. If your ATI-equipped Macintosh lacks a Voodoo card, either add one or wait for the next game update.—CHRISTOPHER BREEN

**RATING:** ★★★ **PROS:** Furious action; beautiful graphics. **CONS:** OpenGL version is buggy. **COMPANY:** Graphic Simulations (972/386-7575, www.graphsim.com). **LIST PRICE:** \$45.

# THE #1 MACINTOSH RESOURCE

Get super savings on a subscription, plus a FREE CD-ROM.



Incisive Product Reviews  
Lab-based Performance Tests  
Tips, Tricks & Tutorials  
Technical Solutions  
Coverage of Emerging Technology  
And much more!

Macworld is the best way to stay on top of today's fast-changing Macintosh technology. And here's your chance to save big on a subscription, plus get the exclusive Macworld Clip Art CD-ROM containing an extensive collection of images, digital stock photos, and more — FREE with your paid order.

To get it all, go to  
<http://subscribe.macworld.com>



# The Internet-Savvy Contact Manager & Calendar



**POWER ON  
SOFTWARE**  
The *POWER* of Productivity.

**W**hether you drive a desktop Mac (even a trusty old 68K machine running System 7), pound a PowerBook, or pack a Palm®, you need Now Up-to-Date & Contact, the best choice in contact management and calendaring. No other product allows you to keep track of your contacts and schedule so easily. With its ability to recognize common phrases and automatically enter items on your calendar, you will spend less time on data entry. Built-in email tracking; word processing with mail merge; label and envelope generators with postal bar codes; and alarms to remind you of key events make this an essential product for anyone who needs to save time and stay organized. A built-in TCP/IP server allows you to add users and share group data, while keeping personal information private. Designed for the Internet, Now Up-to-Date & Contact offers a unique web plug-in architecture that will have you soaring through cyberspace. Need a map or an e-mail address for someone? Click the blazingly fast search engine to find the contact and let the software do the rest! It is no wonder that Now Up-to-Date & Contact is the #1 best-selling Macintosh PIM on the planet.

Phone: 800-344-9160 ■ 612-317-0344 ■ Fax - 612-317-0345 ■ <http://www.poweronsoftware.com>

Copyright ©1999 by Power On Software, Inc. All rights reserved. Now Up-to-Date and Now Contact are registered trademarks of Power On Software, Inc. Macintosh is a registered trademark and Finder is a trademark of Apple Computer, Inc. Palm Computing is a registered trademark and Palm V is a trademark of Palm Computing, Inc., 3Com Corporation, or its subsidiaries. All other trademarks acknowledged.



# DRIVER™

YOU ARE THE WHEELMAN™

YOU ARE THE DIFFERENCE BETWEEN THE  
BIG HOUSE AND A BIG HOUSE IN MALIBU.

YOU ARE THE DIFFERENCE BETWEEN 500 G'S AND  
10-15 IN MAXIMUM SECURITY.

YOU ARE THE FASTEST DRIVER IN THE ENTIRE  
CRIMINAL COMMUNITY.

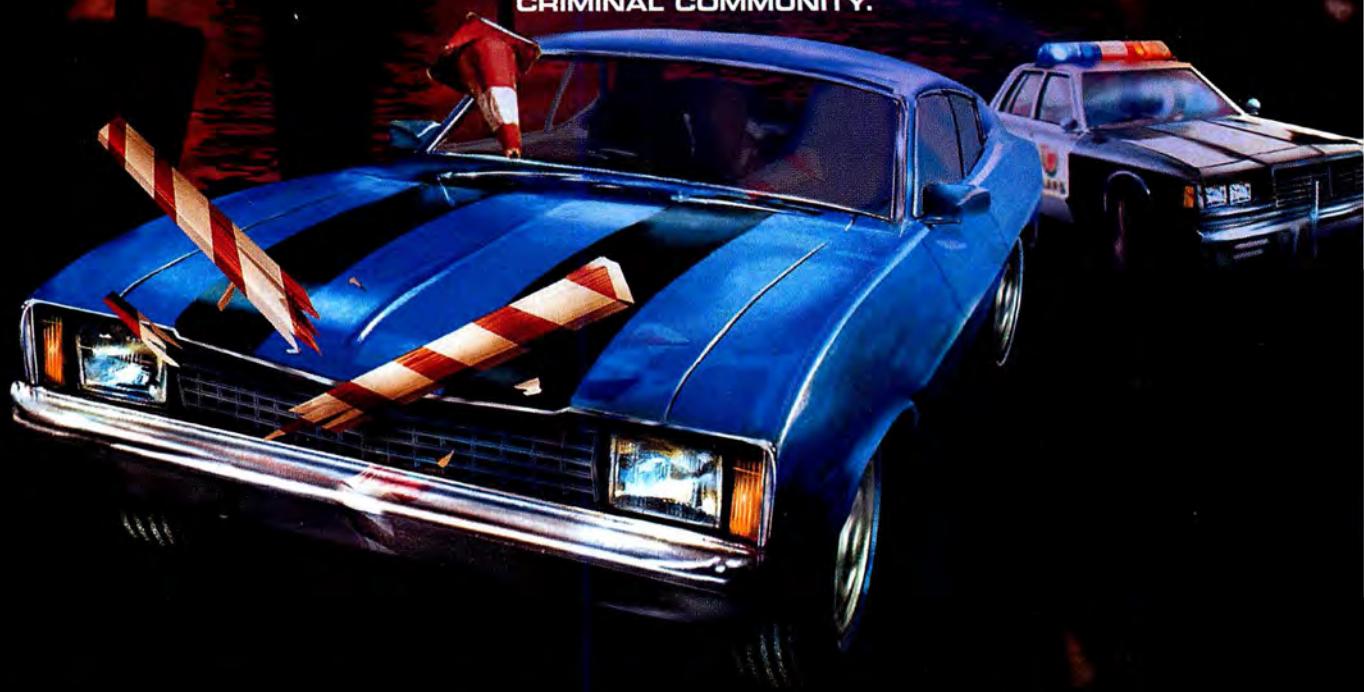

**SAN FRANCISCO**

Film your own classic 70's car chase  
using incredible Director-Mode.



**LOS ANGELES**

Surveillance. Tailing. Deliveries.  
Heists. And serious 70's muscle cars.



**MIAMI**

Getaway through real pedestrians,  
traffic signals, traffic...and cops!



**NEW YORK**

No tracks. Just 4 sprawling urban  
downtowns from NY to San Fran.



THE BEST-SELLING GAME FOR THE PC & PLAYSTATION®

**COMING SOON FOR THE MAC!**

Driver™ © 1999 GT Interactive Software Corp. All Rights Reserved. Created by Reflections Interactive Limited, a GT Interactive Software Corp. studio. Published and distributed by MacSoft, a GT Interactive Software Company. Reflections and the Reflections logo are trademarks of Reflections Interactive Limited. All other trademarks are the property of their respective companies.

Circle 29 on card or go to [www.macworld.com/getinfo](http://www.macworld.com/getinfo)

**MacSoft®**

A GT Interactive Software Company  
[www.wizardworks.com/macsoft/](http://www.wizardworks.com/macsoft/)



# The Game Room

## Hot-Rod Your Mac

TURN YOUR OLD MAC INTO A KILLER CUSTOM GAMING RIG

by Christopher Breen

Like any columnist who proffers opinions only slightly more controversial than the telephone directory's white pages, I get my share of unanswerable mail from the tragically "het up." Such missives generally run along these lines: "I herd from my secund cusin Bubba that someone on som news groop said that you were a magazin riter that said that Gallactic Space Wars was a stupid game. Well I think that your stupider! Gallactix Space Wars is really grate and if you dont know that your really really stupid!! If I had a subscripshun to your stupid magazine Id cancel it cuz you so stupid!"

Now, don't get me wrong: I love getting mail—regardless of how often people question my intelligence and morality. But other than suggesting that spelling checkers have come a long way in the past few years, how do you respond to something like the preceding? However, every so often I get a letter from a correspondent who's actually read my column, and—though its tone may be slightly confrontational—within the message lies a cogent concern. Specifically: "I herd from my secund cusin Billy-Bob that someone on som news groop said that you were a magazin riter that said you could put a voodoo card in your Mac. I looked at my latest ishoo of MacWorld and saw that you said that to. If your so smart why dont you tell us how to do it instead of just saying it stupid!"

This reader has a point. It's easy enough for me to cavalierly mention that I've upgraded my Macs in one way or another, but unless I relate the ins and outs of doing so, you possess only a small piece of the puzzle. Allow me now to make amends by describing how I trans-

formed my 266MHz Power Mac G3 (beige) from a hefty hunk of steaming junk into a game machine that holds its own against the latest G4s.

### Room to Move

If you're a Mac gamer, you understand that computer-game publishers have the kind of gung-ho, Manifest Destiny spirit found in this nation's early settlers. "Move aside, lowly word processor!" modern Mac games cry. "We've got

if, like me, you have a beige G3 without a Rage Pro graphics chip, you can't add a second IDE drive at all unless you sacrifice your CD-ROM drive (the CD-ROM drive is the other IDE device on the chain) or purchase a PCI IDE card such as ProMax Technology's ([www.promax.com](http://www.promax.com)) \$200 TurboMax. I had plans for my three PCI slots, and I wasn't about to give one up simply to add another hard drive.

I wanted something fast, expansive, and inexpensive, and I found it in Maxtor's ([www.maxtor.com](http://www.maxtor.com)) 27.2GB DiamondMax Plus EIDE drive. Because this 7200-rpm drive—with an average access time of less than 9 seconds and a 2MB buffer—cost all of \$250, I discarded any thoughts of saving my old drive.

Moving data from my old drive to the new Maxtor drive was a cinch. I simply pulled the IDE and power cables from the CD-ROM drive and attached them to the new Maxtor drive (I placed the drive, circuit board facing up, atop the power supply inside the opened case), and then I ran Apple's Drive Setup to initialize the new drive. Once initialized, the drive appeared on the Mac's desktop, and from there I copied all the data from my old drive to the new one. With that done, I removed the old drive, installed the Maxtor in the old drive's place, and reattached the CD-ROM drive's cables.

### 3-D Times Two

The 266MHz G3 processor inside my Macintosh is robust enough to play some



500MB of data to plant on this here hard drive, and by gum, we mean to plant it!"

As you might suspect, I play a *lot* of games, and in short order, half a dozen of these massive game installations filled my Mac's 4GB hard drive to the tippy-top. I needed something roomier.

These early-model beige G3 shipped with internal IDE drives (rather than SCSI drives), which can make adding a second internal drive tricky because you can chain only two IDE drives together. Worse yet:



# The Voodoo You Do So Well

UNLIKE VOODOO3 CARDS, VOODOO2 CARDS PROVIDE A PASS-THROUGH CABLING scheme—you connect your monitor to the output port on the Voodoo2 card, and attach the included pass-through cable to the Voodoo2's video-input port and your Mac's (or video card's) video-output port. When a game requires 3-D hardware acceleration from the Voodoo2, the Voodoo card takes over the graphics chores.

Although the Voodoo2 chip set can crank out frame rates nearly comparable to those of ATI's Rage 128 chip set, it has limitations: it doesn't support resolutions higher than 800 by 600 pixels, and it renders only 3-D graphics—you still need some kind of 2-D output, either from your Mac's on-board video or from an installed video card such as ATI's Rage Orion.

3dfx's Voodoo2 1000 PCI card costs less than \$70, and you can find Mac drivers for it on 3dfx's Web site ([www.3dfx.com](http://www.3dfx.com)).

fairly demanding games, but the wimpy on-board 3-D—graphics chip is incapable of anything but the most basic hardware acceleration. Some of the games I cherish—Pangea's Bugdom, for example—require the RAVE hardware-acceleration API, while others prefer the Glide or OpenGL standards. I need hardware acceleration that will work with all three of these standards, and no one board currently handles them all adequately. To cover my bases, I filled one PCI slot with a Rage 128-based ATI Rage Orion card (\$149; [www.atitech.com](http://www.atitech.com)) that supports RAVE and OpenGL, and I filled my second PCI slot with a 3dfx Voodoo3 2000 card (\$90; [www.3dfx.com](http://www.3dfx.com)) that supports OpenGL and Glide games.

Now, hang on a second there, Jimmy-Joe—before you send off that acrimonious letter, allow me to explain: I know full well that installing these two cards requires that I either have a monitor for each card or plan to swap the monitor cable from one card to the other on a regular basis. I'm fortunate in that I do have a couple of spare monitors, so adding a second monitor is no big deal for me—but you might not be as monitor-rich as I am. If you have a single monitor, you can play the cable-switching game or you can add a Voodoo2 card (see the sidebar, "The Voodoo You Do So Well").

For those with dual monitors—and I should mention that you'll need two multisync-resolution (not fixed-resolution) monitors—this two-card monte isn't a bad way to go. However, there's a trick to using the Voodoo3 card. It's intended for PCs, and to use it with a Macintosh, you must update the card's ROM and install Mac-compatible drivers. Fortunately, you can find the Macintosh drivers and the FlashROM utility on 3dfx's Web site. To update the ROM



**Before-and-After Science** The clear differences between Unreal Tournament rendered under software (above) and with a Rage 128 chip (below) should be compelling enough reason to upgrade to hardware acceleration.



you need to connect your monitor to a video source other than the Voodoo3 card, install the card in a free PCI slot, and run the FlashROMVoodoo3 utility. Instructions for doing this are in the Mac Voodoo3Drivers folder.

Most games that offer both Glide and OpenGL or RAVE acceleration will automatically choose the appropriate card and monitor—the Voodoo3 card for Glide games and, by default, the ATI card for OpenGL and RAVE games. If you want to use your Voodoo3 card for OpenGL acceleration—not a bad idea considering that at higher resolutions a Voodoo3 card seriously spansks anything ATI has on the market—you may have to muck about with drivers to get this to work.

For example, while testing the Quake III: Arena demo, I had to turn off the OpenGLRendererATI extension for the game to work with the Voodoo3 card. Quake II requires that you play the game on the monitor that bears the menu bar. If you want to play the game with the Voodoo3 card, open the Monitors & Sound control panel (or Monitors if you're using OS 9), click on Arrange, and move the menu bar to the monitor attached to the Voodoo3 card. Wacky.

## Fire It Up

Although a 3-D card offers the most bang for your gaming buck, you can boost frame rates even more with a CPU upgrade. I did just that with Newer Technology's 400MHz Maxpower G3 upgrade (\$460; [www.newertech.com](http://www.newertech.com)). On average, this upgrade bought me an extra 12 frames per second in Quake II at a resolution of 640 by 480 pixels on both the ATI and Voodoo3 cards.

## Lock It Down

Not all of you have beige Power Mac G3s, so these exact upgrades may not apply to you. But they certainly indicate the steps you can take to make your Mac a finer and faster gaming machine. If you have other suggestions to offer, feel free to drop me a line. I just love reading the mail. **m**

Contributing Editor CHRISTOPHER BREEN is happy to do the numbers for those readers who are math- as well as spelling-challenged. The total upgrade cost for his beige Power Mac G3 was \$949, without tax.



FROM THE CREATORS OF DOOM

FASTER, SMARTER  
AND MORE INTENSE  
BATTLES THAN  
ANY GAME EVER.  
PERIOD.

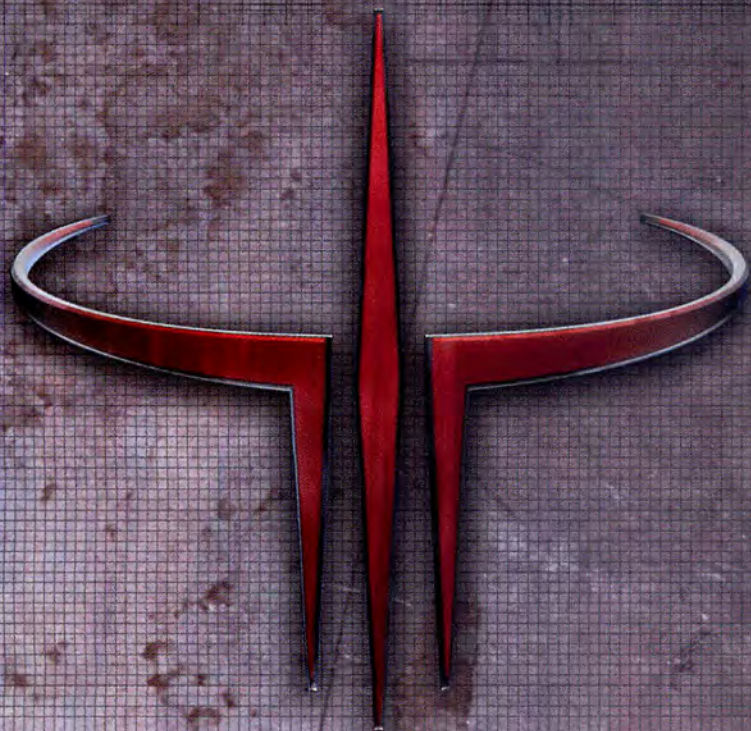

# QUAKE III ARENA

"GAME OF THE YEAR" - PC ACCELERATOR

QUAKE III ARENA COMBINES ALL THE EXCITEMENT AND CARPAGE YOU EXPECT FROM ID SOFTWARE WITH GROUND BREAKING ARTIFICIAL INTELLIGENCE AND THE MOST POWERFUL 3D ENGINE EVER CONCEIVED FOR A GAME. WHETHER YOU WANT TO PLAY A CLASSIC FRAGMATCH IN THE SINGLE PLAYER MODE OR TRY YOUR LUCK AGAINST THE ONLINE PROS, QUAKE III ARENA DELIVERS THE BEST GAME PLAY YET BACKED UP WITH STUNNING GRAPHICS AND 30 CHALLENGING MAPS. IT'S GOT SOME AMAZING NEW TRICKS TO SHOW OFF. THE ONLY QUESTION IS: DO YOU?

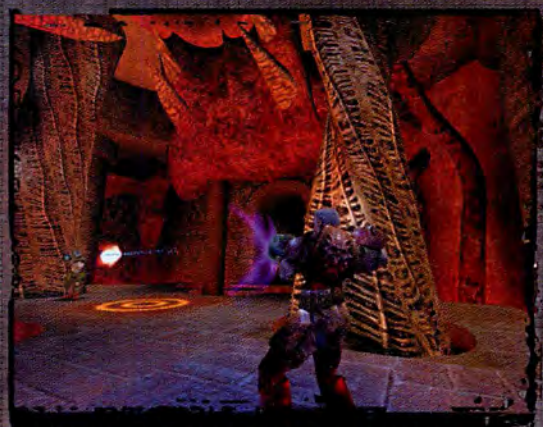

"ALL HAIL THE KING OF MULTIPLAYER 3D ACTION"  
- COMPUTER GAMES



"...QUAKE III WILL REVOLUTIONIZE THE  
INDUSTRY" - PC MAGAZINE

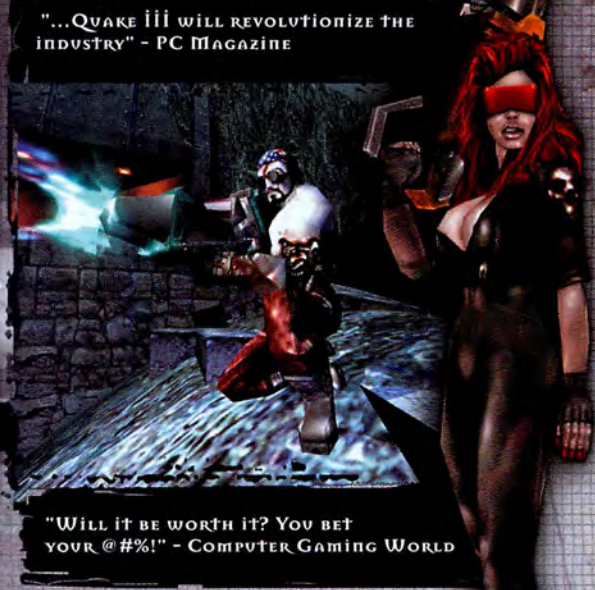

"Will it be worth it? YOU BET  
YOUR @#%!" - COMPUTER GAMING WORLD

Quake III Arena™ © 1999 Id Software, Inc. All Rights Reserved. Quake III Arena™, QIII™, and the Id Software™ name are trademarks of Id Software, Inc. in all countries in which this game is distributed. The Id logo, Q, QII, and Quake are registered trademarks of Id Software, Inc. in the United States. Macintosh is a registered trademark of Apple Computer, Inc. All other trademarks and trade names are properties of their respective owners.

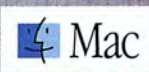

NOW AVAILABLE  
FOR MACINTOSH!

Circle 24 on card or go to [www.macworld.com/getinfo](http://www.macworld.com/getinfo)



# Who Needs HOLLYWOOD?

**F**lashback: Focus on a time when making movies on your Mac could be a real chore.

First you had to figure out how to get video into the computer. Then you had to buy and learn the software that let you rearrange scenes and add effects and titles. Aspiring Spielbergs with a bankroll and some time to kill could do it. But what if you simply wanted a nice home movie?

Cut to the present: The latest crop of digital video camcorders and Apple's new video-editing program put moviemaking on your Mac for a song. To help put you in the director's chair, we've assembled helpful iMovie tips and found the best digital video camcorders. Action! Roll tape!

*Illustrations by JOHN CRAIG*







# HOME-MOVIE

## Magic

*iMovie Tips and Tricks*  
*Put You in*  
*the Director's Chair*

**N**ext to yelling “fire!” in a crowded theater, there’s no better way to clear a room than to get out the home movies. It isn’t that friends and family aren’t interested in seeing little Mary battle gravity on her first bicycle—it’s that the presentation often leaves something to be desired. Most home videos are seemingly endless series of unrelated scenes, their length made all the more painful by jerky camera movement and unintelligible sound. They’re moving pictures, but they aren’t *movies*. A movie tells a story, and any form of storytelling can benefit from planning and editing. Fortunately for home-movie audiences everywhere, today’s desktop moviemaking tools can help. Apple’s \$1,299 iMac DV (the *DV* stands for “digital video”) or \$1,499 iMac DV Special Edition (800/795-1000, [www.apple.com](http://www.apple.com)), combined with the iMovie software that comes with them, can make a terrific home-movie studio. You can bring video into the iMac DV; then you can use iMovie to remove the boring parts and add sound and special effects. When you’re finished, you can export the final product to videotape, publish it on the Web, or e-mail it to others.

iMovie makes moviemaking easy, but it still has complexities and limitations that may frustrate even seasoned Spielbergs. Here’s a look at the production process, along with some tips for working faster and getting around the application’s limitations. For tips on planning your movie, see the sidebar “Planning Makes Perfect.”

### **Reel It In: Capturing Video**

The first step in creating your home-movie blockbuster is getting that footage of Mary’s first bike ride off your camcorder and into your iMac DV.

**Use a Compatible DV Camcorder** Unlike other home-movie tools, iMovie is designed exclusively for use with camcorders that use MiniDV tapes and have a fast, FireWire interface. If you don’t have a DV camcorder with FireWire, see the

sidebar “Moviemaking for All USB Macs.” For a comparative review of digital camcorders, see the accompanying feature, “Camcorder Casting Call.”

Connect your iMac DV and your DV camcorder with a FireWire cable, and you can bring video into your Mac (and send it back to tape) with remarkable ease. The iMovie software controls your camcorder—rewinding, pausing, playing, and recording—in much the same way that professional video-editing software controls high-end video decks. This kind of device control eliminates groping for your camcorder’s play, rewind, and other tape-control buttons as you work, and it enables you to record your completed efforts to tape with the click of a mouse.

Note that iMovie’s device-control delights work only if you have one of the DV camcorders that iMovie supports (see a current list at [www.apple.com/imovie/gear/](http://www.apple.com/imovie/gear/)). If your DV camera isn’t on Apple’s list, you may have problems capturing or exporting video—for example, when you try to export video, your camcorder may not actually go into record mode. Camcorders from JVC are especially prone to problems, due to JVC’s implementation of the FireWire interface. The aforementioned Web page contains tips on dealing with problematic camcorders, but the bottom line is that you’ll save yourself some aggravation by beginning with a compatible camcorder.

**Start Your Epic** Once the camcorder is connected, starting a new project in iMovie couldn’t be easier. Just choose New Project from the File menu, give your movie a name, and click on Create. Behind the scenes, iMovie creates a folder with the name of your movie. Once you’ve made edits and added ele-





ments, this folder will contain a document icon that represents your project's edits and a Media folder that holds your project's video clips, sounds, titles, and other elements.

**Separate Scenes** When you import—or capture—video, iMovie places a representative icon on a “shelf.” From there you can add the clip to your project. You could capture an entire 60-minute DV cassette as a single clip (if you had enough free disk space—more about this in a moment), or you could import only specific scenes. But locating such scenes would be tedious. You’d wear out your tendons hunting through an hour of birthday-party footage for the magic moment when your dog discovered the birthday cake.

A better technique is to use iMovie’s scene-detection feature, which causes iMovie to begin a new clip each time it detects a scene break. (Your camcorder generates a scene break automatically each time you press its record button.) To turn on scene detection, choose Preferences from the Edit menu, click on the Import tab, and then check the box labeled Automatically Start New Clip At Scene Break.

**Belly Up to the Spacebar** You can also start and stop clip capture by pressing the spacebar as a videotape plays back. This is a handy way to grab portions of scenes: click on iMovie’s Play button to play the tape, and when you see something you want to capture, hit the spacebar to grab it.

**Build a Bigger Shelf** Despite its name, the iMovie shelf is not one long area, but a grid of thumbnail images. It holds a finite number of clips; the specific number depends on, of all things, the iMac DV’s screen resolution. The shelf can hold

only 9 clips at the iMac DV’s default 800-by-600-pixel resolution. To expand its capacity to 12 clips, use the Control Strip or the Monitors control panel to boost the screen resolution to 1,024 by 726. Whatever you do, don’t change the resolution to 640 by 480—doing so causes iMovie to quit. Regardless of the screen resolution, the movie’s final dimensions remain the standard 720 by 480 pixels.

**Disk Space—the Diminishing Frontier** Beware: Each minute of digital video inhales about 210MB of disk space, so unless you really have hard-disk space to spare, don’t capture anything that you *know* won’t make it into your final project.

by Jim Heid



### Sounds, Stills, Movies: Acquiring Other Content

A real movie uses more than just moving pictures to tell its story—music, sound effects, and still images help to set a mood and enhance the presentation. And hey, some spice can be fun. Why not have “Born to Be Wild” playing as Mary wobbles successfully down the sidewalk on her two-wheeler?

iMovie can also import other types of content: audio files saved in the standard AIFF format, music tracks from audio CDs, and still images saved in any of several popular formats. You can even coerce iMovie into importing existing QuickTime movies that you’ve created in other programs or downloaded from the Internet. Read on to learn how.

**Use CDs for Soundtracks—Legally** iMovie’s ability to record music tracks from audio CDs makes it easy to add music soundtracks to your production. But remember that you can’t sell or commercially release movies containing copyrighted tunes. For commercial projects, invest in a *buyout* music library. Akin to royalty-free stock photography, buyout libraries are offered by companies such as Award Winning Music ([www.royaltyfreemusic.com](http://www.royaltyfreemusic.com)) and many others. (Do a Web search on *buyout music* to see what’s available.)

**Import Photos and Make Slide Shows** You can import still images into a project and combine them into a video slide show, or you can sprinkle them throughout your movie. Still images are often a big part of documentary filmmaking—think of Ken Burns’s epics on the Civil War and on baseball, and then consider how you might apply stills to your efforts. Making a video of your grandmother’s 90th birthday party? Scan some vintage photos of her and start your movie with them. Have a bunch of great digital images of your vacation? Assemble them and end your vacation movie with a montage.

iMovie lacks image-tweaking features, so if you want to crop, rotate, or otherwise tweak images, do so using an image-

editing program, such as Adobe Photoshop or PhotoDeluxe (800/833-6687, [www.adobe.com](http://www.adobe.com)), and then import the edited images. iMovie can import all common image formats.

iMovie displays still images for a default time of 10 seconds. To make your slide show or montage’s pacing more interesting, vary the duration of still images. To change the amount of time an image appears on the screen, select the image and then type a duration value in the time area of the Clip Viewer. After you’ve imported images, add transitions between them (cross-dissolves work well).

**Import QuickTime Movies** Your kid dressed up as Darth Vader for Halloween—so why not include a snippet of the *Star Wars* trailer in your Halloween video? (Just don’t try to sell the resulting movie.) Alas, iMovie can’t import QuickTime movies that you’ve captured using analog gear, downloaded from the Web, or copied from a CD-ROM. But if you have Apple’s \$29 QuickTime Pro ([www.apple.com/quicktime/upgrade/](http://www.apple.com/quicktime/upgrade/)), there is a workaround. Open the movie with QuickTime Player, select the Export command, and choose the Movie To DV Stream option from the Export pop-up menu. Next, locate your project’s Media folder and save the file there. Now start iMovie and open your project. iMovie will report that your project contains one or more “stray files” and will put them on the shelf; now they’re ready to be added to your movie.

Note that each minute of an exported DV stream will gobble the same 210MB of disk space as freshly captured digital video. Compressed QuickTime movies balloon to gargantuan sizes when saved as DV streams.

**Import Analog Video** iMovie is great for all the footage you shoot with your new DV camcorder, but what about the years of memories you’ve collected with your trusty VHS camcorder? iMovie’s DV-centric nature works against you if you’d like to capture or edit analog footage.

## PLANNING MAKES PERFECT

**M**AKING GREAT MOVIES TAKES MORE than great software, of course. First you need the right raw material. Some advance planning will help ensure that you have the money shots. And following some basic videography techniques will make for more-professional results.

*Planning* means “developing an out-

line”—in Hollywood parlance, a *storyboard*—that lists the shots you’ll need in order to tell your tale. Professional moviemakers storyboard every scene and camera angle. You don’t have to go that far, but you will tell a better story if you plan some shots.

Consider starting with an *establishing shot* that clues viewers in on where your story

takes place: for example, a shot of the swimming pool. To show the big picture, zoom out to your camcorder’s wide-angle setting.

From there, you might cut to a *medium shot* that introduces your movie’s subject: little Bobby preparing to belly flop off the diving board. Next, you might *cut away* to Mary tossing the ball. Cut back to Bobby, and then

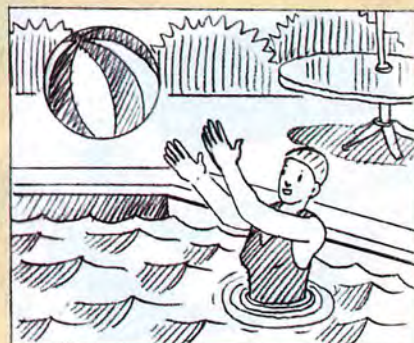
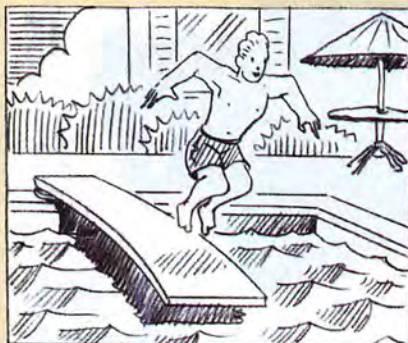
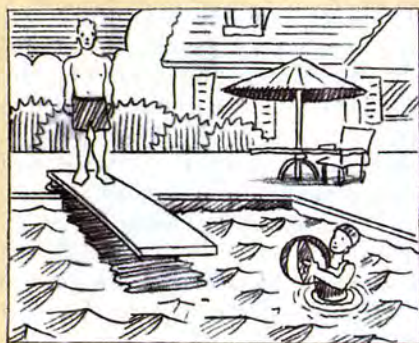



Apple suggests buying an analog-to-DV converter—specifically, Sony's \$499 DVMC-DA1 (800/222-7669, [www.sony.com](http://www.sony.com)). This converter transfers analog footage directly to your iMac. But why spend a third of what the iMac DV costs? Simply dub your analog cassettes to your DV camcorder by connecting the analog VCR's outputs to the DV camcorder's inputs with standard video patch cords. (You can get a dubbing kit, catalog number 15-1103, from Radio Shack for \$6.99.) Once you've made the connections, press your DV camcorder's record button and your VCR's play button. When you've finished, use iMovie to capture the DV dub.



### The Cutting-Room Floor: Making Edits

Once you've brought the raw material into iMovie, you're ready to assemble your masterpiece. How? Simply drag clips from the shelf into the Clip Viewer, whose timeline-like display enables you to sequence clips, add transitions, and more.

**Name Your Clips** iMovie automatically names captured clips, but names like *Clip 01* and *Clip 02* aren't exactly descriptive. You can rename clips simply by clicking on their names. Give them descriptive titles, such as *Bird Close-up* or *Forestwide Shot*, to help you identify them.

**Trim the Fat** Chances are, each of the clips you capture

has extraneous junk at its beginning and ending—some jerk momentarily blocking your view of the recital stage—or maybe just a few seconds of uninteresting footage. By removing—or cropping, in iMovie terms—this excess, you'll make a better movie (and reclaim gobs of disk space as a bonus). To crop a clip in iMovie, you position crop markers to indicate the material you want to keep.

**Empty the Trash** When you crop a clip, iMovie puts its discarded portion in the Trash—not the same Trash the Finder provides for discarding unwanted icons, but a separate, iMovie-specific Trash. You can reclaim disk space by emptying iMovie's Trash as you work (choose Empty Trash from the File menu). But if you've done a lot of cropping, emptying the Trash can take a few minutes, so wait until you're ready to take a break.

**Play Only One Thing** Remember that you can choose to play just one item—a clip, a title, a transition, or a music soundtrack—by selecting that item in the Clip Viewer and then clicking on the Play button or hitting the spacebar. This can be a handy way to check out a title or transition you've just added. To play an entire project, deselect everything (press  $\text{⌘-D}$  or click in a blank area of the Clip Viewer) and then click on Play.

**Move Clips Faster** If you need to move a clip a significant distance—say, from the end of a project to the beginning—you can drag it and let the clip window scroll automatically. But there's a faster way. Drag the clip from the Clip Viewer into any empty box on the shelf. Scroll through the Clip Viewer to the new destination, and then drag the clip from the shelf back into the viewer.

finish with a *long shot* of the entire scene.

And remember, you don't have to shoot every scene in chronological order—sequencing your shots is what iMovie is for. For example, shoot Mary's throw any time you like and edit it into the proper sequence using iMovie.

It's worth mentioning, by the way, that Avid Technology's (800/949-2843, [www.avidcinema.com](http://www.avidcinema.com)) Avid Cinema program provides a superb built-in storyboarding feature that helps you plan your scenes. The Avid Cinema manual also contains terrific tutorials on moviemaking. Apple should consider adding goodies like these to future iMovie revisions; while iMovie is a terrific tool, it doesn't help teach technique.

Also keep in mind that your subjects should move, not your camera. Nausea-inducing camera work is a common flaw of amateur videos. Too many people mistake a video camera for a fire hose: they sweep across a scene, panning left and right and back again. Or they ceaselessly zoom in and zoom out, making viewers wonder whether they're coming or going.

A better practice is to stop recording, move to a different location or change your zoom setting, and then resume. Varied camera angles and zoom settings makes for a more interesting video. If you must pan—perhaps to capture a dramatic vista—do it slowly and steadily.

And vary shot lengths. Your movie will be more engaging visually if you do. Use longer shots for complex scenes, such as a wide shot of a city street, and shorter shots for close-ups or reaction shots.

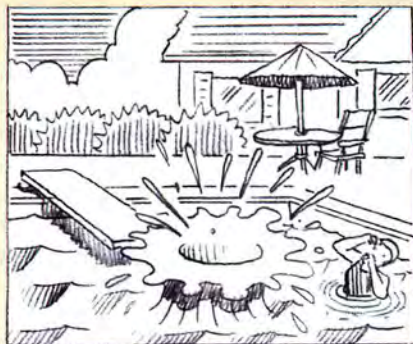
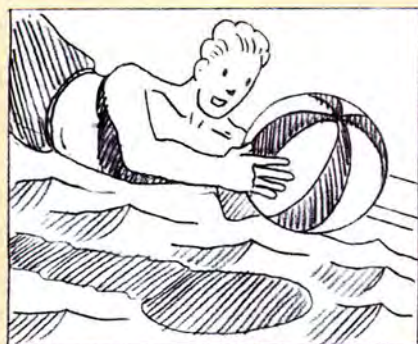



### Adding Polish: Transitions and Titles

Text titles and visual transitions can add a professional touch to your project. Titles can help set the stage by describing a place or a scene, and of course, they give credit where credit is due. And visual transitions, when used sparingly, can be pleasant alternatives to jarring cuts.

Transitions can even help tell a story. For example, a cross-dissolve—one clip fading out while another fades in—can imply the passage of time. (Imagine slowly dissolving from a nighttime campfire scene to a campsite scene shot the following morning.) Similarly, iMovie's Push Right transition, where one clip pushes another out of the frame, is a visual way of saying "meanwhile . . ."—imagine using this transition between a scene of an expectant mother in the delivery room and a shot of her husband pacing in the waiting room, chain-smoking nervously. (OK, so this is an old-fashioned maternity movie.)

**Titling Tips** To superimpose title text over a specific clip, select the clip before opening the Titles palette. Be sure to choose a text color that adequately contrasts with the clip's contents. If your movie will be viewed on an analog television, you'll get the best results with chunky fonts that remain legible despite the TV's limited resolution. For example, Arial Black works better than Times, which has ornamental serifs that can break up when viewed on a TV set. (For more information on creating titles, see the sidebar "Roll Credits.")

**Inserting a Clip between a Transition** You've added a Push Right transition to that maternity movie, but then you decide you want to insert a new clip—a shot of the doctor striding down the hospital hallway. If you drag the new clip to the Clip Viewer, you'll notice that iMovie doesn't open a space in which to drop it. That's because inserting a clip between two clips connected by a transition

is a two-step process. First, delete the transition by clicking on it and then pressing the delete key. *Now* you can insert the new clip.

**Updating Titles and Transitions** Change your mind about using a particular font, title, or transition style? To change a title or transition, first click on it in the Clip Viewer. Make the changes, and then click on the Update button in the Titles or Transitions palette in the Effects palette.

**Some Background on Rendering** When you create a title or transition, iMovie must create its video frames. This *rendering* process takes time and memory; you'll notice that iMovie

slows down when it's taking place. Avoid adding multiple transitions or titles in rapid-fire succession—this not only slows iMovie to a crawl but also might cause an error message saying there isn't enough memory to add anything until rendering is complete. To gauge how long the wait will be, look at the window that contains the transitions or titles you've added: a little red progress bar shows how far along rendering is.

**Improving on a Good Thing** The cross-dissolve is one of the most often used transitions, perfect for creating a graceful segue between scenes and for implying the passage of time. Alas, iMovie 1.0's cross-dissolve transition adds an undesirable slow-motion effect to clips. Apple fixed this in iMovie 1.0.1, a free update (available at [www.apple.com/imovie/](http://www.apple.com/imovie/)).

While you're downloading the iMovie 1.0.1 updater, also grab the iMovie Plug-in Pack—it adds six title styles and eight transition effects. Just remember to use these spices judiciously.

### Listen Up: Sound Advice

iMovie's audio features are weak. You can't, for example, replace one clip's audio track with another's. This is a common technique in *cutaways*—imagine seeing Barbara Walters nod knowingly while you're hearing Fabio describe what kind of tree he'd like to be. Despite this and other limitations, there are still a few sound tricks you can perform.

**Adding Music** If you have a scene with less-than-gripping audio—the unintelligible din of a party, for example—consider adding a music soundtrack. In iMovie's Audio Viewer, lower the scene's audio levels until they're quieter than the music but still audible. If the clip's audio is genuinely horrific—nothing but outdoor wind noise, for example—mute it entirely.

**Sound and Transitions** You have lowered a clip's volume or checked its Fade In box. Then you add a transition before the clip.

When you play the movie, the transition contains a brief blast of the clip's audio at full volume—not good. The solution: Select the transition and then turn its volume down partway or all the way.

**Working Around Volume Limitations** A common video-production technique is varying a clip's volume levels to fit around a music soundtrack or other audio. Aside from fading in and out, iMovie doesn't let you vary a clip's sound level. But there's a work-around—split the clip at the point where you want to change its level (choose Split Clip At Playhead from the Edit menu). You now have two clips with levels you can adjust independently.

## MOVIEMAKING FOR ALL USB MACS

**Y**ou don't have an iMac DV or a DV camcorder? You can still be a part of the moviemaking trend. Several companies also offer video-capture systems that work with other iMac models—and indeed, with any USB Mac. These products are designed for use with analog video gear, such as VHS or Hi8 camcorders.

**Avid Cinema for Macintosh with USB** This \$299 hardware-and-software bundle from Avid Technology (800/949-2843, [www.avidcinema.com](http://www.avidcinema.com)) is the best non-DV editing system available for USB Macs. The Avid Cinema software is more powerful than iMovie and just as easy to learn (see *Reviews*, August 1999). The accompanying USB capture hardware enables you to capture full-motion video, but you can't transfer your final product to videotape: you must view it on the Mac's screen or transfer it to an old AV Mac that has video-output features. You can, however, export to a wider array of video formats than iMovie supports, including RealNetworks' RealVideo G2, the most popular format for streaming Web video.

**InterView** Costing just \$99, XLR8's (888/957-8867, [www.xlr8.com](http://www.xlr8.com)) the InterView combines USB analog capture hardware with Strata's powerful, often complex VideoShop editing software. VideoShop is far more capable than either iMovie or the Avid Cinema software, but the InterView's lack of printed documentation makes it difficult to learn.

**MyTV/FM** This \$200 translucent blue box from Eskape Labs (925/249-6500, [www.eskape.com](http://www.eskape.com)) gives your USB Mac a cable-ready TV tuner and FM stereo tuner—and can capture video. The included EskapeTV software lacks editing features, but if you use QuickTime Pro to export video as DV streams, you can use iMovie for editing and exporting.



**Expanding Your Soundscape** Apple has posted a page of free sound effects and music clips—animal noises, crowd sounds, wind and weather, and much more ([www.apple.com/imovie/freestuff/](http://www.apple.com/imovie/freestuff/)). You can also add any AIFF sound file to iMovie's Sounds palette: just stash the file in the Sound Effects folder, which is tucked inside the iMovie folder's Resources folder.

### It's a Wrap: Exporting Your Movie

You've finished your epic—now what? You decide. With iMovie's Export Movie command, you can record it to videotape and show it to local friends and family, or save it as a QuickTime movie and post it on your Web site for all the world to see.

**End with Black** When exporting to videotape, iMovie lets you add a few seconds of black before the movie begins. Unfortunately, it doesn't let you add black *after* the movie. When your movie ends, you're jarred back to the camcorder's blue background. To add some black, use an image-editing program to create an all-black PICT file whose dimensions are 720 by 480 pixels—these are the dimensions of a DV movie frame. (You can also download an all-black file from Apple's free-stuff page, mentioned previously.) Then import this image into your project and drag it to very end of the timeline.

**Export to QuickTime** iMovie provides several presets for exporting a project as a QuickTime movie, each aimed at common tasks, such as sending the file via e-mail or posting it to a Web site. You can also specify your own settings by choosing Expert from the Export Movie dialog box's Format pop-up menu. For example, if you're going to post your movie on the Web and want to make for a faster download, you might opt for a mono soundtrack instead of a stereo one. (Less sound



means a smaller file size.) Or you might prefer to use the Cinepak video-compression scheme for broader compatibility—iMovie's default scheme, Sorenson Video, isn't supported by older versions of QuickTime. (To learn more about the art of video compression, visit Terran Interactive's Codec Central site, at [www.codeccentral.com](http://www.codeccentral.com).)

### The Last Word

The DV format and FireWire interface have transformed video production, dramatically lowering the price and hardware requirements for creating professional-quality video—thus making it easier for the rest of us to tap our creative juices, preserve our family memories, promote our businesses and organizations, or just play Hollywood. By building FireWire into the iMac DV family and creating iMovie, Apple has made digital-video editing more accessible than ever. (And the company has again inspired Microsoft to Think Similar: last December, Microsoft announced that it would begin shipping a DV-editing program called Windows Movie Maker in a future Windows release.)

If you want to explore more sophisticated moviemaking applications, see the online sidebar, "Beyond iMovie," at [www.macworld.com/2000/04/features/](http://www.macworld.com/2000/04/features/).

Of course, great gear doesn't guarantee great movies. That requires practicing the same cinematic storytelling techniques that go back to the days of flammable film. Learn those basics, and you'll go from making moving pictures to making movies. **m**

Contributing Editor JIM HEID ([www.heidsite.com](http://www.heidsite.com)) has been making home movies since 1978 and editing desktop video since 1991.

## ROLL CREDITS



You can use any TrueType or PostScript font on your system and a variety of styles to create titles. The following walks you through iMovie's Titles palette.

- A** This is a small preview of the title. To update it, click on the current title style. To view a large preview in the Monitor window, click on the Preview button. To add the title to your project, drag the small preview to the Clip Viewer's timeline.
- B** When changing an existing title, apply your changes by clicking on the Update button.
- C** Use this slider to adjust the title's duration. For some styles, this slider adjusts scrolling speed.
- D** Normally, iMovie superimposes the title text over the currently selected clip. To create a simple black background instead, select the Over Black option.
- E** With some title styles, you can click on these tiny arrows to specify text alignment and scrolling direction.
- F** Type or paste the title's text here. In title styles that provide multiple text boxes, you can jump from one box to the next by pressing the tab key.



# PowerPrint® Adventures ...the Great PC Printer Rescue

REESE CYCLE HURLS HIS OLD PC PRINTER INTO THE TRASH.

IT'S TOO BAD MY OLD LASER PRINTER WON'T WORK WITH MY NEW MAC.

GARBAGE CHUTE

PLUNGING TO ITS END, THE DOOMED PRINTER KNOWS HE STILL HAD PAGES TO PRINT.

HELP ME, POWERPRINT GIRL!

POWERPRINT GIRL SWOOPS IN AND RESCUES THE PRINTER FROM A PREMATURE DEMISE.

THAT WOULD HAVE BEEN A WASTE! WITH POWERPRINT, YOU CAN CONNECT YOUR MAC TO VIRTUALLY ANY PC PRINTER.

ONCE AGAIN, POWERPRINT GIRL SAVES THE DAY...AND A PRINTER.

YOU SAVED ME A BUNDLE! WELCOME BACK OLD FRIEND!

THANKS POWERPRINT GIRL. I THOUGHT I WAS A GONER!

...TUNE IN NEXT TIME WHEN POWERPRINT GIRL RESTORES CONNECTIVITY IN THE PRINTMOSPHERE

SERIAL, USB AND ETHERNET VERSIONS AVAILABLE



**I N F O W A V E**  
 To get PowerPrint, visit your Apple reseller, contact Infowave at 800.817.9158 or visit [www.infowave.com/print](http://www.infowave.com/print)

PowerPrint...because a good printer is a terrible thing to waste!



Circle 32 on card or [www.macworld.com/getinfo](http://www.macworld.com/getinfo)

All trademarks or registered trademarks are property of their respective owners.





# CAMCORDER

## Casting Call

*Macworld Lab Tests  
5 Affordable  
Digital Video Cameras*

**W**e're in the midst of a revolution, and this one will *definitely* be televised. Long established at the high end, consumer-level desktop video has been a long time coming—but it's finally here. And just as scanners and laser printers propelled desktop publishing, digital video (DV) cameras make videotaping easier and editing your footage more affordable.

Whether your goal is to immortalize your kid's school play or to shoot a feature-length movie à la *The Blair Witch Project*, a DV camera will yield far better footage than you could ever get with a consumer-grade analog camcorder. With 500 lines of horizontal resolution, DV formats have twice the resolution of VHS and 8mm film's 250 lines, and 25 percent more than Hi-8's 400 lines. In addition, DV provides much better color fidelity with far less color bleeding and noise than traditional analog con-

sumer formats. Best of all, some of these new camcorders now cost less than \$2,000 and sport interfaces that make it easy to get your footage onto your Mac, where you can edit and enhance it (see the accompanying feature, "Home-Movie Magic").

We looked at five digital video cameras: the Sony DCR-TRV103, DCR-PC1, and DCR-TRV10; the Canon Elura; and the Panasonic PV-DV910. They range in price from \$999 to \$1,799 (see the table, "5 DV Cameras Compared," for details about each model). To determine image quality, we performed a number of tests under controlled studio lighting and outdoor lighting. In addition, we shot still images with each camera and compared these to the same images from a low-cost digital still camera. A panel of experts examined all the footage and images to decide on quality. We also com-

by Ben Long



pared the cameras' ergonomics and evaluated the features a typical Mac user would need to shoot the best-quality video.

### How It Works

The problem with video is it takes up *a lot* of room—a single minute of video contains about 210MB of data. And anyone who's ever duplicated a file on a Mac knows that the average computer can't move huge amounts of data around quickly.

**DV Lowdown** In the past, if you wanted to work with video on your Macintosh, you had to get specialized—and *expensive*—hardware that not only took care of digitizing a video signal but could also compress it for storage on a very fast hard drive array.

Not so with a DV camera: unlike a traditional analog camera, it doesn't store an analog signal on tape. Rather, a DV camera digitizes and compresses a video signal and stores a digital stream on tape, in a process similar to writing a computer file to a tape drive. With all of the compression hardware in the camera rather than on a special video card, you need only a speedy processor, a good-size hard drive, and a FireWire interface. The speedy interface known to Mac users as FireWire (technically IEEE-1394, and i.Link in Sony's nomenclature) is now standard on most desktop Macs. This previously missing link makes it possible to move video into and out of your Mac without expensive digitizing hardware (see the sidebar "Getting Connected" for details).

**Types of Tapes** The most popular DV format for less expensive cameras is MiniDV. Although the MiniDV, DV, DVCam, and DVCPro formats all provide the same image quality, MiniDV tapes and hardware are usually much cheaper. We looked at four MiniDV cameras, all equipped with FireWire interfaces. For users who already have an investment in 8mm or Hi8 equipment, Sony produces a proprietary Digital8 format that, in addition to recording in a new digital format, can play back regular 8mm and Hi8 tapes. Though this is a great way to edit older tapes using your Mac, the Digital8 tapes have slightly lower-resolution video than DV. Our tests included one Digital8 camera, the \$999 Sony DCR-TRV103.

**The Eyes Have It** As in a digital still camera, the lens in a DV camera focuses light onto a charge-coupled device (CCD), a grid of light-sensing electrodes that acts as the camera's eye. The size of the CCD has a lot to do with the resolution and sharpness of your final image. This feature didn't differentiate the cameras we tested, however. They all have 1/4-inch CCDs, and even though the pixel count ranges from Canon's 380,000 to 680,000 on the Sony DCR-PC1 and DCR-TRV10, image resolution doesn't vary because of the way these cameras sample and process image data.

### Quality Counts

No matter what you choose to buy, the high resolution of the DV specification ensures image quality that would have been unaffordable just a few years ago. As with any type of camera, final image quality depends largely on the quality of the optics. In other words, a DV camera with a better lens will do a better job of focusing an image onto the camera's sensor.

**Through the Looking Glass** Sony and Canon both equip their cameras with high-quality lenses, which produce excellent detail and sharpness. Our jury found that the \$1,799 Canon Elura and the more expensive Sony models, such as the \$1,699 DCR-PC1 and the \$1,799 DCR-TRV10, produced images with much better detail than the \$1,100 Panasonic PV-DV910 or Sony's cheaper DCR-TRV103 Digital8 camera. This is no surprise, given that both Sony and Canon put better-quality lenses on their higher-priced cameras.

All digital cameras apply sharpening to their images, just as you might apply sharpening to a picture in an image-editing program. Although sharpening can greatly improve image detail, it can also have some unfortunate side effects. The Sony DCR-TRV10, for example, has a bad tendency to *oversharpen* its images, resulting in lines with severely jagged edges or, in some cases, lines that appear to flicker and blink. Our jury found that the Panasonic PV-DV910 produced fewer sharpening artifacts than any other camera we tested. However, if detail is important to you, be aware that the PV-DV910 produces slightly soft images. The Sony DCR-TRV103 and DCR-PC1 and the Canon Elura all struck a good balance, sharpening details without creating jagged edges and annoying artifacts.

Color reproduction varied significantly from camera to camera, although the Sony models consistently produced less saturated colors with a somewhat bluish, cold tone. Our jury found that Sony's cameras also tended to produce bands of slight hue

change when shooting a complicated image with lots of fine detail. Although not too distracting, the banding was very noticeable.

Canon aims for a more saturated look, and the Elura tends to produce images with a warmer, reddish tint. If you like this warmth, the Elura will please you, though its colors are less accurate than those of the other cameras. The Panasonic PV-DV910 fared the worst in our color tests—its huge color shifts resulted in a green or blue cast that appeared and disappeared as the camera moved.

Although all of the cameras had some color quirks, in general they produced very good images. If you're used to shooting with an analog video format, the DV format's ability to show bright colors without bleeding or blurring will surprise you. And with the format's higher resolution, a DV camera produces much better detail than its analog predecessors—although annoying artifacts from sharpening occasionally crop up.

### Come In Closer

If you enjoy nature or sports photography, you know getting closer to what's going on isn't always easy—that's where the zoom lens comes in handy.

**The Better to See You With** As with the analog video cameras of old, all of the DV cameras we looked at have built-in zoom lenses that let you zoom between wide-angle and telephoto views of your action. The zoom features on our test cameras ranged from 10× on the Sony DCR-PC1 and DCR-TRV10 to 20× on the DCR-TRV103. Unless this



**Roll Tape!** Most of the DVD camcorders we looked at use MiniDV tapes (right). Sony also sells cameras that use Digital8 tapes (left).



feature is critical to your work, don't hold out for a more powerful zoom—it's more important to choose a camera with good image quality.

**Zoomin' In** All of these cameras offer a digital zoom feature in addition to their optical zoom. With this option activated, the camera digitally enlarges your image once you've passed the optical zoom limit of your lens. Just as zooming in on a picture in an image-editing program shows you a blocky, pixelated mosaic, digital zoom increases jagged lines and distortion and can turn your image into a grid of large, distorted color blocks.

The Panasonic PV-DV910, for instance, has a ridiculous 300× digital zoom that turns the family cat into an unrecognizable grid of pixels. Unless you're deliberately trying to achieve a grungy, stylized look, avoid using digital zoom and don't let a salesperson sell you a camera based on this feature.

**The Bottom Line** None of the cameras we tested provides flawless images. Overall, they do produce very good images—meaning that once you've decided which quality trade-offs you can live with, you can base the rest of your buying decision on the camera's features.

### Fantastic Features

From wacky special effects to image stabilization, today's DV cameras are feature packed. Although you may find the nifty "old-movie effect" on one camera tempting, you need to concentrate on the most essential features.

**In the Palm of Your Hand** DV cameras come in a number of sizes and form factors, and one of your first feature considerations should be the camera's ergonomics. If small size and maximum portability are important to you, take a close look at the Sony DCR-PC1, the smallest camera we tested.

Similar to the DCR-PC1, but a tad bigger, the Canon Elura has a palm-size design with about a Walkman's dimen-



## GETTING CONNECTED

**W**hen the time comes to move that precious footage onto your Mac for editing, DV cameras offer a great advantage—the IEEE-1394 standard, known to Mac users as FireWire. This standard offers potential transfer speeds of 400 Mbps, and therefore perfectly suits DV's lofty bandwidth requirements.

All of the cameras we tested include a FireWire port that provides video and audio input and output. Each camera is fitted with the smaller four-pin FireWire jack (as opposed to the six-pin one on your Mac), so you'll need a six-to-four-pin cable.

Unfortunately, not all vendors implement their FireWire interface the same way, so you may run into some compatibility problems when you use features of higher-end editing applications such as Apple's Final Cut Pro or Adobe After Effects. Most software vendors publish lists of FireWire compatibility problems, including detailed descriptions of which features won't work properly with certain cameras. If you're determined to use a particular editing package, check with the maker of your software for compatibility issues before you buy a camera.

Apple now has a list on its Web site of the DV cameras compatible with iMovie ([www.apple.com/imovie/gear](http://www.apple.com/imovie/gear)), the consumer-level desktop video-editing software bundled with the iMac DV and iMac DV Special Edition. (Apple hasn't announced any plans to make the software available for separate purchase.) All of the cameras here work with iMovie.

sions. You hold both devices upright, and they have a lens on the front and a flip-out LCD viewfinder on the side. They're ideal if small size is your main concern, but if you are used to a more traditional design, you may prefer one of the other cameras. All of them were comfortable to use, with well-placed, easy controls.

**Steady Going** Though small size is generally convenient, it can have a negative impact on shooting stable footage. The light weight of these camcorders can make smooth pans and steady shots hard to achieve. Although all include some sort of image stabilization feature, there's no substitute for a good tripod—and some cameras are better suited to tripod use than others.

While the Canon Elura lets you change tapes while it's mounted on a tripod, the Sony DCR-TRV10 doesn't. Similarly, you can't change the batteries on the Sony DCR-PC1 without first removing it from a tripod. Although this may sound trivial, while you're fussing with your camera, you might miss that great shot of your kid's first steps.

**Dropping Anchor** To offset the difficulties of holding a 1-pound camcorder steady, most vendors include either an electronic or an optical-image stabilization feature.

Electronic stabilization works by moving your image around digitally to compensate for shaking. If you shake the camera to the left, the camera moves the image in the other direction to keep the picture steady. Optical image stabilization uses special

prisms, reshaped on-the-fly to redirect the light striking the CCD—this allows the camera to compensate for slight shaking (as opposed to intentional large movements).

In the past, electronic-stabilization features could adversely affect image quality. The camera's digital futzing with your image data sometimes created artifacts and weird motions. Now, electronic stabilization provides a more stable picture than before—without harming image quality. Optical stabilization, on the



other hand, works by adjusting optics rather than by manipulating image data, so there's no concern that it will add strange artifacts to your footage.

The Canon Elura is the only camera we tested that uses optical stabilization, and it works flawlessly. The Sony cameras use an electronic image stabilization that functions equally well. In general, either option works fine.

**Juice It Up** Vendors make a lot of claims about battery life, and frequently they're true. No matter what they say, though, you're going to want extra batteries.

Plan on buying at least one extra battery, preferably a longer-life one than your camera includes. All of these cameras have AC adapters with built-in battery chargers. Unfortunately, the Elura does not let you charge batteries while providing power to the camera.

**Cause and Effect** Each camera offers a good assortment of special-effects features, such as sepia tones and mosaics, but the ergonomics, battery life, and viewfinder should weigh much more in your buying decision than esoteric features.

**User Friendly**

Though DV video cameras are very technologically sophisticated, you'll find using one no different from using an older analog camcorder.

**A View to a Kill** One important part of a DV camera is the color display. These models all have both a large, flip-out LCD viewfinder and a smaller eyepiece viewfinder. You're going to spend a lot of time looking at those tiny screens, so make sure your camera provides a sharp image that doesn't tire your eyes.

The large viewfinders are nice, but bright sunlight often washes them out, rendering them unusable. Of the cameras we

tested, the viewfinders on the Sony DCR-PC1 and DCR-TRV10 worked best in bright sunlight. Although not as strong in direct sun, the Canon Elura had the most pleasing LCD viewfinder, with smooth details and good contrast. The Sony DCR-TRV103 had the worst LCD, and—unlike all the other cameras we examined—its eyepiece viewfinder is black-and-white.

**Manual Adjustment** The modern camcorder is a wonder of automated cinematography. With autofocus, auto-iris, and auto-white balance, you can just switch it on and start shooting. However, even the best algorithms can't handle every situation, and manual control can be a lifesaver in a difficult situation such as shooting against a bright window or trying to capture fast action at a sporting event.

To make matters easier, your camera should provide manual control for focus, white balance, and exposure. Autofocus mechanisms base their settings on what's in the center of the frame. This is fine if

you always center your subject, but if you want to be more creative, you're out of luck. Say, for example, you want to shoot a friend standing at the left of a frame, with the Eiffel Tower in the background. Because your friend isn't in the middle of the frame, the camera's autofocus mechanism will most likely focus on the distant tower, rendering your friend as a blur. With manual focus, you can be sure you've framed and focused the picture just as you wish. All the cameras we tested had manual focus.

**The Blink of an Iris** Nothing is more typical of bad video footage than that overexposed, washed-out look. Unfortunately, most auto-iris mechanisms tend to expose things a little on the hot side—bright areas flare and bloom, and in those spots color may actually bleed and blur. Outdoor conditions can exacerbate this problem, and none of the cameras we tested had auto-iris fea-



**A Good Choice** All these cameras have something special to offer, but for overall balance of features, Sony's DCR-TRV10 is our Editors' Choice.

**5 DV CAMERAS COMPARED**



Company	Product	Mouse Rating	List Price	Contact	White-Balance Presets	LCD Size (in inches)	Extra Features
Canon	Elura	★★★½	\$1,799	800/652-2666 www.ccsi.canon.com	yes	2.5	Progressive-scan mode for better still quality.
Panasonic	PV-DV910	★★★½	\$1,100	800/211-7262 www.panasonic.com	yes	3.0	LP mode records 90 minutes on a 60-minute tape.
Sony	DCR-PC1	★★★½	\$1,699	800/222-7669 www.sel.sony.com	yes	2.5	High-quality Carl Zeiss lens.
	<b>EDITORS' CHOICE</b> DCR-TRV10	★★★½	\$1,799	800/222-7669 www.sel.sony.com	yes	3.5	Memory Stick stores still images; Nightshot mode for low-light shooting.
	DCR-TRV103	★★★½	\$999	800/222-7669 www.sel.sony.com	yes	2.5	Nightshot mode for low-light shooting; reads 8mm and Hi8.



tures that could handle a difficult backlit situation. Although Sony and Canon provide exposure presets, a manual exposure control is best for difficult situations.

**Bright Lights** How a camera reproduces white varies greatly depending on the light conditions in which you are shooting. If the *white balance* of the camera is not set properly, all of the other colors will be off—usually they shift to red, blue, or green, making Mom’s chiffon pie look more like, say, key lime. Although most cameras provide good auto-white balance controls, they’re not always accurate in mixed lighting situations—for example, a fluorescent-lit room with daylight streaming through a window. All of these cameras provide manual white balance.

**Fast Action** Manual shutter-speed control is a great tool for shooting fast action such as Little League games. At higher shutter speeds, the camera can stop fast-moving action, resulting in sharper detail in each video frame. On the downside, because high shutter speeds remove a lot of motion blur, your video can have a too-sharp, stroboscopic look.

Of the cameras we tested, only the Canon Elura and Panasonic PV-DV910 provided manual shutter speed. Both cameras let you select shutter speeds ranging from 1/60 to 1/4,000 of a second. If you want total control, the Canon and the Panasonic provide better manual features than any of the Sony cameras we reviewed.

**Be Still, My Heart** In addition to the usual video features, all of these cameras can shoot still images. Simply frame the shot and capture your image, and the camera writes 7 seconds of that single frame onto tape. The cameras can also record audio while saving a still, letting you provide simple commentary or narration.

Two of the cameras we tested include extra still-image features. The Canon Elura shoots its stills using a progressive scan mode (scanning the image in a single pass instead of two), which produces stills free of the banding artifacts that sometimes afflicted the other cameras. The Sony DCR-TRV10 stores all of its stills on a Memory Stick—Sony’s proprietary flash memory technology. This saves tape, plus you can easily sort and delete images on the Memory Stick or download them to your computer using a special reader.

If you really want to shoot still images, buy a still camera.

None of the cameras we tested produce images as good as those of a low-end, \$300 digital still camera. Certainly, none of the images provide enough resolution for printing, and all suffered from compression artifacts.

### Macworld’s Buying Advice

All of the cameras we tested are good units that provide fine results. If cost is your primary concern, the Panasonic PV-DV910 offers a good price/performance balance. If your main interest is maximum portability, either the Sony DCR-PC1 or the Canon Elura is the way to go. Though the DCR-PC1 earns extra marks for its built-in mike and headphone jack (see the online sidebar, “Sound Advice,” at [www.macworld.com/2000/04/features/](http://www.macworld.com/2000/04/features/)), the Elura has better manual controls and an S-Video input for dubbing from other tape formats. Finally, if you’ve got a lot of 8mm or Hi8 footage you’d like to edit or view, the Sony DCR-TRV103 is your best choice, though you’ll sacrifice a bit of quality, compared with a MiniDV camera’s results. In the end, the Sony DCR-TRV10 provides the best all-around DV solution. Though some frustrating oversharpening artifacts plague this device, it has the best balance of picture, feature set, size, and ergonomics.

The good news is that all these cameras offer quality far better than the typical analog camcorder’s, so what you see will pleasantly surprise you. **m**

BEN LONG is a coauthor of the forthcoming *Digital Filmmaking Handbook* (Charles River Media). Macworld Lab testing was supervised by Jeffry K. Milstead.

### EDITORS’ CHOICE

 **Sony DCR-TRV10** For less than \$2,000, this DV camera offers an excellent balance of features. **Company:** Sony Electronics (800/222-7669, [www.sel.sony.com](http://www.sel.sony.com)). **List price:** \$1,799.

#### REAL PRODUCTS REAL RATINGS

**Reviews you can trust** *Macworld* rates only final shipping products, not prototypes. What we review is what you can actually buy.

Input/Output	Manual Controls	Format	iMovie- Compatible	Optical Zoom	Comments
FireWire, S-Video in/out, composite out	Focus, exposure, shutter speed, white balance	MiniDV	yes	12x	Excellent manual controls; includes S-Video in; no mike or headphone jack.
FireWire, S-Video out, composite out, mike input, headphone jack	Focus, exposure, shutter speed, white balance	MiniDV	yes	18x	Excellent manual controls; doesn’t oversharpen; bad white-balance presets.
FireWire, S-Video out, composite out, mike input, headphone jack	Focus, exposure, white balance	MiniDV	yes	10x	Extremely portable, comfortable; annoying audio hum.
FireWire, S-Video out, composite out, mike input, headphone jack	Focus, exposure, white balance	MiniDV	yes	10x	Excellent balance of features; bad oversharpening artifacts.
FireWire, S-Video out, composite out, mike input, headphone jack	Focus, exposure, white balance	Digital8	yes	20x	Backward compatibility with 8mm and Hi8; slightly lower res than DV.



# E-mail

Find an E-mail Program That Fits  
the Unique Way You Correspond

# for Everyone

**D**ESPITE THE ILL-INFORMED doom and gloom you might have read in the media, we Macintosh users don't lack software, particularly when it comes to the many choices available for reading e-mail. At least a dozen Internet e-mail programs are in use today on Macs across the land.

This embarrassment of riches means you don't have to settle for what came with your computer or what your cousin recommends. You can pick *your* perfect e-mail program from among the ranks. If you're unhappy with your current one, or if you just want to see how the competition stacks up, read on. Whether you get 2 e-mail messages a day or 200, we've found an ideal program for the way you work. (See the table "11 E-mail Programs Compared" for ratings.)

## The Casual Correspondent

Most people have modest needs that any e-mail program can meet. They get

a few messages per day or per week, and then they delete them. If you're a casual correspondent, you probably use a program that came with your Mac, such as America Online, Apple's Cyberdog, Apple's EMailer (formerly Claris EMailer), Microsoft Outlook Express, or Netscape Communicator, or a program from your ISP (Internet service provider), such as Eudora Light.

**Stick With It** If you receive just a few messages, it's probably best to stick with what you've got. It doesn't really matter if your e-mail program is now defunct—as in the case of Apple's Cyberdog and EMailer—or if you're using a version that's several releases old, such as the widely distributed Eudora Light and Outlook Express 4.5. If you aren't having problems, why go to the trouble of setting up and learning a whole new application?

**Free and Easy** Ah, but what if the few messages you *do* receive contain essential baby pictures that your e-mail

program won't display? Even people with limited needs might want to switch e-mail programs to take advantage of niceties such as seeing graphics in messages or the ability to click on e-mailed URLs to visit Web sites. Since you won't need advanced features and you want to avoid any hassles, switch to a free program that will help with the process of transferring such information as your address book (see the sidebar, "Making a Smooth Switch," for tips). You also might consider a program recommended by someone who can help you with conversion and answer your questions.

We recommend Microsoft Outlook Express 5.0 (see *Reviews*, March 2000), since it's free and easily obtained, and you can get help with it from both Microsoft and an active user community. It imports mail, addresses, filters, signatures, and accounts from earlier versions of Outlook Express and Eudora, as well as from Netscape Com-





by Adam C. Engst

municator 4.0 or later, Apple's Emailer 2.0, and text files.

**THE CASUAL CORRESPONDENT'S IDEAL E-MAIL PROGRAM:**

What you've got or Microsoft Outlook Express 5.0

**The AOL Masses**

As popular as America Online (AOL) is, its e-mail capabilities lag far behind those of any other program we looked at. The features it does have are difficult to find, and almost every window packs loads of advertising on top of your monthly fee. If you're disenchanted with AOL's e-mail capabilities, you have three options. You can stick with it, find a copy of Apple's Emailer for sending and receiving AOL mail, or get a separate e-mail account elsewhere.

**Remain LoyAOL** Despite all its drawbacks, you may want to stick with AOL if you receive little mail, and particularly if most of it comes from other AOL users, who can easily include

graphics, styled text, and clickable URLs you can't receive from or send to other Internet users. One recent addition that might make the service more attractive is AOL Mail on the Web, which lets you read your AOL mail via any Web browser, with roughly the same features the AOL application offers.

**Try Emailer** Despite the fact that Apple hasn't updated Emailer in some time and the program has little if any future, it's still easy to recommend to anyone who seeks to gain more e-mail power while retaining a well-known AOL address. (Because of prior business agreements, Emailer is the *only* alternative e-mail program for Mac that can read AOL mail.) It provides powerful filters for managing quantities of mail and more. Visit the Unofficial Emailer Page, at [www.macemail.com/emailer/](http://www.macemail.com/emailer/), for information on Emailer, including where to purchase a copy.

**Look Outside** Finally, remember that AOL provides a more or less com-

plete Internet connection via AOL Link, over which you can run most TCP/IP Internet programs, including Microsoft Internet Explorer and all the e-mail programs mentioned here. So you could set up a free POP e-mail account elsewhere—for example, with Apple's new Mac.com e-mail service ([www.apple.com](http://www.apple.com))—and use one of the e-mail programs we mentioned previously to read mail over your AOL-based Internet connection. (What's POP? See the table "Know Your E-mail Lingo" for a translation.)

**THE AOL MASSES' IDEAL E-MAIL PROGRAM:**

AOL's e-mail software or Apple's Emailer 2.0

**The Aesthete**

E-mail used to be ugly, and even today you can't be sure recipients will see exactly what you intended. That's a problem if you're planning on sending your perfectly formatted résumé to potential employers via e-mail.

ILLUSTRATIONS BY MICHELLE CHANG



But some modern e-mail programs support HTML-styled mail, which lets you send and receive messages that look just like Web pages, with text in different fonts, sizes, styles, and colors, not to mention inline graphics and text links to URLs. Also, if you use Netscape Communicator to browse the Web, you can e-mail especially interesting pages, such as a review of that oh-so-awful 1978 *Star Wars Holiday Special*, to friends.

If you really care what your e-mail looks like, you have three main choices: Eudora, Outlook Express, and Netscape Communicator. All three support HTML messages, but for the ultimate in styled elegance, go with Communicator. Thanks to its built-in Web browser and page-creation capabilities, you can read and create complex layouts.

Be aware, however, that Communicator's stylistic capabilities are useful only if you *know* that your recipients also use Communicator—for example, if you work at an organization that requires everyone to use Netscape. Otherwise, Eudora and Outlook Express offer layout and display engines that you may find useful in spite of their lesser capabilities.

**Ascetic Aesthetics** Perhaps you eschew styles altogether and spend your time tweaking characters and spaces for perfect formatting of ASCII tables, where you need numbers to line up. Or you use ASCII graphics created entirely from characters, such as those you can make with Sig Software's shareware program Email Effects ([www.sigsoftware.com](http://www.sigsoftware.com)).

Although those who read mail in a proportional font may still miss your painstaking formatting efforts, if you rely on characters instead of HTML for for-

matting, more people will see what you want them to. For example, you could indicate underlining with underscores preceding and following the appropriate word or phrase. E-mail programs can aid your quest for well-formatted e-mail by removing unnecessary HTML styles and manipulating the text of your messages.

Several programs have useful features for avoiding styles. Eudora can strip styles from messages before sending them (this removes pasted-in graphics as well), and can prompt to see if you want to do this for each message, so you can easily remove unneeded styles from replies whose originals contained styled text. Netscape Communicator provides a check box that lets you indicate whether a contact in the Address Book can read HTML mail. If not, Communicator resorts to plain text.

Eudora and Outlook Express both offer tools for manipulating text while editing, so you can wrap or unwrap paragraphs, quote text, and achieve the look you want in your messages. However, the \$79 Mailsmith from Bare Bones Software (see *Reviews*, December 1998) outdoes both with similar tools plus a full search-and-replace capability unique among the programs we explored. Mailsmith isn't necessarily easy to use, but if you need these features, it can't be beat.

#### THE AESTHETE'S IDEAL E-MAIL PROGRAM:

Netscape Communicator 4.7 or Bare Bones Software's Mailsmith 1.1.5

#### The Traveler

We've all suffered from falling out of touch on the road: you can't retrieve the phone number of a person you're sup-

posed to contact during a trip, you learn too late of a canceled meeting, and worse. Despite Internet communications, we're traveling more than ever before for work, for play, and between home and the office. We're often expected to stay in touch via e-mail the entire time.

**Get on the IMAP** If you need to read e-mail and access archived messages from home and work, and potentially from multiple work locations, it's time to chat with your network administrator about IMAP, or Interactive Message Access Protocol. Most people are used to downloading mail to their Macs and then reading and filing it locally. With IMAP, in contrast, mail lives on the server, and you simply read a temporary copy on whatever Mac you're using. This approach is perfect if you need to access your stored mail from multiple locations. Many organizations don't provide IMAP support, so make sure you can use it.

Five of the programs we looked at support IMAP: Eudora, Cyrusoft's Mulberry, Netscape Communicator, Outlook Express, and CTM Development's PowerMail. (We looked at the public beta version of Mulberry.) Despite Mulberry's cluttered interface, it offers the best IMAP support.

Mulberry's speed at retrieving IMAP mailbox lists and messages particularly sets it apart, as does the way it lets you choose to display only certain message types. It also supports a disconnected mode, which makes reading IMAP mail possible while you're using a PowerBook on a plane. If you want to read mail from both your work IMAP account and the personal POP account you use at home via the same program, any of the programs above will work except Netscape Communicator, which restricts you to either IMAP or POP.

**POPPing Around the Country** IMAP works best if you have a fast network connection at all times; if you're traveling with a PowerBook and connecting via modem, an e-mail program that retrieves mail to your PowerBook via POP will work more smoothly. You can read and write mail offline on the plane; once you arrive at your destination, just connect again to send and receive new messages. POP is especially useful if you want to tell your e-mail program to skip messages larger than a certain size when connecting via a slow modem on the road. Eudora offers the best, most flexible POP support. It pro-

### Know Your E-mail Lingo

ASCII mail	American Standard Code for Information Interchange mail. The term ASCII basically means "plain text." ASCII e-mail messages use just the letters, numbers, and characters on your keyboard. ASCII mail can't display any particular fonts or styles.
HTML mail	HyperText Markup Language mail. Messages sent as HTML mail can use different fonts, styles, sizes, and colors, plus inline graphics, just like what you see on Web pages.
IMAP	Interactive Message Access Protocol. IMAP is a method of retrieving e-mail that stores all of your messages on the IMAP server; you read and respond to temporary copies of messages downloaded to your Mac.
POP	Post Office Protocol. POP is a common method of retrieving Internet e-mail that by default downloads all your messages from the POP server to your Mac for reading and storage.
Web-based e-mail	Web-based e-mail lets you read your mail within a Web browser, rather than in a dedicated Macintosh e-mail program.



vides easy methods for checking only certain accounts, canceling automatic checks while you're using the Power-Book's battery, and managing mail left on the server.

**Home, Home on the Web** What if you don't own a PowerBook or don't want to lug it around? Set up an account with one of the large Web-mail providers, such as Microsoft's Hotmail ([www.hotmail.com](http://www.hotmail.com)) or Yahoo Mail ([mail.yahoo.com](http://mail.yahoo.com)). You can access both from the Web while you're on the move and use them to read a small amount of mail from a POP account. When you're home, you can access Yahoo Mail with any standard POP-based e-mail program, and Hotmail with Outlook Express 5.0.

Web-based services such as ThatWeb ([www.thatweb.com](http://www.thatweb.com)) let you access your existing POP or, less commonly, IMAP account via the Web, without the several-megabyte storage limitations of Yahoo Mail and Hotmail. If you have a POP account, you may find one of these services useful for checking in quickly (see [www.emailaddresses.com](http://www.emailaddresses.com) for a list), though you won't have access to stored mail.

Keep in mind that you're essentially giving your e-mail password to the company running the Web-mail program, so make sure you're comfortable with its integrity and privacy policies.

#### THE TRAVELER'S IDEAL E-MAIL PROGRAM:

CyruSoft's *Mulberry 2.0* for IMAP users, Qualcomm's *Eudora Pro 4.2.2* for POP users, and ThatWeb for Web-based POP access

#### The Traffic Cop

You're the one in the office who receives general e-mail and redirects it to the appropriate recipient. You may also receive automated messages from various Internet services or from monitored servers. Far from making you feel popular, the role of traffic cop can be utterly overwhelming, as you attempt to handle vast quantities of mail that isn't even addressed to you. Automated mail is even worse, since you can probably ignore most of it—but you can't afford to miss that one message that tells you the mission-critical server just blew a hard disk.

Your two top priorities are powerful filters that can redirect mail and easily accessed support for AppleScript, since you want to spend as little time as possible rerouting messages manually. Decent search capabilities also come in



## Making a Smooth Switch

THE MOST SIGNIFICANT OBSTACLE to switching from your current e-mail program to a new one is the threat of losing the vast amount of e-mail and addresses you've stored over the years. Luckily, methods exist for moving from almost any e-mail program to any other.

Some programs, such as Outlook Express, Mailsmith, and PowerMail, recognize that they've come late to the game and provide conversion capabilities, either internally or via AppleScript scripts.

In other cases, you may have to use utility software. Refer to the table for hints on which formats different programs can import.

**CONVERSION STEPS** We can't provide conversion advice specific to every possible combination of programs, but if you follow these general steps, you'll find out whether you can move to a new program easily.

1. Visit the Web site for the program you're considering and download a demo. Every program mentioned here has an evaluation version.
2. Look in the file menu, in an included utilities folder, or within Netscape Communicator, in the hierarchical Tools menu under the Communicator menu, for menu items or utilities related to conversion. If you see a conversion option, use it.
3. If you can't find an appropriate conversion option (or the program converts messages but not addresses), visit [www.emailman.com/conversion/](http://www.emailman.com/conversion/) and see if any third-party utilities can help. In particular, check out Richard Shapiro's MailConverter and InterGuru's Email Address Conversions.
4. If no direct conversion path exists, see if you can convert the data from your program into Eudora format, then into your desired destination format. Since Eudora mailboxes and address books are just specially formatted text files, they often provide a useful interchange format.

**CONVERSION ADVICE** In general, make sure you have a current backup before starting, just in case. If you use AppleScript- or Apple event-based conversions, perform spot checks on the converted messages and addresses to make sure the conversion worked properly. And don't throw out your original data until you're positive the conversion was successful.

handy the day your boss asks exactly how many times the server has gone down.

**The Right Route** All of the more powerful programs, such as Eudora, PowerMail, and Outlook Express, can handle routing, but Mailsmith stands out with its excellent scripting support and flexible filters. Mailsmith lets you define more than two criteria (your limit with Eudora and PowerMail), and although Outlook Express offers additional criteria, Mailsmith's support for grep (an extremely powerful method of searching for text, using patterns) in filters and searches gives it the edge.

THE TRAFFIC COP'S  
IDEAL E-MAIL PROGRAM:  
Bare Bones Software's Mailsmith 1.1.5

#### The E-mail Addict

You know who you are. You check e-mail as soon as you get up, before you go to bed, and every ten minutes the rest of the day. You receive hundreds of messages every day, you save almost everything you get, and you're not even sure how many mailing lists you subscribe to. If you're still in denial, do a Get Info on the folder that holds your e-mail and find out how large it is. See what I mean? Now that you've accepted your lot in life, how can you streamline your e-mail usage?

**Eudora Euphoria** Run, don't walk, to Qualcomm's Web site and get a copy of Eudora. In the next version (in beta release at press time), if you're willing to put up with an advertisement box, you can



use Eudora for free. You can also opt for a reduced feature set without ads or pay \$50 for the full feature set without ads.

Proponents of other e-mail programs will no doubt scream about this choice for heavy e-mail users, but Eudora has the best combination of features and performance. Its filters are plenty powerful, even if they're not quite up to those in Mailsmith and Outlook Express. Searching in Eudora is fast and flexible. You can even save searches and run them later from the Find menu.

To help you avoid misspelling words when you write quickly, Eudora provides a spelling checker that marks mistakes as you type. Eudora's hierarchical menus (it also has a Mailbox window) are unusual, but they provide fast access to deeply nested mailboxes. More important is the fact that Eudora stores all of its messages in text format, an efficient and safe storage mechanism. Outlook Express, Mailsmith, and PowerMail all rely on a single mail database. This means if your hard

disk becomes corrupted and that one file gets trashed, you lose everything. Stuffing all your messages into a huge database also means inefficient backups—and you can't afford to lose your precious stored mail.

Finally, Eudora has a vast number of hidden options and features you may find invaluable in specific situations. For example, you can set Eudora to open new Web browser windows in the background when you ⌘-click on URLs—it's a great way to load a bunch of Web pages while you keep reading e-mail. You can also set Eudora to save messages you're writing, an extremely welcome backup if your Mac crashes while you're composing an important message. See [www.eudora.com/techsupport/mac/xsettings.html](http://www.eudora.com/techsupport/mac/xsettings.html) for more information and a downloadable list of settings.

**THE E-MAIL ADDICT'S  
IDEAL E-MAIL PROGRAM:  
Qualcomm's Eudora Pro 4.2.2**

### Macworld's Buying Advice

All of these programs provide at least the basics of reading and writing e-mail—the differences lie in the details, and one of the bunch almost certainly will meet your needs. If you can't decide which profile best describes you, Microsoft Outlook Express 5.0 is a good place to begin for those with relatively modest needs, and Eudora works well for beginners and those who need the utmost flexibility and power. These programs top our ratings, and both are available free in fully functional versions.

If your current e-mail program is getting on your nerves, rest assured—one of the many Macintosh e-mail programs *will* meet your needs. Just figure out what you want with the help of our profiles, make the switch, and enjoy the ease you'll gain from using the right tool for the job. **m**

ADAM C. ENGST is the publisher of the e-mail newsletter and Web site TidBits and the author of *Eudora 4.2 for Windows & Macintosh: Visual QuickStart Guide* (Peachpit Press, 1999).

## II E-mail Programs Compared

Company	Product	Mouse Rating	List Price	Contact	Imports From	Killer Features
America Online	AOL Mail 4.0	⦿⦿½	Free with AOL (\$22 per month)	800/754-0403 <a href="http://www.aol.com">www.aol.com</a>	Nothing	Parental controls
Apple Computer	Mailer 2.0	⦿⦿⦿	\$49	800/692-7753 <a href="http://www.macemail.com/emailer/">www.macemail.com/emailer/</a>	Nothing	Reads AOL mail
Qualcomm	Eudora Pro 4.2.2	⦿⦿⦿⦿	\$50 *	800/238-3672 <a href="http://www.eudora.com">www.eudora.com</a>	Nothing **	Stationery, inline spelling checker, scheduled messages, search, customizability
eWare	Green 1.0	NA ***	Free (for individual use)	<a href="http://www.eware.fr">www.eware.fr</a>	Eudora Light, Netscape Communicator, Outlook Express	Online documentation system
Bare Bones Software	Mailsmith 1.1.5	⦿⦿⦿	\$79	781/687-0700 <a href="http://www.barebones.com">www.barebones.com</a>	Mailer, Eudora, Outlook Express	Text editing, search, scriptability
Cyrusoft	Mulberry 2.0	NA ***	\$40	412/605-0499 <a href="http://www.cyrusoft.com">www.cyrusoft.com</a>	Other IMAP	Fast and powerful IMAP support
Sono Software	Musashi 3.1.1	⦿⦿⦿	\$33	<a href="http://www.sonosoftware.com">www.sonosoftware.com</a>	Eudora, text only	Mailbox view options
Netscape Communications	Netscape Communicator 4.7	⦿⦿⦿½	Free	650/254-1900 <a href="http://www.netscape.com">www.netscape.com</a>	Eudora, text only	HTML mail, integrated with Web browser
Microsoft	Outlook Express 5.0	⦿⦿⦿⦿½	Free	800/426-9400 <a href="http://www.microsoft.com/mac/">www.microsoft.com/mac/</a>	Mailer, Eudora, Netscape Communicator, Outlook Express, text only	Import, filters, mailing-list manager, address book, scriptability
CTM Development	PowerMail 2.4	⦿⦿⦿	\$49	800/424-9933 <a href="http://www.ctmdev.com">www.ctmdev.com</a>	Mailer, Eudora, Netscape Communicator, Outlook Express	Sherlock searching
CE Software	QuickMail Pro 2.0.1	⦿⦿⦿	\$40	800/523-7638 <a href="http://www.cesoft.com">www.cesoft.com</a>	Outlook Express Export File	Integration with QuickMail servers

\* Eudora 4.3, which should be released by the time you read this, will also be available for free if you agree to see ads. \*\* Qualcomm says Eudora 4.3 will import from Netscape Messenger and Outlook Express. \*\*\* Not applicable; software available as public beta at press time.



# Think Faster.

**NEW!**



FriendlyNET™ GX4 Series Gigabit Ethernet  
over copper switch



**Macworld**  
★★★★

"(The AsantéFast GigaNIC) is fast and well designed, and it includes features that may be useful in a multimedia environment."

— Macworld Magazine



FriendlyNET™ 7000 Series Gigabit Ethernet  
over fiber switch

**ASANTÉ**  
MAKING NETWORKING SIMPLE  
www.asante.com

© 2000 Asanté Technologies, Inc. Asanté, the Asanté logo, FriendlyNET, AsantéQ, and GigaNIC are trademarks or registered trademarks of Asanté Technologies. Photograph copyright Barros & Barros/The Image Bank.



## Simply the most affordable, powerful Gigabit Ethernet solutions ever.

### *Now you have a choice for high performance networking*

Move at a faster pace with Asanté Gigabit Ethernet solutions for your business. Start with our award-winning GigaNIC™ PCI adapters to seamlessly integrate your workstations and servers into departmental or corporate backbones. Upgrade your workgroup with our new FriendlyNET™ GX4 Series switch – the most affordable Gigabit Ethernet over copper solution. Or, extend your network to greater distances with the FriendlyNET™ 7000 series switch – the modular Gigabit Ethernet over fiber solution.

### *Connecting Workgroups Faster*

Introducing the most cost-effective Gigabit Ethernet solution: our new GigaNIC 1000T adapters and GX4 switches. Now move files 10x faster when you upgrade from Fast Ethernet to Gigabit Ethernet. Each Gigabit port adapts to the wiring you already installed (Cat 5 UTP) – even if you've inadvertently miss-wired your cables. AsantéQ™ link quality monitor continuously adjusts for dynamic network cable conditions – all without complex network management software or diagnostic equipment.

### *Building Bigger Networks*

Our FriendlyNET 7000 Series switches and GigaNIC 1064SX adapters combine to deliver wire-speed, switched Ethernet throughout your network – over distances up to 550 meters (1,804 feet). This complete Gigabit Ethernet over fiber solution allows you to securely transmit and receive huge files while its full compatibility with legacy Gigabit Ethernet fiber standards protects your investment.

**Visit our website to take advantage of our new low prices on the only complete Gigabit Ethernet solutions for Mac OS, Windows and Linux. Only from Asanté.**



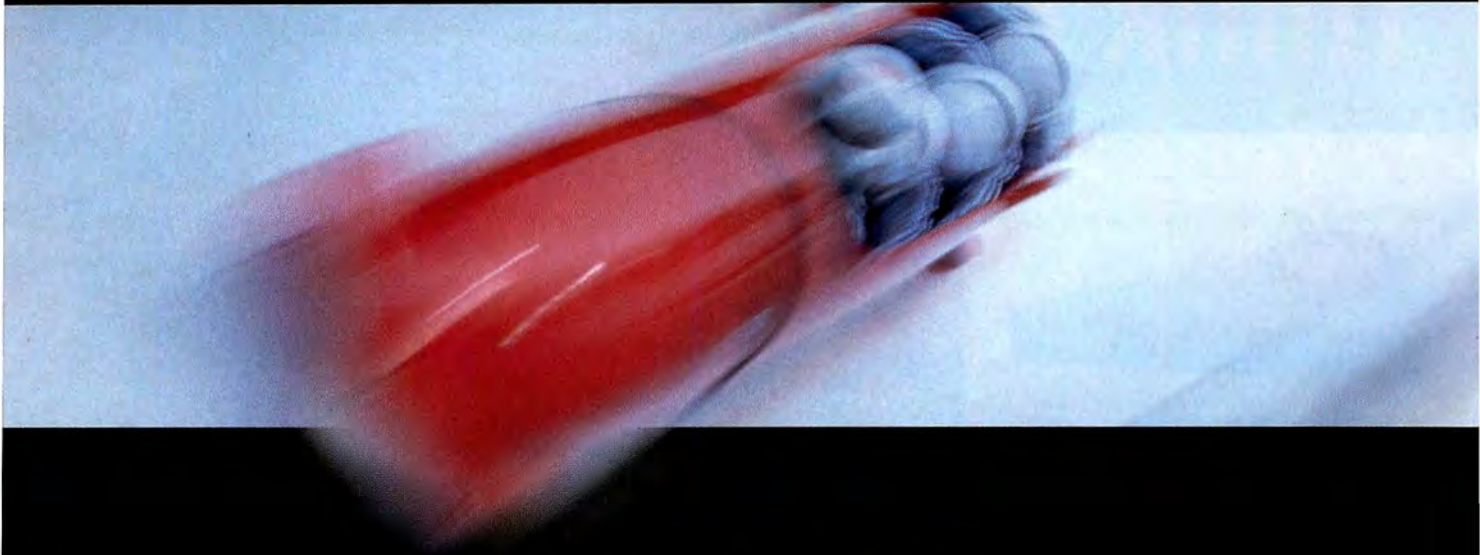

# SONNET™

## *SIMPLY FAST™*

It's about speed and time. Simply add a Sonnet processor upgrade card to your Power Macintosh or PowerBook and instantly work faster. Wherever time matters, more people depend on Sonnet. You should too. For more information, call us at 1-949-261-2800 or visit our website at:

[www.sonnettech.com](http://www.sonnettech.com)





# Secrets

## The Desktop Multiplex

THE HIDDEN POWERS OF QUICKTIME PLAYER

by Joseph Schorr

**O**K, it's official: I now watch more movie trailers on the screen of my PowerBook than I do at my local multiplex. I blame this phenomenon not on a lack of self-control but on the irresistible lure of the Internet and QuickTime 4, which together allow those movie trailers to come streaming right to me over the phone line.

Most Mac movie watching these days happens in QuickTime Player, the movie-playing app that comes with every new Mac (those of you with older systems can download QuickTime 4 from [www.apple.com/quicktime/](http://www.apple.com/quicktime/)). Unlike its predecessor, MoviePlayer 3.0, QuickTime Player doesn't just play movies; it also lets you bookmark favorites (both locally and online) for quick access and perform other movie-watching tricks.

QuickTime Player has a quirky, non-standard Mac interface, but it's replete with timesaving shortcuts and hidden features. Read on to find the best of them. After all, if you're going to waste company time watching movie previews, you might as well do it with a pro's prowess.

### Organize Your Drawer

One of QuickTime Player's most convenient features is the Favorites Drawer, where you can create links to QuickTime content on the Internet as well as to movies stored on your own computer or network. The drawer, which slides down from the bottom of the QuickTime Player



window, comes with 15 preset URLs that link to sites such as HBO, NPR, and Apple's QuickTime Showcase (offering a link to popular movie trailers). Some presets open streaming video or audio directly in QuickTime Player. Others launch your browser and open Web pages from which you can access a variety of audio and video clips. Here are a few tips for managing your drawerful of movies:

- To open or close the Favorites Drawer, press  $\mathbb{A}$ -right bracket (]) or double-click on the grooved handle at the bottom center of the drawer. You can open the drawer as wide as you want by dragging its bottom edge.

- To add any movie currently open in QuickTime Player to the Favorites Drawer, press  $\mathbb{A}$ -D. (You can add only movies actually open in the player, not Web pages that contain movies. To save those pages, bookmark them in your browser.) To add movie files you've stored locally, drag and drop them onto an open slot in the drawer.
- To rearrange items in the drawer, drag their icons to different slots. It's best to drop the icons onto open slots, since dragging a new favorite to an occupied slot removes the old one. Changing the order of icons in the drawer also

*continues*



changes the order of items in the Favorites menu. Likewise, switching the order of links in the Favorites menu (via the Organize Favorites command) rearranges the items in the drawer.

- To remove a link, drag its icon from the drawer to the Trash.
- You can create a Favorite Shortcut file—a stand-alone link to a movie—by dragging an icon from the Favorites Drawer to the desktop. The shortcut works like an alias; double-clicking on it opens the linked movie and creates an Internet connection if necessary.

**The QuickTime TelePrompTer**

The QuickTime Player application may seem like a one-trick pony. Its intended function, after all, is simply to play QuickTime movies. But lurking beneath that high-tech exterior are weird and wild functions—the automated TelePrompTer, for example.

Here's how this feature works: Drag a plain text file (one whose file type is TEXT) into the Favorites Drawer. Click on the file's icon in the drawer to open it in QuickTime Player. (This is the *only* way to open a text file in the player; the Open command won't work.) The first line of text from the file appears within the movie screen in white Geneva text on a black background (see "Easy Reader").

Now it gets bizarre. Click on the play button and the player displays the contents of the file one line at a time, like a TelePrompTer, spending two seconds on each line. You can't control scrolling speed (unless you click on the fast-forward button on the control panel), but you *can* start and stop the flow of text using standard

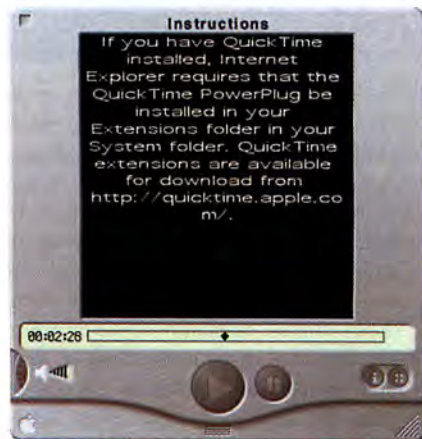

**Easy Reader** Crack open a text file with QuickTime Player and it flashes the contents back to you in stark white on black, one line at a time.

**Squander Time Efficiently**

**W**ITH ITS FUTURISTIC, SCULPTED 3-D LOOKS, QUICKTIME PLAYER IS SLICK—but at times all those buttons, indicators, and gizmos can be more hindrance than help. If you want to zip through movie trailers, MTV clips, and CNN news items at peak efficiency, there are keyboard equivalents for most QuickTime Player functions. (Many of these shortcuts also work with version 4.X of QuickTime Plugin, which can play QuickTime movies in Web pages from Microsoft Internet Explorer or Netscape Navigator.)

**A** To start playing a movie, click on the big round play button or simply double-click in the middle of the movie screen. From the keyboard, press the return key, the spacebar, or ⌘-right arrow. Press ⌘-left arrow to play a movie *backward* at normal speed.

**B** To stop a movie, click on the pause button; press the spacebar, the return key, or ⌘-period; or press the right- or left-arrow key once.

**C** To step through a movie one frame at a time without sound, click on the forward or back button or press the right- or left-arrow key repeatedly.

**D** To adjust the sound level, drag the volume-control dial or press the up arrow to increase volume or the down arrow to decrease it.

**E** To turn the sound off completely, click once on the white speaker icon near the volume-control dial or press option-down arrow. For maximum sound volume, press option-up arrow.

**F** To skip to the beginning or end of a movie, click on these buttons or press option-left arrow or option-right arrow.

**G** To open or close the Favorites Drawer, double-click on the drawer's grooved handle or press ⌘-right bracket (]).

**H** To expand or shrink the movie window proportionally, drag the resize handle at the bottom right. Shift-drag to scale the window nonproportionally.



**I** These fast-forward and rewind buttons have no keyboard equivalents, but they are useful for skipping through a movie at high speed with sound.

**J** To skip part of a movie, drag the diamond along the time bar. The counter at the left indicates the currently displayed minute, second, and frame.

**K** To get information about a movie's file size, length, and so on, click on the button with the lowercase *i* or press ⌘-I.

**L** To display or hide the dark-gray panel containing the navigation and sound controls, click on the button with four dots.

playback commands. To make the text bigger, enlarge the QuickTime Player window by dragging its lower right corner; the text scales proportionally with the movie screen and remains readable. Granted, this oddball feature won't make you more productive at the office—but

let's face it, neither will the latest streaming video from MTV. You want productivity? Launch Excel. **m**

JOSEPH SCHORR wonders who will play him in the movie version of *Macworld Mac Secrets* (IDG Books Worldwide, 1999), the book he coauthored.



## Tips, Tricks, and Shortcuts

by Lon Poole

**N**eed to install software from a floppy to a Mac that lacks a floppy drive? Tired of inserting a CD to play a game or consult an encyclopedia? You can solve these problems with disk-image files. For example, when Stephen Taylor of Castro Valley, California, got a new G4 at work, he wanted to install QuarkXPress on it. His version of the software came on CD but required an installation floppy; of course, the G4 has no floppy drive. No problem: he inserted the installation floppy into an older Mac and made a disk image using the Disk Copy utility that comes with the Mac OS. (The latest version of Disk Copy is available from Apple's Software Library, <http://asu.info.apple.com>.) He then copied the disk-image file to the G4 via the local network. After mounting the disk-image file as a disk on the G4—again using Disk Copy—he was able to proceed with the installation.

If your new Mac isn't on a local network, you can make the disk-image file on an older Mac that has Internet access, then either e-mail the file to the new Mac or transfer the file via one of the free storage sites on the Web, such as [www.freemacspace.com](http://www.freemacspace.com) or [www.aladdinsys.com/freedrive/](http://www.aladdinsys.com/freedrive/).

Daniel Vanwie of Whittier, California, uses the \$30 ShrinkWrap utility from Aladdin Systems ([www.aladdinsys.com](http://www.aladdinsys.com)) to create compressed, unencrypted, self-mounting disk-image files (with the extension .smi) from CD-ROMs. He recommends placing the resulting image file in the same folder as the application that requires it.

To make the CD image really easy to use, just record a simple AppleScript program that mounts the CD image as a disk and launches the application with one double-click. Start by opening Script Editor, a utility that comes with the Mac

OS, and clicking the Record button in a new script window. Switch to the Finder, open the CD image, and then open the application. Switch back to Script Editor and click the Stop button. The following is an example of a recorded script that mounts a SimCity 3000 CD image (SimCity3000.smi) and then opens the SimCity application (SC3 1):



```
tell application "Finder"
  activate
  select file "SimCity3000.smi" of folder
  "SimCity 3000" of folder "Applications" of
  startup disk
  open selection
  select file "SC3 1" of folder "SimCity
  3000" of folder "Applications" of startup disk
  open selection
end tell
```

To turn the script into a program, choose Save As from the File menu; in the Save dialog box, set the Kind option to Application and turn on Never Show Startup Screen. To mount the CD image and start SimCity, double-click the icon that Script Editor creates.

### Inbound from the Internet

**Q.** I use the gateway software IPNetRouter from Sustainable Softworks ([www.sustworks.com](http://www.sustworks.com)) to share an Internet connection among the computers on my local network. The gateway also creates a firewall that prevents computers on the Internet from accessing computers on my local network. Is there a way to forward incoming packets to one computer on my local network so that it could, for example, serve Web pages?

DAVID KEPHART  
Pittsburgh, Pennsylvania

**A.** Many Internet-sharing gateways can be configured to permit computers on the Internet to access a computer on your local network for a specific purpose, such as serving Web pages.

The sidebar "Inbound Port Mapping" illustrates the setup for IPNetRouter and another popular software gateway, Vicomsoft SoftRouter Plus ([www.vicomsoft.com](http://www.vicomsoft.com)).

### Set Modem Speaker Volume

**Q.** How can I edit a modem script to control the modem speaker volume? I'd like to have several uniquely named scripts that set the volume to off, maximum, and maybe a default level.

BUD WEBER  
Kitchener-Waterloo, Ontario, Canada

**A.** You can edit modem scripts with any word processor or text editor, including SimpleText. A modem-script  
*continues*



# Inbound Port Mapping

You can configure the Internet-sharing gateways IPNetRouter and Vicomsoft SoftRouter Plus to route specific types of incoming traffic to particular computers on a local network. Here, one computer (IP address 192.168.0.3) is set to get incoming FTP traffic (ports 20 and 21) and Timbuktu traffic (ports 407 and 1417 to 1420); another (IP address 192.168.0.2) is being set up to get Web server traffic (port 80).

## Configuring IPNetRouter

Choose Port Mapping from the Window menu. In the Configure Entry section of the Port Mapping window, leave the first pop-up menu set to Any (A) and leave the first IP address box (B) alone (it should contain the public IP address your

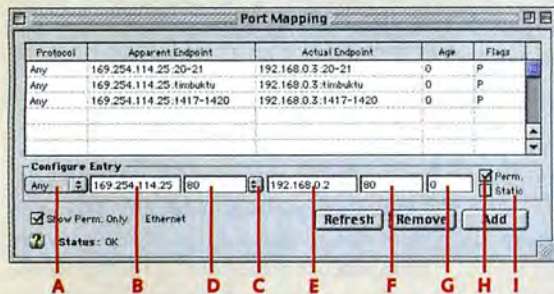

ISP assigned). Use the second pop-up menu (C) to set the TCP (or other protocol) port for the service, or type the port number directly (D). For example, for a Web server, choose http from the menu

or enter 80 in the text box. If the service uses a range of port numbers, such as 20 and 21 for FTP, type the first and last port numbers, separated by a hyphen. Next, select the second IP address box (E) and type the IP address of the local computer that will provide the service. Make sure its port number is correct (F); generally it should be the same as the port number to the right of the public IP address (D). You can ignore the entry box for Age (G), but leave the Perm. option (H) turned on to retain this mapping when you quit IPNetRouter. Don't turn on the Static option (I) unless your ISP has assigned you a static IP address. (You probably don't have a static IP address unless you connect via cable modem or DSL.) Click Add to add the port mapping

to the table at the top of the window. When you've finished mapping ports, close the Port Mapping window.

## Configuring Vicomsoft SoftRouter Plus

Choose Inbound Mapping from the Network menu. Click New Host (J) and type the IP address of the local computer that will provide the Internet service. Use the pop-up menus (K) to specify a range of TCP port numbers for the service, or enter the numbers directly (L). Click OK to finish.

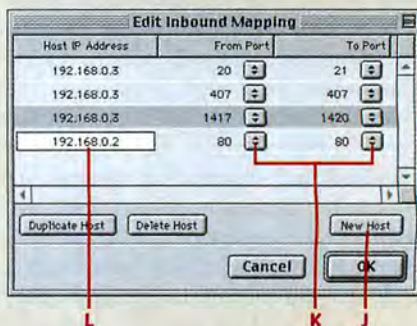

file contains plain text, though its type code is mlts, not TEXT. First make a copy of the script you want to modify. Then use a word processor or text editor that can open any type of file, such as the \$119 BBEdit or free BBEdit Lite from Bare Bones Software ([www.barebones.com](http://www.barebones.com)). Or you can use a utility such as Daniel Azuma's \$10 shareware FileTyper (<http://www.uges.caltech.edu/~dazuma/>) to change the file type code to TEXT (all caps), and then open the copy with any word processor or text editor.

Scroll through the script until you find the line @LABEL 3. Several lines below this, look for a line that begins write "AT, followed by a bunch of letters, numbers, and symbols. This is the modem-initialization string of commands (see "Edit Modem Scripts"). This string can go to the modem piecemeal, in which case the commands appear on several lines (making them easier to decipher). Lines that begin with an exclamation point, however, are not part of the initialization string. They are treated as comments, not as commands.

You don't need to know what all of the commands mean, but you can look

them up in your modem's documentation.

To set the modem volume to maximum, insert the command L3 just before V13 at the end of the initialization string. To set the volume to medium, insert L2; for low volume, insert L1; and for lowest volume, insert L0. You could insert another modem command to control the speaker: M0 to turn it off, M1 to turn it on. However, it's easier to simply set the Sound option in the Modem control panel to On or Off. Another part of the



**Edit Modem Scripts** You can edit a modem script with a text editor such as SimpleText. The modem-initialization string comes several lines below @LABEL 3 (A) and begins with the word write, not an exclamation point (B). Here, the command L3 (C) sets the modem speaker volume to its maximum level.

modem script inspects this setting and issues an M0 or M1 command.

When you finish editing the initialization string, save and close the file. If you had to change the file's type code to TEXT to work with it, change it back to mlts (all lowercase) so the Modem control panel will recognize the file as a modem script. **m**

LON POOLE answers readers' questions and selects reader-submitted tips for this monthly column. He is a coauthor, with Todd Stauffer, of *Macworld Mac OS 9 Bible* (IDG Books Worldwide, 2000).

All shareware and freeware mentioned in *Quick Tips* is available from the Macworld Online software library ([www.macdownload.com](http://www.macdownload.com)).

We pay \$25 to \$100 for tips selected for publication that discuss how to use Macs, peripherals, or software. Please include your full name and address, so that we can send you your payment. Send questions or tips to [quicktips@macworld.com](mailto:quicktips@macworld.com) or to Macworld Quick Tips, 301 Howard St., 16th Fl., San Francisco, CA 94105. All published submissions become the sole property of *Macworld*. Due to the high volume of mail received, we cannot provide personal responses.



## Sharper Images in Photoshop

EVERY SCANNED IMAGE NEEDS SHARPENING: HERE'S HOW

by David Blatner

**N**o matter how good your scanner or how crisp your original, you're certain to lose some sharpness when you digitize an image. Images from low-end flatbed scanners always need a considerable amount of sharpening. Even scans from high-end scanners need sharpening (though scanning software sometimes takes care of it on the fly). Images from digital cameras can also benefit from sharpening.

An image loses sharpness not only in the scanning process but also in the output process. Halftones (almost anything on a printing press) and dithered graphics (such as those printed on ink-jet printers) are the worst offenders. But even continuous-tone devices such as film recorders and dye-sublimation printers reduce sharpness.

Remember: You *cannot* solve the problem of blurry scans by scanning at a higher resolution. And while there's no way to bring an out-of-focus original back into focus, even a blurred original (such as a fast-moving subject) needs sharpening so it won't be blurred *and* soft.

To counteract the blurries in both the input and output stages, you need to sharpen your images. When it comes to sharpening, the key tool is Adobe Photoshop's Unsharp Mask filter, the master at making your images crisper (despite its counterintuitive name).

### The Unsharp Mask Filter

The reason you can see these printed words so clearly is that they have well-defined edges. Our eyes are extremely good at discerning edges—sharp lines between one color and another. The more marked the difference between two colors along an edge, the sharper an image and the faster we understand what we're looking at.



The Unsharp Mask filter (Filter: Sharpen) compares each pixel in your image to its neighboring pixels; the greater the contrast between two pixels, the more the program increases the contrast. This results in a halo effect around edges that appears to increase an image's sharpness (see the sidebar "Behind the Unsharp Mask Filter").

The Unsharp Mask filter can also have the undesirable effect of exaggerating texture in flat areas, noise introduced by a scanner, and artifacts from JPEG compression. Fortunately, the filter offers some controls to help you walk the fine line between sharp and ugly. The trick is to strike the right balance using the Amount, Radius, and Threshold controls in the Unsharp Mask dialog box (see the sidebar "The Simple Art of Sharpening").

### The Whens and Hows

When sharpening, you need to think about restoring sharpness lost in the image-acquisition process and introducing extra sharpness to compensate for its loss during the output process. For the highest-quality image, you need to know where your image is going before you sharpen it. Sharpening an image destined for newsprint is a different game from sharpening for the Web. Printed images, especially those at low halftone-screen frequencies (such as newsprint images), require more sharpening because subtle edge halos get lost in the translation to halftone dots. On-screen images, however, often need just enough sharpening to offset blurriness acquired at scan time.

Note that you should usually use the Unsharp Mask filter near the end of

*continues*



## Sharpening What You Want

**S**ure, I said every image needs sharpening, but that doesn't mean you want to sharpen every pixel in an image. If you examine the individual channels of most RGB scans, you'll find that often the blue channel is by far the noisiest of the three. It's also usually the one with the least-important details, so in most cases you can get away with sharpening only the red and green channels and perhaps using the Despeckle filter on the blue channel to even it out. This works best with lower Radius settings (1.4 and under). Some people convert the image to Lab mode and then sharpen the Lightness channel, even though the mode changes can cause minor degradation.

Another way to sharpen part of an image is to do it through a mask, as shown in the example here. For instance, you may want a little additional sharpening in and around the eyes in a portrait, or you might want to avoid sharpening a picture's background in order to focus attention on a foreground object. (See "Master Photoshop's Masking Tools," *Create*, June 1999, for an in-depth explanation.)



Add Layer Mask button



Before applying the Gaussian Blur filter



After applying the Gaussian Blur filter

**A**fter duplicating the background layer and selecting what you *do* want to sharpen, click on the Add Layer Mask button in the Layers palette. Feel free to touch up this mask with black and white paint to fine-tune the selection.

**R**un the Unsharp Mask filter on the duplicate layer (the image, not the mask). Only the part that is not masked appears sharpened. If the mask's edge is too hard, the transition between sharpened and unsharpened pixels will be too obvious; you can use the Gaussian Blur filter on the layer mask to soften this transition.

**T**o create a more severe contrast between foreground and background, I selected the background layer and softened it with the Gaussian Blur filter.

the image-correction process (after color correction), but before you convert from RGB to CMYK or set your minimum highlight dots. If you sharpen afterward, the Unsharp Mask filter might create unwanted specular highlights—near-white pixels blown out to pure white.

Also, if you use the Image Size dialog box to reduce the size of your image by

more than about ten percent, you'll probably need to run the Unsharp Mask filter again. That's because downsampling softens the contrast between pixels.

### Look Sharp

The Unsharp Mask filter is a powerful tool. Used well, it can give your images an extra snap that makes them jump off the page. Used badly, it can produce an

unpleasant high-contrast look. Applying the Unsharp Mask filter is definitely a skill that improves with experience. The more you experiment with the controls, the closer you'll bring your image to perfection. **m**

DAVID BLATNER is a coauthor of *Real World Photoshop 5* (Peachpit Press, 1999), including the 5.5 update at [www.peachpit.com/photoshop/](http://www.peachpit.com/photoshop/).



# The Simple Art of Sharpening

Many people get nervous when confronted with the Unsharp Mask filter for the first time. Don't worry—it's a simple three-step process. (But make sure to leave yourself an escape route by either working on a duplicate of your image or archiving the unsharpened version first.)

1. Open the Unsharp Mask filter's dialog box (Filter: Sharpen). I like to start with a significant change, so I set the Amount control (the strength of the sharpening effect) to 200 percent and the Radius control (the size of the sharpening halo) to my image's resolution divided by 200. For instance, with a 300-pixels-per-inch image, I'd start with a Radius setting of 1.5 (300 divided by 200). I set the last control—Threshold—to 4, which in effect tells Photoshop to ignore pixels that are less than 4 levels apart on the tonal scale.

If you select Preview mode, Photoshop shows you what your image is going to look like after you click on OK. It's important to view your

image at 100% (Actual Pixels), since that's the most accurate view. The good news is, you don't have to close the dialog box to do so, because you can zoom in and out from within the dialog box.

2. Next, fine-tune the image. If it has a lot of detail (for example, a picture of bare tree limbs against the sky), you need to lower the Radius setting and increase the Amount setting. If it's an image with large objects that have slow color transitions—say, a portrait or a picture of a field of grass—increasing Radius and decreasing Amount will probably improve your image the most. These two settings usually work like a seesaw—as you adjust one up, you should send the other down.

The Unsharp Mask filter accentuates noise—whether it's from JPEG artifacts, your scanner, or a dirty original. You can control this to some degree by increasing the Threshold value. However, if you're using Thresholds higher than 8 or 10, you should probably start looking at other methods of con-



**Sharp Tip** Make a big change, then fine-tune it: change Amount to 200, then adjust up or down until the image looks right.

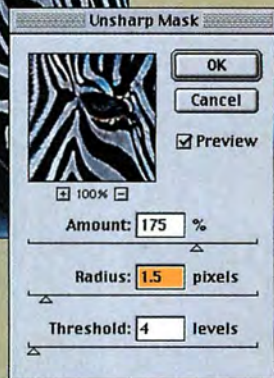

trolling noise (see "Sharpening What You Want").

3. Finally, feel free to throw all these rules out the window and use the settings that work best for your image. Don't be afraid to use a Radius setting as small as 0.3 or so, especially if you're producing images for the Web. Making the image sharp enough on your screen will usually translate to a sharp image on the viewer's screen.

If you will be printing the image, in general the lower the halftone-screen frequency (or the lower the printer resolution), the larger you should make the radius. (If your halo is

much smaller than your halftone dot, it will simply disappear, and so will your sharpening.) Note that there's really no way to get an accurate on-screen preview of how your sharpened image will look in print (the screen image is simply too different from the halftone output).

However, an image that's well sharpened for halftone output often appears decidedly oversharpened on a monitor. If you have doubts, it's better to err on the side of caution—most viewers find a soft image less disturbing than one that's too sharp.

## Behind the Unsharp Mask Filter

The Unsharp Mask filter can't actually make an image sharper—it just makes the image appear sharper by intelligently enhancing the contrast between pixels.

This filter accentuates the transition between light and dark pixels at edges: the dark side becomes darker and the light side becomes lighter, creating a halo effect around an



object's edges. Because Photoshop has to look at every pixel, applying the Unsharp Mask filter can take a long time, especially with large images.



▲ B 1 2 3 4 5 6 7 ▼

UNIFORMS ARE FOR SPORTS

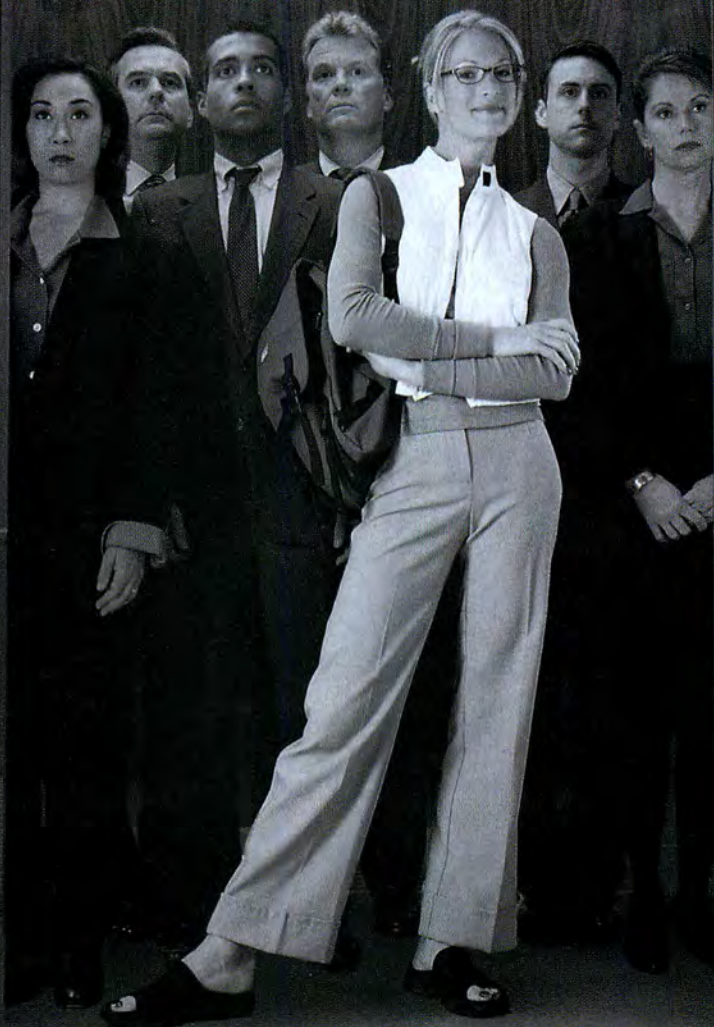

**creativepro**  
● c o m

Asset Management  
Design & Layout  
Fonts & Typography  
Illustration  
Imaging

Motion  
Prepress & Printing  
Stock Photography  
Systems & Hardware  
Web Publishing

where creative business clicks. [www.creativepro.com/mw](http://www.creativepro.com/mw)

Creativepro.com Inc. 1.800.796.9798, 503.274.2020, Fax: 503.274.0530. © 1999 Creativepro.com. All rights reserved. Creativepro.com and the Creativepro.com logo are trademarks of Creativepro.com Inc. CPMWNA011199

Circle 14 on card or go to [www.macworld.com/getinfo](http://www.macworld.com/getinfo)



## Real-World Blends

CREATE MASTERFUL GRADIENTS IN ILLUSTRATOR 8

by Deke McClelland

Those of us who spend too much time staring at cathode-ray tubes can always benefit from an occasional glimpse of real life. So if you can bear to wrench your eyes away from this article, turn and look at the nearest wall—you may have to stand up and peer over your cubicle to find one. Chances are you'll see a single color of paint coating some portion of that wall. And yet you'll notice that the surface comprises a myriad of shades, with the brightest shades near the light source and the darkest ones far away. In the natural world, gradual color transitions are the norm; solid colors are something we never actually witness.

So it's hardly surprising that a solid color applied in Adobe Illustrator or a similar vector program looks altogether synthetic. Images need subtle variations of color to look natural. Illustrator's Gradient palette can spice things up by applying multiple shades and colors, but the resulting transitions are unnaturally regular and don't respond to an object's shape. A better solution is to create custom blends, gradual color transitions between two or more hand-drawn paths. Custom blends give you more control over the shape and speed of your gradients. When you're finished, place the blends inside a mask to adopt an object's shape, and you're on your way to photo-realistic art. (For tips on creating blends, see the sidebar "Perfect Blends.")

While custom blends have been possible for more than a decade—originally popping up in Illustrator's 1988 edition—Illustrator 8 greatly expanded their features. Blends are now live, updating dynamically when you edit the source paths. This ensures that you can edit a blend without having to start from



scratch each time. You can blend three or more paths at a time, creating complex blends that taper gently at the beginning and end. For more-dramatic coloring, you can also blend paths that contain gradient fills, a perfect technique for simulating chrome and other complicated color transitions. Best of all, you can attach the blend to a curve, which means you can precisely mold a color transition to the surface of a rounded object.

For a different effect, Illustrator 8 also provides a Gradient Mesh tool that lets you add points of color inside a shape (see the sidebar "Working with the Gradient Mesh Tool"). Though ultimately less flexible than blending—it can't control the shape of a key color as a blend can, for example—the Gradient Mesh tool does offer the advantages of speed and ease of use.

Be forewarned—creating good, realistic blends is no piece of cake. Even with these added features, blends remain one of the trickiest members of Illustrator 8's arsenal. If you've never experimented with blends before, give yourself some latitude—like sketching with a pencil, getting shading exactly right takes time and patience. But if you're an experienced blender, get ready to take your skills to the next level. Illustrator 8 has the power to create color transitions once all but impossible within a vector-based drawing program. **m**

Contributing Editor DEKE MCCLELLAND is the best-selling author of books on graphics applications, including *Real World Illustrator 8* (Peachpit Press, 1999) and *Photoshop 5 Bible, Gold Edition* (IDG Books Worldwide, 1999).

continues



# Perfect Blends

ILLUSTRATOR 8'S BLEND FEATURE ALLOWS you to create gradients that conform to an object's exact contours. Although the concept is fairly straightforward—you essentially draw two paths marking the beginning and ending of the blend and then tell Illustrator to interpolate them—*perfecting* a blend is anything but simple. Blending is rife with

parameters, so many that it's surprising when something *doesn't* go wrong. Fortunately, a little bit of blending theory goes a long way toward learning how to anticipate, decipher, and remedy problems.

Consider the example of the Ping-Pong paddle to the right. I've used automatic gradients to shade the handle, and custom

blends to add shadows inside and behind the ball. In the following steps, I'll show you how to shade the paddle's red pad. I could apply a linear gradient, but a blend will result in a more naturalistic effect.

**1** To begin, create the first (A) and last (B) paths in the blend and fill them as desired. As a general rule, paths should echo the contours of the shape you are filling. For best results, these two key paths should contain an equal number of points and should not be stroked. To blend them, select both paths and press  $\text{⌘}$ -option-B (or under the Object menu, choose Blends and then Make).

**TIP:** Notice that I've avoided overlapping the ball shadow (outlined in black) and the paddle blend. The effect may be less realistic than you'd like, but mixing blends requires so much effort and attention to minute detail that I avoid it at all costs.

**2** The downside of Illustrator's blends is that you can't control their speed. The distribution of colors between two paths plods along uniformly from beginning to end. If you want to taper the gradient—say, fade it quickly at the outset and then more slowly toward the end—you have to add an intermediary path (C). The easiest way to do this is to clone one of the existing key paths. Because the stacking order of paths affects blending, always clone the path just behind the one you want to add. In this case I've cloned path A. Modify the fill of the new path to create the desired blend.

**TIP:** Illustrator creates an invisible path—called a spine—that runs perpendicular to the blend. (To see it, switch to Artwork mode by pressing  $\text{⌘}$ -Y.) Each point in the spine controls the position of a path; adjusting the points repositions the corresponding paths. By default, the spine's segments are straight, which can make your blend look choppy. To smooth out transitions, use the Convert Point tool to convert the spine's corner points to smooth ones. This often has the added effect of making the blend more closely follow the contour of a path.

**3** If you are still not satisfied with a blend's appearance, adjust the orientation of the paths along the spine. First make sure you've selected the blend; then go to the Blends submenu under the Object menu. Choose Blend Options and select the second orientation button. This spreads the paths along the spine as if they were slats in a fan. Oddly, the fan centers on the spine, so the blend has a tendency to pivot around the spine like a propeller. Taking this into account, I enlarged the paths and moved the spine to the bottom of the paddle.

**4** Now that you've created the blend, you need to apply it to the object: in this case, the paddle's red pad. To do this, select the shape and press  $\text{⌘}$ -X to cut it. Then select the blend and press  $\text{⌘}$ -F to paste the shape in front. While holding down the shift key, select both the shape and the blend and press  $\text{⌘}$ -7 (or under the Object menu, select Masks and then Make) to mask the blend with the shape. Unfortunately, this has the added effect of removing the fill and stroke from the shape. To reinstate these attributes, select just the shape with the Direct Selection tool and reapply the desired settings.





# Working with the Gradient Mesh Tool

ILLUSTRATOR'S GRADIENT MESH TOOL LETS you add points of color to a fill, and then it blends them. While it provides no method for constructing specific shape blends, a gradient mesh comes in handy

for adding indefinite highlights and shadows. For example, in his photo-realistic rendering of the John Deere logo, graphic artist Brad Neal relied on standard blends to shade the deer icon and the wedge-

shaped highlight in the upper-left corner of the name plate. The rest of the name plate requires generalized color transitions, making a gradient mesh the perfect choice.

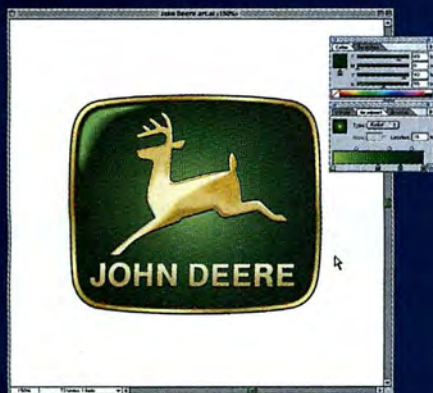

**1** Neal started by selecting the name plate and filling it with a radial gradient. The gradient comprised four progressively darker shades of green, as seen in the Gradient palette on the right.



**2** Next, Neal converted the radial gradient to a mesh by choosing the Expand command from the Object menu. To make sure he converted only the fill colors, he turned off the Stroke check box; then he selected the Gradient Mesh radio button. The result was a target of four concentric circles, each representing a ring of color in the radial gradient.

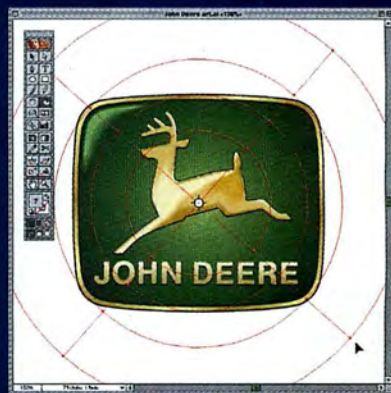

**3** The Expand command placed the mesh target inside a mask, permitting Neal to modify the gradient independent of the name plate. Using the Direct Selection tool, he deselected the name plate and selected the gradient mesh target on its own. He then used the Rotate and Scale tools to transform and position the target to better suit his needs.

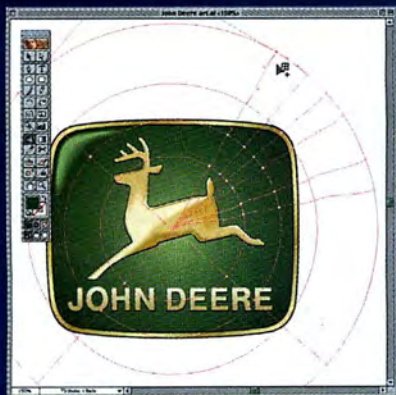

**4** To add more points of color to the gradient, Neal selected the Gradient Mesh tool and clicked a total of five times along the upper-right perimeter of the target. Illustrator added a series of five lines to the target, radiating outward from the target's center. The five lines intersect the four concentric rings, resulting in 20 new points of color.

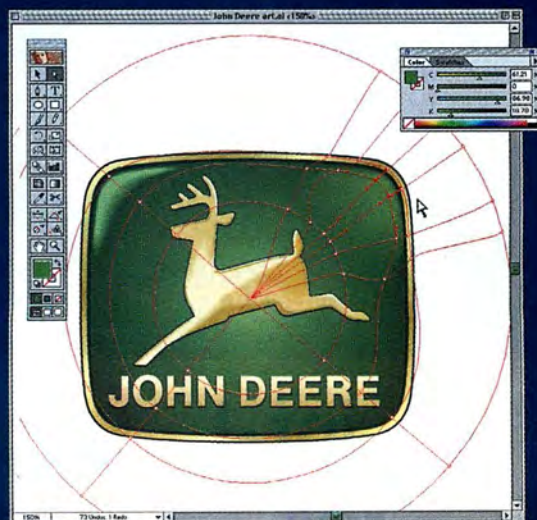

**5** From there, it was just a matter of changing the colors of the points and moving them into position. Using the Direct Selection tool, Neal selected and dragged points within the mesh target. (These points and connecting segments behave just like standard paths—you can drag points and control handles, and you can even select multiple points by shift-clicking on them.) Once he'd selected the points, Neal changed their colors from the Color palette. With very little tweaking, he was able to add a credible highlight to the name plate's upper-right corner.



# AND THE NOMINEES ARE ...

*"Forget the Oscars, here come*

# THE WEBBYS"

*— New York Times*



Honoring the best of the Web. [www.webbyawards.com](http://www.webbyawards.com)  
Webby Award Nominees announced March 1.

Sponsors include:



An IDG Event



## Zap Common Browser Bugs

DON'T LET BROWSER IDIOSYNCRASIES RUIN YOUR WEB-PAGE DESIGNS

by Lisa Schmeiser

The last time I went on a picnic, I meticulously ant-proofed everything. But it didn't matter: those little buggers showed up everywhere. The same thing can happen to flawlessly written HTML code—even if you're sure your code is perfect, a browser can wreak havoc with your carefully created design.

There are all kinds of ways that bugs can creep into your Web pages. The small font that looks so clean on a PC may look tiny on a Mac. The spacer rows you added between a page's sections may disappear in Netscape Navigator. Or the precisely proportioned headlines and sub-headlines on a page (such as `<font size=4>`, `<font size=3>`, or `<font size=2>`) might look different on different machines.

It's easy to assume that the cause lies in your HTML-writing skills—after all, who hasn't made a glaring mistake in their code at least once? But sometimes it's the browser's fault. Browsers process and read HTML differently, and that can affect the way your page renders. In addition, users may have adjusted their browsers' font settings—some people prefer to read everything in 16-point Courier—and that can throw your designs out-of-whack.

Web developers face the challenge of building pages that anyone, using any browser on any platform, can read. So how can you do that without driving *yourself* buggy? It's easy—remember what the biggest rendering bugs are and work around them. This article identifies some of the most common problems and shows how to write HTML around them. (I've included lines of HTML to illustrate my points, but if you want to see the complete code, go to [www.macworld.com/2000/04/create/browserbugs.html](http://www.macworld.com/2000/04/create/browserbugs.html).)

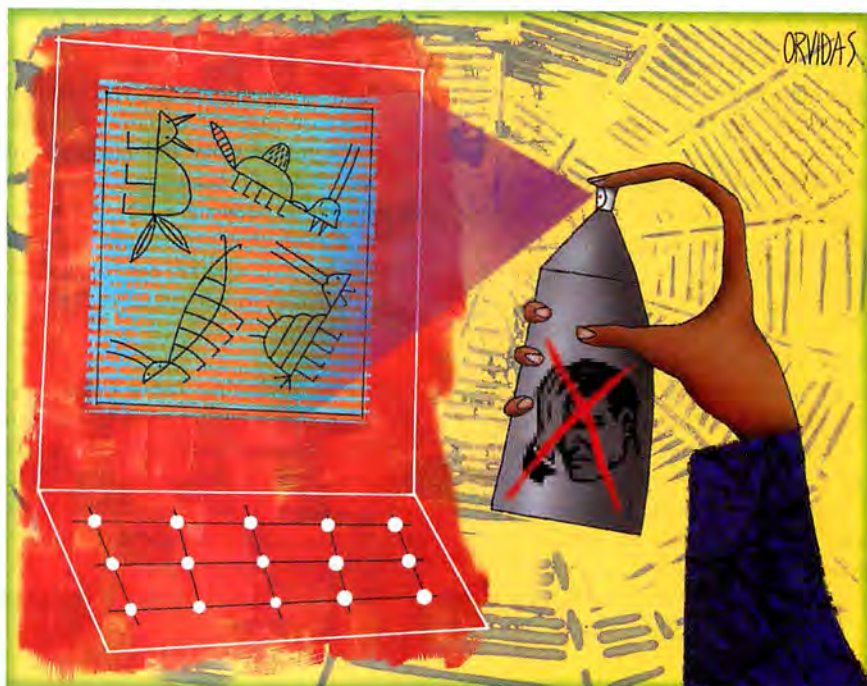

### Problem: Inconsistent Fonts

Users muck around with their browsers' font settings for a couple of reasons: legions of Web developers have fallen in love with small fonts, and Microsoft Internet Explorer has added the Larger and Smaller font buttons to the browser tool bar. As a result, plenty of Web visitors are undoing designers' itty-bitty font specifications by clicking on the Larger button until they can read the text. This can throw a layout horribly out of proportion, with bloated line spaces and badly broken subheadlines.

### Solution: Use Flexible HTML Tags

The only way you can absolutely guarantee consistent text appearance in your visitors' browsers is to turn each page into one big GIF file—highly impractical. A more realistic solution is to prevent font

mishaps by simplifying your HTML. If you want small text, use the `<small>` tag. A browser will then scale the text relative to a user's default font. For instance, if the default font is 12-point, the small font will be 10-point.

If you want to incorporate a variety of font sizes in a page, use the `<big>` and `<small>` tags as HTML headings. These varying sizes scale proportionally to the visitor's default browser settings, guaranteeing preservation of the general proportions of a layout no matter how large or small a visitor's font settings. Tags such as `<font size="+2">` and `<font size="-1">` don't scale nearly so elegantly.

### Problem: Migrating Layout

In theory, the first element of a Web page—whether it's a table, a graphic, or

*continues*



something else—should use the upper-left corner of a browser window as the point of origin. That's true, but it's not exact. Browsers add space that makes your layout migrate several pixels away from the corner (see "Drifting Layout"). If it's important that your layout start in the corner, without any spaces above or to the left, this browser offset could throw your whole design off.

The amount of extra space a browser adds to your layout depends on the user's platform: on the Mac, whether you're viewing a page with Navigator or Internet Explorer, the layout will move 8 pixels down and 8 pixels to the right. PC users have it even worse: the offset in Internet Explorer for the PC is 10 pixels down and 15 to the right.

**Solution: Add Margin Attributes**

Browser offset is one of the easier design problems to work around—just add margin attributes to your `<body>` tag. You will need four of them.

`marginwidth` determines how many pixels of space are between the left edge of a browser window and the items within an HTML document's body.

`marginheight` sets the placement of items relative to the top of the browser.

`leftmargin` tells the browser the pixel width of the left margin (similar to the `marginwidth` attribute).

`topmargin` tells the browser the pixel



**Drifting Layout** To prevent browsers from shifting your layout several pixels down and over (right), add margin attributes (`marginwidth`, `marginheight`, `leftmargin`, `topmargin`) to your HTML code.



width of the top margin (similar to the `marginheight` attribute).

Even though there seems to be duplication in the attribute tags, you need all four because Internet Explorer 3.0 supports the `marginwidth` and `marginheight` tags while the 4.0 browsers support the `leftmargin` and `topmargin` tags. Unfortunately, if your users access your site with Navigator 3.0, you're out of luck—there's no way to get rid of offset with that browser.

**Problem: Shrinking Table Cells**

HTML tables were designed to let Web developers format tabular data neatly; you aren't *really* supposed to use tables to control page layout. But that doesn't mean we can't complain about the misbehavior of our misused tables.

One of the most common complaints

about tables is that table cells don't maintain their sizes. (This tends to affect Navigator viewers more often than their Internet Explorer counterparts.) When you write a table, you should set both the width of the table and the widths of its constituent cells; this helps the table render quickly, because the browser knows how wide every cell must be. Otherwise, it has to read the table contents and try to scale the cells proportionally.

But Navigator may still run into some problems with your tables, sometimes even shrinking cells. When a cell's content isn't as wide as the cell itself, the browser snaps the cell to the width of the content.

**Solution 1: Make Cell Content the Right Size**

One way to make sure a cell doesn't shrink is to fill it with content that will

## Malignant Alignment

To take out unwanted space between cell content, follow these steps (for the complete before-and-after HTML, go to [www.macworld.com/2000/04/create/](http://www.macworld.com/2000/04/create/)):

- 1 Change the table width to reflect the table's contents.
- 2 Move the `valign` attribute to the table row, since it's consistent for each cell, and set images in the top row to align vertically with the bottom of the row:
 

```
<table width="360" cellspacing="0" cellpadding="0" border="0">
<tr valign="bottom"> </tr>
<tr valign="top"> </tr>
</table>
```
- 3 Align the cells by pushing them to the right if they're on the left-hand side, and to the left if they're on the right-hand side.



Before

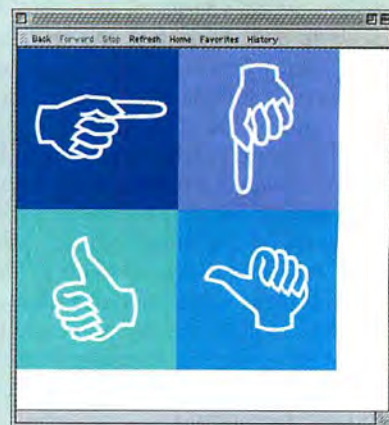

After



# The Flexible Layout

MAKING SURE THAT VISITORS TO YOUR SITE SEE THE exact design you intended can be tricky. Sometimes creating a design that can change depending on who's visiting your site is easier. In the case of tables, one option is to make a row of cells that can shrink.

In this example, I wanted to have a table with white space on the left-hand side, so I formatted the left-hand column like this: `<td width="20">&nbsp;&nbsp;&nbsp;</td>`. By writing the code like this, I built in flexibility: the column will either be 20 pixels wide or shrink to the size of its contents—one nonbreaking space (`&nbsp;`). The size of the nonbreaking space depends on the font-size settings on the user's browser.

Browsers that read and set cell sizes based on their specific width will set the column width to 20 pixels; browsers that render cell sizes based on the width of the cell content alone will shrink the column to the size of the nonbreaking space. Since the purpose of the column is to provide a buffer of white space on the left-hand side of the page, the page renders acceptably on any browser.



**Outsmart the Browser** Even a browser that shrinks the left column in this table won't ruin the layout. To make sure the column doesn't disappear, though, you need to insert a nonbreaking space.

force a cell to maintain its size, as in the sample cells following.

Sample 1: `<td width="20">&nbsp;&nbsp;&nbsp;</td>`

Sample 2: `<td width="400"><img src='banner.gif' width="400"></td>`

The first sample shows how to use nonbreaking spaces (`&nbsp;`), which are handy if you're using a cell for space or for a margin. The second sample contains a graphic that's the same width as the cell.

## Solution 2: Make Your Layout Flexible

The second way to step around the shrinking-cell problem is to modify your layout so that precise cell size doesn't matter. See "The Flexible Layout" for an example of a table that can expand and contract as needed.

## Problem: Misaligned Cell Content

Another common complaint about tables is that the contents of a cell don't align as intended. For instance, you may want the contents of two cells to adjoin, but you end up with white space between cells.

## Solution 1: Don't Settle for Default Table Attributes

Browsers default to the following attributes: `table cellpadding 1 pixel`, `table cellspacing 1 pixel`, `valign=top`, and `align=left`. These defaults can mess up a

table's appearance, so it's up to you to specify the right values for your layout. See "Malignant Alignment" for an example of how to adjust attributes.

## Solution 2: Compact Your Code

After you've tweaked your table attributes, the end result may work beautifully in Internet Explorer but still go awry in Navigator—because Navigator inserts extra white space at line breaks and hard returns.

You can eliminate this white space by compacting your code: eliminating extra line breaks, hard returns, and tabs. Compacting doesn't affect the format of text within `<body>` tags or `<table>` tags—it just cleans up the spaces between individual tags. Here's what compacted code looks like:

```
<!doctype html public "-//w3c//dtd
html 4.0 transitional//en" "http://
www.w3.org/tr/rec-html40/loose.dtd">
<html><head><title>table test #2
</title></head><body bgcolor=
"#FFFFFF" marginheight="0"
marginwidth="0" leftmargin="0"
topmargin="0"><table width="360"
cellspacing="0" cellpadding="0"
border="0"><tr valign="bottom">
<!--put table content here-->
</tr></table></body></html>
```

It's harder for people to read but much better for browsers. Tip: If you're

using Bare Bones Software's BBEdit, you can use the Format Text option (under the Utilities menu) to compact code; otherwise, you'll have to wipe out white space on your own.

## The Secret to Bug-Free Pages

The real secret to writing bug-free pages is simple: avoid building complicated pages. Using HTML as a design language to control the visual attributes of a page is a tricky proposition at best, and the more tricks you use, the more likely you are to encounter a bug.

This isn't meant to discourage you from pushing design limits with HTML. If you're truly committed to executing cutting-edge design online, however, you might want to consider using Macromedia Flash or some other technology that gives you a great deal of control over the visual appearance of your Web pages.

On the other hand, there's a certain Zen appeal in writing simple HTML: you can concentrate on making your pages look attractive and original—and rest assured that they'll look consistent across different browsers. ■

Online Senior Editor LISA SCHMEISER prefers alfresco coding. She's the author of *The Web Design Templates Sourcebook* (New Riders, 1997) and *The Complete Website Upgrade & Maintenance Guide* (New Riders, 1998).



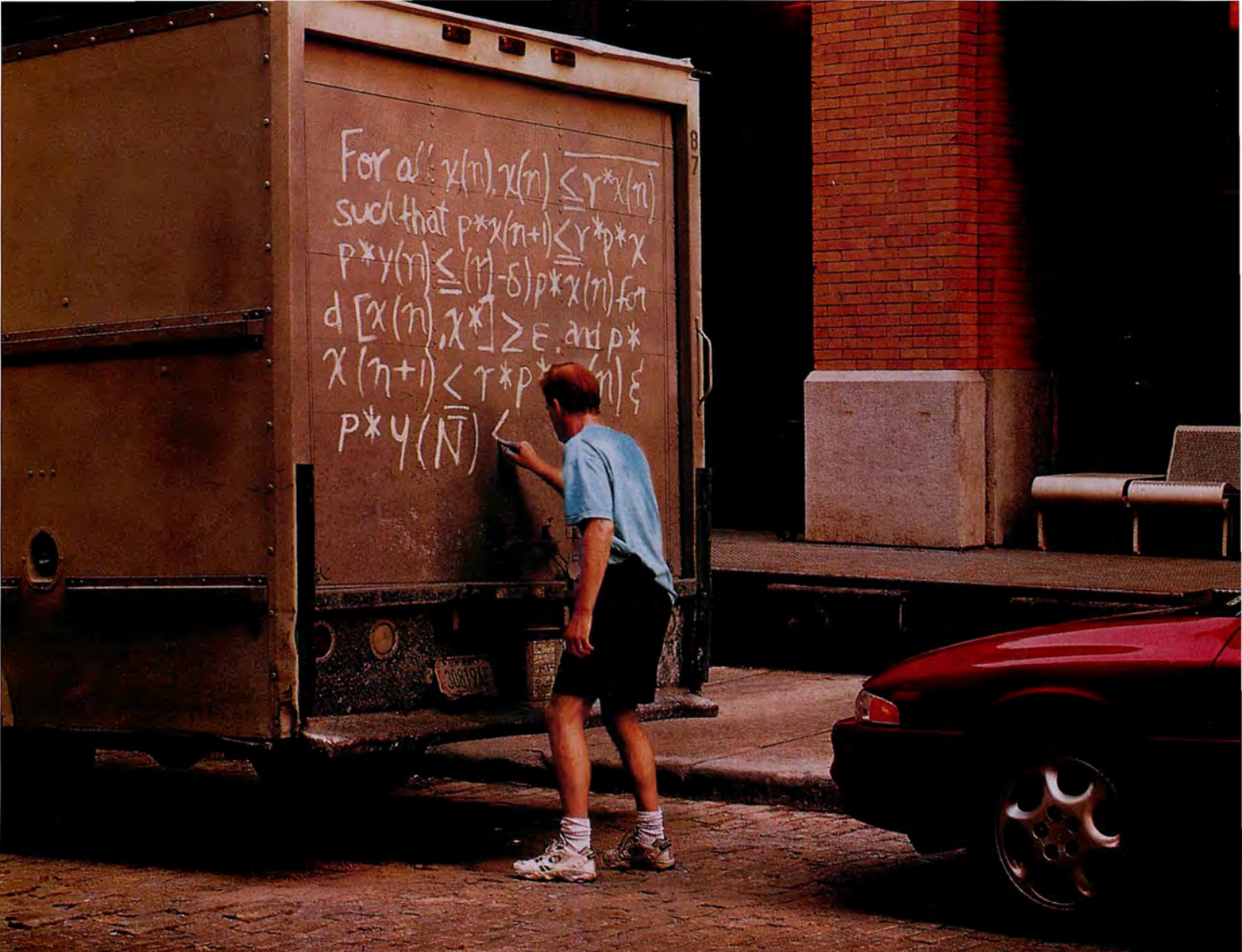

During Mile 3, develops plan to reallocate company's 401(k) holdings 

[Sprint home](#)

[Log on to Office.com](#)

[Post question in financial community center](#)

[Review latest trends in employee benefits](#)

[Use interactive tool to analyze financial impact of new plan](#)

[Schedule meeting with decision team](#)

[Order new desk to put feet up on](#)

Today's businesspeople are always thinking. Always looking for better answers and solutions. Now they can find them at Office.com—the top-rated online business center with expert, in-depth information on nearly 150 industries and professions, unparalleled tools and access to the people and services businesspeople need the most. **The new way to work.™**

**office.com**<sup>sm</sup>  
a service from winstar



# INDEX TO ADVERTISERS

Interact with the companies whose products and services are advertised in **Macworld**

ADVERTISER	INTERACT	PAGE NO.	ADVERTISER	INTERACT	PAGE NO.
Activision	www.activision.com	71	J&R Computer World	800-221-8180	140
Adaptec	www.adaptec.com/mac	37	Kensington	www.kensington.com/imac BC	
AEC Software	www.aecsoft.com	10	La Cie	—	59
Alsoft	800-257-6381	8	Mac Zones	www.maczone.com	111-119
American Power Conversion	888-289-APCC ext. 8823	49	MacMall/Creative Computers	800-222-2808	128-135
APS Technologies	800-285-0638	138,139	Macromedia	800-457-1774	45
Asanté Technologies	www.asante.com	91	MacSoft	www.gtstore.com	68
ATI Technologies, Inc.	www.atitech.com/ad/mac	41	MacWarehouse	800-434-3035	120-127
Canon Computer Systems	www.CCSI.CANON.COM	IFC,1	MegaHaus	800-786-1184	142
Canon Computer Systems	www.CCSI.CANON.COM	2,3	MicroMat	800-829-6227	26
CDW Computer Centers, Inc.	800-509-4239	136,137	Mitsubishi Electronics	800-843-2515	31
Connectix	www.connectix.com	61	Office.com	www.office.com	108
Creativepro.com	www.creativepro.com	100	Orange Micro	714-779-2772	62
Creativepro.com	www.extensis.com/mw	53	OTT-Lite Technology	800-842-8848	60
Crucial Technology	www.crucial.com	14,15	Palm Computing	www.palm.com	9
Dataviz	800-270-0030 ext. 133	47	Par Technologies / iRez	www.irez.com	11
Diehl Graphsoft	www.diehlgraphsoft.com	24	PowerOn	www.poweronsw.com	67
Escent	www.dvdchanger.com	65	ProDirect	800-524-9952	141
Formac	www.formac.com	63	Scitex	800-579-9452	57
GCC Technologies	www.gcctech.com	6,7	Sonnet Technologies	800-786-6260	92
Getty Images	www.gettyone.com	43	TechWorks	800-434-4032	12
Global Village	www.globalvillage.com	39	ViewSonic	800-888-8583	55
Handspring	www.handspring.com	21	VST Technologies, Inc.	www.vsttech.com	13
Hewlett Packard		32,33	Wacom Technology Corp.	800-922-2585	23
Hire Knowledge	www.hireknowledge.com	18	Webbys	www.webbyawards.com	104
Infowave	800-817-9158	80	XANTÉ Corporation	www.xante.com	IBC
Intego, Inc.	www.intego.com	51			



# PRODUCT INDEX

Looking for a specific product? Simply use *Macworld's* product index to find the page or the advertiser of the products which interest you. Then simply log on at [www.macworld.com/getinfo](http://www.macworld.com/getinfo) and receive all the product information you need.

PAGE NO.      ADVERTISER      GET-INFO      PAGE NO.      ADVERTISER      GET-INFO

## HARDWARE

### COMPUTER SYSTEMS

128-135	MacMall / Creative Computers	131
13	VST Technologies, Inc.	73

### HARD DISK STORAGE

138,139	APS Technologies	62
138,139	APS Technologies	62
59	La Cie	—
141	ProDirect	135
12	TechWorks	129

### MISCELLANEOUS

49	American Power Conversion	72
14,15	Crucial Technology	—
65	Escient	—
21	Handspring	—
BC	Kensington	1
60	OTT-Lite Technology	42
9	Palm Computing	—
23	Wacom Technology Corp.	84

### MONITORS/ GRAPHICS BOARDS

37	Adaptec	—
41	ATI Technologies, Inc.	113
63	Formac	—
31	Mitsubishi Electronics America	261
62	Orange Micro	60
92	Sonnet Technologies	132
55	ViewSonic	—

### NETWORKING PRODUCTS

91	Asanté Technologies	130
39	Global Village	106

### PRINTERS

IFC,1	Canon Computer Systems, Inc.	23
6,7	GCC Technologies	43
32,33	Hewlett Packard	11
IBC	XANTÉ Corporation	112

### SCANNERS & DIGITAL CAMERAS

2,3	Canon Computer Systems, Inc.	23
11	Par Technologies / iRez	143
57	Scitex	122

## MAIL ORDER

136,137	CDW Computer Centers, Inc.	2
140	J&R Computer World	56
111-119	Mac Zones	71
120-127	MacWarehouse	18
142	MegaHaus	107
141	ProDirect	135

## SERVICES

### INTERNET PRODUCTS/SERVICES

100	Creativepro.com	14
51	Intego, Inc.	85
18	Hire Knowledge	97
108	Office.com	149
104	Webbys	—

## SOFTWARE

### BUSINESS/PRODUCTIVITY

10	AEC Software	83
47	Dataviz	142
24	Diehl Graphsoft	46

### CLIP ART & FONTS

43	Getty Images	—
----	--------------	---

### ENTERTAINMENT

71	Activision	24
68	MacSoft	29

### GRAPHICS/DTP

53	Creativepro.com	14
45	Macromedia	36

### UTILITIES

8	Alsoft	140
61	Connectix	105
80	Infowave	32
26	MicroMat	67
67	PowerOn	118



**\$ Up To 150 Instant Rebate!**

on select computers with purchase of hand-held PDA.

Limited time offer.  
Offer subject to change.



Call now for complete details!

**Mac Zones is Your Palm Headquarters!**

Big value in a small package!  
Palm IIIx™ Connected Organizer

**\$70 PRICE DROP!**

ONLY **\$229.98** #100086



Ultra-thin and ultra-light executive organizer!  
Palm V™ Connected Organizer

**\$40 PRICE DROP!**

ONLY **\$329.98** #100085



Now with 4X the memory and a faster CPU than the Palm V!  
Palm Vx™ Connected Organizer

**\$30 PRICE DROP!**

ONLY **\$399.98** #112515



Keep your Mac & Palm in sync!



**FREE\*\***  
MacTicker with your purchase of Mac OS 9!

\*After \$20 Apple rebate for 8.5/8.6 owners.  
\*\*Shipping and handling fees apply. While supplies last!

**NEW!**  
Tap into the Internet!  
**Palm VII™**



ONLY **\$449.98** #112690

Replace your bulky paper planner!

**\$30 PRICE DROP!**

Palm IIIe™ Connected Organizer

ONLY **\$149.98** #114314



## Palm Accessories

### Palm III Accessories

#100097	Palm Dual Action Stylus	\$29.98
#60374	Palm Slim Leather Case	\$24.99
#653309	Palm III Leather Case	\$12.99
#649234	Palm Glove Neoprene Case - Black	\$29.98
#649235	Palm Glove Neoprene Case - Olive	\$29.98
#649236	Palm Glove Neoprene Case - Royal Blue	\$29.98
#649431	Palm Connect USB Kit	\$39.99
#60372	Palm III Stylus - 3-Pack	\$8.99
#85646	HotSync Cable	\$18.99
#519419	Palm Leather Belt Clip Case	\$19.99
#60370	Palm III Cradle for Windows	\$28.99
#100098	MacPac	\$14.99
#653309	Palm Color Shades	\$12.99

### Palm V Accessories

#100088	Palm V HotSync Cradle	\$49.99
#100087	Palm V Modem	\$169.99
#100089	Palm V Slim Leather Case	\$24.99
#100090	Palm V Deluxe Leather Case	\$49.99
#100095	Palm V Stylus - 3-Pack	\$9.99
#100091	Palm V Leather Belt Clip Case	\$24.99
#100093	Palm V Hard Case	\$39.99
#100094	Palm V Travel Kit	\$49.99

### Palm Software

#55779	SmartCode Software HandWeb	\$9.99
#55781	SmartCode Software HandFax	\$9.99
#109356	SmartCode Software HandMail	\$19.99
#109357	SmartCode Software Bundle HandFax/HandWeb/HandMail	\$19.98
#655090	Area Code Fix	\$39.99

Corporate bids welcome!  
Fax to 1-800-684-8080

A NASDAQ COMPANY Ticker Symbol: MZON

Source Code  
**MW040**

Order by Phone  
**1.800.436.0606**

Order Online Today  
**Zones.com™**



Save Over **\$719!** the next generation of **The Mac Zone**

**Adobe Publishing Collection**

**ONLY \$948.97**  
#108214

Includes

- Photoshop
- Illustrator
- PageMaker Plus
- Acrobat

**G4 special plug-in makes Photoshop run faster!**

**Save \$70!**

**UPGRADE \$109.97**  
#83084

\*After \$70 mfr. mail-in rebate for owners of Photoshop 5.0 & Image Ready 1.0. Low Zone price: \$179.97

**NEW!**

**ONLY \$99.98**  
#112340

**CANVAS 7 Pro Upgrade**

**ONLY \$298.98**  
#104526

**Over 75 new features!**

**QuarkXPress 4.0 Comp. Upgrade**  
#110995 QuarkXPress 4.0 & CorelDRAW 8 Bndl...\$799.98

**"This is the best font-management program on the market."** Publish 8/99

**ONLY \$39.99**  
#113038

**Font Reserve 2.5 Upgrade**

**Compress media for DVD, CD or the Web!**

**ONLY \$159.99**  
#55918

**Media Cleaner Pro 4.0 Upgrade**



**NEW & Improved!**  
"Sawtooth" logic board in ALL models and up to 40% better video/3D performance!

**As Low As \$1594.98**

**Apple Studio 17" Display**  
(16.0" viewable) **\$494.98**  
#109996

#109995 Apple Studio 21" ..\$1494.98

**Own a Power Mac G4 and 17" Studio Display**  
**Starting at only \$48 MO**  
with the Apple Loan Program!  
Call to apply today!

## Pick the Power Mac G4 that's right for you!

Processor	Hard Drive	RAM Std/Max	Backside Cache	Optical Drive	Modem	Zip Drive	Item #	ONLY	Lease*
G4/350MHz	10.0GB Ultra ATA-66	64MB/1.5GB	1.0MB at 175MHz	DVD-ROM (read only)	56K Internal	Yes	#114855	\$1594.98	\$56
G4/400MHz	20.0GB Ultra ATA-66	128MB/1.5GB	1.0MB at 200MHz	DVD-ROM (read only)	56K Internal	Yes	#114837	\$2494.98	\$88
G4/450MHz	27.0GB Ultra ATA-66	256MB/1.5GB	1.0MB at 225MHz	DVD-RAM (read/write)	-	Yes	#112669	\$3494.98	\$123

\*Business Lease: 36-month, fair-market value lease based on approved credit. Other leasing options available. Leases require a minimum order of \$1000. Call 1-800-611-9751 for details.

**For Better Performance...Upgrade your Power Mac's Memory!**

**Power Mac G4 Memory**

**64MB Upgrade** #521391 **\$79.99\***  
**128MB Upgrade** #521392 **\$169.99\***  
\*After Rebate. Call for latest pricing.

**\$200 OFF ANY purchase at Zones**  
when you open an account with **E-TRADE™**  
Go to [www.zones.com/etrade](http://www.zones.com/etrade) for details

**AppleCare 3 Year Protection Plan**

**5 Reasons to Protect Your Power Mac G4**

- 1 Upgrade from 90-day phone support to 3 Years
- 2 TechTool Deluxe diagnostic software included to fix most problems - \$69 Value
- 3 Exclusive access to AppleCare Web support site
- 4 A total of 3 years of Apple-certified service, both parts and labor
- 5 VALUE... Purchase a G4 and Apple Display on the same invoice and the display is covered for FREE!

**ONLY \$248.96**  
#112894

**Go Wireless!**

**AirPort Base Station**  
**ONLY \$294.98**  
#110920

**AirPort Card**  
**ONLY \$99.98**  
#110919

- Features 56K modem port and 10Base-T Ethernet port
- Supports up to 10 AirPort connections
- Easy to set up
- Wireless connections up to 150 feet
- 11 Mbps data rate

**High-speed, versatile workgroup printing!**

**HP LaserJet 4050N**  
**ONLY \$1379.97**  
#617964

**Fast, high-quality printing!**

**NEW!**

**HP 970Cse Printer**  
**ONLY \$399.99**  
#110974

**EPSON**

**Print it. Scan it. Copy it. Create it.**

**Stylus Scan 2000 USB All-in-One**  
**ONLY \$349.99**  
#111467

**EPL-5700i USB Laser Printer**  
**ONLY \$349.99**  
#111461

\*After \$50 mfr. mail-in rebate. Offer good through 3/31/00.

**we're open 24/7 hours a day 7 days a week**

**NO SURCHARGE ON CREDIT CARDS**

MasterCard VISA

Credit cards are not charged until the order is shipped. Most products ship the same day (barring system failure, etc.). Shipping options include Ground, 2nd Day and Overnight delivery. Freight is based on average product weight. Handling extra. Insurance available. Special orders may require special shipping and handling charges. Call for international shipping rates. Prices and product availability subject to change without notice. Specials and promotions may be limited to stock on hand. Not responsible for typographical errors. All products sold by Multiple Zones International (MZI) are third party products and are subject to the warranties & representations of the applicable manufacturers, including but not limited to Y2K compliance. Accordingly, MZI makes no representation or warranty with respect to Y2K compliance of product sold. ©2000 Multiple Zones International Inc. All rights reserved. Unauthorized duplication is a violation of applicable laws. Apple, the Apple logo, Macintosh and PowerBook are registered trademarks of the Apple Computer, Inc.



# Power & Elegance!

**EXCLUSIVE!**



Up To **\$150**  
**Instant Rebate!**

on select computers with purchase of hand-held PDA.

Limited time offer. Offer subject to change.

Call now for complete details!

## Apple® Power Mac™ G4

### Performance

- Up to 450MHz PowerPC G4 processor with Velocity Engine
- Backside level-2 cache for blazing speed
- 100MHz system bus supports up to 800 MBps data throughput
- Up to 27GB superfast Ultra ATA/66 hard drive

### Expansion

- Up to 1.5GB of high-performance PC100 SDRAM
- Support for up to 100GB hard drive storage
- Three 64-bit 33MHz PCI slots
- Optional DVD-RAM drive reads/writes to DVD-RAM discs with a capacity of up to 5.2GB

### Connectivity

- 10/100Base-T Ethernet connector
- Three 400 Mbps FireWire ports (one internal)
- Two USB ports (12 Mbps each)
- Wireless networking with optional AirPort Card and Base Station

### Style

- Unique swing-open side door for easy upgrade access
- Built-in antenna and optional wireless networking
- Convenient low-power sleep/awake feature (select models)
- Highly polished industrial design

### Multimedia

- ATI RAGE 128 graphics accelerator, 16MB SDRAM graphics memory
- USB and FireWire ports support options such as graphics tablets, cameras, CD-RW drives and DVD jukeboxes
- Optional 100MB Zip drive for removable storage
- Optional DVD-ROM drive plays DVD discs, CD-ROMs and audio CDs

## Turn the ultimate personal computer into YOUR ultimate machine!

Already a stunning 100% to 200% faster than Pentium III based PCs\*, the Power Mac G4 lets you add faster hard drives and controllers, memory, video accelerators and more to suit your need for speed. Just flip the easy open latch, and you have ready access to customize the Power Mac G4 to your heart's content. Order today and put a supercomputer on your desk tomorrow!

\*In CPU and Photoshop tests.

**Brand New Graphite!**



Apple Studio 15" Flat Panel Display

ONLY **\$1294.99**  
#114856

**G4 IS 200% FASTER THAN THE PENTIUM PROCESSOR! TESTS PROVE IT!**

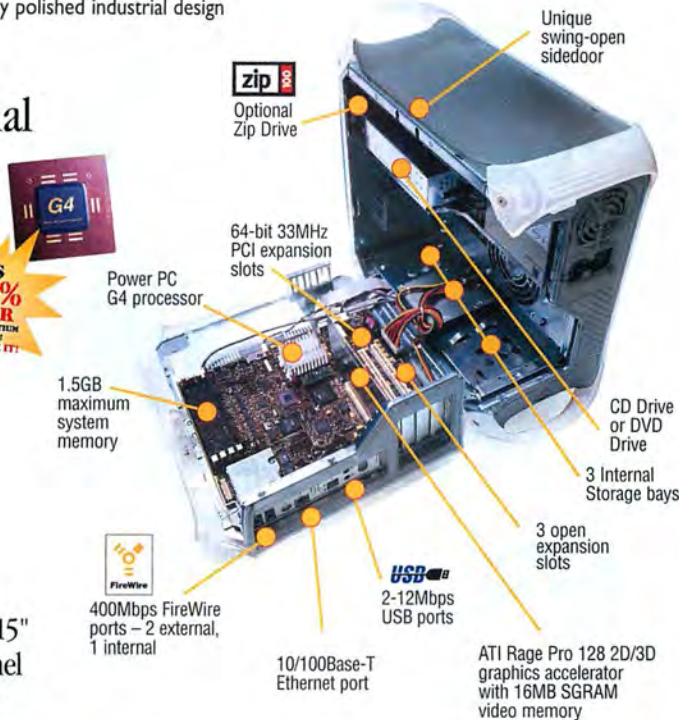

Fuji 5-Pack Zip Disks With **FREE Case!**



ONLY **\$39.99\***  
#88195

\*After \$10 mfr. mail-in rebate. Low Zone price: \$49.98

**Ultra-convenient storage!**



ONLY **\$179.99**  
#650368

**Records all popular CD formats!**



ONLY **\$429.99**  
#621732

**Get fast access to 20.4GB of information!**



ONLY **\$469.99**  
#109210

**FREE FaxSTF Software!**  
While supplies last.

**BLOW OUT PRICE!**  
**\$29.99**  
#102936

Apple Int. 56K V.90 Faxmodem for G3



\*After \$40 mfr. mail-in rebate for upgraders. Low Zone price: \$59.98.



Corporate bids welcome!  
Fax to 1-800-684-8080

A NASDAQ® COMPANY Ticker Symbol: MZON

Source Code  
**MW040**

Order by Phone  
**1.800.436.0606**

Order Online Today  
**Zones.com™**



## Best Sellers!



**NEW!**

**IBM ViaVoice**  
"BEST OF SHOW"  
Macworld Expo  
San Francisco 2000

#664668 **\$74.99**



**Mac Must Have!**

**Office 98**  
Upgrade  
Mac Edition

#55870 **\$249.97**

#105073 MS Office 98 for Mac... \$419.97



**SAVE \$20!**

**NEW Version**  
for Mac!

#653343 **\$39.95\***

\*After \$20 mfr. upgrade mail-in rebate. Low Zone price \$59.95



**USB Compatible**

**Virtual PC**  
3.0  
with Win 98

#654332 **\$169.98**



**Upgrade Now!**

**Acrobat**  
4.0 Upgrade

#83063 **\$89.98**

#93952 Acrobat 4.0 - Full Version... \$219.98



**SAVE \$50!**

**Norton**  
Utilities  
5.0

#652996 **\$44.98\***

\*After \$50 mfr. mail-in rebate for previous Norton owners. Low Zone price \$94.99.

## New at Zones!

**Yellow Dog LINUX**  
for the PowerPC  
Call for details.

**ONLY \$59.99**  
#111130

## FREE Upgrade!

to Apple G3 & G4  
**SCSI Card**  
Fulfilled  
by Microtek



Microtek  
ScanMaker X6-EL

**ONLY \$149.99**  
#18400

## BLOWOUT!

SAVE \$300\*

**Matches Your G3!**

Apple Studio 15" Flat Panel  
\*While supplies last!

**ONLY \$999.99**  
#102931



**Reliability you can trust for your data storage!**

**ONLY \$39.99**  
#115125



FUJI CD-R 25 pack. Platinum with cases.

**Get high-performance & Sony quality!**

**ONLY \$289.98**  
#609482

**USB**

SONY Spressa USB Ext. 4X/2X/6X\* CD-RW  
\*maximum variable speeds

**Crisp, clear monitor for your home or office!**

**17"**

Sony 17" FD A200 Display

**ONLY \$397.99**  
#657525



**ONLY \$99.99**  
#99498

**Adds an external SCSI port to your new Power Mac**  
Adaptec Internal SCSI Card



## Our Best Selling Mac Modem!



Global Village  
Teleport 56K V.90 Fax/Modem

**ONLY \$107.99**  
#60339

**Capture great home videos!**



Canon ULTRA  
Mini DV Camcorder

**ONLY \$999.99**  
#111852

**ONLY \$49.99\***  
#108005



Global Village  
USB Mac Modem  
\*After \$40 mfr. mail-in rebate. Low Zone price \$89.99

**Includes GlobalFax software!**



**Easy-to-use storage!**  
Omega Zip® 100 Portable USB Drive

**ONLY \$129.98**  
#95251



**New advanced photo features - 2.11 megapixels!**  
Nikon CoolPix 950

**ONLY \$789.99**  
#608570



**Zoom in on great pictures!**  
2x Digital Zoom Olympus C-2020 Zoom Digital Camera. Includes remote control.

**ONLY \$799.99**  
#667939

**EPSON**

**SAVE \$50!**

**Rich, detailed color printing!**

Stylus 740 Color Inkjet Printer  
\*After \$50 mfr. mail-in rebate. Rebate expires 3/31/00

**ONLY \$149.99\***  
#31720

**High performance and brilliant output!**

**SAVE \$50!**

Stylus 900G  
\*After \$50 mfr. mail-in rebate. Rebate expires 5/1/00

**ONLY \$329.99\***  
#110986

**Photo-quality printing for graphics pros!**

Stylus Pro 5000

**ONLY \$2995.99**  
#110991



**hp invent**

**NEW!**

**Great speed at budget savings!**

HP DeskJet 832  
\*After \$50 mfr. mail-in rebate. Rebate expires 5/1/00

**ONLY \$179.98**  
#110973



**ONLY \$759.97**  
#102384

**1200x1200 dpi - 10ppm!**  
HP 2100M Printer



**ONLY \$1379.97**  
#617964

**High-performance, versatile network printing!**  
Color LaserJet 4500N Printer



**we're open 24 hours a day 7 days a week**



Credit cards are not charged until the order is shipped. Most products ship the same day (barring system failure, etc.). Shipping options include Ground, 2nd Day and Overnight delivery. Freight is based on average product weight. Handling extra. Insurance available. Special orders may require special shipping and handling charges. Call for international shipping rates. Prices and product availability subject to change without notice. Specials and promotions may be limited to stock on hand. Not responsible for typographical errors. All products sold by Multiple Zones International (MZI) are third party products and are subject to the warranties & representations of the applicable manufacturers, including but not limited to Y2K compliance. Accordingly, MZI makes no representation or warranty with respect to Y2K compliance of product sold. ©2000 Multiple Zones International Inc. All rights reserved. Unauthorized duplication is a violation of applicable laws. Apple®, the Apple logo, Macintosh® and PowerBook® are registered trademarks of the Apple Computer, Inc.



# At Zones.com!



## Apple® iBook™

Authorized Catalog Reseller

**FREE!**  
30 Day  
Earthlink  
Internet  
Access\*  
\$30 value!

ONLY  
**\$1594.98**

**300MHz!**



Own a  
New iBook  
Starting at only  
**\$35 MO**  
with the  
Apple Loan Program!  
Call to apply today!

### Performance

- 300MHz PowerPC G3 processor; 512K backside cache
- 32MB RAM; up to 160MB
- 3.2GB hard drive
- Lithium-ion battery provides up to six hours of operation

### Style

- Crowd-stopping design
- Cool rubber surfaces for easy handling
- Revolutionary closing mechanism with no breakable latches
- Integrated handle makes carrying a snap

### Multimedia

- 12.1" active matrix display
- 4MB video memory and millions of colors
- Built-in ATI Rage Mobility graphics controller
- 24X max. variable speed CD-ROM

### Connectivity

- (1) 12 Mbps USB port
- 10/100T Ethernet and built-in 56K modem
- Optional AirPort card for wireless connection (AirPort Base Station required)

#110915 Apple iBook - Tangerine .....	\$1594.98
#110916 Apple iBook - Blueberry .....	\$1594.98

\*FREE internet access with iBook purchase, subject to terms and conditions of Earthlink. Offer subject to change restrictions may apply.

**EXCLUSIVE!**



Up To **\$150**  
**Instant Rebate!**

Call now for complete details!

on select computers with purchase of hand-held PDA.  
Limited time offer. Offer subject to change.

### Go Unplugged!



#### AirPort Base Station

- Surf the Net or network wirelessly\*
- Up to 150' range lets you and the iBook roam around the home or classroom

#110919 AirPort Card . . . . . \$99.98



Be free of cables with an AirPort Card in your Power Mac and a Base Station.\*

Connect up to 10 AirPort-enabled Macs instantly!\*

Enjoy wireless networking at up to 11 Mbps.\*



\*Requires the AirPort Card, Base Station and a computer that is AirPort Card ready.

**ONLY \$59.99**  
#503773

**Perfect for the iBook or 14" screen notebooks!**  
Targus LapPac 5 carrying case

**3X optical/2X digital zoom!**  
Kodak DC40i Digital Zoom Camera

**ONLY \$599.99**  
#114413

**4X more power than AAs!**  
Digipower External Battery for Digital Cameras

**ONLY \$39.99**  
#07487

**Unparalleled artistic control!**

**ONLY \$99.99**  
#656993

**WACOM**  
Graphire 4x5" USB Tablet with Pen and Cordless Mouse

**ONLY \$39.99**  
#109827

**Take your camera everywhere!**  
Lowepro Digital Camcorder Case

**Make movie magic!**  
Interview Video Capture

**PRICE DROP!**

**ONLY \$79.99**  
#109654

**XLR**

**Save money on batteries!**

**ONLY \$29.99**  
#109953

**DigiPower**  
Rechargeable NMI Batteries

**The easy way to share photos and videos!**

**ONLY \$129.99**  
#113802

**Kritter USB Camera**  
your choice of flavors

**ONLY \$79.99**  
#111113

**USB to IR remote control for DVD, CD, QuickTime or MP3 Player**  
Keyspan Media Remote

**ONLY \$49.99**  
#637018

**Think Music. Think Mac. Think MP3!**  
SoundJam.MP

**Play music over the Web!**

Corporate bids welcome!  
Fax to 1-800-684-8080

Source Code  
**MW040**

Order by Phone  
**1.800.436.0606**

Order Online Today  
**Zones.com™**

A NASDAQ COMPANY Ticker Symbol: MZON



### 5 Easy Steps to Directing your Movies with iMovie!

Included with iMac DV/SE models only.



**FREE** With iMac models!  
Apple® iMovie™

- COLLECT MEDIA**  
iMovie operates your DV camera.
- EDIT VIDEO CLIPS**  
Arrange scenes any way you like.
- ADD AUDIO AND TEXT**  
Liven up your video with music or narration, plus text.
- EXPORT** Send your video to VHS tape or turn it into a QuickTime file then make a CD, e-mail the file or post it on a Web site.
- AMAZE FRIENDS & FAMILY!**

Complete your digital studio and save!

**SONY**

DCR-TRV3310 Digital 8 Camcorder



**ONLY \$999.99**  
#111858

\*Product shown is representational only.

#111844 DCR-TRV510 Digital 8 Camcorder . \$1299.99



**NEW FOR MAC!**

**ONLY \$74.99**  
#664668

- Intuitive and simple-to-use interface
- Speak naturally – no need for you to pause between words
- Make everyday computer tasks a snap
- Create e-mail, edit documents and more
- Integrates with Apple's text-to-speech function
- As easy to use as reading out loud



**Mac OS 9**

**FREE\*\*** with your purchase of Mac OS 9!

Your choice of:  
MacTicker #110198  
Spring Cleaning #114859  
Great Photo #114866  
Mac OS 9 T-shirt #114860

**ONLY \$69.99**  
#111431

\*After \$20 Apple rebate for Mac OS 8.5 or 8.6 owners.  
\*\*Shipping and handling fees apply. White supplies last.

**FREE!** Bug's Life DVD movie with every iMac DV! \$30 VALUE! (Title subject to change)

## iMacs™

Starting At **\$994.97**

### Digital Video for Everyone!

**ONLY \$1294.98 EACH**

**Special Edition \$1494.98**  
Graphite #112624

**Built-in Spectacular Stereophonic SOUND**  
Harman Kardon Odyssey Sound System  
Included with each of Apple's newest iMacs!

Authorized Catalog Reseller

### Pick the iMac that's right for you!

Model	Processor	HD	RAM	Optical	USB	Firewire	AirPort Ready	iMovie	Item #	ONLY	Lease*
Blueberry/350	350MHz	6.0GB	64MB	CD	2 ports	No	Yes	No	#112623	\$994.97	
Strawberry DV	400MHz	10.0GB	64MB	DVD	2 ports	2 ports	Yes	Yes	#112620	\$1294.98	\$46
Lime DV	400MHz	10.0GB	64MB	DVD	2 ports	2 ports	Yes	Yes	#112621	\$1294.98	\$46
Tangerine DV	400MHz	10.0GB	64MB	DVD	2 ports	2 ports	Yes	Yes	#112618	\$1294.98	\$46
Grape DV	400MHz	10.0GB	64MB	DVD	2 ports	2 ports	Yes	Yes	#112619	\$1294.98	\$46
Blueberry DV	400MHz	10.0GB	64MB	DVD	2 ports	2 ports	Yes	Yes	#112622	\$1294.98	\$46
Special Edition DV	400MHz	13.0GB	128MB	DVD	2 ports	2 ports	Yes	Yes	#112624	\$1494.98	\$53

\*Business Lease: 36-month, fair-market value lease based on approved credit. Other leasing options available. Leases require a minimum order of \$1000. Call 1-800-611-9751 for details.

Share a single Internet connection in your home or business without cables or additional phone lines\*!

**ONLY \$294.98**  
#110920

#110919 AirPort Card...\$99.98 \*Requires the AirPort Card

### AirPort Base Station

### Upgrade Your iMac or iBook!

For iMac 233/266/333MHz		ONLY
#674336	32MB Upgrade	\$39.99*
#674372	64MB Upgrade	\$64.99**
#674325	128MB Upgrade	\$169.99!
For iMac 350/400MHz		ONLY
#674339	64MB Upgrade	\$64.99**
#674325	128MB Upgrade	\$169.99!
For iBook		ONLY
#674335	32MB Upgrade	\$39.99*
#674372	64MB Upgrade	\$64.99**
#674325	128MB Upgrade	\$169.99!

\*After \$15 mfr. mail-in rebate. Low Zone price: \$54.99. \*\*After \$20 mfr. mail-in rebate. Low Zone price: \$84.99. †After \$30 mail-in rebate. Low Zone price: \$199.99. Limited time offer.

### AppleCare Protection Plan

**5** Reasons to Protect Your iMac

- 1 Upgrade from 90-day phone support to 3 Years
- 2 TechTool Deluxe diagnostic software included to fix most problems – '69 Value
- 3 Exclusive access to AppleCare Web support site
- 4 A total of 3 years of Apple-certified service, both parts and labor
- 5 VALUE... 3 years of protection for only **\$148.96** #112693

Credit cards are not charged until the order is shipped. Most products ship the same day (barring system failure, etc.). Shipping options include Ground, 2nd Day and Overnight delivery. Freight is based on average product weight. Handling extra. Insurance available. Special orders may require special shipping and handling charges. Call for international shipping rates. Prices and product availability subject to change without notice. Specials and promotions may be limited to stock on hand. Not responsible for typographical errors. All products sold by Multiple Zones International (MZI) are third party products and are subject to the warranties & representations of the applicable manufacturers, including but not limited to Y2K compliance. Accordingly, MZI makes no representation or warranty with respect to Y2K compliance of product sold. ©2000 Multiple Zones International Inc. All rights reserved. Unauthorized duplication is a violation of applicable laws. Apple®, the Apple logo, Macintosh® and PowerBook® are registered trademarks of the Apple Computer, Inc.

**we're open 24/7**  
hours a day  
days a week





# Are Always Here!

Super Values on Everything You Want and Need!

## \$200 OFF

ANY purchase at Zones  
when you open an account with

**E-TRADE™**

Go to [www.zones.com/etrade](http://www.zones.com/etrade) for details

### EXCLUSIVE!



Up To **\$150**  
**Instant Rebate!**

on select computers with  
purchase of hand-held PDA.

Limited time offer.  
Offer subject to change.

Call now for  
complete details!

### Best Sellers!



**SAVE \$20!**

**NEW Version for Mac!**  
#653343 **\$39.95\***

\*After \$20 mfr. upgrade mail-in rebate.  
Low Zone price \$59.95



**SAVE \$30!**

**Special Edition for the iMac & iBook**

#648707 **\$77.97\***

\*After \$30 mfr. mail-in rebate.  
Low Zone price: \$107.97. Limited time offer.



**New Version!**

**Virtual PC 3.0**  
with Win 98

#654332 **\$169.98**

### Top Games!



#### Games

	Item #	ONLY
Madden NFL 2000	#111576	\$44.98
Rainbow Six	#111566	\$44.99
Baldur's Gate	#625850	\$44.99
Age of Empires	#111565	\$44.99
Tomb Raider III	#111573	\$44.98
The Big Kahuna	#108263	\$48.99
SimCity 3000	#111560	\$44.99
Myth: The Total Codex V1.0	#662611	\$19.99
Descent 3	#625849	\$39.98
Total Annihilation Gold Fly!	#111567	\$32.99
Railroad Tycoon II	#1112108	\$44.99
ChessMaster 6000	#111561	\$34.99
Quake III	#653212	\$32.98
Unreal Tournament	#112118	\$49.99
Budgom 3D for the Family	#111907	\$44.99
Sid Meiers Alpha Centauri	#114493	\$29.98
	#111574	\$44.98

#### MacInTax Deluxe

Includes  
**FREE\***  
MacInTax State  
\$27 Value!

\*After mfr. mail-in rebate.



### FREE\*

**AntiVirus 6.0 Upgrade**  
with MacInTax purchase!

Ask for item #652997  
\*After mfr. mail-in rebates.  
Low Zone price: \$59.98.



#### Great iMac add-ons!



**ONLY \$179.99**  
#650368  
**250MB of removable storage!**  
Iomega USB Zip 250 Drive



**ONLY \$39.99**  
#111199  
**Give your eyes a rest!**  
3M iMac Anti-glare Filter



**ONLY \$149.99**  
#109035  
**Use floppy disks and add 120MB storage!**  
Imation USB SuperDisk Drive 2X



**ONLY \$99.99**  
#114555  
**New iCandy colors!**  
Graphire 4x5" USB Tablet with Pen and Cordless Mouse

#### Input / Printers

**The trackball iMac users have been waiting for!**

Kensington Orbit Trackball - iMac Blueberry Blue

**ONLY \$49.99**  
#602571

**Full-size, soft-touch for comfort and control!**



MacALLY iKey USB Extended Keyboard

**Vibrant 42-bit color with the push of a button!**

Umax MX3 Scanner

**ONLY \$149.99**  
#111169

\*After \$30 mfr. mail-in rebate



**#1 selling iMac printer!**

Epson Stylus 740i Color Inkjet Printer

**ONLY \$179.99**  
#107815

\*After \$50 mfr. mail-in rebate.  
Low Zone price: \$229.99.  
Offer good through 3/31/00.

#### Connectivity

**Connect your existing printer to your iMac!**



Keypan USB Twin Serial Adapter

**ONLY \$79.99**  
#621851



**Trouble-free USB connections!**  
Belkin 4-port Stackable USB Hub with Click-on Flavors

**ONLY \$59.99**  
#111991

Corporate bids welcome!  
Fax to 1-800-684-8080

A NASDAQ COMPANY Ticker Symbol: MZON

Source Code  
**MW040**

Order by Phone  
**1.800.436.0606**

Order Online Today  
**Zones.com™**



### Mac Zone Exclusive!



ONLY \$69.98\*  
#111431

**YOUR CHOICE FREE** with your purchase of Mac OS 9! \*\*



\$30 Value!

Ask for item #110198



\$50 Value!

Ask for item #114859



\$10 Value!

Ask for item #114860



\$40 Value!

Ask for item #114865

\*After \$20 Apple rebate for 8.5/8.6 owners.  
\*\*Shipping and handling fees apply. While supplies last!

## PLUS Mac OS 9 includes these incredible values!

**FREE** Apple Remote Access Client AND Server  
**\$179 Value!**

**FREE** Apple Language Kits (7 Total!)  
**\$599 Value!**

**FREE** Apple Network Assistant 4.0 Client\*  
**\$399 Value!**

**FREE** Palm Desktop & Hot Sync for Palm Users  
**\$20 Value!**

\*Client ships FREE on OS 9 CD. Administrator CD ships FREE with all versions of AppleShare IP 6.3. FREE download update for 6.2 owners.

### MORE reasons to get Mac OS 9!

- 1 Sherlock 2
- 2 Multiple Users
- 3 Voiceprint Password
- 4 Keychain
- 5 Automatic Updating
- 6 Encryption
- 7 Internet File Sharing
- 8 Internet AppleScript
- 9 Network Browsing

## Save on Networking Essentials!

**Stack up to 4 units!**  
3Com TP4 OfficeConnect Ethernet Hub



ONLY \$44.98  
#654430

**Get your entire office online!**  
Macsense X-Router Ethernet Router



ONLY \$289.98  
#636446

**Lifetime warranty!**  
Asanté 8-Port 10/100 Hub



ONLY \$124.98  
#85151

**Easy web-based management!**  
Cisco 3512 XL STD Switch



ONLY \$1799.99  
#624943

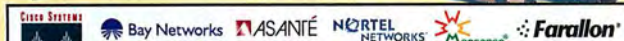

## Scanner Super Values!

**Vibrant 42-bit color!**  
UMAX Astra MX

ONLY \$179.99  
#111169



**Only 1.3 lbs!**

NEC PetiScan

ONLY \$179.99  
#113807



## Storage Solutions!

**Easy to use!**  
Iomega Zip 100 Portable USB Drive

ONLY \$129.98  
#95251



**Fuji 100MB Zip Mac Disks**

- #37185 10-Pk Color \$10 rebate . \$79.99\*
  - #54009 20-Pk Color 4-FREE . . . \$179.99\*\*
  - #86292 2-Pk Gray \$3 rebate . . \$24.99\*
  - #88194 5-Pk Gray \$10 rebate . \$39.99\*
  - #37186 10-Pk Gray \$10 rebate . \$79.99\*
- \*After \$10 mfr. mail-in rebate. \*\*Free disks by mail. Coupon in box. \*After \$3 mfr. mail-in rebate.

**Over twice the storage of the original!**

Iomega Zip 250 Portable USB Drive

ONLY \$179.99  
#650368



AS LOW AS \$14.99\* EACH

**Fuji 250MB Zip Mac Disks**

- #109489 Zip - Single . . . . . \$17.99
  - #115111 Zip - 3pk . . . . . \$49.99
- \*When purchased in 10pk.

**Create your own CDs!**

USB External CD-RW Drive 4X2X8X

ONLY \$299.98  
#107014



AS LOW AS \$2.99 EACH

**Fuji CD-Rewritable Discs**

- CD-RW - Single #59704 \$3.99
- CD-RW - 3-Pack #108422 \$9.99
- CD-RW - 10-Pack #59772 \$29.99
- CD-RW - Single w/4 CD-Rs #105915 \$9.99

## Upgrade Your Mac!

**Increase your processing speed!**  
Newer MAXpowr G3 333 Processor Upgrade



**Blowout!**  
ONLY \$299.97  
#110671

Product shown is representational. \*After \$100 mfr. mail-in rebate.

**Convert your Mac into a G3!**  
Sonnet Crescendo G3 240-266MHz NuBus Upgrade



ONLY \$249.99  
#108674

**Ultimate multimedia graphics!**  
ATI XCLAIM VR 128 16MB PCI Card



ONLY \$159.98  
#613715

\*After \$30 mail-in rebate. Expires 3/31/00

**Award-winning power!**  
XLR8 MACH G3 300 Upgrade



ONLY \$349.99  
#109662

**we're open 24 hours a day 7 days a week**



Credit cards are not charged until the order is shipped. Most products ship the same day (barring system failure, etc.). Shipping options include Ground, 2nd Day and Overnight delivery. Freight is based on average product weight. Handling extra. Insurance available. Special orders may require special shipping and handling charges. Call for international shipping rates. Prices and product availability subject to change without notice. Specials and promotions may be limited to stock on hand. Not responsible for typographical errors. All products sold by Multiple Zones International (MZI) are third party products and are subject to the warranties & representations of the applicable manufacturers, including but not limited to Y2K compliance. Accordingly, MZI makes no representation or warranty with respect to Y2K compliance of product sold. ©2000 Multiple Zones International Inc. All rights reserved. Unauthorized duplication is a violation of applicable laws. Apple, the Apple logo, Macintosh® and PowerBook® are registered trademarks of the Apple Computer, Inc.



# Blowout Prices! absolute lowest price!

## Apple® PowerBook™ G3

### Performance

- Up to 400MHz PowerPC G3 processor
- Up to 1MB backside level 2 cache
- Up to 6GB hard drive
- Up to 10 hours battery life

### Expansion

- PC Card slot
- Hot-swappable expansion bay
- Up to 384MB system memory
- FireWire capable with optional FireWire 2 Go Card

### Connectivity

- Built-in 56K modem
- Built-in 10/100Base-T Ethernet
- Two USB ports (12 Mbps) and SCSI port
- Integrated 4 Mbps IrDA technology

### Multimedia

- 14.1" Active-matrix display
- 24X max. CD-ROM or 2X max. DVD-ROM
- ATI Rage LT Pro graphics accelerator, 8MB VRAM
- S-Video/TV output for easy connection to a TV or VCR

### Style

- 1.7" thin and only 5.9 lbs. with CD and battery
- Full-size keyboard and solid-state Apple trackpad



Own a PowerBook G3 Starting at only **\$58 MO** with the Apple Loan Program! Call to apply today!

**EXCLUSIVE!**  
Up To **\$150**  
**Instant Rebate!**  
on select computers with purchase of hand-held PDA.  
Limited time offer. Offer subject to change.

Call now for complete details!

**2 for 10!** Use 2 batteries for up to 10 hours!



Apple lithium-ion battery

**Compartmentalized expandable notebook case!**



Koskin Notebook Case

**\$200 OFF** ANY purchase at Zones when you open an account with **E\*TRADE™**  
Go to [www.zones.com/etrade](http://www.zones.com/etrade) for details

**For Better Performance...Upgrade your PowerBook's Memory!**  
**PowerBook G3 Memory**

32MB Upgrade #05057	\$99.99
64MB Upgrade #05059	\$139.99
128MB Upgrade #05061	\$219.99

**AppleCare Protection Plan**

- 1 Upgrade from 90-day phone support to 3 Years
- 2 TechTool Deluxe diagnostic software included to fix most problems - \$69 Value
- 3 Exclusive access to AppleCare Web support site
- 4 A total of 3 years of Apple-certified service, both parts and labor
- 5 VALUE... 3 years of protection for only #112696

**5 Reasons to Protect Your PowerBook G3**

**Fits in your pocket!**  
**USB**

MacSense 4-Port USB Mini Hub

**Great durable tote for your notebook!**

Nylon NotePac Case

Pick the PowerBook G3 that's right for you!

Processor	Hard Drive	RAM Std/Max	Backside Cache	Optical Drive	Modem	Display	Graphics ATI Rage Pro	Item #	ONLY	Lease*
G3/333MHz	4.0GB Ultra ATA-33	64MB/384MB	512K L2	CD-ROM	56K	14.1" TFT	128/16MB in AGP 2X slot	#108066	<b>\$2494.98</b>	\$58
G3/400MHz	6.0GB Ultra ATA-33	64MB/1.5GB	1.0MB L2	DVD-ROM	56K	14.1" TFT	128/16MB in AGP 2X slot	#108067	<b>\$3494.98</b>	\$81

\*Business Lease: 36-month, fair-market value lease based on approved credit. Other leasing options available. Leases require a minimum order of \$1000. Call 1-800-611-9751 for details.

**Reads SuperDisks and floppies!**  
**NEW!**

VST SuperDisk Drive for PowerBook G3

**Final Cut Pro Certified**

**Includes QuickTime Pro \$30 Value!**  
Newer Technology  
FireWire 2 Go PC Card

**The ease and convenience of a floppy drive!**

VST Zip 100 Drive for PowerBook G3

**NEW!**

**Pinpoints your location!**  
DeLorme EarthMate GPS for PowerBooks.

**Blazing fast and self-powered!**

VST FireWire 4.0GB Ext. Drive

Corporate bids welcome!  
Fax to 1-800-684-8080

A NASDAQ COMPANY Ticker Symbol: MZON

Circle 71 on card or [www.macworld.com/getinfo](http://www.macworld.com/getinfo)

Source Code  
**MW040**

Order by Phone  
**1.800.436.0606**

Order Online Today  
**Zones.com™**





**BLAZING FAST!**

**MacWAREHOUSE**

# Power Mac G4s

Nikon • Apple • Quark • Kodak • Iomega • PowerUser • Canon

**USB Cables**

Starting at **\$14.99!** ea.

Call for more selection and details!

**250MB Zip USB Drive**

Only **\$179.95!**  
DR11308

- USB compatible
- Backwards compatible
- 56% smaller than original USB Zip Drive

Zip 250MB Disk 4-pack, ask for item #ME8138, only \$69.95

**GL1 Digital Camcorder**

Only **\$2499.95!**  
IN8223

- 20X Optical Zoom
- 100X Digital Zoom
- FireWire input and output • 3 CCD image sensors

warehouse.com/canon/DV

**Update! QuarkXPress 4.1**

Trade-up for only **\$299.95!\***  
SID1004

Precise layout tools and control over every aspect of your document!

QuarkXPress 4.1 Full Version, ask for item #DTP1040, only \$729.95

\*For PageMaker owners. Serial number required at time of purchase. Packaging shown may vary from shipped product.

**Kodak DC290 Zoom Digital Camera**

Only **\$999.95!**  
IN8305

- 3.3 megapixels in Ultra Mode
- 3X optical/2X digital zoom lens

- USB and serial cables included
- 20MB Picture card

# Apple Power Mac G4

As low as **\$1599!**

Lease It! for as low as **\$47/mo.<sup>5</sup>**

Graphite and Ice design!

Up to **450MHz!**



**The Gigaflop is Here!**

The Power Mac G4 runs at over a gigaflop — a billion floating-point operations per second!... and a full 100% to 200% faster running Photoshop than the fastest Pentium® III processor-based PC!\*

\*Based on Apple internal benchmark tests.

**Speed to Burn!**

The next generation of Power Macs™ are built around the blazing PowerPC™ G4 processor to play multimedia and crunch data at lightning-fast speeds! It's the fastest machine ever designed to run graphics applications like Adobe Photoshop, InDesign and QuarkXPress. Blink, and you'll miss it!

Model shown is CPU1553. Monitor sold separately.

**Order Online at**  
[www.macwarehouse.com](http://www.macwarehouse.com)

**More Speed Than Megahertz Alone!**

The speed secret is in the processing — 128-bit chunks, instead of 64 or 32-bit chunks. No wonder a G4 can perform many tasks at twice the speed of a Pentium® III processor\* — even when the megahertz speeds look the same!

**PAGE 1 OF 8**

• Our sales staff is ready to take your order 24 hours a day, 7 days a week. We accept the following major credit cards: Visa, MasterCard, Discover Card/NOVUS, AmEx. Your credit card will not be charged until each item is shipped (no surcharge). CT, IL, NJ and OH residents add applicable sales tax.

• Shipping Charges & Delivery. Overnight delivery for non-GSA orders is \$9.95 per order up to 5 pounds. For all orders over 5 pounds, shipping is \$9.95 plus an additional \$1.80 per pound or fraction thereof. (Example: shipping for a 6 pound order is \$11.75). Please add an additional \$3.00 for orders \$50.00 and under.

• Orders for "in-stock" items placed on weekdays up until 12:00 midnight (E), 11:00 pm (E) for Internet orders, ship same day for overnight delivery (barring system failure, etc.). We anticipate

being able to ship "out-of-stock" items within 30 days.

• Every item we sell comes with our 30-day guarantee against defects. If a product is defective in any way, please call us within 30 days of the original invoice date. You will be transferred to a Technical Support Representative to verify the defect. Upon verification, you will be issued a Return Merchandise Authorization (RMA) number. RMA numbers issued by Micro Warehouse are valid for 15 days only, and the product(s) must be received by Micro Warehouse within that time. RMA numbers cannot be extended or re-issued. Defective software will be replaced upon receipt of the defective product. Defective hardware will be replaced or repaired at our discretion, except for products from Apple (1-800-SUS-APPLE, 1-800-767-2775), Tektronix (1-800-835-

6100), or Minolta printers (1-800-459-3250). These manufacturers must be contacted directly and will repair or replace products at their sole discretion. Should you return hardware to MacWAREHOUSE from Apple or Tektronix, you will be assessed a 15% restocking fee which will be charged to your account. We cannot accept returns of Minolta printers. All returns are subject to the following: 1. All products must be returned in original packaging. 2. Shipping and handling charges are not refundable. 3. Software and consumables are not refundable unless returned unopened in original packaging with documentation. 4. Custom orders and cables are not refundable. 5. Products designated as "all sales final," "no returns," or similar language may not be returned.

Copyright © 2000 Micro Warehouse, Inc. MacWAREHOUSE® is a division of Micro Warehouse, Inc. Item availability and price subject to change without notice. We regret that we cannot be responsible for typographical errors. All prices shown in U.S. dollars. Micro Warehouse makes no representations or warranties of any kind and assumes no liability concerning whether any of the products or services sold by us are Year 2000 Compliant. Year 2000 representations and warranties may be supplied directly to our customers by the manufacturers or publishers of certain products.



We accept these major credit cards.



# Speeds up to 450MHz!

CALL FOR A FREE FULL-COLOR CATALOG!



Nikon • Adaptec • Tektronix • EPSON • AGFA • Apple • Iomega • Quark

## Power Mac G4 Features:

- ✓ PowerPC G4 processor with speeds up to 450MHz
- ✓ Velocity Engine with advanced vector processing
- ✓ Superfast 100MHz system bus and 1MB Backside Level 2 Cache running at half the processor speed
- ✓ Up to 256MB PC100 SDRAM, expandable to 1.5GB
- ✓ Up to 27.0GB ATA/66 hard drive space
- ✓ DVD-ROM or DVD-RAM drives — both with video playback
- ✓ Built-in 100MB Zip drive (CPU1551, CPU1552)
- ✓ 56K modem (CPU1553, CPU1551)
- ✓ Built-in 10/100Base-T Ethernet
- ✓ Built-in antenna and support for optional Airport wireless networking
- ✓ ATI RAGE 128 Pro graphics card with 16MB of graphics memory installed in a 133MHz AGP 2X slot
- ✓ Four expansion slots: three 64-bit PCI slots and one dedicated AGP 2X graphics card slot
- ✓ Three FireWire ports
- ✓ Two USB ports
- ✓ Mac OS 9 system software

Choose the Power Mac G4 that's right for you!

### 350MHz!



#### Power Mac G4/350MHz

350MHz G4 processor/64MB SDRAM/10.0GB Ultra ATA/66 HDD/DVD-ROM with DVD Video Playback/Three FireWire ports/56K modem/Mac OS 9  
**\$1599!**  
 Item #CPU1553.....

Lease It! for as low as \$47/mo.†

### 400MHz!



#### Power Mac G4/400MHz

400MHz G4 processor/128MB SDRAM/20.0GB Ultra ATA/66 HDD/DVD-ROM with DVD-Video Playback/Three FireWire ports/56K modem/Zip Drive/Mac OS 9  
**\$2499!**  
 Item #CPU1551.....

Lease It! for as low as \$73/mo.†

### 450MHz!



#### Power Mac G4/450MHz

450MHz G4 processor/256MB SDRAM/27.0GB Ultra ATA/66 HDD/5.2GB DVD-RAM with DVD-Video Playback/Three FireWire ports/Zip Drive/Mac OS 9  
**\$3499!**  
 Item #CPU1552.....

Lease It! for as low as \$102/mo.†

### Apple 17" Studio Display



Only **\$499!**

- 17" Diamondtron CRT (16" viewable)
- 1600 x 1200 @ 60Hz
- Graphite and ice to match the Power Mac G4

Item #MON1044

### Apple 21" Studio Display



Only **\$1499!**

- 21" screen (19.8" viewable)
- 1600 x 1200 @ 85Hz
- Graphite and ice to match the Power Mac G4

Item #MON1043

### Power Mac G4 Memory



64MB PC100 SDRAM  
 Only **\$199<sup>95</sup>!** each

Item #CHP0689

Memory prices subject to change.

### AGFA 1212U Scanner

Only **\$69<sup>95</sup>!**  
 after \$30 rebate



- Translucent Bondi blue (IN7951)
- Translucent blue (IN8006)
- 36-bit color

\*Price AFTER mfr's \$30 mail-in rebate. See box for details. Offer expires 6/30/00.

### EPSON Stylus Color 850 Printer

Only **\$249<sup>95</sup>!**  
 PR13559



- 9ppm black; 5.5ppm color
- 1440 x 720 dpi
- Mac USB and Serial

USB EPSON

### Nikon CoolPix 950 Digital Camera



Only **\$949<sup>95</sup>!**  
 IN7755

- 2" color LCD • 3X optical zoom
- 2.11 million pixel resolution
- 8MB compact flash stores up to 128 standard images

Nikon

### Adaptec PowerDomain 2930U Ultra SCSI Adapter



Ideal for Power Mac G3 and G4!

Only **\$89<sup>95</sup>!**  
 DR13165

- 20MB/sec. transfer rate
- Internal & external connectors • Bootable

adaptec

### Phaser 840GP Printer



Only **\$399<sup>95</sup>!**  
 PR15354

- 10ppm color/1200dpi
- Adobe PostScript Level 3
- 10/100Base-T
- ColorSync ready

PAGE 2 OF 8

1-800-725-1450 ★ www.warehouse.com/md

ORDER TOLL-FREE 24 HOURS A DAY, 7 DAYS A WEEK! CANADA ORDERS CALL: 1-800-603-5139

MacWAREHOUSE EXPRESS DELIVERY OVERNIGHT!

Your #1 Source for Mac Systems and Products—since 1987!

In-stock items, call weekdays by midnight (E), or order online weekdays by 11pm (E).



Call by Midnight (E) for Overnight delivery!



# \$100 REBATE on iMac 333MHz

Broderbund • Apple • Iomega • Hewlett Packard • Umax • Kensington • Sony

**Stuffit Deluxe**

Only **\$14.95!**<sup>\*</sup> after rebate  
UTI1602

- Mac OS 9 compatible
- Send files faster over the Internet!

**Aladdin Systems**

\*Price AFTER publisher's \$60 mail-in rebate. Before rebate: \$74.95. Rebate applies to owners of previous versions of Stuffit or DropStuff only. Rebate coupon in box. Limit one per customer. Offer expires 3/31/2000.

**USB Floppy Drive**

Only **\$84.95!**  
DRI3296

**VST**

Imation Mac Neon 3.5" Disk 10-pack, only \$5.90 (only 59¢ each!), #MED0540

**HP DeskJet 882c Color Printer**

Only **\$199.95!**  
PR14684

- USB compatible only
- 9ppm blk; 6.5ppm clr • PhotoREt II technology

Black Ink Cartridge, only \$29.99, item #67208.

**iMac USB Hubs**

4-Port only **\$59.99!** ea.

- Stackable up to 127 peripherals

**Xircom** DEH4727: Blueberry DEH4729: Tangerine DEH4725: Lime DEH4726: Grape DEH4728: Strawberry

**UMAX Astra 2100U Color Scanner**

**New Low Price!** Was \$129.95: Now only **\$99.95!**<sup>\*</sup> after rebate  
IN7925

- 36-bit
- 600 x 1200 dpi optical resolution

\*Price AFTER manufacturer's \$30 mail-in rebate. Before rebate: \$129.95. Rebate coupon available at www.warehouse.com/rebate/umax, or call us at 1-800-390-0706 to request one. Offer expires 2/29/2000.

**333MHz Apple iMac**

- 333MHz G3 Processor • 32MB SDRAM (exp. to 256MB)
- 6.0GB hard drive • 24X max. variable CD-ROM
- 56K modem • 10/100Base-T Ethernet
- ATI RAGE Pro Turbo 2D/3D graphics accelerator with 6MB video memory
- 15" color monitor

**HURRY! WHILE SUPPLIES LAST!**

Grape: Item #CPU1337 Lime: Item #CPU1338

**WAS \$1199: NOW ONLY \$799!** ea.  
after MacWAREHOUSE \$100 mail-in rebate.  
Lease It! for \$28/mo.<sup>9</sup>

\*Price for iMac 333MHz G3 computer AFTER MacWAREHOUSE \$100 mail-in rebate. Visit www.warehouse.com/rebate/macwarehouse for mail-in rebate coupon or call us at 1-800-390-0706 to request one. Limit 5 per customer. Rebate only applies to iMac 333MHz G3 computers. Offer not valid on purchase of reconditioned iMac 333MHz G3 computers. Offer expires 2/29/2000 or while supplies last.

**Cooler, Sleeker iMacs - Mixed 3 different ways!**

**1 Apple iMac 350MHz Blueberry**

- 350MHz PowerPC™ G3 processor
- 512K Backside Level 2 Cache
- 64MB of SDRAM (exp. to 512MB)
- 6.0GB Ultra ATA HD drive
- 24x (max. variable) CD-ROM
- Built-in 56K V.90 modem
- ATI RAGE 128 VR 2D/3D graphics accelerator with 8MB SDRAM (AGP 2X)
- Odyssey audio system from Harman Kardon
- 15" color display
- 10/100BASE-T Ethernet
- 2 USB ports (12Mbps ea.)
- Support for AirPort 11Mbps wireless networking (antenna built-in; AirPort card optional)

Only **\$999!**  
#CPU1492  
Lease It! for \$29/mo.<sup>6</sup>

**2 Apple iMac DV 400MHz**

Includes ALL the GREAT Features of the 350MHz Model - PLUS -

- 400MHz Processor
- Slot-loading DVD drive
- Movie-making software
- Two FireWire ports
- 10.0GB Ultra ATA HD drive

Only **\$1299!** each  
Lease It! for \$38/mo.<sup>1</sup>

Lime: Item #CPU1496	Blueberry: Item #CPU1493	Strawberry: Item #CPU1495	Tangerine: Item #CPU1497	Grape: Item #CPU1494
---------------------	--------------------------	---------------------------	--------------------------	----------------------

**IDOCK 2 USB MULTI-PORT HUB**

**COMPU-CABLE**

- Floppy drive
- Swivel Base
- 4 USB ports
- 2 Serial ports
- 1 ADB ports

Includes 3.5 floppy drive!

Only **\$259.99!**  
Item #DEH4620

**MYST**

**FREE\*** with any purchase from MacWAREHOUSE  
Item #AAA0742

• Challenge your puzzle-solving skills in the Island world that is Myst!

\*\$3.95 shipping and handling applies. Shipped in promotional packaging. Hurry! Offer good while supplies last.  
\*\*Value based on MacWAREHOUSE pricing as of this magazine printing.

**Value \$29.95! Value**

Broderbund

**Orbit USB for Mac**

Only **\$49.95!**

Ask for item #INP1761.

- Designed specifically for use with USB
- Fits the natural shape of your hand; ideal for right- or left-handed users
- Manufacturer's 5-year warranty

**KENNINGTON**

**HP DeskJet 895cse Printer**

Only **\$249.95!**

Ask for item #PR14208.

- 11ppm black • 8.5 ppm color
- PhotoREt II technology • USB compatible

Black Ink Cartridge, only \$29.99, item #67208.

**Sony Digital FD73 Mavica**

Only **\$499.95!**

Ask for item #IN7834.

- 10x optical zoom • E-mail mode • 2.5" Color LCD • VGA resolution • Quick Access 2X Floppy Disk Drive • Picture effect • File copy/disk copy

**SONY**



# G3 computers!

Now only **\$799!**\* each,  
after MacWAREHOUSE \$100 mail-in rebate.



VST • Epson • Aladdin • Xircom • Farallon • Microsoft • XLR8 • Intuit

## 3 Apple iMac DV Special Edition

- 400MHz PowerPC™ G3 processor
- 512K Backside Level 2 Cache
- 128MB of SDRAM (exp. to 512MB)
- ATI RAGE 128 VR 2D/3D graphics accelerator
- 13.0GB Ultra ATA HD drive
- 4X max. DVD-ROM drive
- Built-in 56K V.90 modem
- 15" color display
- Harman Kardon Odyssey Audio System
- 10/100BASE-T Ethernet
- Dual FireWire ports
- Two 12Mbps USB ports
- Support for AirPort 11Mbps wireless networking (antenna built-in; AirPort card optional)
- Preinstalled iMovie software

Only **\$1499!**  
#CPU1498  
Lease It! for \$44/mo.\*



• Cool See-thru Graphite Housing!  
• 128MB RAM!  
• 13.0GB HD!  
**400MHz!**

### Get MORE POWER for your 350 — 400MHz iMac!

Our Apple Authorized technicians will install your RAM for only \$29.95 when you purchase your new iMac and memory upgrade together!

Size/Type	Item #	Price
32MB PC100	CHP1041	\$149.95
64MB PC100	CHP1037	\$299.95

Ask for item #INSTL30.

Memory prices subject to change.

### Omega 100MB USB Zip Drive

Only **\$129.95!**  
DR9464  
Zip Disk sold separately.

Omega 100MB Zip Disks  
as low as **\$8.99!** each, in 20-pk.  
20-pack (gray): only \$179.80, #BND3616.

### EtherMac iMac iPrint Adapter with built-in PhoneNet!

Only **\$104.99!**  
DEP1734  
• Connects your iMac to LocalTalk printers and other Macs  
• Easy plug-and-play installation  
• Ethernet iPrint Adapter for Stylewriter, only \$79.99, #DEP1739.

### XLR8 InterView

Was \$99 Now Only **\$79!**  
DRI3561  
• Captures audio/video through USB interface  
• Includes Strata Videoshop 4.5

### Intuit MacInTax Bundle

Only **\$69.95!**\* after rebate  
TX1263  
Includes:  
• Quicken Deluxe 2000  
• MacInTax Deluxe  
• MacInTax State\*\*

\*Price AFTER publisher's \$60 mail-in rebate. Before rebate: \$129.95. Shipped in promotional packaging. Offer expires 3/31/2000 or while supplies last.  
\*\*State product delivered via download from publisher. Details in box.

### Microsoft Word 98 Special Edition!

Only **\$89.95!**\* after rebate  
WP3072  
Includes Word 98, Internet Explorer 4.5 and Outlook Express 4.5.  
\*Price AFTER publisher's \$30 mail-in rebate. Before rebate: \$119.95. Rebate coupon in box. Offer expires 3/31/2000.

PAGE 4 OF 8

### MICROSOFT OFFICE 98

Microsoft Includes:

- Word 98 • PowerPoint 98
- Excel 98 • Outlook Express.

Upgrade only **\$249.95!**  
Item #UPG0778



Microsoft Office 98 Full Version BUST150 ..... \$419.95

§ Leases are only available to business customers with approved credit on product orders where at least one product totals \$750 or more. Lease payments are based on a 48-month Lease. Call today to see how you can qualify. Lease terms are subject to change.

### EPSON STYLUS COLOR 740i PRINTER

- Blueberry cover standard
- 1440 x 720 dpi with smaller ink drops • 6ppm blk; 5ppm clr
- USB/Mac serial compatible

Other color covers available for only \$14.95 each! Call for details.

Only **\$179.95!**\* after \$50 rebate  
Item #PR15063

\*Price BEFORE manufacturer's \$50 mail-in rebate is \$229.95—\$50 rebate=\$179.95. Rebate coupon available at www.warehouse.com/rebate/epson, or call us at 1-800-390-0706 to request one. Offer expires 3/31/2000.



Black Ink Cartridge: PA1582..... \$29.99

**1-800-725-1450** ★ **www.warehouse.com/md**

ORDER TOLL-FREE 24 HOURS A DAY, 7 DAYS A WEEK! CANADA ORDERS CALL: 1-800-603-5139

**MacWAREHOUSE** EXPRESS DELIVERY OVERNIGHT!

Your #1 Source for Mac Systems and Products—since 1987!

In-stock items, call weekdays by midnight (E), or order online weekdays by 11pm (E).



Call by Midnight (E) for Overnight delivery!





# Apple - Fast, Loaded,

Apple • Newer Technology • Global Village • Imation • 3Com US Robotics • Xircom

**MYST**  
**FREE!**  
 with any purchase from MacWAREHOUSE AAA0742  
 A \$29.95 Value! \*\*

• Challenge your puzzle-solving skills in the Island world that is Myst!  
 \*\$3.95 shipping and handling applies. Shipped in promotional packaging. Hurry! Offer good while supplies last.  
 \*\*Value based on MacWAREHOUSE pricing as of this magazine printing.

**USB to Serial**

**Only \$59.99!**  
**DAD1665**

• Use your Mac or iMac USB port to connect serial modems, digital cameras, graphic tablets, printers, and PDAs  
 • Supports either the Mac modem or printer port

**3Com Palm Vx with Mac Pac v.2 software**

**Only \$409!**  
**BN7020**

• Stylish, ultra-thin design  
 • 8MB of memory

**Olympus D-450Z**

**1.3 MEGAPIXEL!**

**Only \$499.95!**  
**IN8167**

• 1.3 megapixel res.  
 • 3X optical/2X digital zoom  
 • 8MB Smartmedia card included

**SupraExpress V.90 56K Modem**

**Only \$79.99! \*\***  
 after rebate  
**DMD3503**

\*Capable of receiving data up to 56Kbps. Actual send and receive speeds may vary.  
 \*\*Price AFTER manufacturer's \$20 mail-in rebate. Price before rebate: \$99.95. Rebate coupon available at [www.warehouse.com/rebate/diamond](http://www.warehouse.com/rebate/diamond) or call us at 1-800-390-0706. Offer expires 3/31/2000.

## HP LaserJet Printers

**HP LASERJET 8000N**  
**Only \$2489.95!**  
 Ask for item #PR13724.  
 Lease It! for \$72/mo.\*

• Prints 24ppm • 1200 dpi max. resolution  
 • 133MHz RISC processor

**HP LASERJET 2100M**  
 • Prints 10ppm  
 • 1200 dpi resolution  
 • HP PostScript Level 2  
 • LocalTalk connectivity

**HP LASERJET 2100 SERIES BLACK TONER CARTRIDGE**  
 Only **\$109.95 ea.**  
 Item #PA1871

**HP LASERJET 8000 SERIES BLACK TONER CARTRIDGE**  
 Only **\$179.95 ea.**  
 Item #63223

**HP LASERJET 4050N**  
**Only \$1399**  
 Ask for item #PR14947.  
 Lease It! for \$41/mo.\*

• Prints 17ppm  
 • 1200 dpi maximum resolution  
 • 100MHz RISC processor  
 • Ethernet 10Base-T/10Base-2 + LocalTalk

**HP LASERJET 5000N (not shown)**  
 • Prints 16ppm • 1200 dpi • Prints 3" x 5" thru 11" x 17"  
 Ask for item #PR13443 .....Lease It! for \$58/mo. .... **\$1999.95**

**HP LASERJET 4050 SERIES BLACK TONER CARTRIDGE**  
 Only **\$94.95 ea.**  
 Item #PR13025

**HP LASERJET 5000 SERIES BLACK TONER CARTRIDGE**  
 Only **\$169.99 ea.**  
 Item #PR13742

**MAC OS 9**

**Upgrade only \$69.95!\***  
 after \$30 in rebates  
**Item #SYS1012**

**FREE! SOFTWARE BUNDLE!**  
 Including Spring Cleaning and many other software titles, with the purchase of Mac OS 9.  
 Ask for Item #AAA1043.

**PLUS... FREE! iTools from Apple**  
 with purchase of Mac OS 9!

**Features you'll love!**

- Sherlock 2: Easily find people, news, and shopping on-line!
- Easy-to-use, functional interface
- Compatibility with popular search engines such as AltaVista, CNET, Excite, Infoseek, and Lycos
- Plug-ins that search popular sports, financials, and news sites such as CNN and ESPN
- Ability to search multiple shopping and e-commerce sites at the same time
- Built-in Open GL for accelerated 3-D graphics and an improved gaming experience

\*Price AFTER Apple \$20 mail-in upgrade rebate and MacWAREHOUSE \$10 mail-in rebate. Before rebates: \$99.95. Apple rebate requires proof of ownership for OS 8.5, OS 8.5.1 or OS 8.6. Rebate coupon in box. Offer expires 5/1/2000. MacWAREHOUSE rebate limit one per customer (or 5 per customer site.) MacWAREHOUSE rebate coupon available at [www.warehouse.com/rebate/applesoftware](http://www.warehouse.com/rebate/applesoftware) or call us at 1-800-390-0706. Not to be combined with other MacWAREHOUSE offers. Rebate expires 3/31/2000.  
 †\$3.95 shipping & handling applies.  
 ††iTools is free to Macintosh® users running the Mac OS 9 operating system, and can be accessed at [www.apple.com](http://www.apple.com). See box for details.

**VIEWSONIC P810 21"**

• 21" screen (20" viewable)  
 • .25mm dot pitch  
 • 1800 x 1440 @ 73HZ resolution  
 • Manufacturer's 3-year warranty

**Only \$911.95!**  
**Item #MT3320**

**IONEGA 100MB ZIP DISKS**

**FREE CD-R 10-pack**  
 when you buy a 100MB Zip Disk Color 10-pack!  
 While supplies last.  
 Item #AA1740.

**New Low Price! \$8.99!**  
 each, in 20-pack  
**Item #BND3616**

100MB Zip Disk Gray (20-pack) BND3616 ..... \$179.80  
 100MB Zip Disk Color (10-pack) BNS265 ..... \$99.95

**Imation CD-Rs**

**Only 99¢ each,**  
 in 100-pack  
**Ask for item #ME8572. (only \$99)**

• 74 min. • 650MB

**IMATION**

**3Com U.S. Robotics 56K\* V.90 FaxModem**

**Only \$99.99!**  
**Ask for item #DMD3448.**

• Manufacturer's lifetime warranty  
 • Capable of receiving data up to 56Kbps.  
 Actual send and receive speeds may vary.

**Amazon Inkjet Cartridges**

**FREE! InkJet Cartridge**  
 with the purchase of an inkjet cartridge 4-pack.

As **\$22.95!** each,  
 low as **\$22.95!** each, in 4-pack

4-Pack Black Ink cartridges for Epson Stylus Color 740/740i/1160: Item #PA2315 ..... \$91.80  
 4-Pack Color Ink cartridges for Epson Stylus Color 440/640/740/740i/1160: Item #PA2317 ..... \$91.80  
 \*Free cartridge shipped in package.



# and Ready to Go! Only \$1599!



Hewlett Packard • ViewSonic • Iomega • Olympus • BroderBund • Amazon • Targus

## Apple iBook – 300MHz G3 Power!

Packed with power and wrapped in a stunning notebook design!



- 300MHz PowerPC G3 processor
- 512K Backside Level 2 Cache
- 32MB SDRAM • 3.2GB IDE hard drive
- 24X max. variable CD-ROM
- 56K V.90 modem • 10/100 Base-T Ethernet
- Wireless networking with optional AirPort card and base (sold separately)
- 12.1" Active-Matrix Display
- ATI Rage Mobility 2D/3D Graphics Accelerator with 2X AGP
- USB port • 4MB Video Memory
- Lithium-ion battery—up to 6 hours of use!

Blueberry Item #CPU1463  
Tangerine Item #CPU1464

**300MHz!**

Order Online at [www.macwarehouse.com](http://www.macwarehouse.com)

Only **\$1599!** ea.  
Lease It! for \$47/mo.<sup>5</sup>



Additional Lithium-ion Battery  
Item #ACC3804 ..... \$129

### 120MB SuperDisk Drive



Only **\$129.99!**\*  
DR10760 after rebate

- Reads and writes 3.5" floppies
- USB & Hot-Swappable!
- IMATION 120MB SuperDisk Media 10-pack, only \$69.90\*\* (only \$6.99 ea.), #BND3239.
- \*Price AFTER manufacturer's \$20 mail-in rebate. Before rebate: \$149.99. Rebate expires 3/31/2000.
- \*\*Price AFTER manufacturer's \$30 mail-in rebate on 10-pack. Before rebate: \$99.90. Rebate expires 6/30/2000. Rebate coupons are available at [www.warehouse.com/rebate/imation](http://www.warehouse.com/rebate/imation) or call 1-800-390-0706 to request them.

### Targus Universal Notebook & Printer Case

Only **\$69.95!**  
AC28478



- Two individual padded compartments that measure 11" x 13" x 2.5"

### PowerBook G3 Battery

As low as **\$139.95!**  
ACC3728



- Lithium-ion
- ACC3728 (fits new 1999 models), only \$139.95
- ACC3307 (fits 1998 models) shown, only \$199.95

### 56K PC Card FaxModem

Only **\$149.95!**  
DMD3824



- K56 Flex and V.90 technology
- Send, receive, view, print, and manage faxes right from your PowerBook
- Capable of receiving data up to 56Kbps. Actual send and receive speeds may vary.

### FireWire 2 Go

Add FireWire to your PowerBook G3!

Only **\$159!**  
DRI3505  
Fits in CardBus slot



### 333MHZ POWERBOOK G3

- 333MHz PowerPC G3 processor
- 64MB SDRAM • 4.0GB IDE HD
- 24X max. variable CD-ROM
- 56K Modem • 14.1" Active-Matrix Display • 512K Backside Level 2 Cache

PowerBook G3 only **\$2499!**

Lease It! for \$73/mo.<sup>4</sup>  
Item #CPU1359

<sup>4</sup>Buy any qualifying PowerBook G3 and receive a FREE Battery. Ask for item #AAA1069. While supplies last. Offer not valid on purchase of reconditioned PowerBooks.

### FREE! Apple PowerBook G3 Battery!

with purchase of an Apple PowerBook. Ask for item #AAA1069. While supplies last!



### 400MHZ POWERBOOK G3

- 400MHz PowerPC G3 processor
- 64MB SDRAM • 6.0GB IDE HD
- DVD-ROM • 56K Modem
- 14.1" Active-Matrix Display
- 1MB Backside Level 2 Cache

PowerBook G3 only **\$3499!**

Lease It! for \$102/mo.<sup>4</sup>  
Item #CPU1360

<sup>4</sup>Buy any qualifying PowerBook G3 and receive a FREE Battery. Ask for item #AAA1069. While supplies last. Offer not valid on purchase of reconditioned PowerBooks.

### FREE! Apple PowerBook G3 Battery!

with purchase of an Apple PowerBook. Ask for item #AAA1069. While supplies last!



### iBOOK/POWERBOOK G3 MEMORY

Upgrading your memory is the most cost-effective way to increase the performance of your system!

32MB iBook, PowerBook G3 Memory only **\$99.95!** each  
Item #CHP9820

Memory prices subject to change.

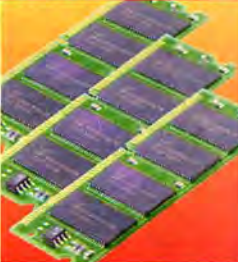

### AIRPORT CARD & STATION

- Transmits up to 150 feet
- Speeds up to 11MB per second

Wireless Internet Access!

AirPort Card for iBook only **\$99!**  
Item #DEC3878

AirPort Base Station for iBook (shown) #DEB2555 ..... \$299



PAGE 6 OF 8

1-800-725-1450 ★ [www.warehouse.com/md](http://www.warehouse.com/md)

ORDER TOLL-FREE 24 HOURS A DAY, 7 DAYS A WEEK! CANADA ORDERS CALL: 1-800-603-5139

**MacWAREHOUSE** EXPRESS DELIVERY OVERNIGHT!

Your #1 Source for Mac Systems and Products—since 1987!

In-stock items, call weekdays by midnight (E), or order online weekdays by 11pm (E).







# Adobe Photoshop 5.5

Apple • 3Com • Global Village • Imation • Imation • Mitsubishi • Iomega • Microtek

## Olympus C-2020 Digital Camera

New Low Price!

Was \$899:  
Now only  
**\$799.95!**  
IN8346



4 "AA" NIMH Batteries, Remote, and 8MB Card Included!

- 2.1 Megapixel
- 3X optical zoom • 1600 x 1200 ppi res.
- QuickTime movie mode (up to 60 seconds)

**OLYMPUS**

Olympus P330 Stylus Photo Printer, ask for item #PR14784, only \$399.95

## 32MB SmartMedia Cards

Only  
**\$99.95!**  
MY11858



- Digital film for digital cameras
- Compatible with new digital cameras with SmartMedia slot

## Microtek ScanMaker 4

Only  
**\$599.95!**  
IN8332



- 36-bit color
- 600 x 1200 dpi
- Built-in transparency & slide bay
- 8.5" x 14" scanning area

FREE! Snaptrans templates!

MICROTEK

†With the purchase of ScanMaker 4. Templates shipped in ScanMaker box. While supplies last.

## Imation 8X CD-Rs

Only  
**99¢** each,  
in 100-pack, on spindle  
ME8572 (Only \$99)



IMATION

## 3Com Palm Vx

New Low Price!

Was \$429:  
Now only  
**\$399!**  
BN7020



- New sleek design
- 8MB of memory

PAGE 7 OF 8



Authorized Catalog Reseller

# Apple 333MHz iMacs

only **\$799!** each

Order Online at  
[www.macwarehouse.com](http://www.macwarehouse.com)

**Apple iMac 350MHz**

- 350MHz • 64MB SDRAM
- 6.0GB HD • 24X max. CD-ROM
- 56K modem • 15" monitor

Blueberry only  
**\$899!**  
Item #RCPU1492

**Apple iMac 400MHz DV**

- 400MHz • 64MB SDRAM • 10.0GB Ultra ATA HD
- 4X DVD-ROM • 56K modem • 15" monitor

Only  
**\$1199!** ea.

Blueberry: #RCPU1493 • Grape: #RCPU1494 • Lime: #RCPU1496  
Strawberry: #RCPU1495 • Tangerine: #RCPU1497

**Apple iMac DV Special Edition**

- 400MHz • 128MB SDRAM
- 13.0GB Ultra ATA HD • 4X DVD-ROM
- 56K modem • 15" monitor

Graphite only  
**\$1399!** Item #RCPU1498

While supplies last!

**APPLE 333MHz IMACS: 5 COLORS TO CHOOSE FROM!**

- 333MHz PowerPC G3 processor
- 32MB SDRAM (256MB max.)
- 6.0GB hard drive
- 24X max. variable CD
- 56K modem
- 15" color monitor

- Lime: Item #RCPU1338  
Grape: Item #RCPU1337  
Tangerine: Item #RCPU1340  
Blueberry: Item #RCPU1336  
Strawberry: Item #RCPU1339



RECONDITIONED



Blueberry, shown.

Only **\$799!** each

## POWER MAC 7200/90MHZ

- 90MHz PowerPC 601 processor
- 16MB RAM • 500MB HD
- 4X max. variable CD-ROM
- 3 PCI Slots

Only  
**\$399!**  
Item #RCPU1471

\*Reconditioned system. Reconditioned computers may not include original application software. 90 day parts and labor warranty. All sales final. While supplies last. Monitor and keyboard not included.

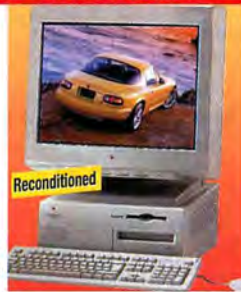

## POWER MAC G4/350MHZ

- 350MHz PowerPC G4 processor
- 64MB SDRAM • 10.0GB Ultra ATA/33 Hard Drive • 32X max. variable CD • 56K modem
- 1MB Backside Level 2 cache
- 2 USB ports • 2 FireWire ports

Only  
**\$1299!**  
Item #RCPU1513

\*Reconditioned system. Reconditioned computers may not include original application software. 90 day parts and labor warranty. All sales final. While supplies last.



Reconditioned

While supplies last!

## DIAMOND PRO 900u 19" MONITOR



- 1600 x 1200 @ 75Hz
- 18" viewable size
- .25 aperture grille
- Manufacturer's 3-year warranty

Only  
**\$634.95!**  
Item #MON0765

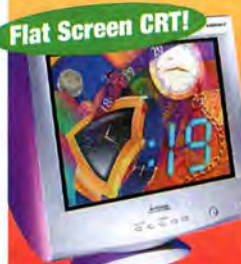

Flat Screen CRT!

## VIEWSONIC P810 21" MONITOR



Ideal for graphic applications!

- 21" monitor (20" viewable)
- 1800 x 1440 @ 73Hz
- .25mm dot pitch

Only  
**\$911.95!**  
Item #MT3320



FREE\*  
CD-R 5-pack  
when you buy 1 Jaz 2.0GB  
cartridge. #AA1709

## Jaz 2.0GB Cartridges

Only **\$99.95!** each,  
in 3+ quantity

Ask for item #MED0508.  
Quantity: 1-2 3+  
Price: \$124.95 ea. | \$99.95 ea.

\*Limit 1 per customer. While supplies last. Ask for item #AA1709.

## Epson ELP 5700i Laser Printer\*\*

Only **\$349.95!** after mfr's \$50  
mail-in rebate

Ask for item #PR15675.  
\*8ppm • Up to 1200 dpi • USB compatible only  
\*\*Price BEFORE mfr's mail-in rebate is \$399.95 - \$50  
rebate = \$349.95. Rebate coupon in box. Offer expires 3/31/2000.  
\*\*\*Optional blueberry or grape cover available. Redeem through mfr's mail-in coupon in box.



## Global Village 56K Teleport Internal Mac Modem

Only **\$64.99!** after mfr's \$20  
mail-in rebate

Ask for item #DMD4267.



\*Capable of receiving data up to 56Kbps. Actual send and receive speeds may vary.  
†Price AFTER mfr's \$20 mail-in rebate. Rebate coupon available at [www.warehouse.com](http://www.warehouse.com).  
Rebate/globalvillage or call 1-800-390-0706 to request one. Offer expires 3/31/2000.



# Upgrade as low as \$109<sup>95!</sup>

after \$70 rebate.  
Item #UPG1049

CALL FOR A FREE FULL-COLOR CATALOG!



MacWAREHOUSE  
Data CommWAREHOUSE

Olympus • Epson • ATI • ViewSonic • Sony • Adobe • Macromedia



## Adobe Photoshop 5.5

Upgrade only **\$109<sup>95!</sup>\***

after rebate for previous owners of Photoshop 5.0 and ImageReady 1.0

Ask for item #UPG1049.

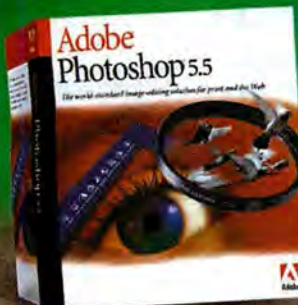
- Multiple undo: Quickly undo or redo several steps.
- Magnetic Tools: Precisely follow the edges of an image.

Adobe Photoshop 5.5 Upgrade (from Photoshop v4.0 or earlier) UPG1049 .....\$179.95

Adobe Photoshop 5.5 (Full Version) GRA2951 .....\$599.95

Adobe Photoshop LE: GRA2973 .....\$99.95

\*Price AFTER publisher's \$70 mail-in rebate for previous owners of Adobe Photoshop 5.0 or ImageReady 1.0. Before rebate: \$179.95. Rebate coupon included in box. Rebate must be postmarked no later than 5/15/2000 to qualify.

---

### Adobe Collections!

**Publishing Collection** (Photoshop 5.5, PageMaker 6.5 Plus, Illustrator 8.0, and Acrobat 4.0.) Item #GRA2975 .....\$949.95

**Web Collection** (Photoshop 5.5, GoLive 4.0, and Illustrator 8.0) Item #COM1215 .....\$949.95

**Design Collection** (Photoshop 5.5, InDesign 1.0, Illustrator 8.0, and Acrobat 4.0.) Item #GRA2974 .....\$1589.95

**Dynamic Media Collection** (Premiere 5.1, After Effects 4.0, Photoshop 5.5, and Illustrator 8.0) Item #GRA3007 .....\$1489.95

---

### Adobe InDesign

Only **\$699<sup>95!</sup>**

Page layout and design for the future of professional publishing! Adobe InDesign delivers a level of integration, creative freedom, productivity, and precision unmatched by other page layout programs. Get started quickly with InDesign by easily converting QuarkXPress® documents to InDesign format.

Ask for item #DTP0693.

---

### Free! \*\*

**Silvertone 1.5 Extended Process Separator™** (by Intense Software) with purchase of Adobe Photoshop 5.5. Item #AAA1020.

A \$249 Value!

This Photoshop plug-in enables 8-color separations.

\*\*\$3.95 shipping and handling applies. Shipped in promotional packaging on CD-ROM. HURRY! While supplies last.

†Value based on MacWAREHOUSE pricing as of this magazine printing.

## New! Dreamweaver 3

Upgrade only **\$119<sup>95!</sup>**

UPG1157

- QuickTag Editor for editing code at the object level
- History Palette and "Repeat Last Action" feature
- Apply global styles and convert tables to layers



macromedia add life to the web

---

### Sony Digital FD83 Mavica

Only **\$699<sup>95!</sup>**

IN7856

- XGA resolution 1024 x 768ppi, 1216 x 916 interpolated
- 3x Optical Zoom/6x Digital
- 4x High speed floppy disk
- Audio & Video out • 2.5" LCD

MPEG/Voice recording modes included

SONY

### Special Limited Time Offer! CoreIDRAW 8

Only **\$79<sup>95!</sup>\***

GRA3121

A Software Collection for illustration, page layout, photo editing, and more!



\*Offer good while supplies last.

### COMPACT FLASH CARDS

- Digital film for storing pictures
- Compatible with all digital cameras

**8MB Storage Card** Only **\$39<sup>95!</sup>** Item #MY7648

**48MB Storage Card** Only **\$129<sup>95!</sup>** Item #MY10017

Digital film for your digital camera!



### NEXUS 128 GRAPHICS ACCELERATOR

- Ultra fast graphic accelerator board
- Rage 128 graphics accelerator
- Supports high resolutions up to 1900 x 1200
- 32MB memory

ATI

Only **\$219!**

Item #DRI3236



### Extended On-Site Support\*

Here are seven great reasons to get complete system coverage:

- Toll-Free Technical Help
- Fast On-Site Support—uplifts manufacturer's warranty to on-site 100% coverage for qualifying products
- Free Replacement if unit cannot be repaired!
- No Deductible—100% coverage on parts and labor!
- 24-, 36-, and 48-Month Coverage—available from date of purchase!
- Fully Insured—Program underwritten by an "A-Excellent" rated insurer
- Fully Transferable—Even if you move or sell the equipment, full coverage remains in effect.

Service you can depend on! Consult the chart below to see which warranty best fits your needs:

Cost of Computer and/or Peripherals	Warranty Price (36 months)	Ask for Item #
\$701 - \$1,200	\$149.99	MW3003
\$1,201 - \$2,000	\$189.99	MW3004
\$2,001 - \$3,000	\$219.99	MW3005

Call your Account Manager for terms and other pricing options.

Call your customer service representative to get extended support for just pennies a day!

\*Note: This promotion is not a service agreement, but an outline of coverage available through Service Net. Please call Micro Warehouse, Inc. for information and read the complete Service Agreement from Service Net, for exact coverages, terms, and conditions. Coverage begins after a manufacturer limits its warranty in any way. Plan not available on international orders.

### NORTON UTILITIES 5.0

- Prevents computer disasters
- Optimizes hard disk performance
- Speeds recovery from emergencies

Upgrade Only **\$49<sup>95!</sup>\***

after \$50 upgrade rebate.  
Item #UTI1546

\$50 Upgrade Rebate!



\*Price AFTER publisher's \$50 mail-in upgrade rebate. Before rebate: \$99.95. Rebate applies to owners of previous versions of Norton Utilities for Mac and Norton AntiVirus for Mac. Rebate coupon in box. Offer good through life of product.

### WWW.WAREHOUSE.COM

Get a FREE\* gift when you order online.

Every time you order from our full line of Mac products on the Web, you can get a FREE\* Gift! Choose from Myst CD, Solitaire Mania/Video Casino, Hot Door Transparency and more!

\*\$3.95 shipping and handling applies. Limit one per customer per order. Shipped in promotional packaging. While supplies last.



See our BLOWOUT SPECIALS and SUPER OFFERS — every day! Place your order online by 11pm (E) and get it the next day!

Micro Warehouse

Call your Account Manager for terms and other pricing options.

Call your customer service representative to get extended support for just pennies a day!

\*Note: This promotion is not a service agreement, but an outline of coverage available through Service Net. Please call Micro Warehouse, Inc. for information and read the complete Service Agreement from Service Net, for exact coverages, terms, and conditions. Coverage begins after a manufacturer limits its warranty in any way. Plan not available on international orders.

**PAGE 8 OF 8**

# 1-800-725-1450 ★ www.warehouse.com/md

ORDER TOLL-FREE 24 HOURS A DAY, 7 DAYS A WEEK! CANADA ORDERS CALL: 1-800-603-5139

## MacWAREHOUSE EXPRESS DELIVERY OVERNIGHT!

Your #1 Source for Mac Systems and Products—since 1987!

In-stock items, call weekdays by midnight (E), or order online weekdays by 11pm (E).



Call by Midnight (E) for Overnight delivery!



# iMacs Starting

## iMacs for the new Millennium— 400MHz, Digital Video, Stereo Sound!

**S**tart out the millennium right, with the most popular computer in the world—the Apple iMac™.

The translucent, incredibly easy to use iMac is cause for celebration. With speeds up to 400MHz, the iMac is the best choice for playing games, listening to music and searching the Web with Apple's Sherlock 2. And with iMac DV models, not only can you watch movies, you can finally make your own.



### Processor and Memory

- 350 or 400MHz Power PC G3 Processor
- 512K backside level 2 cache on processor module
- 100MHz system bus
- 64 or 128MB of PC100 SDRAM; two SODIMM slots support up to 512MB
- 64-bit memory bus

### Storage

- Internal 6, 10 or 13GB Ultra ATA hard disk drive
- Internal 24X (maximum) slot-loading CD-ROM drive or DVD-ROM Drive (DVD is in DV models only)

### Communications

- Built-in 56K V.90 modem
- Built-in 10/100BASE-T ethernet
- AirPort wireless networking slot for optional AirPort card; runs at 11Mbps with 150 foot maximum range

### Connectivity

- Two high speed Universal Serial Bus (USB) ports (12 Mbps), which support USB devices such as keyboard, mouse, printer, storage devices, and USB hubs
- Two 6-pin FireWire ports running at up to 400Mbps (DV models only)

### Multimedia capabilities

- Built-in 15" shadow mask CRT (13.8-inch diagonal viewable image size), .28mm dot pitch
- Three crisp resolutions: 640 X 480 pixels at 117Hz; 800 X 600 pixels at 95Hz; 1024 X 768 pixels at 75Hz
- ATI RAGE 128 VR accelerated 2D/3D graphics controller with 8MB video memory and AGP 2X support
- 24-bit true color at all resolutions for displaying millions of colors
- Refresh rate of up to 117Hz

### Outstanding Audio Features

- Integrated high-performance Odyssey audio system from Harman Kardon
- Built-in microphone for speech recognition and audio recording
- Front mounted, dual mini-headphone jacks
- Minijacks for 16-bit CD-quality stereo input/output; 44.1-kHz sampling rate
- Supports external USB audio devices

### Video (DV models only)

- Standard VGA 15-pin mini D-sub output port
- Supports video mirroring (external devices display an image identical to that shown on the built-in display)

### Software

- Mac OS pre-installed
- AppleWorks, Adobe PageMill, much more!

350MHz iMac

only **\$999**

#56399 (Blueberry only)

64MB RAM; 6GB Hard Drive; 24X CD-ROM Drive; 56K modem

Protect your investment with a  
New AppleCare Warranty  
from MacMall!

### IntelliNews

News, weather, sports and more, delivered right to your desktop!

FREE w/iMac purchase.

a '1999 value!

**New!**

Call or visit  
macmall.com for  
more information.



# MacMall Exclusive! Up to \$250 Cash Back!

Purchase Any Product  
Over \$799 and Get Instant  
Cash Back up to \$250!

If Product Price is Between	You Get EXCLUSIVE Cash Savings
\$799-1199	\$25 Gift Cheque
\$1200-1799	\$50 Cash Back
\$1800-2899	\$100 Cash Back
\$2900-3399	\$150 Cash Back
\$3400-4399	\$200 Cash Back
\$4400+	\$250 Cash Back

All offers are subject to change. Limit 1 free offer per customer. Sales tax and shipping do not qualify as part of product price total. Valid only on regular in stock items—special order and clearance items do not apply. Not valid with any other offer.

Call now or visit  
macmall.com for details

Limited time offer. Valid until 4/3/00.



Order Any Time! Open 24 Hours!  
Order Today by 10 pm EST—  
Get it Tomorrow by 10:30 am!

# 1-800-217-9492



# at \$999!

## The iMac Meets the Movies!



Introducing iMovie.  
Now you can make  
your own movies!

Canon Ultrama Mini  
DV Camcorder

only \$949<sup>95</sup> #48822

iMovie software is pre-installed on all DV iMacs and allows you to rearrange scenes, cut out boring parts, cut and paste text and graphics and add sound and music! All you need to do is connect your camcorder to your iMac's built-in FireWire port and launch iMovie! Ready, set, action!

## 400MHz iMac DV Models

Want to play movies or even make some of your own? An iMac DV model is your personal theatre for viewing DVD movies. Simply connect your favorite DV camcorder to the FireWire port and use Apple's ground-

breaking iMovie software to create your own digital movies. iMac DV models also include built-in video mirroring for making presentations!

### All models include:

- ▶ 400MHz ▶ 64MB RAM ▶ 10GB HD
- ▶ 56K Modem ▶ 10/100BASE-T

- #56401 Grape • #56402 Tangerine
- #56403 Strawberry • #56404 Lime
- #56405 Blueberry



only \$1,294!

or Lease for \$52/mo.

Protect your investment with a  
New AppleCare Warranty from MacMall!

Call for our full line of peripherals,  
**USB**  
UNIVERSAL SERIAL BUS  
Visit [macmall.com](http://macmall.com)

## iMac DV Special Edition

For those who want a little more, there's the iMac DV Special Edition. It includes all the great features of the iMac DV models and it comes in a see-through graphite color. Plus, it has twice the standard RAM and a larger hard drive than the iMac DV models.

- 128MB of SDRAM; two SODIMM slots support up to 512MB
- Internal 13GB Ultra ATA hard disk drive

only \$1,494 #56406 (Graphite)

Lease for \$60/mo.

Protect your investment with a New  
AppleCare Warranty from MacMall!



**macmall.com**  
Mention your Priority Code: #ZMWD043

or AOL Keyword:  
**MacMall**



Be the  
first to get  
the latest  
products!

Visit [macmall.com](http://macmall.com)  
or call for details.



Norton AntiVirus 6.0

only \$4<sup>99</sup> #48587  
Price after mail-in rebate when  
you buy w/MacInTax Deluxe.

3 Piece  
Speaker Set

only \$69<sup>99</sup> #52911



USB Twin Serial  
Adapter

only \$79<sup>99</sup> #47509

NEW! ScanMaker  
V6UPL USB Legal Size  
Scanner

only \$139<sup>99</sup> #54867



External USB Floppy  
Drive w/FREE  
Color Kit

only \$89<sup>99</sup> #54835

iSweetNet USB  
Scrolling Mouse

only \$29<sup>99</sup> #54919



**VIKING**  
COMPONENTS Don't Forget  
the Memory!

#42223	32MB PC100 DIMM	\$119 <sup>99</sup>
#42224	64MB PC100 DIMM	\$176 <sup>99</sup>
#42225	128MB PC100 DIMM	\$365 <sup>99</sup>
#42226	256MB PC100 DIMM	\$679 <sup>99</sup>

Have your RAM professionally installed by one of our factory-trained technicians for only \$30. Ask for #2214. For more Viking memory call or visit [macmall.com](http://macmall.com). Prices are valid at time of press and are subject to change due to market fluctuations. Please call for most current pricing.

**MacMall**



# G4s up to 4

**H**ow fast is the new G4? This fast: The PowerPC G4 processor running at 350, 400 or 450MHz

computing technologies like vector processing, data stream prefetching and 128-bit data paths. In fact, the 450MHz G4 is a stunning 2 to 3 faster than PCs based on the fastest Pentium III processor.

So if you like the Pentium-crushing speed and the convention-crushing design, call MacMall today. The new G4 is just what you need for 3D rendering, special lighting effects, advanced voice recognition and digital video production.

## The Fastest Desktop Ever!

### Outrageous power

- PowerPC G4 processor running at 350, 400 or 450MHz
- Velocity Engine vector processing unit
- Full 128-bit internal memory data paths
- Powerful new floating point unit
- Data stream prefetching operations supporting four simultaneous 32-bit data streams
- 1MB of backside level 2 cache running at half the processor speed
- 100MHz system bus
- 64, 128 or 256MB RAM
- Supports up to 1.5GB of high performance PC100 SDRAM

- 10, 20 or 27GB Ultra ATA hard disk
- 32X CD-ROM drive, DVD-ROM drive or DVD-RAM drive
- 100MB Zip drive (some configurations)
- Built-in 10/100BASE-T Ethernet networking; optional Gigabit Ethernet

### Advanced capabilities

- Two or three 400Mbps FireWire ports
- Two USB ports—up to 127 devices at once
- Optional AirPort wireless networking card
- Two additional internal drive bays
- Three 64-bit PCI slots
- Now enhanced for Adobe Photoshop
- Includes Mac OS 9

### Great graphics and video features

- ATI RAGE 128 Graphics Accelerator with 16MB of SDRAM graphics memory
- Support for up to 1,600-by 1,200-pixel resolution at 32 bits per pixel (millions of colors) and up to 85Hz refresh rate
- Hardware acceleration of graphics and video
- Advanced integrated triangle setup engine
- Single-pass multi-texturing design

### Design elegance

- Translucent silver and graphite case
- Easy, drop down accessibility for installing cards, drives, and memory
- Convenient, built-in handles for easy carrying

Call for our full  
line of peripherals,  
**USB**  
UNIVERSAL SERIAL BUS  
Visit [macmall.com](http://macmall.com)



**\$1,594** #56382

G4s starting at only

Call for even lower price!

Or lease for as low as \$64 per month

**NEW G4 Server Series** Monitor sold separately.

Order Any Time! Open 24 Hours!  
Order Today by 10pm EST—  
Get it Tomorrow by 10:30am!

**1-800-217-9492**



# 50MHz!

## MacMall Exclusive! Up to \$250 Cash Back!

Purchase Any Product Over \$799 and Get Instant Cash Back up to \$250!



If Product Price is Between	You Get EXCLUSIVE Cash Savings
\$799-1199	\$25 Gift Cheque
\$1200-1799	\$50 Cash Back
\$1800-2899	\$100 Cash Back
\$2900-3399	\$150 Cash Back
\$3400-4399	\$200 Cash Back
\$4400+	\$250 Cash Back

All offers are subject to change. Limit 1 free offer per customer. Sales tax and shipping do not qualify as part of product price total. Valid only on regular in stock items—special order and clearance items do not apply. Not valid with any other offer.

Call now or visit [macmall.com](http://macmall.com) for details

Limited time offer. Valid until 4/3/00.

## Introducing AirPort™!

Transform your new iBook into a wireless Internet surfing machine!

No more hunting around for a phone jack every time you want to get online—if you're within 150 feet of the AirPort, you're connected! All you need is an AirPort card for your iBook and the AirPort Access Point.

AirPort also lets multiple iBooks access the Internet at the same time, transfer files, and of course, play multi-player network games! Share one Internet account everyone in the family can use at the same time.



#49221	<b>AirPort Hardware Access Point</b>	\$299 <sup>99</sup>
#49222	<b>AirPort Card</b>	\$99 <sup>99</sup>

## New Power Mac G4s!

### Protect Your Investment:

Get a NEW AppleCare Service Plan with your G4!

Order#	#56382	#56384	#56385
MHz	350MHz	400MHz	450MHz
RAM	64MB	128MB	256MB
Hard Drive	10GB	20GB	27GB
Multimedia	DVD-ROM	DVD-ROM	DVD-RAM
Zip Drive	N/A	Yes	Yes
Modem	56K	56K	N/A
Price	<b>\$1,594</b>	<b>\$2,494</b>	<b>\$3,494</b>
Lease Price	\$64/month	\$100/month	\$140/month

Call for Even Lower Prices!

**Build to Order!**

Don't see the configuration you want? Call your MacMall representative to get your Power Mac the way you want it!

**macmall.com**  
Mention your Priority Code: #ZMWD043

or AOL Keyword: **MacMall**



Be the first to get the latest products!

Visit [macmall.com](http://macmall.com) or call for details.



**Astra 4000U**  
1200x2400dpi Scanner

only **\$399<sup>99</sup>** #52476

**Apple 17" Studio Display**

only **\$499<sup>99</sup>** #51582



**Apple 21" Studio Display**

only **\$1,499<sup>99</sup>** #51583

**DCR-TRV900 3 CCD Digital Camcorder**

Call for Price!  
#37986 See our Consumer Electronics



**Adobe Photoshop 5.5 Upgrade**

only **\$114<sup>99</sup>** #47478  
Price reflects \$70 mfr. mail-in rebate for Photoshop 5.0 and ImageReady 1.0 owners. Reg. price \$184.99.



**HP LaserJet 4050 USB Mac Laser Printer**

only **\$1199<sup>99</sup>** #56279



**VIKING COMPONENTS**

Don't Forget the Memory!

#42223	32MB PC100 DIMM	\$119 <sup>99</sup>
#42224	64MB PC100 DIMM	\$176 <sup>99</sup>
#42225	128MB PC100 DIMM	\$365 <sup>99</sup>
#42226	256MB PC100 DIMM	\$679 <sup>99</sup>

Have your RAM professionally installed by one of our factory-trained technicians for only \$30. Ask for #2214. For more Viking memory call or visit [macmall.com](http://macmall.com). Prices are valid at time of press and are subject to change due to market fluctuations. Please call for most current pricing.

**MacMall**



# Faster PowerBook G3's!

## Apple® G3 PowerBook® up to an incredible 400MHz!

The Apple® G3 PowerBooks® series is the sleekest, fastest, best-equipped notebooks ever! With

the high-performance G3 processor under the hood, they out-perform comparable Pentium and Pentium II

processor-based desktop systems, with go-anywhere, do-anything PowerBook convenience!

### Processor and Memory

- 333 or 400MHz PowerPC G3 processor
- 512K or 1MB backside Level 2 Cache; 133 or 160MHz dedicated 64-bit backside bus
- Integrated floating point unit and 64K on-chip Level 1 cache (32K for data and 32K for instruction)
- 64MB RAM; 2 SO-DIMM slots support up to 384MB RAM

### Storage

- Internal 4 or 6GB IDE hard drive
- 24X CD-ROM (#56386) or DVD-ROM drive (#56387) for use in expansion bay
- Removable 1.44MB floppy disk drive for use in expansion bay (sold separately)
- Hot-swappable expansion bay supports CD-ROM, DVD, Zip, SuperDisk or hard drive

### Expansion & Networking Ports

- 2 USB ports, SCSI port, power adapter port
- Built-in 10/100BASE-T Ethernet
- RJ-11 modem port, 4Mbps Infrared (IrDA) port
- Support for a Zoom Video PC card
- PC Card Slot for one Type I or Type II card

### Graphics, Video & Sound

- 14.1 inch (diagonal) display features built-in TFT XGA active matrix display, supporting millions of colors at 1024 x 768 resolution
- 8MB SDRAM video memory
- 2D/3D graphics, through integrated ATI RAGE LT Pro video controller
- S-Video port
- 16-bit CD quality stereo input/output
- 24-bit video output port (VGA-style connector)
- Two built-in stereo speakers
- Internal omnidirectional microphone

### Portability

- Includes one Lithium-ion battery for up to 5 hours of normal use; supports two batteries for as much as 10 hours of use (depending on configuration and usage)

### Size and Weight

- Width: 10.4"; Height: 12.7"; Depth: 1.7" long; Weight: 5.9lbs. (w/CD-ROM + battery installed)



## USB PowerBook G3 Series!



Order	MHz	RAM	HD	Cache	Drive	Modem	Display	Price	Lease
#56386	333	64MB	4GB	512K	24X CD-ROM	56K	14.1" Active Matrix	\$2,494	\$100
#56387	400	64MB	6GB	1MB	DVD-ROM	56K	14.1" Active Matrix	\$3,494	\$140

### Build To Order!

Don't see the configuration you want? Call your MacMall Account Executive to get a PowerBook the way you want it!

### Apple Add-Ons

#31413	Apple AC Adapter	\$94 <sup>99</sup>
#47086	Apple Lithium-Ion Rechargeable Battery	\$149 <sup>99</sup>

Order Any Time! Open 24 Hours!  
Order Today by 10 pm EST—  
Get it Tomorrow by 10:30 am!

# 1-800-217-9492



# iBook

## The Portable iMac!



### Outrageous performance.

- PowerPC G3 processor running at 300MHz
- 512K backside level 2 cache on processor
- 32MB of SDRAM; supports to 160MB RAM
- 3.2GB IDE hard disk drive
- Built in 24X CD-ROM drive

### Connectivity.

- One 12-Mbps Universal Serial Bus (USB) port
- Built-in 10/100BASE-T Ethernet
- Built-in 56K modem
- Optional AirPort wireless networking card

### Great graphics and video features.

- ATI RAGE Mobility graphics controller with 2X AGP
- 4MB SDRAM video memory
- 12.1-inch (diagonal) built-in TFT SVGA active-matrix display
- 800 x 600 resolution with single built-in speaker
- 13.5" x 11.6" x 1.8" average; depth ranges from 1.24" to 2.06"
- 6.6 pounds

### Cool software.

- Mac OS
- Microsoft Internet Explorer
- AppleWorks
- World Book Encyclopedia
- Nanosaur and Bugdom 3D games



only  
**\$1,594**

Or lease for \$64/mo.

- #56389 Blueberry
- #56391 Tangerine

Protect your investment with a New AppleCare Warranty from MacMall!

**Save \$\$\$**  
Call for Even Lower Price or Visit [macmall.com](http://macmall.com)!

# 300MHz

## MacMall Exclusive! Up to \$250 Cash Back!

Purchase Any Product Over \$799 and Get Instant Cash Back up to \$250!



If Product Price is Between	You Get EXCLUSIVE Cash Savings
\$799-1199	\$25 Gift Cheque
\$1200-1799	\$50 Cash Back
\$1800-2899	\$100 Cash Back
\$2900-3399	\$150 Cash Back
\$3400-4399	\$200 Cash Back
\$4400+	\$250 Cash Back

All offers are subject to change. Limit 1 free offer per customer. Sales tax and shipping do not qualify as part of product price total. Valid only on regular in stock items—special order and clearance items do not apply. Not valid with any other offer.

Call now or visit [macmall.com](http://macmall.com) for details

Limited time offer. Valid until 4/3/00.

**macmall.com**  
Mention your Priority Code: #ZIMWDD43

or AOL Keyword: MacMall



Be the first to get the latest products!

Visit [macmall.com](http://macmall.com) or call for details.

**Microsoft Word 98 Special Edition**  
only **\$86<sup>99</sup>**  
After \$30 mfr. mail-in rebate  
#49052

**Connectix RAM Doubler 9**  
only **\$44<sup>89</sup>**  
#54716

**4 Port USB Mini Hub for Laptops**  
only **\$29<sup>99</sup>**  
#47702

**Zip Drive for New 1999 PowerBook G3**  
only **\$217<sup>99</sup>**  
#47081

**Nikon Coolpix 950**  
only **\$795<sup>99</sup>**  
#43893

**PowerLite 500c Portable Projector**  
only **\$4124<sup>99</sup>**  
#55449

**VIKING COMPONENTS**  
Upgrades for your PowerBook G3!

#31440	64MB PowerBook G3	\$211 <sup>99</sup>
#31442	128MB PowerBook G3	\$401 <sup>99</sup>
#41979	128MB Low Profile	\$373 <sup>99</sup>
#41978	256MB Low Profile	\$744 <sup>99</sup>

Have your RAM professionally installed by one of our factory-trained technicians for only \$20. Ask for #2214. Visit our Web site: [macmall.com](http://macmall.com) for more Viking memory. Prices are valid at time of press & are subject to change due to market fluctuations. Please call for most current pricing.

# MacMall



# If You Don't See it,

## MacMall has the best prices on USB peripherals for the iMac™, iBook™, PowerBook G3, Power Mac G3 and G4!

**Stylus® Color 740i Printer**  
The awesome Inkjet in iMac and iBook Custom Colors  
**\$129<sup>99</sup>\***

#54219  
\*Reg. price \$179<sup>99</sup> - \$50 mail-in rebate. Expires 3/30/00. Factory refurbished.



EPSON

**NEW! EPL 5700i USB Laser Printer**  
The first laser printer designed especially for iMac, G3 and G4.  
**\$349<sup>99</sup>**

#52174  
Price reflects \$50 coupon in box mfr. mail-in rebate. Regular price \$399.99 - \$50 Rebate = \$349.99



EPSON

**Stylus Scan 2000 All-in-One Printer/Scanner/Copier**  
Up to 1440 x 720 dpi  
6 ppm black, 5 ppm color  
36-bit color depth  
**\$299<sup>99</sup>**

#51645

\$50 Price drop!



EPSON

**HP DeskJet 832C USB Printer**  
Match your iMac and iBook with Optional Colored Covers!  
**\$179<sup>99</sup>**

#49550

\$50 Rebate w/CPU Purchase!



hp

**4 Port USB Hub**  
Provides instant expandability that is as simple as plugging in a USB connector!  
**\$24<sup>99</sup>**

#48810



BELKIN

**WACOM Candy-Colored 4" x 5" USB Graphire Tablets**  
Includes cordless mouse and pressure sensitive pen  
**\$99<sup>99</sup>**

#56037 (blueberry)

Now in all 5 iMac Flavors!



WACOM

**Que! 4x4x8 CD-RW Drive**  
The revolutionary USB interface CD-RW drive allows iMac users to easily record, erase and rewrite CD's again and again at 4X Write and 4X Rewrite speeds.  
Includes a FREE Carrying Case!  
**\$319<sup>99</sup>**

#56374



Que!

**UMAX Astra 4000U USB Scanner**  
42-bit resolution > 1200 x 1200dpi  
Legal size scan area > Includes: Adobe Photoshop LE, VistaScan 3.5, Caere OmniPage LE and more  
was \$499<sup>99</sup> Now Only  
**\$399<sup>99</sup>**

#52476



UMAX

**NEW! USB BusStation™**  
Create your own custom configured USB multi-function hub. Comes standard with 7-port hub, interchangeable with other USB modules.  
**\$99<sup>99</sup>**

#54093



BELKIN

**Kodak DC240i Digital Camera**  
Available in five iMac colors! Includes 8MB Picture Card. Serial & USB Compatible.  
**\$549<sup>99</sup>**

#54131 Blueberry  
Call for compatibility update.



Kodak

**iREZ Kritter USB Camera**  
**\$129<sup>99</sup>**

#56642



iREZ

**NEW! ScanMaker V6 UPL USB Legal-Size Scanner**  
Includes a bonus 35mm scanning accessory and features ScanWizard 5 controller software and a GO button on the scanner.  
**\$139<sup>99</sup>**

#54867



MICROTEK

**2.2GB ORB External Drive**  
The First High Capacity USB Removable Hard Drive!  
**\$279<sup>99</sup>**

#44416



CASTLEWOOD

**New! Zip 250MB USB Zip® Drive!**  
It's small, sleek and portable.  
Hot swappable USB  
Uses both 100MB and 250MB Zip disks  
**\$179<sup>99</sup>**

#52012



Zip

**NEW! External USB Floppy Drive with Color Panels**  
Hot swappable USB interface; no AC adapter required  
**\$89<sup>99</sup>**

#54835



VST

**SuperDisk Drive!**  
Twice as fast! Reads & writes both 120MB SuperDisk diskettes and standard HD 3.5" diskettes.  
now only  
**\$149<sup>99</sup>**

#46876



IMATION

### Great peripheral deals for your serial and SCSI Macs!

**NEW! Palm VII Organizer!**  
Wireless Internet Access with MacPac  
**\$449<sup>99</sup>**

#56396

New Low Prices on Palm IIIx, V & Vx



PALM COMMUNICATIONS PLATFORM

**NEW LOW PRICE!**  
**La Cie External 12x4x32 SCSI CD-RW Drive!**  
Create your own music or data CDs.  
12X record speed  
2MB data buffer  
**\$419<sup>99</sup>**

#54003



LACIE

**HP LaserJet 2100M Printer factory refurbished!**  
True 1200 x 1200 dots per inch offers exceptional detail  
10 pages per minute  
HP PCL 6 w/HP PostScript Level II emulation  
**\$549<sup>99</sup>**

#53920

SAVE \$230!



hp

**Exclusive Offer!**  
**Stylus Photo 700 Color Printer!**  
Serial interface; Optional USB adapter available (#34858)  
**\$99<sup>99</sup>**

#52690

\$50 Mail-in Rebate w/Color Cartridges purchase.

when you purchase 1 or more black and color ink cartridges. Reg. Price is \$129.99. Factory refurbished. While supplies last



EPSON

**Exclusive Offer!**  
**PowerLook II Scanner with Transparency Adapter**  
High-end scanning at an incredible price; 36-bit color; 600 X 1200dpi; SCSI 2  
**\$399<sup>99</sup>**

#56326

Factory refurbished, 90-day warranty.

While Supplies Last!



UMAX

Order Any Time! Open 24 Hours!  
Order Today by 10 pm EST—  
Get it Tomorrow by 10:30 am!

# 1-800-217-9492



# Call Us!

# Be the First to get the Latest Products!



**TechTool Pro**  
The best utility to repair your Mac!  
➤ Recover lost data  
➤ Preview problems before repairing  
➤ OS 9 compatible

**only \$89<sup>89</sup>**  
#30489

No other program tests as many different aspects of your system as thoroughly as TechTool Pro.

**MacInTax Deluxe 99**  
The #1 tax software now includes **FREE** MacInTax State! Buy both MacInTax Deluxe and State, and redeem the purchase price of MacInTax State via mfr. mail-in rebate in box.

**only \$49<sup>95</sup>** #52757  
#52944 MacInTax State CA \$27<sup>95</sup>  
#52947 MacInTax 32 Multi-State \$27<sup>95</sup>

**MAC OS 9**  
New! Exclusive access to Apple's iTools available to Mac OS 9 users.  
**\$68<sup>99</sup>**  
#49794  
After \$20 mfr. mail-in upgrade rebate for owners of Mac OS 8.5 or 8.6.

Mac OS 9 is the ultimate upgrade for anyone on the Internet and those who want to be!

Authorized Catalog Reseller

Call us or visit [macmall.com](http://macmall.com) for details.

**macromedia**  
add life to the web

**New FreeHand 9 and Flash Studio**

**FreeHand 9 and Flash Studio Upgrade** Power Mac  
**only \$189<sup>99</sup>**  
#56670

**FreeHand 9**—The Professional Illustration and Layout Solution for Print & Web!

**Flash 4**—Produce Suites with Full Design Fidelity!

#56668 FreeHand 9 & Flash Studio Full Version	\$479 <sup>99</sup>
#48208 FreeHand 9 Upgrade	\$139 <sup>99</sup>
#48080 FreeHand 9 Full Version	\$379 <sup>99</sup>
#46851 Flash 4 Upgrade	\$119 <sup>99</sup>
#46850 Flash 4 Full Version	\$278 <sup>99</sup>

**Adobe Web Collection**  
Industrial strength Web publishing in one integrated suite.  
**Save over \$250!**  
**only \$989<sup>99</sup>**  
#48276  
Includes:  
Adobe GoLive 4.0  
Adobe Photoshop 5.5  
Adobe Illustrator 8.0

**Save \$20 when You Buy Norton AntiVirus 6.0 with MacInTax Deluxe!**  
**Norton AntiVirus 6.0**  
**SYMANTEC \$24<sup>99</sup>** #48587  
\*Price after \$40 upgrade/crossgrade/competitive upgrade rebate for users of NUM, NAV, VirusScan and Virex. And an additional \$20 cash back (via mfr. mail-in rebate when you buy NAV 6.0 with MacInTax Deluxe. Offer valid 12/4/99-4/15/00. Coupon must be redeemed by 5/15/00.

**Triple Your System Memory!**  
**RAM Doubler 9**  
Run more applications!  
**\$44<sup>89</sup>**  
#54716  
Updated for compatibility with Mac OS 9.

**Connectix**

The #1 choice for boosting your RAM.

**IntelliNews**  
Get the News, weather, sports and more, delivered right to your desktop. Updates every 15 seconds. Stay informed with IntelliNews!

**only \$19<sup>99</sup>**  
#56502  
Get up-to-the-minute sports scores, stock quotes, weather reports and more!

**Aladdin Systems**

**ViaVoice Millennium Edition 1.1**  
The first continuous speech recognition software for the Mac!  
**\$74<sup>99</sup>**  
#53629  
Control your Mac with your voice!

**IBM**

**Stuffit Deluxe 5.5**  
Stuffit Deluxe 5.5 provides up to 20% better compression to make files smaller for faster Internet transfers and increased hard disk space.  
**only \$14<sup>99\*</sup>**  
#52764  
\*Price reflects \$60 mail-in upgrade rebate for Stuffit and DropStuff owners. \$30 mail-in rebate for new users.

**Aladdin Systems**

We do our best to be accurate, but occasionally mistakes occur. We are not responsible for any typographical, photographic or technical errors. Products and packaging may differ from stock available at time of shipment; we reserve the right to substitute equivalent items.

**1000'S OF OUR MOST POPULAR GAMES!**

<b>Rainbow Six</b> \$44 <sup>89</sup> #52640	<b>Quake Arena III</b> \$49 <sup>89</sup> #52452	<b>Baldur's Gate</b> \$42 <sup>99</sup> #51847	<b>Nightfall</b> \$19 <sup>99</sup> #45562
<b>Madden NFL 2000</b> \$43 <sup>99</sup> #51845	<b>Star Wars Racer</b> \$39 <sup>89</sup> #52621	<b>Unreal Tournament</b> \$45 <sup>99</sup> #813606	<b>Sid Meier's Alpha Centauri</b> \$44 <sup>89</sup> #53778

**Introducing the Mac Software & Accessories Buyers Guide!**

**Call For Yours Today!**  
**1-888-425-MALL**  
Visit Our Online Catalog at [software.macmall.com](http://software.macmall.com)

**macmall.com** or AOL Keyword: MacMall  
Mention your Priority Code: #ZMWD043

**MacMall**



# iMac G3 G4 iBook

## All custom configured for you.



Get your  
Macintosh built  
the way  
you want it.

CDW will custom configure your system to fit your needs and, in most cases, ship it the same day. Call your CDW account manager today and build the Mac of your dreams.

### Experience digital video

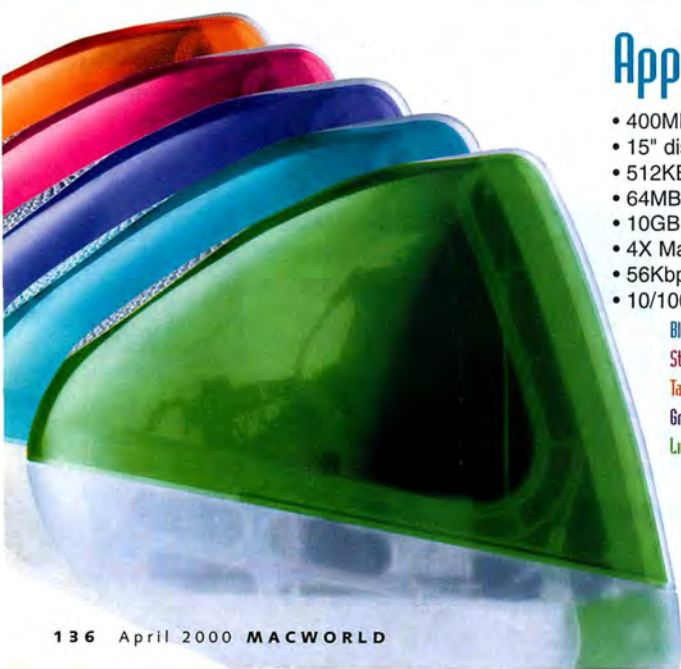

### Apple® iMac™ DV

- 400MHz PowerPC G3 processor
- 15" display, 13.8" viewable image size
- 512KB backside Level 2 cache
- 64MB SDRAM
- 10GB hard drive
- 4X Max DVD-ROM drive
- 56Kbps (V.90) modem
- 10/100BASE-T Ethernet

Blueberry	CDW 190108
Strawberry	CDW 190120
Tangerine	CDW 190110
Grape	CDW 190114
Lime	CDW 190123

**\$1294**



### iMac DV Graphite

**Special features include:**

- 400MHz PowerPC G3 processor
- 128MB SDRAM
- 13GB hard drive

CDW 190128

**\$1494**





# Consider the possibilities

CDW carries the full line of Macintosh and Macintosh compatible products. Call your CDW account manager or visit us at [www.cdw.com](http://www.cdw.com) for more information.



## Apple® Power Macintosh G4 Series

- 350MHz PowerPC G4 processor
- 1MB backside cache
- 100MHz system bus
- 64MB SDRAM
- 10GB hard drive
- DVD-ROM drive
- 56Kbps (V.90) modem

**\$1594**

CDW 197081

- 400MHz PowerPC G4 processor
- 1MB backside cache
- 100MHz system bus
- 128MB SDRAM
- 20GB hard drive
- DVD-ROM drive
- 100MB Zip drive
- 56Kbps (V.90) modem

**\$2494**

CDW 196897

- 450MHz PowerPC G4 processor
- 1MB backside cache
- 100MHz system bus
- 256MB SDRAM
- 27GB hard drive
- DVD-RAM drive
- 100MB Zip drive
- 56Kbps (V.90) modem

**\$3494**

CDW 197152



## Apple® iBook™

- 300MHz PowerPC G3 processor
- 512KB backside Level 2 cache
- 32MB RAM • 3.2GB hard drive
- 24X Max CD-ROM drive • 56Kbps (V.90) modem • 10/100BASE-TX Ethernet • 12.1" active-matrix SVGA display

**\$1596**

Tangerine CDW 179139  
Blueberry CDW 179140



## Adobe® Publishing Collection

Includes: PageMaker® V6.5 Plus, Photoshop® V5.5, Illustrator® V8.0 and Acrobat® V4.0

**\$997.64**

CDW 174166



## ViewSonic® E711 monitor

17" flat square CRT display, 16" viewable image size

**\$229.56**

CDW 98516



## Lexmark® Optra M410

Laser printer

- Resolution: 1200 Image Quality mode\*
- Print speed: 12 ppm
- Adobe® PostScript® Level 3
- USB and parallel connectivity
- 1-year LexExpress warranty

**\$668.23**

CDW 187043

\*1200 Image Quality simulates 1200 dpi. Specifications are 600 dpi, however, the intensity of the dot appears more than 600 dpi. The advantage of 1200 dpi Image Quality is also engine speed.

## QuarkXPress V4.1

QuarkXPress V4.1 is more than just page layout software. It lets you combine pictures, text, typography, writing, editing and printing—in one application. What's more, this program gives you total command over page layout.

**\$796.14** CDW 198618

Coming soon! Reserve your copy now!

Coming soon!

## Lucent WaveLAN IEEE Turbo Wireless Silver 11Mb PC Card

**\$169.33** CDW 193484

**NEW!**



**LEXMARK** Lucent Technologies  
Full-Label Innovation



**QUARK**



Computing Solutions  
Built for Business™

[www.cdw.com](http://www.cdw.com)  
800-509-4239

BUY WITH CONFIDENCE CDW IS A NASDAQ TRADED COMPANY TICKER SYMBOL CDWC  
D & B rated SA1 Duns 10-762-7952

MasterCard VISA NOVUS Credit card charges are not submitted until time of shipment. For your protection, we ship only to your credit card's verified billing address. Shipping and handling charges apply; please ask your CDW account manager for details. Before returning any product, you must obtain an RMA number. Non-defective returns are subject to a restocking fee. Software, chips and other electronic components are not returnable. Allow 10 business days for shipping when paying by personal check. All pricing subject to change. For all prices, products and offers, CDW reserves the right to make adjustments due to changing market conditions.

product discontinuation, manufacturer price changes, errors in advertisements or other extenuating circumstances. All trademarks and registered trademarks are the sole property of their respective owners. All products sold by CDW are third party products and are subject to the warranties and representations of the applicable manufacturers, including but not limited to Y2K compliance. Accordingly, CDW makes no representation or warranty with respect to the Y2K compliance of products sold. 56K modems are capable of 56Kbps downloads, however, current regulations limit download speed to 53Kbps. Internet connectivity requires access services from an Internet access provider. Contact your local access provider for rates, terms and conditions.

©2000 CDW® Computer Centers, Inc. 200 N. Milwaukee Avenue, Vernon Hills, IL 60061 MW5455AB 4/00



## Compatibility at an unbelievable price



**USB CD-RW**  
**\$279.95**

APS Pro2

### APS USB CD-RW 4x4x24

- CD-RW drive with convenient USB interface for hot-swapping, long chains
- Excellent for iMacs, newer G4 Macs and PCs



This CD-ReWritable drive hooks up in a flash to your USB-compatible PC or Mac. And since USB is hot-swappable, you can share the USB CD-RW with other compatible systems in no time flat. There has never been a USB CD-RW drive like this. Call and order today.



**APS CD-RW**  
**\$299.95**

APS Pro2

### APS CD-RW 8x4x24 SCSI

- Our newest rewritable CD drive is second-fastest ever
- Burn a CD in just nine minutes, rewrite in 18



The newest member of the APS CD-RW family boasts blazing speed and great value. The 8x4x24 mechanism comes from Yamaha, an industry leader in CD performance and reliability. And in the new APS Pro2 enclosure, this drive is protected from failed burns and overheating.

### APS CD-RW 12x4x32 SCSI

**\$369.95** APS Pro2



**\$499.95**

APS Pro

### APS DVD-RAM 5GB

- Rewritable DVD discs with 5.2GB of storage for backup, archiving or digital video storage
- Also reads virtually any CD at up to 20X speed

**Introducing data storage for the new millennium**



**\$469.95**

APS Pro 2

### APS FireWire 20GB Hard Drive

- Easiest connections ever – hot-swappable, no terminator, no device ID
- Up to 63 FireWire devices on one bus
- Ideal for personal video storage and editing, large-scale imaging/graphics

#### USB and FireWire Drives

APS USB CD-RW 4x4x24	\$279.95
APS CD-RW 8x4x32 FireWire	399.95
APS 13GB USB Hard Drive	259.95
APS 20GB USB Hard Drive	369.95
APS 20GB FireWire Hard Drive	469.95
APS 37GB FireWire Hard Drive	649.95

#### APS Ultra 2 Wide/Ultra 160 LVD SCSI Drives

Model	RPM	Bare	APS Pro
APS 1 9GB Ultra 2 LVD	7200	\$269.95	\$339.95
APS ST 9GB Ultra 2 LVD	7200	299.95	369.95
APS 1 9.1GB Ultra 2 LVD	10000	429.95	499.95
APS ST 9.1GB Ultra 2 LVD	10000	419.95	489.95
APS 1 18GB Ultra 2 LVD	7200	459.95	529.95
APS ST 18GB Ultra 2 LVD	7200	459.95	529.95
APS 1 18GB Ultra 2 LVD	10000	689.95	759.95
APS ST 18GB Ultra 2 LVD	10000	659.95	729.95
APS ST 36GB Ultra 2 LVD	10000	1,069.95	1,139.95
APS ST 50GB Ultra 2 LVD	7200	949.95	1,019.95

Drives listed above carry a five-year warranty.

\* Bare configuration does not include a mounting bracket. Intended as a replacement internal SCSI drive.

### APS 50GB LVD Ultra 2 Wide SCSI

- 7200 rpm drives offer reliability, performance
- 50GB for your most data-intensive creations



**50GB LVD**  
**\$949.95**

Internal Configuration

#### ~ CLOSEOUT SALE ~

APS CD-R 4x16 / 6GB Mastering System	\$499.95
APS 16x 5-Disc CD-ROM Changer	199.95
APS 1GB Jaz Cartridge Mac	69.95
APS Pro Enclosure (Closed Front Narrow)	49.95
APS Pro Enclosure (Closed Front Ultra Wide)	49.95
APS Q 8GB Int. Ultra SCSI 5400 rpm Refurb.	199.95
APS JAZ II / 4x12x16 Mastering System	599.95
APS DLT Autoloader 4500 Rack Mount	2,599.95

**While Supplies Last**

## Ultra SCSI drive ultra-low price



**\$299.95**

APS Pro

### APS ST 9GB Ultra SCSI

- Medalist Pro mechanism
- Perfect for design/publishing with an ultra low price



#### APS Ultra SCSI Drives

MODEL	RPM	* BARE	APS PRO
APS ST 4GB	7200	\$199.95	\$269.95
APS ST 9GB	7200	299.95	299.95
APS 1 18GB	7200	459.95	529.95

Drives listed above carry a three-year warranty.

#### APS IDE Ultra ATA/66 Drives

MODEL	RPM	INTERNAL
APS 13GB IDE	7200	\$149.95
APS 20GB IDE	7200	189.95
APS 37GB IDE	5400	349.95

Drives listed above carry a one-year warranty

\* Bare configuration does not include a mounting bracket. Intended as a replacement internal SCSI drive.



Drives on these pages are covered by the APS 30-Day Money-Back Guarantee.

<http://www.apstech.com>  
For up-to-the-minute pricing



# TO SPEED?

**Saves more than  
just your data**

## APS HyperDAT® II

- Inexpensive yet powerful desktop backup
- Protects up to 4GB (native) per tape at up to 46MB/minute (no hardware compression)

 If you run a fast-paced small business, or you oversee busy corporate workstations, the HyperDAT II cuts your backup times by 64%. The APS HyperDAT II can also use your existing DDS-1 tapes. Limited three-year warranty for super value.

**APS TECH exclusive!**  
Now each tape drive includes both  
**MAC and PC Retrospect software.**



**\$599.95**

APS Pro Case w/Retrospect Software for MAC and PC



## Sony DSC-F505

- 2.1 Megapixel capture
- Super HAD CCD Imager
- Carl Zeiss Optics

**\$999.95**

### Displays

Sony Monitors	
F-Series Monitor 19" Sony GDM-F400	\$929.95
F-Series Monitor 21" Sony GDM-F500	1,759.95
G-Series Monitor 19" Sony CPD-G400	649.95
G-Series Monitor 21" Sony CPD-G500	1,199.95

LaCie Monitors	
LaCie electron19blue	\$669.95
LaCie electron22blue	1,299.95

Sony LCD Displays	
Sony Multiscan SDM-N50	\$1,499.95
Sony Multiscan CPD-L133	899.95
Sony Multiscan CPD-L150	1,249.95
Sony Multiscan CPD-L181	3,299.95

## Canon ELURA DV Camcorder

- Palm-sized w/12x optical/48x digital zoom lens
- Better video quality than analog camcorders, VCRs
- Easiest way to grab and produce video



**CALL FOR MOST CURRENT PRICE**

**24 HRS/7 DAYS A WEEK**

**Improve your  
vision**



## LaCie electron19blue

- 19" Natural Flat Diamondtron® CRT
- Award-winning, professional color

**\$669.95**

Includes  
Blue Hood

### Digital Cameras

Sony Digital Cybershot DSC-F505	\$999.95
Sony Digital Cybershot DSC-D770	1,899.95
Sony Digital Mavica MVC-FD83	699.95
Sony Digital Mavica MVC-FD88	899.95
Sony Digital Mavica MVC-FD91	947.95
Olympus C-2020 Zoom	879.95
Olympus C-2500L	1,499.95
Olympus D-620L	999.95
Nikon Coolpix 800	599.95
Nikon Coolpix 950	929.95
Epson PhotoPC 800	679.95
Epson PhotoPC 750z	559.95

### Digital Video Camcorders

Canon ULTURA	CALL
Canon ELURA	CALL
Canon XL-1	CALL
Canon GL-1	CALL

### APS Tape Backup

APS NS-8 (Travan NS-8) SCSI	\$399.95
APS NS-20 (Travan NS-20) SCSI	499.95
APS HyperDAT® II (DDS-2) SCSI	599.95
APS HyperDAT® III (DDS-3) SCSI	849.95
APS HyperDAT® IV (DDS-4) LVD	1,199.95
APS DLT4000 SCSI	1,849.95
APS DLT8000 LVD	4,399.95
APS AIT PLUS Ultra Wide	1,899.95
APS AIT II LVD	3,799.95
APS AIT Plus Autoloader Ultra Wide	3,799.95
APS DDS-3 Autoloader SCSI	2,999.95

Ships with Retrospect software for MAC and PC

### Printers / Scanners

Printers	
Epson Stylus Color 900 Printer	\$399.95
Epson Stylus Photo 1200 USB Color Printer	499.95
Epson Stylus Color 1520 Printer	499.95
Epson Stylus Color 3000 (Mac & PC)	1,249.95
Epson Stylus Pro 5000 Color Printer	2,999.95

Scanners	
AGFA Duoscan Solo	\$2,459.95
Nikon Coolscan III (LS-30) (MAC)	979.95
Nikon Coolscan III (LS-30) (PC)	979.95
Nikon Coolscan 2000 (LS-2000)	1,795.95
UMAX Astra MX3 Flatbed Scanner	199.95
UMAX Astra 2400S Flatbed Scanner	\$299.95
UMAX PowerLook III w/ Trans. Adapter	1,199.95
UMAX Mirage II Flatbed Scanner	1,999.95

### Power Management

APC Surge Station Pro 8	\$32.95
APC Surge Station Pro 8 w/2 Tel	37.95
APC Net 8 Surge Station	33.95
APC Net 8 Surge Station w/Net P	47.95
APC Line Conditioner, R-1250 APC	129.95
APC Line Conditioner, R-600 APC	99.95
APC BackUPS Pro 2805 APC	134.95
APC BackUPS Pro 4205 APC	219.95
APC BackUPS Pro 6505 APC	269.95
APC BackUPS Pro 10005 APC	365.95
APC BackUPS Pro 14005 APC	459.95

Mac OS is a registered trademark of Apple Computer, Inc. APS and APS Technologies are registered trademarks. Other brand or product names are registered trademarks or trademarks of their respective holders.

- 30-day money-back satisfaction on all APS brand drives and accessories. Your risk is the cost of shipping.
- Monitors and 3rd party products carry warranties from their respective manufacturers.
- SCSI cables sold separately.
- APS warranty is a pass-through of the mechanism manufacturer's warranty which will be serviced by APS for one year. APS warrants APS branded enclosures, brackets and power supplies for a period of one year from the date of purchase and will, at its discretion, replace or repair products found to be defective according to the specific terms of the warranty accompanying the product.
- Refused orders subject to 20% restocking fee.

- International customers must pay for all shipping charges.
- Prices and specifications are subject to change without notice.
- Not responsible for typographical errors.
- Your APS drive unit may contain one or more components that were in prior use, but which have been inspected and repaired or rebuilt as necessary. These components, if any are covered by the same warranty provisions, exclusions and limitations to the same extent, and on the same terms as otherwise "new" components.
- © 2000, APS Tech. All Rights Reserved.



Advanced tools for digital visionaries™



Corporate Sales (800) 554-3941 International (816) 920-4109

**Call 800-443-4699**



### VST Technologies



**VST FW1260**  
6GB FireWire Hard Drive

- For FireWire equipped computers •Super-fast, large capacity in a compact design •Portable & easy to use

**\$399<sup>99</sup>** (VST FW1260)

8GB FireWire HD (VST FW1280) **\$499.99**  
10GB FireWire HD (VST FW1210) **\$599.99**  
14GB FireWire HD (VST FW1714) **\$899.99**

Card Bus Card to FireWire Kit •For ANY Card Bus Qualified Laptop (VST FWBC1) **\$149.99**

### Scanners



Other iMac colors available from Canon!

**Canon CanoScan FB630UI**  
USB Flatbed Color Scanner

**\$129<sup>99</sup>** (CAN FB630UI) **NEW!**

Microtek ScanMaker 3600 42-Bit Flatbed Color Scanner (MTX SCANM3600) **NEW!** **\$99.99**

UMAX Astra 2400S Desktop Color Flatbed Scanner (UMX AS12400S00U) **\$299.99**

EPSON Perfection 1200U PHOTO Flatbed Color Scanner (EPS 1200UHPH010) **NEW!** **\$349.99**

Minolta DiMAGE Scan Dual (PC/Mac Film Scanner) (MIN DIMAGE02U) **\$499.99**

### Networking



**MacSense®**  
DSL/Cable Modem Router

- Internet sharing hub for Mac and PC
- Connects up to 252 users to the Internet using one ISP
- DHCP server •Web-based management •Virtual server
- NAT security •4 port 10BASE-T hub

**\$289<sup>99</sup>** (MSN MH120)

**MacSense® 8-Port 10/100Mbps Hub**

- Dual speed fast Ethernet hub •One uplink port •With built-in QuickStack technology for stacking up to 4 hubs
- Uses CAT 5 RJ-45 cabling •Universal power supply

**\$149.99** (MSN FHD60)

### Macintosh® Software



**Corel Draw™ 8.0 for Macintosh**

- The choice of professionals
- Collection of software for illustration, page layout, photo-editing, bitmap creation
- CD-ROM for Power Macintosh

**\$79<sup>99</sup>** REG: \$449.99! SAVE \$370.00! (CM DRAW8-C)

**Suitcase™ (8.0)** by Extensis® (ETM SUITCASE8-C) **\$49.99**

**Toast (4.0) Deluxe** by Adaptec® (ADA TOAST4-C) **\$59.99**

**After \$20 Mail-In Competitive/Upgrade Rebate!**

**RAM Doubler 9 for Macintosh** by Connectix (CNM RAMD9L9-C) **\$44.99**

**WinVoice Millennium** by IBM® (IBN WINVOICE-M) **\$69.99**

**PowerPrint 5.0™ (USB to Parallel)** by Intoflow (IFA PPI5P) **\$89.99**

**FLASH™ 4** by Macromedia® (MMN FLASH4-C) **\$269.99**

# J&R COMPUTER WORLD

## \$400 MAIL-IN REBATE\*

With 3-yr. subscription to CompuServe & purchase of any Computer

1. Purchase any Computer in this ad.
2. Sign up for CompuServe 3.03 for 36 mos. @ \$21.95/mo. (= \$790.20)
3. Save \$400 (By Mail-In Rebate from CompuServe)

Expires March 31, 2000!

## APPLE® POWER MACINTOSH™ G4 COMPUTERS!

**Apple® Power Mac™ G4/350**  
64/10GB/DVD MiniTower

- 350MHz PowerPC™ G4 processor with Velocity Engine™ •64MB SDRAM
- 10GB Ultra ATA/66 hard drive •DVD-ROM with DVD-Video playback
- ATI RAGE 128 Pro graphics card with 16MB memory •56K max. V.90 modem •3 FireWire ports •2 USB ports •10/100BASE-T Ethernet •Mac OS 9 •Monitor sold separately

**\$1599<sup>99</sup>** (APP M7827LL/A) **NEW!**

**Apple® Power Mac™ G4/400**  
128/20GB/DVD/100MB Zip™ Drive MiniTower

- 400MHz PowerPC™ G4 processor with Velocity Engine™ •128MB SDRAM •1MB 200MHz backside level 2 cache •20GB Ultra ATA/66 hard drive •DVD-ROM with DVD-Video playback •56K max. V.90 modem •ATI RAGE 128 Pro graphics card with 16MB memory •3 FireWire ports •2 USB ports •10/100BASE-T Ethernet •Mac OS 9 •Monitor sold separately

**\$2499<sup>99</sup>** (APP M7824LL/B)

**Apple® Power Mac™ G4/450**  
256/27GB/DVD-RAM/100MB Zip™ Drive MiniTower

- 450MHz PowerPC™ G4 processor with Velocity Engine™ •256MB SDRAM •27GB Ultra ATA/66 hard drive •DVD-RAM with DVD-Video playback •ATI RAGE 128 Pro graphics card with 16MB memory •3 FireWire ports •2 USB ports •10/100BASE-T Ethernet •Mac OS 9 •Monitor sold separately

**\$3499<sup>99</sup>** (APP M7825LL/A) **NEW!**

**AppleCare® Protection Plan 3-Year Extended Service Protection Plan For PowerMac® G Series Computers & Apple® Display**

- Display included if purchased at same time as CPU •3 years of phone support (extended from 90 days included with product), 3 years of service coverage (2 years beyond limited warranty), TechTools by Micromat CD & access to 24-hr. Internet support

**\$249.99** (APP M7811L/A)

**\$400 REBATE BONUS!**  
See top of ad for details.

## APPLE® POWER MACINTOSH™ G3 iMac™ COMPUTERS!

**Apple® Power Macintosh® G3/iMac™/350**  
64/6GB/CD All-In-One Computer

- 350MHz PowerPC™ G3 processor •64MB SDRAM •6GB HD •24x max. CD-ROM •ATI RAGE 128 VR 2D/3D with 8MB VRAM •10/100Base-T •56K max. modem •2 USB ports •15" display •Blueberry

**\$999<sup>99</sup>** (APP M7469LL/A)

**Apple® Power Macintosh® G3/iMac™/400**  
64/10GB/DVD All-In-One Computers

- 400MHz PowerPC™ G3 processor •64MB SDRAM •10GB HD •4x max. DVD •ATI RAGE 128 VR 2D/3D with 8MB VRAM •10/100Base-T •56K max. modem •15" display •Blueberry, Tangerine, Grape, Strawberry & Lime

**\$1299<sup>99</sup> EACH!** BLUEBERRY (APP M7493LL/A), TANGERINE (APP M7671LL/A), GRAPE (APP M7672LL/A), STRAWBERRY (APP M7673LL/A) OR LIME (APP M7674LL/A)

**Apple® Power Macintosh® G3/iMac™/400**  
128/13GB/DV Special Edition All-In-One Computer

- 400MHz PowerPC™ G3 processor •512K backside L2 cache •128MB PC100 SDRAM •13GB HD •4x max. DVD-ROM •ATI RAGE 128 VR 2D/3D graphics accelerator with 8MB SDRAM & AGP 2X support •10/100Base-T Ethernet •56K max. fax/data modem •2-FireWire/ 2-USB ports •15" color display (13.8 VIS) •Graphite

**\$1499<sup>99</sup>** (APP M7668LL/A)

**AppleCare® Protection Plan 3-Year Extended Service Protection Plan**

- 3 years of phone support (extended from 90 days included with product), 3 years of service coverage (2 years beyond limited warranty), TechTools by Micromat CD & access to 24-hr. Internet support

**\$199.99** (APP M7812L/A)

**\$400 REBATE BONUS!**  
See top of ad for details.

## APPLE® iBook™ G3 COMPUTERS!

**Apple® iBook™ G3 Notebook Computer**

- 12.1" TFT screen •300MHz PowerPC™ G3 processor •32MB SDRAM •3.2GB HD •24x max. CD-ROM
- Up to 6 hr. battery life/charge •56K max. modem •10/100Mbps Ethernet •USB port

**\$1599<sup>99</sup> EACH!** (APP M7619LL/A) TANGERINE or (APP M7707LL/A) BLUEBERRY

**AppleCare® Protection Plan 3-Year Extended Service Protection Plan**

- 3 years of phone support (extended from 90 days included with product), 3 years of service coverage (2 years beyond limited warranty), TechTools by Micromat CD & access to 24-hr. Internet support

**\$249.99** (APP M7813LL/A)

**\$400 REBATE BONUS!**  
See top of ad for details.

## J&R CORPORATE SALES BUSINESS LEASING:

No Money Down, No Payments for 30 Days!

\*Call J&R Corporate Sales for details at 1-800-221-3191 or 1-212-238-9080



### iMovie

Making movies is as easy as using your iMac.

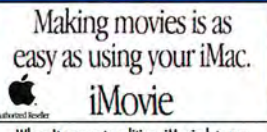

When it comes to editing, iMovie lets you master time & space. It enables you to select your best scenes & present them in the most effective way, without the false starts & miscues that mar most home movies. You decide what's important, & what's not, & you arrange the scenes in the order that works best. The result: home movies that move at the pace of professional productions. With iMovie, you can edit, polish & reorganize your movie — without touching or altering your original DV footage.

### Canon Elura™



**iMovie Compatible!**

**Canon Elura™**  
Digital Camcorder

- Progressive scan CD •12x optical/48x-digital zoom
- 3 shooting modes •2.5" flexible color LCD screen
- Color viewfinder •16:9 wide screen •Remote

**CALL FOR PRICE!** (CAN ELURA)

### Sony DCR-TRV10



**iMovie Compatible!**

**Sony DCR-TRV10**  
Digital Camcorder

- 3.5" SwivelScreen™ precision color LCD monitor
- Memory mode for still image capture onto Memory Stick™ media •Carl Zeiss™ 10x-optical/120x-digital zoom •Color viewfinder
- Super SteadyShot™ •12-bit/16-bit PCM digital stereo audio •NightShot™ system •Photo mode
- LINK™ DV interface •InfoLithium™ battery

**CALL FOR PRICE!** (SON DCRTRV10)

### CD-ReWritable Drives



**QPS Quo! FIRE DRIVE**  
4x4x24x External CD-ReWritable Drive With FireWire™ Interface

- Max: 4x-write/rewrite, 24x read •2MB buffer memory •Up to 6500s data/74 min. audio

**\$299<sup>99</sup>** (QPS RW4424FFMG3)

**QPS Quo! FIRE DRIVE 8x4x32x External CD-ReWritable Drive With FireWire™ Interface** (QPS RW8432FFMG3) **\$399.99**

**Sony Spressa™ CRX100E/X2 4x4x6x External USB Plus CD-RW Drive Upgrade Kit** (SON CRX100E/X2) **\$299.99**

**Smart and Friendly™ Easy Racer RW External CD Recorder With CD-RW ReWritability for iMac™** (SMD SAF747) **\$299.99**

Order from **www.jandr.com**  
AOL keyword: J&R

All Major Credit Cards Accepted  
**Overnight Delivery Available!**

Order Code: **MW004**  
(Prices Good Until 04/15/00)

To Order Toll Free and Receive a Free Catalogue  
**800-221-8180**  
PARK ROW • NEW YORK • NY • 10038 FAX: 1-800-232-4432

Not responsible for typographical or pictorial errors. Merchandise is brand-new, factory-fresh & 100% guaranteed! \*Except where noted, some quantities may be limited.

\*The \$400 mail-in rebate requires: (1) Purchase of a computer; (2) EITHER a contract commitment to a 36 mo. Internet subscription (for \$400 Rebate) to either CompuServe v.3.03 (for Mac) or CompuServe 2000 (for PC) @ \$21.95/mo. Full prepayment of contract amount (\$790.20) is possible during your 1st mo. of service. Both offers also require a completed Mail-In Rebate form & a copy of your dated sales receipt. All of the above must be completed & received by CompuServe within 60 days of purchase. Offer subject to credit approval & your acceptance of CompuServe's Terms of Service. Membership termination prior to contract commitment requires payment of a cancellation fee + rebate repayment according to the following schedule: (1) \$400 Rebate: \$50 cancellation fee plus rebate repayments of \$400 in Mos. 1-12, \$300 in Mos. 13-24, or \$200 in Mos. 25-36. Allow 8-10 weeks from rebate approval for receipt of rebate. Limited time offer for purchases thru 3/31/2000. Valid only in the U.S. to new customers 18 yrs. or older. Limit 1 rebate per eligible computer purchase & per CompuServe account. A major credit card is required for CompuServe 3.03/2000 sign-up, credit approval & rebate repayment & cancellation fees when necessary. Premium services carry surcharges & communications surcharges may apply in AK & outside the U.S. You may incur phone charges, depending on your calling plan & location. CompuServe is a trademark of CompuServe Interactive Services, Inc. Questions, call toll-free 1-800-998-9622 for Mac/1-800-238-0889 for PC. These offers cannot be combined with each other or with any other CompuServe offers.





**FREE SHIPPING FOR ALL ONLINE ORDERS!**

**90 Day Performance Guarantee**

### ACCELERATOR CARD SPECIAL

## Initio Miles UW Card

Only **\$135**

with any new purchase

Supports Ultra2 and UltraWide SCSI peripherals up to 48 MB/sec, and provides enhanced I/O performance for main frame, wide and Ultra SCSI devices.

### dvd-cd-cdr

[www.pdisales.com/merchant/dvd.html](http://www.pdisales.com/merchant/dvd.html)

[www.pdisales.com/merchant/cd.html](http://www.pdisales.com/merchant/cd.html)

### SONY CRX100 FireWire

SONY CRX100 FireWire \$292

CDRW Drive Software Included, 24X/24X External

### Panasonic DVD Ram Drive

Panasonic DVD Ram Drive \$580

External

### SANYO CDR-820

SANYO CDR-820 \$395

CDR Drive External 8X Recorder, 20X Reader, External

### YAMAHA CRW8424

YAMAHA CRW8424 \$399

2Mb Buffer 8X Recorder, 4X ReWritable, 24X Reader, External

### TOSHIBA 40XCD Drive

TOSHIBA 40XCD Drive \$135

XM5911B External

### NEC 24X CD Drive

NEC 24X CD Drive \$93

CRD-1610A External

### memory

[www.pdisales.com/merchant/memory.html](http://www.pdisales.com/merchant/memory.html)

Apple Certified • Highest Quality Memory  
Lifetime Warranty • 24 Hour Replacement

### Blue G3 168 pin SDRAM

32MB • 64MB • 128MB

### Beige G3 168 pin SDRAM

32MB • 64MB • 128MB

### iMac SODIMM

32MB • 64MB • 128MB

### 7200-9600, 5400-6400

168 pin 5vDIMM

16MB • 32MB • 64MB

### accelerator cards

[www.pdisales.com/merchant/SCSI.html](http://www.pdisales.com/merchant/SCSI.html)

### ADAPTEC ADAPTEC

PowerDomain 2940UW UP TO 40 MB/Sec. \$210

Adaptec AHA2930U PCI to Ultra SCSI HD50 pin. \$99

PowerDomain 3940UW PCI \$345

PowerDomain 39160 PCI \$429

Adaptec 29160 PCI Ultra 160 Single Channel \$329

FireWire 8945 PCI \$484

PowerDomain 2940UW Card Only \$222

Adaptec AHA2906 PCI to SCSI 2 HD50 pin. \$53

### ATTO ATTO

Express PCI \$175

Dual Channel Express PCI \$285

Express PCI Ultra2 LVD \$329

Express PCI Ultra2/LVD Dual Channel \$489

### INITIO INITIO

Initio Miles UW \$135

Initio A100U2W PCI to Ultra 2/LVD \$208

UP TO 80 MB/Sec.

### tape backup

[www.pdisales.com/merchant/tape.html](http://www.pdisales.com/merchant/tape.html)

SPEED TUNED TAPE DRIVES IN STOCK TODAY!

#### DAT STORAGE

CAPACITY	MODEL	TRANSFER RATE	SALE
4-8 GB	Sony 7000		742
4-8 GB	HP 1599		791
4-8 GB	Seagate STT28000		330
4-8 GB	Seagate STD28000		577
8 GB	STD28000	60 MB/Min.	595
24 GB	HP 1554		1016
24 GB	Seagate DDS3		824
24 GB	Sony 9000 DDS3	120 MB/Min.	824
40 GB	Seagate DDS4		1184
40 GB	Sony 10000 DDS4	120 MB/Min.	1231
144 GB	HP 1559		2995
192 GB	Sony TSL-9000		824

#### DLT TAPE STORAGE

CAPACITY	MODEL	TRANSFER RATE	SALE
30 GB	DLT2000X1	150 MB/Min.	989
40 GB	DLT4000	180 MB/Min.	1852
70 GB	DLT7000	600 MB/Min.	4121
80 GB	DLT8000	600 MB/Min.	4915

#### AIT STORAGE

CAPACITY	MODEL	TRANSFER RATE	SALE
50 GB	Sony SDX300c	6 MB/Sec.	2330
100 GB	Sony SDX500c	6 MB/Sec.	4054

AIT autoloaders also available... call for details

RETROSPECT 4.0 MAC OR CHEYENNE WINDOWS (NT) SOFTWARE INCLUDED WITH ALL TAPE DRIVES

## speed tuned hard drives

### Seagate CHEETAH

Capacity	Internal	External
9.1GB	\$389	\$469
18.2GB	\$599	\$679
36.4GB	\$1089	\$1169

U2W 10000 rpm 8.2ms Seek (ST39103LW)

LP U2W 10000rpm 1024K 6.9ms 5YR Low Profile (ST318203LW)

U2W 10000 rpm 1024K buffer 6.9ms Seek (ST318403LW)

### Seagate BARRACUDA

Capacity	Internal	External
9.1GB	\$289	\$369
18.2GB	\$439	\$519
36.4GB	\$849	\$929

U2W 7200 rpm (ST39175LW)

LP U2W 7200 rpm 1024K 6.9ms 5YR Low Profile (ST318275LW)

U2W 7200 rpm (ST1158475LW)

U2W 7200 rpm 512K buffer 7.1ms Seek (ST150175LW)

### IBM 7200 RPM ULTRASTAR

Capacity	Internal	External
9.1GB	\$239	\$299
18.2GB	\$449	\$529
36.4GB	\$859	\$939

U2W of Narrow 7200rpm 512K buffer 8.5ms Seek (09150W)

U2W of Narrow 1024K 6.9ms 5YR Low Profile (09ES-31850LW)

U2W or Narrow 7200rpm 4096K buffer 6.8ms Seek

### IBM 10,000 RPM ULTRASTAR

Capacity	Internal	External
9.1GB	\$452	\$532
18.2GB	\$639	\$719
36.4GB	\$1099	\$1179

U2W 10000rpm (93100LW)

U2W 10000rpm 1024K buffer 6.8ms Seek

### Quantum ATLAS 10K

Capacity	Internal	External
9.1GB	\$359	\$439
18.2GB	\$579	\$659
36.4GB	\$1025	\$1105

Ultra2 LVD 10000 rpm (QM335400THLW)

Ultra2 LVD 10000 rpm (QM318200THLW)

Ultra2 LVD 10000 rpm (QM335400THLW)

### Quantum ATLAS IV

Capacity	Internal	External
9.1GB	\$249	\$329
18.2GB	\$395	\$475
36.4GB	\$795	\$875

Ultra2 LVD (QM309100K-LV)

LP Ultra2 LVD (QM318200K-LV)

Ultra2 LVD 7200rpm 1024K buffer 6.9ms Seek (QM335400K-LV)

### IDE hard drives

Capacity	Internal	External
15.2GB	(25L2648)	\$139
20.3GB	(25L2660)	\$197
25.0GB	(25L2652)	\$239
37.5GB	(31L9070)	\$349

### IBM DESKSTAR GXP

Capacity	Internal	External
13.6GB	(31L9054)	\$145
20.0GB	(31L9056)	\$215
27.0GB	(31L9058)	\$269
34.0GB	(31L9060)	\$359

### Seagate SEAGATE

Capacity	Internal	External
8.4GB	(38641A)	\$109
20.4GB	(320430A)	\$215
28.0GB	(328040A)	\$285

### Quantum FIREBALL LCT

Capacity	Internal	External
13.0GB	(FB313000CX-A)	\$129
17.3GB	(FB317300CX-A)	\$149
20.5GB	(FB320500CX-A)	\$189
26.0GB	(FB326500CX-A)	\$269

### Quantum FIREBALL KATANA

Capacity	Internal	External
13.6GB	(FB13600K)	\$159
20.0GB	(FB20000K)	\$219
27.0GB	(FB27000K)	\$279

### Power ULTRA66

Mac IDE Accelerator

Dual Channel Internal or Tin one ext.

Ultra IDE 66 MHz

Supports 4 Drives

Great for Internal G3/4 RAID

Great for Digital Video

Transfer Rate 30Mb Read 20 Mb Write

**\$145**

## PowerStor SuperDeals

### FireSTOR™

Hot Pluggable • No SCSI ID

No Termination

~4000Mb/sec Burst Transfer Rates

Quantum FireWire 5400 rpm 512k 9.5ms Seek

Quantum Fireball \$345

IBM FireWire 5400 rpm 2048k 9.5ms Seek

IBM DeskStar \$465

IBM DeskStar \$635

FireWire 7200 rpm 2048k 8ms Seek

IBM DeskStar GXP \$395

IBM DeskStar GXP \$445

IBM DeskStar GXP \$525

IBM DeskStar GXP \$625

### PowerSTOR™

Value Hard Drives

Mac SCSI (NARROW)

Includes 50/50 DaisyChain or 25/50 Mac System Cable

Quantum 5400 rpm 512k 9.5ms Seek

Quantum Fireball \$295

5400 rpm 2048k 9.5ms Seek

IBM DeskStar \$395

IBM DeskStar \$545

7200 rpm 2048k 8ms Seek

IBM DeskStar GXP \$295

IBM DeskStar GXP \$395

IBM DeskStar GXP \$445

IBM DeskStar GXP \$545

## raid systems

[www.pdisales.com/merchant/MacRAID.html](http://www.pdisales.com/merchant/MacRAID.html)

All PowerRAIDs are Initialized, Speed Tuned, Tested and Bench Marked To Insure a True "Plug and Save" Reliability.

- Includes the Adaptec 2940U2W or Alto Ultra2 Wide Accelerator (Available with Dual Channel)
- Exclusive Raid-Tuned Hard Drives
- Raid Center Enclosures With Maximum Duty Power Supply, Teflon Shielded Cables, High Output Cooling
- Remus Raid Software
- All PowerRAID components are covered by a 5 year 48 hour replacement warranty.

### Seagate CHEETAH PowerRAIDs

Capacity	Fixed	Removable
36GB SC36	\$2395	\$2495
72GB SC72	\$3285	\$3485
108GB SC108	\$4675	\$5075
144GB SC144	\$5995	\$6495

### BARRACUDA PowerRAIDs

Capacity	Fixed	Removable
36GB SB36	\$1695	\$1895
72GB SB72	\$2695	\$2995
100GB SB100	\$2985	\$3185
150GB SB150	\$4095	\$4395

## AV TUNED Ultra2 PowerRAID

SUSTAINED TRANSFER RATES UP TO 72MB/SECOND

...SPEED TUNED!™

TRUVISION

PINNACLE

PowerRAID is on MEDIA 100's "Recommended Rides" List

All PowerRAID components are covered by our 5 Year 48 Hour Replacement Warranty.

REPLACEMENT WARRANTY

### OSA Multi Platform

Open System Architecture PowerRAIDs

Windows 95/98/NT

Apple MacOS

UNIX

- NT Servers & Clusters
- Workgroups
- Internet/Intranet Servers
- Non Linear Recording

Call or visit our website for our complete line of Open System Architecture PowerRAIDs.

## raid level 5 BARRACUDA INSIDE!

[www.pdisales.com/merchant/dv.html](http://www.pdisales.com/merchant/dv.html)

### Server RAID PowerRAID 5

Capacity	Server RAID	Price
60GB	Server RAID	\$3295
84GB	Server RAID	\$3495
100GB	Server RAID	\$3785
125GB	Server RAID	\$4475
140GB	Server RAID	\$4185
170GB	Server RAID	\$4845

### Seagate

RAID Level 0, 1, & 5

40MB/sec transfer rates

Host Independent, Mac/NT/Sun

Dual 250w redundant & load sharing hot swappable power supplies & cooling fans

Up to 128MB cache

Hot swappable drives

LCD panel for quick and easy readout of RAID status

Supports auto-rebuild

Includes Adaptec 2940UW PCI card & ext. cables Mac/PC

Great for Digital Video or Server

Service & Performance & Price & Always™

# ProDirect

10830 Nesbitt Ave. South  
Bloomington, MN 55437

Hours: Monday-Friday 9AM-7PM  
International Orders: 612-941-0012

ProDirect Fax: 612-941-1109  
Toll Free Tech Support 800-524-9952

Internet: [www.pdisales.com](http://www.pdisales.com)  
E-mail: [info@pdisales.com](mailto:info@pdisales.com)

800-524-9952

ALL PRICES ARE SUBJECT TO CHANGE WITHOUT NOTICE. RETURNED ORDERS ARE SUBJECT TO A RESTOCKING FEE. INTERNATIONAL CUSTOMERS PAY ALL SHIPPING CHARGES. ALL SHIPPING CHARGES ARE NON-REFUNDABLE. TO RETURN TO SUBJECT RETURNED CALL FOR AN RMA NUMBER. ALL RMAs MUST BE RETURNED WITHIN 10 BUSINESS DAYS OF ISSUANCE. CUSTOMERS ARE RESPONSIBLE FOR SHIPPING CHARGES TO RETURN PRODUCT.





Here's this month's hot features. Check out more at [www.megahaus.com/mac](http://www.megahaus.com/mac)

### USB Hard Drive

## USB

**17.2GB**  
Also avail in 6,8 & 13 GB  
For PC or Mac!



**\$209**  
(USB17GB)

### USB CDRW Drive

## USB

CD Rewritable  
**8x4x24 USB**  
For Mac or PC!



Ext. **\$289**  
(USB8X424)

### Hard Drive

## Quantum

**18.2 GB \$399**  
**SCSI Ultra 160/m**  
Int. (KN318200LW) Ext. **\$529**  
(KN318200LWX)



### Hard Drive

## Seagate

**9. GB \$270**  
**Ultra-2 SCSI**  
Int. (ST39175LW) Ext. **\$399**  
(ST39175LWX)



### CDRW Drive Kit

## YAMAHA

**8x4x24 \$255**  
**SCSI-2 Kit**  
W/mastering soft. & 1 disk.  
Int. (YCRW8424WOW) Ext. **\$289**  
(YCRW8424MX)



### DVD Ram Drive

## Panasonic

**1x20x2 \$459**  
Complete **SCSI-2** Kit  
Reads DVD-ROM, DVD-R, CD-R & CD-RW disks.  
2MB buffer. W/soft. & 2.6GB DVD disk. (LFD103U)



### Tape Drive

## SONY

**20-40GB \$949**  
**Ultra Wide SCSI** DDS-4  
Int. (SDT11000AI) Ext. **\$999**  
(SDT11000XM)



### 2 Gig Jaz Drive

## iomega

**2GB Jaz Drive \$315**  
**Ultra-2 SCSI**  
Ext. (JAZ2X) Ext. **\$85**  
(JAZ2GIGPC)



### HARD DRIVES

#### Quantum

**ULTRA 160m SCSI** W/ work on older SCSI Ultra Wide Ultra-1 controllers

9.1GB	7200	2MB	KN309100LW	\$255
9.1GB	7200	4MB	XC309100LW	\$270
9.1GB	10,000	2MB	TN309100LW	\$365
18.2GB	7200	2MB	KN318200LW	\$399
18.4GB	7200	4MB	XC318400LW	\$419
18.2GB	10,000	2MB	TN318200LW	\$589
36.4GB	7200	2MB	KN336400LW	<del>\$789</del>
36.7GB	7200	4MB	XC336700LW	\$809
36.4GB	10,000	2MB	TN336400LW	<del>\$999</del>

**IDE ULTRA ATA/66**

4.3GB	512K	5400	QML04300LA	\$95
5.1GB	512K	5400	QML05100LA	\$108
8.4GB	512K	5400	QML08400LA	\$115
10.2GB	512K	5400	QML10200LA	\$129
13.0GB	512K	5400	QML13000LA	\$129
13.6GB	512K	7200	KX313600A	\$163
15.0GB	512K	5400	QML15000LA	\$136
17.3GB	512K	5400	QML17300LA	\$145
20.4GB	512K	5400	QML20400LA	\$169
20.5GB	512K	7200	KX320500A	\$209
26.0GB	512K	5400	QML26000LA	\$234
27.3GB	512K	7200	KX327300A	\$269
30.0GB	512K	5400	QML30000LA	\$257

### HARD DRIVES

#### Seagate

**ULTRA SCSI**

9.2GB	7200	512K	ST39216N	\$295
18.4GB	7200	512K	ST318416N	\$399

**ULTRA-2 SCSI**

9.1GB	7200	1MB	ST39175LW	\$270
9.1GB	10,000	1MB	ST39103LW	\$369
9.1GB	10,000	4MB	ST39103LW4	\$375
18.2GB	7200	1MB	ST318203LW	\$399
18.2GB	10,000	1MB	ST318203LW4	\$579
18.2GB	10,000	4MB	ST318203LW4	<del>\$595</del>
36.4GB	7200	1MB	ST336475LW	\$839
36.4GB	10,000	1MB	ST336403LW	<del>\$899</del>
50.1GB	7200	1MB	ST150176LW	\$889

**IDE Ultra ATA/66**

4.3GB	5400	256K	ST34314A	\$96
8.4GB	5400	512K	ST38410A	\$114
13.0GB	5400	512K	ST313021A	\$133
17.2GB	5400	512K	ST317221A	\$145
20.4GB	7200	512K	ST32040A	\$179
28.0GB	7200	512K	ST32804A	\$225

### RAID

Enclosure holds 3 Hot Swappable SCA drives  
Int. (SCA3DR-LVD)\$259 Ext. (SCA3CE-LVD)\$329  
We can custom configure a RAID system to your exact needs. Call one of our RAID experts at 800-786-5653.

### G3 UPGRADES

Upgrades for G3 Mini Tower Macintosh computers  
Adaptec PCI SCSI card kit (A2906E) \$55  
20GB Hard Drive (M93652U8) \$290

### HARD DRIVES

#### IBM

**ULTRA SCSI**

9.1GB	7200	2MB	IBM309170N	\$245
18.2GB	7200	2MB	IBM318350N	\$390

**ULTRA WIDE SCSI**

9.1GB	7200	2MB	IBM309170W	\$245
18.2GB	7200	2MB	IBM318350W	\$390

**ULTRA-2 SCSI**

9.1GB	7200	2MB	IBM309170U2	\$245
9.1GB	10,000	2MB	IBM309170U2	\$360
18.2GB	7200	2MB	IBM318350U2	\$390
18.2GB	10,000	2MB	IBM318350U2	\$589
36.4GB	10,000	2MB	IBM318350U2	\$969

Call about the new 72GB drive - coming soon!

**IDE & IDE Ultra ATA/66**

13.5GB	2MB	512K	IBM13GXP	\$145
20.0GB	5400	2MB	IBM20GXP	\$195
20.3GB	5400	2MB	IBM20GXP	\$169
25.0GB	5400	2MB	IBM25GXP	\$209
27.3GB	7200	2MB	IBM27GXP	\$254
34.2GB	7200	2MB	IBM34GXP	\$340
37.5GB	5400	2MB	IBM37GXP	<del>\$335</del>

### HARD DRIVES

#### Maxtor

**IDE Ultra ATA/66**

8.7GB	7200	512K	M90871U2	\$112
13.6GB	5400	512K	M91301U3	\$129
13.6GB	5400	2MB	M91369U3	\$135
17.3GB	5400	2MB	M91737U4	\$145
17.4GB	5400	512K	M91741U4	\$140
27.3GB	5400	2MB	M92732U8	\$240
36.5GB	5400	2MB	M93652U8	\$279

**2.5" IDE LAPTOP**

4.3GB	8.45mm	Toshiba	MK4313MAT	\$159
6.0GB	9.5mm	Toshiba	MK6014MAT	\$195
12.1GB	9.5mm	Toshiba	MK1214GAP	\$309
18.1GB	12.5mm	Toshiba	MK1814GAP	\$459
6.0GB	9.5mm	IBM	DA206000	\$219
12.0GB	9.5mm	IBM	DA212000	\$349
15.0GB	12.5mm	IBM	DA215000	\$529
18.1GB	12.5mm	IBM	DA218000	\$549
25.3GB	17mm	IBM	DA225000	\$619

We carry more enclosures for drives than anybody. From single 2.5" drive cases to 20 full height RAID ready towers. We also stock a complete line of controllers for Macs. Call us with your needs.

- Diskmanager Software for larger drives on larger systems (DISKMANAGER) \$15
- PCMCIA case for 2.5" drives (PCMCIA2.5) \$129
- 2.5" drive caddies for IBM, Toshiba, NEC, Compaq & More! \$55 each

### CD ROM

• SCSI Internals • Call About Our Externals

Teac	CD532S	32X	85ms	\$82
Plextor	PX32TS (tray)	32X	85ms	\$88
Plextor	PX32CS (caddy)	32X	85ms	\$139
NEC	CDR3010	40X	85ms	\$72
Toshiba	XM6401B	40X	85ms	\$79
Plextor	PX40TS	40X	85ms	\$98
Kenwood	UCR415	52X	90ms	\$159

• WIDE SCSI •

Plextor	PX40TSUW	40X	85ms	\$99
---------	----------	-----	------	------

• IDE •

Teac	CD540E	40X	85ms	\$46
NEC	CDR3000	40X	75ms	\$48
Mitsumi	CRMCFX48X	48X	65ms	\$46
Creative	SBCD52	52X	100ms	\$45
Kenwood	UCR412	52X	90ms	\$86
Kenwood	UCR421	72X	90ms	\$124

• CD CHANGER •

Pioneer 24 X6 Disc Ext. SCSI (DRM6324X) \$395

### MEDIA

Nobody Beats MegaHaus for CD media. Larger quantities available.

• CD RECORDABLE MEDIA • Max Speed

5 Pack [CDR74B-5]	8x	\$6
20 Pack [CDR74B-20]	8x	\$23
50 Pack [CDR74B-50]	8x	\$55
100 Pack [CDR74B-100]	8x	\$99

• New 80 MINUTE MEDIA •

5 Pack [CDR80-5]	8x	\$9
20 Pack [CDR80-20]	8x	\$25
50 Pack [CDR80-50]	8x	\$59
100 Pack [CDR80-100]	8x	\$109

• CD REWRITABLE MEDIA •

Budget 5 Pack [CDR74WB-5]	4x	\$9
Budget 20 Pack [CDR74WB-20]	4x	\$25
Budget 50 Pack [CDR74WB-50]	4x	\$59
Budget 100 Pack [CDR74WB-100]	4x	\$109
5 Pack [CDR74W-5]	4x	\$25
20 Pack [CDR74W-20]	4x	\$79
50 Pack [CDR74W-50]	4x	\$195
100 Pack [CDR74W-100]	4x	\$395

• CD-R PRINTABLE SURFACE •

Budget 5 Pack [CDR74PB-5]	4x	\$9
Budget 20 Pack [CDR74PB-20]	4x	\$25
Budget 50 Pack [CDR74PB-50]	4x	\$59
Budget 100 Pack [CDR74PB-100]	4x	\$109
5 Pack [CDR74P-5]	8x	\$12
20 Pack [CDR74P-20]	8x	\$49
50 Pack [CDR74P-50]	8x	\$89
100 Pack [CDR74P-100]	8x	\$175

• CD RECORDABLE PLATINUM MEDIA •

5 Pack [CDR74PA-5]	8x	\$11
20 Pack [CDR74PA-20]	8x	\$33
50 Pack [CDR74PA-50]	8x	\$75
100 Pack [CDR74PA-100]	8x	\$139

**OPTICAL MEDIA**

Size & Description	1-4	5-9	10+
128MB, 3.5", 512K	\$13	\$9	\$7
230MB, 3.5", 512K	\$14	\$10	\$8
640MB, 3.5", 2048K	\$21	\$17	\$15
650MB, 5.25", 1024K	\$25	\$23	\$21
1.2GiB, 5.25", 512K	\$25	\$23	\$21
1.3GiB, 5.25", 1024K	\$26	\$24	\$22
2.6GiB, 5.25", 1024K	\$33	\$29	\$27
5.2GiB, 5.25", 2048K	\$70	\$68	\$64

• BACKUP TAPES •

4mm DAT 120M	2-4	5-9	10+
4mm DAT 125M	\$16	\$13	\$11
8mm DAT 150M	\$31	\$28	\$26
TR4	\$59	\$57	\$55
TR5	\$29	\$27	\$25
	\$47	\$45	\$43

### WESTERN DIGITAL

**IDE Ultra ATA/66**

4.3GB	5400	512K	WDAC43AA	\$99
6.4GB	5400	512K	WDAC64AA	\$109
8.4GB	5400	512K	WDAC84AA	\$115
10.2GB	5400	512K	WDAC102AA	\$119
13.0GB	5400	512K	WDAC136AA	\$133
15.3GB	7200	2MB	WDAC153BA	\$150
18.0GB	5400	2MB	WDAC180AA	\$159
20.5GB	5400	2MB	WDAC205AA	\$185
20.5GB	7200	2MB	WDAC205BA	\$220
27.3GB	7200	2MB	WDAC273BA	\$275
30.0GB	5400	2MB	WDAC307AA	\$230

We are committed to being the #1 Source for hard drives for Macintosh. If you need a drive or drive accessory not listed here, we probably have it. Call for pricing and availability.

## Nobody beats our deals.

## Nobody has more drives.

### REMOVABLE MEDIA

**Iomega**

100MB Zip Ext SCSI/AUSB	\$109/\$119
250MB Zip Ext SCSI/AUSB	\$145/\$165
2GB Jaz Internal SCSI	\$309
2GB Jaz External SCSI	\$315
1GB Jaz disk 2-4/5-9/10+	\$80/77/75
2GB Jaz disk 2-4/5-9/10+	\$85/80/77

**Sony Magneto Optical**

5.2GB SCSI-2 Int. 4MB buffer (SMOPFS1)	\$1399
5.2GB SCSI-2 Ext. 4MB buffer (SMOPFS1X)	\$1539
5.2GB optical media (SMAXS2) 1-4/5-9/10+	\$83/80/77

DLT II

DLTIII 10-20GB	\$36	\$34	\$32
DLTIIIHX 15-30GB	\$39	\$36	\$34
DLT IV 20-40GB	\$69	\$67	\$65
DLT Cleaning Tape	\$40	\$39	\$36





"Macworld Lab has proven to be one of the most pristine and controlled lab environments to which we've provided our scanners and software for testing."

Jon Guerringue, Marketing Manager  
Heidelberg Color Publishing Solutions

the most rigorous



in the

industry

#1. Planning. Researching. Testing. Analyzing.  
Re-testing. Double-checking. Nobody adheres to stricter, more

rigorous guidelines than the lab specialists whose work is dedicated to Mac product testing at Macworld Lab.

Macworld Lab is the largest independent testing facility for Mac OS products and systems. Our lab specialists apply more than 30 years' combined experience to ensure that testing methodologies represent a product's real-world use.

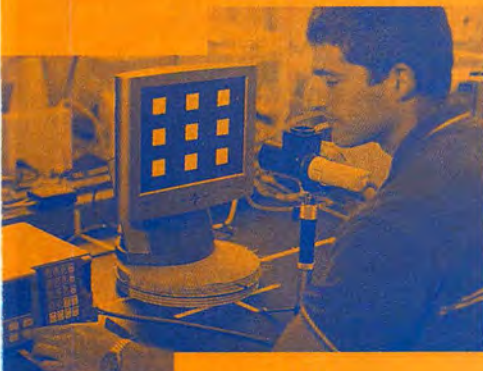

Macworld

Macworld  
LAB TEST

Macworld  
TESTING



# Developer Showcase

## Welcome to the Developer Showcase



**Macworld** magazine, in conjunction with the *Apple Developer*

*Connection*, built this **NEW** specialized advertising section to keep you, our

valued reader, apprised of some of the **hottest** products available for your Mac. Due to the unparalleled

popularity of *Apple* computer systems like the *iMac*, *PowerBook G3* and

*PowerMac G4*, more than ever before developers are releasing new Mac-compatible

**software** and **hardware** products. **Be sure to check this section each**

**month** where you'll find a wide variety of innovative solutions that will make your **Macintosh**

experience even more pleasurable! **Contact Niki Stranz or Carol Johnstone at: (800) 597-1594**

**Macworld**  
AppleDeveloper

## ORGANIZE IN STYLE

New! **Consultant 3.0**



Consultant is the Swiss Army knife of productivity software. It's a calendar, address book, word processor, project manager, memo taker, phone dialer and alarm clock all rolled into one.



The new Office Consultant™ brings client/server power to your office network

Sync with any PalmPilot™ or Visor™ handheld organizer

THE SUIT, ITALIAN

THE TIE, SILK

THE WATCH, SWISS

THE ORGANIZER, CONSULTANT

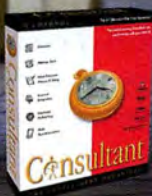

Order Consultant today!  
Call (801) 957-1774  
or download a copy at:  
[www.chronosnet.com](http://www.chronosnet.com)

Now Up-to-Date™ Users, get your professional upgrade for \$29 (for a limited time)

 **CHRONOS**

All trademarks are the property of their respective owners



MacAddict '98



ZDNet '98



1999 Eddy Award Winner  
Macworld '99



**Simple** to use...  
and extremely **Powerful**...

## Aatrix® Accounting

ACCOUNTING SOFTWARE



Comprehensive, Payroll

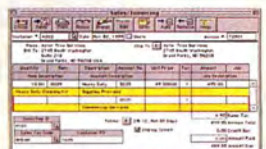

Easy Bill Paying, Accounts Payable

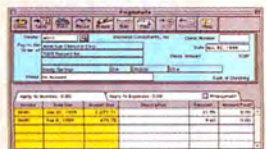

Custom Invoices, Accounts Receivable



- General Ledger
- Accounts Receivable
- Accounts Payable
- Payroll Inventory
- Job Tracking
- Budgeting
- Custom Invoices
- Custom Checks
- Year End Procedures
- Invoice Customers
- Report Writer
- Mac OS 9 Compatible
- \*Meets Aatrix's Year 2000 Compliant Standards

**\$129.99**  
Special Price

For more information call us at: **1.800.426.0854**  
or visit our web site at [www.aatrix.com](http://www.aatrix.com)



©1999 Aatrix Software, Inc. Aatrix is a trademark of Aatrix Software, Inc. All other trademarks are property of their respective holders. \*Aatrix's Year 2000 Standards can be found at: <http://www.aatrix.com/1.800.426.0854/y2k/index.html>

Point-of-Sale

Inventory Management



Nationally, more than 3,500 Retailers partner with POS•IM software systems for increased profits!

## Retailers' Power Partner...

### More Profits

Increased profits come to Retailers who apply the powerful features of POS•IM, the proven POS software system for Point-of-Sale, and Inventory Management. See why

retailers choose POS•IM, including Apples' own company store. FREE introductory CD, call (800) 409-7678



## Finally, A Table for Your iMac That Combines Function, Quality and Design

Recessed Monitor Tray

Recessed Storage for CD's, Floppy Disc, and Folders

Drink Holder



Slide-Out Keyboard Tray

Heavy Duty Steel Leg with Levelors

Leg Color to Compliment Your iMac

Table.....\$369  
Keyboard.....\$49  
Recessed Monitor Tray.....\$39

Shipping in US except Hawaii and Alaska \$48.00  
iMac is a registered trademark of Apple Computer, Inc.

**environment ltd.**  
Custom Furniture Manufacturer  
since 1971  
For sales and information  
**281.983.0100**

[www.environmentlimited.com](http://www.environmentlimited.com)



# Developer Showcase

Whether you're an old hand, or just a pup, Yellow Dog Linux **Gone Home™** offers a wonderful combination of speed, stability, and the very playful best of Linux for your Power Macintosh.

An operating system for you, your neighbor ... and your dog, by Terra Soft Solutions, Inc.

[www.yellowdoglinux.com](http://www.yellowdoglinux.com)

© 2000 Terra Soft Solutions, Inc. All rights reserved.

# TypeStyler™ 3

The ultimate styling tool for Internet, Print and Video.

You just won't believe your eyes! The new TypeStyler is a powerhouse of spectacular special effects, yet retains the friendly ease of use that made the original TypeStyler so popular.

TypeStyler is the graphic designer's backroom secret weapon. Create dazzling web graphics, headlines, ads, signs, posters, videos titles and more in minutes, instead of hours!

TypeStyler is a complete stand-alone design, layout, and effects program yet also works seamlessly with Photoshop, Illustrator, GoLive, XPress, PageMaker, InDesign, FreeHand, FireWorks, and more.



- Includes style and shape libraries, design templates & 110 of the world's coolest fonts.
- Always editable -- text, shape & style -- makes changes & design reuse a snap.
- Unlimited text shaping -- circles, arcs, distortions -- any shape you can imagine.
- Integrated path editing tools to create virtually any logo or custom design.
- Create buttons, banners, image maps and JavaScript rollovers for the Web.
- Export as Photoshop layers, Illustrator, GIF, PICT with alpha, EPS, & more.

To order, call 906-863-7798 or visit us at: [www.typestyler.com](http://www.typestyler.com)

©1999 Strider Software, Inc. Brand and product names are trademarks or registered trademarks of their respective holders.

## LIND

Automobile / Airline Power Adapters for iBook and PowerBook

- Engineered to the highest standards of quality, safety & reliability!
- Scaled for protection against moisture & high humidity!
- Filters the input line voltage against spikes or surges!
- Emulates the output of your AC power supply!
- Input Low Voltage Shutdown Protection!
- Output "Short Circuit" Shutdown!
- Automatic Adapter Reset!
- Rugged Housing for Durability!
- 3 year warranty!

Simply the Right Choice!

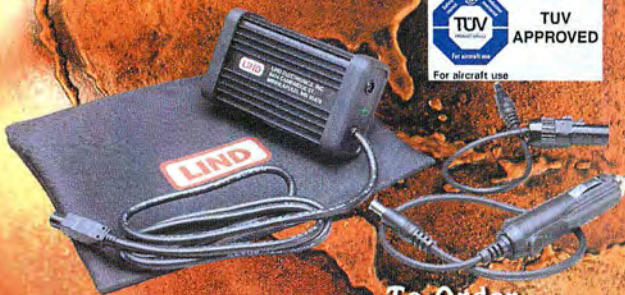

To Order  
Call 800-897-8994  
or go to:  
[www.lindelectronics.com](http://www.lindelectronics.com)



Lind Electronics, Inc.  
6814 Cambridge Street  
Minneapolis, MN 55426  
713-897-8994  
FAX 612-927-7248

## BookEndz® Docking Station For the 1999 PowerBook® G3 Series

Converts your PowerBook to a desktop system (or back) in seconds!

- No assembly required
- Supports all rear ports
- Eliminates cable confusion
- Dock or undock in 2 seconds
- Lighted power/docked indicator
- No more file synchronization problems
- Includes a security slot to prevent theft
- Attach your peripherals to the dock once
- Insert or remove PC cards while docked
- Adds only 3" to rear of PB when docked
- Color and style matched to your PowerBook
- Eliminates the need for a separate desktop computer
- Will not interfere w/ IR port, security slot, or media bays

**\$229.95** esp

[www.pilot-tech.com](http://www.pilot-tech.com)

Pilot Technologies, Inc., Minneapolis MN  
Tel: (612) 828-6002 Fax: (612) 828-6806  
Email: [info@pilot-tech.com](mailto:info@pilot-tech.com)



# Quickly Build and Deploy Powerful Data-Driven Web Applications



New  
Product



New 3.6  
Version

## Lasso Products Lead The Way.

Building custom database-driven Web sites requires a whole new way of doing things. Blue World and the Lasso Web Data Engine™ consistently lead the way providing a feature set Web developers describe as "incredible." Build online stores, discussion forums, resource management systems and other demanding database-driven Web applications with unrivaled performance, ease, security, extensibility, control and flexibility. Develop using multiple languages—including LDML, CDML, Server-Side JavaScript, Java and XML—and deploy across multiple platforms. Your Lasso code works identically regardless to which database you're connected. Lasso solutions for FileMaker Pro databases easily scale to big iron ODBC-compliant databases like Oracle, Sybase and more with little or no change.

Find out why hundreds of thousands of websites rely on award-winning Lasso technology for their business critical Web data. Download a 30-day evaluation copy at [www.blueworld.com/download/](http://www.blueworld.com/download/) or order securely online today at the Blue World Store at [store.blueworld.com](http://store.blueworld.com).

**Lasso Product Line – The leading Web database tools for Macintosh and beyond.**

bring business to the internet.™

**blueworld**



# Developer Showcase

## Ahhh... PROfection!

G4/Final Cut Pro/Sony Bundles

148 GB of EIDE Storage Only \$2030 Stores 10.8 Hours of DV



Free Training Book and Royalty Free Music With Purchase of Final Cut Pro

### FireMAX Studio/Pro: The Perfect DV Editing Solution

**FireMAX Studio/Pro** is a professional video editing system that delivers perfect digital video from start to finish via FireWire/1394 and includes Apple's Final Cut Pro v1.2.1 software and Sony peripherals. The system is greatly expandable with dozens of audio and video effects plug-ins. **FireMAX Studio/Pro** is capable of long form video editing and features time saving batch capture with time code, perfect audio sync, three point editing and more.

#### FireMAX Studio/Pro Bundles:

FireMAX-C Card plus Final Cut Pro v1.2.1

Options:

Media Cleaner Pro v4.0 with any FireMax/Pro bundle 399  
Boris FX v3.01 with any FireMAX/Pro bundle 399  
Programmable 20 button, USB, jog/shuttle control station 429

**\$1199**

#### FireMAX Studio/Pro Core System Plus a Sony DCR-TRV8 DV Camcorder:

Includes **FireMAX Studio/Pro Core System** plus an easy to carry Sony DCR-TRV8, single CCD, camcorder with FireWire in/out, analog in/out (converts analog to DV), and a 3.5" LCD monitor. If DCR-TRV900 - 3 CCD Camcorder - instead of TRV8 8245

**\$7345**

#### FireMAX Studio/Pro Core System:

Power Macintosh - Graphite - G4/400 MT, 256 MB of RAM, ZIP, 19" RGB monitor, 37 GB EIDE drive with a TurboMAX PCI EIDE host adapter (163 minutes of video), Final Cut Pro, a four meter FireWire cable, powered speakers, 14" Sony studio monitor. System configured and tested. One year toll free system support.

Add an additional 163 minute 37.0 GB TurboMAX drive 475

**\$5945**

#### FireMAX Studio/Pro Complete as Pictured Above With Sony DSR-PD100a:

Includes **FireMAX Studio/Pro Core System** plus a DSR-PD100a three CCD Sony DVCAM camcorder, Sony DSR-20 DVCAM deck, Smart Sound Pro, and Media Cleaner Pro software for creating files capable of streaming on the web or CD-ROM. Our **FireMAX Studio/Pro Complete** is ready to use digital video editing solution. If Canon XL1 - 3 CCD Camcorder - instead of a PD100a 13540

**\$12039**

#### G3/400 PowerBook Portable Editing System



#### FireMAX Portable Studio/Pro

##### FireMAX Portable Studio/Pro Core System:

G3/400 PowerBook, 192 MB of RAM, 6 GB EIDE boot drive plus a 37 GB external FireWire drive, Final Cut Pro, ProMax DV-Toolkit plug-in, FireWire cables, and a MacAlly USB mouse. Includes a padded carrying bag. System fully configured and tested. One year of toll free system support.

Core System Plus a GV-D900 Walkman With 8 Hour Battery 8175  
Additional 95 Minute 37 GB FireWire External Drive 645

**\$6495**

#### iMacDV-SE G3/400



#### DV Editing System

#### FireMAX Studio/iMacDV-SE

##### FireMAX Studio/iMacDV-SE Core System:

G3/400 iMacDV-SE, 192 MB of RAM, 37 GB EIDE IBM disk drive, Adobe Premiere 5.1c, BorisFX, Sony 14" studio monitor, ProMax DV-Toolkit with low-res capture and FireSNAP, a FireWire cable, a pair of Altec-Lansing speakers, Smart Sound Pro, and Media Cleaner Pro for creating video for streaming on the web or CD-ROM. System is fully tested. One year toll free system support is included.

FireMAX Studio/iMacDV-SE With Sony DCR-TRV8 Camcorder 5770

**\$4375**

### SONY

#### Camcorders

DCR-TRV8 1 CCD DV Camcorder  
DCR-TRV900 3 CCD DV Camcorder  
DSR-PD100a 3 CCD DVCAM Camcorder



#### DV Walkmans

GV-D900 Portable DV Deck. Includes 5.5 inch LCD Display and Speaker. Offers FireWire, S-Video, Composite, and RCA Audio Input/Output. Includes A/C Battery Charger. Uses 60 Minute DV Cassettes. GV-D300 Same But With No Monitor or Speaker.

Ask About New JVC GY-DV500U Camcorder

### Canon

GL1 - 3 CCD DV Camcorder With Display, Fluorite Crystal Lens, Digital Zoom to 100x.

XL1 - 3 CCD DV Camcorder With Removable Lens.



The Above Systems Can be Configured to Meet Your Exact Needs - Call For Quote and Find Out Why FireMAX Studio is a Perfect Solution - Visit [www.promax.com](http://www.promax.com) Ask About Our New Video Boot Camp Training Classes For Digital Video Production

1-800-977-6629

Apple Specialist

# proMAX

## ProMax Systems, Inc.

16 Technology Drive - #102 to #106 • Irvine, CA 92618  
SALES: 1-800-977-6629 • TEL: 949-727-3977 • FAX: 949-727-3546

Prices subject to change without notice - usually lower. Prices based on our 1.5.00 price list. Delivery subject to availability. Returns are subject to 25% restock fee.

## We Custom Configure Macintosh Computers

Apple Specialist

Purchase of Apple Products Must be Made Through a Direct VAR Location

#### Video Editing Hardware/Software:

Apple G3/400, G4/350, G4/400, G4/450, and RGB Monitors  
Apple Final Cut Pro - Editing Software With Free Book or Training CD  
Adaptec AHA-2940UW, 3940UW, 2930 SCSI Cards  
Adobe After Effects, Photoshop, Illustrator, and PageMaker  
Beachtek Dual XLR Microphone Adapters  
Bogen Tripods and Heads  
DVD Creation: DVD Pioneer DVD-R Drive and Astarte DVDirector  
JVC Professional DV Camcorders  
Mackie Audio Mixers and Powered Speakers  
Media 100 OX, OXC, LE, and LX  
Microphones and Lighting Kits - Call For Details  
Monitors: Sony NTSC - Radius and ViewSonic RGB  
Sony AIT Tape Backup Systems With Retrospect  
Terran Interactive Media Cleaner Pro  
Yamaha CDR Writers With Toast Software



ASTARTE

JVC PROFESSIONAL



#### SteadyTracker Stabilizers • CobraCranes

SteadyTracker UltraLite For Small Camcorders \$399  
SteadyTracker EX Xtreme For Small Camcorders 599  
CobraCrane 1 Requires a Tripod - Bogen 3140 399  
See Our Web Page For Additional Information

#### Ask About Pioneer DVD-R and Panasonic DVD-RAM Drives

**NEW FireWire Disk Drives**

37 GB ProMax External Drive With Power Supply and FireWire Cable \$645  
FireNET FireWire Network Multiple G3 BW, G4, and iMacDV's Per Seat 99

#### Macintosh SCSI Disk Arrays High Performance LVD SCSI RAID Systems

LVD Ultra2 Wide SCSI Disk Arrays to 80 MB/sec - 300 KB PF Hot Swappable Canners With Security Lock and Resettable Audible Alarm

36 GB Ultra2-SCSI 2 Drive Array - LVD 18 GB Barracuda Drives - ST-318275LC \$1545  
100 GB Ultra2-SCSI 2 Drive Array - LVD 50 GB Barracuda Drives - ST-150176LC 2495  
200 GB Ultra2-SCSI 4 Drive Array - LVD 50 GB Barracuda Drives - ST-150176LC 4795

Arrays Ship With Power Card, Disk Drives, a Cabinet With Removable Fan, and Heavy Duty Power Supply

#### Add For SCSI Kit - Card, Cable, and Terminator

Ultra2 SCSI Kit AHA-2940UW, 5' Cable, LVD Terminator, Remus \$589  
Ultra SCSI Kit AHA-2940UW, 3' Cable, Active Terminator, Remus 425  
SCSI Adapter AHA-2940W Adaptec UltraWide SCSI Host Adapter 229  
SCSI Adapter AHA-2930 - For Blue G3 and G4's to Run Legacy SCSI Devices 89

#### TurboMAX Storage Macintosh Ultra DMA ATA Disk Drives

TurboMAX PCI Host Adapter and 11 inch Data Cable \$199  
25 GB Internal Drive and 11 inch Data Cable 325  
37 GB Internal Drive and 11 inch Data Cable 475  
74 GB Internal 2 Drive System - Card and Cables 1080  
148 GB Internal 4 Drive System - Card and Cables 2030

## VIDEO BOOT CAMP!

Three 2 Day Classes Held in Our Irvine Training Center:  
#1 - "The Secrets of Final Cut Pro" • Hands-on Software Training  
#2 - "DV Cinematography" • How to Shoot DV For Film Look  
#3 - "DVD Creation" • Authoring & Mastering DVD-Video Disks  
For Information or To Register: See Our Web Page / Calendar of Events

#### ProMAX Offers Lease Programs With Purchase Options

Call 1-800-977-6629 • 7 am to 6 pm M-F Pacific Time  
8 am to 4 pm on Saturday • Most Credit Cards Accepted  
We Ship by Federal Express and Offer Expert Technical Support

Trade names are the property of their respective owners.



## Think smaller...

### MiniCDRW XS4424

XS4424 = 4X Write  
4X Re-Write  
up to 24X Read

Archos announced their commitment to Thinking smaller with the introduction of the MiniCDRW to their line of portable peripherals. Delivering a mobile storage solution for both PC and Mac notebook and desktop users, the MiniCDRW provides unprecedented CD-R/CD-RW technology for reading, copying and compiling CDs wherever you may be.

- Read at up to 24X, Write and Re-Write at up to 4X
- CD Mastering Software Included
- On The Fly Recording Of MP3 Files Into Audio CD
- Choose Among USB, PC Card, CardBus, or FireWire Interfaces

1-800-559-3605



PC Card/CardBus



Archos Technology  
15375 Barranca Pkwy, Suite J101  
Irvine, CA 92618  
Tel: (949) 453-1121  
Fax: (949) 453-1139  
E-mail: us-info@archos.com

Archos SA  
ZI - 12, rue Ampere  
91430 Igny - France  
Tel: 011 33 1 69 33 1690  
Fax: 011 33 1 69 33 1699  
E-mail: euro-info@archos.com



www.archos.com

## IS THERE AN ECLIPSE IN YOUR FUTURE?

INTRODUCING ECLIPSE FROM BELLSTOR,  
the first simple high-performance storage  
solution. Featuring the high-speed FireWire  
interface, the BellStor Eclipse is available in  
Hard Disk, Tape and CD-RW models.

- Data transfer rates up to 400 Mbps
- Simple Plug & Play installation
- Hot-Pluggable
- Auto-configuring
- No device ID's or termination

BELLSTOR  
SIMPLIFYING STORAGE SOLUTIONS



www.bellstor.com • (800) 800-1513



# Developer Showcase

## PowerRIP 2000

For Epson ink jet printers

**Advanced Color Management saves time and money on color proofing.**

**Industry standard ICCs and color rendering dictionaries for accurate color reproduction.**

**DCS 1.0 and DCS 2.0 support enables color separations and spot colors to be turned into a composite color proof allowing you to see color traps.**

- ▶ Network ready, Server/Client & cross-platform configurable
- ▶ Supports all Epson Stylus printers/Mac USB on most
- ▶ ICC output profiles for Epson's inks and papers as well as iProof's PressProof stock, at all available resolutions
- ▶ Accepts user defined ICC target profiles
- ▶ SWOP, FOGRA/Eurostandard, Toyo, and DIC color simulation
- ▶ Convert spot colors to Pantone matched user defined colors



GET ALL THE DETAILS ONLINE  
[www.iproofsystems.com](http://www.iproofsystems.com)  
 321-254-4401 • Fax 321-254-6899

## The Perfect VIDEO Solutions for iMac and iBook



I can mirror from iMac & iBook to TV & Projectors!

**USB Presenter™-SI**



I am able to do that too!  
 Also, playback Motion Video.

**USB Presenter™-MV**



I can do all that!!! PLUS, I capture & allow Video Editing from Camcorders or VCRs to iMac & iBook. Then, create Video Clips for video emailing or web authoring.

**iMaxEdit™-USB**

**AverMedia**  
 MicroSystems

\* Also compatible with G3 & G4

1-800-863-2332 ext.1606 [www.avermicro.com](http://www.avermicro.com) [usbinfo@aver.com](mailto:usbinfo@aver.com)

# What every RAD tool wants to be when it grows up

Omnis Studio is the most powerful and flexible RAD tool available for the Mac.

Omnis Studio allows you to develop on your favorite platform and deploy your solution wherever your customer needs it: Mac, Win 95/98/NT or Linux. In addition, you can call your data from Oracle, DB2, Informix, Sybase or a number of other ODBC compliant databases. Omnis Studio means you can develop where you want, deploy where you want, data store where you want.

Omnis Studio is also a powerful tool for deploying data driven solutions to the web (internet or intranet) without using Java or HTML and in a fraction of the time it might otherwise take.

Continuously being updated to reflect your needs and the latest OSs available, including OSX, and costing

just \$149 for the complete product, there's never been a better time to take advantage of all the functionality that Omnis Studio has to offer. Make the mature choice: call us today on 1-800 34 OMNIS or check it out on [www.omnis.net](http://www.omnis.net).



**OMNIS**

[www.omnis.net](http://www.omnis.net)



# GBSTAT<sup>TM</sup> 6.5

**Statistics Made Simple.<sup>SM</sup>**

Order Today and Save \$150!

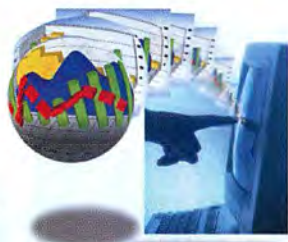

*Continuously developed for Macintosh since 1987.*

- ◆ Intuitive and easy-to-use
- ◆ Over 300 statistical tests
- ◆ Modify GB STAT graphs in MS PowerPoint<sup>TM</sup>, MS Word<sup>TM</sup> & others
- ◆ Free demo available

*"GB STAT is very easy to use. I am able to find the procedures I want without difficulty."*

William H. Neches, MD  
Prof. of Pediatrics, Children's Hospital, Pittsburgh, PA

Order your copy before June 30, 2000 for only \$549 (reg. \$699) when you mention code COV04.

www.scolari.com • 805.499.1325 • gbstat@scolari.com

Can uConnect<sup>TM</sup>

to your iMac?

uConnect

UNIVERSAL Mac & PC connectors

uConnect Extreme

ALL IN ONE  
3 uConnects + extra usb port

(877) 381-1400  
www.momentumus.com

# PrintChef<sup>®</sup> 3

Add PrintChef to your print dialog today...

...and get all these great printing possibilities!

- booklets
- watermarks
- toner/ink control
- create bar codes
- design new paper sizes
- miniature pages & labels
- collect files into one print
- create letterheads
- front-back printing

...for International callers  
Worldwide: (931) 937-6800  
Fax Orders: (931) 937-6801

PrintChef boosts the printing power of any application printing with any printer!

Call (800) 648-6840... or experience PrintChef Lite (shareware), and get other information at our web site. [www.mindgate.com](http://www.mindgate.com)



MindGate<sup>®</sup> Technologies, Inc.  
164 Oliver Smith Road  
Fintville, TN 37335-5335

MindGate, PrintChef, and their logos are registered trademarks and "print different" is a trademark of MindGate Technologies, Inc.

PrintChef is a printing extension that sits between ANY application & ANY printer driver... It uses Printing Styles that we design or that you design to control the printing process...

Compatible with Mac OS 7.8, 9; Win 95/98 and NT 4/5; FREE upgrade to the Mac OS X and Win 2000 when available. Works with 680x0, PowerMac, G4, and Intel-based machines.

futurebasic

Meet the future of programming

- Open source runtime
- Full access to the Mac toolbox
- PPC/68K compiles
- Access to shared libraries

[www.stazsoftware.com](http://www.stazsoftware.com) • 800.348.2623



# Developer Showcase

## MONKEYBYTE.com

PLAY BEFORE YOU PAY!

# MONKEY BYTE

Games for the Family.

Get connected with CH Products, [www.chproducts.com](http://www.chproducts.com)

- Flight Sim Yoke USB
- F-16 Fighterstick USB
- F-16 Combatstick USB
- Gamestick 3D USB
- Pro Throttle USB
- Pro Pedals USB
- Gamepad USB
- Gamecard GC3

CH Products  
760.598.2518  
[www.chproducts.com](http://www.chproducts.com)

WWW.FREEVERSE.COM

# Deathground™

1999 MACWORLD GAME HALL OF FAME

MacHome ZDNet

THE BEST MAC CARD GAMES NOW HAVE INTERNET PLAY

ON THE

# HMS FREEVERSE

FREE 30-DAY TRIAL

CLASSIC CRABBLE

SPADES DELUXE

AND OTHERS...

WWW.FREEVERSE.COM



## Your Music CD's just learned how to paint.

Download the Free Onadime Player and Music-Visuals collection!

Experience the next level of Digital Art: Real-Time Imaging



[www.onadime.com](http://www.onadime.com)

100's of Artworks with real-time dynamics available online.

Order your 'See the Music' cd-rom online or call 877.662.9037.

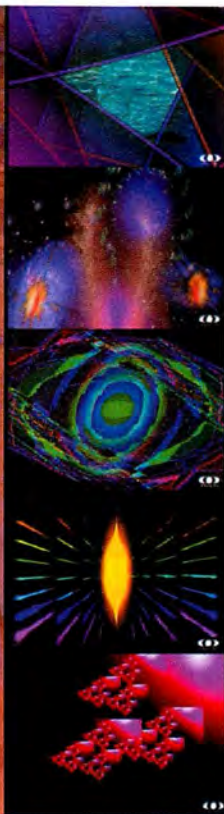

## ADESSO KEYBOARDS

Input Specialists

----- and a whole lot more!!

USB 



Visit us at [www.adessoinc.com](http://www.adessoinc.com)

Stop by Booth 648 at MacWorld in San Francisco

## AlphaSmart 3000 Portable Word-Processor

**Simple & Portable:** Full-Size keyboard. Weighs 2 pounds. Holds about 100 pages of text. Type in notes, minutes, memos, field data, etc. Plug into computer (or just point with infrared feature), press send, text flows into your application...that's it!

**Compatible:** Uploads to ANY application on virtually ANY computer via infrared or USB port. Prints directly to most printers.

**Reliable:** Rugged design. 3-year warranty. Unlimited toll-free support.

**Long Battery Life:** 200-500 hours on 3 AA batteries.

**Affordable: \$199.** Cables & infrared pods sold separately.

**SmartINPUT**

[www.smartinput.com](http://www.smartinput.com)

24-Hour Order Line:

**1-800-366-8323**

30-day money back guarantee

### Features:

- True plug & play
- One key send
- Spell checker
- Keyword search
- Keyboarding timer
- AutoSave & AutoPower Off
- Cut, copy & paste
- Password protection
- Two-way transfer available
- Features for special needs: sticky keys, key repeat control and four keyboard layouts

### Applets:

Add little software applications to your AlphaSmart 3000 to extend its functionality.





**PRODUCT INDEX**

Category	Page No.	Category	Page No.
<b>Business Operations</b> .....	<b>154</b>	<b>Peripheral Products</b> .....	<b>158-160</b>
Bar Code		Cables	
Inventory Management		CD Rom	
<b>Education/</b>		Digital Media	
<b>Entertainment</b> .....	<b>155</b>	Magnetic Media	
Discount Software		Printing Supplies	
<b>ISP</b> .....	<b>158-159</b>	<b>Services</b> .....	<b>170-173</b>
Web Hosting		Data Recovery	
<b>Memory &amp; Upgrades</b> ..	<b>167-169</b>	Digital Production	
<b>Systems &amp; Peripherals</b> ..	<b>160-167</b>	Printing	
<b>USB</b> .....	<b>156-158</b>	Repair	
.....		<b>Classifieds</b> .....	<b>173</b>
<b>Digital Advertising Coordinator:</b>		<b>Account Manager:</b>	
Alan Anzalone.....415.243.3511		Carol Johnstone.....415.243.3691	
production@macworld.com		carol_johnstone@macworld.com	
		<b>Account Manager:</b>	
		Niki Stranz.....415.243.3664	
		niki_stranz@macworld.com	
		<b>Assistant and Classifieds Rep:</b>	
		Alissa Mach.....415.243.3628	
		alissa_mach@macworld.com	

**Mouse Pads**



**Great Desk Advertising**  
**Custom Printed**  
**Manufacturer Direct**

**MicroStore™ Inc.**  
P.O. Box 125 • Le Sueur, MN 56058  
800-962-8885 Fax: 507-665-2604  
[www.microstore-mousepads.com](http://www.microstore-mousepads.com)

161 on card or [www.macworld.com/getinfo](http://www.macworld.com/getinfo)

**Want to Print Bar Code Labels?**

**maclabel.com**

**LABEL PRINTERS**  
USB  
Ethernet  
Appletalk  
HP PCL5, LJIII

**IntelliTech INTERNATIONAL**  
PH: 800-694-3034  
iii@intellibar.com

**BAR CODE SOLUTIONS**



**UPC/EAN/ISBN**  
**Code 39**  
**Code 128**  
**Interleaved 2 of 5**  
**POSTNET/FIM**  
**And more!**

Visit us online at:  
[www.bearrock.com](http://www.bearrock.com)

**Bear Rock Offers:**  
*Free Expert Consultation,  
Lifetime Technical Support  
and Satisfaction Guaranteed  
on ALL Bar Coding products!*



**FREE Handbook**  
"Bar Code Basics"  
A User's Guide to Bar Coding

**Call Today for a FREE Consultation!**  
**800 232-7625**  
Intl: (530) 672-0244 Fax: (530) 672-1103

160 on card or [www.macworld.com/getinfo](http://www.macworld.com/getinfo)

**Call Us Toll Free 800-345-4220**

**Broadest Selection of Bar Code Products in the Industry**

- Technically superior products direct from the manufacturer
- Toll free technical and pre-sale support
- 24-hour turnaround on repairs
- Free UPS Blue shipping in U.S.
- 30-day money back guarantee

- Portable & non-portable Batch Readers
- Cordless interactive R/F Terminals
- Wand, Laser, CCD, Magstripe or Slot Badge
- PostScript bar code fonts

or visit our website at  
**www.BarCodeHQ.com**  
for a complete catalog and bar code primer

**WORTH data**

Worthington Data Solutions is now...  
Phone: 831-458-9938 • Fax: 831-458-9964

**POINT OF SALE • INVENTORY CONTROL**

**Software & Hardware for:**

- Retail/Wholesale
- Mail Order
- Internet Commerce
- Rentals
- Service/Repair
- Manufacturing
- FileMaker Tools

Fully Integrated Accounting  
Multi-Site Polling • Cross Platform  
Barcode Readers • Receipt Printers  
Cash Drawers • Mag Stripe  
Ribbons/Paper/Labels  
Credit Card Authorization  
& Deposit Software

**Now iMac compatible**

**www.posdirect.com**  
(800) 622-7670 • sales@posdirect.com  
(618) 985-8237 vox • (618) 985-3014 fax

**P.O.S. DIRECT**

Order Free CD Rom on Web Site

165 on card or [www.macworld.com/getinfo](http://www.macworld.com/getinfo)

**"MACWORLD CONSISTENTLY PRODUCES INQUIRIES AND RESULTS! NEW & REPEAT CUSTOMERS ALL SAY: 'I SAW YOUR AD IN THE MACWORLD SHOPPER.' KEEP UP THE GOOD WORK!"**

**DAVID ASH**  
OWNER  
**MACSOLUTIONS**  
[WWW.MACSOLUTIONS.COM](http://WWW.MACSOLUTIONS.COM)



## SAVINGS FOR STUDENTS & TEACHERS

EDUCATIONAL DISCOUNT SUPERSTORE / UP TO 80% OFF

FREE CATALOG 800-699-1836

BBEdit 5.1.1.....	\$79
Coda Finale 2000.....	\$249
Cubase VST 4.1.....	\$199
ElectricImage 3D 2.9.....	\$739
Eye Candy 3.0.1.....	\$79
FileMaker Pro 5.0.....	\$159
Flash 4.0.....	\$99
FreeHand 8.0.....	\$99
HomePage 3.0.....	\$59
HyperStudio 3.2.....	\$119
LightWave 3D 6.0.....	\$889
MacLinkPlus 11 Deluxe.....	\$75
Mask Pro 2.0.....	\$99
Media Cleaner Pro 4.0.....	\$319
Myrmidon 2.1.....	\$39
PhotoTools 3.0.....	\$79
Poser 4.0.....	\$179
RayDream Studio 5.5.....	\$229
Stuffit Deluxe 5.5.....	\$55
TechTool Pro 2.5.....	\$85
Vectorworks 8.5.....	\$339
Virtual PC 3.0.....	\$169
Wacom Intuos 6x8 USB.....	\$285
WordPerfect 3.5.1.....	\$39
Xenofex 1.0.....	\$79



**Dreamweaver 3.0  
Fireworks 3 Studio** \$149  
New Version!



**Final Draft 5**



**Kais Power Tools  
6.0** \$89



**CodeWarrior  
Pro R5** \$119

**(800) 699-1836**

Phone 732-660-8820 • Fax 732-660-8828

\*Not responsible for typographical errors \* Prices subject to change

Visit our website for over 5000 titles!!

**Software Showcase**  
417 Euclid Ave  
Loch Arbour, NJ 07711

**www.softwareshowcase.com**

168 on card or www.macworld.com/getinfo

## ACADEMIC DISCOUNTS on CREATIVE DIGITAL TOOLS



explore our web site!

**www.creationengine.com**

call for a free catalog!

**1.800.431.8713**

- PRODUCT INFO
- ACADEMIC PRICES
- ONLINE ORDERING
- REVIEWS
- TUTORIALS
- ARTWORK



Students, faculty, and schools can save up to 70% on the hottest creative digital software from over sixty companies, including Adobe, Macromedia, MetaCreations, Discreet, Newtek, and Hash.

**CREATION ENGINE, LLC**

## ACADEMIC DISCOUNTS

Super Savings for Students, Teachers, & Schools!

JUST A FEW  
OF OUR  
EVERYDAY  
LOW PRICES!



"Helpful sales people that really know what I'm talking about plus discounted prices... I love you guys!"

— Ashley B.  
Elementary School Teacher

Macromedia Internet Studio

Dreamweaver 3 & Fireworks 3  
ALL FOR ONLY: **\$148**

MetaCreations 3D Suite v4.0

Bryce 4, Poser 4 & Canoma  
ALL FOR ONLY: **\$299**

"Your 'Buy Now, Shop Later' policy makes it easy for me to know I'm always getting the best prices."

— Andrew H.  
University Student

ADAM A+ Bundle	\$129	Electric Image	\$639	Mask Pro	\$99
Boris FX	\$399	Filemaker Pro 5	\$148	Mathematica 4	\$129
Bryce 4	\$139	Fireworks 3	\$98	Office 98	Call!
Canvas 7	\$189	Flash 4	\$98	Painter 6	\$209
Carrara	\$199	FormZ	\$849	Vectorworks 8.5	\$329
Coda Finale 2000	\$199	Freehand 8	\$98	Iomega	Call!
CodeWarrior Pro 5	\$109	KPT 6	\$79	Wacom 6x8	\$284
Director 7	\$329	Lightwave 3D 6	\$799	(PC titles also available)	
Dreamweaver 3	\$98				

Visit AcademicSuperstore.com for online ordering & thousands of other products!

CALL FOR YOUR FREE CATALOG

**1-800-333-8571**

Fax PO's and ID's to 512-450-0263

**www.AcademicSuperstore.com**

**ACADEMIC DISCOUNT  
SUPERSTORE**

168 on card or www.macworld.com/getinfo

## Learn AppleScript



**www.TECSoft.com**  
800-626-4119

Are you a  
student or a  
teacher?  
Great  
discounts on  
this page!

## STUDENTS!

Save up to 75% OFF  
popular software!



- Adobe
- Microsoft
- Discreet
- MicroSoft
- MetaCreations
- Macromedia
- AliasWavefront
- SoftImage
- Autodesk
- Extensis
- Alien Skin
- Digitation
- Symantec
- Corel
- ADAM
- Wacom
- Many More!!

THOUSANDS OF TITLES AVAILABLE!  
**FREE CATALOG!**

Serving students & schools since 1990

**1-800-874-9001**

**JourneyEd**  
Journey Education Marketing

www.JourneyEd.com

174 on card or www.macworld.com/getinfo



## The Easy-Switch

Share your **monitor, mouse, keyboard & USB peripherals** between several Macs (and PCs) with Dr. Bott's **MoniSwitch**.

- Support for both Mac & PC monitors.
- Looks and works great with new G4s!
- Available for 2 or 4 computers at \$139 & \$199.
- Includes all necessary USB and video cables!
- ADB version also available.

Dr. Bott LLC is proud to distribute quality products from Macsense, Griffin Technology, and others including the XRouter, iMate and iBookBag

### Dr. Bott

(503) 452-8101 • (503) 892-2475 fax  
info@drbott.com • www.drbott.com

**Attention Resellers!**  
We're your best source for great Mac stuff!



# MoniSwitch

USB

173 on card or www.macworld.com/getinfo

## Port Short?

# STEALTH Serial Port

Now available for the Power Mac G4 & G3 and iMac

Easily Connects Your Serial Peripherals to the Power Mac G4 & G3 and iMac

Easy to install and use  
Functions like a standard Mac serial port  
Works with LocalTalk, MIDI, all serial printers, modems, digital cameras

Only \$49.95

[www.geethree.com](http://www.geethree.com)



# GeeThree.Com

261 Hamilton Ave, Suite 311 • Palo Alto, California • 94301  
phone 650.328.2359 • fax 650.328.8092 • email info@geethree.com

168 on card or www.macworld.com/getinfo

www.contourdesign.com

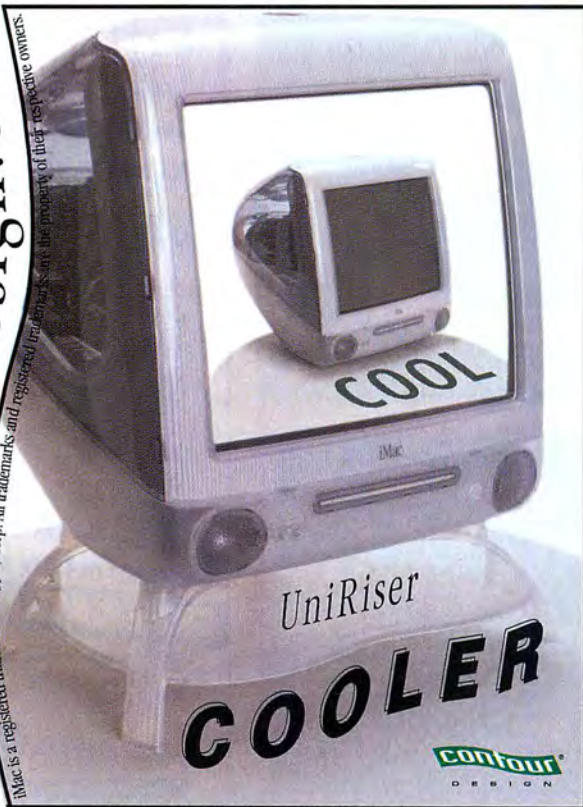

iMac is a registered trademark of Apple, Corp. All trademarks and registered trademarks are the property of their respective owners.

169 on card or www.macworld.com/getinfo

## iView my iMac on a Television

As low as  
**\$139.00**



You teach to make a difference.  
**i•View** will make a difference in the way you teach.

**i•View** FOCUS Enhancements has just introduced the ONLY PC-to-TV video scan converter available for the popular iMac computer! The i•View and i•View Gold from FOCUS turn any television into a large screen computer display. Instead of two or three students hovering around a computer monitor, the entire class can "get the big picture" on a large TV screen.

Enhance the teaching and learning experience by captivating your classroom with eye-catching graphics and annotations. The i•View Gold has the features and functions of the iView, but with a remote for pan, zoom, and freeze. It incorporates TrueScale® image technology to compress the image evenly and clearly without any line dropping.



Call now for a free product guide!  
[www.focusinfo.com](http://www.focusinfo.com)

**FOCUS**  
enhancements  
superior video conversion technology  
888-356-3920

172 on card or www.macworld.com/getinfo



# Remote Control for PowerPoint, QuickTime, DVD, CD, & MP3 Software!

**NEW**



## Digital Media Remote

USB remote control for PowerPoint, DVD, CD, & MP3 software players (\$79)

## USB Twin Serial Adapter

Add 2 Mac serial ports to your USB Mac (\$79)

- For use with tablets, modems, cameras & many printers
- Get two ports for the price of the single port solutions!

**Macworld**



## USB PDA Adapter

Connect Palm organizers to your USB Mac or Win98 PC (\$39)

## USB 4-Port Hub

Connect more USB devices to your USB Mac (\$49)

## Keyspan USB Card

Add 2 USB ports to your PCI PowerMac (\$39)

## SX Pro Serial Card

Add 4 serial ports to your PCI PowerMac (\$179)



"One of the coolest & most convenient gadgets you can purchase" - MacNN, Nov 99



**KEYSPAN** [www.keyspan.com](http://www.keyspan.com)  
(510) 222-0131

170 on card or [www.macworld.com/getinfo](http://www.macworld.com/getinfo)

macally

# mediakey

Macally USB Multimedia Keyboard



macally  
**hub Jr.**



macally  
**mouse Jr.**

CardBus  
FireWire



macally™

Macally is proud to bring you the latest USB and FireWire peripherals for Mac users. Our full line of products are specifically designed for your Mac to improve your productivity. Please visit our website to see what Macally has to offer for all your peripheral needs. We work hard to provide you with the best peripherals for your Mac.

**Call us for dealers near you 1-800-644-1132 or visit us at: [www.macally.com](http://www.macally.com)**

All trademark or registered trademarks are the property of their respective owners

159 on card or [www.macworld.com/getinfo](http://www.macworld.com/getinfo)





## iMate

UNIVERSAL ADB TO USB ADAPTER

Easily Connects Any ADB Device  
To USB-Equipped iMac or PC Computer

The innovative iMate USB to ADB adapter allows users to easily connect their existing ADB peripherals to iMacs, Macs with USB cards, and PCs with USB. The iMate is compatible with any ADB device including mice, keyboards, trackballs, trackpads, hardware dongles, and AppleVision displays. Retail price \$39



80 Fossiers Lane • Nashville, TN 37210  
615.255.0990

info@griffintechnology.com  
www.griffintechnology.com

GRIFFIN  
TECHNOLOGY

The gPort universal serial adapter is the perfect companion for your new blue G3 computer. Designed from the ground up with the G3 in mind it supports every serial device that works on your older Macs.



- Easy to install
- Economical
- Cost Effective

With the new G3s Apple has made a bold move to foster and more universal i/o interfaces. The gPort provides a great transition for people with existing serial equipment. Retail price \$49

gPort  
THE SERIAL SOLUTION

## Protect your iMac with the FLAVOR SAVER™ Security System

For iMac  
& iMac DV

Comes in  
2 flavors



Padlock Security  
Provided by  
Master Lock

Suggested Retail Price \$29.95

Secures  
Internal  
Components  
Too!

Secure-It

18 Maple Court, East Longmeadow, MA 01028, USA  
INTERNET: www.secure-it.com/mw

For more information call 800-451-7592...  
FAX: 413-525-8807 EMAIL: secure-it@secure-it.com

184 on card or www.macworld.com/getInfo

## Digging for ideas?



Get  
**FIRST  
MONTH  
FREE!**  
(promo code:  
macw-3489)

## Bring your IDEAS to Life yourname.com

Fully loaded web site for \$20  
/month\*

- 50 MB disk space
- 2 GB traffic / month
- 10 mailboxes
- Frontpage™ server extensions
- web based control panel, web site statistics, etc.

### NEW! Speciality Packages:

**Media Site:** featuring RealAudio®, RealVideo®, Flash™, Truespeech

**Web Stores:** One Stop Solutions for web store hosting, shopping carts, secure servers, credit card processing.

**30 day money back guarantee!**  
**24x7 toll-free tech support**

For more details visit our web page or call toll free.



NetNation  
Communications Inc.

www.netnation.com  
1-888-277-0000  
Int.: +1(604) 688-8946

Set up fees not included. Prices and features subject to change without notice.  
All trademarks are the property of the respective owners.



## Custom **ULTRA-3 SCSI LVD 160MB/s** Cables - Terminators - Cases

If you want **Ultra SCSI Performance** use our **Teflon Cables & Active Terminators**.

### SCSIVue™ Active Terminator



Four models available with optional Remote LED Pak. These are the finest terminators available, they fix SCSI problems and improve reliability.

- Benefits:**
- Improves SCSI Bus Performance
  - Less Errors; More Reliable Data Transfer
  - Diagnoses Problems • Analyzes Signal Quality
- Features:**
- Active Regulation • Fast 50 & Fast Wide 68
  - Status Indicators • Gold Contacts

### The Book of SCSI \$19.95

- Benefits:**
- Learn the secrets about SCSI
  - Teaches basics thru advanced
- Features:**
- Connector pin outs and details
  - History of different SCSI specifications

### Gold Diagnostic Adapters

- Both 50 pin and 68 pin (all combinations)
- Gender Changer
- Drive Bus Changer (run 68 pin on 50 pin bus)

From: \$49

Styles: 68 Pin Adapter Wide to 50 Pin Narrow  
68 Pin External Adapter to 50 Pin (converts Host Adapter)

- 68 Pin to 50 Pin Centronics or 50 Pin Micro Adapters
- Styles: For Adaptec Ultra Wide Cards  
Adapters with partial termination built in for 68 to 50 converters (converts Host Adapter)

Online Catalog at... [www.scsiopro.com](http://www.scsiopro.com)

### SCSIVue™ Gold Diagnostic Cables

- Benefits:**
- No Loss of Important Data
  - Faster Performance
  - Test Cable Integrity
- Features:**
- Diagnostic Indicators • Large Ferrite Filters
  - Triple Shielding (Unique Design)
  - Double Gold 20u" Plated Connectors
  - Extra Heavy 26 Gauge Wire • 100 Styles in Stock

### Teflon™ 90 Ohm External Cables

- Benefits:**
- Ultra SCSI 160 MB/s operation
  - Fixes Ultra SCSI Cable Problems
- Features:**
- Perfect 90 Ohm Impedance Match
  - Triple Pronged Connector With Gold contacts

### Hot Swap Powered Terminator

Now you can safely remove any SCSI device from a SCSI chain by simply clicking a switch. The Hot Swap Powered Terminator also has an optional Power Supply so that it can supply termination power to portable setups or when termination power is not being supplied.

### Granite Cables Are The Best Because They're Engineered Right.

Granite Cables were designed by SCSI Engineers to be the **Best Cables On The Market**. Everything about them means better performance and higher reliability. Our design incorporates an exclusive shield that protects the Acknowledge and Request lines from noise. Large Ferrite beads are installed on all cables to protect them from static and noise. Every cable incorporates a LED indicator that lets you know it is operating properly. We also use more **GOLD** on every cable. Add to this our impedance matching techniques and you have most of what makes us THE BEST!

### External Ultra SCSI Cases

- Ultra SCSI Custom Teflon Cable Available
- Custom Enclosures in 1 Day for RAID & Arrays



- Options:**
- Ultra LVD Cable Kit
  - Dual Redundant PS
  - Bay Coolers w / Brk
  - Temp Alarm System

### Hot Swap Pull Out Bays

Compatible with all 50 pin & 68 pin SCSI Buses up to Fast SCSI 2. From: \$79

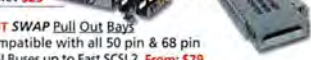

### (LVD)-Teflon™ Internal Cables

- Benefits:**
- Less Errors, Ultimate Performance
  - Silver Wire Improves Signal Quality
- From: \$39**

- Features:**
- Perfect 90 or 132 Ohm Impedance • Custom in 1 Day
  - Triple Pronged Connector - Gold contacts Silver Wire



### Active Digital SCSI Repeater

- Benefits:**
- Models for all SCSI types
  - Fixes SCSI Cable Problems
  - Doubles Cable Length (up to 18')
- From: \$99**
- Features:**
- Active Termination and Signal Purification
  - Ultra Fast Performance for Added Capabilities
  - Diagnostic Capabilities • 30u" Gold Contacts

### SCSI Cable Tester - LED Readout

This Digital SCSI Cable Tester can test all the popular cable styles for opens, shorts, and unreliable operation. Battery powered for easy use anywhere you need it. Three models to choose from:

- 50 pin IDC
- 50 pin Centronics
- 68 pin MicroD

**Special Package of all 3: \$99**

### FREE Technical Support!!!

Available to everyone, customer or not.

Granite **THE SCSI SOLUTION COMPANY** 3101 Whipple Rd. Union City, CA. 94587 Ph: 510-471-6442 Fax 510-471-6267

186 on card or [www.macworld.com/getinfo](http://www.macworld.com/getinfo)

# WHAT DO YOU WANT YOUR SITE TO DO?

## 2 Database Solutions:

HostPro supports a wide range of databases to meet your business needs, from the low cost mySQL, to the popular Access and enterprise-class MS SQL...

- Access • MS SQL • mySQL • mSQL • FoxPro • ASP  
ColdFusion 4.0 • InterDev • Drumbeat 2000

- 3 Multimedia Solutions 1 Platform Solutions 1 E-Commerce Solutions

### STANDARD FEATURES FOR ALL PACKAGES

- Your own domain name ([www.yourdomain.com](http://www.yourdomain.com))
- Free domain name registration
- Both Unix and NT hosting
- 30-day money-back guarantee
- Full support for Microsoft® FrontPage 98™ and Word 2000®
- Default e-mailing capability
- Web control panel for site administration
- Unlimited autoresponders
- Unlimited FTP (24 hours per day)
- Full custom CGI execution capability
- Java™, Javascript, Servlets, Perl, C, C++, SSI & Python
- Access to our vast CGI script library
- Excite® search engine
- Controllable anonymous FTP
- Daily detailed hit analysis
- Access to raw log files
- Daily complete tape backup
- Full-time uninterruptable battery backup
- Shockwave, Quicktime, Flash, Vivo, Emblaze & MP3
- Assistance with script installation



Certified FrontPage Web Presence Provider

Tech Support 24/7

Give your site maximum impact for minimal expense. You owe it to yourself to contact HostPro at:  
**1.888.638.5831**  
[www.hostpro.net](http://www.hostpro.net) • [sales@hostpro.net](mailto:sales@hostpro.net)

**hostpro**  
a micron company  
Your Web-hosting solution provider

NET VALUE	\$19.95
Standard features, plus: • 60MB of Web space • 2GB of traffic/month • 12 e-mail accounts	
NET NT	\$29.95
Standard features, plus: • 60MB of Web space, 2GB traffic/month, 12 e-mail accounts • ASP, ActiveX™, and VB script. Microsoft Access and FoxPro database support • Microsoft Active Server Pages • Microsoft Visual InterDev and Visual Studio • Complete stat reports using WebTrends	
NET PLUS	\$39.95
Standard features, plus: • 100MB of Web space, 3GB traffic/month, 20 e-mail accounts • Advanced ShopPlus Cart (a \$500 value!) Shared secure socket layer (SSL) • PaymentNet and CyberCash™ RealAudio® and RealVideo® G2 • Microsoft NetShow • mSQL and mySQL databases, Cron, PHP 3.0	
NET PRO	\$49.95
Standard features, plus: • 100MB of Web space, 3GB traffic/month, 20 e-mail accounts • Advanced ShopPlus Cart (a \$500 value!) Shared secure socket layer (SSL) • PaymentNet and CyberCash Cold Fusion 4.0 • ASP, ActiveX™, and VB script • Microsoft Access and FoxPro database support • Microsoft Visual InterDev and Visual Studio • Microsoft Active Server Pages • RealAudio, RealVideo & G2 • Microsoft NetShow • Complete stat reports using WebTrends	

230 on card or [www.macworld.com/getinfo](http://www.macworld.com/getinfo)



**Introduced at COMDEX!**  
**UniKeep**



Lightweight & portable • Clear overlay cover for insertable graphics • Full-flip, interchangeable access for up to 10 discs & graphics

**FREE SAMPLE** (US addresses only) with \$4 s/h to P.O. Box 28398, Columbus, OH 43228 or order online at [www.univenture.com](http://www.univenture.com)

**UNIVENTURE**  
DISC PACKAGING & SYSTEMS

Retail distributors call 800 992 8262 for more information. Safety-stress and the Safety-stress logo are registered trademarks of Univenture, Inc. Patents and other pending for UniKeep™. Screen made in the USA and related. Cases made in the USA.

**MEGA**MACS.COM

- Apple 4x/24xCD Drive \$19/\$79
- Norton Utilities 4.02cd only \$9
- G3/400 Zif Upgrade \$225
- 2GB Int SCSI HardDrives \$79
- Ext Zips w/Dsk (ref, 1yr wty) \$59
- LaserWriter Pro 630 \$399
- POLAROID PDC3000 \$599
- PB 3400/5300 Battery \$29

We have over 100 Software titles for \$9.00 ea

**918-664-MACS**(6227)

fax: 918-663-6340 All Prices reflect 3% Cash Discount!

183 on card or [www.macworld.com/getinfo](http://www.macworld.com/getinfo)

**Tendonitis, Carpal Tunnel?**  
**RELIEF GUARANTEED**



- 2-3 Minutes • 2-3 Times A Day
- Medically Proven Relief

[www.armaid.com](http://www.armaid.com)

**Armaid**<sup>TM</sup>

The New Solution for Repetitive Strain

**877.4.ARMAID**



Aeron Chair  
**800-883-9697**  
[www.sittingmachine.com](http://www.sittingmachine.com)

187 on card or [www.macworld.com/getinfo](http://www.macworld.com/getinfo)

**ICN**

1.800.472.4921  
Fax: (310) 445-6611  
Tel: (310) 445-6600  
FAX TOLL FREE/JAPAN: 00-31-114211  
Los Angeles CA 90064

**INNOVATIVE COMPUTER & NETWORKING, INC.**

**GENUINE APPLE CD-ROM**  
**12xCD SCSI \$59**

**MONITORS**

- APPLE Studio 21" .....\$979\*
- APPLE Studio 17" .....\$329\*
- APPLE 1710 Vision 17" ..\$159\*
- APPLE Multiple Scan 15" \$129\*

**G3 & G4 Upgrades**

Available By: Newer Technology  
Sonnet, Mactell & Power Logix

**Apple CD-ROMS & Hard Drives**

- APPLE SCSI CD-ROM Drive 4xCD .....\$89
- APPLE SCSI CD-ROM Drive 12xCD .....\$59
- APPLE SCSI CD-ROM Drive 24xCD .....\$89
- 1GB 3.5" SCSI Hard Drive .....\$75
- 2GB 3.5" SCSI Hard Drive .....\$99
- 4GB 3.5" SCSI Hard Drive .....\$179

**POWER MACS**  
RECONDITIONED

- G4 450 (256MB/27GB/DVD/Zip) .....\$3130
- G4 400 (128MB/20GB/DVD/Zip/Mod) .....\$2190
- G4 350 (64MB/10GB/32XCD/56K/KB) .....\$1479
- G3 350iMAC (32MB/6GB/24XCD/MOD/KB) .....\$939
- G3 450M (128MB/UW9GB/24XCD/KB) .....\$1549
- G3 400M (128MB/12GB/24XCD/KB/ZIP) .....\$1549
- G3 400M (64MB/6GB/DVD/KB) .....\$1475
- G3 300M (64MB/6GB/24XCD/KB) .....\$1290
- G3 266Mhz 32/6GB/CD/KB/SCSI .....\$1190
- G3 233Mhz 32/4GB/CD/KB/SCSI .....\$1090

- 9600 300Mhz 64/4GB/CD/VC/KB \$1795
- 9500 300Mhz 32/2GB/CD/VC/KB \$969
- 9600 200Mhz 64/4GB/CD/VC/KB \$1089
- 9500 132Mhz 32/1GB/CD/VC/KB \$689
- 8600 300 Mhz 32/4GB/CD/KB ..\$1049
- 8600 200 Mhz 32/2GB/CD/KB ...\$969

- 8500 150Mhz 32/2GB/CD/KB .....\$629
- 8500 120Mhz 32/1GB/CD/KB .....\$589
- 7600 120 Mhz 16/1GB/CD/KB \$499
- 7500 100 Mhz 16/500HD/CD/KBS469
- 7300 180 Mhz 16/2GB/CD/KB \$599
- 7200 120 Mhz 16/1GB/CD/KB .....\$319
- 7200 90Mhz 8/500MB/CD/KB .....\$269
- 6500 275Mhz 32/4GB/CD/KB/MOD .....\$749
- 6500 250Mhz 32/4GB/CD/KB/MOD .....\$695

Prices Subject to Change Without Notice • All Prices reflect 3% Cash Discount • \* Refurbished  
ICN Is Not An Authorized Apple Dealer • All Trademarks Are Property Of Their Respective Companies.

**POWERBOOKS & DUOS**  
RECONDITIONED

- G3 400Mhz 64/6GB/DVD/14.1"A/ETH/56K ...\$3290
- G3 333Mhz 64/4GB/24xCD/14.1"A/ETH/56K \$2369
- G3 300Mhz 64/8GB/CD/14.1"A/ETH/56K ...\$2190
- G3 250Mhz 64/4GB/CD/13.1"A/ETH/56K ...\$1690
- G3 233Mhz 32/2GB/CD/ETH/56K .....\$1290
- 3400c 240Mhz 16/3GB/12XCD/Modem/ETH \$1229
- 3400c 200Mhz 16/2GB/6XCD/Modem/ETH \$1099
- 1400c 133Mhz 16/1GB/8xCD .....\$990
- 1400cs 117Mhz 12/750HD ..\$729
- 170 25Mhz 4/40 .....\$179
- 5300ce 117Mhz 32/1GB ...\$639
- 5300c 100Mhz 16/750MB ..\$529
- DUO 2300c 100Mhz 8MB/750/Modem ...\$529
- DUO 280c 33Mhz 4MB/120/Modem .....\$189
- DUO 270c 33Mhz 4MB/120/Modem .....\$189
- PB 520 20Mhz 160-U .....\$269

ICN has the largest inventory of Apple parts, USB & FireWire Peripherals. Please call for prices by Ariston & VST

**POWERMACS (NUBUS)**  
RECONDITIONED

- 8100 110Mhz 16/1GB/CD ...\$490
- 8100 100Mhz 16/700MB/CD \$349
- 8100 80Mhz 16/500MB/CD ..\$249
- 7100 80Mhz 8/250MB/CD ..\$169
- 6100 66Mhz 8/250MB .....\$189

www.icni.com • 1.800.472.4921



# 800-673-MACS

916-652-1880 FAX 916-652-1881 800-673-6227

**SuperMac S900**  
**\$699**  
 G3 Upgradable  
 5 PCI SLOTS  
 PPC 604e 233 Mhz 16/2GB/CD/VD  
 Includes keyboard and mouse

**APPLE ORIGINAL CD ROMs**  
 8X 1200i...\$59.99 External Drives  
 12X 1800i...\$79.99 Add \$39  
 24X 3600i...\$99.99  
 CDROM Drives are Mac OS Bootable and use Apple Original Driver Software  
 Largest Inventory, BEST Prices

**Apple 20" Multiscan**  
**\$499**  
 Trinitron Tube Digital Controls

**SuperMAC C600/240**  
**\$399**  
 NEW PRICE  
 G3 Upgradable  
 PPC 603e 240 Mhz Mini-Tower

**24X BOOTABLE! EXTERNAL CD-ROM**  
**\$109.99**  
 Macintosh Ready! Includes Drive Software

**Apple 17" Multiscan**  
**\$199**  
 Trinitron Tube Digital Controls

**Apple PowerMacs**  
 PM6100 8/230 w/ Mouse **\$149**  
 G3 Upgradable  
 PM7100 8/500 w/ Mouse **\$199**  
 G3 Upgradable

**SCSI Hard Drives**  
 240 Megabyte...\$39.99  
 500 Megabyte...\$59.99  
 1 Gigabyte...\$89.99  
 2 Gigabyte...\$129.99  
 4 Gigabyte...\$199.99  
 9 Gigabyte...\$349.99  
 External Drives w/cables add \$50

**Apple 15AV**  
**\$149**  
 Built in stereo speakers

**PPC 5200-75 8/500/CD (U)**  
 Power PC 603e 75Mhz  
 Built-in-Monitor **\$449**

**PPC 7600-120 16/1.2G/CD (U)**  
 Power PC 604 120Mhz  
 Includes Ethernet **\$499**

**Apple 15AV**  
**\$149**  
 Built in stereo speakers

**PPC 8500-120 16/1.2G/CD (U)**  
 Power PC 604e 120Mhz  
 Includes Ethernet **\$599**

**Motorola 28.8 Modem (N)**  
 OEM Packed Mac Ready Includes Cables **\$29.99**

**Apple 15AV**  
**\$149**  
 Built in stereo speakers

**Quadra 68040 CPU's Mouse (U) from... \$99.99**  
 PM 6100/608/500/CD Mouse (U) ..... 229.99  
 PM 7100/668/1.2G/CD Mouse (U) ..... 349.99  
 Performa 6360 16/1.2G/CD (U) ..... 449.99  
 PM 8500/120 16/1.2G/CD Mouse (U) ..... 649.99  
 PowerCurve 120 16/1GB/CD Mouse (U) ..... 299.99  
 Performa 550 Built-in Monitor Mouse (U) ..... 299.99  
**IMACS All-In-One G3 (U/R) CALL**

**Motorola 28.8 Modem (N)**  
 OEM Packed Mac Ready Includes Cables **\$29.99**

**Apple 15AV**  
**\$149**  
 Built in stereo speakers

**Apple Mouse I, 22.99 Ext Keyboard (N) 29.99**  
**Apple Mouse II 32.99 Gamepad-Macality 29.99**  
**ADB Mouse 19.99 Trackball-Macality 29.99**  
**ADB Mouse 2 button 24.99 PCI to USB 2 Ports 69.99**  
**USB iKey Keyboard 39.99 USB iMouse (N) 29.99**  
**USB iHub 4 port 49.99 USB iBall Trackball 39.99**  
**USB to iPort 39.99 USB to Serial (N) 79.99**

**Motorola 28.8 Modem (N)**  
 OEM Packed Mac Ready Includes Cables **\$29.99**

**Apple 15AV**  
**\$149**  
 Built in stereo speakers

**Laser Toner & Inkjet Cartridges**  
 Top Quality Remanufactured COMPLETE Reference ON-LINE  
 Apple®, Canon®, Epson® and Hewlett-Packard®

**ASANTE 100tx hub liquidation**

**Apple 15AV**  
**\$149**  
 Built in stereo speakers

**EPSON Stylus Color 740**  
 11x17" 2400 dpi  
 Quality color & laser quality black ink  
 Up to 8 pages black & 9 pages color  
 USB & Serial  
 Refurbished  
**\$129**

**MacOS 9.0**  
**\$69.99**  
 Retail Packed, CDROM

**ix3D Ultimate Rez**  
**\$69.99**  
 8MB S/G RAM, PCI Video Card  
 A blast of pure 128-bit graphics power!

**LW 8500 (R)**  
**\$999**  
 Workgroup Printer

**MacOS 8.1 \$29.99**  
**MacOS 8.5 \$59.99**  
 OEM/RETAIL INSTALL

**GAME ROCKET**  
**\$99.99**  
 16MB S/G RAM  
 PCI Video Card  
 30ix VooDoo Bananas Chip Set  
 for the hottest game play possible!

All products are sold with a 90 Day PowerON warranty  
 All Sales Final. No Cash Refunds Given  
 \*All Prices include 3% cash discount  
 †Prices subject to change without notice  
 ‡Package sold by weight, not by volume  
 Gov't & School PO's Accepted  
 All brand or product names are registered trademarks of their respective holders and are respectfully acknowledged.

**PowerON Computer Services**  
 Mon-Fri 7-6, Sat 10-5  
 4323 Anthony Ct. #1 Rocklin, CA. 95677  
 E-Mail: Sales@poweron.com

[www.poweron.com](http://www.poweron.com) Check Out Our Complete Inventory Online

199 on card or [www.macworld.com/getinfo](http://www.macworld.com/getinfo)

HELPING MAC USERS SINCE 1987  
 Authorized Dealer **MacBYTE**  
**WE'LL BUY YOUR USED MAC!**  
**PC100** for Yosemite G3/G4 and New iMac 64 mb \$ 72  
 128 mb \$ 143  
**DIMMs** for 72/73/7500, 85/8600, 95-9500 64 mb \$ 99  
 128 mb \$ 167  
**iMac RAM** for 233/266, 333 Mhz 64 mb \$ 74  
 128 mb \$ 147  
[www.computeraddict.com](http://www.computeraddict.com)  
**800-432-2983**  
 1024 Harding Ave., #203, Venice, CA  
 Fax: 310/448-4494

**WWW ONERAM.COM**

**Mac POWER**  
 Sales & Service, Inc.  
**BUY • SELL • TRADE**  
**UPGRADE • REPAIR**  
**New • Used • Refurbished**  
 • PowerBooks • Monitors  
 • PowerMacs • Printers  
 • Performas • Peripherals  
 • Quadras • Ram  
 • MacII-LC • Parts  
[www.macpowerinc.com](http://www.macpowerinc.com)  
**888-275-POWER**  
 Fax: 408-448-6132  
 San Jose, California, 95123

[www.mac-pro.com](http://www.mac-pro.com)  
 Systems & Software Since 1988  
 Buy • Sell • Upgrade • Repair • New • Used  
**We have It All In Stock!**  
 • iMac, G3, G4  
 • PowerBooks  
**Everything Mac!**  
 Any Ad is a Mac Pro Ad  
**800-525-3888**  
[sales@mac-pro.com](mailto:sales@mac-pro.com) Fax 408-369-1205  
 193 on card or [www.macworld.com/getinfo](http://www.macworld.com/getinfo)

MR Mac-Res-Q  
 Voice: 925-689-9488 Fax: 925-689-9487  
**MacResQ**  
**Memory Special! ONLY \$1 per MB**  
 Good for any beige G3 or PowerMac CPU purchased from MRQ. Must be installed using 8mb or 16mb. Good for up to 64mb. \$25 installation fee applies.  
 Example: 32 MB of Memory = \$32, 64 MB = \$64 PLUS \$25 install.  
**Bundle Special!**  
 PM 7500/100 32/1 Gig/4xCD + Apple 20" Multi-Scan + keyboard & mouse **\$799**  
**CD Roms**  
**INTERNAL CD'S**  
 • Apple 2x.....\$49  
 • Apple 8x.....\$69  
 • Apple 12x.....\$79  
 • Apple 24x.....\$99  
 • Sony 12x.....\$69  
 • external case.....\$49  
 • internal kit.....\$25  
**POWERBOOK CD'S**  
 • Apple 6x: PB 3400..\$99  
**Monitors**  
 • Magnavox 14".....\$99  
 • Apple 21" Color Display....\$399  
 • LaCie 19T Multi-Scan.....\$349  
 • LaCie 21 Blue Multi-Scan...\$649  
 • LaCie 22 Blue Multi-Scan...\$799  
**Software**  
 • Mac OS 8.5.....\$49  
 • Norton 4.0.....\$29  
 • Mac OS 8.1.....\$29  
 • ClarisWorks 5.0.....\$29  
 (All software on CD rom)  
 • Visit our website for our FULL LINE of MAC Software titles!  
**Hard Drives**  
 • internal •  
 • 80 mb SCSI.....\$29  
 • 2.1 Gig SCSI....\$119  
 • 4.3 Gig SCSI....\$199  
 • 4.3 Gig IDE.....\$129  
 • 6.4 Gig IDE.....\$139  
 • external case: \$29  
**Floppies**  
 • 661-0474: \$49 (auto)  
 • 661-0121: \$59 (manual)  
 • 661-1390: \$59 (G3)  
 • 661-1651: \$89 (PB 1xx)  
 • 661-0994: \$99 (PB 5xx)  
 • Duo External: \$99  
**888-447-3728**  
**www.macresq.com**  
 Order On-line !! Secured Order Form!!  
 191 on card or [www.macworld.com/getinfo](http://www.macworld.com/getinfo)







**DIGITAL PREPRESS SYSTEMS**

## Specializing in Rebuild Imagesetters

(714) 892-5290 Fax: (714) 892-4361

**ALL MAKES & MODELS Complete Prepress Systems**

e-mail: prepress77@hotmail.com  
P.O. BOX 4381, Huntington Beach, CA 92605

#### PLATEMAKING SYSTEM



Rebuild-Digital Platemaking Imagesetter, PS RIP Processor, Densitometer, Calibration Software 150 LPI. From **\$10,000**

#### SAPHIR SCANNERS



**FACTORY REFURB:** 1 yr. Wnty, Saphir, Saphir Ultra, Ultra 2, Hi-Res, Opal Lino-color from **\$945**

#### HARLEQUIN RIP

Software, PS Level 3 MAC OS, WIN 95, WIN NT Compatible for most Imagesetters **\$4,995**

#### PROCESS COLOR SYSTEM



**INCLUDES:** G3-MAC, Scanner, RIP, Imagesetter, Proof Printer, Processor & Software **\$22,500**

#### SILKSCREENING



**IMAGESETTER:** Agfa or Linotype 18" wide Hi-Quality Film - Pos Separations **\$15,000**

#### HOWTEK DRUM CANNER



**D4000:** 4000 dpi, 3.9 Dyn Range, 6 bit, CMYK, RGB, Factory Refurb, Desktop Size **\$9,950**

#### SCITEX DOLEV



**SCITEX DOLEV Drum Imagesetter:** 200 - 2Up **\$12,000** 400 - 4Up **\$18,000** 800 - 8Up **CALL**

#### HI-QUALITY/LOW COST DIGITAL PROOFING



**EPSON 5000 with Harlequin RIP... \$4800** Faster and Better than the Fiery RIP. Lower cost - Great add-on for current Harlequin RIP users.

#### BEST OF THE REST

Macintosh G3, PC Pentiums, All Prepress Software, File Servers, Networking Hubs & Switches, Color Proofing Printers & Match Print Equipment

## Save on Reconditioned Macs & Peripherals from DataTech

#### MONITORS

- 14" Apple Color Plus..... \$99
- 14" Apple Trinitron..... \$129
- 14" Apple MultiScan..... \$129
- 15" Apple MultiScan..... \$149
- 17" ColorSync MultiScan..... \$229
- 20" Apple MultiScan..... \$399
- 21" Radius PrecisionView..... \$399

Visit our web site for other products. Ask about the 6-month warranty. VISA & MasterCard accepted.



#### RECONDITIONED G3s

- Beige DT/233 32/4G/CD..... \$1049
- Beige DT/266 32/4G/CD..... \$1099
- Beige MT/266 32/4G/CD..... \$1149
- Beige MT/300 64/6G/CD..... \$1299

#### POWERBOOKS

- 520c 12/160/Mod..... \$249
- 540c 12/320/Mod..... \$349
- 5300cs 16/750..... \$399
- 5300c 16/750..... \$449

#### POWERMACS

- 6100/60 8/230/CD..... \$149
- 7200/75 24/500/CD..... \$249
- 7200/90 24/500/CD..... \$279
- 7200/120 24/500/CD..... \$319
- 7500/100 24/1G/CD..... \$449
- 7600/120 24/1G/CD..... \$499
- 7600/132 24/1G/CD..... \$499
- 8500/120 32/2G/CD..... \$549
- 9500/132 32/2G/CD..... \$649

All CPUs include mouse

#### TO ORDER CALL

**1-800-281-3661**

#### DataTech

REMARKETING, INC.  
Tel: 615-860-4422  
Fax-On-Demand: 615-860-0109  
Fax: 615-860-0390  
Web: www.datatech-rmk.com  
471 Myatt Dr., Madison, TN 37115

Corporate names and trademarks are the property of their respective owners.

## 1-800-533-9005

We are open Mon-Sat, 9am-6pm

Fax Bids: (310) 475-7744 or email at SALES@COMPU-AMERICA.COM  
10435 Santa Monica Blvd., Los Angeles, CA 90025

### Check out our Web!

[WWW.COMPU-AMERICA.COM](http://WWW.COMPU-AMERICA.COM)

Government, University and Fortune 1000 P.O.'s are welcome!  
Business Leasing is Available!  
International Orders Please call tel: (310) 446-1771

#### POWERMACS!

Starting at **\$599**



- G4/450MT... 256/27G/DVD/ZIP... \$1499
- G4/400MT... 128/20G/DVD/ZIP/56K... \$2299
- G4/400MT... 64/10G/CD/56K... \$1499
- G4/350MT... 64/10G/DVD/56K... \$1479
- G4/350MT... 64/10G/CD/56K... \$1379
- G3/450MT... 128/9GW/24XCD... \$1849
- G3/400MT... 128/12.1G/24XCD/ZIP... \$1499
- G3/300MT... 64/66G/24XCD/ZIP... \$1279
- G3/300MT... 64/66G/24XCD... \$1199
- G3/400MT... 128/9GW/24XCD/SCSI... \$1599
- G3/350MT... 64/66G/DVD... CALL
- G3/333MT... 128/9GW/24X... \$1699\*
- G3/300MT... 64/4G/24XCD... \$1499\*
- G3/266MT... 128/4GW/24X... \$1499\*
- G3/266MT... 32/6G/24X/ZIP... \$1399\*
- G3/266MT... 32/4G/24XCD... \$1099\*
- G3/233MT... 32/4G/24X/MODEM... CALL
- G3/300MT... 32/4G/24XCD... CALL
- 9600/350... 64/4G/24XCD... CALL
- 9600/300... 64/4G/24XCD... CALL
- 4400/200... 32/2G/CD/DOS CARD... CALL

#### WORKGROUP SERVERS

- G4/350... 128/20G/DVD/SHARE... \$2399
- G3/450... 256/2-9G/24X/SHARE... \$2699
- G3/400... 256/2-9G/24X/SHARE... \$2399
- G3/300... 64/6G/24X/SHARE... \$1799

#### I-MACS

Starting at **\$899**

- I-MAC G3/400 128/13G/DVD/56K/VID EDIT 1479
- I-MAC G3/400 64/10G/DVD/56K/CID EDIT 1269
- I-MAC G3/350 64/6G/24XCD/56K... \$969
- I-MAC G3/333 32/6G/24XCD/56K... \$749
- I-MAC G3/233 32/4G/24XCD/56K... \$649\*

#### POWERBOOKS

Starting at **\$599**

- 3400C/240... 16/3G/CD/MOD... \$1199\*
- 3400C/200... 16/2G/CD/MOD... \$1099\*
- 3400C/180... 16/1G/CD/MOD... \$999\*
- 2400C/180... 16/2G/CD... \$1199\*
- 1400C/166... 16/2G/CD... \$1099\*
- 1400C/133... 16/1G/CD... \$999\*
- 1400C/117... 16/1G/14.4MODEM... \$999\*
- 5300CS/100... 8/500... \$499\*

#### NEW G3 I-BOOK!

Starting at **\$1099**



- I-BOOK G3/300 32/3.2G/CD/12.1TF/56K... \$1449
- G3/233... 32/2G/20X/12.15TN/56K... \$1099
- G3/250... 32/4G/20X/13.3TF/56K... CALL
- G3/300... 64/8G/DVD/14.1TF/56K... CALL
- G3/266... 64/4G/20X/14.1TF/56K... CALL
- G3/300... 64/8G/DVD/14.1TF/56K... CALL
- G3/333(NEW)64/4G/24X/14.1TF/56K... \$2199
- G3/400(NEW) 64/6G/DVD/14.1TF/56K/3099

#### SONY

Starting at **\$199**

- Sony E100/E200... \$199/349
- Sony G200/G400/G500... \$399/649/1049
- Sony S20G5... \$899
- Sony F-400/F-500... \$699/1699
- Sony L-133/L-150/L-181... CALL
- Sony PRESANTION W7000/W9000... CALL
- Sony MAVICA FD73/FD83/FD91... CALL/629/799

#### ViewSonic®

Starting at **\$134**



- Q41 14"..... \$129
- Q51/Q55 15"..... \$159/169
- P701/Q95..... \$229/389
- E771/E773/E790..... \$229/279/399
- G775/G773..... \$389/309
- G775/G579..... \$339/439
- G771/G773..... \$329/309
- P771/P775..... \$469/429
- P5790/P790..... \$899/529
- P775/P795..... \$349/689
- P810/P813..... \$829/899
- P815/P817..... \$859/1379
- VIEWPANEL VPA145/VPD150..... \$899/949
- VIEWPANEL VP151/VPA150..... \$949/1029
- VIEWPANEL VGI50/VGI80... CALL/2999
- VIEWPANEL VP181... CALL

#### RASTEROPS

- Superscan MC-801HR/1600X1200... \$699
- Superscan MC-6415... \$429
- Superscan MC-7515... \$599
- Superscan MC-8135... \$999
- Superscan MC-8115... \$969

#### EPSON®

Starting at **\$199**



- STYLUS COLOR 900/900G/900N... \$299/369/529
- STYLUS COLOR 740/750/760... \$199/229/239
- STYLUS COLOR Photo-1200... \$449
- STYLUS PRO-XL (11X17)LARGE FORMAT... \$199
- STYLUS COLOR 1520... \$449
- STYLUS COLOR 3000/5000... \$1099/2329
- LASER EPL-5700... \$379
- PERFECTION 1200U/1200S... \$229/279
- 4000N/4000T/4050N... \$999/1099/1149
- 4050TN/2100M/2100TN... \$1299/679/829
- 5000/5000N/5000GN... \$1249/1694/2129

#### UMAX®

Starting at **\$99**

- VISTA Astra 6105-P... \$99
- VISTA Astra 1200/1220... \$149/159
- VISTA Astra 2000U USB... \$129
- VISTA Astra 2400S... \$299
- POWERLOOK II... \$779

#### intuos

Starting at **\$99**



- INTUOS 4 X 5 (USB)... \$129
- INTUOS 6 X 8... \$299
- INTUOS 9 X 12... \$399
- INTUOS 12 X 12... CALL

#### iomega

Starting at **\$79**



- ZIP DRIVE 250 MB EXT (SCSI)... \$149
- ZIP DRIVE 100 MB INT(G-3)... \$99
- ZIP DRIVE 100 MB EXT (USB)... \$119
- JAZZ DRIVE 2 GIG EXT/INT... \$299/299
- ZIP 100MS CART (10 PACK)... \$85
- ZIP DRIVE 1 GIG... \$79
- JAZZ CART 2 GIG... \$79

#### GLOBAL VILLAGE

- Global Village Plat 56K EXT... \$99
- Global Village PLAT 56K INTERNAL(G-3)... \$79
- Global Village PLAT 56K EXT (USB)... \$129
- Global Village 56.6 PCMCIA... \$139
- DAYNA PCMCIA 56KMOD/10BT ETHERNET... \$149

## YOUR #1 COMPUTER SUPERSTORE!



All prices are cash discounted. "\*" denotes a refurbished product. Not responsible for typos. Apple, the Apple logo, GeoPort, HyperCard, ImageWriter, LaserWriter, Mac, Mac OS logo, Macintosh, MessagePad, Newton, OpenDoc, PowerMacintosh, PowerBook, QuickTake, QuickTime, QuickTime Logo and StyleWriter are trademarks of Apple Computer, Inc., registered in the U.S. and other countries. All other names & logos are trademarks by their respective owners. We are Not Apple Authorized.



# MCE POWERBOOK PRODUCTS

secure online ordering

[www.powerbook1.com](http://www.powerbook1.com)

## CUSTOM POWERBOOK CONFIGURATIONS



### Apple PowerBook G3 Series

- 333MHz/512K cache
- **MobileStor 12GB HD**
- 14.1" Display
- 64MB RAM
- 2 USB Ports
- FireWire ready\*
- 24X max CD-ROM



**\$2849**

w/18GB HD...\$2999

### Apple PowerBook G3 Series

- 400MHz/1MB cache
- **MobileStor 12GB HD**
- 14.1" Display
- 64MB RAM
- 2 USB Ports
- FireWire ready\*
- DVD-ROM



**\$3749**

w/18GB HD...\$3899

### Apple iBook *Tangerine* or *Blueberry*

- 300MHz/512KB cache
- **MobileStor 6GB HD**
- 12.1" Display
- 32MB RAM
- 1 USB Port
- 6 hour max battery
- 24X max CD-ROM



**\$1799**

w/12GB HD...\$1999

Don't forget to add more memory!

\* requires optional FireWire PC Card

## ASK ABOUT OTHER CUSTOM CONFIGURATIONS & SOLUTIONS!



• Wireless networking w/ optional AirPort card and base. AirPort card...\$99 Base...\$295

## COMPLETE POWERBOOK STORAGE SOLUTIONS



### MCE MobileStor Internal Hard Drive Upgrades

For use in iBook, PB G3 Series, G3, 3400, 2400, 1400, 5300, 190, & Duo 2300

<b>MobileStor 6400</b>	6.4GB	3-yr wty	<b>\$249</b>
<b>MobileStor 12G</b>	12GB	3-yr wty	<b>\$399</b>
<b>MobileStor 18G</b>	18GB	3-yr wty	<b>\$599</b>
<b>MobileStor 25G</b>	25GB	3-yr wty	<b>\$729</b>

Included **FREE** in every MCE MobileStor hard drive upgrade solution is the **complete MCE PowerBook Hard Drive Installation Kit** which includes an illustrated installation manual, and all of the appropriate tools and brackets needed for the proper installation of your new MCE MobileStor hard drive kit.

### MCE Xcarét Pro Media Bay Hard Drives

- Ultra Fast! • Hot Swappable
- Compact • Protective Carrying Case
- Kit is perfect for your old internal PB drive!

Perfect for audio & video recording!

18GB	12GB	6GB	Kit
<b>\$799</b>	<b>\$599</b>	<b>\$399</b>	<b>\$149</b>

\* See web site for details.

### MCE DataShuttle PC Card Hard Drives

- Completely Portable
- Hot Swappable • Boots your PB\*
- Carrying Case • Powered by PC Card Slot!
- Kit is perfect for your old internal PB drive

18GB	12GB	6GB	Kit
<b>\$749</b>	<b>\$499</b>	<b>\$349</b>	<b>\$129</b>

\* Cannot boot PowerBook G3 Series 1999

### MCE CardBus Upgrade Service

for PB 2400 & 3400/G3

opens up the possibilities for **USB, FireWire, 10/100 Ethernet, expanded Video**

See website for details!

### TURN YOUR POWERBOOK OR IBOOK INTO A VIDEO POWERHOUSE!

**CapSure Card \$119**

- Type 2 PC Card • Import movies or stills through S-Video or Composite • Full-Motion (up to 30fps) preview at up to 1024x768

**Kritter USB Camera \$119** (Blue, Orange, Black, or Ice)

**CapSure/Kritter SV BUNDLE DEAL \$239**

**Kritter SV Camera \$139** (Includes CapSure Card)

### newer tech

**FireWire 2 Go CardBus PC Card \$149** Connect to your DV camera!

**BookEndz Dock for G3 Series-99 \$199** Connect to all of your peripherals in an instant!

### RATOC Systems

High-speed PC Card adapters for audio/video data transfer on your PowerBook!

**CBFW2 FireWire CardBus PC Card \$149**

**CB31PB Ultra SCSI CardBus PC Card \$149**

**CB32PB UltraWide SCSI CardBus PC Card \$259**

### WORLD'S SMALLEST POWERBOOK AC ADAPTER!

FOR IBOOK, PB G3, 3400, 2400, 1400 & 2300

SMALLER THAN APPLE'S SMALLEST ADAPTER!!

only **\$85**

Save space and weight in your carrying case!

### MADSONLINE

**PowerBook Auto/Air Adapter \$80** charges PB in the car or plane!

**PowerBook G3 Series Carrying Cases**

Slimline Case...\$99

Productivity Case...\$139

### VST TECHNOLOGIES

**FireWire 18GB Portable Hard Drive \$949** See web site for BUNDLE deals!

**USB 6GB Portable Hard Drive \$399** Blueberry, Tangerine, or Black

**Zip Drive PB G3 Series/3400/1400 \$209/\$219/\$209**

**Li-Ion Battery, Charger & Adapter PB G3 Series 99 \$299**

**DVD-ROM Kit for PowerBook G3 Series 99/333MHz \$399**

### Apple Computer

High-Capacity Li-Ion Batteries!

**PowerBook G3 Series 99 \$129**

**PowerBook 2400 \$249**

### macally

**iMouse Jr. \$79** USB for iBook

**CardBus to USB Adapter \$29**

### Century

**USB CD-RW Drive \$399** (4x24x20x1)

Ultra-Compact & Portable!

### Kensington

**Notebook MicroSaver Security System \$43**

### PowerBook Memory Upgrades

See web site for latest pricing!!

### Port Media Bay Accessory Pouch \$19

Convenient protection for all media bay devices!

### MCE USB Floppy-Drive \$69

Perfect for iBook or PowerBook!

30 Hughes Suite 203 • Irvine, CA • 92618  
 Visa / MC / AmEx / Discover / P.O.'s

**1-800-5000-MAC • 949-458-0800 • fax 949-458-1803**

229 on card or [www.macworld.com/getinfo](http://www.macworld.com/getinfo)



# CALL THE MAC EXPERTS!

Your one-stop source for everything Macintosh®—over 30,000 items on sale at better than mail order prices!  
 “PowerMax—where we still believe a friendly, knowledgeable voice and good service mean something.”

## Huge Software Blowout! - Starting at \$5.00!!

US Atlas/Space Shuttle Bundle ...\$5.00	Microsoft Office 4.2.1 .....\$88.00
Mac OS 7.6 OEM CD .....\$28.00	Word 98, Excel 98, PwrPoint...\$229.00
Mac OS 8.1 OEM CD .....\$28.00	Adobe InDesign Comp. Upgr...\$299.00
Mac OS 9 Full Retail...\$59.00 or \$79.00	Adobe Illustrator 8.0 CD .....\$288.00
Norton Antivirus 5.0 CD .....\$19.00	Adobe PhotoShop 5.5 CD .....\$488.00
Norton Utilities 4.0 CD .....\$19.00	Toast 3.8 for Mac .....\$29.00
Claris eMallier 2.0 .....\$29.00	Tomb Raider II .....\$45.00
Panzer General Game .....\$5.00	Digital Origin Edit DV .....\$519.00



**FREE  
PAPERPORT  
SCANNER  
WITH EVERY  
USED MAC!\***

One of the great things about Macintosh® is how even old Macs still offer tremendous value. PowerMax offers a HUGE selection of Macs at super prices, complete with warranty and the excellent support of our Mac Experts. For the best in everything Mac, call PowerMax!

\*This promotion is designed to call attention to our huge inventory of pre-owned Macs. Only while supplies last. Free scanner must be requested at the time of your order.

## Every Type of Mac® Imaginable!



- Professionally bench-tested Macs with warranties at low, low pricing.
- New models available every day.
- We carry 'em all, but our used and refurbished Macs often offer better expansion, built-ins, upgradability and price/performance.

These are just a few of the pre-owned and refurbished Macs we have as of press time. See our web site for complete descriptions and the latest list.

<b>Pre-owned Macs w/warranty!</b>	<b>Factory Refurbished &amp; New Discontinued</b>
Performa 6116 40/700/CD .....\$199	iMac G3/233 32/4/24x CD rev B ..\$699
7100/66 24/500/CD .....\$239	5900 16/3 Gb/CD-6 PCI Slot .....\$739
PowerBook 5300GS 8/500 .....\$288	iMac G3/266 32/6/24x CD .....\$749
7200/120 8/1.2/CD .....\$309	iMac G3/333 32/6/24x CD .....\$799
PowerCurve 120 16/1 Gb/CD .....\$388	iMac G3/400 Graphite 128/136 G.....\$1349
StarMax 3000/200 32/3/CD .....\$429	Bl/Wh G3/350 64/6 Gb/CD/AV...\$1288
7500/100 32/750/CD .....\$459	Open Box G4/350 64/10/DVD...\$1449
7600/120 16/1 Gb/CD .....\$599	Beige G3/300 64/8/CD/AV .....\$1499
PowerBook 1400GS/166 16/1.3 .....\$599	Bl/Wh G3/450 128/9 UW/CD...\$1749
iMac 233/32/4/CD .....\$619	Bl/Wh G3/233 32/2 Gb/CD .....\$1888
Beige G3's, Blue & White G3's & more!	

Literally over 150 different models! And so many more—call today!

**Ref. Epson Photo 700 Sale!**  
6 color serial printer at an incredible price!

**Hook up a digital camera to your new iMac DV!**

Canon Ultra ..\$888	Canon Elura ..\$1399
Canon XL1.....Call!	Sony Mavica ..\$899

## Why PowerMax is Special

- **We Do Not Use Voice Mail** – How many times have you tried to get a hold of a reseller or manufacturer, whether for sales or tech support, and found your contact buried behind an automated voice mail system? We don't use voice mail for anyone in the company – and never plan to.
- **Choices** – 800 number, internet site, email, fax, even in person at one of our Northwest locations. Many internet resellers don't even publish an 800 number.
- **Selection and Price** – Over 30,000 separate software and hardware items at nationally competitive prices.
- **Personalities** – Only pleasant, intelligent people work for PowerMax. Sometimes we may be a little crazy, but we're great people to get to know if you're living in a Mac world.

## Hard Drives, Displays & More!

PowerMax 17" 720T Trinitron® Display w/5 year warranty.....	\$329
25mm dp with max resolution of 1600x1280—the highest quality Trinitron® made!	
Gravis Firebird Deluxe ADB joystick .....	\$39
Refurbished Sony 6x 4x 2x CDRW USB Drive .....	\$219
Internal LaCie 3 Gb SCSI drive- new (add \$49 for external case) .....	\$149
External LaCie 4 Gb 7200 RPM Seagate drive- factory refurbished .....	\$199
Hewlett Packard Deskjet 810C.....	\$155
NEC CS500 15" Display with Harmon & Kardon Speakers .....	\$139



**iMac™  
iXtravaganza!**  
Ask us how we can have every model iMac ever made in stock at one time!



We'll take your Mac OS computer in trade toward the purchase of new product. Call one of our expert Mac consultants for full details!

**POWER MAX™**  
Knowledge is Power

**800-613-2072**

Local: (503) 624-1827 • Fax (503) 624-1635  
email: sales@powermax.com

Prices subject to change without notice. Prices reflect cash discount. Credit card orders strictly verified against fraudulent use. With use of credit card as payment customer acknowledges that some products are subject to final sale. Many prices are limited to stock on hand. All brand or product names are registered trademarks of their respective holders.

**WWW.POWERMAX.COM**

- The latest prices and close-out product lists
- Order on-line or call one of our expert consultants
- Experts at locating hard to find items or parts.
- Downloadable software on line! One click for hundreds of the latest award-winning titles!



- Personal Financing • Fast P.O. Approvals
- Business Leasing • Extended Warranties



Graphite G4s DV iMacs™ iBooks™ PowerBooks® Blue & White G3's Beige G3's Software

**APPLEMUGSTORE.COM**  
WHERE MAC FANATICS SHOP!



Macintosh User Group members enjoy access to a very special Apple-sponsored web site featuring super deals on the latest Apple products as well as factory refurbished and discontinued Macs, and much more! Not a member? Find out how you can get these great deals by calling PowerMax at 800-689-8191.



**www.applemugstore.com**



The MUG Store. A cooperative venture between Apple and PowerMax to bring MUG members exclusive deals on the latest Mac® products and special offers on discontinued and factory refurbished computers.

PowerMax is a division of Computer Stores NW, Corvallis, OR.



# MacWorks 800-482-2705

e-mail: sales@macworks.com

Voice 913.599.6227 • Fax 913.599.6111 • 9am-6pm Mon-Fri CST  
Prices Subject to Change • Visa/MasterCard/AmEx  
We ship FedEx • 15% minimum restocking fee on all returns

### Apple/Motorola ZIF Upgrade Cards

- Brand New, 2-Year Warranty
- Upgrades G3 desktop/minitower
- Upgrades PCI PowerMacs with an XLR8 CarrierZIF Card
- \$20 trade-in your old (working) ZIF or 604e card



G3/333, 1MB \$179<sup>99</sup> w/XLR8 CarrierZIF \$309<sup>98</sup>  
G3/400, 1MB \$359<sup>99</sup> w/XLR8 CarrierZIF \$489<sup>98</sup>

### Performa 6400/180

- 16/1 6GB/8x/28.8
- Upgrade to Sony 12x CD at no extra charge!
- Used, 30-day Warranty



ONLY \$479<sup>99</sup>

### PM G3/266 All-In-One

- 32/4GB/24x/2ip, 15" built-in display
- PCI, SCSI, serial, ADB, Int. floppy & Zip

ONLY \$1299<sup>99</sup>

### PowerMac Bundles

Includes keyboard, mouse, GeoPort modem. Upgrade any bundled CD to a Sony 12x FREE!

7600/132 16/1 2GB/4x/17" \$799<sup>99</sup>  
6400/180 16/1 6GB/8x/17" \$649<sup>99</sup>  
7100/80 16/200/2x/17" \$599<sup>99</sup>  
7100/66 24/200/2x/17" \$499<sup>99</sup>  
6100/66 8/160/13" RGB\*\* \$249<sup>99</sup>

\*\*Add a Sony 12x CD to this bundle for \$39.99

### Sony 12x CD-ROM

- New, Internal SCSI
- MacOS bootable
- Uses Apple Mounting Kits (\$25)
- 90-day warranty



ONLY \$69<sup>99</sup>  
Panasonic 4x CD-ROM \$29<sup>99</sup>  
• w/CR-504-L  
• New, Internal SCSI

### RocketFire Upgrades

Brand New FireWire & USB Accessories!  
1-Year Warranty



6-Port FireWire Hub \$299<sup>99</sup>  
4-Port FireWire/USB PCI Card \$179<sup>99</sup>  
1-Port FireWire PC Card \$149<sup>99</sup>  
2-Port FireWire PCI Card \$139<sup>99</sup>

www.macworks.com

201 on card or www.macworld.com/getinfo

## MacMart

Systems & Peripherals  
www.macmart.com

### PRINTERS/SCANNERS/CAMERAS

Agfa 1212U/E/Photo 780C \$89 / \$189  
Epson Stylus 740 / 750 \$145 / \$229  
Epson 2500 USB Copier-Scanner & Printer \$429  
Epson 800 Exec. / 836XL \$599 / \$2159  
Epson Stylus 1520 / 3000 \$459 / \$1149  
HP DJ 810C USB / 830C USB \$159 / \$199  
HP LaserJet 2100M / 2100TN \$759 / \$965  
Microtek X6EL / IV / 35T+ \$139 / \$539 / \$449  
Nikon CoolPix 800 / 950 \$619 / \$869  
Tektronix Color Laser 740 / 840 \$1849 / \$2345  
Umax 2000U / Powerlook III \$115 / \$799

• Brand Names are Trademarked with their respective holders • Prices listed are COD • Price & Availability Subject To Change

### POWERBOOKS

Call Us For New Powerbook Models

iBook 300 12.1" 32 - 3.1 CD-56K \$1499  
G3/333 14.1" 64-4GB-CD-56K \$1999  
G3/400 14.1" 64-6GB-DVD-56K \$2989  
VST PowerBook G3 Zip Drive \$189

### VIDEO / DISPLAYS

Apple 17" Studio Display \$479  
Apple 15" Flat Panel \$1229  
Hitachi 17" / 19" .22 DPI 1600x1200 \$329 / \$489  
KDS 17" / 19" .26 DPI 1600x1200 \$249 / \$359  
MiroMotion DC30 + w/Premiere 5.1 \$649  
Sony 17" 210GS / 19" 420GS \$329 / \$559  
Sony 19" G400 / 21" 500PS \$659 / \$1099  
Viewsonic 17" .27 DPI 1280x1024 \$227  
Viewsonic 17" .26 DPI / w/USB \$297 / \$329  
Viewsonic 19" .26 DPI 1600x1200 \$389

### POWERMACS

iMac/350 64MB - 6GB - CD-56K \$969  
G4/350 64 MEG - 10GB-DVD-56K \$1499  
G4/400 128-20GB-DVD-ZIP-56K \$2345  
G4/450 256-27GB-DVD/RAM-ZIP \$3295

### SYSTEM BUNDLES

Check Our Web Site For More Specials

G4/350 128 - 10GB-DVD-56K \$1689  
Iomega Zip & SCSI Card \$1965  
G3/350 128-10GB-DVD-56K Mdm \$1965  
Zip Drive & Microsoft Office 98 \$2999  
G4/400 256-20GB-DVD-Zip-56K \$2999  
17" .25 Display, SCSI Card, Epson Stylus 750 \$4129  
G4/450 256-27GB-DVD-56K-ZIP \$4129  
17" Studio Display, PhotoShop 5.5

Contact Us For Unlisted Products

### GUARANTEED LOW PRICES

On Over 10,000 New Mac Products

LIFETIME MEMORY WARRANTY

PC100 32 MB ... 64 MB \$45 ... \$59  
PC100 128 MB ... 256 MB \$115 ... \$279  
SO-DIMMS 64 MB ... 128 MB \$65 ... \$119  
SO-DIMMS 128 Low ... 256 MB \$129 ... \$289  
72 PIN SIMMS 32MB ... 64MB \$49 ... \$89  
168 PIN DIMMS 32MB ... 64MB \$59 ... \$110  
3.3 VOLT DIMMS 32 ... 64 MB \$65 ... \$129  
COMPACT FLASH 16 ... 32 MB \$59 ... \$75  
COMPACT FLASH 64 ... 128 MB \$195 ... \$279  
SMART MEDIA 64 ... 128 MB \$195 ... \$279

Order Toll Free in the USA

1-800-600-2708

Ph: 818-904-1400 Fax 818-904-1410

197 on card or www.macworld.com/getinfo

### Software Specials QuarkXpress 4.5G49

Apple Mac OS 7.6/8/8.1/8.5/9 \$49/55/59/69/89  
Act V2.8/Acrobat V3/V4/Reader \$129/99/189/235  
AntiVirus/SAM V4/Apple Utilities CD \$49/29  
Bryce2/3D/4/3D Suites \$69/99/155/379  
Claris Emailer/DRAW/Calendar Maker \$69 ea.  
Claris Works V4/5/AppleWorks \$49/59/89  
Claris Impact/Organizer/2/HomePageV3 \$69 each  
Corel DRAW/9/WordPerfect V3.5 \$149/289/575  
Director V5/Studio6/Studio5 \$199/389/489/589  
DeBabelizer V3/ Dante Retrospect 4.1 \$159/99  
Extensis MaskPro2/PortFolio \$199/109  
Extensis PreFlight Pro/PhotoGraphics \$269/99  
Extensis PhotoTool3/OXTool4 \$129/129  
FileMaker Pro V2/4/1/Server3 \$49/99/159/589  
Final Cut Pro/FlightCheck/Up. \$949/\$355/85  
Flash 4/Freehand 8/DreamWeaver2 \$249 ea.  
Fontographer V4/Freehand V5 Studio \$199 ea  
FreeHand V8 COMP/Upgrade \$ 99  
FrameMaker V5/V5.5/FWB CD Tools \$389/489/399  
FWB Hard Disk Tool Kits PEV/3 \$39/89  
GoLive4/Infiniti-D V3/4/5 \$269/349/399/489  
Illustrator V5.5/6/7/8/Fireworks2 \$89/189/289/159  
Kai's PowerTool LE/V3/V5/V6 \$29/69/95/145  
Microsoft Office 4.2.1/97/Pro. \$200/\$149/199/389  
Microsoft Office 98/98/98/98 Full \$99/229/\$299  
MediaCleaner Pro/QuarkXpress 4.0.4 \$389/649  
Norton Utilities/Anti-Virus Bundle \$79 both  
Norton Utilities V3.5.4/NetObject V3 \$39/49/149  
Painter3/4/5/5.5/FrontPage98 \$69/99/149/229/99  
Pantone Color Drive/PageMill V3 \$85 each  
PageMaker V5/6.5/PhotoFlash \$189/289/69  
Persuasion V3/V4/PowerPoint98 \$99/189/189  
PhotoFrame Vol 1/2 \$89 ea. \$159 both  
Premiere LE V3/V4/PhotoDuxe \$289/189/289/25  
Poser V2/3/4/QuarkXpress 4.0.4 \$79/229/649  
Quick Book Pro V4/Quicken 7/Special \$179/35/39  
TrueDream 3D/Studio V5/5.5 \$89/189/289  
SuitCase3/Suffit/Delux5/Spring Clean 25 \$79/69  
SoundEdit16-DEC II/Swim/Suit CDS \$19/249/29  
StrataStudio Pro V2/V2.5 N-Shop \$489/635/49

### Apple G4 - \$1489

G3/350/400/450MHZ \$1089/1389/1789  
G4/350/400/450MHZ \$1489/1789/2389

### JAZ/ZIP, Hard Dr. & CDR

400MB/1GB/2GB/3GB \$69/119/149/169  
4GB/6GB/9GB/18GB \$195/259/299/459

### Manager Specials

\*UMAX Mirage D16L Color  
Scanner-12X17, Dual Lens  
w/Transparency \$1089

\*Kodak Digital Camera  
DC200+ 1152X864 \$285

### \*Epson 5000 Color Printer

- Color Proof \$2689

Epson 1520/PhotoEX (17X22) \$369/339

Jaz ext. Dr. 1GB/2GB \$199/\$339

Zip Dr. w/Cart. Int. / Ext. \$109/\$125

Ricoh 4X/4X20X w/Toast \$349

Yamaha CD-RW 8X/4X/24Xw/Toast \$399

Apple DVD-ROM Dr. w/MPEG Decoder \$399

### COMBO Drives:

9GB + CD-R Ext. SCSI \$699

18GB AV + JAZ + CD-R \$989

JAZ+ZIP \$289

### Tappe Ext. Drive

SDT2000/4000/5000 \$199/399/499

SDT7000/9000/10000 \$699/849/1089

DLT 30/40/60GB \$1189/1489/1989

USB Drive - 3GB/4GB/6GB \$99/149/199

### Super RAID - Quantum/Seagate

SCSI Case HH/FF \$29/49\*

\* 8GB/18GB RAID - \$ 489/ \$789

\* 36GB/72GB RAID - \$ 1389 / \$2589

### Iomega

1.0GB Jaz \$75\*

100MB Zip \$10\*

### SyQuest

44MB/88MB \$25/\$35

200/270MB \$49/59

EZ135/230 \$29/\$39

SyJet 1.5GB \$95

### M.O. Cart.

128/230MB \$8/12

640/650MB \$29/34

1GB Tahill \$89

1.2/1.3GB \$49/59

2.6/4.6GB \$149/189

### Close-Out

\*Targa 2000

Pro/RTX\$2689/4589

\*MAC 20" Color

Monitor \$389\*

\*64/128MB

### PC100 - \$139/239

\*SyQuest 270/200MB

Ext. Drive \$249/159

\*Fujitsu 230MB MO /

WANG DAT \$199 ea.

\*SONY 650MB/1.3GB

M.O. Dr. \$589/889

\*AUTOCAD 14 \$989

Canvas V5/V6 \$249/339

\*Conflict Catcher V3/4/6

\$39/\$97

\*M.S. WIN95/98/Project

98 \$69/99/289

\*M.S. Words V5/V6/98

\$89/189/269

\*WordPerfect3.5/Win

dows98 \$75/95

Local: (303) 571-1900  
Fax: (303) 571-5020  
Hours: M-F 8-6 Sat 10-5

## MediaGuide

Your #1 Macintosh Source!

### SHOP ONLINE!

Need a Mac?  
Need stuff for your Mac?  
We've got it.

NEW • USED • PARTS • RAM • PERIPHERALS & TONS MORE  
www.MediaGuide.com

Not online? No problem! Call (888) 466-2271

OEM CDs:	Brand New
MacOS 8.5.....\$49	Sony 24x
Norton Util 4.0...\$12	CD-ROM
ClarisWorks 5.....\$29	Int.....\$79
MacOS 8.1.....\$29	Ext.....\$109

HOT Bundle specials! (CPU plus 13/14 monitor, kb/m)  
Ilii 8/425...\$129 • Ilsi 9/230...\$119 • Ilvx 8/425...\$139  
Q650 16/425/CD...\$199 • Q630 20/250/CD...\$199  
6100 24/350/CD...\$299 • 7100 40/425/CD...\$399  
Many additional models available! Call for details!

Duo 280c 40/1gig/14.4...\$349

your complete used Mac resource

Mac of All Trades takes the fear out of buying and selling used equipment.



Refurbished and tested  
Mac-savvy advisors  
Best Prices  
800.304.4639  
Direct : 404.355.5144  
Cust. Service : 404.355.5668  
Fax : 404.355.5461  
500 Bishop Street, Suite E.3  
Atlanta, Georgia 30138  
macofalltrades.com

Fax: 310-782-5974

http://www.imagesolutions4u.com

E-Mail: Imagesol4U@AOL.com

385 Van Ness Ave. #110 • Torrance, CA 90501

800-352-3420

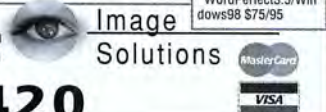



## MAC GLOBAL

SYSTEMS AND PERIPHERALS • SALES AND SERVICE

4750 ALMADEN EXPRESSWAY STE # M • SAN JOSE, CA 95118

PowerMacs	Powerbook
G3 233 DT \$1175	520 4/160 \$325
G3 266 DT \$1375	520c 12/240/19.2 \$450
6100 8/500 \$225	540 12/240 \$375
7200 8/500 \$325	540c 12/320/19.2 \$575
7500 16/500 Call	5300cs 8/500 \$575
8500 16/1G Call	1400cs 117/133/166 Call
9500 32/2G Call	3400c 180/200 \$1150/1050
	G3 233/250/266/300/333 Call
Memory	Batteries
4Mb. 72-pin \$8	New Apple 5300 NiMH \$39
8Mb. 72-pin \$15	
16Mb. 72-pin \$30	<b>Quadras/Performas</b>
32Mb. 72-pin \$60	630/605/650/800/840/950
Printers	6200 8/1G/CD \$299
Styl/Wrtr. II \$175	5200 8/500/CD \$499
Styl/Wrtr. 1200 \$155	6400/6500 Call
Laser 300 \$299	Monitors
Laser 320 \$449	13" RGB \$89
Laser 4/600 Call	14" Color \$149
Software	15" Appl. Mult. \$189
Mac OS 8.1 \$24.99	17" Appl. Mult. \$250
	20" Apple Mult. \$550

TOP DOLLAR Paid for Memory, Powerbooks, and CPUs

1-800-722-8864

PHONE: 408-265-6653

FAX: 408-265-6660

WWW.GLOBALDEALS.COM

178 on card or www.macworld.com/getinfo

**CHEAP MACS!**

## LIQUIDATION STATION

www.liquidationstation.com  
800-382-6246

227 on card or www.macworld.com/getinfo

think mac

## LIQUIDATION

dealer destroyer  
**BLOWOUT SALE**

for more information  
CALL US TODAY TOLL FREE  
**877-638-2822**

SCHOOL AND GOV'T PO'S ACCEPTED

ALL MAJOR CREDIT CARDS ACCEPTED

Where the price is right and the service is priceless!  
1035 Samsonite Blvd. Suite C • Murfreesboro, TN 37129  
PH: 615-904-1070 FAX: 615-890-1070

## WHY IS THE COMPETITION SHAKING?

**BECAUSE**

# 1-800-4-MEMORY

**IS HERE**

## WE CAN BEAT

ANY QUOTED PRICE ON ANY MEMORY FOR ANY COMPUTER (NOTEBOOK, DESKTOP, PRINTERS) ANYWHERE . . . PERIOD!

- LIFETIME WARRANTY
- FREE TECH SUPPORT
- NO CREDIT CARD SURCHARGE
- MOST ORDERS SHIPPED SAME DAY

**CALL AROUND THEN CALL US**

CHECK OUR WEB SITE FOR SPECIALS  
**WWW.18004MEMORY.COM**

# MEMORY

Weekly Web Deals Check It Out!

ABSOLUTELY, POSITIVELY,  
**THE BEST PRICES!**

Plus, Lifetime Warranty on all RAM!

G4/YOSEMITE - PC 100	233/266/333 iMAC™ RAM	G3 SDRAM - In Stock!!
32 mb \$ 49	32 mb \$ 41	32 mb \$ 48
64 mb 74	64 mb 76	64 mb 74
128 mb 145	128 mb 149	128 mb 145
256 mb G3/G4 339/365	256 mb 339	256 mb 332
PowerBook® G3 (98-99)	168 Pin DIMMs	SIMMs 72 & 30 pin
32 mb \$ 41	16 mb \$ 24	4 mb 30 pin \$ 7
64 mb 76	32 mb 56	16 mb 30 pin 19
128 mb 149	64 mb 101	16/32 mb 72 pin 25/55
256 mb 339	128 mb 169	64 mb 72 pin 6100/Sampler 83

\*\*\* At Press time the Memory market was extremely volatile. Please call for the most up-to-date prices.

CACHE • VRAM • PRINTER, DIGITAL CAMERA & PC-CLONE MEMORY AVAILABLE

Special Web Site Pricing available only at [www.macsolutions.com](http://www.macsolutions.com)

MacSolutions, Inc. Fax: (310) 966-4433  
11933 Wilshire Blvd, West Los Angeles, CA 90025  
University & School P.O.'s Welcome.

All prices are subject to change. Merchandise subject to prior sale. Please call for up-to-the-minute info and availability. Not responsible for typographic errors. Limited to stock on hand. Ad Code #114

Plus, Great Deals on Hard Drives, Software and more...

Seagate 4.5gb MedSCSI \$179	Norton Utilities 4.0 35
IBM 9.1gb UltraStar SCSI 289	Microsoft Office 4.2.1 CD only \$ 75
Fujitsu 4.3gb IDE 95	Mac®OS 9 79
Qntm 17.3gb IDE 170	Mac®OS 8.1 CD only 25
Zip 100 10 Pak 89	Mac®OS 8.6 Update w/free 8.5 CD

**WE BUY, SELL & TRADE MACS!**  
CALL 800-80-WE-BUY

Super Deals on Pre-Owned Macs!

9600/200	32/4gb/12x	\$ 1,400
6400/200	16/2.4gb/8x	450
7500/100	8/500/CD	395
7200/120	16/1gb/4x	385
7200/75	16/1gb/4x	325
7100/66	8/230/2x	225
6100/60	8/230	175
Centris 610/20	8/80	70
PwrBook 1400cs/133	16/750/CD	885
PwrBook 1400cs/117	12/750/Floppy	700
PwrBook 5300cs/100	8/500	550



Secure Online Ordering or call 800-873-3RAM  
**www.macsolutions.com**

**WE BUY USED MACS!**



## MEMORY SPECIALISTS

- Printers
- Monitors
- Supplies
- Scanners
- Media
- Hard Drives
- Modems
- Software
- Accessories
- Cables/Adapters
- Mice/Input Devices
- Keyboards
- Network Products
- Hubs/NICS

**Serving Mac User's Since 1991.**  
**We sell only NEW, Grade A Full MFG Spec Ram**

**Low Prices & Personalized Service**



**Tahoe Peripherals**  
5301 Longley Lane, Suite A-2,  
Reno, NV 89511 • Fax 775-823-2200  
[www.tahooperipherals.com](http://www.tahooperipherals.com)

800-307-3434

212 on card or www.macworld.com/getinfo

## You're the Winner!

In your hands is the only April issue of MacWorld magazine with this ad. Really, we wouldn't kid you about this. Honest!

OK, so we're lying.  
The truth is everyone sees this ad, and everyone checks out our web site for the best selection of upgrades for the Mac. Everyone. So what are you waiting for?



**Helping Older Macs Kick Butt.**

205 on card or www.macworld.com/getinfo

Got Memory?

209 on card or www.macworld.com/getinfo

# MEMORY

The Best Memory Prices & Guarantee

800-662-7466

Secure online ordering: [www.datamem.com](http://www.datamem.com)

Lifetime Memory Replacement Guarantee

DMS will meet or beat anyone's price!

SONNEX  
SIMPLY FAST

POWERLOGIX

EPSON

UMAX

USB

i  
omega

LACIE

16-bit Color Card with Ethernet for PowerBook 5300 Series  
**\$29.00!**

Pentium® Computer System Specials

USB Scanners/Printers & Accessories

DMS

DATA MEMORY SYSTEMS

DMS ACCEPTS GOVERNMENT, EDUCATIONAL & CORPORATE P.O.s WITH PRIOR APPROVAL  
FAX P.O.s 24 HOURS TO DMS @ 603.898.6585  
Open M-F 9a.m. 'til 9p.m.

213 on card or www.macworld.com/getinfo

# MEMORY MADNESS

The LLB Company, Inc.

1-800-848-8967

www.llb.com International: 425.881.1880 Fax: 425.881.1930

### DIMMs

\$169<sup>128MB</sup>

BEIGE G3- PC 66

16MB 4x64.....\$58

32MB 8x64.....\$80

128MB 16x64.....\$169

256MB 32x64.....\$340

\$129<sup>64MB</sup>

168 PIN EDO 3.3VOLT

16MB 2x64.....\$42

32MB 4x64.....\$69

64MB 8x64.....\$129

\$122<sup>64MB</sup>

168 PIN EDO 5 VOLT

16MB 2x64x.....\$40

32MB 4x64.....\$61

64MB 8x64.....\$122

### DIMMs

\$82<sup>64MB</sup>

G4/BLUE/WHITE G3- PC100

64MB 8x64.....\$82

128MB 16x64.....\$171

256MB 32x64.....\$375

\$60<sup>32MB</sup>

168 PIN FAST PAGE DIMMS

32MB 4x64.....\$60

64MB 8x64.....\$120

128MB 16x64.....\$350

### SIMMs

\$58<sup>32MB</sup>

72 PIN FAST PAGE SIMMS

8MB 2x32.....\$21

16MB 4x32.....\$32

32MB 8x32.....\$58

### FROM THE LLB COMPANY

#### IOMEGA

Zip Drive \$119

Zip Drive USB \$151

ZIP 100 disk \$10

ZIP 100 disks -3-pk \$28

ZIP 100 disks -10-pk \$89

Jaz 1GB disk \$89

Jaz 1GB disks - 5-pk \$405

Jaz 1GB disks - 20-pk \$1524

#### NEWER TECHNOLOGY

For the PowerMac 6100 Series

Maxpowr G3 210MHz/512K Cache \$442

Maxpowr G3 240MHz/1MB Cache \$540

NEW For the PowerMac 7500/8500/ Etc.

Maxpowr G3 333MHz/1MB Cache \$989

Maxpowr G3 400MHz/1MB Cache \$1581

NEW For the PowerMac G3 Series

Maxpowr G3 333MHz/1MB Cache \$889

Maxpowr G3 366MHz/1MB Cache \$1285

Maxpowr G3 400MHz/1MB Cache \$1581

#### Powerbook

WALL ST./ iMAC		iBOOK		PB 500 SERIES		PB3400 G3	
128MB	\$170	256MB	\$360	32MB	\$111	128MB	\$208
64MB	\$80	128MB	\$170	16MB	\$62	64MB	\$125
32MB	\$55	64MB	\$80	8MB	\$45	32MB	\$75
16MB	\$42	32MB	\$55	4MB	\$40	16MB	\$60
PB 3400 SERIES		PB 5300 SERIES		PB1400 SERIES		PB 2400 SERIES	
128MB	\$208	48MB	\$150	48MB Kit	\$180	64MB	\$135
96MB	\$170	32MB	\$120	24MB	\$90	32MB	\$95
64MB	\$120	16MB	\$60	16MB	\$59	24MB	\$80
32MB	\$68	8MB	\$55	8MB	\$52	16MB	\$75

#### COMPARE OUR LOW SHIPPING RATES

E-Mail: [sales@llb.com](mailto:sales@llb.com) • PO's accepted upon approval  
No surcharge on credit cards  
• Returns subject to restocking fee  
• Prices subject to change, not responsible for errors • International orders welcome  
Mail PO's to:  
2791 152nd Avenue N.E.  
Redmond, WA 98052

209 on card or www.macworld.com/getinfo

168 April 2000 MACWORLD



Open Monday-Friday: 9am-8pm & Saturday: 10am-5pm CST E-Mail Us at: [owc@macsales.com](mailto:owc@macsales.com)

# Other World Computing

Serving the Mac Universe Since 1988



[www.macsales.com](http://www.macsales.com)



**800-275-4576**



**FAST!  
EASY!  
SECURE!**

Quality Products at Competitive Prices from a Friendly and Mac Knowledgeable Company!

## OWC has the G3 and NEW G4 Upgrades Your System Deserves!



### SONNET Crescendo Nubus Series from \$239

Upgrades For PowerMac 6100/7100/8100/8150/9150/ Radius; Performa 611X Series  
 G3/240-266mhz 512k - \$239  
 G3/240-266mhz 1mb - \$295  
 G3/300mhz 1mb - \$339  
 G3/400mhz 1024k - \$485  
**New G4 Upgrades Now Available!**



### SONNET Crescendo PCI Series from \$198

Upgrades for PowerMac7300/7500/7600/8500/8600/9500/9600s;  
 WGS 7350/8550/8650/9650; PowerCenter/Wave/Tower; UMtax SP001/700  
 G3/266mhz 512k - \$198  
 G3/300mhz 1024k - \$295  
 G3/300mhz 512k - \$239  
 G3/400mhz 1024k - \$389  
 G3/500mhz 1024k - \$675  
**NEW! \$549**  
**NEW! \$729**



### SONNET Banker G3 Series from \$198

G3 Upgrades for PowerMac 4400/5500/ 6360/6400/6500/ 20th Anniversary Mac  
 PowerBase; UMtax C500/600 StarMax 3000/ 4000/5000 Series; Most Motorola Clones  
 G3/250mhz 512k - \$198  
 G3/300mhz 1024k - \$295  
 G3/300mhz 512k - \$239  
 G3/400mhz 1024k - \$475  
 G3/500mhz 1024k - \$675

**DaughterCard Gives Your PCI Mac ZIF G3/G4 Upgradeability!**

### Interex XLR8 ZIF Carrier PCI Daughter Cards

XLR8 ZIF Carrier w/o Processor \$149  
 ZIF Carrier w/OWC Mercury G3 333mhz 1mb \$295  
 ZIF Carrier w/OWC Mercury G3 350mhz 1mb \$345  
 ZIF Carrier w/OWC Mercury G3 400mhz 1mb \$399  
 ZIF Carrier w/OWC Mercury G3 500mhz 1mb \$749  
 ZIF Carrier w/G4 Processor **\$CALL**

**Z.I.F.**

**Call for G3 and G4 ZIF Upgrades for all G3 Beige and G3 Blue/White PowerMacs! 500mhz currently in stock and available! 400mhz Only \$265!**

Call or Visit [www.fastermacs.com](http://www.fastermacs.com) for our complete line of G3 and G4 Processors!

### IBM 9.1gb

7200rpm 7.5ms 5yr Warranty

**\$249** int. **\$299** ext.

FWB 3.0 Hard Drive ToolKit included with drive for \$10 additional.

### SCSI Hard Drives

Quantum	int.	ext.
4.5gb Viking II 7200rpm 512k 7.5ms 5yr.	\$195	\$249
9.1gb Atlas III 7200rpm 512k 7.5ms 5yr.	\$229	\$265
18.2gb Atlas III 7200rpm 1024k 7.8ms 5yr.	\$339	\$399

Seagate	int.	ext.
2.1gb Barracuda 7200rpm 8ms 1yr.	\$89	\$139
9.1gb Ultra2 Barracuda 18LP 7.1ms 5yr.	\$299	\$395
18.2gb Ultra2 Barracuda 18LP 7.1ms 5yr.	\$459	\$555

IBM	int.	ext.
18.2gb UltraStar 18ES 7200rpm 7.5ms 2048k 5yr.	\$435	\$499

Visit [www.macsales.com](http://www.macsales.com) for a full selection of UltraWide and Ultra2 drives up to 50gb in a single device!

### IDE Hard Drives Seagate

**SAVE BIG! 6.4gb Western Digital Only: \$99**

IBM	Seagate	Quantum
15.2 - \$149	6.4gb - \$109	6.4gb - \$109
25.2 - \$225	13.0gb - \$139	13.0gb - \$129
37.5 - \$335	28.0gb - \$299	20.5gb - \$209

Call or visit [www.macsales.com](http://www.macsales.com) for our full line!

### IDE PowerBook Drives

for PowerBook150, 1901, 4000, 5300, 3400.  
 G3 PowerBooks Duo 2300 and 2400 Series.  
 4200rpm w/ 3 yr. warranty.

6.4gb IBM TravelStor SuperSlim	\$255
10.1gb Toshiba SuperSlim	\$299
10.1gb IBM TravelStor Slim	\$349
12.0gb Toshiba SuperSlim	\$329
15.0gb IBM TravelStor Slim	\$549
25.0gb IBM TravelStor non-Slim	\$645

### VIDEO CARD SPECIALS

**ixMicro Ultimate Rez 128 PCI \$75**

**ixMicro 1x3D MacRocket 4mb PCI Video \$59**

With 8mb of VRam  
 NEW WITH 3 YEAR WARRANTY

With TV Out!

### GAMING/ENTERTAINMENT SPECIALS

**iMac\* Voodoo II GameWizard 8mb \$169**  
 \*Rev A/B iMac Only

**3dFx Voodoo III PCI 3D Accelerator w/16mbs. \$129**

**Cyborg 3D USB Joystick \$65**

**Interex XLR8 InterView USB Video Capture Device \$99**

**Bungie Marathon Action Pack \$45**

**Descent III \$45**

**Carnageddon \$24**

**MacSoft Unreal Tournament \$39**

### www.fastermacs.com

- More Stuff to Make your Mac a FasterMac!
- Upgrades for Older Macs too!

### www.macsales.com

- More Mac products and information
  - Free Ground Delivery and
  - \$5 FedEx Delivery when you place your order online!
- Visit us for USB, Monitors, Printers, USED Deals & More....

### Mac Memory

**G3/G4/iMac 350 & 400mhz SDRAMs**

Apple Spec PC100 Memory for ALL Beige G3 Desktops, Minitowers, All-In Ones, & New B&W G3 and G4 Computers (work with PC's too)

32mb - \$59	64mb - \$85	128mb - \$169
256mb (66mhz for Beige) \$339		
256mb (100mhz for G3BV & G4) \$399		

### iBook/PowerBook Wallstreet & Lombard/iMac 233, 266, 333mhz

32mb - \$59	5V	5V Edo
64mb - \$89	\$65	\$79
128mb - \$169	\$139	\$149
256mb - \$349	\$199	\$185

### 72 Pin Simms

16mb - \$25	32mb - \$69	64mb* - \$99
-------------	-------------	--------------

\*for 6171/8100 and compatibles only.  
 Call or visit [www.macsales.com](http://www.macsales.com) for other memory & videovram upgrades.

OWC is a Techworks Authorized Reseller. Call or Visit our website at [www.macsales.com](http://www.macsales.com) for the best prices on Techworks Brand Memory. Prices, Specifications, and Availability subject to change without notice. Items returned complete in original returned within 30 days may be subject to up to a 15% restocking fee. No return will be accepted without Return Merchandise Authorization Number.  
 \* See [www.macsales.com](http://www.macsales.com) for Free Delivery details

Other World Computing

224 West Judd St., Woodstock, IL 60098 Int: (815) 338-8685 Fax: (815) 338-4332



## WHOLESALE WATERLESS COLOR PRINTING FROM YOUR COMPUTER FILES

**1000 FULL COLOR BUSINESS CARDS FOR \$100** Sug. retail price \$179  
**1000 FULL COLOR POSTCARDS FOR \$149** Sug. retail price \$249

Printed waterless at 300 line screen from your computer files on Super Premium 10pt. Kromekote with our FREE scratch-resistant aqueous coating.

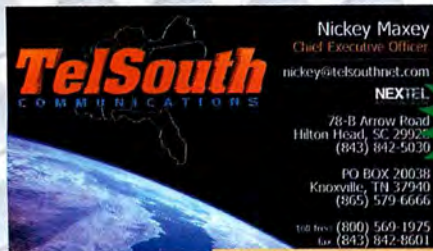

**TelSouth**  
COMMUNICATIONS

Nickey Maxey  
Chief Executive Officer  
nickey@telsouthnet.com  
NEXTEL

78-B Arrow Road  
Hilton Head, SC 29928  
(843) 842-5030

PO BOX 20038  
Knoxville, TN 37940  
(865) 579-6666

Toll Free: (800) 569-1925  
Fax: (843) 842-8601

Try Our  
Fast 4/C Print Quotes!  
**NEW! 100 us at  
22013993**

- BUSINESS CARDS
- POSTCARDS
- CD INSERTS
- CD TRAY LINERS
- BROCHURES
- BOOKLETS
- NEWSLETTERS
- POSTERS & MORE



## FEATURING 300 LINE SCREEN WATERLESS OFFSET PRINTING

Rates for Brochures, Booklets and Flat Sheets are also available.

**4-COLOR WATERLESS SPECIAL**

**1,000 18" x 24" POSTERS**

18" x 24" posters printed 4/0 from your computer files on 100# gloss text.  
Price includes full bleed and FREE aqueous coating  
Get 5,000 18" x 24" Posters for only \$2,599.

**\$1299**  
SUGGESTED RETAIL \$2,069



GRAPHIC ARTS  
AVAILABLE



**copy craft**  
PRINTERS, INC.

4413 82nd Street • Lubbock, TX 79424 • FAX: 806.798.8190

QUARK  
Authorized  
Service Bureau

Factory Authorized  
COREL  
Service Bureau

Se Habla  
Español

Email your requests for printing quotes to [request@copycraft.com](mailto:request@copycraft.com)

**1.800.794.5594**

CALL TODAY FOR A FREE COPY OF OUR NEW 32-PAGE FULL COLOR CATALOG

Visit [www.copycraft.com](http://www.copycraft.com) for more Specials...in English or Spanish!

223 on card or [www.macworld.com/getinfo](http://www.macworld.com/getinfo)

# data

When you absolutely,  
positively have to  
get your data  
back...

Be assured  
MicroCom will  
guide you through  
the recovery  
process...  
Diagnostic reports  
back to you  
within hours, with  
step-by-step  
updates on every  
recovery situation.  
Call now for an  
immediate consultation.



[www.data-master.com](http://www.data-master.com)

**MICROCOM**  
20802 Plummer St. Chatsworth, CA 91311 • 818 718-1200  
**800 469-2549**

Get a

**Free  
Gift!**

Be one of the first

**5**

readers with  
proof of purchase  
from a Macworld  
Shopper  
advertiser from  
this year &

**get a cool gift!**

Fax receipt &  
contact info to  
**415•243•3592**

Look  
here for  
all your  
Macintosh  
service  
needs!

**Macworld**  
SHOPPER



### DELUXE COLOR PRINTING!

Our ultra thick, deluxe high gloss cards stand out from the rest!

**FREE SAMPLES Call Now!**



**1000 POSTCARDS \$145**

**1000 BIZCARDS \$60!**



- Super thick card • Ready in 5-7 days!
- Glossy UV coating • NO Film Charge!

**1-800-957-5787**

www.postcardpress.com

Preferred by over 5,000 professionals!

## BIG POSTERS & HUGE DISCOUNTS

FROM YOUR COMPUTER FILES

BESTEST QUALITY PRINTS AT THE BEST VALUE AROUND • STATE OF THE ART EQUIPMENT • UP TO 800 DPI

<b>24" x 36"</b> Full color print on 7 mil high or low gloss paper	<b>36" x 48"</b> Full color print on 7 mil high or low gloss paper	<b>48" x 72"</b> Full color print on 7 mil high or low gloss paper
<b>\$25</b>	<b>\$50</b>	<b>\$125</b>
<small>NO MINIMUMS VOLUME DISCOUNTS</small>	<small>NO MINIMUMS VOLUME DISCOUNTS</small>	<small>NO MINIMUMS VOLUME DISCOUNTS</small>

FOR MORE INFO & PRICING VISIT OUR WEBSITE  
**www.BIGPOSTERS.com**  
 CREATIVE JUICES PRINTING & GRAPHICS INC.  
(In New York) Tel: 516-520-8333 Fax: 516-520-8384 48 Westwood Pl., Levittown, NY 11756  
**1-888-880-HUGE**

220 on card or www.macworld.com/getinfo

### Implosion Publishing

1000	4x6	Full-color Postcards	\$125
1000	8.5x11 4/0	100# Gloss Text	\$275
1000	11x17	4 page Brochures 4/4	\$795
1000	18x24	Posters 4/0	\$795

All prices include film.  
Call for more specials!

1921 East Colonial Drive • Orlando, Florida 32803  
 407.898.5573 • fax: 407.898.7665  
 toll free: 888-323-5431

216 on card or www.macworld.com/getinfo

### DATA RECOVERY: 800-440-1904

7 good reasons to choose DriveSavers:



"We Can Save It!"

1. DriveSavers is the Authorized to pre-form Data Recovery Service on all Apple computers and hard drives.
2. Recommended and certified by all drive companies to open the drive and still maintain the warranty.
3. Retrieve recovered data instantly with DATAEXPRESS™ over secured Internet lines.
4. 24-hour, onsite, and weekend service available.
5. Advanced, proprietary recovery techniques.
6. Featured on CNN, BBC, Discovery Channel. Also in Forbes, MacWorld, Mac Addict, Popular Mechanics, and many others.
7. Federal and State Contracts (GSA, CMAS.)



Since 1985  
INTL: 415-382-2000

**www.drivesavers.com**

211 on card or www.macworld.com/getinfo

## SO YOUR HARD DRIVE SPLIT AND TOOK ALL THE DATA WITH IT? PROFESSIONAL DATA RECOVERY SERVICES.

HARD DRIVES, FLOPPY DRIVES, SYQUEST IOMEGA, ORB AND OPTICAL. SAME-DAY SERVICE AVAILABLE. REASONABLE RATES. VIRTUALLY ALL OPERATING SYSTEMS. GUARANTEED RESULTS!



**800-743-0594**

online quotes <http://www.totalrecall.com>

2462 WAYNOKA ROAD COLO SPRINGS, CO 80915 • 719-380-1616 • FAX 719-380-7022

218 on card or www.macworld.com/getinfo

© 1999 TOTAL RECALL, INC. CALL FOR DETAILS



## DATA RECOVERY

ALSO IN CALIFORNIA For MAC - (Hard Drives, Opticals, Removables)

By Nick Majors' DATA RECOVERY LABS  
 "The Best Data Recovery Service available - Anywhere - at any Price!"

Dedicated in-house MAC specialists are available to work on your emergency data recovery. Complete facility with clean rooms and full MAC capabilities.

Free evaluations. All recoveries are 100% satisfaction guaranteed. Complicated / top priority projects are our specialty.

USA • Canada • Japan **1-800-563-1167**  
[www.datarec.com](http://www.datarec.com)

## the compression factory™

Professional QuickTime Streaming Services

We offer 24/7 encoding and hosting for QuickTime 4 streaming media for video-on-demand & live events. Our state of the art automated compression facility provides clients such as Apple Computer, HBO, Fox Sports, Warner Bros., VH1, and Reprise Records with the highest possible quality RTSP and HTTP video & audio. Visit our QuickTime microsite for more info and online streaming samples:

<http://www.compressionfactory.com>

The Compression Factory is a trademark of 21st Century Media™ LLC

- ▶ 24/7 QuickTime digitizing & encoding
- ▶ Beta SP, DV & other sources accepted
- ▶ Same-day service available via FTP
- ▶ MacDSX QuickTime Streaming Server hosting
- ▶ Encoding, hosting and systems consultancy
- ▶ DVD-R, DVD-ROM, DVD-Video production

Call **415 884 2155** today  
 Discover the future of broadband communication

225 on card or www.macworld.com/getinfo



**G3/iMac Parts In Stock!** **800-WE-FIX-MACS**  
Free Diagnostics • Best Prices • Best Warranties • Huge Inventory

<b>Logic Boards:</b>	<b>G3/450 All-In-One</b>	<b>G3 450MHz</b>
6400, 6500, 7500, 8500, 8600, 9500, 9600	32/4GB/24xCD/Zip <b>\$1299</b>	ZIF CPU <b>\$249</b>
From <b>\$259</b>	6100 8/0 <b>\$99</b>	w/XLR8 ZIF Carrier <b>\$399</b>
<b>iMac/G3 Logic Board</b>	<b>PowerComputing Specialists</b>	<b>Apple 24x CD \$89</b>
From <b>\$299</b>		

2202 N. First Street San Jose, CA 95131 • **800 933-4962** • [www.allmac.com](http://www.allmac.com)  
Repair • Upgrade • Buy • Sell • Trade New • Used • Refurbished

**MAC REPAIR & UPGRADE**  
24 HOUR SERVICE TURNAROUND • LONGER WARRANTY  
FREE DIAGNOSTIC • COMPETITIVE PRICE



**DT & T  
MACINTOSH  
SERVICES, INC.**

\* Specialize in component repairs:  
• Power Mac • Power Book • Logic boards  
\* Advance Exchanges

**800-622-7977**

3095 Osgood Court, Fremont, CA 94539 • Tel: 510-661-0999 • Fax: 510-661-6788  
<http://www.dttservice.com>

215 on card or [www.macworld.com/getinfo](http://www.macworld.com/getinfo)

**CD-ROM PRODUCTION**

1000 Retail-Ready Stamped CDs  
Includes two color discs, four color glossy insert & tray cards, jewel case, and poly wrap. Complete turnkey — just send a CD-R and art files! Call for details.



Business Card CDs!  
New! 18Mb of data or audio on a business card shaped disc. It really plays! See our web site for details.

We Also Offer:

- CD-R silk-screening service
- Short run CD-R duplication
- Standalone CD-R dupers

Call today: (800) 255-4020



**CATALOGIC**  
Your CD-ROM Production Source™  
<http://www.catalogic.com>

990 Richard Ave Ste 103 • Santa Clara, CA 95050  
Telephone: 408-486-0800 Fax: 408-486-0809



**Data Recovery in hours.**

- Over 10 years of experience with clients worldwide including Apple, NASA, HP, and FedEx.
- We've recovered more than half-a-million megabytes of Mac Data alone.
- You only pay when there's a recovery.
- Express One-Day Service is available.
- Call 24 hours a day.



**LAZARUS**  
DATA RECOVERY  
Working at the speed of business.

415-495-5556 • FAX 415-495-5553 • RESTRICTIONS MAY APPLY  
381 Clementina Street • San Francisco, California 94103

**800-341-DATA**

217 on card or [www.macworld.com/getinfo](http://www.macworld.com/getinfo)

**Digital Imaging**

Slides & Negatives \$3.75  
4x5 Transparencies/Negs \$30  
Large Posters & Displays \$45  
Scanning: Hi & Lo Res  
Kodak Photo-CD Scans  
Short Run Color Printing  
Show & Tell 39 W 38th St., NY, NY 10018  
[www.show-tell.net](http://www.show-tell.net)  
212 840-2912 212-840-7953 (fax)  
showtel@ibm.net • shotel@aol.com

219 on card or [www.macworld.com/getinfo](http://www.macworld.com/getinfo)

"THANKS TO THE  
**MACWORLD SHOPPER**  
SECTION OUR COMPANY  
HAS GROWN OVER 400%  
IN THE FEW SHORT  
MONTHS WE'VE  
ADVERTISED. AS A  
RESELLER OF HIGH-END  
QUALITY ERGONOMIC  
CHAIRS, I DEPEND ON  
**MACWORLD** TO HELP PUT  
ME IN TOUCH WITH EVERY-  
ONE FROM BANKERS TO  
MUSICIANS."

**Jim McGraw**  
Owner

[www.sittingmachine.com](http://www.sittingmachine.com)

**Macworld** **Get**  
**Info**

[www.macworld.com/getinfo](http://www.macworld.com/getinfo)

**Colorprints.com**

Virtual home of the  
**39¢**  
digital color print

visit our website at [www.colorprints.com](http://www.colorprints.com)  
for the lowest prices on

digital color prints  
color copies  
digital B&W  
wide format  
color posters

colorprints.com is your online copy center

**call toll free**  
**1.877.386.9111**

222 on card or [www.macworld.com/getinfo](http://www.macworld.com/getinfo)



## CLASSIFIEDS

**Macintosh Web Hosting!** Manage your site just like an iDisk!  
Plans start @ \$100/year w/ 50MB of space. [www.macserve.net](http://www.macserve.net)

**POWERBOOK GUY** - the premier source for quality PowerBooks,  
parts and accessories! [www.powerbookguy.com](http://www.powerbookguy.com) +1(510) 533 5500

Find out what **Steve Jobs** is up to! News, jobs, free support, pro-  
mos, discounts + 1.2 million Mac solutions. [www.macdirectory.com](http://www.macdirectory.com)

**Find Insanely Great Mac Jobs!** Post your resume at  
[MacTalent.com](http://MacTalent.com). Employers, search for free, post jobs for free!

**TERMINAL EMULATION** - Wyse 50/60/370, Viewpoint, VT100  
Carnation Software +1(425) 333 4288 [www.carnation-software.com](http://www.carnation-software.com)

[www.greendragon.com](http://www.greendragon.com) - Great games for MacOS™. Look what  
the sun did to our brains! Toll free +1(888) 624 0200

**Electronic Art for Design Professionals**-Download free samples:  
[www.ultimatesymbol.com](http://www.ultimatesymbol.com) 44-pg catalog call: +1(800) 611 4761

**MacTimeClock** - put your time clock on your Mac. Track  
employees, job cost and Payroll Interface. [www.systemsoptima.com](http://www.systemsoptima.com)

**WWW.JRTVIRGINIA.COM**  
Where America Shops For Furniture!

**SONY® 200/300 CD CHANGER CONTROL** - Turn your Mac into  
your own personal jukebox. [www.titletrack.com](http://www.titletrack.com)

**MacOnCall** - Sell your old Mac, Buy a new Mac, Upgrade your  
RAM And other SEXY stuff. [www.maconcall.com](http://www.maconcall.com)

**MACBOOKSHOP** - The Web's only all Mac bookstore, most books  
20% off. Weekly giveaways and reviews. [www.macbookshop.com](http://www.macbookshop.com)

**MURL.com** - Free internet service offering email, bookmarks, files,  
calendar, etc. - Anytime, Anywhere, Any computer. [www.murl.com](http://www.murl.com)

**MacTreasures** - Macintosh software not found on retail shelves.  
URL: [www.mactreasures.com](http://www.mactreasures.com) +1(408) 227 1645.

**ONLINE BIBLE - CHURCH SOFTWARE - Y2K, OS9 OK**  
**BY THE BOOK** [www.bythebook.com](http://www.bythebook.com) +1(800) 554 9116

[www.macbatteries.com](http://www.macbatteries.com) - PRAM (Clock) Batteries for Desktop  
Macs. 4.5 volt alkaline \$9.50 & 3.6 volt lithium \$4.50. 888-808-7726

**PowerBookCentral.com** - Shop here first. Prices, deals, news,  
classifieds, buyer's guide, more. [www.powerbookcentral.com](http://www.powerbookcentral.com)

**DIGITAL CAMERAS & ACCESSORIES** from Agfa, Epson, Fuji,  
Kodak, Nikon & Olympus. Very reasonable prices, best-in-class  
customer service. [www.epc-online.com](http://www.epc-online.com) +1(800) 310 8505.

**Protect Your iMac: Computer Skins** - custom-fit designer covers.  
All "flavors" only \$19.99 at [www.computerskins.com](http://www.computerskins.com).

**Maccentral.com** - Your #1 Mac news source updated hourly!

### completely ARE YOU COMPUTER LITERATE?

#### DO YOU KNOW HOW TO PROTECT YOUR COMPUTER FROM:

- Accidental Damage
- Fire
- Other
- Theft
- Vandallism
- Natural Disasters
- Power Surges
- Flood

**SAFWARE, THE INSURANCE AGENCY, INC.**, offers a comprehensive  
insurance plan to protect your valuable computer equipment. Our products  
cover your hardware, media and purchased software.

Pays for the cost of repair or replacement. No deduction for  
depreciation. 30-day trial period. Act now!

For cost and other details of coverage,  
including limitations and exclusions: **Call 1-800-800-1492**

Safeware®

The Insurance Agency, Inc.

Safeware, The Insurance Agency, Inc.  
P.O. Box 28296, Columbus, OH 43226-0296 (614) 781-1492 • Toll-free: 1-800-800-1492  
[www.safeware.com](http://www.safeware.com) • E-Mail: [safeware@safeware.com](mailto:safeware@safeware.com)

UT9294A-0100  
ahr

190 on card or [www.macworld.com/getinfo](http://www.macworld.com/getinfo)

### Great Advertising Opportunity!

## Advertise your Web Hosting service in Macworld

**1/3 of Macworld readers are  
employed in Internet/Web  
development fields.  
These readers are involved in  
choosing Web Hosting  
services for their companies.  
Don't miss this  
untapped market!**

## Place an ad in our classified section

Reach over 1 MILLION readers\* by  
advertising in the most widely-circulated  
Macintosh magazine in the market! To  
advertise please contact Alissa Mach at  
800-597-1594 extension 3, 415-243-3628, or  
email her at [alissa\\_mach@macworld.com](mailto:alissa_mach@macworld.com).

\*Source: Intelliquist CIMS v6.0



# THE #1 MACINTOSH RESOURCE

Get super savings on a subscription, plus a FREE CD-ROM.



Incisive Product Reviews  
Lab-based Performance Tests  
Tips, Tricks & Tutorials  
Technical Solutions  
Coverage of Emerging Technology  
And much more!

Macworld is the best way to stay on top of today's fast-changing Macintosh technology. And here's your chance to save big on a subscription, plus get the exclusive Macworld Clip Art CD-ROM containing an extensive collection of images, digital stock photos, and more — FREE with your paid order.

To get it all, go to  
<http://subscribe.macworld.com>



continued from page 176

### The Economist

February 23, 1995: "Apple could hang on for years, gamely trying to slow the decline, but few expect it to make such a mistake. Instead it seems to have two options. The first is to break itself up, selling the hardware side. The second is to sell the company outright."

*The Economist* forgot the third option—recovering, just like any normal company in any normal slump.

### The Financial Times

July 11, 1997: "Apple no longer plays a leading role in the \$200 billion personal computer industry. 'The idea that they're going to go back to the past to hit a big home run . . . is delusional,' says Dave Winer, a software developer."

Let me see here. Just how many computer companies are rushing to make their computers look like Apple's? Dell, eOne, IBM, Gateway—that sure smells like a "leading role" to me. As for hitting a home run, unless *I'm* the delusional one, every model released since Steve Jobs returned has been a smash-hit best-seller.

### Gaston Bastiaens, Former Apple VP

January 11, 1996: "Within the next two months, Sony will acquire Apple. At its current stock price (low 30s), it is a steal. Sony will be the white knight who will step into the picture."

A white knight? Why not? The notion of Sony buying Apple is definitely a fairy tale.

### BusinessWeek

October 16, 1995: "Having underforecast demand, the company has a \$1 billion-plus order backlog. . . . The only alternative: to merge with a company with the marketing and financial clout to help Apple survive the switch to a software-based company. The most likely candidate, many think, is IBM Corp."

What happened—did Sony back out?

### The Good Guys

While I'm ordering the plaques for the Tech Journalism Hall of Shame, I hasten to mention that a few people made better stabs at predicting the future. In the thick of Apple's hard times, for example, Prince Walid of Saudi Arabia bought 5 percent of Apple, telling the *New York Times* that the

company "is selling \$8 billion worth of goods even in the midst of the confusion. This is a heck of a company."

Analyst Pieter Hartsook also stuck his neck out, telling the *Financial Times* that "the risk of Apple going out of business and leaving no one to support its products is almost zero." And the former occupant of this very *Macworld* page, Steven Levy, wrote in *Newsweek* in 1996 that "Apple is far from a lost cause. Surely something can be done with a company that rakes in \$11 billion a year."

The most surprisingly clearheaded analysis of all, though, came from none other than Bill Gates in 1996. He said that Apple wasn't doomed, Apple just needed to "pick its markets and renew the innovation in the Macintosh."

And that, of course, is exactly how Steve Jobs saved Apple. He focused on specific markets, renewed innovation—and ignored the media. **m**

DAVID POGUE ([www.davidpogue.com](http://www.davidpogue.com)) is the author of *Mac OS 9: the Missing Manual* (Pogue Press/O'Reilly, 2000). Research assistance was provided by Asim Choudhri, Jay Datema, William Fraunfelder, Stephanie Lane, and Rebecca Luxford.

# THE #1 MACINTOSH RESOURCE

Get super savings on a subscription, plus a FREE CD-ROM.



Incisive Product Reviews  
Lab-based Performance Tests  
Tips, Tricks & Tutorials  
Technical Solutions  
Coverage of Emerging Technology  
And much more!

Macworld is the best way to stay on top of today's fast-changing Macintosh technology. And here's your chance to save big on a subscription, plus get the exclusive Macworld Clip Art CD-ROM containing an extensive collection of images, digital stock photos, and more — FREE with your paid order.

To get it all, go to  
<http://subscribe.macworld.com>



# The Desktop Critic

by David Pogue

## Reality Check 2000

REPORTS OF APPLE'S DEATH, IT TURNS OUT, WERE GREATLY EXAGGERATED

**A** FRIEND RECENTLY e-mailed me a hilarious collection of technology predictions. *Popular Mechanics* in 1949: "Computers in the future may weigh no more than 1.5 tons." Western Union in 1876: "This 'telephone' has too many shortcomings to be seriously considered as a means of communication." And Bill Gates in 1981: "640K ought to be enough for anybody." The moral: If you think you can predict the future of technology, you're a fool.

Yet during Apple's business slump in the mid-1990s, an epidemic of Prediction Flu swept America. Most journalists and analysts were content to report what was actually *happening*, which was dramatic enough. But the following dime-store Nostradamuses felt moved to tell their readers what was *going* to happen. The resulting self-fulfilling effect made it even harder for Apple to recover.

I lost a lot of faith in the media during those dark days. In fact, I started working on this column back then. "If Apple ever comes back," I vowed through clenched teeth, "I'm going to come back to haunt these guys. I'm going dig up and reprint every one of their doomy predictions so readers will never again take these fortune crackers seriously."

Apple did come back, so here I am. If you're a Mac fan, forgive this unpleasant flashback to a nightmarish time. It's for a good cause.

### Time

February 5, 1996: "One day Apple was a major technology company with assets to make any self respecting techno-conglomerate salivate. The next day Apple was a chaotic mess without a strategic vision and certainly no future."

The company with "no future" has since tripled its market share and is raking

in \$12 billion a year. (Bonus fact: The author, a venture capitalist, assesses companies' prospects for a living. Scary.)

### The Boston Globe

May 14, 1998: "[The new iMac] might have done Apple a world of good if it had appeared a few years ago, when far fewer homes had PCs in them. Today, the iMac will only sell to some of the true believers. [It's] clean, elegant, floppy-free—and doomed."

You want doomed, buddy? Try your career as a psychic. Apple sold over *two million* iMacs in the machine's first year,

Microsoft is decomposing. The Next purchase was a masterstroke, landing Apple great people such as Avie Tevanian and Steve Jobs, as well as the software that underlies Mac OS X.

### Fortune

February 19, 1996: "Apple's erratic performance has given it the reputation on Wall Street of a stock a long-term investor would probably avoid."

Depends on what you mean by *long-term*. If you'd bought Apple stock the day *Fortune* published that column, you'd be up about 600 percent right about now.

And then this: "By the time you read this story, the quirky cult company . . . will end its wild ride as an independent enterprise."

For a magazine called *Fortune*, it was pretty lousy at reading Apple's palm.

### Michael S. Malone, Author

March 1999 (in his book *Infinite Loop*): "Market share up, stock up, hot new products rolling out the door, customer pride once again strong, Steve Jobs had once again pulled off a miracle. . . . [But] for all of his success, all Steve Jobs had really accomplished was a temporary pause in Apple's long-term decline."

Poor Mike must have been looking at the graph upside down. Apple's financial, technological, and marketing positions have rocketed skyward every single quarter since he typed those goofy words.

### Wired

June 1997 (from the article "101 Ways to Save Apple"): "1. Admit it. You're out of the hardware game."

Good thing editors don't run companies—what actually saved Apple was hardware, hardware, and hardware.

*continues on page 175*



making it the best-selling personal computer during most of its first 12 months.

### Forrester Research

January 25, 1996: "Whether they stand alone or are acquired, Apple as we know it is cooked. It's so classic. It's so sad."

I'll tell you what's sad. This whopper got quoted in the *New York Times*.

### Nathan Myhrvold, Microsoft Chief Technology Officer

June 1997: "The Next purchase is too little too late. Apple is already dead."

Hey, Nate, if Apple's dead, then



**"With XANTÉ,  
we can truly  
say 'Aloha'  
to work!"**

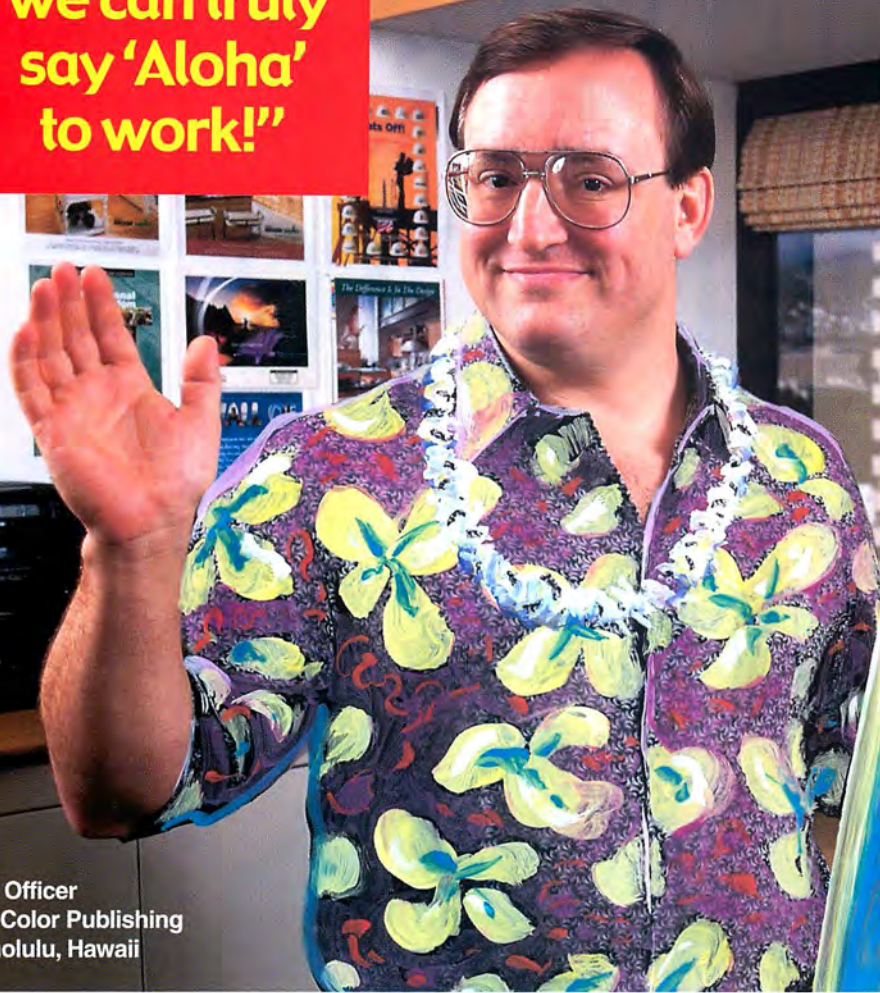

Tim Officer  
For Color Publishing  
Honolulu, Hawaii

"Here in Hawaii, 'Aloha' means both 'hello' and 'goodbye,' which is perfect for us. Ever since our XANTÉ Accel-a-Writer 3G arrived here, we've been saying goodbye to work almost as soon as it hits the door. The speed is amazing, the quality is noticeably high, and our Accel-a-Writer 3G saves us gobs of money. For just pennies a page, I can proof seps and turn out high-res, error-free composites. With our XANTÉ Accel-a-Writer 3G, we really are working in paradise."



The XANTÉ® Accel-a-Writer® 3G • Highest resolution of any printer in its class — up to 2400 x 2400 dpi • Superior halftones with line screens up to 150 lpi • Precision output with XANTÉ's exclusive Graphic Software Package • Greater flexibility with oversized output up to 13" x 35.5" • Fast processing and up to 20 ppm • The perfect solution for final output, camera ready art, proofing or computer-to-film printing

 **XANTÉ**  
Innovative Prepress Solutions

1-800-926-8839, ext. 2163 • Fax: 334-342-3345 • [www.xante.com/mw1](http://www.xante.com/mw1)

©1999 XANTÉ CORPORATION. XANTÉ and Accel-a-Writer are trademarks or registered trademarks of XANTÉ CORPORATION. Adobe, PostScript, PostScript 3, and the PostScript logo are trademarks or registered trademarks of Adobe Systems, Incorporated. Other brands and product names are trademarks or registered trademarks of their respective holders. XANTÉ CORPORATION, Post Office Box 16526, Mobile, AL 36616, tel: 334-342-4840, fax: 334-342-3345.

Circle 112 on card or go to [www.macworld.com/getinfo](http://www.macworld.com/getinfo)



# iMac, therefore iMice.



Say hello to the extended family. Looks aside, personality traits like comfort, functionality, and plug-and-play simplicity are all Kensington. Guess you could say the apple doesn't fall far from the tree... sorry, couldn't resist.

To get the scoop on our USB products for the iMac™ visit [www.kensington.com/imac](http://www.kensington.com/imac) or your favorite iMac dealer.

**KENSINGTON®**

Smart design at work.

Kensington is a registered trademark of ACCO World Corporation. All other registered and unregistered trademarks are the property of their respective owners. iMac is a trademark of Apple Computer, Inc. Kensington sells mice and trackballs that are compatible with Apple's Macintosh computers. No endorsement of these products by Apple Computer, Inc. is intended or implied. ©1999 Kensington Technology Group, a division of ACCO Brands, Inc.

Choose 1 at [www.macworld.com/getinfo](http://www.macworld.com/getinfo)