

WH3700iXLTC

Digital Inverter Generator

3000 Running Watts | 3700 Peak Watts

DO NOT RETURN THIS PRODUCT TO THE STORE

If you have questions or need assistance, please call customer service at 855-944-3571.

INTRODUCTION

TABLE OF CONTENTS

INTRODUCTION

DISCLAIMERS.....2
 ALL RIGHTS RESERVED.....2
 SPECIFICATIONS.....3

SAFETY

SAFETY DEFINITIONS.....4
 SAFETY SYMBOLS4
 SAFETY INSTRUCTIONS.....5
 SAFETY LABELS.....7
 CO SENSOR.....8
 CONTROL PANEL CO AUTO-SHUTOFF8

COMPONENTS

CONTROL PANEL COMPONENTS.....9
 GENERATOR COMPONENTS10
 CARTON CONTENTS.....11

ASSEMBLY

INITIAL OIL FILL.....11
 FUEL.....12

OPERATION

GENERATOR LOCATION.....13
 GROUNDING.....13
 HIGH ALTITUDE OPERATION.....13
 BREAK-IN PERIOD.....14
 FREQUENCY OF USE.....14
 BEFORE STARTING THE GENERATOR14
 STARTING THE ENGINE.....14
 STOPPING THE ENGINE14
 ECO MODE.....15
 AC CIRCUIT BREAKERS15

OVERLOAD RESET.....15
 POWER MANAGEMENT16
 EXTENSION CORDS.....17
 PARALLEL OPERATION.....18
 TRANSPORTING.....18

MAINTENANCE

MAINTENANCE SCHEDULE.....19
 MAINTENANCE REPLACEMENT PARTS.....19
 ENGINE SERVICE COVER19
 AIR FILTER MAINTENANCE19
 ENGINE OIL LEVEL CHECK20
 ENGINE OIL CHANGE.....20
 SPARK PLUG MAINTENANCE.....21
 SPARK ARRESTOR SERVICE21
 STORAGE.....22
 DRAINING THE FUEL TANK22
 VALVE CLEARANCE23
 TROUBLESHOOTING24

EXPLODED VIEWS

EXPLODED VIEWS.....25

SCHEMATICS

SCHEMATICS.....31
ESPAÑOL.....32
FRANÇAIS.....56

⚠ WARNING: Operating, servicing, and maintaining this equipment can expose you to chemicals including engine exhaust, carbon monoxide, phthalates, and lead, which are known to the State of California to cause cancer and birth defects or other reproductive harm. To minimize exposure, avoid breathing exhaust, and wear gloves or wash your hands frequently when servicing this equipment. For more information go to www.P65warnings.ca.gov.

DISCLAIMERS

All information, illustrations, and specifications in this manual were in effect at the time of publishing. The illustrations used in this manual are intended as representative reference views only. We reserve the right to make any specification or design change without notice.

ALL RIGHTS RESERVED

All rights reserved. No reproduction allowed in any form without written permission from Westinghouse Outdoor Power Equipment, LLC.

⚠ DANGER	
	Read this manual before using or performing maintenance on this product. Failure to follow the instructions and safety precautions in this manual can result in serious injury or death.

SAVE THESE INSTRUCTIONS

INTRODUCTION

SPECIFICATIONS

Specifications	
Running Watts:	3000
Peak Watts:	3700
Rated Voltage:	120V
Rated frequency:	60 Hz
Phase:	Single phase
Total Harmonic Distortion:	≤ 3%
Engine Displacement:	150 cc
Starting Type:	Recoil
Fuel Capacity:	1.26 Gallon (4.8 L)
Fuel Type:	87–93 octane*
Oil Capacity:	0.53 US qt (0.5 L)
Oil Type:	10W-30
Spark Plug:	97109 (F7RTC)
Spark Plug Gap:	0.024 – 0.032 in. (0.60 – 0.80 mm)
Valve Intake Clearance:	0.0031 – 0.0047 in. (0.08 – 0.12 mm)
Valve Exhaust Clearance:	0.0051 – 0.0067 in. (0.13 – 0.17 mm)
AC Grounding System:	Floating neutral
Voltage Regulator:	Digital
Alternator Type:	Permanent magnet
Maximum Ambient Temperature:	104°F (40°C)
Certifications:	<ul style="list-style-type: none">• EPA• CARB

*Ethanol content of 10% or less. **DO NOT** use E15 or E85.

NOTICE

This product is designed and rated for continuous operation at ambient temperatures up to 104°F (40°C). If needed, this product can be operated at temperatures ranging from 5°F (15°C)–122°F (50°C) for short periods. If the product is exposed to temperatures outside of this range during storage, it should be brought back within this range before operation. This product must always be operated outdoors in a well-ventilated area and away from doors, windows, and other vents.

Maximum wattage and current are subject to and limited by such factors as fuel BTU content, ambient temperature, altitude, engine conditions, etc. Maximum power decreases about 3.5% for each 1,000 feet above sea level, and will also decrease about 1% for each 10°F (6°C) above 60°F (16°C) ambient temperature.

PRODUCT REGISTRATION

For trouble-free warranty coverage, it is important to register your Westinghouse generator.

You can register by:

- Completing and mailing the product registration card included in the carton.
- Registering your product online at: <https://westinghouseoutdoorpower.com/pages/warranty-registration>
- Scanning the following QR code with your smartphone camera. You will be directed to the mobile registration link.



- Sending the following product information to:

Westinghouse Outdoor Power
Warranty registration
777 Manor Park Drive
Columbus, OH 43228

For Your Records

Date of Purchase: _____

Model Number: _____

Serial Number: _____

Place of Purchase: _____

IMPORTANT: Keep your purchase receipt for trouble-free warranty coverage.

SAFETY

SAFETY

SAFETY DEFINITIONS

The words DANGER, WARNING, CAUTION and NOTICE are used throughout this manual to highlight important information. Make sure that the meanings of this safety information is known to all who operate, perform maintenance on, or are near the generator.



This safety alert symbol appears with most safety statements. It means attention, become alert, your safety is involved! Please read and follow the message that follows the safety alerts symbol.

⚠ DANGER

Indicates a hazardous situation which, if not avoided, will result in death or serious injury.

⚠ WARNING

Indicates a hazardous situation which, if not avoided, could result in death or serious injury.

⚠ CAUTION

Indicates a hazardous situation which, if not avoided, could result in minor or moderate injury.

NOTICE

Indicates a situation which can cause damage to the generator, personal property, and/or the environment, or cause the equipment to operate improperly.

Note: Indicates a procedure, practice or condition that should be followed for the generator to function in the manner intended.

SAFETY SYMBOLS

Follow all safety information contained in this manual and on the generator.

Symbol	Description
	Safety Alert Symbol
	Electrocution Hazard
	Asphyxiation Hazard
	Burn Hazard. DO NOT touch hot surfaces.
	Electrical Shock Hazard
	Fire Hazard
	Maintain Safe Distance
	Lifting Hazard
	Read Manufacturer's Instructions
	DO NOT Operate in Wet Conditions
	Ground. Consult with electrician to determine grounding requirements before operation.

SAFETY INSTRUCTIONS

CORRECT USE

Example location to reduce risk of carbon monoxide poisoning

- ONLY use outside and downwind, far away from windows, doors and vents.
- Direct exhaust away from occupied spaces



INCORRECT USE

DO NOT operate in any of the following locations:

- Near any door, window, or vent
- Garage
- Basement
- Crawl Space
- Living Area
- Attic
- Entry Way
- Porch
- Mudroom

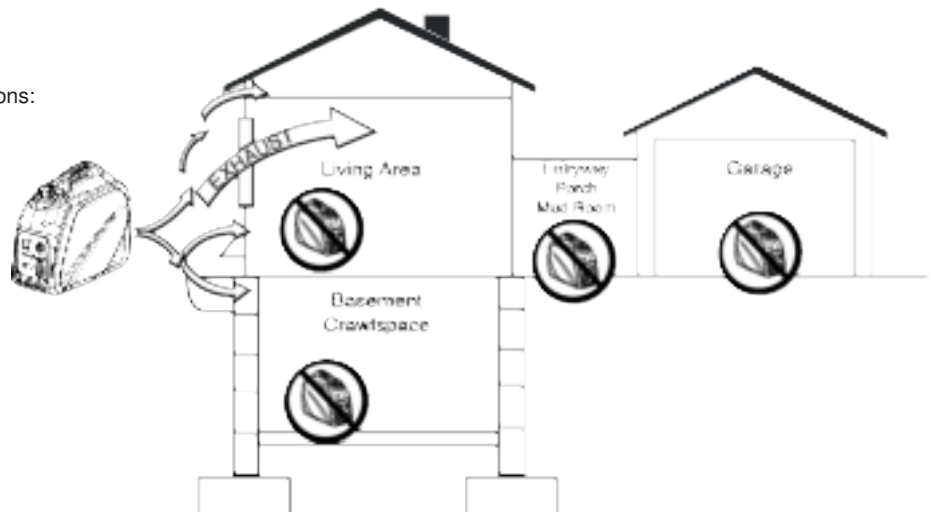

NOTICE

Install battery-powered carbon monoxide detectors or plug-in carbon monoxide detectors with battery back-up in living areas.

⚠ DANGER

Fire and electrocution hazard. **DO NOT** connect to a building's electrical system unless the generator and transfer switch have been properly installed and the electrical output has been verified by a qualified electrician. The connection must isolate the generator power from utility power and must comply with all applicable laws and electrical codes.

⚠ DANGER

Using a generator indoors **CAN KILL YOU IN MINUTES!** (Generator exhaust contains carbon monoxide. This is a poison you cannot see or smell.)



NEVER use inside a home or garage, **EVEN IF** doors and windows are open.



Only use **OUTSIDE** and far away from windows, doors, and vents.

⚠ DANGER

Electrocution hazard. Never use the generator in a location that is wet or damp. Never expose the generator to rain, snow, water spray, or standing water while in use. Protect the generator from all hazardous weather conditions. Moisture or ice can cause a short circuit or other malfunction in the electrical circuit.

SAFETY

GENERAL SAFETY PRECAUTIONS

- Never use the generator to power medical support equipment.
- **DO NOT** operate the generator when you are tired or under the influence of drugs, alcohol, or medication.
- **DO NOT** use generator with electrical cords which are worn, frayed, bare, or otherwise damaged.
- All electrical tools and appliances operated from this generator must be properly grounded by use of a third wire or be double-insulated.
- When this generator is used to supply a building wiring system the generator must be installed by a qualified electrician and connected to a transfer switch as a separately derived system in accordance with NFPA 70, National Electrical Code.
- If you begin to feel sick, dizzy, or weak while using the generator, move to fresh air IMMEDIATELY. See a doctor, as you can have carbon monoxide poisoning.
- Only use OUTSIDE and far away from windows, doors, and vents as recommended by the US Department of Health and Human Services Centers for Disease Control and Prevention. Your specific home and/or wind conditions may require additional distance.
- While operating and storing, keep at least five feet of clearance on all sides of the generator, including overhead. Allow the generator to cool a minimum of 30 minutes before storage. Heat created by the muffler and exhaust gases could be hot enough to cause serious burns and/or ignite combustible objects.
- **DO NOT** touch the muffler or engine. They are very HOT and will cause severe burns. **DO NOT** put body parts or any flammable or combustible materials in the direct path of the exhaust.
- Always remove any tools or other service equipment used during maintenance away from the generator before operating.
- Avoid skin contact with engine oil or gasoline. Wear protective clothing and equipment. Wash all exposed skin with soap and water.
- A transfer switch must be installed by a licensed electrician approved by the authority having jurisdiction. The installation must comply with all applicable laws and electrical codes.

FUEL SAFETY

- Store fuel in a container approved for gasoline.
- **DO NOT** smoke when filling the generator with gasoline.
- **DO NOT** allow the generator's gas tank to overflow when filling.
- Shut down the engine and allow it to cool for five minutes before adding gasoline or oil to the generator.
- Never remove the fuel cap when the generator is running. Shut off the engine and allow the unit to cool at least five minutes. Remove the fuel cap slowly to

release pressure, keep fuel from escaping around the cap, and to avoid the heat from the muffler igniting fuel vapors. Tighten the fuel cap securely after refueling.

- Wipe spilled fuel from the unit.
- Never attempt to burn off spilled fuel.
- Never overfill the fuel tank. Leave room for fuel to expand. Overfilling the fuel tank can result in a sudden overflow of gasoline and result in spilled gasoline coming in contact with HOT surfaces.
- Spilled fuel can ignite. If fuel is spilled on the generator, wipe up any spills immediately. Dispose of rag properly. Allow area of spilled fuel to dry before operating the generator.
- Wear eye protection while refueling.
- Never use gasoline as a cleaning agent.
- Store any containers containing gasoline in a well-ventilated area, away from any combustibles or source of ignition.

GASOLINE AND GASOLINE VAPOR (GAS)

⚠ DANGER

Fire and explosion hazard. Gasoline is highly explosive and flammable and can cause severe burns or death.

- In case of a gas fire, **DO NOT** attempt to extinguish the flame if the fuel valve is in the gas position. Introducing an extinguisher to a generator with an open fuel valve could create an explosion hazard.
- Gas has a distinctive odor, this will help detect potential leaks quickly.
- Gas vapors can cause a fire if ignited.
- Gasoline is a skin irritant and needs to be cleaned up immediately if it comes in contact with the skin.

When starting the generator:

- Make sure that the fuel cap, air filter, spark plug, fuel lines, and exhaust system are properly in place.
- If you spill any gasoline on the tank, allow it to fully evaporate before operating.
- Make sure the generator is on a flat surface before operating.

When transporting or servicing the generator:

- Disconnect the spark plug wire to prevent accidental starting.

When storing the generator:

- Store away from sparks, open flames, pilot lights, heat, and other sources of ignition.
- **DO NOT** store gas near furnaces, water heaters, or any other appliances that produce heat or have automatic ignitions.

SAFETY LABELS

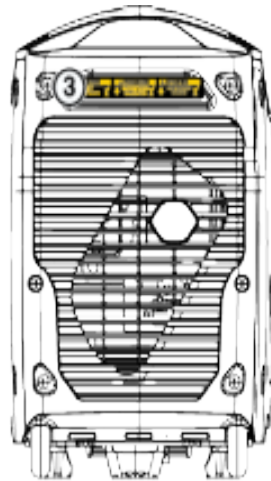
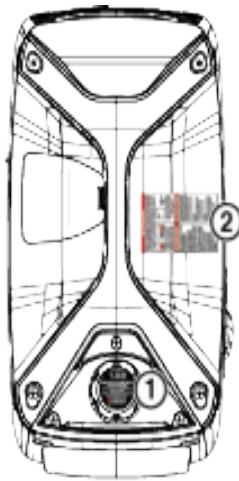

1 DO NOT OVERFILL.
1.3 Gal
4.8 L
USE FUEL STABILIZER FOR STORAGE
 UTILISER UN STABILISATEUR DE CARBURANT POUR LE STOCKAGE
 EL USO DEL ESTABILIZADOR DE COMBUSTIBLE PARA EL ALMACENAMIENTO

ET NEJEDNŮ OKTANE
 ET OCTANE HIGHER
 ET OCTANE HIGHER

3 **CAUTION** **PRECAUCIÓN** **ATTENTION**
HOT SURFACES **SUPERFICIES CALIENTES** **AUX SURFACES CHAUDES**

2 **⚠ DANGER**
USING A GENERATOR INDOORS CAN KILL YOU IN MINUTES. GENERATOR EXHAUST CONTAINS CARBON MONOXIDE. THIS IS A POISON YOU CANNOT SEE OR SMELL.

NEVER USE INSIDE A HOME OR GARAGE, EVEN IF DOORS AND WINDOWS ARE OPEN. **ONLY USE OUTSIDE AND FAR AWAY FROM WINDOWS, DOORS, AND VENTS.**

⚠ DANGER **⚠ PELIGRO**

Utiliser un générateur à l'intérieur PEUT VOUS TUER EN QUELQUES MINUTES. **Si usa un generador en interiores MORIRÁ EN POCOS MINUTOS.** El escape del generador contiene monóxido de carbono. Es un veneno que no tiene olor ni se puede ver.

Les gaz d'échappement du générateur contiennent du monoxyde de carbone. C'est un gaz toxique invisible et inodore. **NE JAMAIS utiliser à l'intérieur d'une maison ou d'un garage, MÊME si les portes et les fenêtres sont ouvertes.** **Utiliser UNIQUEMENT à l'EXTÉRIEUR et loin des fenêtres, portes et ventilations.**

• NEVER use inside a home or garage, EVEN if doors and windows are open. **• NUNCA lo use dentro de una casa o garaje, AUN si las puertas y ventanas están abiertas.** **• Sólo úselo EN EXTERIORES y lejos de ventanas, puertas y ductos de ventilación.**

4 **Westinghouse**

Serial number
 Número de serie
 Número de série

Model: Model: Modelo W447000-7
 Part No. / No. de pieza / No. de pieza 03701
 AC Voltage: Voltaje, Tension 120V
 Power (Starting): Potencia (arranque) / Potencia (arranque) 3000W
 Power (Peak): Potencia (pico) / Potencia (pico) 3700W
 Current (Generator): Actual 25A
 AC Voltage: Voltaje, Tension (continuous) 5V
 Current: Corriente, Actual 240 VA
 Frequency: Frecuencia, La Frecuencia 60Hz
 Phase: Fase, Phase (generator) Single (generator)
 30-Min. Run: Régimen (motor) 2200
 Power Factor: Factor de potencia, Facteur de puissance 1.0
 Total Output: Nivel de aislamiento, Tension (generator)
 Max. Amp. Temp.: Temperatura (temperatura máxima) 40°C (104°F)
 Fuel: Combustible, Carburant 8.5L (22.5qt)
 Fuel Tank Size: Nivel de reserva de combustible, Nivel de reserva 1.5 (4.8 L)
 Oil Capacity: Capacidad en aceite, Capacidad (aceite) 6.1 L (62oz)

⚠ WARNING:
 • Use gasoline with a maximum octane rating of 87.
 • Do not add alcohol based fuels (methanol, denatured alcohol, etc.)
 • Clean and spill oil as required to ensure proper engine performance.
 • When refueling, always stop the engine.
 • Never refuel when the engine is still running.
 • Do not touch or contact cables with wet hands.
 • Do not operate generator inside of tent or other enclosed space.
 • Do not connect AC cables to any power strip.
 • Clean spark arrestor every 50 hours to prevent engine damage.
 • When operating your generator, do not wear any clothes or jewelry which are flammable or made of dry synthetic fiber.

⚠ ADVERTENCIA:
 • Use gasoline with a maximum octane rating of 87.
 • No agregar alcohol a ningún combustible, alcohol o aditivos.
 • Limpiar y eliminar los derrames de aceite como se requiere para garantizar el rendimiento.
 • Siempre apague el motor al repostar.
 • Nunca opere el generador cuando el motor esté corriendo.
 • No toque ni toque los cables con las manos húmedas.
 • No opere el generador dentro de una tienda o espacio cerrado.
 • No conecte los cables AC a ningún enchufe.
 • Limpie el arrestador de chispas cada 50 horas para evitar daños al motor.
 • Cuando opere su generador, no use ropa o joyería que sea inflamable o hecha de fibra sintética seca.

⚠ ATTENTION:
 • Utilisez du gasoline avec un indice d'octane maximum de 87.
 • Ne rajoutez pas d'alcool dans le carburant, alcool ou additifs.
 • Nettoyez et éliminez les déversements d'huile comme requis pour garantir les performances.
 • Arrêtez toujours le moteur avant de rajouter du carburant.
 • Ne touchez pas les câbles avec des mains humides.
 • Ne faites pas fonctionner le générateur à l'intérieur d'une tente ou d'un espace clos.
 • Ne connectez pas les câbles AC à un interrupteur.
 • Nettoyez l'arrestateur de chispes tous les 50 heures pour éviter d'endommager le moteur.
 • Lorsque vous utilisez votre générateur, ne portez pas de vêtements ou de bijoux inflammables ou en fibre synthétique sèche.

Oil: SAE 10W-30 **6.1 L (62oz)**

Read and understand operating instructions before starting. **Lée y comprenda las instrucciones de operación antes de comenzar.** **Lisez et comprenez les instructions d'utilisation avant de commencer.**

Provide proper ventilation. **Do not operate in a confined area.** **Proporcione una ventilación adecuada.** **No opere en un área confinada.** **Assurez une ventilation adéquate.** **N'opérez dans un espace confiné.**

Do not operate in wet conditions. **Do not touch wet fuel and electrical leads.** **Do not operate in wet conditions.** **Do not touch wet fuel and electrical leads.** **Do not operate in wet conditions.** **Do not touch wet fuel and electrical leads.**

FOR USE IN CANADA: RESISTENCIA DEL MOTOR: 1000 WATT. PARA USO EN CANADÁ: POTENCIA DEL MOTOR: 1000 WATT. PARA USO EN CANADÁ: POTENCIA DEL MOTOR: 1000 WATT.

SAFETY

CO SENSOR

The CO Sensor monitors for the accumulation of poisonous carbon monoxide gas around the generator when the engine is running. If increasing levels of CO gas are detected, the CO Sensor automatically shuts down the engine.

The CO Sensor will also detect the accumulation of carbon monoxide from other fuel burning sources used in the area of operation. For example, if the exhaust of fuel burning tools is pointed at a CO Sensor-equipped generator, a shut-off may be initiated due to rising CO levels. This is not an error. Hazardous carbon monoxide has been detected. Move and redirect any additional fuel burning sources to dissipate carbon monoxide away from personnel and occupied buildings.

Note: Remote start-equipped generators must be restarted with the START/STOP button on the control panel after an automatic shut-down occurs.

Generators are intended to be used outdoors, far from occupied buildings and the exhaust pointed away from personnel and buildings. If misused and operated in a location that results in the accumulation of CO, like in a partially enclosed area, the CO Sensor shuts off the engine, notifies the user with a RED indicator light, and directs the user to read the Action Label for steps to take. The CO Sensor **DOES NOT** replace carbon monoxide alarms. Install battery-powered carbon monoxide alarm(s) in your home.

⚠ WARNING

Automatic shutoff accompanied with a flashing RED light in the CO Sensor portion of the control panel is an indication that the generator was improperly located. If you start to feel sick, dizzy, weak, or carbon monoxide detectors in your home indicate an alarm, get to fresh air immediately. Call emergency services. You may have carbon monoxide poisoning.

ACTION LABEL

ACTION LABEL

ETIQUETA DE FUNCIONAMIENTO
ÉTIQUETTE D'ACTION

AUTOMATIC SHUTOFF - YOU MUST:
ETIQUETA DE FUNCIONAMIENTO:
ÉTIQUETTE D'ACTION:

- MOVE GENERATOR TO AN OPEN, OUTDOOR AREA.
- POINT EXHAUST AWAY.
- DON'T RUN GENERATOR IN ENCLOSED AREAS.
- MUEVA EL GENERADOR A UN ÁREA ABIERTA, AL EXTERIOR.
- DIRIGEA EL TUBO DE ESCAPE HACIA AFUERA.
- NO ACTÚE EN ZONAS PARCIALMENTE CERRADAS NI EN ESPACIOS CERRADOS.
- MUEVA EL CALENTADOR HACIA UN ESPACIO ABIERTO AL EXTERIOR.
- NO USE EL GENERADOR EN UN ESPACIO CERRADO NI EN UN ESPACIO PARCIALMENTE CERRADO.
- NO USE EL GENERADOR EN UN ESPACIO CERRADO NI EN UN ESPACIO PARCIALMENTE CERRADO.

WARNING
ADVERTENCIA
AVERTISSEMENT

MOVE TO FRESH AIR.
• GET MEDICAL HELP IF SICK, DIZZY OR WEAK.

• MUEVA AL FRESCO. • OBTÉN AYUDA MÉDICA SI SE SIENTE ENFERMO, MAREADO O DÉBIL.

• MUEVA AL FRESCO. • OBTÉN AYUDA MÉDICA SI SE SIENTE ENFERMO, MAREADO O DÉBIL.

• MUEVA AL FRESCO. • OBTÉN AYUDA MÉDICA SI SE SIENTE ENFERMO, MAREADO O DÉBIL.

• MUEVA AL FRESCO. • OBTÉN AYUDA MÉDICA SI SE SIENTE ENFERMO, MAREADO O DÉBIL.

POINT
ORIENTAR
DIRIGIR

EXHAUST
EL TUBO DE ESCAPE
L'ÉCHAPPEMENT

AWAY
HACIA AFUERA
LOIN DE VOUS

TAMPERING WITH CARBON MONOXIDE SENSOR CIRCUIT RESULT IN HAZARDOUS CONDITIONS
INTERFERENCIA CON EL CIRCUITO DEL SENSOR DE MONÓXIDO DE CARBONO PUEDE RESULTAR EN CONDICIONES PELIGROSAS
L'INTERFÉRENCE AVEC LE CIRCUIT DU CAPTEUR DE MONOXYDE DE CARBONE PEUT RÉSULTER EN DES CONDITIONS DANGEREUSES

CONTROL PANEL CO AUTO-SHUTOFF

CARBON MONOXIDE AUTO-SHUTOFF



SERVICE GENERATOR
REALICE UN SERVICIO
DEL GENERADOR

AUTOMATIC SHUTOFF
SEE MANUAL
CORTE AUTOMÁTICO
(VER EL MANUAL)

CO SENSOR INDICATOR LIGHTS

Color	Description
RED	<p>Carbon monoxide accumulated around the generator. After shut-off, the RED indicator light in the CO Sensor area of the control panel will flash to provide notification that the generator was shut-off due to an accumulating CO hazard. The RED light will flash for at least five minutes after a CO shut-off.</p> <p>Move the generator to an open, outdoor area far away from occupied spaces with exhaust pointed away. Once relocated to a safe area, the generator can be restarted. Introduce fresh air and ventilate the area where the generator had shut down.</p>
YELLOW	<p>A CO sensor system fault occurred. When a system fault occurs, the generator is automatically shut down and the YELLOW indicator light in the CO auto-shutoff area of the control panel will flash to provide notification that a fault has occurred. The YELLOW light will flash for at least five minutes after a fault. The generator can be re-started, but may continue to shutoff. A CO sensor fault can only be diagnosed and repaired by an authorized Westinghouse service center.</p>

COMPONENTS

GENERATOR COMPONENTS

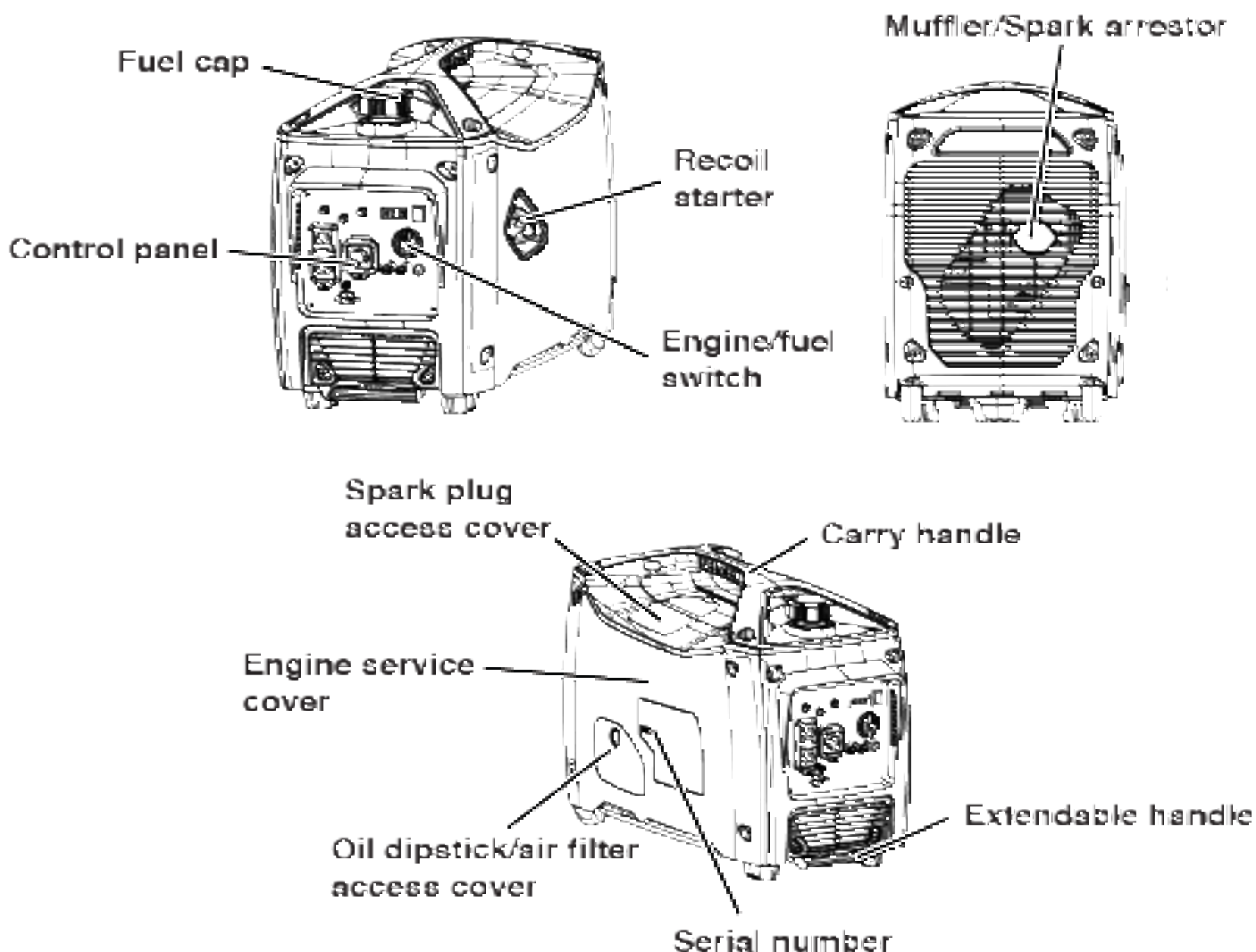

CARTON CONTENTS

1. Carefully open the carton.
2. Remove and save the instruction manual, oil bottle, oil funnel, spark plug socket wrench, and screwdriver.
3. Remove and discard the packing materials.
4. Unfold the top of the plastic bag enclosing the generator.
5. Carefully cut the vertical corners of the carton to access the generator.
6. Recycle or dispose of the packaging materials properly.

CARTON CONTENTS

- User manual
- Quick Start Guide
- Bottle of SAE 10W-30 Oil
- Screwdriver
- Spark plug socket wrench
- Oil Funnel
- L5-30R to TT-30R adapter
- Parallel cord

If any parts are missing, contact our service team at service@wpowereq.com or call 1-855-944-3571.

ASSEMBLY

INITIAL OIL FILL

NOTICE

THIS GENERATOR HAS BEEN SHIPPED WITHOUT OIL. DO NOT attempt to crank or start engine before it has been properly serviced with recommended oil. Failure to add engine oil before starting will result in serious engine damage.

NOTICE

Use of 2-stroke/cycle oil or other unapproved oil types can cause severe engine damage that is not covered under warranty.

The included, recommended oil type for typical use is 10W-30 engine oil. If running the generator in extreme temperatures, refer to the following chart.

Recommended Engine Oil Type								
		10W-30						
	5W-30					10W-40		
	5W-30 Synthetic							
°F	-20	0	20	40	60	80	100	120
°C	-28.9	-17.8	-6.7	4.4	15.6	26.7	37.8	48.9
Ambient temperature								

1. On a level surface, remove the engine service cover and oil dipstick.

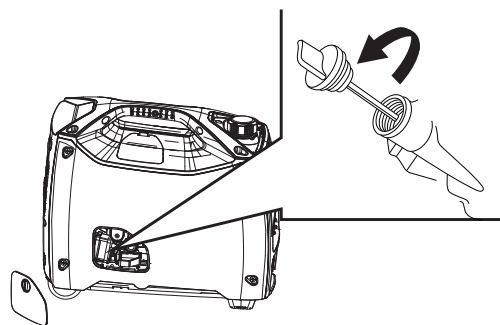

2. Using the supplied funnel and oil, add oil into the engine.

Note: As residual oil from the factory may remain in the engine, add the oil incrementally near the end of the bottle to prevent overfilling the engine. See Engine Oil Level Check in the Maintenance section.

3. Replace the oil dipstick and hand-tighten.
4. Replace the engine service cover.

ASSEMBLY

FUEL

⚠ WARNING

Fire and explosion hazard. Never use a gasoline container, gasoline tank, or any other fuel item that is broken, cut, torn or damaged.

⚠ DANGER

Fire and explosion hazard. **DO NOT** overfill fuel tank. Fill only to the red fill ring located in the in-tank fuel screen filter. Overfilling may cause fuel to spill onto engine causing a fire or explosion hazard.

⚠ DANGER

Fire and explosion hazard. Never refuel the generator while the engine is running. Always turn the engine off and allow the generator to cool for two minutes before refueling.

NOTICE



DO NOT use E15 or E85 fuel in this product. Engine or equipment damage caused by stale fuel or the use of unapproved fuels (such as E15 or E85 ethanol blends) is not covered by warranty. Only use unleaded gasoline containing up to 10% ethanol.

FUEL REQUIREMENTS

- CLEAN, FRESH, unleaded gasoline, 87–93 octane.
- Up to 10% ethanol (gasohol) is acceptable (where available; non-ethanol fuel is recommended).
- **DO NOT** use E85 or E15.
- **DO NOT** use a gas oil mix.
- **DO NOT** modify the engine to run on alternate fuels.
- **DO NOT** fuel indoors.
- **DO NOT** create a spark or flame while fueling.

USING FUEL STABILIZER

Adding a fuel stabilizer (not included) extends the usable life of fuel and helps prevent deposits from forming that can clog the fuel system. Follow the manufacturer's instructions for use.

Always mix the correct amount of fuel stabilizer to gasoline in an approved gasoline container before fueling the generator. Run the generator for five minutes to allow the stabilizer to treat the entire fuel system.

FILLING THE FUEL TANK

1. Turn the generator OFF and allow to cool for a minimum of two minutes before fueling.
2. Place the generator on level ground in a well ventilated area.
3. Clean the area around fuel cap and remove the cap slowly.

NOTICE

Only fill the tank from an approved gasoline container. Make sure the gasoline container is internally clean and in good condition to prevent fuel system contamination.

4. Slowly add the recommended fuel. **DO NOT** overfill. Fill only to the red maximum fill ring on the fuel screen filter visible in the filler neck.

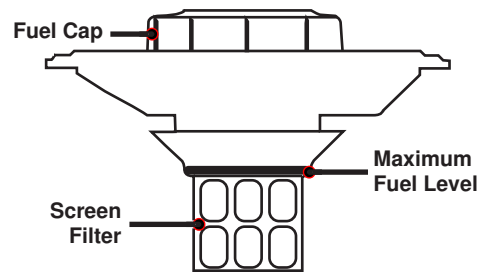

5. Install the fuel cap securely.

NOTICE

Fuel can damage paint and plastic. Use caution when filling the fuel tank. Damage caused by spilled fuel is not covered under warranty.

NOTICE

Clean the fuel screen filter of debris before and after each fueling. Remove the fuel screen filter by slightly compressing it while removing it from the fuel tank.

OPERATION

GENERATOR LOCATION

Read and understand all safety information before starting the generator.

⚠ DANGER

Using a generator indoors CAN KILL YOU IN MINUTES. Generator exhaust contains carbon monoxide. This is a poison you cannot see or smell.



NEVER use inside a home or garage, EVEN IF doors and windows are open.

Only use OUTSIDE and far away from windows, doors, and vents.

NEVER operate the generator inside any building, including garages, basements, crawlspaces, sheds, enclosure, or compartment, including the generator compartment of a recreational vehicle.

⚠ DANGER

Electrocution hazard. Never use the generator in a location that is wet or damp. Never expose the generator to rain, snow, water spray, or standing water while in use. Protect the generator from all hazardous weather conditions. Moisture or ice can cause a short circuit or other malfunction in the electrical circuit. Using a generator or electrical appliance in wet conditions, such as rain or snow, or near a pool or sprinkler system, or when your hands are wet, could result in electrocution.

⚠ WARNING

Fire hazard. Only operate the generator on a solid, level surface. Operating the generator on a surface with loose material such as sand or grass clippings can cause debris to be ingested by the generator that could block cooling vents or the air intake system. Allow the generator to cool for 30 minutes before transport or storage.

The generator should be on a flat, level surface at all times (Even while not in operation). The generator must have at least 5 ft. (1.5 m) of clearance from all combustible material.

DO NOT operate the generator in the back of a SUV, camper, trailer, truck bed (regular, flat, or otherwise), under stairs, next to walls or buildings, or in any other location that will not allow for adequate cooling of the generator and/or the muffler. **DO NOT** contain generators during operation.

⚠ DANGER

Asphyxiation hazard. Place the generator in a well-ventilated area. **DO NOT** place the generator near vents or intakes where exhaust fumes could be drawn into occupied or confined spaces. Carefully consider wind and air currents when positioning generator.

GROUNDING

⚠ WARNING

Shock hazard. Failure to properly ground the generator can result in electric shock.

The generator neutral is floating. The generator ground terminal is connected to the frame of the generator, the metal non-current-carrying parts of the generator, and the ground terminals of each receptacle. The generator (stator winding) is isolated from the frame and from the AC receptacle ground pin. Electrical devices that require a grounded receptacle pin connection may not function properly.

If this generator will be used only with cord and plug equipment connected to the receptacles mounted on the generator, National Electric Code does not require that the unit be grounded. However, other methods of using the generator may require grounding to reduce the risk of shock or electrocution.

NOTICE

Only use grounded 3-prong extension cords, tools, and appliances, or double-insulated tools and appliances.

Before using the ground terminal, consult a qualified electrician, electrical inspector, or local agency having jurisdiction for local codes or ordinances that apply to the intended use of the generator.

HIGH ALTITUDE OPERATION

Engine power is reduced the higher you operate above sea level. Output will be reduced approximately 3.5% for every 1000 feet of increased altitude from sea level.

High altitude adjustment is required for operation at altitudes over 5,000 ft. (1524 m). Operation without this adjustment will cause decreased performance, increased fuel consumption, and increased emissions. Operation of the engine at altitudes below 2,000 ft. (762 m) with the high altitude kit is not recommended.

NOTICE

Do not operate the generator at altitudes below 2,000 ft. (762 m) with the high altitude kit installed. Engine damage may occur.

High Altitude Carburetor Kit: Part# 518517

OPERATION

BREAK-IN PERIOD

For proper break-in, **DO NOT** exceed 50% of the rated running watts (1500 watts) during the first five hours of operation.

Vary the load occasionally to allow stator windings to heat and cool and help seat the piston rings.

FREQUENCY OF USE

If the generator will be used on an infrequent or intermittent basis (more than one month before next use), refer to the Storage section of this manual for information regarding fuel deterioration.

BEFORE STARTING THE GENERATOR

Verify that:

- The generator is placed in a safe, appropriate location.
- The generator is on a dry, flat, and level surface.
- The engine is filled with oil.
- Gasoline is in the fuel tank.
- All loads are disconnected.
- The ECO switch is in the OFF position.

⚠ DANGER

Fire and explosion hazard. **DO NOT** move or tip the generator during operation.

STARTING THE ENGINE

1. Turn the fuel cap vent to the ON position.

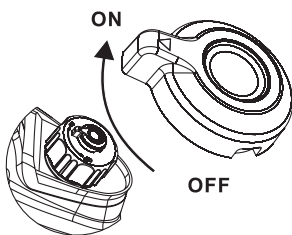

2. Turn the engine/fuel switch to the Choke position.

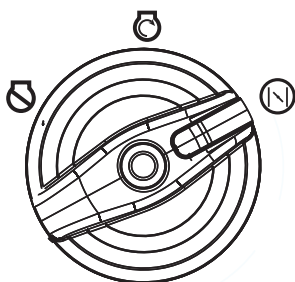

Note: The generator can be started from the Run position if warm from operation.

3. Firmly grasp and pull the recoil handle slowly until you feel increased resistance, then pull rapidly.

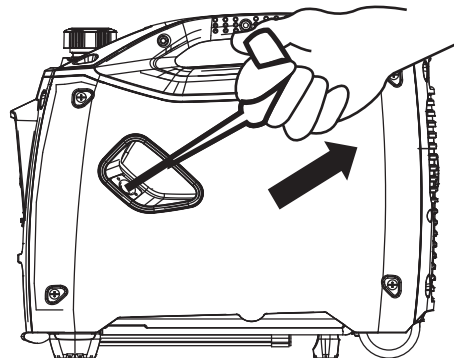

4. After the engine starts, turn the fuel switch to the RUN position.

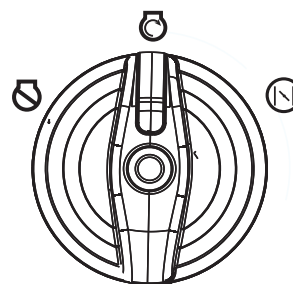

STOPPING THE ENGINE

1. Turn OFF and unplug all connected electrical loads. Never start or stop the generator with electrical devices plugged in or turned on.
2. Let the generator run with no load for several minutes to stabilize internal temperatures of the engine and generator.
3. Turn the engine/fuel switch to the OFF position.
4. Allow the engine to cool, then turn the fuel cap vent to the OFF position.

Note: If there is an emergency and the inverter must be stopped quickly, immediately move the fuel switch to the OFF position.

ECO MODE

NOTICE

Always start the generator with ECO MODE OFF. Allow the engine speed to stabilize and the OUTPUT READY LED to illuminate before switching ECO MODE ON.

ECO MODE
COMBUSTIBLE
EFICIENTE
COMMUTATEUR
D'ÉCONOMIE

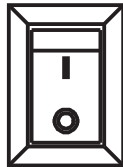

ECO MODE minimizes fuel consumption and noise by adjusting the engine RPM to the minimum required for the current load.

Turn ECO MODE ON when powering small appliances with continuous loads such as a computer or electric light.

Turn ECO MODE OFF when powering large surge loads such as an air conditioner or electric pump.

To turn on ECO MODE, verify that the OUTPUT READY LED is illuminated green, then push the switch to the ON position. If no load is present, the generator RPM will drop to idle speed. The generator will detect loads as they are applied and increase engine RPM.

To run the generator at maximum power and RPM, push the ECO MODE switch to the OFF position.

AC CIRCUIT BREAKERS

The circuit breakers will automatically switch OFF if there is a short circuit, a significant overload of the generator at a receptacle.

If the AC circuit breaker switches OFF automatically, check that the appliance is working correctly and it does not exceed the rated load capacity of the circuit before resetting the circuit breaker.

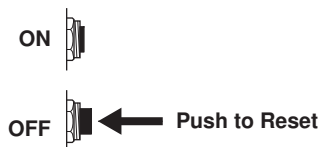

OVERLOAD RESET

The generator will automatically switch OFF all AC output to protect the generator if overloaded or if there is a short circuit in a connected appliance. However, the engine will continue to run. Marginal overloading that temporarily illuminates the OVERLOAD LED may shorten the service life of the generator.

OVERLOAD on the control panel will illuminate red and the green OUTPUT READY will be OFF.

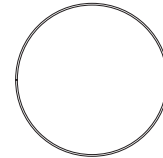

RESET
REINICIAR
RÉINITIALISER

To restore AC output:

1. Turn OFF and unplug all connected electrical loads.
2. Push the RESET button on the control panel until the OVERLOAD LED goes OFF and the OUTPUT READY LED is illuminated.
3. Reset the circuit breakers if OFF.
4. Verify that the intended running and peak loads **DO NOT** exceed the generator's capacity.
5. Reconnect electrical loads sequentially, allowing the generator to stabilize after each load is connected.

OPERATION

GENERATOR CAPACITY

NOTICE

DO NOT overload the generator's capacity. Exceeding the generator's wattage/ampere capacity can damage the generator and/or electrical devices connected to it.

Make sure the generator can supply enough continuous (running) and surge (starting) watts for the items you will power at the same time.

The total power requirements (Volts x Amps = Watts) of all appliances connected must be considered. Appliance and power tool manufacturers usually list rating information near the model or serial number.

To determine power requirements:

1. Select the items you will power at the same time.
2. Total the continuous (running) watts of these items. This is the amount of power the generator must produce to keep the items running. See the wattage reference chart on the next page.
3. Estimate how many surge (starting) watts you will need. Surge wattage is the short burst of power needed to start electric motor-driven tools or appliances such as a circular saw or refrigerator. Because not all motors start at the same time, total surge watts can be estimated by adding only the item(s) with the highest additional surge watts to the total rated watts from step 2.

Example:

Tool or Appliance	Running Watts*	Starting Watts*
TV (Tube Type)	300	0
RV Refrigerator	180	600
Radio	200	0
Light (75 Watts)	300	0
Coffee Maker	600	0
	1580 Total Running Watts*	600 Highest Starting Watts*
	Total Running Watts	1580
	Highest Starting Watts	+ 600
	Total Starting Watts Needed	2180

*Wattages listed are approximate. Verify actual wattage.

POWER MANAGEMENT

To prolong the life of the generator and attached devices, use care when adding electrical loads to the generator. There should be nothing connected to the generator outlets before starting the engine. The correct and safe way to manage generator power is to sequentially add loads as follows:

1. With nothing connected to the generator, start the engine as described in this manual.
2. Plug in and turn on the first load, preferably the largest load you have.
3. Permit the generator output to stabilize (engine runs smoothly and attached device operates properly).
4. Plug in and turn on the next load.
5. Again, permit the generator to stabilize.
6. Repeat steps 4 and 5 for each additional load.

Wattage Reference

Tool or Appliance	Estimated Running Watts*	Estimated Starting Watts*
Incandescent Lights (4 Quantity x 75 Watts)	300	0
TV (Tube Type)	300	0
Sump Pump (1/3 hp)	800	1300
Refrigerator or Freezer	700	2200
Well Pump (1/3 hp)	1000	2000
Radio	200	0
Drill (3/8", 4 amps)	440	600
Circular Saw (Heavy Duty, 7-1/4")	1400	2300
Miter Saw (10")	1800	1800
Table Saw (10")	2000	2000

*Wattages listed are approximate. Verify actual wattage.

EXTENSION CORDS

▲ WARNING

Asphyxiation hazard. Extension cords running directly into the home increase the risk of carbon monoxide poisoning through any openings. If an extension cord running directly into your home is used to power indoor items, there is a risk of carbon monoxide poisoning to people inside the home. Always use battery-powered carbon monoxide detector (s) that meet current UL 2034 safety standards when running the generator. Regularly check the detector (s) battery.

▲ WARNING

Asphyxiation hazard. When operating the generator with extension cords, make sure the generator is located in an open, outdoor area, at least 20 ft. (6 m.) from occupied spaces with exhaust pointed away.

▲ WARNING

Fire and electrocution hazard. Never use worn or damaged extension cords. Damaged or overloaded extension cords could overheat, arc, and burn resulting in death or serious injury.

Before connecting an AC appliance or power cord to the generator:

- Use grounded 3-prong extension cords, tools, and appliances, or double-insulated tools and appliances.
- Make sure the tool or appliance is in good working order. Faulty appliances or power cords can create a potential for electric shock.
- Make sure the electrical rating of the tool or appliance does not exceed the rated power of the generator or the receptacle being used.

EXTENSION CORD SIZING

Only use grounded 3-prong extension cords marked for outdoor use that are rated for the electrical load.

Total Amperage	Minimum Gauge, Outdoor Rated	
	Up to 50 FT (15 M)	Up to 100 FT (30 M)
Up to 10A	12	8
Up to 15A	10	8
Up to 20A	10	6
Up to 30A	8	6
Up to 35A	6	6

OPERATION

PARALLEL OPERATION

⚠ WARNING

Fire and electrocution hazard. Never connect or disconnect the parallel cord leads when a generator is running.

⚠ CAUTION

Correct connection of the left and right cables is very important when the generators are used with a transfer switch to supply power to a building. To avoid serious personal injury or damage to electrical devices, including the generators, do not try to power an electrical system in a building without using an approved transfer switch.

NOTICE

Connecting to a generator that is not compatible can cause a low voltage output that can damage tools and appliances powered by the generator.

Parallel operation gives you the ability to link to a compatible Westinghouse Inverter Generator with the included parallel cord for combined running and peak power output.

A Westinghouse 507PC parallel cord (purchased separately) is also compatible. This cord can be purchased from an authorized Westinghouse Generator dealer.

Note: Compatible Westinghouse generators without parallel ports can be operated in parallel with the receptacle-mounted parallel cable, Part# 260041.

NOTICE

DO NOT use ECO MODE during parallel operation if powering large surge loads such as an air conditioner or electric pump. Engine rpm may not adjust quickly enough to provide the voltage requirements of large surge loads, causing damage to the devices or the generators.

1. On both generators, make sure the engine/fuel switch and the ECO MODE switch are in the OFF position.

2. Connect two parallel cable leads to the parallel outlets on the first generator, then connect the opposite cable leads to the other generator's parallel outlets.

Note: If powering devices directly from the generators (not connected to a building's transfer switch), you do not need to match the left/right cables to the generator's parallel outlets.

3. Start one of the generators and wait until the OUTPUT READY LED illuminates.

4. Start the second generator and wait until the OUTPUT READY LED illuminates before connecting a load.

5. Connect additional loads as described in Power Management section.

6. Unplug all loads before stopping the generators.

TRANSPORTING

- Allow the generator to cool a minimum of 30 minutes before transporting.
- Replace all protective covers on the generator control panel.
- Only use the generator's fixed handle to lift the unit or attach any load restraints such as ropes or tie-down straps. **DO NOT** attempt to lift or secure the generator by holding onto any of its other components.
- Keep the unit level during transport to minimize the possibility of fuel leakage or, if possible, drain the fuel or run the engine until the fuel tank is empty before transport.
- Use the extendable handle for one-person, hand transport. To deploy the handle, push on the handle locking button and pull on the handle until it's fully extended. To stow it, push on the locking button and push on the handle until it's fully retracted. Only extend or retract the handle while the generator is OFF, stationary, and resting on a horizontal surface. **DO NOT** use the extendable handle to lift the generator entirely off the ground, tow it, or up-end it.

⚠ CAUTION



Fire hazard. **DO NOT** fully up-end the generator. Fuel or oil can leak and damage to the generator may occur.

MAINTENANCE

MAINTENANCE SCHEDULE

Regular maintenance will improve performance and extend the service life of the generator. Follow the hourly or calendar intervals, whichever occurs first. More frequent service is required when operating in adverse conditions as noted below.

Before Each Use
Check engine oil
After First 25 Hours or First Month
Change engine oil
After 50 Hours or Every 6 Months
Change engine oil ¹ Clean air filter ²
After 100 Hours or Every 6 Months
Inspect/clean spark arrestor Inspect/clean spark plug Inspect/adjust valve clearance ³
After 300 Hours or Every Year
Replace spark plug Replace air filter

- ¹ Change oil every month when operating under heavy load or in high temperatures.
- ² Clean more often under dirty or dusty conditions. Replace air filter if it cannot be adequately cleaned.
- ³ Recommend service to be performed by authorized Westinghouse service dealer.

MAINTENANCE REPLACEMENT PARTS

Description	Part Number
Air filter	2034
Spark arrestor	6789
Spark plug	97109 (F7RTC)

ENGINE SERVICE COVER

Remove the engine service cover to access the air filter and carburetor. Remove the cover screws then carefully pull the cover out with both hands.

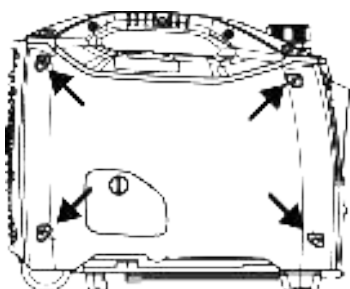

AIR FILTER MAINTENANCE

▲ WARNING

Fire hazard. Never use gasoline or other flammable solvents to clean the air filter. Use only household detergent soap to clean the air filter.

The air filter must be cleaned after every 50 hours of use or six months (frequency should be increased if the generator is operated in a dusty environment).

1. Place the generator on a level surface and allow the engine to cool for several minutes.
2. Remove the engine service cover.
3. Remove the screw securing the air cleaner cover and remove the cover.

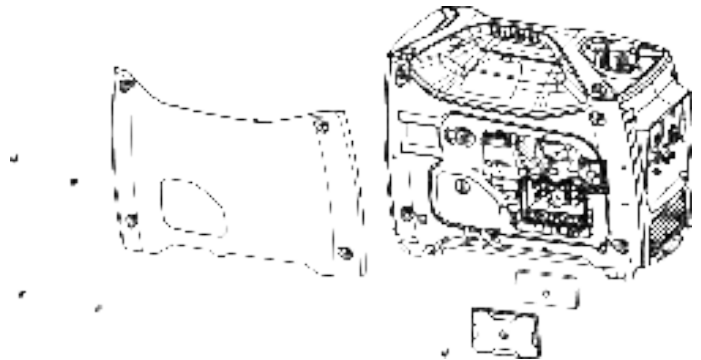

Note: The air filter element is oil soaked. Use an appropriate cleaning container.

NOTICE

Avoid skin contact with engine oil. Wear protective clothing and equipment. Wash all exposed skin with soap and water.

4. Remove the foam air filter from the air cleaner housing and wash it by submerging the element in a solution of household detergent soap and warm water. Slowly squeeze the foam to thoroughly clean.

NOTICE

DO NOT twist or tear the foam air filter element during cleaning or drying. Only apply slow but firm squeezing action.

5. Rinse the air filter element by submerging it in fresh water and applying a slow squeezing action. Allow the filter to dry thoroughly.

NOTICE

DO NOT pollute. Follow the guidelines of the EPA or other governmental agencies for proper disposal of hazardous materials. Consult local authorities or reclamation facility.

6. Dip the foam air filter in clean engine oil then squeeze

MAINTENANCE

out all excess oil. The engine will smoke when started if too much oil is left in the filter.

7. Install the foam air filter in the housing and reinstall the air cleaner cover.
8. Install the engine service panel.

ENGINE OIL LEVEL CHECK

⚠ CAUTION

Avoid skin contact with engine oil. Wear protective clothing and equipment. Wash all exposed skin with soap and water.

NOTICE

Always use the specified engine oil. Failure to use the specified engine oil can cause accelerated wear and/or shorten the life of the engine.

Change the oil more frequently when using the generator in dusty conditions or in extremely hot weather.

Ambient air temperature will affect engine oil performance. Change the type of engine oil used based on weather conditions.

Recommended Engine Oil Type									
		10W-30							
	5W-30					10W-40			
	5W-30 Synthetic								
°F	-20	0	20	40	60	80	100	120	
°C	-28.9	17.8	6.7	4.4	15.6	26.7	37.8	48.9	
	Ambient temperature								

Check the engine oil level before each use or every 8 hours of operation.

1. Place the generator on a level surface and allow the engine to cool for several minutes.
2. Remove the oil access cover.
3. With a damp rag, clean around the oil dipstick.
4. Remove the oil dipstick and wipe the dipstick clean.

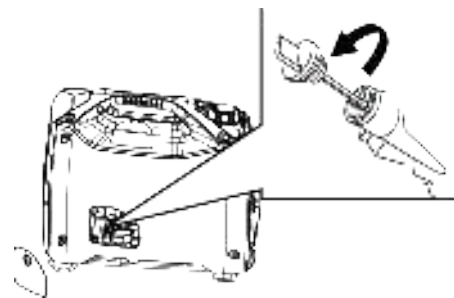

5. Insert the dipstick into the filler neck without screwing it in. Remove the dipstick and verify that the oil level is within safe operating range.



6. If low, add recommended engine oil incrementally and recheck until the level is between the L and H marks on the dipstick. **DO NOT** overfill. If over the full mark on dipstick, drain the oil to reduce oil level to the full mark on dipstick.

7. Replace the oil dipstick and hand-tighten.

8. Install the access cover.

ENGINE OIL CHANGE

⚠ WARNING

Accidental start-up. Remove the spark plug boot from the spark plug when working on the generator.

When using the generator under extreme, dirty, dusty conditions or in extremely hot weather, change the oil more frequently. Change the oil while the engine is still warm from operation.

1. Place the generator on a level surface and allow the engine to cool for several minutes.

Note: Placing the generator on a raised surface slightly above the oil pan will facilitate draining.

2. Remove the oil access cover and spark plug cover. Disconnect the spark plug boot from the spark plug and place the wire where it cannot contact the spark plug.
3. With a damp rag, clean around the oil dipstick. Remove the dipstick and wipe clean.
4. Place an oil pan (or suitable container) under the oil fill/drain hole.
5. Tilt the generator to drain the oil.

6. Slowly pour oil into the oil fill opening until oil the level is between the L and H marks on the dipstick. Stop frequently to check the oil level. **DO NOT** overfill.

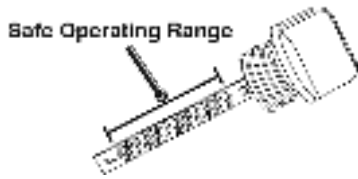

Maximum oil capacity: 0.53 US qt (0.5 L)

7. Replace the dipstick and hand-tighten.
8. Connect the spark plug wire and install the oil access cover.

NOTICE

DO NOT pollute. Follow the guidelines of the EPA or other governmental agencies for proper disposal of hazardous materials. Consult local authorities or reclamation facility.

SPARK PLUG MAINTENANCE

Inspect and clean the spark plug after every 100 hours of use or six months. Replace the spark plug after 300 hours of use or every year.

1. Place the generator on a level surface and allow the engine to cool.
2. Remove the spark plug cover.
3. Remove the spark plug boot by firmly pulling the spark boot directly away from the engine.
4. Clean the area around the spark plug.
5. Remove the spark plug with the included spark plug socket wrench.

NOTICE

Never apply any side load or move the spark plug laterally when removing the spark plug.

6. Inspect the spark plug. Replace if electrodes are pitted, burned, or the insulator is cracked. Only use a recommended replacement plug.
7. Measure the spark plug electrode gap with a wire-type feeler gauge. If necessary, correct the gap by carefully bending the side electrode.

Spark plug gap: 0.024 - 0.032 in. (0.60 - 0.80 mm)

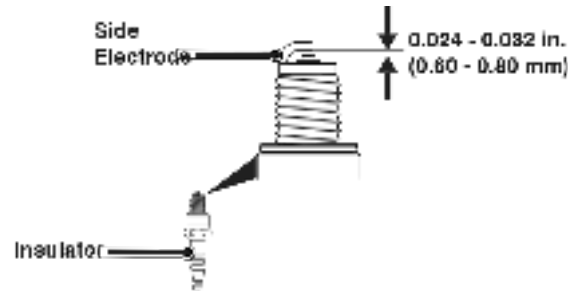

8. Carefully install the spark plug finger tight, then tighten as additional 3/8 to 1/2 turn with the spark plug wrench.
9. Install the spark plug boot and engine service cover.

SPARK ARRESTOR SERVICE

Allow the muffler to cool completely before servicing the spark arrester. Check and clean the spark arrester after every 100 hours of use or six months. Failure to clean the spark arrester will result in degraded engine performance.

1. Place the generator on a level surface.
2. Remove the cover screws and the muffler cover. Use a screw driver to remove the spark arrester.

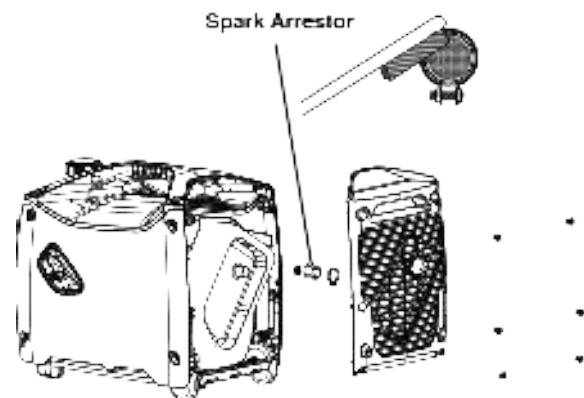

3. Carefully remove the carbon deposits from the spark arrester screen with a wire brush. The spark arrester must be free of breaks and tears. Replace the spark arrester if damaged.
4. Reinstall the spark arrester and muffler cover.

MAINTENANCE

STORAGE

Proper storage preparation is required for trouble-free operation and generator longevity.

NOTICE

Gasoline stored for as little as 30 days can deteriorate, causing gum, varnish, and corrosive buildup in fuel lines, fuel passages and the engine. This corrosive buildup restricts the flow of fuel, which can prevent the engine from starting after a prolonged storage period. The use of fuel stabilizer significantly increases the storage life of gasoline. Full-time use of fuel stabilizer is recommended. Follow the manufacturer's instructions for use.

STORAGE TIME	RECOMMENDED PROCEDURE
Less than 1 month	No service required.
2 to 6 months	Fill with fresh gasoline and add gasoline stabilizer. Drain the carburetor float bowl.
6 months or longer	Drain the fuel tank and carburetor float bowl.

SHORT TERM STORAGE

- Allow the generator to cool a minimum of 30 minutes before storage.
- Replace all protective covers on the generator control panel.
- Wipe the generator with a moist cloth. Clean any debris from the air inlets on the front of the unit and muffler cooling vents.
- Store the generator in a well-ventilated, dry location away from sparks, open flames, pilot lights, heat, and other sources of ignition such as areas with a spark-producing electric motor or where power tools are operated.
- **DO NOT** store the generator or gasoline near furnaces, water heaters, or any other appliances that produce heat or have automatic ignitions.
- With the engine and exhaust system cool and all surfaces dry, cover the generator to keep out dust. **DO NOT** use a plastic sheet as a dust cover. Non-porous materials trap moisture and promote rust and corrosion.

LONG TERM STORAGE

Even properly stabilized fuel can leave residue and cause corrosion if left long term. If storing the generator for two to six months, drain the float bowl to prevent gum and varnish buildup in the carburetor.

DRAINING THE FLOAT BOWL

1. Turn the fuel tank valve to the OFF position.
2. Locate the drain screw on the bottom of the carburetor float bowl.

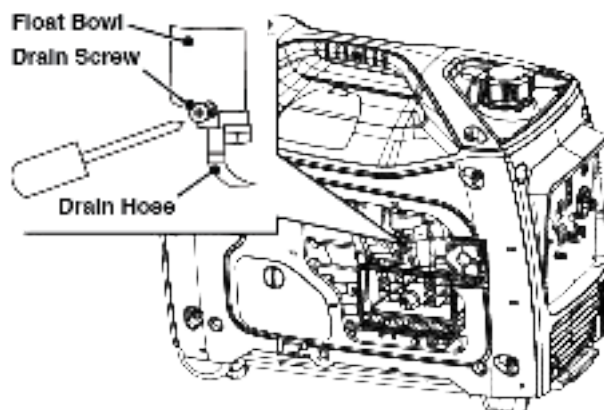

3. Place an appropriate gasoline container under the drain screw to catch the drained fuel.
4. Loosen the float bowl drain screw and allow the fuel to drain. Tighten the float bowl drain screw.

DRAINING THE FUEL TANK

If storing the generator for longer than six months, drain the fuel tank to prevent fuel separation, deterioration, and deposits in the fuel system.

1. Unscrew the fuel tank cap. Remove the fuel screen filter.
2. Using a commercially available gasoline hand pump (not included), siphon the gasoline from the fuel tank into an approved gasoline container. **DO NOT** use an electric pump.
3. Reinstall the fuel screen filter and the fuel tank cap.
4. Start the generator and allow it to run until the generator engine stops.
5. Remove the spark plug.
6. Put a teaspoon of engine oil into the cylinder and pull the recoil handle until resistance is felt. At this position the piston is coming up on its compression stroke and both valves are closed. Storing the engine in this position will help prevent internal corrosion. Return the recoil handle gently.
7. Reinstall the spark plug. Leave the spark plug boot disconnected to prevent accidental starting.
8. Install the engine service cover.

VALVE CLEARANCE

NOTICE

Checking and adjusting valve clearance must be done when the engine is cold.

1. Remove the rocker arm cover and carefully remove the gasket. If the gasket is torn or damaged, it must be replaced.
2. Remove the spark plug so the engine can be rotated more easily.
3. Rotate the engine to top dead center (TDC) by pulling the recoil handle slowly. Looking through the spark plug hole, the piston should be at the top (both valves are closed).
4. Both the rocker arms should be loose at TDC on the compression stroke. If they are not, rotate the engine 360°.
5. Insert a feeler gauge between the rocker arm and the valve stem to measure valve clearance.

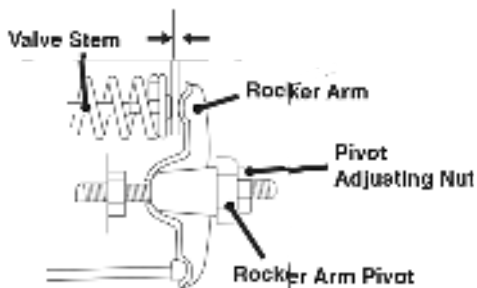

	Intake Valve	Exhaust Valve
Valve Clearance	0.0031 – 0.0047 in. (0.08 – 0.12 mm)	0.0051 – 0.0067 in. (0.13 – 0.17 mm)
Torque	8–12 N•m	8–12 N•m

6. If an adjustment is necessary, hold the rocker arm pivot and loosen the pivot adjusting nut.
7. Turn the rocker arm pivot to obtain the specified clearance. Hold the rocker arm pivot and re-tighten the pivot adjusting nut to the specified torque.

Torque: 106 inch-pound (12 N•m)

8. Perform this procedure for the other valve.
9. Install the gasket, rocker arm cover, and spark plug.

TROUBLESHOOTING

TROUBLESHOOTING

PROBLEM	POSSIBLE CAUSE	CORRECTION
Engine will not start	Out of fuel.	Refuel.
	Bad fuel, generator stored without treating or draining gasoline, or refueled with bad gasoline.	Drain the fuel tank. Refuel with fresh gasoline.
	Dirty air filter.	Clean the air filter.
	Low engine oil level stopped generator.	If low oil LED illuminated, turn battery switch to the OFF position. Add engine oil.
	Spark plug wet with fuel (flooded engine).	Wait five minutes. Turn battery switch to the OFF position. Pull recoil handle rapidly several times. If the generator does not start, remove spark plug and dry.
	Spark plug faulty, fouled, or improperly gapped.	Gap or replace the spark plug. Reinstall.
	Fuel filter restricted, fuel system malfunction, fuel pump failure, ignition malfunction, valves stuck, etc.	Contact Westinghouse customer service toll-free at 1 (855) 944-3571.
	Choke partially open or closed due to weak or disconnected battery.	Manually set the choke. See Maintenance section.
	CO sensor removed or modified.	Return to original configuration.
Engine starts, then shuts down	Out of fuel.	Refuel.
	Incorrect engine oil level.	Check engine oil level.
	Dirty air filter.	Clean the air filter.
	Contaminated fuel.	Drain the fuel tank. Refuel with fresh gasoline.
	Defective low oil level switch.	Contact Westinghouse customer service toll-free at 1 (855) 944-3571.
	CO sensor activated or system fault occurred.	Relocate generator / Contact Westinghouse customer service toll-free at 1 (855) 944-3571.
Engine lacks power	Air filter restricted.	Clean or replace air filter.
	Bad fuel, generator stored without treating or draining gasoline, or refueled with bad gasoline.	Drain the fuel tank. Refuel with fresh gasoline.
	Fuel filter restricted, fuel system malfunction, fuel pump failure, ignition malfunction, valves stuck, etc.	Contact Westinghouse customer service toll-free at 1 (855) 944-3571.
Engine runs rough or bogs when load applied	Dirty air filter.	Clean the air filter.
	Generator overloaded.	Unplug some devices.
	Faulty power tool or appliance.	Replace or repair tool or appliance. Stop and restart the engine.
	Fuel filter restricted, fuel system malfunction, fuel pump failure, ignition malfunction, valves stuck, etc.	Contact Westinghouse customer service toll-free at 1 (855) 944-3571.
No power at AC receptacles	OUTPUT READY LED is OFF and OVERLOAD LED is ON.	Check AC load. Stop and restart engine. Check the air inlet. Stop and restart the engine.
	AC circuit breaker/s tripped.	Check AC loads and reset circuit breaker/s.
	Faulty power tool or appliance.	Replace or repair tool or appliance. Stop and restart the engine.
	Faulty generator.	Contact Westinghouse customer service toll-free at 1 (855) 944-3571.

EXPLODED VIEW

EXPLODED VIEW AND PARTS LIST

EXPLODED VIEW A

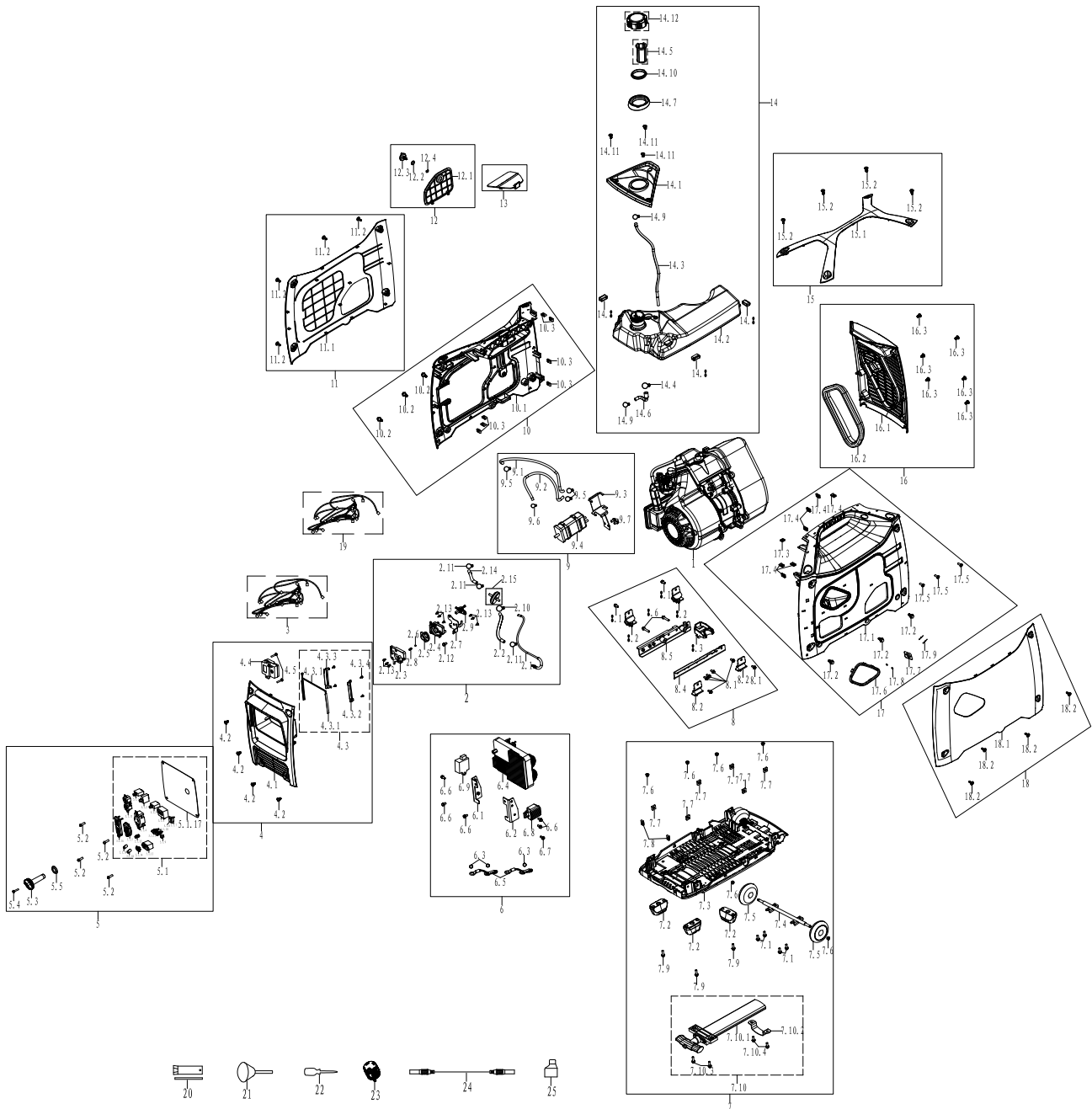

EXPLODED VIEW

EXPLODED VIEW A

NO.	PART#	DESCRIPTION
1	1148149110009	ENGINE
2		FUEL SWITCH ASSEMBLY
2.1	500746	CABLE
2.2	500747L	FUEL LINE
2.3	500512	FRONT COVER
2.4	500513	REAR COVER
2.5	500514	CABLE TRAY
2.6	500003	STEEL BALL
2.7	500089	FUEL SWITCH BRACKET
2.8	500012	SPRING
2.9	503062	FUEL SWITCH
2.10	94411	FUEL LINE CLAMP
2.11	94423	FUEL LINE CLAMP
2.12	91325	BOLT M6
2.13	92110	SCREW ST
2.14	95964L	FUEL LINE
2.15	516401	FILTER
3	500759	DEPUTY WIRING HARNESS
4		PANEL REAR COVER ASSEMBLY
4.1	9218	PANEL REAR COVER
4.2	92078	SCREW M6
4.3		LIGHT STRIP ASSEMBLY
4.3.1	9219	LIGHT STRIP
4.3.2	9220	RIGHT LIGHT STRIP FIXED PLATE
4.3.3	9221	LEFT LIGHT STRIP FIXED PLATE
4.3.4	92235	SCREW ST
4.4	599070	CO MODULE
4.5	92328	BOLT M4
5		PANEL ASSEMBLY
5.1	504008	PANEL ASSEMBLY
5.1.1	9227-20	THERMAL PROTECTOR
5.1.2	9227-25	THERMAL PROTECTOR
5.1.3	9227-30	THERMAL PROTECTOR
5.1.4	6383	L5-30R RECEPTACLE
5.1.5	6847	DUST COVER
5.1.6	9178	IGNITER
5.1.7	9224	ECO SWITCH
5.1.8	9079	WATERPROOF CAP
5.1.9	9230	VOLTAGE RESET SWITCH
5.1.10	9232	PARRALLEL SOCKET
5.1.11	9122	DUST COVER
5.1.12	9132	GROUNDING BOLT
5.1.13	9229	USB
5.1.14	503108	USB DUST COVER
5.1.15	6032	L5-20R RECEPTACLE
5.1.16	6845	DUST COVER
5.1.17	9138	PANEL BODY

NO.	PART#	DESCRIPTION
5.1.18	34226-001	CO WARNING LIGHT
5.1.19	34226-001	CO FAULT LIGHT
5.2	91825	CROSS GROOVED DISC HEAD SCREW M5
5.3	500744	KNOB
5.4	92032	SCREW M4
5.5	500575	PLUG
6		INVERTER BRANCKET ASSEMBLY
6.1	500756	LEFT INVERTER BRACKET
6.2	500757	RIGHT INVERTER BRACKET
6.3	94003	TOOTH WASHER
6.4	500760	INVETER MODULE
6.5	500026	GROUNDING WIRE
6.6	91325	BOLT M6
6.7	92078	SCREW M6
6.8	504427	DC VOLTAGE REGULATOR
6.9	599071	CO FLAMEOUT ACTUATOR
7		BASEBOARD ASSEMBLY
7.1	91325	BOLT M6
7.2	500742	ISOLATION PAD
7.3	500736	BOTTOM PLATE
7.4	500752	AXLE
7.5	500651	WHEEL
7.6	90035	NUT M6
7.7	90027	SQUARE NUT M6
7.8	500060	LOCK CLIP
7.9	91330	BOLT M6
7.10		PULL ROD ASSEMBLY
7.10.1	500634	PULL ROD
7.10.2	500635	PULL ROD REAR SEAT
7.10.3	91330	BOLT M6
7.10.4	91325	BOLT M6
8		CONNECTING PLATE ASSEMBLY
8.1	91325	BOLT M6
8.2	500748	ISOLATION SUPPORT
8.3	500751	OIL DRAIN RUBBER SLEEVE
8.4	500754	RIGHT CONNECTING PLATE
8.5	500755	LEFT CONNECTING PLATE
8.6	91334	BOLT M6
9		CARBON CANNISTER ASSEMBLY
9.1	95146	FUEL TANK AND CARBON CANISTER CONNECTION PIPE
9.2	95019	CARBON CANISTER AND AIR FILTER CONNECTING PIPE
9.3	500758	CARBON CANISTER BRACKET
9.4	263801L	CARBON CANISTER ASSEMBLY
9.5	94423	FUEL LINE CLAMP

EXPLODED VIEW

EXPLODED VIEW A CONTINUED

NO.	PART#	DESCRIPTION
9.6	94403	FUEL LINE CLAMP
9.7	91325	BOLT M6
10		LEFT FRAME ASSEMBLY
10.1	500732-126	LEFT FRAME
10.2	92003	SCREW M6
10.3	500060	LOCK CLIP
11		LEFT PANEL ASSEMBLY
11.1	500731-221	LEFT PANEL
11.2	92117	CROSS GROOVED DISC HEAD DETACHABLE SCREW M6
12		OIL MAINTENANCE COVER ASSEMBLY
12.1	500740-221	OIL MAINTENANCE COVER
12.2	94265	FLAT WASHER
12.3	500510-116	OIL CAP KNOB
12.4	94094	SPLIT WASHER
13	500739-126	OBSERVATION COVER
14		FUEL TANK ASSEMBLY
14.1	500737	FUEL TANK MOUTH COVER
14.2	500741L	FUEL TANK
14.3	500745	OVERFLOW TUBE
14.4	94412	FUEL LINE CLAMP
14.5	500749	FILTER ELEMENT
14.6	500852L	FUEL TANK AND OIL SWITCH CONNECTIN PIPE
14.7	500509	FUEL SLOT
14.8	500009	FUEL TANK ISOLATION RUBBER PAD C
14.9	94423	FUEL LINE CLAMP
14.10	500542	SEALING RING
14.11	92078	SCREW M6
14.12	500699	FUEL CAP
15		ASSEMBLY HANDLE
15.1	500738-221	HANDLE
15.2	92078	SCREW M6
16		MUFFLER PANEL ASSEMBLY
16.1	500998	MUFFLER PANEL
16.2	500750	EXHAUST SEALANT
16.3	92078	SCREW M6
17		RIGHT FRAME ASSEMBLY
17.1	500733-126	RIGHT FRAME
17.2	92003	SCREW M6
17.3	504188	LOCK CLIP
17.4	500060	LOCK CLIP
17.5	92078	SCREW M6
17.6	500851	HANDLE DECORATIVE BOARD
17.7	500527	PULL ROPE GUIDE PLATE
17.8	94217	FLAT WASHER

NO.	PART#	DESCRIPTION
17.9	500661	BLIND RIVET
18		RIGHT PANEL ASSEMBLY
18.1	500730-221	RIGHT PANEL
18.2	92117	CROSS GROOVED DISC HEAD DETACHABLE SCREW M6
19	504510	CO CONTROL WIRING HARNESS
20	99012	SPARK PLUG WRENCH
21	500942	FUNNEL
22	99506	DUAL - PURPOSE SCREWDRIVER
23	504116	CONNECTOR
24	504114	PARALLEL CABLE
25	99665	OIL BOTTLE

EXPLODED VIEW

EXPLODED VIEW B

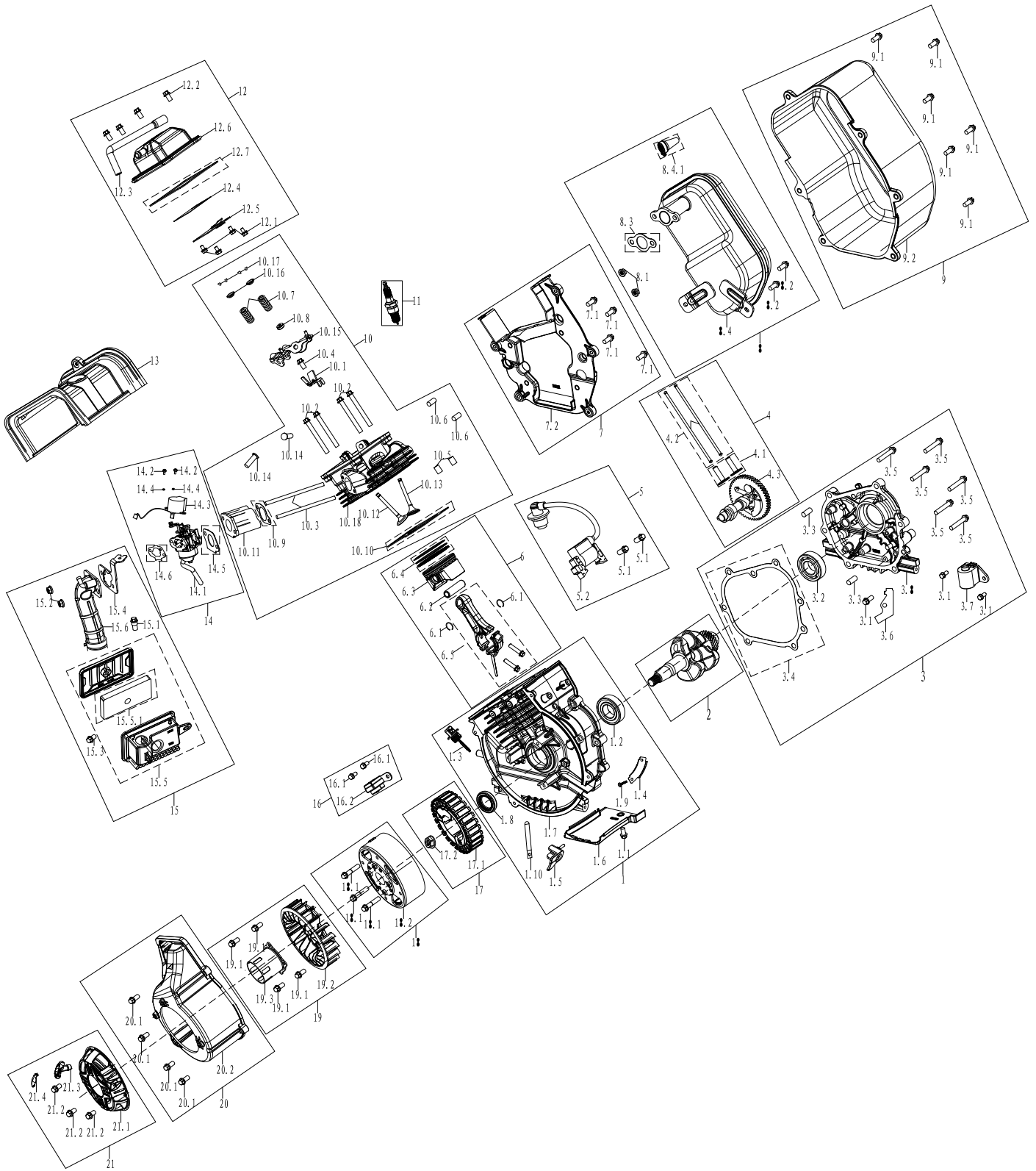

EXPLODED VIEW

EXPLODED VIEW B

NO.	PART#	DESCRIPTION
1		CRANKCASE ASSEMBLY
1.1	91325	BOLT M6
1.2	93009	BEARING
1.3	415601-160	DIPSTICK
1.4	239910	STATOR WIRE HARNESS CRIMPING PLATE
1.5	239907	OUTLET WINDSHIELD
1.6	230503	LOWER WIND-LEAD-COVER
1.7	230203	CRANKCASE
1.8	93508	CRANKCASE OIL SEAL
1.9	91882	BOLT M5
1.10	599601	METAL CLIP
2	230303	CRANKSHAFT
3		CRANKCASE COVER ASSEMBLY
3.1	91325	BOLT M6
3.2	93009	BEARING
3.3	240901	CRANKCASE LOCATING PIN
3.4	96242	CRANKCASE GASKET
3.5	91348	BOLT M8
3.6	209903	CRIMPING BLOCK
3.7	205101	OIL SENSOR
3.8	230103	CRANKCASE COVER
4	50150014	CAMSHAFT ASSEMBLY
4.1	296101	VALVE LIFTER
4.2	231902	PUSH ROD
4.3	232002	CAMSHAFT ASSEMBLY
5		IGNITION COIL ASSEMBLY
5.1	91329	BOLT M6
5.2	239909	IGNITION COIL
6		PISTON & PISTON RING ASSEMBLY
6.1	291301	PISTON PIN RING
6.2	315501	PISTON PIN
6.3	231202	PISTON
6.4	231602	PISTON RING ASSEMBLY
6.5	231502	CONNECTING ROD ASSEMBLY
7		REAR WIND-LEAD-COVER ASSEMBLY
7.1	91329	BOLT M6
7.2	230504	REAR WIND-LEAD-COVER
8		EXHAUST MUFFLER ASSEMBLY
8.1	90011	NUT M8
8.2	91325	BOLT M6
8.3	96246	EXHAUST GASKET
8.4	233702	MUFFLER
8.4.1	6789	SPARK ARRESTER
9		MUFFLER WIND DEFLECTOR ASSEMBLY
9.1	91330	BOLT M6
9.2	230505	MUFFLER WIND DEFLECTOR

NO.	PART#	DESCRIPTION
10		CYLINDER HEAD ASSEMBLY
10.1	232201	ROCKING RETAINER PLATE
10.2	91359	BOLT M8
10.3	91069	BOLT M6
10.4	91325	BOLT M6
10.5	240905	CYLINDER HEAD LOCATING PIN
10.6	91054	BOLT M8
10.7	236001	VALVE SPRING
10.8	241806	VALVE SEAL
10.9	96243	INTAKE GASKET
10.10	96253	CYLINDER HEAD GASKET
10.11	232302	CARBURETOR CONNECTION BLOCK
10.12	241712	INTAKE VALVE
10.13	245913	EXHAUST VALVE
10.14	232103	ROCKING ARM SHAFT
10.15	232102	ROCKING ARM
10.16	231803	VALVE SPRING RETAINER
10.17	230801	VALVE LOCK CLIP
10.18	231002	CYLINDER HEAD
11	97109	SPARK PLUG
12		CYLINDER HEAD COVER ASSEMBLY
12.1	91325	BOLT M6
12.2	91331	BOLT M6
12.3	95653	BREATHER TUBE
12.4	231103	BREATHER BOARD GASKET
12.5	231102	CYLINDER HEAD BREATHING PLATE
12.6	231101	CYLINDER HEAD COVER
12.7	96245	CYLINDER HEAD COVER GASKET
13	230502	UPPER WIND-LEAD-COVER
14		CARBURETOR ASSEMBLY
14.1	232802	CARBURETOR ASSEMBLY
14.2	92217	SCREW M4
14.3	752007	STEPPER MOTOR
14.4	94217	FLAT WASHER
14.5	96244	CARBURETOR GASKET
14.6	94226	STEEL WASHER
15		AIR FILTER ASSEMBLY
15.1	92170	BOLT M6
15.2	90035	NUT M6
15.3	91325	BOLT M6
15.4	239905	ELBOW BRACKET
15.5	232901	AIR FILTER ASSEMBLY
15.5.1	2034	AIR FILTER
15.6	95945	INTAKE PIPE
16		TRIGGER ASSEMBLY
16.1	91325	BOLT M6
16.2	339916	TRIGGER

EXPLODED VIEW

EXPLODED VIEW B CONTINUED

NO.	PART#	DESCRIPTION
17		STATOR ASSEMBLY
17.1	239902	STATOR
17.2	90003	NUT M14
18		ROTOR ASSEMBLY
18.1	91338	BOLT M6
18.2	239903	ROTOR
19		IMPELLER ASSEMBLY
19.1	91330	BOLT M6
19.2	234602	IMPELLER
19.3	234501	STARTER PULLEY
20		BLOWER HOUSING ASSEMBLY
20.1	91331	BOLT M6
20.2	2072	BLOWER HOUSING
21		START PULLER ASSEMBLY
21.1	334726	RECOIL COVER
21.2	91340	BOLT M6
21.3	500018	RECOIL HANDLE
21.4	500017- 231	RECOIL HANDLE COVER

SCHEMATICS

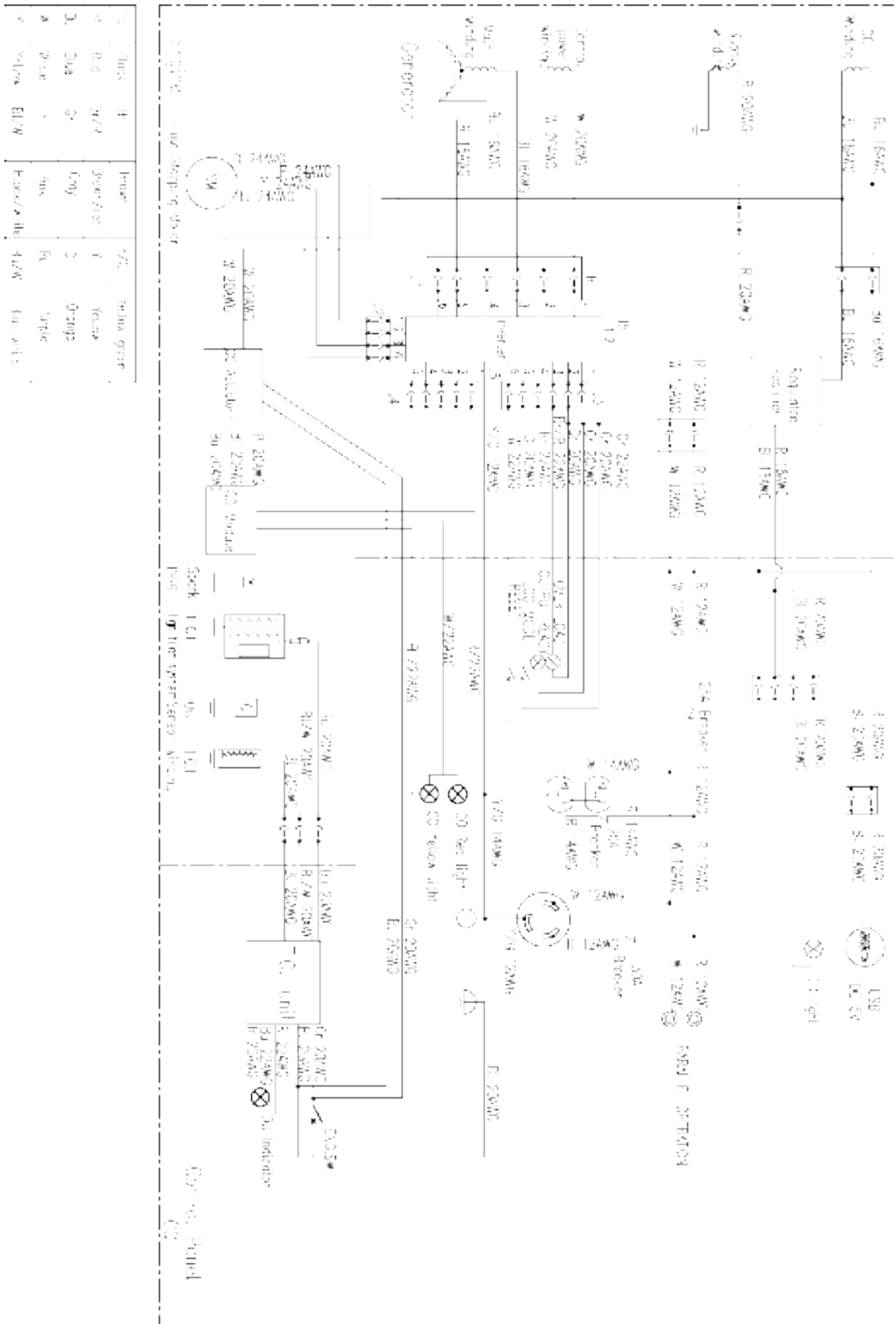

1	Blue	H	Power	275	Yellow green
2	R/D	W/Y	Operator	1	Yellow
3	Blue	0	Emergency	2	Orange
4	Green	1	Stop	3	Purple
5	Yellow	Blue/W	Reset/Interlock	4	Blue