

# PlantPAX Logix Batch and Sequence Manager

Version 4.0



## Important User Information

Read this document and the documents listed in the additional resources section about installation, configuration, and operation of this equipment before you install, configure, operate, or maintain this product. Users are required to familiarize themselves with installation and wiring instructions in addition to requirements of all applicable codes, laws, and standards.

Activities including installation, adjustments, putting into service, use, assembly, disassembly, and maintenance are required to be carried out by suitably trained personnel in accordance with applicable code of practice.

If this equipment is used in a manner not specified by the manufacturer, the protection provided by the equipment may be impaired.

In no event will Rockwell Automation, Inc. be responsible or liable for indirect or consequential damages resulting from the use or application of this equipment.

The examples and diagrams in this manual are included solely for illustrative purposes. Because of the many variables and requirements associated with any particular installation, Rockwell Automation, Inc. cannot assume responsibility or liability for actual use based on the examples and diagrams.

No patent liability is assumed by Rockwell Automation, Inc. with respect to use of information, circuits, equipment, or software described in this manual.

Reproduction of the contents of this manual, in whole or in part, without written permission of Rockwell Automation, Inc., is prohibited.

Throughout this manual, when necessary, we use notes to make you aware of safety considerations.



**WARNING:** Identifies information about practices or circumstances that can cause an explosion in a hazardous environment, which may lead to personal injury or death, property damage, or economic loss.



**ATTENTION:** Identifies information about practices or circumstances that can lead to personal injury or death, property damage, or economic loss. Attentions help you identify a hazard, avoid a hazard, and recognize the consequence.

---

### IMPORTANT

Identifies information that is critical for successful application and understanding of the product.

---

Labels may also be on or inside the equipment to provide specific precautions.



**SHOCK HAZARD:** Labels may be on or inside the equipment, for example, a drive or motor, to alert people that dangerous voltage may be present.



**BURN HAZARD:** Labels may be on or inside the equipment, for example, a drive or motor, to alert people that surfaces may reach dangerous temperatures.



**ARC FLASH HAZARD:** Labels may be on or inside the equipment, for example, a motor control center, to alert people to potential Arc Flash. Arc Flash will cause severe injury or death. Wear proper Personal Protective Equipment (PPE). Follow ALL Regulatory requirements for safe work practices and for Personal Protective Equipment (PPE).

---

	<b>Preface</b>	
	Software Compatibility and Content Revision.....	5
	Before You Begin.....	6
	Extract the LBSM Zip Files.....	7
	Install the Infrastructure .....	7
	LBSM Faceplates.....	8
	Quick Display.....	9
	Operator Tab .....	10
	Manual Tab.....	11
	Advanced (Engineering) Tab .....	12
	Additional Resources.....	13
	Guidelines.....	16
	Functional Description .....	16
	Install the Components.....	17
	Configure Controller Files .....	17
	Incorporate LBSM into an HMI Application .....	20
	Configure LBSM (size arrays) .....	30
	Modify the Data Structure .....	30
	Unit Configuration .....	35
	User-defined Data Types.....	36
	Operator Prompt.....	36
	Phase Configuration.....	37
	Configure a Master Recipe.....	40
	Setting Phase Parameters.....	44
	Using Pause and Skip .....	45
	Built-in Phases .....	46
	Create a Batch .....	51
	Save Master Recipe.....	53
	Connect Equipment to Controller Logic.....	55
	PhaseManager Interface.....	56
	Bit Interface.....	58
	Use the DN and State Bits.....	60
	Operator Phase Control .....	62
	Equipment Control .....	65
	Multi-Step Configuration .....	65
	Easy Recipe Configuration .....	68
	Start/Run Batch Demonstration .....	69
	LBSM Help Displays .....	86
	<b>Appendix A</b>	
	PIContinue.....	87
	PIOwned .....	88
	PIImmRel (immediate release).....	88
	Manual Generation of Batch ID .....	88
<b>Logix Batch and Sequence Manager (LBSM)</b>		
<b>Advanced Capabilities</b>		

<b>Equipment Interface Codes</b>	<b>Appendix B</b> Equipment Interface Codes ..... 89
<b>Bit Interface Examples</b>	<b>Appendix C</b> 'Add Ingredient' Example ..... 91 Run Until Done Example ..... 92 Run Until Stopped Example..... 94 Run Until Done, Continue Until Stopped Example ..... 96
<b>LBSM Reporting</b>	<b>Appendix D</b> LBSM Report Data Structure ..... 99 Retrieve Records ..... 99 Boolean Mechanism ..... 100 Integer Mechanism ..... 100 Log on Demand ..... 100
<b>HMI Security Codes</b>	<b>Appendix E</b> HMI Security Codes..... 101

This document applies to version 4.0 of the PlantPAx® Logix Batch and SequenceManager™ (LBSM). The LBSM application defines and stores recipes and sequences equipment and phases to make products.

## Software Compatibility and Content Revision

Topic	Page
Master Control Recipe Edits - Changed HMI and Table	<a href="#">36</a>
Prompt section rewritten, New HMI	<a href="#">36</a>
Incorporate LBSM into an HMI Application- Split step 11 into two steps	<a href="#">29</a>
Modify Data Structure - Added steps to expand User-Defined folder	<a href="#">31</a> , <a href="#">32</a> , <a href="#">33</a> , <a href="#">34</a>
Pause and Skip section was rewritten, new HMI	<a href="#">45</a>
Wait Timer section rewritten, New HMI	<a href="#">50</a>
Security information rewritten	<a href="#">101</a>

The LBSM application can be downloaded from the Product Compatibility and Download Center at <http://www.rockwellautomation.com/rockwellautomation/support/downloads.page>.

The LBSM application version 4.0 is compatible with the following products:

- Logix 5000™ controller<sup>(1)</sup>, firmware revision 18 or later
- RSLogix 5000® software, version 18 or later
- Studio 5000 Logix Designer® application, version 24.x
- FactoryTalk® View Site Edition (SE) and FactoryTalk View Machine Edition (ME) software, version 7.0 or later

(1) The CompactLogix™ 5370 L1 controller does not meet minimum CPU and memory requirements for the LBSM application. Verify your sizing requirements with the LBSM Memory Estimator that is included with the LBSM download. See [Figure 2 on page 7](#).

## Before You Begin

Familiarity with ISA-88 is helpful because LBSM uses constructs and terminology that is established in that standard. While the LBSM application can be used in non-batch equipment sequencing, we have chosen to use batch sequencing examples and ISA-88 terminology throughout this manual.

[Figure 1](#) is the state model for LBSM procedure management.

**Figure 1 - LBSM State Model**

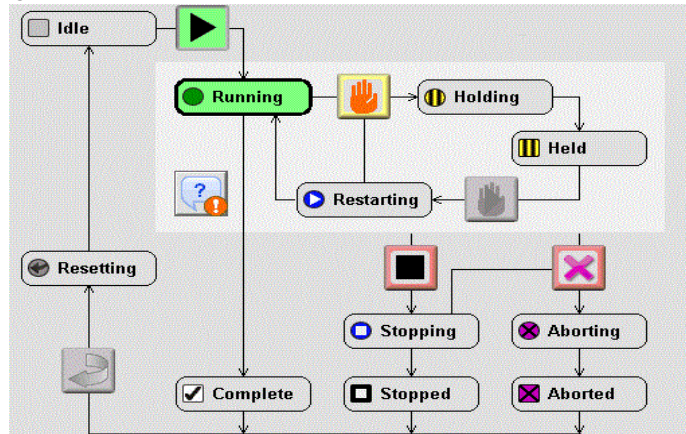

To implement an LBSM solution, we also suggest knowledge of the following:

- How to program Logix 5000 controllers with the Studio 5000 Logix Designer application
- How to use the Rockwell Automation® Library of Process Objects

## Extract the LBSM Zip Files

The LBSM\_Vxx.yy.zz zip file that is downloaded with your LBSM application includes two folders:

- Documents -- Contains the LBSM Memory Estimator (a Microsoft Excel spreadsheet) to verify your sizing requirements for the controller  
See [Figure 2](#).
- Files -- Includes controller code, graphics, sample project, and templates

Figure 2 - Sample LBSM Memory Calculator

1	<b>Instructions:</b>													
2	Enter the 10 "LBSM Memory Variables" in the spreadsheet (cells B16-B25)													
3														
4	<b>Disclaimer:</b>													
5	The LBSM memory estimator is provided for preliminary memory estimation purposes only.													
6	Due to varying conditions, please confirm all results with actual hardware during system design.													
7														
8	<b>Notes:</b>													
9	If any 'LBSM Memory Variables' entered are out of range the cell will turn RED													
10	Multiple memory calculations are shown. These represent total controller memory as well as each controller tag.													
11	Since controller tags are limited to 2mb size, invalid configurations will be shown with a RED highlight.													
12														
13														
14														
15														
16	<b>LBSM Memory Variables</b>					<b>Constraints</b>								
17	Number of Units (#UN)	1			Where	1 <= #UN <= 32								
18	Number of Master Sequences per Unit (#MS)	4			Where	1 <= #MS <= 32								
19	Number of Equipment per Unit (#EQ)	10			Where	1 <= #EQ <= 32								
20	Number of Steps in a Recipe (#ST)	20			Where	1 <= #ST <= 32								
21	Number of Prompt Configs available for a Unit	4			Where	1 <= #PR <= 32								
22	Number of Equipment Using Phase Manager	0	10		Where	0 <= #PM <= Total Number of Equipment in the Project								
23	Application includes Journal Capability	0			Where	0 = No, 1 = Yes								
24	Number of Journal Records Allocated	0			Where	0 <= #JR <= User Defined up to limit of memory								
25	Average memory consumed per Equipment (ME)	0	KB		Where	ME is memory consumed by user Phase/Equipment code (average per piece of equipment)								
26	Additional memory overhead per controller (MO)	0	KB		Where	MO is memory consumed by user Overhead code per controller								
27														
28	<b>LBSM Memory Calculations</b>					<b>LBSM Memory Equations</b>								
29	Total Controller Memory =	577.84	KB											
30	Total Unit Data Memory	102.84	KB											
31	Total Code, UDT and AOI Definition Memory	375	KB											
32	HMI Buffer Memory	100	KB											
33	Journal Infrastructure and Data Memory	0	KB											
34														
35														

LBSM Memory Constants			
EQPI	1.72	KB	Memory for Equipment
SQm	24	KB	Memory for 1 master sequence
SQrt	27	KB	Memory for 1 runtime sequence
Step	0.7	KB	Memory for 1 Step
PromptCfg	0.65	KB	Memory for 1 Prompt Config
Phase Manag	1	KB	Memory for 1 EQ with PM
Core USA De	70	KB	UDT, Structures, AOI Definitions
Journal USA	27	KB	UDT, Structures, AOI Defs Journal
SQPI	305	KB	Memory for SQ & PI code
Journal Code	75	KB	Memory for Journal code
Journal Reco	0.18	KB	Memory for 1 Journal Record
HMI	100	KB	Memory used by HMI

## Install the Infrastructure

The LBSM application file is designed as a standalone starting point for projects. The add-on capability lets you integrate the application into your existing controller project. To integrate the LBSM application into your application, see the following sections:

- Controller infrastructure – See [page 17](#)
- HMI infrastructure – See [page 20](#)

## LBSM Faceplates

The LBSM faceplate consists of three tabs: Operator, Manual, and Advanced (Engineering.)

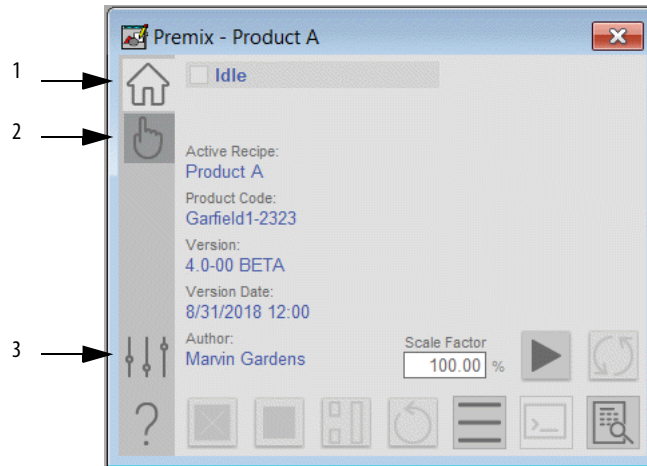

**Figure 3 - LBSM Faceplate Tabs**

Item	Description
1	Operator Tab
2	Manual Tab
3	Advanced Tab (Engineering)

The main display can be configured to open with the Quick Display or the Operator tab depending on the parameter value that is entered in the Global Objects Parameters Values table. See [Figure 8 on page 29](#).

The faceplate provides the means for operators, maintenance personnel, engineers, and others to interact with the LBSM instruction instance. When a given input is restricted via FactoryTalk View security, the required user security code letter is shown in the table.

For a list of the security codes and descriptions, see [HMI Security Codes on page 101](#).



## Quick Display

The Quick Display screen provides means for operators to perform key interactions with the LBSM application. From the Quick Display, you can navigate to the faceplate for full access for operation, maintenance, and configuration. Press the Home button to navigate to the full faceplate.

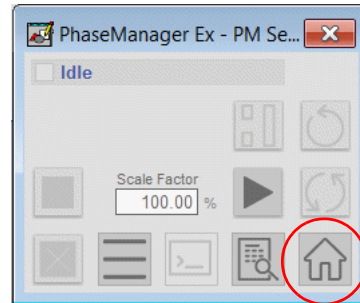

## Operator Tab

The control buttons on the LBSM application let you run a batch from this tab. In addition, the Operator tab shows the following information:

- Current state
- What phase the sequence is waiting on and how much time remains
- Manual prompt attention

Current step and wait timer in sequence, if applicable

**Figure 4 - Operator Tab Description**

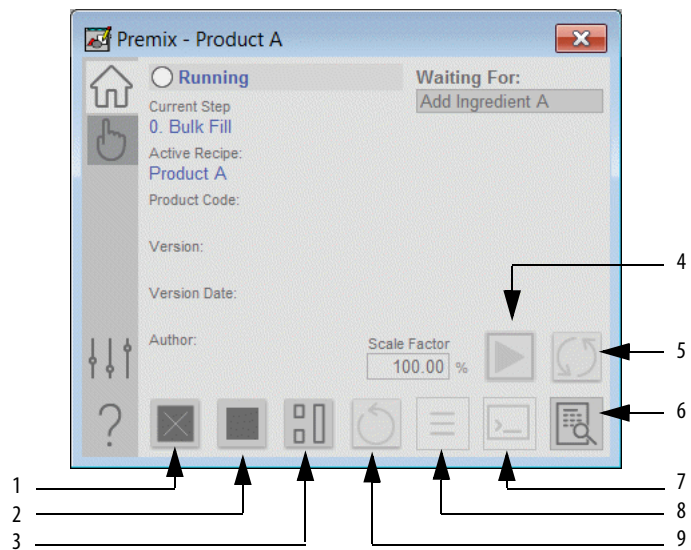
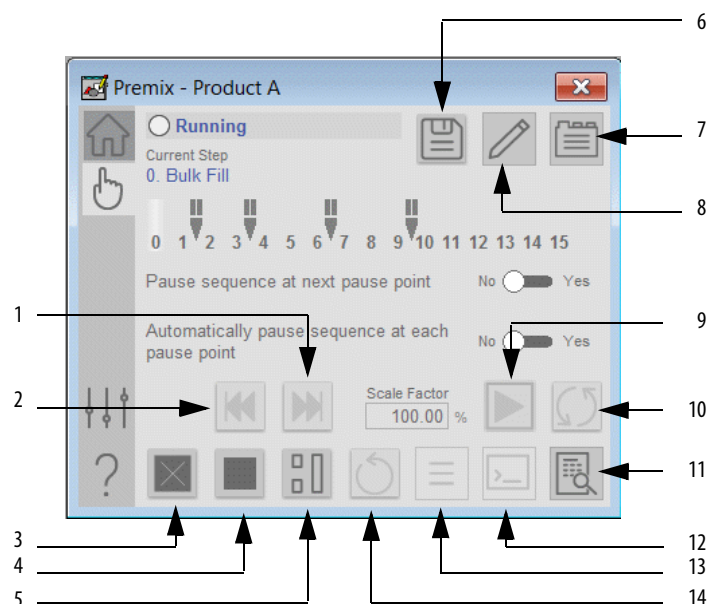

**Figure 5 - Operator Tab Description**

Item	Description
1	Abort sequence
2	Stop sequence
3	Hold sequence
4	Start or resume sequence
5	Reset sequence
6	Access the runtime detail faceplate
7	Respond to Operator prompt
8	Load a sequence from the master sequence list
9	Restart sequence

## Manual Tab

This tab provides manual controls over the features.



**Figure 6 - Manual Tab Description**

Item	Description
1	Skip to next pause point
2	Skip to previous pause point
3	Abort sequence
4	Stop sequence
5	Hold sequence
6	<b>Save As</b> – Saves the current recipe as a master recipe. A warning message states ‘Are you sure you want to overwrite Master Recipe (name) with the current runtime Recipe?’ Click Yes or No.
7	<b>Master Sequence Edit</b> – Accesses the Edit Master Sequence window to let you select a master recipe from a list. Edits that are made to the master recipe apply to any new batches.
8	<b>Control Recipe Edit</b> – Accesses a configuration dialog screen to let you change the currently loaded recipe in the unit. These edits are only for this batch; does not affect the master recipe.
9	Start or resume sequence
10	Reset sequence
11	Show runtime detail
12	Acknowledge operator prompt
13	Load a sequence from the master sequence list
14	Restart a sequence

## Advanced (Engineering) Tab

From the Engineering tab you can:

- Set the Unit Name and Number
- Set the Security Area
- Set the allowable Scale Range
- Access the Phase Configuration display to configure the equipment

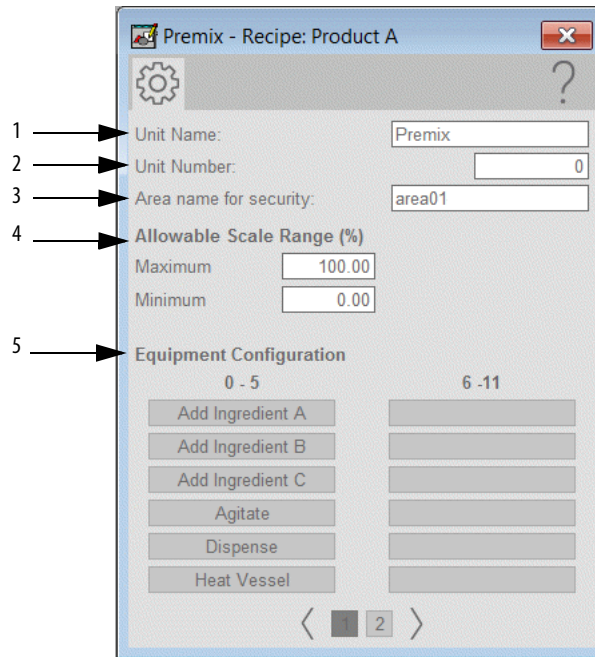

**Figure 7 - Advanced (Engineering) Tab Description**

Item	Description
1	Type a name for the unit.
2	Type a unit number. <b>IMPORTANT:</b> This number is the unit number that is used to identify the equipment in your facility, not the unit index used in the controller array.
3	Type in the area name for security. The default is 'area01'.
4	The allowable scale range limits the 'Scale' input that affects 'Scaled' configuration in equipment. Click the Minimum and Maximum boxes to access a calculator for entering the values for the scale range.
5	Click an equipment configuration button to access the Phase Configuration Display. See <a href="#">Phase Configuration on page 37</a>

## Additional Resources

These documents contain additional information concerning related products from Rockwell Automation.

Resource	Description
FactoryTalk View SE Edition User Manual, publication <a href="#">VIEWSE-UM006</a>	Explains how to use this software package for HMI applications that can involve multiple users and servers, which are distributed over a network.
FactoryTalk View Machine Edition User's Guide, publication <a href="#">VIEWME-UM004</a>	Explains how to use this software package for HMI applications that monitor and control automated processes and machines.
PhaseManager™ User Manual, publication <a href="#">LOGIX-UM001</a>	Explains how to define a state model for your equipment and develop equipment phases.
Logix 5000 Controllers General Instructions Reference Manual, publication <a href="#">1756-RM003</a>	Provides programming controller applications by using relay ladder instructions.
PlantPAx Logix Batch and Sequence Manager Product Profile, publication <a href="#">PROCES-PP004</a>	Explains a controller-based batch and sequencing solution that leverages the Logix Control Platform and FactoryTalk View software for integrated control and visualization.
Rockwell Automation® Library of Process Objects, publication <a href="#">PROCES-RM002</a>	Provides an overview of the code objects, display elements, and faceplates that comprise the Rockwell Automation Library of Process Objects.
Rockwell Automation Library of Process Objects Reference Manuals: publication <a href="#">PROCES-RM013</a> publication <a href="#">PROCES-RM014</a>	Provides an overview of the code objects, display elements, and faceplates that comprise the Rockwell Automation Library of Process Objects.
PlantPAx Distributed Control System Selection Guide, publication <a href="#">PROCES-SG001</a>	Provides basic definitions of system elements and sizing guidelines for procuring a PlantPAx system.
PlantPAx Distributed Control System Reference Manual, publication <a href="#">PROCES-RM001</a>	Provides characterized recommendations for implementing your PlantPAx system.
Product Compatibility and Download Center at <a href="http://www.rockwellautomation.com/rockwellautomation/support/pcdc.page">http://www.rockwellautomation.com/rockwellautomation/support/pcdc.page</a>	Website helps you find product-related downloads including firmware, release notes, associated software, drivers, tools, and utilities.

You can view or download publications at <http://www.rockwellautomation.com/literature/>.

**Notes:**

# Logix Batch and Sequence Manager (LBSM)

The PlantPax® Logix Batch and SequenceManager™ (LBSM) application provides batch-process management functionality. A Logix controller and FactoryTalk® View software are the only requirements for configuration and execution. This solution lets you start small with a finite number of recipes, but easily scales into a server-based system without costly re-engineering and testing.

The ability of the LBSM application to sequence phases or equipment with or without Logix PhaseManager™ software provides a platform that you can use in nearly any application. Logix PhaseManager software permits seamless migration from LBSM to FactoryTalk Batch software.

The global object and faceplate that are shown are examples of the graphical interface tools for this standalone application.

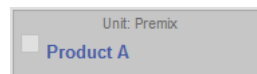
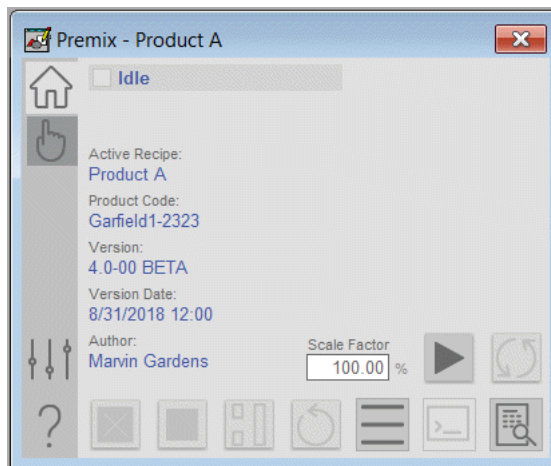

## Guidelines

The LBSM application has the following features:

- Up to 32 Master Recipes per unit; default is 6 Master Recipes per unit
- Up to 32 phases per unit; default is 16 phases per unit
- A maximum of 32 steps per procedure
- Memory calculator (shown on [page 7](#)) helps you select a Logix controller to handle operational requirements

## Functional Description

The LBSM application configures and stores recipes while defining how to make products. A recipe consists of a procedure and formula. The procedure defines the process action and the formula contains the parameters that modify the activity. Examples of process actions are add, agitate, and so on. Activities include how much to add, for how long, how fast to agitate, and so on.

A unit is a group of equipment that works together to perform a major processing activity, such as a combination of ingredients. For example, an LBSM unit can be a mixer, blender, reactor, process skid, or continuous process equipment. LBSM is configured by default for one unit, but can be modified to accommodate additional independent units per controller.

An equipment phase commands the equipment in a unit to perform a specific process action. For example, add ingredient A, add ingredient B, and dispense can be equipment phases for a mixing tank. The LBSM application is preconfigured to include up to 16 equipment phases per unit. If necessary, a controller tag (`_Equipment`) can be modified to accommodate additional equipment phases.

---

**IMPORTANT** Expanding the number of equipment phases applies to all units in the system. You cannot expand the number of equipment phases on a per unit basis.

---



## Install the Components

To begin the process, download the LBSM zip files from the Product Compatibility and Download Center at <http://www.rockwellautomation.com/rockwellautomation/support/downloads.page>.

You must install one of two LBSM applications that are included in the download file set:

- Components with Journal
- Components No Journal (smaller footprint without reporting)

See [page 7](#) for a description of the zip folder contents.

## Configure Controller Files

This section describes how to install the controller files. You have two options:

- Integrate the LBSM application into your existing application
- Start a new project with the templates provided in the download
  - LBSM\_Template\_No\_Journal.ACD
  - LBSM\_Template\_with\_Journal.ACD

---

**IMPORTANT** ControlLogix® and CompactLogix™ controllers<sup>(1)</sup> are available for the LBSM application. We suggest that you use the spreadsheet that is included in the download to calculate memory requirements for your system. The requirements determine if your selected controller has sufficient capacity.

---

(1) The CompactLogix™ 5370 L1 controller does not meet minimum CPU and memory requirements for the LBSM application.

Complete these steps **only** for integrating the LBSM application into an **existing** Studio 5000 Logix Designer® project. The supplied templates for a new project contain the necessary tasks.

1. To add the tasks, \_PIs and \_SQs, along with the program within the tasks, right-click the Tasks folder in the Controller Organizer and choose New Task.

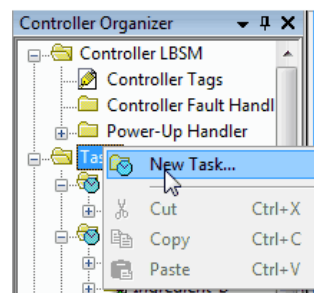

- The \_PIs (procedural interfaces) task controls the execution of each phase.
- The \_SQs (sequences) task controls the execution of each sequence.

- The codes within the routines are locked from the user.
2. On the New Task dialog box, create a task that is named `_PIs` and set the configuration to the following:
    - Type: Periodic
    - Period: 20...100 ms (typical)
    - Priority: Low number (lower number yields higher priority)
    - Watchdog: 500 ms (default)

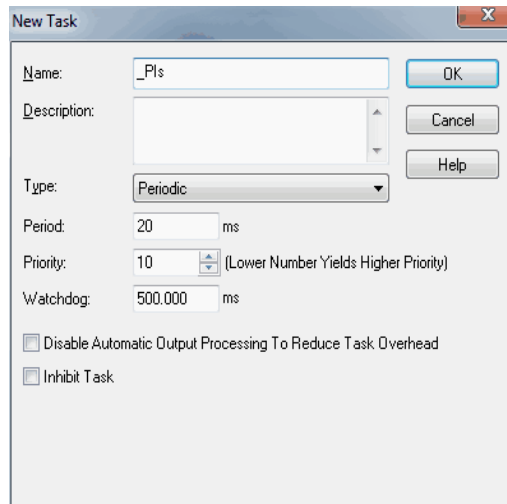

3. Right-click `_PIs` and choose Import Program.

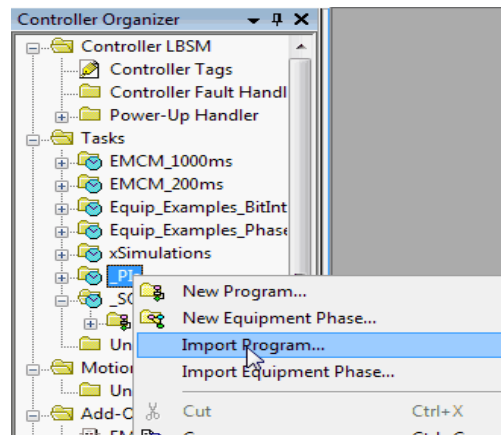

4. Browse for the `PI.L5X` file and click Import.  
The Import Configuration dialog box appears.
5. Click OK.
6. Repeat [step 1](#) through [step 5](#) for the `_SQs` task, by using a period of 50...100 ms and the `SQ.L5X` program file.

7. To add the EM\_LBSM Add-On Instruction to your project, right-click the Add-On Instructions folder and choose Import Add-On Instruction.

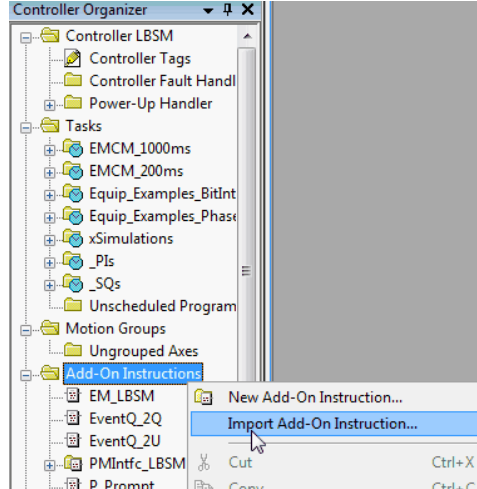

---

**IMPORTANT** You must use the EM\_LBSM Add-On Instruction in each equipment module that you create. This Add-On Instruction manages the equipment module modes and handshakes to the rest of the system.

---

The Import Add-On Instruction dialog box appears.

8. Select the EM\_LBSM.L5X Add-On Instruction and click Import.
9. On the Import Configuration dialog box, click OK.

The controller scope tags in the Controller Scope Tags table are added to your Logix project. By default, the following tags are available:

- One unit
- 16 equipment phases per unit
- Six master recipes per unit

To modify array sizes, if necessary, see [Table 5 on page 36](#).

## Incorporate LBSM into an HMI Application

You must import the visualization files that are associated with and included in the LBSM download. The files are included in the download from the Product Compatibility and Download Center at

<http://www.rockwellautomation.com/rockwellautomation/support/pcdc.page>.

---

**IMPORTANT** The visualization file dependencies require Process Library content imports to occur in a specific order as reflected in the following tables:

- Images
  - Global Objects
  - Standard Displays
  - HMI Tags
- 

Images are external graphic files that can be used in displays. They must be imported for FactoryTalk View to use them.

Upon import, PNG files are renamed by FactoryTalk View with a .bmp file extension, but retain a .png format.

**Table 1 - Visualization Files: Images (.png)**

FactoryTalk View SE Software	FactoryTalk View ME Software	Description
All .png files in the images folder	All .png files in the images folder	These are the common icons that are used in the global objects and standard displays for all Process Objects. See <a href="#">Import Images on page 22</a> for procedures.

The Global Object files (.ggfx file type) in the following table are Process Library display elements that are created once and referenced multiple times on multiple displays in an application. When changes are made to a Global Object, all instances in the application are automatically updated.

**Table 2 - Visualization Files: Global Objects (.ggfx)**

FactoryTalk View SE Software	FactoryTalk View ME Software	Description
(RA-LBSM) Standard Objects	(RA-LBSM-ME) Standard Objects	Standard global used on Sequencer displays.
(RA-BAS) Common Faceplate Objects	(RA-BAS-ME) Common Faceplate Objects	Common global objects used on all process object faceplates.
(RA-BAS) Process Faceplate Common Objects	(RA-BAS-ME) Process Faceplate Common Objects	Faceplate Configuration, Navigation, Command, and Display Objects
(RA-UI) Prompt Objects	(RA-UI-ME) Prompt Objects	Global objects used for prompts. See <a href="#">Import Global Object Files on page 23</a> for procedures.

The Standard Display files (.gfx file type) in the following table are the Process Library displays that you see at runtime.

**Table 3 - Visualization Files: Standard Displays (.gfx)**

FactoryTalk View SE Software	FactoryTalk View ME Software	Description
(RA-LBSM) Equipment-Config	(RA-LBSM-ME) Equipment-Config	Configuration display used to configure the equipment phase.
(RA-LBSM) Equipment-Faceplate	(RA-LBSM-ME) Equipment-Faceplate	Faceplate used for the equipment module.
(RA-LBSM) MasterSeq-Edit-Select	(RA-LBSM-ME) MasterSeq-Edit-Select	Selection display used to select the Master Sequence to edit.
(RA-LBSM) MasterSeq-Load-Select	(RA-LBSM-ME) MasterSeq-Load-Select	Selection display used to select the Master Sequence to load into the runtime tags.
(RA-LBSM) Phase-Faceplate	(RA-LBSM-ME) Phase-Faceplate	Faceplate used to run the phases in a sequence.
(RA-LBSM) Sequence-Config	(RA-LBSM) Sequence-Config (RA-LBSM) Sequence-Config2 (RA-LBSM) Sequence-Config3	Configuration display used to configure the unit and phases in the sequence.
—	(RA-LBSM-ME) Sequence-Config-Step-Confirm	Confirmation display used to verify the requested 'Delete Step', 'Copy Step', and 'Insert Step' commands.
(RA-LBSM) Sequence-Config-Easy	—	Configuration display used to enable or disable phases for multiple steps in a sequence.
(RA-LBSM) Sequence-Config-Step	(RA-LBSM-ME) Sequence-Config-Step	Configuration display used to configure one step in a sequence.
(RA-LBSM) Sequence-Config-MultiStep	(RA-LBSM-ME) Sequence-Config-MultiStep	Configuration display used to configure attributes for multiple steps in a sequence.
(RA-LBSM) Sequence-Config-PhaseStep	(RA-LBSM-ME) Sequence-Config-PhaseStep	Configuration display used to configure the instance of a phase and step in a sequence.
(RA-LBSM) Sequence-Detail	(RA-LBSM-ME) Sequence-Detail	Faceplate used to show Run Time Detail of a sequence.
(RA-LBSM) Sequence-Faceplate	(RA-LBSM-ME) Sequence-Faceplate	The Sequence faceplate used for the object.
(RA-LBSM) Sequence-Help	(RA-LBSM-ME) Sequence-Help	Help information that is accessed from the sequence faceplate.
(RA-LBSM) Sequence-Quick	(RA-LBSM-ME) Sequence-Quick	The Quick display used for the object.
(RA-LBSM) Sequence-RunTime-PhaseValues	(RA-LBSM-ME) Sequence-RunTime-PhaseValues	Display used to show the phase values for one step in the runtime sequence.
(RA-LBSM) Sequence-RunTime-SaveAs-Confirm	(RA-LBSM-ME) Sequence-RunTime-SaveAs-Confirm	Confirmation display used to verify a master sequence overwrite during the requested 'Save As Master Sequence' command.
(RA-LBSM) Sequence-RunTime-SaveAs-Select	(RA-LBSM-ME) Sequence-RunTime-SaveAs-Select	Display used to select a Master Sequence location for the runtime sequence.
—	(RA-LBSM-ME) Sequence-RunTime-Confirm	Confirmation display used to verify the requested 'Sequence Stop' or 'Sequence Abort' command.
(RA-UI) P_Prompt-Config	(RA-UI-ME) P_Prompt-Config	Display used to configure the prompt.
(RA-UI) P_Prompt-Response	(RA-UI-ME) P_Prompt-Response	Display used to complete the operator prompt.
(RA-UI) P_Prompt-Select	(RA-UI-ME) P_Prompt-Select	Display used to select a prompt for the sequence step.

HMI Tags are created in a FactoryTalk View ME application to support tab switching on Process Library faceplates. The HMI tags can be imported via the comma-separated values file (.csv file type) in the following table.

**Table 4 - Visualization Files: HMI Tags (.csv)**

FactoryTalk View SE Software	FactoryTalk View ME Software	Description
FTViewSE_ProcessLibrary_Tags_4_0_xx.CSV	FTViewME_ProcessLibrary_Tags_4_0_xx.CSV	These tags must be imported into the FactoryTalk View SE/ME project to support the LBSM displays. See <a href="#">Add HMI Tags to the Application on page 26</a> for procedures.

### *Import Images*

Complete these steps to add the common icons (images) for the global objects and faceplates for the HMI application.

1. In the FactoryTalk View Studio software, expand the Graphics folder in the Explorer™ window.
2. Right-click Images and choose Add Component Into Application.

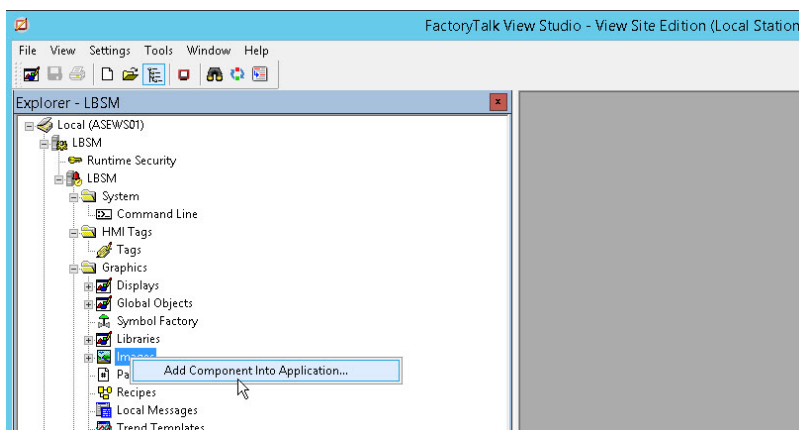

The Add Component Into Project dialog box appears.

3. Browse to your downloaded graphics folder.

#### 4. Open the graphics folder and double-click the Images folder.

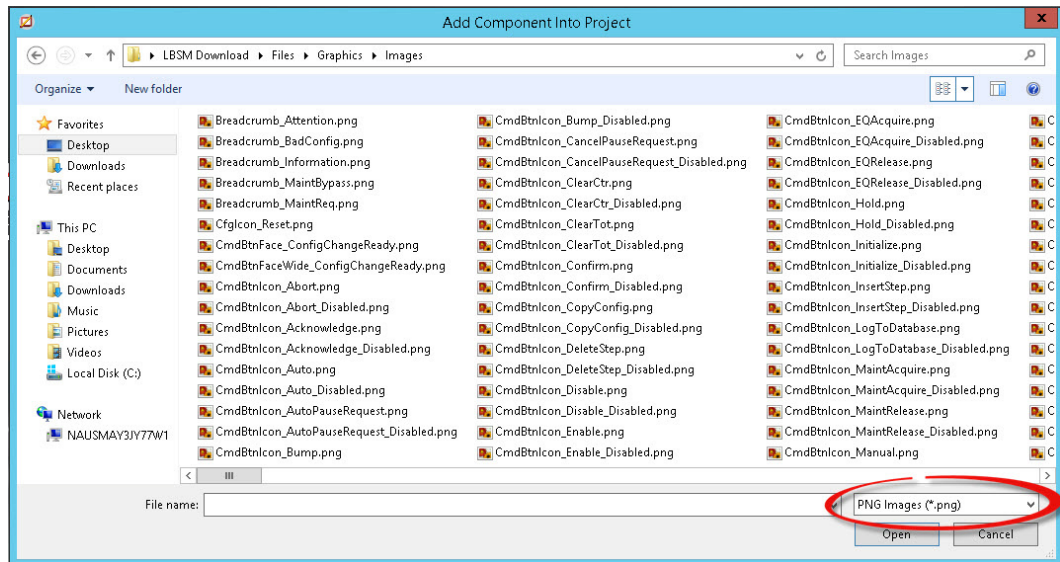

---

**IMPORTANT** Change the path to the image folder and the file type to PNG. PNG files provide more control with transparency.

---

#### 5. Click the pull-down menu (as circled) and select a file type.

For example, PNG Images (\*.png)

#### 6. Click Ctrl-A to highlight all .png images.

#### 7. Click Open to import the images.

### Import Global Object Files

Global objects serve two purposes:

- Faceplate objects files contain common elements that are used in building faceplate displays.
- Graphics Library files contain device symbols that you can use to build your application displays. Clicking the symbol opens the corresponding faceplate displays.

#### 1. In the FactoryTalk View Studio software, expand the Graphics folder in the Explorer window.

2. Right-click Global Objects and choose Add Component Into Application.

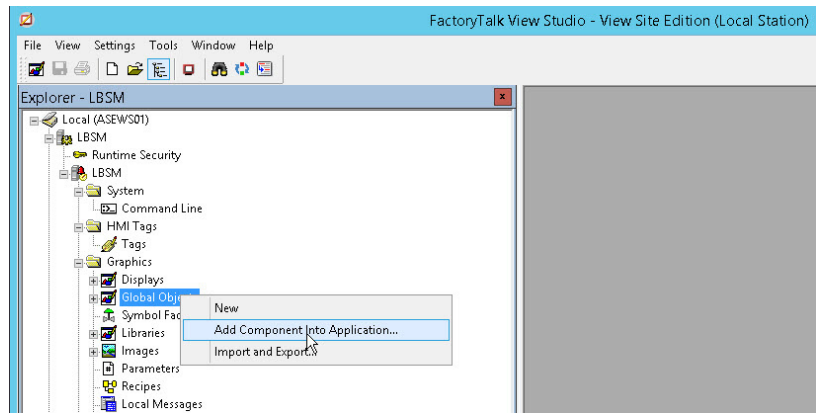

The Add Component Into Project dialog box appears.

3. Browse to your downloaded graphics folder.
4. Open the graphics folder and double-click the FTView SE folder.
5. Double-click Global Objects.
6. Select all .ggfx files and click Open to import the three LBSM global objects as shown.

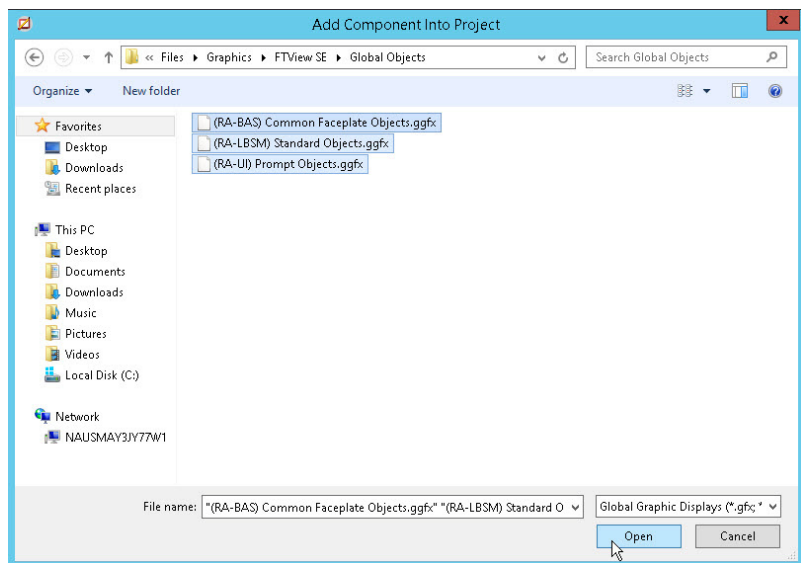



## Import HMI Displays

LBSM displays depict a batch procedure. Complete these steps to import displays.

1. Right-click Displays and choose Add Component Into Application.

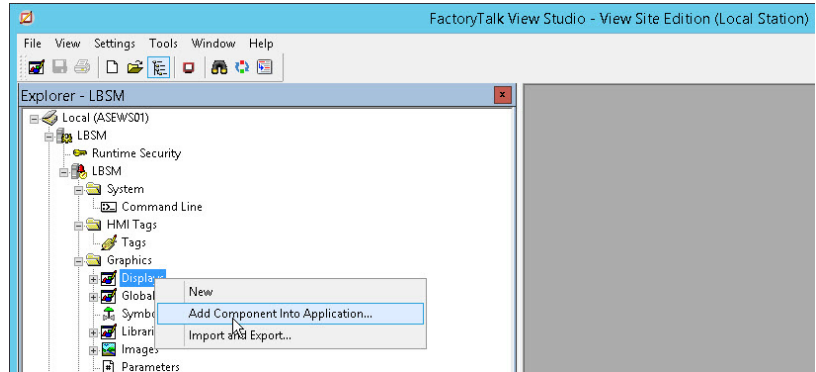

The Add Component Into Project dialog box appears.

2. Browse to your downloaded graphics folder.
3. Open the graphics folder and double-click the FTView SE folder.
4. Double-click GFX and select all \*.gfx files.

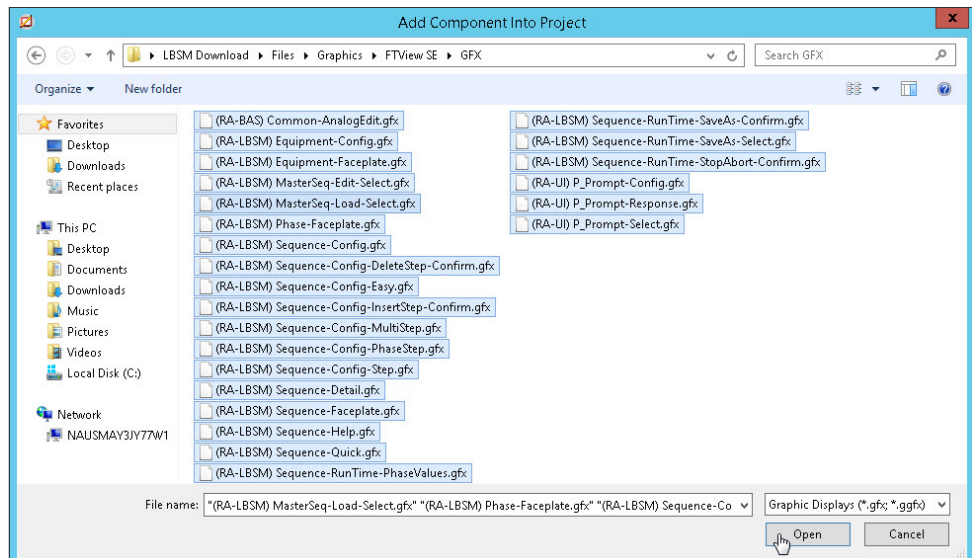

5. Click Open.

## Add HMI Tags to the Application

Import HMI tags so you can switch between tabs on the faceplates.

**TIP** FactoryTalk View SE is used in the following procedures. The instructions are similar for FactoryTalk View ME projects.

1. In FactoryTalk View Studio software, from the Tools menu, choose Tag Import and Export Wizard.

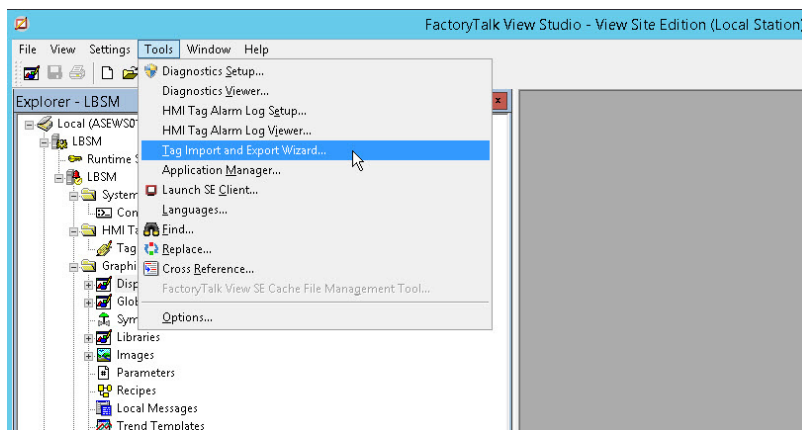

The Tag Import and Export Wizard dialog box appears.

2. From the Operation pull-down menu, choose Import FactoryTalk View tag CSV files.

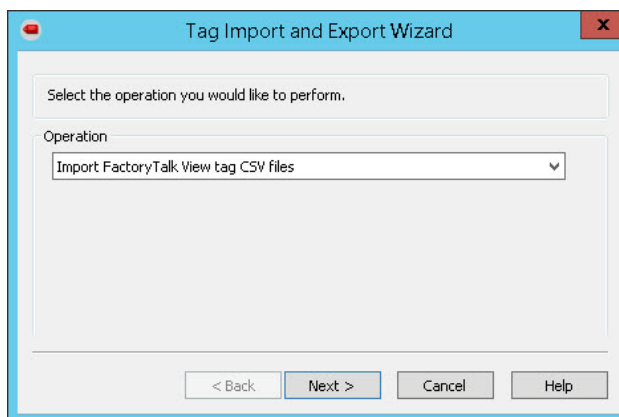

3. Click Next.
4. From the Project type pull-down menu, choose Site Edition or Machine Edition depending on your application.

5. Browse for and select your FactoryTalk View SE project file, and then click Next.

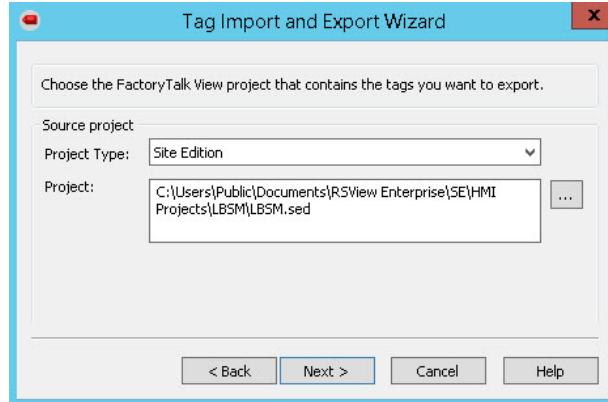

6. Check Tags
7. Browse for and select the RAProcessLibrary-Tags.CSV file, and then click Next

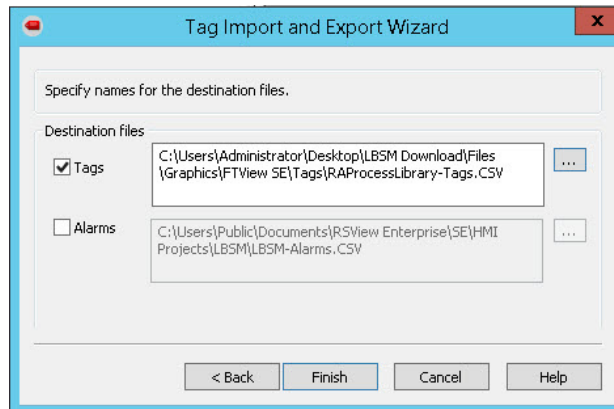

8. Click Skip existing (fastest), and then click Next.
9. Click Finish to import the HMI files.

## 10. Configure communication with your Logix controllers.

The LBSM application uses direct reference tags. A shortcut must exist in RSLinx® Enterprise software that is directed to the controller containing the LBSM tags. If you have installed the LBSM application in multiple controllers, you must create a shortcut for each controller. This shortcut name is used as a parameter in several global objects on the main display.

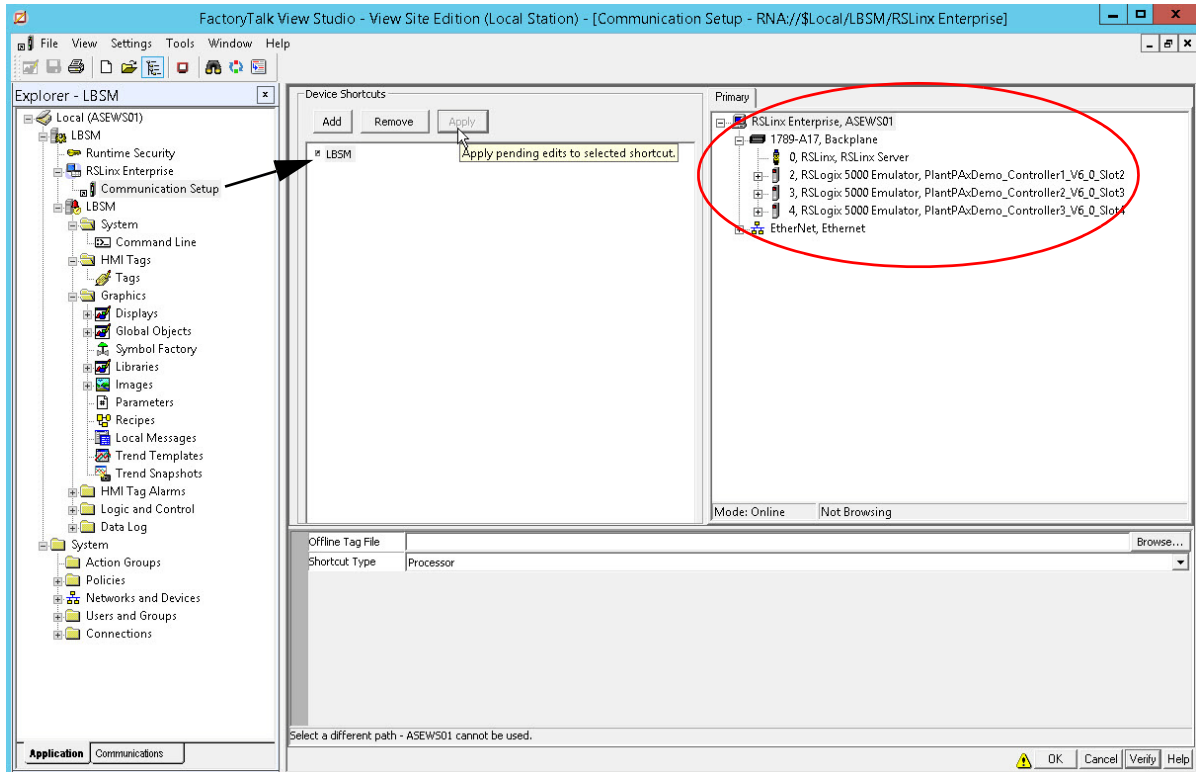

- a. To create a shortcut, right-click the LBSM server and choose Add New Server>Rockwell Automation® Device Server (RSLinx Enterprise).
- b. Click OK.  
A RSLinx Enterprise folder is added under the LBSM server folder.
- c. Click '+' to expand the RSLinx Enterprise folder, and double-click Communication Setup.  
The Communication Setup dialog box appears, with the controller information in the right-hand pane.
- d. Click Add and type a shortcut.
- e. Select a controller and click Apply at the top of the dialog box.

11. In FactoryTalk View Studio, incorporate the unit global object into your application.

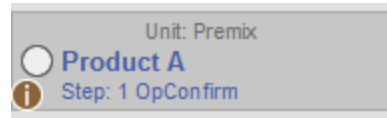

This object provides a unit summary with the following information:

- Runtime status (white circle)
  - Current step in the Control Recipe (runtime sequence)
  - Running state of the batch (inverted exclamation point indicates prompt)
12. To add navigation to the object, right-click, and choose Global Object Parameter Values.

**Figure 8 - Global Objects Parameters Values Table**

	Name	Value	Tag	Description
1	#101	::[LBSM]	...	The Shortcut name for the Controller, including the braces [
2	#102	{::[LBSM]_LBSMUnit[0]}	...	Unit UDT (includes full path)
3	#120	/x290	...	Additional display parameter (e.g. /X100 or /CC) (optional)
4	#121	/y0	...	Additional display parameter (e.g. /Y100) (optional)
5	#122	1	...	0 = Always show Faceplate; 1= Show Quick Display for users

- a. Replace parameter #101 with your shortcut name entered in [step 10](#).
- b. Replace parameter #102 with the full path of the unit UDT.
- c. Parameters #120 and #121 are optional; define position of the faceplate.
- d. Type a value (0, 1, 2) in parameter #122 per the desired display for the faceplate.
- e. Click OK.
- f. Repeat [Step 12](#) for all objects on the display.

## Configure LBSM (size arrays)

You can size arrays for the elements that comprise the application, such as the maximum number of units, equipment phases, sequence steps, and so on. The size of your recipe/sequence affects the amount of memory that is required for the controller that operates your application. For example, four units with 16 phases each requires more memory usage than two units with five phases per unit.

Therefore, to make sure that you have the correct controller with sufficient memory, you must first identify the units in your application. A unit is a group of equipment that works together to perform a major processing activity.

---

**IMPORTANT** If multiple units reside in a controller, assign each unit a unique number, starting with zero. This number correlates your equipment with a specific array memory location in the controller. This correlation is essential for implementing the logic to run your equipment. See [page 55](#) for more information.

---

## Modify the Data Structure

The LBSM ACD file, which is included with the download, has User-defined Data Types (UDT) that contain arrays. The arrays let you enter a numeric value to modify the size. For example, the LBSM\_Unit[6] UDT indicates that there are six independent units for a project.

These four UDTs determine the following arrays (up to system maximums) for your application:

- LBSM\_Unit – Number of units in the project
- LBSM\_Equipment – Number of phases per unit
- LBSM\_SQm – Number of master recipes per unit
- LBSM\_SQ\_Config – Number of steps and prompts per sequence

### Number of Units

Complete these steps to set the number of units.

1. Open the LBSM ACD file in the Logix Designer application and double-click Controller Tags in the left Controller Organizer pane.

The tags appear in the right pane.

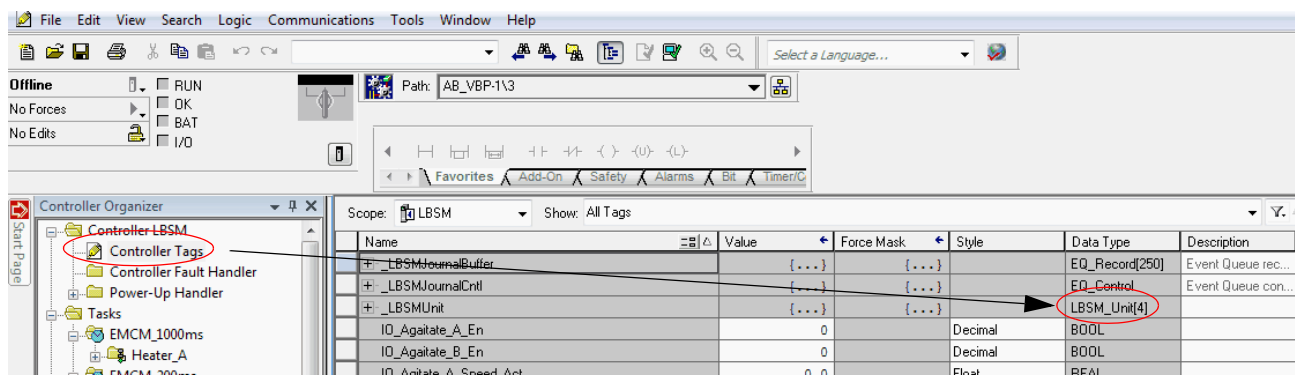

2. In the Data Type column, change the value in the brackets for the LBSM\_Unit[x] UDT.
3. Click File>Save.

### Number of Phases

Complete these steps to modify the maximum number of phases per unit.

1. In the Logix Designer application, scroll down the Controller Organizer and click to expand Data Types.

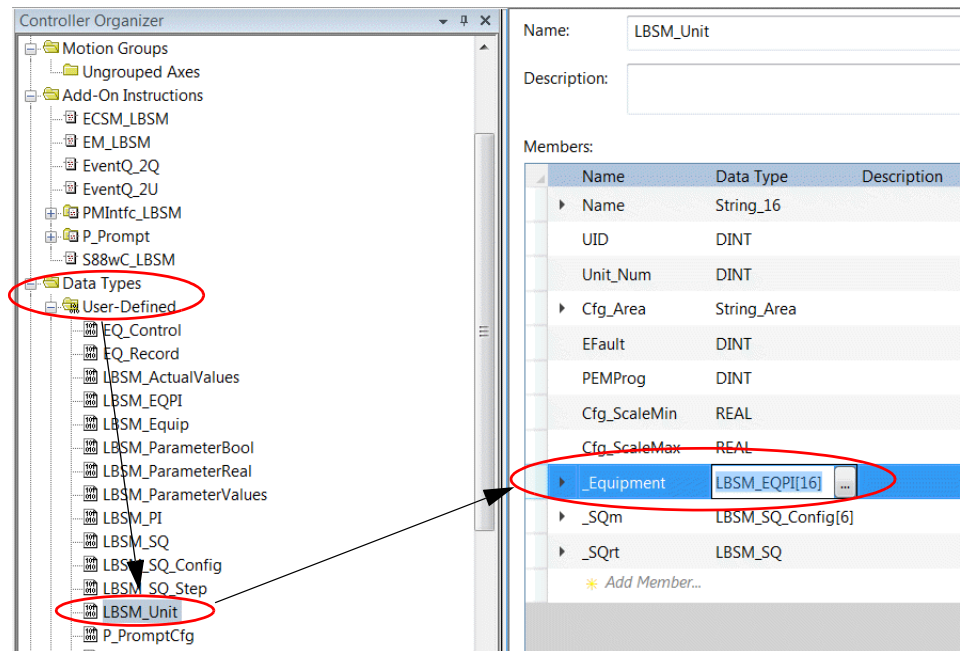

2. Click to expand User-Defined.
3. Double-click LBSM\_Unit and change the value in the brackets for the LBSM\_EQPI[x] array within the \_Equipment UDT.
4. Click File>Save.

### Number of Recipes

Complete these steps to modify the maximum number of recipes per unit.

1. In the Logix Designer application, scroll down the Controller Organizer and click to expand Data Types.

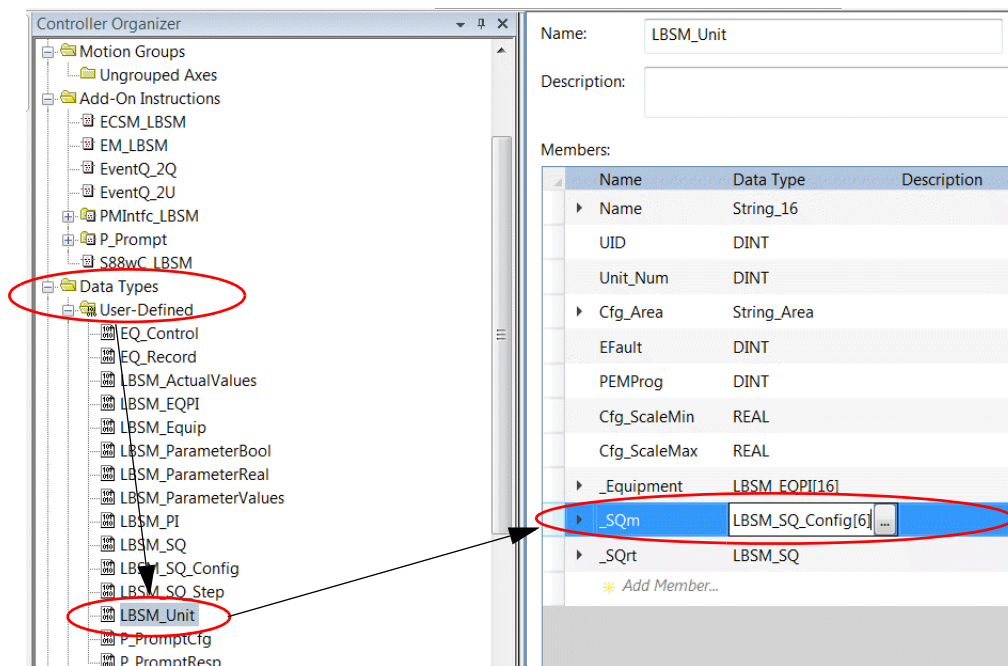

2. Click to expand User-Defined.
3. Double-click LBSM\_Unit and change the value in the brackets for the LBSM\_SQ\_Config[x] array within the \_SQm UDT.
4. Click File>Save.



## Number of Steps

Complete these steps to modify the maximum number of steps (32) per unit.

1. In the Logix Designer application, scroll down the Controller Organizer and click to expand Data Types.

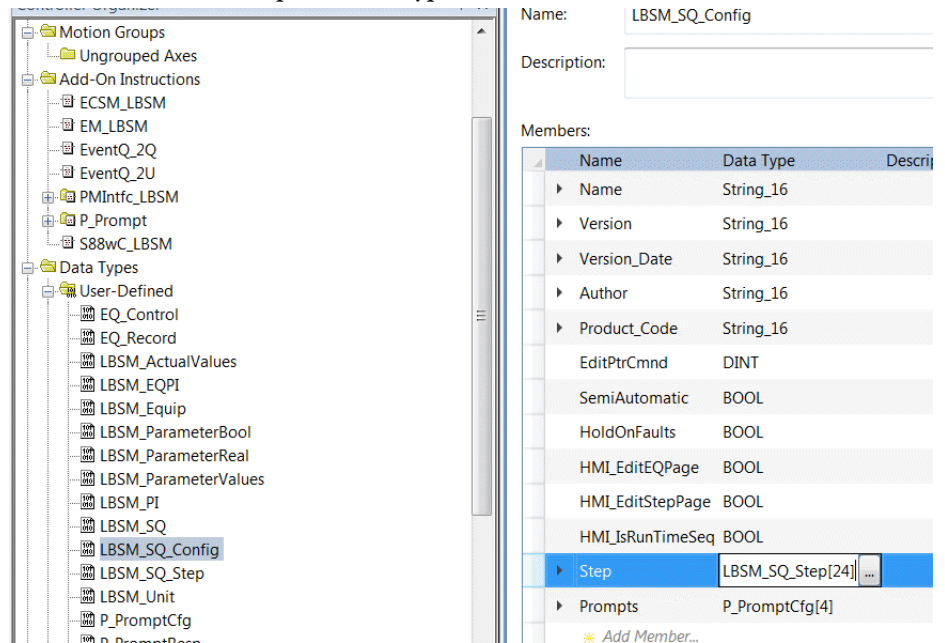

2. Click to expand User-Defined.
3. Double-click LBSM\_SQ\_Config and change the value in the brackets for the LBSM\_SQ\_Step[x] array within the Step tag.
4. Click File>Save.

## Number of Prompts

Complete these steps to modify the maximum number of prompts per unit.

1. In the Logix Designer application, scroll down the Controller Organizer and click to expand Data Types.

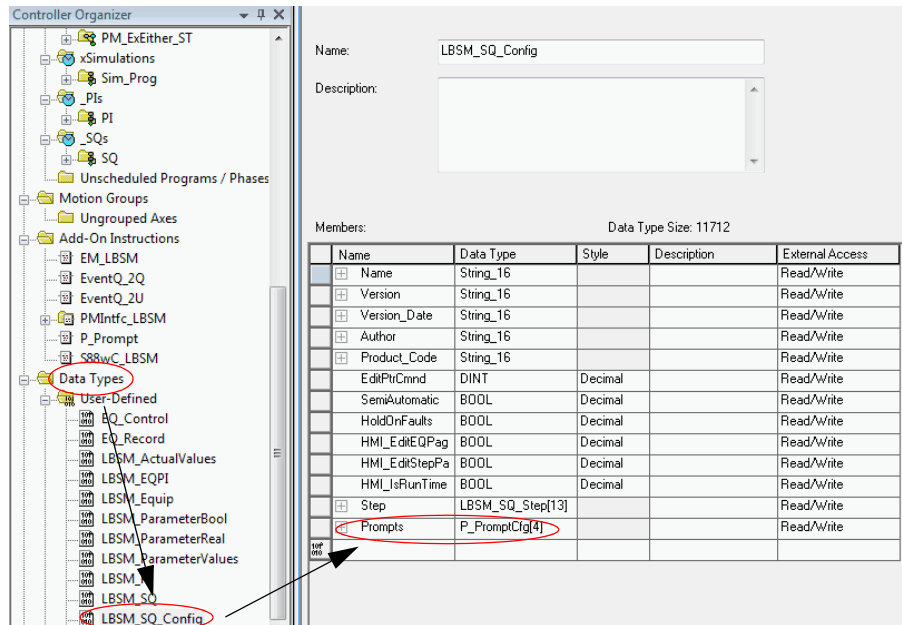

2. Click to expand User-Defined.
3. Double-click LBSM\_SQ\_Config and change the value in the brackets for the P\_PromptCfg[x] array within the Prompts tag.
4. Click File> Save.

## Unit Configuration

After you have sized the arrays, you are ready to configure a unit in your LBSM application. You must have engineering configuration security to modify the unit configuration.

1. On the Operator tab, click the Display Advanced Properties button.

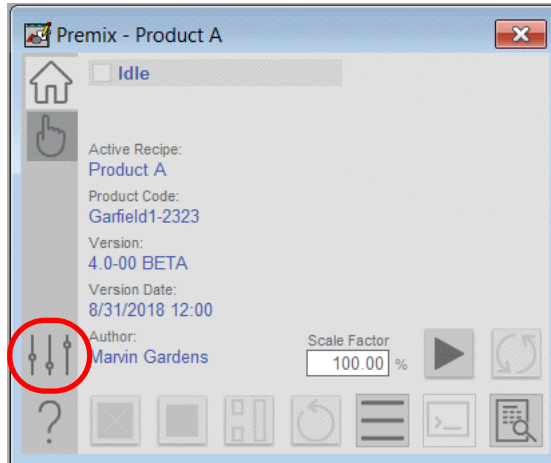

The Engineering tab appears.

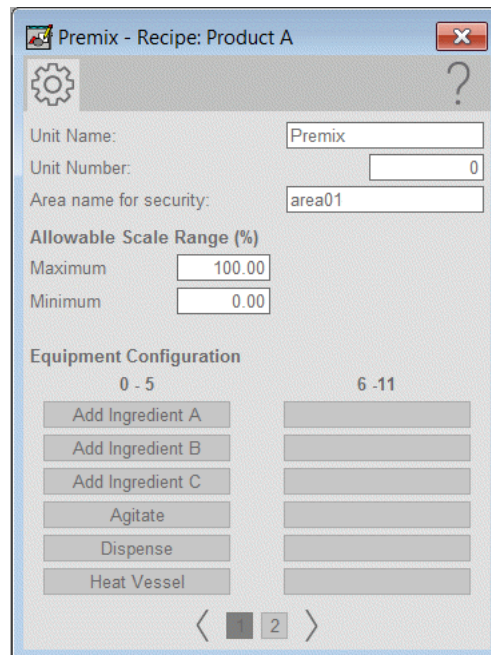

2. Configure the unit on the Engineering tab faceplate.

**Table 5 - Unit Configuration Description**

Topic	Description
Unit Name	Type a name for the unit.
Unit Number	Type a unit number. <b>IMPORTANT:</b> This is the unit number that is used to identify the equipment in your facility, not the unit index used in the controller array.
Allowable Scale Range (%) Minimum Maximum	The allowable scale range limits the 'Scale' input that affects 'Scaled' configuration in equipment. Click the Minimum and Maximum boxes to access a calculator for entering values for the scale range.

## User-defined Data Types

These LBSM\_Unit user-defined data types (UDTs) define the number of equipment phases per unit (\_Equipment) and the number of master recipes (\_SQm) in each unit; 32 maximum.

The maximum step count per phase is 32; there is no step array.

## Operator Prompt

An embedded prompt instruction is included with the LBSM ACD file to perform prompting. The prompt lets an operator interact with a running phase in various ways, including entering values, verifying data, or providing directions to perform a task.

The number of manual prompts available for a unit is configurable, up to 32. The default number is four.

## Phase Configuration

This section describes how to define phases in a unit. Phases are the process actions that comprise the batch. You must have engineering configuration security to modify phase definitions.

See [HMI Security Codes on page 101](#) for a list of descriptions.

---

**IMPORTANT** The order that you list the equipment on the Equipment Phase Configuration display is not relative to the recipe. However, the equipment order **must** correspond to the mapping in the controller, as shown on [page 55](#).

---

1. On the Engineering tab, click an Equipment Configuration button.

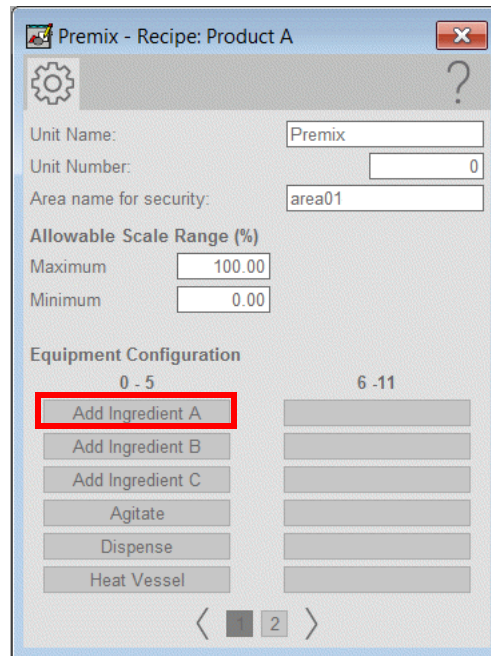

The value that is entered in the array of the LBSM\_Equipment UDT determines the number of columns for phases. See [page 31](#).

The Phase Configuration display appears when an Equipment Configuration button is clicked.

**Premix - Equipment: Ingredient A**

Equipment Name:  Phase Name:

**Real Parameters**

Phase	EM	Name	EU	Low	High	Scaled	Default
<input checked="" type="checkbox"/>	<input checked="" type="checkbox"/>	<input type="text" value="Bulk Slurry"/>	<input type="text" value="Buckets"/>	<input type="text" value="0.00"/>	<input type="text" value="4000.00"/>	<input checked="" type="checkbox"/>	
<input type="checkbox"/>	<input type="checkbox"/>	<input type="text"/>	<input type="text"/>	<input type="text" value="0.00"/>	<input type="text" value="100.00"/>	<input type="checkbox"/>	<input type="text" value="0.00"/>
<input type="checkbox"/>	<input type="checkbox"/>	<input type="text"/>	<input type="text"/>	<input type="text" value="0.00"/>	<input type="text" value="100.00"/>	<input type="checkbox"/>	<input type="text" value="0.00"/>
<input type="checkbox"/>	<input type="checkbox"/>	<input type="text"/>	<input type="text"/>	<input type="text" value="0.00"/>	<input type="text" value="100.00"/>	<input type="checkbox"/>	<input type="text" value="0.00"/>

**Boolean Parameters**

Phase	EM	Name	Off State	Default	On State
<input type="checkbox"/>	<input type="checkbox"/>	<input type="text"/>	<input checked="" type="radio"/>	<input type="text"/>	<input type="radio"/>
<input type="checkbox"/>	<input type="checkbox"/>	<input type="text"/>	<input checked="" type="radio"/>	<input type="text"/>	<input type="radio"/>
<input type="checkbox"/>	<input type="checkbox"/>	<input type="text"/>	<input checked="" type="radio"/>	<input type="text"/>	<input type="radio"/>
<input type="checkbox"/>	<input type="checkbox"/>	<input type="text"/>	<input checked="" type="radio"/>	<input type="text"/>	<input type="radio"/>

**Reports**

Phase	EM	Name	EU
<input checked="" type="checkbox"/>	<input checked="" type="checkbox"/>	<input type="text" value="Bulk Slurry Amt"/>	<input type="text" value="Buckets"/>
<input type="checkbox"/>	<input type="checkbox"/>	<input type="text"/>	<input type="text"/>
<input type="checkbox"/>	<input type="checkbox"/>	<input type="text"/>	<input type="text"/>
<input type="checkbox"/>	<input type="checkbox"/>	<input type="text"/>	<input type="text"/>

2. Complete the Phase Configuration display.

**Table 6 - Phase Configuration Description**

Topic	Description
Equipment Name	Type a name for the equipment. Phase columns without names are unused placeholders.
Phase Name	Type a name for a phase. The name is often the same as the equipment name, but separate configurations have been provided if you want a different name for a phase.

**Real Parameters**

These are values in the formula, such as setpoints. Up to four Real parameters can be configured per phase. Each defined value is captured for reporting when the phase starts. You can configure these items for each parameter.

Phase	Check to indicate that the parameter belongs to the phase. The parameters are exposed to the recipe author. <b>IMPORTANT:</b> Phase parameters can be changed from the Equipment Phase Configuration display or the Run Time Detail faceplate.
EM	Click to indicate that the parameter belongs to the equipment module. The parameters are configurable attributes but not available for recipe configuration. <b>IMPORTANT:</b> Equipment module parameters can be modified only from the Run Time Detail faceplate.
Name	Type a name for the parameter.
EU	Type an engineering unit for the parameter.

**Table 6 - Phase Configuration Description**

Topic	Description
Low High	Type a low value and a high value to set an operational range for the parameter. These values limit the entries when configuring a step or manually controlling the equipment. For example, you can set the high limit for a mixer speed of 30 if the mixer cannot exceed 30 rpm.
Scaled	Check if the parameter value is to be scaled up or down when the scale factor for the batch is changed from 100%. Leave the box blank if the parameter value is to be the same when the batch is scaled.
Default	Default values are constants that can be set when values are not expected to be used by an operator, maintenance personnel, sequence, or formulation. For example, you can change the temperature value to accommodate the physical equipment when commissioning. Large vats can require 10° while smaller vats can require 2°. <b>IMPORTANT:</b> A default value is <b>not</b> considered a phase or an equipment module parameter. Leave the Phase and EM boxes blank if you configure a default value.

If you use Real parameters, the equipment module code must be configured to interface with these LBSM parameters. Refer to [Connect Equipment to Controller Logic on page 55](#) and [Equipment Interface Codes on page 89](#).

#### Boolean Parameters

These are discrete values that the equipment phase sends to the equipment module, such as a mode selection. Each defined value is captured for reporting when the phase starts. Up to four Boolean parameters can be configured per phase. You can configure these items for each parameter.

Phase	Check to indicate that the parameter belongs to the phase. The parameters are exposed to the recipe author. <b>IMPORTANT:</b> Phase parameters can be changed from the Equipment Phase Configuration display or the Run Time Detail faceplate.
EM	Click to indicate that the parameter belongs to the equipment module. These parameters are configurable attributes but are not available for recipe configuration. <b>IMPORTANT:</b> Equipment module parameters can be modified only from the Run Time Detail faceplate.
Name	Type a name for the parameter.
Default	Default is used for configurations that do not need to be accessed from the Run Time Detail faceplate. The configuration can default to either Off or On state. In this situation, the parameter is not considered a phase or equipment module parameter.
Off State	The logic state descriptor for the Off state.
Default	See Off State.
On State	The logic state descriptor for the On state.

If Boolean parameters are used, the equipment module code must be configured to interface with these LBSM parameters. Refer to [Connect Equipment to Controller Logic on page 55](#) and [Equipment Interface Codes on page 89](#).

**Table 6 - Phase Configuration Description**

Topic	Description
<b>Report Parameters</b>	
These are values that the equipment phase captures for reporting when the phase completes. For example, the actual amount of a material the equipment adds. You can configure these items for each parameter.	
Phase EM	Similar to Real and Boolean parameters, check to indicate that the parameter belongs to the phase, the equipment module, or both. <b>IMPORTANT:</b> Phase parameters appear on the Run Phase display that is accessed from the Run Time Detail faceplate. Equipment parameters appear on the Equipment Module display that is accessed from the equipment icon at the top of the Phase faceplate.
Name	Type a name for the parameter.
EU	Type an engineering unit for the parameter.

If required by the equipment phase, the equipment module code must be configured to the interface with these LBSM parameters. Refer to [Connect Equipment to Controller Logic on page 55](#) and [Equipment Interface Codes on page 89](#).

## Configure a Master Recipe

This section describes how to configure the procedural steps in a recipe. The current runtime sequence, which is the Control Recipe, manages the interaction of the phases to make product.

**IMPORTANT** Changes to a Control Recipe are not saved at the completion of a batch. You **must** use the Save As button to save the revised recipe as a Master Recipe. See [page 53](#) for procedures.

1. On the Operator tab, click the Manual Control tab.

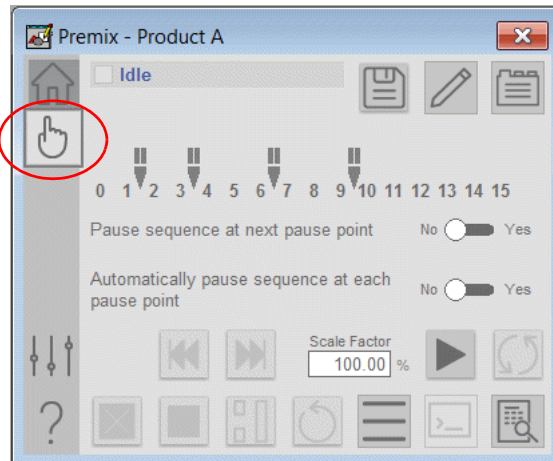



2. Click the Master Sequence Edit button.

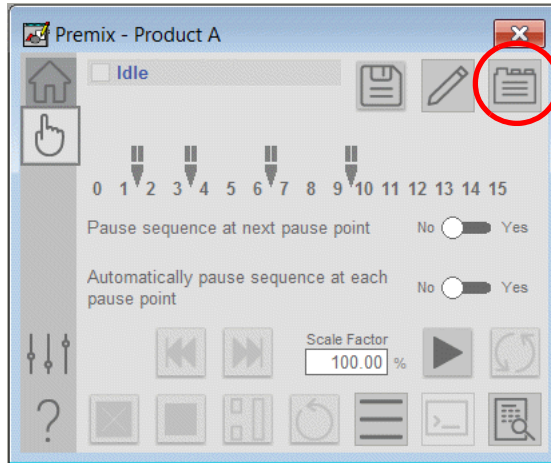

The Edit Master Sequence popup appears.

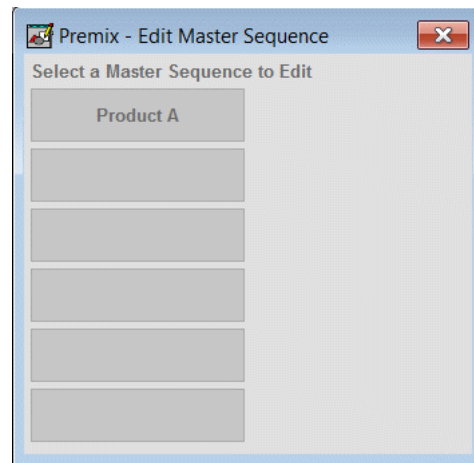

The number of master recipes available in the list is set by the value in the array for the LBSM\_SQm UDT (see [page 32](#)).

3. Do one of the following:
- Click a blank master to create a master recipe.
  - Click an existing master to make a copy and edit the recipe.

The Recipe Configuration display appears.

The Product A Master Recipe from the LBSM demonstration, starting on [page 69](#), is shown in the graphic.

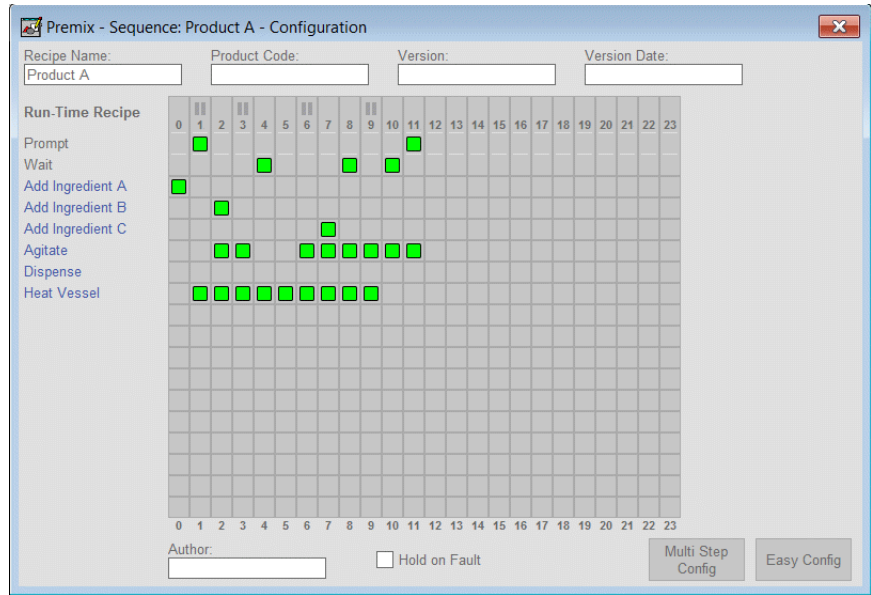

- To configure a step in a recipe, click the top of a numerical column – 0, 1, 2, 3, 4, and so on.

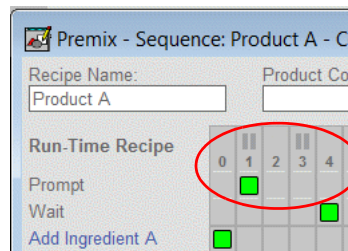

The Step Configuration display appears for the numbered step that you clicked. The example shows step 4.

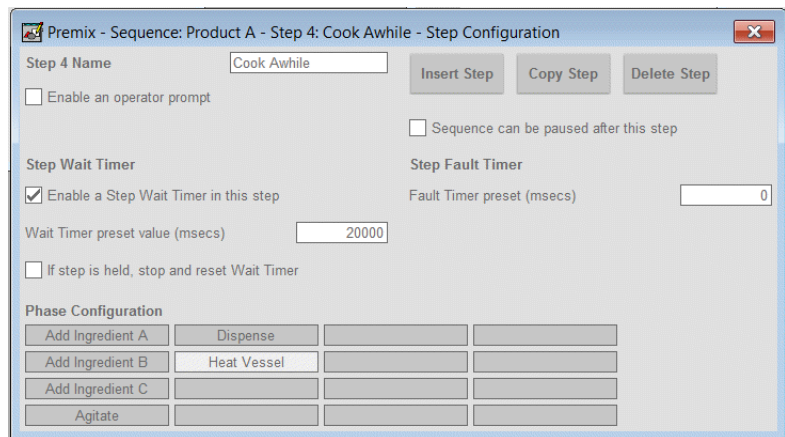

5. For each step, complete the display for the actions to be taken to accomplish the step.

**Table 7 - Step Configuration Description**

Topic	Description
Step x Name	Type a name for the step.
Enable an operator prompt	Check to enable an operator prompt for the step. A blank box appears. Click the box to type a name for the prompt for the step. See <a href="#">Built-in Phases on page 46</a> .
<b>Step Wait Timer</b>	
Enable a Step Wait Timer in this step	Check to enable a step wait based on the conditions of the additional entry fields that display. See <a href="#">Set a Wait Timer on page 50</a> .
Wait Timer preset value (msecs)	Type a value to set a time frame for the wait. <b>IMPORTANT:</b> A setpoint of '0' disables the timer.
If step is held, stop and reset Wait Timer	Check to reset the Wait Timer if step is in a Held state.
Insert Step	Click to add a step before to the current step. A message box appears that states to Insert a new step before step x (Name). Click OK or Cancel.
Delete Step	Click to delete this step from the sequence. A message box appears stating Are you sure you want to DELETE step x (Name)? Click Yes or No.
Copy Step	Click to copy the previous step and insert it before the current step. A message box appears that states Copy the previous step and insert it before step x (Name)? Click OK or Cancel.
Sequence can be paused after this step	Check to enable a pause point after this step in the sequence. See <a href="#">Using Pause and Skip on page 45</a> .
<b>Step Fault Timer</b>	
Fault Timer preset (msecs)	Type a value to trigger a fault if the time to complete this step exceeds the timer setting.
<b>Phase Configuration</b>	
Equipment Phase (for example, agitation)	Click the equipment phase to access the Phase Configuration faceplate. See <a href="#">Setting Phase Parameters</a> .

6. Repeat [step 4](#) and [step 5](#) for each step in the recipe/sequence.

## Setting Phase Parameters

You can configure and maintain parameter values in the entry boxes for each phase instance.

1. Click a phase at the bottom of the Step Configuration display.

A Phase Configuration display appears.

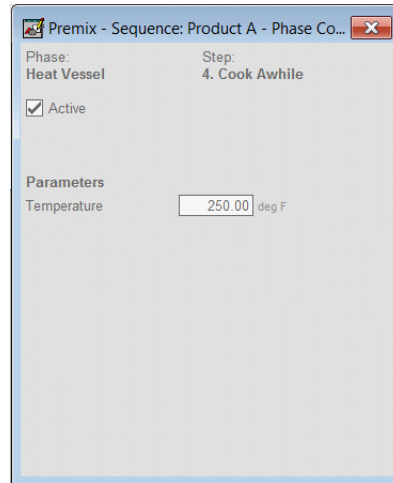

2. Check the Active box to enable the phase in this step.
3. Click the parameter value to open the keypad entry display.
4. Type a value and click OK.

---

**IMPORTANT** Once the phases are configured for a batch, the LBSM application provides operator control in a runtime environment to users with manual operation security privileges. See [page 62](#).

---

## Using Pause and Skip

When organizing your recipe, this functionality helps you move around to different phases without having to run each step.

When you enable a pause for a step on the Step Configuration display, a symbol  appears to indicate where the pause occurs in the sequence. You can then skip to this pause point.

Complete these steps to activate the Pause Control buttons.

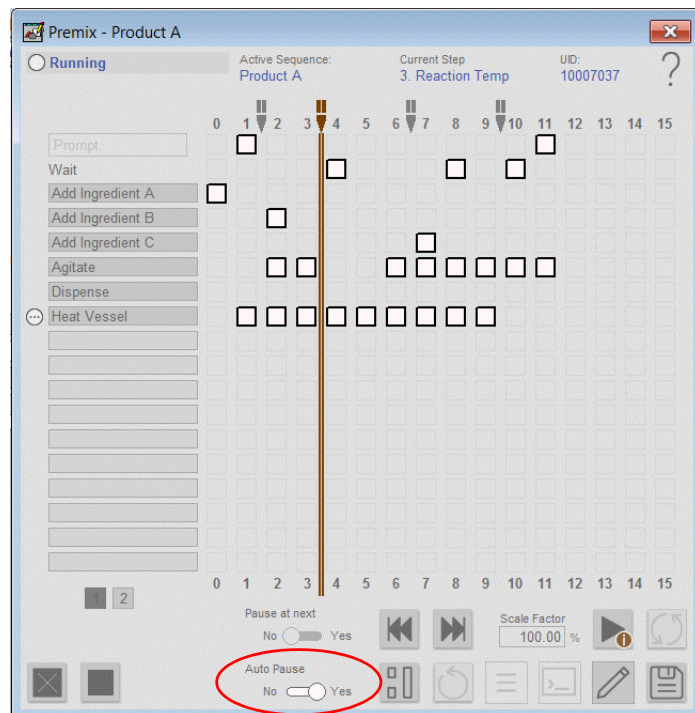

1. Switch the Auto Pause toggle bar to Yes to request the sequence to stop at the next configured pause point.

When the sequence reaches the next pause point, the sequence pauses, symbol turns brown, and the Pause Control buttons activate.



2. Review the functionality of the Pause Control buttons.

**Pause Control Button Description**

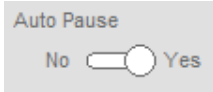
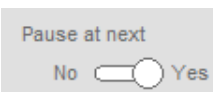
Topic	Description
	Click to skip to the previous pause point.
	Click to skip to the next pause point.
	Click to resume the sequence. Once resumed, the sequence does not pause at a configured pause point until another pause request is issued or an auto pause is requested.
	Switch the auto pause toggle bar to Yes to request the sequence to stop at every configured pause point.
	Switch the auto pause toggle bar to Yes to request the sequence to stop at the next configured pause point.

**Built-in Phases**

There are two built-in phases with the LBSM application:

- Prompt
- Wait Timer

*Configure a Prompt Instance in the Procedure*

You can configure the LBSM application to prompt an operator and then wait for operator input before proceeding with the procedure. You can configure each instance of the prompt to include instructions for an operator, expected or desired values for selected parameters, and operator input.

1. On the Step Configuration display, click the name of the prompt.

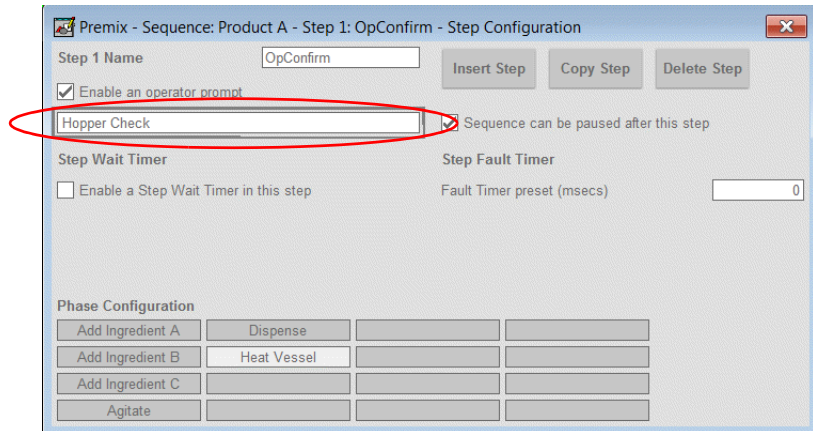

2. On the Prompt popup, click Browse (button with ellipsis) to open the Prompt Configuration display.

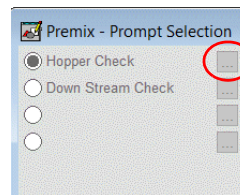

### 3. Complete the Prompt Configuration display.

Topic	Action
Manual Prompt Label	Type a label for the prompt.
Prompt Message Text	Type a text message that explains to the operator the purpose of this prompt.
Do not show the “Operator Attention” symbol on the Prompt button (applies to standalone prompts only)	Check <b>not</b> to show the operator attention symbol (inverted exclamation point) on the prompt button.
<b>Display Values</b> – This prompt shows an operator floating point values in run time. This informs the operator of specific quantities or operating conditions. An Entered Value can be scaled by a programmatic percentage.	
Display Value Enable	Check to enable a Label text field.
Label	Type a label.
Engineering Units	Type an engineering unit.
Decimal Places	Type the number of decimal places to be used.
Display Value Source	Check to either display a value from the prompt 'AOI Input' or the value that you enter in the box that appears.
• 'AOI Input'	
• Entered Value	
Scale Value	The LBSM application sets the Inp_ScalePct to the value of its scaling when a recipe transitions to 'Run'.
Verify Required	Check to require the operator to verify the displayed value.
<b>Input Values</b> – Input values let the operator enter floating point values via the prompt that are used programmatically. Minimum and maximum values are entered for a range. Value entry can be optionally required (default)	
Input Value Enable	Check to enable a Label text box.
Label	Type a label for the input value.
Engineering Units	Type an engineering unit.
Decimal Places	Type the number of decimal places to be used.
Minimum Value	Type a minimum value for the entry.



Topic	Action
Maximum Value	Type a maximum value for the entry.
Input Required	Check to require an operator to enter a value.
Default Uses <ul style="list-style-type: none"> <li>• Min</li> <li>• Max</li> </ul>	If an input is not required, click Minimum or Maximum to be used for the entry.
<b>Selection Options</b> – Selection options give an operator a choice from two to four offerings. One of the selections can be designated a default. You do not need to designate any of the selections as default.	
Selection Enable	Check to enable a Label text box.
Label	Check and type a label for the selection option.
Default Selections	Click to designate a selection as the default.
<b>Response Prompts</b> – Response prompts let the operator enter string-based information (comments, lot numbers, and so forth). Response entry is required by default, but can be configured as optional.	
Response Enable	Check to enable a Label text box.
Label	Check and type a label for the response prompt.
Input Required	Check to require an input.

**Figure 9 - Operator Interaction Example**

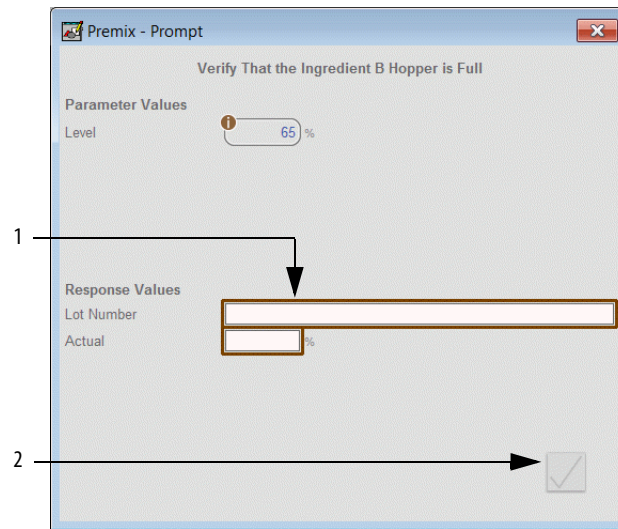

Item	Description
1	Required entry field (Brown highlight around box indicates it is a required entry)
2	Acknowledge prompt and proceed (Acknowledgment prompt activates once all required inputs are entered)

### Set a Wait Timer

You can use a wait phase to force the sequence to stay in a step for a preset amount of time. By setting a preset value on the Step Configuration display, the timer starts counting down when the step that contains the Wait Timer becomes active. The remaining wait time is displayed in seconds.

You can configure the Wait Timer to reset on hold, if desired.

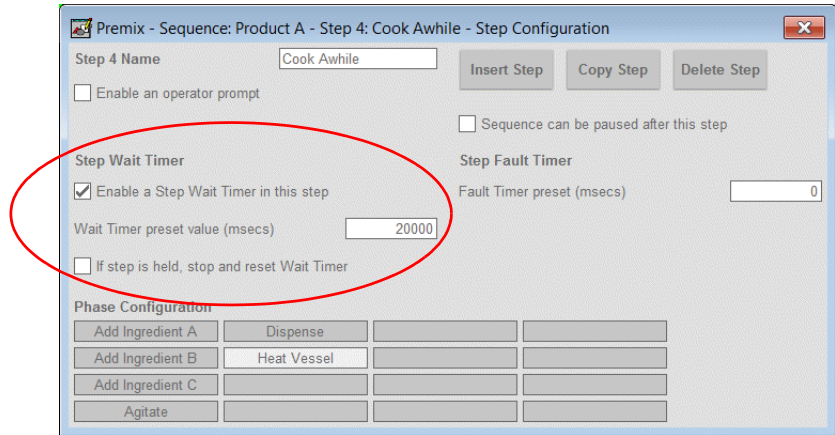

When active, the timer counts down on the run-time detail faceplate.

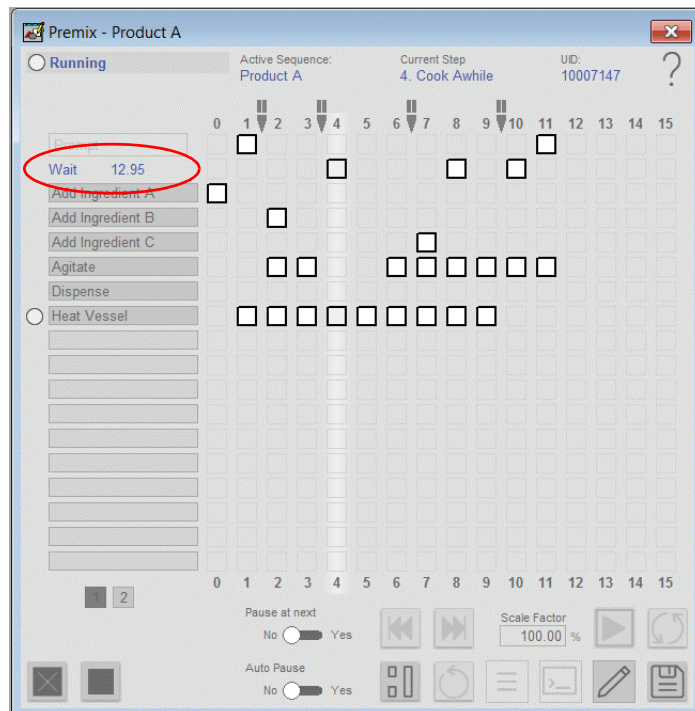

## Create a Batch

To create a batch, select a recipe and define the batch size.

1. On the Operator tab, click the Master Sequence List button.

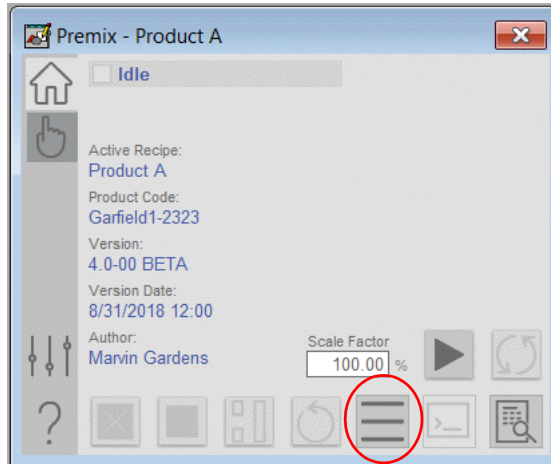

The Load Master Sequence display appears.

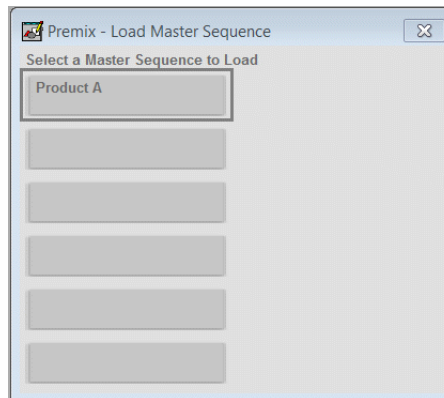

2. Choose a recipe by clicking the respective Master Sequence List button.

The Operator tab appears with the recipe information on the display.

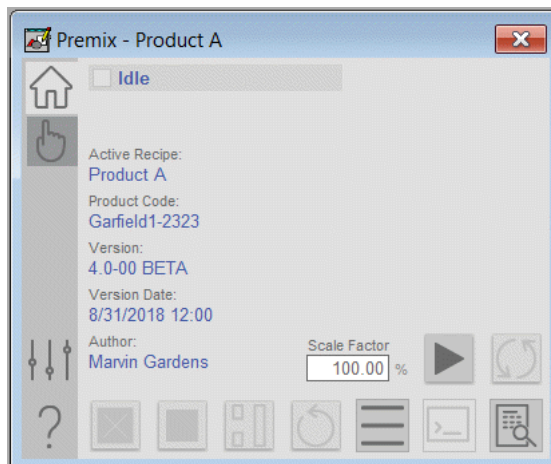

3. In the Scale Factor entry box, type a value.  
Default value is 100%.
4. Click the Start Command button to begin operating the batch.  
See the demonstration on [page 69](#).

## Save Master Recipe

Changes applied to a Control Recipe can be saved to a Master Recipe if you want to use the same data for other batches. Complete these steps.

1. On the Run Time Detail faceplate, click the Save As button.

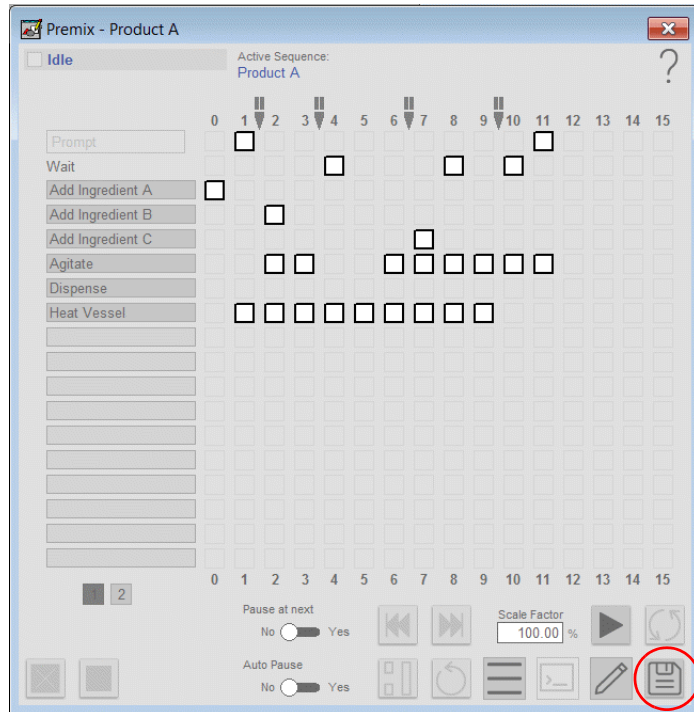

The Save Sequence As window appears.

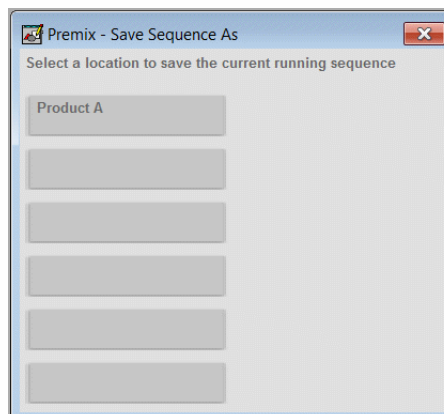

2. Click a button to save the current recipe as a new Master recipe. If you click an empty button, the recipe saves to that slot. If you click the currently loaded product slot a warning message displays.

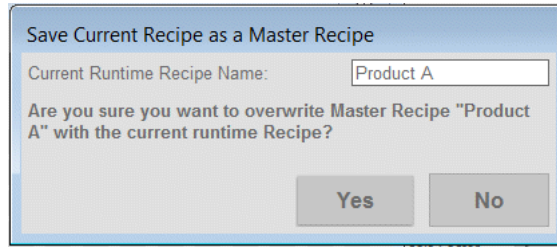

3. To overwrite the current recipe, type a name for the new master recipe and press the Yes button.

---

**IMPORTANT** Make sure to upload your changes in the Logix Designer application after modifying your Master Recipe.

---

## Connect Equipment to Controller Logic

The LBSM application interfaces to your equipment through a tag named `_Equipment`. This tag is an array that is composed of two data types:

- EM\_Composite (see list of interface codes on [page 89](#))
- PIDefinition

These data types store the configuration for your equipment phase instances. The objects on the Equipment Configuration display align with the members of this array. For example, the equipment phases for the first unit (unit 0) align with the `_Equipment` array as illustrated.

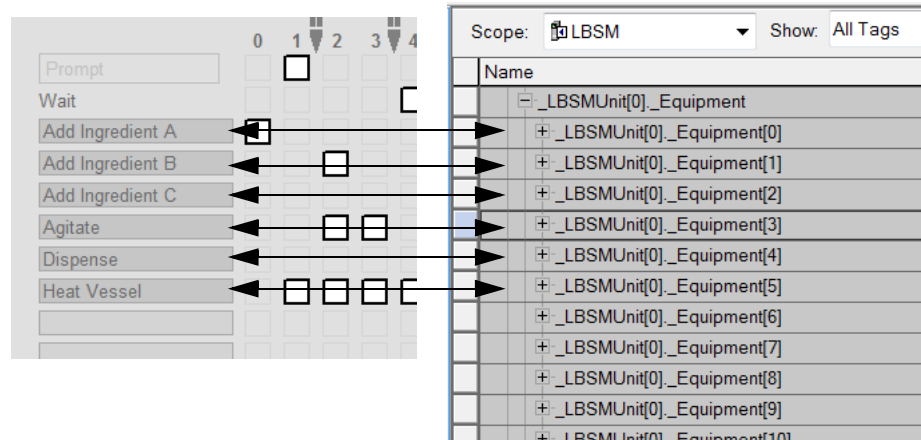

Expanding `_Equipment[3]` reveals how the `_Equipment` array aligns with several other objects on the Equipment Configuration display for the phase instance of the first unit instance [0].

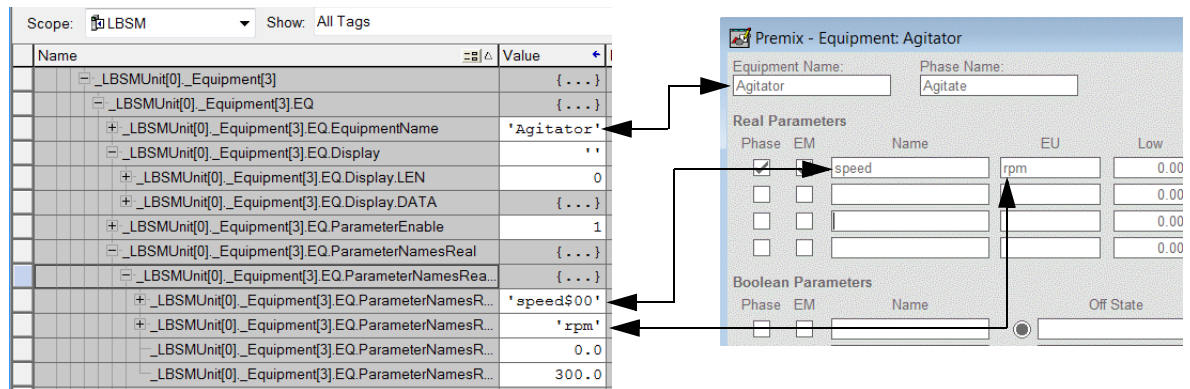

The LBSM application supports two equipment interfaces to your selected controller:

- PhaseManager – see [page 56](#)
- Bit Interface – see [page 58](#)

Depending on your equipment need, choose the appropriate interface. You can use either one or both in any application.

## PhaseManager Interface

Prior to LBSM version 3.x, the interface to PhaseManager consisted of a routine of fixed code and a JSR to execute that code. This routine had to be placed into each Phase Manager phase to be controlled.

To reduce the required memory, this routine is replaced by an Add-On Instruction, PMIntfc\_LBSM. The Add-On Instruction creates an instance of the interface without additional programming.



Complete these steps to create the PMIntfc\_LBSM interface.

1. Import the PMIntfc\_LBSM Add-On Instruction definition into the project.
2. Create an instance of the Add-On Instruction in a routine in the Phase Manager phase to be controlled.

---

**IMPORTANT** If the PhaseManager ownership is used (PATT and PDET), then the PCmd commands have to be outside the phase.

---

3. Create the backing tag for the Add-On Instruction.
4. Associate the InOut parameters on the Add-On Instruction as shown in the table.

InOut Parameter	Description
ThisEquipmentDN	A bit to indicate when the equipment accomplishes what is requested (BOOL).
EP	Reference to the specific equipment tag structure (LBSM_EQPI).
ThisPhase	The name of the PhaseManager phase.
UNref	Standard name of the unit structure array (LBSM_Unit).



5. Program the outputs of the PMIntfc\_LBSM instruction to command the PhaseManager phase.

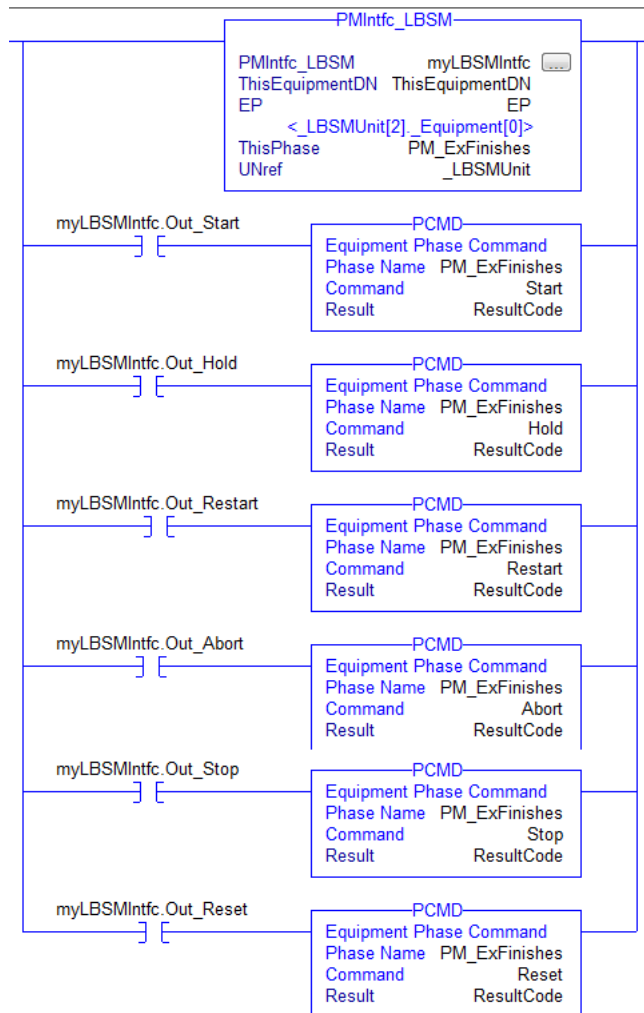

As stated in the Important for step 2, the PCMD commands can be in the PhaseManager phase program only if the 'Acquire' (PATT and PDET) and ownership is **not** used.

## Bit Interface

The Equipment Bit Interface consists of a number of inputs and/or outputs that are used to control and monitor your equipment when you're not using PhaseManager software. In this equipment, lower-level devices (such as control modules) are configured to perform some predefined function as one piece of equipment, or equipment module. This predefined Equipment Bit Interface provides a consistent way to connect custom user-coded equipment to the LBSM application.

These are the LBSM bits used by the interface.

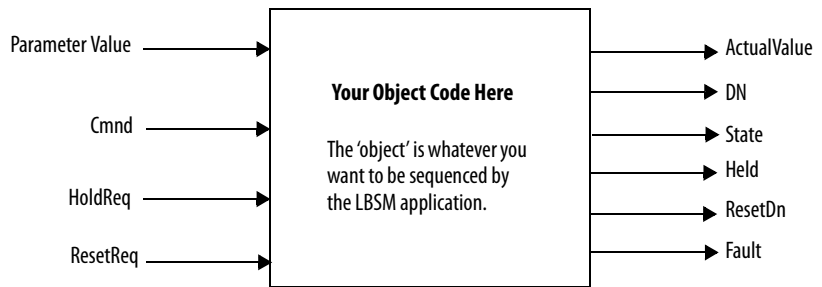

1. To begin using this interface, create a tag of type EM\_Composite for each equipment module.

The tag naming convention is up to you.

2. Alias the equipment tag to the corresponding LBSM equipment tags at the controller scope.

Using the example from the Equipment Configuration mapping section ([page 55](#)), the Equipment tag name Agitate is aliased to `_Equipment[3]`. Refer to this table.

Unit	Equipment Phase	Alias
0 = Premix	0 = Add Ingredient A	<code>_Equipment[0].EQ</code>
	1 = Add Ingredient B	<code>_Equipment[1].EQ</code>
	2 = Add Ingredient C	<code>_Equipment[2].EQ</code>
	3 = Agitate	<code>_Equipment[3].EQ</code>
	4 = Dispense	<code>_Equipment[4].EQ</code>
	5 = Heat Vessel	<code>_Equipment[5].EQ</code>
	6 = Blank	<code>_Equipment[6].EQ</code>
	7 = Blank	<code>_Equipment[7].EQ</code>
	8 = Blank	<code>_Equipment[8].EQ</code>

3. Use the equipment tags created in step 1 to program each equipment module interface with these bits.

Member	Data Type	Description
Cmnd	BOOL	Boolean inputs that command the object code to perform its primary function.
ParameterValues	ParameterValues	Inputs to the object code that can be modified from the HMI. For example, setpoints. You can use a maximum of four Real and four Boolean parameters.
HoldReq	BOOL	Boolean input that requests the object code to perform its Hold function. This could be to go to a known state or stay where it is (do nothing).
ResetReq	BOOL	Boolean input that requests the object code to reset; put the EM into a known initial state, ready to run again.
State	BOOL	Boolean output that indicates that the object code is Off (0) or On (1).
DN	BOOL	Boolean output that indicates that the object code has achieved its final state. <b>User program must always set this tag</b> at some point in the operation of the EM. See <a href="#">Use the DN and State Bits on page 60</a> .
Actual	ActualValues	Outputs saved for reporting.
ResetDN	BOOL	Boolean output that indicates that the object code has been reset caused by the setting of the ResetReq input.
Held	BOOL	Boolean output that indicates the object code is in a state caused by the setting of the HoldReq input.
Fault	BOOL	Indicates an object code fault. Could be the OR'ed composite of all code component faults.
Health	BOOL	Indicates bad object code health. Could be the OR'ed composite of all code component health bits (like CM IO health bits).

**IMPORTANT** Refer to Appendix A for details of the EM\_Composite data type. Refer to Appendix B for several example applications.

4. Add an instance of the EM\_LBSM Add-On Instruction to each equipment module.

The EM\_LBSM Add-On Instruction manages the equipment module modes and handshakes to the rest of the system. You **must** use this in each equipment module that you create.

## Use the DN and State Bits

The relationship between the DN and State bits is critical for the appropriate behavior of procedural handling of equipment entities. There are two distinct behaviors that can occur:

- Equipment completes (finish and be released)
- Equipment qualifies step and continues activity
- **Completion** – If DN = 1 and State = 0. This combination of bits instructs the engine that the equipment has finished what was requested (EM.DN=1) and is in a low state or de-energized (EM.State=0).

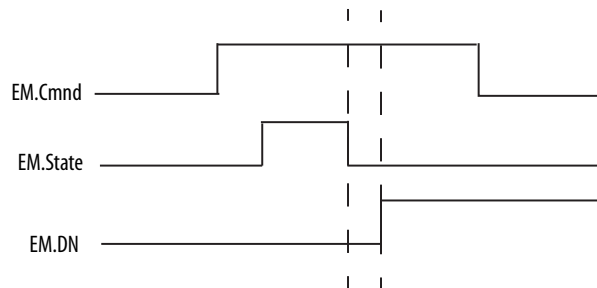

46292

### Example: Ingredient Addition

The equipment is to add a specified amount of an ingredient.

EM.Cmnd=1 tells the equipment to perform its function.

EM.State=1 to indicate that it is adding material.

EM.State=0 to indicate that it is no longer adding material.

EM.DN=1 to indicate that it is done (has added the requested amount and turned off).

- **Finish, keep running** – If DN = 1 and State = 1. The equipment accomplishes what has been requested but remains running.

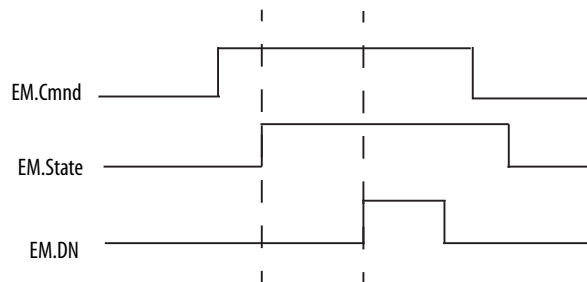

46293

### Example: Simple Agitation

The equipment is to maintain an agitator at a specified speed.

EM.Cmnd=1 tells the equipment to perform its function.

EM.State=1 to indicate that it is running.

EM.DN=1 to indicate that it is done (has attained the desired speed).

User programming for a piece of equipment could change the behavior of the EM.State bit depending on its mode of operation. This provides for the equipment to perform as one in a particular step, but as a different behavior in another step.

Example: Timed Agitator

In one step, it is desirable to use as a free running agitator that is stopped at the end of the step. In another step, it could be used with a timer in the equipment to perform a precision-timed agitation that shuts down and completes when finished. In each case, the programming to set the EM.State is different.

## Operator Phase Control

Users with the proper security can take control of a phase in a runtime environment. Complete these steps.

1. On the Run Time Detail faceplate, click an equipment box to access the Phase Control faceplate.

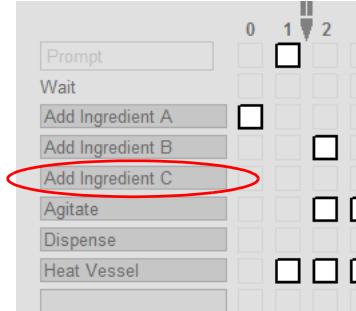

2. Click the Acquire Equipment button to let an authorized user take ownership of the phase.

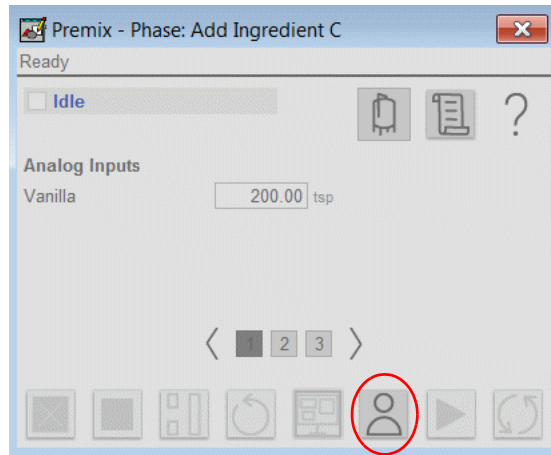

3. To modify an input parameter, click the value field to open the keypad entry display.

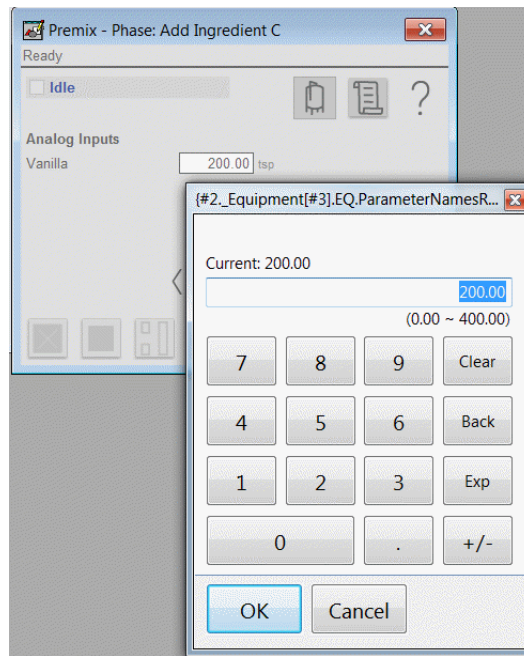

4. Using the keypad, type a new value and click OK.  
The keypad disappears and the new value is entered.
5. To run a phase, click the Start Command button.

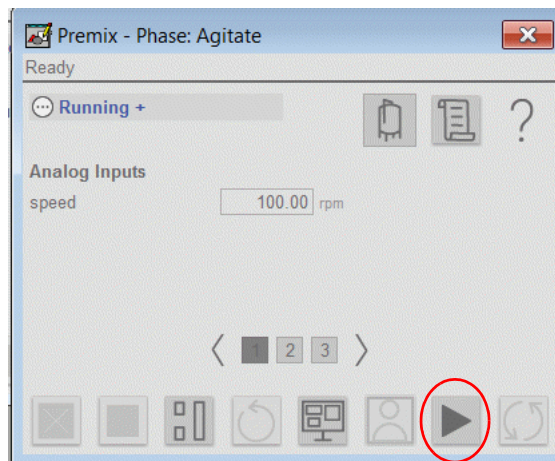

The Output value activates and shows the amount.

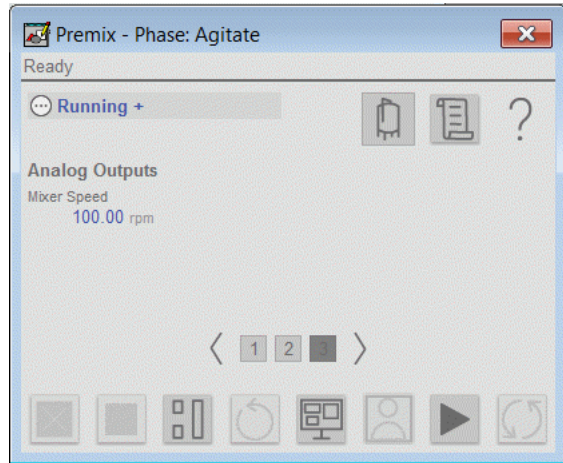

6. When a phase is complete, stopped, or aborted, the Reset Command button  activates to let you reset the phase to the Idle state (which can then be started again).



## Equipment Control

If you have the proper security, complete these steps to take control of equipment.

1. On the Phase Control faceplate, click the icon for the Equipment Run-Time Display.

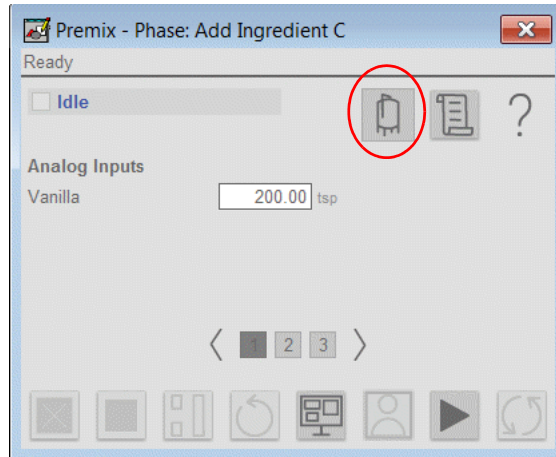

2. Click the Acquire Equipment button.

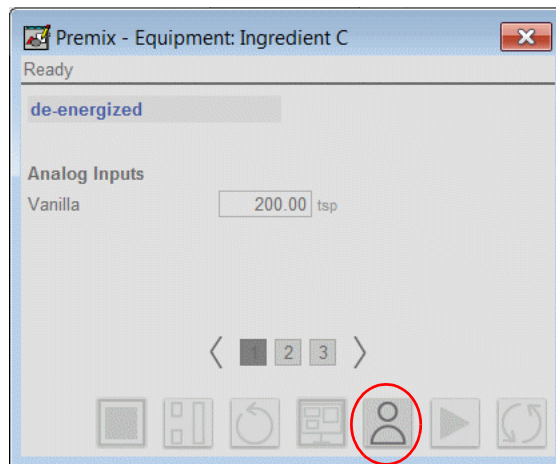

3. With this access you can perform the following actions similar to the Phase Control faceplate:
  - Click the input parameter value field to modify the value
  - Click the Start Command button to run the equipment module
  - Click the Hold button to hold the equipment
  - Click the Reset button to reset the equipment module

## Multi-Step Configuration

The Multi-Step Configuration display provides an alternative means of configuring your recipe with prompts, pauses, and wait timers on one display.

1. On the Manual tab, click the button to edit the currently running sequence.

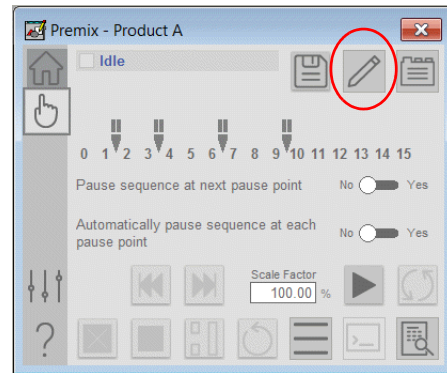

2. Click the Display Multi-Step Config Window button.

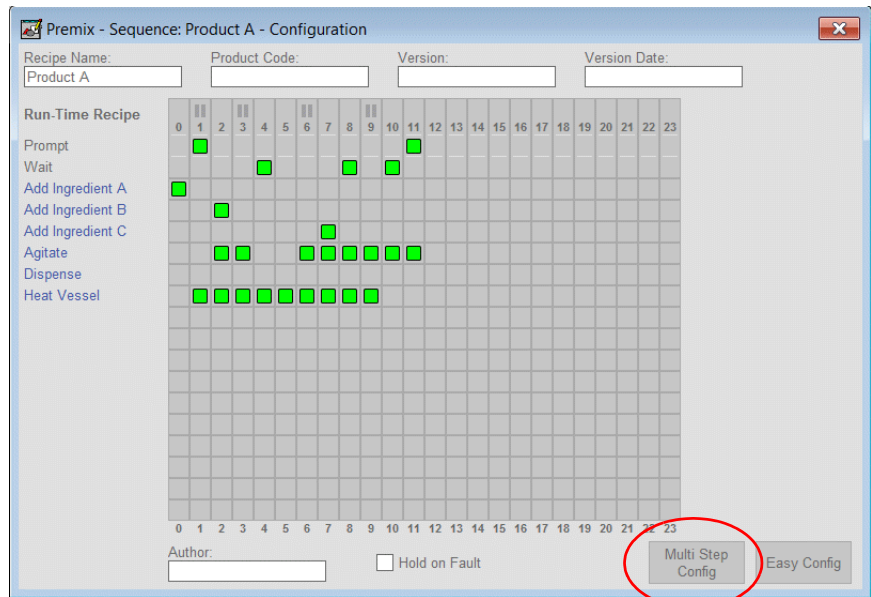



## Easy Recipe Configuration

The Easy Config button on the Recipe Configuration display provides access to a display that lets you create a basic outline of a recipe. When you decide the steps are correct, you can go back and add the specific parameters.

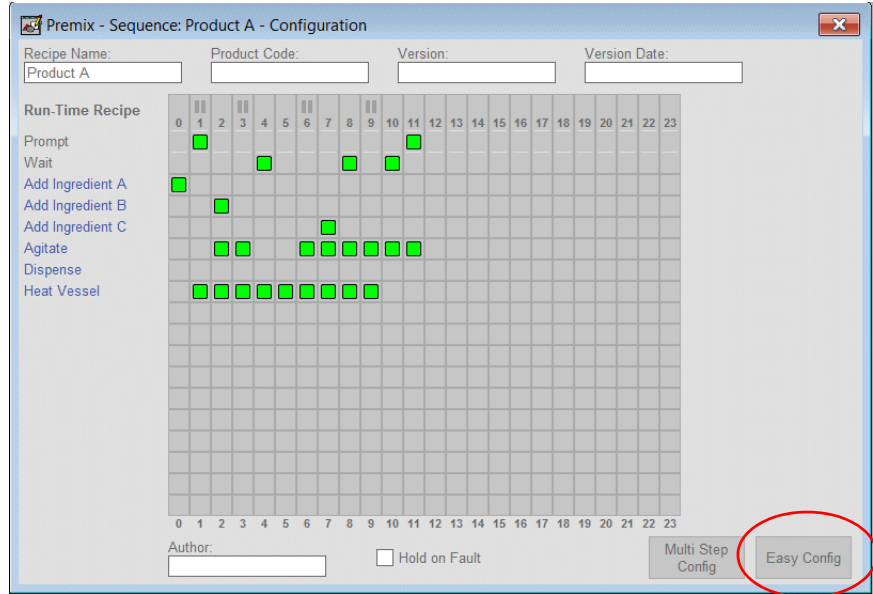

On the grid display, click the phase/step intersection block to toggle the phase between inactive/active for that step, rather than open the phase configuration window.

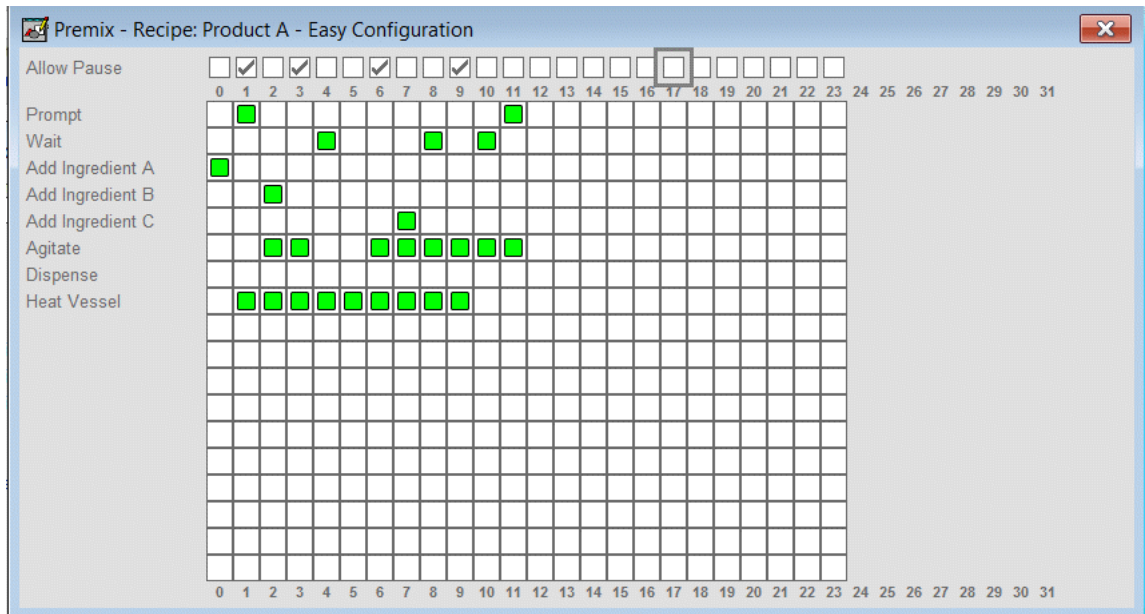

See [page 40](#) for details on configuring phases per step in a sequence.

## Start/Run Batch Demonstration

This section steps through a demonstration of LBSM functionality by using the provided FactoryTalk View HMI components. The demonstration assumes that the installation and configuration steps have been completed, and that a batch has been created. We cover these preliminary steps later in the manual.

The red circle in the illustration indicates that our demonstration, or running a batch in general, occurs after the configuration of several application benchmarks. After the demonstration, we'll walk you through each section (denoted by page number) with the configuration activities that comprise the master recipe.

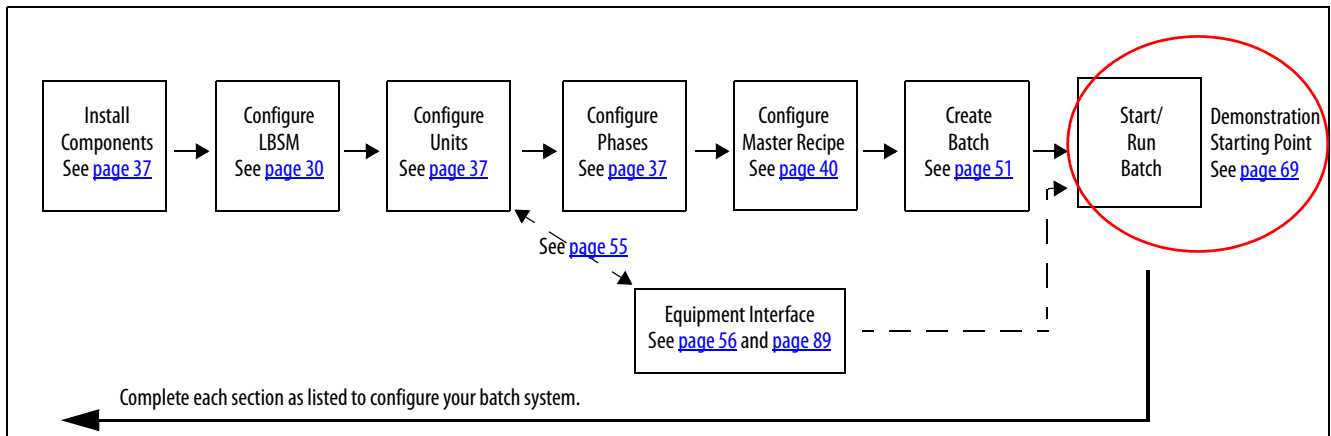

In the LBSM demonstration, we use recipe 'Product A' to add and mix three ingredients to tank 'Premix 1', and then transfer the resulting product from the tank. LBSM lets you break the capabilities of the process into independent process actions, which can include operator interaction via prompts.

Figure 10 - LBSM Unit Example

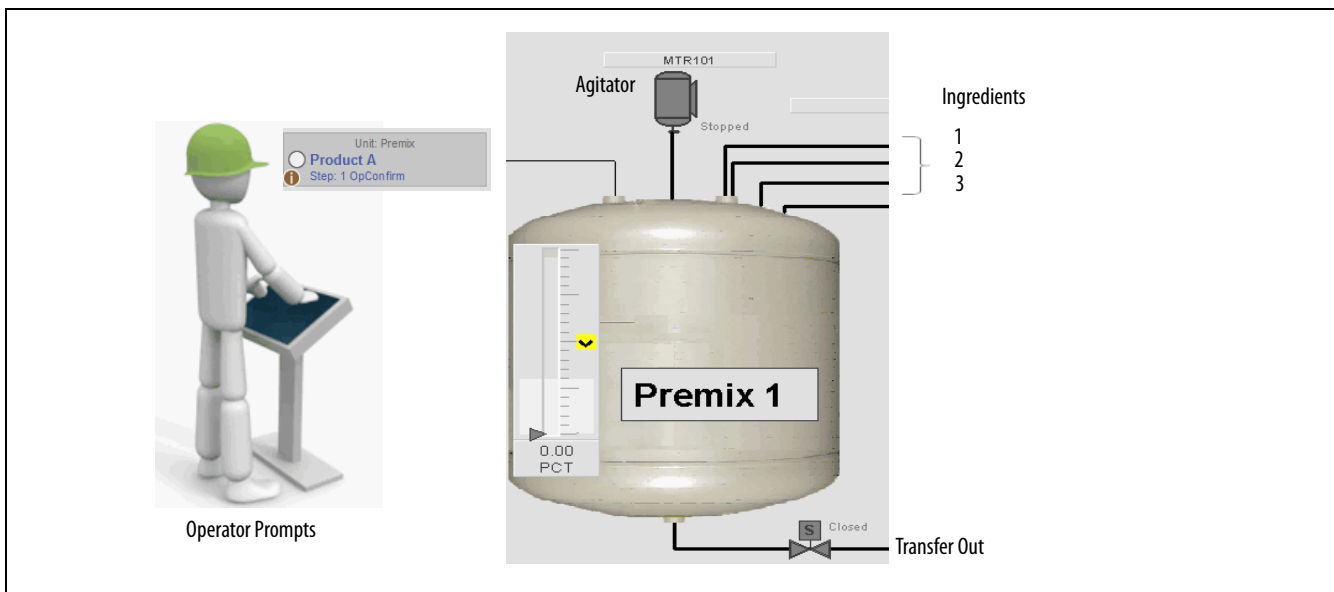

1. Click the main global object to access the Operator tab faceplate.

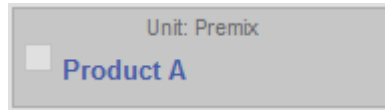

The global object uses text and graphics to summarize the unit.

**IMPORTANT** The main global object is the launch point for LBSM, but it's not intended to be the only link to LBSM. For example, you can place the object on each unit graphic or multiple HMI displays.

**TIP** This demonstration assumes that you have created a batch and entered the batch scale factor.  
See [page 51](#) for procedures on how to create a batch.

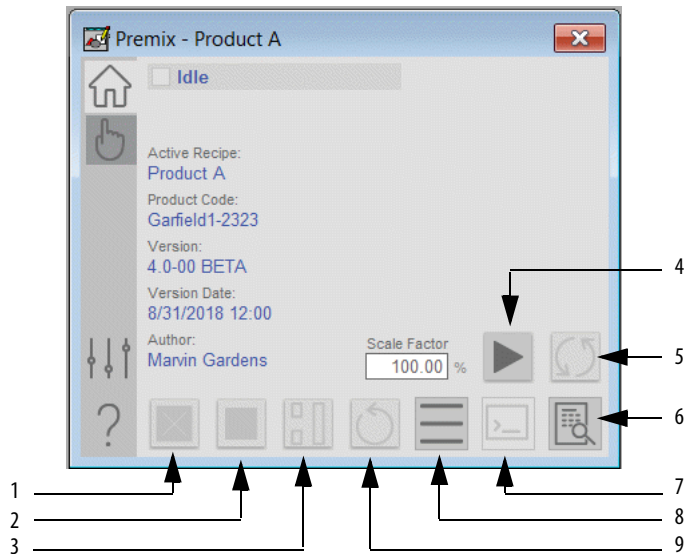

Item	Description
1	Abort sequence
2	Stop sequence
3	Hold sequence
4	Start sequence
5	Reset sequence
6	Access the runtime detail faceplate
7	Respond to Operator prompt
8	Load a sequence from the master sequence list
9	Restart sequence

The same buttons on the Operator tab are also available on the Run Time Detail faceplate. The Run Time Detail faceplate visually arranges the progress of the procedural steps.

## 2. Access the Run Time Detail faceplate.

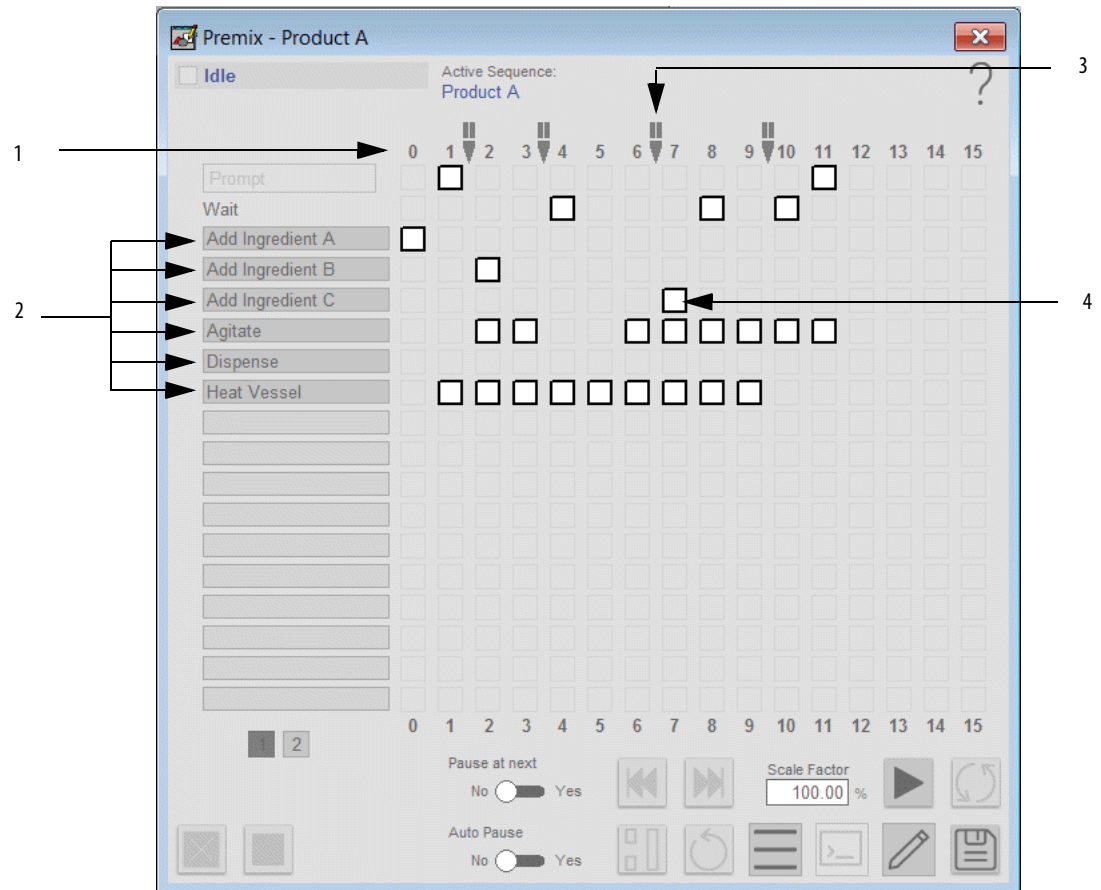

Item	Description
1	Sequence steps
2	Equipment phases
3	Pause point
4	A white box indicates that this phase is configured in this step.

## 3. On the Run Time Detail faceplate, click the Start button.

You can start a batch **only** when it's in the Idle state.

The Start command button, when clicked, transitions the batch to the Running state. Each time a batch starts, the batch or sequence unique ID is incremented.





**Step 1 - Heat Vessel**

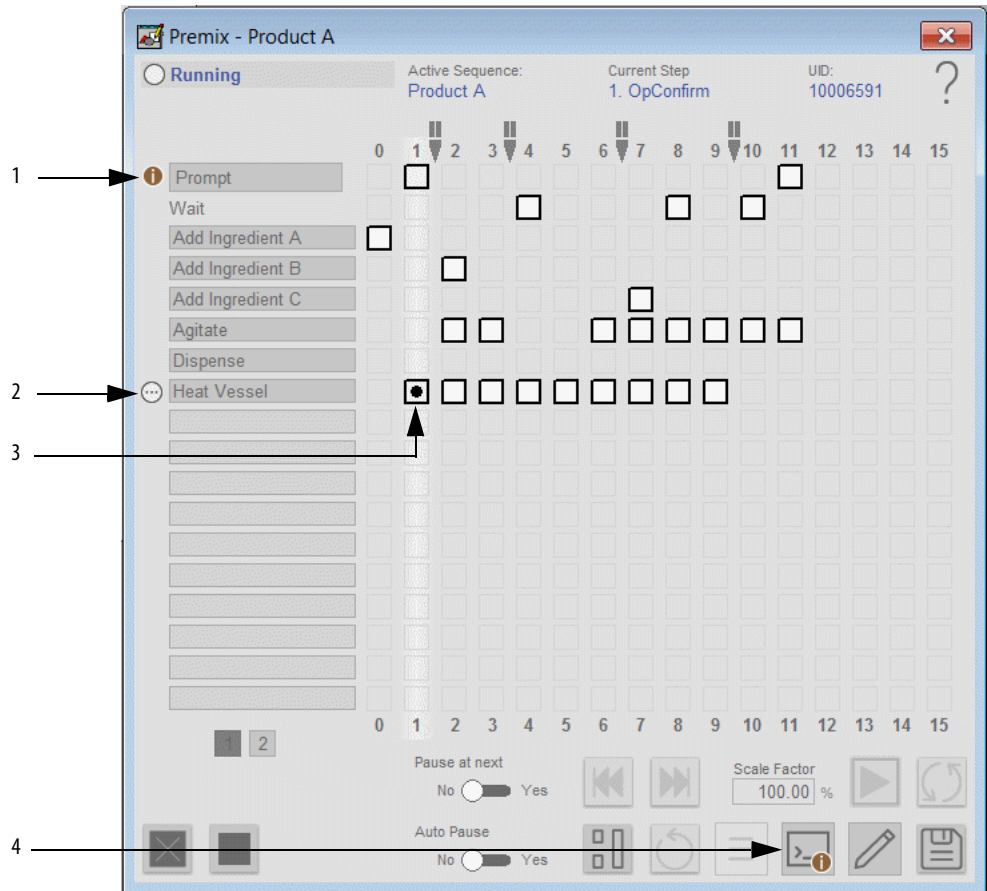

Item	Description
1	Indicator to signify that operator interaction is required
2	Phase State
3	Black dot in the white box indicates that the phase has been completed
4	Indicator to signify that operator interaction is required

### Step 1a - Prompt Acknowledgment

Click either of the indicators for operator interaction to access the prompt acknowledgment display. Type in the response value and press the check mark button to acknowledge the response.

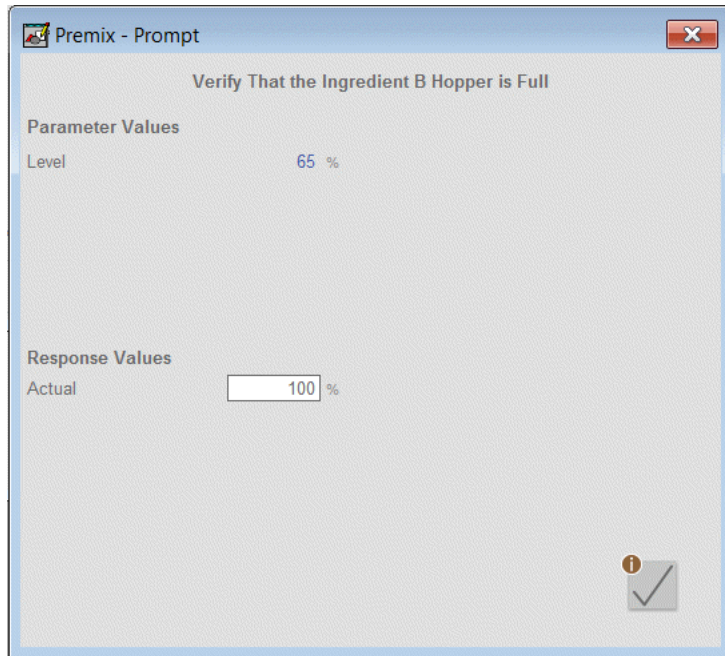

## Step 2 - Material Addition and Agitation

Column turns white to indicate that the current step is in progress.

The black dots indicate that Add Ingredient B and Agitate phases are complete. The step is waiting for the Heating Vessel phase before continuing.

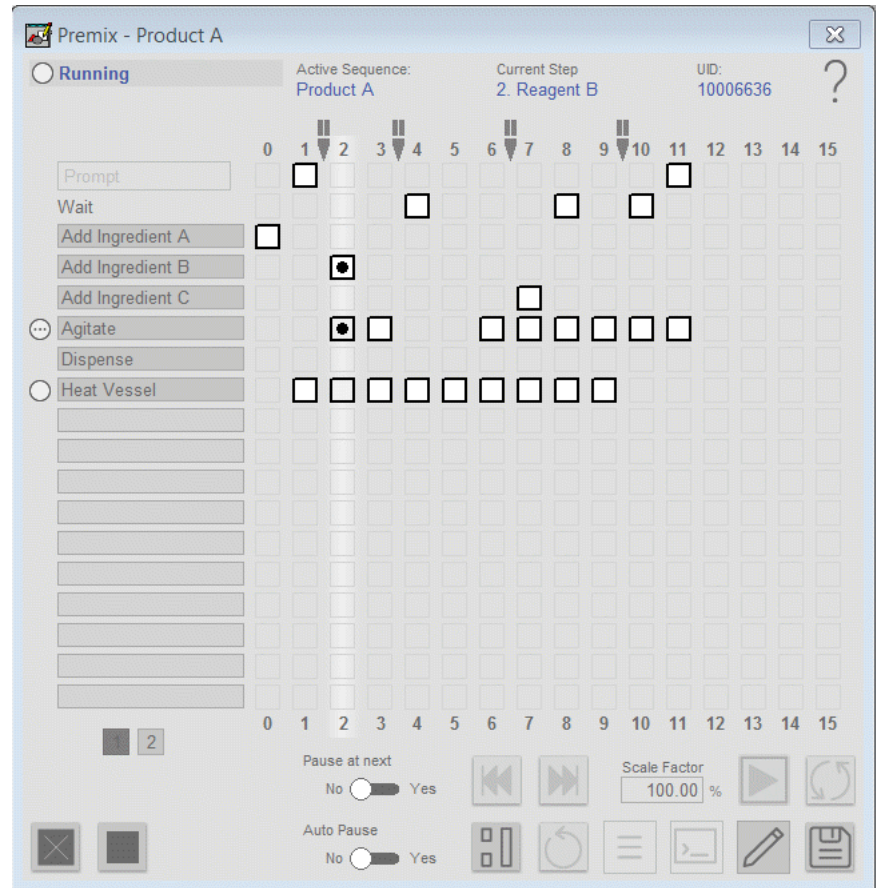

**IMPORTANT** You do not have to stop phase equipment to get to a new setpoint. A 'transfer of control' permits the equipment, such as an agitator or a heating device, to acquire a different setting. In our example, the agitator phase runs across multiple steps, and configured for different recipe speeds if applicable.

### Step 3 - Continue to Agitate

Column turns white to indicate that the current step is in progress.

The black dot indicates that the desired function for that phase is complete. The step is waiting for the Heating Vessel phase before continuing.

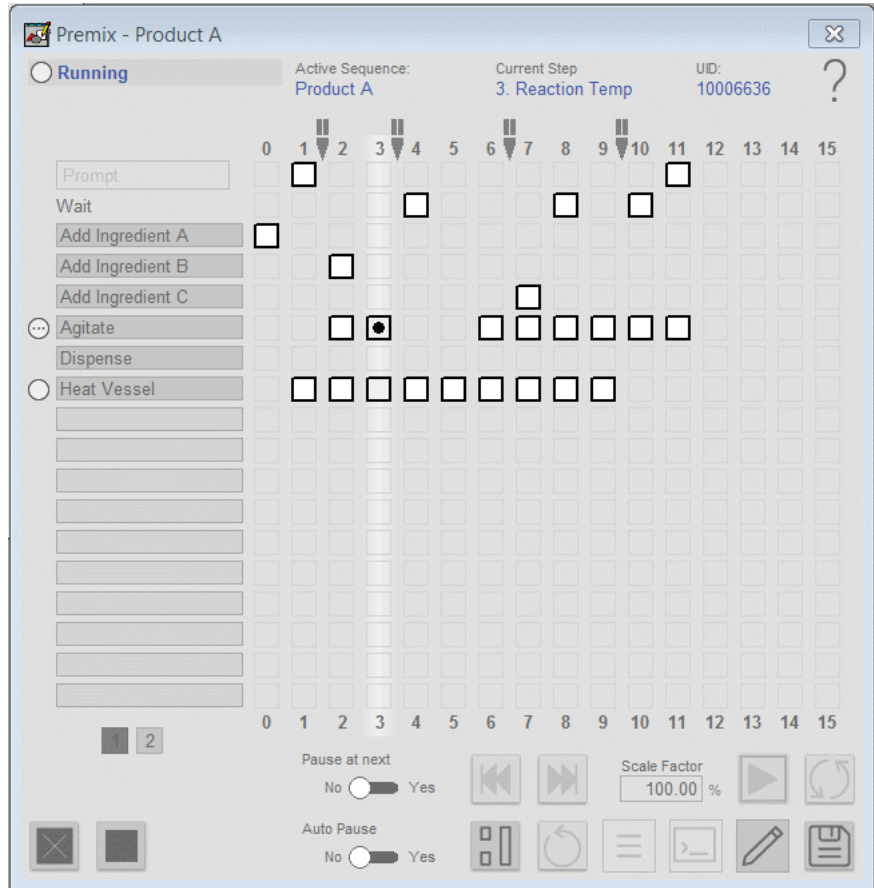



### Step 5 - Continue to Heat Vessel, Hold Functionality

Column turns white to indicate that the current step is in progress.

Column turns brown when a running sequence is Held. All active phases are commanded to their respective hold states. The sequence can then be restarted, stopped, or aborted.

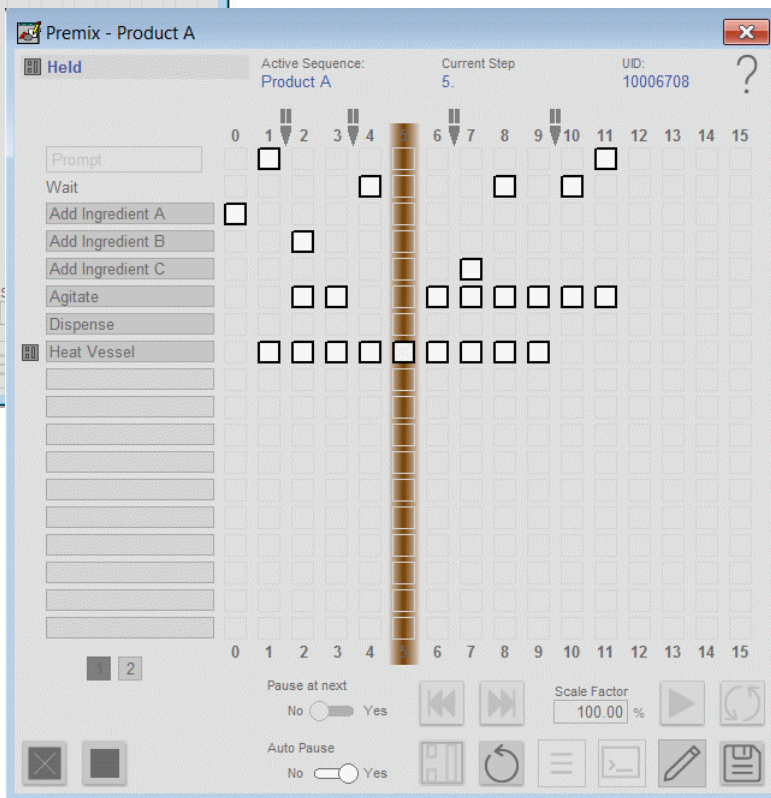
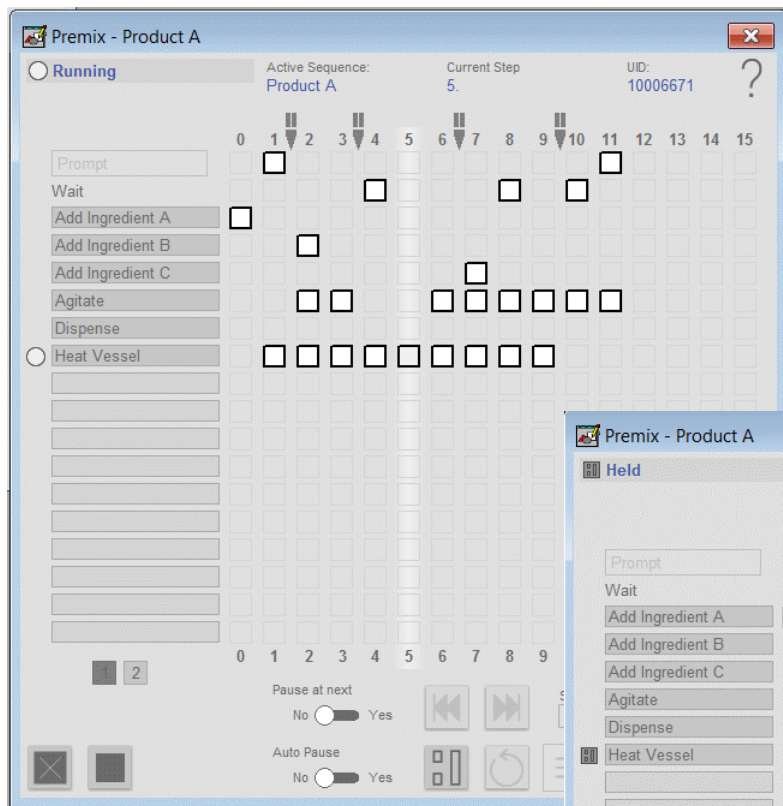

### Step 6 - Agitate, Heat Vessel

Column turns white to indicate that the current step is in progress.

The black dot indicates that the desired function for that phase is complete.

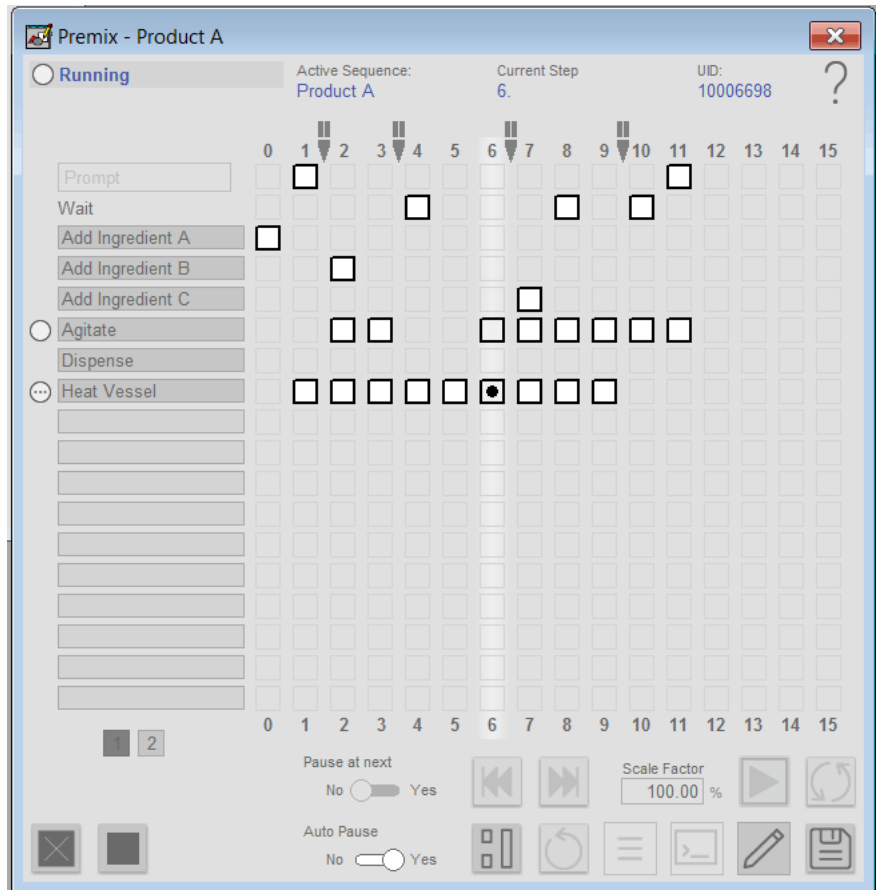

### Step 7 - Ingredient C Addition, Continue Agitation and Heating

Column turns white to indicate that the current step is in progress.

The black dot indicates that the desired function for that phase is complete.

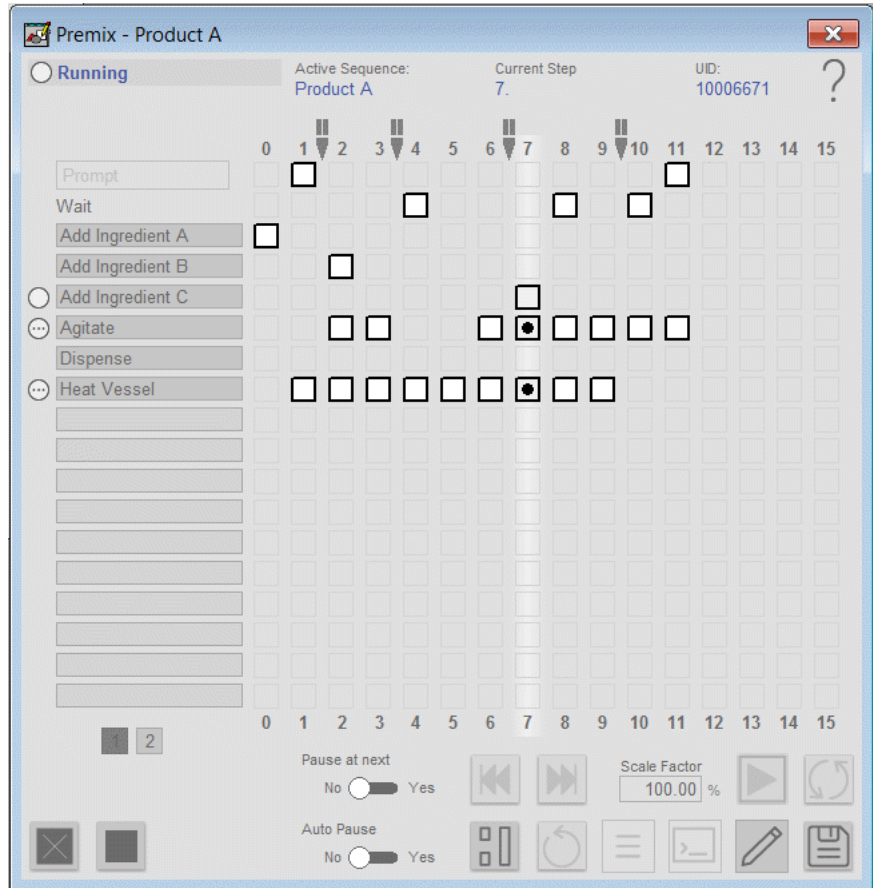



### Step 8 - Continue Agitation and Heating Vessel, Wait Timer

Column turns white to indicate that the current step is in progress.

The wait timer starts timing when the step becomes active. The timer counts down from the preset value. The remaining wait time is displayed in seconds.

The black dot indicates that the desired function for that phase is complete.

The screenshot displays the LBSM interface for 'Premix - Product A'. The 'Active Sequence' is 'Product A' and the 'Current Step' is '8. Whipl'. The 'UID' is '10006671'. The interface shows a sequence of steps from 0 to 15. The current step, 8, is highlighted in white. A black dot is visible in the 'Agitate' row at step 8, indicating completion. The 'Wait' timer is set to 6.90 seconds. The 'Heat Vessel' step is also active, with a black dot at step 8. The interface includes a 'Prompt' field, a 'Scale Factor' of 100.00%, and various control buttons like 'Pause at next' and 'Auto Pause'.

### Step 9 - Continue Agitation and Heating Vessel

Column turns white to indicate that the current step is in progress.

The black dot indicates that the desired function for that phase is complete.

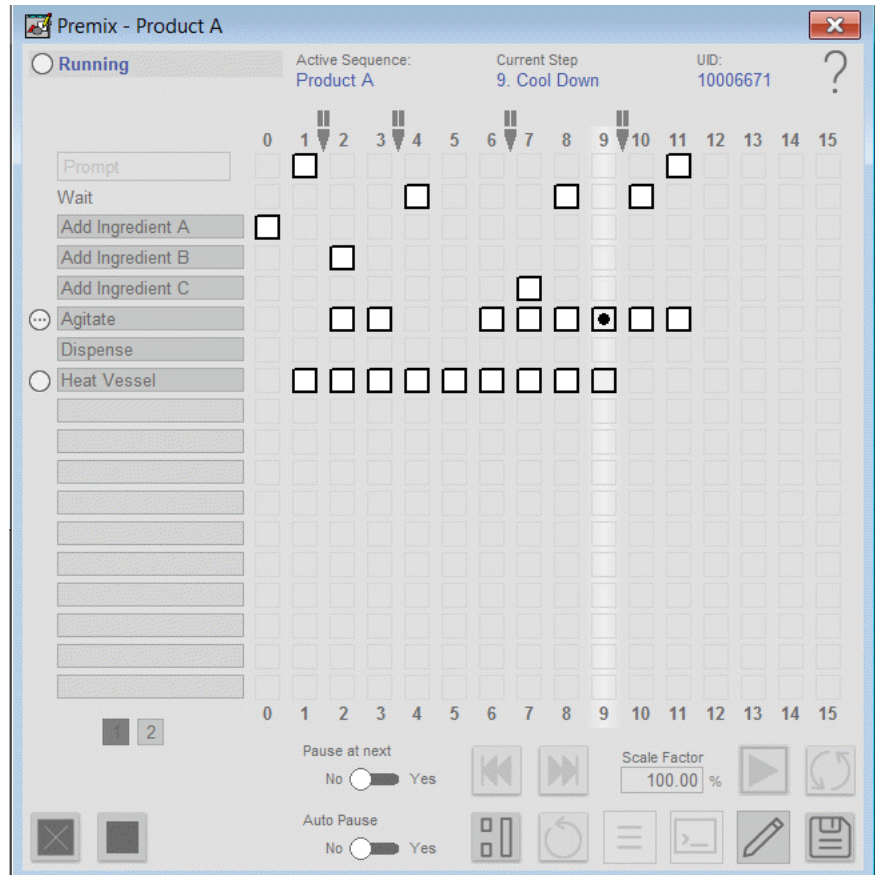

### Step 10 - Continue Agitation, Wait Timer

Column turns white to indicate that the current step is in progress.

The wait timer starts timing when the step becomes active. The timer counts down from the preset value. The remaining wait time is displayed in seconds.

The black dot indicates that the desired function for that phase is complete.

The screenshot displays the LBSM interface for 'Premix - Product A'. The 'Running' status is selected. The 'Active Sequence' is 'Product A' and the 'Current Step' is '10'. The 'UID' is '10006671'. The interface shows a sequence of steps from 0 to 15. Step 10 is currently active, indicated by a white column and a black dot. The 'Agitate' function is active during step 10. The 'Wait' timer is set to 10.10 seconds. The 'Scale Factor' is 100.00%. The 'Pause at next' and 'Auto Pause' options are both set to 'No'.



### Batch Complete

Status box indicates that the procedure is 'Complete'.

Boxes are cleared for another batch.

The reset button is active. The state can be reset to Idle. The batch state must be in Idle before a new batch can be started.

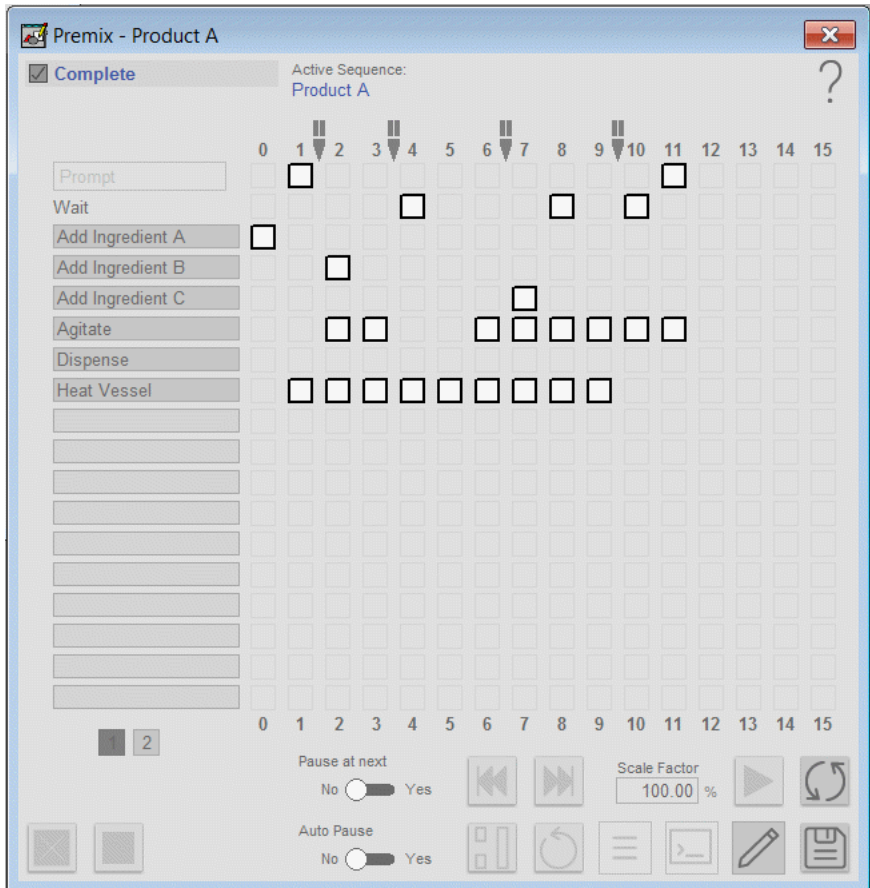

## LBSM Help Displays

Press the help button  on the faceplates to access help specific to that faceplate.

The help file is in .pdf format and opens in a separate window.











### Help Display

#### LBSM Faceplate Help



**Status Indicators**

-  A condition requires attention



**Sequence States**

<input type="checkbox"/> Idle	 Stopping
 Running	 Stopped
 Continuing	 Complete
 Holding	 Aborting
 Held	 Aborted
 Restarting	 Resetting









**Input Qualification Indicators**

-  Phase has achieved parameters for step.
-  Phase has not yet achieved parameters for step.

**Sequence Symbols**

 Configured Pause point. Sequence will pause at this point if the "Pause" button is pressed.	 The sequence is currently paused at this point. Press the "Resume" button to continue
---	---

**Commands**

 Start Command	 Stop Command. Reform an orderly shutdown of running sequence
 Resume Command	 Abort Command. Immediate shutdown of running sequence
 Reset Command	 Restart Command
 Hold Command	 Previous Pause Point. Move the current step pointer to the previous pause position.
 Next Pause Point. Move the current step pointer to the next pause position.	

## Advanced Capabilities

This appendix describes additional phase configurations that extend the LBSM application for advanced situations. These features are performed behind-the-scenes of visual clues.

Within the LBSM unit step array, there are configuration options that are not represented on the HMI faceplates and displays. These options are PIContinue, PIOwned, and PImmRel (immediate release). Each of these features is a DINT, where each bit in the DINT is mapped to its respective, numbered phase (or PI).

Name	Data Type
[-] _LBSMUnit[0]_SQrt.Config.Step	LBSM_SQ_St..
[-] _LBSMUnit[0]_SQrt.Config.Step[0]	LBSM_SQ_St..
[+] _LBSMUnit[0]_SQrt.Config.Step[0].Name	String_16
[-] _LBSMUnit[0]_SQrt.Config.Step[0].PauseableStep	BOOL
[-] _LBSMUnit[0]_SQrt.Config.Step[0].PromptStep	BOOL
[-] _LBSMUnit[0]_SQrt.Config.Step[0].WaitPhaseStep	BOOL
[-] _LBSMUnit[0]_SQrt.Config.Step[0].ResetAccOnHold	BOOL
[-] _LBSMUnit[0]_SQrt.Config.Step[0].StepTORResetOn...	BOOL
[+] _LBSMUnit[0]_SQrt.Config.Step[0].StepTOPre	DINT
[+] _LBSMUnit[0]_SQrt.Config.Step[0].WaitPhasePre	DINT
[+] _LBSMUnit[0]_SQrt.Config.Step[0].PromptRef	DINT
[+] _LBSMUnit[0]_SQrt.Config.Step[0].PIs	DINT
[+] _LBSMUnit[0]_SQrt.Config.Step[0].PIOwned	DINT
[+] _LBSMUnit[0]_SQrt.Config.Step[0].PImmRel	DINT
[+] _LBSMUnit[0]_SQrt.Config.Step[0].PIContinue	DINT

### PIContinue

When a bit is set for this option, the step does not wait for the corresponding phase (PI) to complete before a transition to the next step. All other conditions must be met, such as other phases finishing.

This feature is useful when a phase is used across multiple, contiguous steps and it does not require that phase to be done in the intervening steps. This option is similar to a parallel branch in an SFC; one branch has one phase and the other branch has multiple phases (sequentially) but they converge.

Caution, however, must be exercised when you use this configuration. There are no visual cues or indications that this option is active in the HMI.

For example, a Pause Point is configured at one of the steps where a PIContinue is configured and the Pause is used. The step is still allowed to move between Pause Points and resume execution. Upon resuming execution, the sequence is still waiting for the phase to complete from the Continue. There is no visual clue on the HMI that the Continue is occurring and gives an impression the sequence is 'hung.'

### PIOwned

This option was originally implemented to allow ownership of equipment in steps before its actual use to make sure that the equipment was available. This bit has no value today because equipment ownership is implied by unit in LBSM.

### PIImmRel (immediate release)

When a bit is set in this option, the corresponding phase (PI) is reset and released immediately upon completion of the equipment task (done and de-energized). The release does not wait until the end of the step. Critical equipment, which is shared between units, is released as soon as it finishes so that it is available for use by another unit.

### Manual Generation of Batch ID

This feature provides an option to disable automatic batch ID generation and let a user externally generate their own identifier. Users who choose to exercise this option must be careful to make sure of batch ID uniqueness.

To enable/disable the batch ID generation, use the 'Cfg\_UID' tag in the SQ Program Tags.

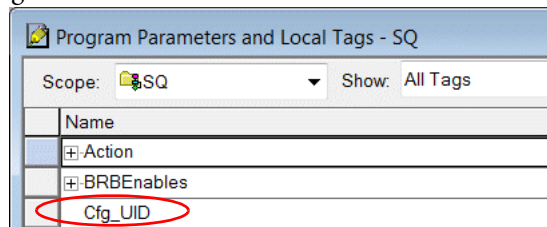

By default this tag is set to '0' and automatic batch ID generation is enabled. If you set this bit to '1', you can manually generate batch ID.

You can set your own batch ID value by writing to the LBSMUnit[x].UID tag.

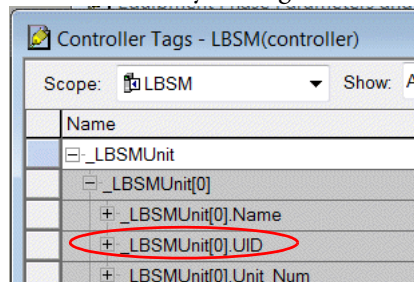



## Equipment Interface Codes

### Equipment Interface Codes

The EM\_Composite member of the \_Equipment array provides the interface between the LBSM application and your equipment. Your equipment module code must be configured to interface to these tags.

---

**IMPORTANT** Details for each member of the EM\_Composite data type are shown in [Table 9](#).  
Examples for programming the interface are shown in Appendix C on [page 91](#).

---

**Table 9 - EM\_Composite Data Types**

Member	Data Type	Description
EquipmentName	String_16	Equipment name that is displayed on the HMI.
Display	String_16	For future enhancement.
EMProgReq	BOOL	Boolean input that requests the Equipment Module use Program mode. This input is used by the EM Add-On Instruction.
EMProgLReq	BOOL	Latched version of the EMProgReq
EMOperReq	BOOL	Boolean input that requests the Equipment Module use Operator mode. This input is used by the EM Add-On Instruction.
EMOperLReq	BOOL	Latched version of the EMOperReq
CMReq	BOOL	Boolean input that requests the CMs use Operator mode. This input is used by the EM Add-On Instruction.
Cmnd	BOOL	Boolean input that commands the EM to perform its primary function.
ParameterEnable	DINT	Enabling a parameter makes it active for the equipment module. This action corresponds to EM enable on the Equipment Configuration dialog box.
ParameterNamesReal	LBSM_ParameterReal[4]	Names of the Real parameters for display on the HMI equipment.
ParameterNamesBool	LBSM_ParameterBool[4]	Names of the Boolean parameters for display on the HMI equipment.
ParameterValues	LBSM_ParameterValues	Inputs to the EM that can be modified from the HMI. For example, setpoints.
ActualEnable	DINT	Enabling an actual value (or report value) makes it active for the equipment module. This corresponds to EM enable on the Equipment Configuration dialog box.
ActualNamesReal	LBSM_ParameterReal[4]	Names of the values reported to the phases for display on the HMI equipment.
HoldReq	BOOL	Boolean input that requests the EM to perform its Hold function. This could be to go to a known state or stay where it is (or do nothing).
ResetReq	BOOL	Boolean input that requests the EM to reset; put the EM into a known initial state, ready to run again.
NewParmsONS	BOOL	Set by a supervisory entity when new parameters are given to the EM. <b>User program must always reset this tag (set to zero).</b> <b>IMPORTANT:</b> Used as a handshake for upper level supervisors (so they know the EM executed).

**Table 9 - EM\_Composite Data Types**

Member	Data Type	Description
EMProg	BOOL	Boolean output that indicates the EM is in Program mode. <b>IMPORTANT:</b> The EMProgReq/EMProg interaction is used by the Running routine of the phase to determine the appropriate EM access mode for operation.
EMProgL	BOOL	Latched version of the EMProg
EMOper	BOOL	Boolean output that indicates the EM is in Operator mode. <b>IMPORTANT:</b> The EMOperReq/EMOper interaction is used by the Running routine of the phase to determine the appropriate EM access mode for operation.
EMOperL	BOOL	Latched version of the EMOper
EM	BOOL	Boolean output that indicates the EM is in the EM mode.
CM	BOOL	Boolean output that indicates the EM is in the CM mode.
State	BOOL	Boolean output that indicates that the EM is Off (0) or On (1). Indicates that the EM is performing its primary function as in response to a Cmnd = 1. <b>IMPORTANT:</b> Used by the Stopping routine in the phase to determine when the EM is in the user-definable Off or On state.
DN	BOOL	Boolean output indicates that the EM has achieved its final state. <b>User program must always set this tag</b> at some point in the operation of the EM. Every EM has a condition or state that is considered its final condition or state. You must define that condition for an individual EM and appropriately condition the DN bit. EMs that 'Run until Done' set the DN bit when its objective is achieved. For example, 'automatically metered ingredient add'. EMs that 'Run until Stop' set the DN bit immediately or constantly. For example, 'agitator'. EMs that 'Run until Done, Continue until Stop' set the DN bit when its objective is achieved. For example, 'Slow reacting temperature loop' (it is 'DN' when at SP but continues to regulate until told to stop). The DN must be reset whenever the Cmnd bit is low. The DN can go low as the result of receiving new parameters that indicate a new objective, as defined by user logic. <b>IMPORTANT:</b> The Cmnd/DN interaction tells a phase that the EM has performed the requested action. The phase sets the Cmnd and waits to see a DN to know that the EM has performed the requested action.
Actual	LBSM_ActualValues	Outputs from the EM that are used by the phase. For example, a control variable, such as temperature or speed.
ResetDN	BOOL	Boolean output that indicates that the EM has been reset. The ResetDN is reset whenever the ResetReq is low. <b>IMPORTANT:</b> The ResetReq/ResetDN interaction is used by the Resetting routine of the phase to determine that the EM has been reset.
Held	BOOL	Boolean output that indicates that the EM is in a state that is caused by the setting of the HoldReq input. Held is reset whenever HoldReq is low and the EM has resumed normal operation. <b>IMPORTANT:</b> The HoldReq/Held interaction is used by the Holding and Restarting routines of the phase to determine that the EM is in the correct states.
Fault	BOOL	Indicates an EM fault. Could be the OR'ed composite of all EM component faults.
LEMFault	BOOL	Latched version of the Fault
Health	BOOL	Indicates bad EM health. Could be the OR'ed composite of all EM component health bits (like CM I/O health bits).
Exists	BOOL	Bit that is set if the controller has code that uses this EM interface and is executing.
MyIndex	DINT	Set automatically by the LBSM code.
MyUnit	DINT	Set automatically by the LBSM code.
AcquisitionTO	FBD_TIMER	This timer, which starts when ownership of the EM is requested, is used for acquiring ownership of the EM. If ownership is not confirmed within this amount of time, a fault is issued.
CmndTO	FBD_TIMER	This timer, which starts when the command is issued, is used for completion of a command. If the command is not completed within this amount of time, a fault is issued.

---

## Bit Interface Examples

The following examples illustrate the basic usage of the bit interface if you are **not** using PhaseManager™ software.

### 'Add Ingredient' Example

An ingredient addition function can be comprised of one valve or the combination of a pump, valve, and totalizer. Either way, you must define these functions:

- How much ingredient to add (ParameterValue)
- When to go (Cmnd=1)
- When to temporarily suspend its operation, if needed (HoldReq = 1)
- When to stop (Cmnd = 0)
- When to reset any persistent functionality (ResetReq = 1)

You need to monitor these activities:

- The group is actively functioning or energized (State)
- The group accomplishes what you requested (DN)
- How much ingredient it actually adds (ActualValue)
- When it achieves a temporary suspension of activity (Held)
- When it resets its internal functions (ResetDn)
- Whether any device faults occur (Fault)

## Run Until Done Example

This example uses a timer as the equipment.

The functionality of this piece of equipment is what is required of any equipment that runs and finishes on its own (and 'Complete' a commanding phase). Usually this type of equipment is used in one step and its functionality does not span contiguous steps, although it can span contiguous steps in non-continuous operation.

This type of equipment must be reset before running again. 'Ingredient Add' is an example of this type of equipment.

**Table 10 - Run Until Done Specification Example**

Specification	Description
Input	Time in milliseconds to run (timer.PRE).
Output	Accumulated time (timer.ACC).
Runtime functionality	When the Cmnd bit is set, run the timer. Set the State bit while the timer is running (timer.ACC = 1). Set the DN bit when the timer is done (timer.DN = 1).
Hold functionality	When the HoldReq bit is set, hold the timer where it is and set the Held bit.
Reset functionality	When the ResetReq bit is set, reset the timer (and set the ResetDN.bit).
NewParms functionality	Not used because the intent of this equipment functionality is to run once and complete (requiring a reset and another start to run again).

### Function Block

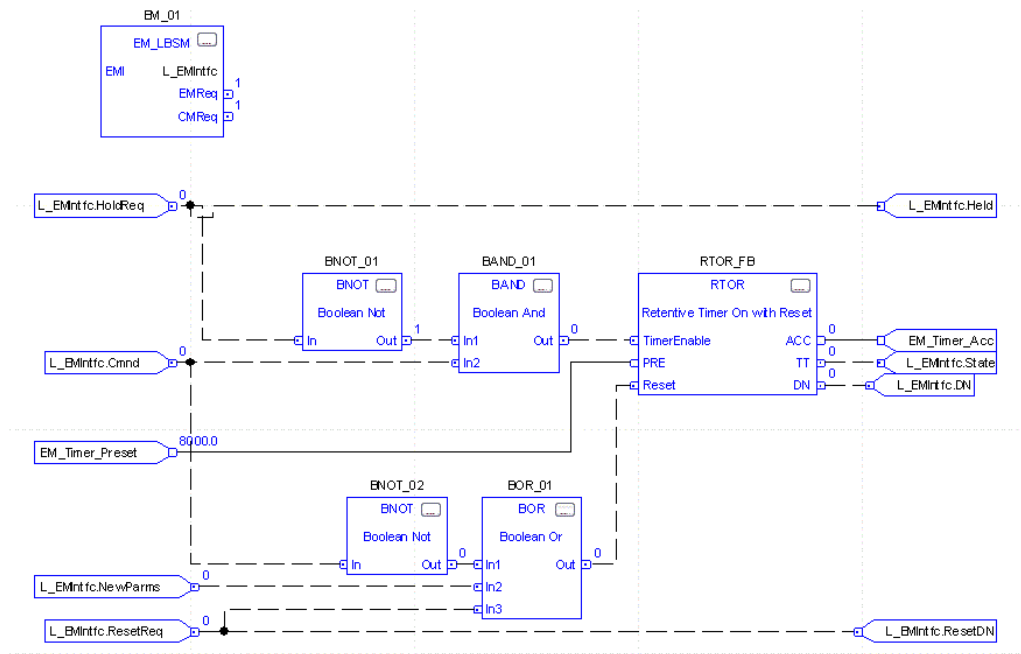

### Ladder Logic

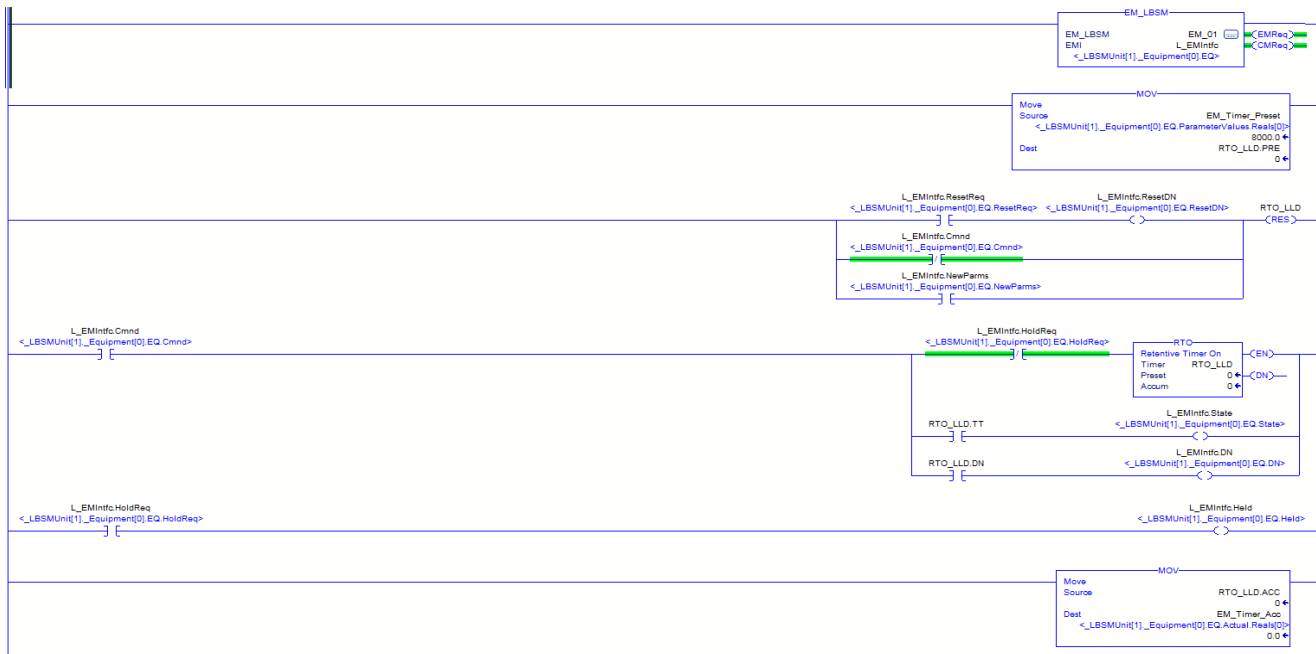

### Structured Text

```

EM_LBSM(EM_01, L_EMIntfc );

RTOR_ST.PRE := EM_Timer_Preset;

L_EMIntfc.ResetDN:= L_EMIntfc.ResetReq;

RTOR_ST.Reset:= L_EMIntfc.ResetReq OR NOT(L_EMIntfc.Cmnd) OR L_EMIntfc.NewParms;

RTOR_ST.TimerEnable:= L_EMIntfc.Cmnd AND NOT(L_EMIntfc.HoldReq) ;

RTOR(RTOR_ST) ;

L_EMIntfc.State:= RTOR_ST.TT AND L_EMIntfc.Cmnd;

L_EMIntfc.DN:= RTOR_ST.DN AND L_EMIntfc.Cmnd;

L_EMIntfc.Held:= L_EMIntfc.HoldReq;

EM_Timer_Acc:=RTOR_ST.ACC;
    
```

## Run Until Stopped Example

This example uses a timer as the equipment.

The functionality of this piece of equipment is what is required of any equipment that runs and continues until commanded to stop (and not 'Complete' the phase). This type of equipment can be used in one or more steps and its functionality can span contiguous steps in an uninterrupted fashion.

This type of equipment does not need to be reset before running again. Examples of this type of equipment include Continuous Agitation and Temperature Control.

**Table 11 - Run Until Stopped Specification Example**

Specification	Description
Input	Time in milliseconds to qualify as DN (timer.PRE).
Output	Accumulated time (timer.ACC).
Runtime functionality	When the Cmnd bit is set, run the timer. Set the State bit while the Cmnd bit is set. Set the DN bit when the timer is done (timer.DN = 1).
Hold functionality	When the HoldReq bit is set, hold the timer where it is if it has not yet completed (and set the Held bit).
Reset functionality	When the ResetReq bit is set, reset the timer (and set the ResetDN.bit).
NewParms functionality	When the NewParms bit is set, the timer is to be reset. During the course of automatic control with a phase, this type of equipment could be given new parameters in another step without stopping. NewParms instructs the equipment that it has new parameters and must accommodate them. It is possible that the equipment can respond to the new parameters instantly. If so, the NewParms bit is not needed.

### Function Block

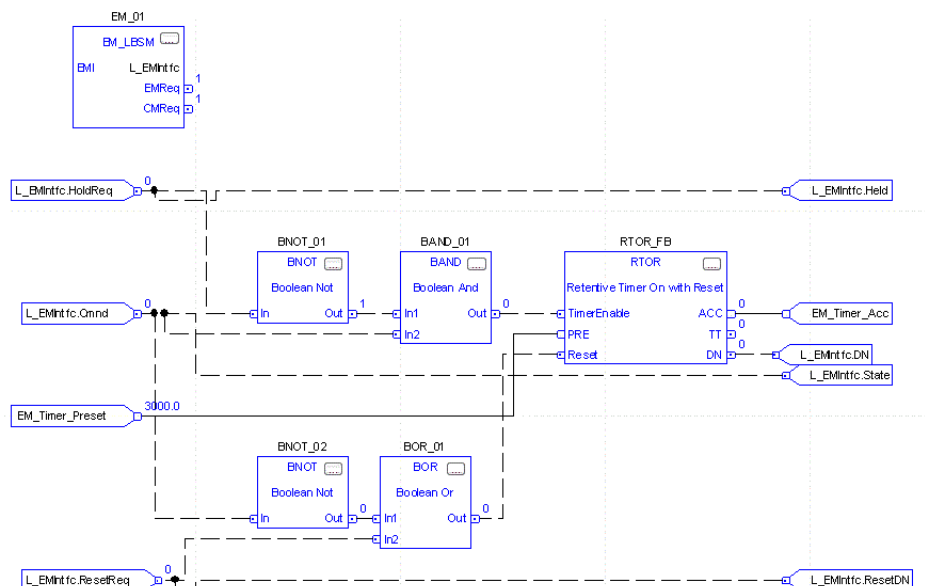



## Run Until Done, Continue Until Stopped Example

This example uses a timer as the equipment.

The functionality of this piece of equipment is what is required of any equipment that executes as either of the previous two, selected by a parameter. This type of equipment can be used in one or more steps and its functionality can span multiple contiguous steps in an uninterrupted fashion.

This type of equipment could need to be reset before running again. Examples of this type of equipment include Timed/Free Agitation.

**Table 12 - Run Until Done, Continue Until Stopped Specification Example**

Specification	Description
Input	Time in milliseconds to qualify as DN (timer.PRE). The mode (0 - Timed, 1 - Free Running).
Output	Accumulated time (timer.ACC).
Runtime functionality	When the Cmnd bit is set, run the timer. Set the State bit while the Cmnd bit is set. Set the DN bit when the timer is done (timer.DN = 1).
Hold functionality	When the HoldReq bit is set, hold the timer where it is if it has not yet completed (and set the Held bit).
Reset functionality	When the ResetReq bit is set, reset the timer (and set the ResetDN.bit).
NewParms functionality	This is not used because the intent of this equipment functionality is to run once and complete (requiring a reset and another start to run again). When the NewParms bit is set, the timer is to be reset. During the course of automatic control with a phase, this type of equipment could be given new parameters in another step without stopping. NewParms instructs the equipment that it has new parameters and must accommodate them. It is possible that the equipment can respond to the new parameters instantly. If so, the NewParms bit is not needed.

### Function Block

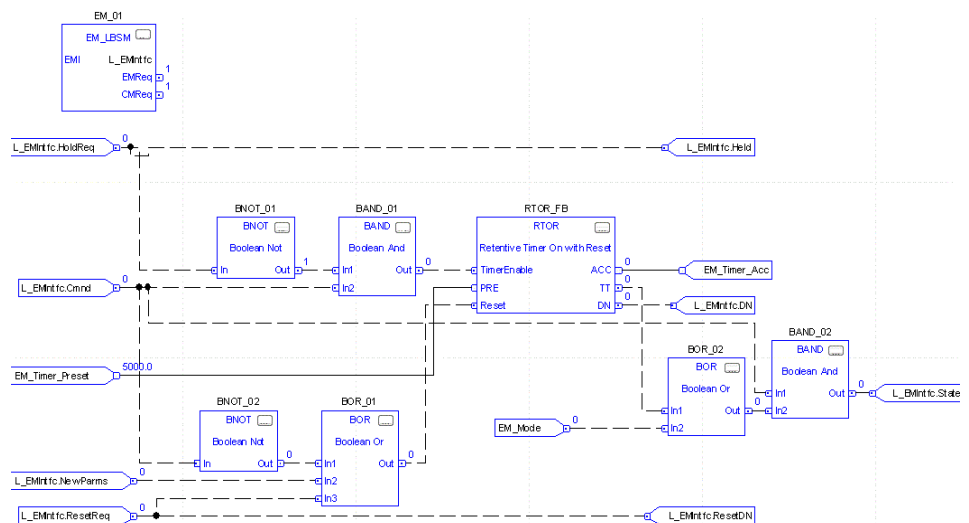





## Notes:

## LBSM Reporting

The LBSM application has tag structures that support the development of a reporting solution.

---

**IMPORTANT** Rockwell Automation® provides a Microsoft Windows service, called the Event Queue Processor. The service performs the extraction and output of the reporting parameters. This application is available as an optional download to the LBSM application.

---

### LBSM Report Data Structure

The LBSM report data structure consists of elements that are shown in the table.

Data Element	Data Field	Description
Time stamp		7 DINT time stamp of RSLogix 5000® controller format
Type		'LBSM'
Data	A set of fields that consist of the following:	
	Unique ID	An integer number that is incremented in the controller to indicate the run number for that unit
	Owner	Operator or recipe name
	Phase	Phase name, if applicable
	Action	State, Input, Output, Prompt, Timer, Step, Paused, Resumed
	Event	State name, if applicable
	Parameter Name	Name of the parameter that is being referenced, if applicable
	Parameter Value	Value of the parameter that is being referenced, if applicable
	Parameter EU	Engineering units of the parameter that is being referenced, if applicable
	Count	Specific count of actions, if applicable
	Unit	Name of the unit

### Retrieve Records

There are two handshake mechanisms available for you to control record removal:

- Boolean
- Integer

All tags exist within the `_LBSMJJournalCntl` controller scoped tag.

## Boolean Mechanism

The Boolean handshake is a two-bit handshake:

- a. The Add-On Instruction sets `Sts_ReadyBOOL` when a record is available for you to read. You then read the record in the `_LBSMJJournalCntl.Record` data field.
- b. You set `Inp_ConfirmBOOL` to instruct the Add-On Instruction that the record is received. The Add-On Instruction clears the `Sts_bit`.

## Integer Mechanism

In situations where the retrieval process is asynchronous, such as via OPC, the Boolean mechanism can be unacceptable. You could miss the low interval of the `Sts_bit` between records.

The DINT mechanism is used for these scenarios.

- a. The Add-On Instruction increments the `Sts_ReadyDINT` (and sets `Sts_ReadyBOOL`) when a record is available for you to read. You then read the record in the `_LBSMJJournalCntl.Record` data field.
- b. You set the value of `Inp_ConfirmDINT` to the value of `Sts_ReadyDINT` to instruct the Add-On Instruction that the record is received.
- c. The Add-On Instruction then sets the value of `Sts_ConfirmDINT_Echo` to echo back your confirmation.

The three-value exchange makes sure that the handshake is involved with either mechanism.

## Log on Demand

This journal functionality lets you log real-time values at any point of the phase. The Report Phase Output Parameters button places values, such as temperature or volume, immediately into a journal entry.

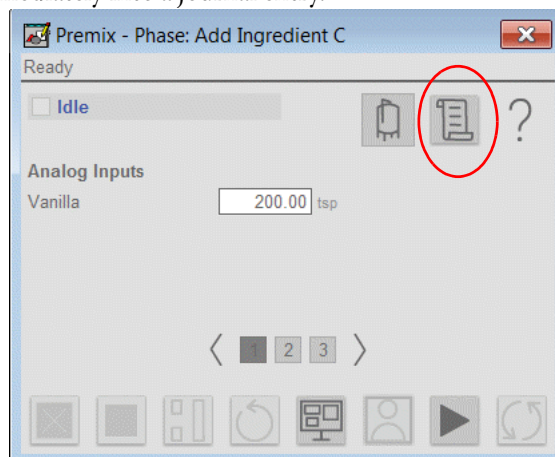

## HMI Security Codes

### HMI Security Codes

FactoryTalk® View software security codes help protect information that is contained within the HMI faceplates. Operators, maintenance personnel, and engineers must have security permissions to modify their respective faceplate tabs.

Display elements (global objects) have an associated faceplate that appears when the display element is clicked. Variables, setpoints, alarms, and other device configuration data is entered and viewed on the HMI faceplates.

The following table references the security codes that are required for each tag.

For more information on configuring FactoryTalk Security, see these manuals.

- PlantPAx® Distributed Control System  
Infrastructure Configuration, publication [PROCES-UM001](#)
- PlantPAx Distributed Control System  
Application Configuration, publication [PROCES-UM003](#)

**Table 13 - Security Codes**

FTView Tag	Description	Security Codes
Security\AlarmAck	Acknowledge/Reset Alarms	ABCDEF
Security\AlarmConfig	Alarm Configuration	E
Security\AlarmDisable	Disable Alarms	BCDEF
Security\AlarmShelve	Shelve Alarms	ABCDEF
Security\BypassFeedback	Can Bypass Feedback	CDE
Security\BypassInterlocks	Bypass Permissives and Interlocks	BCDEF
Security\CmdSrcMaint	Acquire/Release Equipment Maintenance Command Source	CDE
Security\CmdSrcOperProg	Acquire/Lock and Release Equipment Operator Command Source	BCDEF
Security\CmdSrcOutOfService	Can put device in/out of service	CDE
Security\ConfigSecurity	Change Security for the device	E
Security\DeviceConfigBehavior	Change the setup of the device (Advanced)	E
Security\DeviceConfigDiagnostics	Configure device diagnostics	CDE

**Table 13 - Security Codes**

FTView Tag	Description	Security Codes
Security\DeviceConfigFailTimers	Modify Alarm Delay Times	DE
Security\DeviceConfigHMI	Change the configuration of the HMI interface for the device	E
Security\DeviceConfigLimits	Configure device limits	DE
Security\DeviceConfigThresholds	Modify Limits and Deadbands	BCDEF
Security\DeviceConfigTimers	Configure device timers	DE
Security\DeviceConfigTuning	Change Tuning; Inflights; and Preacts	DE
Security\EnableSimulation	Put Device in Simulation	E
Security\EnterOperSettings	Enter Setpoints and Control Variables	ABCDEF
Security\OperateEquipment	Command Equipment in Operator Command Source	ABCDEF
Security\OverrideInputs	Override Inputs	CDE
Security\OverrideOutputs	Override Outputs	CDE
Security\ProcedureAdvancedExceptions	Exception Processing (Step Change; Parameter Change; Acquire; Reorder; Activate)	BCDEF
Security\ProcedureChangeParameters	Override Downloaded Phase Parameters	BCDEF
Security\ProcedureChangeSetpoints	Override Downloaded Setpoints	BCDEF
Security\ProcedureControl	Select; run; hold; and restart Procedures; Sequences; and Batches	ABCDEF
Security\ProcedureEquipmentControl	Manual Supervisory EP/EM Control	BCDEF
Security\ProcedureExceptions	Exception Processing (Resume; manual; Auto; Semi-Auto; Pause; Disconnect; Release)	ABCDEF
Security\ProcedureForceSequence	Force Steps/States	BCDEF
Security\ProcedureManualControl	Manual Procedure; Sequence; and Batch Processing (Stop; Abort; Reset)	ABCDEF
Security\ResetAccumulators	Reset Run Time Accumulators	CDE
Security\RespondToPrompts	Respond to Prompts	ABCDEF
Security>ShowFaceplate	Navigate to full faceplate	CDE

Display elements (global objects) have an associated faceplate that appears when the display element is clicked. Variables, setpoints, alarms, and other device configuration data is entered and viewed on the HMI faceplates.

Data cannot be entered or changed without an administrator granting permission with the corresponding security code on each faceplate tab.

**A**

- add**
  - HMI tag 26
  - ingredient 91
- addition**
  - material 73
  - resources 13
- advanced**
  - capabilities 87
- array**
  - size 30

**B**

- batch**
  - create 51
  - Manual ID generation 88
- before you begin** 6
- bit** 60
  - DN 60
  - interface 58, 91
  - state 60
- boolean**
  - mechanism 100
- built-in**
  - phase 46

**C**

- capabilities**
  - advanced 87
- changes**
  - summary 5
- components**
  - install 17
- configure**
  - controller files 17
  - easy recipe 68
  - master recipe 40
  - multi-step 65
  - phase 37
  - unit 35
- connect**
  - equipment to controller 55
- control**
  - equipment 65
  - operator phase 62
  - transfer 75
- controller files**
  - configure 17
- create**
  - batch 51

**D**

- data structure**
  - modify 30
- demonstration**
  - LBSM 69

**display**

- quick 9

**DN** 60**document**

- preface 5

**done**

- run until 92
- run until. continue until stop 96

**E****easy recipe**

- configuration 68

**engineering**

- tab 12

**equipment**

- connect logic 55
- control 65
- interface codes 89

**extract**

- LBSM zip files 7

**F****faceplate**

- LBSM 8

**functional**

- LBSM description 16

**G****global object**

- import 23

**guidelines**

- LBSM 16

**H****HMI**

- display import 25
- incorporate existing application 20
- security codes 101
- tag add 26

**I****ID**

- batch generation 88

**image**

- import 22

**import**

- global object 23
- HMI display 25
- image 22

**infrastructure**

- installation 7

**ingredient**

- add 91

**install**

- components 17
- infrastructure 7

**integer**

- mechanism 100

**interface**

- bit 58, 91
- phasemanager 56

**interface codes**

- equipment 89

**introduction**

- LBSM 15

**L****LBSM**

- demonstration 69
- extract zip files 7
- faceplate 8
- functional description 16
- guidelines 16
- incorporate into existing HMI 20
- install components 17
- introduction 15
- reporting 99
- size array 30
- software 5
- state model 6

**log**

- on demand
  - On-demand log 100

**logic**

- connect equipment 55

**M****manual**

- batch ID generation 88

**master**

- recipe configuration 40
- save recipe 53

**material**

- addition 73

**mechanism**

- boolean 100
- integer 100

**modify**

- data structure 30

**multi-step**

- configuration 65

**N****number**

- of phases 31
- of prompts 34
- of recipes 32
- of steps 33
- of units 30

**O****operator**

- phase control 62
- prompt 36
- tab 10

**P****phasemanager**

- interface 56

**parameter**

- set phase 44

**pause**

- skip 45

**phase**

- built-in 46
- configuration 37
- number 31
- operator control 62
- set parameter 44

**PIContinue**

- advanced capability 87

**PIImmRel**

- advanced capability 88

**PIOwned**

- advanced capability 88

**preface**

- document description 5

**prompt**

- number 34
- operator 36

**Q****quick**

- display 9

**R****recipe**

- number 32
- save master 53

**recored**

- retrieval 99

**reporting**

- LBSM 99

**retrieve**

- records 99

**run**

- until done 92
- until done, continue until stop 96
- until stopped 94

**run time detail**

- faceplate 71

**S****save**

- master recipe 53



**security codes**

HMI 101

**set**

phase parameter 44

wait timer 50

**size**

LBSM array 30

**skip**

pause 45

**software**

LBSM 5

**state**

bit 60

**state model**

LBSM 6

**step**

number 33

**stop**

run until 94

**summary of changes 5****T****tab**

engineering 12

operator 10

**timer**

set wait 50

**transfer**

of control 75

**U****UDT**

number of equipment phases in unit 36

**unit**

configuration 35

equipment phases UDT 36

number 30

**user-defined data types 36****W****wait**

set timer 50

**Z****zip files**

LBSM extraction 7

**Notes:**



## Rockwell Automation Support

Rockwell Automation provides technical information on the Web to assist you in using its products.

At <http://www.rockwellautomation.com/support> you can find technical and application notes, sample code, and links to software service packs. You can also visit our Support Center at <https://rockwellautomation.custhelp.com/> for software updates, support chats and forums, technical information, FAQs, and to sign up for product notification updates.

In addition, we offer multiple support programs for installation, configuration, and troubleshooting. For more information, contact your local distributor or Rockwell Automation representative, or visit <http://www.rockwellautomation.com/services/online-phone>.

## Installation Assistance

If you experience a problem within the first 24 hours of installation, review the information that is contained in this manual. You can contact Customer Support for initial help in getting your product up and running.

United States or Canada	1.440.646.3434
Outside United States or Canada	Use the <a href="#">Worldwide Locator</a> at <a href="http://www.rockwellautomation.com/rockwellautomation/support/overview.page">http://www.rockwellautomation.com/rockwellautomation/support/overview.page</a> , or contact your local Rockwell Automation representative.

## New Product Satisfaction Return

Rockwell Automation tests all of its products to help ensure that they are fully operational when shipped from the manufacturing facility. However, if your product is not functioning and needs to be returned, follow these procedures.

United States	Contact your distributor. You must provide a Customer Support case number (call the phone number above to obtain one) to your distributor to complete the return process.
Outside United States	Please contact your local Rockwell Automation representative for the return procedure.

## Documentation Feedback

Your comments will help us serve your documentation needs better. If you have any suggestions on how to improve this document, complete this form, publication [RA-DU002](#), available at <http://www.rockwellautomation.com/literature/>.

Allen-Bradley, FactoryTalk, Logix 5000, PhaseManager, Plant PAx, RSLinx, Rockwell Software, Rockwell Automation, SequenceManager, and Studio 5000 Logix Designer are trademarks of Rockwell Automation, Inc.  
Trademarks not belonging to Rockwell Automation are property of their respective companies.

Rockwell Automation maintains current product environmental information on its website at <http://www.rockwellautomation.com/rockwellautomation/about-us/sustainability-ethics/product-environmental-compliance.page>.

Rockwell Otomasyon Ticaret A.Ş., Kar Plaza İş Merkezi E Blok Kat:6 34752 İçerenköy, İstanbul, Tel: +90 (216) 5698400

**[www.rockwellautomation.com](http://www.rockwellautomation.com)**

### Power, Control and Information Solutions Headquarters

Americas: Rockwell Automation, 1201 South Second Street, Milwaukee, WI 53204-2496 USA, Tel: (1) 414.382.2000, Fax: (1) 414.382.4444  
Europe/Middle East/Africa: Rockwell Automation NV, Pegasus Park, De Kleetlaan 12a, 1831 Diegem, Belgium, Tel: (32) 2 663 0600, Fax: (32) 2 663 0640  
Asia Pacific: Rockwell Automation, Level 14, Core F, Cyberport 3, 100 Cyberport Road, Hong Kong, Tel: (852) 2887 4788, Fax: (852) 2508 1846

Publication PROCES-RM007C-EN-P - September 2018

Supersedes Publication PROCES-RM007B-EN-P - May 2016

Copyright © 2018 Rockwell Automation, Inc. All rights reserved. Printed in the U.S.A.