

Series 3

# WebRelay-Dual™

## User's Manual

Revision 1.7

Covers Models:

- X-301-I
- X-301-24I
- X-301-E

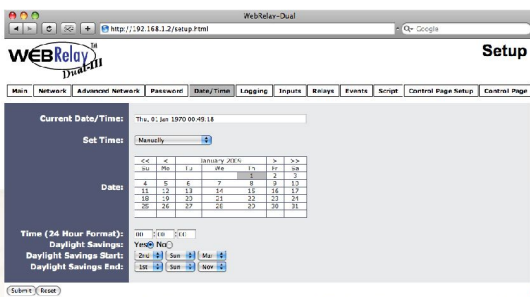

Web Enabled

- Relays
- I/O
- Scheduler

**CONTROL** by **WEB**™  
www.ControlByWeb.com

a division of...  
Xytronix Research & Design, Inc  
Nibley, Utah, USA

## Contents

### Trademark and Copyright Information

### Warranty

### FCC Statement

### Installation Guidelines (Read Before Installing)

#### Section 1: Introduction

##### 1.1 Features

##### 1.2 WebRelay-Dual™ Models Available

##### 1.3 Connectors & Indicators

##### 1.4 Options for Accessing the WebRelay-Dual™

##### 1.5 Example Configurations and Applications

1.5.1 Basic Application Example; School Bell/Shift Change Bell Controller

1.5.2 Multiple Device Example; School Bell/Shift Change Bell Controller with Multiple Bells

1.5.3 Two Relay Example; Traffic Warning Light Controller

1.5.4 Security Example; Control of Electric Locks

1.5.5 Control Example; Timed Control of Electrical Outlets

1.5.6 Event Counter Example

1.5.7 Extending Signals (Peer-to-Peer Operation)

#### Section 2: Installation and Setup

##### 2.1 Mounting

2.1.1 Wall Mounting

2.1.2 DIN-Rail Mounting

##### 2.2 Connection

2.2.1 Power Supply Connection

2.2.2 Network Connection

2.2.3 Relay Connection

2.2.4 Optically-Isolated Input Connection

##### 2.3 Establishing Communications for Setup

2.3.1 Option 1: Assign a temporary IP address to WebRelay-Dual™

2.3.2 Option 2: Assign a temporary IP address to configuration computer

2.3.3 Open Configuration Web Page

##### 2.4 WebRelay-Dual™ Setup Pages

2.4.1 Main Tab

2.4.2 Network Tab

2.4.3 Advanced Network Tab

2.4.4 Password Tab

2.4.5 Date/Time Tab

2.4.6 Logging Tab

2.4.7 Inputs Tab

2.4.8 Relays Tab

2.4.9 Events Tab

2.4.10 Script Tab

2.3.11 Control Page Setup Tab

## **Section 3: Operation**

### **3.1 Browser Operation**

### **3.2 XML Operation**

3.2.1 Controlling The Unit Through state.xml

3.2.2 Monitoring Events Through eventX.xml

3.2.3 XML Diagnostics

### **3.3 Configuring Events Through Get Requests**

### **3.4 Modbus Operation**

3.4.1 Read Coils (Modbus Function Code 01 (0x01))

3.4.2 Read Discrete Inputs (Modbus Function Code 02 (0x02))

3.4.3 Read Holding Registers (Modbus Function Code 03 (0x03))

3.4.4 Write Single Coil (Modbus Function Code 05 (0x05))

3.4.5 Write Multiple Coils (Modbus Function Code 15(0x0F))

3.4.6 Write Multiple Registers (Modbus Function Code 16 (0x10))

### **3.5 Email Notification**

3.5.1 Email Notification Description

3.5.2 Email Notification Setup

## **Appendix A: Restoring Factory Default Settings**

## **Appendix B: Installing New Firmware**

## **Appendix C: Accessing WebRelay-Dual™ Over the Internet**

## **Appendix D: Log Files**

## **Appendix E: External Server and Remote Services**

## **Appendix F: SNMP Requests, Objects, and Community Strings**

## **Appendix G: BASIC Scripts**

## **Appendix H: Specifications**

## **Appendix I: Mechanical Information**

## Trademark and Copyright Information

This document is Copyright ©2005-2018 by Xytronix Research & Design, Inc. All rights reserved.

X-301™WebRelay-Dual™, WebRelay™, ControlByWeb™, and Xytronix Research & Design™ are trademarks of Xytronix Research & Design™, Inc. 2005-2018.

All parts of this product and design including but not limited to firmware, hardware design, schematics, PCB layout, concept, graphics, users manual, etc., are property of Xytronix Research & Design, Inc. ©2005-2018. WebRelay-Dual™ may not be opened, disassembled, copied or reverse-engineered.

No part of this manual may be reproduced or transmitted in any form or by any means, electronic or mechanical, including photocopying or scanning, for any purpose other than the personal use by the purchaser of this product. Xytronix Research & Design, Inc., assumes no responsibility for any errors that may appear in this document.

Whereas reasonable effort has been made to make the information in this document as useful and accurate as possible, Xytronix Research & Design, Inc. assumes no responsibility for the application, usefulness, or completeness of the information contained herein. Under no circumstance will Xytronix Research & Design, Inc. be responsible or liable for any damages or losses including direct, indirect, special, incidental, or consequential damages or losses arising from either the use of any information contained within this manual or the use of any products or services referenced in this manual.

Xytronix Research & Design, Inc. reserves the right to change any product's features, specifications, documentation, warranties, fee schedules, and conditions at any time and without notice.

## Warranty

This Xytronix Research & Design, Inc. product has a warranty against defects in material and workmanship for a period of one year from the date of shipment. During the warranty period, Xytronix Research & Design, Inc. will, at its option, either repair or replace products that prove to be defective. This warranty is extended to the original purchaser of the equipment only.

For warranty service or repair, the product must be properly packaged, and returned to Xytronix Research & Design, Inc. The purchaser shall prepay all charges for shipping to Xytronix Research & Design, Inc., and Xytronix Research & Design, Inc. will pay the shipping charges to return the product to the purchaser as long as the product is shipped within the United States. If the product is shipped outside of the United States, the purchaser shall pay all shipping charges, duties, and taxes.

### Limitation

The foregoing warranty shall not apply to defects or damage resulting from improper use or misuse, unauthorized repair, tampering, modification, improper connection, or operation outside the electrical/environmental specifications for the product. Further, the warranty does not cover Acts of God, such as fire, flood, hurricanes, and tornadoes. This warranty does not cover damage to property, equipment, direct, indirect, consequential, or incidental damage (including damage for loss of business profit, business interruption, loss of data, and the like) arising out of the use or misuse of this product.

UNDER NO CIRCUMSTANCES WILL THE LIABILITY OF XYTRONIX RESEARCH & DESIGN, INC. TO THE PURCHASER OR ANY OTHER PARTY EXCEED THE ORIGINAL PURCHASE PRICE OF THE PRODUCT, REGARDLESS OF THE FORM OF THE CLAIM. No other warranty is expressed or implied. Xytronix Research & Design, Inc. specifically disclaims the implied warranties or merchantability and fitness for a particular purpose. Some jurisdictions may not allow the exclusion of limitation of liability for consequential or incidental damage.

## FCC Statement

This device complies with Part 15 of the FCC Rules. Operation is subject to the following two conditions:

- This device may not cause harmful interference.
- This device must accept any interference received, including interference that may cause undesired operation.

### **Warning:**

This equipment has been tested and found to comply with the limits for a Class B (Class A for POE models) digital device, pursuant to Part 15 of the FCC Rules. These limits are designed to provide reasonable protection. This equipment generates, uses and can radiate radio frequency energy and, if not installed and used in accordance with the instructions, may cause interference to radio communications. There is no guarantee, however, that interference will not occur in a particular installation. If this equipment does cause harmful interference to radio or television reception, which can be determined by turning the equipment off and on, the user is encouraged to try to correct the interference by one or more of the following measures:

- Reorient or relocate the receiving antenna.
- Increase the separation between the equipment and receiver.
- Connect the equipment into an outlet or a circuit different from that to which the receiver is connected.
- Consult the dealer or an experienced radio/TV technician for help

### **Notice:**

Changes or modification not expressly approved by the party responsible for compliance could void the user's authority to operate the equipment.

## Installation Guidelines (Read Before Installing)

- Do not open the WebRelay-Dual™ enclosure. This could damage the unit or cause personal harm and will void the warranty.
- This unit must be installed by qualified personnel.
- This unit must not be installed directly outdoors.
- This unit must not be used for medical, life saving purposes, or for any purpose where its failure could cause serious injury or the loss of life.
- This unit must not be used in any way where it's function or failure could cause significant loss or property damage.

### Notes About Security

By design, WebRelay-Dual™ is very secure. It does not support terminal or file transfer programs such as telnet, FTP, SSH, etc. This means it is not possible for someone to 'break in' to WebRelay-Dual™ and access other devices on your local network. The simplicity of the WebRelay-Dual™ makes it a very secure device. As with any device to be installed on a network, there are some security precautions that should be observed. If WebRelay-Dual™ is installed on the Internet, it is recommended that passwords be enabled for the **Control Page**. Make sure secure passwords are used. Passwords should be at least 8 characters in length and should be a combination of upper case letters, lower case letters, and numbers. Don't use passwords that would be easy to guess. For additional security, a firewall may be used to limit access only to selected IP addresses. Another option may be to set up a Virtual Private Network (VPN) between the network where the WebRelay-Dual™ resides and the client machine (web browser, another, ControlByWeb™ product, etc.).

### Final Installation Note

This ControlByWeb™ product supports connection to 10Mbps and 100Mbps networks. Although 100Mbps networks are faster, the amount of data transferred to and from this device is very minimal and little if any performance increase will be gained by setting it to 100Mbps. There are advantages, however, to operate this device at 10Mbps. At 10Mbps, less power is required, the unit runs cooler, and the lifetime of the product will be extended.

## Section 1: Introduction

WebRelay-Dual™ is an Ethernet based, high performance, mini I/O module that has two electro-mechanical relays, two optically-isolated inputs, non-volatile memory for logging, and a real-time clock for full-calender scheduling. It can be controlled and/or monitored over any IP network including private networks, IP-based industrial control networks, and the Internet. Users can operate the WebRelay-Dual™ using a web browser, or custom applications can be written to control the WebRelay-Dual™ from a computer, PLC, or other automation controller. It can also be configured to automatically turn relays on/off at preset times using its advanced scheduler. In addition, custom control scripts can be written and executed using BASIC programming language.

WebRelay-Dual™ has two optically-isolated inputs that can be used for simple monitoring of discrete (digital) signals such as alarm outputs from a machine, security sensors, switches, etc. The optically-isolated inputs can also be used to control the relays (on/off, pulse, toggle, latch), or they can even be configured to control relays on another ControlByWeb™ device at a remote location. This feature provides the ability for remote control without the use of a computer. For example, an alarm signal connected to an WebRelay-Dual™ in one building can trigger an alarm connected to a WebRelay-Dual™ (or other ControlByWeb™ device) in another building across the country.

WebRelay-Dual™ is the ideal drop-in solution for many applications that require scheduling and Internet control. Example applications include control of street signs, school or work shift bells, 1 or 2 zone sprinkler systems, electronic locks, and much more.

### 1.1 Features

WebRelay-Dual™ is very simple but has many features, including:

- No programming required.
- Easy to use as a stand alone device or as part of a large control system.
- Built-in web server provides simple, web based configuration and control.
- Control page can be customized with appropriate text and buttons
- Two 3-Amp, 28VAC/24VDC relays.
- Field Re-programmable: users can install firmware updates when available.
- Two optically-isolated inputs can be used for status monitoring, local relay control, or remote relay control.
- Real-time clock with yearly calender allows relays to be programmed to turn on/off at preset times.
- Up to 100 one-time or repeated events can be set up.
- Data logging.
- Configure manually or with DHCP.
- Remote Services option allows the WebRelay-Dual™ to initiate connection to external servers.
- XML status pages provides an easy way to interface with custom applications.
- Supports Simple Network Management Protocol (SNMP).
- Modbus/TCP protocol support provides interoperability with devices/software from other manufacturers.
- Supports BASIC scripts for advanced configuration.
- Password protection.
- Selectable TCP ports.
- On/Off or pulse modes.
- Input high timer automatically keeps track of time that input 1 is high (XML readable only).
- Removable terminal connector (included) simplifies wiring.
- Compact, DIN-Rail mountable enclosure.
- 10/100 Ethernet connectivity.



## 1.2 WebRelay-Dual™ Models Available

WebRelay-Dual™ is currently available in three models with only two differences between each model. One difference is the power supply requirements and the other difference is the input voltage range on the optically-isolated inputs.

<b>Part Number</b>	<b>Power Supply Requirements</b>	<b>Optically-Isolated Input Voltage Range</b>
X-301-I	9-28VDC	4-12VDC
X-301-24I	9-28VDC	11-26VDC
X-301-E	Power Over Ethernet (802.3af or 5VDC)	4-12VDC

### 1.3 Connectors & Indicators

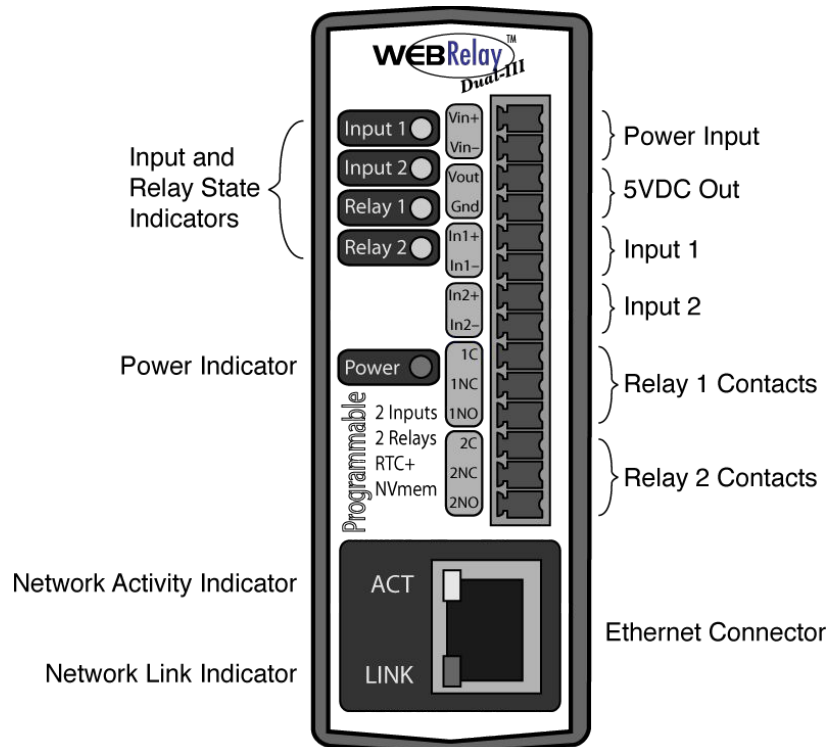

Figure 1.3a—Connectors and Indicators

WebRelay-Dual™ has a 14-position removable terminal connector and an Ethernet connector. The terminal connector is used to provide power to the module and to provide a connection to the relay contacts and optically-isolated inputs. The Ethernet connector is used to connect the module to the network.

There are seven LED indicators on the WebRelay-Dual™. One LED is labeled Power, which is illuminated (green) whenever the module is powered. Two LEDs are labeled Input 1 and Input 2. These are illuminated (yellow) whenever a voltage is applied to the corresponding input. Two LEDs are labeled Relay 1 and Relay 2. These are illuminated (yellow) whenever the corresponding relay coil is energized. When the relay coil is energized, the NO (Normally Open) contact is closed and the NC (Normally Closed) contact is open. The other two LEDs are located on the Ethernet connector. They are labeled LINK and ACT. LINK is illuminated (green) when the module is properly connected to an Ethernet network. This LED must be illuminated before any communications can take place with the module. The ACT LED flashes when activity is detected on the network.

## 1.4 Options for Accessing WebRelay-Dual™

WebRelay-Dual™ is a flexible, self-contained instrument and requires NO COMPUTER to operate. It can be used as a single stand-alone device or as part of a large system. It can be accessed directly from a computer or indirectly through a large server. It can be accessed using a web browser, or using custom software.

### 1.4.1 Basic Access Using A Web Browser

WebRelay-Dual™ has a built-in web server and provides simple web pages that can be accessed using a standard web browser. This allows users to access the unit with NO SPECIAL SOFTWARE installed on their computer. This is ideal for basic applications that require a quick, simple solution that does not need to be accessible to more than a few people. This configuration is simple to set up, simple to use, and can be accessed from any computer without the installation of software. Note that computers that are not on the local network may only access the WebRelay-Dual™ if the local network router is setup to allow this.

### 1.4.2 Accessing WebRelay-Dual™ with Custom Software or Third Party Applications

WebRelay-Dual™ provides a programming interface that allows applications running on a computer to have full access to it. Custom applications can send commands to the WebRelay-Dual™ for monitoring and control. Custom applications can be used to provide a custom-user interface, provide access to multiple units in a single screen, automation, logging, etc. The benefit of using custom software to access the WebRelay-Dual™ is that flexibility is almost unlimited.

### 1.4.3 Using an external Web Server

Rather than accessing WebRelay-Dual™ directly from a computer, an external web server can be used. The term “external” web server is used here to mean a separate web server (such as Apache or IIS) that is not the web server built into WebRelay-Dual™. In this scenario, users access custom web pages that reside on the external web server and the external web server communicates with the WebRelay-Dual™. Users would not communicate directly with the WebRelay-Dual™.

Using an external web server to provide a custom user interface is beneficial because multiple WebRelay-Dual™ devices (or other ControlByWeb™ products) can be integrated into a single control page or set of pages so they appear as part of a larger system rather than individual devices. In other words, the user may not be aware that he/she is using multiple WebRelay-Dual™ devices, but rather the user sees a custom control page that shows the temperature in every room in a building. In addition, the use of an external web server allows programmers to create custom user interfaces that take advantage of the additional resources typically available on larger web servers including more memory and various web programming languages.

There are two approaches that an external server can use to communicate with WebRelay-Dual™ and other ControlByWeb™ devices. The first approach is for the external server to create a TCP connection whenever it needs to access the WebRelay-Dual™. In this case, the external server opens the connection, sends commands and/or reads the device, and closes the connection. The second approach is for the WebRelay-Dual™ to initiate a connection. Using the “Remote Services” settings under the **Advanced Network** tab in the setup pages, the WebRelay-Dual™ can be configured to open a TCP connection with an external server. Once the connection is open, the external server can send commands and/or read the device. The external server can leave the connection open (so that it never closes) or close the connection.

Each of the two approaches is appropriate for different applications. The first approach is ideal when the the web server and all of the WebRelay-Dual™ devices are on the same network (without routers between them). In this case, the server can communicate with the WebRelay-Dual™ devices directly and security concerns are minimal because data never has to leave the local network. When the server and the WebRelay-Dual™ devices are on different networks, the first approach can still be used, but routers that are installed between them must be configured to allow appropriate access. For companies that own or control the networks where all of these devices are installed, this is not a problem. Anytime a public network is used (the Internet), however, security precautions should be implemented.

The second approach described above uses “Remote Services” features and is ideal for installations where the server and the WebRelay-Dual™ devices are installed on different networks. This is especially useful when each WebRelay-Dual™ is installed on a separate private network.

For example, if the user doesn't own or control any of the network connections where the WebRelay-Dual™ is to be installed, “Remote Services” in the WebRelay-Dual™ may be enabled for the WebRelay-Dual™ to connect to their computer. By using the “Remote Services” configuration, the WebRelay-Dual™ initiates a TCP connection over the Internet with the control computer. Since the WebRelay-Dual™ initiates the connection, the control computer doesn't have to know the IP address of the WebRelay-Dual™. This means that the WebRelay-Dual™ can be installed using DHCP to obtain a dynamic IP address. In addition, no special router configuration is required. This makes the network installation of the WebRelay-Dual™ very simple, and since no incoming ports need to be opened up in the router, security is not compromised.

See the description of the **Advanced Network** tab in chapter 2.5 for more information.

### 1.5 Example Configurations and Applications

WebRelay-Dual™ is very versatile and can be used in many applications. Some example applications are illustrated in this section to show how it can be used.

#### 1.5.1 Basic Application Example; School Bell / Shift Change Bell Controller

The illustration below shows a simple example of using the WebRelay-Dual™ to control a device over an IP network. In this case, the device being controlled is a bell which is wired in series with the relay contacts. The WebRelay-Dual™ can be configured to automatically sound the bell at preset times. Users can also manually control the bell using a web browser.

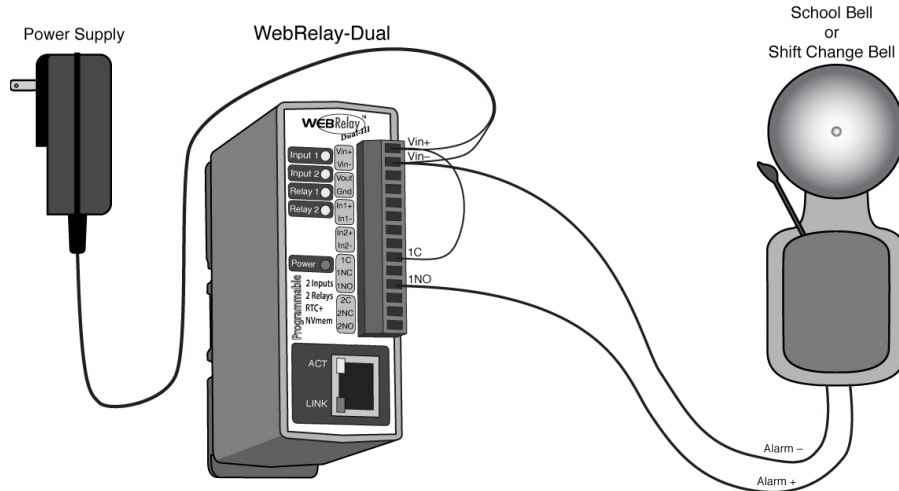

Figure 1.5a—School Bell or Shift Change Bell Controller

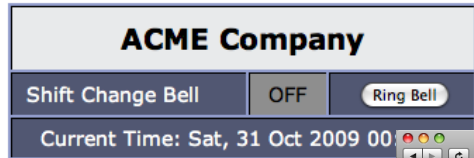

Figure 1.5b—Control Page

Event #	Start Date/Time	Period	Count	Relay #	Action	Pulse	Next Occurrence
00 - Morning Shift	Th 11/05/2009 08:00:00	M Tu W Th F	0	1	pulse relay	2 Secs	F 11/06/2009 08:00:00
01 - Begin Lunch	Th 11/05/2009 12:00:00	M Tu W Th F	0	1	pulse relay	2 Secs	Th 11/05/2009 12:00:00
02 - End Lunch	Th 11/05/2009 13:00:00	M Tu W Th F	0	1	pulse relay	2 Secs	Th 11/05/2009 13:00:00
03 - Shift End	Th 11/05/2009 00:00:00	M Tu W Th F	0	1	pulse relay	2 Secs	F 11/06/2009 00:00:00
04 - Disabled							
05 - Disabled							
06 - Disabled							
07 - Disabled							
08 - Disabled							
09 - Disabled							
10 - Disabled							
11 - Disabled							
12 - Disabled							
13 - Disabled							
14 - Disabled							
15 - Disabled							
16 - Disabled							
17 - Disabled							
18 - Disabled							
19 - Disabled							
20 - Disabled							
21 - Disabled							
22 - Disabled							
23 - Disabled							
24 - Disabled							
25 - Disabled							
26 - Disabled							
27 - Disabled							
28 - Disabled							
29 - Disabled							
30 - Disabled							

Figure 1.5c—Event Scheduler

### 1.5.2 Multiple Device Example; School Bell / Shift Change Bell Controller with Multiple Bells

This example uses the peer-to-peer connectivity feature in ControlByWeb™ products to control multiple bells at different locations. In this example, the WebRelay-Dual™ acts as the main controller and switches one of its relays on/off to control one of the bells. The WebRelay-Dual™ is configured to send a message to WebRelay #1 each time the state of relay 1 changes. WebRelay #1 may be located at another location within the same building or at a remote location. When WebRelay #1 gets the message to turn on its relay, it sounds the bell and sends a message to WebRelay #2 which is located elsewhere. WebRelay #2 then sounds its bell and sends a message to WebRelay #3, located elsewhere, sounding its bell.

The example illustrates three bells, but many units can be "daisy-chained" in a similar way. On a good network, the message propagates from device to device very quickly and with a small number of bells, the delay between the first bell and the last is usually not noticeable.

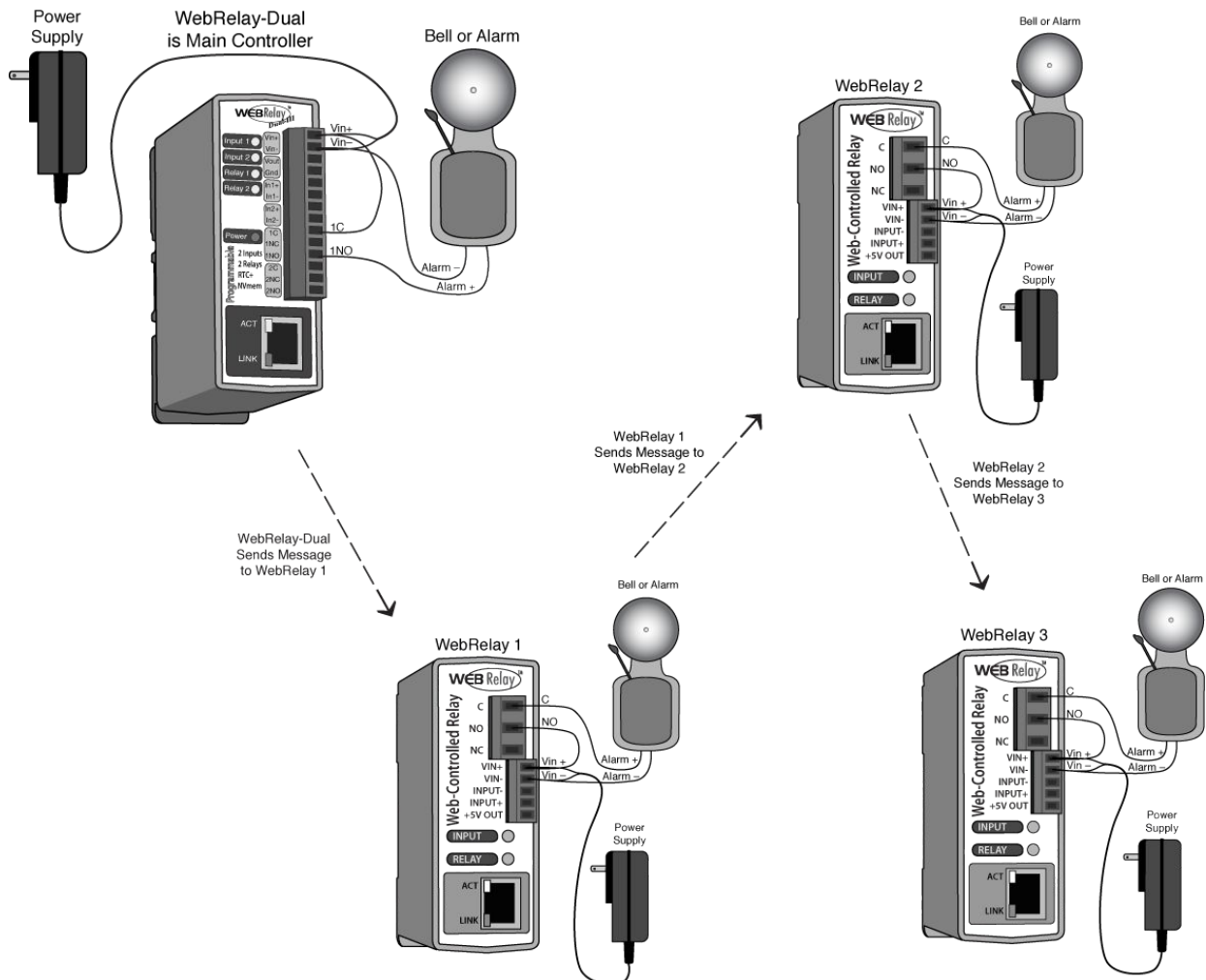

Figure 1.5d—Multiple Bell Controller

### 1.5.3 Two Relay Example; Traffic Warning Light Controller

This example shows how the WebRelay-Dual™ can be used to control a traffic warning light. In this example, the WebRelay-Dual™ is configured with a BASIC script (given in **Appendix G: Basic Scripts**) that will alternately flash two lights when enabled and turn both lights off when not enabled. The flashing lights can be enabled automatically through the built-in scheduler, manually using a web browser, or manually by pushing a button that starts a timer to enable the lights for a time period. Figure 1.5f below shows screenshots of the control page the user could use to manually turn the lights on or off (on the right) plus two setup pages used by the installer to create the control page.

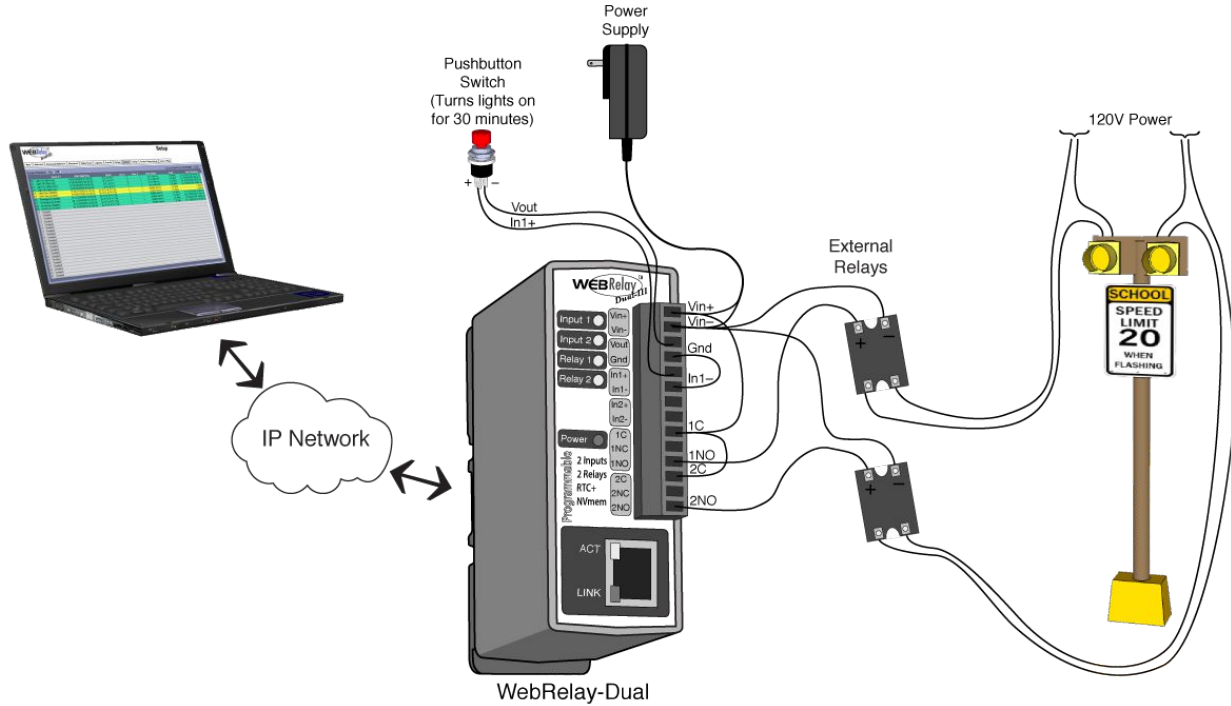

Figure 1.5e—Traffic Warning Light Controller

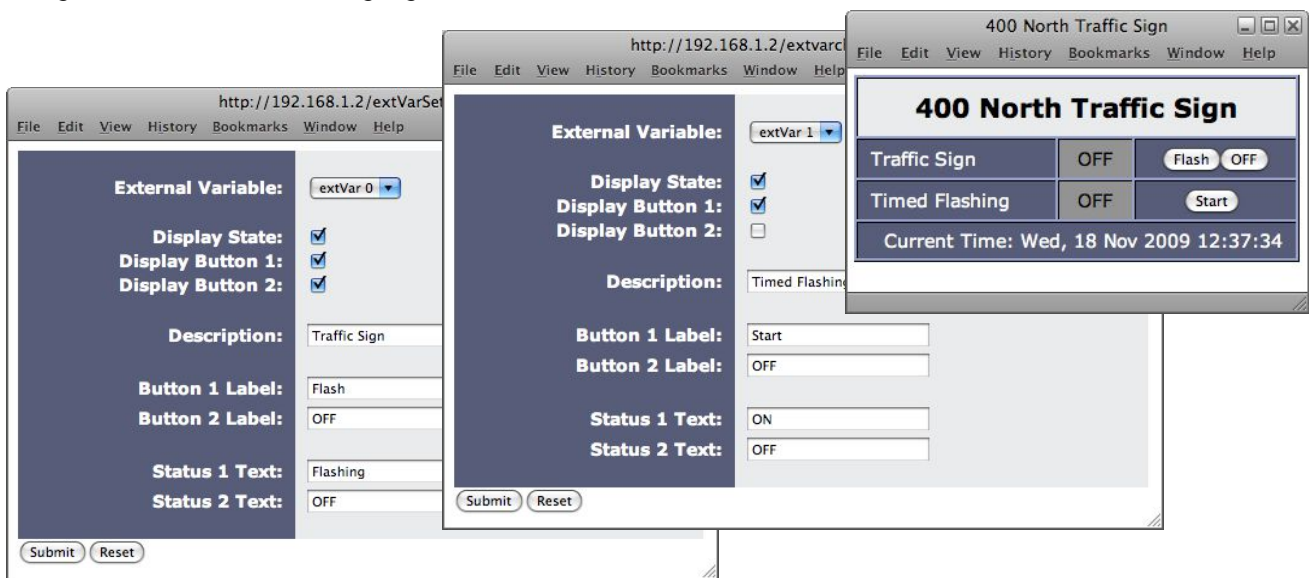

Figure 1.5e—Traffic Warning Light Screenshots

### 1.5.4 Security Example; Control of Electric Locks

This example shows how the WebRelay-Dual™ can be used to control electric locks. In this case, one of the relays in the WebRelay-Dual™ is connected to a large magnetic lock. A reverse-bias diode is connected in parallel with the lock to protect the relay contacts from the inductive kickback that will occur when the lock is switched. The example also illustrates how the input can be used to indicate when the door is open or closed.

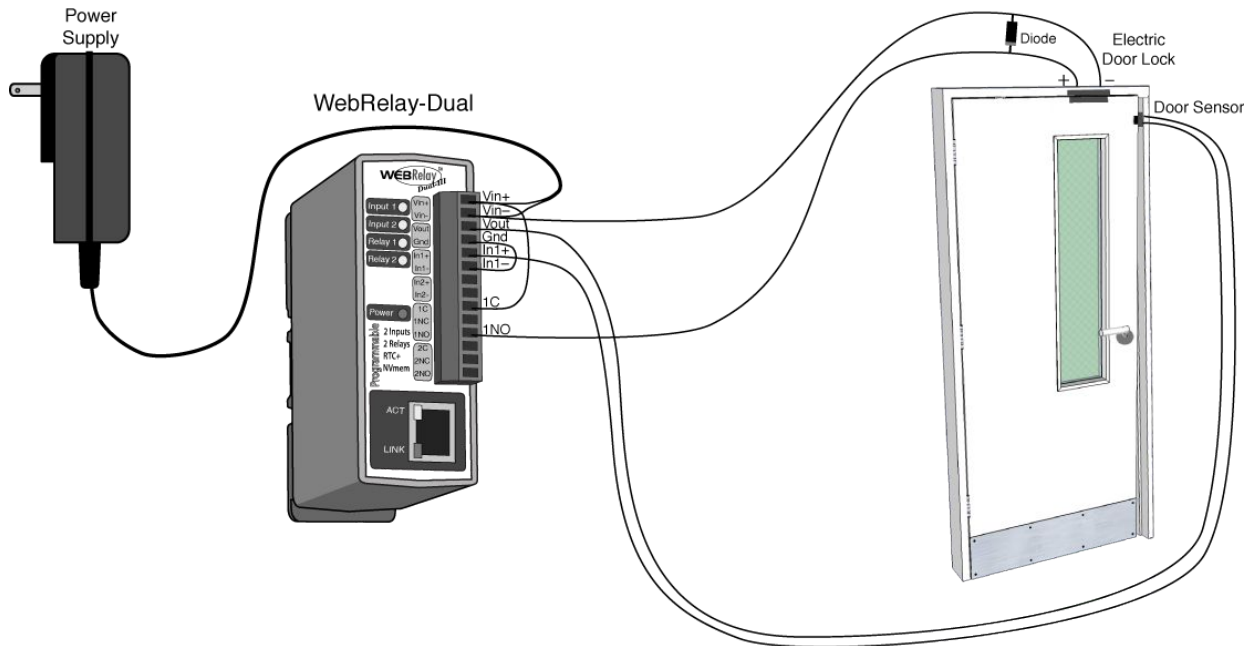

Figure 1.5g—Electric Lock Control

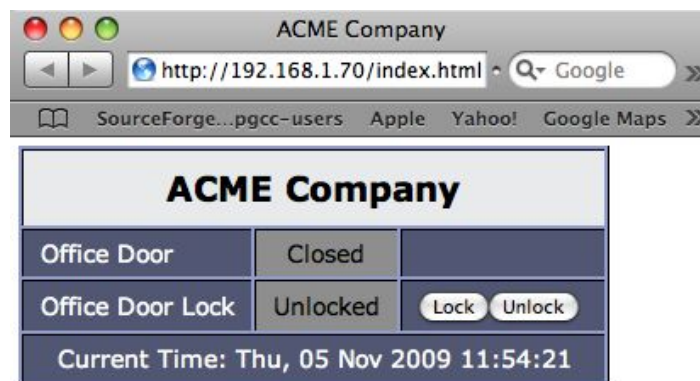

Figure 1.5h—Door Lock Control Page



### 1.5.5 Control Example; Timed Control of Electrical Outlets

This example shows how the WebRelay-Dual™ can be used to control electrical outlets in a building. This is useful to make sure certain equipment gets shut down at night when it is not in use. This is done by wiring the outlets of the building to relays that are controlled by the WebRelay-Dual™. The WebRelay-Dual™ is programmed to shut off the outlets when the building is vacant. If the schedule changes, the outlets can be turned on using a web browser, or a pushbutton switch can be tied to an input of the WebRelay-Dual™ that will turn on the outlets for a given time period (for example, 3 hour occupancy).

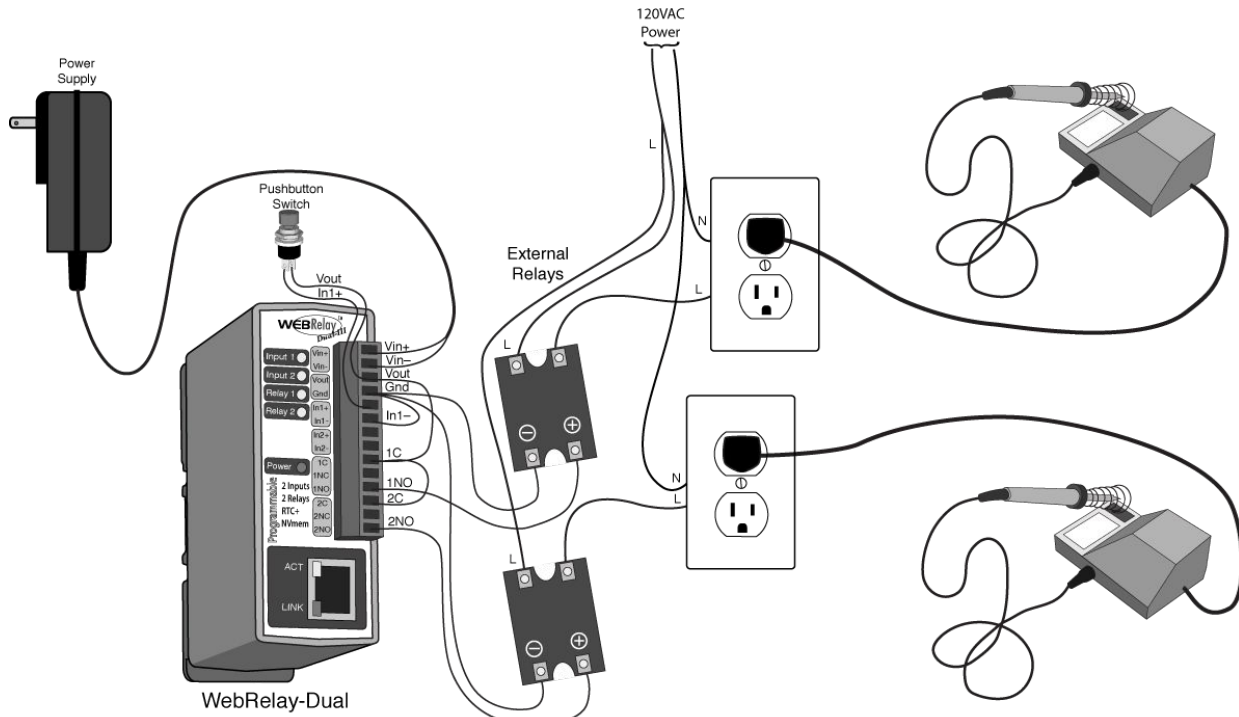

Figure 1.5i—Timed Control of Electrical Outlets

### 1.5.6 Event Counter Example

This example illustrates how the WebRelay-Dual™ can be used to count events. A sensor with dry contacts or the output of another device can be connected to the input of the WebRelay-Dual™. The input is configured to count. The count can be read through the XML file or displayed on the web page.

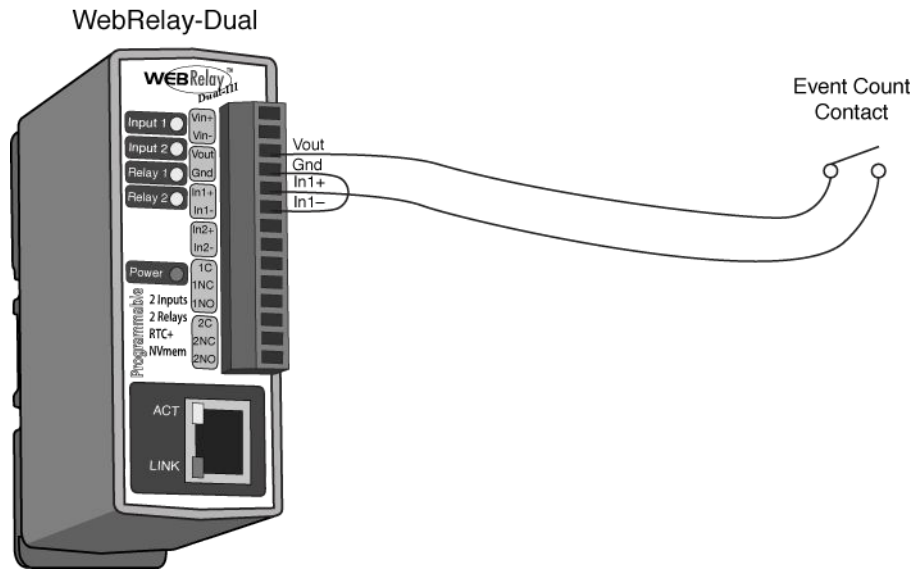

Figure 1.5j—Event Counter

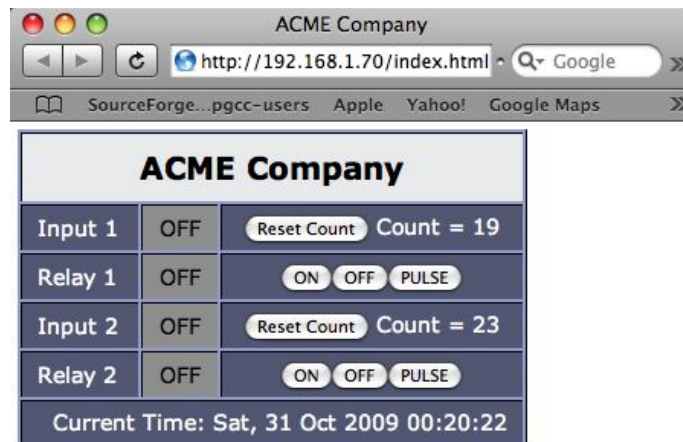

Figure 1.5k—Counter Control Page

### 1.5.7 Extending Signals (Peer-to-Peer operation)

The peer-to-peer configuration is used to control devices remotely without a browser, or to simply extend a digital signal to a remote location on the network. A control voltage applied to one unit controls the relay contacts of another unit at a remote location. The WebRelay-Dual™ can also send and receive messages to/from other ControlByWeb™ devices such as WebRelay™, WebRelay-Quad™, the DAQ Series™ Five Input Module™, etc.

This configuration has many uses. Two examples are briefly described below.

For security applications, the switch in the example could be replaced with a sensor, and the device to be controlled could be a buzzer or chime. A business owner, for example, could set up a sensor at his/her office and a chime at his/her home. The chime at the home would announce each time the sensor detects entry to the office (which may be miles away). When the chime indicates office entry late at night, the business owner can take appropriate action.

Another way this configuration is useful is to extend the output of a PLC (Programmable Logic Controller) in a factory to control motors, lights, etc., in another building. Digital outputs from a PLC are connected to the inputs of one WebRelay-Dual™, and the load devices (motors, lights, etc.) are connected to the relay contacts of a second WebRelay-Dual™ (loads larger than 1 Amp at 28V must use an external relay). This allows any PLC to control devices across an IP network. This configuration is also useful to connect digital signals (on/off) from a remote location to the input of a PLC.

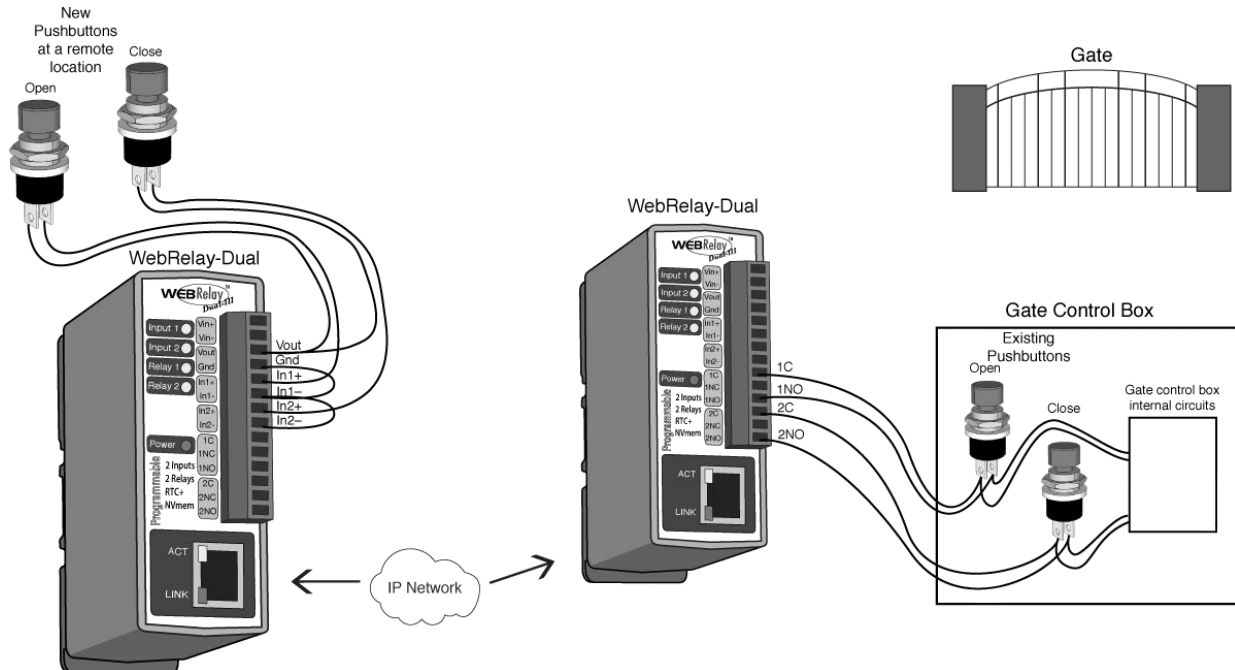

Figure 1.5.1—Peer to Peer Operation

## Section 2: Installation and Setup

Installation consists of mounting the WebRelay-Dual™, connecting to an IP network, providing power, configuring via a web browser, and wiring relay contacts to the device that will be controlled. Optionally, control signals may be connected to the optically-isolated inputs.

### 2.1 Mounting

WebRelay-Dual™ can be wall mounted or DIN rail mounted. It should be mounted in a clean, dry location where it is protected from the elements. Ventilation is recommended for installations where ambient air temperature is expected to be high.

#### 2.1.1 Wall Mounting

Mount the WebRelay-Dual™ to a wall by using two #8 screws. Attach the screws to the wall vertically spaced exactly 2.5 inches apart. The head of the screws should be about 1/10 inch away from the wall. See **Appendix I: Mechanical Information** for more details.

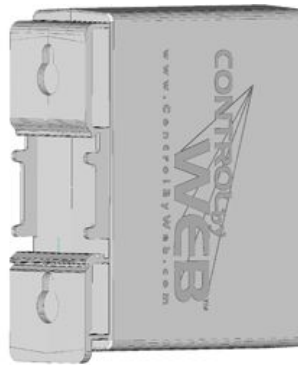

Figure 2.1a—Wall Mounting

#### 2.1.2 DIN-Rail Mounting

The WebRelay-Dual™ can be mounted to a standard (35mm by 7.5mm) DIN rail. Attach the WebRelay-Dual™ to the DIN rail by hooking the top hook on the back of the enclosure to the DIN rail and then snap the bottom hook into place. Remove the WebRelay-Dual™ from the DIN rail using a flat-head screwdriver. Insert the screwdriver into the notch in the release tab and pry against the enclosure to release the bottom hook.

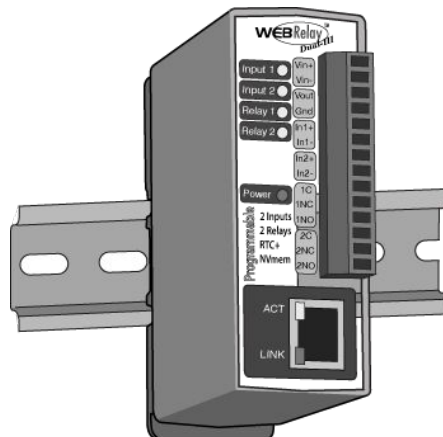

Figure 2.1b—DIN-Rail Mounting

## 2.2 Connection

**CAUTION: MAKE SURE POWER IS SHUT OFF BEFORE WIRING!**

**CAUTION: THIS UNIT SHOULD BE INSTALLED BY A QUALIFIED TECHNICIAN.**

**MIS-WIRING OR MIS-CONFIGURATION COULD CAUSE PERMANENT DAMAGE TO THE WebRelay-Dual™ AND/OR THE EQUIPMENT TO WHICH IT IS CONNECTED.**

A removable terminal connector is provided for simple wiring. The correct wiring procedure is as follows:

1. Make sure power is turned off.
2. Remove the terminal connector from the WebRelay-Dual™ and make wiring connections to the terminals.
3. Reconnect terminal connectors.
4. Apply power.

It is recommended that the load (device to be controlled) not be connected to the WebRelay-Dual™ until after the WebRelay-Dual™ has been configured and tested. By doing this, wiring and configuration mistakes will not cause the load device to turn on unexpectedly.

**IMPORTANT: MAKE SURE WIRES ARE PROPERLY ATTACHED TO THE TERMINALS AND THAT THE TERMINALS ARE TIGHT!**

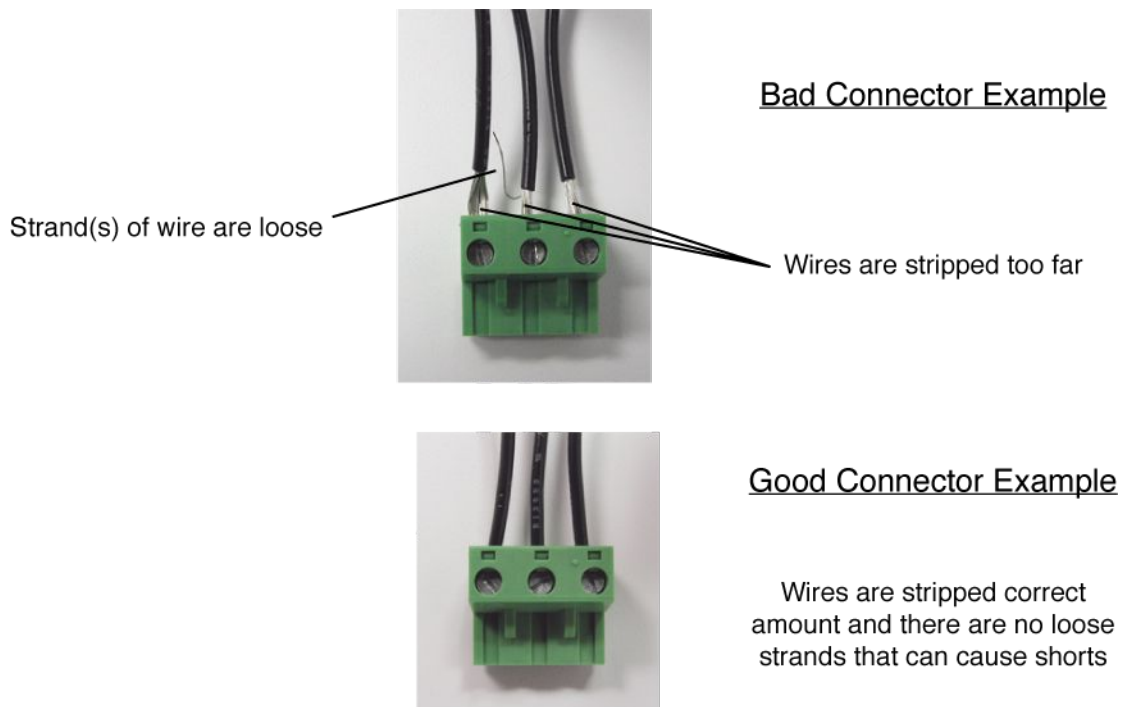

Figure 2.1c—Connection

<b>14-Pin Connector Pinout</b>	
<b>Pin</b>	<b>Description</b>
VIn+	Power supply input. Connect to the positive side of the appropriate power supply. DO NOT EXCEED THE MAXIMUM POWER SUPPLY VOLTAGE.  <u>Model X-301-I and X-301-24I</u> 9~28VDC Power supply  <u>Model X-301-E</u> Power Over Ethernet model. These units do not require a power supply to be connected to this pin when the unit is connected to an 802.3af compliant network. Alternatively, this model can be powered using a 5VDC power supply.
VIn-	VIn- Negative power supply input.
+5	+5VDC Out. This voltage is provided as a convenient voltage source for the optically-isolated inputs. This is used, for example when dry contacts (such as a switch) are needed to control the input state. This can be used by connecting the INPUT- directly to the Gnd, and then connecting this terminal to the INPUT+ through a switch. Do not use this output for other purposes. Note that this voltage is active for all models but is only useful for models with 3-12V optical inputs.
Gnd	Negative side of the 5VDC output voltage.
In1+	This is the positive side of the optically-isolated input 1.
In1-	This is the negative side of the optically-isolated input 1.
In2+	This is the positive side of the optically-isolated input 2.
In2-	This is the negative side of the optically-isolated input 2.
1C	Relay 1 Common Contact
1NC	Relay 1 Normally Closed Contact
1NO	Relay 1 Normally Open Contact
2C	Relay 2 Common Contact
2NC	Relay 2 Normally Closed Contact
2NO	Relay 2 Normally Open Contact

### 2.2.1 Power Supply Connection

The WebRelay-Dual™ requires power for its internal logic circuits. Connect appropriate power supply to the Vin+ and Vin- terminals. Alternatively, WebRelay-Dual™ units with the Power Over Ethernet option may be powered through the Ethernet connection instead of using an external power supply.

Multiple WebRelay-Dual™ units may be connected to a single power supply by connecting the power supply input terminals in parallel. The power supply must have a high enough current rating to power all units connected (see **Appendix H: Specifications** for current requirements for specific model numbers).

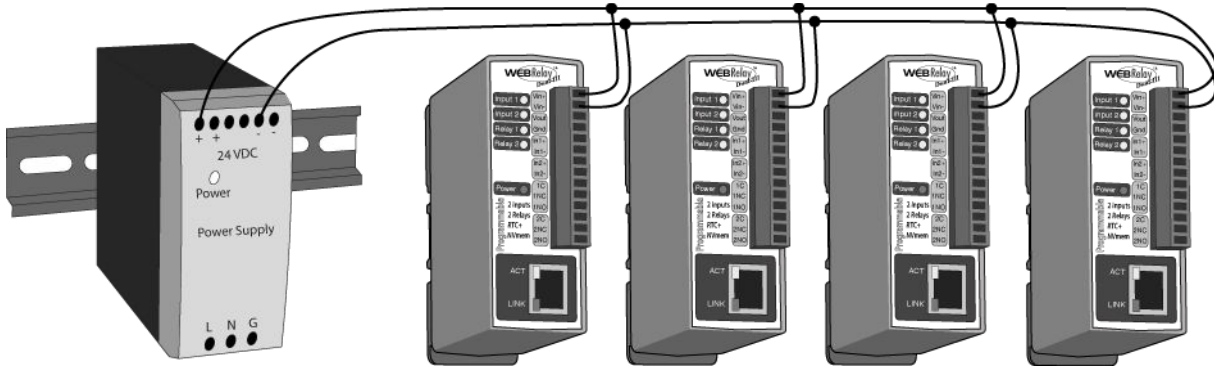

Figure 2.2a—Multiple Unit Power Supply Connection

#### WebRelay-Dual™ -E Models (POE)

WebRelay-Dual™ units with the Power Over Ethernet option may be connected to an 802.3af compliant Ethernet port instead of connecting to an external power supply. In this case, the WebRelay-Dual™ is powered through the network port. In 802.3af compliant networks, a 48 Volt power source is injected into the Ethernet line. This power source is provided by an 802.3af compliant hub, switch, or power injector which may be located in a utility closet which could be a distance away from the WebRelay-Dual™. This option is very useful for installations where local power is not available. The power injector may inject the 48 Volt power source through the data lines or the spare lines in the Ethernet cable.

**DO NOT USE A POWER INJECTOR THAT APPLIES A VOLTAGE TO BOTH THE DATA LINES AND THE SPARE LINES!**

### 2.2.2 Network Connection

Connect the Ethernet port to a 10 Base T or 10/100 Base T Ethernet connection. This typically connects to an Ethernet hub, switch, or router. For configuration, WebRelay-Dual™ may be connected directly to the Ethernet port on a computer using a “crossover” cable. Otherwise, for connection through a hub or router, a standard “straight-through” cable should be used.

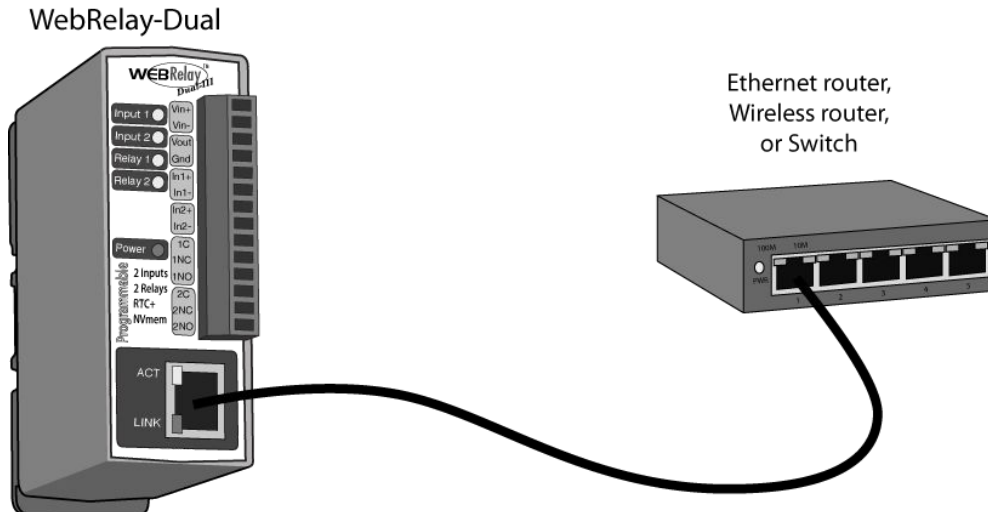

Figure 2.2b—Wired Network Connection

The WebRelay-Dual™ can be used indirectly on a wireless network. This is done by using a wireless Ethernet bridge or a wireless router. The network connection of the WebRelay-Dual™ is connected to the wireless device and the wireless device makes the connection to the wireless network. Note that the wireless Ethernet bridge or router must be properly set up for the wireless network used. Refer to the installation instructions that came with the wireless device.

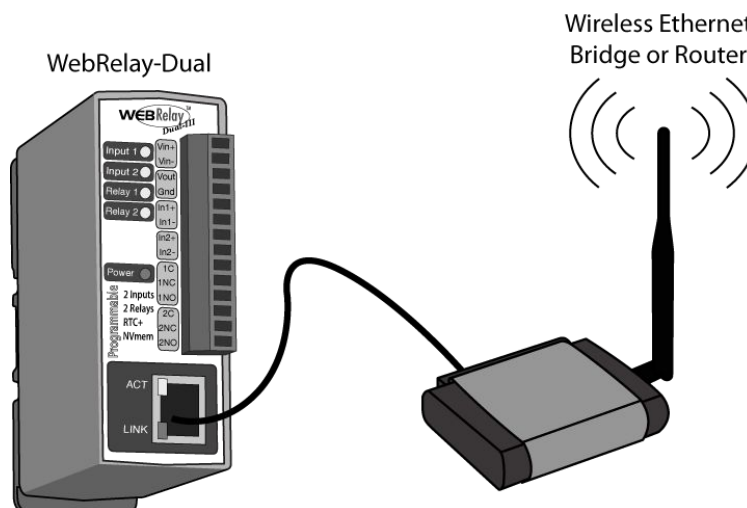

Figure 2.2c—Wireless Network Connection



### 2.2.3 Relay Connection

The relay contacts internally connect directly to the terminal connector. Common, Normally Open, and Normally Closed contacts are provided. The relay contacts may be wired in series with the power source for the load (device to be controlled) as long as the load does not exceed the maximum current and voltage rating of the relay contacts.

For loads greater than 3 Amps, an external relay should be used. The illustration below (Figure 2.2d) shows how a 20-Amp motor can be controlled using an external relay. In the example, the WebRelay-Dual™ controls the external relay and the external relay controls the load.

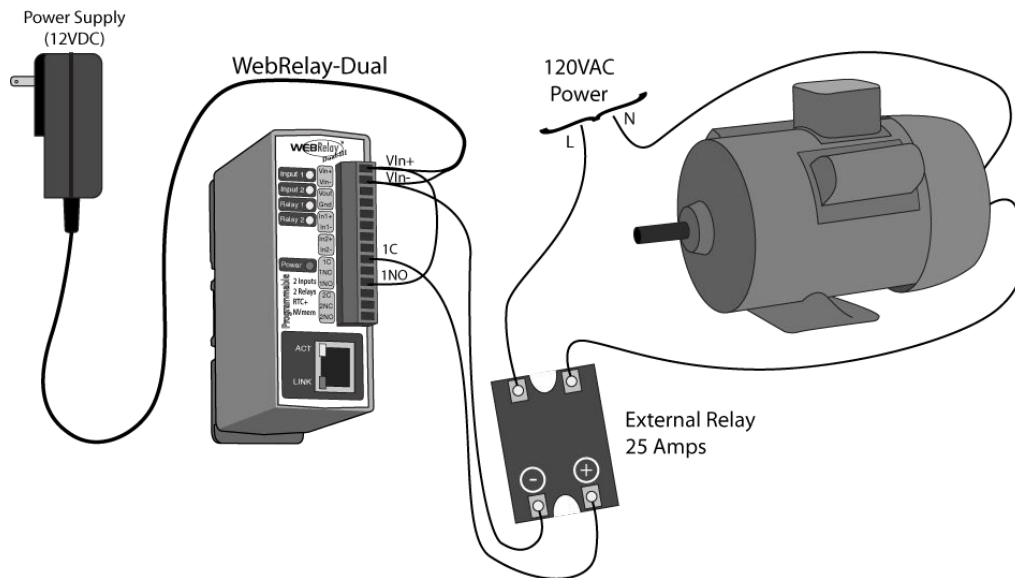

Figure 2.2d—External Relay Connection

When relays switch inductive loads such as motors, transformers, relays, etc., electricity will arc across the internal relay contacts each time the contacts open. Over time, this causes wear on the relay contacts which can shorten their life span. When switching an inductive load, it is recommended that simple relay contact protection devices are used. Note that the WebRelay-Dual™ does not provide relay contact protection in order to provide the greatest versatility and because appropriate protection differs for various loads. Below is an example of relay contact protection for a DC circuit (Figure 2.2e) and an AC circuit (Figure 2.2f). For component values required to provide sufficient contact protection for your application, refer to appropriate references.

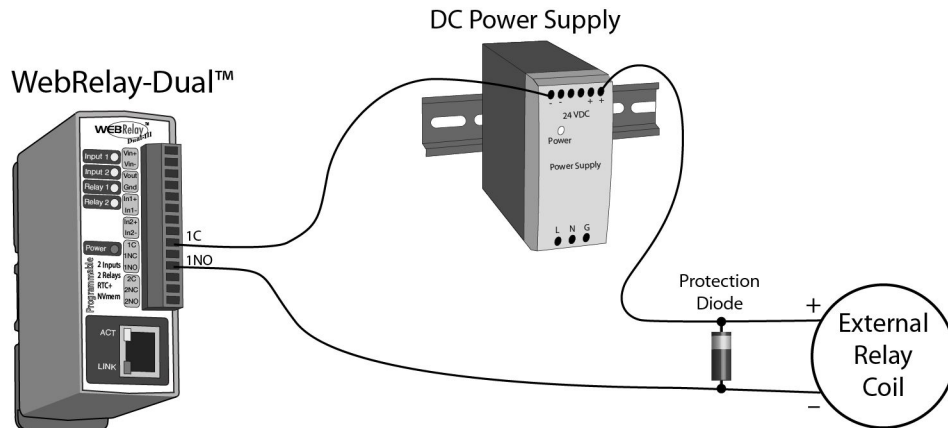

Figure 2.2e—DC Contact Protection

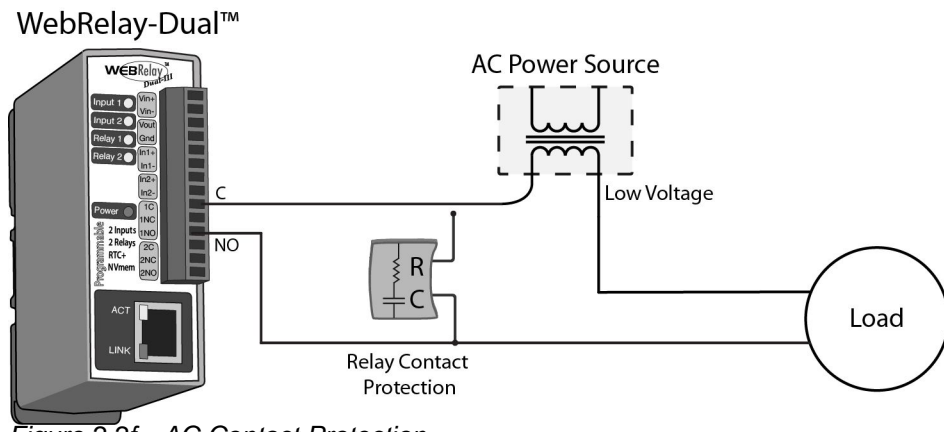

Figure 2.2f—AC Contact Protection

## 2.2.4 Optically-Isolated Input Connections

The optically-isolated inputs can be used to control the internal relays, control remote relays (over the network), or simply to monitor the state of a discrete device. To use these inputs, connect a DC control voltage directly to the input and ground, and set up the function of the input using the configuration pages. A current limiting resistor is provided internally, so no external resistors are required as long as the maximum input voltage is not exceeded. If an AC signal, or a signal greater than the rated input voltage needs to be detected by the WebRelay-Dual™, use a signal conditioner to convert the signal to a DC signal within the input range.

### Connecting "dry contacts" to the optically-isolated inputs:

A dry contact switch can be connected to the input of the WebRelay-Dual™. One side of the contact is connected to +5V OUT, the other side is connected to Input+, and a jumper cable connects the V IN- to the INPUT-. When the contact is closed, it applies 5V to the input terminals.

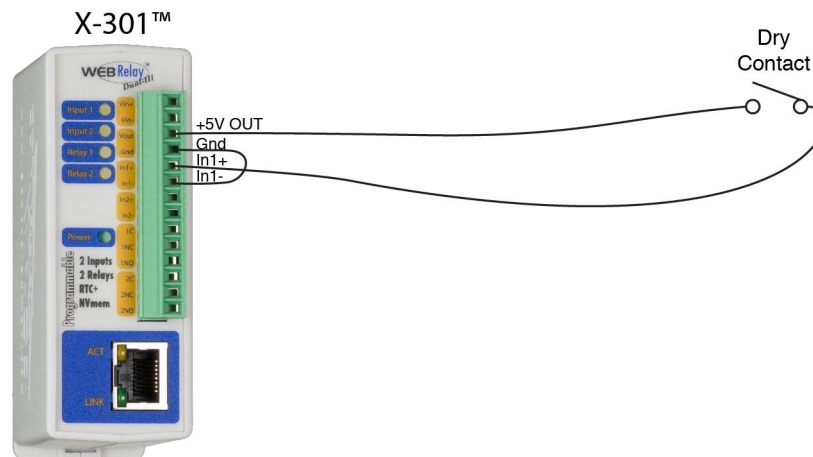

### Connecting voltages to the optically-isolated inputs:

#### AC Inputs:

If an AC signal voltage needs to be detected, use a signal conditioner to convert the AC signal to a DC voltage within the input range. An AC signal conditioner can be made using a diode (or bridge rectifier) and a capacitor. Prepackaged signal converters are available as accessories at industrial automation distributors. A simple voltage converter module manufactured by [www.redlion.net](http://www.redlion.net) is shown below. These are available in two input voltage ranges that cover the spectrum from 4-270VAC/DC. These devices have a MOSFET output (solid state DC contact closure) which is compatible with the WebRelay's input. The converter module accepts AC (50/60 Hz) or DC voltages at input cycles up to 30 Hz. The converter provides isolation between the input and output using an opto-isolator. You must provide a voltage source for the input of the WebRelay as shown in the example below:

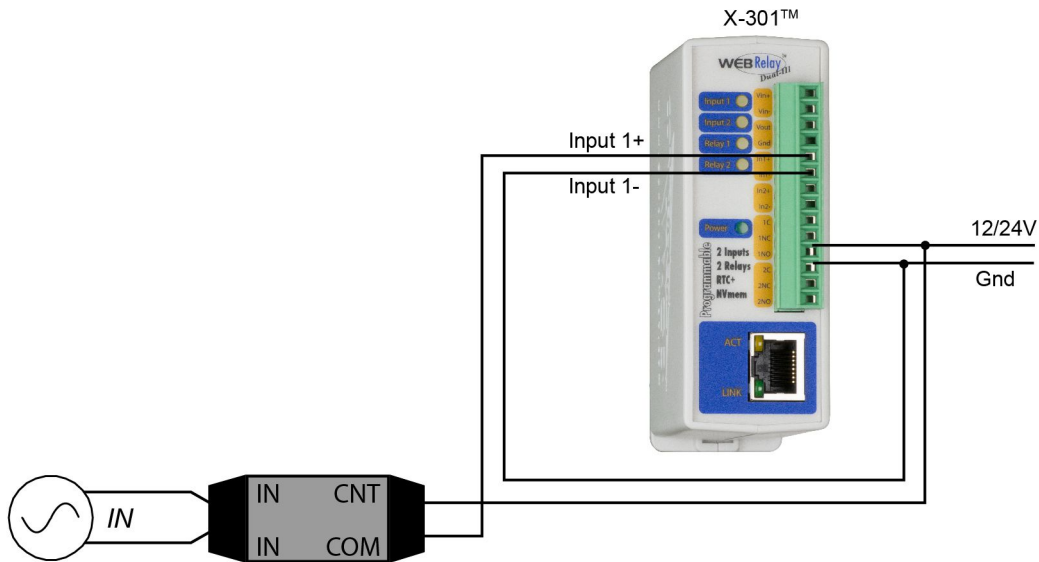

**DC Inputs:**

With DC inputs, no external components are required as long as the maximum input voltage is not exceeded (See Specifications). A DC voltage can be reduced with an external resistor of the appropriate value and power rating to reduce the input current.

The formulas to calculate external resistor values are provided below:

X-301-I and X-301-E models with a **4-12VDC** input range have an internal 680 ohm resistor. The forward voltage drop of the photo-coupler is approximately 1.2V and works well with an input current of 10mA.

$$R = (V_{in} - 1.2) / 0.01 - 680$$

Where:

- *R = External resistor value required*
- *V<sub>in</sub> = Desired input voltage*
- *1.2V = forward voltage drop of the LED in the photo coupler*
- *.01A = workable LED current*
- *680ohm = Internal resistor*

**For example:**

To connect a 24VDC signal voltage to the WebRelay-Dual™ with a 4-12VDC input range:

$$R = ((24 - 1.2) / 0.01) - 680 = 1600 \text{ Ohms (use a 1600 ohm resistor)}$$

Check the power dissipated by the resistor:

$$P = I \times I \times R, \text{ The resistor must be at least } .01 \times .01 \times 1600 = 0.16 \text{ Watts, so use a } 1/2 \text{ Watt resistor}$$

X-301-24I with a **11-26VDC** input range have an internal 3K ohm resistor. The forward voltage drop of the photo-coupler is approximately 1.2V and works well with an input current of 10mA.

$$R = (V_{in} - 1.2) / 0.01 - 3000$$

Where:

- R = External resistor value required
- $V_{in}$  = Desired input voltage
- 1.2V = forward voltage drop of the LED in the photo coupler
- .01A = workable LED current
- 3000ohm = Internal resistor

**For example:**

To connect a 48VDC signal voltage to the WebRelay-Dual™ with a 11-26VDC input range:

$$R = ((48 - 1.2) / 0.01) - 3000 = 1680 \text{ Ohms (use a 1600 ohm resistor)}$$

Check the power dissipated by the resistor:

$P = I \times I \times R$ , The resistor must be at least  $.01 \times .01 \times 1600 = 0.16$  Watts, so use a 1/2 Watt resistor

## 2.3 Establishing Communications for Setup

WebRelay-Dual™ is set up using a web browser. The first task is to establish communications between a computer and the WebRelay-Dual™ device so that the browser-based configuration can begin. To do this, the computer and the WebRelay-Dual™ must be physically connected to the same network and both must have IP addresses on the same network. There are two ways to set up the computer and the WebRelay-Dual™ so that they are on the same network. The first way (Option 1), is to change the IP address of the WebRelay-Dual™ to an address that is on the same network as the computer. The second way (Option 2) is to change the IP address of the computer to an address that is on the same network that the WebRelay-Dual™ is set to by default.

### 2.3.1 Option 1: Assign a temporary IP address to WebRelay-Dual™

This option is used to TEMPORARILY assign an IP address to the WebRelay-Dual™ without the need to change the IP address of the configuration computer. Note that the WebRelay-Dual™ will only use this IP address as long as power is maintained. Once power is lost and restored, the WebRelay-Dual™ will use the IP address assigned in the setup page and not the temporary address assigned here. This means that once communications are established, the desired IP address should be entered into the **Network** setup tab using the browser.

#### To assign the temporary IP address...

1. Make sure the WebRelay-Dual™ and the configuration computer are connected to the same physical network. This will not work through routers or gateways.
2. Assign the address as follows:

#### Windows:

Open a Command Prompt (select START, then RUN, then type "cmd").

Note: for Vista, the Command Prompt should be run as administrator (select Start, then type "cmd" and right click on "cmd" and select "Run as administrator").

Type:

```
arp -s {new IP address} {serial number of the WebRelay-Dual™ }
```

Note: IP address format is xxx.xxx.xxx.xxx

Serial number format is ss-ss-ss-ss-ss-ss

For example, to set a WebRelay-Dual™ (with serial number 00-0C-C8-01-00-01) to 10.10.10.40 the following command would be used:

```
arp -s 10.10.10.40 00-0c-c8-01-00-01
```

Next, type:

```
ping -l 102 {new IP address}
```

For example, if the new IP address is 10.10.10.40, the following command would be used:

```
ping -l 102 10.10.10.40
```

#### Linux/Unix:

Open a terminal, change to root user (su -, then enter root password).

Type:

```
arp -s {new IP address} {serial number of the WebRelay-Dual™ }
```

Note: IP address format is xxx.xxx.xxx.xxx  
Serial number format is ss:ss:ss:ss:ss:ss

For example, to set the WebRelay-Dual™ (with serial number 00-0C-C8-01-00-01) to 10.10.10.40 the following command would be used:

```
arp -s 10.10.10.40 00:0c:c8:01:00:01
```

Next, type:

```
ping -s 102 {new IP address}
```

For example, if the new IP address is 10.10.10.40, the following command would be used:

```
ping -s 102 10.10.10.40
```

Mac OS X:

Open a terminal.

Note that the terminal is in the “Utilities” directory, which is in the “Applications” directory.

Type:

```
sudo arp -s {new IP address} {serial number of the WebRelay-Dual™ }
```

Note: Administrator password is required.  
IP address format is xxx.xxx.xxx.xxx  
Serial number format is ss:ss:ss:ss:ss:ss

For example, to set a WebRelay-Dual™ (with serial number 00-0C-C8-01-00-01) to 10.10.10.40 the following command would be used:

```
sudo arp -s 10.10.10.40 00:0c:c8:01:00:01
```

Next, type:

```
ping -s 102 {new IP address}
```

For example, if the new IP address is 10.10.10.40, the following command would be used:

```
ping -s 102 10.10.10.40
```

### 2.3.2 Option 2: Assign a temporary IP address to configuration computer

If the first option above is not used, you can use this option to communicate with the WebRelay-Dual™. By default, the WebRelay-Dual™ comes from the factory with an IP address of 192.168.1.2. Communications with the WebRelay-Dual™ may be established by assigning an IP address to the configuration computer that is on the same network as the WebRelay-Dual™ (for example, the configuration computer could be assigned to 192.168.1.50).

Instructions for changing the IP address of the computer that will be used for the WebRelay-Dual™ configuration are given here. The following example is for those running the Windows operating system. For setup using other operating systems, refer to the appropriate users manual.

#### Step 1:

Open the control panel by clicking on the start menu and then clicking on Control Panel (Figure 2.3a). (Note that the control panel shown (Figure 2.3b) is in “Classic View.” If the control panel is in “Category View,” select the “Classic View” option before proceeding.)



Figure 2.3a—Start Menu

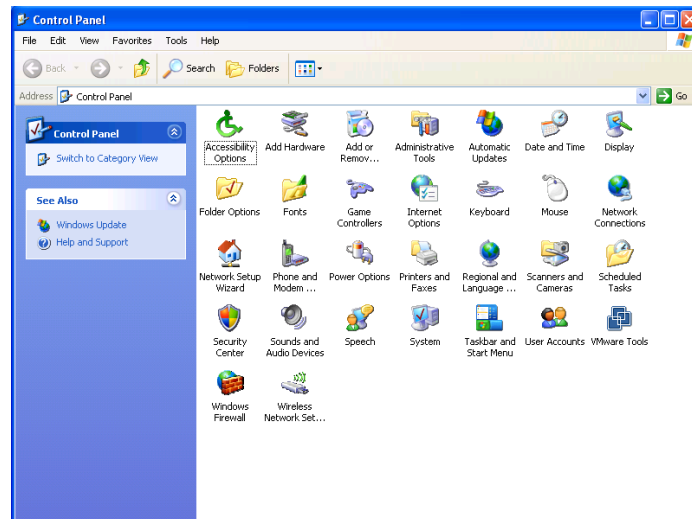

Figure 2.3b—Control Panel

#### Step 2:

Double click on the icon labeled Network Connections. The following window will pop up (Figure 2.3c).



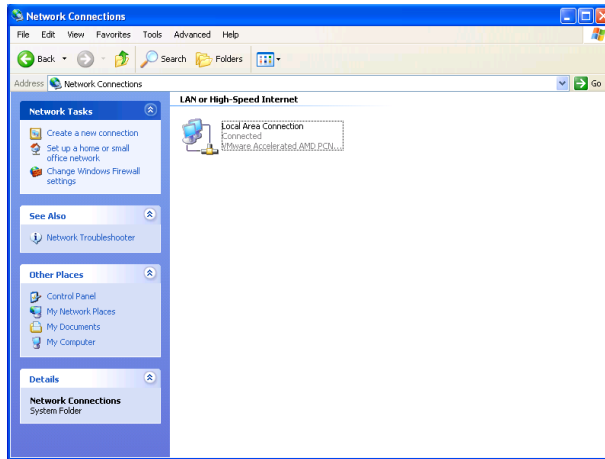

Figure 2.3c—Network Connection

*Note: To access the Network Connections folder in Windows Vista, select the Windows Icon (Start Menu) and enter ncpa.cpl into the search bar and press Enter (see Figure 2.3d).*



Figure 2.3d—Vista Network Connection

**Step 3:**

Right click on the icon labeled Local Area Connection. In the menu that follows, select the option at the bottom of the menu labeled Properties. The Local Area Connection Properties window will appear. Scroll down to and highlight "Internet Protocol (TCP/IP)," then click the button labeled "Properties." (Figure 2.3e)

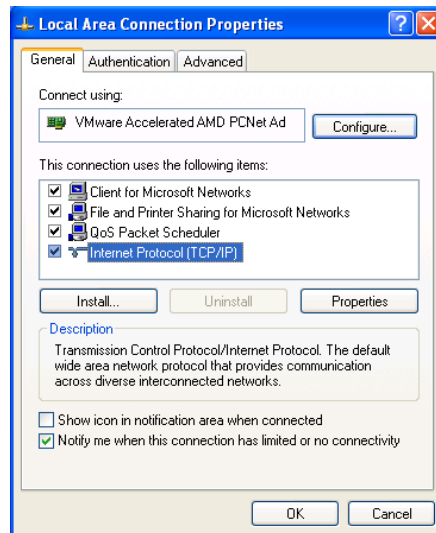

Figure 2.3e—Local Area Connection

**Step 4:**

The following "Internet Protocol (TCP/IP)" Properties menu appears:

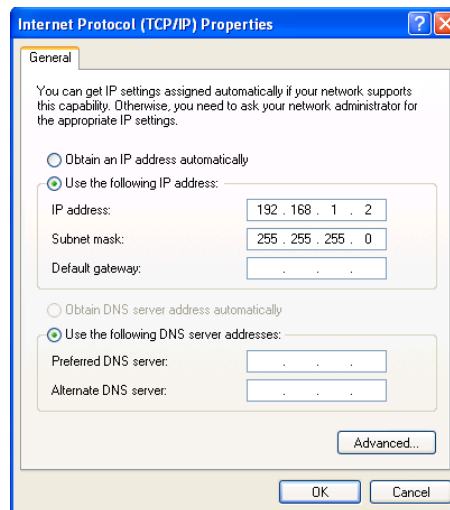

Figure 2.3f—TCP/IP Properties

*Note: Before making any changes to the network settings (Figure 2.3f), write down the current settings so that they can be restored once the WebRelay-Dual™ is configured.*

**Step 5:**

Select the radio button labeled "Use the following IP address" and type in the IP address 192.168.1.50. Type in a subnet mask of 255.255.255.0. Leave the default gateway field blank. Click OK to accept the new settings.

**2.3.3 Open Configuration Web Page**

Once the network is set up, open the setup page as described in section 2.4. If the setup pages are not accessible, verify that the WebRelay-Dual™ is powered on and that the LINK light is illuminated. Check all network connections and settings. Another way to check communications is to ping the WebRelay-Dual™ (from the command prompt by typing ping {X-300 IP address} ).

## 2.4 WebRelay-Dual™ Setup Pages

The WebRelay-Dual™ is configured using a web browser. To access the setup pages, enter the following URL in the address bar of a web browser:

```
http://{ipaddress}/setup.html
```

For example, using the default IP address, enter:

```
http://192.168.1.2/setup.html
```

After the page is requested, a password prompt will appear. Enter the user name and password. Note that the default user name is admin and the default password is webrelay (password is case sensitive).

### 2.4.1 Main Tab

This is the initial page that is displayed when setup.html is entered into the address bar of the browser. It displays model and serial number information, and basic diagnostic information about the WebRelay-Dual™ unit.

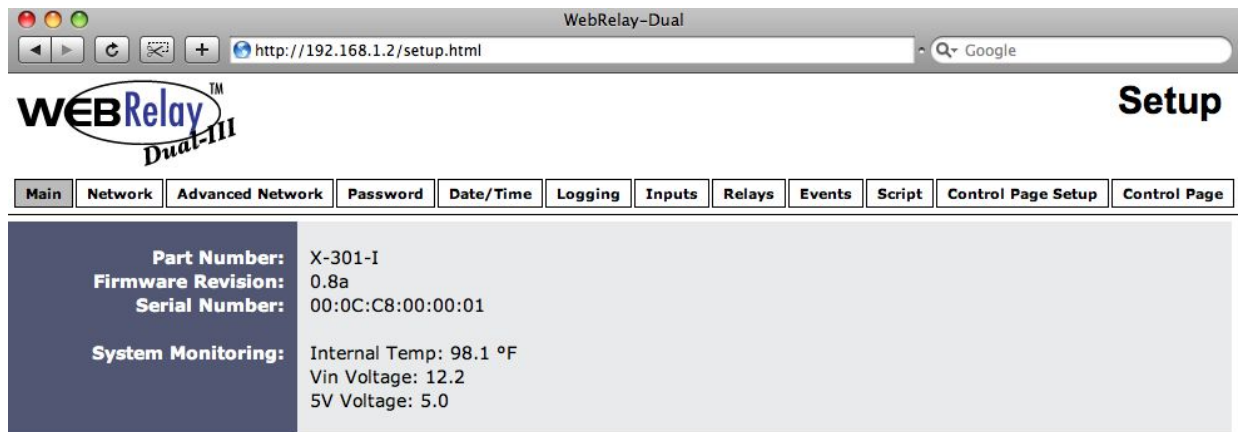

For product support go to [www.ControlByWeb.com](http://www.ControlByWeb.com)  
Xytronix Research & Design, Inc.

Figure 2.4a—Main Tab

#### **Part Number**

This is the full model number of the WebRelay-Dual™.

#### **Firmware Revision**

This is the current product revision of the unit's firmware.

#### **Serial Number**

This is the serial number of this unit. The serial number is also the MAC address of the unit.

### **System Monitoring**

Internal Temp: This displays the current temperature inside the WebRelay-Dual™. Note that it is normal for this to be significantly higher than room temperature.

Vin Voltage: This is the DC voltage that is applied to the VIn+ and VIn- terminals.

5V Voltage: Internally, the unit operates on a 5V DC power supply. This field is used to view current value.

*Note: The values in these fields are only updated when the web page is refreshed.*

### 2.4.2 Network Tab

The network parameters are set on this page. Note that if multiple ControlByWeb™ products are used on the same network, install one at a time and set the IP address of each unit before connecting the next unit to the network. This avoids having multiple devices being installed on the network with the same factory default IP address at the same time. It may be necessary to clear the 'arp' cache each time you swap ControlByWeb™ products on the network (this is because each unit has the same default IP address, but a different MAC address). This is done by typing "arp -d" in the command prompt of a Windows computer ("sudo arp -d -a" as a super user in the terminal of Mac OS X).

*Note that the WebRelay-Dual™ must be power-cycled (power disconnected, then reconnected) before network settings take effect. Only the settings on the **Network** tab require power-cycling before taking effect.*

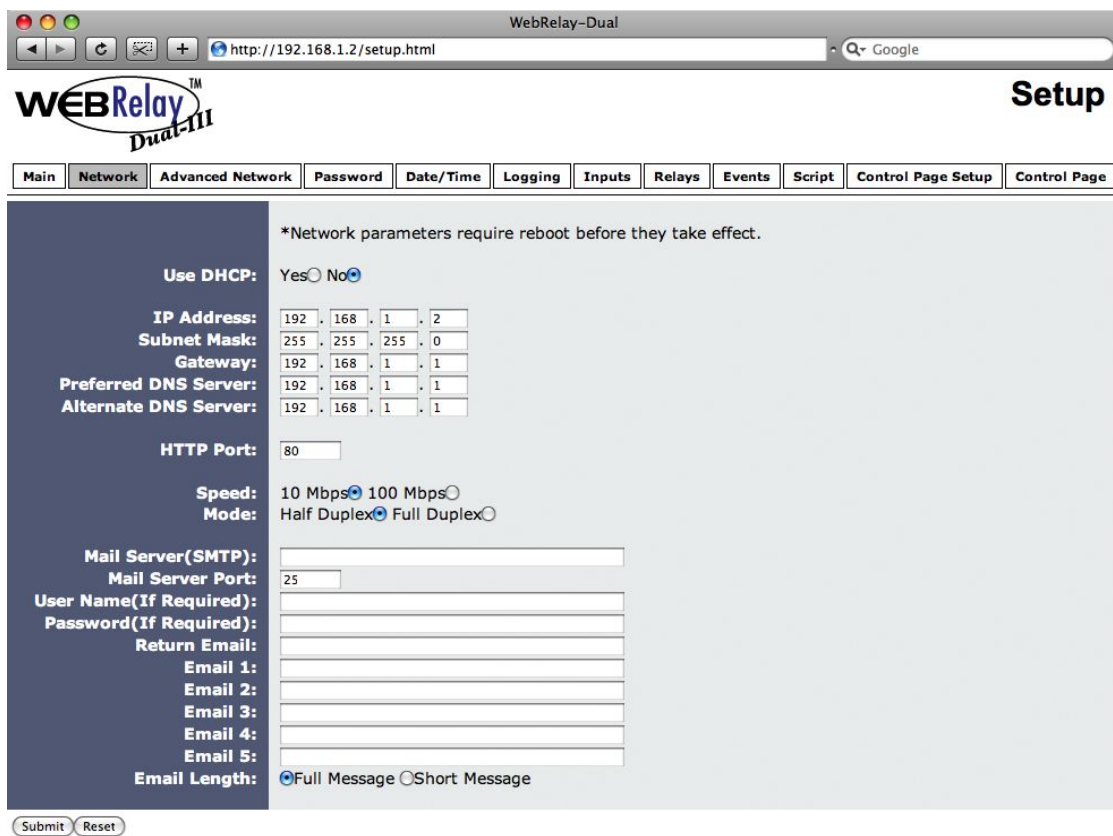

Figure 2.4b—Network Tab

#### Use DHCP

This option allows DHCP to be enabled or disabled. If this option is set to **Yes**, the WebRelay-Dual™ will wait for an IP address from a DHCP server each time it is powered. The default setting is **No** (this is recommended for most installations). If DHCP is set to **Yes**, the Network page must be submitted and the WebRelay-Dual™ must be rebooted before an IP address will be assigned. Once the WebRelay-Dual™ is assigned an IP address by the DHCP, the new IP address can be found through the clients list kept by the DHCP server. For most instances, this is found on the local gateway or router. (See **Brief Notes About DHCP** at the end of this section for more information.)

**IP Address**

Enter the IP address for the WebRelay-Dual™ in this field. The IP address is specific to the network where the WebRelay-Dual™ will be installed, and must be obtained from the network administrator. For more information on IP addresses and remotely accessing the WebRelay-Dual™ over the Internet, see **Appendix C: Accessing WebRelay-Dual™ Over the Internet**. The default setting for this field is 192.168.1.2.

**Subnet Mask**

The subnet mask defines the size of the local network. This must be obtained from the network administrator. For additional information about sub-netting and IP networking, many tutorials are available on the Internet. The default setting for this field is 255.255.255.0.

**Gateway**

This specifies the IP address of the gateway router. This must be obtained from the network administrator. The default setting for this field is 192.168.1.1.

**Preferred DNS Server**

The IP address of the Primary DNS server is specified here. When DNS services are required, this is the address that will be used. The default setting for this field is 192.168.1.1.

This field is only required when the following options are used:

- **Remote Services** (when server is specified by name and not IP address).
- **Sync time clock with remote NTP server** (when server name is specified by name and not IP address).
- **Mail Server is used** (when server name is specified by name and not IP address).

**Alternate DNS Server**

This field is used to specify the IP address of a Secondary DNS server. This is used when the WebRelay-Dual™ requires DNS services and the preferred DNS server is not available. The default setting for this field is 192.168.1.1.

**HTTP Port**

The TCP port used for HTTP communications (web browser, xml, get commands) with the WebRelay-Dual™ is specified here. It is recommended that the port not be changed without an understanding of TCP/IP and ports. For more information on TCP ports and IP addressing see **Appendix C: Accessing WebRelay-Dual™ Over the Internet**. The default setting for this field is 80, which is the standard HTTP port.

**Speed**

This option sets the data rate (clock rate) of the Ethernet port. Either **10Mbps** or **100Mbps** can be selected. The 100Mbps option offers faster communications but the amount of data to and from the WebRelay-Dual™ is so small that users will not likely notice much (if any) difference. When the WebRelay-Dual™ is set to **10Mbps**, it draws less power and runs a little cooler which translates into a longer product life. IT IS RECOMMENDED THAT THIS SETTING BE LEFT AT **10Mbps** UNLESS THE USER HAS A SPECIFIC REASON TO USE **100Mbps**. The default setting for this field is **10Mbps**.

**Mode**

This option allows the Ethernet port to be set to **Half Duplex** or **Full Duplex**. Legacy Ethernet operates in Half Duplex mode which means that devices can either send data or receive data, but not both at the same time. Full Duplex means that devices can send and receive data at the same time. The default setting for this field is **Half Duplex**.

The remaining fields on the **Network** tab are required only if the WebRelay-Dual™ is configured to send email messages when alarm conditions occur.

**Mail Server (SMTP)**

The name of the mail server (for example mail.example.com) or the IP address of the mail server (for example 192.10.10.10) should be entered in this field. Note that if the server name is entered and not the IP address, the address of a DNS server will be required. There is no default setting for this field.

**Mail Server Port**

The standard port for SMTP is 25, however an alternate port may be entered here. The default setting for this field is 25.

**User Name (If Required)**

If the SMTP mail server requires authentication, the user name must be entered here. There is no default setting for this field.

**Password (If Required)**

If the SMTP mail server requires authentication, the password must be entered here. There is no default setting for this field.

**Return Email**

The WebRelay-Dual™ will not receive email messages, but when the WebRelay-Dual™ sends email messages, it must include a return email address. This field is used to specify the return email address. Note that although the WebRelay-Dual™ will send email messages with any email address specified in this field, some email filters (spam filters) will not allow messages through that include an invalid email address. There is no default setting for this field.

**Email 1 to Email 5**

Enter the email address of up to five recipients for alarm messages in these fields. There are no default settings for these fields. Up to 40 characters may be entered in this field.

**Email Length**

Choose either "full" or "short" email lengths. When "full" is selected, all visible fields in the control page will be included in the email message to be sent out; however if "short" is selected, the email content will only be a brief description of what triggered the email message.



**MTU Setting**

To change the MTU, manually enter the advSetup.html (case sensitive) page into the address bar. (<http://192.168.1.2/advSetup.html>). This new setup page will have a text box that will allow the MTU to be changed. The valid range is 256 to 1476 bytes. MTU is a network parameter that stands for Maximum Transmission Unit. This defines the max size, in bytes, of the TCP packets sent out from the device. This normally can be left alone, but there are some circumstances where it might be beneficial to change it. One of these circumstances is when the device is to be used over a VPN (virtual private network). VPN's add extra information to TCP packets, if the new packets are too big to physically travel across the network (greater than about 1500 bytes) then the packets will be split up. This causes problems for some firewalls and those firewalls will just discard the packets. To fix this, the MTU can be adjusted until the TCP packets do not get split up.

**Brief Notes About DHCP**

All devices on an IP network require an IP address. This is a unique address that identifies each device on the network. DHCP (Dynamic Host Control Protocol) is a mechanism that automatically assigns an IP address to a computer (or other devices) when it is connected to a network. This eliminates the need to manually enter the IP address. When a computer is connected to the network, another device on the network called a DHCP server detects the presence of the computer and dynamically assigns the IP address to that computer. On many small networks, the DHCP server is built into the router.

DHCP works well for "client" devices such as computers, but is not ideal for servers. This is because servers usually don't initiate communications with other devices, but rather they wait for a request from "clients." To make this request, the client must know the IP address of the server. If a server gets its IP address dynamically, the IP address may not always be the same so client devices may not be able to find the server. For this reason, servers usually use an IP address that is fixed and does not change. The WebRelay-Dual™ is a server and manual IP address assignment is usually recommended.

### 2.4.3 Advanced Network Tab

Note that these settings are not used for most installations. Also note that some settings on this tab require the unit to be power-cycled (power disconnected, then reconnected before taking effect).

The screenshot shows the 'Advanced Network' tab in the WebRelay-Dual™ setup interface. The browser address bar shows 'http://192.168.1.2/setup.html'. The page title is 'WebRelay-Dual™ Setup'. The navigation menu includes: Main, Network, **Advanced Network**, Password, Date/Time, Logging, Inputs, Relays, Events, Script, Control Page Setup, and Control Page.

**Modbus Enabled:** Yes  No

**Modbus Port:** 502

**Remote Services Enabled:** Yes  No

**Server Name/IP Address:** [Empty text box]

**Server Port:** 8000

**Connection String:** [00:0C:C8:00:00:01]:ControlByWeb,X-301

**Connection Interval:** 1 Minutes

**SNMP Enabled:** Yes  No

**SNMP Manager IP:** 192 . 168 . 1 . 25

**SNMP Port:** 161

**SNMP Trap Port:** 162

**IP Filter Range 1:** 0 . 0 . 0 . 0  
255 . 255 . 255 . 255

**IP Filter Range 2:** 0 . 0 . 0 . 0  
0 . 0 . 0 . 0

Buttons: Submit, Reset

Figure 2.4c—Advanced Network Tab

#### **Modbus Enabled**

The WebRelay-Dual™ can support Modbus/TCP. For users not familiar with Modbus, Modbus is a messaging structure protocol used in industrial manufacturing control and automation. It is an open protocol and offers interoperability with software and devices from other manufacturers. This is enabled by selecting Yes in this field. Note that Modbus communications are disabled whenever the control password is enabled. The default setting for this field is No.

#### **Modbus Port**

This specifies the port used for Modbus/TCP communications with the WebRelay-Dual™. By default this is set to port 502 which is the standard Modbus port. It can be set within the range of 0 to 65535. The unit must be power-cycled before the new port number takes effect.

#### **Remote Services Enabled**

This option enables or disables Remote Services. If **Yes** is selected, Remote Services will be enabled as soon as the submit button is pressed and the WebRelay-Dual™ will immediately attempt to make a connection with the remote server (power cycle not required). Once a connection is established, the connection will remain until it is disconnected by the remote server. Proper connection with the remote server can be verified by viewing the system status log file (see **Appendix D: Log Files**). The default setting for this field is **No**. Most users should leave this setting at its default. (See **Remote Services** at the end of this section for more information.)

**Server Name/IP Address**

Specify the name or IP address of the Remote Services server here. If the IP address is specified, enter it as aaa.bbb.ccc.ddd. For numbers that are less than 100, preceding zeros should not be included (for example, enter 80 rather than 080). This field can be up to 40 characters long and has no default setting.

**Server Port**

Enter the TCP port used for the Remote Services server. This can be set within the range of 0-65535. The default setting for this field is 8000.

**Connection String**

This text is sent to the Remote Services server when the connection is established. This string should include any information required by the server at connection. For example, it may include an ID number, customer number, password, etc. The format is entirely dependent upon the server requirements. This field can be up to 80 characters long. Default text is provided only as an example placeholder. The default text is [`<serialAddress>`]:ControlByWeb,X-301.

**Connection Interval**

This field specifies the periodic interval in which the WebRelay-Dual™ attempts to connect to the remote server, or if the WebRelay-Dual™ is already connected, it is the interval in which the WebRelay-Dual™ sends the connection string. This field can be set within the range of 1 to 34452 minutes. The default setting for this field is 1 minute.

**SNMP Enabled**

When this option is set to **Yes**, the WebRelay-Dual™ will support SNMP. The default setting for this option is **No**. (See **SNMP** at the end of this section for more information.)

**SNMP Manager IP**

When SNMP is used, this field is used to specify the IP address of the SNMP manager. The default setting for this field is 192.168.1.25.

**SNMP Port**

When SNMP is used, this field is used to specify the SNMP port that the WebRelay-Dual™ listens on. The default setting for this field is 161.

**SNMP Trap Port**

When SNMP is used, this field is used to specify the SNMP Trap port of the SNMP manager. The default setting for this field is 162.

**IP Filter Range**

For additional security, the WebRelay-Dual™ has a simple built-in firewall. If desired, the WebRelay-Dual™ can be configured to only allow access to client devices (computers, servers, other ControlByWeb™ devices, etc) with certain IP addresses. Two IP address ranges are provided and only client devices with addresses that fall within those two ranges will be allowed to communicate. Devices with IP address that fall outside of those ranges will not receive any response from the WebRelay-Dual™.

To allow access from any device (this is the default setting):

IP Filter Range 1: 0.0.0.0  
255.255.255.255  
IP Filter Range 2: 0.0.0.0  
0.0.0.0

To limit access to only one device (address 192.168.1.33):

IP Filter Range 1: 192.168.1.33  
192.168.1.33  
IP Filter Range 2: 0.0.0.0  
0.0.0.0

To limit access to only devices on the local network and one device on the internet (address 10.143.100.32):

IP Filter Range 1: 192.168.1.0  
192.168.1.255  
IP Filter Range 2: 10.143.100.32  
10.143.100.32

**Note:** The address specified for the Remote Services server (if applicable) is automatically allowed through the firewall no matter how the filter is set.

## Remote Services

Remote Services initiates an outgoing connection to a server at a remote location. This can be used, for example in an environment where a web server on the Internet provides a custom user interface and users access the WebRelay-Dual™ through the web server rather than communicating directly with the WebRelay-Dual™. This is sometimes referred to as “web services”.

As mentioned earlier in this users manual, using an external web server allows users to access one or many WebRelay-Dual™ units (or other ControlByWeb™ products) through a custom web page. This has the benefits of being able to combine multiple devices seamlessly into a single web page, and it allows programmers to create powerful, custom web pages using the web programming languages of their choice.

Using the Remote Services configuration so that the WebRelay-Dual™ units initiate the connection to the external web server (rather than having the web server initiate communications to the WebRelay-Dual™ units) has two main benefits. First, the web server does not need to know the IP address of the WebRelay-Dual™. This means that the WebRelay-Dual™ can get its IP address dynamically from a DHCP server which simplifies the installation. Second, since the connection from the WebRelay-Dual™ is outgoing, rather than incoming, the local router on the network where the WebRelay-Dual™ resides doesn't need to be configured to forward sockets. This also has the benefit of simplifying the installation. In addition, since the router configuration is not modified, the risk of compromising security on the local network is eliminated. For more information about the Remote Services see **Appendix E: External Server and Remote Services**.

## SNMP

Simple Network Management Protocol (SNMP) is used to manage and administer network devices. WebRelay-Dual™ supports SNMP V1.0 and can be configured here. Using SNMP, the input and relay states of the WebRelay-Dual™ can be read as well as some basic information about the device. See **Appendix F: SNMP Requests** for information about how to request information from the WebRelay-Dual™ using an SNMP manager, as well as where to find MIB files for the WebRelay-Dual™.

*Note: The read and write community strings used for SNMP are actually the control password found on the **Password** setup tab (see Section 2.5.4). If the control password is disabled, then the WebRelay-Dual™ does not check for the community string when issued a Get or Get Next request from the SNMP manager. The WebRelay-Dual™ always requires the write community string when issued a Set request.*

## 2.4.4 Password Tab

The WebRelay-Dual™ requires a password to log into the setup pages. The password can be changed on this page. Additionally, the installer can enable the requirement for a control password.

The screenshot shows a web browser window titled "WebRelay-Dual" with the address bar displaying "http://192.168.1.2/setup.html". The page header includes the "WEBRelay™ Dual-III" logo and the word "Setup". A navigation menu contains tabs for "Main", "Network", "Advanced Network", "Password", "Date/Time", "Logging", "Inputs", "Relays", "Events", "Script", "Control Page Setup", and "Control Page". The "Password" tab is active. The form contains the following fields:

- Setup Password: [password field]
- Re-enter Setup Password: [password field]
- Enable Control Password: Yes  No
- Control Password: [password field]
- Re-enter Control Password: [password field]

At the bottom of the form are "Submit" and "Reset" buttons.

Figure 2.4d—Password Tab

### Setup Password

The setup password, which is required to access the setup pages can be modified by entering a new password here. Passwords that are 8 characters or longer (up to 13 characters can be entered in this field) with both alphabetic and numeric characters are recommended. For security purposes, the password will not be displayed as it is entered. Note that the user name required for accessing the setup pages is admin (all lower case). The default setup password is webrelay (also all lower case).

### Re-enter Setup Password

When the setup password is changed, it must be entered twice. One time in the previous field and a second time in this field. If the password is not entered identically in both fields, the password will not be changed.

### Enable Control Password

The **Control Page** can be viewed without entering a password. For security purposes, a password can be required for access to the **Control Page**. When this field is set to **Yes**, a password will be required to view the **Control Page**. The default setting for this field is **No**.

### Control Password

When the Enable Control Password option above is set to Yes, this field is used to specify the password which will be required to access the **Control Page**. Passwords that are 8 characters or longer with both alphabetic and numeric characters are recommended. For security purposes, the password will not be displayed as it is entered. Note that the WebRelay-Dual™ requires a password, but does not require a user name to access the **Control Page**. However, some browsers require a user name to be entered. In this instance enter none as the user name. The default control password is webrelay.

### Re-enter Control Password

When the control password is changed, it must be entered twice. One time in the previous field, and a second time in this field. If the password is not entered identically in both fields, the password will not be changed.

## 2.4.5 Date/Time Tab

The WebRelay-Dual™ uses the time for scheduled events, such as turning the relays on or off at scheduled times and for logging (a time stamp is included with each logged event). The time is stored and displayed in 24-hour time format. The WebRelay-Dual™ has a capacitor-backed real-time-clock circuit that will keep track of time for several days in the event of a power failure.

### Current Date/Time

This is the current date and time stored in the WebRelay-Dual™. The time is stored and displayed in 24-hour format.

### Set Time

This drop-down list offers two options: **Manually** and **Sync with NTP server**. For each of the two options, the options below this field change.

- **Manually** is selected when the user needs to manually enter the time and date. When this option is selected, parameters 3 & 4 appear.
- **Sync with NTP server** allows the user to set the clock automatically by using an NTP (Network Time Protocol) server. Many NTP servers are available for use on the Internet. In addition, many desktop computers will function as an NTP server (both Mac and PC). Note that if a desktop computer is used, firewall settings may need to be adjusted allowing for NTP communications (port 123). When this option is selected parameters 5-8 appear.

The screenshot shows the 'Date/Time' tab in the WebRelay-Dual setup interface. The browser address bar shows 'http://192.168.1.2/setup.html'. The page title is 'Setup'. A navigation menu includes 'Main', 'Network', 'Advanced Network', 'Password', 'Date/Time', 'Logging', 'Inputs', 'Relays', 'Events', 'Script', 'Control Page Setup', and 'Control Page'. The 'Date/Time' section contains the following fields:

- Current Date/Time:** Thu, 19 Nov 2009 13:34:55
- Set Time:** Manually (dropdown menu)
- Date:** A calendar for January 2009. The 1st is highlighted.
- Time (24 Hour Format):** 00 : 00 : 00
- Daylight Savings:** Yes (radio button selected), No (radio button)
- Daylight Savings Start:** 2nd (dropdown), Sun (dropdown), Mar (dropdown)
- Daylight Savings End:** 1st (dropdown), Sun (dropdown), Nov (dropdown)

At the bottom of the form are 'Submit' and 'Reset' buttons.

Figure 2.4e - Date/Time Tab-Manual

The following parameters (3-4) are available when the Set Time is set to **Manually**

### Date

This field is used to enter the current date. The date is entered by first selecting the correct month and year by using the left and right arrows at the top of the calendar. The single arrows (< and >) change the month and the double arrows (<< and >>) change the year. Once the current month and year are displayed, the date should be entered by moving the mouse pointer over the correct day and clicking the (left) mouse button to highlight that date.

## Time

Enter the time as HH:MM:SS (HH represents hours in 24-hour format (00-23), MM represents minutes (00-59), SS represents seconds (00-59)).

The screenshot shows a web browser window titled "WebRelay-Dual" with the URL "http://192.168.1.2/setup.html". The page features the "WEBRelay Dual-III" logo and a "Setup" header. A navigation menu includes tabs for Main, Network, Advanced Network, Password, Date/Time (selected), Logging, Inputs, Relays, Events, Script, Control Page Setup, and Control Page. The "Date/Time" tab is active, displaying the following settings:

- Current Date/Time:** Thu, 01 Jan 1970 00:49:22
- Set Time:** Sync with NTP server (dropdown menu)
- Server Name/IP Address:** (text input field)
- Sync With Server:** Once  Daily  Weekly  Monthly
- Sync On Power Up:** Yes  No
- UTC Offset:** -7
- Daylight Savings:** Yes  No
- Daylight Savings Start:** 2nd Sun Mar
- Daylight Savings End:** 1st Sun Nov

At the bottom of the form are "Submit" and "Reset" buttons.

Figure 2.4f—Date/Time Tab—NTP Server Synchronization

The following parameters (5-8) are available when Set Time is set to *Sync with NTP server*

### Server Name/IP Address

This field is used to specify the name or IP address of the NTP server. If a name is specified, a working DNS server address must be entered into the **Network** settings. If the IP address is specified, it should be entered in the following format `aaa.bbb.ccc.ddd` where each of the numbers represents a number between 0 and 255. This field can be up to 40 characters. There is no default value for this field.

### Sync With Server

This option allows the user to specify how often the the WebRelay-Dual™ time will be synchronized with the time server. When the submit button on this page is pressed, the The WebRelay-Dual™ will immediately synchronize with the time server. If **Daily**, **Weekly**, or **Monthly** options are selected, the WebRelay-Dual™ will thereafter re-synchronize with the time server at 12:02 AM at the period interval specified. The default value of this setting is **Once**.

### Sync on Power Up

When this option is set to **Yes**, WebRelay-Dual™ will be synchronized with the time server each time it is powered. Note that if it is expected that the WebRelay-Dual™ will lose power on a frequent basis, it may be beneficial to set this option to **No**; some time servers are configured to dis-allow access from client devices that excessively request their services. The default value of this setting is **No**.



**UTC Offset**

Time servers return the current time in Universal Time (GMT). It is common for many servers and data loggers to use GMT as their official time, even when they are not located within the GMT time zone. The default value for this field is -7 (Mountain Standard Time).

For convenience, the time can be converted to local standard time by entering the offset here. This manual cannot include the UTC Offset for all parts of the world, but the offset for GMT time and the four major US Time zones are listed here.

GMT Time: 0  
Eastern Standard Time: -5  
Central Standard Time: -6  
Mountain Standard Time: -7  
Pacific Standard Time: -8

**Daylight Savings**

In many parts of the United States and in some other countries, the time is shifted forward by one hour during the summer months. This is an effort to conserve energy by making the daylight last longer into the evening hours. If this option is set to **Yes**, the time on the WebRelay-Dual™ will automatically be shifted forward by one hour between the hours of 12:00 AM – 5:00 PM on the Daylight Savings Start date set below, and it will shift back to standard time between the hours of 12:00 AM – 5:00 PM on the Daylight Savings End date set below. The time change is made at a random time within the previously mentioned, five-hour time frame, in order to prevent several different devices from simultaneously requesting a time and overwhelming the NTP server. The default setting is **Yes**.

Please note that by enabling the daylight savings time adjustment, scheduled events will be adjusted for the new time. Also note that logged data includes a time stamp based upon the current time in the device so it is possible to duplicate log times in the spring and miss log times in the fall. To avoid confusion, many servers and data loggers are set to remain on GMT time and do not shift for daylight savings.

**Daylight Savings Start**

This is the date that daylight savings will start. Note that on this date, between the hours of 12:00 AM – 5:00 PM, the current time will be shifted forward by one hour (i.e. The time will jump from 12:02 AM to 1:02 AM). By default this is set to the 2nd Sunday in March which is the date used in the United States.

**Daylight Savings End**

This is the date that daylight savings will end. Note that on this date, between the hours of 12:00 AM – 5:00 PM, the current time will be shifted backward by one hour (i.e. The time will jump from 12:02 AM to 11:02 PM the day before). By default this is set to the 1st Sunday in November which is the date used in the United States.

## 2.4.6 Logging Tab

The WebRelay-Dual™ can be configured to record data such as changes in relay and input state. The logged data is stored in internal non-volatile memory and can be retrieved by entering the command `http://ipaddress/log.txt`. The WebRelay-Dual™ can be configured to log on a periodic basis and on event triggers. For more information on logging, see **Appendix D: Log Files**.

*Note that items are logged as result of an event only, and not periodically. Also, changing the log settings will erase the current log file.*

WebRelay-Dual™ Setup

Navigation: Main | Network | Advanced Network | Password | Date/Time | **Logging** | Inputs | Relays | Events | Script | Control Page Setup | Control Page

\*Items logged as result of an event only. Not periodically.

Logging Enabled: Yes  No

Start Time: 01 : 00

Logging Rate: 60 Mins  Hours  Days  Event Logging Only

	Log	Event Trigger
Relay 1	<input checked="" type="checkbox"/>	<input type="checkbox"/>
Relay 2	<input checked="" type="checkbox"/>	<input type="checkbox"/>
Input 1	<input checked="" type="checkbox"/>	<input type="checkbox"/>
Input 2	<input checked="" type="checkbox"/>	<input type="checkbox"/>
Vin	<input type="checkbox"/>	<input type="checkbox"/> 0.5
Events	<input type="checkbox"/>	*
XML Requests	<input type="checkbox"/>	*
MODBUS Requests	<input type="checkbox"/>	*
SNMP Requests	<input type="checkbox"/>	*

Filter Logged Requests: None  Reads  Writes

Next Log Time: Disabled

Submit Reset

Figure 2.4g—Logging Tab

### Logging Enabled

When this option is set to **Yes**, the WebRelay-Dual™ will record data as configured on this page. Note that this option controls data logging but not system logging. System logging is always enabled. The default setting for this option is **No**.

### Start Time

If a logging interval is specified (periodic logging rather than event logging), logging will occur relative to this start time. For example, if the start time is 01:00 and the logging rate is 6 hours, logging will occur at 01:00, 07:00, 13:00, and 19:00. Start time is specified in 24 hour time format. The default setting for this field is 01:00.

### Logging Rate

This field is used to specify the time period of logging. A numerical value is entered into the text field, and the unit of time is selected using the adjacent radio buttons. The range of values in this field is 1-20864. Time units are **Minutes**, **Hours**, and **Days**. Periodic logging can be disabled by selecting the **Event Logging Only** radio button.

### Logging Configuration

This table is used to select which information gets logged and what triggers the log entries. The table contains a column with a list of the relays and inputs, events and requests available, a column to select what gets logged, and a column to select which relay/input changes will trigger a log entry. The options within the first five lines of the table (Relay 1, Relay 2, Input 1, Input 2, and Vin) are straightforward. The Relay(s), Input(s), and Vin that have the associated **Log** box checked will have their current state logged within each log file record entry. These will be logged regardless of what triggers the log entry. In addition, each of the relays/inputs will cause a log file entry each time they change state if the associated **Event Trigger** box is checked. When Vin is selected with a trigger delta entered, if the Vin changes by the specified value, the device will log.

The options in the last four lines of the table (Events, XML Requests, MODBUS Requests, and SNMP Requests) function a bit differently. These are only logged when the associated **Log** box is checked AND they are only logged at the time they occur. For example, if the **Log** box next to XML requests is checked, a log entry will be made each time an XML request comes in from the network. If a log entry is caused by something else (for example a relay state changes), that entry will not contain any information about an XML request (or Events, or MODBUS Requests, or SNMP Requests).

The following Log/Event trigger options are available:

- Relay 1
- Relay 2
- Input 1
- Input 2
- Vin
- Events
- XML Requests
- Modbus Requests
- SNMP Requests

### Filter Logged Requests

When logging is enabled for XML Requests, MODBUS Requests, or SNMP Requests, the user can filter out **Reads** (such as reading the relay or input state via an XML request) or **Writes** (such as changing the relay state via an XML command). Filtering requests can be very useful to eliminate unwanted information. For example, on the **Control Page Setup** tab, the user can specify the refresh rate of the **Control Page**. Each time the page is refreshed, an XML request is sent, and logged as a Read. Since the default refresh rate is 3 seconds, the log file can get cluttered by many XML request logs. By selecting **Reads**, those XML requests will not be shown in the log. Likewise, by selecting **Writes**, any log created by changing the state of the relay will not be shown in the log file. Default selection is **None**.

### Next Log Time

This field displays the next periodic log time. If logging is disabled, the next log time will indicate "Disabled." If logging is enabled, but periodic logging is disabled (by selecting **Event Logging Only**) the next log time will indicate "Event Logging Only."

*Note that this information is updated only when the page is refreshed.*

## 2.4.7 Inputs Tab

This page provides configuration options for the two control inputs built into the WebRelay-Dual™. Note that in this manual the input is considered to be *on* when a voltage is applied to the input. The LEDs on the front panel of the WebRelay-Dual™ will illuminate whenever the inputs are in the *on* state.

The following screen appears when one of the control inputs is selected (Figure 2.4h):

Figure 2.4h—Inputs Tab

### Input

This drop down menu is used to select the control input to which the options below will apply:

- **Input 1 or Input 2:** Selects the control inputs.

### Description

This text field is used to describe the function of the selected input. The text also appears to the left of the corresponding input status on the Control Page, as well as in email messages when email alerts are enabled. This field may be up to 24 characters long. The default text is `Input #`.

### On Status Text

The text in this field specifies the text that will be displayed when the input is *on* (voltage applied to input). Up to 15 characters may be entered in this field. The default text is `ON`.

### Off Status Text

The text in this field specifies the text that will be displayed when the input is *off* (voltage not applied to input). Up to 15 characters may be entered in this field. The default text is `OFF`.

### **Counter Options**

The inputs of the WebRelay-Dual™ can be configured to count the times their states change. This can be used in production to count the number of items being made, or can be used as a door counter to track the number of customers entering a store. The following options are available:

- **Counter off:** No counts of the inputs will be tracked.
- **Increment when input on:** The counter will increment each time the input turns on.
- **Increment when input off:** The counter will increment each time the input turns off.
- **Increment when input changes:** The counter will increment each time the input changes on and off.

*Note the default setting for this field is **Counter off**.*

### **Reset Count**

Text entered here specifies when the counter will be reset. Values range from 0 to 4000000000. The default text is 4000000000.

### **Email Option**

Simple email messages can be sent in response to alarm conditions. This parameter is used to specify what alarm conditions, if any, will cause email messages to be sent. Note that email notification will work only if the email settings are correctly set up in the Network setup page. The following options are available:

- **No Email Messages:** No email notifications will be sent due to alarm conditions.
- **Send Email when input on:** Email notifications will be sent when input state changes to *on*.
- **Send Email when input off:** Email notifications will be sent when input state changes to *off*.
- **Send Email when input changes state:** Email notifications will be sent when input changes state to *on* or *off*.

*Note the default setting for this field is **No Email Messages**.*

### **Use Email Address**

If email messages are to be sent out based on alarm conditions, these check boxes specify to which email addresses the message will be sent. Email addresses specified on the **Network** setup tab will be displayed next to each check box. By default, no boxes are checked.

### **Remote Service/SNMP**

When this box (Send State Msg/Trap on Input Change) is checked, SNMP traps and/or State messages will be sent whenever the relay state changes.

## 2.4.8 Relays Tab

This page provides configuration options for the two internal relays built into the WebRelay-Dual™, and up to two remote relays across the network. The remote relays can be any ControlByWeb™ product that has relays.

### Relay

This drop down menu is used to select the relay for which the options below will apply:

- **Relay 1 or Relay 2:** Selects the built in relays.
- **Remote Relay 1 or Remote Relay 2:** Selects remote relays.

The following screen appears when one of the internal relays is selected (Figure 2.4i):

The screenshot shows a web browser window titled "WebRelay-Dual" with the URL "http://192.168.1.2/setup.html". The page features the "WEBRelay™ Dual-III" logo and a "Setup" title. A navigation bar includes tabs for Main, Network, Advanced Network, Password, Date/Time, Logging, Inputs, Relays (selected), Events, Script, Control Page Setup, and Control Page. The "Relays" tab is active, displaying configuration options for "Relay 1".

Configuration options for Relay 1:

- Relay:** Relay 1 (dropdown menu)
- Relay Description:** Relay 1 (text field)
- On Button Label:** ON (text field)
- Off Button Label:** OFF (text field)
- Pulse Button Label:** PULSE (text field)
- On Status Text:** ON (text field)
- Off Status Text:** OFF (text field)
- Pulse Duration:** 1.5 Seconds (text field)
- Relay State At Powerup:** off (unless overridden by event) (dropdown menu)
- Relay Option:** no local relay control (dropdown menu)
- Email Option:** No Email Messages (dropdown menu)
- Use Email Address:** (checkboxes)
- Remote Service/SNMP:** Send State Msg/Trap on Relay Change (checkbox)

Buttons for "Submit" and "Reset" are located at the bottom of the configuration area.

Figure 2.4i—Relays Tab—Local Relay Configuration

### Relay Description

This text field is used to describe the function of the selected relay. The text appears to the left of the corresponding relay status on the **Control Page**, as well as in email messages when email alerts are enabled. Up to 24 characters may be entered in this field. The default text is `Relay #`.

### On Button Label

The text entered in this field appears in the 'On' button for the corresponding relay on the **Control Page**. Up to 15 characters may be entered in this field. The default text is `ON`.

### Off Button Label

The text entered in this field appears in the 'Off' button for the corresponding relay on the **Control Page**. Up to 15 characters may be entered in this field. The default text is `OFF`.

**Pulse Button Label**

The text entered in this field appears in the 'Pulse' button for the corresponding relay on the Control Page. Up to 15 characters may be entered in this field. The default text is `PULSE`.

**On Status Text**

The text in this field specifies the text that will be displayed in the status field when the corresponding relay on the Control Page when the relay coil is energized. Up to 15 characters may be entered in this field. The default text is `ON`.

**Off Status Text**

The text in this field specifies the text that will be displayed in the status field when the corresponding relay on the Control Page when the relay coil is not energized. Up to 15 characters may be entered in this field. The default text is `OFF`.

**Pulse Duration**

When the WebRelay-Dual™ receives a pulse command for the relay (through the web page or the command interface), the relay will turn on for the time specified in this field and then turn off. Note that when a pulse command is sent through the command interface, the command can include a pulse time which will over-ride this value (for that pulse only). The time is specified in seconds and can range from 0.1 seconds to 86400 seconds in 0.1 second increments. Default time is 1.5 seconds.

**Relay State at Powerup**

This drop down menu lets the user specify the state of each of the internal relays when the WebRelay-Dual™ is powered up. The following options can be selected:

- **off (unless overridden by event):** the relay coil will not be energized upon power up. This is the default setting.
- **on (unless overridden by event):** the relay coil will be energized when power is applied to the WebRelay-Dual™.
- **last state (unless overridden by event):** upon power up, the relay coil will assume its last state when the WebRelay-Dual™ was powered off.
- **input state (unless overridden by event):** upon power up, if a voltage is applied to the input, the relay coil will be energized.
- **opposite of input state (unless overridden by event):** upon power up, the relay coil will assume the opposite state of the input.

*Note that each setting will be overridden by an active event.*

**Relay Option**

The optically-isolated input can be configured to control the relay. The options in this drop down menu are used to specify if and how the input affects the local relay, and are described below. Note that in all cases, input changes will only affect the relay at the time the input is changed. Once the change has taken place the state of the input has no effect on the state of the relay. In other words, if the input causes the relay to go on, a user may turn the relay off from the web browser, even if the input is still on. Note that in all cases below, Input 1 will affect Relay 1 and Input 2 will affect Relay 2.

- **no local relay control:** the input has no effect on the local relay.
- **set relay equal input:** when a voltage is applied to the input, the relay turns *on*. When a voltage is removed from the input, the relay turns *off*.

- **set relay opposite of input:** when a voltage is applied to the input, the relay turns *off*. When a voltage is removed from the input, the relay turns *on*.
- **latch relay when input on (reset via web):** when a voltage is applied to the input, the relay turns *on*. Once the relay is *on* it will stay *on* (unaffected by input change) until it is turned *off* manually via the web (or command) by a user or the WebRelay-Dual™ is powered off. This option is useful for alarming functions.
- **latch relay when input off (reset via web):** when a voltage is removed from the input, the relay turns *on*. Once the relay is *on* it will stay *on* (unaffected by input change) until it is turned off via the web (or command) by a user or the WebRelay-Dual™ is powered off. This option is useful for alarming functions.
- **latch relay when input changes (reset via web):** when a voltage is applied to or removed from the input, the relay turns *on*. Once the relay is *on* it will stay *on* (unaffected by input changes) until it is turned off via the web (or command) by a user or the WebRelay-Dual™ is powered off. This option is useful for alarming functions.
- **toggle relay when input on:** when a voltage is applied to the input, the relay will change states. When a voltage is removed from the input, the relay will remain in its current state.
- **toggle relay when input off:** when a voltage is removed from the input, the relay will change states. When a voltage is applied to the input, the relay will remain in its current state.
- **toggle relay when input changes:** when a voltage is applied to or removed from the input, the relay will change states.
- **pulse relay when input on:** when a voltage is applied to the input, the relay will pulse for the Pulse Duration specified. The voltage may remain on or be removed and the pulse time will not be affected. If the voltage is applied, removed, and then re-applied before the end of the pulse time, the Pulse Duration timer will be restarted (it will re-start each time a voltage is applied) and the relay will continue to remain *on* until the timer expires.
- **pulse relay when input off:** when a voltage is removed from the input, the relay will pulse for the Pulse Duration specified. The voltage may remain off or be re-applied and the pulse time will not be affected. If the voltage is removed, re-applied, and again removed before the end of the pulse time, the Pulse Duration timer will be re-started (it will re-start each time a voltage is removed) and the relay will continue to remain *on* until the timer expires.
- **pulse relay when input changes:** when a voltage is applied to or removed from the input, the relay will pulse for the Pulse Duration specified. If the state of the voltage changes before the end of the pulse, the timer will be re-started (it will re-start each time the voltage changes) and the relay will continue to remain *on* until the timer expires.

### **Email Option**

Simple email messages can be sent in response to alarm conditions. This parameter is used to specify what alarm conditions, if any, will cause email messages to be sent. Note that email notification will work only if the email settings are correctly set up in the Network setup page. The following options are available:

- **No Email Messages:** No email notifications will be sent due to alarm conditions.
- **Send Email when relay on:** Email notifications will be sent when relay state changes to *on*.
- **Send Email when relay off:** Email notifications will be sent when relay state changes to *off*.
- **Send Email when relay changes state:** Email notifications will be sent when relay changes state to *on* or *off*.

*Note the default setting for this field is **No Email Messages**.*



**Use Email Address**

If email messages are to be sent out based on alarm conditions, these check boxes specify to which email addresses the message will be sent. Email addresses specified on the **Network** setup tab will be displayed next to each check box. By default, no boxes are checked.

**Remote Service/SNMP**

When this box (Send State Msg/Trap on Input Change) is checked, SNMP traps and/or State messages will be sent whenever the relay state changes.

The following screen is displayed when one of the Remote Relays is selected (Figure 2.4j)

This page is used to configure network settings and access to remote relays.

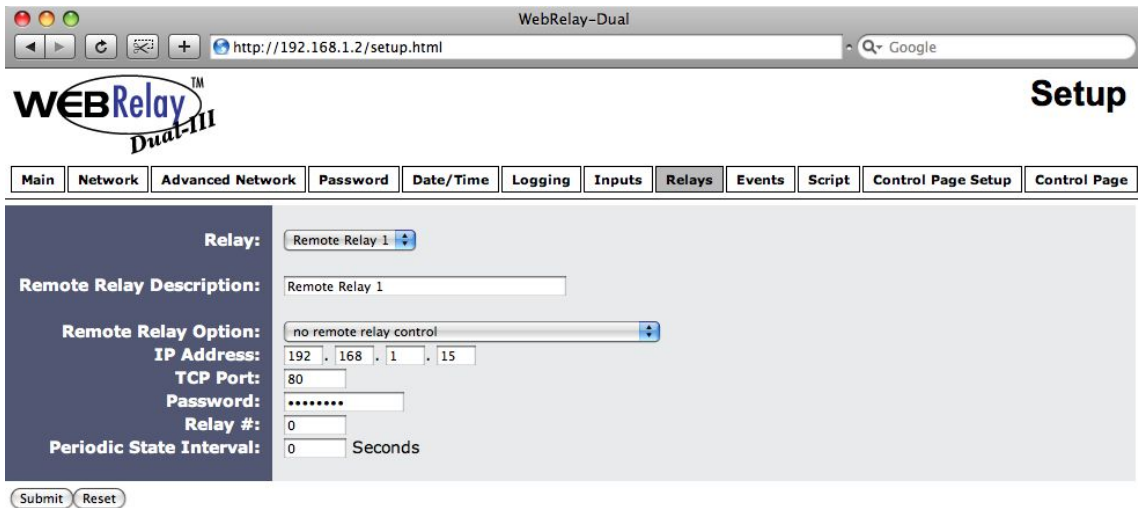

Figure 2.4j—Relays Tab—Remote Relay Configuration

**Remote Relay Description**

Text entered in this field describes the function of the selected remote relay. This text is used for reference purposes only and may be up to 24 characters long. Default text is Remote Relay #.

**Remote Relay Option**

The optically-isolated inputs can be configured to control the WebRelay-Dual™ device (as well as other ControlByWeb™ products) at a remote location. The 'Remote Relay Options' setting is used to specify if and how the input affects the remote relay. The options in the drop down list are described below. Note that in all cases, input changes will only affect the remote relay at the time the input is changed. Once the change has taken place the state of the input has no effect on the state of the remote relay. In other words, if an input causes the remote relay to go on, a user may turn the remote relay off from the web browser, even if the local input is still on. Note that in all cases below, Input 1 will affect Remote Relay 1 and Input 2 will affect Remote Relay 2.

- **no remote relay control:** the input has no effect on the remote relay.
- **remote command equals input:** when a voltage is applied to the input, a command is sent to the remote WebRelay-Dual™ to set the relay state to on. When a voltage is removed from the input, a command is sent to the remote WebRelay-Dual™ to set the relay state to off.
- **remote command opposite of input:** when a voltage is applied to the input, a command is sent to the remote WebRelay-Dual™ to set the relay state to off. When a voltage is removed

- from the input, a command is sent to the remote WebRelay-Dual™ to set the relay state to on.
- **send on command when input on (no off command)**: when a voltage is applied to the input, a command is sent to the remote WebRelay-Dual™ to set the relay state to on. When a voltage is removed from the input, no commands are sent to the remote WebRelay-Dual™.
  - **send on command when input off (no off command)**: when a voltage is removed from the input, a command is sent to the remote WebRelay-Dual™ to set the relay state to on. When a voltage is applied to the input, no commands are sent to the remote WebRelay-Dual™.
  - **send off command when input off (no on command)**: when a voltage is removed from the input, a command is sent to the remote WebRelay-Dual™ to set the relay state to off. When a voltage is applied to the input, no commands are sent to the remote WebRelay-Dual™.
  - **send off command when input on (no on command)**: when a voltage is applied to the input, a command is sent to the remote WebRelay-Dual™ to set the relay state to off. When a voltage is removed from the input, no commands are sent to the remote WebRelay-Dual™.
  - **send pulse command when input on**: when a voltage is applied to the input, a command is sent to the remote WebRelay-Dual™ to pulse the relay. When a voltage is removed from the input, no commands are sent.
  - **send pulse command when input off**: when a voltage is removed from the input, a command is sent to the remote WebRelay-Dual™ to pulse the relay. When a voltage is applied to the input, no commands are sent.
  - **send pulse command when input changes**: when a voltage is applied to the input or removed from the input, a command is sent to the remote WebRelay-Dual™ to pulse the relay.
  - **send toggle command when input on**: when a voltage is applied to the input, a command is sent to the remote WebRelay-Dual™ to toggle the relay (change the remote relay to the state opposite of its current state). When a voltage is removed from the input, no commands are sent.
  - **send toggle command when input off**: when a voltage is removed from the input, a command is sent to the remote WebRelay-Dual™ to toggle the relay (change the remote relay to the state opposite of its current state). When a voltage is applied to the input, no commands are sent.
  - **send toggle command when input changes**: when a voltage is applied to the input or removed from the input, a command is sent to the remote WebRelay-Dual™ to toggle the relay (change the remote relay to the state opposite of its current state).
  - **remote relay equals local relay**: this option is used to “daisy-chain” ControlByWeb™ units. In this mode, commands are sent to the remote WebRelay™ based upon the state of the local relay and not the local input. When the local relay changes state to on, a command is sent to the remote WebRelay™ to set the relay state to on. When the local relay changes state to off, a command is sent to the remote WebRelay™ to set the relay state to off.
  - **remote relay equals input (heartbeat mode)**: This is used for a "fail-safe" alarm configuration. This configuration is described as "fail-safe", because an alarm event will sound the alarm, or a network or equipment failure will also sound the alarm. This configuration is used with a remote WebRelay™ that controls the alarm. The alarm would be wired to the WebRelay™ using the normally-closed contacts, so as long as the relay is "on", the alarm will remain off. Under normal conditions, the relay stays on because the WebRelay-Dual™ sends periodic pulse messages that keep the relay turned on. If an alarm condition occurs, the WebRelay-Dual™ will send a message to the WebRelay™ unit to turn

off the relay and sound the alarm. If there is an equipment failure (for example, the network switch failed), the WebRelay™ will stop receiving the pulse messages. As soon as the pulse timer in the WebRelay™ expires, the WebRelay™ will turn off its relay and the alarm will sound. Note that this can also be used with normally open contacts to ensure that a remote device doesn't remain on in case of a network failure.

When the option **remote command equals input (heartbeat mode)** is selected, *Periodic State Interval* must be set (50000ms or less is recommended). Set the *Periodic State Interval* to just under half the pulse time specified in the remote WebRelay™. This configuration will cause the WebRelay-Dual™ to send a message to the remote WebRelay™ at the interval rate specified by the *Periodic State Interval*. When the input is high, it will send pulse commands. When the input is low, it will send off commands. In addition to sending commands at the specified interval, commands will be sent each time the input changes state.

### **IP Address**

The IP Address of the remote WebRelay-Dual™ is entered here. Commands are sent over the IP network to this address as the control voltage input changes. Default IP Address is 192.168.1.15.

### **TCP Port**

The TCP Port of the remote WebRelay-Dual™ is entered here. Commands are sent of the IP network to this TCP Port on the remote WebRelay-Dual™ as the control voltage input changes. The valid range is 0 to 65530. Default TCP Port entered here is 80.

### **Password**

If the remote WebRelay-Dual™ has a control password option enabled, the password for that unit must be entered here for the remote commands to have any effect.

### **Relay #**

This option is used to identify the specific relay within the remote device that will be controlled. If the remote device is a single WebRelay™, this option should be set to 0. If the remote device has multiple relays (such as another WebRelay-Dual™, or WebRelayQuad™) this option should be set to the relay number that will be controlled (1 or 2 for WebRelay-Dual™ and 1, 2, 3 or 4 for WebRelayQuad™). Default text here is 0.

### **Periodic State Interval**

When the WebRelay-Dual™ is configured to control a remote device, a connection is established. If the device does not receive a message for 50 seconds the connection is terminated. In order for the connection to be maintained, a message containing the state of the relay can be sent at a periodic interval. This field sets the time interval at which the message is sent. This field may be set to 0 or 10 to 50 seconds. The default setting is 0 seconds.

### 2.4.9 Events Tab

In addition to controlling the relays remotely over the network or by using a control voltage, events can be programmed to turn the relays on and off at specific times. Up to 100 events can be created. Each event can occur one time or multiple times.

The following screen appears when the Events Tab is selected (Figure 2.4k):

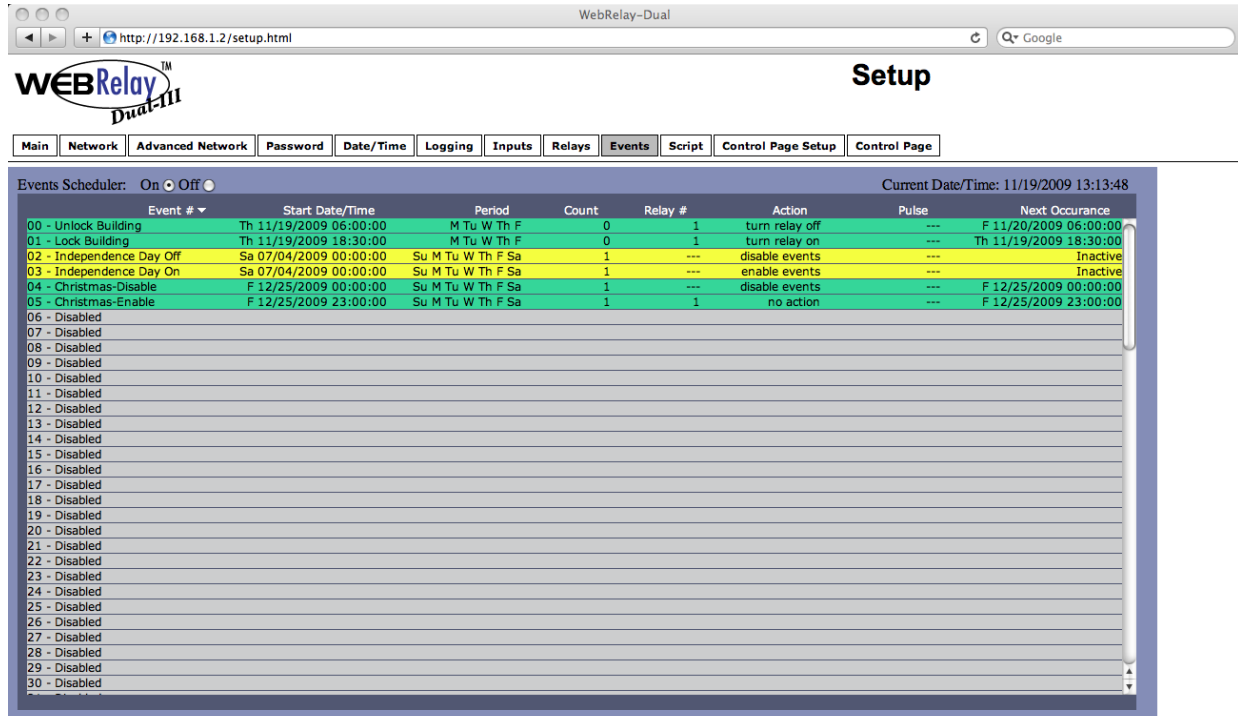

Figure 2.4k—Events Tab—Events Schedule

A list of all scheduled events and information about each event is displayed in a table. The following is displayed (Events can be sorted according to each column, in ascending or descending order):

- **Events Scheduler: On/Off:** Turns scheduled events on or off. *On* is selected by default.
- **Current Date/Time:** Displays the current date and time as specified in the **Date/Time** setup tab.
- **Event #:** The number and name of events are listed.
- **Start Date/Time:** The start date and time (displayed in 24-hour time) of the event is listed here.
- **Period:** The duration of the event.
- **Count:** The number of times the event will occur.
- **Relay #:** Which of the two internal relays, if any, will be affected by the event.
- **Relay Action:** If either of the two internal relays have been programmed to take action, that action will be displayed here.
- **Pulse:** The relays can be programmed to pulse upon the trigger of the event, and the pulse duration will be displayed.
- **Next Occurrence:** The date and time of the event's next occurrence will be displayed. If the event has already occurred, the event will be listed as "Inactive" here.

The events are color coded to indicate their current state. Gray events have not been set up. Green events are active and will occur sometime in the future. Red events are disabled. Yellow events have already occurred and are not scheduled to happen in the future.

Configuration of events is accomplished by clicking on the appropriate event, which causes the following setup screen to be displayed:

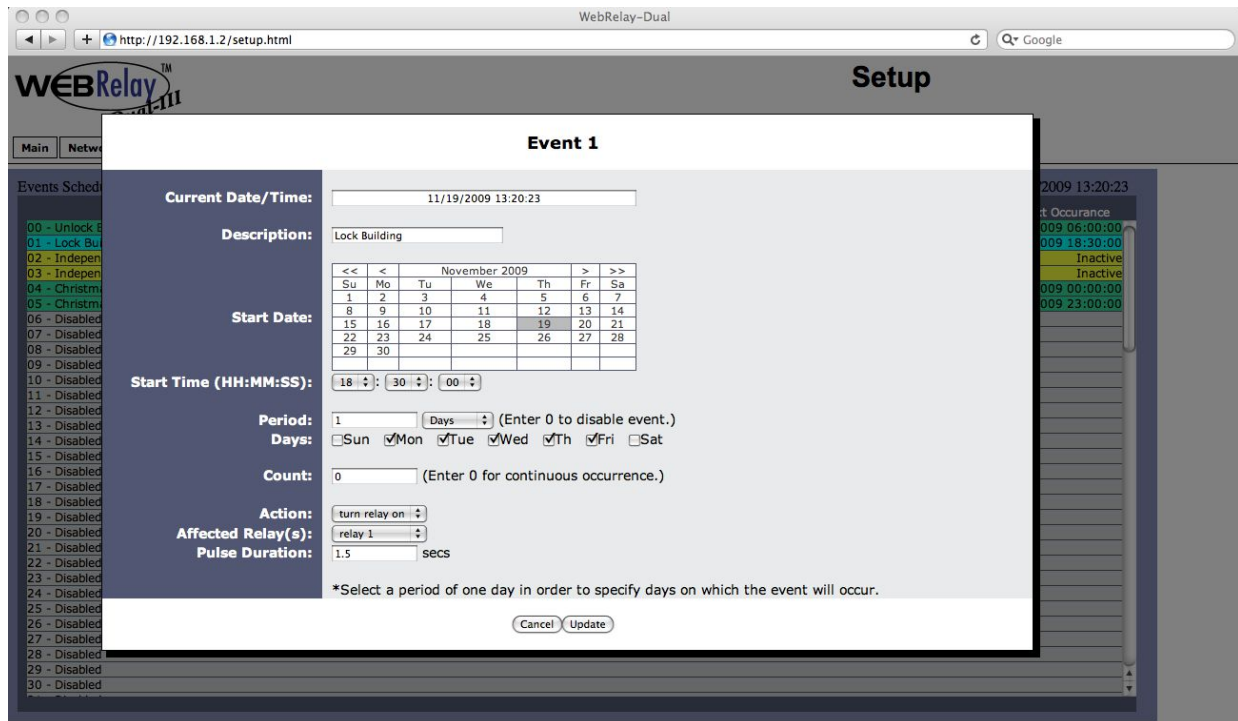

Figure 2.4I—Events Tab—Event Configuration

### **Current Date/Time**

This field displays the current date and time as specified in the **Date/Time** tab.

### **Description**

Text entered here is used to name and describe each event. Default text is `Event Description`.

### **Start Date**

This field is used to enter the start date of the event. The date is entered by first selecting the correct month and year by using the left and right arrows at the top of the calendar. The single arrows (< and >) change the month and the double arrows (<< and >>) change the year. Once the current month and year are displayed, the date should be entered by moving the mouse pointer over the correct day and clicking the (left) mouse button to highlight that date.

### **Start Time (HH:MM:SS)**

The start time of the event is entered in the drop down menus as HH:MM:SS (HH represents hours in 24-hour format (00-23), MM represents minutes (00-59), SS represents seconds (00-59)). Default setting is **00:00:00**.

**Period**

When events are configured to occur more than one time (any entry other than 1 in the Count below), the period field specifies the time between events. For long events (pulse relay), this is the time interval between the time the event begins and the next time the event begins. This time can be specified in *Seconds, Minutes, Hours, Days* or *Weeks* by selecting the appropriate option in the drop down menu. Default settings are 0 Days. Note that selecting 0 will disable the event.

**Days**

When a *Period* of one day is selected, the day (or days) in which that event will occur can be specified by marking the appropriate check boxes.

**Count**

The number of times the event will occur is specified. Default text is 0.

*Note: Entering 0 in this field will cause the event to occur continuously.*

**Action**

This drop down menu specifies which action will take place when the event occurs. The following options may be selected:

- **no action:** When this option is selected, nothing will happen when event occurs.
- **turn relay on:** This option causes relays specified in the 'Affected Relay(s)' field to turn on (coil energized) when event occurs.
- **turn relay off:** This option causes relay(s) specified in the 'Affected Relay(s)' field to turn off (coil de-energized) when event occurs.
- **pulse relay:** This option causes relay(s) specified in the 'Affected Relay(s)' field to turn on (coil energized) when event occurs, and then turn off (coil de-energized) after the pulse duration time (specified below) expires.
- **toggle relay:** This option causes the relay(s) specified in the 'Affected Relay(s)' field to change states.
- **disable events:** This option causes all events to be disabled at the specified time. When this event occurs, no events will be executed until another event with the **enable events** option occurs. This option is useful, for example, to prevent prescheduled daily events from happening on holidays.

*Note: events that would have occurred while the events were disabled will not be executed once events are enabled. For example, if an event were scheduled to turn Relay 1 on at 3:00 each day, but one day events were disabled until 3:10, the relay will not automatically turn on at 3:10 when the events are enabled. It will, however, turn on the next day at 3:00 (assuming events are still enabled).*

- **enable events:** This option is used after an event with the **disable events** option occurs to allow events to resume.
- **set extvar0:** External variables provide a way for scripts written in BASIC to interact with users, and for scripts to execute as a result of event occurrences. This option sets the variable extvar0 to 1 when the event occurs. If a running script uses this variable, it will function as defined in the script when the variable is set to 1.
- **clear extvar0:** This option clears extvar0 (sets it to 0) when the event occurs. See *description of set extvar0 for more information.*

**Affected Relay(s)**

This drop down menu is used to specify which of the relays turn on upon occurrence of the event. One of the following options may be selected:

- **relay 1**
- **relay 2**
- **both relays**

**Pulse Duration**

If the *Relay Action* has been set to **pulse relay**, the Pulse Duration is set in this field. The time is specified in seconds and can range from 0.1 seconds to 86400 seconds in 0.1 second increments. Default time is 1.5 seconds.

## 2.4.10 Script Tab

The WebRelay-Dual™ can be used to run simple custom programs written in a language similar to BASIC. This page is used to load and execute these programs. Before loading a script to the WebRelay-Dual™, it must first be written as a .txt file. The file must then be uploaded to the WebRelay-Dual™. The maximum size of script that can be uploaded to the device is 2K bytes. Notes on writing a basic program for the WebRelay-Dual™ can be found in **Appendix G: Basic Scripts**.

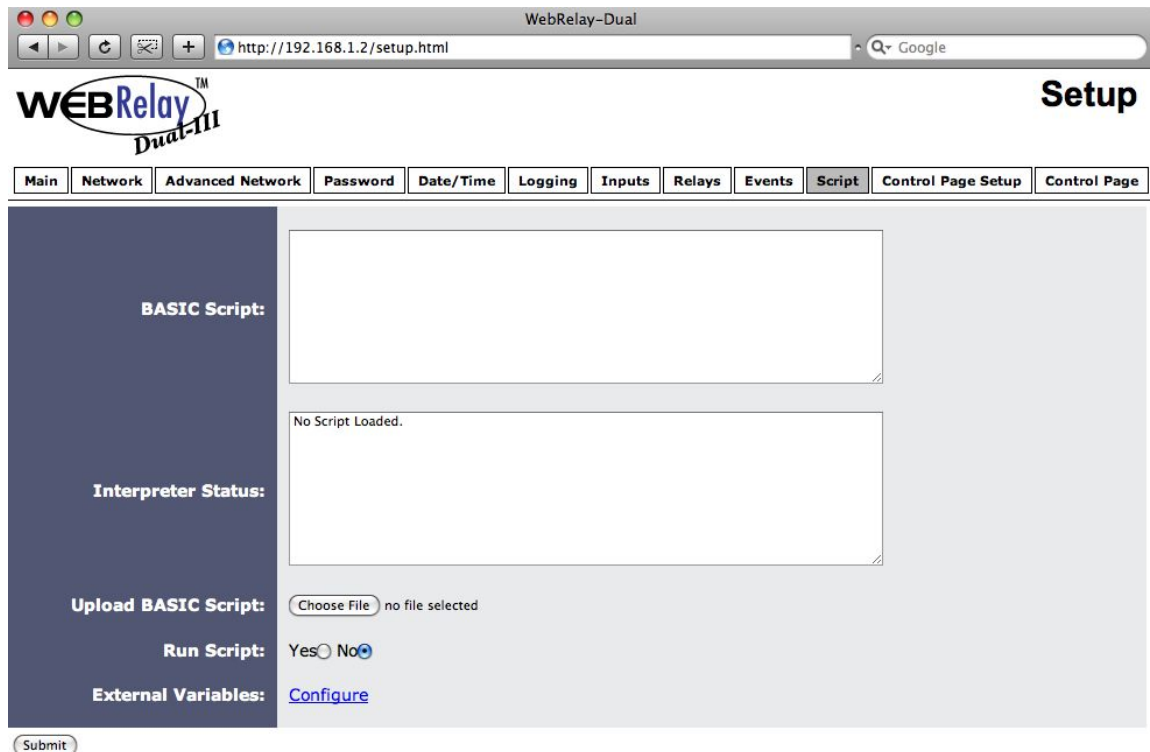

Figure 2.4m—Script Tab

### **BASIC Script**

This field displays the .txt file that is uploaded to the WebRelay-Dual™. Text displayed in this screen cannot be edited. In order to edit any script, it must be rewritten in the .txt file and uploaded again to the unit.

### **Interpreter Status**

This field displays whether the program is continuing to run, it has stopped or finished, or if there are errors contained in the script. If there are errors in the script, the line on which the error occurred is displayed.

### **Upload BASIC Script**

This field displays the script selected to be uploaded to the device. To upload a script to the WebRelay-Dual™ click the 'Choose File' button, find the .txt file previously written, and select 'Open.' the location of the file should appear in the neighboring field. To upload the script to the unit select 'Submit.'



**Run Script**

This option selects whether or not the selected script will be run after it has been uploaded. The Submit button must be clicked to run the script.

**External Variables**

External Variables are variables that can be used in basic scripts. They are called External Variables because their values can be changed externally to the basic script using xml requests, or through the control page. This allows basic scripts to react to user input. These variables are considered to be floating point numbers just like the other variables in the basic script.

The following page is displayed when configuring External Variables:

The screenshot shows a web browser window with the URL `http://192.168.1.2/extVarSetup.html`. The page content is a configuration form for external variables. On the left, there is a dark blue sidebar with labels for various fields. On the right, the corresponding input fields are visible. The 'External Variable' field is a dropdown menu currently showing 'extVar 0'. Below it are three checkboxes for 'Display State', 'Display Button 1', and 'Display Button 2', all of which are unchecked. The 'Description' field is a text input containing 'extVar0'. Below that are four text input fields for labels and status text: 'Button 1 Label' (ON), 'Button 2 Label' (OFF), 'Status 1 Text' (ON), and 'Status 2 Text' (OFF). At the bottom of the form are two buttons: 'Submit' and 'Reset'.

Figure 2.4n—External Variables Configuration

**External Variable**

This drop down menu offers the option to configure each of the five External Variables.

**Display State**

Checking this box will display the state of the selected External Variable on the control page.

**Display Button 1**

Checking this box will display a button on the control page. Clicking this button will set the extVar to value 1.

**Display Button 2**

Checking this box will display a button on the control page. Clicking this button will set the extVar to value 2.

**Description**

Text entered here will be displayed in the left column of the control page. Up to 24 characters may be entered here. The default text is extVar#.

**Button 1 Label**

This text field is used to describe the function button 1 of the selected extVar. The text also appears to the right of the corresponding extVar status. Up to 15 characters may be entered here. By default, this text is ON for a value of 1.

**Button 2 Label**

This text field is used to describe the function button 2 of the selected extVar. The text also appears to the right of the corresponding extVar status. Up to 15 characters may be entered here. By default, this text is OFF with a value of 0.

**Status 1 Text**

The text in this field specifies the text that will be displayed when the extVar is value 1, with a yellow background. The text also appears in the status column on the Control Page. Up to 15 characters may be entered here. By default the text is ON.

**Status 2 Text**

The text in this field specifies the text that will be displayed when the extVar is value 0, with a grey background. The text also appears in the status column on the Control Page. Note that if the extVar is any other value than 1 or 0, the value will be displayed in the same column, with a grey background. Up to 15 characters may be entered here. By default the text is OFF.

## 2.4.11 Control Page Setup Tab

The **Control Page Setup** page is used mainly to set parameters that affect the view of the **Control Page**, how often it will refresh, etc.

	Display State	Display Counter	Display Counter Reset Button	Display On/Off Buttons	Display Pulse Button
Input 1	<input checked="" type="checkbox"/>	<input checked="" type="checkbox"/>	<input checked="" type="checkbox"/>		
Input 2	<input checked="" type="checkbox"/>	<input checked="" type="checkbox"/>	<input checked="" type="checkbox"/>		
Relay 1	<input checked="" type="checkbox"/>			<input checked="" type="checkbox"/>	<input checked="" type="checkbox"/>
Relay 2	<input checked="" type="checkbox"/>			<input checked="" type="checkbox"/>	<input checked="" type="checkbox"/>

Figure 2.40—Control Page Setup Tab

### Main Header Text

The text entered here appears at the top of the **Control Page**. It also appears in the header of the email text when the email notification is used. This field can be up to 40 characters in length.

### Auto Refresh

Web pages traditionally display static information. The WebRelay-Dual™ **Control Page**, however, displays information that is dynamic. Each time the **Control Page** is loaded to a browser, it displays a snapshot of the current status of the unit. Whenever the state of a relay changes, the **Control Page** will be obsolete until the page is refreshed. The WebRelay-Dual™ cannot force the web page to be updated when the relay state changes. The Auto Refresh Page option will cause the **Control Page** to continually update its contents by setting a timer in the web page that causes it to be reloaded at a specified time interval.

### Refresh Rate

When the *Auto Refresh Page* option is set to **Yes**, this field specifies the time interval in seconds that the page will be refreshed. It can be set from 1 to 32 seconds.

### Display Configuration:

This field sets the options that are displayed on the **Control Page**.

- **Display State:** For Inputs 1 and 2, and Relays 1 and 2, this controls whether the current state of the Input or Relay is displayed.
- **Display Counter:** When checked, the counter of input high status will be displayed.
- **Display On/Off Buttons:** When checked, an ON/OFF button is displayed on the **Control Page** for direct user control.
- **Display Pulse Button:** When checked, a button allowing a user to manually pulse a specified relay is displayed.

### Section 3: Operation

The WebRelay-Dual™ can be operated by applying a voltage to the optically-isolated input, using a web browser, by sending text commands to an XML status/control page, or by sending Modbus/TCP requests. Using a control voltage was described throughout previous sections of the manual, and will not be described here.

#### 3.1 Browser Operation

Once the WebRelay-Dual™ is set up, users can access the Control Page using a web browser, accessed by typing the IP address of the WebRelay-Dual™ into the web browser address bar. For example, using the default IP address, the user would enter `http://192.168.1.2`. If the IP address is changed from the default, the user must use the new IP address. Note that if any port is used other than the default port 80, the port must also be included in the request. For example, accessing the unit at port 8000 would be as follows: `http://192.168.1.2:8000`.

This following screen appears when the Control Page is selected:



Figure 3.1a—Control Page

#### Header

displays the text entered in the Main Header Text field on the **Control Page Setup** tab in the setup pages.

#### Input 1 and 2

These rows display the current state of the two optically-isolated inputs, and a Count of how many times either input has had voltage applied. Each of these rows can be displayed (as shown) or not displayed by checking or deselecting the appropriate boxes in the **Control Page Setup** tab in the setup pages. The text in the left column (by default reads Input 1 and Input 2) is specified in the Description field in the **Input** tab in the setup pages.

**Relay 1 and 2**

These rows display the current state of the two internal relays and allows the user to change relay state. Each of these rows can be displayed (as shown) or not displayed by checking or unchecking the appropriate boxes in the **Control Page Setup** tab in the setup pages. The text in the left column (by default reads Relay 1 and Relay 2) is specified in the Description field in the **Relays** tab in the setup pages. The state of the relays is shown to the right of the relay description text. By default, the status text will read ON or OFF; however, the status text can be changed in the **Relays** tab. To the right of the relay status, buttons are provided to control the relays. The buttons can be removed when needed (in the **Control Page Setup** tab) and the text within the buttons can be customized (in the **Relays** tab).

**Current Time**

Displays the current time that is set using the **Date/Time** tab in the setup pages.

## 3.2 XML Operation

Custom computer applications may be created to monitor and control the WebRelay-Dual™ without using a web browser. There are two xml pages that can be used to monitor and control the WebRelay-Dual™. The two xml pages are state.xml, and eventX.xml (where X is the event number).

### 3.2.1 Controlling the Unit Through state.xml

The state of the inputs and relays can be monitored by sending a request to port 80 (or port specified in setup) for the XML page state.xml. The relays can be controlled by sending GET requests to the same page on port 80 (or port specified in setup). This can be demonstrated by entering commands into the address bar of a web browser.

Request the current state: `http://192.168.1.2/state.xml`

This will return the following XML page:

```
<datavalues>
  <input1state>0</input1state>
  <input2state>0</input2state>
  <relay1state>0</relay1state>
  <relay2state>0</relay2state>
  <hightime1>0.00</hightime1>
  <hightime2>0.00</hightime2>
  <count1>0</count1>
  <count2>0</count2>
  <extvar0>0.00</extvar0>
  <extvar1>0.00</extvar1>
  <extvar2>0.00</extvar2>
  <extvar3>0.00</extvar3>
  <extvar4>0.00</extvar4>
  <serialNumber>00:0C:C8:00:00:01</serialNumber>
  <time>1253030401</time>
</datavalues>
```

The tags <input1state>, <input2state>, <relay1state>, <relay2state>, and <input1hightime> indicate the current state of the WebRelay-Dual™. Values for each tag are described below.

XML Tag*	Monitored Value
<inputXstate>	0=off (voltage not applied to input one) 1=on (voltage applied to input one)
<relayXstate>	0=off (coil one off) 1=on (coil one energized)
<hightimeX>	This field indicates the amount of time that has elapsed, in seconds, since a voltage has been applied to input one or two. When the voltage is removed, the counter stops. When a voltage is reapplied to input one or two, the counter resets and begins counting again. This counter is also cleared when WebRelay-Dual™ loses power.
<countX>	This field displays the count of the times voltage has been applied to each input.
<extvarX>	This displays the value of each External Variable.
<serialNumber>	The serial number of the WebRelay-Dual™.
<time>	1253030401 = time displayed in "epoch time" (number of seconds since January 1, 1970).

\* 'X' is replaced by the input, relay, etc. number

### XML Control

Commands can be sent to the WebRelay-Dual™ which control the relay and change its state. Commands are sent using a variable called relayXState (X is replaced by 1 for relay 1 or 2 for relay 2). All relayXState options are given here.

Command	Description
state.xml?relay1State=0	Turn Relay 1 OFF
state.xml?relay1State=1	Turn Relay 1 ON
state.xml?relay2State=0	Turn Relay 2 OFF
state.xml?relay2State=1	Turn Relay 2 ON
state.xml?relay1State=2	Pulse Relay 1
state.xml?relay2State=5	Toggle the state of Relay 2

When the pulse command is sent to the WebRelay-Dual™, the relay will pulse for the time specified in the setup page. It is possible, however, to specify a pulse time that is different than the pulse time configured in the setup page. This is done by sending an additional variable called pulseTime along with the desired pulse time.

The pulseTime variable does not change the pulse time specified in the setup page and it is not stored or recorded. The pulseTime variable only changes the pulse duration for the single pulse initiated by that command. In other words, you must issue the pulseTime for each pulse command that differs from the preset pulse time. For example, suppose the pulse time is set to 1.5 seconds in the configuration pages. To issue one 1.5 second pulse, three 5 second pulses, and a 1.5 second pulse once again to relay one, you would issue the following commands:

Command	Description
state.xml?relay1State=2	Pulse Relay 1 for the preset time (1.5 seconds).
state.xml?relay1State=2&pulseTime1=5	Pulse Relay 1 for 5 seconds.
state.xml?relay1State=2&pulseTime1=5	Pulse Relay 1 for 5 seconds.
state.xml?relay1State=2&pulseTime1=5	Pulse Relay 1 for 5 seconds.
state.xml?relay1State=2	Pulse Relay 1 for the preset time (1.5 seconds).

Note that `http://192.168.1.2/` would be included on all commands above.

### XML Set Counter

The counter value can be set using the `countx` command. Refer to **2.4.7 Inputs Tab** for information on maximum count values.

Command	Description
state.xml?count1=200	Set counter1 to 200.

### Message Acknowledgment

When commands are sent to the WebRelay-Dual™, its current state is returned in the form of an XML page. The commands can also be sent without having the WebRelay-Dual™ return the XML page. This is accomplished by adding the `noReply` field as follows:

Command	Description
state.xml?relay1State=1&noReply=1	Turn Relay 1 <i>ON</i> without returning state
state.xml?relay1State=0&noReply=1	Turn Relay 1 <i>OFF</i> without returning state



### 3.2.2 Monitoring Events Through eventX.xml

The relays can be configured to turn on, turn off, or pulse at specified times. Instructions to change the relay state at a given time (or periodically) are called events. The WebRelay-Dual™ supports 100 events and these events can be monitored through an XML page called eventX.xml (where X is the event number 0-99). This can be demonstrated by entering commands into the address bar of a web browser.

Request the current state of event one: <http://192.168.1.2/event0.xml>

This will return the following XML page:

```
<event0>
  <active>yes</active>
  <currentTime>09/14/2009 15:14:09</currentTime>
  <nextEvent>09/15/2009 15:15:00</nextEvent>
  <period>1 s</period>
  <count>10</count>
  <relay>1</relay>
  <action>pulse relay</action>
  <pulseDuration>0.5 s</pulseDuration>
</event0>
```

Each of the tags are described below.

Tags*	Description
<eventX>	Event tag where X represents the event number (0-99).
<active>	This field indicates whether or not the event is active. The text <i>yes</i> indicates that the event is active and the event will occur at the next event time. The text <i>no</i> indicates that the event is inactive and the event will no longer take place.
<currentTime>	This field indicates the current date and time as MM/DD/YYYY HH:MM:SS in 24-hour format.
<nextEvent>	The next time the event is scheduled to occur is given as MM/DD/YYYY HH:MM:SS. If an event is inactive, this field will display the date and time as xx/xx/xxxx xx:xx:xx.
<period>	For events that occur more than one time, this field indicates the period of the event (time between event occurrences). The unit of time is indicated after the value (seconds (s), minutes (m), hours (h), days (d), or weeks (w)). If this field is set to 0, then the event has been disabled. For example 1d would be a period of 3 days.
<count>	This field indicates the number of remaining times the event will occur. If this field is 0 and the event is active, then the event is always on.
<relay>	Event will apply to the relay specified (1 or 2)
<action>	One of the follow actions is applied to the event. turn relay(s) on turn relay(s) off pulse relay(s) toggle relay(s) disable events set extVar0 clear extVar0
<pulseDuration>	This field indicates the time (in seconds) that the relay will be turned on.

### 3.2.3 XML Diagnostics

There is a special xml page that can be requested for diagnostic purposes called diagnostics.xml. A request for this file (by typing `http://ipaddress/diagnostics.xml` in the browser address bar) returns the following:

```
<datavalues>
  <internalTemp>91.6</internalTemp>
  <vin>12.1</vin>
  <fiveVolt>5.0</fiveVolt>
  <memoryPowerUpFlag>1</memoryPowerUpFlag>
  <devicePowerUpFlag>1</devicePowerUpFlag>
  <powerLossCounter>7</powerLossCounter>
</datavalues>
```

Diagnostic tags are given in the table below.

Tag	Description
<internalTemp>	Indicates the internal temperature of the device.
<vin>	Indicates the DC voltage that is applied to the VIN+ and Vin- terminals.
<internal5Volt>	Indicates the DC voltage of the internal 5V power supply.
<memoryPowerUpFlag>	Indicates a loss of power to the capacitor-backed real-time clock. A value of 1 indicates that the real-time clock lost power. This should only happen if the device has lost power for several days. There is an internal capacitor that can power the real-time clock for an extended period of time, even if the main power is lost. If the real-time-clock loses power, the time will have to be reset. By default, this will read 1 until it is set to 0.
<devicePowerUpFlag>	Indicates a loss of power to the device. This field can also be set to 0. A value of 1 means the WebRelay-Dual™ has lost power at least one time since the flag was set to 0.
<powerLossCounter>	This field is a count of how many times the WebRelay-Dual™ has lost main power.

The <devicePowerUpFlag> and <memoryPowerUpFlag> can be cleared by requesting the file diagnostics.xml and passing parameters along with this request. For example, to clear both flags, the following request can be sent to the device:

```
http://192.168.1.2/diagnostics.xml?memoryPowerUpFlag=0&devicePowerUpFlag=0
```

The powerLossCounter can also be cleared by using the request:

```
http://192.168.1.2/diagnostics.xml?powerLossCounter=0
```

Requests for the diagnostics.xml file do not require a password.

## 3.3 GET Requests

### 3.3.1 Using GET for Control and Monitoring

#### No Password

GET requests to the device for XML files.

Example request about.html:

```
GET /about.html HTTP/1.1\r\n\r\n
```

Example turn Output 1 On:

```
GET /state.xml?relay1State=1\r\n\r\n
```

#### Password Enabled

If the Control Password is enabled on WebRelay-Dual™ and the state.xml page is requested through a browser, the user will be prompted for a password. If the XML request is sent from an XML application, the html request will need to contain the password, encoded as Base64.

The following is an html request header without the password:

```
GET /state.xml?relay1State=1&noReply=1 HTTP/1.1 (Terminated with two \r\n.)
```

The following example adds the password:

```
GET /state.xml?relay1State=1&noReply=1 HTTP/1.1 (Terminated with \r\n.)
Authorization: Basic bm9uZTp3ZWJyZWxheQ== (Terminated with two \r\n.)
```

bm9uZTp3ZWJyZWxheQ== is the Base64 encoded version of the user "name:password,"  
none:webrelay.

A utility is provided at <http://www.controlbyweb.com/encoder> to encode the password. Simply type the string username:password into the website and press 'Encode'.

### 3.3.2 http (GET) Event Configuration

Events can be configured using a get request. For example, to configure event 5 to start on March 8, 2009 at 02:30:10 and continue periodically every second 50 times, toggling the relay each time, send the following request (using the default IP address):

```
http://192.168.1.2/eventSetup.srv?
e5=12369410;1;0;50;0;4;1.50;0Event5Desc;127;
```

The basic format of the request is:

```
e(event#)=date/time;period;period units;count;relay number;relay action;pulse duration;0;description;
days;
```

Parameter	Description
e5=	<b>Parameter Name:</b> Each event has an identifier (0-99). In this case the parameter name is e5. Event 100 would be e99.
1290168000	<b>Epoch Time:</b> The number of seconds up to the desired start date since January 1, 1970.
1	<b>Period:</b> The period value.
3	<b>Period Units:</b> The units of the period, 0-Seconds, 1-Minutes, 2-Hours, 3-Days, 4-Weeks.
0	<b>Count:</b> Number of times the event will occur. (0 = continuous)
1	<b>Relay #:</b> This number represents which Relay will be affected by the event. This value is the base ten version of a binary number where each bit represents the ON/OFF state of one output. Bit 0 = Relay 1, Bit 1 = Relay 2, Bit 2 = Both Relays.
1	<b>Action:</b> 0-No Action, 1-Turn Relay On, 2-Turn Relay Off, 3-Pulse Relay, 4-Toggle Relay, 5- Disable Events, 6- Enable Events, 7-Set extVar0, 8-Clear extVar0.
4	<b>Pulse Duration:</b> Pulse duration when using the pulse output action.
0	<b>Next Occurrence:</b> This is a report value only, indicating the next time this event will occur in Epoch Time. When setting an event leave this at 0.
Event5Desc;	<b>Description:</b> Text description of the event, up to 20 characters can be entered.
127	<b>Days:</b> This number represents which days the event will occur. This value is the base ten version of a binary number where each bit represents one day of the week. Bit 0 is Saturday and Bit 6 is Sunday. See the table below for some common values.

### 3.3.3 Common Base Ten Values for Event Days

Sunday	Monday	Tuesday	Wednesday	Thursday	Friday	Saturday	Base 10 Value
Bit 6	Bit 5	Bit 4	Bit 3	Bit 2	Bit 1	Bit 0	--
1	1	1	1	1	1	1	127
0	1	1	1	1	1	0	62
0	1	0	1	0	1	0	42
0	0	1	0	1	0	0	20
0	0	0	0	0	0	1	1

### 3.4 Modbus Operation

WebRelay-Dual™ can be controlled (and read) using Modbus/TCP protocol. This provides a standard means of using WebRelay-Dual™ in conjunction with devices and software from other manufacturers. This section contains the information necessary to communicate with WebRelay-Dual™ using Modbus/TCP. This is not a tutorial on Modbus and it is assumed that the reader is already familiar with Modbus. Detailed Modbus information can be found at <http://www.modbus.org>.

WebRelay-Dual™ functions as a Modbus server (slave). Client (master) devices and software open a connection with the WebRelay-Dual™ on port 502 (unless another Modbus port is selected) and sends commands or requests to read the state of the relay, read the input, or change the relay state. When the WebRelay-Dual™ receives a command, it will perform the desired function and return a response. The underlying structure of these commands can be found in the next sections, although most software and Modbus devices can be configured by reading through the following section only.

There are generally two ways that Modbus software and PLCs use to communicate with a Modbus device. The first is by specifying the Modbus function code/memory type and an address. The second, sometimes called PLC addressing, requires the address only. Under PLC addressing, the function code/memory type is a given based on the PLC address. Once the address is known, the data size must be specified. The inputs and relays are discrete data types. The input high times are 32 bit floating point numbers. For these, a quantity of two registers must be read starting at the desired address. The following table gives commonly used function code/memory types, data sizes, and equivalent PLC addresses for accessing the device. The data size will be the same regardless of the addressing mode.

	Function Code and Address	Data Size	PLC Address Mode 485	PLC Address Mode 584/984
Read Relay 1 State	Function code 01 Address 0	Discrete	1	1
Read Relay 2 State	Function code 01 Address 1	Discrete	2	2
Write Relay 1	Function code 05 Address 0	Discrete	1	1
Write Relay 2	Function code 05 Address 1	Discrete	2	2
Read Input 1 State	Function code 02 Address 0	Discrete	1001	10001
Read Input 2 State	Function code 02 Address 1	Discrete	1002	10002
Read Input 1 High Time	Function code 03 Address 20	32 Bit Float (2 Registers)	4021	40021
Read Input 1 High Time	Function code 03 Address 22	32 Bit Float (2 Registers)	4023	40023

Regardless of the addressing scheme used, it is important to note that when the control password in the WebRelay-Dual™ is enabled, Modbus/TCP communications are disabled. This is because Modbus/TCP does not provide a mechanism for password protection. Make sure the control password is disabled (default) before using Modbus with the WebRelay-Dual™. Also, Modbus functionality must be enabled on the **Advanced Network** tab before the device will respond to modbus requests.

The WebRelay-Dual™ supports the following function codes/memory types:

- Read Coils (Modbus function 01): Read the status of the relays (and/or inputs).
- Read Discrete Inputs (Modbus function 02): Read the status of the inputs.
- Read Holding Registers (Modbus function 03): Read back how long input one remained high (voltage applied most recently).
- Write Single Coil (Modbus function 05): Change the relay state.
- Write Multiple Coils (Modbus function 15): Change one or more relay states.
- Write Multiple Registers (Modbus function 16): Pulse one or more relays.

These function codes/memory types and addresses can be converted to the PLC addressing equivalent using the table below. To use the table look-up the row corresponding to the Modbus function code. Then take the desired Modbus address and add to it the address offset found in the column for the PLC addressing mode desired.

	PLC Addressing 485 Mode	PLC Addressing 584/984 Mode
Read Coils (function 01)	Addr + 1	Addr + 1
Write Coil (function 05)	Addr + 1	Addr + 1
Read Discrete Inputs (function 02)	Addr + 1001	Addr + 10001
Read Holding Registers (function 03)	Addr + 4001	Addr + 40001
Write Holding Registers (function 16)	Addr + 4001	Addr + 40001

For example, to read the state of relay 1 (coil 1), the Modbus function code 01 is used. To convert this function code/address pair to a PLC address we look-up the read coils row of the table above and see that adding 1 to the address gives us a PLC address of 2. To read the input 1 high time (holding register 20), we use the function code/address pair 3/20. This function code/address pair can then be converted to a PLC 584 address by looking at the Holding Registers row. Adding 40001 to the original address gives us the PLC address 40021.

Multiple commands may be sent without closing and re-opening the connection but if no data is transferred for 50 seconds, the connection will time out and close. To keep the connection open, a read request can be sent periodically. The WebRelay-Dual™ has two TCP sockets available for Modbus/TCP which allows two connections to be open at one time. Requests for more than two open connections will be rejected.

When errors occur, an error code is sent. Most Modbus client software will interpret this code into a human readable form. This code is comprised of the function code sent plus 0x80. For example, an error during the read coils function 0x01 would return 0x81. Each error has a qualifying exception number. The following are the possible exception codes and their meanings:

- 0x01 - Function code not supported (also returned when Modbus is disabled in the setup pages).
- 0x02 - Incorrect starting address/quantity of outputs combination.

The remaining sections give a detailed, low level description of the Modbus functions supported.

### 3.4.1 Read Coils (Modbus Function Code 01 (0x01))

This function returns the state of the relay coils. 0 denotes that the coil is not energized, 1 denotes that the coil is energized. In addition, the optically-isolated inputs can be read using this function which allows the full state of the WebRelay-Dual™ to be read in a single transaction.

#### Valid Starting Address and Quantity of Coils combinations

Valid starting addresses can fall in the range of 0x0000 and 0x0004. Valid quantities can also fall in the range of 0x0000 and 0x0004. The only restriction is that the sum of the starting address and the quantity of coils must not be greater than 0x0004. For example, if you want to read 0x0004 bits, two coils and two inputs, then the starting address would be 0x0004. If you want to read the inputs only you may read 0x0002 bits and use the starting address of 0x0002. On the other hand, you may want to read the second relay state only. This can be achieved by starting at address 0x0001 and using a quantity of 0x0001.

#### Request

##### Modbus/TCP:

Transaction identifier (2 Bytes): 0x0001  
 Protocol identifier (2 Bytes): 0x0000  
 Length (2 Bytes): 0x0006  
 Unit Identifier (1 Byte): 0xff

##### Modbus:

Function Code (1 Byte): 0x01 (read coils)  
 Starting address (2 Bytes): 0x0000 (0x0000 to 0x0004)  
 Quantity of Coils (2 Bytes): 0x0004 (0x0001 to 0x0004)

#### Character String example:

```
char read_coils_mb_request[ ]={0x00, 0x01, 0x00, 0x00, 0x00, 0x06, 0xff,
0x01, 0x00, 0x00, 0x00, 0x04 };
```

#### Response

##### Modbus/TCP:

Transaction identifier (2 Bytes): 0x0001  
 Protocol identifier (2 Bytes): 0x0000  
 Length (2 Bytes): 0x0004  
 Unit identifier (1 Byte): 0xff

##### Modbus:

Function code (1 Byte): 0x01 (read coils)  
 Byte count (1 Byte): 0x01  
 Coil status (1 Byte): 0x00 to 0x0F (bit 0=relay state 1, bit 1=relay state 2, bit 3=input state 1, bit 4=input state 2)

Data Byte (hex)	LS Date Bits (binary)	Input 2 State	Input 1 State	Relay 2 State	Relay 1 State
0x00	0000	Low	Low	Off	Off
0x01	0001	Low	Low	Off	On
0x02	0010	Low	Low	On	Off
0x03	0011	Low	Low	On	On
0x04	0100	Low	High	Off	Off
0x05	0101	Low	High	Off	On
0x06	0110	Low	High	On	Off
0x07	0111	Low	High	On	On
0x08	1000	High	Low	Off	Off
0x09	1001	High	Low	Off	On
0x0A	1010	High	Low	On	Off
0x0B	1011	High	Low	On	On
0x0C	1100	High	High	Off	Off
0x0D	1101	High	High	Off	On
0x0E	1110	High	High	On	Off
0x0F	1111	High	High	On	On

Modbus Error:

Function code (1 Byte): 0x81

Exception code (1 Byte): 0x01 or 0x02

Exception codes:

0x01 - Function code not supported

0x02 - Incorrect starting address/quantity of outputs combination

Character String Example:

```
char read_coils_mb_response[] = {0x00, 0x01, 0x00, 0x00, 0x00, 0x04, 0xff,
0x01, 0x01, 0x01};
```

### 3.4.2 Read Discrete Inputs (Modbus Function Code 02 (0x02))

This function returns the state of the optically-isolated inputs.

#### Valid Starting Address and Quantity of Coils Combinations

Valid starting addresses can fall in the range of 0x0000 and 0x0001. Valid quantities can fall in the range of 0x0001 and 0x0002. The only restriction is that the sum of the starting address and the quantity of coils must not be greater than 0x0002. For example, if you want to read 0x0002 bits, both inputs, then the starting address must be 0x0000. On the other hand, you may want to read the second input only. This can be achieved by starting at address 0x0001 and using a quantity of 0x0001.

#### Request

Modbus/TCP:

Transaction identifier (2 Bytes): 0x0001



Protocol identifier (2 Bytes): 0x0000  
 Length (2 Bytes): 0x0006  
 Unit identifier (1 Byte): 0xff

**Modbus:**

Function code (1 Byte): 0x02 (read discrete input)  
 Starting address (2 Bytes): 0x0000 (0x0000 or 0x0001)  
 Quantity of inputs (2 Bytes): 0x0001 (0x0001 or 0x0002)

**Character String Example:**

```
char read_inputs_mb_request[] = {0x00, 0x01, 0x00, 0x00, 0x00, 0x06,
0xff, 0x02, 0x00, 0x00, 0x00,
0x01 };
```

**Response**

**Modbus/TCP:**

Transaction identifier (2 Bytes): 0x0001  
 Protocol identifier (2 Bytes): 0x0000  
 Length (2 Bytes): 0x0004  
 Unit identifier (1 Byte): 0xff

**Modbus:**

Function code (1 Byte): 0x02 (Read discrete input)  
 Byte count (1 Byte): 0x01  
 Input status: 0x00 (input off), 0x01 (input on)

Data Byte (hex)	LS Data Bits (binary)	Input 2 State	Input 1 State
0x00	0000	Low	Low
0x01	0001	Low	High
0x02	0010	High	Low
0x03	0011	High	High

**Modbus Error:**

Function code (1 Byte): 0x82  
 Exception code (1 Byte): 0x01 or 0x02

**Exception codes:**

- 0x01 - Function code not supported
- 0x02 - Incorrect starting address / quantity of outputs combination

**Character String Example:**

```
char read_inputs_mb_response[] = {0x00, 0x01, 0x00, 0x00, 0x00, 0x04,
0xff, 0x02, 0x01, 0x01 };
```

### 3.4.3 Read Holding Registers (Modbus Function Code 03 (0x03))

This function is used to read the amount of time that has elapsed, in seconds, since a voltage has been applied to an input. This value will continually increment as long as a voltage is applied. As soon as the voltage is removed it will stop. The remaining value will indicate the amount of time that elapsed while the voltage was applied. If a voltage is reapplied to an input, this register will reset to zero and begin the timing process again. The starting address for the input1hightime is 0x0014 and the start address for input2hightime is 0x0016.

Note that the time is provided in IEEE 754 floating point format. A quantity of two registers must be read at a time. The four data bytes are treated as two individual big endian 16-bit words but the least significant word is sent first. In other words, the 32-byte floating point number represented as ABCD is sent as CDAB. In the example shown below, input one has had a voltage applied to it for 5 seconds. Five seconds is represented using a floating point number of 40A00000. As you can see, it is transferred as 000040A0.

#### Request

##### Modbus/TCP:

Transaction identifier (2 Bytes): 0x0001  
 Protocol identifier (2 Bytes): 0x0000  
 Length (2 Bytes): 0x0006  
 Unit identifier (1 Byte): 0xff

##### Modbus:

Function code (1 Byte): 0x03 (read holding registers)  
 Output address (2 Bytes): 0x0014 (0x0016 for input 2)  
 Word Count (2 Bytes): 0x0002 (0x0004 if read value for both inputs)

#### Character String Example:

```
char read_registers_mb_request[] = {0x00, 0x01, 0x00, 0x00, 0x00, 0x06,
0xff, 0x03, 0x00, 0x14, 0x00, 0x02};
```

#### Response

##### Modbus/TCP:

Transaction identifier (2 Bytes): 0x0001  
 Protocol identifier (2 Bytes): 0x0000  
 Length(2 Bytes): 0x0007  
 Unit identifier (1 Byte): 0xff

##### Modbus:

Function code (1 Byte): 0x03 (read holding registers)  
 Byte Count (1 Byte): 0x04 (should always be 0x04)  
 Data (4 bytes): 0x000040A0 (IEEE 754 Floating Point Number Least Significant Word First.  
 0X40A00000 = 5.0 seconds)

##### Modbus Error:

Function code (1 Byte): 0x83  
 Exception code (1 Byte): 0x01 or 0x02

##### Exception codes:

0x01 - Function code not supported  
 0x02 - Incorrect starting address / quantity of outputs combination

**Character String Example:**

```
char read_registers_mb_response[] = {0x00, 0x01, 0x00, 0x00, 0x00,
0x07, 0xff, 0x03, 0x04, 0x00, 0x00, 0x40, 0xA0 };
```

**3.4.4 Write Single Coil (Modbus Function Code 05 (0x05))**

This function allows you to turn relays one and two on and off one at a time.

Request

## Modbus/TCP:

Transaction identifier (2 Bytes): 0x0001  
 Protocol identifier (2 Bytes): 0x0000  
 Length (2 Bytes): 0x0006  
 Unit identifier (1 Byte): 0xff

## Modbus:

Function code (1 Byte): 0x05 (write coil)  
 Output address (2 Bytes): 0x0000 or 0x0001 (relay 1 = 0x0000, relay 2 = 0x0001)  
 Output value (1 Byte): 0xff - turn relay on, 0x00 - turn relay off  
 Padding (1 Byte): 0x00

**Character String Example:**

```
char write_coil_mb_request[] = {0x00, 0x01, 0x00, 0x00, 0x00, 0x06,
0xff, 0x05, 0x00, 0x00, 0xff, 0x00};
```

Response

## Modbus/TCP:

Transaction identifier (2 Bytes): 0x0001  
 Protocol identifier (2 Bytes): 0x0000  
 Length(2 Bytes): 0x0006  
 Unit identifier (1 Byte): 0xff

## Modbus:

Function code (1 Byte): 0x05 (write coil)  
 Output address (2 Bytes): 0x0000  
 Output value (1 Byte): 0xff - relay on, 0x00 - relay off  
 Padding (1 Byte): 0x00

## Modbus Error:

Function code (1 Byte): 0x85  
 Exception code (1 Byte): 0x01 or 0x02

## Exception codes:

0x01 - Function code not supported  
 0x02 - Incorrect starting address / quantity of outputs combination

**Character String Example:**

```
char write_coils_mb_response[] = {0x00, 0x01, 0x00, 0x00, 0x00, 0x06,
0xff, 0x05, 0x00, 0x00, 0xff, 0x00 };
```

### 3.4.5 Write Multiple Coils (Modbus Function Code 15(0x0F))

This function allows you to control relays one and two simultaneously using one command.

#### Valid Starting Address and Quantity of Coils Combinations

Valid starting address can fall in the range of 0x0000 and 0x0001. Valid quantities can fall in the range of 0x0001 and 0x0002. The only restriction is that the sum of the starting address and the quantity of coils must not be greater than 0x0002. For example, if you want to control both relays, then the starting address must be 0x0000. On the other hand, you may want to control the second relay only. This can be achieved by starting at address 0x0001 and using a quantity of 0x0001.

#### Request

##### Modbus/TCP:

Transaction identifier (2 Bytes): 0x0001  
 Protocol identifier (2 Bytes): 0x0000  
 Length (2 Bytes): 0x0008  
 Unit identifier (1 Byte): 0xff

##### Modbus:

Function code (1 Byte): 0x0F (write coils)  
 Output address (2 Bytes): 0x0000 or 0x0001 (relay 1 = 0x0000, relay 2 = 0x0001)  
 Bit count (2 Bytes): 0x0001 or 0x0002 (control one relay or both relays)  
 Byte count (1 Byte): 0x01 (always 0x01)  
 Output value (1 Byte): 0x00 through 0x03 (bit 0 = relay 1, bit 1 = relay 2)

#### Character String Example:

```
char write_coils_mb_request[] = {0x00, 0x01, 0x00, 0x00, 0x00, 0x08,
0xff, 0x0F, 0x00, 0x00, 0x00, 0x02, 0x01, 0x03};
```

#### Response

##### Modbus/TCP:

Transaction identifier (2 Bytes): 0x0001  
 Protocol identifier (2 Bytes): 0x0000  
 Length(2 Bytes): 0x0006  
 Unit identifier (1 Byte): 0xff

##### Modbus:

Function code (1 Byte): 0x0F (write coils)  
 Output address (2 Bytes): 0x0000 or 0x0001 (relay 1 = 0x0000, relay 2 = 0x0001)  
 Bit Count (2 Bytes): 0x0001 or 0x0002 (control one relay or both relays)

##### Modbus Error:

Function code (1 Byte): 0x8F  
 Exception code (1 Byte): 0x01 or 0x02

##### Exception codes:

0x01 - Function code not supported  
 0x02 - Incorrect starting address / quantity of outputs combination

#### Character String Example:

```
char write_coils_mb_response[] = {0x00, 0x01, 0x00, 0x00, 0x00, 0x06,
0xff, 0x0F, 0x00, 0x00, 0x00, 0x02 };
```

### 3.4.6 Write Multiple Registers (Modbus Function Code 16 (0x10))

This is used to pulse the relays for a specified time. When the WebRelay-Dual™ receives this command, it immediately turns the specified relay coil on (if not on already) and starts the pulse timer. The pulse time is specified in the register value field and the time can range from 0.1 seconds to 86400 seconds (1 day). When the pulse time expires, the relay coil will be turned off. If a pulse time command is sent with a value greater than 86400, the pulse timer will be set to 86400. If a pulse time command is sent with a value less than 0.1, the pulse timer will be set to 0.1. If any commands are sent to the WebRelay-Dual™ (commands may be modbus, xml, html, or electrical input) before the pulse timer has expired, the pulse timer will be canceled immediately and the new command will be executed.

#### Valid address/quantity combinations

Writing to these registers requires that the address be in the range of 0x10 and 0x13. Also, the address must be evenly divisible by 2. In other words, only addresses 0x10 and 0x12 are valid addresses. When the address 0x10 is used, both relays can be sent pulse times (8 bytes), or just the first relay can be sent a pulse time (4 bytes.) If the address 0x12 is used, only relay 2 can be sent a pulse time (4 bytes.) Note that the pulse time is provided in IEEE 754 floating point format. The four data bytes are treated as two individual big endian 16-bit words but the least significant word is sent first. In other words, the 32-byte floating point number represented as ABCD is sent as CDAB. In the example shown below, the relay will pulse for 5 seconds. Five seconds is represented using a floating point number of 40A00000. As you can see, it is transferred as 000040A0.

#### Request

Modbus/TCP  
 Transaction identifier (2 bytes): 0x0001  
 Protocol identifier (2 bytes): 0x0000  
 Length (2 bytes): 0x000f  
 Unit identifier (1 byte): 0xff

#### Modbus:

Function code (1 Byte): 0x10 (Write Multiple Registers)  
 Starting address (2 Bytes): 0x0010, or 0x0012  
 Number of registers (2 Bytes): 0x0002, or 0x0004  
 Byte count (1 Byte): 0x04, or 0x08  
 Registers value (4 Bytes or 8 Bytes): 00 00 40 A0 00 00 40 A0 (pulse both relays for 5 seconds)

#### Character String Example:

```
char write_registers_mb_request = {0x00, 0x01, 0x00, 0x00, 0x00, 0x0f,
0xff, 0x10, 0x00, 0x10, 0x00, 0x04, 0x08, 0x00, 0x00, 0x40, 0xA0, 0x00,
0x00, 0x40, 0xA0};
```

#### Response

##### Modbus/TCP:

Transaction identifier (2 Bytes): 0x0001  
 Protocol identifier (2 Bytes): 0x0000  
 Length (2 Bytes): 0x0006  
 Unit identifier: 0xff

##### Modbus:

Function code (1 Byte): 0x10 (Write Multiple Registers)  
 Starting address (2 Bytes): 0x0010 or 0x0012  
 Number of registers(2 Bytes): 0x0002 or 0x0004

Modbus Error:

Function code (1 Byte): 0x90

Exception code (1 Byte): 0x01 or 0x02

Exception codes

0x01 - Function code not supported

0x02 - Incorrect starting address / byte count combination

Character String Example:

```
char write_registers_mb_response[] = {0x00, 0x01, 0x00, 0x00, 0x00,  
0x06, 0xff, 0x10, 0x00, 0x10, 0x00, 0x04 };
```

## 3.5 Email Notification

### 3.5.1 Email Notification Description

WebRelay-Dual™ can be configured to send an email message to up to five email addresses when certain events happen. Events that can trigger email messages include input state changes, relay state changes, and commands sent from a BASIC script.

When an email message is sent, it looks similar to this:

**WebRelay-Dual**

Trigger: **Input 1: ON**

**Input 1: ON**

**Input 2: OFF**

**Relay 1: OFF**

**Relay 2: ON**

*Note: Everything shown in bold is text that is set by the user (installer).*

#### Subject Line

The top line (that reads WebRelay-Dual), appears in the subject line of the email message. This is the same text that appears as the header on the Control Page. It is set in the **Main Header Text** field under the **Control Page Setup** tab.

#### Trigger

The first line displayed in the body of the message shows what triggered the message. The text "Trigger" will always appear and cannot be changed. The remaining text includes the trigger, and the current state of that input or relay. The text that describes the trigger and its current state are configured in the setup pages as described below.

#### Current Status of Inputs and Relays

The remainder of the email message will display the same information shown on the **Control Page**. Any information omitted from the **Control Page** will not be included in the email message. If neither input or relay is displayed on the **Control Page**, the email message will not include anything except the Subject Line and the Trigger. The name for each input and relay is defined in the 'Description' fields for the inputs and relays. The text that describes the current status of the inputs and relays is defined in the 'On Status Text' and 'Off Status Text' within the setup tabs for the inputs and relays.

### 3.5.2 Email Notification Setup

Email notification requires that the following fields are properly set. See Section 2 for a description of each field.

**Network Tab:**

IP Address

Subnet Mask

Gateway

Preferred DNS Server (this is required if Mail Server is entered by name and not by IP address)

Mail Server (SMTP)

Mail Server Port

User Name (If Required)

Password (If Required)

Return Email

Email 1: (additional Email addresses may be entered)

Once the settings under the **Network** tab are entered correctly, an email trigger (or triggers) must be configured. An email trigger can be generated with a BASIC script (see **Appendix G: BASIC Scripts** for information about BASIC scripts), or can be explicitly defined for each input or relay (under **Inputs** and **Relays** tabs). For each input or relay trigger, the 'Email Option' field should be set to the appropriate trigger. Finally, the appropriate email addresses should be selected for each input and relay trigger by checking the box next to the desired email address under the **Inputs** and **Relays** tabs.

Once the email settings are entered, the email functionality can be tested by entering the following command.

```
http://192.168.1.2/state.xml?testEmail=1
```

This will cause an email message to be sent immediately. If the message doesn't get through, the system log file (<http://192.168.1.2/syslog.txt>) may have some clues to assist in diagnosing the problem.



## Appendix A: Restoring Factory Default Settings

In the event that the IP address or passwords are forgotten, WebRelay-Dual™ may be restored to its original factory default settings. To do this, first remove the power from the unit. Next, carefully insert a thin object (such as a toothpick) through the small hole in the bottom of the unit to press the small button that is located inside the unit. When the object is inserted, a tactile feel can be detected as the button is depressed. While holding the button down, apply power and wait for about 10 seconds. After about 10 seconds, release the button. Now all settings will be back to the original factory defaults.

**CAUTION: DO NOT USE METAL OBJECTS FOR THIS FUNCTION.**



*Figure Appendix A.1—Restore Factory Defaults*

## Appendix B: Installing New Firmware

From time to time, updates are made to the WebRelay-Dual™ firmware. The firmware can be updated in the field. The procedure for updating the firmware is outlined below. Please note that it is important that this procedure is followed precisely.

### Requirements

The firmware update software requires Windows XP/Vista/7 with the .Net framework installed. The .Net framework is generally installed automatically through Windows update. To install it manually, go to the following address:

<http://www.microsoft.com/downloads/details.aspx?FamilyId=333325FD-AE52-4E35-B531-508D977D32A6&displaylang=en>

Select the Download button. Once you've downloaded the installation file, double click on the installation file to install the framework.

### Setup

1. Download the firmware zip file (obtained from ControlByWeb support). Only a WebRelay-Dual™ image can be installed on WebRelay-Dual™ so make sure the correct image is being downloaded.
2. bootloader.exe will connect to the the WebRelay-Dual™ using default IP address 192.168.1.2, not the address currently assigned to the WebRelay-Dual™. After the update, all settings will be lost and the device will return to its default IP address of 192.168.1.2.

Configure the PC to the same subnet as the IP address 192.168.1.2, such as 192.168.1.10. For instructions on doing this see section **2.3 Establishing Communications for Setup**.

*Note: The IP address of WebRelay-Dual™ will automatically be set to the default 192.168.1.2 during the update process.*

*Note: A crossover cable cannot be used during the update procedure, an ethernet switch will be necessary to properly update the firmware.*

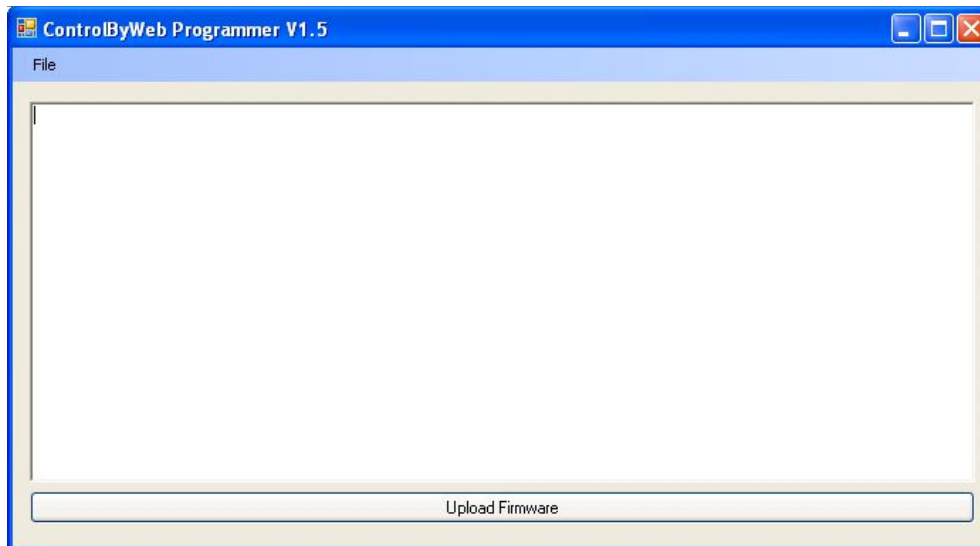

Figure Appendix B.1—Firmware Update Utility

3. Open the bootloader.exe utility on the computer by double clicking on the downloaded file (Figure Appendix B.1).
4. Within the ControlByWeb™ Programmer utility programmer, select File, then Open. Specify the firmware image downloaded from the ControlByWeb™ web site.

## Device Upgrade Procedure

Carefully follow the following steps to put the WebRelay-Dual™ into bootloader mode and perform the upgrade:

1. Remove DC power from WebRelay-Dual™.
2. Using a small, non-conductive tool, press and hold the reset button.
3. While holding the reset button, apply power to WebRelay-Dual™. The LINK and ACT lights will flash. Continue to hold the reset button for the next step.
4. While holding the reset button, press the Upload Firmware button at the bottom of the ControlByWeb™ Programmer window. After the programming process begins, the reset button can be released
5. Programming will take approximately 20-30 seconds, the LINK LED will stop flashing and remain lit. WebRelay-Dual™ will be set to factory defaults with an IP address of 192.168.1.2.
6. Refer to section **2.3 Establishing Communication for Setup** to reconfigure the WebRelay-Dual™. Verify the new version of firmware has been installed by viewing the default setup page with a web browser (<http://192.168.1.2/setup.html>).

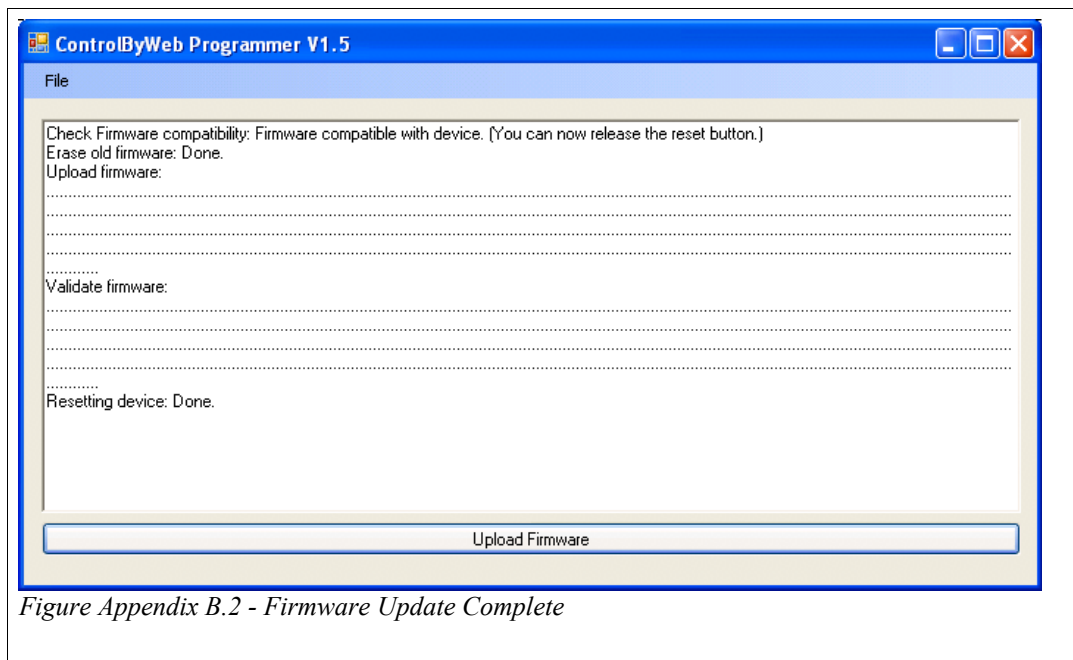

## Appendix C: Accessing WebRelay-Dual™ Over the Internet

WebRelay-Dual™ can be monitored and/or controlled from a remote location over the Internet. If access over the Internet is required, the WebRelay-Dual™ must be set up properly, and the router on the network where the WebRelay-Dual™ is installed must be configured for this. Note that once the WebRelay-Dual™ can be accessed on the local network, almost all of the settings required to provide remote access are in the router and not in the WebRelay-Dual™. This guide is not meant to be a tutorial in router setup, but rather to provide a basic overview of remote access. For specific details, the user should refer to the instruction manual for the router on his/her network. Users not familiar with basic IP networking should study one or more basic IP networking tutorials before proceeding (many tutorials are available on the Internet).

### IP Addresses

Every device on the Internet is identified by a unique address called an IP (Internet Protocol) address. IP addresses are somewhat similar to mailing addresses in that they identify the precise logical location of the device on the Internet. The IP address identifies the global region down to the network and then the specific device on that network. IP addresses are globally maintained and assigned by an entity called the Internet Assigned Numbers Authority (IANA). IP addresses consist of four numbers that range from 0 to 255 and are separated by a decimal. For example, 192.168.200.167 is an IP address.

Every device that is “directly” connected to the Internet uses a “public” IP address. Public IP addresses are addresses described in the paragraph above that identify a specific device on the Internet. The WebRelay-Dual™ can be assigned a public IP address for direct connection to the Internet. Typically, those who are reading this section of the manual would only assign a public IP address to the WebRelay-Dual™ when the WebRelay-Dual™ is the only device on the local network. The IP address would be obtained from the Internet Service Provider (ISP).

Due to the limited number of public IP addresses, private networks can be set up with “private” IP addresses. Private IP addresses are blocks of IP addresses that have been set aside for private use by anyone. These addresses have no global designation and are not routed on the Internet. The following address blocks are designated for private networks (where x represents decimal numbers from 0 to 255): 192.168.x.x, 10.x.x.x, and 172.16.x.x

### A Simple Local Area Network

A small Local Area Network (LAN), can be made up of two or more computers or other devices connected to an Ethernet switch. Each device on the network is assigned a unique private IP address. For example, consider a simple network that consists of a computer, an WebRelay-Dual™, and a WebRelay™. In this example, the computer is assigned an IP address of 192.168.1.10, the WebRelay-Dual™ has the IP address of 192.168.1.25 and a WebRelay™ has an IP address of 192.168.1.26. A person using the computer can access the WebRelay-Dual™ by entering its IP address in the URL line in the browser (<http://192.168.1.25>). The WebRelay™ can be accessed by entering its IP address in the URL line in the browser (<http://192.168.1.26>).

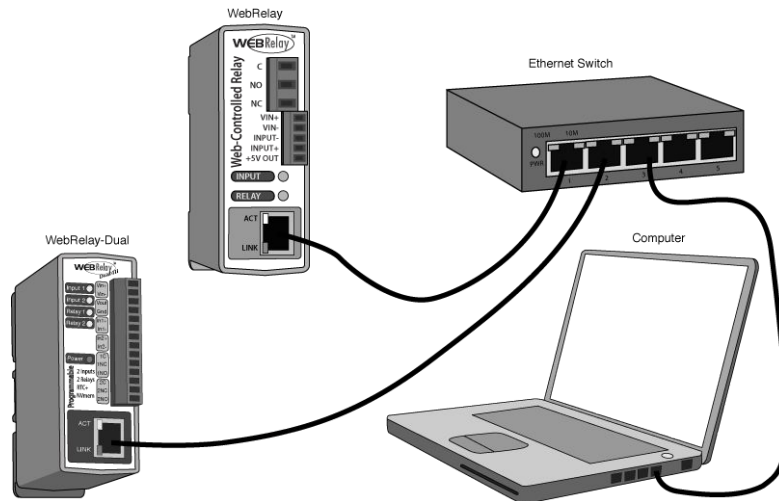

Figure Appendix C.1—Local Area Network

## A Simple LAN connected to the Internet

The LAN in the example above can be connected to the Internet by adding a router and an Internet connection. The router has two network connections. It has an Ethernet network connection that connects to the LAN, and it has another connection that connects to the Internet (this is called the WAN or Wide Area Network connection). Each network connection on the router has an IP address. In our example, the IP address on the LAN side of the router has an address of 192.168.1.1. The IP address on the WAN side of the router has an IP address that has been assigned by the Internet Service Provider such as 266.70.164.97 (note that this is not a valid IP address because each number cannot be larger than 255 but it is used in this example for illustration purposes only).

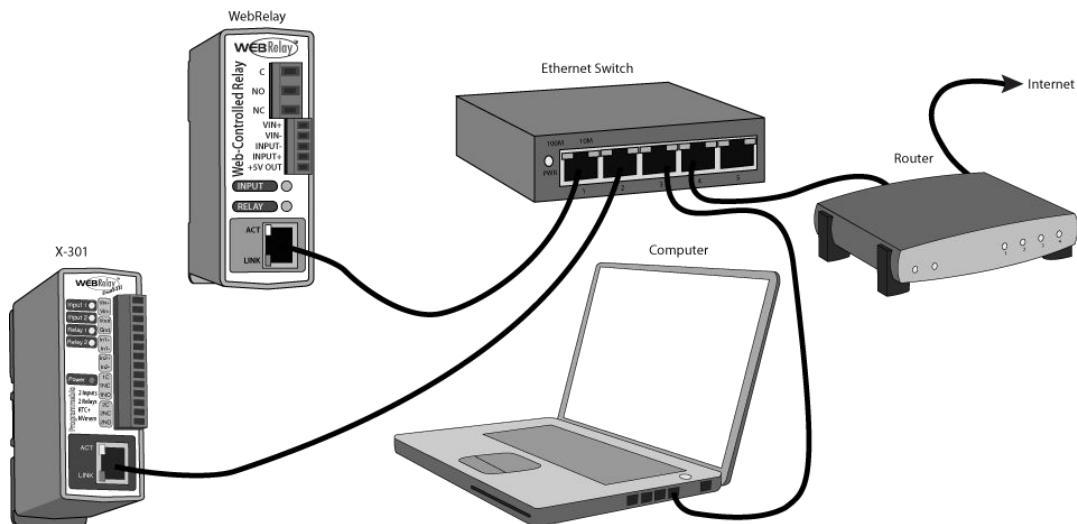

Figure Appendix C.2—LAN connected to the Internet

In the example, when a user on the computer needs to access a server on the Internet, the computer sends the request to the router at 192.168.1.1. The router sends the request to the server on the Internet. The server does not send the response directly to the computer on the LAN, but to the router at the IP address of 266.70.164.97. The router then forwards the response to the computer. This way, all devices on the LAN share a single public IP address. This is called Network Address Translation.

## Port Forwarding

The network can be configured to allow outside access to the WebRelay-Dual™ and the WebRelay™. All requests to any device on the network use the public IP address (266.70.164.97). With only a single IP address, TCP ports are used to identify the specific devices the incoming message should be sent to. Using the mailing address analogy, the port is similar to a post office box. The IP address specifies the location, and the port specifies the specific recipient. Port numbers can be set to any number between 1 and 65235 however many port numbers are reserved for specific applications and should be avoided. As a general rule, numbers above 8000 are safe to use. All of the ControlByWeb™ products come from the factory with the HTTP port set to 80 which is the standard port for HTTP. In this example, the WebRelay-Dual™ HTTP port will be changed to port 8000 and the WebRelay™ port will be changed to 8001. Once the ports are changed in the two ControlByWeb™ devices, the router must be set up for port forwarding. The way this is set up is specific to the router, but many routers use a table. Port forwarding setup associates the IP address of each device with the assigned port. In this example, the address 192.168.1.25 (WebRelay-Dual™) would be associated with port 8000. The address 192.168.1.26 (WebRelay™) would be associated with port 8001. By doing this, the WebRelay-Dual™ can be accessed from the Internet by entering the public IP address of the router, plus the port number assigned to the WebRelay-Dual™ in the URL window of the browser. For example, the user would enter `http://266.70.164.97:8000`. When the router receives this request, it would look in its port forwarding table to find out what to do with a request for port 8000. It would find that it should forward the request to the local address of 192.168.1.25 and then would forward the request. The WebRelay™ could be accessed the same way, except it would use port 8001 (`http://266.70.164.97:8001`).

Note that when an HTTP request comes in to the router without the specific port specified (`http://266.70.164.97`) the router will handle this as a port 80 request (default HTTP port). In other words, `http://266.70.164.97` is exactly the same as `http://266.70.164.97:80`.

An example screen shot of a router configuration is given below. This setup allows the two ControlByWeb™ products in the above example to be accessed remotely from the Internet. Note that this screen shot is simply an example of a typical router setup page. Routers will vary.

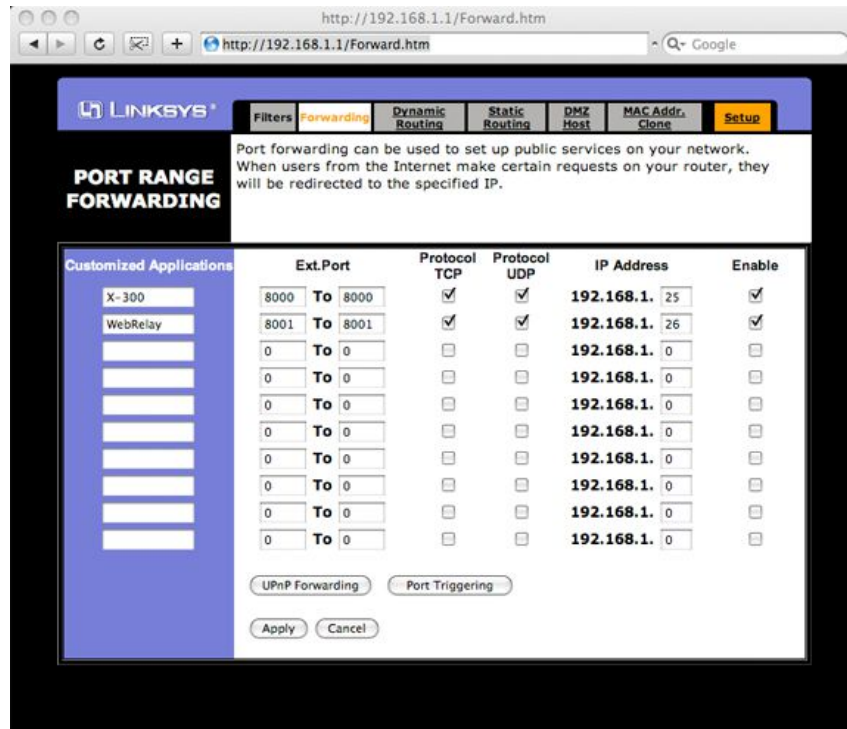

Figure Appendix C.3—Port Range Forwarding

## Accessing Setup Pages

After changing ports, the setup pages are accessed on local network as described below:

`http://(Local IP Address):(Port Number)/setup.html`

For example, To access the WebRelay-Dual™ in the setup page above, the following command would be used:

`http://192.168.1.25:8000/setup.html`

To access the ControlByWeb™ units from the Internet, enter the public IP address of the router plus the port number of the desired device in the following format:

`http://(Public IP Address of Router):(Port Number of Device)/setup.html`

Using the example above, the following line would be used to access the setup page of the WebRelay-Dual™:

`http://266.70.164.97:8000/setup.html`

## Appendix D: Log Files

The WebRelay-Dual™ logs information to two different log files; log.txt and syslog.txt. Both log files are text files and are stored in non-volatile memory and data will not be lost due to power failure. The log files are stored in circular buffers which write from the beginning of the allocated memory space to the end, and then repeat from the beginning (over-writing the original data). The non-volatile memory is divided into 4K byte sectors. Each time data gets erased to make room for new data, a full sector (4K bytes) is erased at one time.

### Data log file – log.txt

This log file is user configurable and stores real-world data such as temperatures and events such as relay contact changes. It can be up to 200K bytes long, and is stored using a comma separated value formatting scheme.

#### File format:

```
MM/DD/YYYY HH:MM:SS, relay 1, relay 2, input 1, input 2
```

#### Date and Time Format:

MM - Month (1-12)  
 DD – Day (1-31)  
 YYYY – Year (1970 - 2106)  
 HH – Hour in 24 hour time (0 -23)  
 MM – Minutes (0-59)  
 SS – Seconds (0-59)

#### Sample File:

```
Date Time,R1,R2,I1,I2,Source
01/28/1970 19:24:07,1,0,0,0,XmlReq:(192.168.1.29 R)
01/28/1970 19:24:10,1,1,0,0,XmlReq:(192.168.1.29 W)
01/28/1970 19:24:19,0,1,0,0,XmlReq:(192.168.1.29 R)
01/28/1970 20:00:00,0,1,0,0,TimeLog:()
02/01/1970 18:53:22,1,0,0,0,Relay01:(on)
02/01/1970 18:53:23,0,0,0,0,Relay01:(off)
02/01/1970 18:53:22,1,0,0,0,Input02:(on)
02/01/1970 18:53:23,0,0,0,0,Input02:(off)
```

Relay1 and Relay2, and Input1 and Input2 will be displayed only if they are selected in the log setup. This file is read by requesting the log.txt file. For example, using the default IP address the following command would be used:

```
http://192.168.1.2/log.txt
```

The file can then be saved using the 'Save As...' option under the 'File' menu of the web browser. If the TCP port has been changed (not port 80), the port will be required to read the file. For example, using the default IP address, and port 8000, the log file would be read as follows:

```
http://192.168.1.2:8000/log.txt
```

To erase the file, use the following parameter in the in the address bar:

```
http://192.168.1.2/log.txt?erase=1
```

After erasing the file, it might be necessary to refresh the page. Note that if the control password is enabled in the setup pages, the password (control password) will be required to access this file.



## System log file– syslog.txt

The syslog file records various system events, which can be used for diagnostics and troubleshooting purposes.

### File Format:

```
MM/DD/YYYY HH:MM:SS, (category to which message applies): (message)
```

### Sample File:

```
01/02/2010 04:08:13 DEVICE: Power Up.
01/01/2010 00:41:05 DEVICE: Reset factory defaults.
```

Listed below is a description of messages that a user may see:

Category	Message	Description
DEVICE	Power Up	Device has been properly powered.
	Initialize	Device is ready.
	Reset Factory Defaults	Device has been reset to factory defaults.
EMAIL	Failed DNS Lookup	Unable to lookup mail server due to an incorrect DNS setting.
	Bad Username	Email was not sent due to an incorrect user name.
	Bad Password	Email was not sent due to an incorrect password.
	Authentication Required	A user name and password are required by the mail server.
	No Response	No response from SMTP server.
CLOCK	RTC Reset	Real Time Clock has been reset.
NTP SERVER	Request Attempt	Device attempting to connect to NTP Server
	Failed DNS Lookup	Unable to lookup NTP server name due to an incorrect DNS setting.
	Success	Device successfully connected to NTP Server.
REMOTE SERVER	Failed DNS Lookup	Unable to lookup Remote Server due to an incorrect DNS setting.
	Connection Attempt Started	Connection port with Remote Server has been opened.
	Connection Closed	Connection port with the Remote Server has been closed.
DHCP	Address Acquired	IP address request successful, and IP address assigned.
	Lease Renewal	IP address assigned to device was renewed.
MAIN_MCU	New Firmware Loaded	New firmware has been loaded to the device.

This file is read by requesting the syslog.txt file. For example, using the default IP address the following command would be used:

```
http://192.168.1.2/syslog.txt
```

*Note: The setup user name and password are required to access this file.*

If the TCP port has been changed (not port 80), the port will be required to read the file. For example, using the default IP address, and port 8000, the log file would be read as follows:

```
http://192.168.1.2:8000/syslog.txt
```

To erase the file, use:

```
http://192.168.1.2/syslog.txt?erase=1
```

## Appendix E: External Server and Remote Services

*Note: The following methods are supported by WebRelay-Dual™; however, Xytronix Research & Design, Inc. does not provide or support custom third party applications, or external web servers.*

### Accessing WebRelay-Dual™ with Custom Software or Third Party Applications

Custom applications can send commands to WebRelay-Dual™ for monitoring and control functions using XML. (See **3.2 XML Operation** for more information.) The application interface can be used to provide a custom user interface, access to multiple units in a single screen, and allow for automation, logging, and other application-specific features.

### Using an External Web Server

Rather than accessing WebRelay-Dual™ directly from a computer, an external web server can be used. The term “external” web server is used here to mean a separate web server (such as Apache or IIS) that is not the web server built into WebRelay-Dual™. In this scenario, users access custom web pages that reside on the external web server and the external web server communicates with WebRelay-Dual™.

An external web server can integrate multiple ControlByWeb products into a single control page. In other words, the user may not be aware that he/she is using multiple ControlByWeb™ devices, but rather the user sees an integrated control page for the entire system. In addition, the use of an external web server allows programmers to create custom user interfaces that take advantage of the additional resources typically available on larger web servers, including more memory and various web programming languages.

There are two approaches that an external server can use to communicate with WebRelay-Dual™ and other ControlByWeb™ devices, Direct Server Control and Remote Services.

### Direct Server Control

The first approach is for the external server to create a TCP connection whenever it needs to access WebRelay-Dual™. In this case, the external server opens the connection, sends commands and/or reads the device, and closes the connection.

This method is ideal when the web server and all of WebRelay-Dual™ devices are on the same network (without routers between them). In this case, the server can communicate with WebRelay-Dual™ devices directly and securely since data never has to leave the local network.

When the server and WebRelay-Dual™ are on different networks, routers must be configured to allow appropriate access. If a public network is used, such as the Internet, security precautions should be considered.

### Remote Services

The second approach is for WebRelay-Dual™ to initiate a connection using the “Remote Services.” The settings under the **Advanced Network** tab in the setup pages will enable the X-320™ to open a TCP connection with an external server. Once the connection is open, the external server can send commands and/or read the device. The external server can leave the connection open (so that it never closes) or close the connection.

“Remote Services” is ideal for installations where the server and WebRelay-Dual™ are installed on different networks. This is especially useful when each

WebRelay-Dual™ is installed on a separate private network. For example, if the user doesn't control the

network connections where WebRelay-Dual™ is installed, “Remote Services” would initiate a TCP connection over the Internet with the control computer. Since WebRelay-Dual™ initiates the connection, the control computer doesn't have to know the IP address of WebRelay-Dual™. This means that WebRelay-Dual™ can be installed using DHCP. In addition, no special router configuration is required. This makes the network installation of WebRelay-Dual™ very simple, and since no incoming ports need to be opened in the router, security is not compromised. See section **2.4.3 Advanced Network Tab** for more information.

WebRelay-Dual™ can be configured to establish a connection when triggered by an event, such as a Relay state changing. This is done by setting the Remote Service/SNMP checkbox in the **Relay** setup tab.

When an event occurs and a connection is open, the state.xml file is sent.

If a connection is not open and Remote Services is enabled, a connection will be established by sending the connection string. Once the connection is established state.xml will be sent.

## Connection String

With Remote Services enabled, a connection attempt will be made periodically according to the Connection Interval setting in the **Advanced Network** setup tab. The Connection String is a user-defined character string configured in the **Advanced Network** tab.

The connection string is also sent at the same interval once the connection is open. The external server is responsible for closing the connection when it is done.

## Appendix F: SNMP Requests, Objects, and Community Strings

Using SNMP, some simple network parameters, relay states, and input states of the WebRelay-Dual™ can be retrieved. The states of the relays can also be changed through SNMP SET requests when the device is configured correctly. For most cases, using SNMP is as simple as locating the appropriate MIB files and loading them into the SNMP manager software. Once the MIB files have been loaded, information from the WebRelay-Dual™ can be accessed. The WebRelay-Dual™ can make use of the following MIB files: RFC1213-MIB, and XYTRONIX\_V1\_0.mib. Note: As new MIB file become available with support for other products, the older MIB files can be safely overwritten.

The WebRelay-Dual™ supports the following requests:

- GET
- GET NEXT
- SET
- TRAP

### Standard Objects

WebRelay-Dual™ supports several standard RFC1213 objects that usually come with SNMP management software. If not, an Internet search for RFC1213-MIB will turn up multiple links.

RFC1213 Object	Response
system.sysDescr	X301 - Event Scheduler/Relay Controller
system.sysObjectID	X301
system.sysUpTime	Time in hundredths of seconds since WebRelay-Dual™ was last powered.
system.sysName	X-301

\*The sysName is customizable under the **Control Page Setup** tab.

### Xytronix Objects

WebRelay-Dual™ also supports some special objects that can be found in the XYTRONIX.mib. This MIB can be downloaded from our website.

#### Read Only Objects:

#### Inputs

Object	Input Type	Response
webrelay_dual_inputOne	Digital	Value: 0 or 1 (0 – OFF, 1 – ON)
webrelay_dual_inputTwo	Digital	Value: 0 or 1

## Counters

Object	Response
webrelay_dual_counterOne	Value: 0.0 (Current count)
webrelay_dual_counterTwo	Value: 0.0 (Current count)

## Read/Write Objects:

### Outputs – Read/Write

A Get request will return the current state. A Set request of 0 or 1 will turn the Relay **ON** or **OFF**. A Set request of 2 will pulse the Relay for the time configured in the setup page.

Object	Response	Set Value
webrelay_dual_relayOne	Value: 0 or 1	0 - OFF, 1 - ON, 2 - PULSE
webrelay_dual_relayTwo	Value: 0 or 1	0 - OFF, 1 - ON, 2 - PULSE

## TRAPS

WebRelay-Dual™ can send SNMP messages when an Input or Relay changes state. The SNMP Trap must be configured for each Input and Relay in the setup pages. The following Traps are supported:

### Relay Traps

A change in state of the Output will cause the X-320™ to send a Trap message.

Object	Description	Value
webrelay_dual.75	Relay one state change.	0 or 1 (0 – OFF, 1 – ON)
webrelay_dual.76	Relay two state change.	0 or 1

### Input Traps

When an input on the X-320™ changes state, a Trap message will be sent.

Object	Description	Value
webrelay_dual.95	Input one state change.	0 or 1 (0 – OFF, 1 – ON)
webrelay_dual.96	Input two state change.	0 or 1

## Password

X-320™ uses the Control Password for both the read and write community strings. If the Control Password is disabled, any object can be read without the need for a correct community string. By default the Control Password is `webrelay`.

## Appendix G: BASIC Scripts

BASIC (Beginners All-purpose Symbolic Instruction Code) is a computer programming language that has been in use for many years. This ControlByWeb™ product has an integrated BASIC interpreter for simple BASIC scripts. This provides a great deal of flexibility by allowing users to customize basic functions of the unit. Note that the interpreter only supports a small subset of the BASIC commands that are available for computers. Note also, that some non-standard commands have been added, and some commands may function differently on the ControlByWeb™ BASIC interpreter than on other platforms. The following is a short tutorial on the supported BASIC functions. This tutorial is not meant as a tutorial for using the BASIC programming language and it assumes that the user has already had some experience with programming. For more information on programming in BASIC, tutorials can be found on the Internet. Note that this section is generic for all ControlByWeb™ and may contain some commands that do not apply to all products (for example temperature, analog, etc).

### Structure

A BASIC script is written as a .txt file, which is then uploaded to the device using the **Script** setup tab. The maximum script size is 2K bytes. Each line within the script contains a single statement. Line numbers are not used. Statements are not case sensitive, however, variables are. IF THEN, FOR loops, and DO loops can only be nested up to 5 times per command. For those not familiar with nesting the following is an example of nested FOR loops.

```
FOR a = 0 to 100
  FOR b = 0 to 100
    NEXT b
  NEXT a
```

Every program must end with an END statement. Subroutines would then follow after the the END statement, if required. The last line of the script should be left blank.

### Line Format

Every line follows the same format. The basic format is:

*statement (variable) (=, <, >, <=, >=, <>) (expression) (THEN)*

Where the fields in parentheses are optional depending on the statement. Spaces must be used between all statements, numbers, variables, operators, expressions, etc. Multiple spaces are valid.

Examples:

```
LET a=1           'this will return an error because of insufficient spacing
LET a = 1        'this is valid
LET a = 1        'this is valid
```

Only a single variable is allowed on the left side of any operator. The following example is incorrect and will return an error. The error occurs because there is more than a single variable to the left of the comparison operator (a + 2 is to the left of =).

```
IF a + 2 = 3 THEN
```

To fix the above line, replace 'a + 2.' One of the following options may be used:

```
IF a = 1 THEN
LET b = a + 2
IF b = 3 THEN
```

## Supported Statements

The following are the statements supported by the ControlByWeb™ BASIC interpreter, a short description of the statements and their formats.

### LET

The LET statement assigns a variable a value. The format is:

*LET (variable) = (expression)*

### IF THEN, ELSE, END IF

The IF THEN statement tests the truth of a condition. The ELSE statement defines a second function if the condition is found false. In other words, if the condition is true, then a function is preformed. If it is not true a second function may be preformed. The second function may or may not be necessary depending on the application. The IF THEN (ELSE) statement must always be followed with an END IF statement. The format is:

*IF (variable) (=, <, >, <=, >=, <>) (expression) THEN*  
*(Function 1)*  
*ELSE*  
*(Function 2)*  
*END IF*

*Note that in most BASIC interpreters 'Function 1' (see above) may be placed after the THEN statement. This interpreter requires 'Function 1' to be put on the following line.*

### FOR TO, NEXT

The FOR TO statement loops a section of code a predefined number of times. The NEXT statement always follows the section of code to be looped. The format is:

*FOR (variable) = (expression) TO (expression)*  
*(code to be looped)*  
*NEXT (variable)*

### DO WHILE, LOOP

The DO WHILE statement loops a section of code while a condition is found true. The LOOP statement always follows the section of code to be looped. Note that if the condition is omitted, the code will be looped without end. The format is:

*DO WHILE (variable) (=, <, >, <=, >=, <>) (expression)*  
*(code to be looped)*  
*LOOP*

**LOG**

The LOG statement causes the device to log data according to the settings specified under the **Logging** setup tab. Note that in order to log, logging must be enabled in the **Logging** setup tab. The format is:

*LOG*

**EMAIL**

The EMAIL statement causes the device to send an email. The format is:

*EMAIL (feature state – relayX, inputX, ) 'X represents the feature number such as relay2*

Examples:

```
EMAIL          'Status email sent to addresses listed under Network tab.
...or...
EMAIL relay2 'Sends state change message to emails setup in Relay tab.
...or...
EMAIL input1 'Input state change message to emails setup in Input tab.
```

**END**

The END statement ends the main body of code.

**CALL**

The CALL statement is found within the main body of code, but requires the interpreter to skip to a subroutine found at the end of the program. After the subroutine is finished, the interpreter returns to the line immediately following the CALL statement. The format is:

*CALL (name of subroutine)*

**SUB, END SUB**

The SUB statement defines the beginning and name of a subroutine. The END SUB statement defines the end of the respective subroutine. Subroutine names can be up to 20 characters long and are case sensitive. The SUB and END SUB statements always must follow the END statement. The format is:

```
END
SUB (name of subroutine)
(contents of subroutine)
END SUB
```

**REM OR '**

The REM (or ') statement designates remarks made by the programmer. The interpreter will disregard any characters following these statements.



## PRINT

The PRINT statement outputs a variable or message (if contained within quotation marks). Note that the PRINT statement is only available for the PC version of the BASIC interpreter. The device will not recognize the command. The format is:

*PRINT (variable) 'output variable value to screen*

*PRINT "(message)" 'output '(message)' to screen*

## User-Defined Variables

Two types of variables are available for use in the ControlByWeb™ BASIC interpreter - user defined variables, and useful predefined variables.

Up to 10 user defined variables are allowed to be used in scripts. Variables are represented by single, lower-case characters ranging from the letter 'a' to the letter 'j' in the English alphabet.

They are always global and stored internally as floating point numbers. Variables are defined using the LET statement.

Examples:

```
Let b = 5           'variable b will be set to 5
Let d = b + 2      'variable d will be set to 7
```

The following are useful predefined variables for the ControlByWeb™ BASIC interpreter. Note that some models may not contain digital inputs, analog inputs and/or relays and thus would not have digital input, analog input and/or relay variables.

## Predefined Variables

The following are useful predefined variables for the ControlByWeb™ BASIC interpreter. These are useful for accessing internal values and features states.

### Timer Variables

Six timers are available for use in BASIC scripts. They are designated as t0 through t5. Timers can be set to any positive integer (or 0) by using the LET statement. As soon as a value is assigned to a timer, it will begin to count down immediately by decrementing one count every 100ms until it reaches zero.

Examples:

```
Let t3 = 1500      'set timer 3 to 150 seconds
Let t1 = 0         'disable time 1
```

### Relay Variables

The internal relays can be turned on, turned off, pulsed, toggled, or read in BASIC scripts. The LET statement is used to set the relay state. The state options available are 0 (turn relay off), 1 (turn relay on), 2 (pulse relay), and 5 (toggle relay). Note that the relay pulse time is specified in the **Relays** setup tab. Relays are designated as relay1, relay2, relay3, etc.

**Examples:**

```

Let relay1 = 1      'turn on relay 1
Let relay2 = 0      'turn off relay 2
Let relay1 = 2      'pulse relay 1
Let relay2 = 5      'toggle relay 2
Let a = relay2      'read the state of relay 2, state will be 0 or 1

```

**Remote Relay Variables**

Remote relays can be turned on, turned off, pulsed, or toggled in BASIC scripts. Note: remote relays cannot be read (they will always return 0). In order for a remote relay to be used, it must first be set up using the Remote Relay settings in the **Relays** setup tab. The LET statement is used to set the remote relay's state. The states available for remote relays are the same as the internal relays. The relay pulse time is likewise specified in the **Relays** setup tab. The remote relays are designated as rmt\_relay1, rmt\_relay2, rmt\_relay3, etc.

**Examples:**

```

Let rmt_relay2 = 1  'turn on remote relay 2
Let rmt_relay1 = 0  'turn off remote relay 1
Let rmt_relay2 = 2  'pulse remote relay 2
Let rmt_relay3 = 5  'toggle remote relay 3

```

*Note: The remote relay states can only be changed as fast as the remote device can be updated. If the state is changed faster than the device can be updated, only the last state change will occur.*

**Digital Input Variables**

The input states can be read in BASIC scripts. The inputs are designated as input1, input2, input3, etc.

**Example:**

```

Let a = input1      'sets 'a' equal to value of input 1

```

**Input Counters**

The input counters can be set and read in the BASIC script using the count1 and count2 variables. These variables, when read, will return the current counter value for the corresponding input. The counters can also be set/reset through the BASIC script using the Let command. Since the BASIC interpreter considers all variables to be floating point numbers, the maximum value that these variables will return in the BASIC script is 16,777,216 even if the actual counter value is greater than this. (The counters will count to 4 billion, but any value past 16,777,216 will be read as 16,777,216.)

**Example:**

```

If count1 >= 100000 Then  'If counter 1 is greater than or equal
                          ' to 100000
Let relay1 = 1            'Turn relay 1 on
Let count1 = 0            'Reset counter 1
End If

```

## Analog Variables

The analog input scaled values can be read in BASIC scripts.

```
ana1      'analog input 1
...       'ana2, ana3
ana4      'analog input 4
```

Example:

```
If anal > 4 Then           'If Analog Input 1 is greater than 4 then
    Let relay1 = 2         'Pulse output 1, otherwise
Else
    Let relay1 = 0         'output1 will be off
End If
```

## Temperature/Humidity Sensor Variables

Each temperature sensor or humidity sensor can be read in BASIC scripts.

```
temp1     'temp or humidity sensor 1
temp2     'temp or humidity sensor 2
...       'temp3, temp4, temp5
temp6     'temp or humidity sensor 1
```

Example:

```
If temp2 >= 80 Then       'If temperature sensor reads greater than 80
                           ' degrees, then
    Let relay2 = 1         'Turn on relay 2
End If
```

## Date and Time Variables

The variables 'time' and 'date' are predefined, read only variables that store the current date and time. They can be used to schedule events and activities, such as sending emails, reading temperature, or setting Outputs. The date uses the mm/dd/yyyy format. Clock time is formatted as hh:mm:ss (24-hour clock).

Example:

```
If date = 01/01/2014 Then
    If time > 12:30:00 Then
        Let relay2 = 1
        Let relay3 = 0
    End If
End If
```

*Note: Current date and time can only be set in the **Date/Time** tab.*

## Event Variables

Actions can be configured to occur at specified days and times. Five events may be configured for the unit. This is done by setting the day and time of the event and then comparing it to the current date and time. Note that the current date and time must be set in the **Date/Time** setup tab. The event date variables are designated ed1 to ed5. They are set using the LET command and setting the desired event date variable equal to the date the event should occur in the format mm/dd/yyyy. The event time variables are designated et1 to et5. They are likewise set using the LET command and setting the corresponding event time variable equal to the event time in the format hh:mm:ss in 24 hour time. The event date variables store the number of days that have passed since January 1, 1970. The event time variables store the number of seconds from the beginning of the day. If the event time variable is incremented more than the number of seconds in a day (86400 seconds), the counter is reset to 0 and the event date variable is incremented by one. The variables 'time' and 'date' are predefined variables that store the current date and time and can only be read. They can then be used to compare the event date and times. The following example demonstrates defining the event variables and comparing it to the current date and time. Assume current time is April 10, 2009 at 1:30 AM and the event should occur in one hour and every hour thereafter.

Example:

```

Let a = 1
Let ed1 = 04/10/2009           'sets the event date to April 10,
                                '2009.
Let et1 = 02:30:00           'sets the event time to 2:30
Do While a <> 0
  If ed1 >= date Then         'Tests event date versus current date.
    If et1 >= time Then       'Tests event time versus current time.
      Let et1 = et1 + 3600 'Increments the event time by one hour
                              '(in seconds).
      Print "Event" 'Event to occur
    End If
  End If
End If
Loop
End

```

## External Variables

There are six external variables extvar0 through extvar5. External variables are similar to general purpose variables and can be used in the same manner. The difference between general purpose variables and external variables is that external variables can be accessed by the user through a web browser and modified while the script is running. Scripts can use external variables as a method of retrieving user input. External variables are stored in battery (capacitor) backed memory which will hold their value through short power disruptions. The following example demonstrates this by creating a script that will turn relay 1 on if extvar1 equals 1 and turn relay 1 off if extvar1 equals 0.

Example:

```

Do
  If extvar1 = 1 Then
    Let relay1 = 1
  Else
    Let relay1 = 0
  End If
Loop
End

```

Extvar1 can be set and cleared by entering the following requests into a web browser or by configuring on and off buttons to appear on the control page for extvar0:

```
http://192.168.1.2/state.xml?extvar1=1  
http://192.168.1.2/state.xml?extvar1=0
```

## Testing and Debugging

Note that a copy of the BASIC interpreter for Windows is also available on our website for the use of testing and debugging. The device will only acknowledge errors as it runs. This means that if a path of the script is not encountered, errors may still exist. The Windows version of the interpreter, however, will check for errors before the script is run. Note also that the PRINT function is available for use with the Windows version of the BASIC interpreter. The interpreter on the device, however, will not recognize this command.

*Note that the script will be restarted by submitting any of setup pages or by power cycling the unit*

## Examples

Following are a few examples of general applications that could be adapted for more specific use.

### Example 1: Flashing Lights

This script alternately pulses the two relays. If each relay is connected to a light, this script will alternately flash the lights (see section 1.5.3). The lights can be controlled from the event scheduler, the web control page, or by connecting buttons to the inputs. Two external variables are used to control when the script runs. When extvar0=0, both lights will be off. When extvar0=1, the lights will flash. When extvar1=1 the timer starts and the lights begin to flash (lights will flash until timer expires and then both lights will go off).

#### Inputs:

Pushbutton switches are tied to the inputs (only one shown in section 1.5.3). When the pushbutton switch tied to input 1 is pressed, it will cause the lights to start or stop flashing (toggles extvar0). When the pushbutton switch tied to input 2 is pressed, it will set extvar1 to 1 which will start the timer and the lights will flash for the duration of the timer.

#### Web Page:

By properly setting up the control page, users can control the lights using a web browser. To properly set up the web page, remove both inputs and relays from the control page (in setup pages). Enable control of extvar0 and extvar1 so that user can set and clear both external variables and name them properly.

#### Scheduling:

The flashing lights can be turned on and off by scheduling extvar0 to be set and cleared at the appropriate times. When extvar0 is set, the lights will flash. When extvar0 is cleared, the lights will stop flashing.

```

'Traffic Sign Script

Let t0 = 0          'Init second timer
Let t1 = 0          'Init min timer
Let a = 0           'timer on flag
Let b = 0           'pushbutton 1 flag
Let c = 0           'pushbutton 2 flag
Let d = 600        'How long to run min timer in 10ths of a second - 60 Sec * 10 = 600

Do

  'Check for push button 1 press
  If input1 = 1 Then
    Let b = 1          'set flag - input1 pressed
  Else
    If b = 1 Then     'if input1 was pressed then
      If extvar0 = 0 Then 'toggle extvar0
        Let extvar0 = 1
      Else
        Let extvar0 = 0
      End If
    End If
    Let b = 0        'reset flag
  End If
End If

  'Check for push button 2 press
  If input2 = 1 Then
    Let c = 1          'set flag - input2 pressed
  Else
    If c = 1 Then     'if input2 was pressed then
      Let extvar1 = 1 'Start min timer
      Let c = 0       'reset flag
    End If
  End If

  'If extvar1 = 1 then start min timer and start lights flashing
  If extvar1 = 1 Then
    If a = 0 Then
      Let a = 1          'Set var a to indicate timer on
      Let extvar0 = 1    'Start flashing
      Let t1 = d         'Start min timer
    Else
      If t1 <= 0 Then   'If timer expired
        Let a = 0      'Clear vars
        Let extvar0 = 0
        Let extvar1 = 0
      End If
    End If
  End If

  'flash lights ?
  If extvar0 = 1 Then
    Call flshLights     'Flash lights
  Else
    If t0 <= 0 Then
      Let relay1 = 0    'Turn lights off when timer is 0
      Let relay2 = 0    'Turn off relay 1
      Let t1 = 0        'Turn off relay 2
    End If
  End If

```

```
        End If

Loop

End

Sub flshLights

    'See if 1 sec has past
    If t0 <= 0 Then
        ' Reset 2/3 sec timer. (Timers decrement 10 times per second 2/3 of 10 = 7)
        Let t0 = 7

        'Toggle relays
        If relay1 = 1 Then
            Let relay1 = 0
            Let relay2 = 1
        Else
            Let relay1 = 1
            Let relay2 = 0
        End If
    End If

End Sub
```

## Example 2: Door Lock Script

WebRelay-Dual™ can be configured to lock and unlock electrical locks at specified times. If the lock is connected to relay 1 and a door sensor is connected to input 1, the following script can be used to trigger email messages only when the door is opened AND the lock is enabled. This eliminates numerous email messages that could be sent when the door is opened during daylight hours when it is unlocked.

```
'Door lock email
Let extvar1 = 0      'flag indicating the door was opened while locked
Do
If extvar1 = 0 Then
    If input1 = 1 Then
        If relay1 = 1 Then
            Let relay2 = 1
            Email input1
            Let extvar1 = 1
        End If
    End If
End If
Loop
End
```



## Appendix H: Specifications

### Power Requirements:

#### Voltage Input:

Model X-301-I : 9-28VDC

Model X-301-24I : 9-28VDC

Model X-301-E : Power Over Ethernet (48V injected into Ethernet line as per 802.3af specification)  
POE Class 1 (0.44Watt to 3.84Watt range) or 5VDC ±5%.

Network Speed (# of energized relays)	5 VDC (-E model with 5VDC applied)	9 VDC	12 VDC	24 VDC	28 VDC
10 Mbps (no relays)	180 mA	133 mA	92 mA	50 mA	44 mA
10 Mbps (2 relays)	348 mA	242 mA	175 mA	91 mA	79 mA
100 Mbps (no relays)	310 mA	207 mA	155 mA	81 mA	70 mA
100 Mbps (2 relays)	474 mA	324 mA	240 mA	123 mA	106 mA

#### I/O:

- 2 Relays, 2 Inputs

#### Relay Contacts:

- Contact Form: SPDT (form c)
- Contact Material: AgSnO2
- Contact Resistance: 100 milli-ohm max
- Internal Relay Mechanical Endurance: 10,000,000 operations min. (under no load)
- Internal Relay Electrical Endurance: 100,000 operations average (under rated load)
- Max Voltage: 28VAC, 24VDC
- Max Current: 3A

#### Optically Isolated Inputs:

- Voltage Range: 4-12VDC
- Voltage Range: (24-I model): (11-26VDC)
- Current: 4.7-25mA
- Minimum Hold Time (high or low): 20mS
- Maximum Count Frequency: 25Hz
- Input Functions: Monitor State, Control Relays, Control Remote Relays

#### Real-Time Clock:

- Manual or NTP (Network Time Protocol) setup
- NTP Sync Period: Once, Daily, Weekly, On Power-up
- Automatic Daylight Savings Adjustment
- Battery (capacitor) Power Backup

#### Capacitor Power Backup:

- Backup Functions: Retain Real-Time Clock, External Variables, Relay State.
- Backup Duration: 3 days minimum

**Nonvolatile Memory:**

- Memory Type: Flash
- Function: All user settings are stored in nonvolatile memory. Settings will not be lost when power is disconnected.

**Network:**

- 10 Base-T or 100 Base-T Ethernet Ipv4
- Static IP address assignment or DHCP
- HTTP port selectable
- Standard 8-pin RJ-45 Modular Socket
- Supports Web Browser (HTTP), XML, Modbus/TCP, SNMP protocols

**Connectors:**

- Power/Inputs: 14-position removable terminal strip with 3.81mm terminal spacing. For 16-28AWG wire. Requires 2.5mm flathead screwdriver. (Replacement part number, Phoenix Contact 1803691)
- Network: 8-pin RJ-45

**LED Indicators: 7**

- Module Powered
- Relay Coil Energized 1-2
- Inputs 1-2
- Network linked
- Network activity

**Environmental**

- Operating Temperature: -40°F to 150°F (-40°C to 65.5°C)

**Mechanical**

- 1.41in (35.7mm) wide x 3.88in (98.5mm) tall x 3.1in (78mm) deep (not including connector)
- Weight: 5.5oz (156 grams)

**Enclosure Material: Lexan 940**

- Flame rating UL94 V0

**Logging:**

- Storage: Nonvolatile Flash
- Buffer Architecture: Circular Buffer
- Log file size: 512K (max 28,829 logs)
- Unlimited data storage from Web Monitoring Service

**Advanced Features:**

- BASIC interpreter
- Remote services; Avoid most firewall issues with outbound connection to Web Services

**Password Settings:**

- Password protection on setup page: Yes
- Password protection on control page: Optional
- Password Encoding: Base 64
- Max password length: 13 characters

**Regulatory Compliance:**

- IEC CISPR 22, CISPR 24
- FCC 47CFR15 (-I and -5 Models class B, POE Model Class A)
- EU EN55024, EN55022

**Product Safety:**

- UL 61010-1 (Electrical Equipment for Measurement, Control, and Laboratory Use)



## Appendix I: Mechanical Information

