

Accessory Design Guidelines for Apple Devices

Release R13

Contents

Overview 13

1. Introduction 14

2. Requirements 15

3. Terminology 16

3.1 Device 16

3.2 Accessory 16

3.3 Captured Cable 16

3.4 Accessory Interface Specification 16

Accessories 17

4. All Accessories 18

4.1 Compliance Testing 18

4.2 Integrated USB Receptacles 18

4.3 User Supplied Cables and AC Power Adapters 18

4.4 Attachments 19

4.5 Magnetic Interference 19

4.6 Radio Frequency (RF) Performance 20

4.6.1 Materials and Coatings 20

4.6.2 Antenna Keep-Out 21

4.6.3 Over The Air (OTA) Transmission/Reception 21

4.6.4 Specific Absorption Rate (SAR) 21

4.6.5 Near Field Communication (NFC) 21

4.7 Qi Wireless Power 22

4.8 Thermal Management 22

4.9 Tripod Connections 23

5. Cases 24

5.1 Product Design 24

5.1.1 Device Protection 24

| | | |
|-----------|--|-----------|
| 5.1.2 | Access to Inputs and Interconnects | 25 |
| 5.1.3 | Dock Compatibility | 28 |
| 5.1.4 | Wireless Power and Rear Pockets | 28 |
| 5.2 | Acoustics | 29 |
| 5.2.1 | Call Quality | 29 |
| 5.2.2 | Speaker to Microphone Coupling | 29 |
| 5.2.3 | Speaker/Microphone Openings | 29 |
| 5.3 | Ambient Light Sensor and Proximity Sensor Interference | 32 |
| 5.4 | Taptic Engine | 32 |
| 5.5 | Magnetic Interference | 32 |
| 5.6 | Home Button / Touch ID Sensor | 33 |
| 5.7 | Camera | 33 |
| 5.7.1 | Geometry | 33 |
| 5.7.2 | Color | 34 |
| 5.7.3 | Surface Finish | 34 |
| 5.7.4 | Image Degradation Examples | 34 |
| 5.8 | Reliability | 35 |
| 5.8.1 | Device Insertion and Removal | 35 |
| 5.8.2 | Colorfastness | 35 |
| 5.9 | Environmental | 35 |
| 5.10 | Test Procedures | 36 |
| 5.10.1 | Device Models | 36 |
| 5.10.2 | Product Design | 43 |
| 5.10.3 | Taptic Engine | 45 |
| 5.10.4 | Home Button / Touch ID Sensor Overlays | 46 |
| 5.10.5 | Acoustics | 47 |
| 6. | Covers | 49 |
| 6.1 | Magnetic Interference | 49 |
| 6.2 | Smart Covers | 49 |
| 7. | Screen Overlays | 51 |
| 7.1 | Product Design | 51 |
| 7.2 | Edge Swipe and Edge Press Gestures | 51 |
| 8. | Camera Attachments | 52 |
| 8.1 | Magnetic Interference | 52 |
| 9. | Adapters | 53 |
| 9.1 | Headset Adapters (Lightning to 3.5 mm) | 53 |

- 9.2 USB-A/USB-C to Lightning Headset Adapters 53
- 9.3 Ethernet Adapters (Lightning to RJ45) 53
- 9.4 Lightning to USB Micro-B Adapters 54

- 10. AC Power Adapters** 55
 - 10.1 Converter Switching Frequencies 55
 - 10.2 YCAP AC Capacitor 55
 - 10.3 Impedance Stability 55
 - 10.4 Fuse Protection 56
 - 10.5 Short Circuit Response 57

- 11. Battery Packs** 58

- 12. Strobes** 59

- 13. AirPods Accessories** 61

- 14. Watch Bands** 62
 - 14.1 Requirements 62
 - 14.2 Example Apple Watch Lug Assembly 65

Features 68

- 15. Bluetooth Accessory Identification** 69
 - 15.1 HFP Command AT+XAPL 69
- 16. Accessory Power (Lightning)** 71
- 17. App Discovery** 72
- 18. App Launch** 73
- 19. App Match** 74
- 20. Bluetooth Headset Battery Level Indication** 75
 - 20.1 HFP Command AT+IPHONEACCEV 75
- 21. Device Power (Lightning)** 76
 - 21.1 Direct Power Source 76

- 21.2 External Power Source 76
- 21.3 Declaring Capability 77
- 21.4 Providing Power via USB Connectors 77
- 21.5 Labeling Multiple Connectors 78
- 21.6 Fast Charge for iPhone (18 W) 78
- 21.7 Overcurrent and Short Circuit Protection 79
- 21.8 Overcurrent and Short Circuit Protection Resets 80
- 21.9 Power State Changes 80

- 22. Location Information 81**

- 23. MagSafe Attach 82**
 - 23.1 MagSafe Case Magnet Array 83
 - 23.1.1 Product Design 83
 - 23.1.2 Mechanical 83
 - 23.1.3 Magnetic Interference 89
 - 23.2 MagSafe Accessory Magnet Array 89
 - 23.2.1 Product Design 90
 - 23.2.2 Mechanical 90
 - 23.3 Test Procedures 95
 - 23.3.1 MagSafe Case Magnet Array 95

- 24. Media Library Access 97**

- 25. Now Playing Updates 98**

- 26. Out-of-Band Bluetooth Pairing 99**

- 27. Siri 100**
 - 27.1 Enabling Custom Siri Commands 100
 - 27.2 Obtaining Siri Availability Information 100
 - 27.2.1 Obtaining Status Information at Connection 100
 - 27.2.2 Receiving Siri Availability Updates from the Device 101
 - 27.3 Initiating a Siri Session 102
 - 27.3.1 Initiating a Session from the Accessory 102
 - 27.3.2 Initiating a Session from the Device 103
 - 27.3.3 Ending a Session from the Accessory 104
 - 27.4 Siri Eyes Free Mode 104
 - 27.4.1 HFP Command AT+APLEFM 105
 - 27.5 Improving Voice Recognition 105

- 27.5.1 Wide Band Speech Support 106
- 27.6 Optimizing the Siri Experience 106
- 27.7 Common Siri Applications 106
 - 27.7.1 Initialization Procedure After Connection is Established 106
 - 27.7.2 Phone Dialing Using Siri 107
 - 27.7.3 Audio Routing and Media Playback Using Siri 108
 - 27.7.4 Turn-By-Turn Directions Using Siri 108
- 27.8 User Interaction with Siri Eyes Free in a Vehicle 108
- 27.9 Enabling/Disabling Siri from the Device 110
- 27.10 Test Procedures 111
 - 27.10.1 Siri Eyes Free 111

28. Wi-Fi Information Sharing 115

Protocols 116

29. USB Power Capability Vendor Request 117

30. USB D+/D- Resistor Networks 118

- 30.1 Electrical 118
- 30.2 Identifying Power Source Current Limit 119

31. USB Power Delivery 121

32. USB-C Current 122

33. Advanced Audio Distribution Profile (A2DP) 123

- 33.1 Bluetooth A2DP Specification 123
 - 33.1.1 AVDTP Transactions 123
- 33.2 SubBand Codec (SBC) 123
- 33.3 MPEG 2/4 AAC Codecs 124
- 33.4 Test Procedures 125
 - 33.4.1 Audio Quality 125
 - 33.4.2 Audio Switching 125
 - 33.4.3 HFP Interaction 125
 - 33.4.4 Siri 125
 - 33.4.5 Video Playback 125

34. iAP2 127

Transports 128

35. Bluetooth 129

- 35.1 Enhanced Data Rate 129
- 35.2 Adaptive Frequency Hopping 129
- 35.3 Sniff Mode for Low Power Consumption 129
- 35.4 Role and Topology Management 130
- 35.5 Extended Inquiry Response 131
- 35.6 Secure Simple Pairing 131
- 35.7 Pairing Button 132
- 35.8 Class of Device (CoD) 132
- 35.9 Link Supervision Timeout 132
- 35.10 Delay Reporting 133
- 35.11 Profiles 133
 - 35.11.1 Device ID Profile (DID) 133
 - 35.11.2 Service Discovery Protocol (SDP) 134
 - 35.11.3 Hands-Free Profile (HFP) 134
 - 35.11.4 Message Access Profile (MAP) 136
 - 35.11.5 Audio/Video Remote Control Profile (AVRCP) 136
 - 35.11.6 Advanced Audio Distribution Profile (A2DP) 139
- 35.12 Audio Routing 139
 - 35.12.1 Audio Data Received via HFP Profile 139
 - 35.12.2 Audio Data Received via A2DP Profile 139
- 35.13 HID 141

36. Bluetooth Low Energy (BLE) 142

- 36.1 Role 142
- 36.2 Advertising Channels 142
- 36.3 Advertising PDU 142
- 36.4 Advertising Data 142
- 36.5 Advertising Interval 143
- 36.6 Connection Parameters 144
- 36.7 Data Packet Length Extension 144
- 36.8 Privacy 145
- 36.9 Permissions 145
- 36.10 Pairing 145
- 36.11 MTU Size 146
- 36.12 Services 146
 - 36.12.1 Generic Access Profile Service 146

- 36.12.2 Generic Attribute Profile Service 146
- 36.12.3 Device Information Service 147
- 36.12.4 Available Services 147
- 36.13 GATT Server 147

Connectors 149

37. USB-A Receptacle 150

- 37.1 Mechanical 150
- 37.2 Electrical 150

38. USB-C Plug 151

- 38.1 Mechanical 151
- 38.2 Electrical 151
- 38.3 Test Procedures 152
 - 38.3.1 Connector Test ID 152
 - 38.3.2 Drawing Power 152

39. USB-C Receptacle 153

- 39.1 Mechanical 153
- 39.2 Electrical 153
 - 39.2.1 Drawing Power 153
 - 39.2.2 Providing Power 154
- 39.3 Test Procedures 154
 - 39.3.1 Connector Test ID 154
 - 39.3.2 Drawing Power 154
 - 39.3.3 Providing Power 155

References 156

40. Device Dimensional Drawings 157

- 40.1 iPhone 12 Pro Max 1 of 2 161
- 40.2 iPhone 12 Pro Max 2 of 2 162
- 40.3 iPhone 12 Pro 1 of 2 163
- 40.4 iPhone 12 Pro 2 of 2 164
- 40.5 iPhone 12 1 of 2 165
- 40.6 iPhone 12 2 of 2 166
- 40.7 iPhone 12 mini 1 of 2 167

| | |
|--|-----|
| 40.8 iPhone 12 mini 2 of 2 | 168 |
| 40.9 iPhone SE (2nd generation) | 169 |
| 40.10 iPhone 11 Pro Max | 170 |
| 40.11 iPhone 11 Pro | 171 |
| 40.12 iPhone 11 | 172 |
| 40.13 iPhone XS Max | 173 |
| 40.14 iPhone XS | 174 |
| 40.15 iPhone XR | 175 |
| 40.16 iPhone X | 176 |
| 40.17 iPhone 8 Plus | 177 |
| 40.18 iPhone 8 | 178 |
| 40.19 iPhone 7 Plus | 179 |
| 40.20 iPhone 7 | 180 |
| 40.21 iPhone 6s Plus | 181 |
| 40.22 iPhone 6s | 182 |
| 40.23 iPhone 6 Plus | 183 |
| 40.24 iPhone 6 | 184 |
| 40.25 iPhone 5s & iPhone SE | 185 |
| 40.26 iPhone 5c | 186 |
| 40.27 iPhone 5 | 187 |
| 40.28 iPad Air (4th generation) 1 of 5 | 188 |
| 40.29 iPad Air (4th generation) 2 of 5 | 189 |
| 40.30 iPad Air (4th generation) 3 of 5 | 190 |
| 40.31 iPad Air (4th generation) 4 of 5 | 191 |
| 40.32 iPad Air (4th generation) 5 of 5 | 192 |
| 40.33 iPad Pro (12.9-inch) 4th Generation 1 of 5 | 193 |
| 40.34 iPad Pro (12.9-inch) 4th Generation 2 of 5 | 194 |
| 40.35 iPad Pro (12.9-inch) 4th Generation 3 of 5 | 195 |
| 40.36 iPad Pro (12.9-inch) 4th Generation 4 of 5 | 196 |
| 40.37 iPad Pro (12.9-inch) 4th Generation 5 of 5 | 197 |
| 40.38 iPad Pro (11-inch) 2nd Generation 1 of 5 | 198 |
| 40.39 iPad Pro (11-inch) 2nd Generation 2 of 5 | 199 |
| 40.40 iPad Pro (11-inch) 2nd Generation 3 of 5 | 200 |
| 40.41 iPad Pro (11-inch) 2nd Generation 4 of 5 | 201 |
| 40.42 iPad Pro (11-inch) 2nd Generation 5 of 5 | 202 |
| 40.43 iPad (7th generation) & iPad (8th generation) 1 of 3 | 203 |
| 40.44 iPad (7th generation) & iPad (8th generation) 2 of 3 | 204 |
| 40.45 iPad (7th generation) & iPad (8th generation) 3 of 3 | 205 |
| 40.46 iPad Air (3rd generation) with Wi-Fi 1 of 3 | 206 |

| | |
|---|-----|
| 40.47 iPad Air (3rd generation) with Wi-Fi 2 of 3 | 207 |
| 40.48 iPad Air (3rd generation) with Wi-Fi 3 of 3 | 208 |
| 40.49 iPad Air (3rd generation) with Wi-Fi + Cellular 1 of 3 | 209 |
| 40.50 iPad Air (3rd generation) with Wi-Fi + Cellular 2 of 3 | 210 |
| 40.51 iPad Air (3rd generation) with Wi-Fi + Cellular 3 of 3 | 211 |
| 40.52 iPad mini (5th generation) with Wi-Fi 1 of 3 | 212 |
| 40.53 iPad mini (5th generation) with Wi-Fi 2 of 3 | 213 |
| 40.54 iPad mini (5th generation) with Wi-Fi 3 of 3 | 214 |
| 40.55 iPad mini (5th generation) with Wi-Fi + Cellular 1 of 3 | 215 |
| 40.56 iPad mini (5th generation) with Wi-Fi + Cellular 2 of 3 | 216 |
| 40.57 iPad mini (5th generation) with Wi-Fi + Cellular 3 of 3 | 217 |
| 40.58 iPad Pro (12.9-inch) 3rd Generation 1 of 3 | 218 |
| 40.59 iPad Pro (12.9-inch) 3rd Generation 2 of 3 | 219 |
| 40.60 iPad Pro (12.9-inch) 3rd Generation 3 of 3 | 220 |
| 40.61 iPad Pro (11-inch) 1 of 3 | 221 |
| 40.62 iPad Pro (11-inch) 2 of 3 | 222 |
| 40.63 iPad Pro (11-inch) 3 of 3 | 223 |
| 40.64 iPad Pro (12.9-inch) 2nd Generation with Wi-Fi | 224 |
| 40.65 iPad Pro (12.9-inch) 2nd Generation with Wi-Fi + Cellular | 225 |
| 40.66 iPad Pro (12.9-inch) 2nd Generation Magnet/Hall Effect Sensors 1 of 2 | 226 |
| 40.67 iPad Pro (12.9-inch) 2nd Generation Magnet/Hall Effect Sensors 2 of 2 | 227 |
| 40.68 iPad Pro (10.5-inch) with Wi-Fi | 228 |
| 40.69 iPad Pro (10.5-inch) with Wi-Fi + Cellular | 229 |
| 40.70 iPad Pro (10.5-inch) Magnet/Hall Effect Sensors 1 of 2 | 230 |
| 40.71 iPad Pro (10.5-inch) Magnet/Hall Effect Sensors 2 of 2 | 231 |
| 40.72 iPad (5th and 6th generation) with Wi-Fi + Cellular | 232 |
| 40.73 iPad (5th and 6th generation) Magnet/Hall Effect Sensors 1 of 2 | 233 |
| 40.74 iPad (5th and 6th generation) Magnet/Hall Effect Sensors 2 of 2 | 234 |
| 40.75 iPad Pro (9.7-inch) with Wi-Fi | 235 |
| 40.76 iPad Pro (9.7-inch) with Wi-Fi + Cellular | 236 |
| 40.77 iPad Pro (9.7-inch) Magnet/Hall Effect Sensors 1 of 2 | 237 |
| 40.78 iPad Pro (9.7-inch) Magnet/Hall Effect Sensors 2 of 2 | 238 |
| 40.79 iPad Pro (12.9-inch) 1st Generation with Wi-Fi | 239 |
| 40.80 iPad Pro (12.9-inch) 1st Generation with Wi-Fi + Cellular | 240 |
| 40.81 iPad Pro (12.9-inch) 1st Generation Magnet/Hall Effect Sensors 1 of 2 | 241 |
| 40.82 iPad Pro (12.9-inch) 1st Generation Magnet/Hall Effect Sensors 2 of 2 | 242 |
| 40.83 iPad mini 4 with Wi-Fi | 243 |
| 40.84 iPad mini 4 with Wi-Fi + Cellular | 244 |
| 40.85 iPad mini 4 Magnet/Hall Effect Sensors | 245 |

| | |
|---|-----|
| 40.86 iPad Air 2 with Wi-Fi | 246 |
| 40.87 iPad Air 2 with Wi-Fi + Cellular | 247 |
| 40.88 iPad mini 2 & iPad mini 3 with Wi-Fi | 248 |
| 40.89 iPad mini 2 & iPad mini 3 with Wi-Fi + Cellular | 249 |
| 40.90 iPad Air with Wi-Fi | 250 |
| 40.91 iPad Air with Wi-Fi + Cellular | 251 |
| 40.92 iPad mini with Wi-Fi | 252 |
| 40.93 iPad mini with Wi-Fi + Cellular | 253 |
| 40.94 iPad (4th generation) with Wi-Fi | 254 |
| 40.95 iPad (4th generation) with Wi-Fi + Cellular | 255 |
| 40.96 iPod touch (6th generation) & iPod touch (7th generation) | 256 |
| 40.97 iPod touch (5th generation) | 257 |
| 40.98 Apple Watch Series 6, 44 mm | 258 |
| 40.99 Apple Watch Series 6, 40 mm | 259 |
| 40.100 Apple Watch SE, 44 mm | 260 |
| 40.101 Apple Watch SE, 40 mm | 261 |
| 40.102 Apple Watch Series 5, 44 mm | 262 |
| 40.103 Apple Watch Series 5, 40 mm | 263 |
| 40.104 Apple Watch Series 5 Ceramic, 44 mm | 264 |
| 40.105 Apple Watch Series 5 Ceramic, 40 mm | 265 |
| 40.106 Apple Watch Series 4, 44 mm | 266 |
| 40.107 Apple Watch Series 4, 40 mm | 267 |
| 40.108 Apple Watch Series 3 Ceramic, 42 mm | 268 |
| 40.109 Apple Watch Series 3 Ceramic, 38 mm | 269 |
| 40.110 Apple Watch Series 3 Metal, 42 mm | 270 |
| 40.111 Apple Watch Series 3 Metal, 38 mm | 271 |
| 40.112 Apple Watch Series 2 Ceramic, 42 mm | 272 |
| 40.113 Apple Watch Series 2 Ceramic, 38 mm | 273 |
| 40.114 Apple Watch Series 2 Metal, 42 mm | 274 |
| 40.115 Apple Watch Series 2 Metal, 38 mm | 275 |
| 40.116 Apple Watch (1st generation) & Apple Watch Series 1, 42 mm | 276 |
| 40.117 Apple Watch (1st generation) & Apple Watch Series 1, 38 mm | 277 |
| 40.118 AirPods Pro Wireless Charging Case | 278 |
| 40.119 AirPods Wireless Charging Case | 279 |
| 40.120 AirPods Pro | 280 |
| 40.121 AirPods | 281 |
| Revision History | 282 |
| Added Content | 282 |

Updated Content 282

Overview

1. Introduction

Note: These Accessory Design Guidelines for Apple Devices ('Guidelines') are subject to the terms and conditions set forth on the final page of this document. By downloading, accessing, or otherwise utilizing these Guidelines, you agree to be bound by, and only utilize the Guidelines in accordance with, such terms and conditions.

These guidelines address:

- The physical design of cases, covers, screen overlays, and camera attachments for iOS devices.
- The specifications for hardware accessories that use the Bluetooth transport to communicate with iOS devices and Mac computers.
- The design of AC power adapters, battery packs, and Qi wireless power transmitters for iOS devices.
- The physical design of band accessories that are compatible with Apple Watch.

These guidelines do not address other aspects of accessory communication with iOS, iPadOS, tvOS, or watchOS devices. Instead, see the Apple MFi licensing program (<https://developer.apple.com/programs/mfi/>) and the [Accessory Interface Specification](#) (page 16).

2. Requirements

The use of the words *shall*, *shall not*, *required*, *prohibited*, *should*, *should not*, *recommended*, *not recommended*, *may*, *optional*, and *deprecated* in a statement have the following meanings:

- *shall*, or *required* means the statement is an absolute requirement.
- *shall not* or *prohibited* means the statement is an absolute prohibition.
- *should* or *recommended* means the full implications shall be understood before choosing a different course.
- *should not* or *not recommended* means the full implications shall be understood before choosing this course.
- *may* or *optional* means the statement is truly optional, and its presence or absence cannot be assumed.
- *deprecated* means the statement is provided for historical purposes only and is equivalent to 'shall not'.

3. Terminology

3.1 Device

Device refers to an iPhone, iPad, or iPod.

iOS device refers to an iPhone or iPod running iOS.

iPadOS device refers to an iPad running iPadOS.

Where appropriate, specific Apple product and operating system references will also be used.

3.2 Accessory

Accessory refers to any product that connects to a *device* via the interfaces described in this specification.

3.3 Captured Cable

A captured cable is a cable that has one end permanently attached to the accessory enclosure.

See the [Accessory Interface Specification](#) (page 16) for more information.

3.4 Accessory Interface Specification

The *Accessory Interface Specification* is available to members of the Apple MFi licensing program (<https://developer.apple.com/programs/mfi>).

Use of some features requires accessory developers to be a member of the Apple MFi licensing program and to integrate specific MFi hardware into the accessory.

Accessories

4. All Accessories

The requirements in this section apply to all accessories regardless of their feature sets.

4.1 Compliance Testing

Accessories shall not assume that evidence of functionality when attached to a device means the accessory is compliant with this specification. Such an approach does not account for future devices or software releases and runs a high risk of depending on un-documented device behavior that is subject to change at any time.

If available, accessories should validate their design and implementation using the recommended test procedures for all supported features.

4.2 Integrated USB Receptacles

Accessories that incorporate a USB receptacle for the purpose of drawing power from an external USB power source shall meet the following requirements:

- USB-B receptacles shall comply with the *USB Battery Charging 1.2* specification.
- USB-C receptacles shall comply with the requirements in [Drawing Power](#) (page 153).

4.3 User Supplied Cables and AC Power Adapters

Accessories that can reasonably be used with user-supplied cables and/or AC power adapters shall be designed to work with any cable, AC power adapter, or battery pack that is compliant with this specification, see [AC Power Adapters](#) (page 55), and [Battery Packs](#) (page 58), including Apple branded cables and AC power adapters. Such accessories shall not declare compatibility only with Apple branded USB cables or AC power adapters.

This compatibility requirement applies to all aspects of user-supplied cables and power adapters. For example:

4. All Accessories

4.4 Attachments

- Connector receptacles on accessories shall accommodate all spec-compliant connector overmolds, and any accessory opening surrounding the Lightning receptacle on a device shall provide sufficient clearance for spec-compliant connector overmolds.
- Accessories shall work with all cables that comply with the specification with regards to electrical DCR and SI.

Note: Such accessories shall be tested with a wide variety of spec-compliant cables (including various lengths of the same cable if applicable) and AC power adapters during accessory development, in addition to Apple branded cables and AC power adapters.

4.4 Attachments

Accessories shall remain compliant with the specification when connected to any attachments designed for that accessory.

Examples of accessory attachments include, but are not limited to:

- Car or desk mounts for a case accessory.
- Wireless charging mats for a Lightning dongle or case accessory.
- Detachable barcode scanners/credit card readers for a Lightning dock accessory.

4.5 Magnetic Interference

Apple recommends avoiding the use of magnets and metal components in accessories.

All accessories claiming compatibility with a device that has a digital compass (magnetometer) shall minimize interference with the digital compass and shall not repeatedly trigger compass recalibration.

All accessories claiming compatibility with a device that has rear camera autofocus (AF) and/or optical image stabilization (OIS) features shall not affect the operation of these features.

The following devices feature optical image stabilization:

- iPhone 12 Pro Max
- iPhone 12 Pro
- iPhone 12
- iPhone 12 mini
- iPhone SE (2nd generation)
- iPhone 11 Pro Max
- iPhone 11 Pro

4. All Accessories

4.6 Radio Frequency (RF) Performance

- iPhone 11
- iPhone XS Max
- iPhone XS
- iPhone XR
- iPhone X
- iPhone 8 Plus
- iPhone 8
- iPhone 7 Plus
- iPhone 7
- iPhone 6s Plus
- iPhone 6 Plus
- iPad Pro (12.9-inch) 2nd Generation
- iPad Pro (10.5-inch)

4.6 Radio Frequency (RF) Performance

This section contains RF performance requirements and recommendations for all accessories.

4.6.1 Materials and Coatings

Accessories should avoid use of:

- Metals
- Conductive materials or coatings
- Materials with high dielectric (permittivity >5 F/m)

Such materials absorb radio frequency energy and may impair or degrade the performance of antennas for cellular communication, GPS, Wi-Fi, Bluetooth, and NFC.

Examples include (but are not limited to) the following:

- Steel, aluminum, magnesium, titanium, etc.
- Plastics with any carbon content
- Plastics with any glass content
- Plastics with metallic plating
- Metallic paints
- Black paints with high carbon loading
- White paints with high titanium dioxide loading
- Metallic Physical Vapor Deposition (PVD) coatings

4. All Accessories

4.6 Radio Frequency (RF) Performance

4.6.2 Antenna Keep-Out

Antenna keep-out regions can be found in [Device Dimensional Drawings](#) (page 157).

Accessory materials or coatings that absorb radio frequency energy, see [Materials and Coatings](#) (page 20), in the antenna keep-out region have a higher risk of degrading device wireless performance.

4.6.3 Over The Air (OTA) Transmission/Reception

Accessories shall not excessively degrade the device's RF transmission efficiency. This can be quantified by measuring Total Radiated Power (TRP) across all of the device's operating bands.

Accessories shall not excessively degrade the device's RF reception sensitivity. This can be quantified by measuring Effective Isotropic Sensitivity (EIS) across all of the device's operating bands.

Accessories may have a higher risk of excessively degrading device RF performance if they:

- Contain magnets.
- Intrude on device [Antenna Keep-Out](#) (page 21) zones.
- Contain active electronic circuitry, such as:
 - Bluetooth radios.
 - Switched-mode power supplies.
 - High speed data interfaces.

All accessory configurations shall be taken into account when designing for maximum RF compatibility. Examples include, but are not limited to:

- Accessory on/off.
- Accessory open/closed.
- Attachment present/not present, see [Attachments](#) (page 19).

A list of labs that can perform OTA testing with devices is available. See the document "MFi Authorized Test Labs" in the "Technical Reference" section of the MFi Portal.

4.6.4 Specific Absorption Rate (SAR)

A list of labs that can perform SAR testing with devices is available. See the document "SAR Test Services" in the "Technical Reference" section of the MFi Portal.

4.6.5 Near Field Communication (NFC)

Accessories that intrude on device [Antenna Keep-Out](#) (page 21) zones and claim compatibility with a device with NFC shall not degrade device NFC transaction performance.

The following devices are NFC enabled:

4. All Accessories

4.7 Qi Wireless Power

- iPhone 12 Pro Max
- iPhone 12 Pro
- iPhone 12
- iPhone 12 mini
- iPhone SE (2nd generation)
- iPhone 11 Pro Max
- iPhone 11 Pro
- iPhone 11
- iPhone XS Max
- iPhone XS
- iPhone XR
- iPhone X
- iPhone 8 Plus
- iPhone 8
- iPhone 7 Plus
- iPhone 7
- iPhone SE
- iPhone 6s Plus
- iPhone 6s
- iPhone 6 Plus
- iPhone 6

4.7 Qi Wireless Power

Accessories that incorporate a Qi transmitter or receiver shall be certified according to *The Qi Wireless Power Transfer System, Power Class 0 Specification*, version 1.2.4, see <https://www.wirelesspower-consortium.com>.

4.8 Thermal Management

The accessory's supported temperature range shall be greater than or equal to the published temperature ranges of every device it claims compatibility with.

Accessories for iPhone should avoid raising iPhone's surface temperature above 37 °C.

4.9 Tripod Connections

Tripod connections shall comply with ISO 1222:2010.

5. Cases

Accessories that substantially enclose devices shall comply with the requirements stated in this chapter unless the accessory supports other features in this specification whose requirements conflict with the requirements in this chapter.

If the accessory has multiple user-detachable components that substantially enclose the device, the requirements and/or overrides shall be applied to each component separately.

5.1 Product Design

A well-designed case will securely house a device while not interfering with the device's operation. Significant factors in mechanical design include access to the device's sensors, controls, and connectors. Dimensional drawings for devices can be found in [Device Dimensional Drawings](#) (page 157).

5.1.1 Device Protection

Cases shall protect the device from a 1 m drop onto a hard paved surface in any device orientation.

Exposed glass on the device shall not come within 0.85 mm of a flat surface, such as a table or floor, in any orientation when the case is attached. It should not come within 1.00 mm.

Device protection should be achieved by either creating features around the exposed glass that will space it away from the flat surface or covering the exposed glass.

Care should be given to the design of the bottom of the case to achieve both device protection and access to device speakers, microphones, and connectors. For example, the bottom of iPhone X cases should:

- Not have an opening wider than 50 mm, see dimension A in [Figure 5-1](#) (page 25).
- Be made of polycarbonate (PC) at least 1.15 mm thick, see dimension B in [Figure 5-1](#) (page 25).

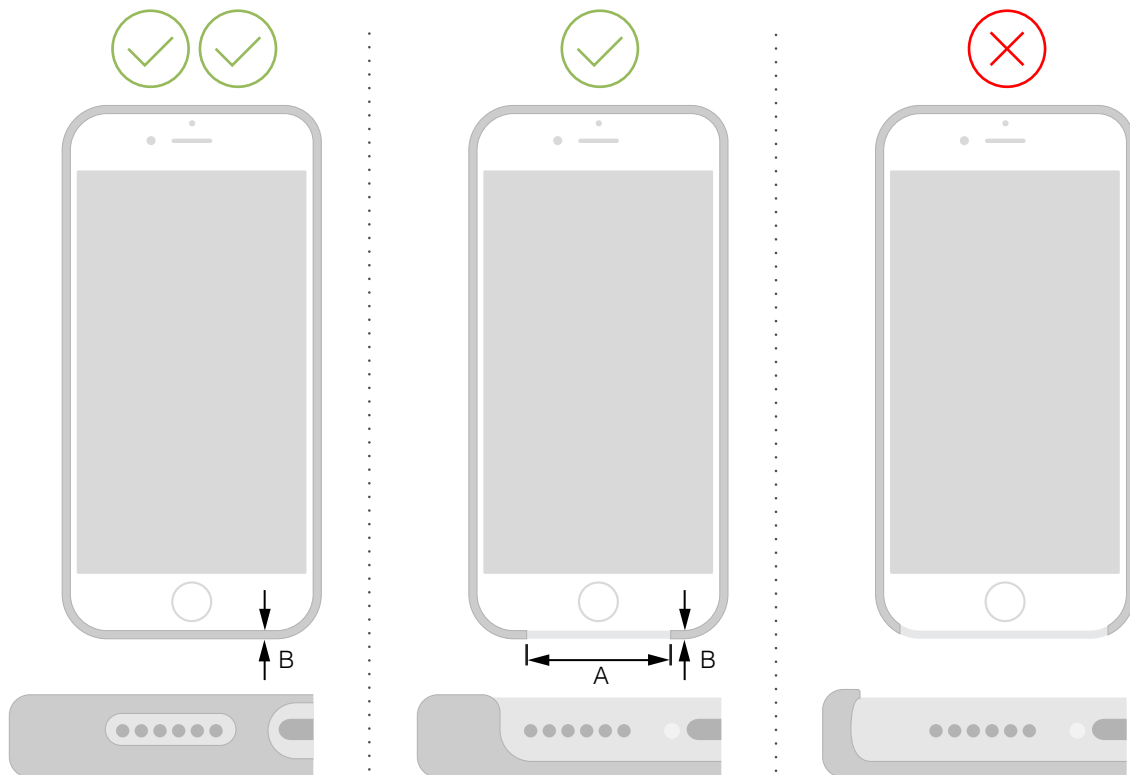
Figure 5-1 Device Protection

5.1.2 Access to Inputs and Interconnects

The accessory shall readily permit the user to access inputs and interconnects.

5.1.2.1 Access to Controls

The accessory shall readily permit the user to access and operate the device's mechanical controls, such as:

- Volume buttons
- Ring/Silent switch
- Side button
- Home/Touch ID sensor
- Home button
- Sleep/Wake button

5.1.2.2 Access to the Headset Jack

The case shall provide ready access to a device's headset jack (if present).

The headset jack opening (i.e., keep-out area):

5. Cases

5.1 Product Design

- Shall be at least 6.0 mm in diameter and at most 14.0 mm deep.
- Should be at least 6.5 mm in diameter and at most 10.0 mm deep for best compatibility with a range of headsets.

Headset jack openings shall be designed with enough margin to compensate for shifting or dimensional changes of the accessory material.

5.1.2.3 Access to the Lightning Connector

If the case is for a device with the Lightning connector, the opening (i.e., keep-out area):

- Shall be at least 12.05 mm by 6.30 mm with full radii rounded edges.
- Should be at least 13.65 mm by 6.85 mm for best compatibility with a range of cables and docks.

Lightning connector openings shall be designed with enough margin to compensate for shifting or dimensional changes of the accessory material.

5.1.2.4 Touchscreen

The accessory should not have any edges that can collect water on the touchscreen area when the device is held at a 30° angle relative to the horizon.

Accessories shall allow a 120° opening along the edges of the active area of the touchscreen to ensure compatibility with the device touchscreen features. See [Figure 5-2](#) (page 26) for more information on the keep-out and [Device Dimensional Drawings](#) (page 157) device specific active display areas.

Figure 5-2 Touchscreen keep-out area

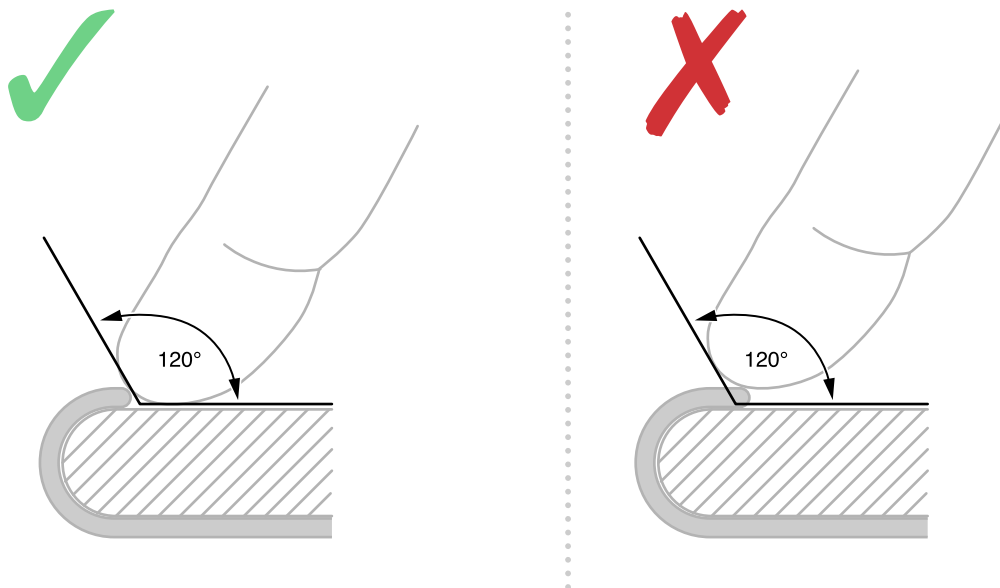

5.1.2.5 Edge Swipe Gestures

Users shall be able to easily use edge swipe gestures.

Examples of such gestures include, but are not limited to:

- Swipe in from the top edge for Control Center or Notification Center.
- Swipe in from the bottom edge for Home, App Switcher, or Reachability.
- Swipe in from the left edge in Messages or Mail to go back from a conversation.

The following devices make extensive use of edge swipe gestures in both portrait and landscape orientations:

- iPhone 12 Pro Max
- iPhone 12 Pro
- iPhone 12
- iPhone 12 mini
- iPhone SE (2nd generation)
- iPhone 11 Pro Max
- iPhone 11 Pro
- iPhone 11
- iPhone XS Max
- iPhone XS
- iPhone XR
- iPhone X
- iPad Air (4th generation)
- iPad Pro (12.9-inch) 4th Generation
- iPad Pro (11-inch) 2nd Generation
- iPad Pro (12.9-inch) 3rd Generation
- iPad Pro (11-inch)

5.1.2.6 Edge Press Gestures

Users shall be able to easily use edge press gestures.

The following devices support edge press gestures:

- iPhone 8 Plus
- iPhone 8
- iPhone 7 Plus
- iPhone 7
- iPhone 6s Plus
- iPhone 6s

An edge press gesture from the left is used to bring up the task switcher in iOS 9.0 and later.

5.1.2.7 Cover Glass Contact

Cases that claim compatibility with the following devices should not contact the cover glass as defined in their dimensional drawings:

- iPhone 12 Pro Max
- iPhone 12 Pro
- iPhone 12
- iPhone 12 mini
- iPhone SE (2nd generation)
- iPhone 11 Pro Max
- iPhone 11 Pro
- iPhone 11
- iPhone XS Max
- iPhone XS
- iPhone XR
- iPhone X
- iPhone 8 Plus
- iPhone 8
- iPhone 7 Plus
- iPhone 7
- iPhone 6s Plus
- iPhone 6s
- iPhone 6 Plus
- iPhone 6

See [Device Dimensional Drawings](#) (page 157).

5.1.3 Dock Compatibility

The distance from bottom of the device to the outside of a case should not exceed 1.8 mm. This improves compatibility with Lightning docks such as the Apple iPhone Lightning Dock.

5.1.4 Wireless Power and Rear Pockets

Cases that claim compatibility with MagSafe or the Qi wireless power feature in devices shall not have rear pockets or holders for credit cards, RFID cards, or other similar items. Cards may be damaged and/or impact wireless charging performance.

5.2 Acoustics

The accessory shall not impair or degrade the acoustic performance of a device.

5.2.1 Call Quality

The accessory shall not impair or degrade the user's experience making and receiving both audio calls over a cellular network or audio/video calls using FaceTime in both handset and speakerphone modes. The accessory should not change the frequency response of the speakers or microphones. In addition, the user should not hear any distortion or echo resulting from the accessory.

The accessory shall not obstruct any microphones during a phone call. Note that occluding any microphones can result in call quality degradation.

5.2.2 Speaker to Microphone Coupling

Cases shall not facilitate the conduction of sound from any speaker to any microphone. Such sound conduction may cause echoing in phone calls.

5.2.3 Speaker/Microphone Openings

Device speaker/microphone port locations vary from model to model, see [Device Dimensional Drawings](#) (page 157).

5.2.3.1 Thin Cases (≤ 2.25 mm)

Microphone/speaker openings in thin cases should:

- Be offset at least 2.0 mm from the edge of any device speaker/microphone port.
- Be at most 1.5 mm thick along their inner diameter.
- Have a maximum 45° incoming angle to their inner diameter.
- Maintain a proper seal against the device between speaker/microphone ports.

Figure 5-3 Microphone/speaker opening recommendations for thin cases

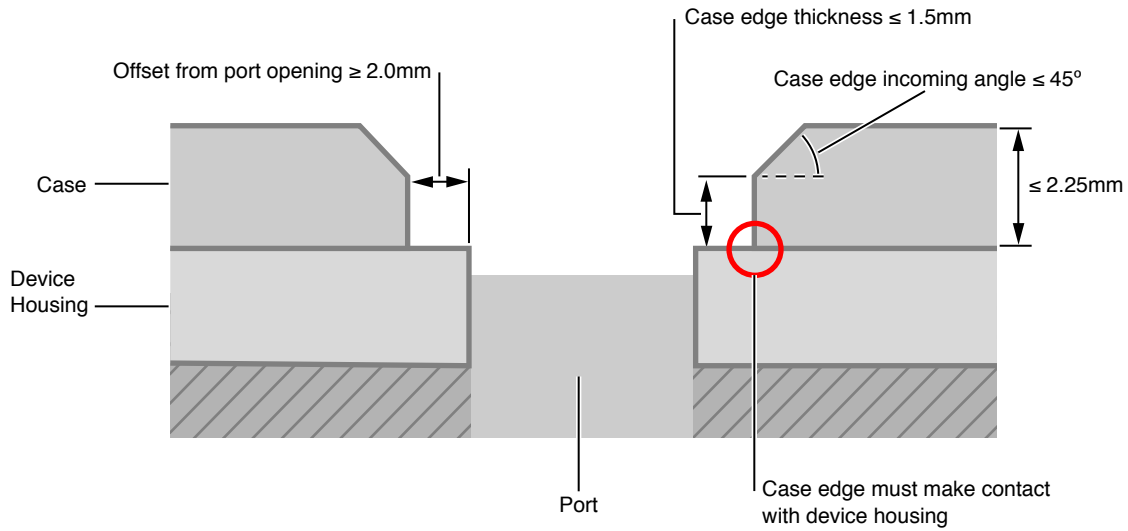

5.2.3.2 Thick Cases (>2.25 mm)

Speaker and microphone openings should be channeled independently and without interruption to/from the outside surface of a thick case.

Figure 5-4 Thick case acoustic channels

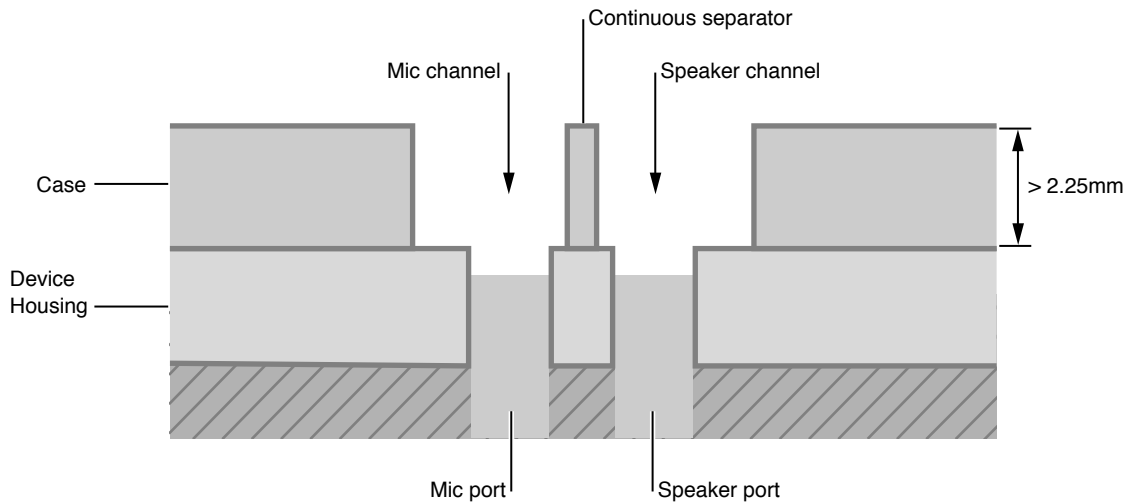

Thick cases should maximize exit separation between speaker and microphone channels.

Figure 5-5 Thick case microphone and speaker exit separation

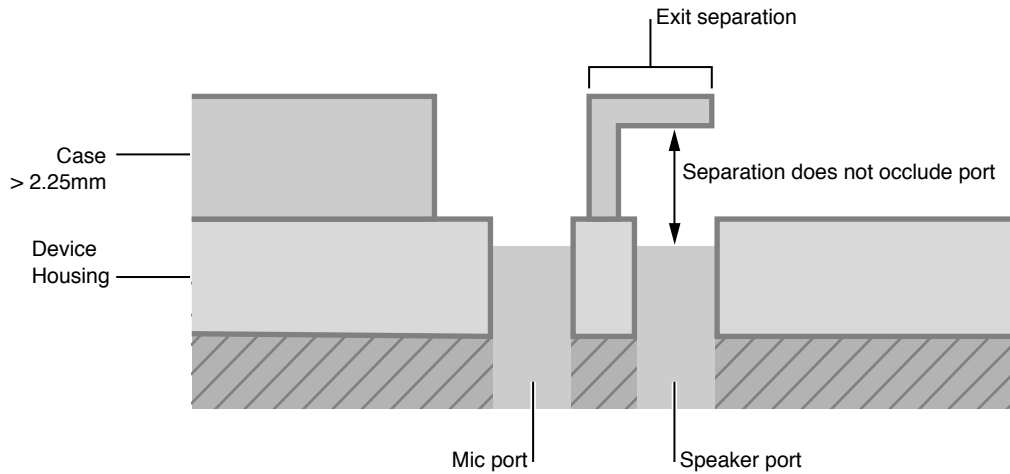

Thick case channels may act as a resonant chamber and detune microphone/speaker frequency response. The resulting frequency response may vary according to channel size/shape.

If a thick case does not maintain a proper seal against the device between microphone/speaker channels, the case itself may become an acoustic chamber.

Figure 5-6 Improper thick case seal

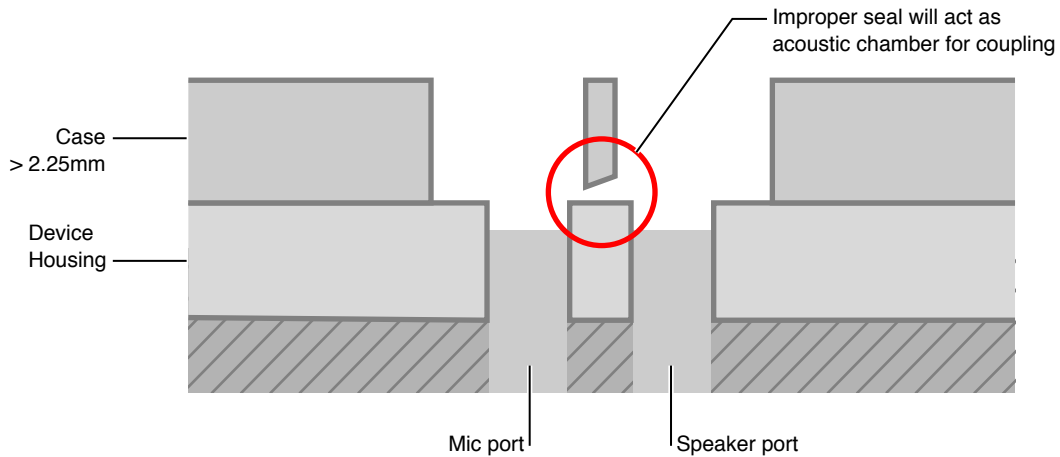

5.3 Ambient Light Sensor and Proximity Sensor Interference

The ambient light sensor and proximity sensor locations for various devices are shown in the dimensional drawings cited in [Device Dimensional Drawings](#) (page 157). Some of the dimensional drawings specify a recommended keep-out area around these sensors. No material shall be allowed to cover these sensors or their keep-out areas, this includes films and privacy screens. Accessories that allow the device to slide around shall not obstruct any sensors.

5.4 Taptic Engine

Accessories should not cause substantial change in the feel of the device's Taptic Engine.

The following devices contain a Taptic Engine:

- iPhone 12 Pro Max
- iPhone 12 Pro
- iPhone 12
- iPhone 12 mini
- iPhone SE (2nd generation)
- iPhone 11 Pro Max
- iPhone 11 Pro
- iPhone 11
- iPhone XS Max
- iPhone XS
- iPhone XR
- iPhone X
- iPhone 8 Plus
- iPhone 8
- iPhone 7 Plus
- iPhone 7
- iPhone 6s Plus
- iPhone 6s

5.5 Magnetic Interference

Cases shall not interfere with the device's:

- Magnetic compass.
- Rear camera autofocus.
- Rear camera optical image stabilization (OIS), if present.

See [Magnetic Interference](#) (page 19) for additional details.

5.6 Home Button / Touch ID Sensor

Accessories shall not inhibit use of the device's Home button / Touch ID sensor including features such as Touch ID fingerprint recognition.

Home button / Touch ID sensor keep-outs for devices can be found in [Device Dimensional Drawings](#) (page 157).

Additionally, accessories that overlay the iPhone SE (2nd generation), iPhone 8 Plus, iPhone 8, iPhone 7 Plus, and iPhone 7 Home button / Touch ID sensor may cause users to have difficulty using the Home button / Touch ID sensor.

5.7 Camera

The field of view (FOV) of the camera and the illumination provided by the flash are designed for each device camera. It is imperative that manufacturers consult technical specifications released for each device and do not assume these parameters are shared between devices.

Images from the camera may be affected by the geometry, color, and surface finish of the accessory openings for camera and applicable flash.

5.7.1 Geometry

The camera lens FOV shall not be blocked. Making the accessory opening too small around the camera and flash may block the FOV of the lens and the illumination from the flash. Blocking the FOV may cause vignetting in the image, where one or more corners of the image reproduced are darker than the center. Blocking marginal rays just outside the FOV of the lens may also reduce the sharpness and contrast of the image. Blocking the illumination from the flash may cause haze in the image, which resulting in reduced contrast. See [Device Dimensional Drawings](#) (page 157) for the camera keep-out.

The accessory opening shall not be designed in a way that directs stray light into the camera. If the opening is too narrow or too steep, it may reflect light into the camera, washing out the image or adding an unwanted color cast. Adding a chamfer to the accessory opening trim may help to direct stray light away from the camera. Additionally, where the product is equipped with a flash, a narrow or steep opening may reflect light from the accessory opening back into the camera. This may cause the image to appear washed out or contain unwanted artifacts. Designers should ensure that the mechanical keep-outs outlined in the [Device Dimensional Drawings](#) (page 157) are maintained with worst-case X-Y placement tolerances to minimize the risk of haze.

5.7.2 Color

Any light reflected from the accessory may pick up the color of the accessory. Black material or black coating may help avoid color bleeding into the camera from an external light source or the flash. The darker the color, the less light may be reflected from the source into the camera.

Note: Apple recommends a semi-gloss black material or coating around the camera and flash opening.

5.7.3 Surface Finish

The flash is a strong source of light and reflections from the camera accessory opening trim should be managed so that they do not reflect back into the camera. Semi-gloss material may direct light away from the camera. Matte or diffuse materials scatter light in all directions and will increase the likelihood that light from the flash or strong light sources in the scene is reflected into the camera.

5.7.4 Image Degradation Examples

Figure 5-7 Sample image degradation by image blocking in ambient condition

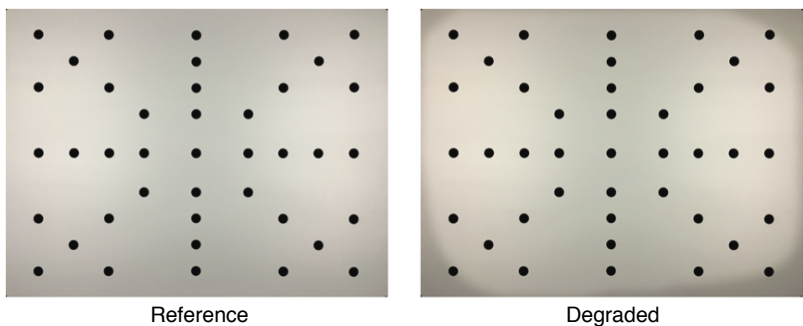

Figure 5-8 Sample image degradation by color shift through accessory with strong color

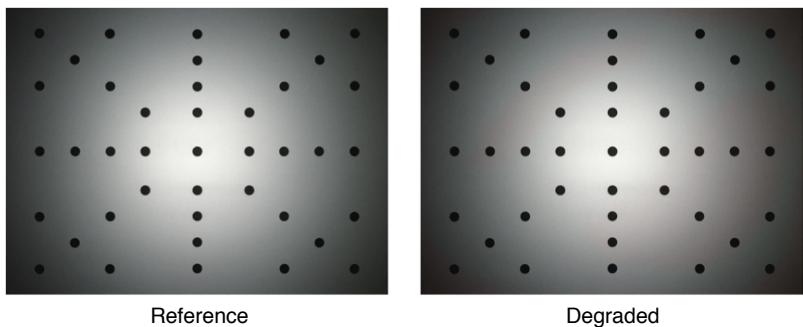
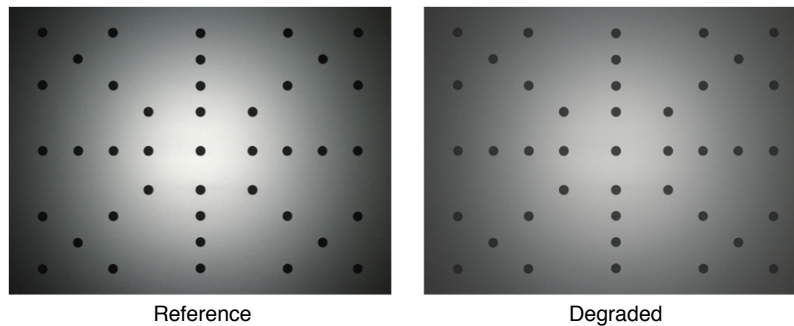

Figure 5-9 Sample image degradation by flash interference

5.8 Reliability

Cases for devices shall be tested to verify that they will withstand long-term use under typical use conditions, and that they do not impair or degrade the functionality of the device, damage it or its immediate surroundings, or adversely affect the user.

5.8.1 Device Insertion and Removal

The case shall hold the device securely while permitting its easy insertion and removal. The case and the enclosed device shall not be damaged by the repeated insertion and removal of the device from the case under conditions representative of long-term use in a variety of environments.

5.8.2 Colorfastness

Any dyes, inks, or coatings in or on the case shall not bleed color onto either the device or its user, particularly while the case is in contact with common substances, such as water or sunscreen.

5.9 Environmental

Accessories shall comply with applicable environmental regulations in the regions in which such accessories are to be sold, and any applicable substance or material restrictions, including applicable restrictions on the following substances:

- Organic tin compounds, PFOS, PFOA, phthalates, azo dyes, polybrominated biphenyls (PBBs) and PAHs, per requirements of the EU REACH regulation EC 1907/2006.
- Nickel leach rate on surfaces in prolonged skin contact, per requirements of the EU REACH regulation EC 1907/2006.
- Cadmium, lead, hexavalent chromium, and nickel, per requirements of EU Directive 2009/48/EC.
- Natural rubber latex, per requirements of EU Directive EC 93/42/EEC.

5. Cases

5.10 Test Procedures

- Dimethylfumarate (DMFu), per requirements of EU Regulation 412/2012.
- pH and Formaldehyde, per requirements of China GB 18401 for textiles and China GB 20400 for leather.
- Endangered species of flora and fauna in products or packaging (US Lacey Act).
- Polybrominated diphenyl ethers (PBDE).
- Compliance with California proposition 65, as applicable.

5.10 Test Procedures

5.10.1 Device Models

Case testing procedures vary depending on the device they enclose.

5.10.1.1 iPhone 12 Pro Max

Table 5-1 iPhone 12 Pro Max Case Testing Matrix

| Test | Using | Notes |
|--|-------------------|-------|
| Product Design (page 43) | iPhone 12 Pro Max | |
| Taptic Engine (page 45) | iPhone 12 Pro Max | |
| Acoustics (page 47) | iPhone 12 Pro Max | |

5.10.1.2 iPhone 12 Pro

Table 5-2 iPhone 12 Pro Case Testing Matrix

| Test | Using | Notes |
|--|---------------|-------|
| Product Design (page 43) | iPhone 12 Pro | |
| Taptic Engine (page 45) | iPhone 12 Pro | |
| Acoustics (page 47) | iPhone 12 Pro | |

5.10.1.3 iPhone 12

Table 5-3 iPhone 12 Case Testing Matrix

| Test | Using | Notes |
|--|-----------|-------|
| Product Design (page 43) | iPhone 12 | |
| Taptic Engine (page 45) | iPhone 12 | |
| Acoustics (page 47) | iPhone 12 | |

5.10.1.4 iPhone 12 mini

Table 5-4 iPhone 12 mini Case Testing Matrix

| Test | Using | Notes |
|--|----------------|-------|
| Product Design (page 43) | iPhone 12 mini | |
| Taptic Engine (page 45) | iPhone 12 mini | |
| Acoustics (page 47) | iPhone 12 mini | |

5.10.1.5 iPhone 11 Pro Max

Table 5-5 iPhone 11 Pro Max Case Testing Matrix

| Test | Using | Notes |
|--|-------------------|-------|
| Product Design (page 43) | iPhone 11 Pro Max | |
| Taptic Engine (page 45) | iPhone 11 Pro Max | |
| Acoustics (page 47) | iPhone 11 Pro Max | |

5.10.1.6 iPhone 11 Pro

Table 5-6 iPhone 11 Pro Case Testing Matrix

| Test | Using | Notes |
|--|---------------|-------|
| Product Design (page 43) | iPhone 11 Pro | |
| Taptic Engine (page 45) | iPhone 11 Pro | |
| Acoustics (page 47) | iPhone 11 Pro | |

5.10.1.7 iPhone 11

Table 5-7 iPhone 11 Case Testing Matrix

| Test | Using | Notes |
|--|-----------|-------|
| Product Design (page 43) | iPhone 11 | |
| Taptic Engine (page 45) | iPhone 11 | |
| Acoustics (page 47) | iPhone 11 | |

5.10.1.8 iPhone XS Max

Table 5-8 iPhone XS Max Case Testing Matrix

| Test | Using | Notes |
|--|---------------|-------|
| Product Design (page 43) | iPhone XS Max | |
| Taptic Engine (page 45) | iPhone XS Max | |
| Acoustics (page 47) | iPhone XS Max | |

5.10.1.9 iPhone XS

Table 5-9 iPhone XS Case Testing Matrix

| Test | Using | Notes |
|--|-----------|-------|
| Product Design (page 43) | iPhone XS | |
| Taptic Engine (page 45) | iPhone XS | |
| Acoustics (page 47) | iPhone XS | |

5.10.1.10 iPhone XR

Table 5-10 iPhone XR Case Testing Matrix

| Test | Using | Notes |
|--|-----------|-------|
| Product Design (page 43) | iPhone XR | |
| Taptic Engine (page 45) | iPhone XR | |
| Acoustics (page 47) | iPhone XR | |

5.10.1.11 iPhone X

Table 5-11 iPhone X Case Testing Matrix

| Test | Using | Notes |
|--|----------|-------|
| Product Design (page 43) | iPhone X | |
| Taptic Engine (page 45) | iPhone X | |
| Acoustics (page 47) | iPhone X | |

5.10.1.12 iPhone 8 Plus/iPhone 7 Plus

Table 5-12 iPhone 8 Plus/iPhone 7 Plus Case Testing Matrix

| Test | Using | Notes |
|--|---------------------------------|-------|
| Product Design (page 43) | iPhone 8 Plus and iPhone 7 Plus | |
| Taptic Engine (page 45) | iPhone 8 Plus and iPhone 7 Plus | |
| Home Button / Touch ID Sensor Overlays (page 46) | iPhone 8 Plus and iPhone 7 Plus | |
| Acoustics (page 47) | iPhone 8 Plus and iPhone 7 Plus | |

It is not possible for a case to claim compatibility with only the iPhone 8 Plus or only the iPhone 7 Plus.

5.10.1.13 iPhone SE (2nd generation)/iPhone 8/iPhone 7

Table 5-13 iPhone SE (2nd generation)/iPhone 8/iPhone 7 Case Testing Matrix

| Test | Using | Notes |
|--|--|-------|
| Product Design (page 43) | iPhone SE (2nd generation), iPhone 8, and iPhone 7 | |

5. Cases

5.10 Test Procedures

| Test | Using | Notes |
|--|--|-------|
| Taptic Engine (page 45) | iPhone SE (2nd generation), iPhone 8, and iPhone 7 | |
| Home Button / Touch ID Sensor Overlays (page 46) | iPhone SE (2nd generation), iPhone 8, and iPhone 7 | |
| Acoustics (page 47) | iPhone SE (2nd generation), iPhone 8, and iPhone 7 | |

It is not possible for a case to claim compatibility with only the iPhone SE (2nd generation), only the iPhone 8, or only the iPhone 7.

5.10.1.14 iPhone 6s Plus/iPhone 6 Plus

Table 5-14 iPhone 6s Plus/iPhone 6 Plus Case Testing Matrix

| Test | Using | Notes |
|--|----------------------------------|-------|
| Product Design (page 43) | iPhone 6s Plus and iPhone 6 Plus | |
| Taptic Engine (page 45) | iPhone 6s Plus | |

It is not possible for a case to claim compatibility with only the iPhone 6s Plus or only the iPhone 6 Plus.

5.10.1.15 iPhone 6s/iPhone 6

Table 5-15 iPhone 6s/iPhone 6 Case Testing Matrix

| Test | Using | Notes |
|--|------------------------|-------|
| Product Design (page 43) | iPhone 6s and iPhone 6 | |
| Taptic Engine (page 45) | iPhone 6s | |

It is not possible for a case to claim compatibility with only the iPhone 6s or only the iPhone 6.

5.10.1.16 iPhone 5/iPhone 5s/iPhone SE

Table 5-16 iPhone 5/iPhone 5s/iPhone SE Case Testing Matrix

| Test | Using | Notes |
|--|-----------|-------|
| Product Design (page 43) | iPhone SE | |

It is not possible for a case to claim compatibility with only the iPhone 5 or only the iPhone 5s or only the iPhone SE.

5.10.1.17 iPhone 5c

Table 5-17 iPhone 5c Case Testing Matrix

| Test | Using | Notes |
|--|-----------|-------|
| Product Design (page 43) | iPhone 5c | |

5.10.1.18 iPad Air (4th generation)

Table 5-18 iPad Air (4th generation) Case Testing Matrix

| Test | Using | Notes |
|--|---------------------------|-------|
| Product Design (page 43) | iPad Air (4th generation) | |

5.10.1.19 iPad Pro (12.9-inch) 4th Generation

Table 5-19 iPad Pro (12.9-inch) 4th Generation Case Testing Matrix

| Test | Using | Notes |
|--|-------------------------------------|-------|
| Product Design (page 43) | iPad Pro (12.9-inch) 4th Generation | |

5.10.1.20 iPad Pro (11-inch) 2nd Generation

Table 5-20 iPad Pro (11-inch) 2nd Generation Case Testing Matrix

| Test | Using | Notes |
|--|-----------------------------------|-------|
| Product Design (page 43) | iPad Pro (11-inch) 2nd Generation | |

5.10.1.21 iPad (7th generation)/iPad (8th generation)

Table 5-21 iPad (7th generation)/iPad (8th generation) Case Testing Matrix

| Test | Using | Notes |
|--|---|-------|
| Product Design (page 43) | iPad (7th generation) and iPad (8th generation) | |

It is not possible for a case to claim compatibility with only the iPad (7th generation) or only the iPad (8th generation).

5.10.1.22 iPad Air (3rd generation)

Table 5-22 iPad Air (3rd generation) Case Testing Matrix

| Test | Using | Notes |
|--|---------------------------|-------|
| Product Design (page 43) | iPad Air (3rd generation) | |

5.10.1.23 iPad mini (5th generation)

Table 5-23 iPad mini (5th generation) Case Testing Matrix

| Test | Using | Notes |
|--|----------------------------|-------|
| Product Design (page 43) | iPad mini (5th generation) | |

5.10.1.24 iPad Pro (12.9-inch) 3rd Generation

Table 5-24 iPad Pro (12.9-inch) 3rd Generation Case Testing Matrix

| Test | Using | Notes |
|--|-------------------------------------|-------|
| Product Design (page 43) | iPad Pro (12.9-inch) 3rd Generation | |

5.10.1.25 iPad Pro (11-inch)

Table 5-25 iPad Pro (11-inch) Case Testing Matrix

| Test | Using | Notes |
|--|--------------------|-------|
| Product Design (page 43) | iPad Pro (11-inch) | |

5.10.1.26 iPad Pro (10.5-inch)

Table 5-26 iPad Pro (10.5-inch) Case Testing Matrix

| Test | Using | Notes |
|--|----------------------|-------|
| Product Design (page 43) | iPad Pro (10.5-inch) | |

5.10.1.27 iPad Pro (12.9-inch) 2nd Generation

Table 5-27 iPad Pro (12.9-inch) 2nd Generation Case Testing Matrix

| Test | Using | Notes |
|--|-------------------------------------|-------|
| Product Design (page 43) | iPad Pro (12.9-inch) 2nd Generation | |

5.10.1.28 iPad (5th and 6th generation)

Table 5-28 iPad (5th and 6th generation) Case Testing Matrix

| Test | Using | Notes |
|--|--|-------|
| Product Design (page 43) | iPad (5th generation) or iPad (6th generation) | |

5. Cases

5.10 Test Procedures

5.10.1.29 iPad Pro (9.7-inch)

Table 5-29 iPad Pro (9.7-inch) Case Testing Matrix

| Test | Using | Notes |
|--|---------------------|-------|
| Product Design (page 43) | iPad Pro (9.7-inch) | |

5.10.1.30 iPad Pro (12.9-inch) 1st Generation

Table 5-30 iPad Pro (12.9-inch) 1st Generation Case Testing Matrix

| Test | Using | Notes |
|--|-------------------------------------|-------|
| Product Design (page 43) | iPad Pro (12.9-inch) 1st Generation | |

5.10.1.31 iPad mini 4

Table 5-31 iPad mini 4 Case Testing Matrix

| Test | Using | Notes |
|--|-------------|-------|
| Product Design (page 43) | iPad mini 4 | |

5.10.1.32 iPad mini/iPad mini 2/iPad mini 3

Table 5-32 iPad mini/iPad mini 2/iPad mini 3 Case Testing Matrix

| Test | Using | Notes |
|--|-------------|-------|
| Product Design (page 43) | iPad mini 3 | |

It is not possible for a case to claim compatibility with only the iPad mini or only the iPad mini 2 or only the iPad mini 3.

5.10.1.33 iPad Air 2

Table 5-33 iPad Air 2 Case Testing Matrix

| Test | Using | Notes |
|--|------------|-------|
| Product Design (page 43) | iPad Air 2 | |

5.10.1.34 iPad Air

Table 5-34 iPad Air Case Testing Matrix

| Test | Using | Notes |
|--|----------|-------|
| Product Design (page 43) | iPad Air | |

5.10.1.35 iPad (4th generation)

Table 5-35 iPad (4th generation) Case Testing Matrix

| Test | Using | Notes |
|--|-----------------------|-------|
| Product Design (page 43) | iPad (4th generation) | |

5.10.1.36 iPod touch (5th generation)/iPod touch (6th generation)/iPod touch (7th generation)

Table 5-36 iPod touch (5th generation)/iPod touch (6th generation)/iPod touch (7th generation) Case Testing Matrix

| Test | Using | Notes |
|--|-----------------------------|-------|
| Product Design (page 43) | iPod touch (7th generation) | |

It is not possible for a case to claim compatibility with only the iPod touch (5th generation), iPod touch (6th generation) or the iPod touch (7th generation).

5.10.2 Product Design

5.10.2.1 Equipment

- Device
- Apple Lightning Digital AV Adapter
- Vernier calipers
- 0.85 mm plastic feeler gauge
- EarPods with 3.5 mm Headphone Plug

5.10.2.2 Procedure

1. Insert the device into the case.
2. Verify that the device completely fits inside the case.
3. Verify the device is not loose.
4. Verify that all buttons are accessible.
5. Inspect for button feel. Verify that all buttons are not too hard to press or take a lot of effort to press.
6. If the device has an Apple Lightning connector:
 - a. Insert the Apple Lightning Digital AV Adapter into the Lightning receptacle and verify that it fits.
 - b. Using vernier calipers, measure the Lightning connector opening on the case. Verify that the opening is measured to be at least 12.05 mm by 6.30 mm.
7. If the device has a 3.5 mm headset jack:
 - a. Insert EarPods with 3.5 mm Headphone Plug into the headset jack of the device and verify it fits.

- b. Using vernier calipers, measure the headset jack opening on the case. Verify that the opening is measured to be at least 6 mm in diameter and no more than 14 mm deep.
- 8. If the device has a Touch ID sensor, use vernier calipers to verify that the case is at least 2 mm away from the Touch ID sensor.
- 9. Verify that the case is always proud of the feeler gauge when the gauge is placed at each corner of the device. See [Figure 5-10](#) (page 44).

Figure 5-10 Device proudness test

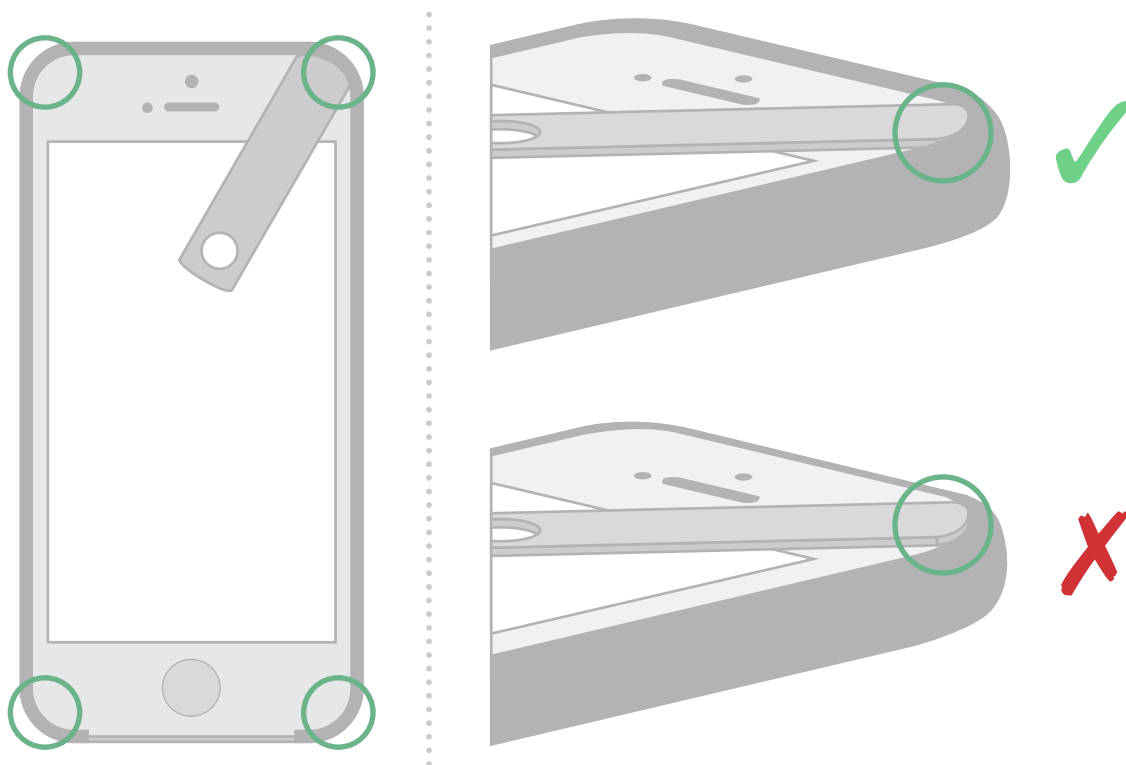

- 10. Set the device flat on its face (screen facing down).
- 11. Roll the device towards any side that is not enclosed by the case until the gap between the device's exposed glass and flat surface is smallest.

12. Verify that the feeler gauge fits into the gap between the device's exposed glass and flat surface.

Figure 5-11 Device gap test

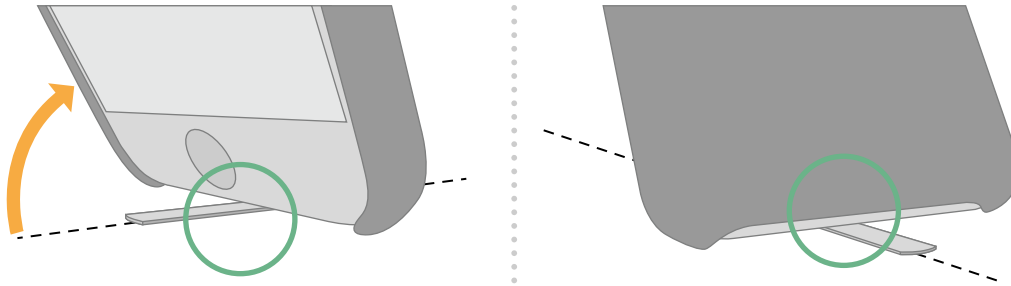

13. If the case has an overlay, verify that there are no air gaps introduced between it and the touchscreen.

5.10.3 Taptic Engine

5.10.3.1 Equipment

- Two devices A and B, same model
- Table

5.10.3.2 Procedure

1. Attach the case to device B.
2. Place device A on top of the table.
3. Place device B on top of the table next to device A.
4. Compare the Taptic Engine feedback between device A and device B for each of the following tasks:
 - a. Go to: *Settings > Sound & Haptics*, set *Vibrate on Silent* to the on position.
 - b. Toggle the Ring/Silent switch.
 - c. Connect a charger to both devices.
 - d. Go to: *Settings > Notifications > Phone > Sounds*, select *Reflection (Default)*.
 - e. Go to: *Settings > Notifications > Messages > Sounds*, select *Note (Default)*.
 - f. Go to the Home screen.
 - g. Trigger a Quick Actions menu by applying pressure to the Settings app. Continue applying pressure.
 - h. Slide your finger across the Quick Actions menu and release when Wi-Fi is selected.
 - i. Go to the Home screen.
 - j. Apply pressure to the Home app.
 - k. Go to: Clock app and select *Timer* on the bottom right.
 - l. Scroll through the hours and minutes.

5. Cases

5.10 Test Procedures

5. If the device has a Home button:
 - a. Go to: *Settings > General > Home Button*, tap option 2.
 - b. Press the Home button.
6. Repeat the above tasks while holding device A in the left hand and device B in the right hand.

5.10.3.3 Pass/Fail Criteria

The case does not cause substantial change in the feel of the device's Taptic Engine.

5.10.4 Home Button / Touch ID Sensor Overlays

This test procedure is applicable to all iPhone SE (2nd generation), iPhone 8 Plus, iPhone 8, iPhone 7 Plus or iPhone 7 accessories that overlay the Home button or the Touch ID sensor.

5.10.4.1 Equipment

- Nitrile gloves (e.g. Ansell TNT Blue)
- Ethyl alcohol hand sanitizer (e.g. Purell)
- Scissors

5.10.4.2 Procedure

1. Cut off a square of material from the nitrile glove's wrist portion.
2. Install the accessory onto the device.
3. Press the sleep/wake or side button to place the device into a sleep state (display off).
4. Place the square of nitrile glove material over the device's Home button / Touch ID sensor with the glove's outer side facing away from the device.
5. Apply a small amount of hand sanitizer (approximately dime-sized) to the nitrile over the Home button / Touch ID sensor.
6. Repeat the following steps 10 times:
 - a. Press the Home button / Touch ID sensor with a thumb.
 - b. Verify that the device wakes (display on).
 - c. Press the sleep/wake or side button to place the device into a sleep state (display off).
7. Repeat the following steps 10 times:
 - a. Press the Home button / Touch ID sensor with an index finger.
 - b. Verify that the device wakes (display on).
 - c. Press the sleep/wake or side button to place the device into a sleep state (display off).

5.10.4.3 Pass/Fail Criteria

Verify the device wakes every time the Home button / Touch ID sensor is pressed.

5.10.5 Acoustics

The following test procedures apply to devices with a built in speaker and/or microphone.

5.10.5.1 Speakerphone Call

This procedure evaluates the impact of a case on the speakerphone performance of a device.

5.10.5.1.1 Equipment and Test Setup

This procedure requires two operators in separate quiet rooms.

Room A:

- Operator A
- The device (with cellular service) used to evaluate the case
 - The device should have at least two out of five bars of cellular reception within the room.

Room B:

- Operator B
- Landline speakerphone
- Digital audio recorder (e.g., a device with the Voice Memo app)

5.10.5.1.2 Pass/Fail Criteria

There are two categories of failure for this procedure:

- Echo: If Operator B hears their own voice from the landline.
- Double Talk: If Operator B hears Operator A inconsistently.

The pass/fail threshold for these two categories should be established by performing the test procedure using:

- The device (without the case) as a reference.

There should be no perceivable difference between the reference and the test conducted with the case on the device.

5.10.5.1.3 Procedure

1. Operator A: Use the device (without a case) in Room A to call the landline phone in Room B.
2. Operator A: Place the device in speakerphone mode.
3. Operator B: Answer the call with the landline phone in Room B.
4. Operator B: Place the landline phone in speakerphone mode.
5. Operator A and B: Simultaneously recite the following phrases to evaluate the call quality:

5. Cases

5.10 Test Procedures

- a. The birch canoe slid on the smooth planks.
 - b. Glue the sheet to the dark blue background.
 - c. It's easy to tell the depth of a well.
 - d. These days a chicken leg is a rare dish.
 - e. Rice is often served in round bowls.
 - f. The juice of lemons makes fine punch.
 - g. The box was thrown beside the parked truck.
 - h. The hogs were fed chopped corn and garbage.
 - i. Four hours of steady work faced us.
 - j. Large size in stockings is hard to sell.
6. Operator B: Evaluate the call. Ensure that the call is clear when there is no case on the device.
 7. Operator A: Place the case on the device.
 8. Operator B: Start audio recording using a digital audio recorder.
 9. Operator A: State the test date and identify the manufacturer name, product name, and a unique identifier (UID) for case (production run name, design version, etc.).
 10. Operator A and B: Simultaneously recite the same phrases as above.
 11. Operator B: Stop audio recording.
 12. Operator B: Evaluate the recording against the [Pass/Fail Criteria](#) (page 47).

Note: The phrases used for this test procedure are from "IEEE Recommended Practice for Speech Quality Measurements," in *IEEE Transactions on Audio and Electroacoustics*, vol. 17, no. 3, pp. 225-246, September 1969.

6. Covers

This chapter is applicable to accessories that cover device displays.

6.1 Magnetic Interference

Accessory covers shall not interfere with the device's:

- Magnetic compass.
- Rear camera autofocus.
- Rear camera optical image stabilization (OIS), if present.

See [Magnetic Interference](#) (page 19) for additional details.

6.2 Smart Covers

Dimensional drawings indicating magnet and Hall effect sensor locations are available for the following devices:

- [iPad Air \(4th generation\) 3 of 5](#) (page 190)
- [iPad Pro \(12.9-inch\) 4th Generation 3 of 5](#) (page 195)
- [iPad Pro \(11-inch\) 2nd Generation 3 of 5](#) (page 200)
- [iPad \(7th generation\) & iPad \(8th generation\) 2 of 3](#) (page 204)
- [iPad Air \(3rd generation\) with Wi-Fi 2 of 3](#) (page 207)
- [iPad Air \(3rd generation\) with Wi-Fi + Cellular 2 of 3](#) (page 210)
- [iPad mini \(5th generation\) with Wi-Fi 2 of 3](#) (page 213)
- [iPad mini \(5th generation\) with Wi-Fi + Cellular 2 of 3](#) (page 216)
- [iPad Pro \(12.9-inch\) 3rd Generation 2 of 3](#) (page 219)
- [iPad Pro \(11-inch\) 2 of 3](#) (page 222)
- [iPad Pro \(12.9-inch\) 2nd Generation Magnet/Hall Effect Sensors 1 of 2](#) (page 226)
- [iPad Pro \(12.9-inch\) 2nd Generation Magnet/Hall Effect Sensors 2 of 2](#) (page 227)
- [iPad Pro \(10.5-inch\) Magnet/Hall Effect Sensors 1 of 2](#) (page 230)
- [iPad Pro \(10.5-inch\) Magnet/Hall Effect Sensors 2 of 2](#) (page 231)
- [iPad \(5th and 6th generation\) Magnet/Hall Effect Sensors 1 of 2](#) (page 233)
- [iPad \(5th and 6th generation\) Magnet/Hall Effect Sensors 2 of 2](#) (page 234)

6. Covers

6.2 Smart Covers

- [iPad Pro \(9.7-inch\) Magnet/Hall Effect Sensors 1 of 2 \(page 237\)](#)
- [iPad Pro \(9.7-inch\) Magnet/Hall Effect Sensors 2 of 2 \(page 238\)](#)
- [iPad Pro \(12.9-inch\) 1st Generation Magnet/Hall Effect Sensors 1 of 2 \(page 241\)](#)
- [iPad Pro \(12.9-inch\) 1st Generation Magnet/Hall Effect Sensors 2 of 2 \(page 242\)](#)
- [iPad mini 4 Magnet/Hall Effect Sensors \(page 245\)](#)

7. Screen Overlays

The touch interface in a device senses the presence of one or more fingers on its surface. Any material between the surface and the user's hand, even a very thin sheet of plastic, may affect the performance of the touch interface.

7.1 Product Design

The screen overlay shall not degrade the performance of Multi-Touch or Apple Pencil.

The screen overlay thickness should not exceed 0.1 mm for devices supporting Apple Pencil.

The screen overlay thickness should not exceed 0.3 mm for all other devices.

Additionally, screen overlays shall not:

- Introduce air gaps between the touchscreen and overlay.
- Be electrically conductive.

7.2 Edge Swipe and Edge Press Gestures

See [Edge Swipe Gestures](#) (page 27) and [Edge Press Gestures](#) (page 27).

8. Camera Attachments

This chapter is applicable to accessories that intentionally alter the images captured by device cameras.

8.1 Magnetic Interference

Accessory camera attachments shall not interfere with the device's:

- Magnetic compass.
- Rear camera autofocus.
- Rear camera optical image stabilization (OIS), if present.

See [Magnetic Interference](#) (page 19) for additional details.

9. Adapters

An adapter accessory is a dongle or a [Captured Cable](#) (page 16) that enables connections between physically incompatible devices and accessories.

Unless otherwise specified, accessories may integrate one or more adapter components as well as other accessory features to create more advanced multi-port adapters. For example, a Lightning or USB-C adapter may support audio, power, external storage, media controls, app communication, and more.

See the [Accessory Interface Specification](#) (page 16) for more information.

9.1 Headset Adapters (Lightning to 3.5 mm)

Lightning to 3.5 mm headset adapters are accessories that enable 3.5 mm audio connections.

See the [Accessory Interface Specification](#) (page 16) for more information.

9.2 USB-A/USB-C to Lightning Headset Adapters

USB-A to Lightning or USB-C to Lightning headset adapters are accessories that integrate a Lightning Receptacle (C37) to support Lightning headsets, speakers, and microphones.

See the [Accessory Interface Specification](#) (page 16) for more information.

9.3 Ethernet Adapters (Lightning to RJ45)

A Lightning to Ethernet adapter is an accessory that enables a device to access a wired network. The Apple USB Ethernet Adapter is an example of a similar accessory for a Mac.

See the [Accessory Interface Specification](#) (page 16) for more information.

9.4 Lightning to USB Micro-B Adapters

Figure 9-1 Lightning to USB Micro-B Adapter

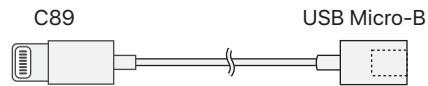

Lightning to USB Micro-B adapters are Lightning dongle accessories that function exactly like the Apple Lightning to USB Micro-B Adapter and shall consist of:

- Lightning connector.
- USB Micro-B receptacle.

See the [Accessory Interface Specification](#) (page 16) for more information.

10. AC Power Adapters

AC power adapters convert AC "mains" power to DC for the purpose of providing power to a device. They may provide power via one or more of the following:

- [USB-C Receptacle](#) (page 153) combined with a USB-C to Lightning cable.
- [USB-A Receptacle](#) (page 150) combined with a USB-A to Lightning cable.
- [Qi Wireless Power](#) (page 22).

10.1 Converter Switching Frequencies

Device touchscreen or audio functionality may be degraded if converter switching frequencies do not meet the following requirements:

- Under loads greater than 5 mA, converter switching frequencies shall be above 22 kHz.
- Under loads greater than 20 mA, converter switching frequencies:
 - Shall be above 60 kHz.
 - Should be above 450 kHz.

10.2 YCAP AC Capacitor

AC power adapters should include a YCAP AC capacitor (up to 1000 pF) between the primary and secondary sections of the adapter's transformer to reduce common-mode noise at switching frequencies. These frequencies or their harmonics can interfere with device touchscreen sensors.

10.3 Impedance Stability

AC power adapter series impedance should not change abruptly. Sudden changes in impedance may cause touchscreen sensor output oscillations.

Bridge diodes used in full-wave bridge rectifiers can be a major source of abrupt changes in the series impedance. If the bridge diodes have large inherent reverse capacitance (greater than 100 pF), then the net impedance change due to diode switching may be acceptably small. However, diode reverse capacitance may decrease in more compact IC designs due to decreased chip area.

Impedance of bridge diodes with unacceptably low reverse capacitance can be stabilized using the example circuit shown in [Figure 10-1](#) (page 56) and [Table 10-1](#) (page 56). In this example, capacitors C1, C2, C3, and C4 have been placed in parallel with diodes D1, D2, D3, and D4 to stabilize the bridge impedance. Their values are larger than the inherent reverse capacitances of the diodes.

Resistors R1, R2, R3, and R4 are optional; if included, they can block noise at very high frequencies, which can help with EMI compatibility. The recommended values of R1, R2, R3, and R4 in [Table 10-1](#) (page 56) were chosen to have trivial levels of impedance relative to the impedances of C1, C2, C3, and C4 at power line frequencies.

Figure 10-1 Typical AC power adapter diode bridge circuit

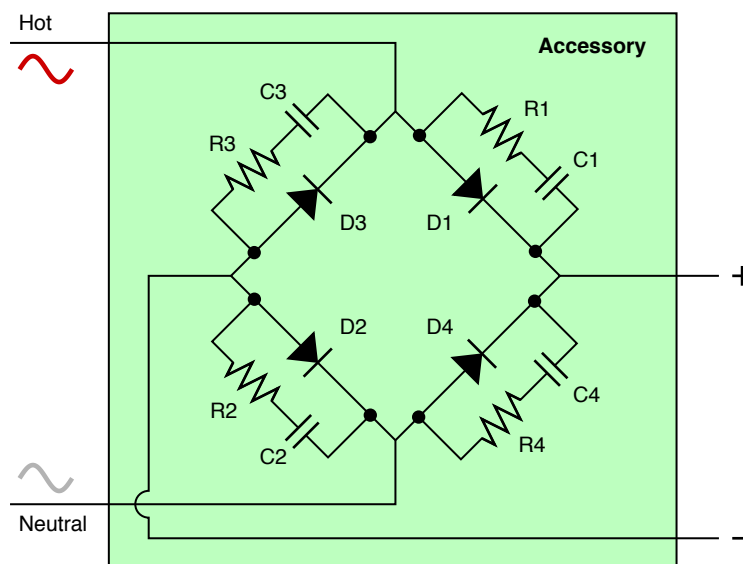

Table 10-1 Typical component values for an AC power adapter diode bridge circuit

| Component | Value |
|----------------|-------|
| C1, C2, C3, C4 | 47 pF |
| R1, R2, R3, R4 | 2 kΩ |

10.4 Fuse Protection

A fuse should be present at the input of the AC power adapter to protect it under any fault condition.

10.5 Short Circuit Response

The output of the AC power adapter should drop or fold back without any resulting damage if its output is shorted to the secondary common (less than 10 m Ω).

11. Battery Packs

A battery pack is an accessory that is designed to provide power to the device from an internal power supply.

The battery pack may provide power via one or more of the following:

- [USB-C Receptacle](#) (page 153) combined with a USB-C to Lightning cable.
- [USB-A Receptacle](#) (page 150) combined with a USB-A to Lightning cable.
- [Qi Wireless Power](#) (page 22).

12. Strobes

Strobe accessories replace a device's integrated flash when capturing a still image from either the front or rear-facing cameras. Photographers can use such accessories to control scene lighting for creative purposes.

Strobes are:

- Compatible with all iOS camera applications.
- Synchronized with the iPhone camera via the Lightning connector.

Figure12-1 Integrated flash [L] vs. integrated flash and accessory strobe [R] example



The following devices support strobe accessories:

- iPhone 12 Pro Max
- iPhone 12 Pro
- iPhone 12

- iPhone 12 mini
- iPhone SE (2nd generation)
- iPhone 11 Pro Max
- iPhone 11 Pro
- iPhone 11

This feature is supported on iOS 14.0 or later.

See the [Accessory Interface Specification](#) (page 16) for more information.

13. AirPods Accessories

Apple AirPods accessories such as charging case covers shall not interfere with their operation.

Relevant keep-out regions can be found in the device dimensional drawings, see:

- [AirPods Pro Wireless Charging Case](#) (page 278).
- [AirPods Pro](#) (page 280).
- [AirPods Wireless Charging Case](#) (page 279).
- [AirPods](#) (page 281).

14. Watch Bands

A well-designed band will securely attach to Apple Watch while not interfering with its operation. See [Device Dimensional Drawings](#) (page 157) for Apple Watch dimensional drawings with defined keep-out zones.

14.1 Requirements

Bands for Apple Watch shall integrate two lugs that mate with the [Figure 14-1](#) (page 64). Apple Watch uses a high precision interface profile, see <https://developer.apple.com/watch/bands/> for a sample 2D lug profile. Lugs should lock into the band mating slot with a 'lug latch' feature that prevents accidental removal of the band.

Exposed edges of bands and lugs shall pass UL 1439 tests for sharpness of edges on equipment and BS EN 71-1:2014, *Safety of Toys - Mechanical and physical properties*.

The lug latch shall never become jammed in the extended position.

Bands shall not integrate magnetic chargers.

Bands and lugs should:

- Pass a 72 hour salt mist test as specified in ASTM B117 with no visible corrosion.
- Resist a 5-20 kgf lateral slide-out force when installed in Apple Watch.
- Resist a 20 kgf or greater pull force as specified in ISO-6245:1996, *Specifications for Diver's Watches*, section 7.3.
- Detach easily from Apple Watch when the band release buttons are pressed.
- Take into account the weight of Apple Watch.

Bands shall not prevent the user's skin from maintaining direct contact with the Apple Watch heart sensors and back of Apple Watch, and shall incorporate sufficient margin to compensate for shifting or dimensional changes of the band material. Failure to do so may interfere with Apple Watch wrist detect and Apple Pay features. Bands should:

- Have length sizing adjustment pitch of less than 7 mm (center to center).
- Provide sufficient adjustability for the user to achieve a snug, yet comfortable, fit that prevents movement of Apple Watch relative to skin.

14. Watch Bands

14.1 Requirements

Bands intended for use during exercise should maintain a snug fit through a full range of motion to maintain compatibility with Apple Watch heart sensors.

Apple recommends the following materials for lug bodies:

- 75 Shore A silicone.
- 50-55% glass-filled nylon.
- 240-270HV 316L / EN 1.4435 stainless steel.

Apple recommends the following materials for lug latches:

- 50-55% glass-filled nylon.
- 240-270HV 316L / EN 1.4435 stainless steel.

Bands for Apple Watch shall comply with applicable environmental regulations in the regions in which such bands are to be sold, and any applicable substance or material restrictions, including applicable restrictions on the following substances:

- Organic tin compounds, PFOS, PFOA, phthalates, azo dyes, polybrominated biphenyls (PBBs) and PAHs, per requirements of the EU REACH regulation EC 1907/2006.
- Nickel leach rate on surfaces in prolonged skin contact, per requirements of the EU REACH regulation EC 1907/2006.
- Cadmium, lead, hexavalent chromium, and nickel, per requirements of EU Directive 2009/48/EC.
- Natural rubber latex, per requirements of EU Directive EC 93/42/EEC.
- Dimethylfumarate (DMFu), per requirements of EU Regulation 412/2012.
- pH and Formaldehyde, per requirements of China GB 18401 for textiles and China GB 20400 for leather.
- Endangered species of flora and fauna in products or packaging (US Lacey Act).
- Polybrominated diphenyl ethers (PBDE).

Figure 14-1 Apple Watch Band Interface

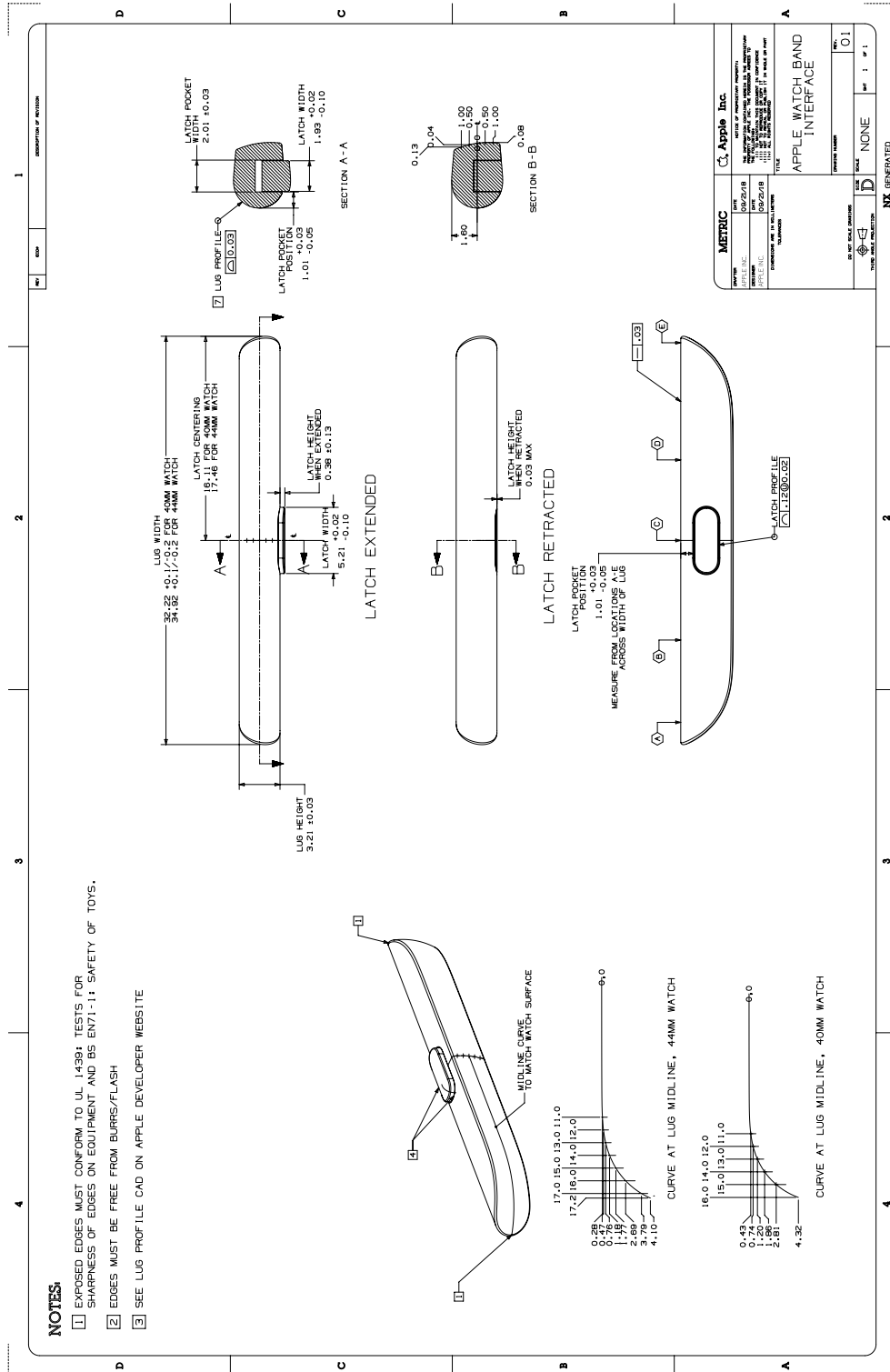

14.2 Example Apple Watch Lug Assembly

These assembly instructions are based on [Figure 14-3](#) (page 67) and an assembly fixture with a clamping mechanism.

Proper assembly of the lug is critical to ensure the band securely attaches to the Apple Watch. Improper assembly may result in damage to the Apple Watch and/or the band.

Screw threads should be secured with Loctite 435. Screws that have been previously installed/used should not be reused.

The assembly fixture should hold the lug assembly in place and a clamping mechanism should compress the lug during screw insertion.

Assemble the band and lug as follows, see [Figure 14-2](#) (page 66).

1. Lightly insert the long end of the female pin in the band until hard stop. Ensure there is no warping or damage in the band.
2. Lightly insert the long end of the male pin in the other side of the band until it interlocks with the female pin and both pins are seated together. Ensure there is no warping or damage in the band.
3. Align the holes on the bottom of the lug with the exposed ends of the female and male pins. Note lug latch top/bottom orientation relative to band. Latch shall be on the side of the band against the wrist.
4. Apply Loctite 435 to screw threads.
5. Install both screws using the following specification:
 - Torque: 1.1 kgf-cm \pm 10%
 - RPM: 120 \pm 10%
6. Inspect for screw proudness and cross-threading visually at 1200-1400 lux.
7. Ensure screw is just sub-flush to the lowest part of the counterbore and appears parallel to the long axis of the lug.
8. Ensure screw is flat and concentric with the counterbore, without damage.

14. Watch Bands

14.2 Example Apple Watch Lug Assembly

Figure 14-2 Apple Watch Lug Assembly Fixture

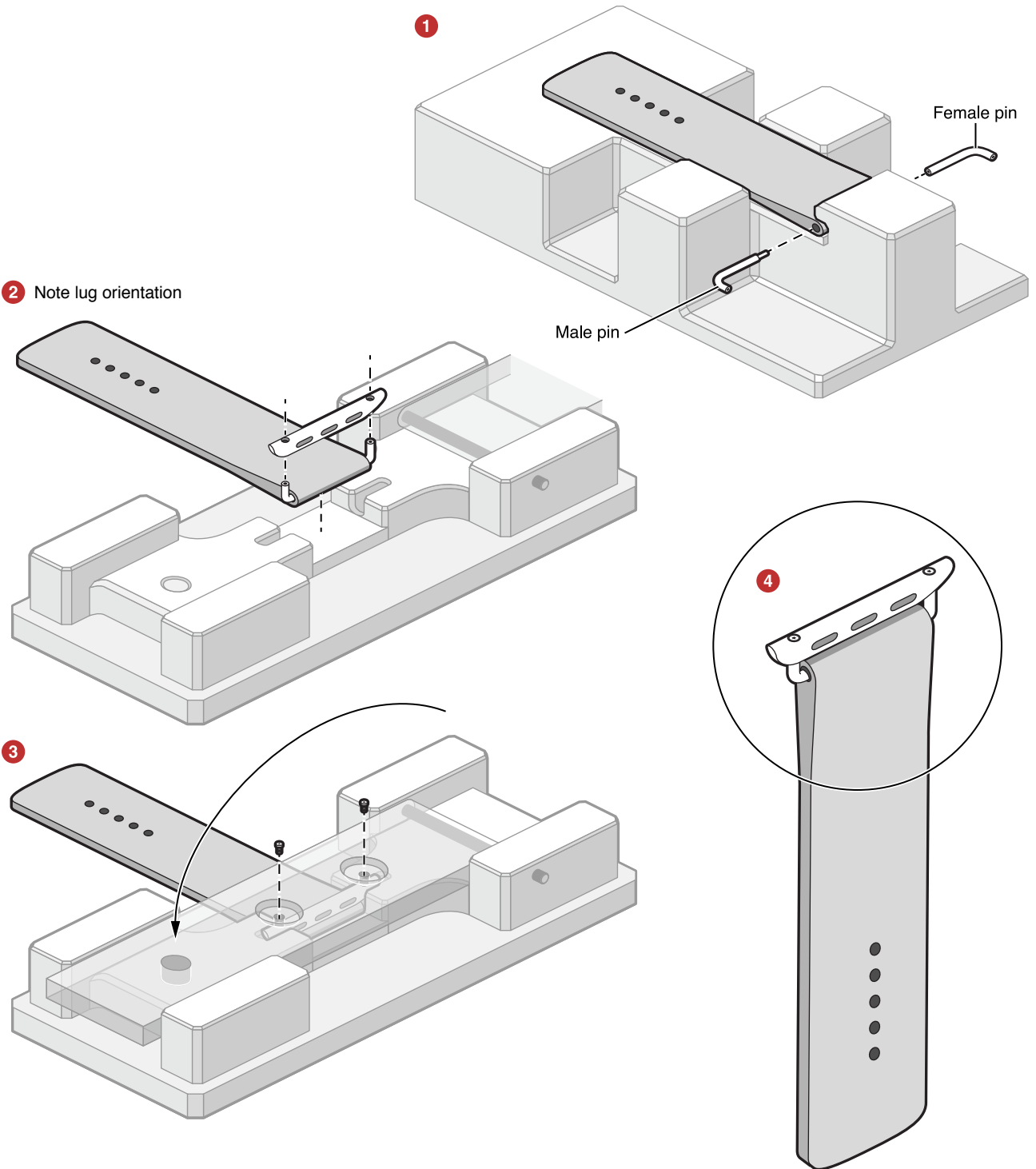

14. Watch Bands

14.2 Example Apple Watch Lug Assembly

Figure 14-3 Example Apple Watch Lug

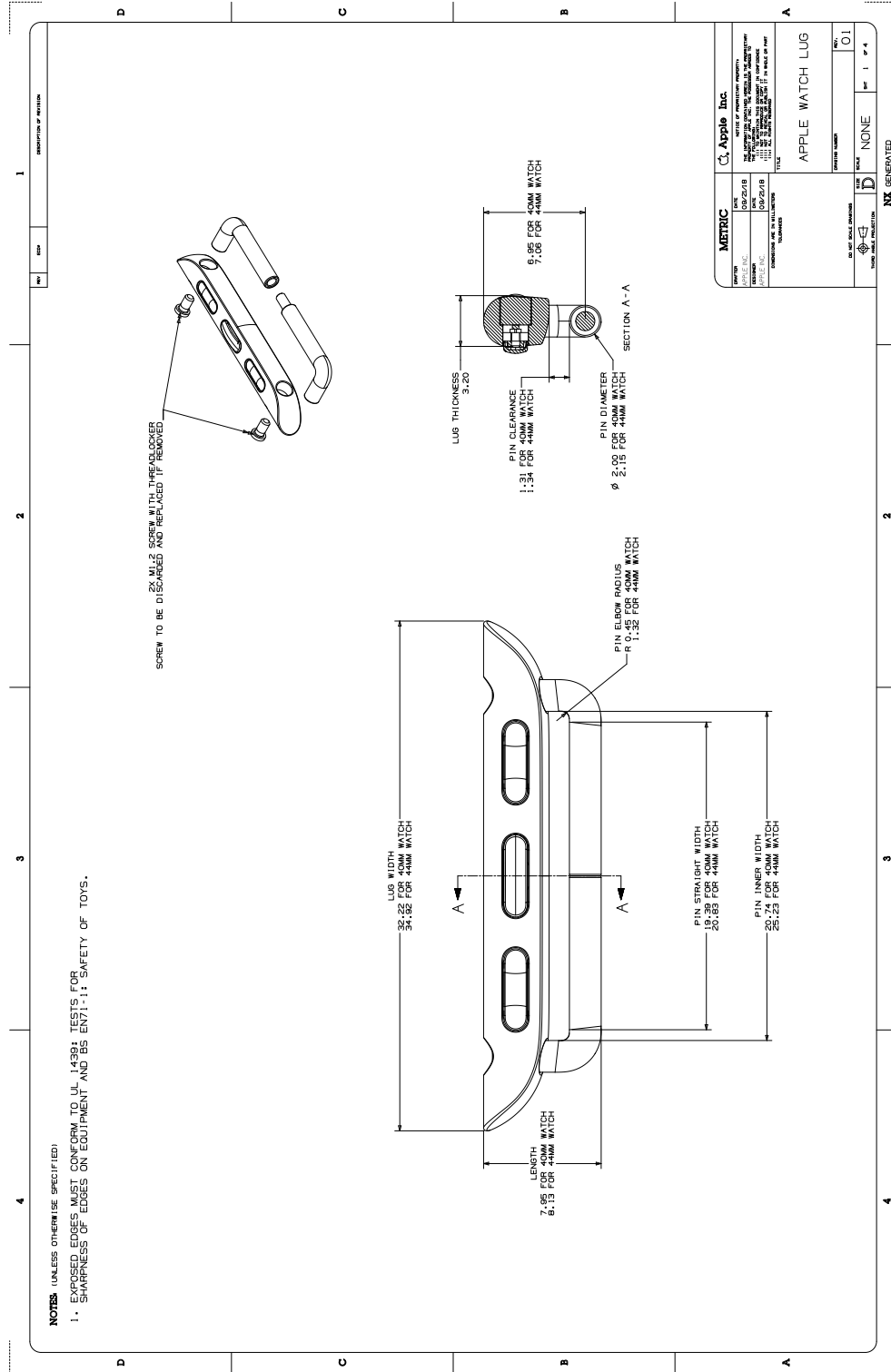

Features

15. Bluetooth Accessory Identification

This chapter describes Apple-specific Bluetooth commands that extend accessory capabilities beyond those supported by standard Bluetooth profiles.

To enable Apple-specific features, the accessory shall support [HFP Command AT+XAPL](#) (page 69), which provides accurate information about the accessory's supported features. The device will use the information sent by this command to enable and disable custom commands.

The accessory shall send the following AT+XAPL command after making a successful HFP Service Level Connection (SLC) to the device. The accessory should send an AT+XAPL command first, before sending any additional Apple-specific commands. See [Siri](#) (page 100) and [Bluetooth Headset Battery Level Indication](#) (page 75).

15.1 HFP Command AT+XAPL

Description: Enables custom AT commands from an accessory.

Initiator: Bluetooth accessory

Format: AT+XAPL=*vendorID-productID-version,features*

Parameters:

- *vendorID*: A string representation of the hex value of the vendor ID from the manufacturer, without the 0x prefix.
- *productID*: A string representation of the hex value of the product ID from the manufacturer, without the 0x prefix.
- *version*: The revision of the software.
- *features*: A base-10 representation of a bit field. Available features are:
 - Bit 0 = reserved
 - Bit 1 = The accessory supports battery reporting (reserved only for battery operated accessories).
 - Bit 2 = The accessory is docked or powered (reserved only for battery operated accessories).
 - Bit 3 = The accessory supports Siri status reporting.
 - Bit 4 = the accessory supports noise reduction (NR) status reporting.
 - All other values are reserved.

Example: AT+XAPL=ABCD-1234-0100,10 (Supports battery reporting and Siri status)

15. Bluetooth Accessory Identification

15.1 HFP Command AT+XAPL

Response: +XAPL=iPhone,*features*

16. Accessory Power (Lightning)

Accessories may draw a limited amount of power from a device and avoid the need to integrate a battery or connect to an external power source. This feature may eliminate the need for users to manage an additional accessory battery and permits the accessory to function as long as the device has power.

Accessories that temporarily connect to the device are good candidates for this feature. Additionally, the accessory should integrate the Lightning Receptacle (C37) and implement Lightning Receptacle (C37) Passthrough Power so users can charge the device from an external power source while the accessory is attached.

See the [Accessory Interface Specification](#) (page 16) for more information.

17. App Discovery

The App Discovery feature enables accessories to retrieve a list of installed apps on the device that can communicate with the accessory. See [App Launch](#) (page 73) to make use of the list.

See the [Accessory Interface Specification](#) (page 16) for more information.

18. App Launch

An accessory that supports the App Launch feature can request that a device launch an app on its behalf.

Figure 18-1 App Launch Alert



See the [Accessory Interface Specification](#) (page 16) for more information.

19. App Match

The App Match feature enables accessories that support the External Accessory Protocol feature to match with compatible apps on the App Store.

When connected for the first time, the device will ask the user if they would like to visit the App Store and view apps that work with the accessory. Subsequently, this action may be repeated by the user via *Settings > General > About > 'Accessory Name' > 'Find App for this Accessory'*.

Matched apps are listed in alphabetical order with one exception. If the accessory will work with apps from multiple development teams/companies, the accessory may provide a preferred Team ID that places apps from that development team at the top of the list.

Figure 19-1 App Match Alert

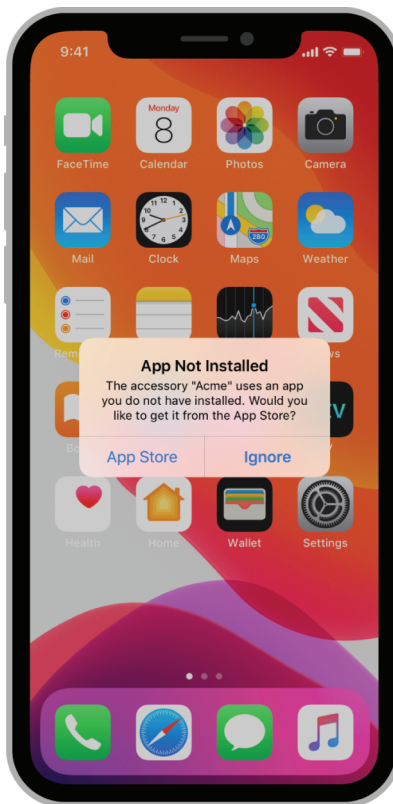

See the [Accessory Interface Specification](#) (page 16) for more information.

20. Bluetooth Headset Battery Level Indication

Any Hands-Free Bluetooth headset accessory can show its battery level to the user as an indicator icon in the device status bar. This feature is supported on all devices that support the Hands-Free Profile, including iPhone, iPod touch, and iPad.

Headset battery indication is implemented by two Apple-specific Bluetooth HFP AT commands, [HFP Command AT+XAPL](#) (page 69) and [HFP Command AT+IPHONEACCEV](#) (page 75)

20.1 HFP Command AT+IPHONEACCEV

Description: Reports a headset state change.

Initiator: Headset accessory

Format: AT+IPHONEACCEV=*Number of key/value pairs, key1, val1, key2, val2, . . .*

Parameters:

- *Number of key/value pairs:* The number of parameters coming next.
- *key:* the type of change being reported:
 - 1 = Battery Level
 - 2 = Dock State
- *val:* the value of the change:
 - Battery Level: string value between '0' and '9'
 - Dock State: 0 = undocked, 1 = docked

Example: AT+IPHONEACCEV=1, 1, 3

21. Device Power (Lightning)

The Device Power feature enables accessories to report their power characteristics and provide power to a device.

Apple strongly recommends providing power to the device whenever possible for the best user experience.

Accessories that provide power to a device shall connect to the device either through an integrated Lightning connector or a USB to Lightning cable. To incorporate an integrated Lightning connector, the accessory developer shall be a member of the Apple MFi licensing program. See <https://developer.apple.com/programs/mfi> for further information.

Accessories that provide power to a device shall either:

- Provide direct power, see [Direct Power Source](#) (page 76).
- Manage power from external sources, see [External Power Source](#) (page 76).

All accessories that do not have the potential for data communication with the device shall provide direct power to the device, see [Direct Power Source](#) (page 76).

21.1 Direct Power Source

Accessories that provide power directly shall provide power at all times unless a direct user action is taken to put the accessory into an 'off' state. Failure to provide power at all times may result in the accessory being unable to charge a device whose battery level is too low for the device to boot.

All accessory power source testing shall be performed with programmable loads, not devices. Device power draw varies with environmental factors.

21.2 External Power Source

Accessories that draw power from external power sources and provide all or a portion of that power to the device shall identify the power source's capability and report accordingly to the device.

Note: Accessories shall not manipulate a device into drawing more power from the external power source than the device would normally draw when directly connected to the external power source.

Accessories shall not manipulate a device into drawing less than the minimum power required by the accessory compatibility claims if it is available from the external source, see [Providing Power via USB Connectors](#) (page 77).

Accessories that draw power from external power sources may inform the device that power is not available or available at a reduced level (such as from an internal battery) when the user unplugs the accessory from the external power source (such as an AC power adapter or AC "mains" power outlet). Power to the device shall be restored (and the power providing capability change shall be communicated to the device) when the user re-connects the external power source.

See [AC Power Adapters](#) (page 55), [Integrated USB Receptacles](#) (page 18), and [User Supplied Cables and AC Power Adapters](#) (page 18) for additional requirements specific to external USB power supplies/cables.

21.3 Declaring Capability

If the accessory provides power via a:

- USB-A receptacle, then it shall use one of the following to declare its power providing capability:
 - [USB Power Capability Vendor Request](#) (page 117).
 - [USB D+/D- Resistor Networks](#) (page 118).
- USB-C receptacle, then:
 - It shall use one of the following to declare its power providing capability:
 - [USB-C Current](#) (page 122).
 - [USB Power Delivery](#) (page 121).
 - If the accessory does not have the potential for data communication with the device, it shall also support the *USB Battery Charging 1.2* specification.

21.4 Providing Power via USB Connectors

If the accessory connects via a USB-A receptacle, see [USB-A Receptacle](#) (page 150).

If the accessory connects via a USB-C receptacle, see [USB-C Receptacle](#) (page 153).

21.5 Labeling Multiple Connectors

If the accessory has multiple connectors with different device compatibilities, then the iPad-compatible connectors shall be labeled with the text 'iPad' unless it is physically impossible to connect an iPad to the iPhone/iPod compatible connectors.

21.6 Fast Charge for iPhone (18 W)

Power-providing accessories may advertise Fast Charge for iPhone (<https://support.apple.com/en-us/HT208137>) if they:

- Support [USB Power Delivery](#) (page 121).
- Supply 18 W (2 A at 9.0 V) using USB-PD.
- Claim compatibility with at least one of the following iPhone models:
 - iPhone 12 Pro Max
 - iPhone 12 Pro
 - iPhone 12
 - iPhone 12 mini
 - iPhone SE (2nd generation)
 - iPhone 11 Pro Max
 - iPhone 11 Pro
 - iPhone 11
 - iPhone XS Max
 - iPhone XS
 - iPhone XR
 - iPhone X
 - iPhone 8 Plus
 - iPhone 8

21.7 Overcurrent and Short Circuit Protection

Figure 21-1 Overcurrent and Short Circuit Protection

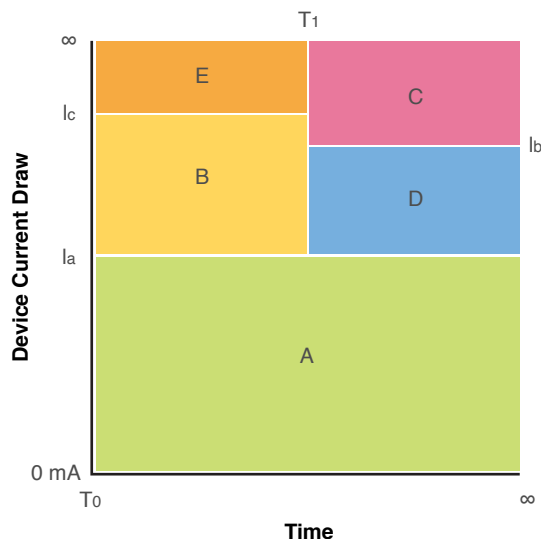

Power-providing accessories shall implement overcurrent and short circuit protection for each region in [Figure 21-1](#) (page 79) according to [Table 21-1](#) (page 79), [Table 21-2](#) (page 79), and [Table 21-3](#) (page 79).

Table 21-1 Overcurrent/Short Circuit Protection Current Thresholds

| Threshold | Definition |
|----------------|---|
| I _a | Nominal accessory output current (i.e. 1000 mA, 2100 mA, 2400 mA, 3000 mA). |
| I _b | I _a + 60%. |
| I _c | Lowest device current draw that will cause accessory output voltage (measured at Lightning Device Power) to drop below 2 V. |

Table 21-2 Overcurrent/Short Circuit Protection Time Thresholds

| Threshold | Definition |
|----------------|--|
| T ₀ | Start of any device current draw transient. |
| T ₁ | Accessory overcurrent/short circuit deglitch/debounce time, shall $\geq T_0 + 1$ ms. |

Table 21-3 Overcurrent/Short Circuit Protection Behaviors

| Region | Name | Accessory Behavior |
|--------|-----------------------|--|
| A | Normal Operation | Accessory shall not limit or shutdown output current. |
| B | Overcurrent Transient | Accessory shall not shutdown output current. Accessory may limit output current to I _a or higher. |

21. Device Power (Lightning)

21.8 Overcurrent and Short Circuit Protection Resets

| Region | Name | Accessory Behavior |
|--------|-------------------------|---|
| C | Overcurrent | Accessory shall shutdown output current. |
| D | Potential Overcurrent | Accessory may shutdown output current. |
| E | Potential Short Circuit | If Lightning Device Power voltage drops below 2 V, the accessory may trigger short circuit protection. Accessories shall not trigger short circuit protection on device current draw. |

21.8 Overcurrent and Short Circuit Protection Resets

Accessory overcurrent and short circuit protection shall reset without mechanical intervention.

21.9 Power State Changes

Accessories shall not change the amount of power provided to a device unless:

- Direct user action is taken to turn the accessory on or off.
- An external power source (such as mains electricity or battery) is connected to or disconnected from the accessory.
- The accessory's internal power source (such as a battery) is depleted or loaded to the point where it is no longer capable of supplying its declared power providing capability or is now capable of supplying more power than previously declared.

22. Location Information

The location feature provides compatible accessories with a means to provide external Global Navigation Satellite System (GNSS) information and other sensor data (like speed) in the form of National Marine Electronics Association (NMEA) sentences to devices. Devices that support this feature can take advantage of this additional information to augment their built-in location services. For example, some external Location-enabled accessories can provide more accurate or more frequent position updates. Additionally, devices can conserve power by using location information from a self-powered external accessory instead of using on-board positioning technologies.

See the [Accessory Interface Specification](#) (page 16) for more information.

23. MagSafe Attach

The following devices support MagSafe Attach:

- iPhone 12 Pro Max
- iPhone 12 Pro
- iPhone 12
- iPhone 12 mini

MagSafe [Cases](#) (page 24) shall:

- Claim compatibility with a MagSafe-capable device.
- Integrate a [MagSafe Case Magnet Array](#) (page 83).

Other MagSafe accessories shall:

- Claim compatibility with a MagSafe-capable device.
- Integrate a [MagSafe Accessory Magnet Array](#) (page 89).

Apple recommends the following magnet array vendors:

- Ningbo Sanhuan Magsound Industry&Trade Co., Ltd. (<http://www.magsound.com>)
- Phone In Mag Electronics Co., Ltd. (<http://www.phonein.com.tw>)
- Quadrant Solutions, Inc. (<https://www.quadrant.us>)

23.1 MagSafe Case Magnet Array

Figure 23-1 MagSafe Case Magnet Array

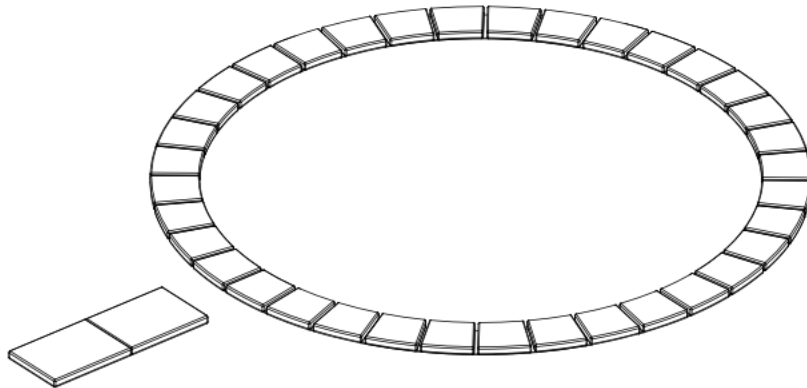

23.1.1 Product Design

All cases that integrate a MagSafe case magnet array shall:

- Enclose the device.
- Have a uniform maximum thickness of 2.1 mm. Apple recommends 2.0 mm.
- Firmly attach to the device without relying on the magnets.
- Not integrate magnets on the back of the case other than the MagSafe magnets.
- Comply with requirements for [Cases](#) (page 24).
- Work with:
 - Apple MagSafe Charger.
 - iPhone Leather Wallet.

23.1.2 Mechanical

All magnets that are part of the MagSafe case magnet array shall be positioned in the same plane.

The case and MagSafe case magnet array shall enable MagSafe accessories to magnetically self align within a 1.55 mm radial maximum.

23. MagSafe Attach

23.1 MagSafe Case Magnet Array

23.1.2.1 Magnets

All MagSafe case magnets shall be N45SH NdFeB with a 7 μm - 13 μm NiCuNi plating finish (or similar) and shall meet the requirements in [Table 23-1](#) (page 84).

Table 23-1 Magnet Properties

| Property | Minimum | Maximum |
|----------|-----------|----------|
| Br | 13.2 kGs | 13.6 kGs |
| Hcb | 12.75 kOe | |
| Hcj | 20.50 kOe | |
| BHmax | 43 MGOe | 46 MGOe |

23.1.2.2 Magnet Array

The magnets shall be positioned in the case following the dimensions and polarity shown in [Figure 23-2](#) (page 85), [Figure 23-3](#) (page 86) and [Figure 23-4](#) (page 86).

23. MagSafe Attach

23.1 MagSafe Case Magnet Array

Figure 23-2 MagSafe Magnet Array Dimensions

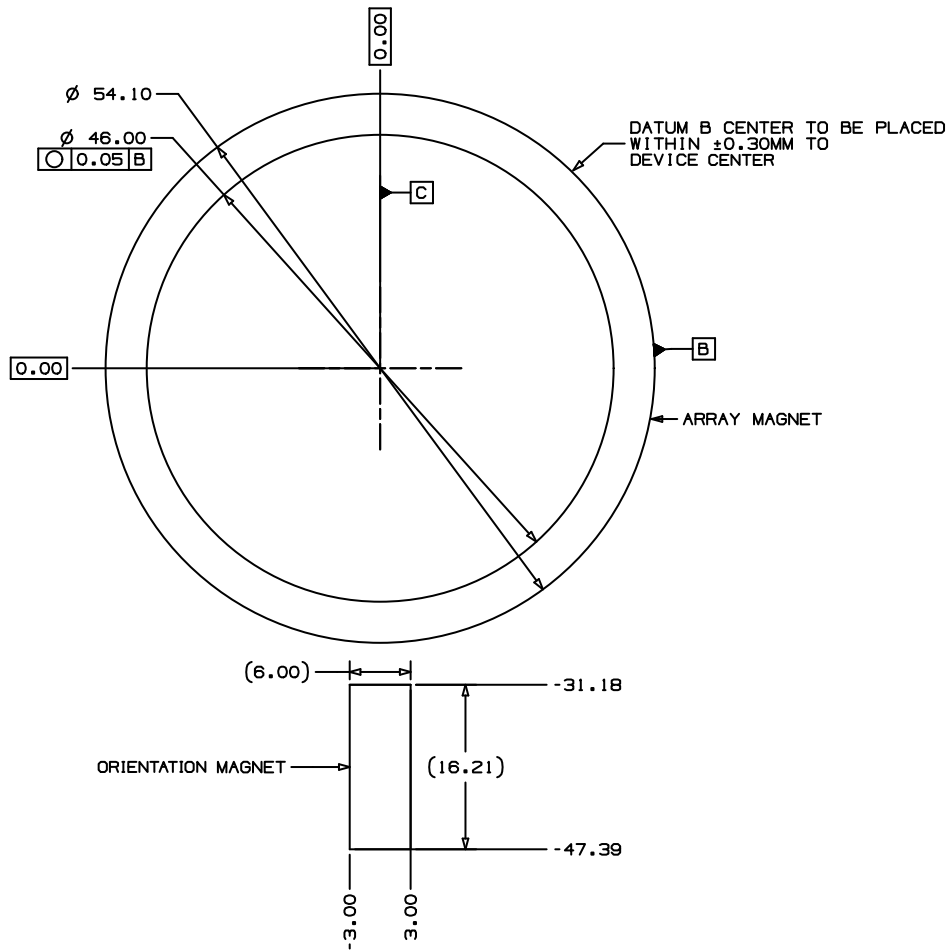

23. MagSafe Attach

23.1 MagSafe Case Magnet Array

Figure 23-3 MagSafe Magnet Ring Dimensions and Polarity

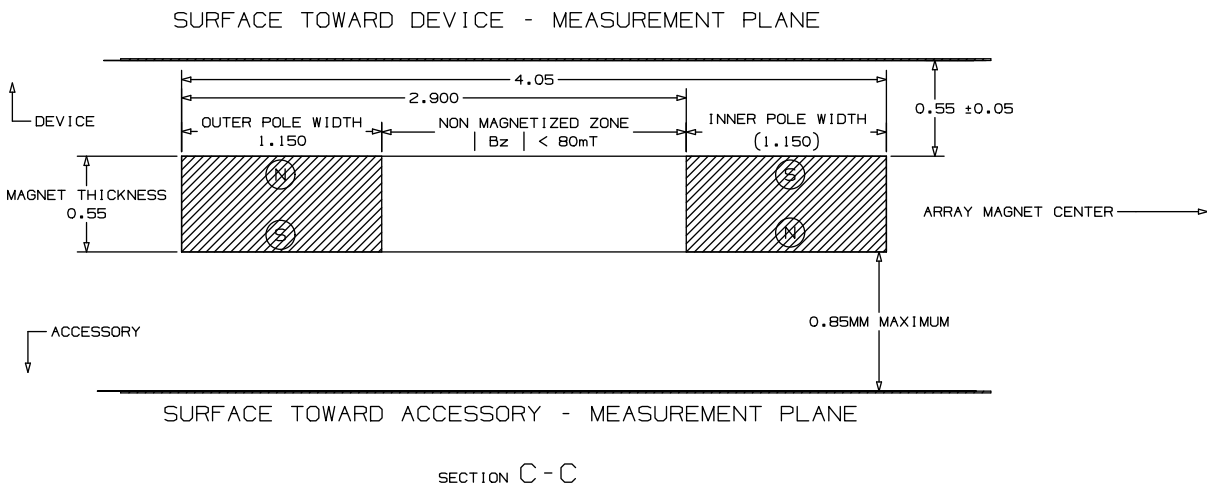
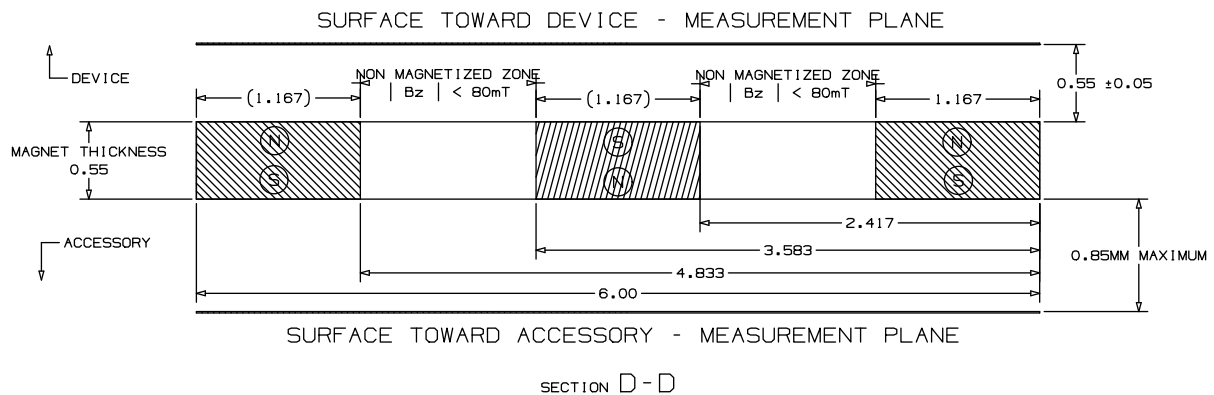

Figure 23-4 MagSafe Orientation Magnet Dimensions and Polarity



The flux density of a MagSafe case magnet ring shall comply with [Table 23-2](#) (page 87) and [Table 23-3](#) (page 88) across the 8 lines (S1 - S8) in [Figure 23-5](#) (page 87).

23. MagSafe Attach

23.1 MagSafe Case Magnet Array

Figure 23-5 MagSafe Flux Density Measurement Plane

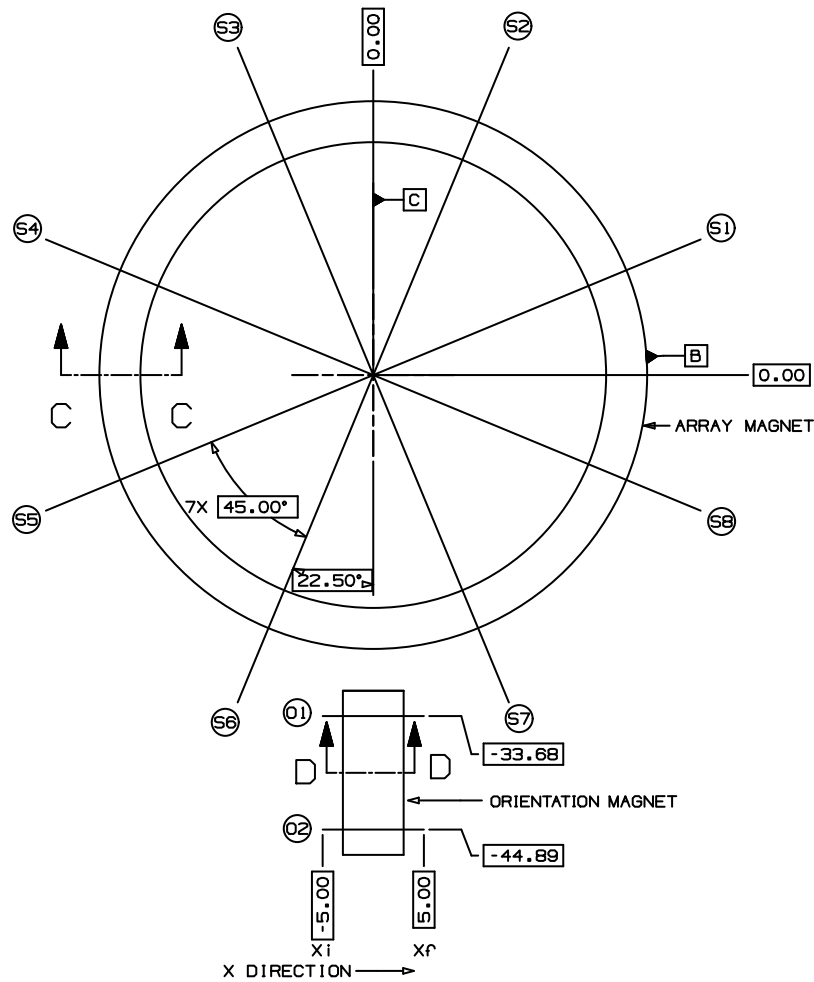

Table 23-2 Device side flux density at 0.55 mm from magnet ring surface

| Minimum r | Maximum r | Minimum Bz | Maximum Bz | Minimum Bxy | Maximum Bxy |
|-----------|-----------|------------|------------|-------------|-------------|
| | 19.5 mm | -0.020 T | 0.020 T | | 0.025 T |
| 19.5 mm | 23 mm | | | | 0.075 T |
| 23 mm | 24 mm | -0.170 T | -0.125 T | | |
| 24 mm | 26 mm | | | 0.095 T | 0.1325 T |
| 26 mm | 27 mm | 0.125 T | 0.170 T | | |
| 27 mm | 30 mm | | | | 0.075 T |
| 30 mm | | -0.020 T | 0.000 T | | 0.025 T |

23. MagSafe Attach

23.1 MagSafe Case Magnet Array

Table 23-3 Accessory side flux density at 0.80 mm from magnet ring surface

| Minimum r | Maximum r | Minimum Bz | Maximum Bz | Minimum Bxy | Maximum Bxy |
|-----------|-----------|------------|------------|-------------|-------------|
| | 19.5 mm | -0.020 T | 0.020 T | | 0.025 T |
| 19.5 mm | 23 mm | | | | 0.065 T |
| 23 mm | 24 mm | -0.120 T | -0.085 T | | |
| 24 mm | 26 mm | | | 0.070 T | 0.100 T |
| 26 mm | 27 mm | 0.85 T | 0.120 T | | |
| 27 mm | 30 mm | | | | 0.065 T |
| 30 mm | | -0.020 T | 0.000 T | | 0.025 T |

The flux density of a MagSafe case orientation magnet shall comply with [Table 23-4](#) (page 88) and [Table 23-5](#) (page 88) across the 2 lines (O1 and O2) in [Figure 23-5](#) (page 87).

Table 23-4 Device side flux density at 0.55 mm from orientation magnet surface

| Minimum x | Maximum x | Minimum Bz | Maximum Bz | Minimum Bxy | Maximum Bxy |
|-----------|-----------|------------|------------|-------------|-------------|
| | -5.0 mm | -0.020 T | 0.020 T | | 0.025 T |
| -5.0 mm | -4.5 mm | -0.020 T | 0.020 T | | |
| -4.5 mm | -2.75 mm | | | 0.080 T | 0.110 T |
| -2.75 mm | -2.0 mm | 0.125 T | 0.175 T | | |
| -2.0 mm | -0.5 mm | | | 0.110 T | 0.155 T |
| -0.5 mm | 0.5 mm | -0.1925 T | -0.140 T | | |
| 0.5 mm | 2.0 mm | | | 0.110 T | 0.155 T |
| 2.0 mm | 2.75 mm | 0.125 T | 0.175 T | | |
| 2.75 mm | 4.0 mm | | | 0.080 T | 0.110 T |
| 4.0 mm | 5.0 mm | -0.020 T | 0.020 T | | |
| 5.0 mm | | -0.020 T | 0.020 T | | 0.025 T |

Table 23-5 Accessory side flux density at 0.80 mm from orientation magnet surface

| Minimum x | Maximum x | Minimum Bz | Maximum Bz | Minimum Bxy | Maximum Bxy |
|-----------|-----------|------------|------------|-------------|-------------|
| | -5.0 mm | -0.020 T | 0.020 T | | 0.025 T |
| -5.0 mm | -4.5 mm | -0.020 T | 0.020 T | | |
| -4.5 mm | -2.75 mm | | | 0.050 T | 0.070 T |
| -2.75 mm | -2.0 mm | 0.085 T | 0.120 T | | |
| -2.0 mm | -0.5 mm | | | 0.0825 T | 0.115 T |
| -0.5 mm | 0.5 mm | -0.140 T | -0.0975 T | | |
| 0.5 mm | 2.0 mm | | | 0.0825 T | 0.115 T |
| 2.0 mm | 2.75 mm | 0.085 T | 0.120 T | | |

23. MagSafe Attach

23.2 MagSafe Accessory Magnet Array

| Minimum x | Maximum x | Minimum Bz | Maximum Bz | Minimum Bxy | Maximum Bxy |
|-----------|-----------|------------|------------|-------------|-------------|
| 2.75 mm | 4.0 mm | | | 0.050 T | 0.070 T |
| 4.0 mm | 5.0 mm | -0.020 T | 0.020 T | | |
| 5.0 mm | | -0.020 T | 0.020 T | | 0.025 T |

23.1.2.3 Magnetic Force

The force normal to the back of the case that is needed to dislodge a MagSafe accessory, such as the Apple MagSafe Charger, shall meet the requirements in [Table 23-6](#) (page 89).

Table 23-6 Magnetic force

| Scenario | Minimum | Maximum |
|-------------------------|---------|---------|
| Case attached to device | 800 gf | 1100 gf |
| Case only | 600 gf | 900 gf |

23.1.3 Magnetic Interference

All cases with an integrated MagSafe magnet array shall not interfere with:

- Device wireless charging functionality.
- Magnetic stripe cards in an attached iPhone Leather Wallet.

23.2 MagSafe Accessory Magnet Array

Figure 23-6 MagSafe Accessory Magnet Array Options

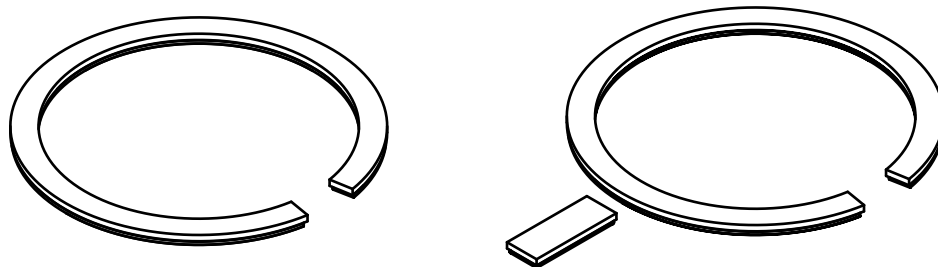

The MagSafe accessory magnet array may be implemented via a:

- [Magnet Ring](#) (page 90), enabling the device and accessory to be attached in any orientation.
- [Magnet Ring](#) (page 90) plus an [Orientation Magnet](#) (page 92), enabling the device and accessory to be attached at a specific orientation.

23.2.1 Product Design

All accessories integrating the MagSafe accessory magnet array shall not enclose the device.

23.2.2 Mechanical

All magnets that are part of the MagSafe accessory magnet array shall be positioned in the same plane.

The MagSafe accessory's [Magnet Ring](#) (page 90) shall magnetically self align to the device's magnet ring within a 1.55 mm radial maximum.

23.2.2.1 Magnets

All MagSafe accessory magnets shall be N48H NdFeB with a 7 μm - 13 μm NiCuNi plating finish (or similar) and shall meet the requirements in [Table 23-7](#) (page 90).

Table 23-7 Magnet Properties

| Property | Minimum | Maximum |
|----------|-----------|----------|
| Br | 13.7 kGs | 14.1 kGs |
| Hcb | 13.25 kOe | |
| Hcj | 17 kOe | |
| BHmax | 45 MGOe | 48 MGOe |

23.2.2.2 Magnet Ring

The magnet ring shall be positioned in the accessory following the dimensions and polarity shown in [Figure 23-7](#) (page 91) and [Figure 23-8](#) (page 92).

23. MagSafe Attach

23.2 MagSafe Accessory Magnet Array

Figure 23-7 MagSafe Magnet Ring Dimensions

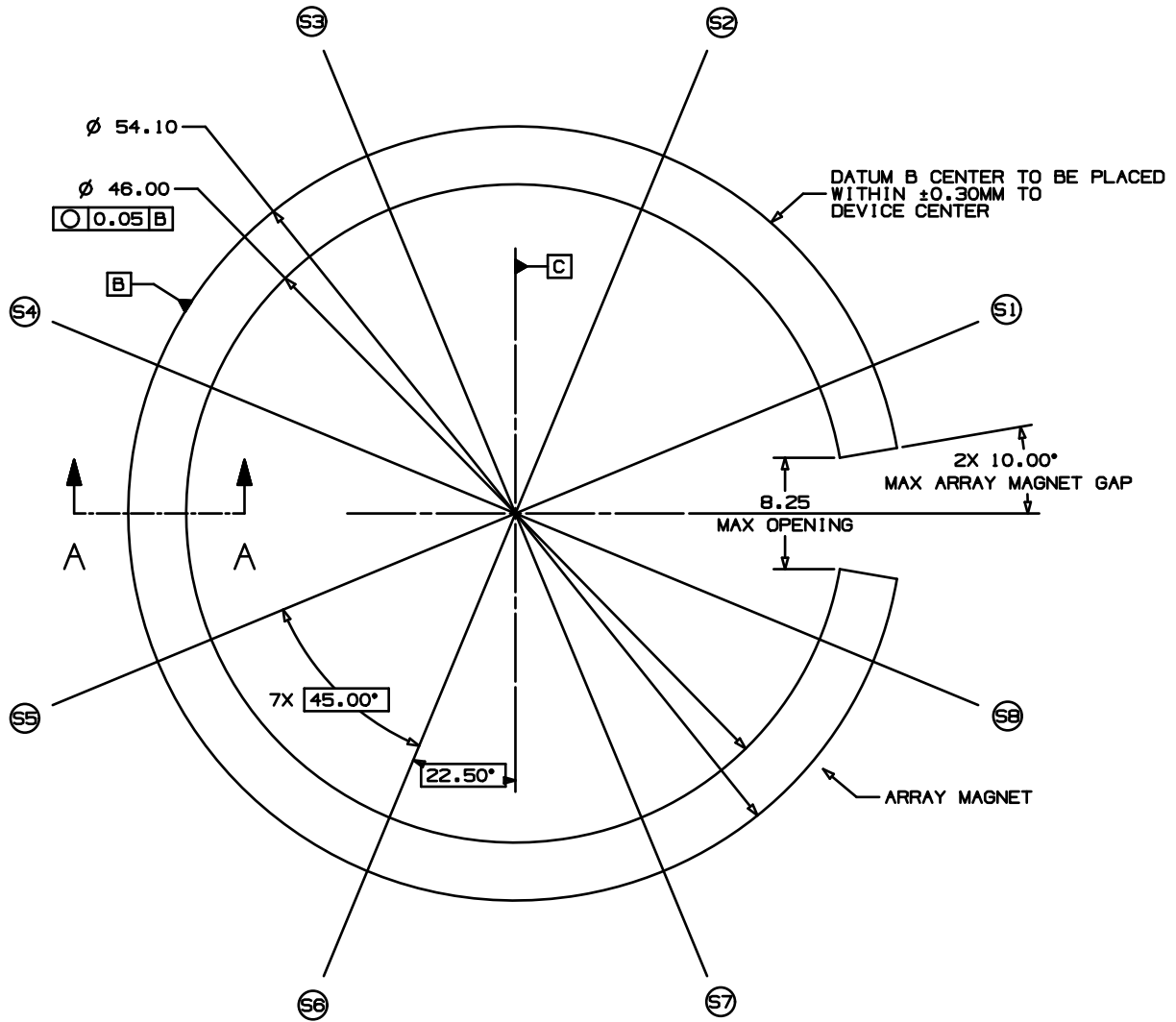

23. MagSafe Attach

23.2 MagSafe Accessory Magnet Array

Figure 23-8 MagSafe Magnet Ring Dimensions and Polarity

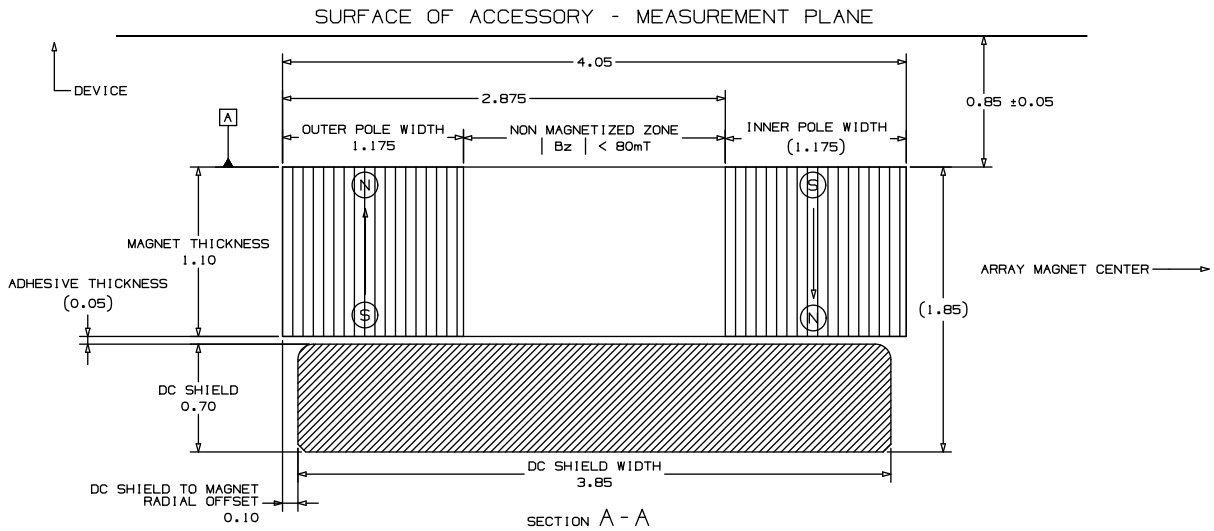

See [DC Shield](#) (page 95) for additional requirements of the DC shield specified in [Figure 23-8](#) (page 92).

The flux density of a MagSafe accessory magnet ring shall comply with [Table 23-8](#) (page 92) across the 8 lines (S1 - S8) in [Figure 23-7](#) (page 91).

Table 23-8 Flux density at 0.85 mm from magnet ring surface

| Minimum r | Maximum r | Minimum Bz | Maximum Bz | Minimum Bxy | Maximum Bxy |
|-----------|-----------|------------|------------|-------------|-------------|
| 0 mm | 19.5 mm | -0.025 T | 0.025 T | | 0.025 T |
| 19.5 mm | 23 mm | | | | 0.075 T |
| 23 mm | 24.5 mm | -0.215 T | -0.155 T | | |
| 24.5 mm | 25.5 mm | | | 0.170 T | 0.215 T |
| 25.5 mm | 27 mm | 0.155 T | 0.215 T | | |
| 27 mm | 30 mm | | | | 0.075 T |
| 30 mm | | -0.025 T | 0.025 T | | 0.025 T |

23.2.2.3 Orientation Magnet

If orientation magnets are included, they shall be positioned according to [Figure 23-9](#) (page 93) and [Figure 23-10](#) (page 94).

23. MagSafe Attach

23.2 MagSafe Accessory Magnet Array

Figure 23-9 MagSafe Orientation Magnet Dimensions

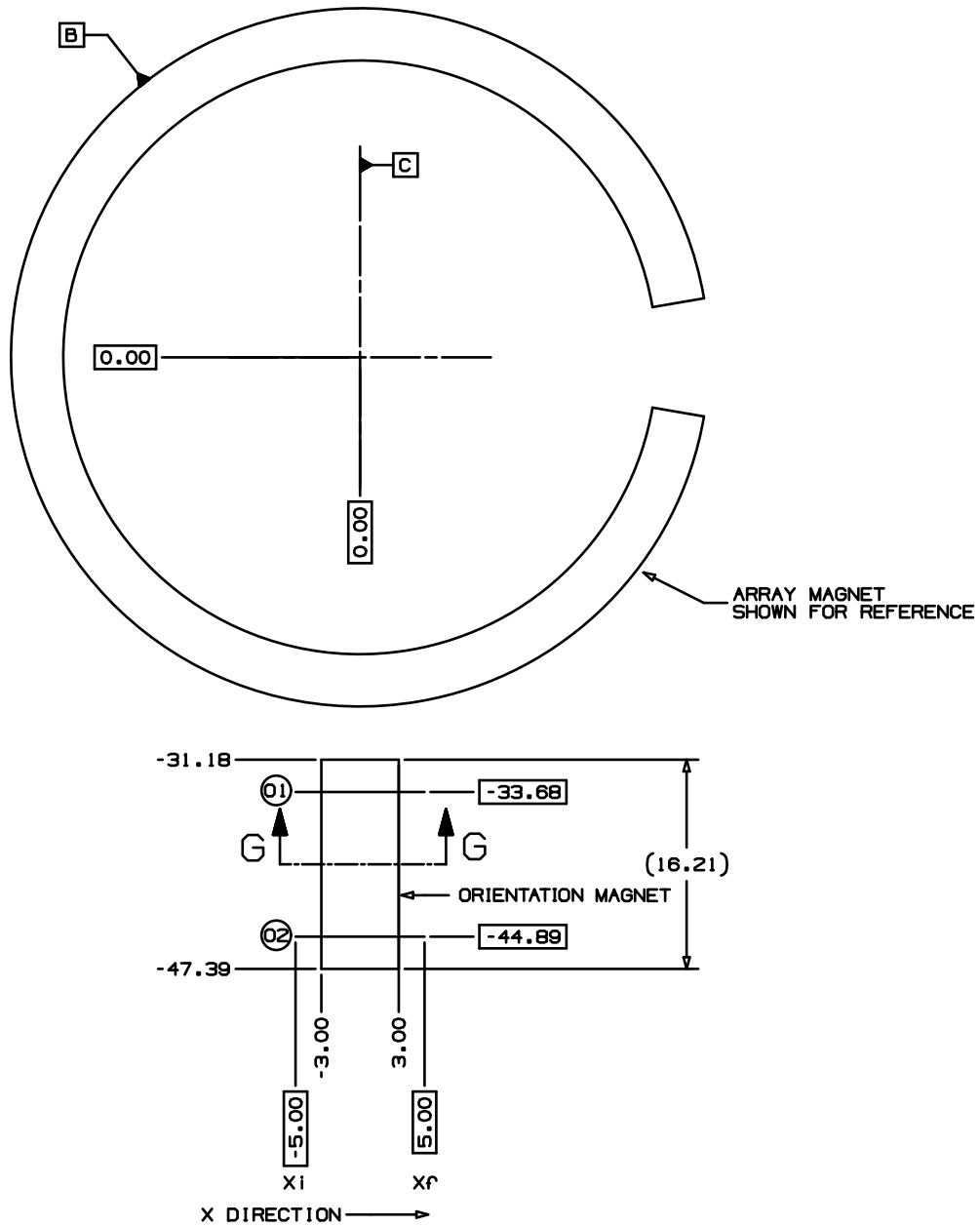

23. MagSafe Attach

23.2 MagSafe Accessory Magnet Array

Figure 23-10 MagSafe Orientation Magnet Dimensions and Polarity

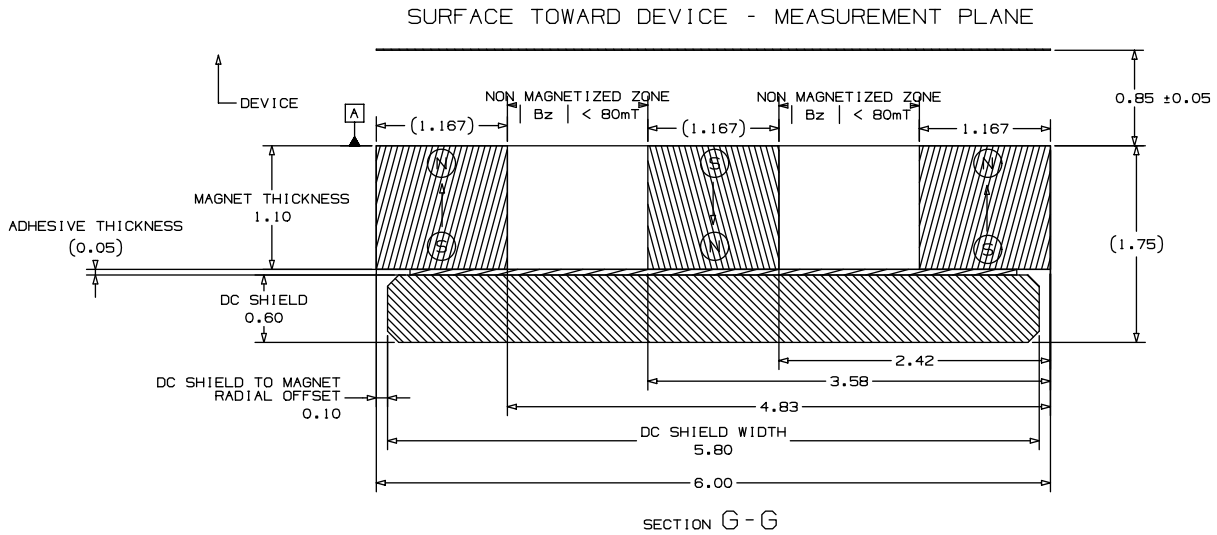

See [DC Shield](#) (page 95) for additional requirements of the DC shield specified in [Figure 23-10](#) (page 94).

The flux density of a MagSafe accessory orientation magnet shall comply with [Table 23-9](#) (page 94) across the 2 lines (O1 and O2) in [Figure 23-9](#) (page 93).

Table 23-9 Flux density at 0.85 mm from orientation magnet surface

| Minimum x | Maximum x | Minimum Bz | Maximum Bz | Minimum Bxy | Maximum Bxy |
|-----------|-----------|------------|------------|-------------|-------------|
| | -5.0 mm | -0.025 T | 0.025 T | | 0.025 T |
| -5.0 mm | -4.5 mm | -0.025 T | 0.025 T | | |
| -4.5 mm | -3.0 mm | | | 0.0625 T | 0.0875 T |
| -3.0 mm | -2.0 mm | 0.145 T | 0.195 T | | |
| -2.0 mm | -0.5 mm | | | 0.165 T | 0.215 T |
| -0.5 mm | 0.5 mm | -0.250 T | -0.185 T | | |
| 0.5 mm | 2.0 mm | | | 0.165 T | 0.215 T |
| 2.0 mm | 3.0 mm | 0.145 T | 0.195 T | | |
| 3.0 mm | 4.0 mm | | | 0.0625 T | 0.0875 T |
| 4.0 mm | 5.0 mm | -0.025 T | 0.025 T | | |
| 5.0 mm | | -0.025 T | 0.025 T | | 0.025 T |

23.2.2.4 Magnetic Force

The force normal to the back of the device that is needed to dislodge the MagSafe accessory shall meet the requirements in [Table 23-10](#) (page 95).

Table 23-10 Magnetic force

| Scenario | Minimum | Maximum |
|------------------------------|---------|---------|
| Accessory attached to device | 650 gf | 900 gf |

23.2.2.5 DC Shield

The DC shield shall be low carbon steel (1010, DT4 or similar), per ASTM848, with a 5 µm - 10 µm Ni plating finish or similar.

The DC shield shall have a saturation flux density (B_{sat}) of at least 2.0 T.

23.3 Test Procedures

23.3.1 MagSafe Case Magnet Array

23.3.1.1 Case Thickness

23.3.1.1.1 Equipment

- Digital thickness gauge, such as:
 - Mitutoyo 547-500S.
 - Neoteck NTKTL495.
 - Clockwise Tools DTGR-0055.

23.3.1.1.2 Procedure

1. Using the digital thickness gauge, verify that the thickness is less than or equal to 2.1 mm at:
 - 4 points along the magnet ring.
 - 2 points along the orientation magnet.

23.3.1.2 Magnetic Stripe Cards in iPhone Leather Wallet

23.3.1.2.1 Equipment

- Device.
- iPhone Leather Wallet.
- Low Coercivity Magnetic stripe (LoCo) cards, such as cards from the following vendors:
 - American Card Service.

- Allsafe.
- CI Solutions.
- PSA.
- LoCo card reader/writer, such as:
 - Q-card Mag3x.
 - Magtek InSpec 9000.
 - Misiri X6BT.
 - Deftun MSR605X.

23.3.1.2.2 Procedure

1. Attach the accessory to the device.
2. Repeat this procedure for 3 different brands of LoCo cards:
 - a. Write to the LoCo card and confirm readability.
 - b. Insert the LoCo card into the iPhone Leather Wallet with the magnetic stripe facing the magnets of the iPhone Leather Wallet.
 - c. Place additional cards into the pocket to ensure LoCo card is in contact with the magnet side of the iPhone Leather Wallet.
 - d. Attach the iPhone Leather Wallet to the accessory (attached to the device).
 - e. Wait 10 seconds.
 - f. Remove the iPhone Leather Wallet from the accessory.
 - g. Remove the LoCo card from the iPhone Leather Wallet.
 - h. Verify that the LoCo card can be read and that it displays the correct information.

24. Media Library Access

The media library feature allows accessories to download the metadata contents of a device's media libraries (not the media items themselves) and request playback of media items. The feature is divided into the following sub-features:

- Media Library Information informs the accessory about available media libraries on the device.
- Media Library Updates provide an accessory with an updated view of the contents of a particular media library.
- Media Library Playback allows the accessory to request playback of one or more items from the media library.

See the [Accessory Interface Specification](#) (page 16) for more information.

25. Now Playing Updates

The Now Playing feature enables an accessory to display information about the current "Now Playing" media source and media item on a device. Media sources include both the built-in Music and Video apps on devices and certain third-party iOS apps that support the generation of Now Playing metadata, see *MPNowPlayingInfoCenter* in the iOS SDK documentation. Accessories shall be prepared for the Now Playing media source and media item to change at any time, whether the accessory requested the change or not.

See the [Accessory Interface Specification](#) (page 16) for more information.

26. Out-of-Band Bluetooth Pairing

Accessories with the ability to connect to a device via Bluetooth and a wired transport should use the Out-of-Band Bluetooth Pairing feature to simplify Bluetooth connection setup.

For example, Lightning to USB charge/sync cables or Lightning to USB accessory cables can be used to exchange Bluetooth pairing information upon initial connection. This may reduce or eliminate the need for instruction manuals to describe how to:

- Put the accessory into a discoverable and pairable mode.
- Initiate Bluetooth pairing on the device via the Settings app.
- Download the accessory's companion app and initiate pairing from the app.

See the [Accessory Interface Specification](#) (page 16) for more information.

27. Siri

Siri enables a user to have rich interactions with a device by primarily using their voice.

Accessories supporting Siri shall not use an icon that resembles the Siri microphone icon.

The rest of this chapter is applicable to accessories that support Siri over Bluetooth using HFP commands.

To support Siri using other transports and protocols, the accessory developer shall be a member of the Apple MFi licensing program. See <https://developer.apple.com/programs/mfi> for further information.

27.1 Enabling Custom Siri Commands

Every accessory that supports Siri over Bluetooth using HFP commands shall support [HFP Command AT+XAPL](#) (page 69). The device will use the information sent by this command to enable and disable custom commands related to Siri.

To receive Siri status events, the accessory shall send the AT+XAPL command after making a successful HFP Service Level Connection (SLC) to the device. The accessory should send an AT+XAPL command first, before sending any of the additional Siri-specific commands described below.

27.2 Obtaining Siri Availability Information

After establishing an HFP profile connection, an accessory can determine if Siri is available and enabled on a device. It can also receive notifications of changes in Siri status. If Siri is disabled, Voice Control will be activated instead.

27.2.1 Obtaining Status Information at Connection

The accessory should send the following command after making a successful HFP profile (SLC) connection and sending an AT+XAPL command.

27.2.1.1 HFP Command AT+APLSIRI?

Description: AT command to retrieve Siri status information.

Initiator: accessory

Format: AT+APLSIRI?

Response: +APLSIRI : *value*

Defined Values:

- 0 = Siri is not available on this platform.
- 1 = Siri is available and enabled.
- 2 = Siri is available but not enabled.

Example: +APLSIRI : 1 (Siri is available and enabled)

27.2.2 Receiving Siri Availability Updates from the Device

After initialization has been completed, the device will send the accessory the following notification if there is a change in Siri status. This notification will be provided only if the accessory has requested Siri status (by sending AT+APLSIRI?) at least once after connection, and if the device has reported that Siri is available and enabled.

27.2.2.1 HFP Command +APLSIRI

Description: Unsolicited event indicating a change in Siri status.

Initiator: Device

Format: +APLSIRI : *value*

Defined Values:

- 1 = Siri is available and enabled.
- 2 = Siri is available but not enabled.

Example: +APLSIRI : 2 (Siri is available but not enabled)

Figure 27-1 Siri is Disabled/Enabled from the Device's Settings

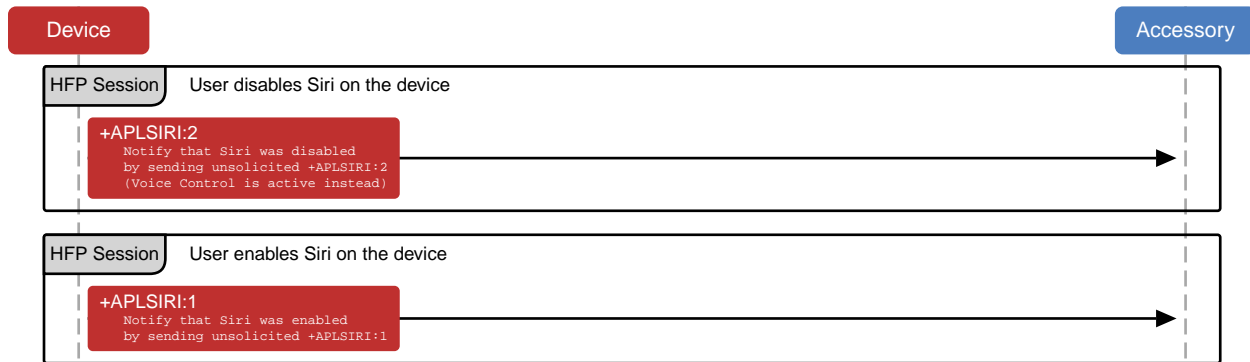

27.3 Initiating a Siri Session

Once support for Siri is established on both the accessory and the device, a Siri session can be started from either one.

27.3.1 Initiating a Session from the Accessory

The accessory should only initiate a Siri session as a result of a direct user action.

The accessory shall use the voice recognition command `AT+BVRA` defined in the Bluetooth *Hands-Free Profile* specification (*Hands-Free Profile 1.6* profile specification, section 4.25) to initiate a Siri session.

The HFP profile shall be connected and SLC shall exist.

The accessory should use the following command sequence:

- The accessory sends an `AT+BVRA=1` command to the device.
- The device sends an OK response.
- The device launches a Siri session and creates a Synchronous Connection (SCO) for the audio.
- If the Siri session is not finished, the accessory shall send `AT+BVRA=1` to continue the conversation. This may need to happen multiple times.
- When the Siri session is finished, the device sends a `+BVRA:0` result code to the accessory.
- The device disconnects the SCO connection.

While a Siri session is active, the accessory shall let the user continue the conversation and ask follow up questions within the current context. In order to do so, the accessory shall be able to send an `AT+BVRA=1` command to the device even after Siri has been already activated and before `+BVRA:0` is received. [Figure 27-2](#) (page 103) shows an overview of the interaction when Siri is triggered from the accessory, the running session was continued twice and once Siri was finished, the device dismissed the session.

Figure 27-2 Initiating a Siri Session from the Accessory

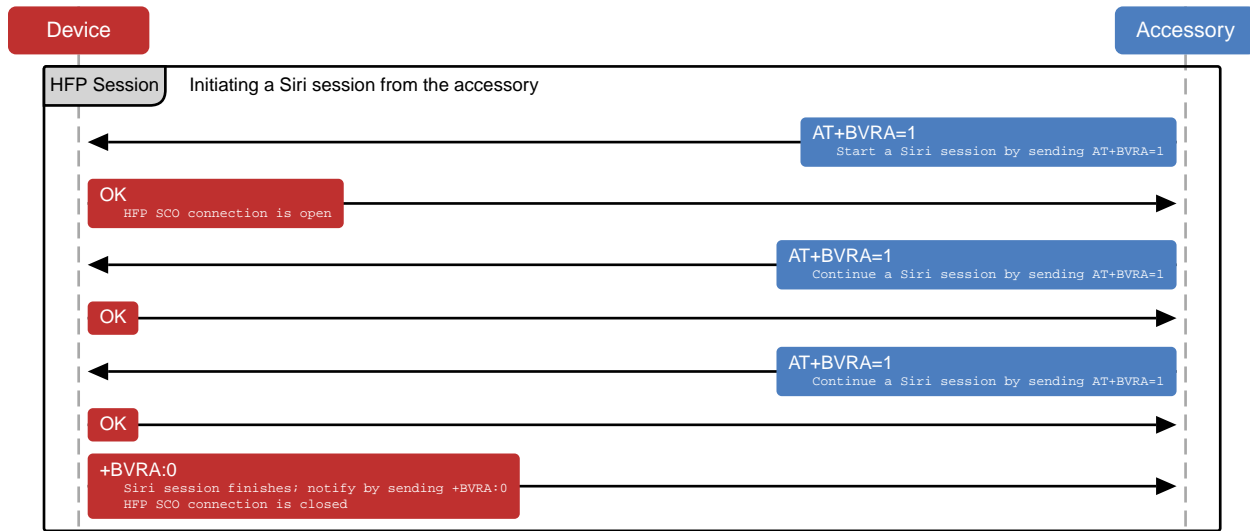

27.3.2 Initiating a Session from the Device

If the accessory supports voice recognition commands, the device sends a `+BVRA` event to indicate the start of a Siri session. The accessory shall enable support for voice recognition and indicate it in its feature response as described in the Bluetooth *Hands-Free Profile 1.6* specification, section 4.34.1, "Bluetooth Defined AT Capabilities." Specifically, the HFP profile shall be connected, SLC shall exist, and voice recognition activation (bit 3) shall be enabled in the `AT+BRSF` command. The device will not use virtual call functionality for the Siri session if voice recognition activation is supported by the accessory.

The accessory should expect the following command sequence:

- The device sends a `+BVRA:1` event to the accessory.
- The device launches a Siri session and creates a SCO connection for the audio.
- When the Siri session is finished, the device sends a `+BVRA:0` result code to the accessory.
- The device disconnects the SCO connection.

Figure 27-3 Initiating a Siri Session from the Device

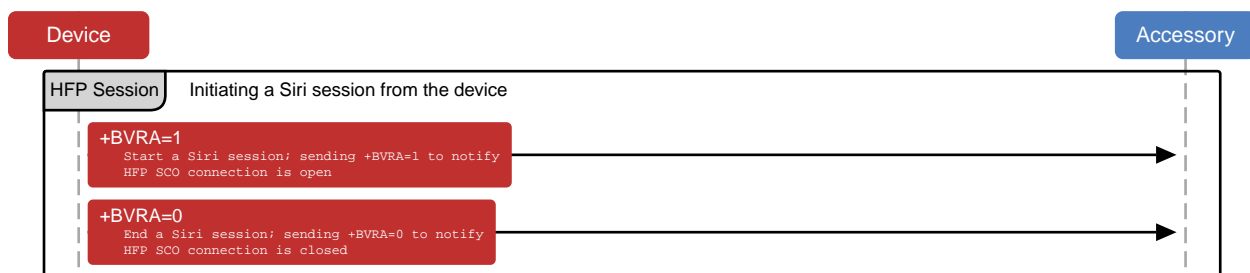

27.3.3 Ending a Session from the Accessory

Once a Siri session is running the accessory shall be capable of ending the session by sending an `AT+BVRA=0` command to the device. [Figure 27-4](#) (page 104) shows an example of ending a running Siri session from the accessory. The accessory should only end an active session as a result of a direct user action.

Figure 27-4 Ending a Siri Session from the Accessory

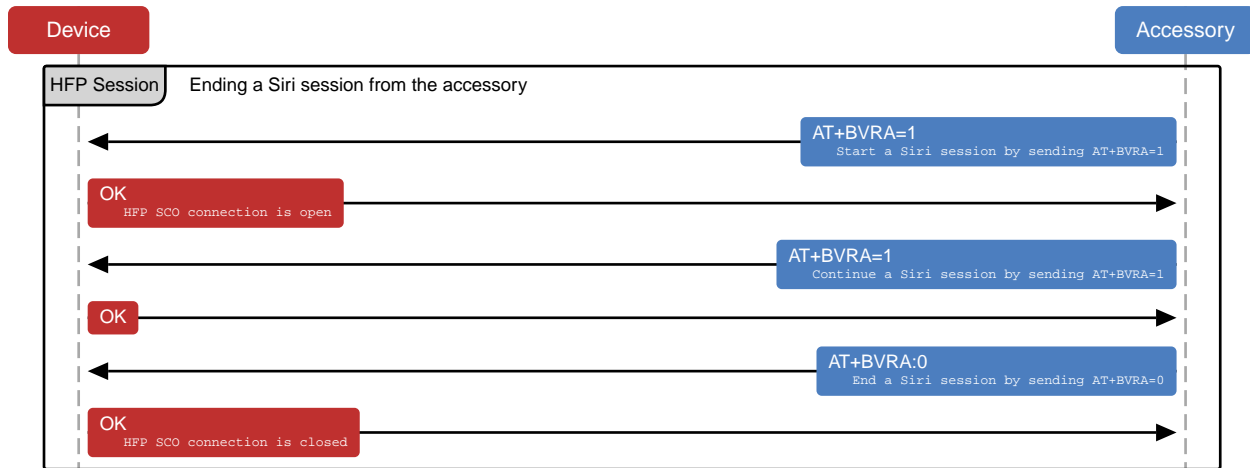

27.4 Siri Eyes Free Mode

Siri Eyes Free mode is a feature to control Siri responses that include display information and can be enabled or disabled as needed. In Siri Eyes Free mode, the user experience is tailored towards a driving scenario and interactions with Siri are done primarily via voice to minimize the need for the user to look at a screen. Siri Eyes Free mode is supported only for Bluetooth-enabled vehicle entertainment systems and should not be used by any other accessories. Siri Eyes Free should not be triggered via a voice command.

The device will listen for the HFP AT command `AT+APLEFM` to enable or disable Siri Eyes Free mode.

This command is used by the device to modify Siri responses that contain visual information or require user interaction. Suitable audio feedback and voice commands will be available to the user based on the Siri use case that was initiated.

Siri Eyes Free mode is disabled by default. Once the accessory has enabled Siri Eyes Free mode, it remains enabled for all subsequent Siri sessions initiated from the accessory until the accessory disables it or the Bluetooth connection is disconnected.

27.4.1 HFP Command AT+APLEFM

Description: An accessory sends this command to notify a device of the preferred state of Siri Eyes Free mode.

Initiator: accessory

Format: AT+APLEFM=*value*

Response: OK

Defined Values:

- 0x00 = Disable Siri Eyes Free mode.
- 0x01 = Enable Siri Eyes Free mode.
- 0x02-0xFF = reserved

Example: AT+APLEFM=1

27.5 Improving Voice Recognition

The microphone audio that the accessory sends to the device during a Siri session should be suitable for voice recognition. Audio requirements for optimal voice recognition may differ from requirements for optimal human perception (such as during a cellular phone call).

Filtering of the audio signal to remove echoes or feedback noise is acceptable.

To provide the best possible audio quality as Siri input, the accessory shall observe the following recommendations:

- **Echo cancellation and noise suppression (EC/NR):** Directional microphones and linear beamforming with microphone arrays giving improved SNR are recommended. Linear echo cancellation for reducing unwanted audio sources (such as audio output from the system) without having any other effect on the speech signal are also recommended. However, single channel noise reduction methods (such as spectrum subtraction) shall not be applied, as they will be detrimental to the speech recognition accuracy. Similarly, automatic gain control, residual echo suppression and attempts to blank out non-speech periods in the waveform shall not be applied.
- **Signal gain:** When adjusting signal levels, the accessory shall avoid artifacts, dropouts, and clipping in all circumstances. Automatic Gain Control is not recommended. If the accessory adjusts signal gain, the gain should be held constant across each spoken utterance. The nominal level measured at the uplink output of the accessory should be A-weighted -30 dB \pm 2 dB root-mean-square (RMS), expressed in units relative to full-scale (dBFS(A)). Alternatively, the nominal level may be 13 dB \pm 2 dB SLR if using the ITU measurement procedure.

- **Signal-to-noise ratio (SNR):** The average SNR should be greater than 20 dB. Below 20 dB, recognition rates will be impacted.
- **Reverberation:** An RT60 time less than 200 ms should be maintained.

27.5.1 Wide Band Speech Support

An accessory using Siri should support 16 kHz wide band speech audio for better audio quality and voice recognition performance. See the Bluetooth *Hands-Free Profile* 1.6 specification for details about wide band speech audio. Narrow band audio signal (8 kHz) is supported but not recommended.

27.6 Optimizing the Siri Experience

The start of a Siri session should not be accompanied by local beeps or verbal indications (such as an announcement of "...voice dialing...") from the accessory. When a Siri session becomes active, the device sends two beeps indicating that Siri is ready to receive instructions. Adding extra audible notifications only inserts delays in the system.

The accessory should wait for the device to end each Siri session.

The accessory should not send an AT+BVRA=0 command unless it is prompted to do so by user interaction.

The accessory should be capable of rendering audio within 200 ms of SCO connection activation to ensure that the user always hears the Siri introductory beeps.

27.7 Common Siri Applications

Siri can send messages, find points of interests, place phone calls, and much more. As Siri capabilities are constantly growing, additional use cases may become available after the initial integration. In Siri Eyes Free mode, some of these use cases may not be accessible as the user experience is tailored towards a driving scenario.

27.7.1 Initialization Procedure After Connection is Established

Figure 27-5 (page 107) outlines the sequence the accessory has to trigger to be able to use Siri on a device. After establishing an HFP profile connection, the accessory shall first enable the custom Siri commands by sending AT+XAPL and provide the features it supports. After a confirmation is received from the device, the accessory should determine Siri's availability with AT+APLSIRI?.

Vehicles with Bluetooth-enabled infotainment systems can also enable Siri Eyes Free Mode during initialization. This is detailed in [Figure 27-6](#) (page 107).

Figure 27-5 Siri Initialization Procedure

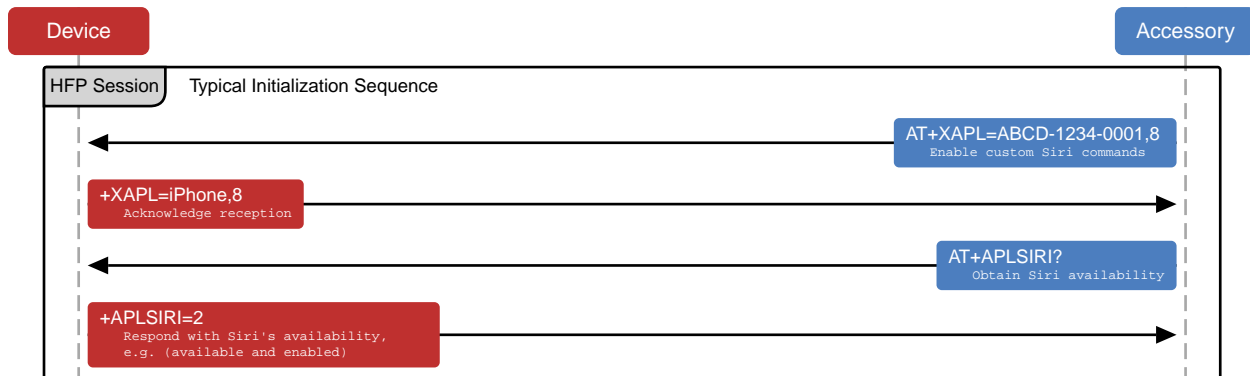
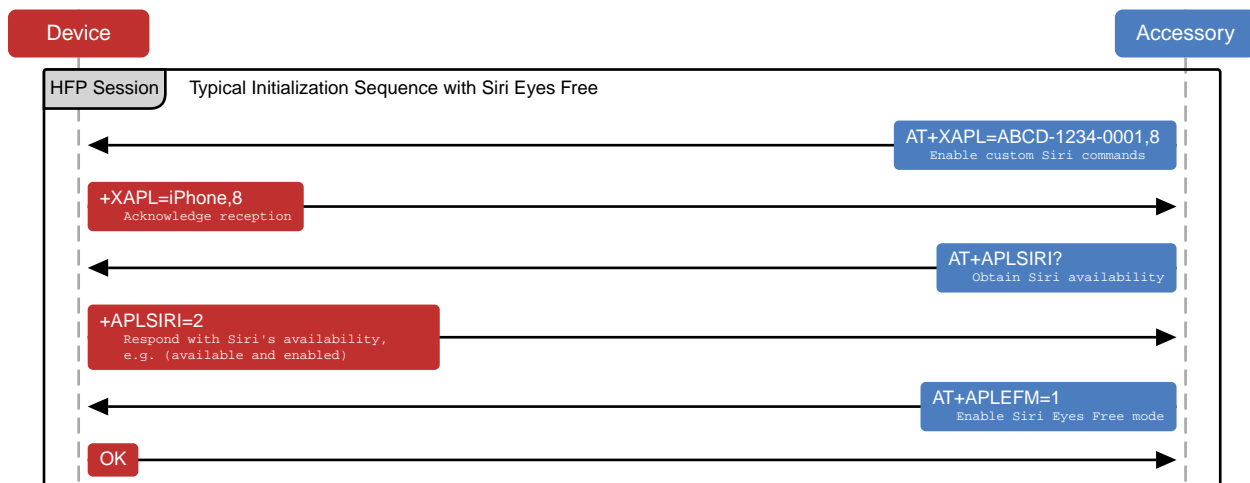

Figure 27-6 Siri Initialization Procedure with Siri Eyes Free



27.7.2 Phone Dialing Using Siri

Upon the user's request Siri can initiate an outgoing phone call. The device will initiate HFP call signaling to establish a phone call as described in [Bluetooth](#) (page 129). The accessory shall be able to transition to Hands-Free dialing at any time during or after a Siri session when signaled by the device.

27.7.3 Audio Routing and Media Playback Using Siri

Siri can control the media playback on a device, and if Siri determines that the user wants to play or pause music it will either start, pause or resume media playback. The device will send a notification to the accessory indicating a change in playback state and any associated track information. The accessory shall respond to those notifications, start or stop the music playback as requested, as well as update the correct playback state (e.g. shuffle, repeat).

The accessory shall not force a change in the playback state after a Siri session is ended. If music was playing before Siri was started, it shall continue playing, if it was paused, it shall remain paused.

After Siri starts music playback the accessory shall set its current audio route to match the audio source, depending on how audio is being received from the device (via Bluetooth or by a wired connection).

The available media playback notifications depend on the audio route being used:

- Bluetooth audio routes shall use the approach described in [Notifications](#) (page 137) and [Audio Data Received via A2DP Profile](#) (page 139).
- Wired audio routes shall use iAP2.

27.7.4 Turn-By-Turn Directions Using Siri

Siri can initiate active route guidance that will play turn-by-turn directions. In case the device is the active source and is already playing music, turn-by-turn directions will be mixed in as part of the audio stream. In case the device is not playing music, the accessory should be able to mix in turn-by-turn directions with the active audio source.

The device will notify the accessory to play turn-by-turn directions only over Bluetooth. Detailed information on how to distinguish between music playback and turn-by-turn notifications is available in [Notifications](#) (page 137).

27.8 User Interaction with Siri Eyes Free in a Vehicle

A vehicle that uses Siri Eyes Free mode shall integrate the Siri experience with the existing in-vehicle entertainment system and controls. The vehicle should provide a convenient interface to initiate, continue, and end a Siri session. Once a Siri session is running, the vehicle shall display a visual cue that voice recognition is in process. [Figure 27-7](#) (page 109) outlines how a Siri interaction should be designed.

Figure 27-7 Siri Eyes Free User Interaction

Initiate or continue a Siri session

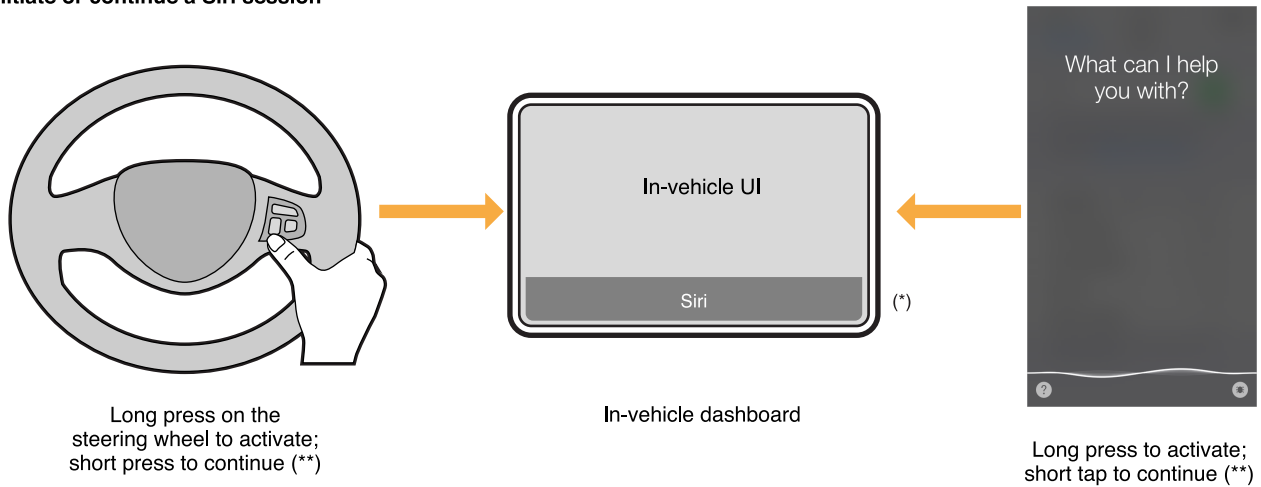

End a Siri session

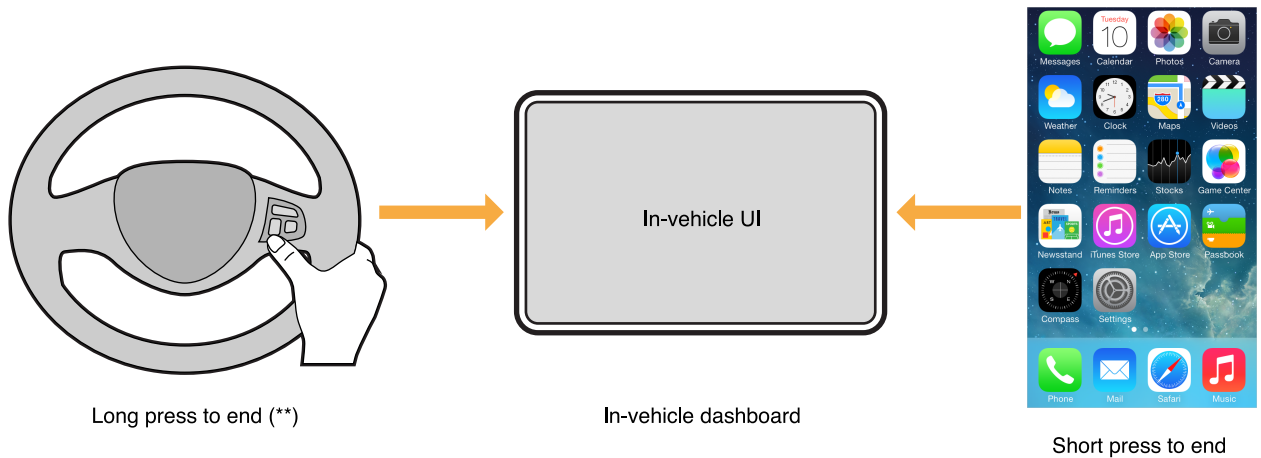

(*) If the accessory wishes to indicate that Siri is active, it shall do one of the following:

- Display the word 'Siri' (as capitalized) with no additional text or icon.
- Use generic text or icon that does not resemble the Siri microphone icon.

(**) If the vehicle is equipped with steering wheel controls, the steering wheel shall have a dedicated button or a long-press action on a button to start, continue and end a Siri session. The button long-press shall be 600 ms or less. If no steering wheel controls are available, a soft button shall be available within the in-vehicle user interface to start, continue or end a Siri session.

When a vehicle enables Siri Eyes Free mode, the device will not display any onscreen Siri content. If the device was locked at the time the Siri session was activated from the vehicle, it will remain locked and the screen will not turn on. If the user unlocks or manually activates the device while in an Eyes Free Session there will be a notification that the device is in an active Siri session but there will be no visual Siri content displayed.

27.9 Enabling/Disabling Siri from the Device

The user has the ability to disable or enable Siri from the Settings menu on the device. When Siri is disabled, Voice Control becomes the recognition engine on the device and will be triggered by default. The accessory may choose to either launch Voice Control with no further changes, in the same way Siri is launched as in [Figure 27-8](#) (page 110) or display a warning message and not send an activation command to the device as in [Figure 27-9](#) (page 110).

Figure 27-8 Siri is Deactivated - Launching Voice Control

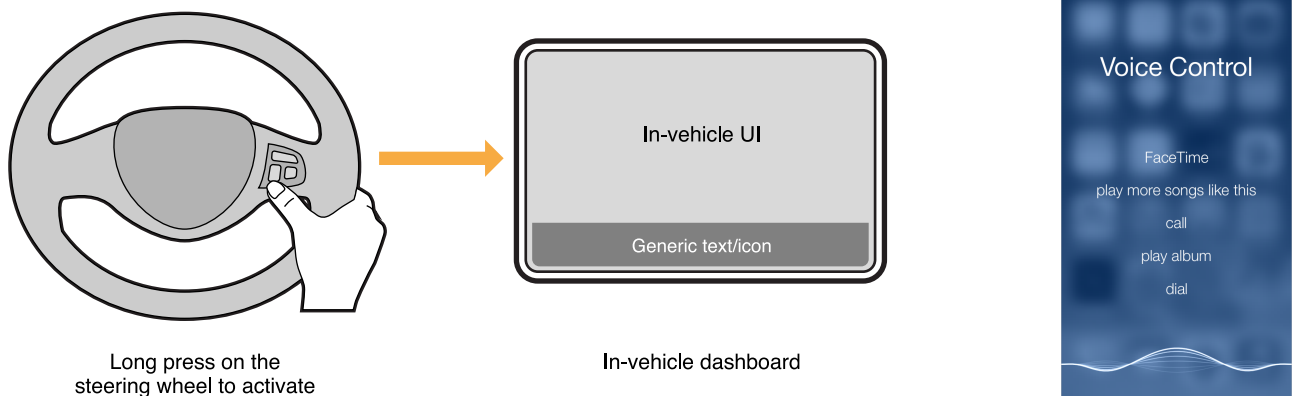
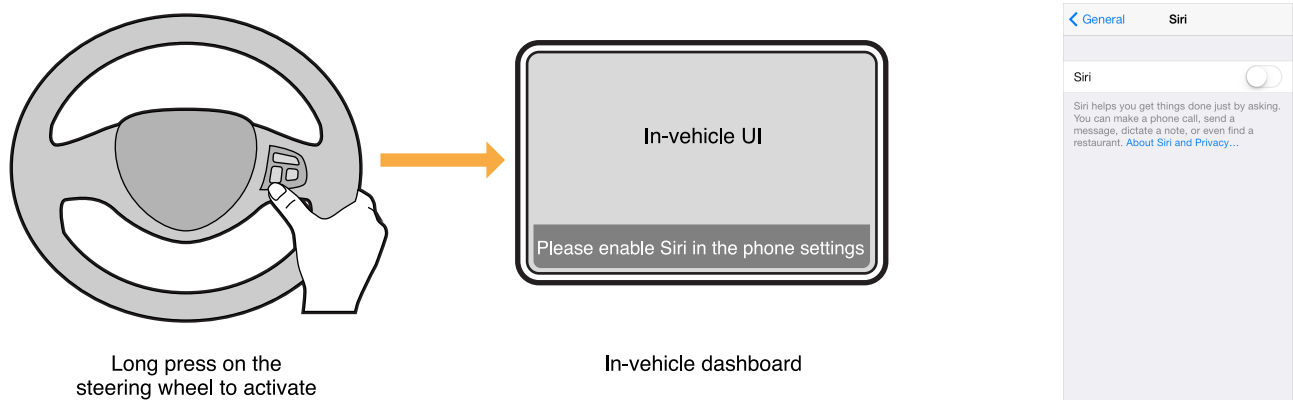

Figure 27-9 Siri is Deactivated - Displaying a Warning Message



27.10 Test Procedures

27.10.1 Siri Eyes Free

The following test procedures are applicable to accessories that interact with Siri Eyes Free.

The speaker should be a native speaker of North American English. If the tester's native language is not North American English, set Siri to the speaker's native language and translate the provided phrases to that language.

27.10.1.1 General

1. Pair and establish a Bluetooth Handsfree Profile (HFP) connection between the iPhone and the head unit. Activate Siri from the vehicle steering wheel button (e.g. by press hold):
 - a. Observe that the iPhone screen remains inactive after a Siri session has started (a visual indicator will be visible on the device if the screen is activated manually).
 - b. Ensure that Siri opening chime is heard completely through the vehicle speakers.
 - c. Observe a visual notification in the in-car User Interface (UI) that a Siri session is active (textual notification, on-screen UI, etc.).
2. Activate Siri from the vehicle steering wheel button and say "Send a message to Peter. How are you?". While still saying the message, press the vehicle steering wheel button to cancel Siri (e.g. by press):
 - a. Ensure the iPhone screen remains inactive (if manually activated, the visual indicator on the phone will disappear).
 - b. Verify that the in-car UI for Siri interaction dismisses and the head unit resumes the state before Siri's interaction.
3. Activate Siri from the vehicle steering wheel button and say "How is the weather in San Francisco?". Wait for Siri to respond with the weather forecast. Once the weather forecast is complete, resume Siri from the vehicle steering wheel button and say "What about New York?":
 - a. Observe that the visual indicator is still active on the phone.
 - b. Listen for the Siri opening chime.
 - c. The vehicle UI should be displaying an on-going Siri session.
 - d. Verify that Siri responds with the weather forecast for New York.
4. In case the vehicle UI offers on-screen controls to activate/cancel/resume Siri, repeat steps (1) to (3) for all on-screen controls.
5. Activate Siri from the steering wheel button and say "What's the time". Listen to the current time and do not interact with Siri or the iPhone. After 5 seconds have expired:
 - a. Observe that the visual indicator on the phone is no longer visible.
 - b. The in-car UI for Siri interaction should be dismissed.
 - c. The head unit should resume the state before Siri's interaction.

6. Listen to FM radio from the car speakers (no A2DP streaming active). Press and hold phone's Home button to activate Siri from the phone:
 - a. Observe a visual notification in the in-car UI that a Siri session is active (textual notification, on-screen UI, etc.).
 - b. Observe Siri's interaction on the phone's screen and ask "What's the time?"
 - c. After Siri has responded, lock the phone again to dismiss the Siri session by pressing the phone's sleep/wake or side button.
7. On the phone go to Settings and turn off Siri. Activate Siri from the head unit. Observe one of the following depending on the actual implementation (a) Voice Control starts instead of Siri (b) The head unit displays a warning that Siri Eyes Free is not available.
8. On the phone go to Settings and turn Siri back on. Verify that Siri can be activated/cancelled from the head unit and from the Home button on the phone.
9. Turn Bluetooth off from the Settings on the phone. Verify that Siri cannot be started.
10. Turn Bluetooth back on from the Settings on the phone. Verify that Bluetooth HFP profile reconnects and that Siri can be activated/cancelled from the head unit and from the Home button on the phone.
11. Make sure there is no accessory battery status level indicator icon displayed on the phone's status bar.

27.10.1.2 Siri Dialog

1. Activate Siri from the vehicle's steering wheel button and say "Send a text message to **insert contact name**". When Siri prompts for "what would you like it to say", dictate a short message. After Siri has read back your dictated message, say "Review it". After Siri has read back the message again, say "Review it" again. Repeat this cycle ~5 times to ensure that the head unit is able to handle a long interaction with Siri. At the end say "Send it" and verify that the message is sent. Verify that the opening chime is audible and the message is sent. After the Siri session is closed, the audio playback should go back to the state it was before Siri was started, i.e. if it was paused remains paused, if it was playing remains playing.
2. Start Siri from the vehicle's steering wheel button and ask for directions. Follow up through the dialog until the navigation is started. Verify that the Siri session is closed and that the audio playback goes back to the state it was before Siri was started, e.g. if it was paused remains paused, if it was playing remains playing.
3. Start Siri from the vehicle's steering wheel button and say "Search the web for polar bears". Verify that Eyes Free mode is on and that this use case is blocked by Siri. Note: In some implementations the vehicle has to be in motion before Eyes Free is activated by the car kit.
4. Start Siri from the vehicle's steering wheel button and say "What is the current time in Munich?". After Siri has answered but before ~5 seconds have elapsed, resume Siri (e.g. by a short press on the steering wheel button) and verify that Siri is initiated again. Say "What about San Francisco?". Repeat (with a different city) and verify that this can continue indefinitely as long as you short press on the steering wheel button within 5 seconds of the last response.

27.10.1.3 Bluetooth HFP A2DP Music

1. Establish a Bluetooth A2DP connection and switch to Bluetooth audio source on the head unit. Activate Siri and ask "Next track". Verify that track advances and that audio is playing through vehicle speakers. Verify that the Siri in-car UI is dismissed and the head unit goes back to its initial state.
2. Activate Siri and say "Pause the music". Verify that audio remains paused after Siri has been dismissed. Verify that the Siri in-car UI is dismissed and the head unit goes back to its initial state.
3. Pause music playback on the head unit (via AVRCP command). Activate Siri and ask "What time is it?". Verify that the music playback remains paused after the Siri session has been dismissed. Verify that the Siri in-car UI is dismissed and the head unit goes back to its initial state.
4. Switch to FM radio on the head unit. Activate Siri and ask "Play me a song". Verify that head unit is able to automatically switch to Bluetooth audio and iPhone music starts playing. Verify that the beginning of the selected track is heard, e.g. there is no skipping of audio packets. Verify that the Siri in-car UI is dismissed and the head unit goes back to its initial state.
5. Activate Siri and ask "Shuffle all songs". Verify that head unit correctly updates NowPlaying track information. Verify that the Siri in-car UI is dismissed and the head unit goes back to its initial state.
6. Activate Siri and ask to play a specific artist or title. Verify that the Siri session is dismissed after the music starts. Make sure the correct metadata is displayed on the screen. Verify that the Siri in-car UI is dismissed and the head unit goes back to its initial state.

27.10.1.4 Call

1. Activate Siri and call a contact with more than one phone number (home and mobile). Wait for Siri's response to ask for which phone number to call. Answer with "home". Verify that call transition is handled correctly by the head unit and any Siri UI displayed on the vehicle screen is dismissed.
2. While iPhone music is playing, activate Siri and say "Call **insert contact name to call**". Verify that call transition is handled correctly by the head unit. Verify that iPhone music playback resumes after the call has been answered and terminated on the far end. Verify that the Siri in-car UI is dismissed and the head unit goes back to its initial state.
3. While iPhone music is playing, start Siri and say "Call **insert contact name to call**". Verify that call transition is handled correctly by the head unit. Verify that iPhone music playback resumes after the call has been answered and terminated on the near end (i.e. on the head unit). Verify that the Siri in-car UI is dismissed and the head unit goes back to its initial state.
4. While in a Siri session, receive an incoming call on the head unit. Verify that head unit handles call-signaling correctly and transitions to phone UI once the call has been accepted. Verify that the Siri in-car UI is dismissed and the head unit goes back to its initial state.

27.10.1.5 Bluetooth + Wired iAP2

1. Connect device to head unit via a Lightning connector (iPhone 5). Switch to iPod music and verify that audio is playing. Activate Siri and say "Next track". Verify that track advances and head unit displays track metadata correctly. Verify that the Siri in-car UI is dismissed and the head unit goes back to its initial state.
2. From the head unit UI, select a playlist with a single song and start playing it. Start Siri from the vehicle steering wheel and say "Play **make sure to select a song to play that is (a) not in the same album as the single-track playlist and (b) not song track index 0 of its album**". Verify that the new song starts playing and that the head unit displays the track metadata for this new song correctly. Verify that the Siri in-car UI is dismissed and the head unit goes back to its initial state.
3. Turn Shuffle off on the head unit UI. Then start Siri and say "Shuffle all songs". Verify that the shuffle indicator on the head unit UI is updated and the correct track metadata for the new now playing song is displayed correctly. Verify that the Siri in-car UI is dismissed and the head unit goes back to its initial state.
4. Switch to FM radio on the head unit. Activate Siri and say "Play me a song". Verify that head unit is able to automatically switch to iPOD audio source and that audio starts playing through the speakers. Verify that there is no skipping of audio at the beginning of the selected track. Verify that the Siri in-car UI is dismissed and the head unit goes back to its initial state.
5. Pause music playback on the head unit (via iAP2 commands). Activate Siri and ask "What time is it?". Verify that music playback remains paused after Siri session has been dismissed. Verify that the Siri in-car UI is dismissed and the head unit goes back to its initial state.
6. While iPhone music is playing, start Siri and say "Call **insert contact name to call**". Verify that call transition is handled correctly by the head unit. Verify that iPhone music playback resumes after the call has been answered and terminated on the far end. Verify that the Siri in-car UI is dismissed and the head unit goes back to its initial state.
7. While iPhone music is playing, start Siri and say "Call **insert contact name to call**". Verify that call transition is handled correctly by the head unit. Verify that iPhone music playback resumes after the call has been answered and terminated on the near end (i.e. on the head unit). Verify that the Siri in-car UI is dismissed and the head unit goes back to its initial state.
8. Pause music playback on the head unit (via iAP2 commands). Start Siri and say "Call **insert contact name to call**". Verify that call transition is handled correctly by the head unit. Verify that iPhone music playback remains paused after the call has been answered and terminated on the far end. Verify that the Siri in-car UI is dismissed and the head unit goes back to its initial state.

28. Wi-Fi Information Sharing

Wi-Fi configuration information can be exchanged between devices and accessories.

Devices can share Wi-Fi configuration information with an accessory. The accessory can initiate this process, but the user shall grant permission for the device to share this information. The device can only share information about the currently connected Wi-Fi network, and this feature will not account for other router-configured access control mechanisms, such as RADIUS or MAC address filtering.

Figure 28-1 Wi-Fi Information Sharing Alert



See the [Accessory Interface Specification](#) (page 16) for more information.

Protocols

29. USB Power Capability Vendor Request

If the accessory is a USB host, and it does not implement [iAP2](#) (page 127), then it may send an Apple-specific USB vendor request to communicate how much power is available to the device. In this case, the accessory shall enumerate and identify the presence of a device, then send the vendor request. The vendor request shall be sent every time the device is enumerated by the accessory.

Table 29-1 USB Vendor Request for non-iAP2 accessory USB Embedded Host

| Field | Value | Comments |
|---------------|---------------|---|
| bmRequestType | 0x40 | Device-to-host request, vendor-defined type, device is recipient. |
| bRequest | 0x40 | Vendor-defined USB get enabled capabilities request. |
| wValue | See comments. | Charging current available, expressed as an offset from 500 mA. Shall be 500 (1000 mA charging current available), 1000 (1500 mA charging current available), 1600 (2100 mA charging current available), 1900 (2400 mA charging current available), or 2500 (3000 mA charging current available). |
| wIndex | See comments. | Shall be the same as wValue. |
| wLength | 0 | 0 bytes expected. |

30. USB D+/D- Resistor Networks

Accessories that do not implement any of the following may use USB resistor networks to identify their current capability:

- [iAP2](#) (page 127).
- [USB Power Capability Vendor Request](#) (page 117).
- [USB-C Current](#) (page 122).
- [USB Power Delivery](#) (page 121).

30.1 Electrical

The accessory shall connect the USB D+ and USB D- pins to resistor networks as shown in [Figure 30-1](#) (page 118).

Figure 30-1 USB D+/D- resistor networks

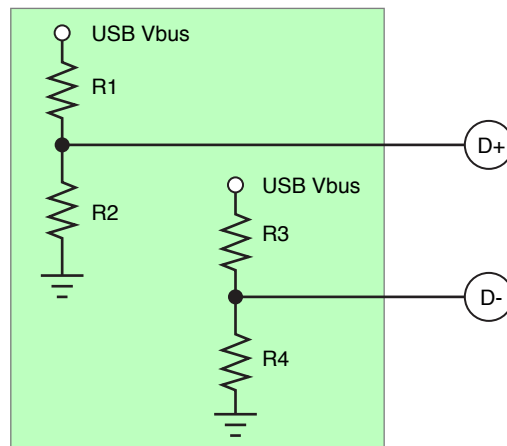

Note: Every iOS device-compatible connector on an accessory that uses a USB resistor network shall have its own set of resistors. The accessory shall be capable of supplying the total current required when all connectors are in use, regardless of whether the connectors are compatible with devices or not.

The resistor network shall be connected at all times unless the accessory uses one of the following methods to enable charging or detect the presence of a device. In these cases, it shall immediately present the resistor network.

- The accessory uses a direct user action to enable charging.
- The accessory senses the attachment of the device via electromechanical means such as a contact switch.

The accessory shall not monitor the USB D+ and USB D- pins to detect the presence of a device.

Note: All resistors used to implement the networks specified in [Figure 30-1](#) (page 118) shall have a tolerance of 1% or better. The resistor network shall not be emulated by driving the voltage of the USB D+/D- pins using some other means.

Table 30-1 USB D+/D- resistor values

| Max Current | R1 | R2 | R3 | R4 |
|-------------|-----------------|-----------------|-----------------|-----------------|
| 3000 mA | 43.2 k Ω | 49.9 k Ω | 24.9 k Ω | 49.9 k Ω |
| 2400 mA | 43.2 k Ω | 49.9 k Ω | 43.2 k Ω | 49.9 k Ω |
| 2100 mA | 43.2 k Ω | 49.9 k Ω | 75.0 k Ω | 49.9 k Ω |
| 1000 mA | 75.0 k Ω | 49.9 k Ω | 43.2 k Ω | 49.9 k Ω |

30.2 Identifying Power Source Current Limit

Accessories shall take into account the variation of USB VBUS voltage and resistor tolerances.

The resistor network values and corresponding current source limit should be identified using the following procedure:

1. Read the VBUS voltage using an ADC. If value is less than 4.5 V, return no resistors detected.
2. Pull-down the D+ and D- lines and read the voltage using an ADC. If either voltage value is less than 1 V, return no resistors detected.
3. Disable the D+ and D- pull-downs and allow the voltage to return to normal.
4. Read the D+ and D- voltages using an ADC (to determine the value for R1 and R3 respectively):
 - If the voltage is >2.995 V (based on 1 M Ω load impedance), then assume a resistor value of 24.9 k Ω .
 - If the voltage is between 2.320 V and 2.995 V (based on 1 M Ω load impedance), then assume a resistor value of 43.2 k Ω .
 - If the voltage is < 2.320 V (based on 1 M Ω load impedance), then assume a resistor value of 75.0 k Ω .
5. Determine the max current based on [Table 30-2](#) (page 120).

30. USB D+/D- Resistor Networks

30.2 Identifying Power Source Current Limit

6. If resistor values could not be identified, proceed to identify the power available based on the *USB Battery Charging 1.2* specification.

Table 30-2 USB D+/D- resistor values

| Max Current | R1 | R2 | R3 | R4 |
|-------------|-----------------|-----------------|-----------------|-----------------|
| 500 mA | 75.0 k Ω | 49.9 k Ω | 75.0 k Ω | 49.9 k Ω |
| 1000 mA | 75.0 k Ω | 49.9 k Ω | 43.2 k Ω | 49.9 k Ω |
| 1000 mA | 75.0 k Ω | 49.9 k Ω | 24.9 k Ω | 49.9 k Ω |
| 2100 mA | 43.2 k Ω | 49.9 k Ω | 75.0 k Ω | 49.9 k Ω |
| 2400 mA | 43.2 k Ω | 49.9 k Ω | 43.2 k Ω | 49.9 k Ω |
| 3000 mA | 43.2 k Ω | 49.9 k Ω | 24.9 k Ω | 49.9 k Ω |
| 1000 mA | 24.9 k Ω | 49.9 k Ω | 75.0 k Ω | 49.9 k Ω |
| 1000 mA | 24.9 k Ω | 49.9 k Ω | 43.2 k Ω | 49.9 k Ω |
| 1000 mA | 24.9 k Ω | 49.9 k Ω | 24.9 k Ω | 49.9 k Ω |

31. USB Power Delivery

Accessories either providing USB Power Delivery (USB-PD) or drawing power from USB-PD sources shall comply with the *USB Power Delivery Specification, Revision 3.0*, version 1.2.

Accessories implementing USB-PD shall incorporate a PD controller that is USB-IF certified with a *Silicon* Test ID from the USB-IF.

Accessories drawing power from USB-PD sources shall correctly identify all sources as defined in the *USB Power Delivery Specification, Revision 3.0*, version 1.2.

Apple recommends the GRL-USB-PD-C2 (see <https://graniteriverlabs.com/usb-pd-c2/>) for USB-PD testing and compliance verification.

32. USB-C Current

Accessories either providing direct power via USB-C Current or drawing power from USB-C Current sources shall comply with the *USB Type-C Cable and Connector Specification Release 1.3*, section 4.6.2.

Apple recommends the GRL-USB-PD-C2 (see <https://graniteriverlabs.com/usb-pd-c2/>) for USB-C Current testing and compliance verification.

33. Advanced Audio Distribution Profile (A2DP)

Accessories may implement the Advanced Audio Distribution Profile (A2DP) over [Bluetooth](#) (page 129) to receive audio from iOS devices and Mac computers.

The audio content from the device can be broadly classified into two categories:

- Audio content from music, video, or gaming applications.
- System-generated sounds for alerts and notifications.

A2DP is often implemented in speakers and headsets.

Accessories that implement A2DP shall satisfy all requirements stated in [Bluetooth](#) (page 129).

33.1 Bluetooth A2DP Specification

Every accessory that implements the Advanced Audio Distribution Profile shall meet the requirements of the Bluetooth *Advanced Audio Distribution Profile* specification, Version 1.2.

33.1.1 AVDTP Transactions

Accessories shall respond to Audio/Video Distribution Transport Protocol (AVDTP) signaling transactions before the device's 5 second RTX_SIG_TIMER expires or the device will terminate the signaling channel. See Section 6.2 "Transaction Model" and section 6.4 "Signal Command Set" of the Bluetooth *Audio/Video Distribution Transport Protocol*, Version 1.3.

33.2 SubBand Codec (SBC)

The SBC Codec Specific Information Elements, defined in Section 4.3.2 of the A2DP specification, that are applicable to iOS devices and Mac computers are listed in [Table 33-1](#) (page 123).

Table 33-1 SubBand Codec Information Elements for iOS devices and Mac computers

| Element | Value |
|--------------------|-----------|
| Sampling Frequency | 44,100 Hz |
| Channel Mode | Stereo |
| Block Length | 16 |

33. Advanced Audio Distribution Profile (A2DP)

33.3 MPEG 2/4 AAC Codecs

| Element | Value |
|-------------------|---|
| Subbands | 8 |
| Allocation Method | Loudness |
| Bitpool range | 2 to 53. Accessories for iOS devices and Mac computers should support 53. |

33.3 MPEG 2/4 AAC Codecs

Devices support the non-mandatory codec MPEG-2/4 AAC, as defined in Section 4.5 of the *Advanced Audio Distribution Profile* specification, Version 1.2. Accessories should use the AAC codec in addition to SBC, because it provides higher audio quality for a given bit rate.

Note: The following specifications provide details of Apple's implementation of the MPEG-2/4 AAC codec. In case of conflicts, the A2DP specification governs.

The MPEG 2/4 AAC Codec Specific Information Elements, defined in Section 4.5 of the A2DP specification, that are applicable to devices are listed in [Table 33-2](#) (page 124).

Table 33-2 MPEG-2/4 AAC Codec Information Elements for devices

| Element | Value |
|--------------------|---------------|
| Object Type | MPEG-2 AAC LC |
| Sampling Frequency | 44,100 Hz |
| Channels | 2 |
| Bit rate | 264,630 bps |
| VBR | 0 |

AAC audio stream packets in devices have the structure shown in [Table 33-3](#) (page 124).

Table 33-3 AAC audio packet for devices

| L2CAP | AVDTP | MPEG-4 LATM | MPEG-4 AAC |
|--------|--------|-----------------|---------------|
| Header | Header | AudioMuxElement | Audio Payload |

The AAC Media Payload Format, as defined in Section 4.5.4 of the A2DP specification, is formatted using LATM, as defined in Section 4 of *IETF RFC 3016*. The following notes apply to the packet fields shown in [Table 33-3](#) (page 124).

- The recommended L2CAP MTU value for each device's AAC streaming channel is 885 bytes.
- The AVDTP Header is shown as the RTP header in Figure 4 of RFC 3016, and is the header defined in Section 7.2.1 of the Bluetooth *Audio/Video Distribution Transport Protocol*, Version 1.2.

- The `AudioMuxElement` is the same as the RTP payload in RFC 3016. It is defined in Section 1.7.3, Table 1.41 in ISO/IEC 14496-3:2009, subpart 1. The `muxConfigPresent` argument to the `AudioMuxElement` is set to 1 (in-band mode), as recommended in Section 4.1 of RFC 3016. As recommended in Section 4.3 of RFC 3016, only one `AudioMuxElement` is put into each AVDTP packet.
- The audio payload is encoded using MPEG-4, as recommended in Section 4.5.4 of the A2DP specification.
- The accessory should support AAC-LC VBR and handle bit rate changes without audio gaps. Devices will vary AAC bit rate depending on the content.

33.4 Test Procedures

33.4.1 Audio Quality

Verify that there are no audio quality issues in each of the following scenarios:

1. Stream music from the Music app.
2. Stream music from a radio station within the Music app.
3. Stream audio using the Podcast app.

33.4.2 Audio Switching

1. During A2DP streaming, switch audio back to device and switch back to accessory.
2. Audio should be routed to the intended source. Audio quality should be good switching back to Bluetooth.

33.4.3 HFP Interaction

1. Make incoming / outgoing call during A2DP.
2. Audio should be suspended during the call and resume after the call.

33.4.4 Siri

1. Trigger Siri during A2DP.
2. Audio should be resumed after the Siri session.

33.4.5 Video Playback

1. Stream A2DP while watching a video.

33. Advanced Audio Distribution Profile (A2DP)

33.4 Test Procedures

2. Audio / video synchronization and quality should be good.

34. iAP2

Accessories may use the iAP2 protocol to access advanced device features. One such feature is the ability to communicate securely with third-party iOS applications via the iOS External Accessory Framework (<http://developer.apple.com/library/ios/#featuredarticles/ExternalAccessoryPT/Introduction/Introduction.html>).

See the [Accessory Interface Specification](#) (page 16) for more information.

Transports

35. Bluetooth

Accessories that integrate Bluetooth technology shall comply with the requirements stated in this chapter.

Every accessory that is compatible with a device shall support the *Bluetooth Core Specification* Version 2.1 + EDR or higher. This specification introduced the important security feature Secure Simple Pairing as well as Extended Inquiry Response.

35.1 Enhanced Data Rate

The Enhanced Data Rate (EDR) feature introduced in the *Bluetooth 2.0* specification enables accessories to communicate more efficiently. Every accessory shall use EDR for the following reasons:

- It provides higher data rates compared to Basic Data Rate (BDR).
- It communicates more efficiently, transferring more data bits per unit of time.
- It reduces the power consumption used per bit transferred.
- It improves coexistence with Wi-Fi and other connected Bluetooth accessories because it frees up more air time.
- It improves performance in multipoint configurations.

35.2 Adaptive Frequency Hopping

The Adaptive Frequency Hopping (AFH) feature introduced in the *Bluetooth 1.2* specification improves coexistence with Wi-Fi and other connected Bluetooth accessories. Every accessory shall use AFH.

35.3 Sniff Mode for Low Power Consumption

Minimizing power consumption is critical for all mobile devices. Therefore, every accessory that is compatible with a device:

- Shall support and should request Bluetooth sniff mode.
- Shall accept requests for sniff mode and support all valid parameters listed in the Bluetooth specification.

- Shall support a sniff interval of 15 ms.
- Should use the following recommended sniff mode values:
 - Max Interval: 15 ms
 - Min Interval: 15 ms
 - Sniff Attempt: 1
 - Sniff Timeout: 0
- Shall not renegotiate sniff after being established.
- Shall support sniff subrating.

Accessories that are compatible with iOS devices and Mac computers should also use sniff mode as much as possible, especially when there is little or no data being transmitted over the Bluetooth link. Besides its power consumption advantages, sniff mode enables better antenna sharing with Wi-Fi.

The sniff mode parameters are specific to the usage model and Bluetooth profile. The device expects the accessory to request sniff mode with appropriate parameters for a specific usage. If the accessory does not send such a request, the device may send a sniff mode request. When the device sends a request for sniff mode, the accessory shall accept the request and its parameters without negotiation.

If the accessory sets the sniff mode parameters, the accessory shall set the sniff interval to less than a third of the Bluetooth baseband [Link Supervision Timeout](#) (page 132). This makes the Bluetooth link less susceptible to interference. To improve link robustness, the accessory should use a shorter sniff interval instead of multiple sniff attempts.

Links with a sniff interval of 1 second or more require a large correlation window, which has to be taken into account when calculating the number of sniff attempts. With sniff intervals shorter than 1 second, multiple sniff attempts can improve link robustness but will increase power consumption.

35.4 Role and Topology Management

Every accessory that is compatible with a device shall:

- Accept a request for Role Switch from a device.
- Continue with the connection when the device rejects a request for Role Switch.

In a Bluetooth connection, there are two entities:

- The Central establishes the common clock and frequency hopping synchronization reference.
- The Peripheral synchronizes with the Central.

The Central can be synchronized with multiple Peripherals, thus forming a piconet. The Central can also be a Peripheral to another Central, creating a scatternet.

A scatternet creates complications since the device has to alternate between the two piconets and thus wastes valuable bandwidth. Managing the topology of the network is therefore important for maximum performance. The device may request a Role Switch, depending on its current topology, and the accessory shall accept the request. The device may also reject a request for a Role Switch because of topology concerns. Having a suboptimal topology may degrade the audio quality and the user's experience.

The accessory should avoid requesting to be the Central as the device will need to be the Central in more frequently occurring scenarios. Accessories that always insist on being the Central may impact the overall user experience.

Accessories that connect to multiple iOS devices or Mac computers simultaneously shall support creating a scatternet.

35.5 Extended Inquiry Response

Every accessory that is compatible with a device shall provide the following information in its Extended Inquiry Response packet:

- The Local Name of the accessory (Complete or Shortened).
- The TX Power Level.

During the Bluetooth discovery process, the device prefers to display the Friendly Name of discovered accessories. Before the 2.1 version of the Bluetooth specification the device would have to set up a connection to the accessory and do a Remote Name Request, which takes power, antenna time, and user's time. The Extended Inquiry Response feature, introduced in Bluetooth 2.1, lets an accessory send its Local Name and other information as part of the Inquiry Response and thereby increase the speed and efficiency of the discovery process.

The Local Name should match the accessory's markings and packaging and not contain ':' or ';'. The accessory may append up to 6 differentiating characters to the Local Name, such as the last few digits of the serial number or MAC address, if a user is likely to encounter more than one of the accessories at the same time.

If the accessory allows the user to customize the Local Name parameter, the accessory should provide a means to restore the factory default name.

35.6 Secure Simple Pairing

Every accessory that is compatible with a device shall:

- Use Secure Simple Pairing.
- Use the Numerical Comparison method if it has a display and input device supporting it.

Secure Simple Pairing greatly increases security and is a mandatory security feature introduced in the Bluetooth 2.1 specification. To protect against a man-in-the-middle attack, the Numerical Comparison association model should be used whenever feasible. See Volume 1, Section 5.4 in the *Bluetooth Core Specification*, Version 2.1 + EDR.

35.7 Pairing Button

If the accessory has a dedicated pairing control surface and it is labeled, it should use official Bluetooth branding. See <https://www.bluetooth.com/marketing-branding/brand-best-practices-guidelines>.

35.8 Class of Device (CoD)

iOS devices and Mac computers use the accessory's Class of Device for UI purposes or to configure specific features.

Every accessory that is compatible with a device shall accurately set its Class of Device using the Bluetooth SIG defined Major Device Class and Minor Device Class. See Volume 3, Part C, Section 3.2.4 in the *Bluetooth Core Specification*, Version 5.0.

For example, an audio/video accessory intended to operate in a vehicle should set Major Device Class to *audio/video* and Minor Device Class to *car-audio*.

35.9 Link Supervision Timeout

The link supervision timeout is used to detect link loss between the accessory and the device.

The accessory shall set the link supervision timeout to 2 seconds or greater when it is the Central to account for the unpredictable nature of RF signals as well as the device's need to service other concurrent wireless systems.

35.10 Delay Reporting

Devices (as of iOS 8.2) support the Delay Reporting commands as specified in the Bluetooth *Audio/Video Distribution Transport Protocol*, Version 1.3. Accessories should provide this information as it is used to improve audio/video synchronization for video playback. Accessories should not report a delay of more than 1000 ms and should not update the delay more than 1 time per second.

35.11 Profiles

The Apple knowledge base article <https://support.apple.com/kb/ht3647> provides a complete list of the Bluetooth profiles that certain devices support. The Bluetooth specifications are the starting point for designing accessories that are compatible with these products. The following sections add information and requirements for some profiles, which can help accessory developers achieve superior results.

35.11.1 Device ID Profile (DID)

Every accessory that is compatible with a device shall:

- Support the Bluetooth Device ID Profile, version 1.3 or higher.
- Use the company identifier from the Assigned Numbers specification assigned by the Bluetooth SIG as its Vendor ID value (VID). See <http://www.bluetooth.org/Technical/AssignedNumbers/identifiers.htm> (requires login). Bluetooth HID Profile accessories may use a VID assigned by the USB Implementers Forum (USB-IF at <http://www.usb.org>) if the manufacturer does not have a Bluetooth SIG company identifier.
- Use its VID value for the end product manufacturer.
- Not use the Company ID assigned to Apple by the Bluetooth SIG or the Vendor ID assigned to Apple by the USB Implementers Forum.
- Use the Vendor ID Source field to identify which organization assigned the value used in Vendor ID field value. See Section 5.6 of the *Bluetooth Device ID Profile Specification*.
- Use a ProductID value that uniquely identifies the product.
- Use a Version value that uniquely identifies the software version.

The Device ID record lets the device identify the implementation of the remote accessory. This is valuable information and can be used to bridge alternate interpretations of the Bluetooth specification when communicating with a remote accessory. Therefore it is important that the information in the Device ID record uniquely identify the implementation.

In the case of Bluetooth car kit devices, the same car kit might go into two different car models. Ideally the two car kits should have different ProductIDs. However, it is acceptable for them to have the same ProductID as long as they have identical hardware, software, and features. If the implementations differ at all, they should have different ProductIDs. The accessory can also use a secondary Device ID record to uniquely identify the product ID or model number.

35.11.2 Service Discovery Protocol (SDP)

To facilitate caching of Service Discovery Protocol (SDP) service records, every accessory that is compatible with a device shall:

- Support the ServiceDiscoveryServer Service Class.
- Support the ServiceDatabaseState attribute.
 - The attribute's value shall change whenever any SDP service record or attributes within a record are added, removed, or modified.
 - The attribute's value shall not change based on RFCOMM channel protocol parameters since devices query these values separately at connection time.

35.11.3 Hands-Free Profile (HFP)

Every accessory that is compatible with a device and supports the Handsfree Profile should meet the requirements of the *Bluetooth Hands-Free Profile Specification*, Version 1.5 or higher. Additional Apple requirements are specified in this section.

Remote accessories can use the Bluetooth *Hands-Free Profile* for phone communications. To achieve the best user experience, the remote accessory should support the following features, which are optional in the Bluetooth specification.

35.11.3.1 Remote Audio Volume Control

Every accessory that is compatible with a device and supports HFP should:

- Support Remote Audio Volume Control so the speaker volume on the Hands-Free accessory can be controlled from the device as described in Section 4.28 in the *Bluetooth Hands-Free Profile Specification* version 1.5.
- Set the Remote volume control bit in the Supported Features bitmap sent with the AT+BRSF= command.

In some situations it is easier for the user to control the output volume through the device instead of directly on the remote accessory. For example, a passenger (or-if the car is parked-the driver) in a car could use the volume slider on the phone to control the audio volume. Volume control synchronization is outlined in Section 4.48.2 in the *Bluetooth Hands-Free Profile Specification* version 1.5.

35.11.3.2 Indicator Event Reporting

Every accessory that is compatible with a device and supports HFP should use indicator events reporting and not perform repetitive polling of status.

iOS devices and Mac computers support all mandatory and optional indicators specified in HFP version 1.5 (service, call, callsetup, callheld, signal, roam, battchg). To minimize unnecessary polling of status using the AT+CIND? command, the remote accessory should enable indicator events reporting by sending an AT+CMER command. The device will then send a +CIEV event when there is a change in status of an indicator. The remote accessory should request the initial status using the AT+CIND=? and AT+CIND? commands, according to the HFP specification.

35.11.3.3 Voice Recognition Activation

Every accessory that is compatible with a device and supports HFP shall:

- Support Voice Recognition Activation, both AG and HF initiated as described in Section 4.25 in the *Bluetooth Hands-Free Profile Specification* version 1.5.
- Set the Voice Recognition Activation bit in the "SupportedFeatures" bitmap sent with the AT+BRSF= command.

iOS devices and Mac computers support voice recognition initiated by remote (Hands-Free) accessories and iOS (Audio Gateway) accessories.

35.11.3.4 Echo Cancellation and Noise Reduction

When echo cancellation and noise reduction are performed locally on a Hands-Free accessory, it should turn off echo cancellation and noise reduction on the device by sending an AT+NREC command, as described in Section 4.24 in the *Bluetooth Hands-Free Profile Specification* version 1.5.

iOS devices and Mac computers support echo cancellation and noise reduction; these features are active by default. If a Hands-Free accessory also does echo cancellation and noise reduction it needs to turn these features off on the device (the Audio Gateway). This avoids unnecessary degradation of audio quality due to double audio processing.

35.11.3.5 In-Band Ringing

Every accessory that is compatible with a device and supports HFP should also support In-Band Ringing as specified in Section 4.13.1 in the *Bluetooth Hands-Free Profile Specification* version 1.5. If the user sets a ring tone on the device, the same ring tone should sound on the hands-free accessory.

35.11.3.6 Synchronous Connection

Every accessory that is compatible with a device and supports HFP shall:

- Support eSCO parameter set S2 and S3 and accept requests for these settings. See Section 5.6 of the *Bluetooth Hands-Free Profile Specification* version 1.5.
- Request eSCO parameter set S2 or S3 when setting up a Synchronous Connection. Note that eSCO parameter set S1 should not be requested.
- Render audio within 40 ms after the SCO/eSCO connection has been set up.

The eSCO packet types offers retransmission of packets; traditional SCO packets are not retransmitted. This improves audio quality and the user's experience. The eSCO packet types 2-EV3 and 3-EV3 offer a greater time interval between packets, which can improve Wi-Fi performance and allow time for other concurrent Bluetooth connections to send data. Apple strongly recommends the use of 2-EV3 and 3-EV3 packets for SCO connections. Using HV3 packets is highly discouraged. HV3 packets require more link time and does not allow for retransmission of audio packets which impacts the audio performance in presence of RF interference.

35.11.3.7 Wide Band Speech

Every accessory that is compatible with a device and supports HFP should support Wide Band Speech as described in Section 5.7.4 of the *Bluetooth Hands-Free Profile* specification version 1.6. If Wide Band Speech is supported, it should support the T2 link parameter settings.

All devices running iOS 5 or later support Wide Band Speech. If both the device and the accessory support Wide Band Speech then Wide Band Speech link will be used for eSCO connection for use cases like cellular calls, FaceTime and Siri.

35.11.4 Message Access Profile (MAP)

Every accessory that is compatible with a device and supports the Message Access Profile shall:

- Support Message Notification as described in Section 4.1 of the *Bluetooth Message Access Profile Specification*, version 1.1.
- Register for notifications immediately after the connection is established, as described in Section 4.5 in the *Message Access Profile Specification*, version 1.1.

All devices running iOS 13.0 or later support MAP 1.1.

35.11.5 Audio/Video Remote Control Profile (AVRCP)

Every accessory that is compatible with a device and supports the Audio/Video Remote Control Profile should meet the requirements of the *Bluetooth Audio/Video Remote Control Profile Specification*, Version 1.4. Additional Apple requirements are specified in this section.

35.11.5.1 Supported Operations

iOS devices and Mac computers support the following operation_IDs in passthrough commands:

- Play
- Stop
- Pause
- Fast Forward
- Rewind
- Forward
- Backward

35.11.5.2 Repeat and Shuffle Modes

Every device supports Repeat and Shuffle modes in the role of an AVRCP target. An AVRCP controller may use `SetPlayerApplicationSettingValue` to set a value on the device and `GetPlayerApplicationSettingValue` to read a value, as described in Sections 6.5.4 and 6.4.3 of the *Bluetooth Audio/Video Remote Control Profile Specification* version 1.4.

35.11.5.3 Notifications

Every accessory that is compatible with a device and supports AVRCP should register for notifications and not perform repetitive polling to determine the status of the device.

Every device supports registering for notifications in the role of an AVRCP Target, as described in Section 6.7 of the *Bluetooth Audio/Video Remote Control Profile Specification* version 1.4. The commands `RegisterNotification` and `GetPlayStatus` are supported for these notifications:

- `EVENT_PLAYBACK_STATUS_CHANGED`
- `EVENT_TRACK_CHANGED`
- `EVENT_NOW_PLAYING_CONTENT_CHANGED`
- `EVENT_AVAILABLE_PLAYERS_CHANGED`
- `EVENT_ADDRESSED_PLAYER_CHANGED`
- `EVENT_VOLUME_CHANGED`

35.11.5.4 Play/Pause Button

All accessories that support AVRCP and implement a Play/Pause control surface shall confirm the playback status of the device via AVRCP [Notifications](#) (page 137) before sending a Play or Pause command, see [Supported Operations](#) (page 137). Specifically:

- If the device has notified the accessory that it is paused, pressing the accessory's Play/Pause control surface should send a Play command.

- If the device has notified the accessory that it is playing, pressing the accessory's Play/Pause control surface should send a Pause command.
- The accessory should not infer device playback status based on the number of times the Play/Pause control surface has been pressed.

35.11.5.5 Volume Handling

Every accessory that is compatible with a device and supports AVRCP should support Absolute Volume, as described in Section 6.13 of the *Bluetooth Audio/Video Remote Control Profile Specification* version 1.4.

Every device supports volume handling in the role of AVRCP Controller.

35.11.5.6 Browsing

Every accessory that is compatible with a device and supports Browsing (in controller role) as part of AVRCP shall:

- Not try to index or cache the entire library upon connection. The device may contain tens of thousands of media items, each present multiple times in the hierarchy.
- When browsing a specific folder, do not fetch all its items. Only fetch those that are displayed to the user. It may prefetch a few items to improve the responsiveness of the user interface.
- Not reorder items (e.g. alphabetically).
- Not assume UIDs to be statically defined, especially in the root folder. The ordering and UIDs of folders and items may change at any point in future releases.
- Send the `SetBrowsedPlayer` command after receiving an `EVENT_UIDS_CHANGED` notification.
- Not assume that the UID passed to the `PlayItem` command will result in the media player playing that UID.

Currently only the built-in Music app supports browsing. When switching between players, an `EVENT_AVAILABLE_PLAYERS_CHANGED` notification and an `EVENT_ADDRESSED_PLAYER_CHANGED` notification will be generated. The UI then needs to look at the feature bit mask of the listed player to determine whether browsing is currently available.

All devices running iOS 6.0 or later support AVRCP Browsing.

35.11.5.7 iOS App-Provided Metadata

An audio app running on a device may use the iOS Media Player Framework to provide metadata about the current audio stream. The device supplies this metadata to the accessory using AVRCP. Requirements and usage for these messages may be found in the `MPNowPlayingInfoCenter` class in Apple Media Player Framework documentation.

35.11.6 Advanced Audio Distribution Profile (A2DP)

See [Advanced Audio Distribution Profile \(A2DP\)](#) (page 123).

35.12 Audio Routing

This section describes how an accessory can differentiate between various audio contents coming from a device and use this information to decide playback behavior.

An accessory can receive audio data from the device via either of two Bluetooth profiles:

- HFP using eSCO channel
- A2DP using ACL channel

The device picks which channel to use depending on how the audio content is used. An audio path created for two way communication (such as phone calls or FaceTime) always uses the HFP (eSCO) route for sending audio data. Music and similar content uses the A2DP route. In the absence of a defined route, audio playback will default to the device.

35.12.1 Audio Data Received via HFP Profile

Most of the audio content sent via HFP (eSCO) routes requires two way communication. Cases where HFP (eSCO) is used include (but are not limited to) cellular calls, FaceTime, and voice mail.

The accessory speaker and microphone should be dedicated to the HFP (eSCO) route and not mixed/muxed with any other audio sources.

35.12.2 Audio Data Received via A2DP Profile

Audio content transferred via A2DP profiles can be broadly classified into two categories:

- Audio content from music, video, or game-like applications.
- System-generated sound for alerts and notifications.

35.12.2.1 Differentiating Audio Content from System Sounds

Music-like content can be differentiated from system sound by adding support for Audio/Video Remote Control Profile (AVRCP) version 1.3 or later. The AVRCP profile allows an accessory to be aware of the audio playback state in the device, using notifications. See [Audio/Video Remote Control Profile \(AVRCP\)](#) (page 136).

When a device initiates audio playback over an A2DP channel for playing music content, an AVRCP notification `EVENT_PLAYBACK_STATUS_CHANGED` is sent to indicate that playback status has changed to play state. See Section 6.7.2 of the *Audio/Video Remote Control Profile* specification, version 1.4. This indicates that audio data via the A2DP profile contains music. When a device initiates audio playback over an A2DP channel for playing system sound, no AVRCP notification is sent.

Figure 35-1 (page 140) and Figure 35-2 (page 140) show the difference between the notifications for music playback and for system sounds.

Figure 35-1 Initiate Audio Playback (e.g. music)

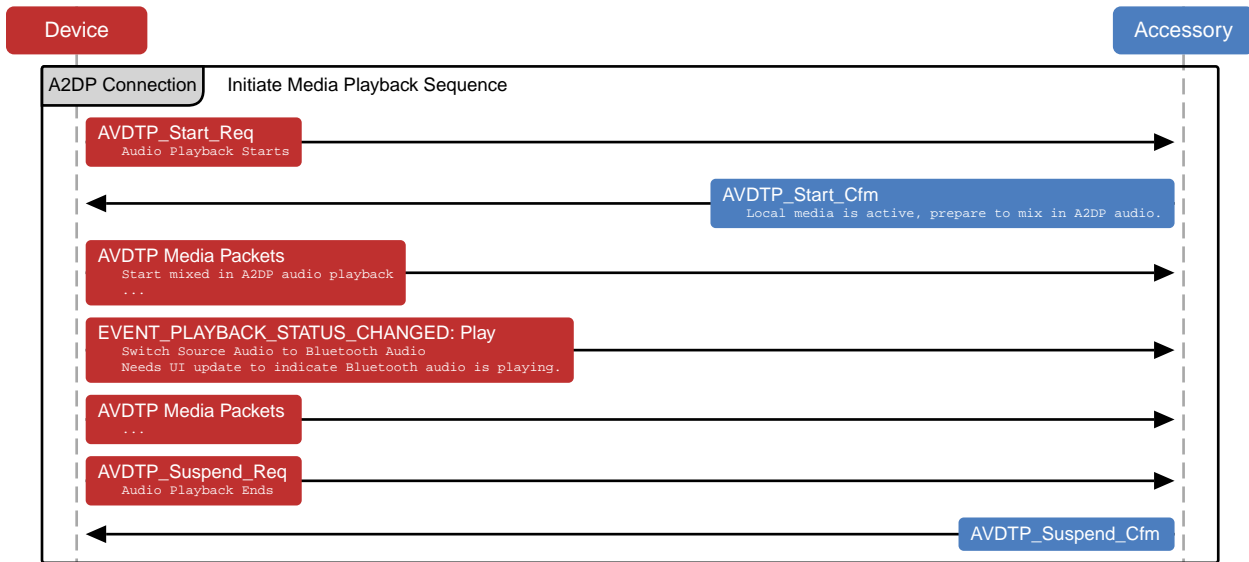
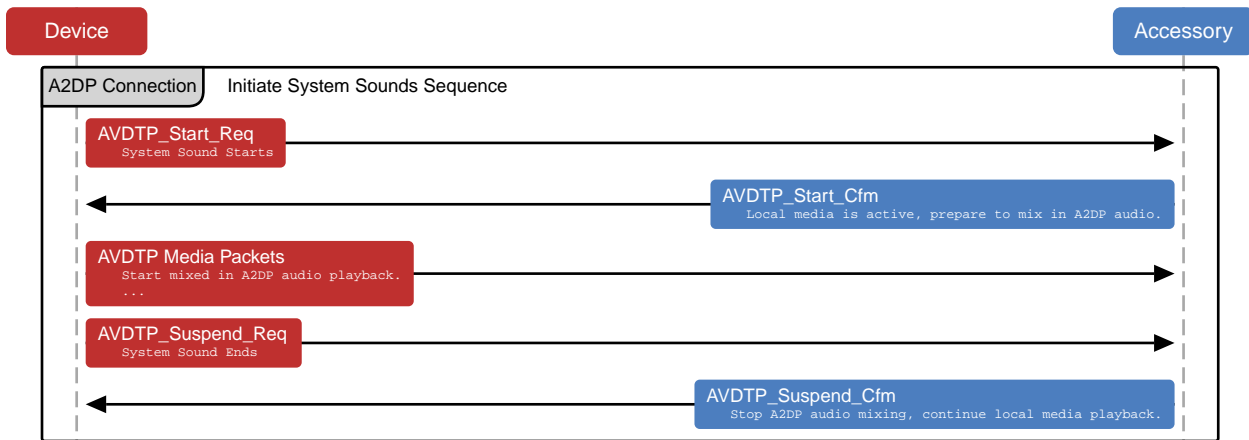

Figure 35-2 Initiate System Sound (e.g. turn-by-turn directions)



35.12.2.2 Expected Audio Routing Behavior for A2DP

The accessory should tune its audio routing behavior based on audio content over the A2DP channel.

If audio data contains music, then it is expected that the accessory speakers are dedicated to audio data coming via the Bluetooth link and any other audio playback is paused. If audio data contains system sound, then it is expected that the accessory can render audio as desired. If the accessory is playing audio from a different source, then system sound data can be mixed with the existing track for playback; it is not necessary to pause existing audio playback on the device.

35.13 HID

When implementing HID over Bluetooth, the accessory:

- Should support Bluetooth HID Profile 1.1.
- Should support [Sniff Mode for Low Power Consumption](#) (page 129).
- Should use the following parameters in SDP for sniff subrating:
 - HIDSSRHostMaxLatency - 450 ms (720 slots)
 - HIDSSRHostMinTimeout - 45 ms (72 slots)
- Should use a typical report packet of 22 bytes or less. This is small enough to fit into a DH1 packet with L2CAP and HID header.

36. Bluetooth Low Energy (BLE)

The *Bluetooth 4.0* specification introduces Bluetooth Low Energy (BLE), a wireless technology targeted for accessories with limited battery resources. If Bluetooth Low Energy is supported, the accessory should follow the guidelines in this section.

36.1 Role

The accessory should implement either the Peripheral role as defined in the *Bluetooth 4.0* specification, Volume 3, Part C, Section 2.2.2.3 or the Broadcaster role, as defined in Section 2.2.2.1.

36.2 Advertising Channels

The accessory should advertise on all three advertising channels (37, 38, and 39) at each advertising event. See the *Bluetooth 4.0* specification, Volume 6, Part B, Section 4.4.2.1.

36.3 Advertising PDU

The accessory should use one of the following advertising PDUs:

- ADV_IND
- ADV_NOCONN_IND
- ADV_SCAN_IND

ADV_DIRECT_IND should not be used. See the *Bluetooth 4.0* specification, Volume 6, Part B, Section 2.3.1.

36.4 Advertising Data

The advertising data sent by the accessory should contain at least the following information as described in the *Bluetooth Core Specification Supplement*, Part A:

- Flags

- TX Power Level
- Local Name
- Services

The Local Name should match the accessory's markings and packaging and not contain ':' or ';'.

The accessory may put the Local Name and the TX Power Level data in the SCAN_RSP PDU if, for example, it needs to reduce power consumption or not all of the advertising data fit into the advertising PDU. Note that, depending on its state, the device may not always perform active scanning.

The primary services should always be advertised in the advertising PDU. Secondary services should not be advertised. Services not significant to the primary use case of the accessory may be omitted if space is limited in the Advertising PDU.

The advertising data and the scan response data in the SCAN_RSP PDU should comply with the formatting guidelines in the *Bluetooth 4.0* specification, Volume 3, Part C, Section 18: it starts with a length field, followed by AD Type and AD Data.

36.5 Advertising Interval

The accessory should first use the recommended advertising interval of 20 ms for at least 30 seconds.

If it is not discovered within the initial 30 seconds, Apple recommends using one of the following longer intervals to increase chances of discovery by the device:

- 152.5 ms
- 211.25 ms
- 318.75 ms
- 417.5 ms
- 546.25 ms
- 760 ms
- 852.5 ms
- 1022.5 ms
- 1285 ms

Note: Longer advertising intervals usually result in longer discovery and connect times, but may lower accessory power consumption.

36.6 Connection Parameters

The accessory is responsible for the connection parameters used for the Low Energy connection. The accessory should request connection parameters appropriate for its use case by sending an L2CAP Connection Parameter Update Request at the appropriate time. See the *Bluetooth 4.0* specification, Volume 3, Part A, Section 4.20 for details.

The connection parameter request may be rejected if it does not comply with all of these rules:

- Peripheral Latency ≤ 30
- $2 \text{ seconds} \leq \text{connSupervisionTimeout} \leq 6 \text{ seconds}$
- Interval Min modulo 15 ms == 0
- Interval Min $\geq 15 \text{ ms}$
- One of the following:
 - Interval Min + 15 ms \leq Interval Max
 - Interval Min == Interval Max == 15 ms
- Interval Max * (Peripheral Latency + 1) $\leq 2 \text{ seconds}$
- Interval Max * (Peripheral Latency + 1) * 3 < connSupervisionTimeout

Note that if an accessory requests Interval Min == Interval Max == 15 ms, some devices will scale the interval to 30 ms to balance power and performance constraints.

If Bluetooth Low Energy HID is one of the connected services of an accessory, connection interval down to 11.25 ms may be accepted by the device.

The device will not read or use the parameters in the Peripheral Preferred Connection Parameters characteristic. See the *Bluetooth 4.0* specification, Volume 3, Part C, Section 12.5.

36.7 Data Packet Length Extension

Data Packet Length Extension is an enhancement introduced in the *Bluetooth 4.2* specification which increases the maximum data length from 27 to 251. Using a longer per-packet data length improves radio efficiency, greatly increases application data rates, and boosts battery life. See the *Bluetooth 5.0* specification, Volume 6, Part B, Section 4.6.6 for details.

Figure 36-1 Data Packet Length Extension

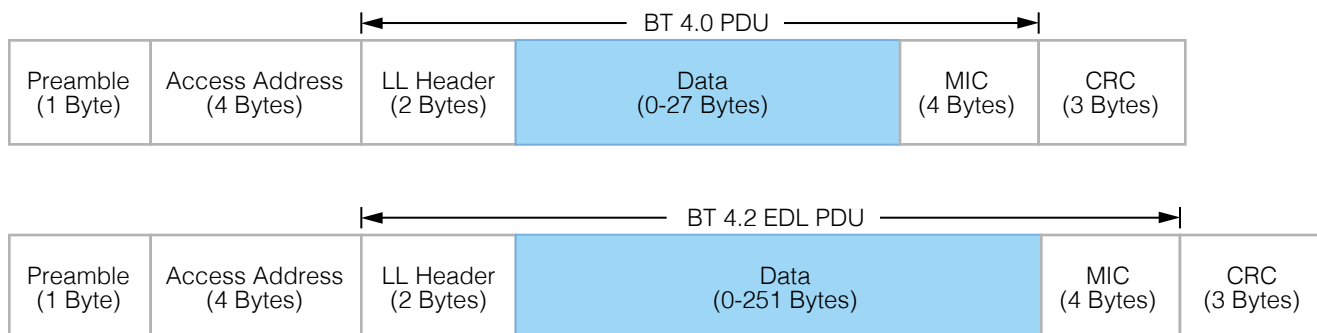

Accessories should support Data Packet Length Extension for best performance with devices.

iOS devices and Mac computers operating as the Central will negotiate optimal data packet lengths based on various factors, such as connection event length, system topology, and protocol.

36.8 Privacy

The accessory should be able to resolve a Resolvable Private Address in all situations. Due to privacy concerns, the device will use a Random Device Address as defined in the *Bluetooth 4.0* specification, Volume 3, Part C, Section 10.8.

36.9 Permissions

The accessory should not require special permissions, such as pairing, authentication, or encryption to discover services and characteristics. It may require special permissions only for access to a characteristic value or a descriptor value. See the *Bluetooth 4.0* specification, Volume 3, Part G, Section 8.1, fifth paragraph.

36.10 Pairing

The accessory should not request pairing until an ATT request is rejected using the Insufficient Authentication error code. See the *Bluetooth 4.0* specification, Volume 3, Part F, Section 4 for details.

If, for security reasons, the accessory requires a bonded relationship with the Central, the Peripheral should reject the ATT request using the Insufficient Authentication error code, as appropriate. As a result, the device may proceed with the necessary security procedures.

Similarly, if the device acts as a Central and a GATT server, it may reject an ATT request using the Insufficient Authentication error code. The accessory should initiate the security procedure for pairing in response.

Pairing may require user authorization depending on device. Once an accessory is paired with a device, it shall retain the distributed keys of both central and peripheral for future use. If the pairing is no longer required, the accessory shall delete both sets of keys.

36.11 MTU Size

An accessory that supports packet length extension shall perform the packet length update procedure before performing the Exchange MTU Request handshake, see [Data Packet Length Extension](#) (page 144).

Devices will support and request an MTU size larger than the default during the Exchange MTU Request handshake. See the *Bluetooth 4.0* specification, Volume 3, Part F, Section 3.2.8.

When operating as ATT client, the device will request the optimal MTU size based on factors such as the Bluetooth topology, connection event length, maximum data length, and protocol (GATT or connection-oriented L2CAP).

An accessory operating as ATT server should select an MTU that is equal to or greater than the device's MTU request.

36.12 Services

36.12.1 Generic Access Profile Service

The accessory should implement the Device Name characteristic per the *Bluetooth 4.0* specification, Volume 3, Part C, Section 12.1. The Device Name characteristic should be writeable.

36.12.2 Generic Attribute Profile Service

The accessory shall implement the Service Changed characteristic only if the accessory has the ability to change its services during its lifetime.

The device may use the Service Changed characteristic to determine if it can rely on previously read (cached) information from the device. See the *Bluetooth 4.0* specification, Volume 3, Part G, Section 7.1.

36.12.3 Device Information Service

The accessory shall implement the Device Information Service. The service UUID for this service should not be advertised in the Advertising Data. The following characteristics should be supported:

- Manufacturer Name String
- Model Number String
- Firmware Revision String
- Software Revision String

36.12.4 Available Services

With iOS 7.0, any device makes Battery Service, Current Time Service and Apple Notification Center Service (ANCS) available to an accessory. The Current Time Service supports the current time and local time information characteristics. The service does not provide an "Adjust Reason" when the current time changes. ANCS uses 7905F431-B5CE-4E99-A40F-4B1E122D00D0 as its UUID.

These services are not guaranteed to be available immediately after connection and the accessory shall support Characteristic Value Indication of the Service Changed characteristic (see *Bluetooth 4.0* specification, Volume 3, Part G, Section 7.1) to be notified when the services become available. The device will maintain a connection to an accessory as long as it is paired and uses one of the available services.

36.13 GATT Server

With iOS 6.0, applications may contribute services and characteristics to the GATT server that the device makes available to the accessory. The recommendations in this section apply to the accessory in this case.

The following services are implemented internally by iOS and shall not be published by third party iOS applications:

- Generic Attribute Profile Service
- Generic Access Profile Service
- Bluetooth Low Energy HID Service
- Battery Service
- Current Time Service
- Apple Notification Center Service

The device implements the GAP Service Changed characteristic, because the database contents can change at any time. The accessory should therefore support the Characteristic Value Indication of this characteristic and, upon receiving indications, invalidate its database cache accordingly. See the *Bluetooth 4.0* specification, Volume 3, Part G, Section 7.1.

The accessory should minimize the use of ATT/GATT requests and commands and only send what is necessary. For example, do not use GATT Discover All Services when the accessory is looking for specific services. Use Discover Primary Service By Service UUID instead. Less airtime equals less power consumption and better performance for both the accessory and the device.

When third party iOS applications discover services on the accessory, the following services are used internally by iOS and are filtered out from the list of discovered services:

- Generic Attribute Profile Service
- Generic Access Profile Service
- Bluetooth Low Energy HID Service
- Apple Notification Center Service

The accessory should be robust enough to handle any error gracefully. Pairing and Characteristic Value reads/writes may fail if the application that owns the service is not in the foreground and is not entitled to run in the background.

If an ATT Prepare Write Request is used, all queued attributes are contained within the same GATT Service.

Connectors

37. USB-A Receptacle

Accessories may incorporate a USB-A receptacle to:

- Provide power to a device.

37.1 Mechanical

The USB-A receptacle shall meet or exceed all applicable USB-IF mechanical specifications.

37.2 Electrical

The USB-A receptacle shall meet or exceed all applicable USB-IF electrical specifications.

38. USB-C Plug

Accessories may incorporate a USB-C plug to:

- Draw power from Apple branded or MFi certified USB power sources.
- Draw power from USB-C Current sources.
- Draw power from USB Power Delivery sources.
- Draw power from USB Dedicated Charging Ports and USB hosts, such as a Mac.
- Enable USB connection to a Mac.

Examples of accessories that may benefit from including a USB-C plug include cables, battery packs, and adapters.

38.1 Mechanical

The USB-C plug shall have an assigned *Connector* Test ID from the USB-IF.

38.2 Electrical

Accessories shall not directly electrically connect a USB-C plug to the device.

Accessories that draw power from the USB-C plug shall:

- Correctly identify all Apple branded or MFi certified USB power sources that use [USB D+/D- Resistor Networks](#) (page 118).
- Correctly identify all USB Dedicated Charging Ports (DCP) as defined in the *USB Battery Charging 1.2* specification.
- Correctly identify all [USB-C Current](#) (page 122) sources.
- Enumerate as a USB device when connected to a USB host, such as a Mac, and:
 - Not draw more than 100 mA of current until they have been successfully enumerated.
 - Request no more than 500 mA of charging current in their USB device descriptor.
- Not draw more power than the USB power source claims it is capable of providing via one of the above methods.

Accessories may also correctly identify all [USB Power Delivery](#) (page 121) sources.

38.3 Test Procedures

38.3.1 Connector Test ID

Verify that the accessory's USB-C plug has an assigned *Connector* Test ID from the USB-IF.

38.3.2 Drawing Power

This procedure applies to accessories that draw power via the USB-C plug.

The following equipment is needed:

- Apple 29W USB-C Power Adapter
- Bundled USB-C power adapter (if applicable)

Verify that the accessory correctly identifies all Apple branded or bundled power sources:

1. Verify that each USB-C power adapter is correctly identified and provides power.

Verify that the accessory correctly identifies a Mac:

1. Verify that the Mac is correctly identified and provides power.

39. USB-C Receptacle

Accessories may incorporate a USB-C receptacle to:

- Provide power to a device.
- Draw power from Apple branded or MFi certified USB power sources.
- Draw power from USB-C Current sources.
- Draw power from USB Power Delivery sources.
- Draw power from USB Dedicated Charging Ports and USB hosts, such as a Mac.
- Enable USB connection to a Mac.

Accessories shall not integrate a USB-C receptacle to enable passthrough USB charge/sync of a device.

Examples of accessories that may benefit from including a USB-C receptacle include [AC Power Adapters](#) (page 55), [Battery Packs](#) (page 58), and speakers.

39.1 Mechanical

The USB-C receptacle shall be USB-IF certified and have a *Connector* Test ID from the USB-IF.

39.2 Electrical

Accessories shall not directly electrically connect a USB-C receptacle to the device.

39.2.1 Drawing Power

Accessories that draw power from the USB-C receptacle shall:

- Correctly identify all Apple branded or MFi certified USB power sources that use [USB D+/D- Resistor Networks](#) (page 118).
- Correctly identify all USB Dedicated Charging Ports (DCP) as defined in the *USB Battery Charging 1.2* specification.
- Correctly identify all [USB-C Current](#) (page 122) sources.
- Enumerate as a USB device when connected to a USB host, such as a Mac, and:
 - Not draw more than 100 mA of current until they have been successfully enumerated.
 - Request no more than 500 mA of charging current in their USB device descriptor.

- Not draw more power than the USB power source claims it is capable of providing via one of the above methods.

Accessories may also correctly identify all [USB Power Delivery](#) (page 121) sources.

39.2.2 Providing Power

Accessories that provide power to a device via a USB-C receptacle:

- Shall provide at least 15 W (3 A at 5.0 V) of power.
- Shall support [USB-C Current](#) (page 122).
- Should support [USB Power Delivery](#) (page 121).
- Should label the receptacle indicating how much power is supplied in watts.

39.3 Test Procedures

39.3.1 Connector Test ID

Verify that the accessory's USB-C receptacle has an assigned *Connector* Test ID from the USB-IF.

39.3.2 Drawing Power

This procedure applies to accessories that draw power via the USB-C receptacle.

The following equipment is needed:

- Apple USB-C Charge Cable (1 m)
- Apple USB-C Charge Cable (2 m)
- Bundled USB-C to USB-C cable (if applicable)
- Bundled USB-A to USB-C cable (if applicable)
- 3rd-party USB-A to USB-C cable
- Apple 5W USB Power Adapter
- Apple 10W USB Power Adapter
- Apple 18W USB Power Adapter
- Apple 12W USB Power Adapter
- Apple 29W USB-C Power Adapter
- Apple 30W USB-C Power Adapter
- Bundled USB-C power adapter (if applicable)
- Bundled USB-A power adapter (if applicable)
- MFi USB-C power adapter(s)

- MFi USB-A power adapter(s)

Verify that the accessory correctly identifies all Apple branded or bundled power adapters:

1. Using each USB-A to USB-C cable, verify that each USB-A power adapter is correctly identified and provides power.
2. Using each USB-C to USB-C cable, verify that each USB-C power adapter is correctly identified and provides power.

Verify that the accessory correctly identifies a Mac:

1. Using each USB-A to USB-C cable and USB-C to USB-C cable, verify that the Mac is correctly identified and provides power.

Verify that the accessory correctly identifies MFi power adapters:

1. Using each USB-A to USB-C cable, verify that each MFi USB-A power adapter is correctly identified and provides power.
2. Using each USB-C to USB-C cable, verify that each MFi USB-C power adapter is correctly identified and provides power.

39.3.3 Providing Power

This procedure applies to accessories that provide power via the USB-C receptacle.

The following equipment is needed:

- Apple USB-C to Lightning Cable (1 m)
- Apple USB-C to Lightning Cable (2 m)
- Apple USB-C Charge Cable (1 m)
- Apple USB-C Charge Cable (2 m)
- Bundled USB-C to USB-C cable (if applicable)

Verify that the accessory correctly provides power to devices:

1. Using each USB-C to Lightning cable, verify that the accessory uses USB-C Current or USB-PD to identify at least 15 W of power providing capability.
2. Using each USB-C to Lightning cable, verify that the accessory provides power to the device.

Verify that the accessory correctly identifies a Mac:

1. Using each USB-C to USB-C cable, verify that the accessory is correctly identified and provides power to the Mac.

References

40. Device Dimensional Drawings

This chapter contains the following dimensional drawings:

- [iPhone 12 Pro Max 1 of 2](#) (page 161)
- [iPhone 12 Pro Max 2 of 2](#) (page 162)
- [iPhone 12 Pro 1 of 2](#) (page 163)
- [iPhone 12 Pro 2 of 2](#) (page 164)
- [iPhone 12 1 of 2](#) (page 165)
- [iPhone 12 2 of 2](#) (page 166)
- [iPhone 12 mini 1 of 2](#) (page 167)
- [iPhone 12 mini 2 of 2](#) (page 168)
- [iPhone SE \(2nd generation\)](#) (page 169)
- [iPhone 11 Pro Max](#) (page 170)
- [iPhone 11 Pro](#) (page 171)
- [iPhone 11](#) (page 172)
- [iPhone XS Max](#) (page 173)
- [iPhone XS](#) (page 174)
- [iPhone XR](#) (page 175)
- [iPhone X](#) (page 176)
- [iPhone 8 Plus](#) (page 177)
- [iPhone 8](#) (page 178)
- [iPhone 7 Plus](#) (page 179)
- [iPhone 7](#) (page 180)
- [iPhone 6s Plus](#) (page 181)
- [iPhone 6s](#) (page 182)
- [iPhone 6 Plus](#) (page 183)
- [iPhone 6](#) (page 184)
- [iPhone 5s & iPhone SE](#) (page 185)
- [iPhone 5c](#) (page 186)
- [iPhone 5](#) (page 187)
- [iPad Air \(4th generation\) 1 of 5](#) (page 188)
- [iPad Air \(4th generation\) 2 of 5](#) (page 189)
- [iPad Air \(4th generation\) 3 of 5](#) (page 190)
- [iPad Air \(4th generation\) 4 of 5](#) (page 191)
- [iPad Air \(4th generation\) 5 of 5](#) (page 192)

- [iPad Pro \(12.9-inch\) 4th Generation 1 of 5 \(page 193\)](#)
- [iPad Pro \(12.9-inch\) 4th Generation 2 of 5 \(page 194\)](#)
- [iPad Pro \(12.9-inch\) 4th Generation 3 of 5 \(page 195\)](#)
- [iPad Pro \(12.9-inch\) 4th Generation 4 of 5 \(page 196\)](#)
- [iPad Pro \(12.9-inch\) 4th Generation 5 of 5 \(page 197\)](#)
- [iPad Pro \(11-inch\) 2nd Generation 1 of 5 \(page 198\)](#)
- [iPad Pro \(11-inch\) 2nd Generation 2 of 5 \(page 199\)](#)
- [iPad Pro \(11-inch\) 2nd Generation 3 of 5 \(page 200\)](#)
- [iPad Pro \(11-inch\) 2nd Generation 4 of 5 \(page 201\)](#)
- [iPad Pro \(11-inch\) 2nd Generation 5 of 5 \(page 202\)](#)
- [iPad \(7th generation\) & iPad \(8th generation\) 1 of 3 \(page 203\)](#)
- [iPad \(7th generation\) & iPad \(8th generation\) 2 of 3 \(page 204\)](#)
- [iPad \(7th generation\) & iPad \(8th generation\) 3 of 3 \(page 205\)](#)
- [iPad Air \(3rd generation\) with Wi-Fi 1 of 3 \(page 206\)](#)
- [iPad Air \(3rd generation\) with Wi-Fi 2 of 3 \(page 207\)](#)
- [iPad Air \(3rd generation\) with Wi-Fi 3 of 3 \(page 208\)](#)
- [iPad Air \(3rd generation\) with Wi-Fi + Cellular 1 of 3 \(page 209\)](#)
- [iPad Air \(3rd generation\) with Wi-Fi + Cellular 2 of 3 \(page 210\)](#)
- [iPad Air \(3rd generation\) with Wi-Fi + Cellular 3 of 3 \(page 211\)](#)
- [iPad mini \(5th generation\) with Wi-Fi 1 of 3 \(page 212\)](#)
- [iPad mini \(5th generation\) with Wi-Fi 2 of 3 \(page 213\)](#)
- [iPad mini \(5th generation\) with Wi-Fi 3 of 3 \(page 214\)](#)
- [iPad mini \(5th generation\) with Wi-Fi + Cellular 1 of 3 \(page 215\)](#)
- [iPad mini \(5th generation\) with Wi-Fi + Cellular 2 of 3 \(page 216\)](#)
- [iPad mini \(5th generation\) with Wi-Fi + Cellular 3 of 3 \(page 217\)](#)
- [iPad Pro \(12.9-inch\) 3rd Generation 1 of 3 \(page 218\)](#)
- [iPad Pro \(12.9-inch\) 3rd Generation 2 of 3 \(page 219\)](#)
- [iPad Pro \(12.9-inch\) 3rd Generation 3 of 3 \(page 220\)](#)
- [iPad Pro \(11-inch\) 1 of 3 \(page 221\)](#)
- [iPad Pro \(11-inch\) 2 of 3 \(page 222\)](#)
- [iPad Pro \(11-inch\) 3 of 3 \(page 223\)](#)
- [iPad Pro \(12.9-inch\) 2nd Generation with Wi-Fi \(page 224\)](#)
- [iPad Pro \(12.9-inch\) 2nd Generation with Wi-Fi + Cellular \(page 225\)](#)
- [iPad Pro \(12.9-inch\) 2nd Generation Magnet/Hall Effect Sensors 1 of 2 \(page 226\)](#)
- [iPad Pro \(12.9-inch\) 2nd Generation Magnet/Hall Effect Sensors 2 of 2 \(page 227\)](#)
- [iPad Pro \(10.5-inch\) with Wi-Fi \(page 228\)](#)
- [iPad Pro \(10.5-inch\) with Wi-Fi + Cellular \(page 229\)](#)
- [iPad Pro \(10.5-inch\) Magnet/Hall Effect Sensors 1 of 2 \(page 230\)](#)
- [iPad Pro \(10.5-inch\) Magnet/Hall Effect Sensors 2 of 2 \(page 231\)](#)
- [iPad \(5th and 6th generation\) with Wi-Fi + Cellular \(page 232\)](#)

- [iPad \(5th and 6th generation\) Magnet/Hall Effect Sensors 1 of 2](#) (page 233)
- [iPad \(5th and 6th generation\) Magnet/Hall Effect Sensors 2 of 2](#) (page 234)
- [iPad Pro \(9.7-inch\) with Wi-Fi](#) (page 235)
- [iPad Pro \(9.7-inch\) with Wi-Fi + Cellular](#) (page 236)
- [iPad Pro \(9.7-inch\) Magnet/Hall Effect Sensors 1 of 2](#) (page 237)
- [iPad Pro \(9.7-inch\) Magnet/Hall Effect Sensors 2 of 2](#) (page 238)
- [iPad Pro \(12.9-inch\) 1st Generation with Wi-Fi](#) (page 239)
- [iPad Pro \(12.9-inch\) 1st Generation with Wi-Fi + Cellular](#) (page 240)
- [iPad Pro \(12.9-inch\) 1st Generation Magnet/Hall Effect Sensors 1 of 2](#) (page 241)
- [iPad Pro \(12.9-inch\) 1st Generation Magnet/Hall Effect Sensors 2 of 2](#) (page 242)
- [iPad mini 4 with Wi-Fi](#) (page 243)
- [iPad mini 4 with Wi-Fi + Cellular](#) (page 244)
- [iPad mini 4 Magnet/Hall Effect Sensors](#) (page 245)
- [iPad Air 2 with Wi-Fi](#) (page 246)
- [iPad Air 2 with Wi-Fi + Cellular](#) (page 247)
- [iPad mini 2 & iPad mini 3 with Wi-Fi](#) (page 248)
- [iPad mini 2 & iPad mini 3 with Wi-Fi + Cellular](#) (page 249)
- [iPad Air with Wi-Fi](#) (page 250)
- [iPad Air with Wi-Fi + Cellular](#) (page 251)
- [iPad mini with Wi-Fi](#) (page 252)
- [iPad mini with Wi-Fi + Cellular](#) (page 253)
- [iPad \(4th generation\) with Wi-Fi](#) (page 254)
- [iPad \(4th generation\) with Wi-Fi + Cellular](#) (page 255)
- [iPod touch \(6th generation\) & iPod touch \(7th generation\)](#) (page 256)
- [iPod touch \(5th generation\)](#) (page 257)
- [Apple Watch Series 6, 44 mm](#) (page 258)
- [Apple Watch Series 6, 40 mm](#) (page 259)
- [Apple Watch SE, 44 mm](#) (page 260)
- [Apple Watch SE, 40 mm](#) (page 261)
- [Apple Watch Series 5, 44 mm](#) (page 262)
- [Apple Watch Series 5, 40 mm](#) (page 263)
- [Apple Watch Series 5 Ceramic, 44 mm](#) (page 264)
- [Apple Watch Series 5 Ceramic, 40 mm](#) (page 265)
- [Apple Watch Series 4, 44 mm](#) (page 266)
- [Apple Watch Series 4, 40 mm](#) (page 267)
- [Apple Watch Series 3 Ceramic, 42 mm](#) (page 268)
- [Apple Watch Series 3 Ceramic, 38 mm](#) (page 269)
- [Apple Watch Series 3 Metal, 42 mm](#) (page 270)
- [Apple Watch Series 3 Metal, 38 mm](#) (page 271)
- [Apple Watch Series 2 Ceramic, 42 mm](#) (page 272)

- [Apple Watch Series 2 Ceramic, 38 mm](#) (page 273)
- [Apple Watch Series 2 Metal, 42 mm](#) (page 274)
- [Apple Watch Series 2 Metal, 38 mm](#) (page 275)
- [Apple Watch \(1st generation\) & Apple Watch Series 1, 42 mm](#) (page 276)
- [Apple Watch \(1st generation\) & Apple Watch Series 1, 38 mm](#) (page 277)
- [AirPods Pro Wireless Charging Case](#) (page 278)
- [AirPods Wireless Charging Case](#) (page 279)
- [AirPods Pro](#) (page 280)
- [AirPods](#) (page 281)

40.1 iPhone 12 Pro Max 1 of 2

NOTES (UNLESS OTHERWISE SPECIFIED)

- 1 NO METAL CONTACT WITH IPHONE.
- 2 DO NOT OBSTRUCT PORTS.
- 3 DO NOT OBSTRUCT THE IMAGING FEATURES: FRONT CAMERA, REAR CAMERAS, REAR FLASH.
- 4 DO NOT OBSTRUCT FORWARD FACING SENSORS.
- 5 RELATIVE MAGNETIC PERMEABILITY OF ANY METAL USED ON CASE: 1.05 MAX. PER ASTM A342/A342M-14.
- 6 DO NOT TOUCH GLASS.
- 7 NO MAGNETS ON REAR OF PRODUCT EXCEPT MAGSAFE MAGNETS.
- 8 CASE THICKNESS ON BACKSIDE OF PRODUCT: 2.1 mm MAX TO ENSURE FULL FUNCTIONALITY.

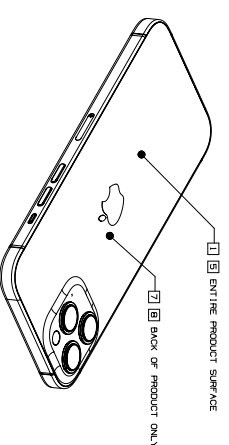
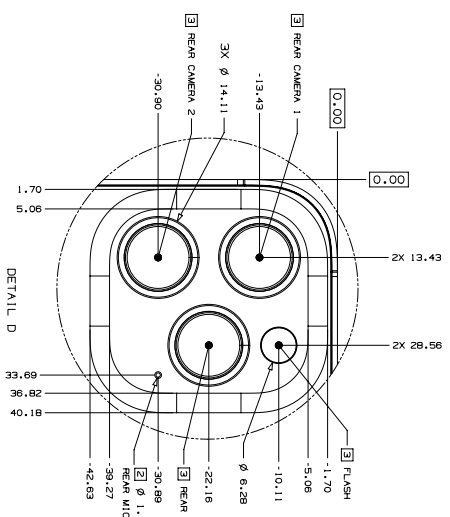
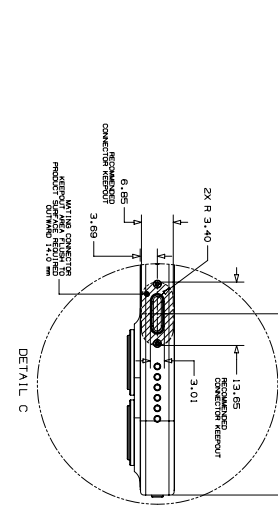
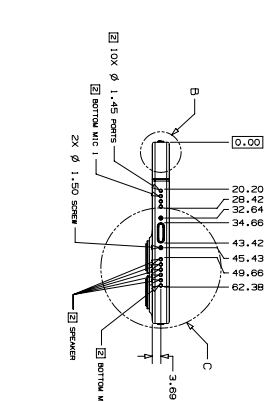
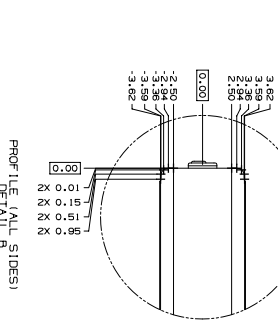
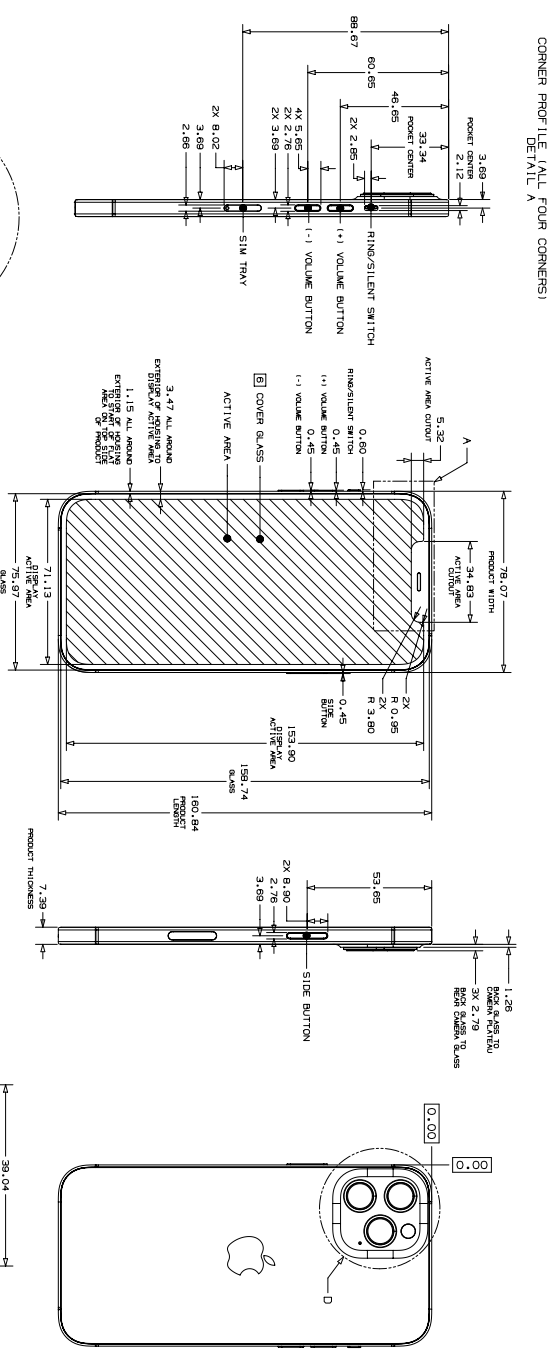
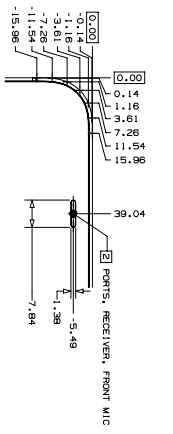

| METRIC | | Apple Inc. | |
|--|------------|------------|-------------------|
| DATE | 10/19/20 | TITLE | iPhone 12 Pro Max |
| APPROVED BY | Apple Inc. | SCALE | NONE |
| DATE | 10/19/20 | SHEET | 1 of 2 |
| <small>THE INFORMATION CONTAINED HEREIN IS THE PROPERTY OF APPLE INC. THE DESIGN AND THE APPEARANCE OF THE PRODUCT IS THE PROPERTY OF APPLE INC. THE DESIGN AND THE APPEARANCE OF THE PRODUCT IS THE PROPERTY OF APPLE INC. THE DESIGN AND THE APPEARANCE OF THE PRODUCT IS THE PROPERTY OF APPLE INC.</small> | | | |

40.3 iPhone 12 Pro 1 of 2

NOTES (UNLESS OTHERWISE SPECIFIED)

- 1 NO METAL CONTACT WITH IPHONE.
- 2 DO NOT OBSTRUCT PORTS.
- 3 DO NOT OBSTRUCT THE IMAGING FEATURES: FRONT CAMERA, REAR CAMERAS, REAR FLASH.
- 4 DO NOT OBSTRUCT FORWARD FACING SENSORS.
- 5 RELATIVE MAGNETIC PERMEABILITY OF ANY METAL USED ON CASE: 1.05 MAX. PER ASTM A342/A342M-14.
- 6 DO NOT TOUCH GLASS.
- 7 NO MAGNETS ON REAR OF PRODUCT EXCEPT MAGSAFE MAGNETS.
- 8 CASE THICKNESS ON BACKSIDE OF PRODUCT: 2.1 mm MAX TO ENSURE FULL FUNCTIONALITY.

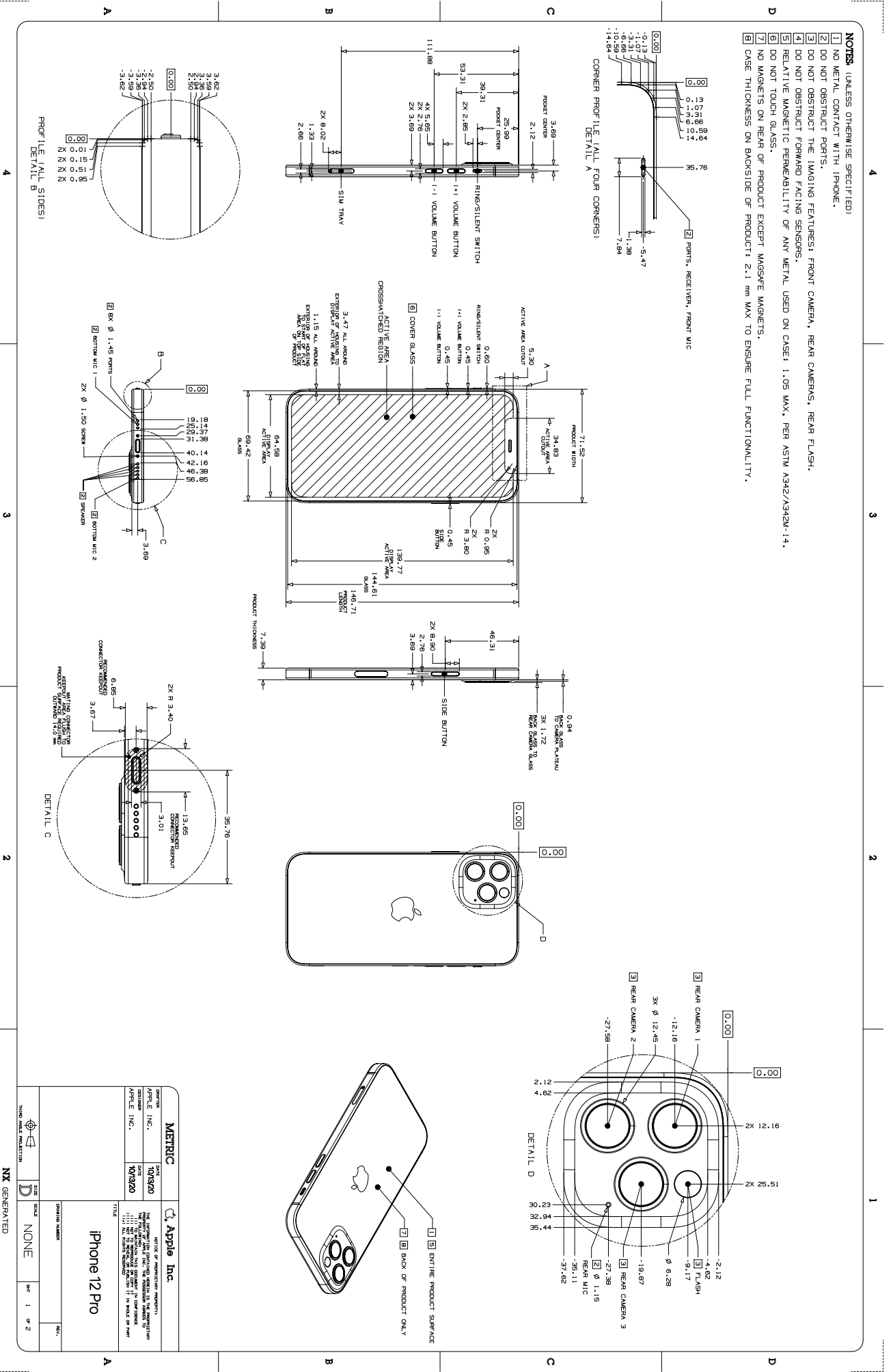

| METRIC | | Apple Inc. | |
|----------------|---------------|--|---|
| DATE | 10/19/20 | THE INFORMATION CONTAINED HEREIN IS PROPRIETARY AND CONFIDENTIAL TO APPLE INC. ALL RIGHTS RESERVED. | |
| DATE | 10/19/20 | THIS DOCUMENT IS THE PROPERTY OF APPLE INC. IT IS TO BE USED ONLY FOR THE PURPOSES SPECIFIED IN THE TITLE AND NOT BE REPRODUCED OR TRANSMITTED IN ANY FORM OR BY ANY MEANS, ELECTRONIC OR MECHANICAL, INCLUDING PHOTOCOPYING, RECORDING, OR BY ANY INFORMATION STORAGE AND RETRIEVAL SYSTEM. | |
| TITLE | iPhone 12 Pro | | |
| DRAWING NUMBER | | | |
| SCALE | NONE | | |
| SHEET | 1 | OF | 2 |

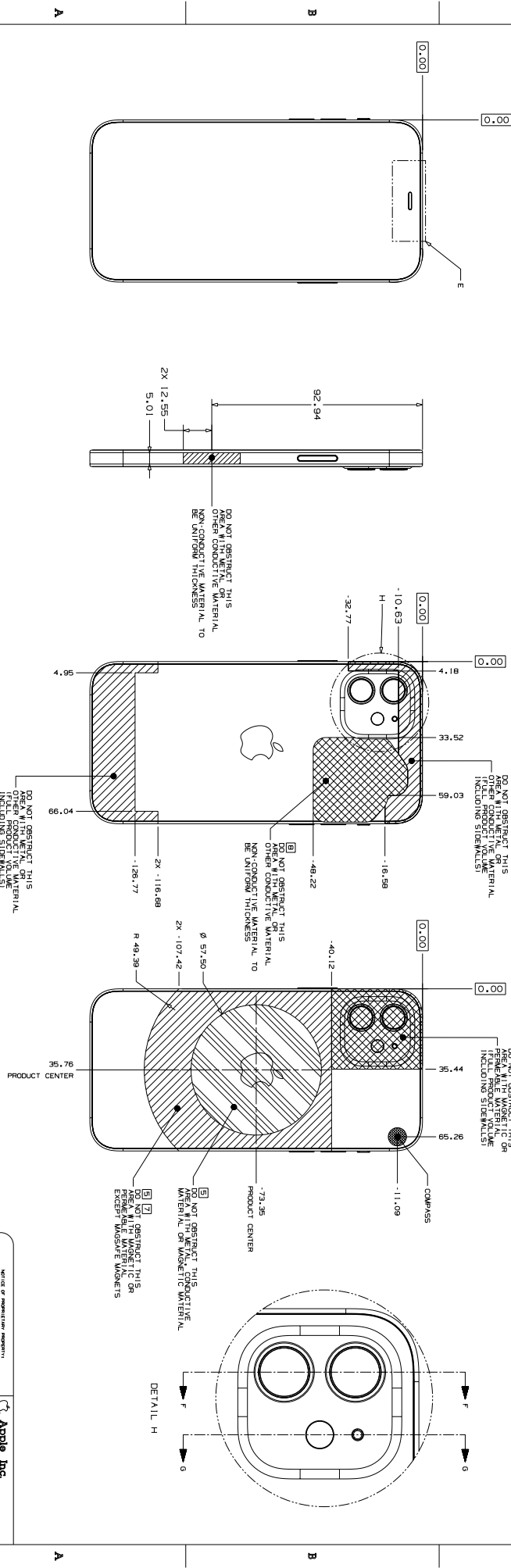
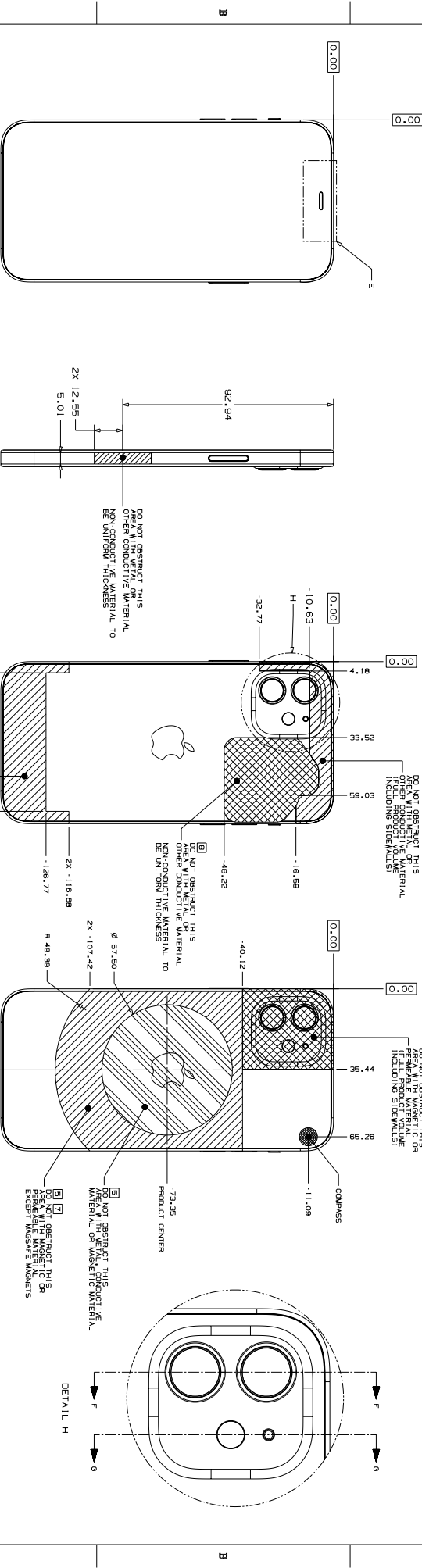
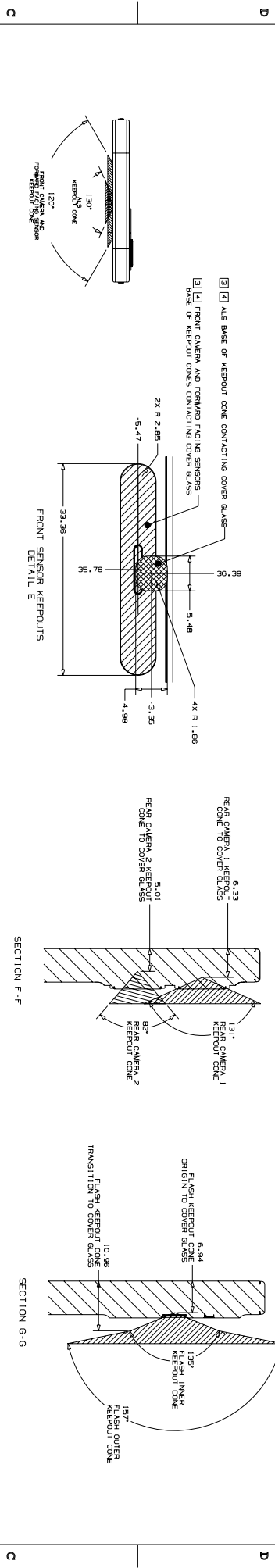
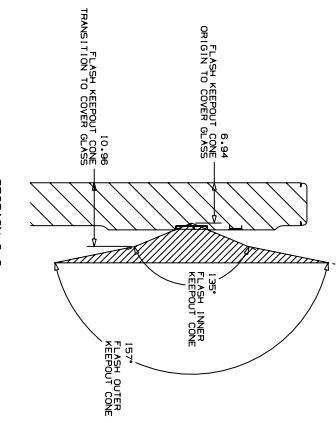
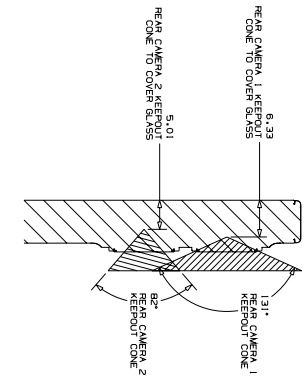
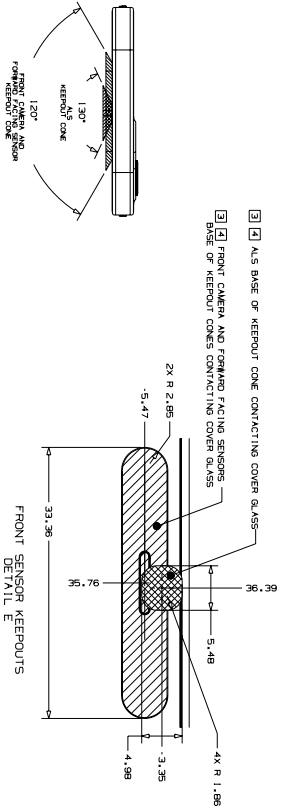

Apple Inc.
11000 Apple Blvd.
Cupertino, CA 95014
Copyright © 2020 Apple Inc. All Rights Reserved.

Version 1.0
Date: 11/19/2020
Author: [Redacted]
Reviewer: [Redacted]
Approved: [Redacted]

Apple Inc.
11000 Apple Blvd.
Cupertino, CA 95014
Copyright © 2020 Apple Inc. All Rights Reserved.

Product: iPhone 12
Sheet: 2 of 2

40.9 iPhone SE (2nd generation)

NOTES:

- [1] NO METAL CONTACT WITH IPHONE.
- [2] DO NOT OBSTRUCT THE ACOUSTIC OPENINGS: FRONT MIC, REAR MIC, BOTTOM MIC1, BOTTOM MIC2, RECEIVER, AND SPEAKER.
- [3] DO NOT OBSTRUCT THE IMAGING FEATURES: FRONT CAMERA, REAR CAMERA, REAR FLASH.
- [4] DO NOT OBSTRUCT THE PROXIMITY SENSOR OR AMBIENT LIGHT SENSOR (ALS).
- [5] DO NOT OBSTRUCT THE HOME/TOUCH ID SENSOR.
- [6] DO NOT TOUCH GLASS.
- [7] DO NOT OBSTRUCT PORTS.
- [8] NO HIGH POWERED MAGNETS.
- [9] RELATIVE MAGNETIC PERMEABILITY OF ANY METAL USED ON CASE: 1.05 MAX.
- [10] CASE THICKNESS ON BACKSIDE OF PRODUCT: 5.0 mm MAX TO ENSURE FULL FUNCTIONALITY.

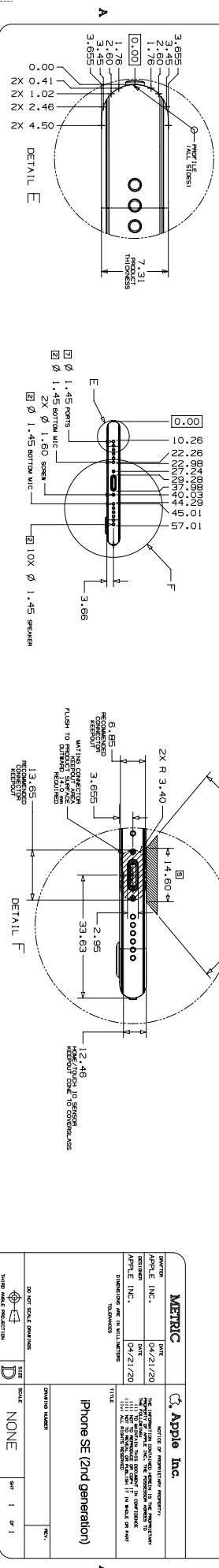
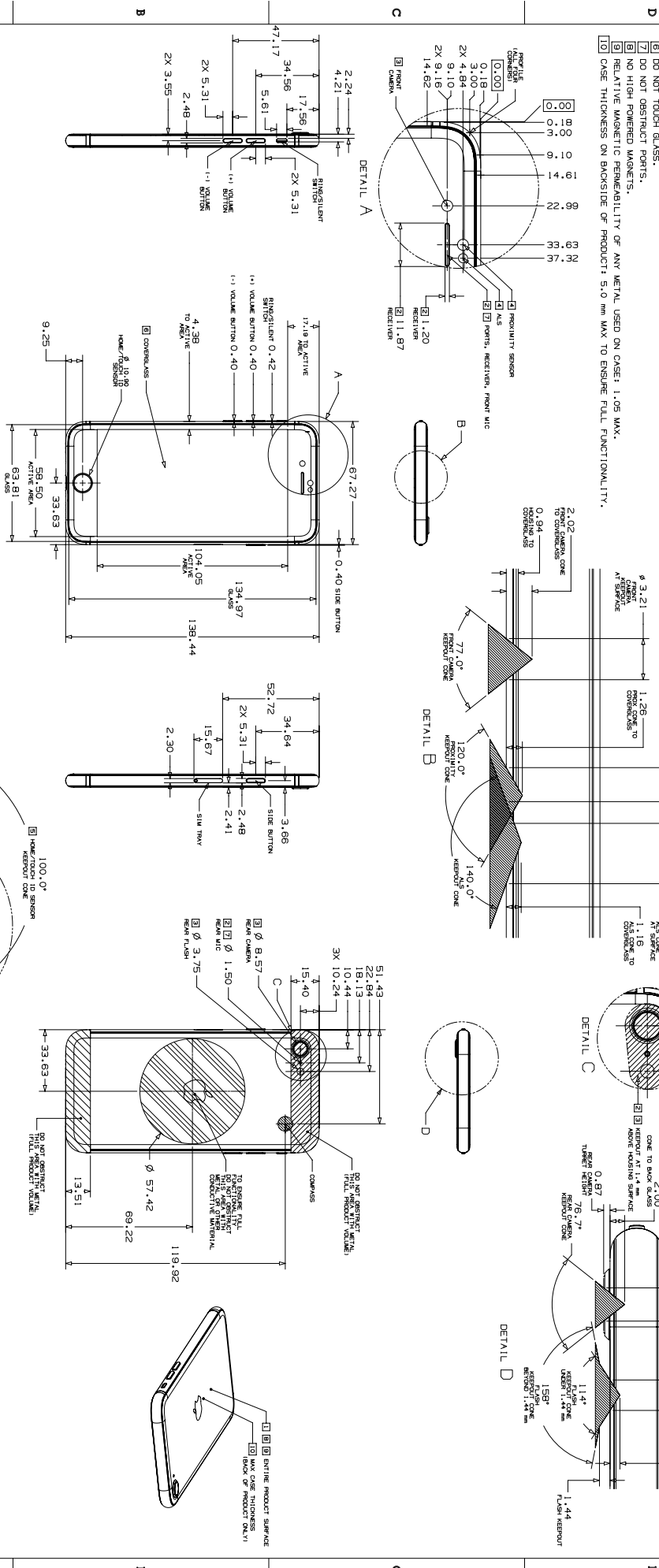

| | |
|---|----------------------|
| METRIC | Apple Inc. |
| DATE: 04/21/20 | REVISION: 1 |
| <p>THE INFORMATION CONTAINED HEREIN IS PROPRIETARY AND CONFIDENTIAL TO APPLE INC. (THE "PRODUCT"). THIS DOCUMENT IS FOR INTERNAL USE ONLY AND IS NOT TO BE DISTRIBUTED OUTSIDE OF APPLE INC. OR ITS DIRECT REPORTING LINES. ANY INFORMATION CONTAINED HEREIN IS UNCLASSIFIED.</p> | |
| TITLE: iPhone SE (2nd generation) | DRAWING NUMBER: NONE |
| SCALE: NONE | SHEET: 1 OF 1 |
| <p>DO NOT SCALE DIMENSIONS</p> <p>HAND MADE PROTECTION</p> | <p>MX GENERATED</p> |

40.10 iPhone 11 Pro Max

NOTES (UNLESS OTHERWISE SPECIFIED)

- 1 NO METAL CONTACT WITH IPHONE.
- 2 DO NOT OBSTRUCT THE ACOUSTIC OPENINGS: FRONT MIC, REAR MIC, BOTTOM MIC1, BOTTOM MIC2, RECEIVER AND SPEAKER.
- 3 DO NOT OBSTRUCT THE IMAGING FEATURES: FRONT CAMERA, REAR CAMERAS, REAR FLASH.
- 4 DO NOT OBSTRUCT FORWARD FACING SENSORS.
- 5 RELATIVE MAGNETIC PERMEABILITY OF ANY METAL USED ON CASE: 1.05 MAX, PER ASTM A342/A342M-14.
- 6 DO NOT TOUCH GLASS.
- 7 DO NOT OBSTRUCT PORTS.
- 8 NO HIGH POWERED MAGNETS.
- 9 CASE THICKNESS ON BACKSIDE OF PRODUCT: 5.0 mm MAX TO ENSURE FULL FUNCTIONALITY.

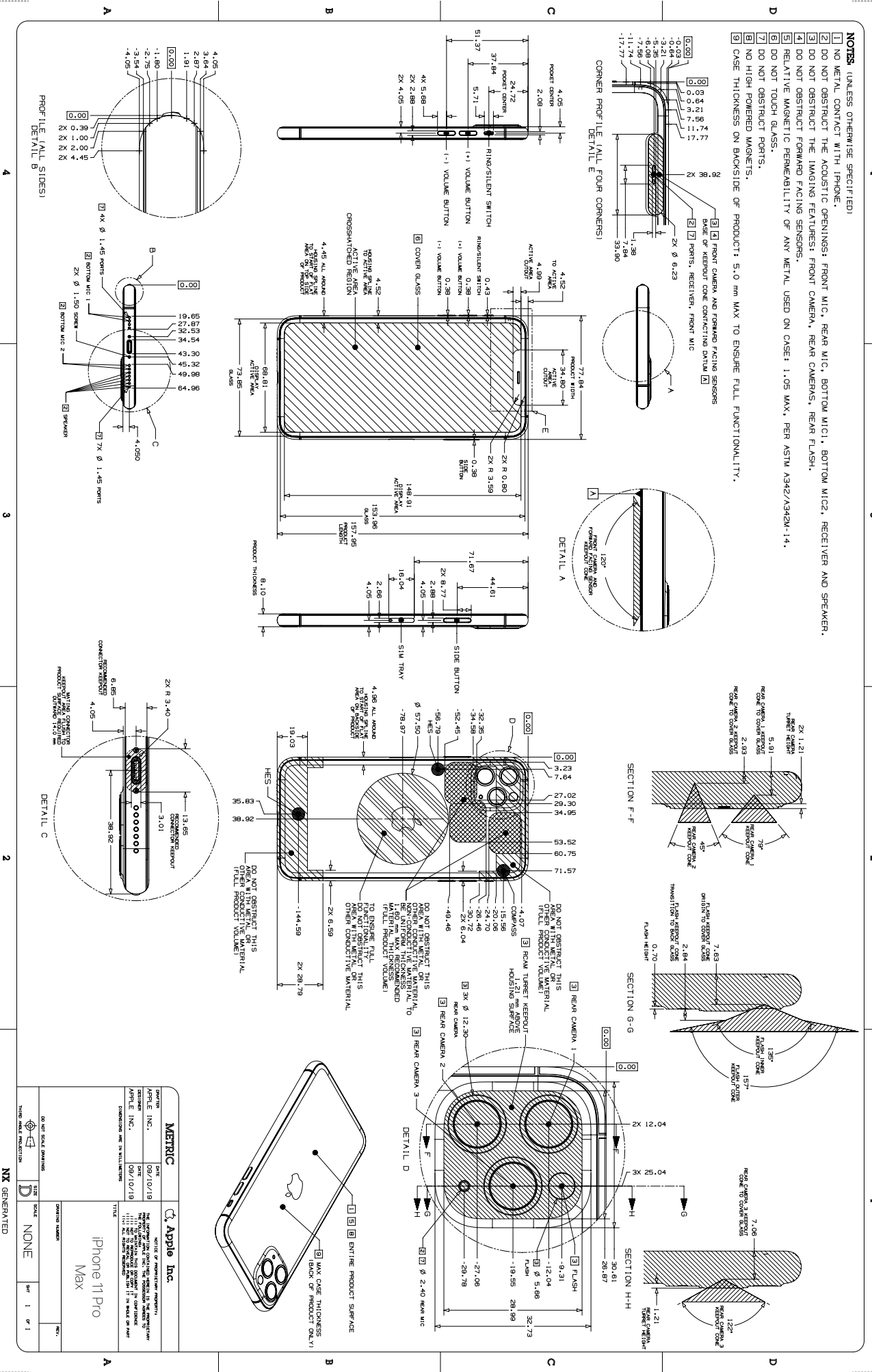

| METRIC | | Apple Inc. | |
|---|----------|------------|----------|
| DATE | DATE | VERSION | DATE |
| 09/10/18 | 09/10/18 | 1 | 09/10/18 |
| THE INFORMATION CONTAINED HEREIN IS THE PROPERTY OF APPLE INC. AND IS UNCLASSIFIED. IT IS TO BE KEPT UNCLASSIFIED TO THE EXTENT POSSIBLE. IT IS TO BE RELEASED TO THE PUBLIC IN ACCORDANCE WITH THE FOIA. | | | |
| DRAWING NO. iPhone 11 Pro Max | | | |
| TITLE | | | |
| DRAWING NUMBER | | | |
| SHEET 1 OF 1 | | | |

- NOTES:**
- NO METAL CONTACT WITH IPHONE.
 - DO NOT OBSTRUCT THE ACOUSTIC OPENINGS: FRONT MIC, REAR MIC, BOTTOM MIC1, BOTTOM MIC2, RECEIVER AND SPEAKER.
 - DO NOT OBSTRUCT THE IMAGING FEATURES: FRONT CAMERA, REAR CAMERA, REAR FLASH.
 - DO NOT OBSTRUCT FORWARD FACING SENSORS.
 - RELATIVE MAGNETIC PERMEABILITY OF ANY METAL USED ON CASE: 1.05 MAX, PER ASTM A342/A342M-14.
 - DO NOT TOUGH GLASS.
 - DO NOT OBSTRUCT PORTS.
 - NO HIGH POWERED MAGNETS.
 - CASE THICKNESS ON BACKSIDE OF PRODUCT: 5.0 mm MAX TO ENSURE FULL FUNCTIONALITY.

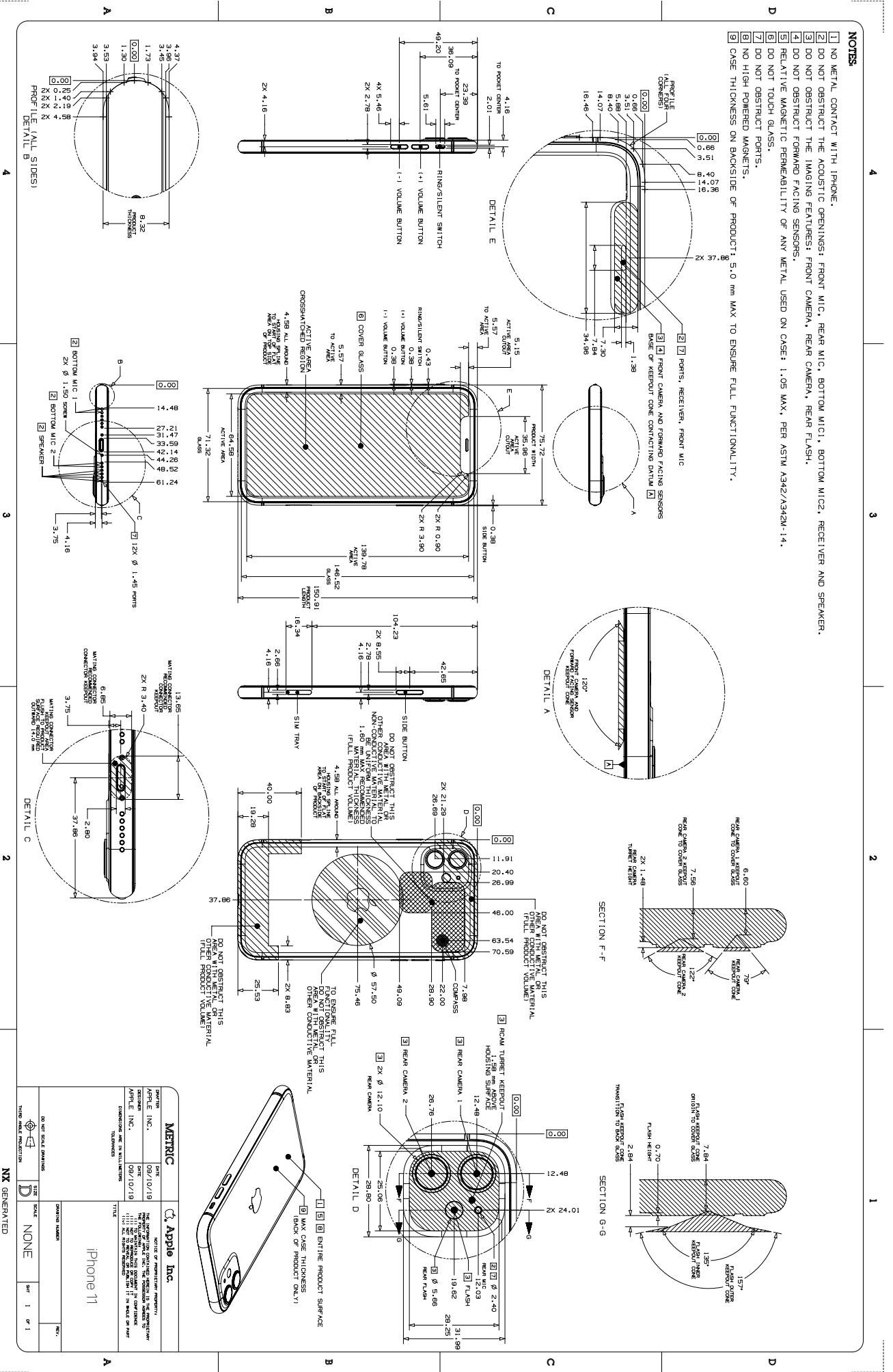

| METRIC | | Apple Inc. | |
|----------|--------------|------------|--------------|
| DATE | DESCRIPTION | DATE | DESCRIPTION |
| 09/10/18 | REVISION 1 | 09/10/18 | REVISION 1 |
| 09/10/18 | REVISION 2 | 09/10/18 | REVISION 2 |
| 09/10/18 | REVISION 3 | 09/10/18 | REVISION 3 |
| 09/10/18 | REVISION 4 | 09/10/18 | REVISION 4 |
| 09/10/18 | REVISION 5 | 09/10/18 | REVISION 5 |
| 09/10/18 | REVISION 6 | 09/10/18 | REVISION 6 |
| 09/10/18 | REVISION 7 | 09/10/18 | REVISION 7 |
| 09/10/18 | REVISION 8 | 09/10/18 | REVISION 8 |
| 09/10/18 | REVISION 9 | 09/10/18 | REVISION 9 |
| 09/10/18 | REVISION 10 | 09/10/18 | REVISION 10 |
| 09/10/18 | REVISION 11 | 09/10/18 | REVISION 11 |
| 09/10/18 | REVISION 12 | 09/10/18 | REVISION 12 |
| 09/10/18 | REVISION 13 | 09/10/18 | REVISION 13 |
| 09/10/18 | REVISION 14 | 09/10/18 | REVISION 14 |
| 09/10/18 | REVISION 15 | 09/10/18 | REVISION 15 |
| 09/10/18 | REVISION 16 | 09/10/18 | REVISION 16 |
| 09/10/18 | REVISION 17 | 09/10/18 | REVISION 17 |
| 09/10/18 | REVISION 18 | 09/10/18 | REVISION 18 |
| 09/10/18 | REVISION 19 | 09/10/18 | REVISION 19 |
| 09/10/18 | REVISION 20 | 09/10/18 | REVISION 20 |
| 09/10/18 | REVISION 21 | 09/10/18 | REVISION 21 |
| 09/10/18 | REVISION 22 | 09/10/18 | REVISION 22 |
| 09/10/18 | REVISION 23 | 09/10/18 | REVISION 23 |
| 09/10/18 | REVISION 24 | 09/10/18 | REVISION 24 |
| 09/10/18 | REVISION 25 | 09/10/18 | REVISION 25 |
| 09/10/18 | REVISION 26 | 09/10/18 | REVISION 26 |
| 09/10/18 | REVISION 27 | 09/10/18 | REVISION 27 |
| 09/10/18 | REVISION 28 | 09/10/18 | REVISION 28 |
| 09/10/18 | REVISION 29 | 09/10/18 | REVISION 29 |
| 09/10/18 | REVISION 30 | 09/10/18 | REVISION 30 |
| 09/10/18 | REVISION 31 | 09/10/18 | REVISION 31 |
| 09/10/18 | REVISION 32 | 09/10/18 | REVISION 32 |
| 09/10/18 | REVISION 33 | 09/10/18 | REVISION 33 |
| 09/10/18 | REVISION 34 | 09/10/18 | REVISION 34 |
| 09/10/18 | REVISION 35 | 09/10/18 | REVISION 35 |
| 09/10/18 | REVISION 36 | 09/10/18 | REVISION 36 |
| 09/10/18 | REVISION 37 | 09/10/18 | REVISION 37 |
| 09/10/18 | REVISION 38 | 09/10/18 | REVISION 38 |
| 09/10/18 | REVISION 39 | 09/10/18 | REVISION 39 |
| 09/10/18 | REVISION 40 | 09/10/18 | REVISION 40 |
| 09/10/18 | REVISION 41 | 09/10/18 | REVISION 41 |
| 09/10/18 | REVISION 42 | 09/10/18 | REVISION 42 |
| 09/10/18 | REVISION 43 | 09/10/18 | REVISION 43 |
| 09/10/18 | REVISION 44 | 09/10/18 | REVISION 44 |
| 09/10/18 | REVISION 45 | 09/10/18 | REVISION 45 |
| 09/10/18 | REVISION 46 | 09/10/18 | REVISION 46 |
| 09/10/18 | REVISION 47 | 09/10/18 | REVISION 47 |
| 09/10/18 | REVISION 48 | 09/10/18 | REVISION 48 |
| 09/10/18 | REVISION 49 | 09/10/18 | REVISION 49 |
| 09/10/18 | REVISION 50 | 09/10/18 | REVISION 50 |
| 09/10/18 | REVISION 51 | 09/10/18 | REVISION 51 |
| 09/10/18 | REVISION 52 | 09/10/18 | REVISION 52 |
| 09/10/18 | REVISION 53 | 09/10/18 | REVISION 53 |
| 09/10/18 | REVISION 54 | 09/10/18 | REVISION 54 |
| 09/10/18 | REVISION 55 | 09/10/18 | REVISION 55 |
| 09/10/18 | REVISION 56 | 09/10/18 | REVISION 56 |
| 09/10/18 | REVISION 57 | 09/10/18 | REVISION 57 |
| 09/10/18 | REVISION 58 | 09/10/18 | REVISION 58 |
| 09/10/18 | REVISION 59 | 09/10/18 | REVISION 59 |
| 09/10/18 | REVISION 60 | 09/10/18 | REVISION 60 |
| 09/10/18 | REVISION 61 | 09/10/18 | REVISION 61 |
| 09/10/18 | REVISION 62 | 09/10/18 | REVISION 62 |
| 09/10/18 | REVISION 63 | 09/10/18 | REVISION 63 |
| 09/10/18 | REVISION 64 | 09/10/18 | REVISION 64 |
| 09/10/18 | REVISION 65 | 09/10/18 | REVISION 65 |
| 09/10/18 | REVISION 66 | 09/10/18 | REVISION 66 |
| 09/10/18 | REVISION 67 | 09/10/18 | REVISION 67 |
| 09/10/18 | REVISION 68 | 09/10/18 | REVISION 68 |
| 09/10/18 | REVISION 69 | 09/10/18 | REVISION 69 |
| 09/10/18 | REVISION 70 | 09/10/18 | REVISION 70 |
| 09/10/18 | REVISION 71 | 09/10/18 | REVISION 71 |
| 09/10/18 | REVISION 72 | 09/10/18 | REVISION 72 |
| 09/10/18 | REVISION 73 | 09/10/18 | REVISION 73 |
| 09/10/18 | REVISION 74 | 09/10/18 | REVISION 74 |
| 09/10/18 | REVISION 75 | 09/10/18 | REVISION 75 |
| 09/10/18 | REVISION 76 | 09/10/18 | REVISION 76 |
| 09/10/18 | REVISION 77 | 09/10/18 | REVISION 77 |
| 09/10/18 | REVISION 78 | 09/10/18 | REVISION 78 |
| 09/10/18 | REVISION 79 | 09/10/18 | REVISION 79 |
| 09/10/18 | REVISION 80 | 09/10/18 | REVISION 80 |
| 09/10/18 | REVISION 81 | 09/10/18 | REVISION 81 |
| 09/10/18 | REVISION 82 | 09/10/18 | REVISION 82 |
| 09/10/18 | REVISION 83 | 09/10/18 | REVISION 83 |
| 09/10/18 | REVISION 84 | 09/10/18 | REVISION 84 |
| 09/10/18 | REVISION 85 | 09/10/18 | REVISION 85 |
| 09/10/18 | REVISION 86 | 09/10/18 | REVISION 86 |
| 09/10/18 | REVISION 87 | 09/10/18 | REVISION 87 |
| 09/10/18 | REVISION 88 | 09/10/18 | REVISION 88 |
| 09/10/18 | REVISION 89 | 09/10/18 | REVISION 89 |
| 09/10/18 | REVISION 90 | 09/10/18 | REVISION 90 |
| 09/10/18 | REVISION 91 | 09/10/18 | REVISION 91 |
| 09/10/18 | REVISION 92 | 09/10/18 | REVISION 92 |
| 09/10/18 | REVISION 93 | 09/10/18 | REVISION 93 |
| 09/10/18 | REVISION 94 | 09/10/18 | REVISION 94 |
| 09/10/18 | REVISION 95 | 09/10/18 | REVISION 95 |
| 09/10/18 | REVISION 96 | 09/10/18 | REVISION 96 |
| 09/10/18 | REVISION 97 | 09/10/18 | REVISION 97 |
| 09/10/18 | REVISION 98 | 09/10/18 | REVISION 98 |
| 09/10/18 | REVISION 99 | 09/10/18 | REVISION 99 |
| 09/10/18 | REVISION 100 | 09/10/18 | REVISION 100 |

40.13 iPhone XS Max

NOTES (UNLESS OTHERWISE SPECIFIED)

- 1 NO METAL CONTACT WITH IPHONE.
- 2 DO NOT OBSTRUCT THE ACOUSTIC OPENINGS: FRONT MIC, REAR MIC, BOTTOM MIC1, BOTTOM MIC2, RECEIVER AND SPEAKER.
- 3 DO NOT OBSTRUCT THE IMAGING FEATURES: FRONT CAMERA, REAR CAMERA, REAR FLASH.
- 4 DO NOT OBSTRUCT FORWARD FACING SENSORS.
- 5 RELATIVE MAGNETIC PERMEABILITY OF ANY METAL USED ON CASE: 1.05 MAX, PER ASTM A342/A342M-14.
- 6 DO NOT TOUCH GLASS.
- 7 DO NOT OBSTRUCT PORTS.
- 8 NO HIGH POWERED MAGNETS.
- 9 CASE THICKNESS ON BACKSIDE OF PRODUCT: 5.0 mm MAX TO ENSURE FULL FUNCTIONALITY.

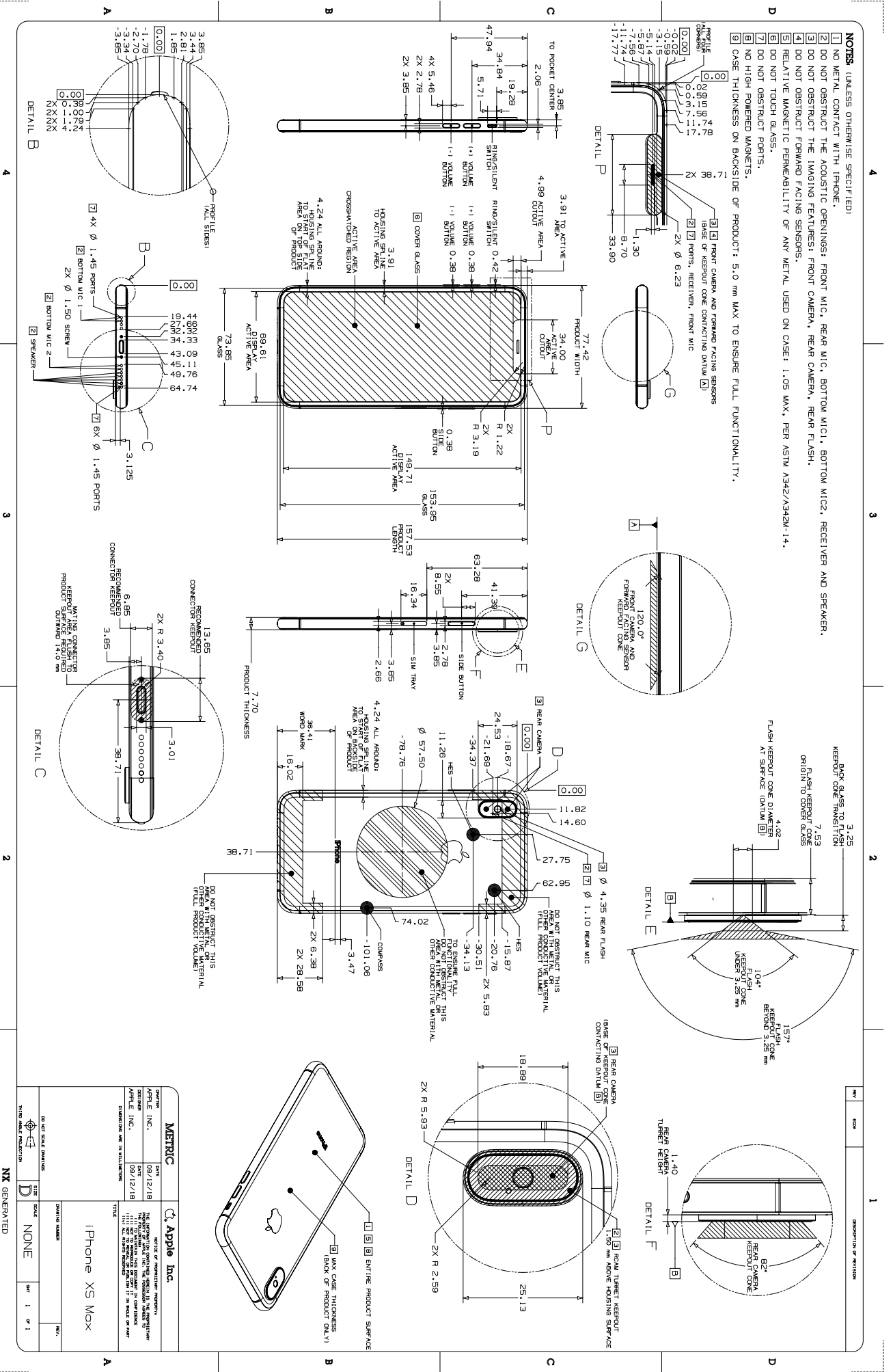

| DATE | DESCRIPTION OF REVISION |
|----------|-------------------------|
| 09/12/18 | 1 |
| 09/12/18 | 2 |
| 09/12/18 | 3 |
| 09/12/18 | 4 |
| 09/12/18 | 5 |
| 09/12/18 | 6 |
| 09/12/18 | 7 |
| 09/12/18 | 8 |
| 09/12/18 | 9 |
| 09/12/18 | 10 |
| 09/12/18 | 11 |
| 09/12/18 | 12 |
| 09/12/18 | 13 |
| 09/12/18 | 14 |
| 09/12/18 | 15 |
| 09/12/18 | 16 |
| 09/12/18 | 17 |
| 09/12/18 | 18 |
| 09/12/18 | 19 |
| 09/12/18 | 20 |
| 09/12/18 | 21 |
| 09/12/18 | 22 |
| 09/12/18 | 23 |
| 09/12/18 | 24 |
| 09/12/18 | 25 |
| 09/12/18 | 26 |
| 09/12/18 | 27 |
| 09/12/18 | 28 |
| 09/12/18 | 29 |
| 09/12/18 | 30 |
| 09/12/18 | 31 |
| 09/12/18 | 32 |
| 09/12/18 | 33 |
| 09/12/18 | 34 |
| 09/12/18 | 35 |
| 09/12/18 | 36 |
| 09/12/18 | 37 |
| 09/12/18 | 38 |
| 09/12/18 | 39 |
| 09/12/18 | 40 |
| 09/12/18 | 41 |
| 09/12/18 | 42 |
| 09/12/18 | 43 |
| 09/12/18 | 44 |
| 09/12/18 | 45 |
| 09/12/18 | 46 |
| 09/12/18 | 47 |
| 09/12/18 | 48 |
| 09/12/18 | 49 |
| 09/12/18 | 50 |
| 09/12/18 | 51 |
| 09/12/18 | 52 |
| 09/12/18 | 53 |
| 09/12/18 | 54 |
| 09/12/18 | 55 |
| 09/12/18 | 56 |
| 09/12/18 | 57 |
| 09/12/18 | 58 |
| 09/12/18 | 59 |
| 09/12/18 | 60 |
| 09/12/18 | 61 |
| 09/12/18 | 62 |
| 09/12/18 | 63 |
| 09/12/18 | 64 |
| 09/12/18 | 65 |
| 09/12/18 | 66 |
| 09/12/18 | 67 |
| 09/12/18 | 68 |
| 09/12/18 | 69 |
| 09/12/18 | 70 |
| 09/12/18 | 71 |
| 09/12/18 | 72 |
| 09/12/18 | 73 |
| 09/12/18 | 74 |
| 09/12/18 | 75 |
| 09/12/18 | 76 |
| 09/12/18 | 77 |
| 09/12/18 | 78 |
| 09/12/18 | 79 |
| 09/12/18 | 80 |
| 09/12/18 | 81 |
| 09/12/18 | 82 |
| 09/12/18 | 83 |
| 09/12/18 | 84 |
| 09/12/18 | 85 |
| 09/12/18 | 86 |
| 09/12/18 | 87 |
| 09/12/18 | 88 |
| 09/12/18 | 89 |
| 09/12/18 | 90 |
| 09/12/18 | 91 |
| 09/12/18 | 92 |
| 09/12/18 | 93 |
| 09/12/18 | 94 |
| 09/12/18 | 95 |
| 09/12/18 | 96 |
| 09/12/18 | 97 |
| 09/12/18 | 98 |
| 09/12/18 | 99 |
| 09/12/18 | 100 |

40.16 iPhone X

NOTES

- 1 NO METAL CONTACT WITH IPHONE.
- 2 DO NOT OBSTRUCT THE ACOUSTIC OPENINGS: FRONT MIC, REAR MIC, BOTTOM MIC1, BOTTOM MIC2, RECEIVER AND SPEAKER.
- 3 DO NOT OBSTRUCT THE IMAGING FEATURES: FRONT CAMERA, REAR CAMERA, REAR CAMERA, REAR FLASH.
- 4 DO NOT OBSTRUCT FORWARD FACING SENSORS.
- 5 RELATIVE MAGNETIC PERMEABILITY OF ANY METAL USED ON CASE: 1.05 MAX.
- 6 DO NOT OBSTRUCT PORTS.
- 7 NO HIGH POWERED MAGNETS.
- 8 CASE THICKNESS ON BACKSIDE OF PRODUCT: 5.0 mm MAX TO ENSURE FULL FUNCTIONALITY.

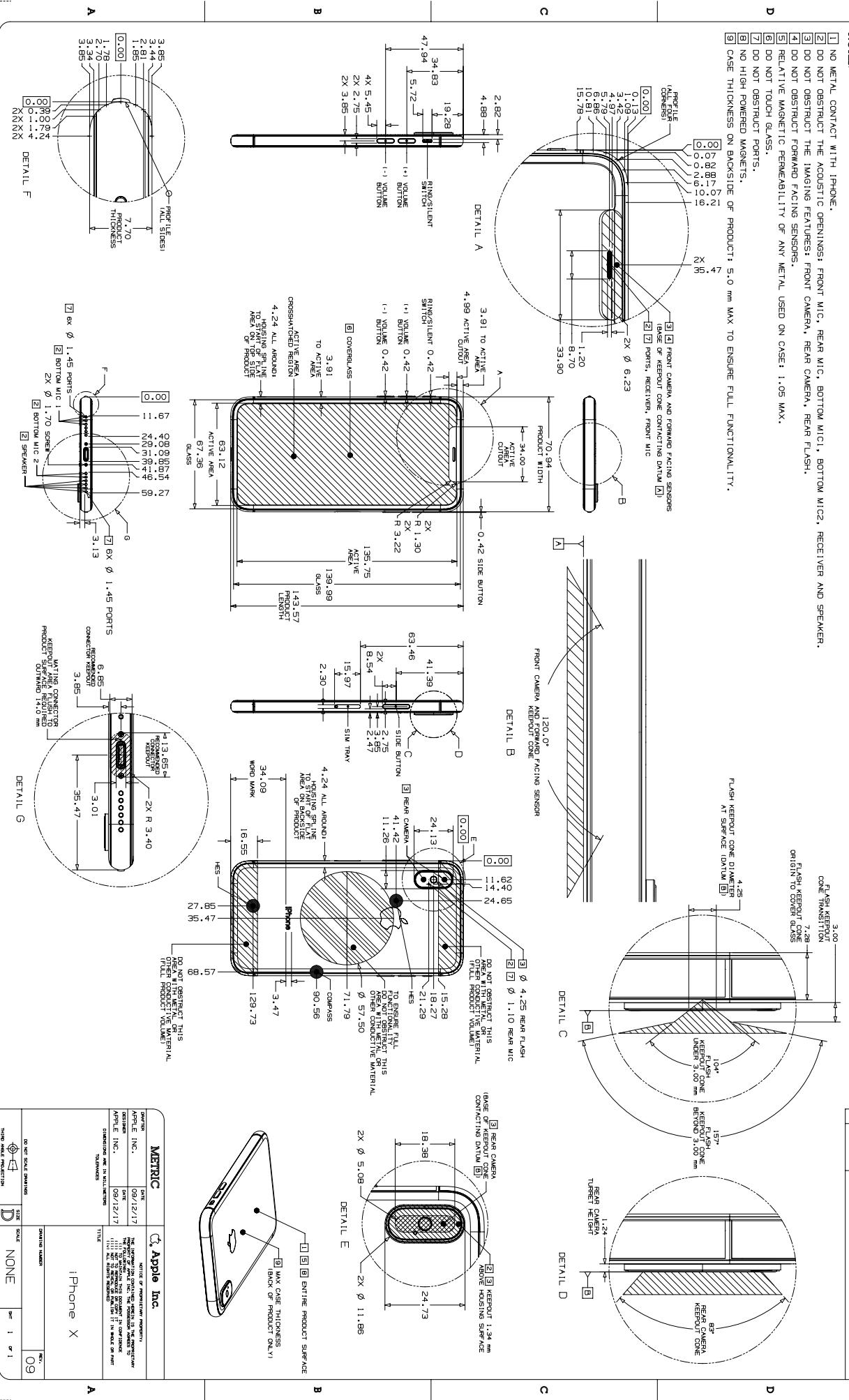

| REV | ECO | DESCRIPTION OF REVISION |
|-----|-----|-------------------------|
| 1 | | |
| 2 | | |
| 3 | | |
| 4 | | |

| DATE | BY | DESCRIPTION |
|----------|----|-------------------------|
| 09/12/17 | | APPROVAL FOR PRODUCTION |
| 09/12/17 | | APPROVAL FOR PRODUCTION |
| 09/12/17 | | APPROVAL FOR PRODUCTION |

| DATE | BY | DESCRIPTION |
|----------|----|-------------------------|
| 09/12/17 | | APPROVAL FOR PRODUCTION |
| 09/12/17 | | APPROVAL FOR PRODUCTION |
| 09/12/17 | | APPROVAL FOR PRODUCTION |

| DATE | BY | DESCRIPTION |
|----------|----|-------------------------|
| 09/12/17 | | APPROVAL FOR PRODUCTION |
| 09/12/17 | | APPROVAL FOR PRODUCTION |
| 09/12/17 | | APPROVAL FOR PRODUCTION |

| DATE | BY | DESCRIPTION |
|----------|----|-------------------------|
| 09/12/17 | | APPROVAL FOR PRODUCTION |
| 09/12/17 | | APPROVAL FOR PRODUCTION |
| 09/12/17 | | APPROVAL FOR PRODUCTION |

NOTES:

- 1 NO METAL CONTACT WITH IPHONE.
- 2 DO NOT OBSTRUCT THE ACOUSTIC OPENINGS; FRONT MIC, REAR MIC, BOTTOM MIC2, RECEIVER, AND SPEAKER.
- 3 DO NOT OBSTRUCT THE IMAGING FEATURES: FRONT CAMERA, REAR CAMERA, REAR FLASH.
- 4 DO NOT OBSTRUCT THE PROXIMITY SENSOR OR AMBIENT LIGHT SENSOR (ALS).
- 5 DO NOT TOUCH GLASS.
- 6 DO NOT OBSTRUCT PORTS.
- 7 NO HIGH POWERED MAGNETS.
- 8 RELATIVE MAGNETIC PERMEABILITY OF ANY METAL USED ON CASE: 1.05 MAX.
- 9 CASE THICKNESS ON BACKSIDE OF PRODUCT: 5.0 mm MAX TO ENSURE FULL FUNCTIONALITY.

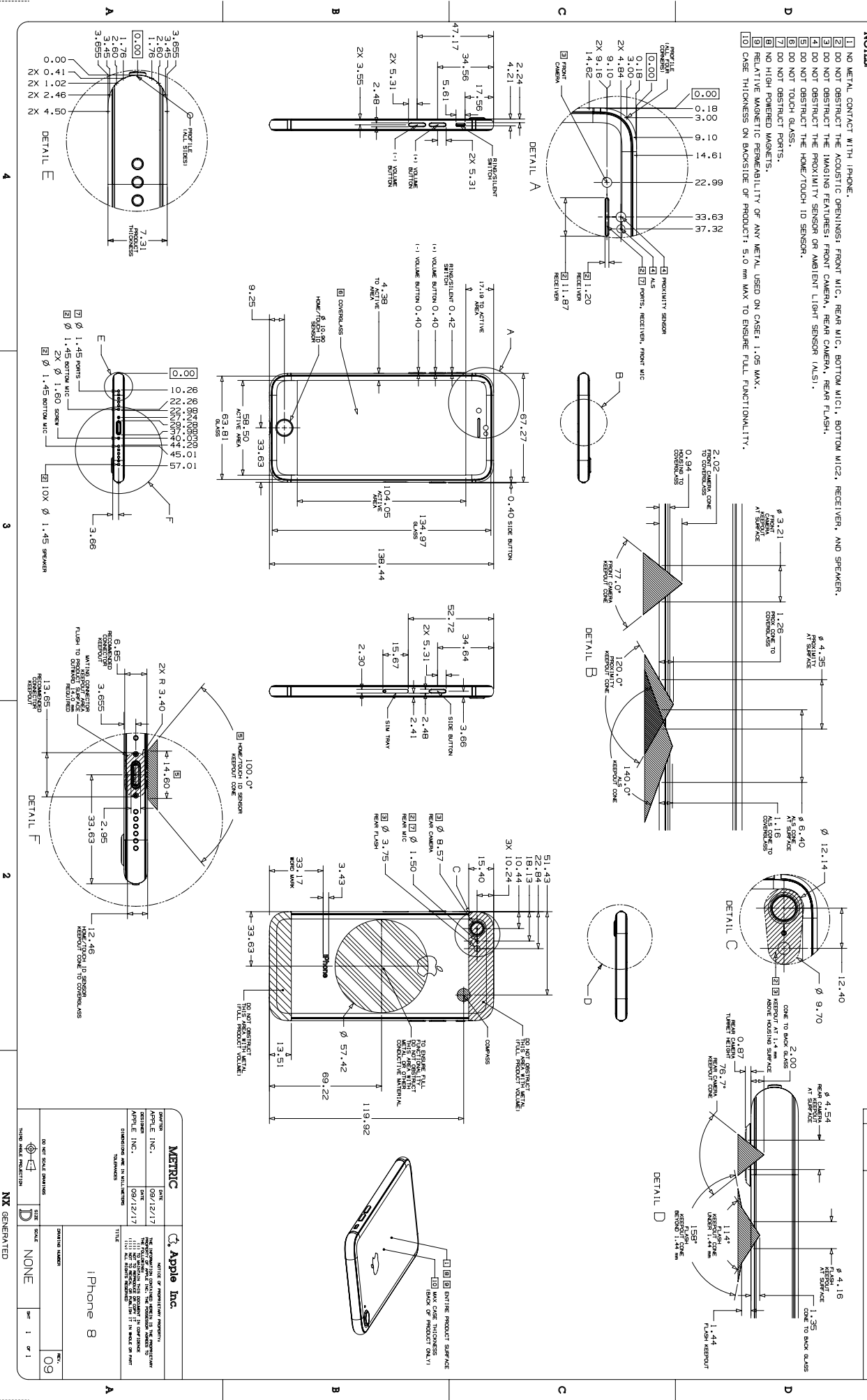

| REV | ECO | DESCRIPTION OF REVISION |
|-----|-----|-------------------------|
| 1 | | |

| DATE | BY | DESCRIPTION |
|----------|----|--|
| 09/12/17 | | APPROVED FOR THE DESIGN OF THE PRODUCT |
| 09/12/17 | | APPROVED FOR THE DESIGN OF THE PRODUCT |

| DATE | BY | DESCRIPTION |
|----------|----|--|
| 09/12/17 | | APPROVED FOR THE DESIGN OF THE PRODUCT |
| 09/12/17 | | APPROVED FOR THE DESIGN OF THE PRODUCT |

| DATE | BY | DESCRIPTION |
|----------|----|--|
| 09/12/17 | | APPROVED FOR THE DESIGN OF THE PRODUCT |
| 09/12/17 | | APPROVED FOR THE DESIGN OF THE PRODUCT |

| DATE | BY | DESCRIPTION |
|----------|----|--|
| 09/12/17 | | APPROVED FOR THE DESIGN OF THE PRODUCT |
| 09/12/17 | | APPROVED FOR THE DESIGN OF THE PRODUCT |

| DATE | BY | DESCRIPTION |
|----------|----|--|
| 09/12/17 | | APPROVED FOR THE DESIGN OF THE PRODUCT |
| 09/12/17 | | APPROVED FOR THE DESIGN OF THE PRODUCT |

| DATE | BY | DESCRIPTION |
|----------|----|--|
| 09/12/17 | | APPROVED FOR THE DESIGN OF THE PRODUCT |
| 09/12/17 | | APPROVED FOR THE DESIGN OF THE PRODUCT |

| DATE | BY | DESCRIPTION |
|----------|----|--|
| 09/12/17 | | APPROVED FOR THE DESIGN OF THE PRODUCT |
| 09/12/17 | | APPROVED FOR THE DESIGN OF THE PRODUCT |

NOTES:

- 1 NO METAL CONTACT WITH IPHONE.
- 2 DO NOT OBSTRUCT THE ACOUSTIC OPENINGS; FRONT MIC, REAR MIC, BOTTOM MIC1, BOTTOM MIC2, RECEIVER AND SPEAKER.
- 3 DO NOT OBSTRUCT THE IMAGING FEATURES: FRONT CAMERA, REAR CAMERA, REAR FLASH.
- 4 DO NOT OBSTRUCT THE PROXIMITY SENSOR OR AMBIENT LIGHT SENSOR (ALS).
- 5 DO NOT OBSTRUCT THE HOME BUTTON.
- 6 DO NOT TOUCH GLASS.
- 7 DO NOT OBSTRUCT ALL PORTS.
- 8 NO HIGH POWERED MAGNETS, ENTIRE PRODUCT SURFACE.

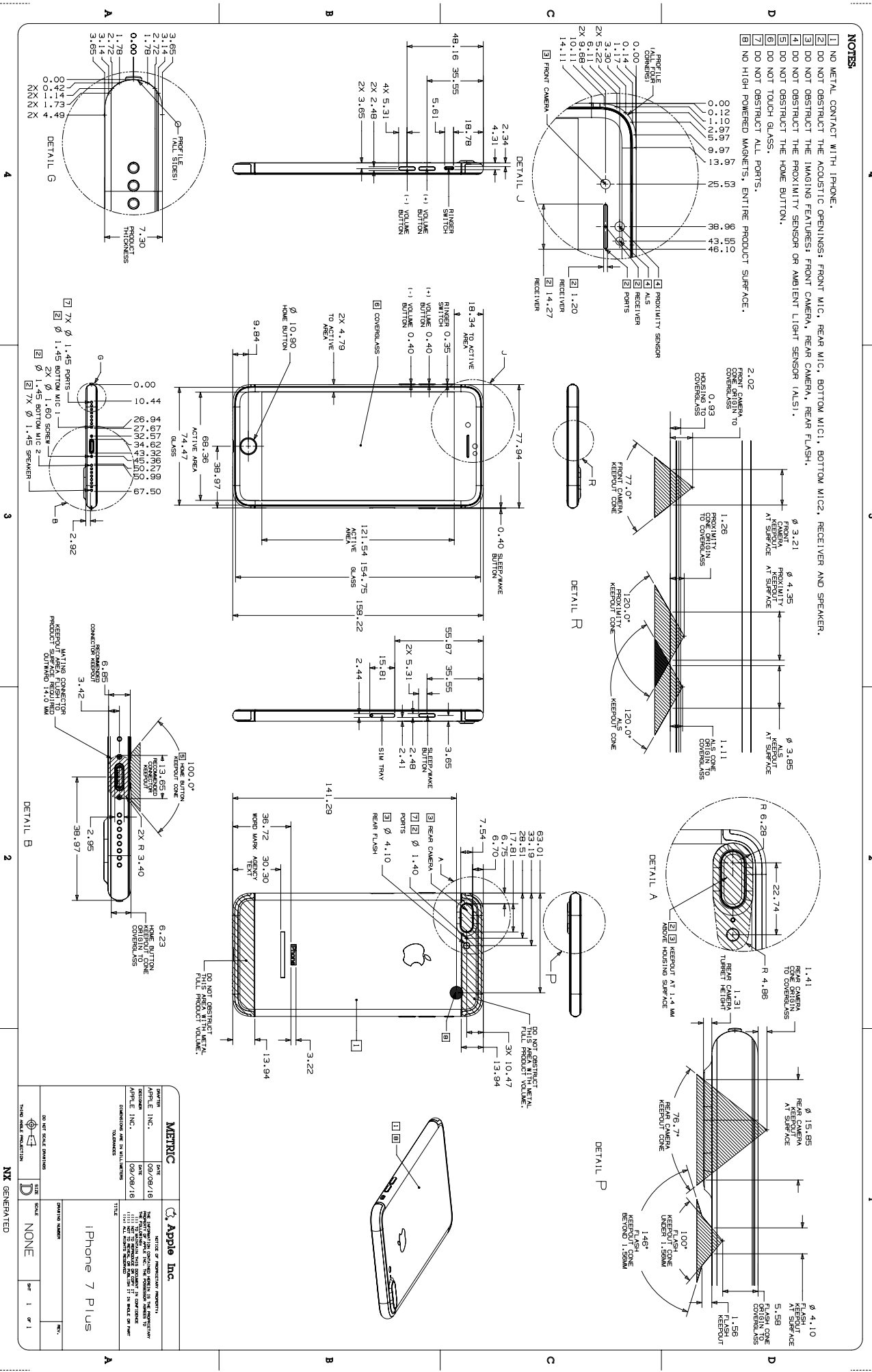

| | | | | | |
|----------------------------|------|----------------|----------|-------------------|------|
| | | | | Apple Inc. | |
| METRIC | DATE | 09/08/18 | REVISION | 09/08/18 | DATE |
| APPL E INC. | DATE | 09/08/18 | REVISION | 09/08/18 | DATE |
| APPL E INC. | DATE | 09/08/18 | REVISION | 09/08/18 | DATE |
| DRAWING LINE STYLE NUMBERS | | DRAWING NUMBER | | REV. | |
| NONE | | NONE | | 1 OF 1 | |
| iPhone 7 Plus | | | | | |

NOTES

- 1 NO METAL CONTACT WITH IPHONE.
- 2 DO NOT OBSTRUCT THE ACOUSTIC OPENINGS: FRONT MIC, REAR MIC, BOTTOM MIC1, BOTTOM MIC2, RECEIVER, AND SPEAKER.
- 3 DO NOT OBSTRUCT THE IMAGING FEATURES: FRONT CAMERA, REAR CAMERA, REAR FLASH.
- 4 DO NOT OBSTRUCT THE PROXIMITY SENSOR OR AMBIENT LIGHT SENSOR (ALS).
- 5 DO NOT TOUCH GLASS.
- 6 DO NOT OBSTRUCT THE HOME BUTTON.
- 7 DO NOT OBSTRUCT PORTS.
- 8 NO HIGH POWERED MAGNETS, ENTIRE PRODUCT SURFACE.

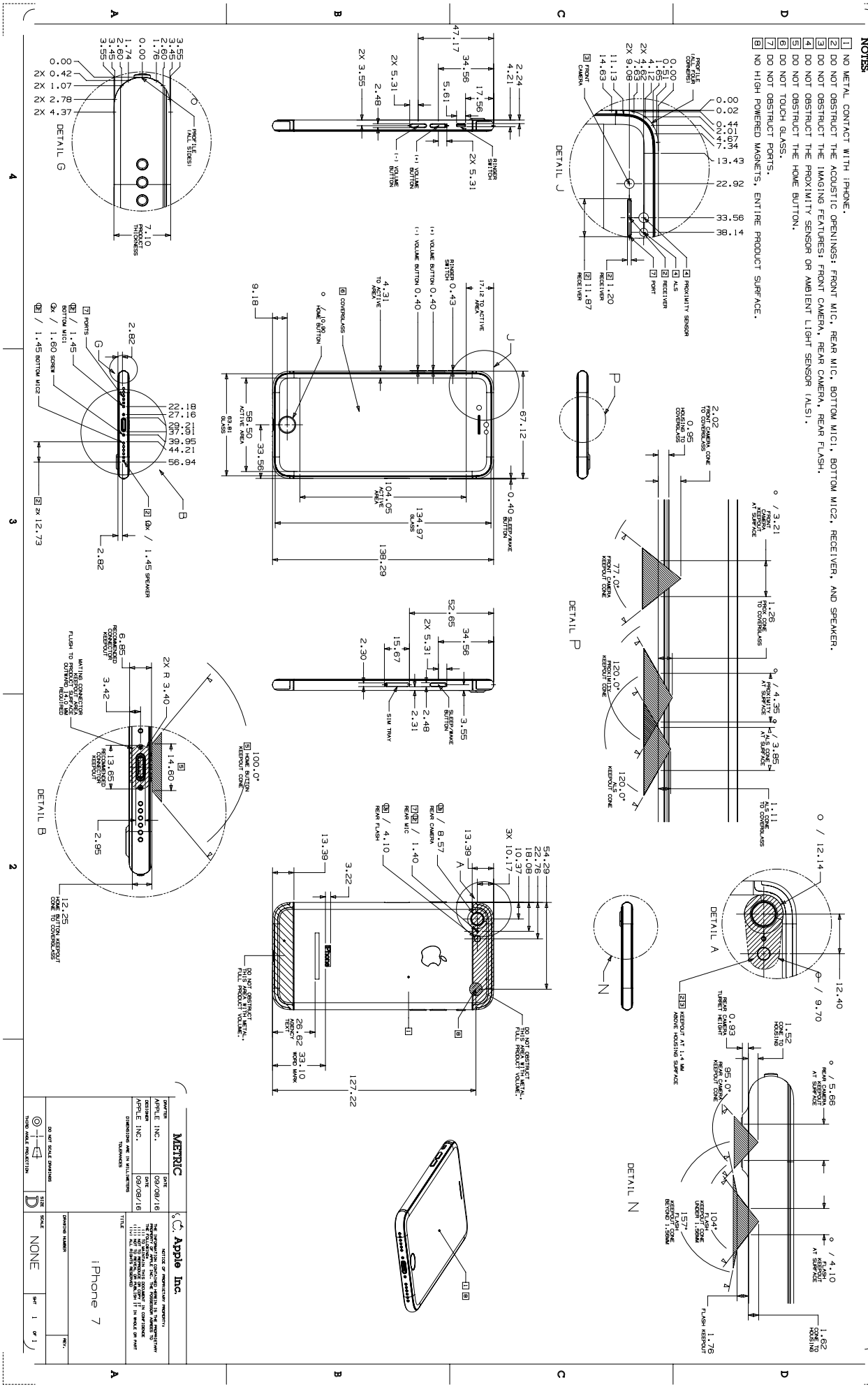

| METRIC | | Apple Inc. | |
|---|----------|-------------|----------|
| DATE | 09/09/18 | DATE | 09/09/18 |
| APPROVED BY | 09/09/18 | APPROVED BY | 09/09/18 |
| DESIGNED BY | 09/09/18 | DESIGNED BY | 09/09/18 |
| <p>THIS DRAWING IS THE PROPERTY OF APPLE INC. IT IS TO BE USED FOR THE DESIGN AND MANUFACTURE OF THE PRODUCT DESCRIBED HEREIN. IT IS TO BE KEPT IN CONFIDENCE AND NOT TO BE DISCLOSED TO ANY OTHER PARTY WITHOUT THE WRITTEN PERMISSION OF APPLE INC.</p> | | | |
| <p>Apple Inc. is a registered trademark of Apple Inc. All other trademarks are the property of their respective owners.</p> | | | |
| <p>iPhone 7</p> | | | |
| <p>DO NOT SCALE DRAWINGS</p> | | | |
| SCALE | NONE | SHEET | 1 OF 1 |

40.21 iPhone 6s Plus

NOTES:

- 1 NO METAL CONTACT WITH ANY IPHONE METAL.
- 2 DO NOT OBSTRUCT THE ACOUSTIC OPENINGS: FRONT MIC, REAR MIC, BOTTOM MIC1, BOTTOM MIC2, RECEIVER AND SPEAKER.
- 3 DO NOT OBSTRUCT THE IMAGING FEATURES: FRONT CAMERA, REAR CAMERA, REAR FLASH.
- 4 DO NOT OBSTRUCT THE PROXIMITY SENSOR OR AMBIENT LIGHT SENSOR (ALS).
- 5 DO NOT OBSTRUCT THE HOME BUTTON.
- 6 DO NOT TOUCH GLASS.

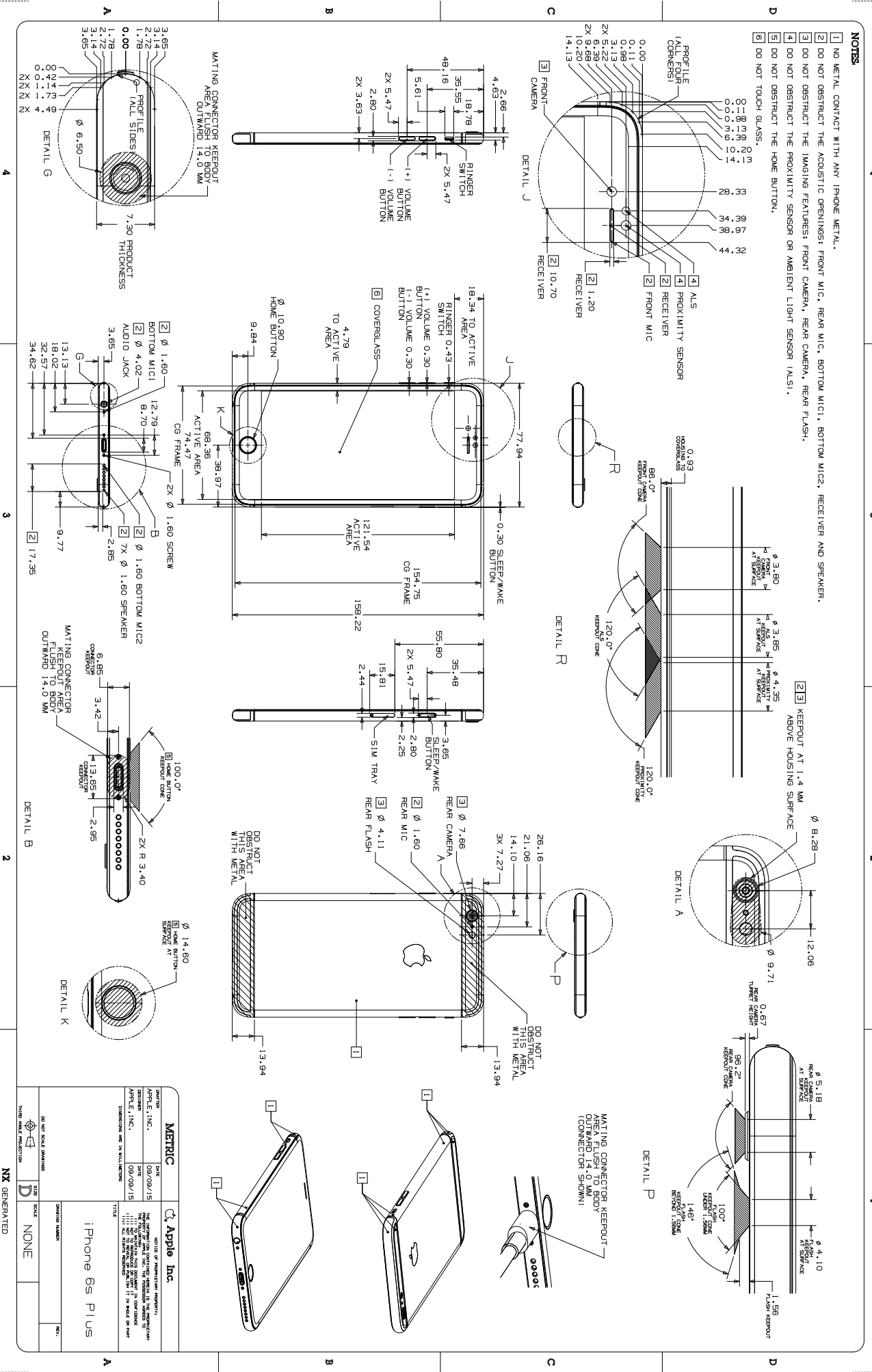

NOTES:

- 1 NO METAL CONTACT WITH ANY IPHONE METAL.
- 2 DO NOT OBSTRUCT THE ACOUSTIC OPENINGS: REAR MIC, REAR MIC2, BOTTOM MIC1, BOTTOM MIC2, RECEIVER, AND SPEAKER.
- 3 DO NOT OBSTRUCT THE IMAGING FEATURES: FRONT CAMERA, REAR CAMERA, REAR FLASH.
- 4 DO NOT OBSTRUCT THE PROXIMITY SENSOR OR AMBIENT LIGHT SENSOR (ALS).
- 5 DO NOT OBSTRUCT THE HOME BUTTON.
- 6 DO NOT TOUCH GLASS.

23 KEEPCUT AT 1.4 MM ABOVE HOUSING SURFACE

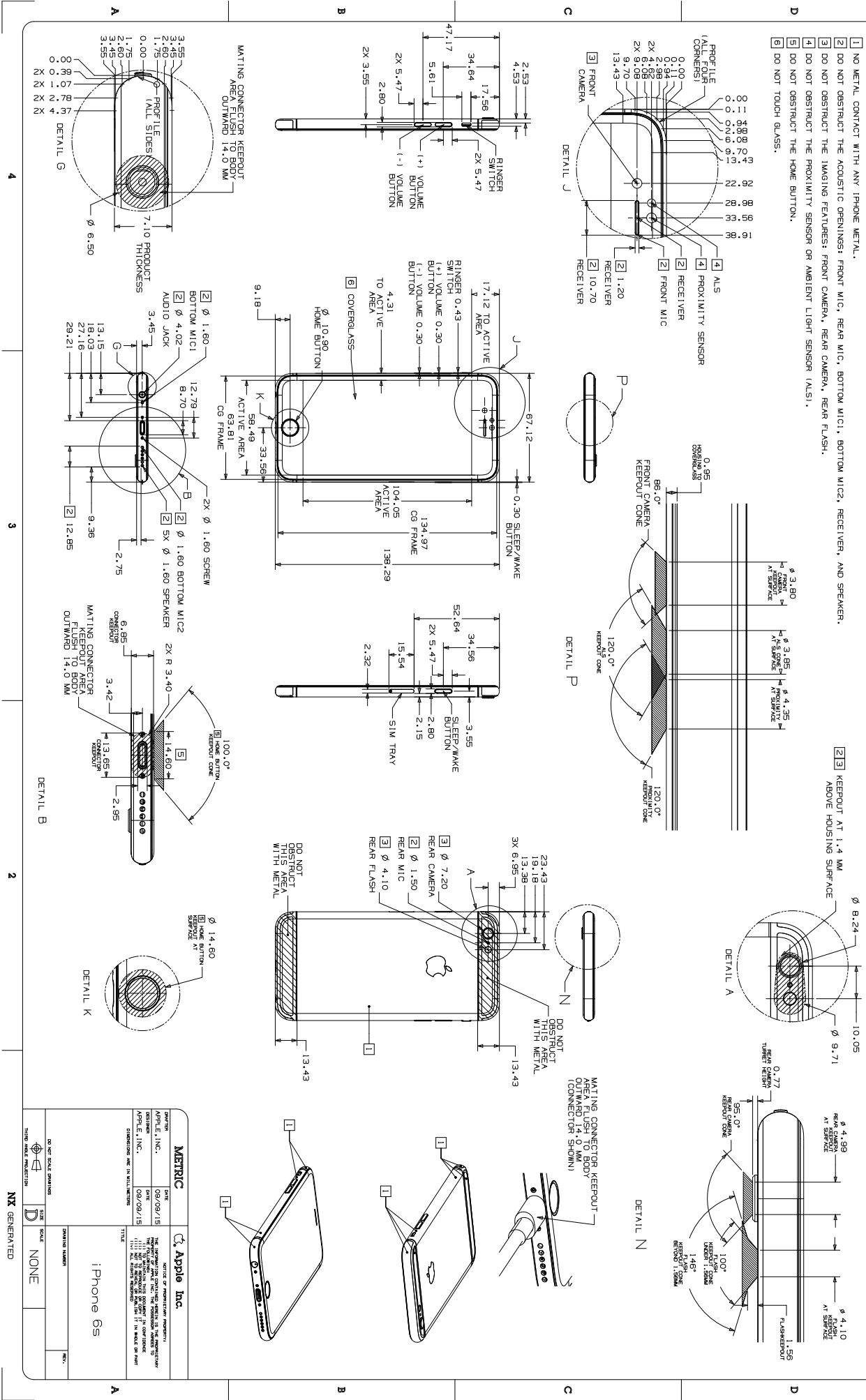

| METRIC | | Apple Inc. | |
|---|------------|-------------|------------|
| DATE | 09/09/15 | DESIGNED BY | Apple Inc. |
| APPROVED BY | Apple Inc. | DATE | 09/09/15 |
| <p>THIS DRAWING IS THE PROPERTY OF APPLE INC. IT IS TO BE USED FOR THE DESIGN AND MANUFACTURE OF THE PRODUCT SPECIFICALLY IDENTIFIED IN THE TITLE. IT IS TO BE KEPT IN CONFIDENTIALITY AND NOT TO BE REPRODUCED OR TRANSMITTED IN ANY FORM OR BY ANY MEANS, ELECTRONIC OR MECHANICAL, INCLUDING PHOTOCOPYING, RECORDING, OR BY ANY INFORMATION STORAGE AND RETRIEVAL SYSTEM, WITHOUT THE WRITTEN PERMISSION OF APPLE INC.</p> | | | |
| DRAWING NUMBER | | TITLE | |
| | | iPhone 6s | |
| DO NOT SCALE DRAWINGS | | SCALE | |
| NONE | | NONE | |
| DRAWING MADE | | DATE | |
| NX GENERATED | | | |

40.25 iPhone 5s & iPhone SE

- *NOTES
- 1 NO METAL CONTACT WITH IPHONE METAL.
 - 2 DO NOT OBSTRUCT THE ACOUSTIC OPENINGS: FRONT MIC, REAR MIC, EARPIECE, AND SPEAKER.
 - 3 DO NOT OBSTRUCT THE IMAGING FEATURES: FRONT CAMERA, REAR CAMERA, REAR FLASH.
 - 4 DO NOT OBSTRUCT THE PROXIMITY SENSOR OR ALS (AMBIENT LIGHT SENSOR).
 - 5 DO NOT OBSTRUCT THE HOME BUTTON.

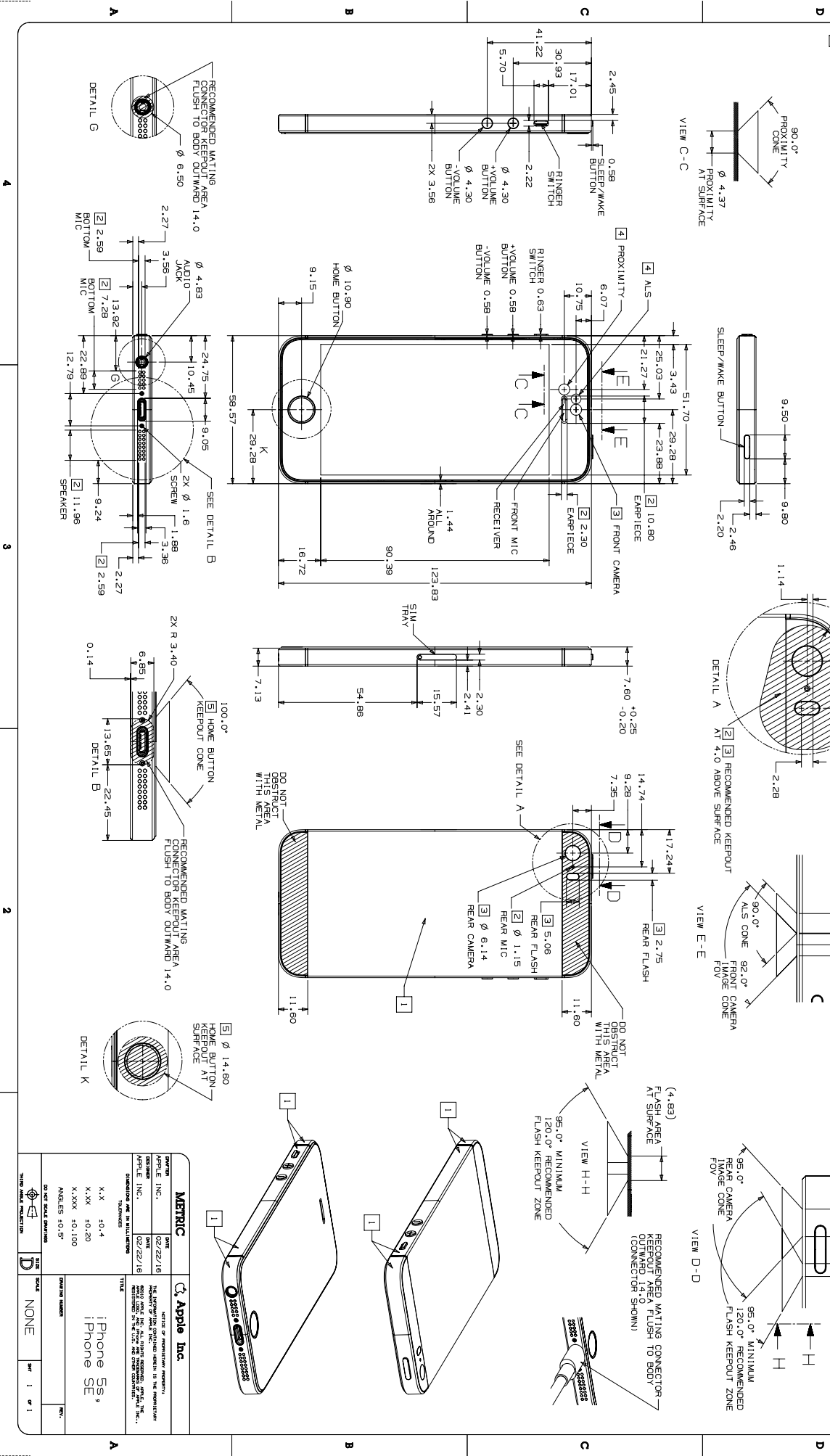

| METRIC | | DATE | |
|---------------------------------|----------|-----------------------|----------|
| APPLICABLE INC. | 02/22/16 | DATE | 02/22/16 |
| APPLICABLE INC. | 02/22/16 | DATE | 02/22/16 |
| DRAWING MADE BY: [REDACTED] | | | |
| DRAWING CHECKED BY: [REDACTED] | | | |
| DRAWING APPROVED BY: [REDACTED] | | | |
| DRAWING REVISION | | | |
| TITLE | | i!Phone 5s, iPhone SE | |
| SCALE | | NONE | |
| SHEET | | 1 OF 1 | |

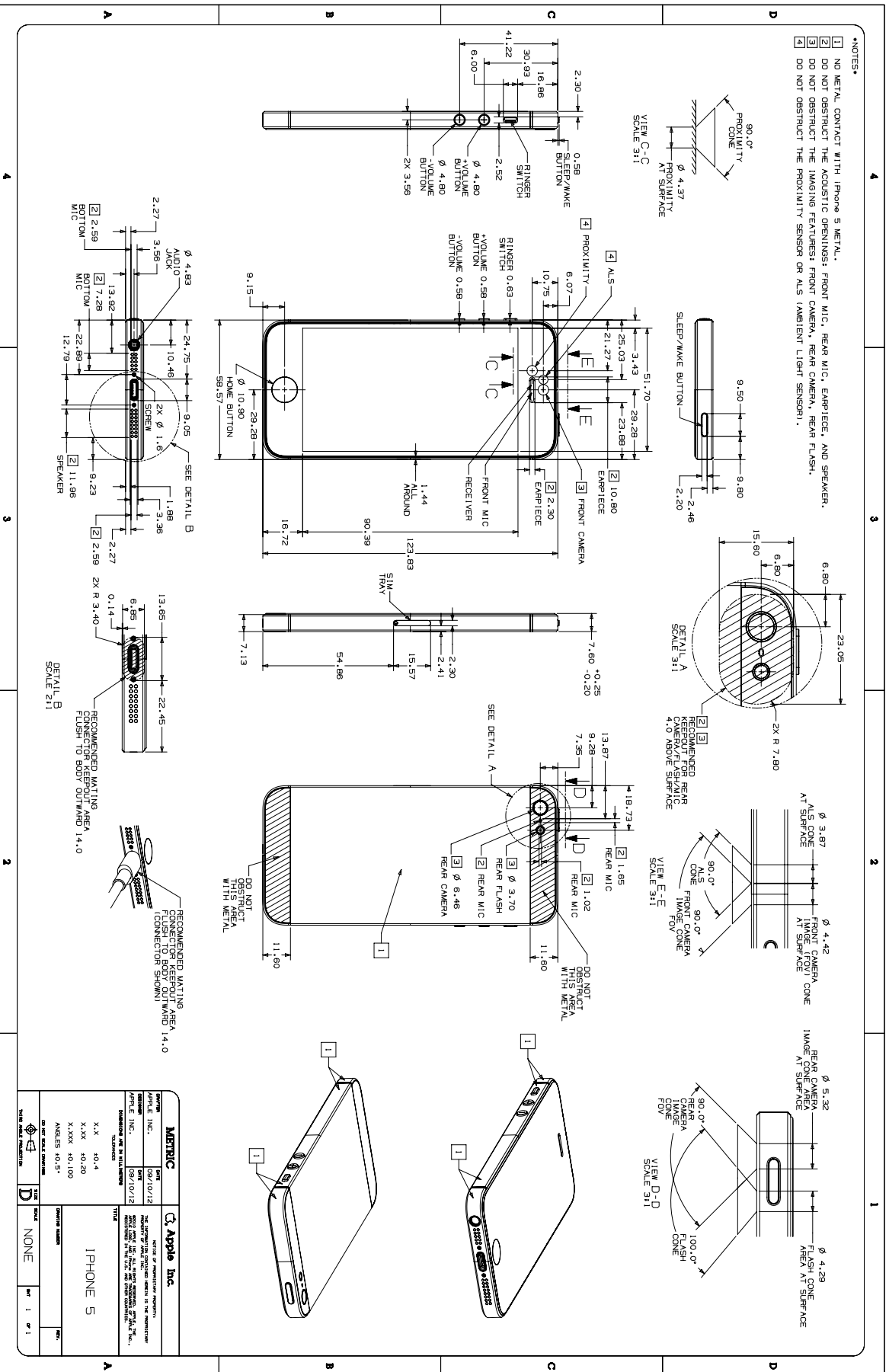

40.29 iPad Air (4th generation) 2 of 5

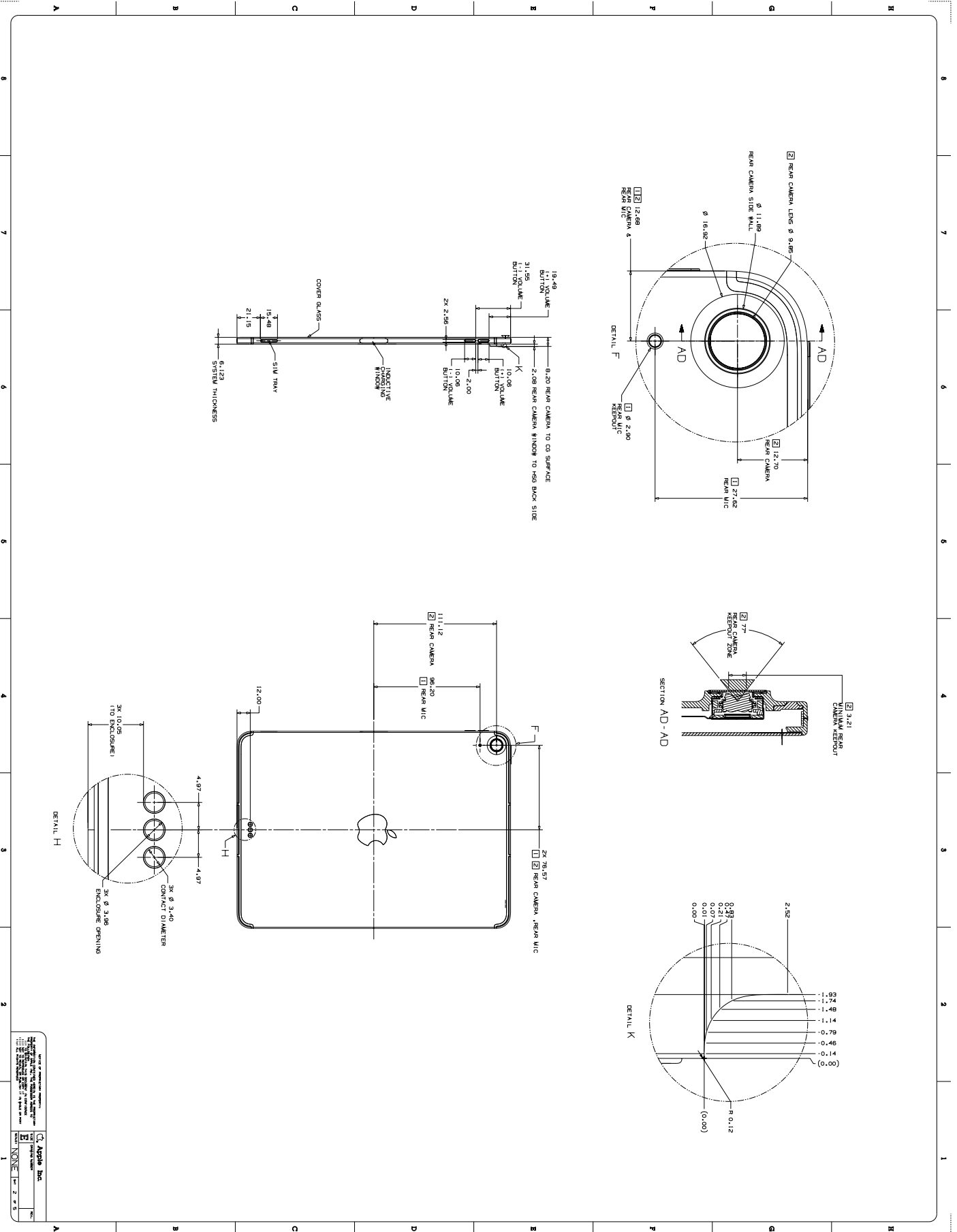

MAGNET DETAIL

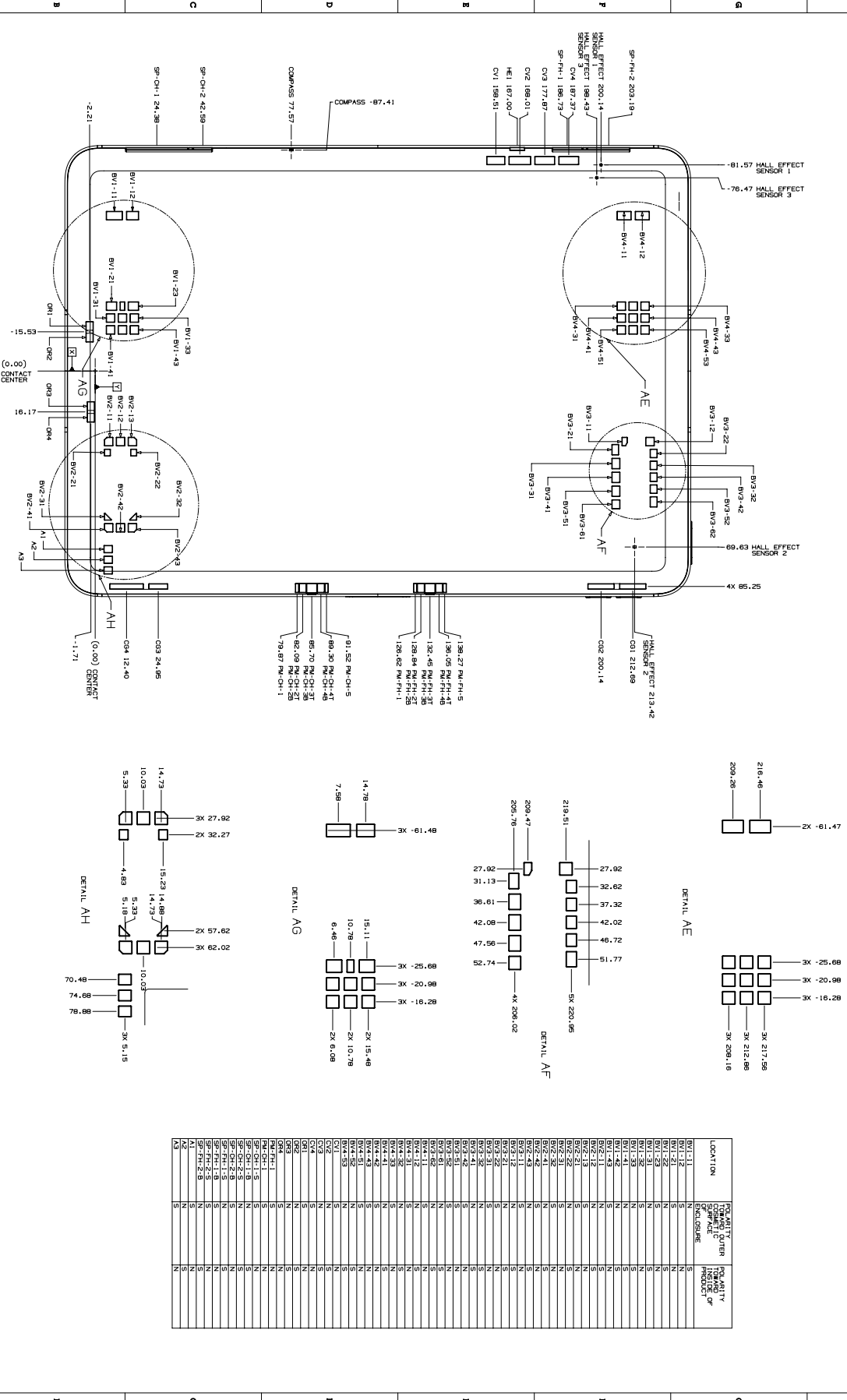

| LOCATION | PART NUMBER | REVISION | QUANTITY | UNIT | DESCRIPTION |
|----------|-----------------------------|----------|----------|------|-------------|
| BV1-11 | 81.57 HALL EFFECT SENSOR 1 | | 1 | | |
| BV1-12 | 76.47 HALL EFFECT SENSOR 3 | | 1 | | |
| BV1-13 | 69.63 HALL EFFECT SENSOR 4 | | 1 | | |
| BV1-14 | 213.42 HALL EFFECT SENSOR 2 | | 1 | | |
| BV1-15 | 219.51 HALL EFFECT SENSOR 5 | | 1 | | |
| BV1-16 | 209.47 HALL EFFECT SENSOR 6 | | 1 | | |
| BV1-17 | 209.76 HALL EFFECT SENSOR 7 | | 1 | | |
| BV1-18 | 138.27 PM-FH-5 | | 1 | | |
| BV1-19 | 138.05 PM-FH-4T | | 1 | | |
| BV1-20 | 132.46 PM-FH-3T | | 1 | | |
| BV1-21 | 128.84 PM-FH-2B | | 1 | | |
| BV1-22 | 128.62 PM-FH-1 | | 1 | | |
| BV1-23 | 91.52 PM-CH-5 | | 1 | | |
| BV1-24 | 89.30 PM-CH-4T | | 1 | | |
| BV1-25 | 85.70 PM-CH-3T | | 1 | | |
| BV1-26 | 82.09 PM-CH-2B | | 1 | | |
| BV1-27 | 79.87 PM-CH-1 | | 1 | | |
| BV1-28 | 14.79 | | 1 | | |
| BV1-29 | 10.03 | | 1 | | |
| BV1-30 | 5.33 | | 1 | | |
| BV1-31 | 15.23 | | 1 | | |
| BV1-32 | 14.88 | | 1 | | |
| BV1-33 | 5.33 | | 1 | | |
| BV1-34 | 14.73 | | 1 | | |
| BV1-35 | 10.03 | | 1 | | |
| BV1-36 | 5.33 | | 1 | | |
| BV1-37 | 15.23 | | 1 | | |
| BV1-38 | 14.88 | | 1 | | |
| BV1-39 | 5.33 | | 1 | | |
| BV1-40 | 14.73 | | 1 | | |
| BV1-41 | 10.03 | | 1 | | |
| BV1-42 | 5.33 | | 1 | | |
| BV1-43 | 15.23 | | 1 | | |
| BV1-44 | 14.88 | | 1 | | |
| BV1-45 | 5.33 | | 1 | | |
| BV1-46 | 14.73 | | 1 | | |
| BV1-47 | 10.03 | | 1 | | |
| BV1-48 | 5.33 | | 1 | | |
| BV1-49 | 15.23 | | 1 | | |
| BV1-50 | 14.88 | | 1 | | |
| BV1-51 | 5.33 | | 1 | | |
| BV1-52 | 14.73 | | 1 | | |
| BV1-53 | 10.03 | | 1 | | |
| BV1-54 | 5.33 | | 1 | | |
| BV1-55 | 15.23 | | 1 | | |
| BV1-56 | 14.88 | | 1 | | |
| BV1-57 | 5.33 | | 1 | | |
| BV1-58 | 14.73 | | 1 | | |
| BV1-59 | 10.03 | | 1 | | |
| BV1-60 | 5.33 | | 1 | | |
| BV1-61 | 15.23 | | 1 | | |
| BV1-62 | 14.88 | | 1 | | |
| BV1-63 | 5.33 | | 1 | | |
| BV1-64 | 14.73 | | 1 | | |
| BV1-65 | 10.03 | | 1 | | |
| BV1-66 | 5.33 | | 1 | | |
| BV1-67 | 15.23 | | 1 | | |
| BV1-68 | 14.88 | | 1 | | |
| BV1-69 | 5.33 | | 1 | | |
| BV1-70 | 14.73 | | 1 | | |
| BV1-71 | 10.03 | | 1 | | |
| BV1-72 | 5.33 | | 1 | | |
| BV1-73 | 15.23 | | 1 | | |
| BV1-74 | 14.88 | | 1 | | |
| BV1-75 | 5.33 | | 1 | | |
| BV1-76 | 14.73 | | 1 | | |
| BV1-77 | 10.03 | | 1 | | |
| BV1-78 | 5.33 | | 1 | | |
| BV1-79 | 15.23 | | 1 | | |
| BV1-80 | 14.88 | | 1 | | |
| BV1-81 | 5.33 | | 1 | | |
| BV1-82 | 14.73 | | 1 | | |
| BV1-83 | 10.03 | | 1 | | |
| BV1-84 | 5.33 | | 1 | | |
| BV1-85 | 15.23 | | 1 | | |
| BV1-86 | 14.88 | | 1 | | |
| BV1-87 | 5.33 | | 1 | | |
| BV1-88 | 14.73 | | 1 | | |
| BV1-89 | 10.03 | | 1 | | |
| BV1-90 | 5.33 | | 1 | | |
| BV1-91 | 15.23 | | 1 | | |
| BV1-92 | 14.88 | | 1 | | |
| BV1-93 | 5.33 | | 1 | | |
| BV1-94 | 14.73 | | 1 | | |
| BV1-95 | 10.03 | | 1 | | |
| BV1-96 | 5.33 | | 1 | | |
| BV1-97 | 15.23 | | 1 | | |
| BV1-98 | 14.88 | | 1 | | |
| BV1-99 | 5.33 | | 1 | | |
| BV1-100 | 14.73 | | 1 | | |

SECTION AND DETAIL INFORMATION

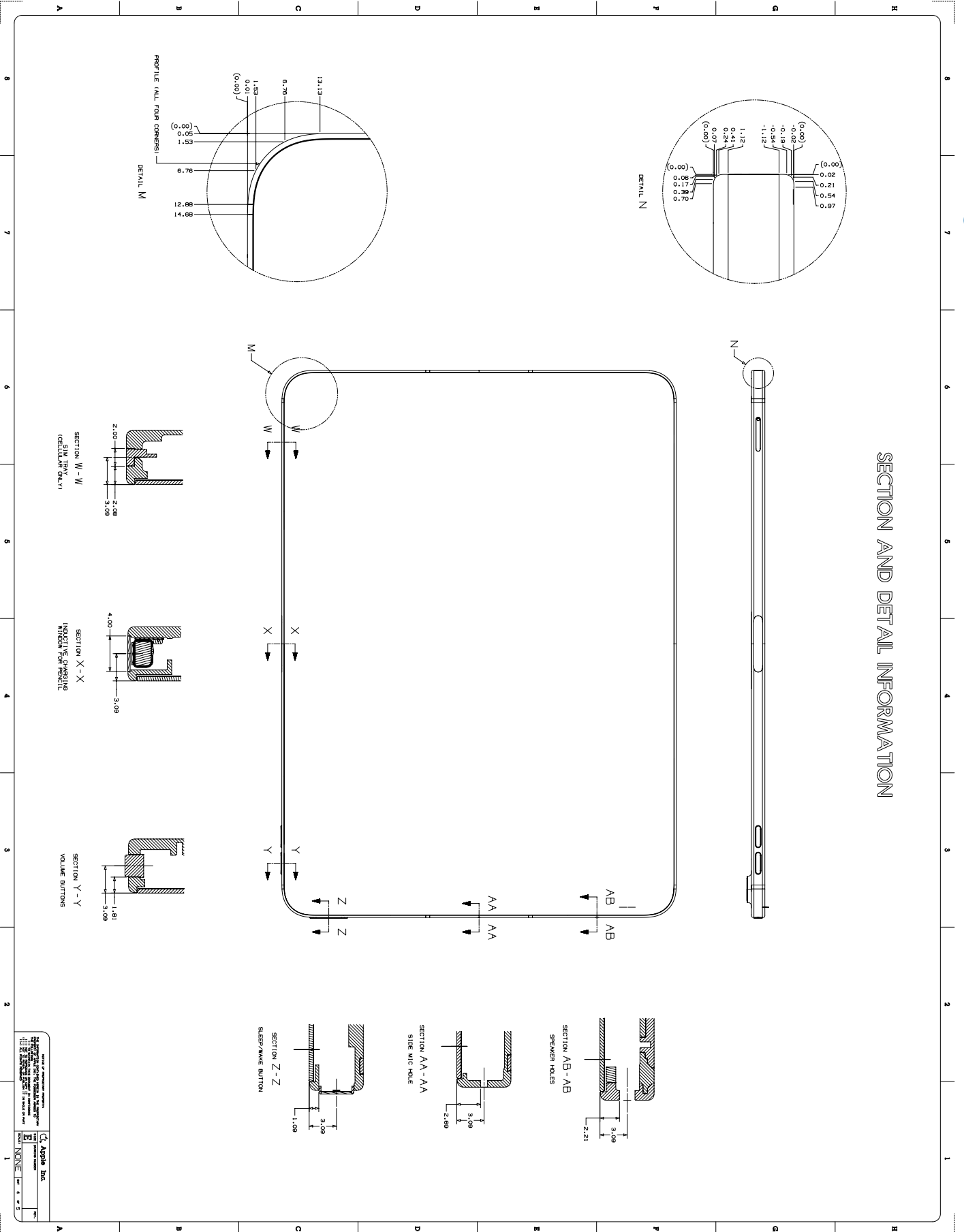

ANTENNA KEEPOUT

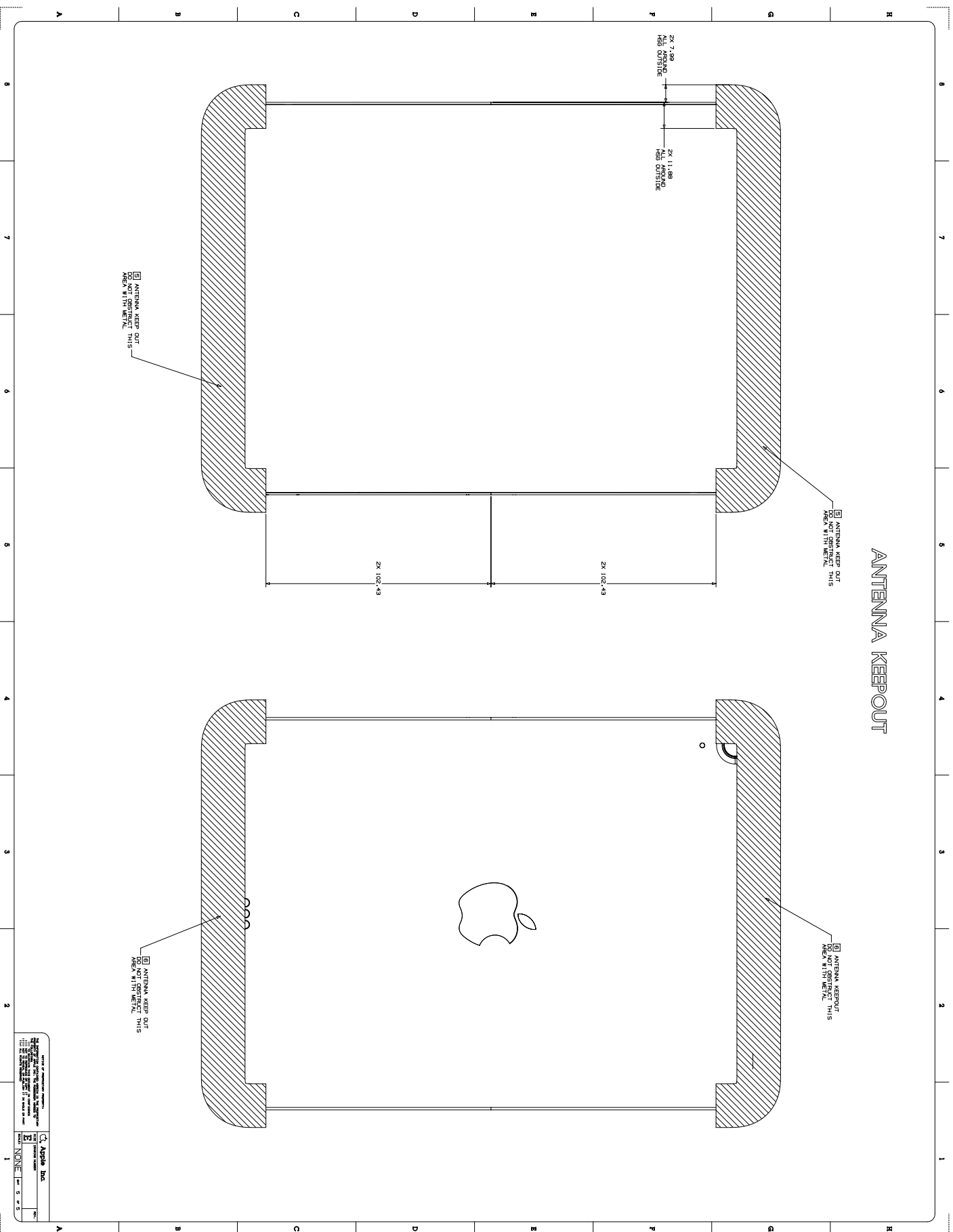

| | | |
|---|-------------------------------|--|
| <small> MODEL OF ANTENNA INFORMATION Model Name: 40.32 iPad Air (4th generation) Model Number: A2072 Model Name: 40.32 iPad Air (4th generation) Model Number: A2072 Model Name: 40.32 iPad Air (4th generation) Model Number: A2072 </small> | | <input checked="" type="checkbox"/> Apple Inc. |
| <input type="checkbox"/> None | <input type="checkbox"/> None | <input type="checkbox"/> None |

40.33 iPad Pro (12.9-inch) 4th Generation 1 of 5

- NOTES:** DIMENSIONS OPENINGS SPECIFIED
- DO NOT OBSTRUCT ACOUSTIC OPENINGS, SIDE MIC, FRONT MIC, REAR MIC, SPEAKERS
 - DO NOT OBSTRUCT REAR CAMERA, REAR FLASH, & REAR IR CAMERA
 - DO NOT OBSTRUCT REAR LIGHT SENSOR, AUTOMATICALLY, FRONT CAMERA & DOT PROJECTOR
 - DO NOT HAVE METAL CONTACT WITH DEVICE COVER GLASS

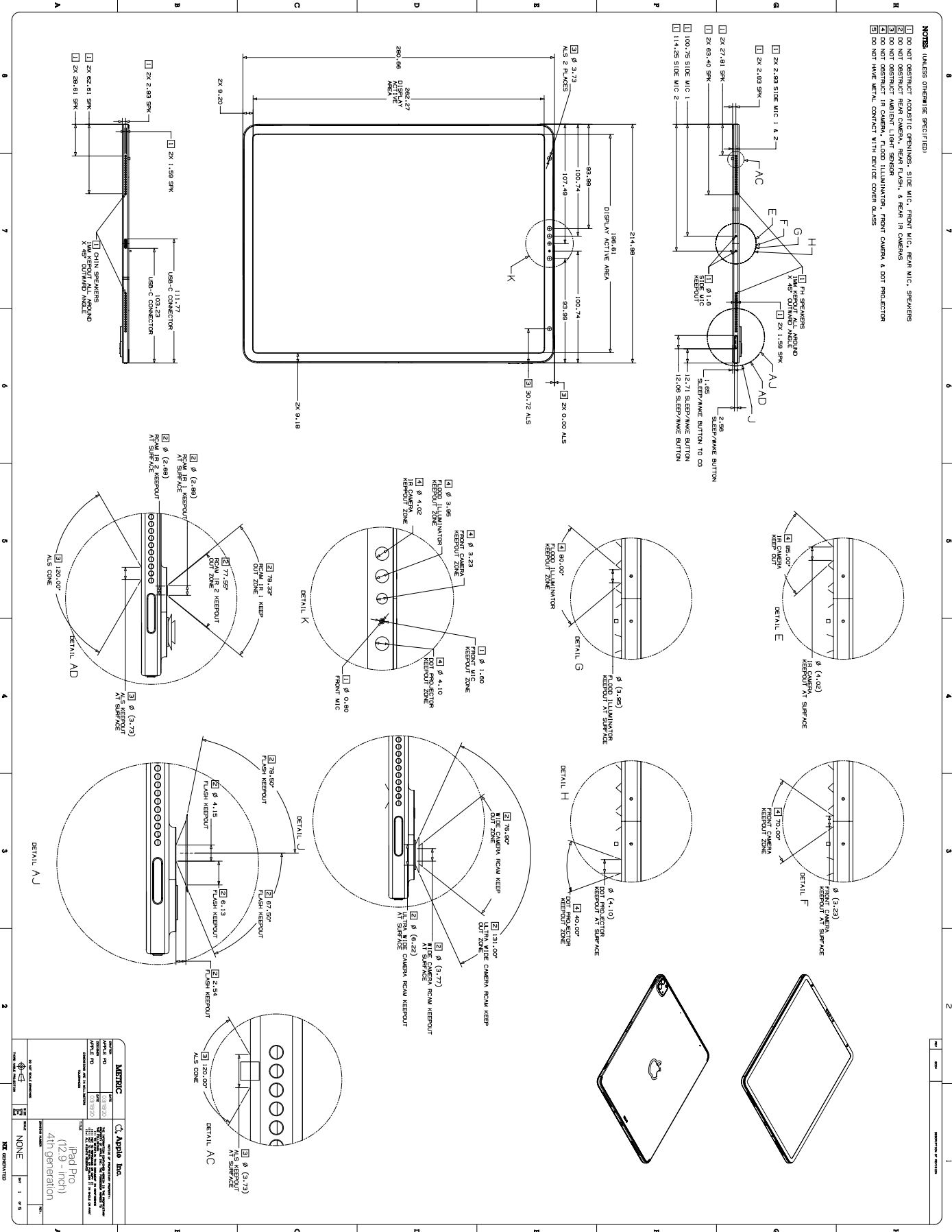

| METRIC | | Apple Inc. | |
|---------------------------------------|----------|--------------|------------|
| DATE | 10/10/20 | DESIGNER | Apple Inc. |
| REV | 1 | ENGINEER | Apple Inc. |
| PART NAME | | PART NUMBER | |
| iPad Pro (12.9 - inch) 4th generation | | 40.33 | |
| MATERIAL | | MATERIAL | |
| NONE | | NONE | |
| FINISH | | FINISH | |
| NONE | | NONE | |
| SCALE | | SCALE | |
| 1:1 | | 1:1 | |
| SHEET NUMBER | | SHEET NUMBER | |
| 1 OF 5 | | 1 OF 5 | |

MAGNET DETAIL

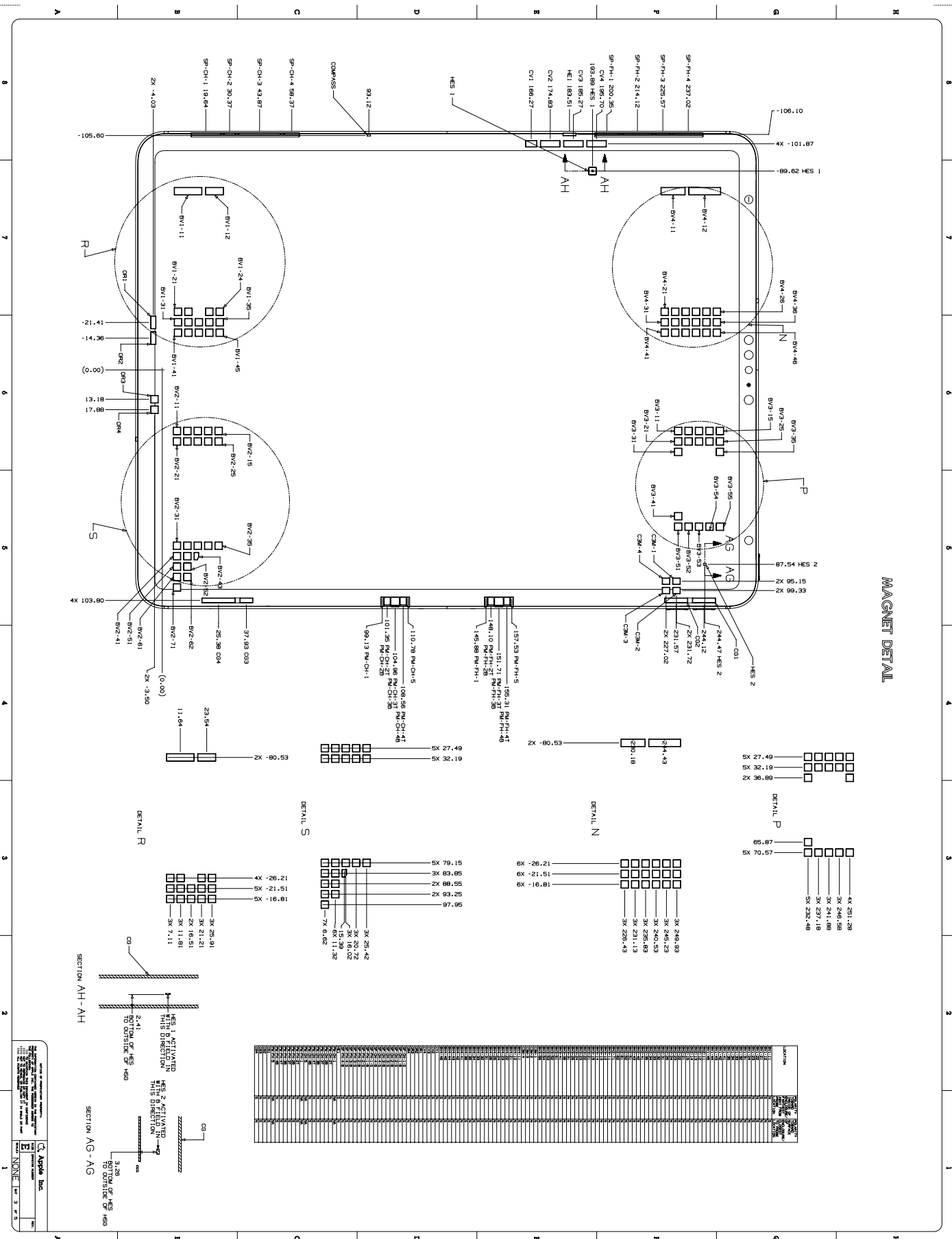

SECTION AG-AG
 SECTION AH-AH

AG-AG
 3.28
 BOTTOM OF HES 450

AH-AH
 2.41
 BOTTOM OF HES 450

HES 1 ACTIVATED
 THIS DIRECTION

HES 2 ACTIVATED
 THIS DIRECTION

Apple Inc.
 Copyright © 2020 Apple Inc. All Rights Reserved.

SECTION AND DETAIL INFORMATION

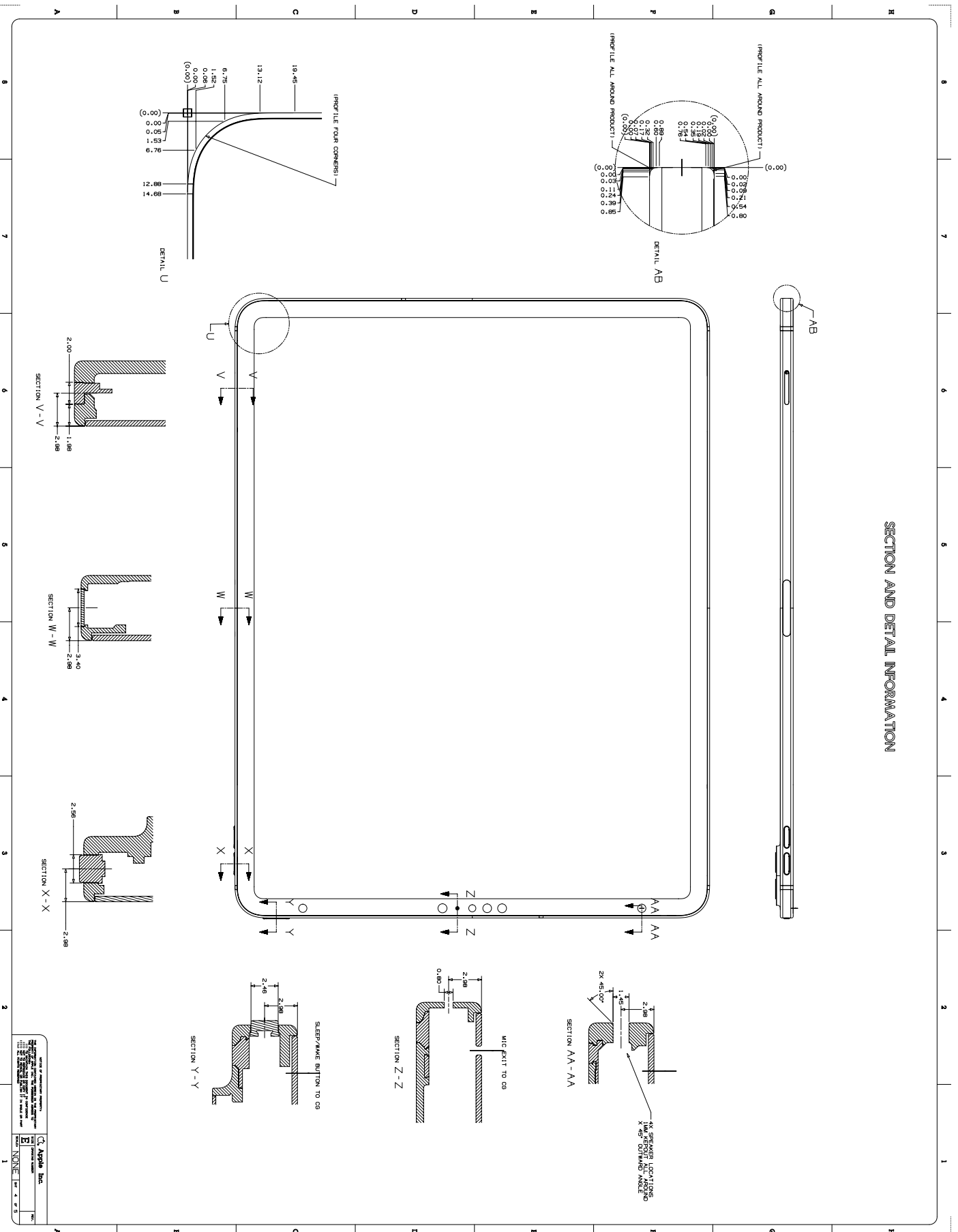

40.37 iPad Pro (12.9-inch) 4th Generation 5 of 5

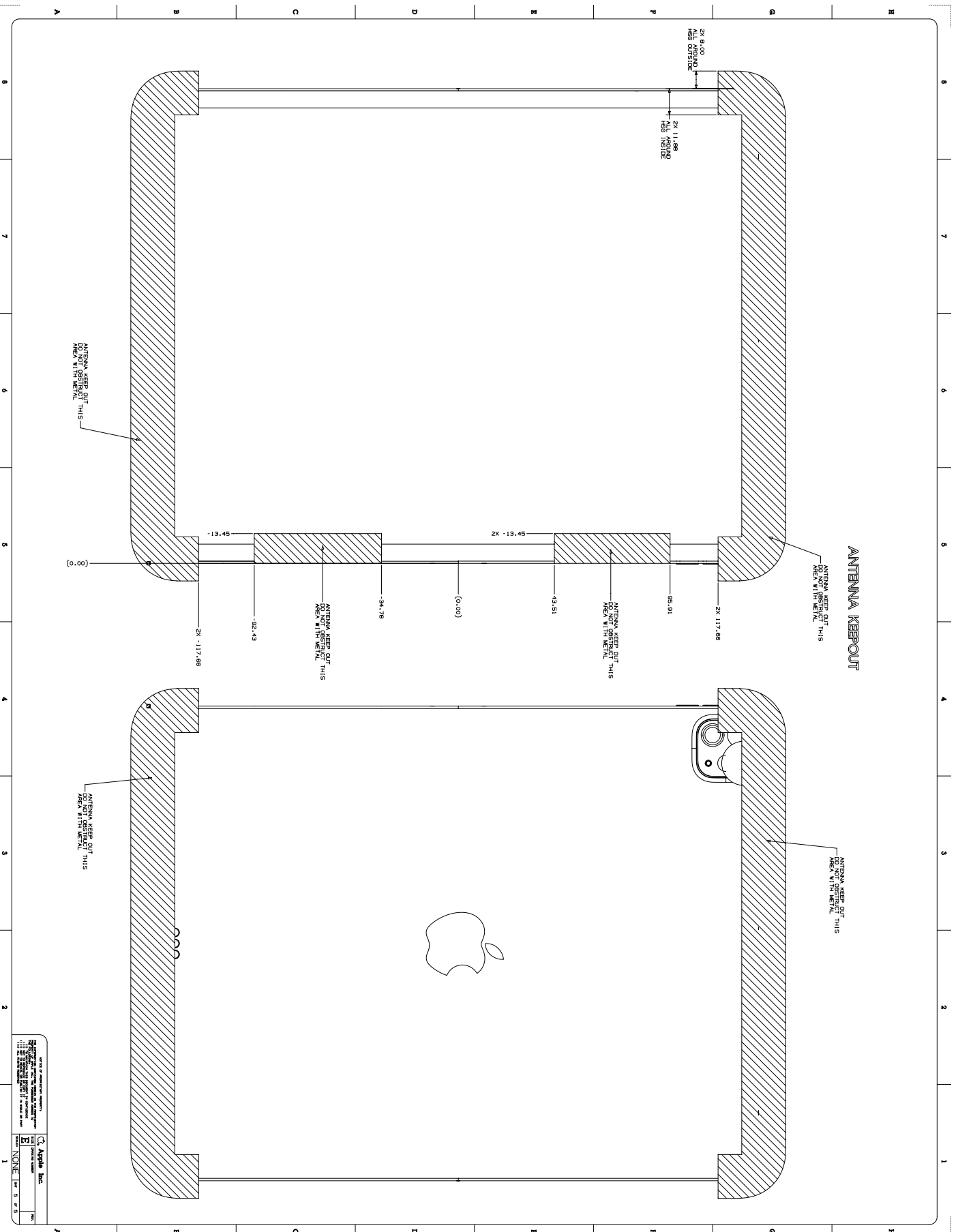

| | |
|----------------------|----------------------|
| Apple Inc. | |
| Model: A1708 | Part: 40.37 |
| Version: 1.0 | Revision: 1.0 |
| Created: 2020-10-16 | Modified: 2020-10-16 |
| Author: Apple Inc. | Checked: Apple Inc. |
| Approved: Apple Inc. | Released: Apple Inc. |

- NOTES:** UNLESS OTHERWISE SPECIFIED:
- 1 DO NOT OBSTRUCT ACOUSTIC OPENINGS: SIDE MIC, FRONT MIC, REAR MIC, SPEAKERS
 - 2 DO NOT OBSTRUCT OPTICAL OPENINGS: FRONT FLASH, REAR IR CAMERA
 - 3 DO NOT OBSTRUCT AMBIENT LIGHT SENSOR
 - 4 DO NOT OBSTRUCT IR CAMERA, FLOOR ILLUMINATOR, FRONT CAMERA & DOT PROJECTION
 - 5 DO NOT HAVE METAL CONTACT WITH DEVICE COVER GLASS

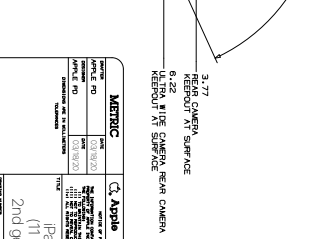
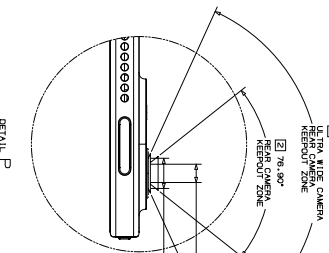
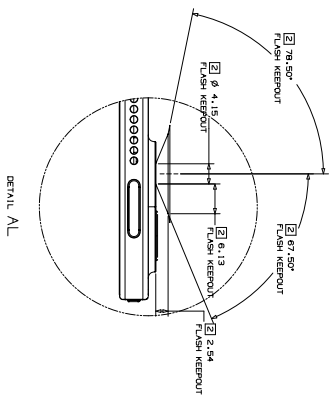
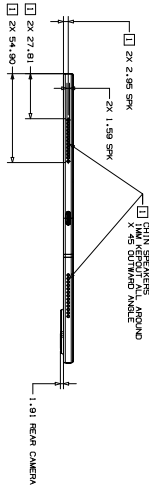
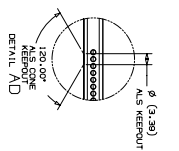
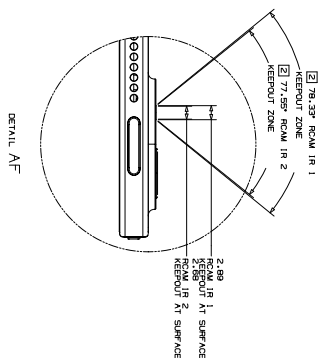
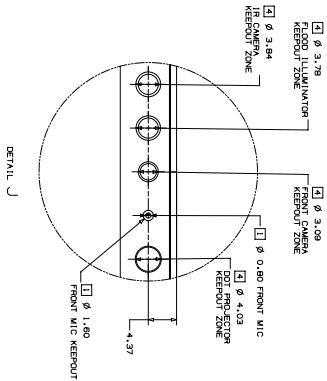
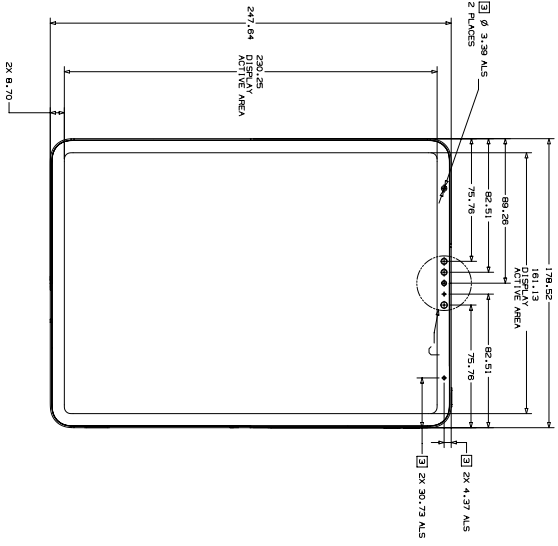
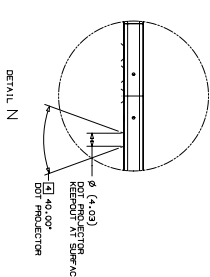
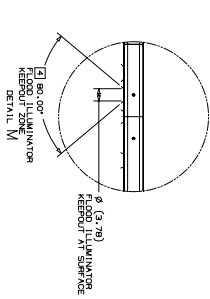
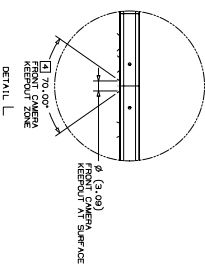
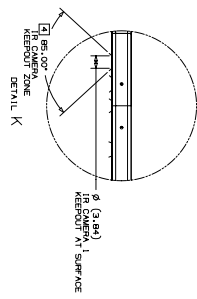
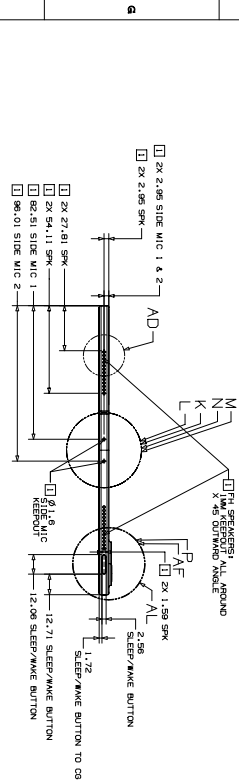

| METRIC | |
|---------------------|-------------|
| UNIT OF MEASUREMENT | MILLIMETERS |
| PRECISION | 0.025 |
| SCALE | 1:1 |
| DATE | 06/05/20 |
| VERSION | 1 |

Apple Inc.
iPad Pro (11-inch) 2nd generation

40.39 iPad Pro (11-inch) 2nd Generation 2 of 5

- 1 DO NOT OBSTRUCT ACOUSTIC OPENINGS, SIDE MIC, FRONT MIC, REAR MIC, SPEAKERS
- 2 DO NOT OBSTRUCT REAR CAMERA, REAR FLASH, & REAR IR CAMERAS
- 3 DO NOT OBSTRUCT IR CAMERA, FLUORO ILLUMINATOR, FRONT CAMERA & DOT PROJECTOR
- 4 DO NOT HAVE METAL CONTACT WITH DEVICE COVER GLASS

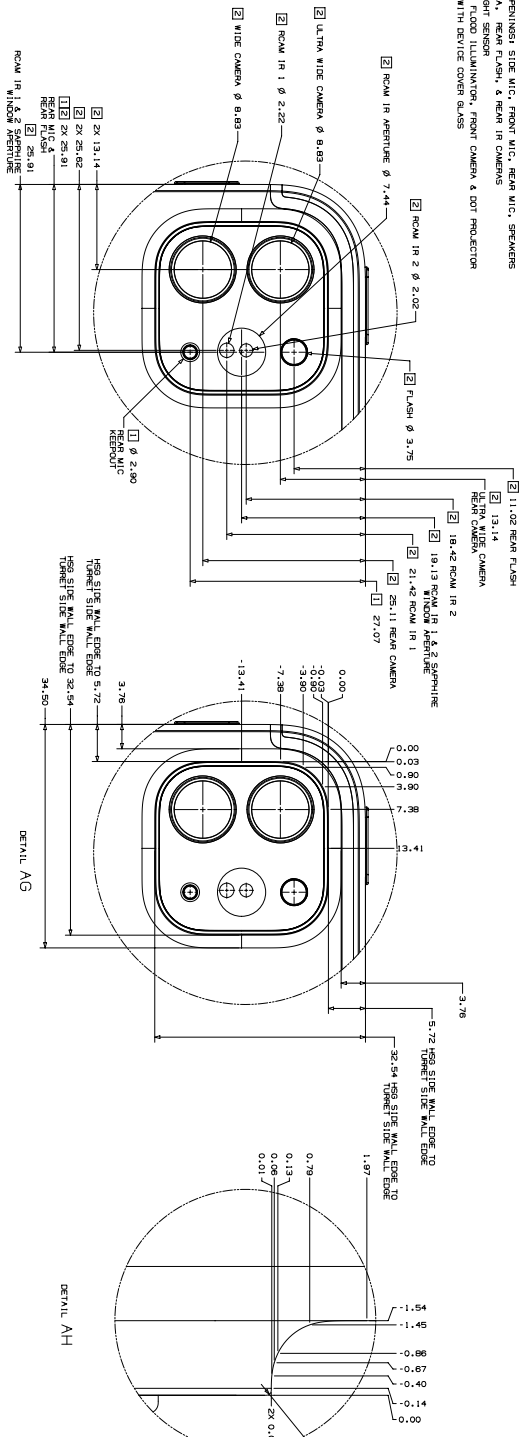

DETAIL T

DETAIL AG

DETAIL AH

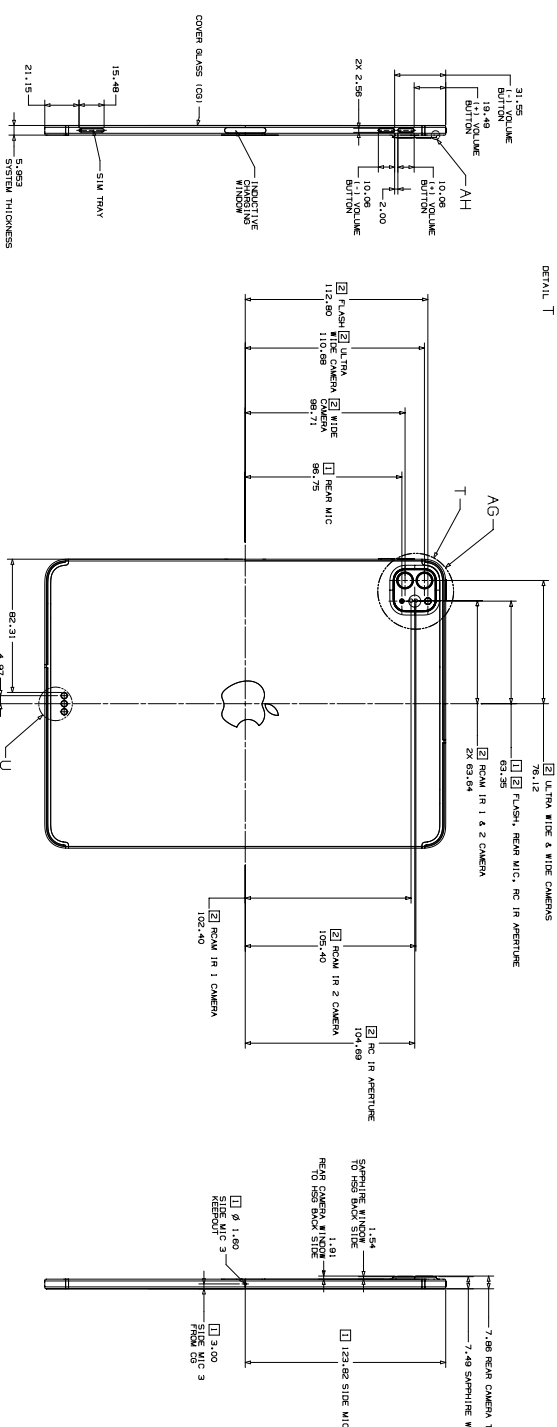

DETAIL U

| | |
|-------------|--------|
| Apple Inc. | |
| Model | 11,2 |
| Part Number | 11,2 |
| Revision | 1 |
| Material | None |
| Quantity | 2 of 5 |

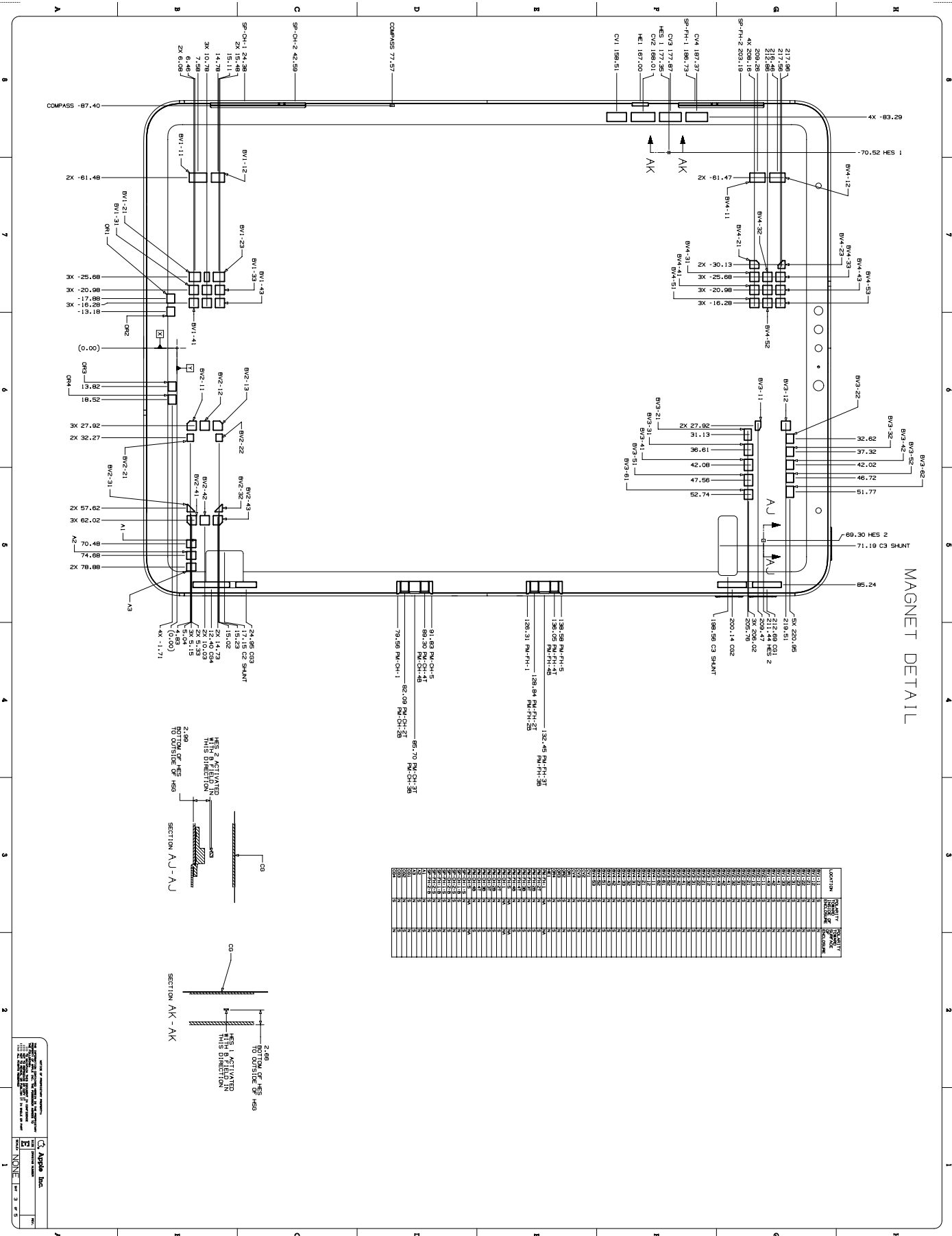

| LOCATION | PROPERTY | SYMBOL |
|----------|----------|--------|
| C1 | UNION | UNION |
| C2 | UNION | UNION |
| C3 | UNION | UNION |
| C4 | UNION | UNION |
| C5 | UNION | UNION |
| C6 | UNION | UNION |
| C7 | UNION | UNION |
| C8 | UNION | UNION |
| C9 | UNION | UNION |
| C10 | UNION | UNION |
| C11 | UNION | UNION |
| C12 | UNION | UNION |
| C13 | UNION | UNION |
| C14 | UNION | UNION |
| C15 | UNION | UNION |
| C16 | UNION | UNION |
| C17 | UNION | UNION |
| C18 | UNION | UNION |
| C19 | UNION | UNION |
| C20 | UNION | UNION |
| C21 | UNION | UNION |
| C22 | UNION | UNION |
| C23 | UNION | UNION |
| C24 | UNION | UNION |
| C25 | UNION | UNION |
| C26 | UNION | UNION |
| C27 | UNION | UNION |
| C28 | UNION | UNION |
| C29 | UNION | UNION |
| C30 | UNION | UNION |
| C31 | UNION | UNION |
| C32 | UNION | UNION |
| C33 | UNION | UNION |
| C34 | UNION | UNION |
| C35 | UNION | UNION |
| C36 | UNION | UNION |
| C37 | UNION | UNION |
| C38 | UNION | UNION |
| C39 | UNION | UNION |
| C40 | UNION | UNION |
| C41 | UNION | UNION |
| C42 | UNION | UNION |
| C43 | UNION | UNION |
| C44 | UNION | UNION |
| C45 | UNION | UNION |
| C46 | UNION | UNION |
| C47 | UNION | UNION |
| C48 | UNION | UNION |
| C49 | UNION | UNION |
| C50 | UNION | UNION |
| C51 | UNION | UNION |
| C52 | UNION | UNION |
| C53 | UNION | UNION |
| C54 | UNION | UNION |
| C55 | UNION | UNION |
| C56 | UNION | UNION |
| C57 | UNION | UNION |
| C58 | UNION | UNION |
| C59 | UNION | UNION |
| C60 | UNION | UNION |
| C61 | UNION | UNION |
| C62 | UNION | UNION |
| C63 | UNION | UNION |
| C64 | UNION | UNION |
| C65 | UNION | UNION |
| C66 | UNION | UNION |
| C67 | UNION | UNION |
| C68 | UNION | UNION |
| C69 | UNION | UNION |
| C70 | UNION | UNION |
| C71 | UNION | UNION |
| C72 | UNION | UNION |
| C73 | UNION | UNION |
| C74 | UNION | UNION |
| C75 | UNION | UNION |
| C76 | UNION | UNION |
| C77 | UNION | UNION |
| C78 | UNION | UNION |
| C79 | UNION | UNION |
| C80 | UNION | UNION |

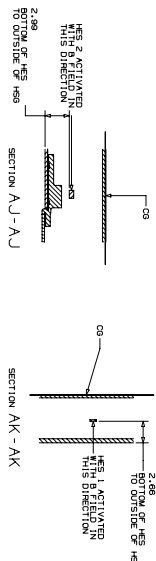

40.42 iPad Pro (11-inch) 2nd Generation 5 of 5

ANTENNA KEEPOUT

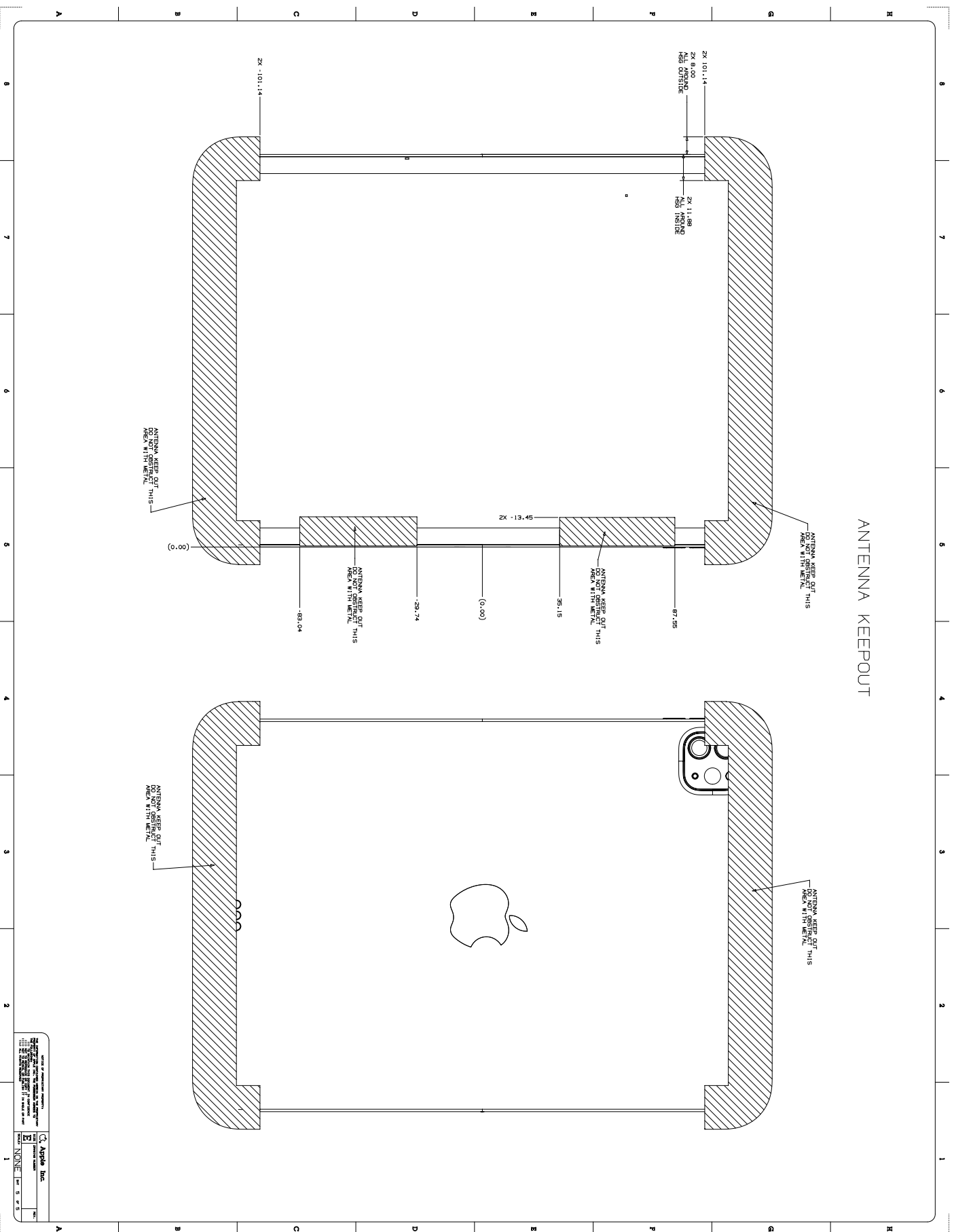

11
 12
 13
 14
 15
 16
 17
 18
 19
 20
 21
 22
 23
 24
 25
 26
 27
 28
 29
 30
 31
 32
 33
 34
 35
 36
 37
 38
 39
 40
 41
 42
 43
 44
 45
 46
 47
 48
 49
 50
 51
 52
 53
 54
 55
 56
 57
 58
 59
 60
 61
 62
 63
 64
 65
 66
 67
 68
 69
 70
 71
 72
 73
 74
 75
 76
 77
 78
 79
 80
 81
 82
 83
 84
 85
 86
 87
 88
 89
 90
 91
 92
 93
 94
 95
 96
 97
 98
 99
 100

40.43 iPad (7th generation) & iPad (8th generation) 1 of 3

NOTES (UNLESS OTHERWISE SPECIFIED)

- 1 DO NOT OBSTRUCT ACOUSTIC OPENINGS: SIDE MIC, REAR MIC, AUDIO JACK, SPEAKERS
- 2 DO NOT OBSTRUCT IMAGING FEATURES: FRONT CAMERA, REAR CAMERA
- 3 DO NOT OBSTRUCT AMBIENT LIGHT SENSOR (ALS)
- 4 DO NOT OBSTRUCT THE HOME BUTTON
- 5 DO NOT OBSTRUCT GLASS WITH METAL
- 6 DO NOT OBSTRUCT ENCLOSURE WITH METAL
- 7 CELLULAR SYSTEM ONLY

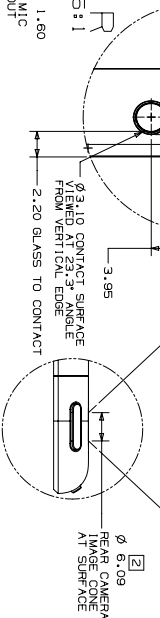
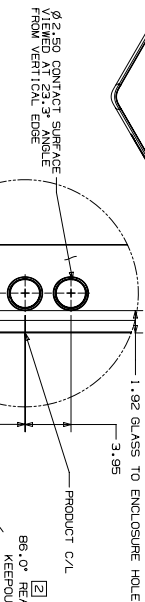
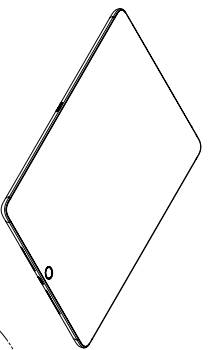
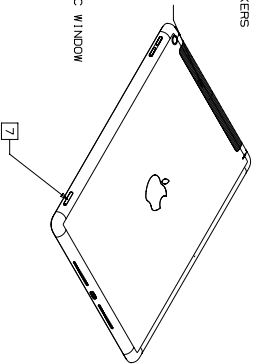

DETAIL B
SCALE 2:1

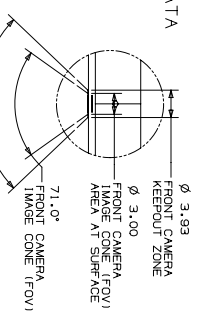
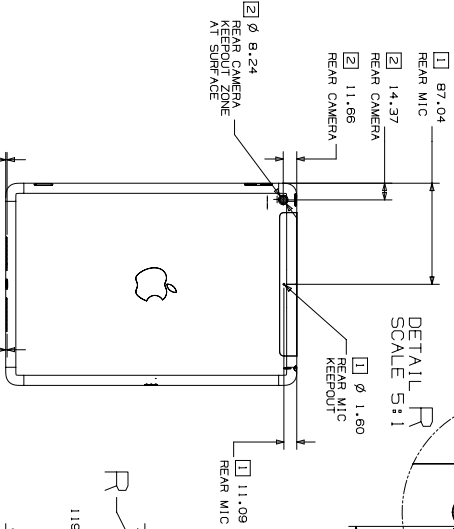

DETAIL C
SCALE 3:1

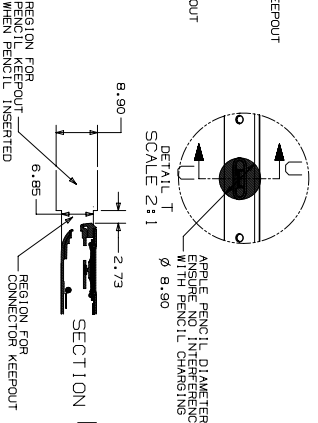
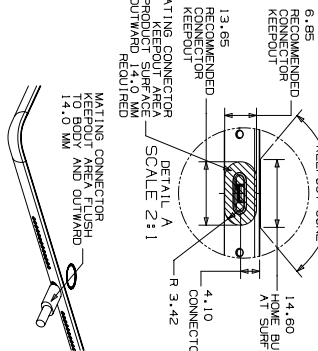
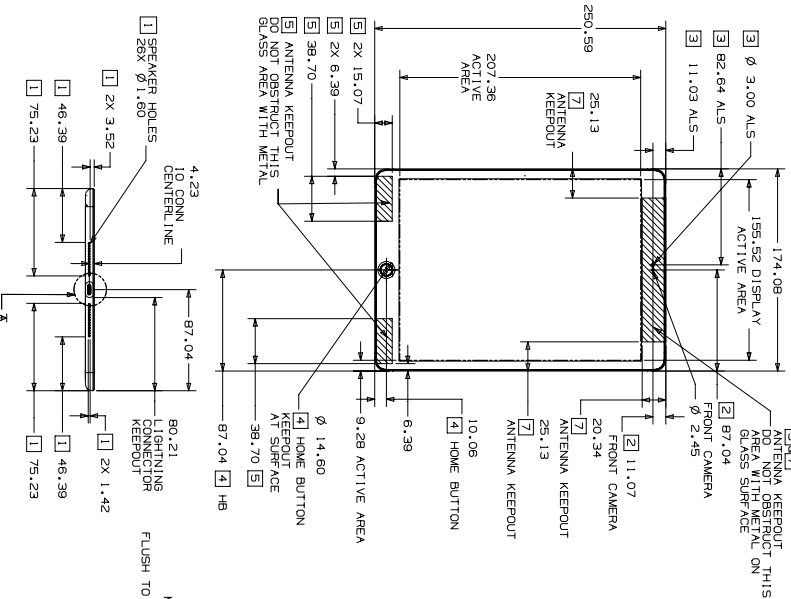

| MFR/RC | DATE | DESCRIPTION |
|--|-------------|--|
| APPLE INC. | 09/15/00 | VOICE OF THE CUSTOMER |
| APPLE INC. | 09/15/00 | THE INFORMATION ON THIS DRAWING IS THE PROPERTY OF APPLE INC. IT IS TO BE USED FOR THE DESIGN AND MANUFACTURE OF THE PRODUCT DESCRIBED HEREIN. IT IS TO BE KEPT IN CONFIDENTIALITY AND IS NOT TO BE REPRODUCED OR TRANSMITTED IN ANY FORM OR BY ANY MEANS, ELECTRONIC OR MECHANICAL, INCLUDING PHOTOCOPYING, RECORDING, OR BY ANY INFORMATION STORAGE AND RETRIEVAL SYSTEM, WITHOUT THE EXPRESS WRITTEN PERMISSION OF APPLE INC. |
| APPLE INC. | 09/15/00 | CHANGING THE DIMENSIONS |
| DATE | DESCRIPTION | BY |
| X.X | 10.2 | |
| X.XX | 10.10 | |
| X.XXX | 10.080 | |
| DO NOT SCALE DIMENSIONS | | |
| ANGLES 10-5° | | |
| DRAWING NUMBER | | |
| TITLE | | |
| iPad (7th generation), iPad (8th generation) | | |
| DRAWING NUMBER | | |
| SCALE | | |
| NONE | | |
| SHEET 1 OF 3 | | |

MX GENERATED

40.44 iPad (7th generation) & iPad (8th generation) 2 of 3

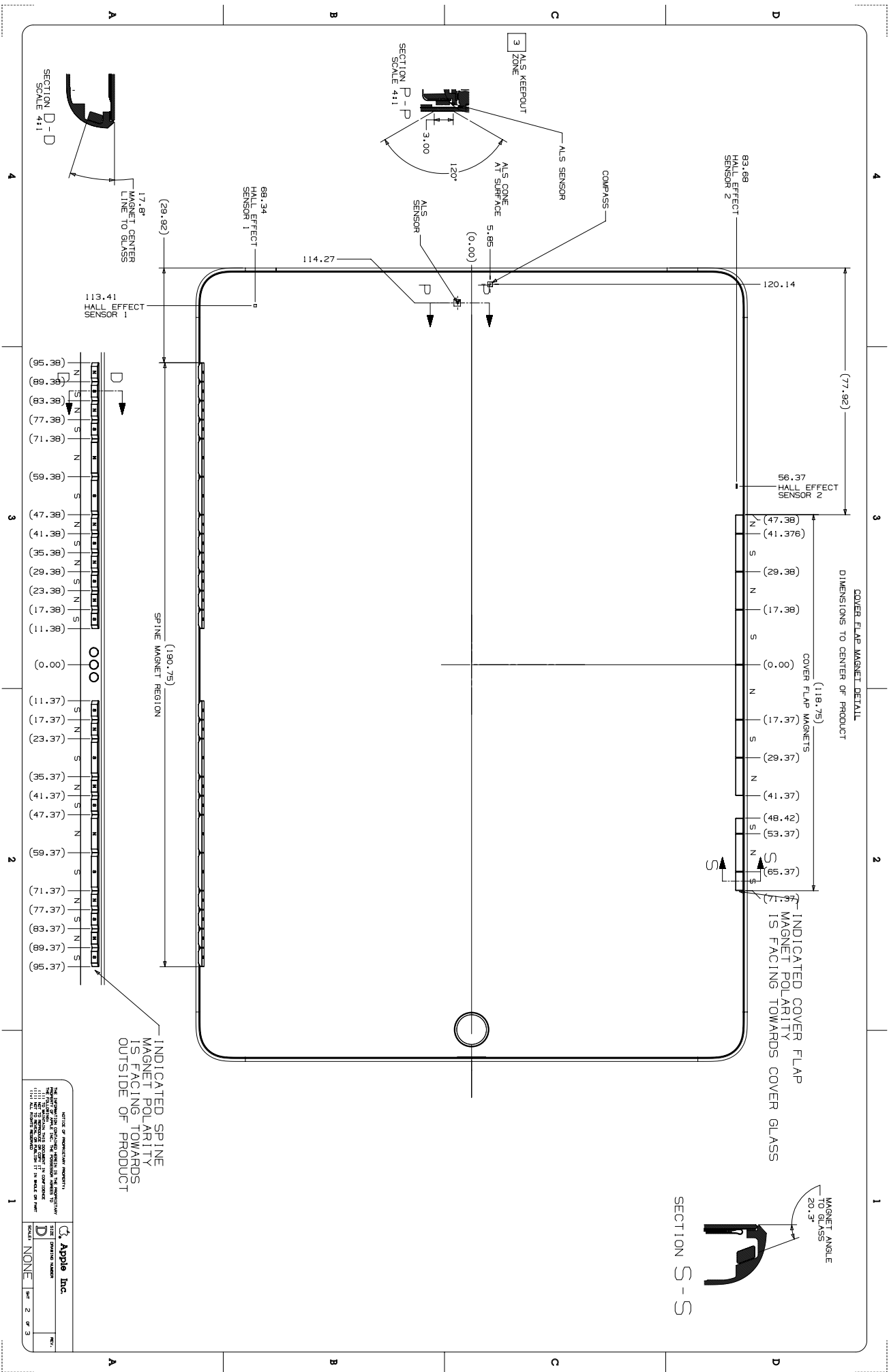

Apple Inc.
Apple logo
Apple Inc.
© Apple Inc. 2020

40.45 iPad (7th generation) & iPad (8th generation) 3 of 3

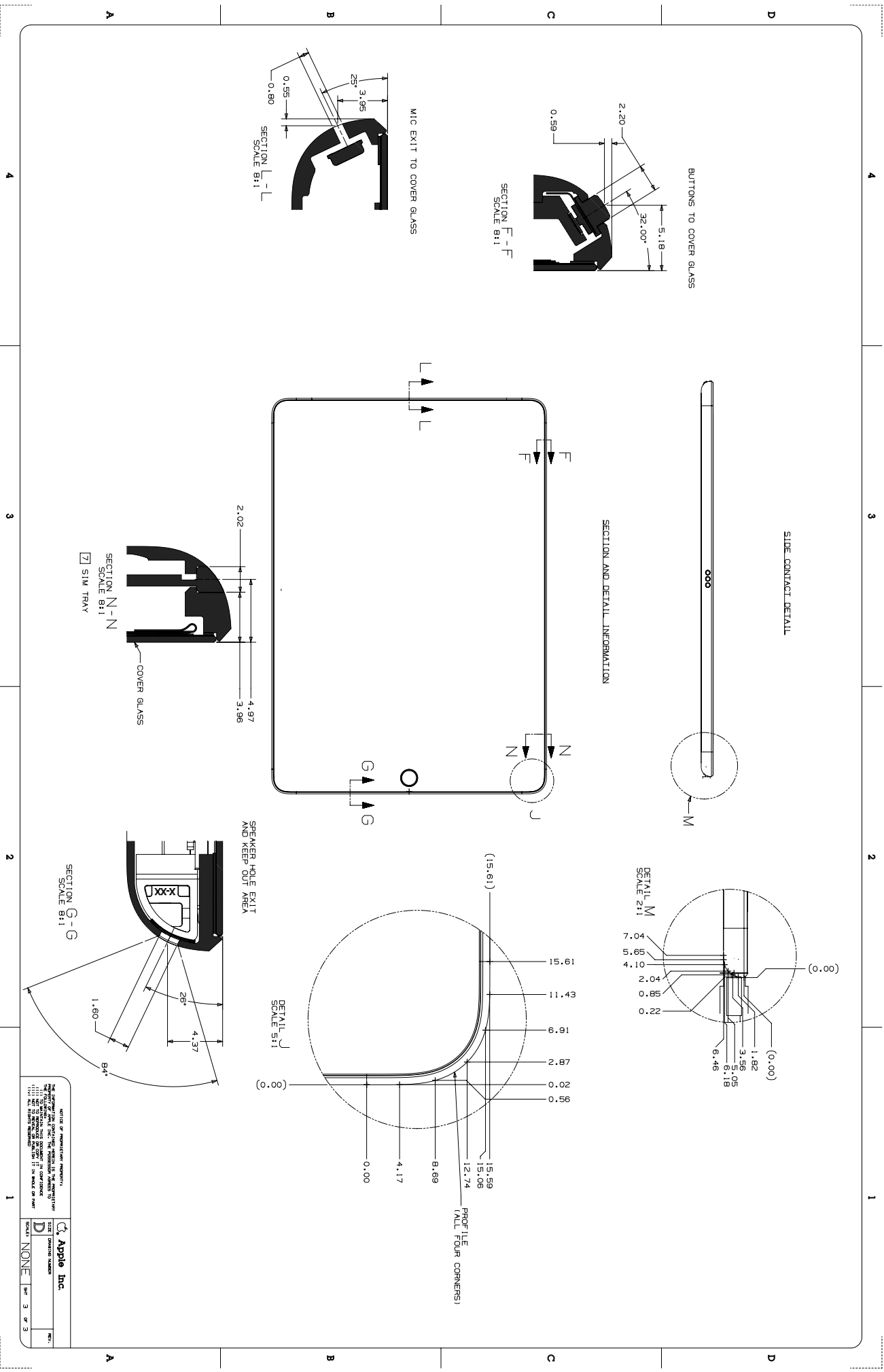

Apple Inc. is not responsible for damage to the device or data loss due to unauthorized use of the device. Apple Inc. is not responsible for damage to the device or data loss due to unauthorized use of the device. Apple Inc. is not responsible for damage to the device or data loss due to unauthorized use of the device.

Apple Inc.
Apple Logo
D NONE 3 of 3

40.46 iPad Air (3rd generation) with Wi-Fi 1 of 3

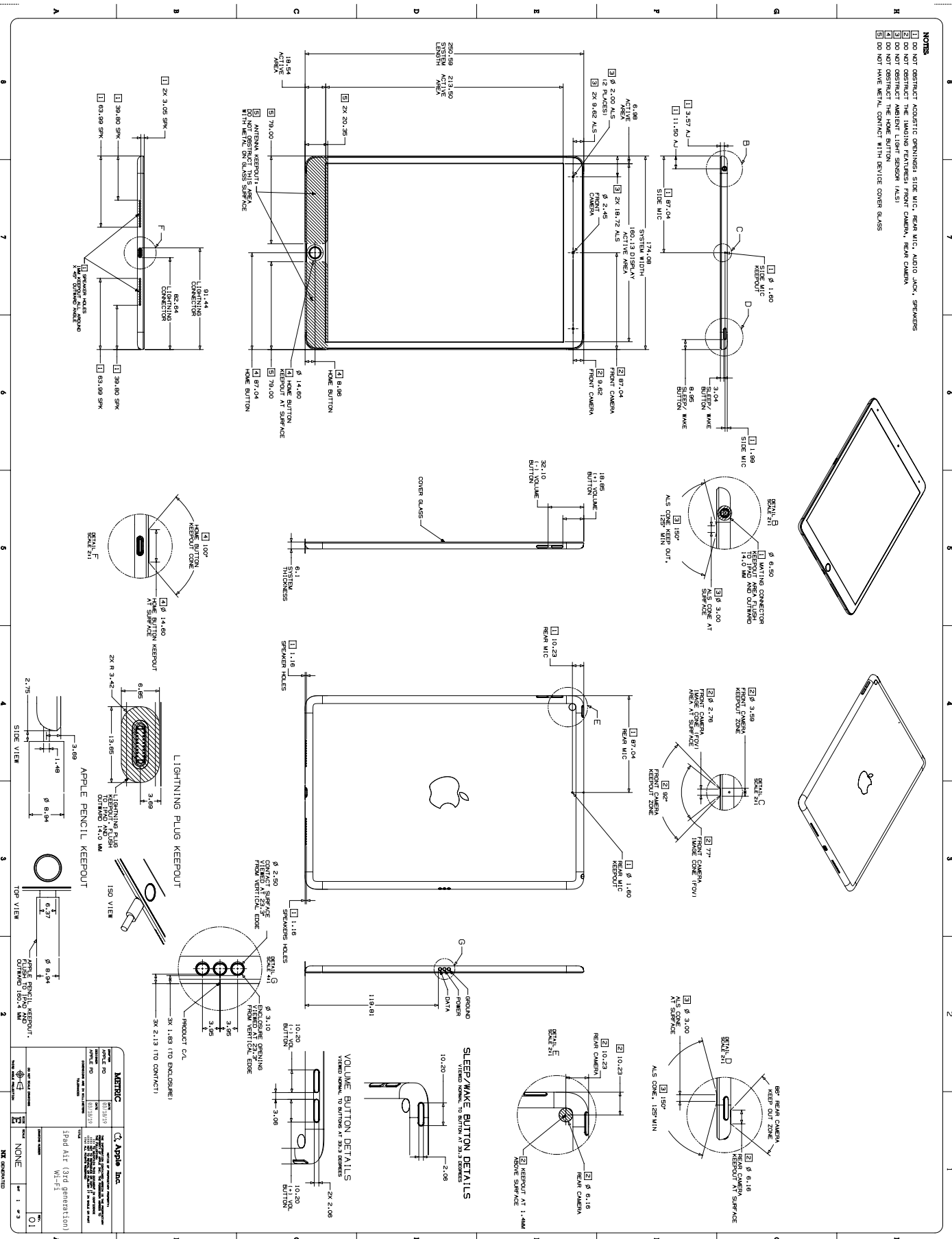

40.47 iPad Air (3rd generation) with Wi-Fi 2 of 3

COVER FLAP MAGNET DETAIL
 POLARITY SHOWN NORMAL TO GLASS
 DIMENSIONS TO CENTER OF PRODUCT
 N = NORTH
 S = SOUTH

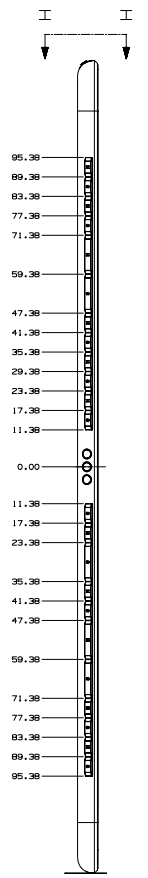
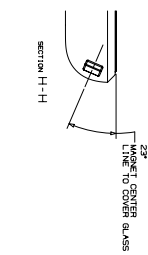
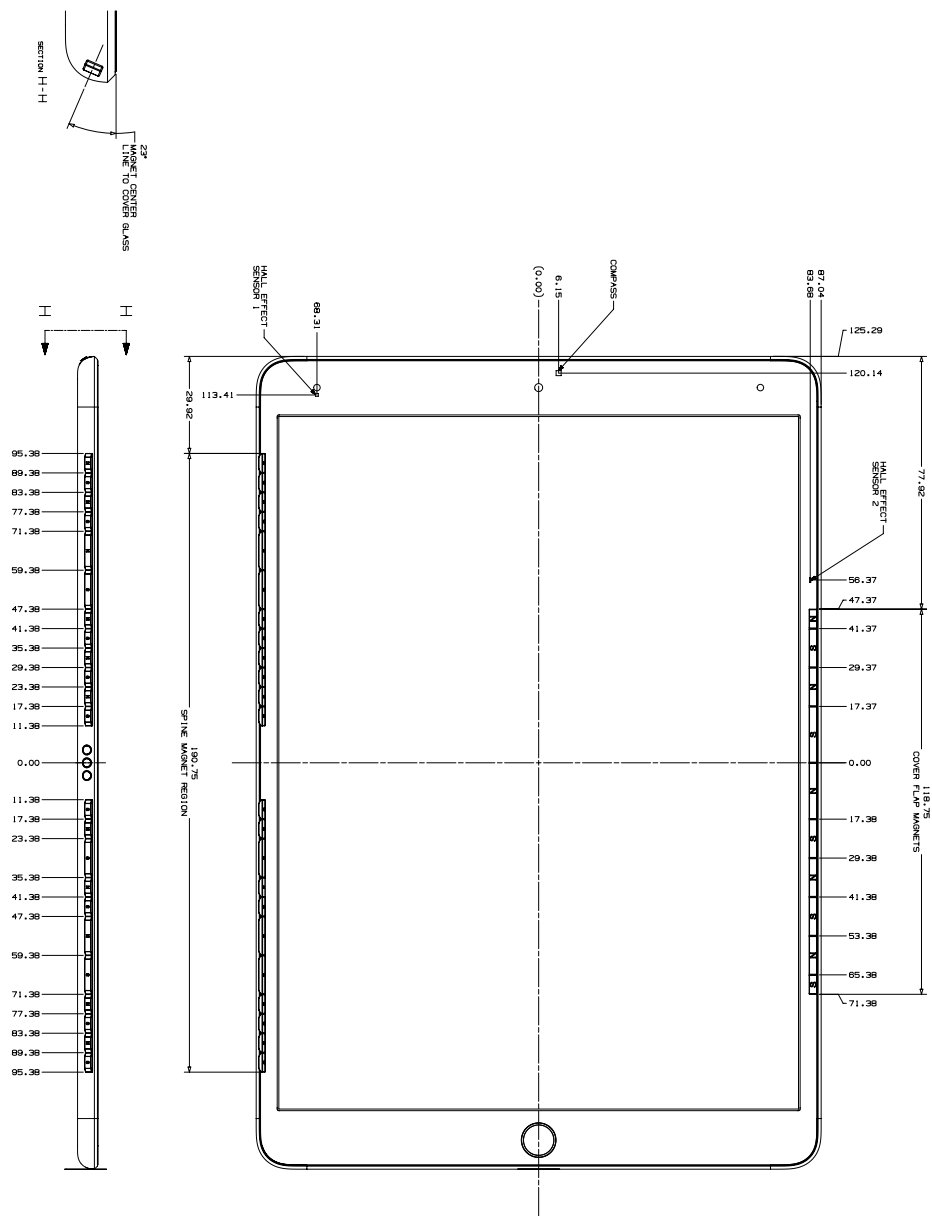

| | |
|----------------|-----------------|
| Apple Inc. | Apple logo |
| Model: A1892 | Part Number: 01 |
| Revision: 1 | Quantity: 1 |
| Material: None | Color: None |
| Notes: | |

40.48 iPad Air (3rd generation) with Wi-Fi 3 of 3

SECTION AND DETAIL INFORMATION

VOLUME BUTTONS

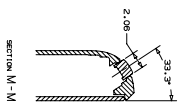

CORNER SPLINE - TOP VIEW

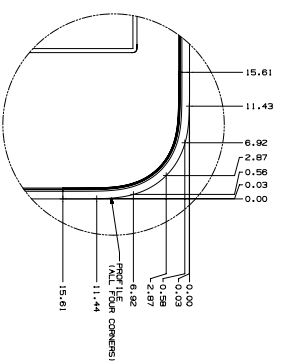

SLEEP / WAKE BUTTON

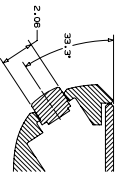

SECTION N-N

SPLINE MIC

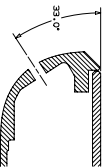

SECTION K-K

SPEAKER HOLES AND KEEP OUT AREA

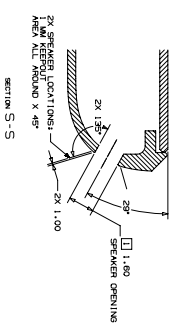

SPLINE - SIDE VIEW

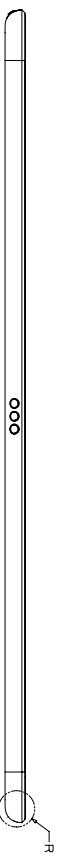
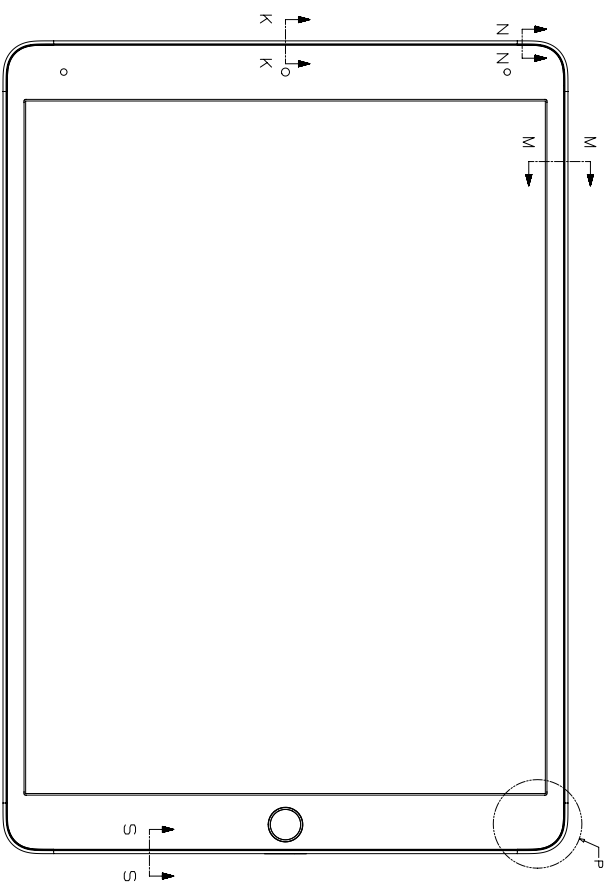
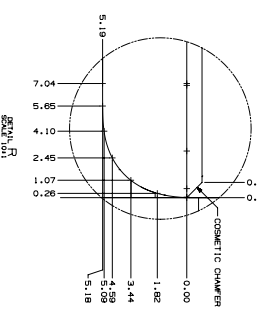

| | | | |
|--|-----|-------|--|
| SECTION OF MODIFICATION INFORMATION REVISIONS 01 NONE | | | |
| DATE | BY | APP'D | |
| 10/16/20 | ADP | ADP | |

40.49 iPad Air (3rd generation) with Wi-Fi + Cellular 1 of 3

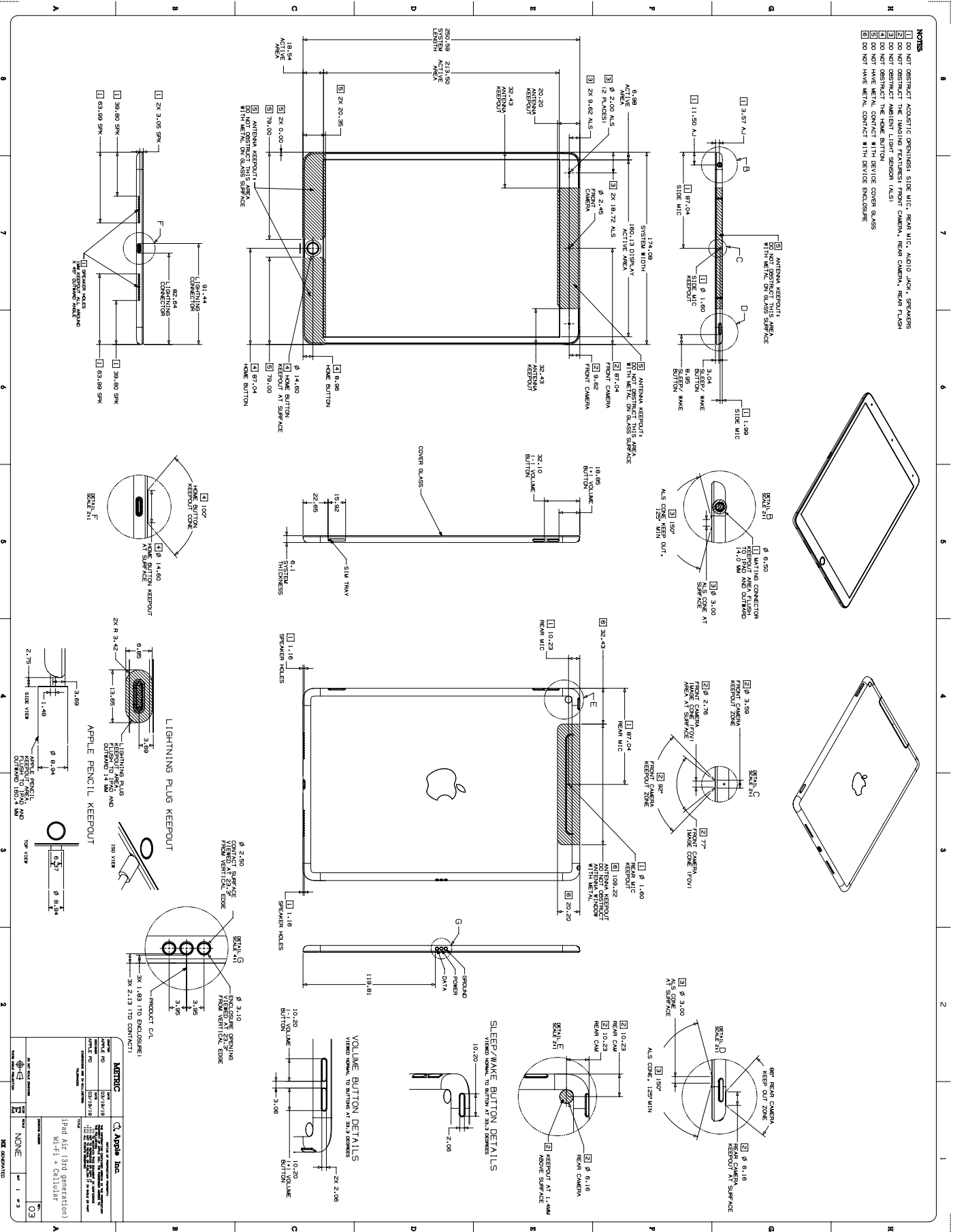

40.50 iPad Air (3rd generation) with Wi-Fi + Cellular 2 of 3

COVER FLAP MAGNET DETAIL
 POLARITY SHOWN NORMAL TO GLASS
 DIMENSIONS TO CENTER OF PRODUCT
 N = NORTH
 S = SOUTH

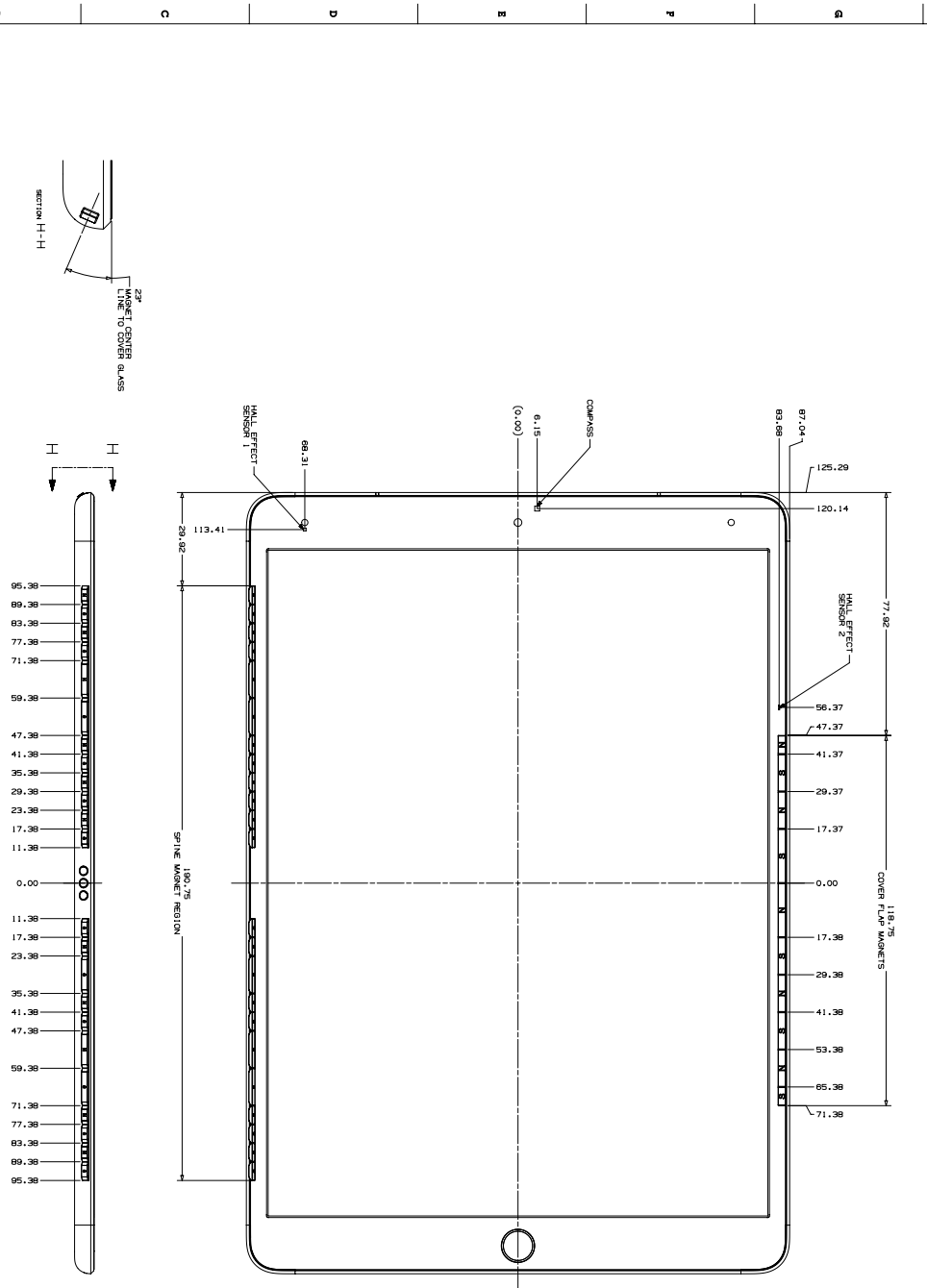

| | |
|-----------------|------|
| Apple Inc. logo | |
| Part Number | 103 |
| Revision | 1 |
| Quantity | 1 |
| Unit of Measure | None |

40.51 iPad Air (3rd generation) with Wi-Fi + Cellular 3 of 3

SECTION AND DETAIL INFORMATION

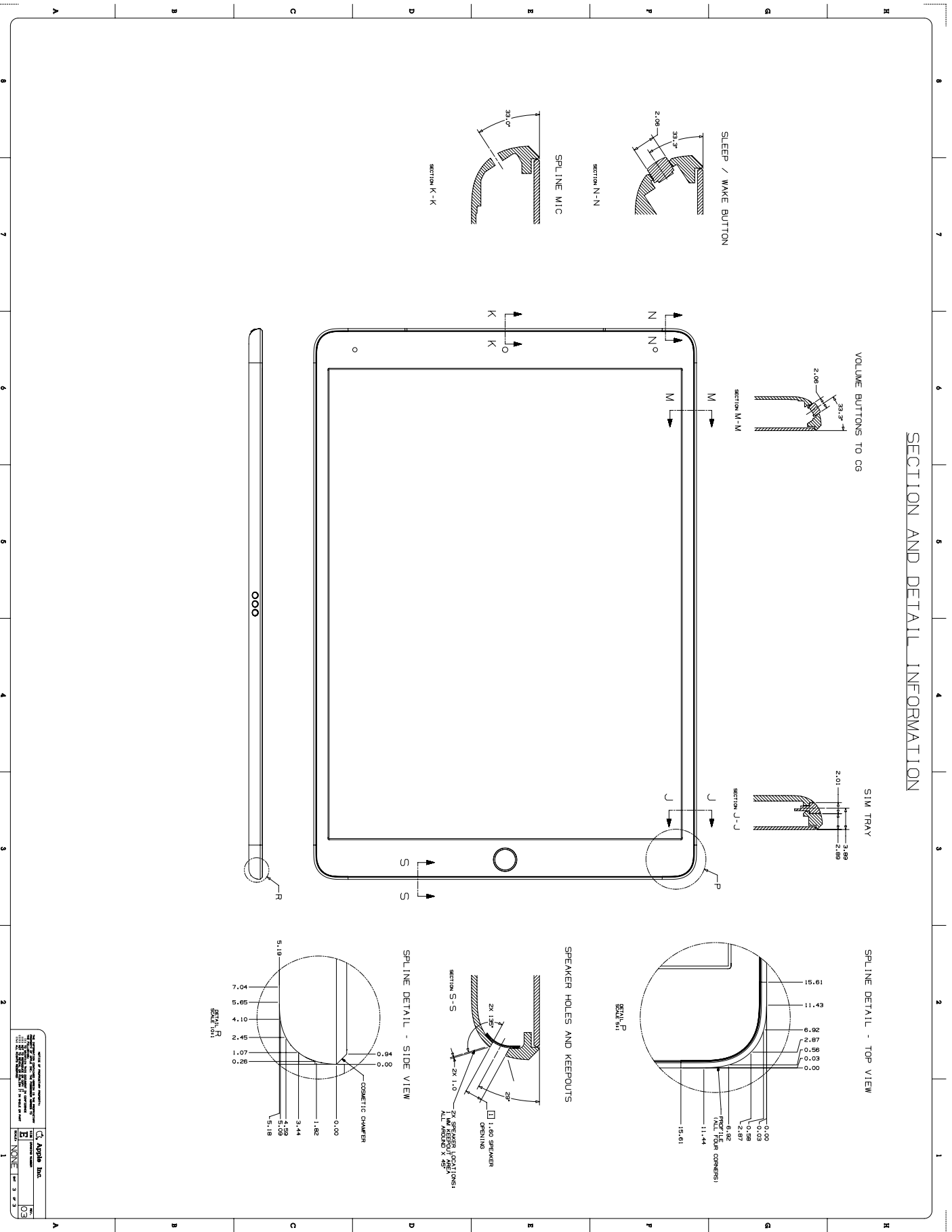

VOLUME BUTTONS TO CG

SIM TRAY

SPLINE DETAIL - TOP VIEW

SPEAKER HOLES AND KEEPOUTS

SPLINE DETAIL - SIDE VIEW

| | |
|------------|------|
| Apple Inc. | |
| Model | 03 |
| Revision | 1 |
| Material | NONE |
| Color | 3 |
| Finish | 3 |
| Notes | |

40.52 iPad mini (5th generation) with Wi-Fi 1 of 3

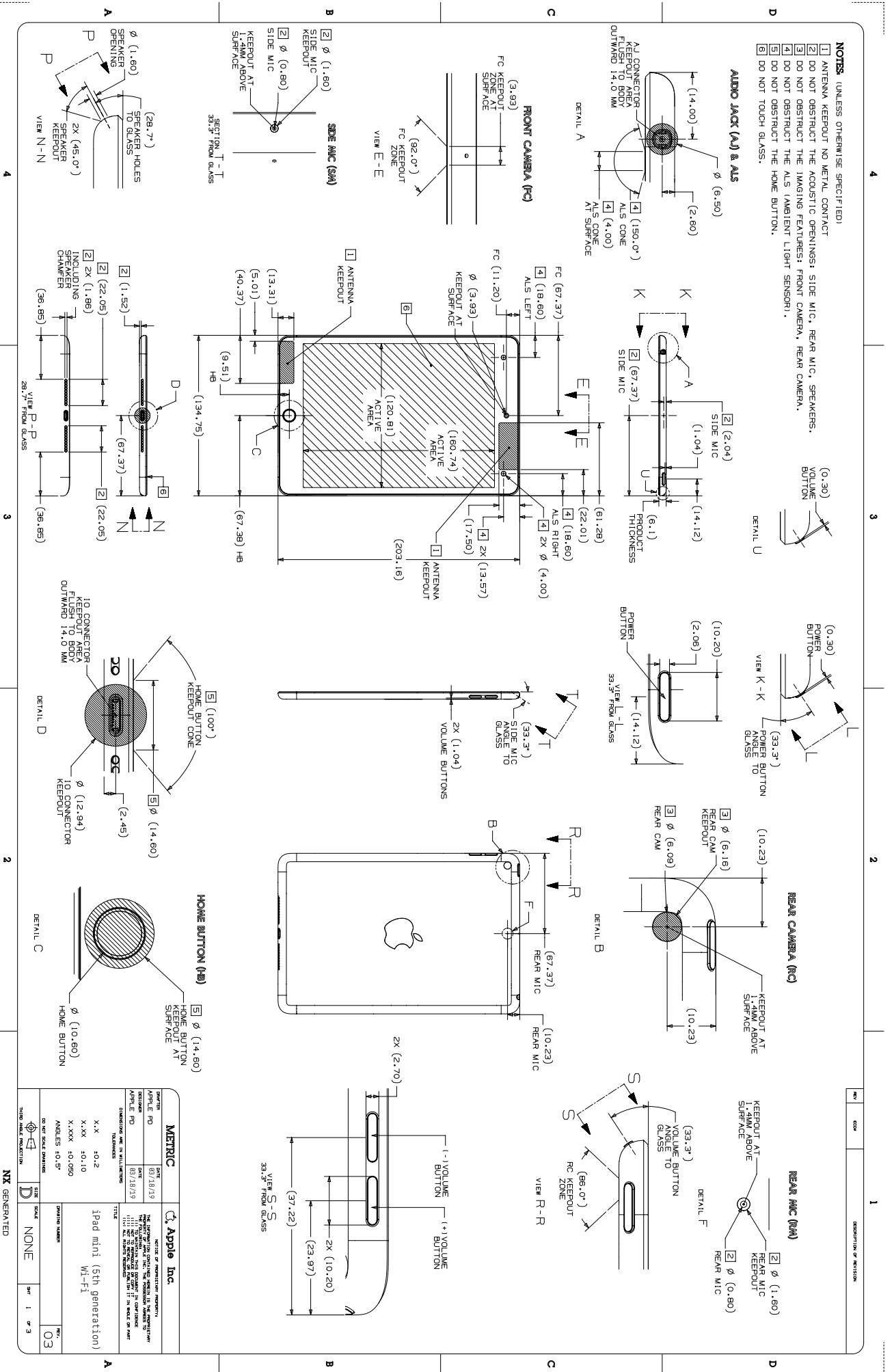

| MTRIC | | | Apple Inc. |
|--|--------|-------|------------|
| DATE | 8/7/13 | REV | |
| APPROVED BY | | DATE | |
| DESIGNED BY | | DATE | |
| <small>THIS DRAWING IS THE PROPERTY OF APPLE INC. IT IS TO BE USED ONLY FOR THE PURPOSES SPECIFIED HEREIN. IT IS NOT TO BE REPRODUCED OR TRANSMITTED IN ANY FORM OR BY ANY MEANS, ELECTRONIC OR MECHANICAL, INCLUDING PHOTOCOPYING, RECORDING, OR BY ANY INFORMATION STORAGE AND RETRIEVAL SYSTEM, WITHOUT PERMISSION IN WRITING FROM APPLE INC.</small> | | | |
| <small>DATE: 8/7/13 11:45 AM FILE: 40.52 iPad mini (5th generation) with Wi-Fi 1 of 3.dwg TITLE: iPad mini (5th generation) with Wi-Fi</small> | | | |
| <small>DO NOT SCALE DIMENSIONS</small> | | | |
| SCALE | NONE | SHEET | 1 of 3 |
| DESIGNED BY | | DATE | |
| DATE | | REV | |

40.53 iPad mini (5th generation) with Wi-Fi 2 of 3

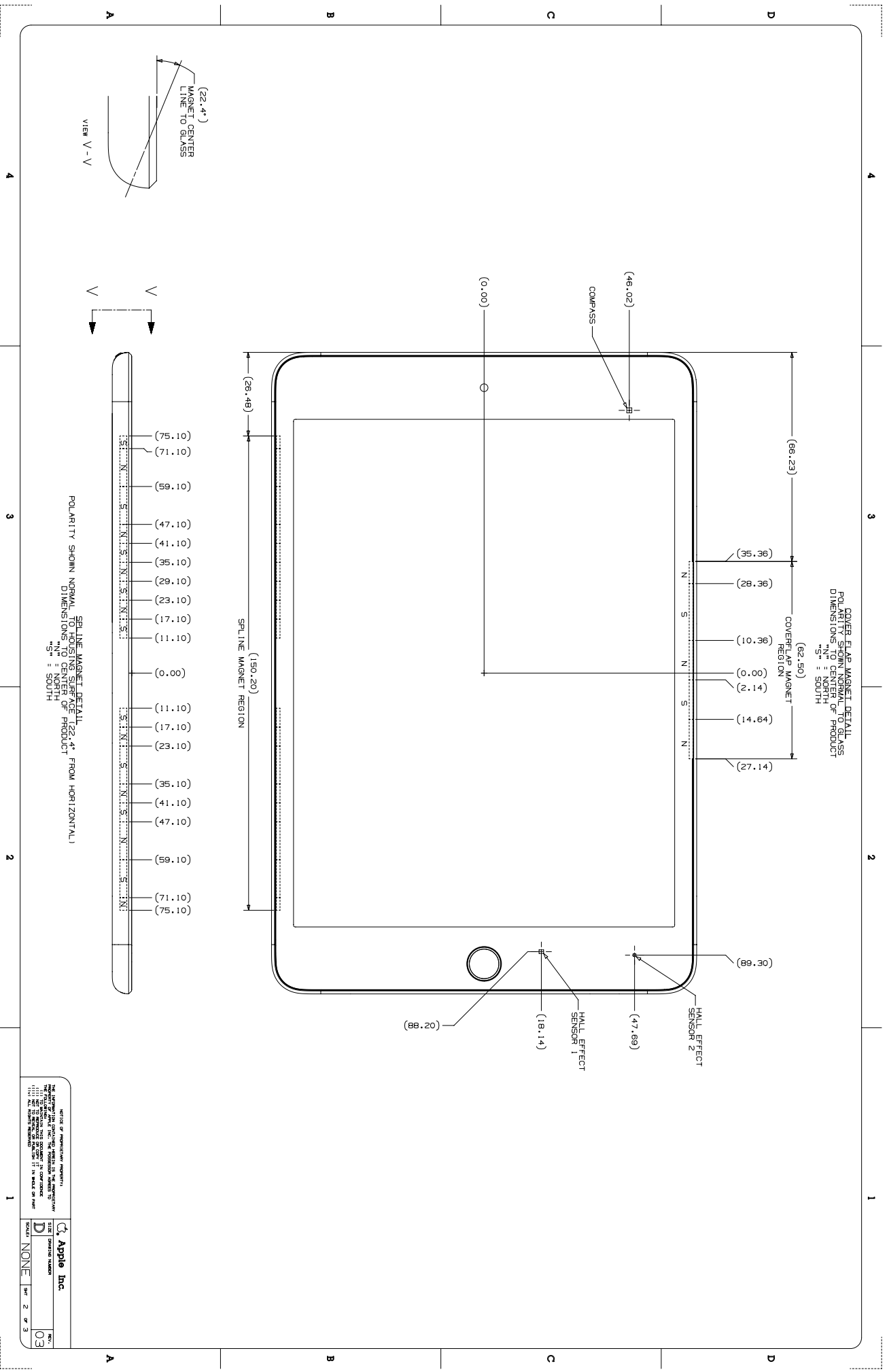

40.54 iPad mini (5th generation) with Wi-Fi 3 of 3

APPLE PENCIL AND PROFILE DETAIL

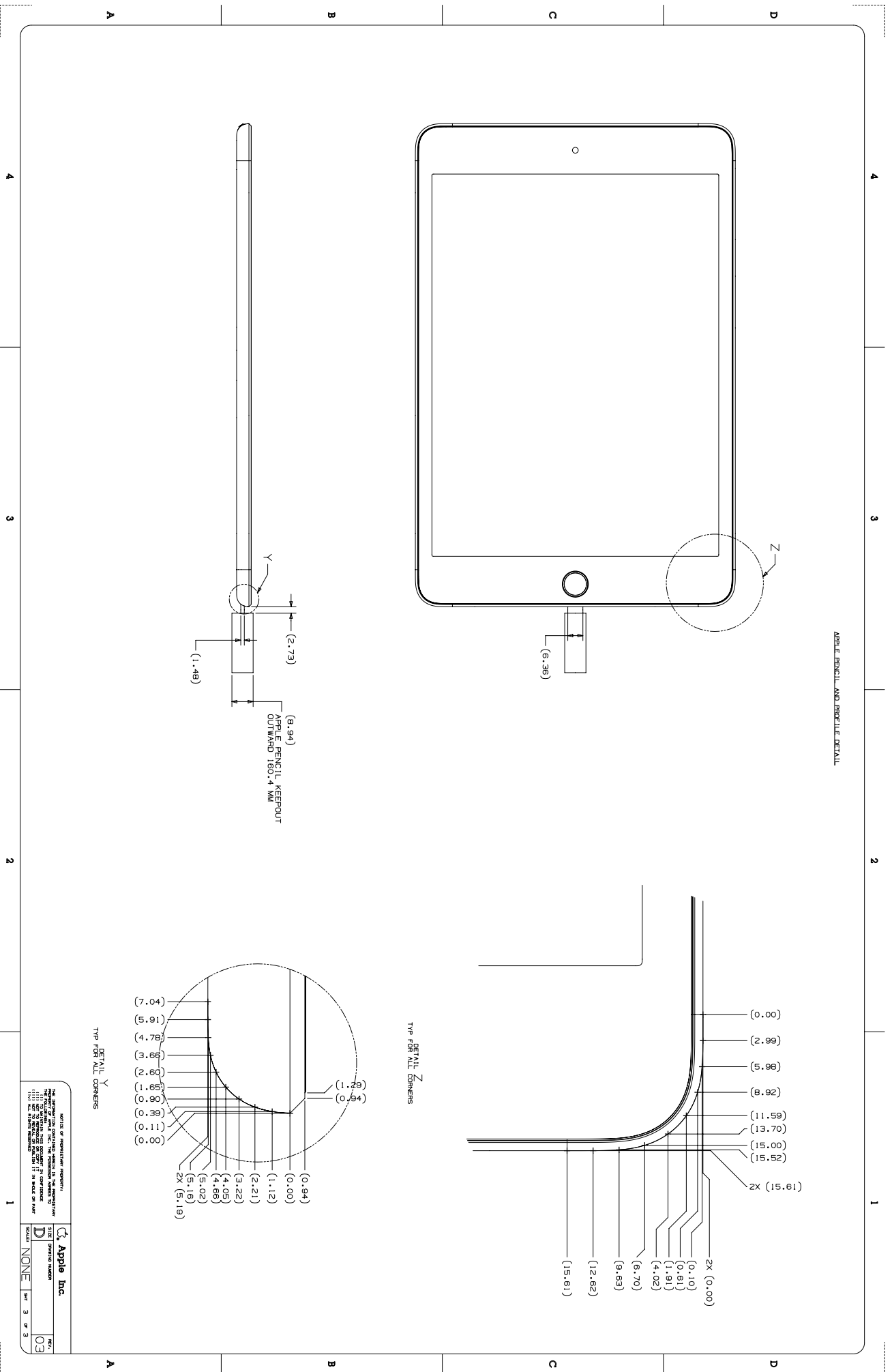

NOTES (UNLESS OTHERWISE SPECIFIED):

- 1 ANTENNA KEEP-OUT NO METAL CONTACT
- 2 DO NOT OBSTRUCT THE ACOUSTIC OPENINGS: SIDE MIC, REAR MIC, SPEAKERS.
- 3 DO NOT OBSTRUCT THE IMAGING FEATURES: FRONT CAMERA, REAR CAMERA.
- 4 DO NOT OBSTRUCT THE ALS (AMBIENT LIGHT SENSOR).
- 5 DO NOT OBSTRUCT THE HOME BUTTON.
- 6 DO NOT TOUCH GLASS.

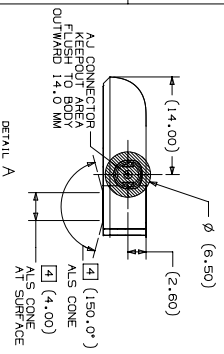
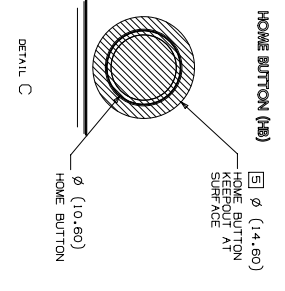
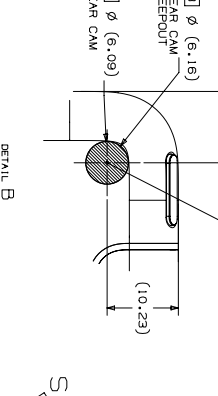
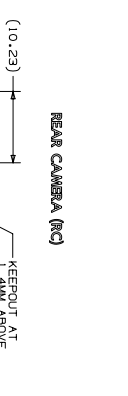
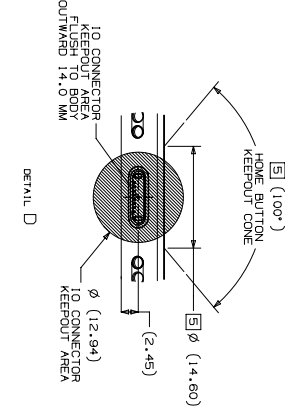
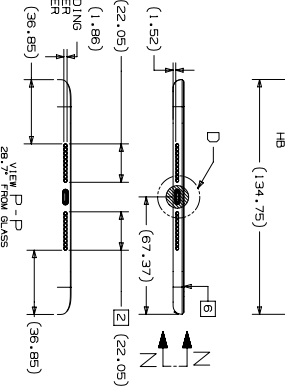
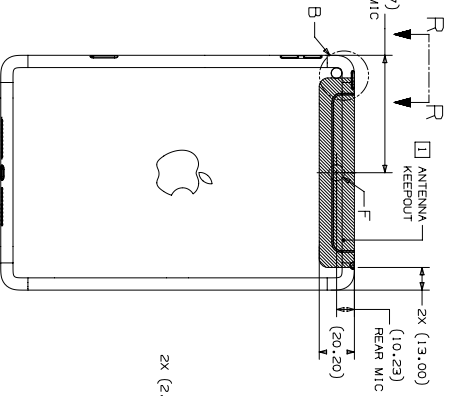
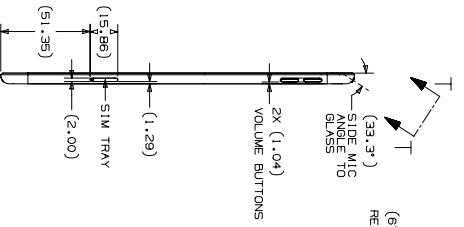
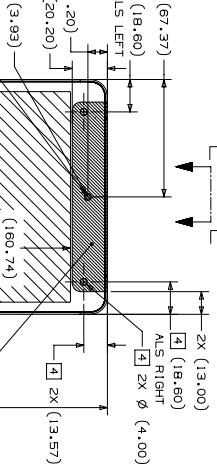
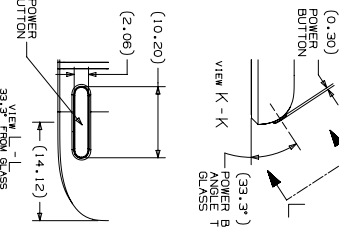
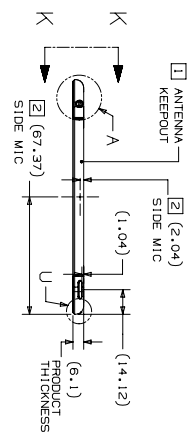
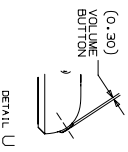
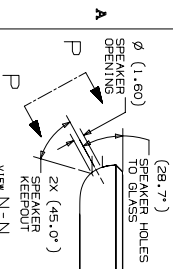
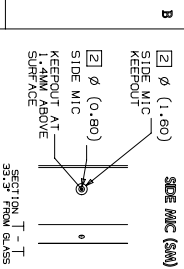
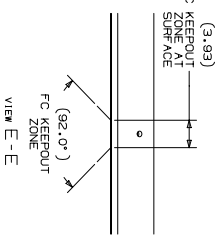
AUDIO JACK (A) & ALS

FRONT CAMERA (FC)

| METRIC | DATE | DESCRIPTION OF REVISION |
|-------------------------|---|---|
| APPL E PD | 83/18/19 | VOICE OF PATENT RIGHTS |
| APPL E PD | 83/18/19 | THE PATENT RIGHTS IN THE PRODUCT ARE THE PROPERTY OF APPLE INC. AND ARE NOT TO BE REPRODUCED OR TRANSMITTED IN ANY FORM OR BY ANY MEANS, ELECTRONIC OR MECHANICAL, INCLUDING PHOTOCOPYING, RECORDING, OR BY ANY INFORMATION STORAGE AND RETRIEVAL SYSTEM. |
| DESIGNER | 93/18/19 | 93/18/19 |
| DATE | | |
| DRAWN BY | | |
| CHECKED BY | | |
| TITLE | iPad mini (5th generation) Wi-Fi + Cellular | |
| OR NOT SCALE DIMENSIONS | | |
| DO NOT SCALE DIMENSIONS | | |
| ANGLES | 10.5° | |
| DATE | 03 | |
| REV | 1 | 3 |

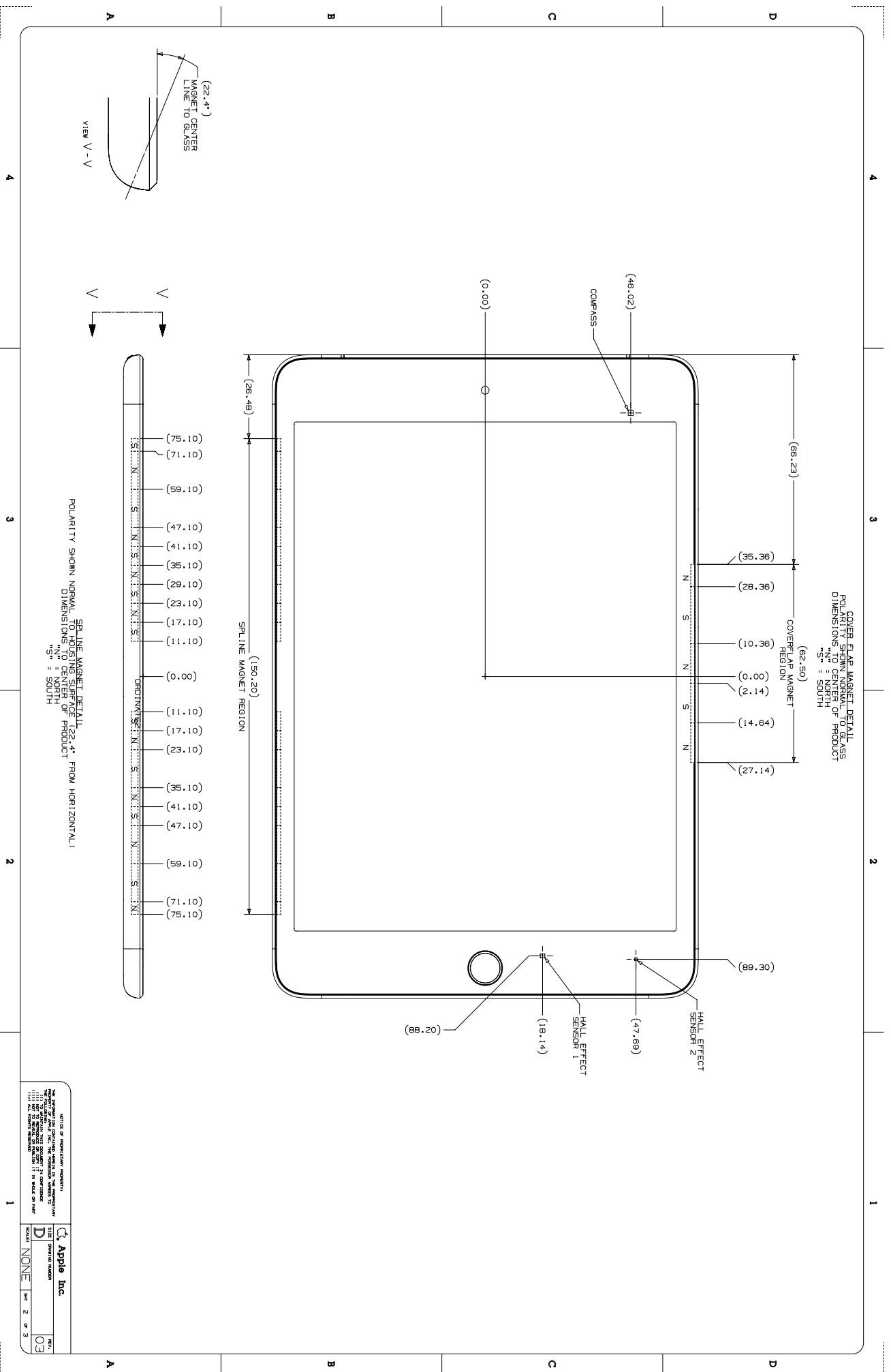
40.56 iPad mini (5th generation) with Wi-Fi + Cellular 2 of 3



40.57 iPad mini (5th generation) with Wi-Fi + Cellular 3 of 3

APPLE PENCIL AND PROFILE DETAIL

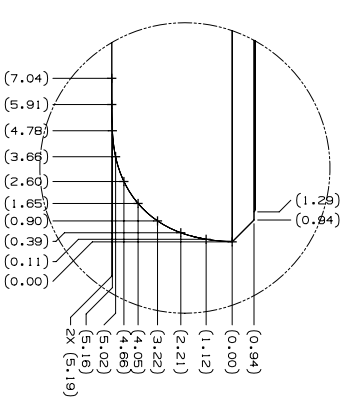
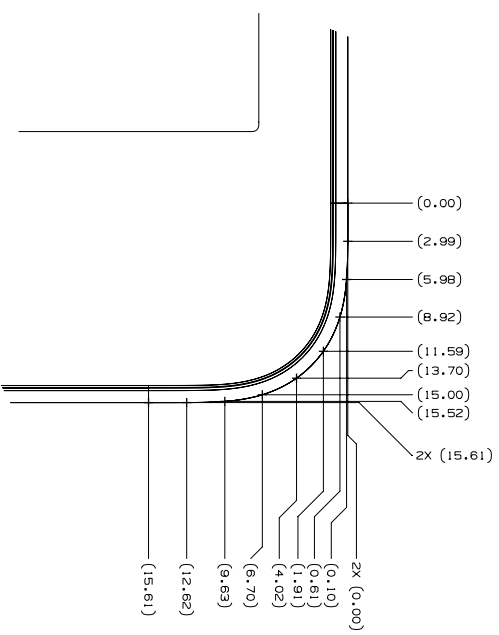
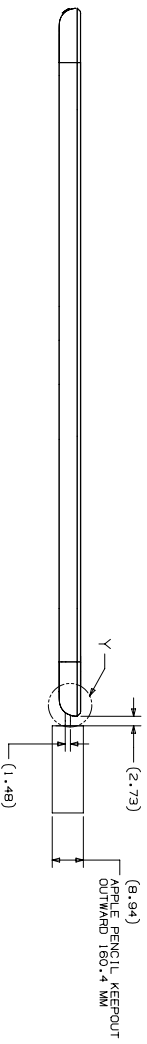
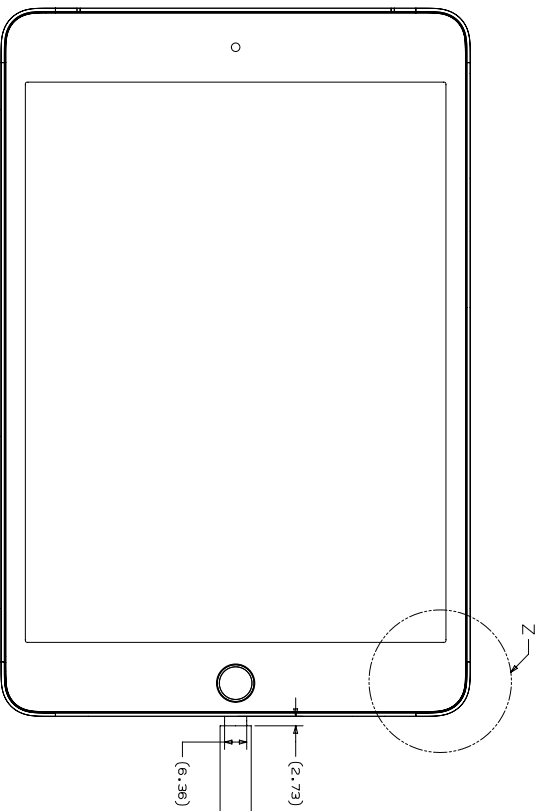

Apple Inc. logo and text: APPLE INC., 100 Apple Park Blvd, Cupertino, CA 95014. Includes a table with columns for 'PART NUMBER', 'REV', and 'DATE'.

| PART NUMBER | REV | DATE |
|-------------|-----|------|
| D | 03 | |

40.58 iPad Pro (12.9-inch) 3rd Generation 1 of 3

NOTES: UNLESS OTHERWISE SPECIFIED:

- 1 DO NOT OBSTRUCT ACOUSTIC OPENINGS: REAR MIC, SIDE MICS, FRONT MIC, SPEAKERS
- 2 DO NOT OBSTRUCT REAR CAMERA & REAR FLASH
- 3 DO NOT OBSTRUCT AMBIENT LIGHT SENSOR
- 4 DO NOT OBSTRUCT IR CAMERA, FLOOD ILLUMINATOR, FRONT CAMERA & DOT PROJECTOR
- 5 DO NOT HAVE METAL CONTACT WITH DEVICE COVER GLASS

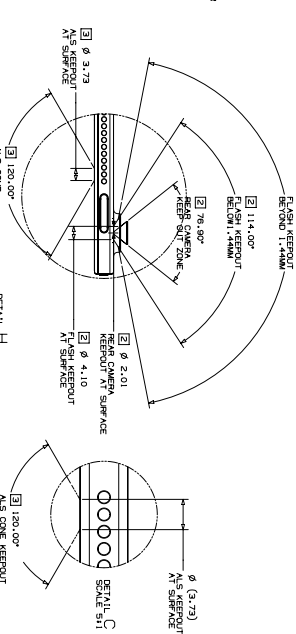
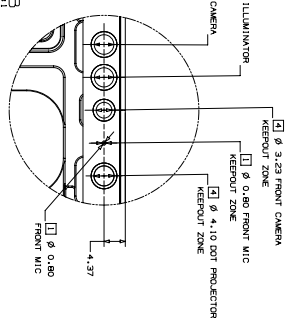
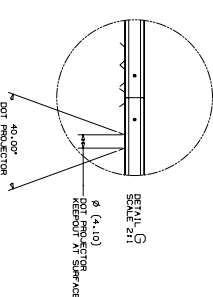
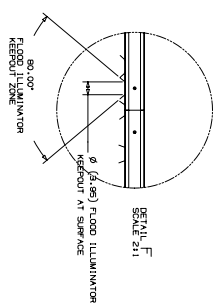
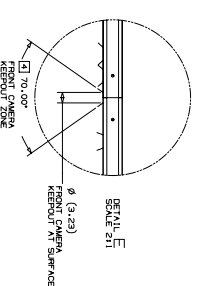
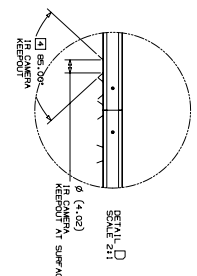
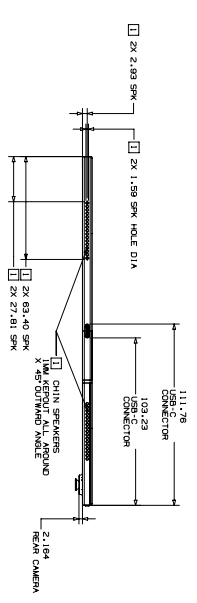
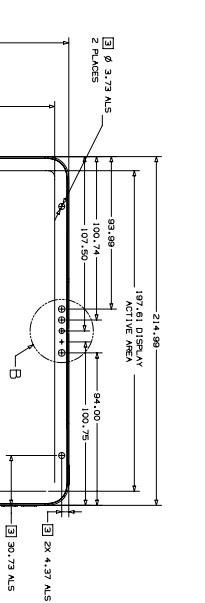
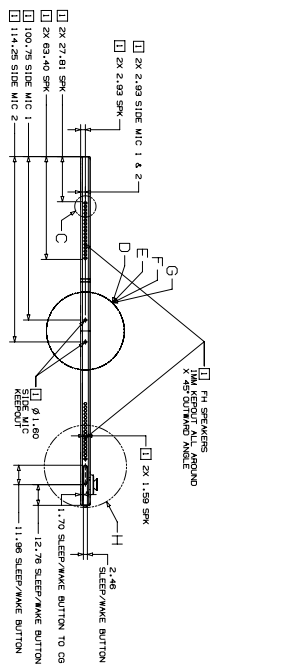

| METRIC | | Apple Inc. | |
|--|----------|------------|----------|
| DATE: | 10/27/18 | REV: | 04 |
| BY: | ... | CHKD: | ... |
| APPV: | ... | DATE: | 10/27/18 |
| PART NAME: iPad Pro (12.9-inch) 3rd Generation | | | |
| DESCRIPTION: ... | | | |
| MATERIAL: NONE | | | |
| FINISH: NONE | | | |
| TOLERANCE: ± 0.25 | | | |
| SURFACE FINISH: NONE | | | |
| DIMENSIONS: INCHES (1/16) | | | |

- 1 DO NOT OBSTRUCT ACOUSTIC OPENINGS: REAR MIC, SIDE MICS, FRONT MIC, SPEAKERS
- 2 DO NOT OBSTRUCT REAR CAMERA & REAR FLASH
- 3 DO NOT OBSTRUCT AMBIENT LIGHT SENSOR
- 4 DO NOT OBSTRUCT IR CAMERA, FLOOD ILLUMINATION, FRONT CAMERA & DOT PROJECTOR
- 5 DO NOT HAVE METAL CONTACT WITH DEVICE COVER GLASS

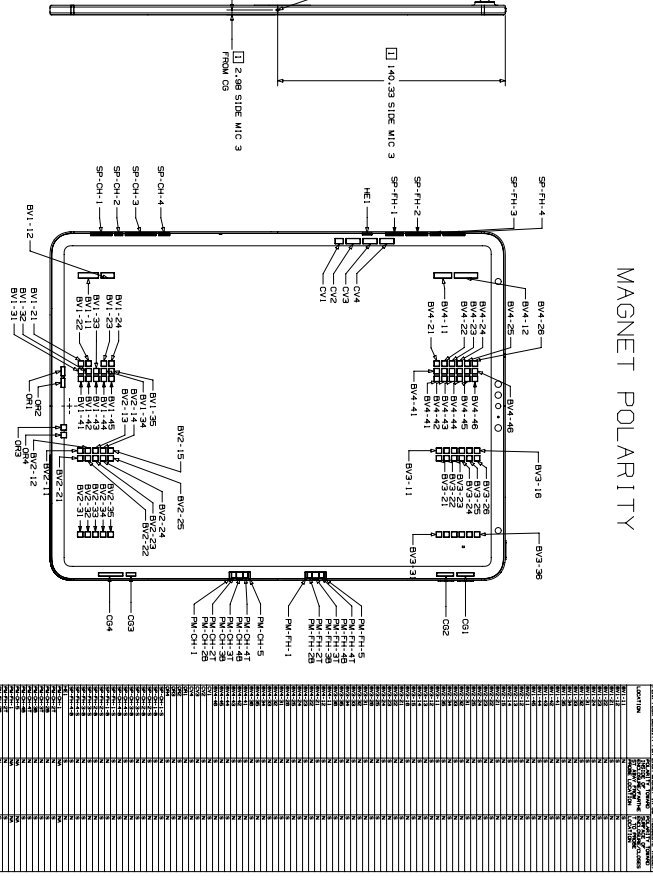
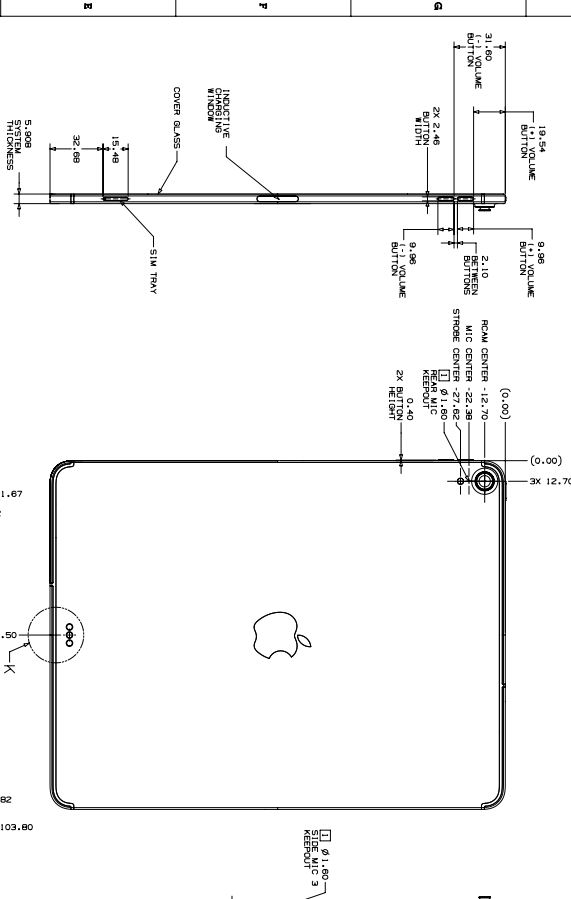

MAGNET POLARITY

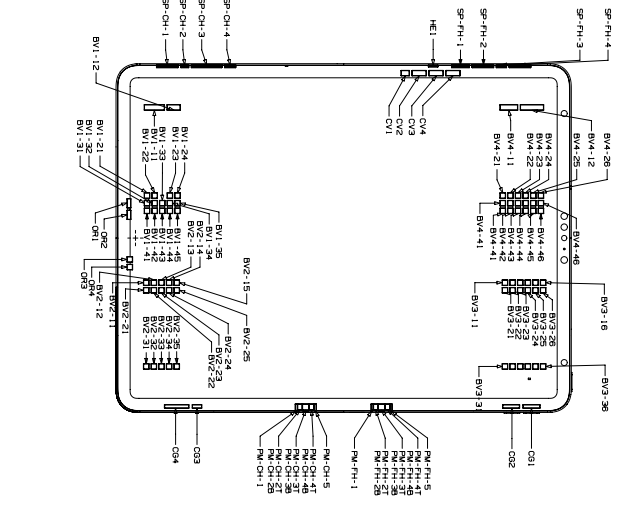

MAGNET AND HES DETAIL

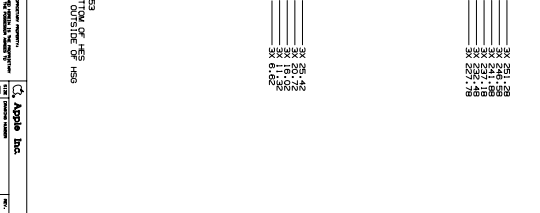
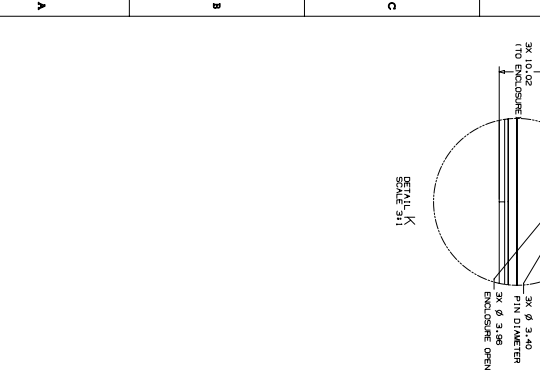
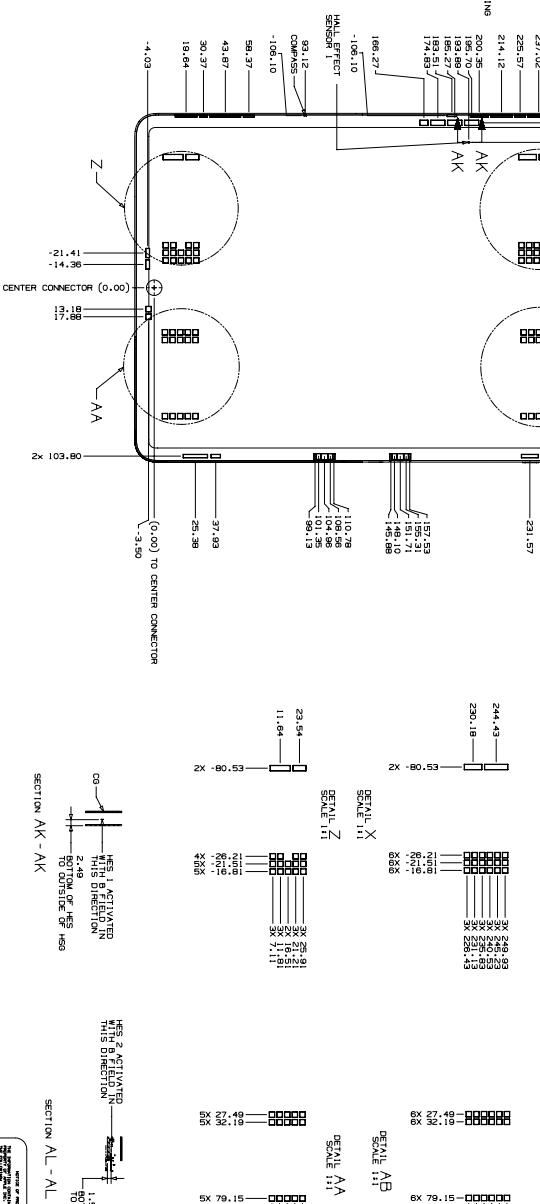

40.60 iPad Pro (12.9-inch) 3rd Generation 3 of 3

SECTION AND DETAIL INFORMATION

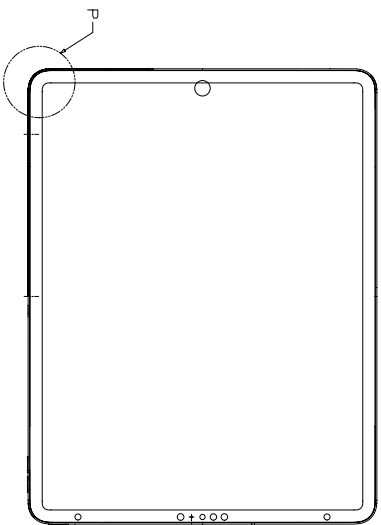

ANTENNA KEEP OUTS

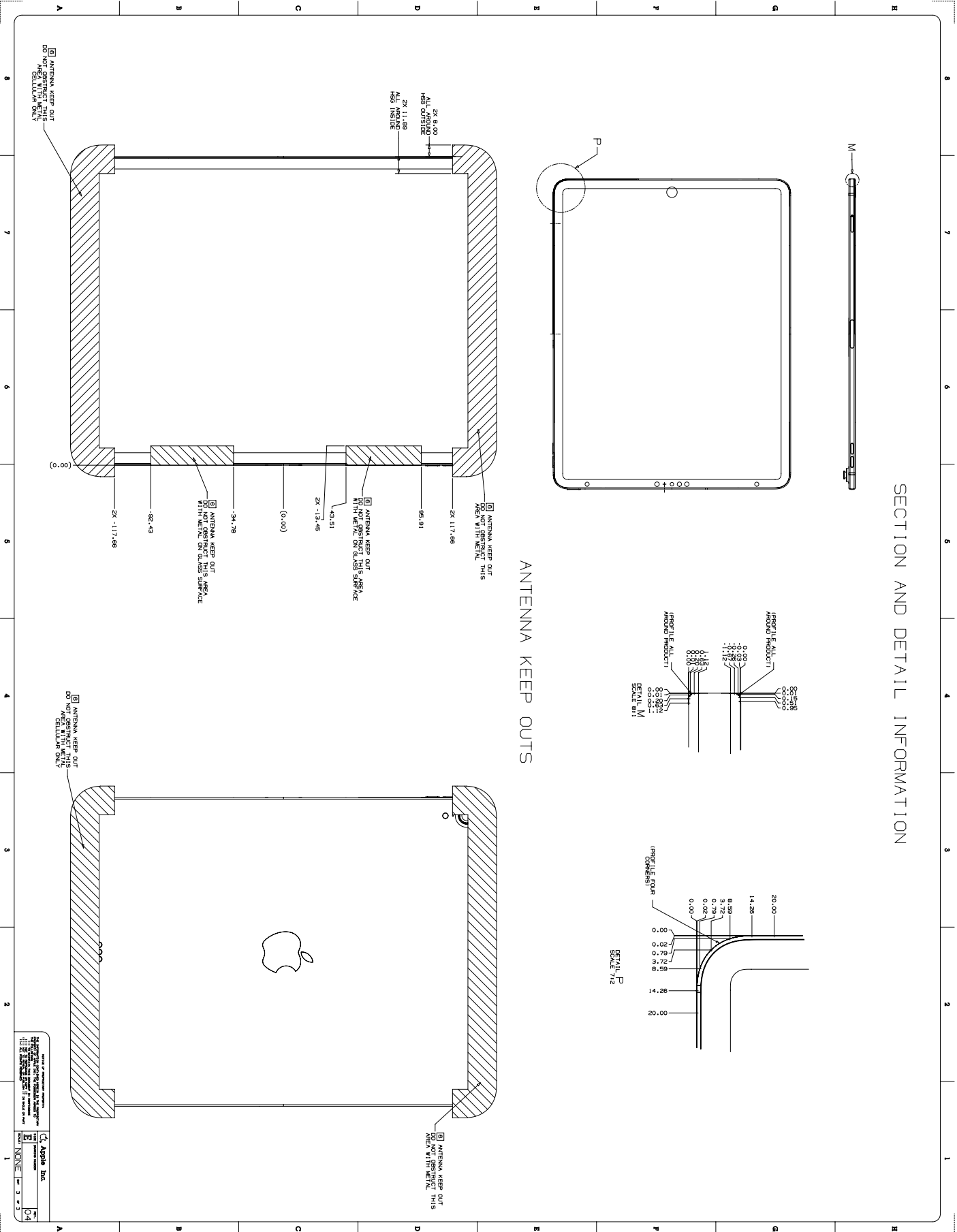
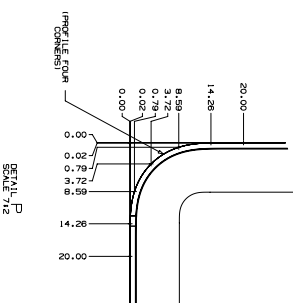
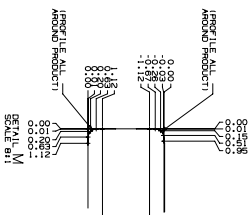

| | |
|-------------|--|
| DATE | 04 |
| VERSION | 04 |
| DESCRIPTION | ANTENNA KEEP OUTS |
| DESIGNED BY | NONE |
| CHECKED BY | NONE |
| APPROVED BY | NONE |
| SCALE | 1:1 |
| UNIT | MILLIMETERS |
| STANDARD | ANSI Y14.5 |
| PROJECT | 40.60 iPad Pro (12.9-inch) 3rd Generation |
| DRAWING NO. | 40.60 iPad Pro (12.9-inch) 3rd Generation 3 of 3 |
| REV. | 04 |
| DATE | 04 |

NOTES (UNLESS OTHERWISE SPECIFIED)

- 1 DO NOT OBSTRUCT ACoustic OPENINGS, REAR MIC, SIDE MICS, FRONT MIC, SPEAKERS
- 2 DO NOT OBSTRUCT REAR CAMERA & REAR FLASH
- 3 DO NOT OBSTRUCT AMBIENT LIGHT SENSOR
- 4 DO NOT OBSTRUCT IR CAMERA, FLOOD ILLUMINATOR, FRONT CAMERA & DOT PROJECTION
- 5 DO NOT HAVE METAL CONTACT WITH DEVICE COVER GLASS

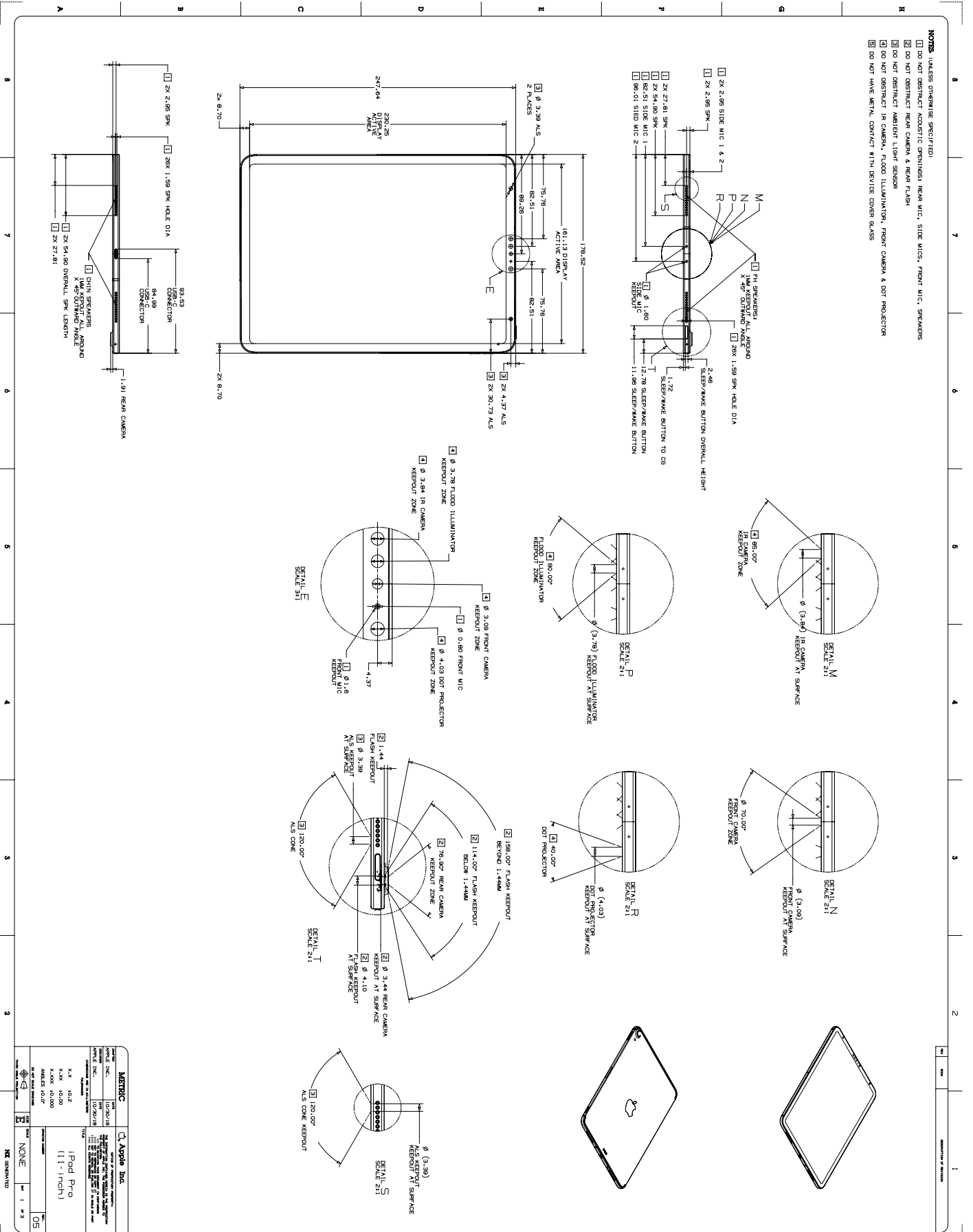

- NOTES** (UNLESS OTHERWISE SPECIFIED)
- 1 DO NOT OBSTRUCT ACOUSTIC OPENINGS: REAR MIC, SIDE MICS, FRONT MIC, SPEAKERS
 - 2 DO NOT OBSTRUCT REAR CAMERA & REAR FLASH
 - 3 DO NOT OBSTRUCT AMBIENT LIGHT SENSOR
 - 4 DO NOT OBSTRUCT IR CAMERA, FLUOR ILLUMINATION, FRONT CAMERA & DOT PROJECTOR
 - 5 DO NOT HAVE METAL CONTACT WITH DEVICE COVER GLASS

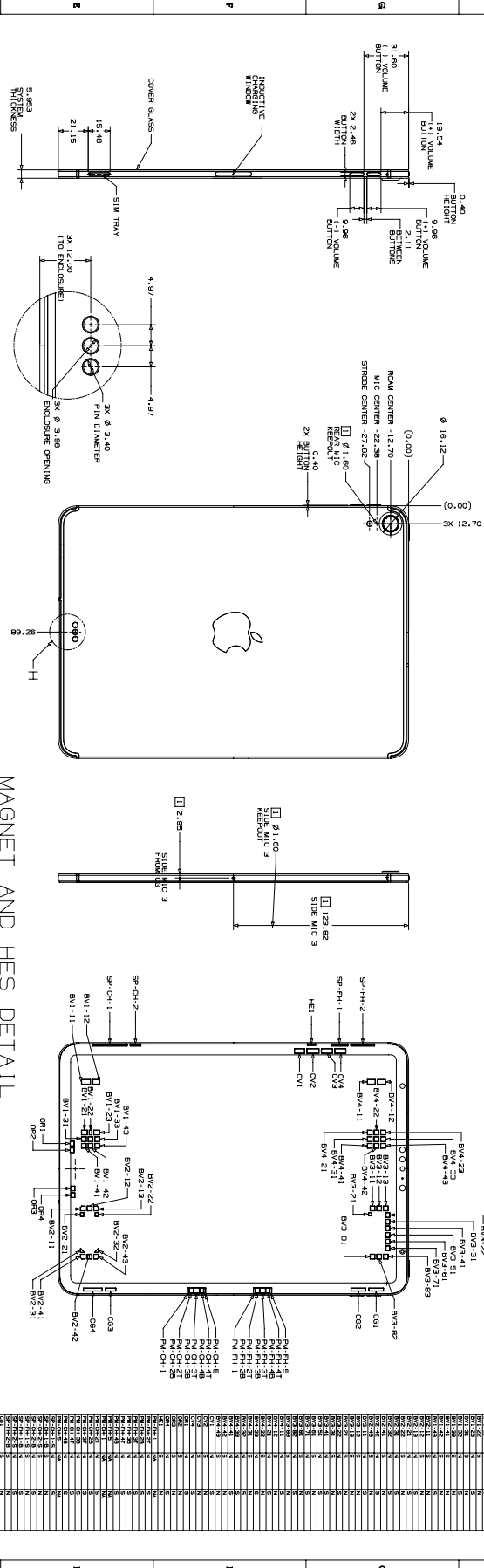

MAGNETS POLARITY

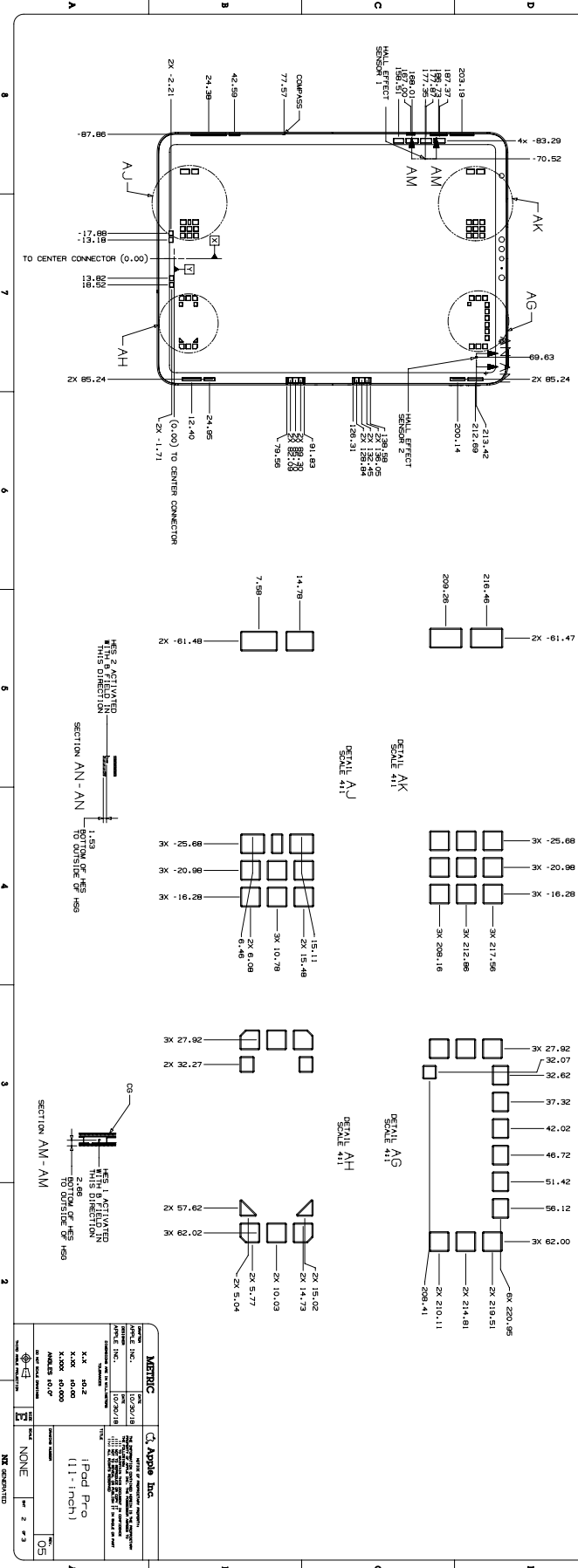
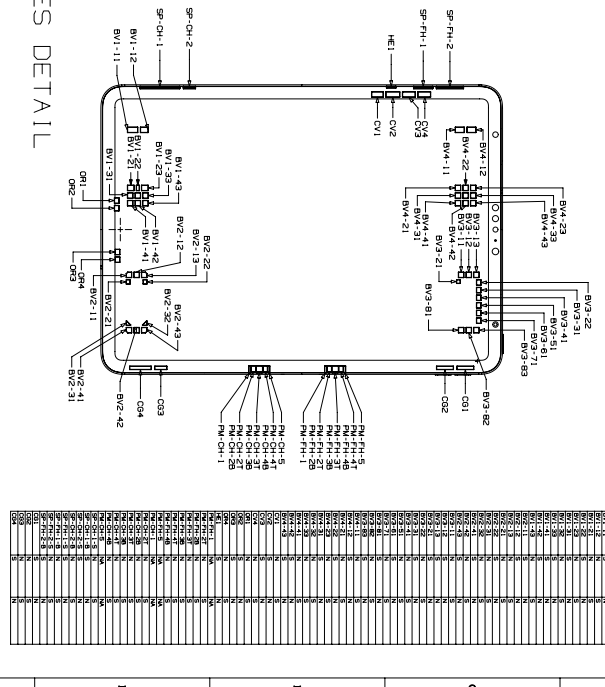

| LOCATION | IDENTIFICATION | DESCRIPTION |
|----------|----------------|-------------|
| BV-1-12 | VOICE COIL | SPK CH 1 |
| BV-1-13 | VOICE COIL | SPK CH 2 |
| BV-1-14 | VOICE COIL | SPK CH 3 |
| BV-1-15 | VOICE COIL | SPK CH 4 |
| BV-1-16 | VOICE COIL | SPK CH 5 |
| BV-1-17 | VOICE COIL | SPK CH 6 |
| BV-1-18 | VOICE COIL | SPK CH 7 |
| BV-1-19 | VOICE COIL | SPK CH 8 |
| BV-1-20 | VOICE COIL | SPK CH 9 |
| BV-1-21 | VOICE COIL | SPK CH 10 |
| BV-1-22 | VOICE COIL | SPK CH 11 |
| BV-2-12 | VOICE COIL | SPK CH 12 |
| BV-2-13 | VOICE COIL | SPK CH 13 |
| BV-2-14 | VOICE COIL | SPK CH 14 |
| BV-2-15 | VOICE COIL | SPK CH 15 |
| BV-2-16 | VOICE COIL | SPK CH 16 |
| BV-2-17 | VOICE COIL | SPK CH 17 |
| BV-2-18 | VOICE COIL | SPK CH 18 |
| BV-2-19 | VOICE COIL | SPK CH 19 |
| BV-2-20 | VOICE COIL | SPK CH 20 |
| BV-2-21 | VOICE COIL | SPK CH 21 |
| BV-2-22 | VOICE COIL | SPK CH 22 |
| BV-3-12 | VOICE COIL | SPK CH 23 |
| BV-3-13 | VOICE COIL | SPK CH 24 |
| BV-3-14 | VOICE COIL | SPK CH 25 |
| BV-3-15 | VOICE COIL | SPK CH 26 |
| BV-3-16 | VOICE COIL | SPK CH 27 |
| BV-3-17 | VOICE COIL | SPK CH 28 |
| BV-3-18 | VOICE COIL | SPK CH 29 |
| BV-3-19 | VOICE COIL | SPK CH 30 |
| BV-3-20 | VOICE COIL | SPK CH 31 |
| BV-3-21 | VOICE COIL | SPK CH 32 |
| BV-3-22 | VOICE COIL | SPK CH 33 |
| BV-4-23 | VOICE COIL | SPK CH 34 |
| BV-4-24 | VOICE COIL | SPK CH 35 |
| BV-4-25 | VOICE COIL | SPK CH 36 |
| BV-4-26 | VOICE COIL | SPK CH 37 |
| BV-4-27 | VOICE COIL | SPK CH 38 |
| BV-4-28 | VOICE COIL | SPK CH 39 |
| BV-4-29 | VOICE COIL | SPK CH 40 |
| BV-4-30 | VOICE COIL | SPK CH 41 |
| BV-4-31 | VOICE COIL | SPK CH 42 |
| BV-4-32 | VOICE COIL | SPK CH 43 |
| BV-4-33 | VOICE COIL | SPK CH 44 |
| BV-4-34 | VOICE COIL | SPK CH 45 |
| BV-4-35 | VOICE COIL | SPK CH 46 |
| BV-4-36 | VOICE COIL | SPK CH 47 |
| BV-4-37 | VOICE COIL | SPK CH 48 |
| BV-4-38 | VOICE COIL | SPK CH 49 |
| BV-4-39 | VOICE COIL | SPK CH 50 |
| BV-4-40 | VOICE COIL | SPK CH 51 |
| BV-4-41 | VOICE COIL | SPK CH 52 |
| BV-4-42 | VOICE COIL | SPK CH 53 |
| BV-4-43 | VOICE COIL | SPK CH 54 |
| BV-5-21 | VOICE COIL | SPK CH 55 |
| BV-5-22 | VOICE COIL | SPK CH 56 |
| BV-5-23 | VOICE COIL | SPK CH 57 |
| BV-5-24 | VOICE COIL | SPK CH 58 |
| BV-5-25 | VOICE COIL | SPK CH 59 |
| BV-5-26 | VOICE COIL | SPK CH 60 |
| BV-5-27 | VOICE COIL | SPK CH 61 |
| BV-5-28 | VOICE COIL | SPK CH 62 |
| BV-5-29 | VOICE COIL | SPK CH 63 |
| BV-5-30 | VOICE COIL | SPK CH 64 |
| BV-5-31 | VOICE COIL | SPK CH 65 |
| BV-5-32 | VOICE COIL | SPK CH 66 |
| BV-5-33 | VOICE COIL | SPK CH 67 |
| BV-5-34 | VOICE COIL | SPK CH 68 |
| BV-5-35 | VOICE COIL | SPK CH 69 |
| BV-5-36 | VOICE COIL | SPK CH 70 |
| BV-5-37 | VOICE COIL | SPK CH 71 |
| BV-5-38 | VOICE COIL | SPK CH 72 |
| BV-5-39 | VOICE COIL | SPK CH 73 |
| BV-5-40 | VOICE COIL | SPK CH 74 |
| BV-5-41 | VOICE COIL | SPK CH 75 |
| BV-5-42 | VOICE COIL | SPK CH 76 |
| BV-5-43 | VOICE COIL | SPK CH 77 |
| BV-5-44 | VOICE COIL | SPK CH 78 |
| BV-5-45 | VOICE COIL | SPK CH 79 |
| BV-5-46 | VOICE COIL | SPK CH 80 |
| BV-5-47 | VOICE COIL | SPK CH 81 |
| BV-5-48 | VOICE COIL | SPK CH 82 |
| BV-5-49 | VOICE COIL | SPK CH 83 |
| BV-5-50 | VOICE COIL | SPK CH 84 |
| BV-5-51 | VOICE COIL | SPK CH 85 |
| BV-5-52 | VOICE COIL | SPK CH 86 |
| BV-5-53 | VOICE COIL | SPK CH 87 |
| BV-5-54 | VOICE COIL | SPK CH 88 |
| BV-5-55 | VOICE COIL | SPK CH 89 |
| BV-5-56 | VOICE COIL | SPK CH 90 |
| BV-5-57 | VOICE COIL | SPK CH 91 |
| BV-5-58 | VOICE COIL | SPK CH 92 |
| BV-5-59 | VOICE COIL | SPK CH 93 |
| BV-5-60 | VOICE COIL | SPK CH 94 |
| BV-5-61 | VOICE COIL | SPK CH 95 |
| BV-5-62 | VOICE COIL | SPK CH 96 |
| BV-5-63 | VOICE COIL | SPK CH 97 |
| BV-5-64 | VOICE COIL | SPK CH 98 |
| BV-5-65 | VOICE COIL | SPK CH 99 |
| BV-5-66 | VOICE COIL | SPK CH 100 |

SECTION AND DETAIL INFORMATION

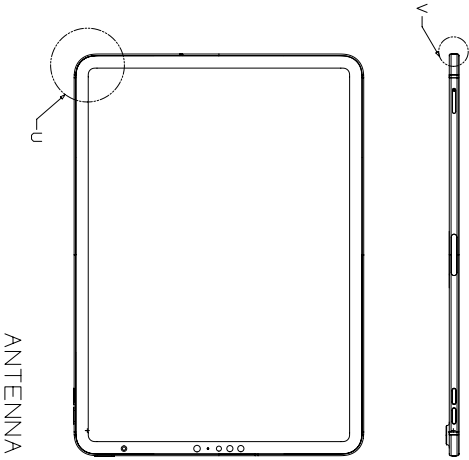

ANTENNA KEEP OUTS

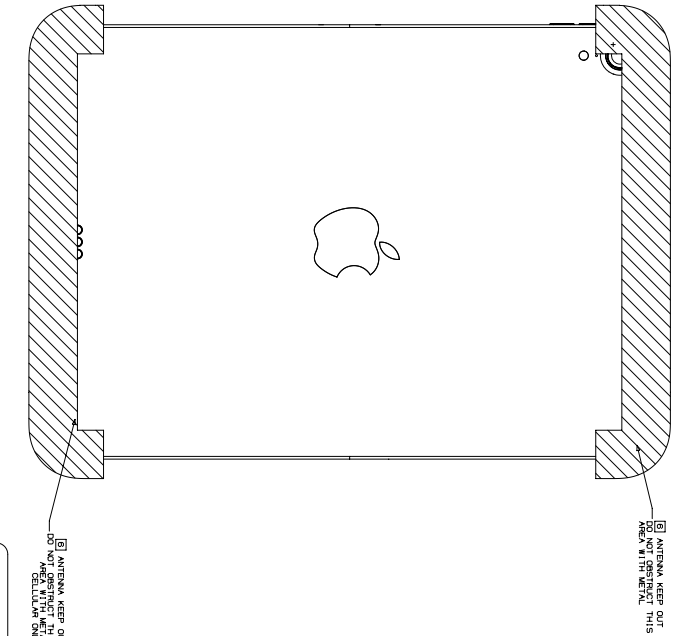
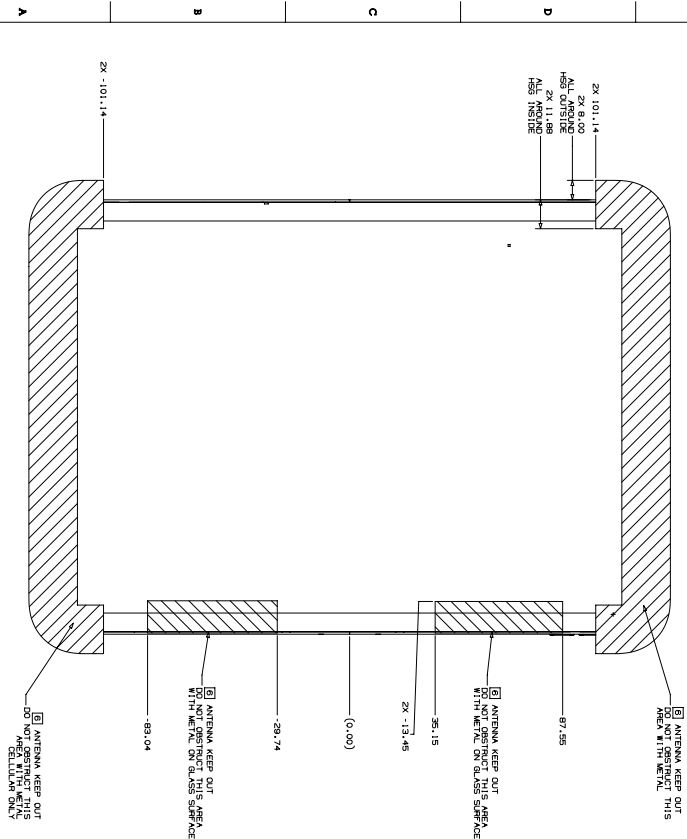
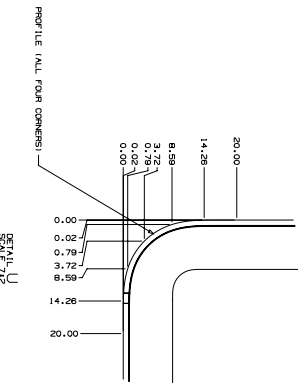
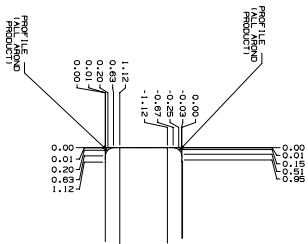

| | |
|--------------------------------|--------------------------------|
| <p>Apple Inc. Confidential</p> | |
| <p>Apple Inc. Confidential</p> | <p>Apple Inc. Confidential</p> |
| <p>Apple Inc. Confidential</p> | <p>Apple Inc. Confidential</p> |
| <p>Apple Inc. Confidential</p> | <p>Apple Inc. Confidential</p> |
| <p>Apple Inc. Confidential</p> | <p>Apple Inc. Confidential</p> |
| <p>Apple Inc. Confidential</p> | <p>Apple Inc. Confidential</p> |
| <p>Apple Inc. Confidential</p> | <p>Apple Inc. Confidential</p> |
| <p>Apple Inc. Confidential</p> | <p>Apple Inc. Confidential</p> |
| <p>Apple Inc. Confidential</p> | <p>Apple Inc. Confidential</p> |
| <p>Apple Inc. Confidential</p> | <p>Apple Inc. Confidential</p> |

40.64 iPad Pro (12.9-inch) 2nd Generation with Wi-Fi

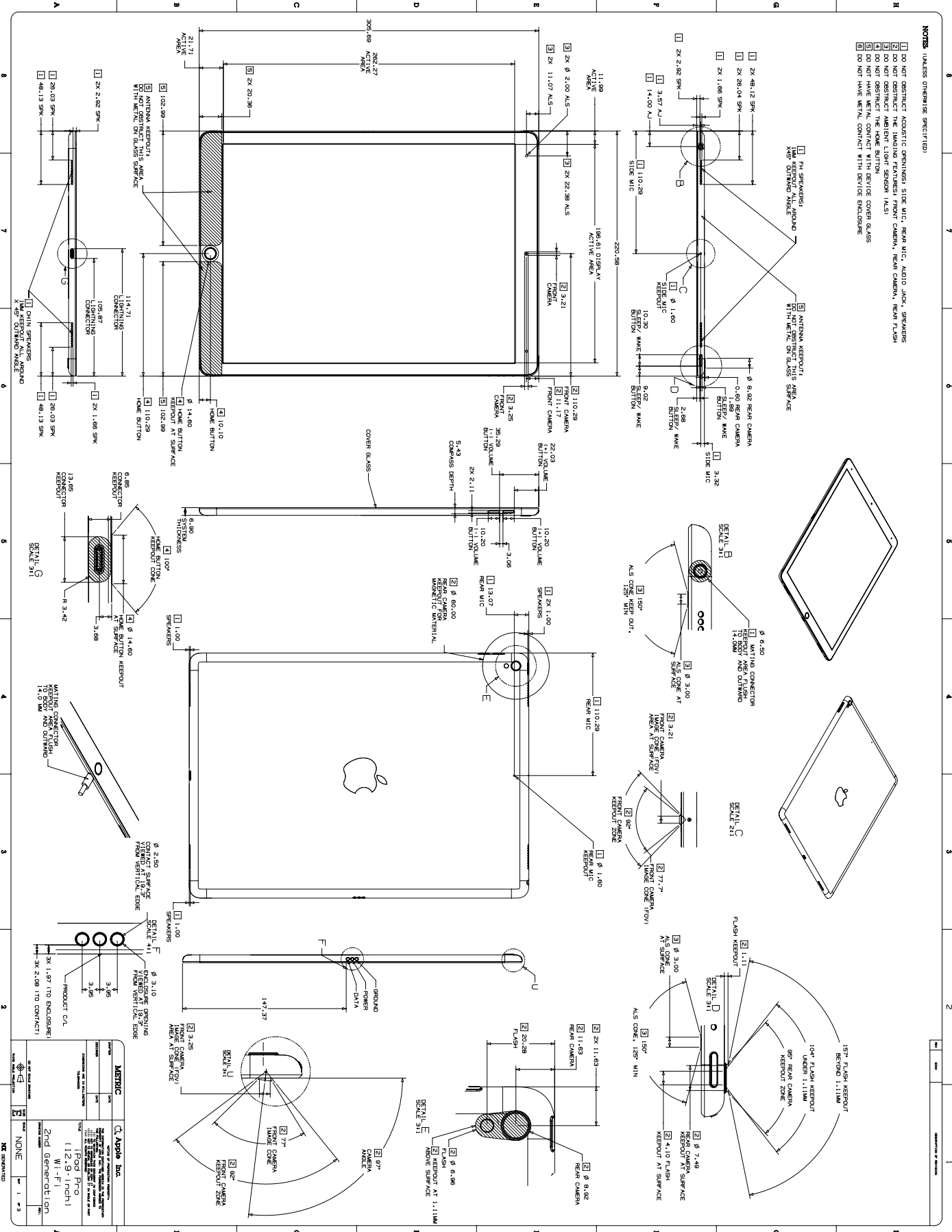

40.65 iPad Pro (12.9-inch) 2nd Generation with Wi-Fi + Cellular

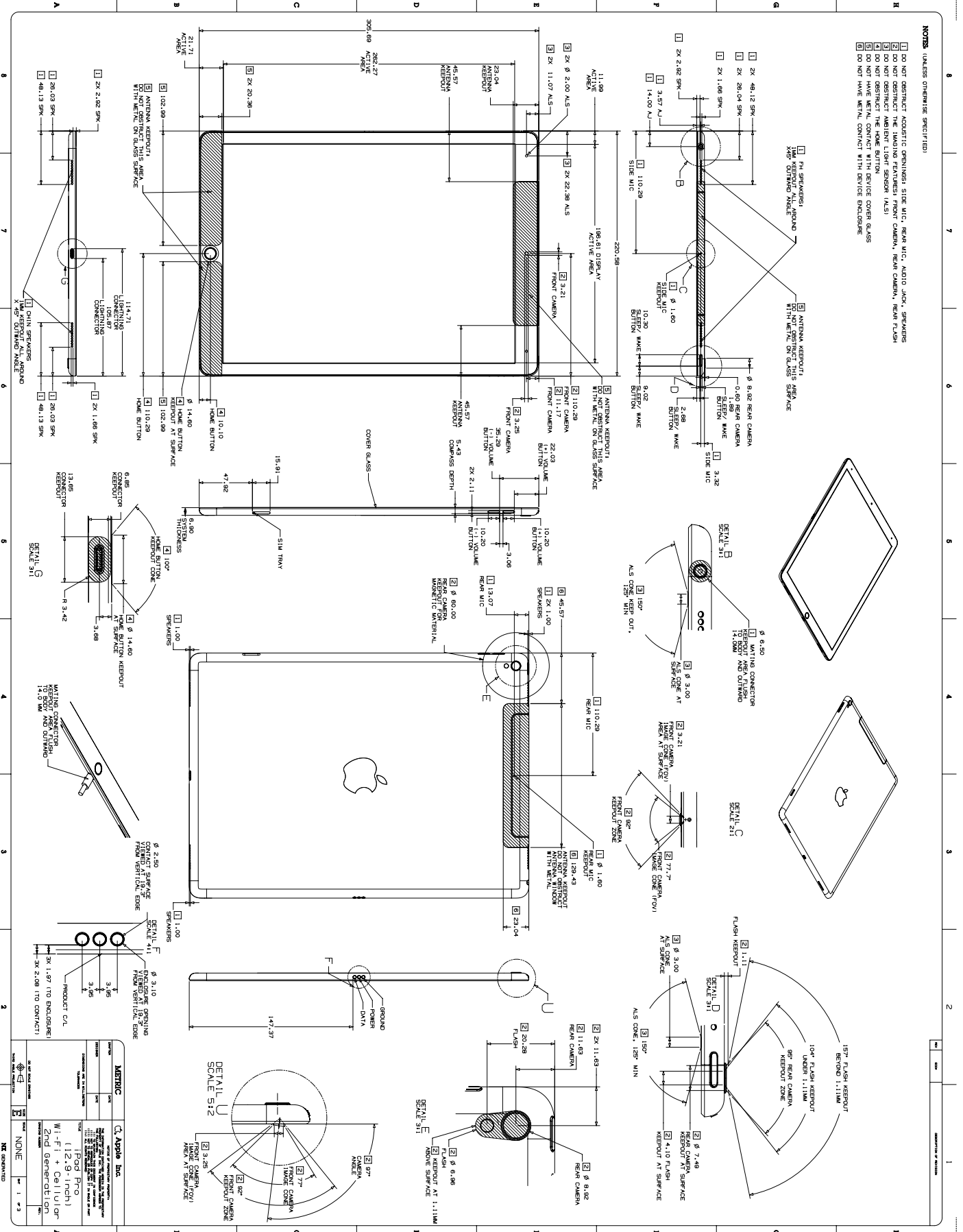

40.68 iPad Pro (10.5-inch) with Wi-Fi

- NOTES**
- 1 DO NOT OBSTRUCT ACOUSTIC GRILLINGS, SLIDE MIC, REAR MIC, AUDIO JACK, SPEAKERS
 - 2 DO NOT OBSTRUCT THE IMAGING FEATURES FRONT CAMERA, REAR CAMERA, REAR FLASH
 - 3 DO NOT OBSTRUCT THE AMBIENT LIGHT SENSOR (ALS)
 - 4 DO NOT OBSTRUCT THE HOME BUTTON
 - 5 DO NOT HAVE METAL CONTACT WITH DEVICE COVER GLASS

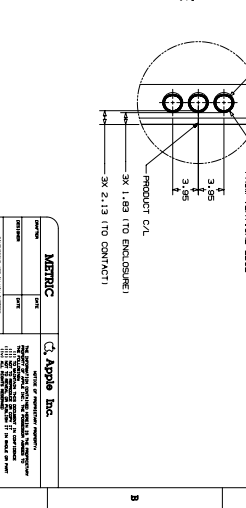
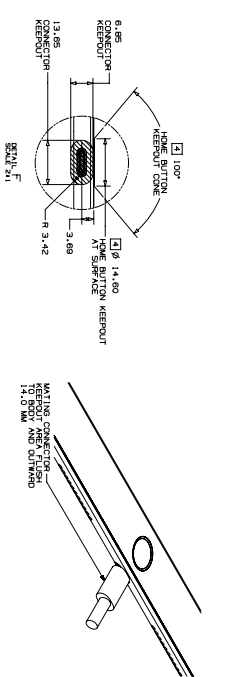
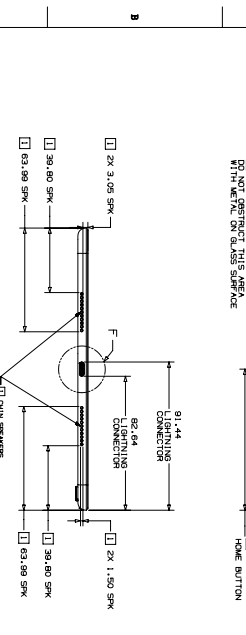
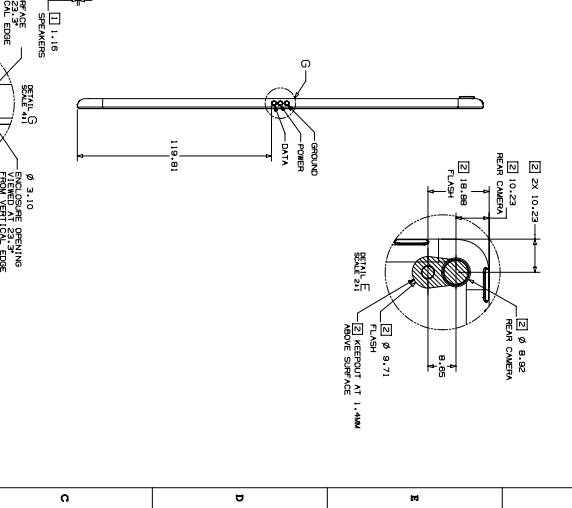
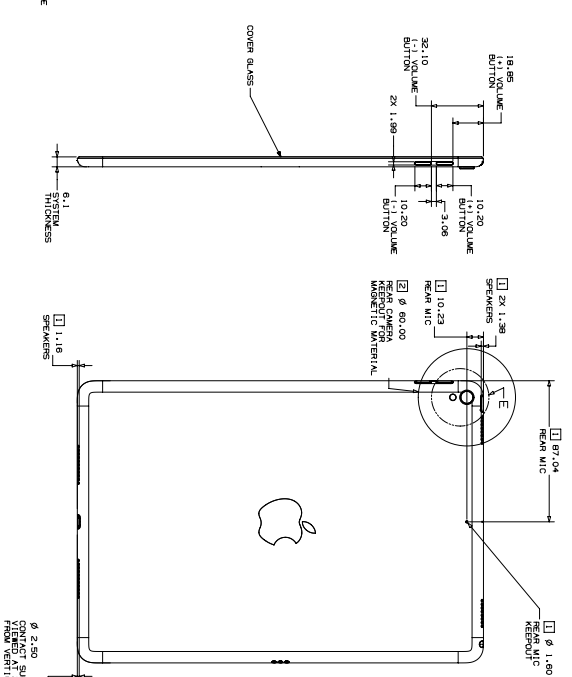
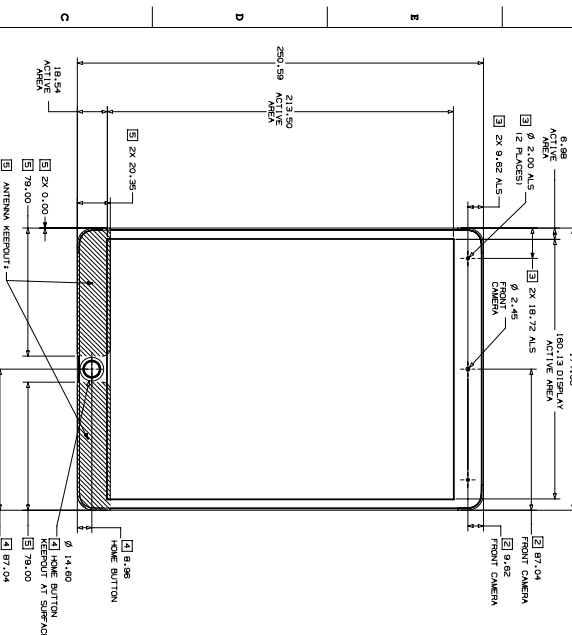
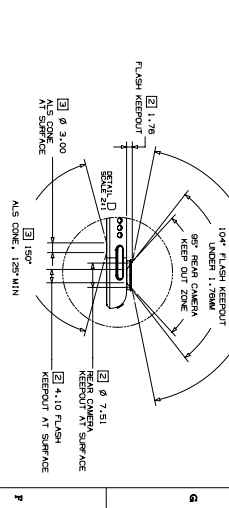
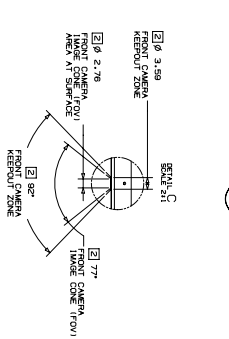
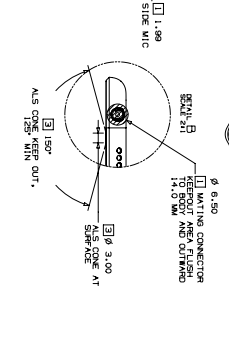
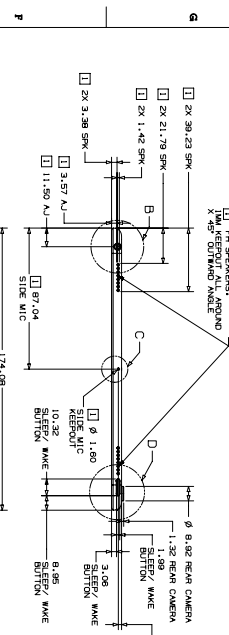
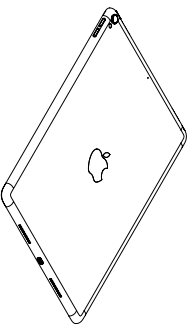
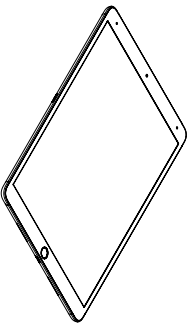

| METRIC | | Apple Inc. | |
|------------|---------|------------|---------|
| UNIT | VALUE | UNIT | VALUE |
| MILLIMETER | 0.01 | INCH | 0.0005 |
| MILLIMETER | 0.02 | INCH | 0.0008 |
| MILLIMETER | 0.05 | INCH | 0.0020 |
| MILLIMETER | 0.10 | INCH | 0.0040 |
| MILLIMETER | 0.20 | INCH | 0.0080 |
| MILLIMETER | 0.50 | INCH | 0.0200 |
| MILLIMETER | 1.00 | INCH | 0.0394 |
| MILLIMETER | 2.00 | INCH | 0.0787 |
| MILLIMETER | 5.00 | INCH | 0.1969 |
| MILLIMETER | 10.00 | INCH | 0.3937 |
| MILLIMETER | 20.00 | INCH | 0.7874 |
| MILLIMETER | 50.00 | INCH | 1.9685 |
| MILLIMETER | 100.00 | INCH | 3.9370 |
| MILLIMETER | 250.00 | INCH | 9.8425 |
| MILLIMETER | 500.00 | INCH | 19.6850 |
| MILLIMETER | 1000.00 | INCH | 39.3700 |

40.70 iPad Pro (10.5-inch) Magnet/Hall Effect Sensors 1 of 2

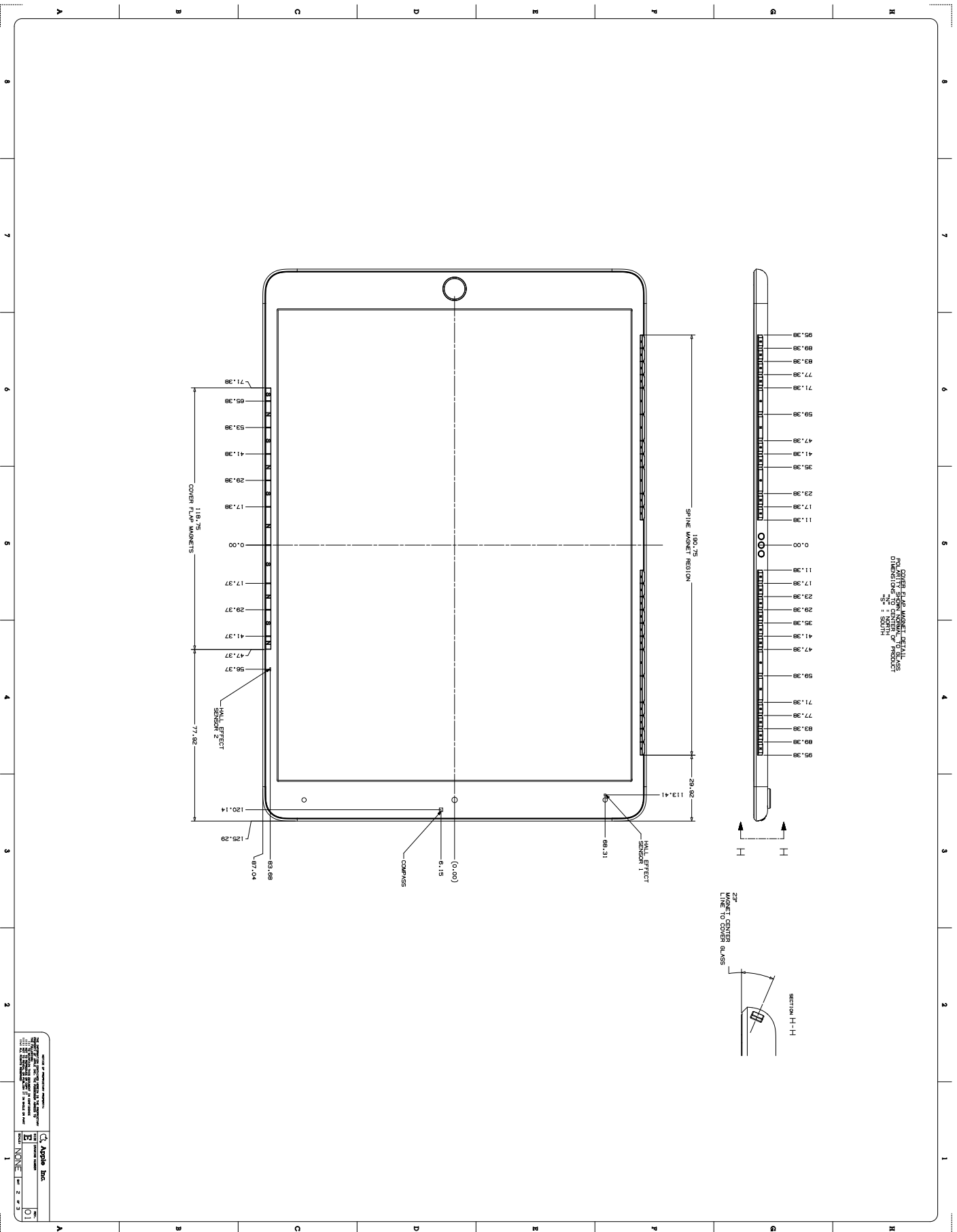

40.71 iPad Pro (10.5-inch) Magnet/Hall Effect Sensors 2 of 2

SECTION AND DETAIL INFORMATION

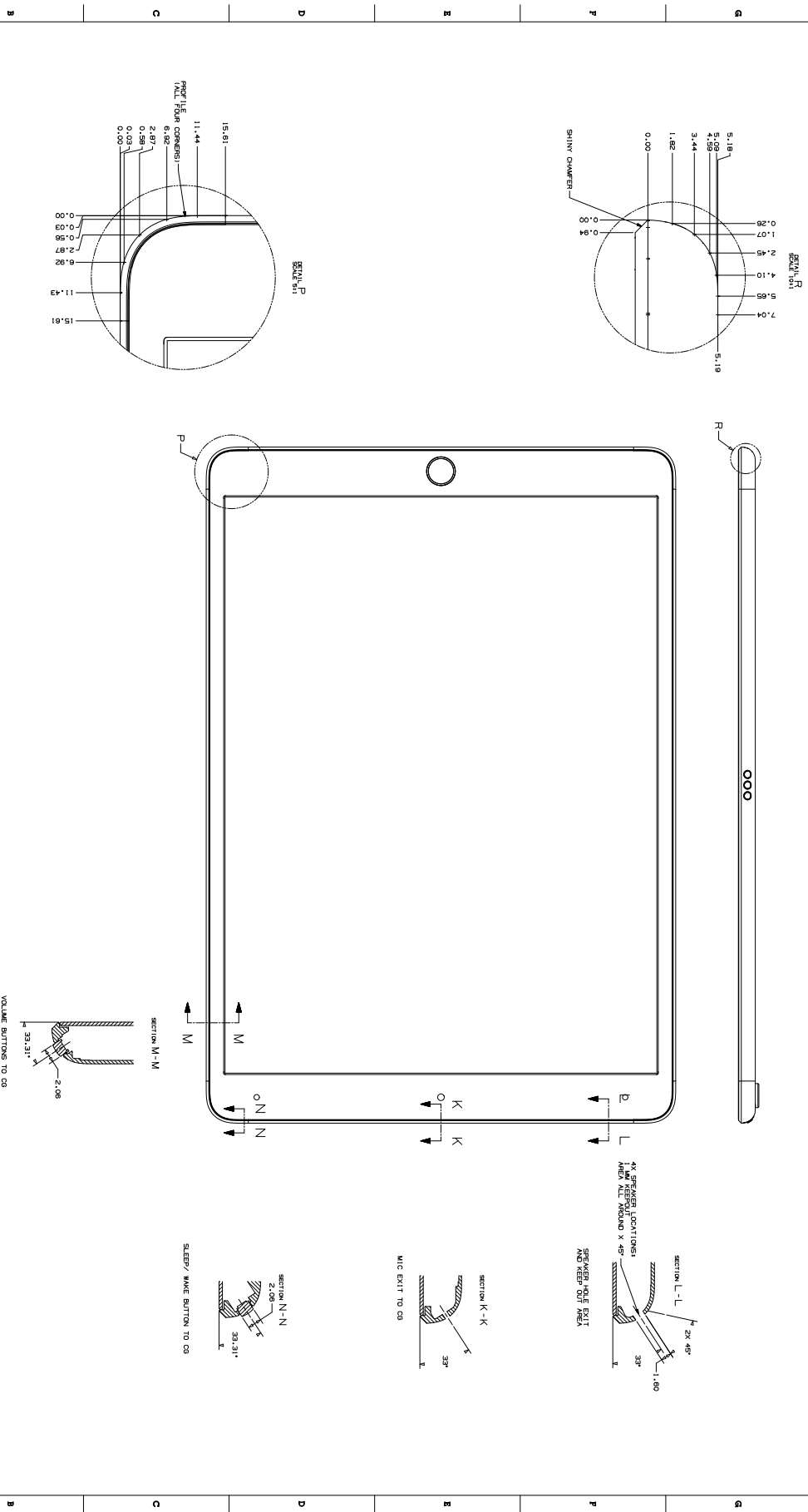

| | | |
|------------------------|-----|------------|
| SECTION OF INFORMATION | | Apple Inc. |
| DATE | REV | 01 |
| 1 | 2 | 3 |
| NONE | | 2 |

40.73 iPad (5th and 6th generation) Magnet/Hall Effect Sensors 1 of 2

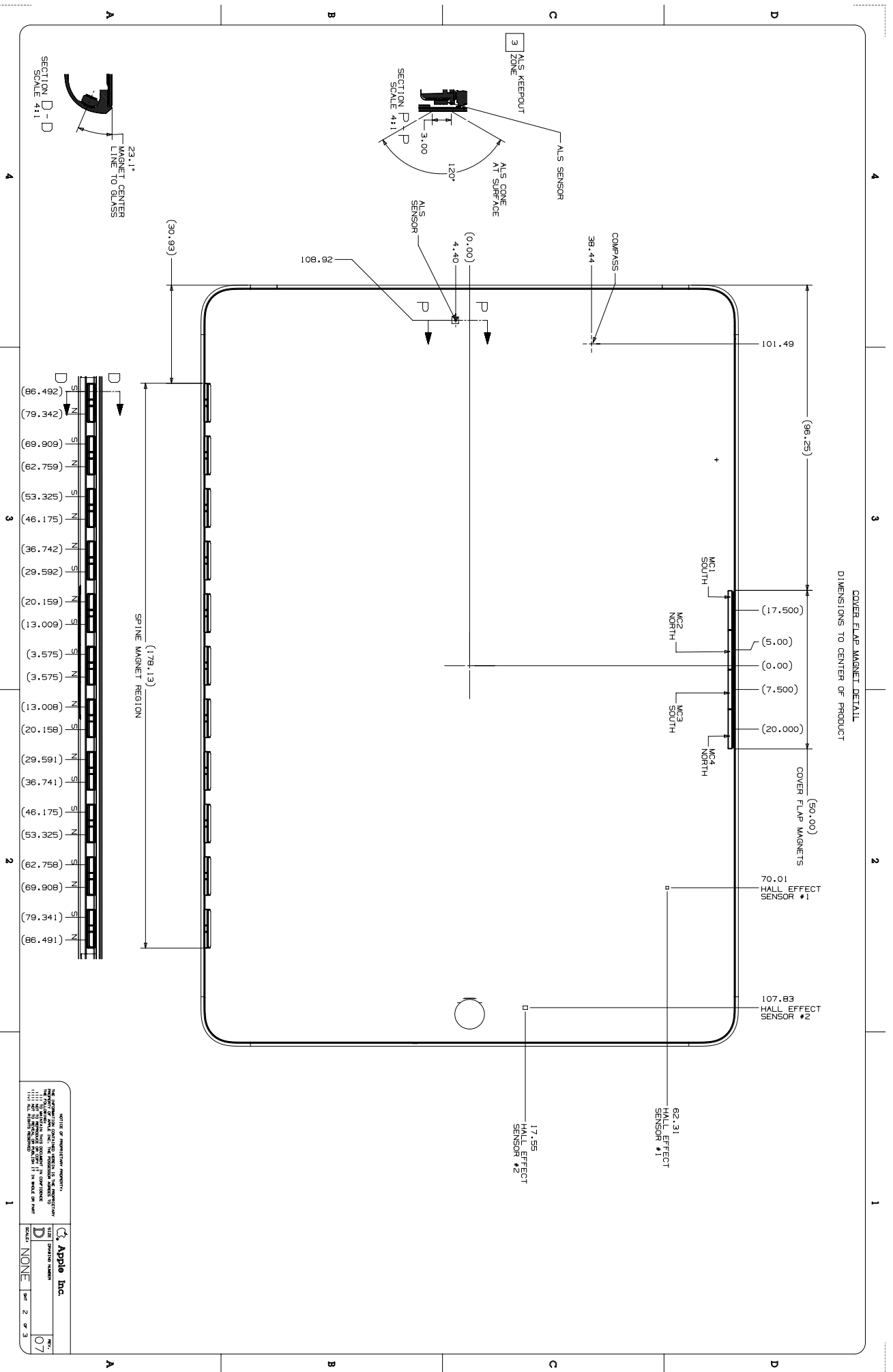

| | | | |
|---|--|---------------------|---------------|
| DATE OF ORIGINAL DESIGN | | Apple Inc. | |
| THE INFORMATION CONTAINED HEREIN IS THE PROPERTY OF APPLE INC. AND IS TO BE USED ONLY FOR THE PURPOSES SPECIFIED HEREIN. IT IS MADE ON PAPER. | | TYPE (Drawing Name) | REV. (07) |
| DRAWING NUMBER: D | | ISSUES: NONE | SHEET: 2 OF 3 |

40.74 iPad (5th and 6th generation) Magnet/Hall Effect Sensors 2 of 2

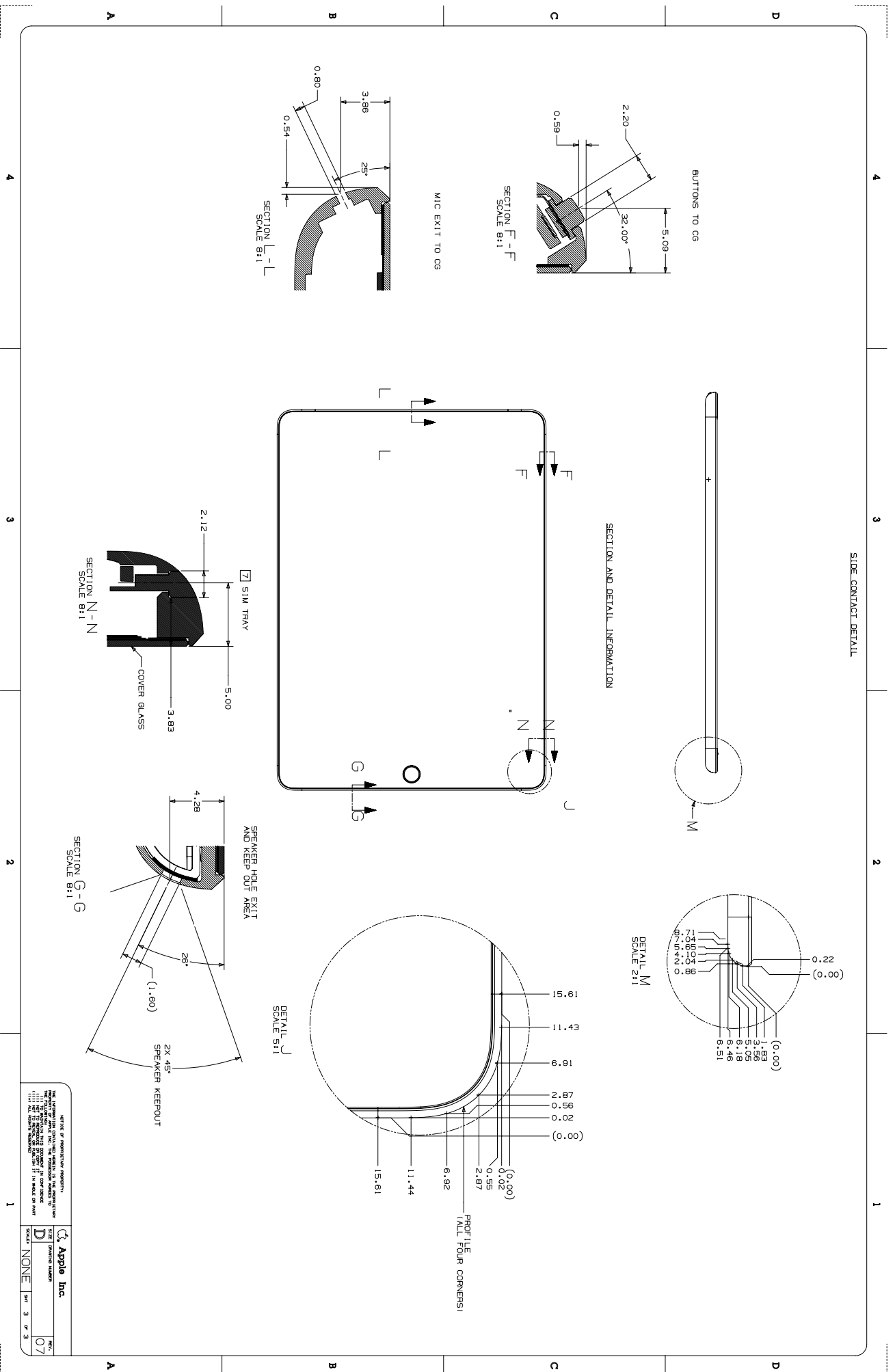

| | | |
|--|---|---|
| APPLE INC. HEADQUARTERS 100 APPLE PARKWAY CUPERTINO, CA 95014 TEL: 415.924.6457 FAX: 415.924.6457 © 2010 APPLE INC. ALL RIGHTS RESERVED. | | DATE: 07/11/10 DRAWING NO: 40.74 REVISION: 1 BY: [REDACTED] CHECKED: [REDACTED] |
| PART NO: 40.74 PART NAME: MAGNET/HALL EFFECT SENSORS 2 OF 2 PART TYPE: NONE | DRAWING NO: 40.74 REVISION: 1 BY: [REDACTED] CHECKED: [REDACTED] | SHEET: 3 OF 3 |

40.75 iPad Pro (9.7-inch) with Wi-Fi

NOTES

- 1 DO NOT OBSTRUCT ACOUSTIC OPENINGS; SIDE MIC, REAR MIC, AUDIO JACK, SPEAKERS
- 2 DO NOT OBSTRUCT IMAGING FEATURES: FRONT CAMERA, REAR CAMERA, REAR FLASH
- 3 DO NOT OBSTRUCT AMBIENT LIGHT SENSOR (ALS)
- 4 DO NOT OBSTRUCT THE HOME BUTTON
- 5 DO NOT OBSTRUCT GLASS WITH METAL
- 6 DO NOT OBSTRUCT ENCLOSURE WITH METAL

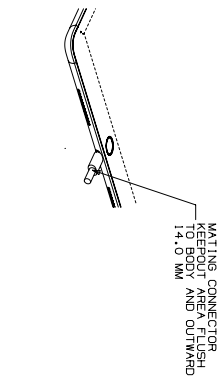
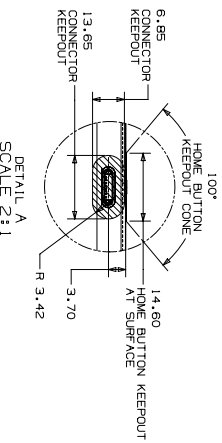
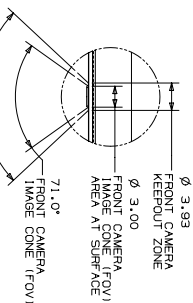
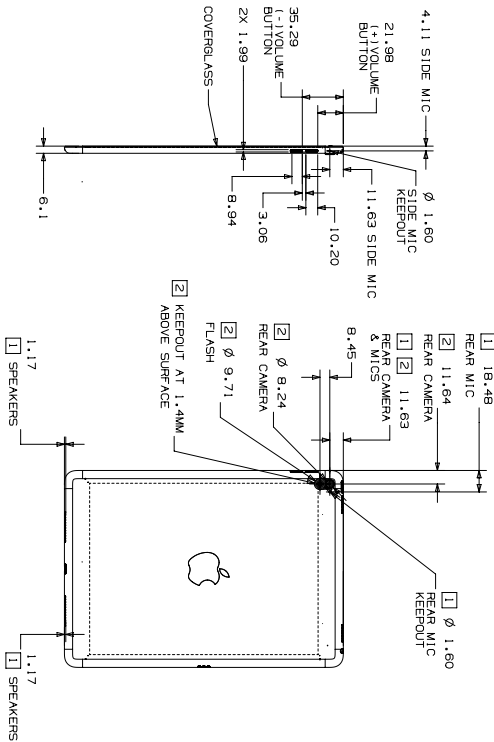
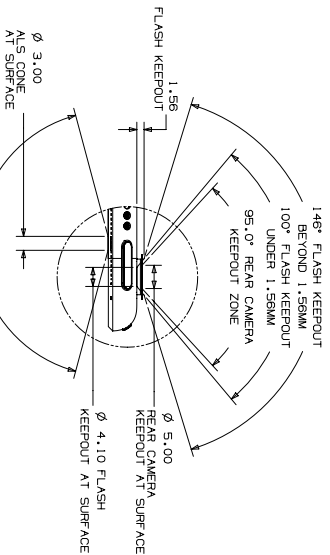
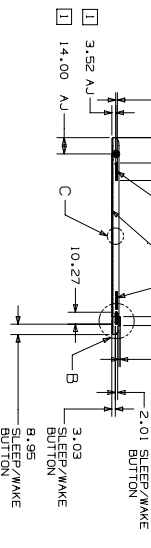
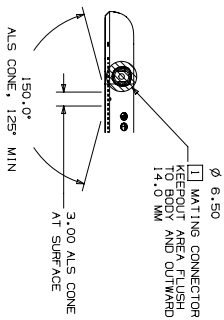
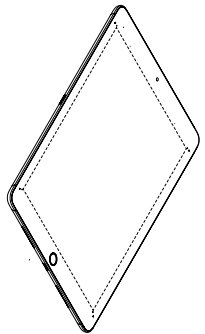
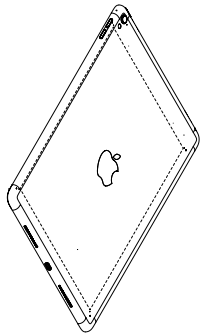

| | | | |
|---|--|---|--|
| <p>MERRIC</p> <p>DATE: 03/28/18 BY: [REDACTED] APPROVED BY: [REDACTED] APPROVED DATE: 03/28/18 DRAWING NO: 21 (ILLUSTRATIONS) TOLERANCES</p> | | <p>Apple Inc.</p> <p>DATE OF PRELIMINARY APPROVAL: 03/28/18 DATE OF FINAL APPROVAL: 03/28/18 DESIGNED BY: [REDACTED] DRAWN BY: [REDACTED] CHECKED BY: [REDACTED] DATE OF CHECK: [REDACTED] SCALE: NONE</p> | |
| <p>DO NOT SCALE DIMENSIONS</p> <p>HAND MADE REVISION</p> <p>NX GENERATED</p> | | <p>9.7-inch iPad Pro (9.7-inch) Wi-Fi</p> | |

40.76 iPad Pro (9.7-inch) with Wi-Fi + Cellular

- NOTES**
- 1 DO NOT OBSTRUCT ACOUSTIC OPENINGS: SIDE MIC, REAR MIC, AUDIO JACK, SPEAKERS
 - 2 DO NOT OBSTRUCT IMAGING FEATURES: FRONT CAMERA, REAR CAMERA, REAR FLASH
 - 3 DO NOT OBSTRUCT AMBIENT LIGHT SENSOR (ALS)
 - 4 DO NOT OBSTRUCT THE HOME BUTTON
 - 5 DO NOT OBSTRUCT GLASS WITH METAL
 - 6 DO NOT OBSTRUCT ENCLOSURE WITH METAL

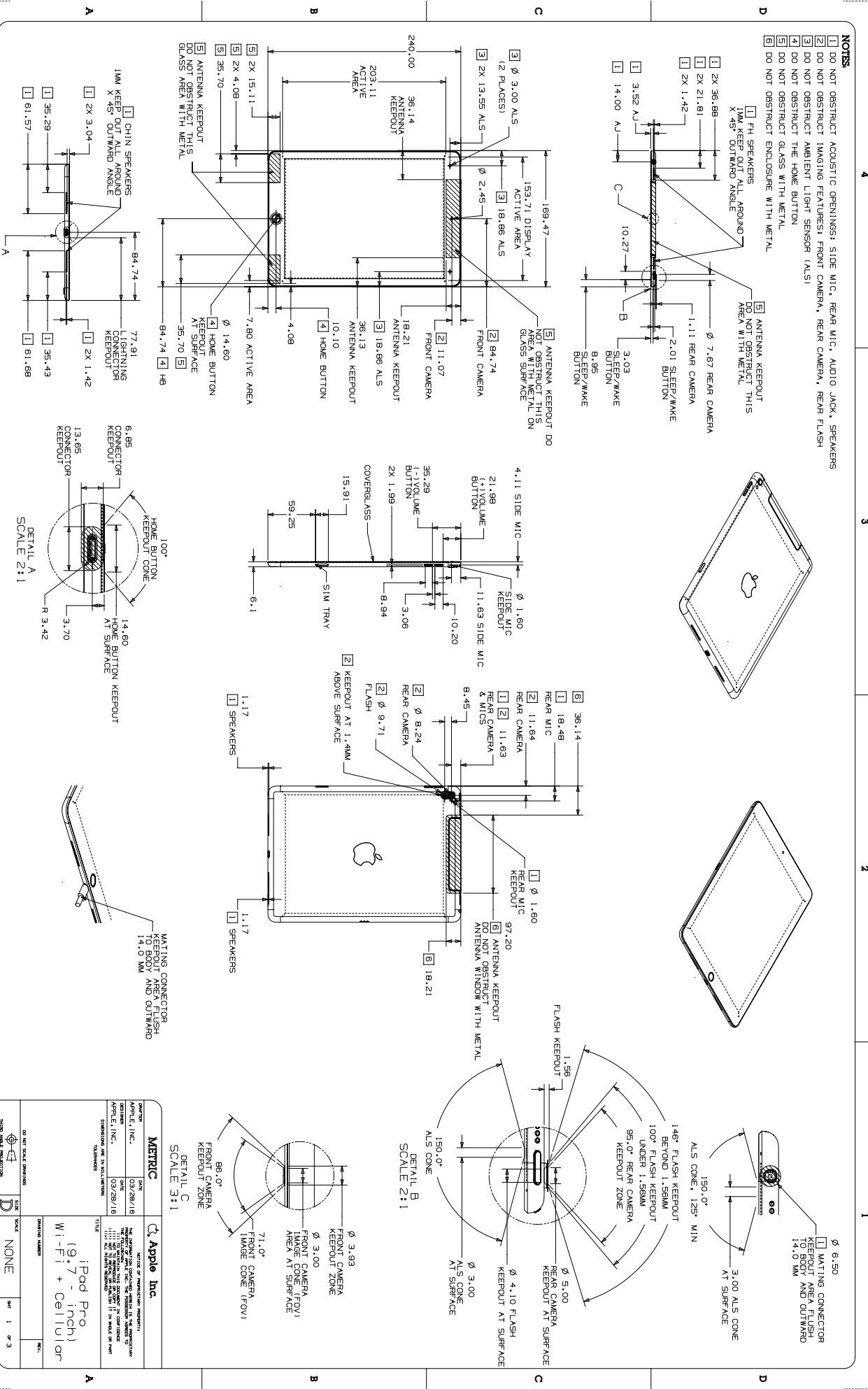

| | | | |
|---|-------------|-----------------------------------|---|
| METRIC | | Apple Inc. | |
| DATE | 03/29/16 | DATE | 03/29/16 |
| DESIGNED BY | APPLE, INC. | SCALE | NONE |
| ENGINEERED BY | APPLE, INC. | SHEET | 1 OF 3 |
| DRAWING NUMBER | | TITLE | iPad Pro (9.7-inch) with Wi-Fi + Cellular |
| DATE | | BY | |
| | | CHECKED BY | |
| | | DATE | |
| THE INFORMATION CONTAINED HEREIN IS PROPRIETARY AND CONFIDENTIAL TO APPLE INC. AND IS TO BE USED ONLY FOR THE PURPOSES SPECIFIED. NO PART OF THIS DOCUMENT IS TO BE REPRODUCED OR TRANSMITTED IN ANY FORM OR BY ANY MEANS, ELECTRONIC OR MECHANICAL, WITHOUT PERMISSION FROM APPLE INC. | | © Apple Inc. All Rights Reserved. | |

40.77 iPad Pro (9.7-inch) Magnet/Hall Effect Sensors 1 of 2

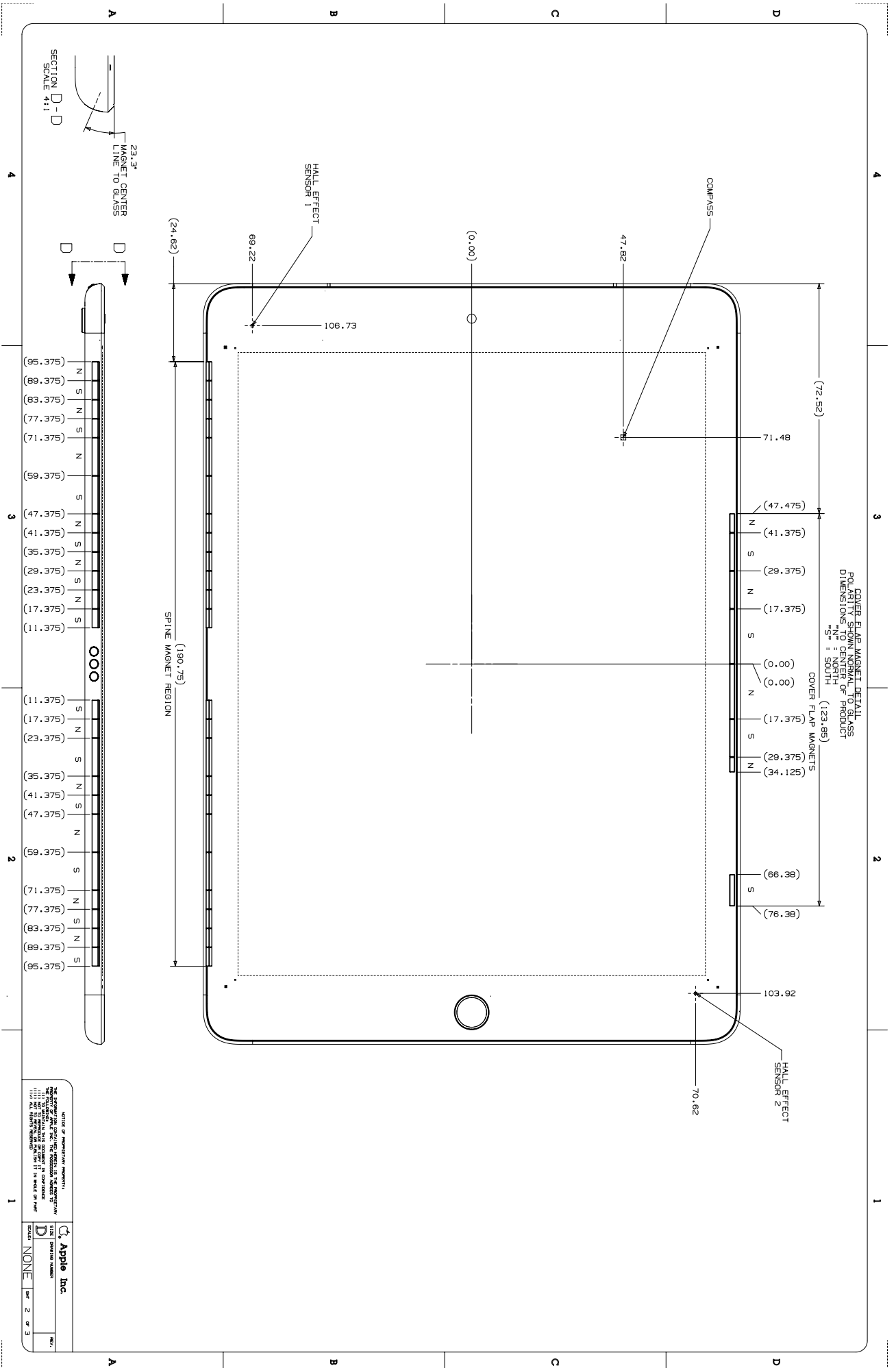

40.78 iPad Pro (9.7-inch) Magnet/Hall Effect Sensors 2 of 2

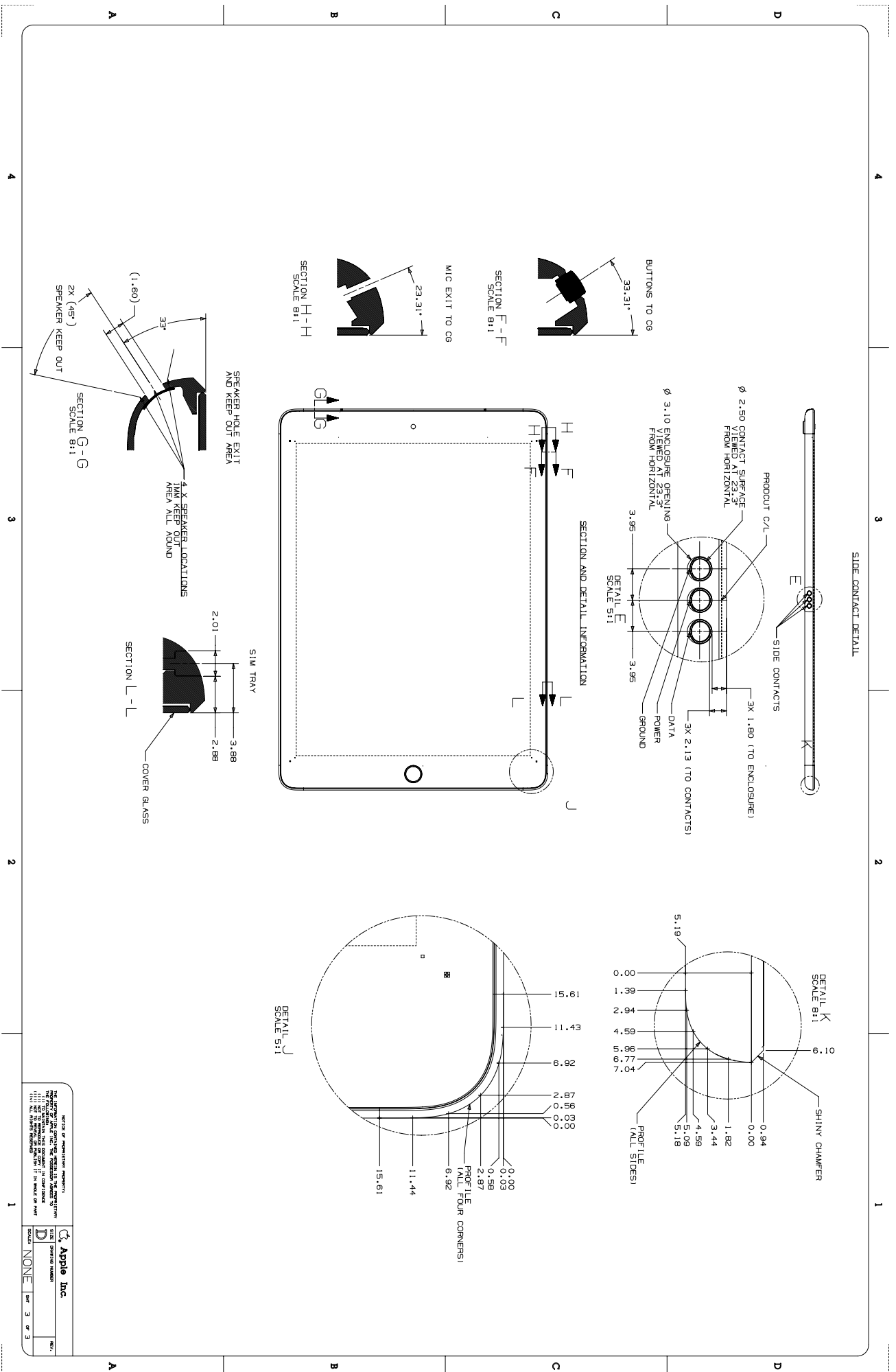

Apple Inc.
Copyright © 2020 Apple Inc. All Rights Reserved.

| | |
|-------|--------|
| Model | None |
| Part | 3 of 3 |

40.80 iPad Pro (12.9-inch) 1st Generation with Wi-Fi + Cellular

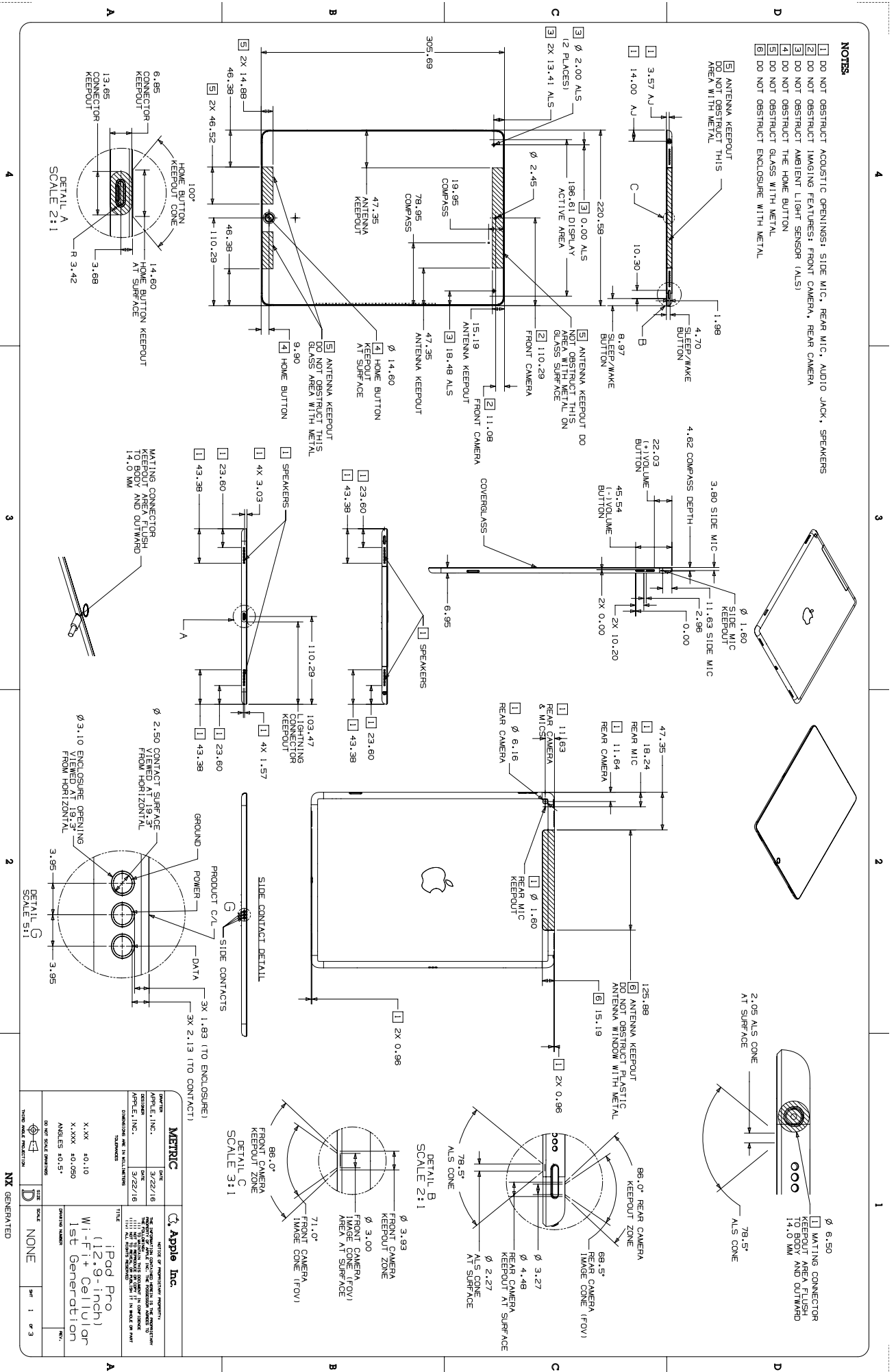

40.81 iPad Pro (12.9-inch) 1st Generation Magnet/Hall Effect Sensors 1 of 2

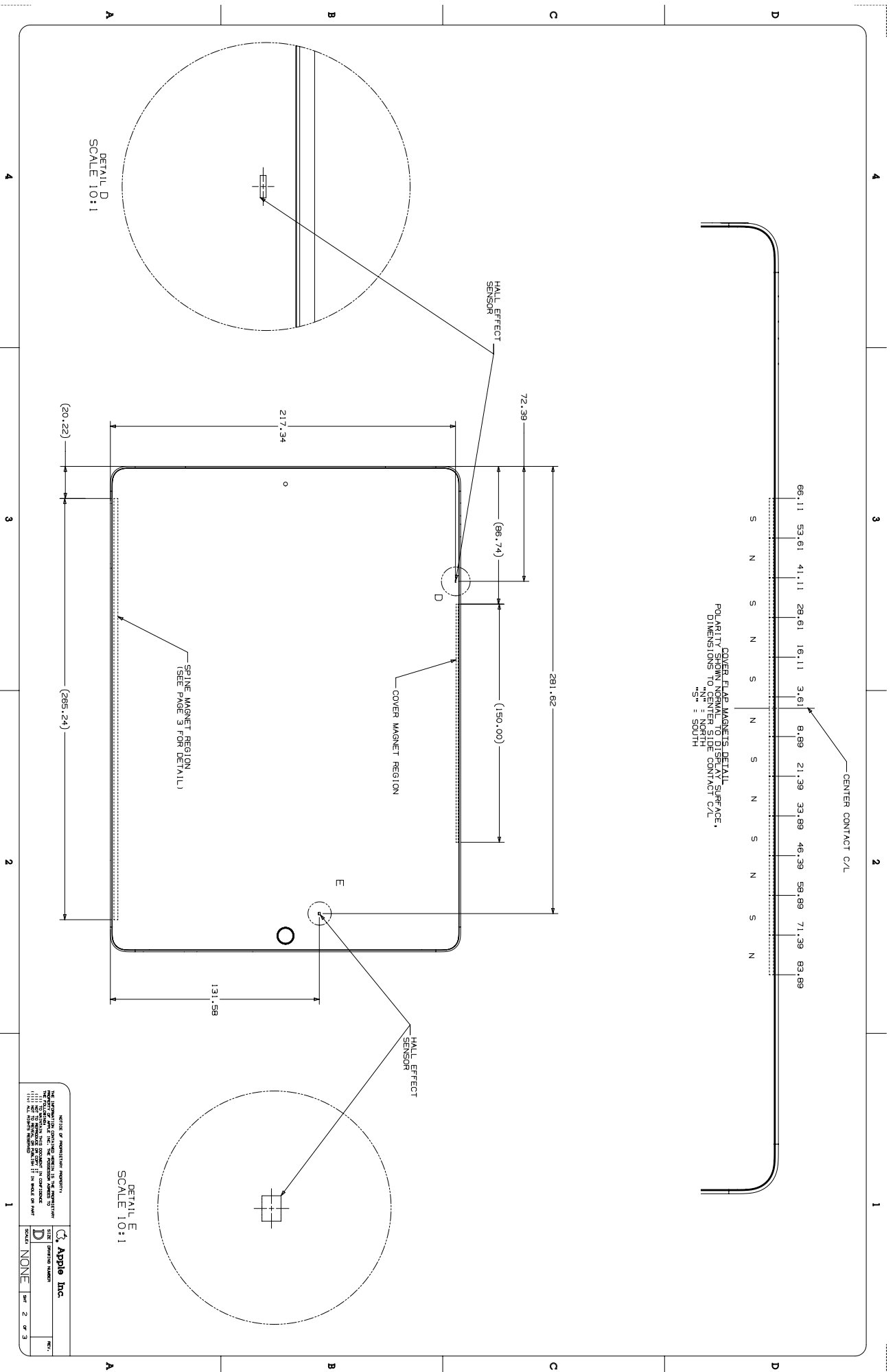

40.82 iPad Pro (12.9-inch) 1st Generation Magnet/Hall Effect Sensors 2 of 2

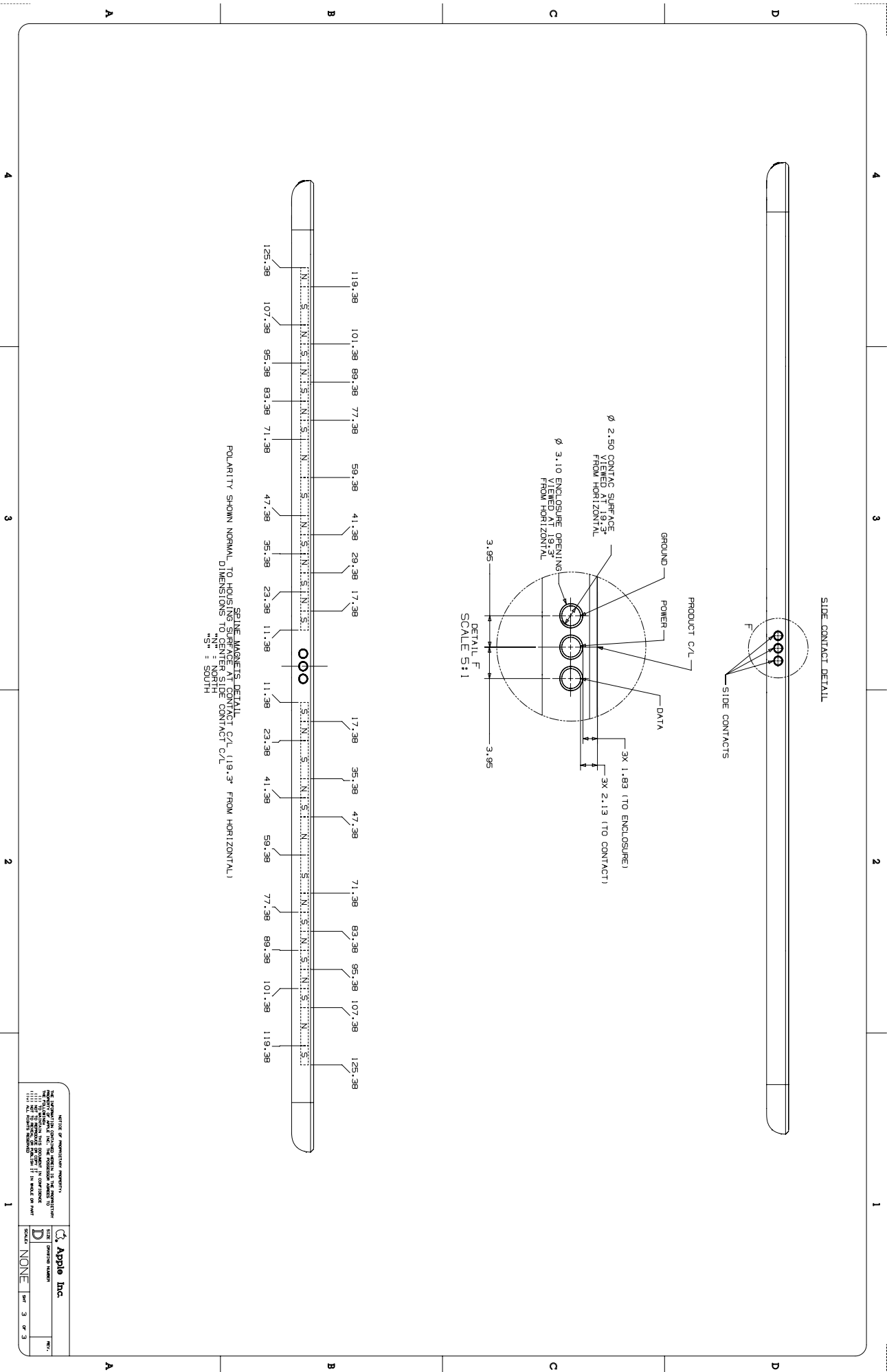

APPROVED FOR PRODUCTION ASSEMBLY
 THE INFORMATION CONTAINED HEREIN IS UNCLASSIFIED
 DATE 10/20/2011 BY 60322 UCBAW/PJM/ML/KSP/STP/STP
 11/11 10:21 AM (U.S. STANDARD TIME) IN COMPLIANCE
 WITH EXECUTIVE ORDER 13526, WHICH REQUIRES THAT
 ALL INFORMATION CONTAINED HEREIN BE CLASSIFIED "UNCLASSIFIED"
 UNLESS INDICATED OTHERWISE.

| | |
|------------|-----|
| Apple Inc. | REV |
| DATE | REV |
| 03/22/2011 | 1 |
| 04/01/2011 | 2 |
| 04/01/2011 | 3 |
| 04/01/2011 | 4 |

40.85 iPad mini 4 Magnet/Hall Effect Sensors

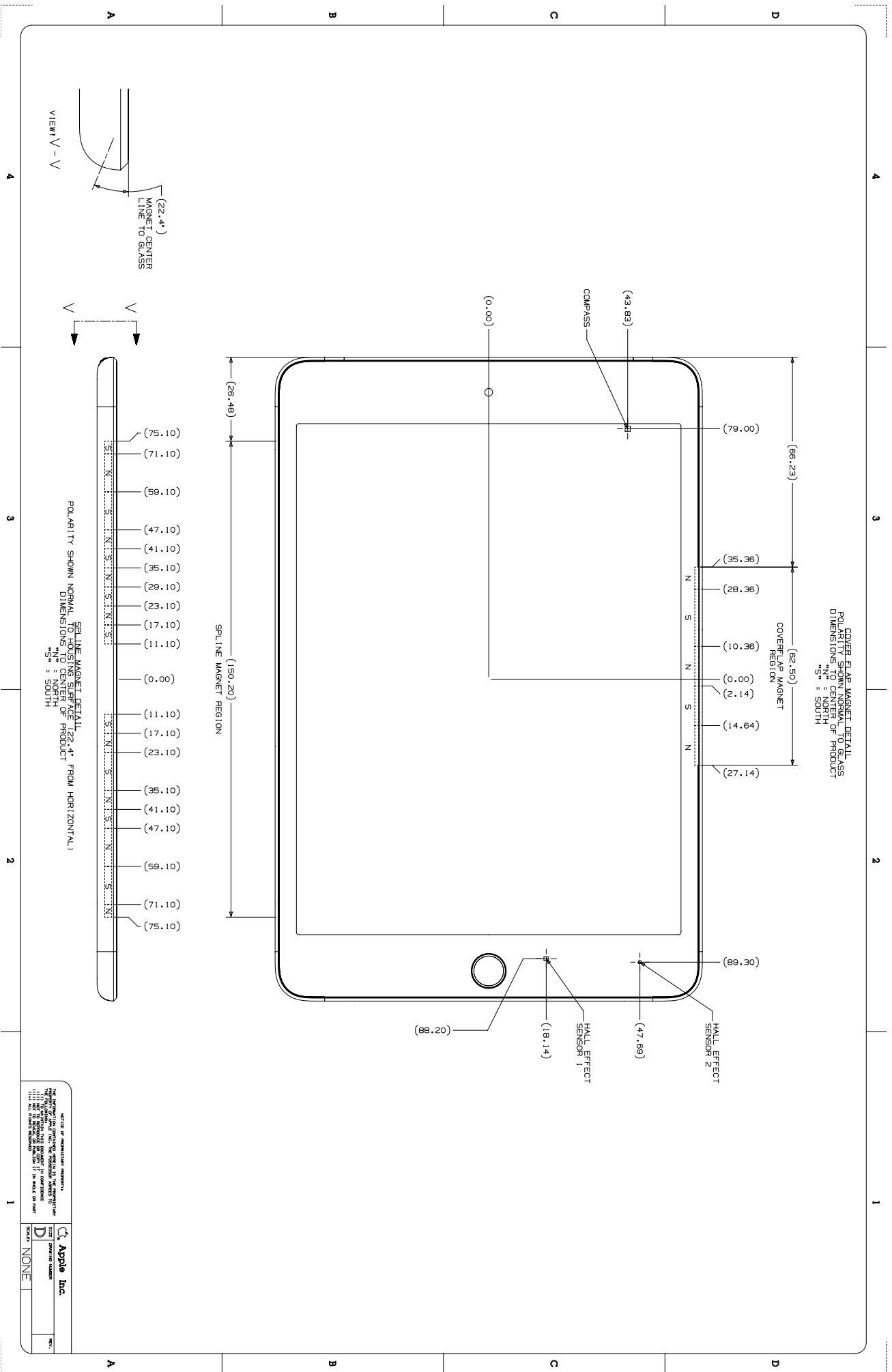

Apple Inc. **Apple Inc.**
 © 2014 Apple Inc. All rights reserved.
 The information contained herein is the property of Apple Inc. No portion of this document may be reproduced, stored in a retrieval system, or transmitted, in any form or by any means, without the prior written permission of Apple Inc. or its suppliers.

| | |
|-------------|--|
| Part | 40.85 iPad mini 4 Magnet/Hall Effect Sensors |
| Rev. | 1 |
| Drawn by | Apple Inc. |
| Checked by | Apple Inc. |
| Approved by | Apple Inc. |

Scale: NONE

40.86 iPad Air 2 with Wi-Fi

NOTES:

- 1 DO NOT OBSTRUCT ACOUSTIC OPENINGS, SIDE MIC, REAR MIC, AUDIO JACK, SPEAKERS
- 2 DO NOT OBSTRUCT IMAGING FEATURES: FRONT CAMERA, REAR CAMERA
- 3 DO NOT OBSTRUCT AMBIENT LIGHT SENSOR (ALS)
- 4 DO NOT OBSTRUCT THE HOME BUTTON
- 5 DO NOT OBSTRUCT GLASS WITH METAL
- 6 DO NOT OBSTRUCT ENCLOSURE WITH METAL

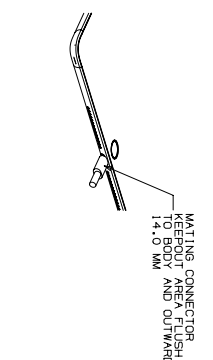
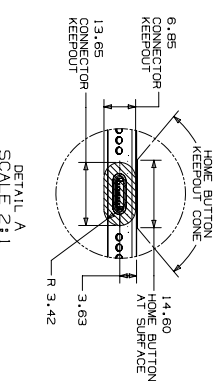
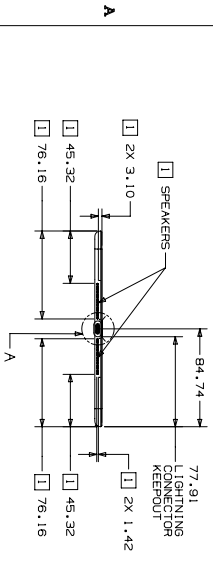
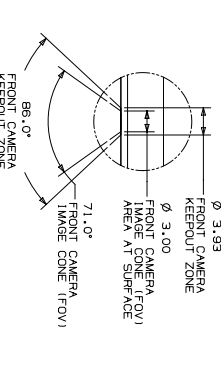
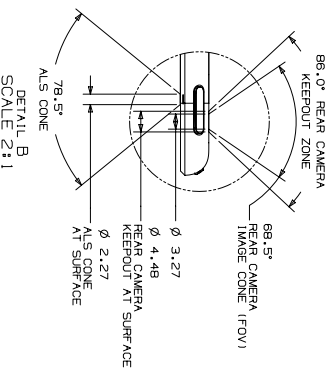
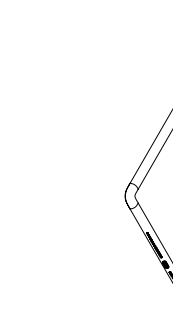
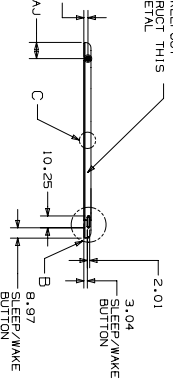
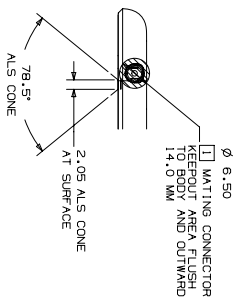
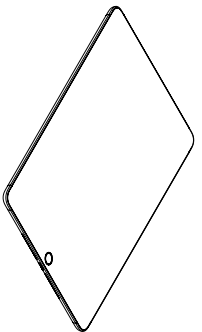
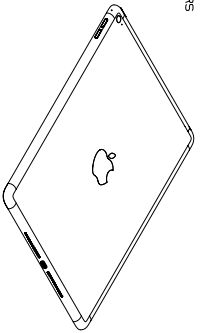

| | | | |
|--|--------------|------|--------|
| | | | |
| DATE | DATE | SIZE | SCALE |
| APPLIC. INC. | APPLIC. INC. | D | NONE |
| DESIGNER | DATE | SHR | 1 OF 1 |
| APPLIC. INC. | | | |
| CONSTRUCTION IN A MULTIVIEW DIMENSIONS ARE IN MILLIMETERS UNLESS OTHERWISE SPECIFIED | | | |
| TITLE iPod Air 2 Wi-Fi | | | |
| DRAWING NUMBER NONE | | | |
| 30 DAY SCALE EXPIRES THIS DRAWING IS VALID FOR 30 DAYS FROM THE DATE OF ISSUE THIS DRAWING IS VALID FOR 30 DAYS FROM THE DATE OF ISSUE THIS DRAWING IS VALID FOR 30 DAYS FROM THE DATE OF ISSUE THIS DRAWING IS VALID FOR 30 DAYS FROM THE DATE OF ISSUE | | | |
| NX GENERATED | | | |

40.87 iPad Air 2 with Wi-Fi + Cellular

NOTES:

- 1 DO NOT OBSTRUCT ACOUSTIC OPENINGS, SIDE MIC, REAR MIC, AUDIO JACK, SPEAKERS
- 2 DO NOT OBSTRUCT IMAGING FEATURES: FRONT CAMERA, REAR CAMERA
- 3 DO NOT OBSTRUCT AMBIENT LIGHT SENSOR (ALS)
- 4 DO NOT OBSTRUCT THE HOME BUTTON
- 5 DO NOT OBSTRUCT GLASS WITH METAL
- 6 DO NOT OBSTRUCT ENCLOSURE WITH METAL

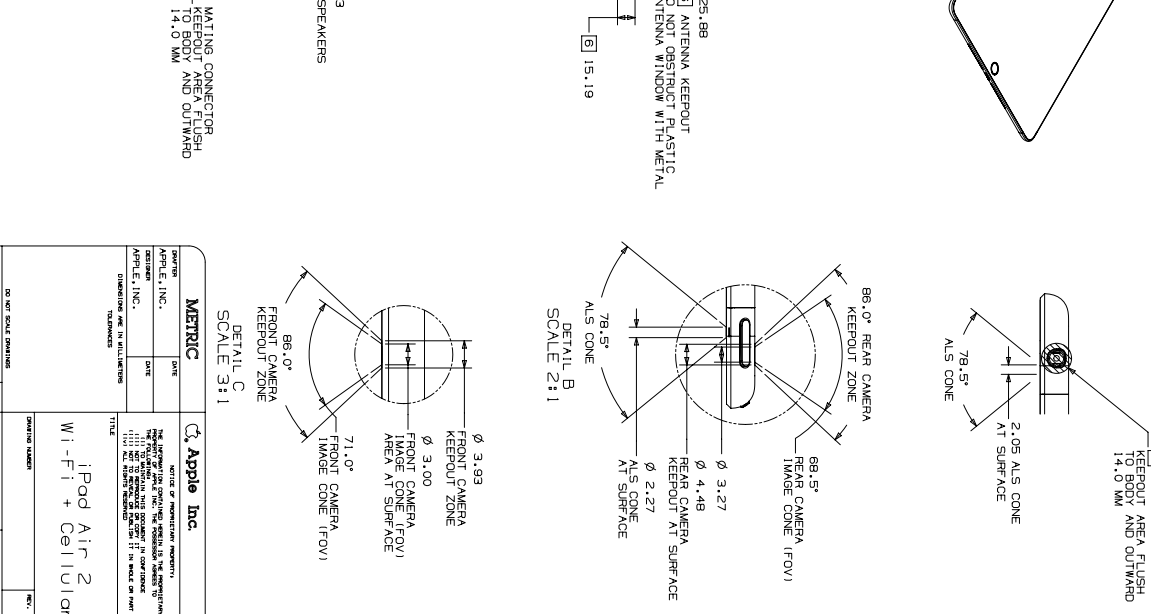
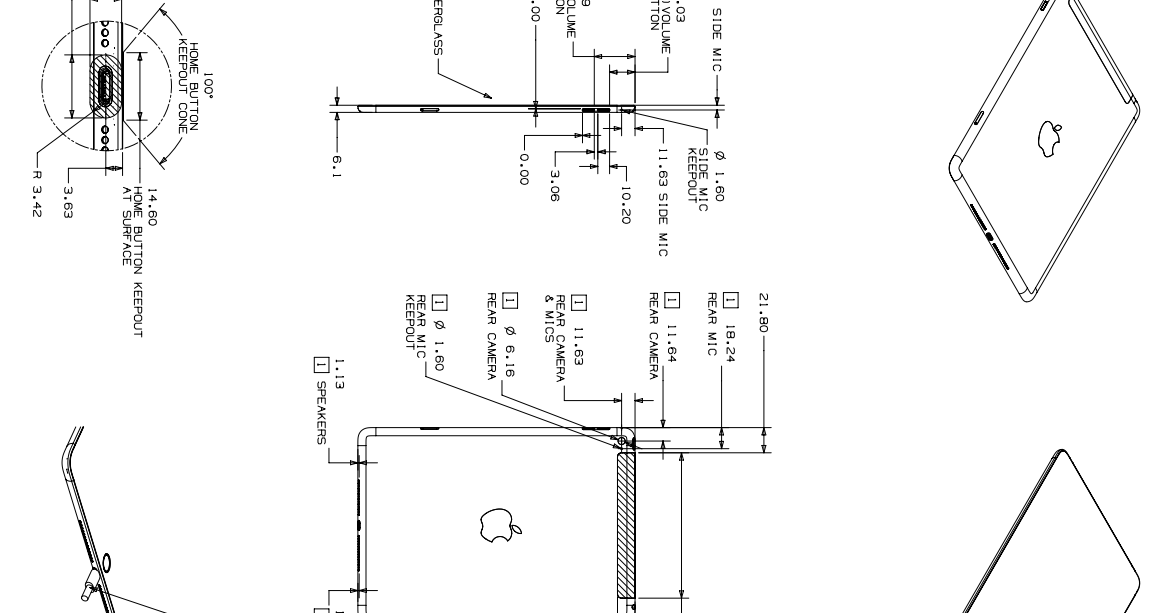
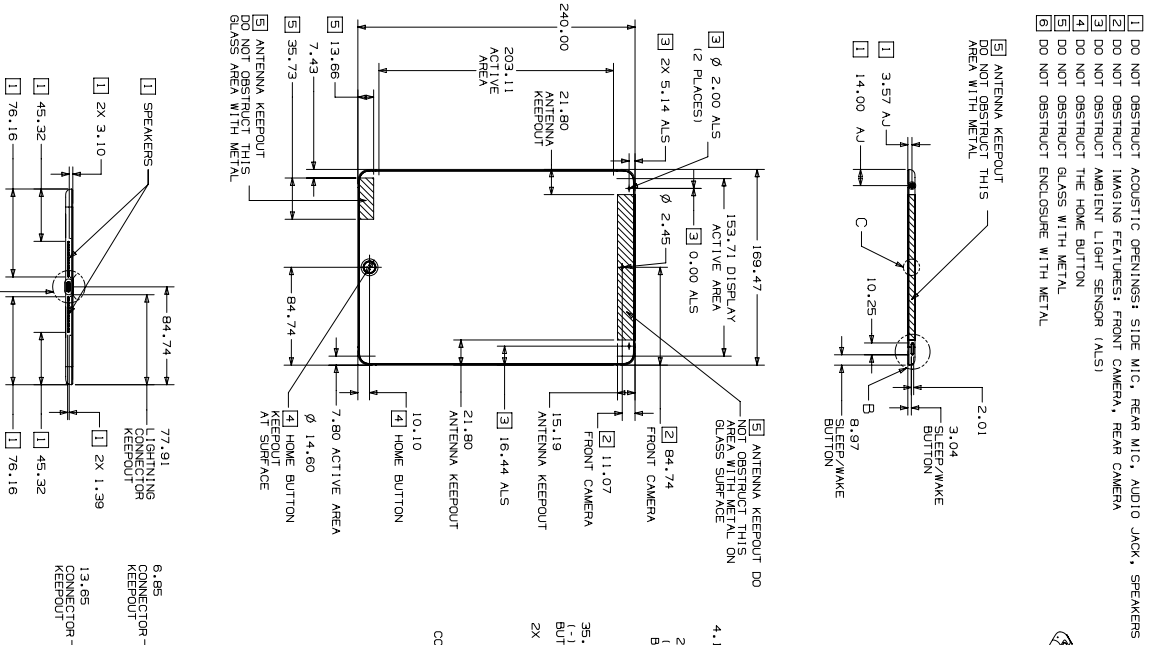
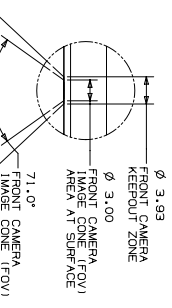
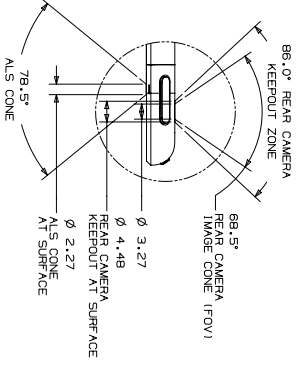
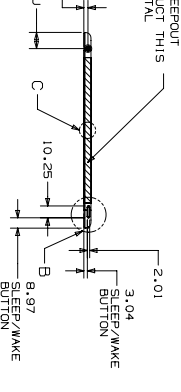
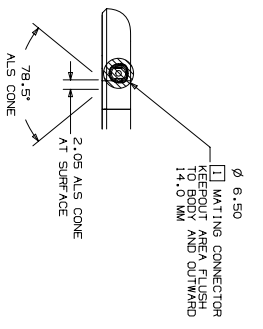
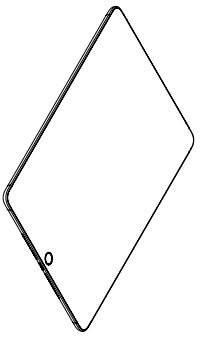
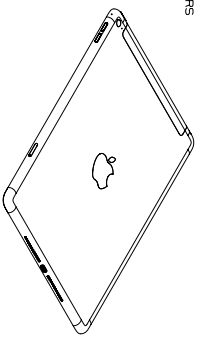

| | | | | | |
|------------|----------|------|-------|-----------|--------------|
| DATE | APPROVED | BY | SCALE | SHEET NO. | TOTAL SHEETS |
| 02/10/2016 | APPL | APPL | NONE | 1 | 1 |

Metric
 Apple Inc.
 Apple Inc.
 12800 Apple Blvd.
 Cupertino, CA 95014
 © 2015 Apple Inc. All rights reserved.

Title: **Wi-Fi + Cellular**
 Part Name: **Wi-Fi + Cellular**
 Drawing Number: **40.87**
 Scale: **1 of 1**

40.93 iPad mini with Wi-Fi + Cellular

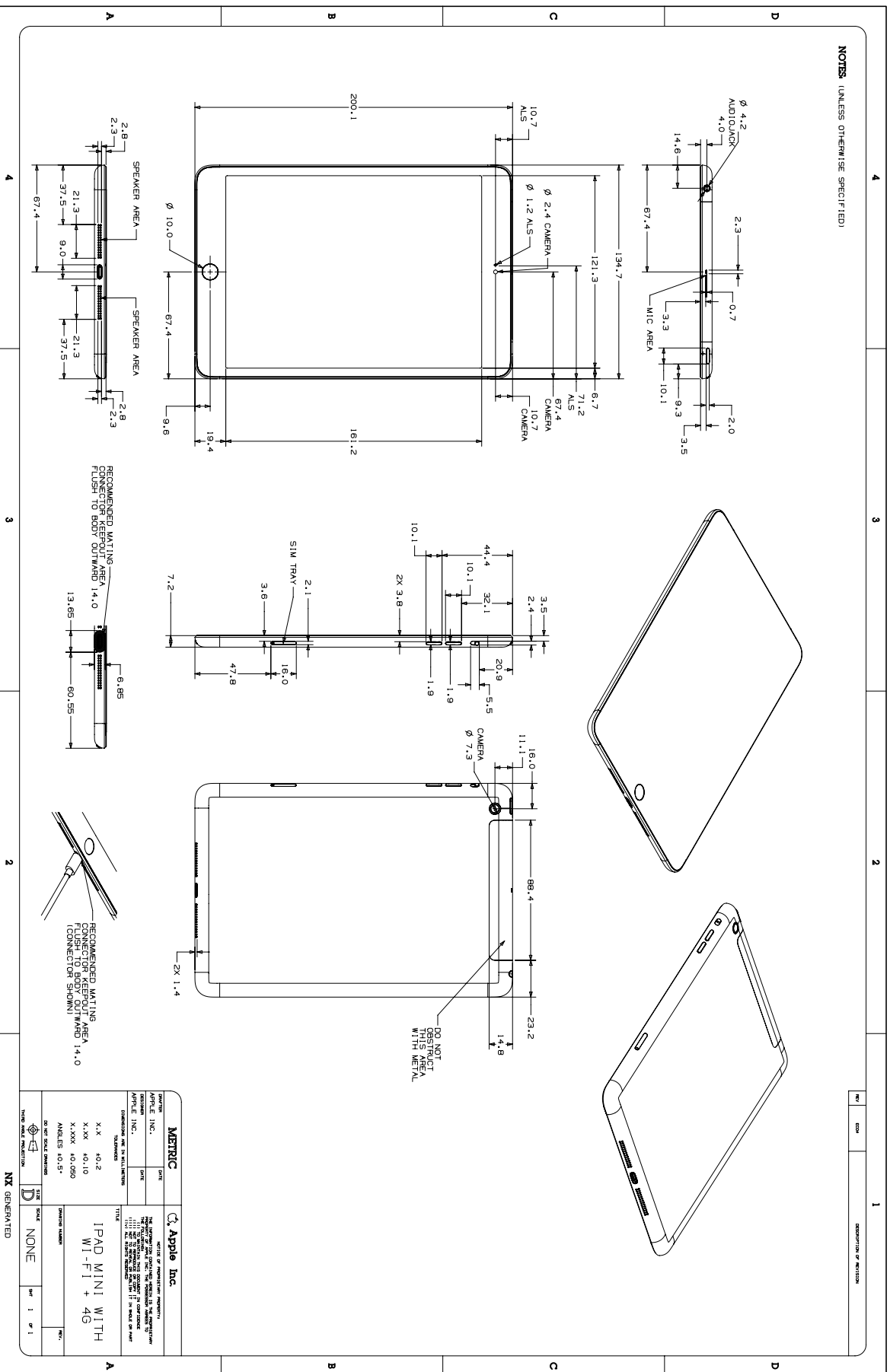

40.95 iPad (4th generation) with Wi-Fi + Cellular

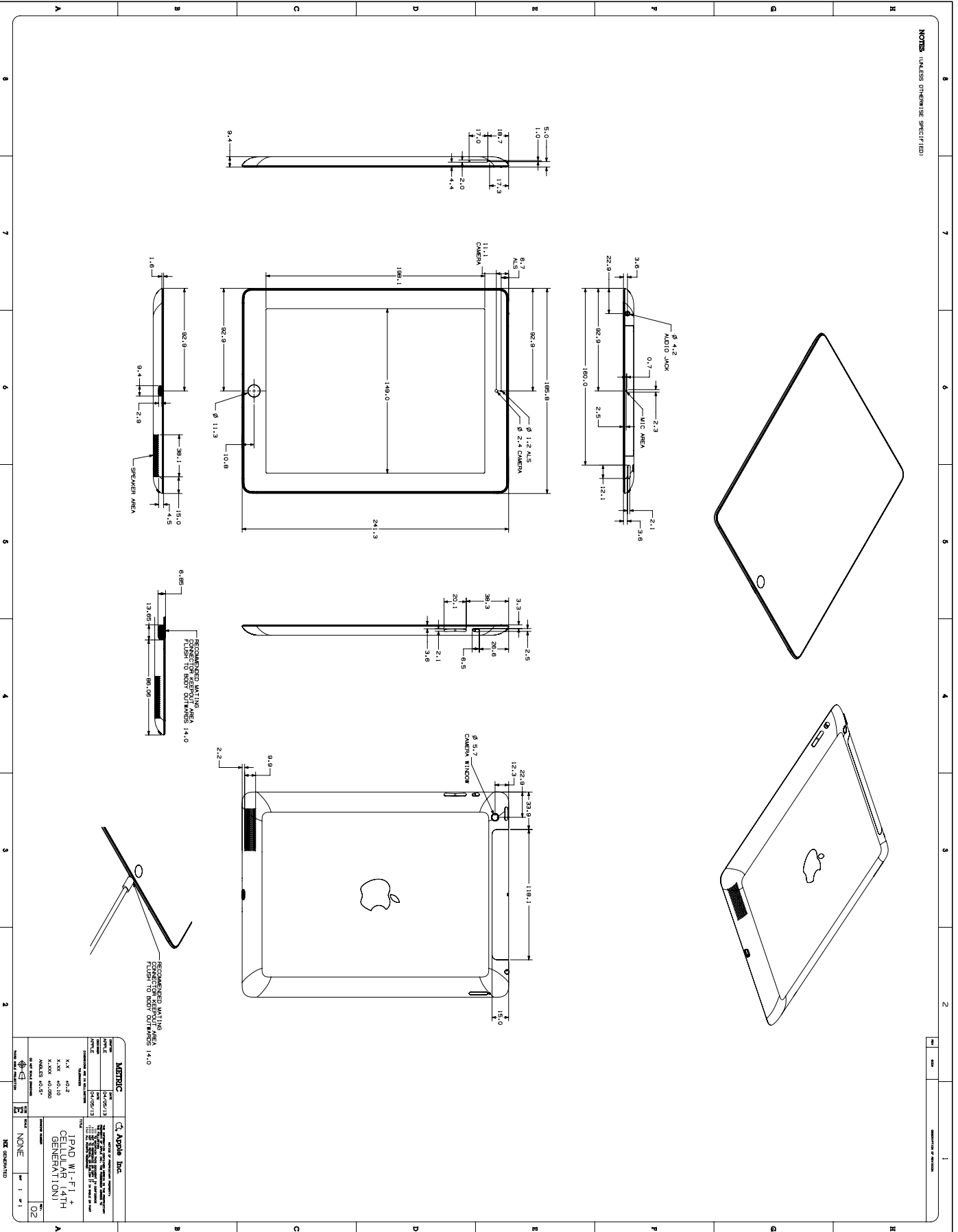

| | | | |
|---|------------|---|-------|
| Metric | | Apple Inc. | |
| DATE | REV | DESCRIPTION | BY |
| 2020/10/16 | 1 | 40.95 iPad (4th generation) with Wi-Fi + Cellular | |
| <p>THIS DRAWING IS THE PROPERTY OF APPLE INC. IT IS TO BE USED FOR THE DESIGN AND MANUFACTURE OF THE PRODUCT IDENTIFIED HEREIN. IT IS TO BE KEPT IN CONFIDENTIALITY AND NOT TO BE DISCLOSED TO ANY OTHER PARTY WITHOUT THE WRITTEN PERMISSION OF APPLE INC.</p> | | | |
| DESIGNED BY | DATE | TYPE | SCALE |
| K.K. 40.2 | 2020/10/16 | IPAD WI-FI + CELLULAR (4TH GENERATION) | 1:1 |
| DESIGNED BY | DATE | TYPE | SCALE |
| K.K. 40.2 | 2020/10/16 | IPAD WI-FI + CELLULAR (4TH GENERATION) | 1:1 |
| DESIGNED BY | DATE | TYPE | SCALE |
| K.K. 40.2 | 2020/10/16 | IPAD WI-FI + CELLULAR (4TH GENERATION) | 1:1 |
| DESIGNED BY | DATE | TYPE | SCALE |
| K.K. 40.2 | 2020/10/16 | IPAD WI-FI + CELLULAR (4TH GENERATION) | 1:1 |

40.96 iPod touch (6th generation) & iPod touch (7th generation)

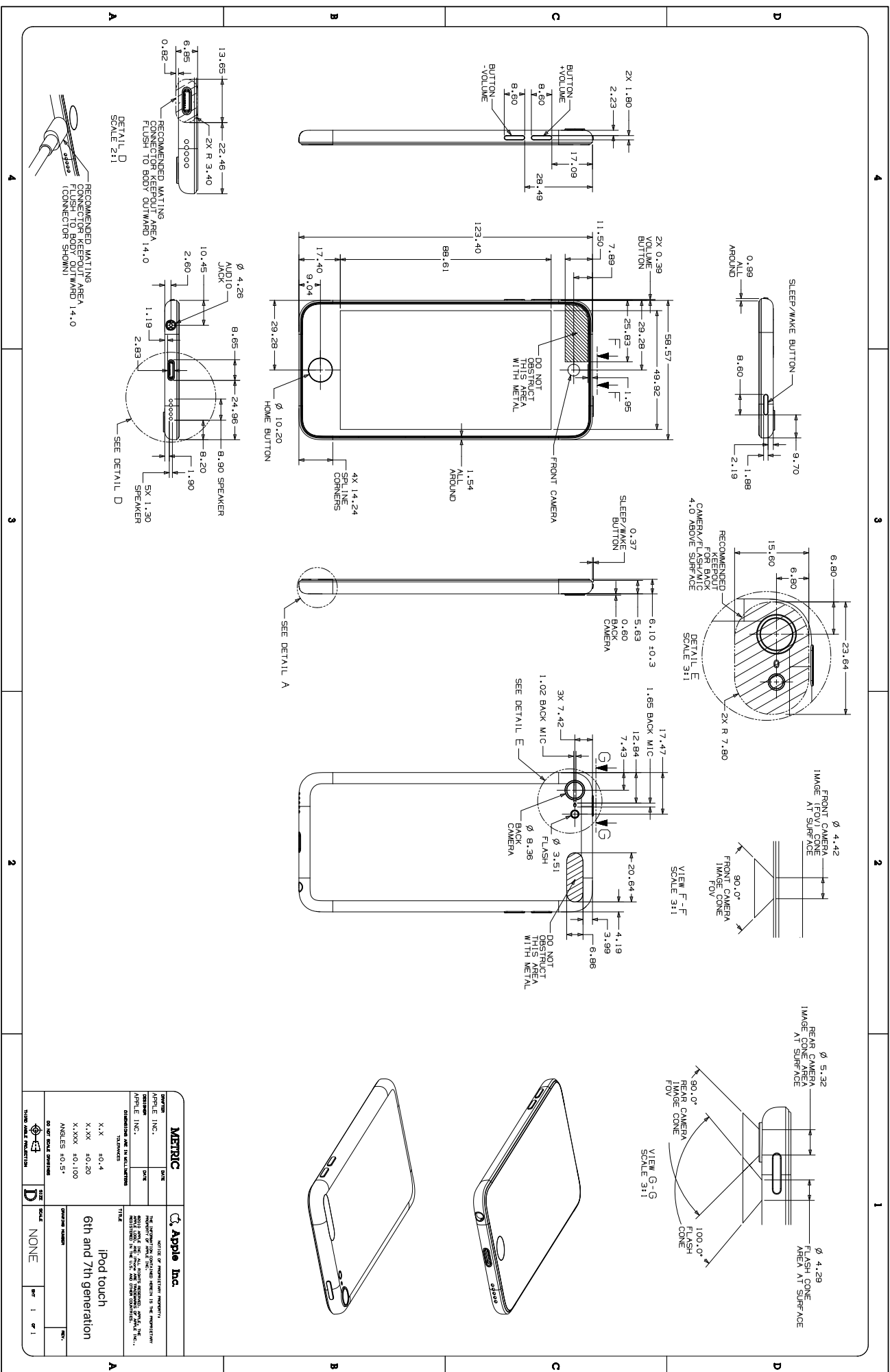

40.98 Apple Watch Series 6, 44 mm

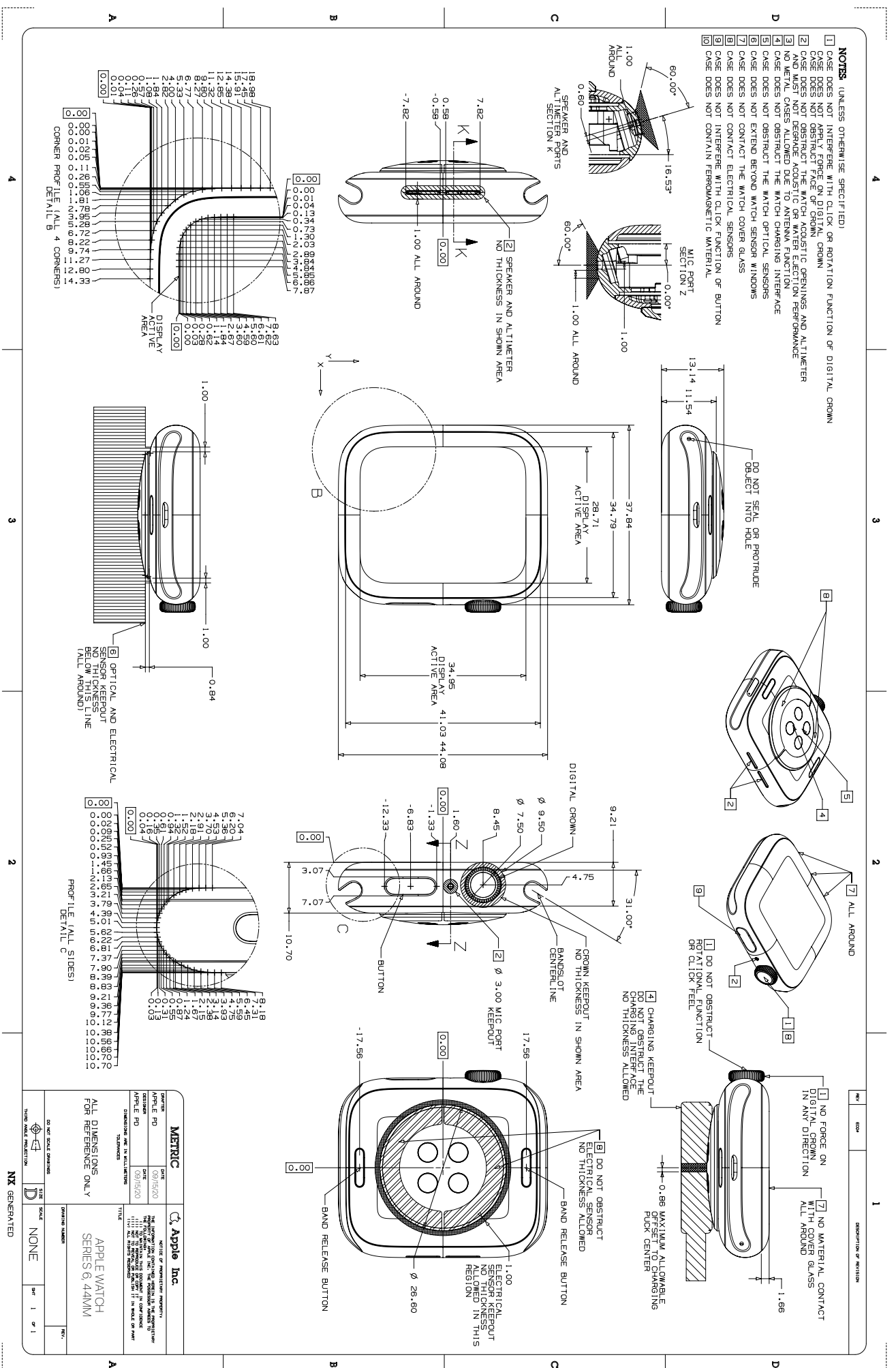

40.99 Apple Watch Series 6, 40 mm

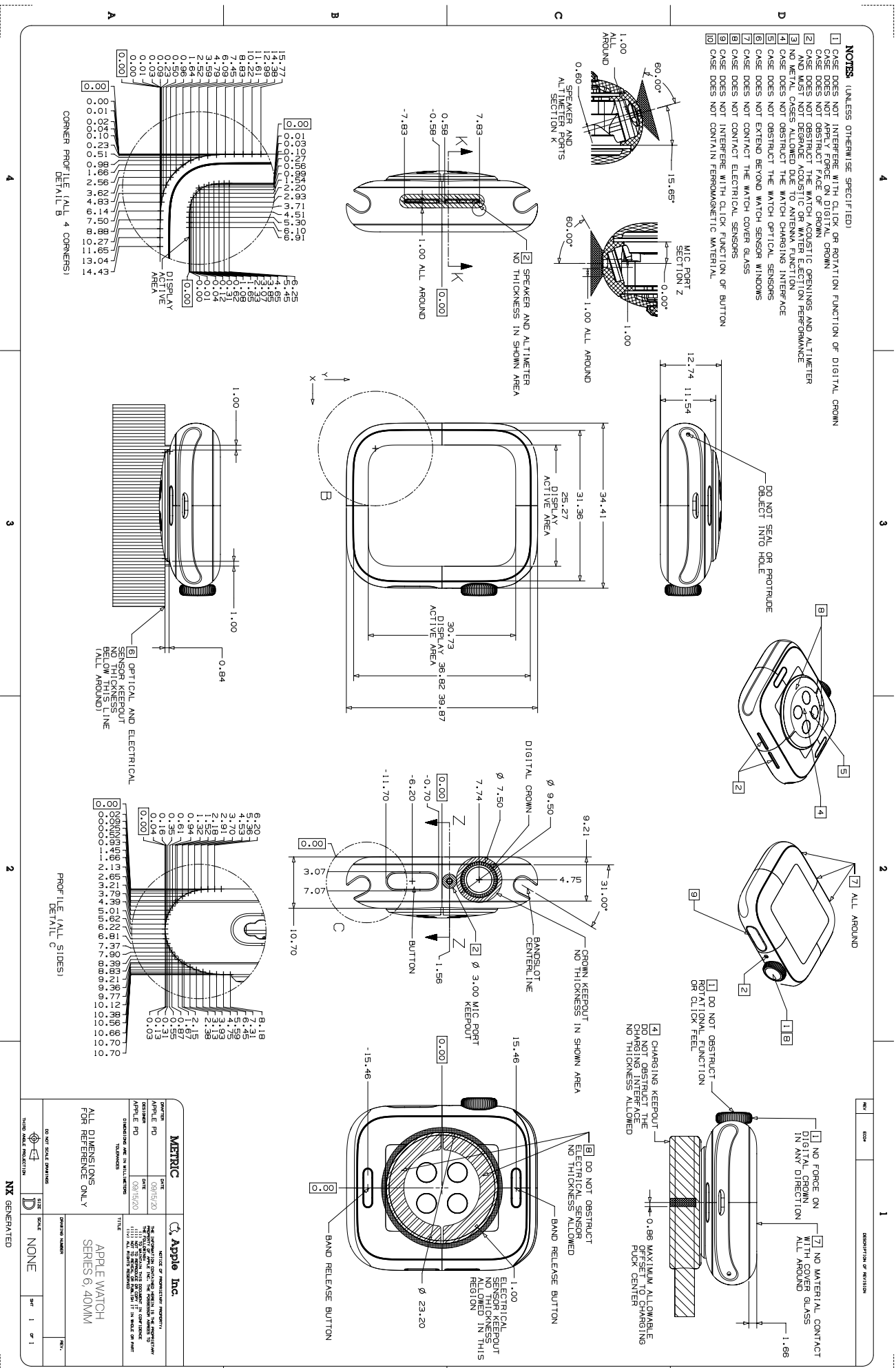

40.101 Apple Watch SE, 40 mm

- NOTES:** (UNLESS OTHERWISE SPECIFIED)
- 1 CASE DOES NOT INTERFERE WITH CLICK OR ROTATION FUNCTION OF DIGITAL CROWN
 - 2 CASE DOES NOT APPLY FORCE ON DIGITAL CROWN
 - 3 CASE DOES NOT OBSTRUCT FACE OF CROWN
 - 4 CASE DOES NOT OBSTRUCT WATCH ACOUSTIC OPENINGS AND ALTIMETER
 - 5 CASE DOES NOT OBSTRUCT WATCH CHARGING PORT
 - 6 NO METAL CASES ALLOWED DUE TO ANTENNA FUNCTION
 - 7 CASE DOES NOT OBSTRUCT THE WATCH CHANGING INTERFACE
 - 8 CASE DOES NOT OBSTRUCT THE WATCH OPTICAL WINDOWS
 - 9 CASE DOES NOT EXTEND BEYOND WATCH SENSOR WINDOWS
 - 10 CASE DOES NOT CONTACT THE WATCH COVER GLASS
 - 11 CASE DOES NOT CONTAIN FERROMAGNETIC MATERIAL

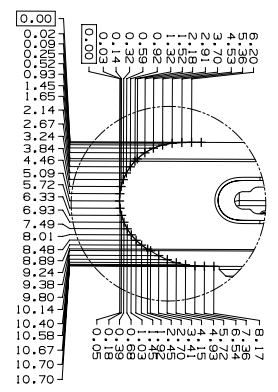
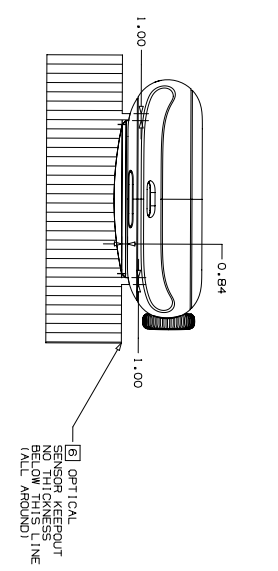
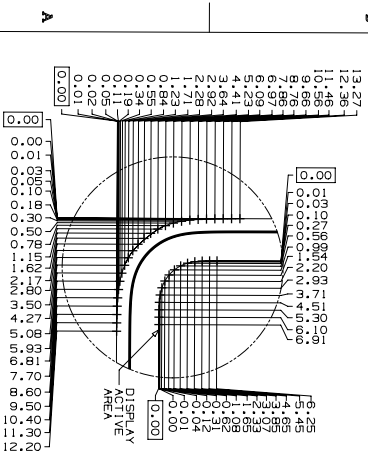
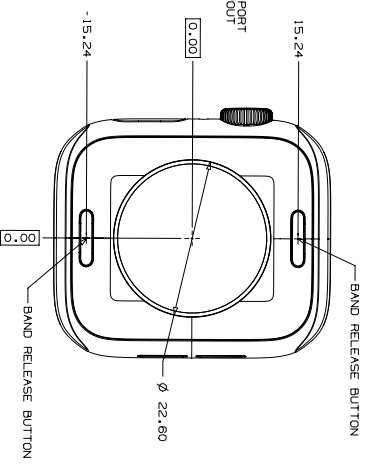
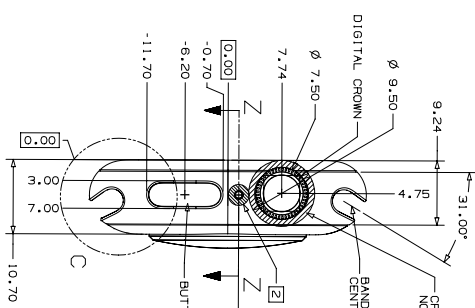
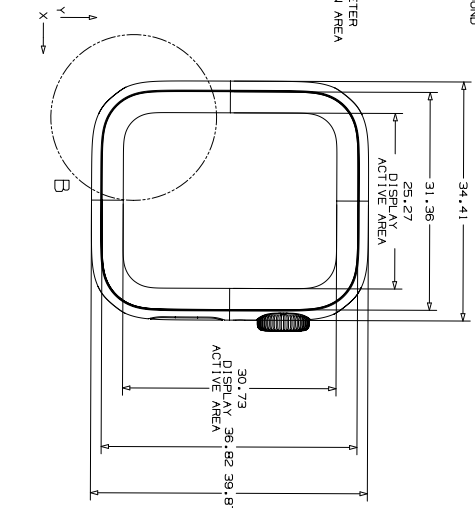
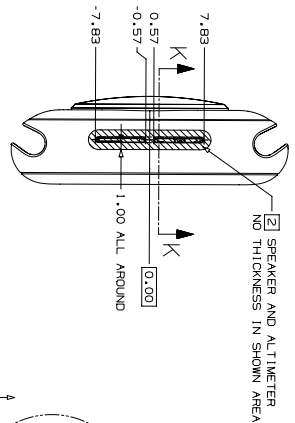
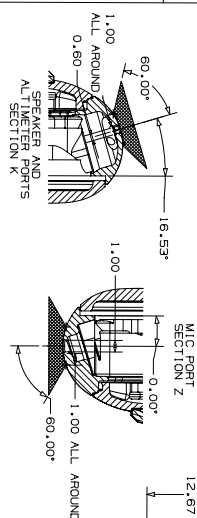
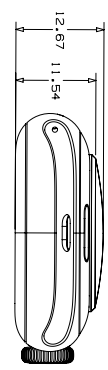
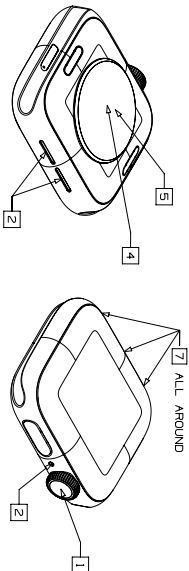

| PART INFORMATION | | DRAWING NUMBER | |
|------------------|---|----------------|------|
| NO. | DESC. | REV. | DATE |
| 01 | INITIAL RELEASE | | |
| 02 | FC SHIFTED 20MM INTO SYSTEM MATTER DRAWN 08/27/20 | | |

| MATERIALS | | TITLE | |
|-----------|-------------|----------|------|
| PROVIDER | DESCRIPTION | DATE | REV. |
| APPLE IPD | APPLE IPD | 09/15/20 | |
| APPLE IPD | APPLE IPD | 09/15/20 | |

| DRAWING INFORMATION | | DRAWING NUMBER | |
|---------------------|-------------|----------------|----------|
| SCALE | UNIT | REV. | DATE |
| NONE | MILLIMETERS | 1 | 09/15/20 |

Apple Inc.
 3655 Market Street, Suite 5000, San Francisco, CA 94143
 © 2020 Apple Inc. All rights reserved.
 Apple, the Apple logo, and Watch are trademarks of Apple Inc., registered in the U.S. and other countries.
 iPhone is a trademark of Apple Inc., registered in the U.S. and other countries.
 All other marks contained herein are the property of their respective owners.

NX GENERATED

40.102 Apple Watch Series 5, 44 mm

- NOTES:** (UNLESS OTHERWISE SPECIFIED)
- CASE DOES NOT INTERFERE WITH CLICK OR ROTATION FUNCTION OF DIGITAL CROWN
 - CASE DOES NOT APPLY FORCE ON DIGITAL CROWN
 - CASE DOES NOT OBSTRUCT FACE OF CROWN
 - CASE DOES NOT OBSTRUCT WATCH ADJUSTIC OPENINGS AND ALTIMETER
 - CASE DOES NOT OBSTRUCT MICROPHONE PERFORMANCE
 - NO METAL CASES ALLOWED DUE TO ANTENNA FUNCTION
 - CASE DOES NOT OBSTRUCT THE WATCH CHARGING INTERFACE
 - CASE DOES NOT OBSTRUCT THE WATCH OPTICAL SENSORS
 - CASE DOES NOT EXTEND BEYOND SENSOR WINDOWS
 - CASE DOES NOT CONTACT THE WATCH COVER GLASS
 - CASE DOES NOT CONTACT ELECTRICAL SENSORS
 - CASE DOES NOT CONTAIN FERROMAGNETIC MATERIAL

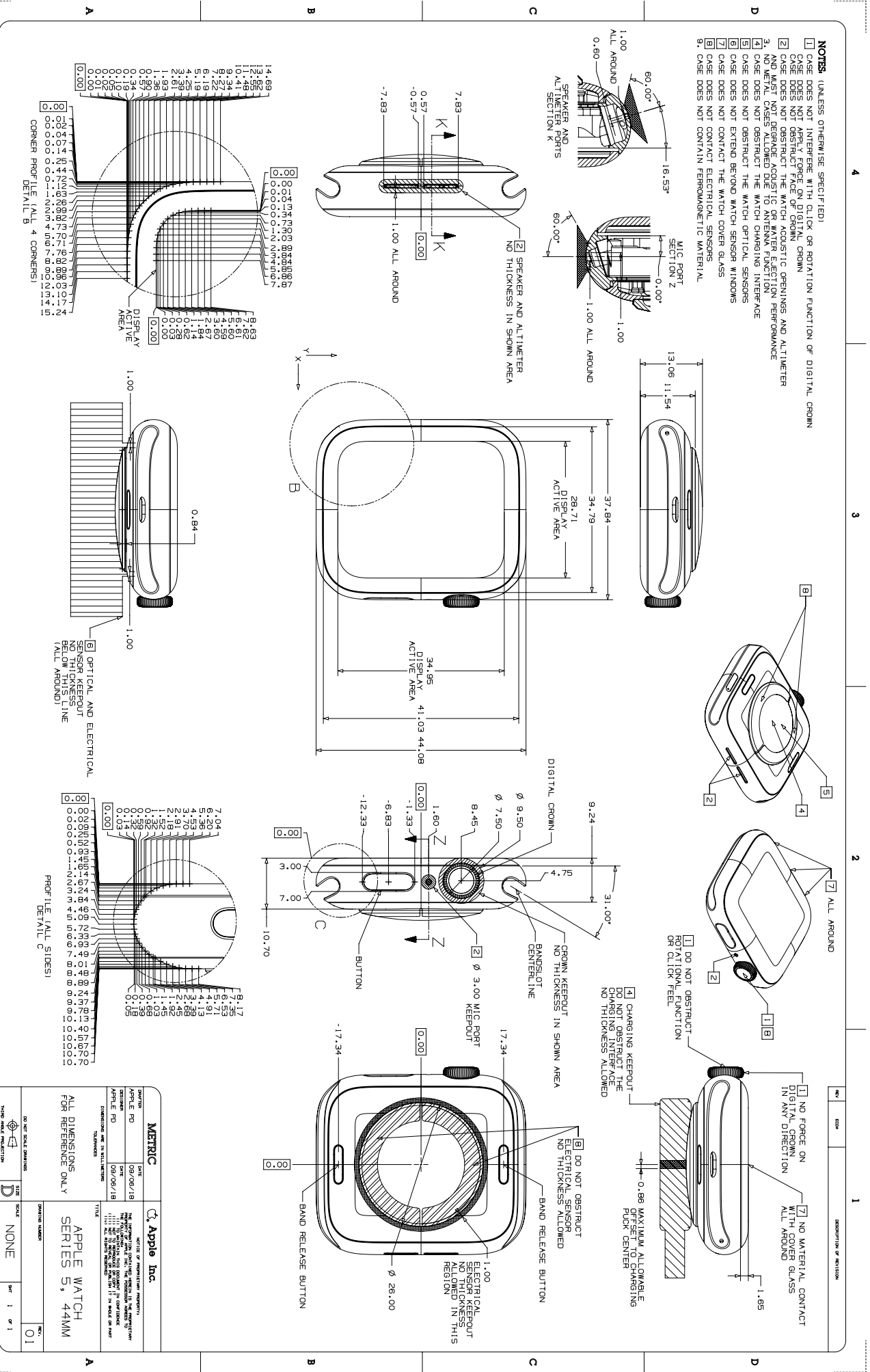

| METRIC | | DATE | | REVISION | |
|--|----------|------|----------|----------|---|
| APPLICABLE PD | 09/08/18 | DATE | 09/08/18 | REVISION | 1 |
| APPLICABLE PD | 09/08/18 | DATE | 09/08/18 | REVISION | 1 |
| APPLICABLE PD | 09/08/18 | DATE | 09/08/18 | REVISION | 1 |
| <p>ALL DIMENSIONS FOR REFERENCE ONLY</p> <p>APPLE WATCH SERIES 5, 44MM</p> <p>DATE: 09/08/18</p> <p>TIME: 11:11:11</p> <p>USER: [NAME]</p> <p>TITLE: [TITLE]</p> <p>SCALE: NONE</p> <p>SHEET: 1 of 1</p> | | | | | |

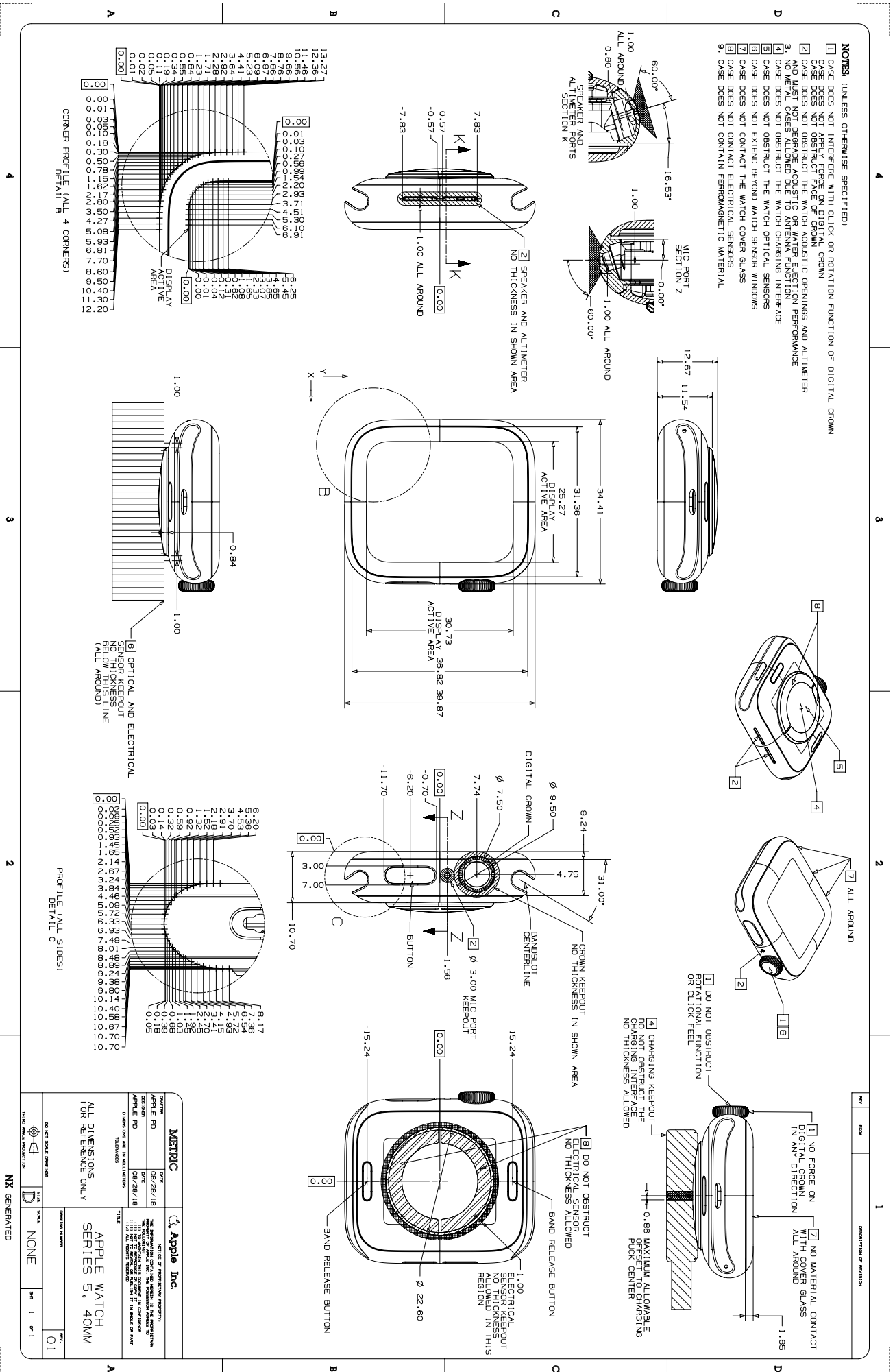

- NOTES (UNLESS OTHERWISE SPECIFIED):**
- 1 CASE DOES NOT INTERFERE WITH CLICK OR THICKNESS FUNCTION OF DIGITAL CROWN
 - 2 CASE DOES NOT APPLY FORCE ON DIGITAL CROWN
 - 3 CASE DOES NOT OBSTRUCT FACE OF CROWN
 - 4 CASE DOES NOT OBSTRUCT THE WATCH ACOUSTIC OPENINGS AND ALTIMETER AND MUST NOT INTERFERE WITH WATCH ACOUSTIC AND ALTIMETER PERFORMANCE
 - 5 CASE DOES NOT OBSTRUCT DIGITAL CROWN TOUCH INTERFACE
 - 6 CASE DOES NOT OBSTRUCT THE WATCH CHARGING INTERFACE
 - 7 CASE DOES NOT OBSTRUCT THE WATCH OPTICAL SENSORS
 - 8 CASE DOES NOT CONTACT THE WATCH SENSOR WINDOWS
 - 9 CASE DOES NOT CONTACT ELECTRICAL SENSORS
 - 10 CASE DOES NOT CONTACT PERFORMERS 110 MATERIAL

PROFILES (ALL SIDES)

| | | | | |
|-------|------|-------|------|------|
| 13.42 | 6.45 | 11.15 | 1.48 | 1.19 |
| 11.48 | 4.95 | 9.18 | 1.19 | 1.12 |
| 10.56 | 4.41 | 7.70 | 1.19 | 1.07 |
| 9.68 | 3.84 | 6.22 | 1.19 | 1.02 |
| 8.82 | 3.26 | 4.74 | 1.19 | 0.97 |
| 7.98 | 2.67 | 3.26 | 1.19 | 0.92 |
| 7.18 | 2.08 | 1.78 | 1.19 | 0.87 |
| 6.39 | 1.48 | 0.30 | 1.19 | 0.82 |
| 5.64 | 0.89 | | 1.19 | 0.77 |
| 4.91 | 0.30 | | 1.19 | 0.72 |
| 4.21 | | | 1.19 | 0.67 |
| 3.54 | | | 1.19 | 0.62 |
| 2.92 | | | 1.19 | 0.57 |
| 2.32 | | | 1.19 | 0.52 |
| 1.72 | | | 1.19 | 0.47 |
| 1.14 | | | 1.19 | 0.42 |
| 0.58 | | | 1.19 | 0.37 |
| 0.04 | | | 1.19 | 0.32 |
| 0.19 | | | 1.19 | 0.27 |
| 0.34 | | | 1.19 | 0.22 |
| 0.48 | | | 1.19 | 0.17 |
| 0.61 | | | 1.19 | 0.12 |
| 0.74 | | | 1.19 | 0.07 |
| 0.86 | | | 1.19 | 0.02 |
| 0.98 | | | 1.19 | 0.00 |
| 1.10 | | | 1.19 | 0.00 |
| 1.22 | | | 1.19 | 0.00 |

PROFILES (ALL SIDES)

| | | | | |
|-------|-------|------|------|------|
| 8.17 | 15.24 | 2.29 | 0.79 | 0.51 |
| 7.36 | 13.76 | 1.83 | 0.79 | 0.51 |
| 6.54 | 12.28 | 1.37 | 0.79 | 0.51 |
| 5.73 | 10.80 | 0.91 | 0.79 | 0.51 |
| 4.91 | 9.32 | 0.45 | 0.79 | 0.51 |
| 4.10 | 7.84 | | 0.79 | 0.51 |
| 3.28 | 6.36 | | 0.79 | 0.51 |
| 2.47 | 4.88 | | 0.79 | 0.51 |
| 1.65 | 3.40 | | 0.79 | 0.51 |
| 0.84 | 1.92 | | 0.79 | 0.51 |
| 0.03 | 0.44 | | 0.79 | 0.51 |
| 0.18 | | | 0.79 | 0.51 |
| 0.33 | | | 0.79 | 0.51 |
| 0.48 | | | 0.79 | 0.51 |
| 0.63 | | | 0.79 | 0.51 |
| 0.78 | | | 0.79 | 0.51 |
| 0.93 | | | 0.79 | 0.51 |
| 1.08 | | | 0.79 | 0.51 |
| 1.23 | | | 0.79 | 0.51 |
| 1.38 | | | 0.79 | 0.51 |
| 1.53 | | | 0.79 | 0.51 |
| 1.68 | | | 0.79 | 0.51 |
| 1.83 | | | 0.79 | 0.51 |
| 1.98 | | | 0.79 | 0.51 |
| 2.13 | | | 0.79 | 0.51 |
| 2.28 | | | 0.79 | 0.51 |
| 2.43 | | | 0.79 | 0.51 |
| 2.58 | | | 0.79 | 0.51 |
| 2.73 | | | 0.79 | 0.51 |
| 2.88 | | | 0.79 | 0.51 |
| 3.03 | | | 0.79 | 0.51 |
| 3.18 | | | 0.79 | 0.51 |
| 3.33 | | | 0.79 | 0.51 |
| 3.48 | | | 0.79 | 0.51 |
| 3.63 | | | 0.79 | 0.51 |
| 3.78 | | | 0.79 | 0.51 |
| 3.93 | | | 0.79 | 0.51 |
| 4.08 | | | 0.79 | 0.51 |
| 4.23 | | | 0.79 | 0.51 |
| 4.38 | | | 0.79 | 0.51 |
| 4.53 | | | 0.79 | 0.51 |
| 4.68 | | | 0.79 | 0.51 |
| 4.83 | | | 0.79 | 0.51 |
| 4.98 | | | 0.79 | 0.51 |
| 5.13 | | | 0.79 | 0.51 |
| 5.28 | | | 0.79 | 0.51 |
| 5.43 | | | 0.79 | 0.51 |
| 5.58 | | | 0.79 | 0.51 |
| 5.73 | | | 0.79 | 0.51 |
| 5.88 | | | 0.79 | 0.51 |
| 6.03 | | | 0.79 | 0.51 |
| 6.18 | | | 0.79 | 0.51 |
| 6.33 | | | 0.79 | 0.51 |
| 6.48 | | | 0.79 | 0.51 |
| 6.63 | | | 0.79 | 0.51 |
| 6.78 | | | 0.79 | 0.51 |
| 6.93 | | | 0.79 | 0.51 |
| 7.08 | | | 0.79 | 0.51 |
| 7.23 | | | 0.79 | 0.51 |
| 7.38 | | | 0.79 | 0.51 |
| 7.53 | | | 0.79 | 0.51 |
| 7.68 | | | 0.79 | 0.51 |
| 7.83 | | | 0.79 | 0.51 |
| 7.98 | | | 0.79 | 0.51 |
| 8.13 | | | 0.79 | 0.51 |
| 8.28 | | | 0.79 | 0.51 |
| 8.43 | | | 0.79 | 0.51 |
| 8.58 | | | 0.79 | 0.51 |
| 8.73 | | | 0.79 | 0.51 |
| 8.88 | | | 0.79 | 0.51 |
| 9.03 | | | 0.79 | 0.51 |
| 9.18 | | | 0.79 | 0.51 |
| 9.33 | | | 0.79 | 0.51 |
| 9.48 | | | 0.79 | 0.51 |
| 9.63 | | | 0.79 | 0.51 |
| 9.78 | | | 0.79 | 0.51 |
| 9.93 | | | 0.79 | 0.51 |
| 10.08 | | | 0.79 | 0.51 |
| 10.23 | | | 0.79 | 0.51 |
| 10.38 | | | 0.79 | 0.51 |
| 10.53 | | | 0.79 | 0.51 |
| 10.68 | | | 0.79 | 0.51 |
| 10.83 | | | 0.79 | 0.51 |
| 10.98 | | | 0.79 | 0.51 |
| 11.13 | | | 0.79 | 0.51 |
| 11.28 | | | 0.79 | 0.51 |
| 11.43 | | | 0.79 | 0.51 |
| 11.58 | | | 0.79 | 0.51 |
| 11.73 | | | 0.79 | 0.51 |
| 11.88 | | | 0.79 | 0.51 |
| 12.03 | | | 0.79 | 0.51 |
| 12.18 | | | 0.79 | 0.51 |
| 12.33 | | | 0.79 | 0.51 |
| 12.48 | | | 0.79 | 0.51 |
| 12.63 | | | 0.79 | 0.51 |
| 12.78 | | | 0.79 | 0.51 |
| 12.93 | | | 0.79 | 0.51 |
| 13.08 | | | 0.79 | 0.51 |
| 13.23 | | | 0.79 | 0.51 |
| 13.38 | | | 0.79 | 0.51 |
| 13.53 | | | 0.79 | 0.51 |
| 13.68 | | | 0.79 | 0.51 |
| 13.83 | | | 0.79 | 0.51 |
| 13.98 | | | 0.79 | 0.51 |
| 14.13 | | | 0.79 | 0.51 |
| 14.28 | | | 0.79 | 0.51 |
| 14.43 | | | 0.79 | 0.51 |
| 14.58 | | | 0.79 | 0.51 |
| 14.73 | | | 0.79 | 0.51 |
| 14.88 | | | 0.79 | 0.51 |
| 15.03 | | | 0.79 | 0.51 |

METRIC

| DATE | DATE | DESCRIPTION | SCALE | REV |
|----------|----------|-------------------------------|----------|-----|
| 09/28/18 | 09/28/18 | APPROVAL OF THE DESIGN | AS SHOWN | 01 |
| 09/28/18 | 09/28/18 | APPROVAL OF THE MANUFACTURING | AS SHOWN | 01 |
| 09/28/18 | 09/28/18 | APPROVAL OF THE MARKETING | AS SHOWN | 01 |
| 09/28/18 | 09/28/18 | APPROVAL OF THE SALES | AS SHOWN | 01 |
| 09/28/18 | 09/28/18 | APPROVAL OF THE SUPPORT | AS SHOWN | 01 |
| 09/28/18 | 09/28/18 | APPROVAL OF THE SUPPLY | AS SHOWN | 01 |
| 09/28/18 | 09/28/18 | APPROVAL OF THE FINISH | AS SHOWN | 01 |
| 09/28/18 | 09/28/18 | APPROVAL OF THE MATERIALS | AS SHOWN | 01 |
| 09/28/18 | 09/28/18 | APPROVAL OF THE PACKAGING | AS SHOWN | 01 |
| 09/28/18 | 09/28/18 | APPROVAL OF THE SHIPPING | AS SHOWN | 01 |
| 09/28/18 | 09/28/18 | APPROVAL OF THE STORAGE | AS SHOWN | 01 |
| 09/28/18 | 09/28/18 | APPROVAL OF THE DISTRIBUTION | AS SHOWN | 01 |

40.104 Apple Watch Series 5 Ceramic, 44 mm

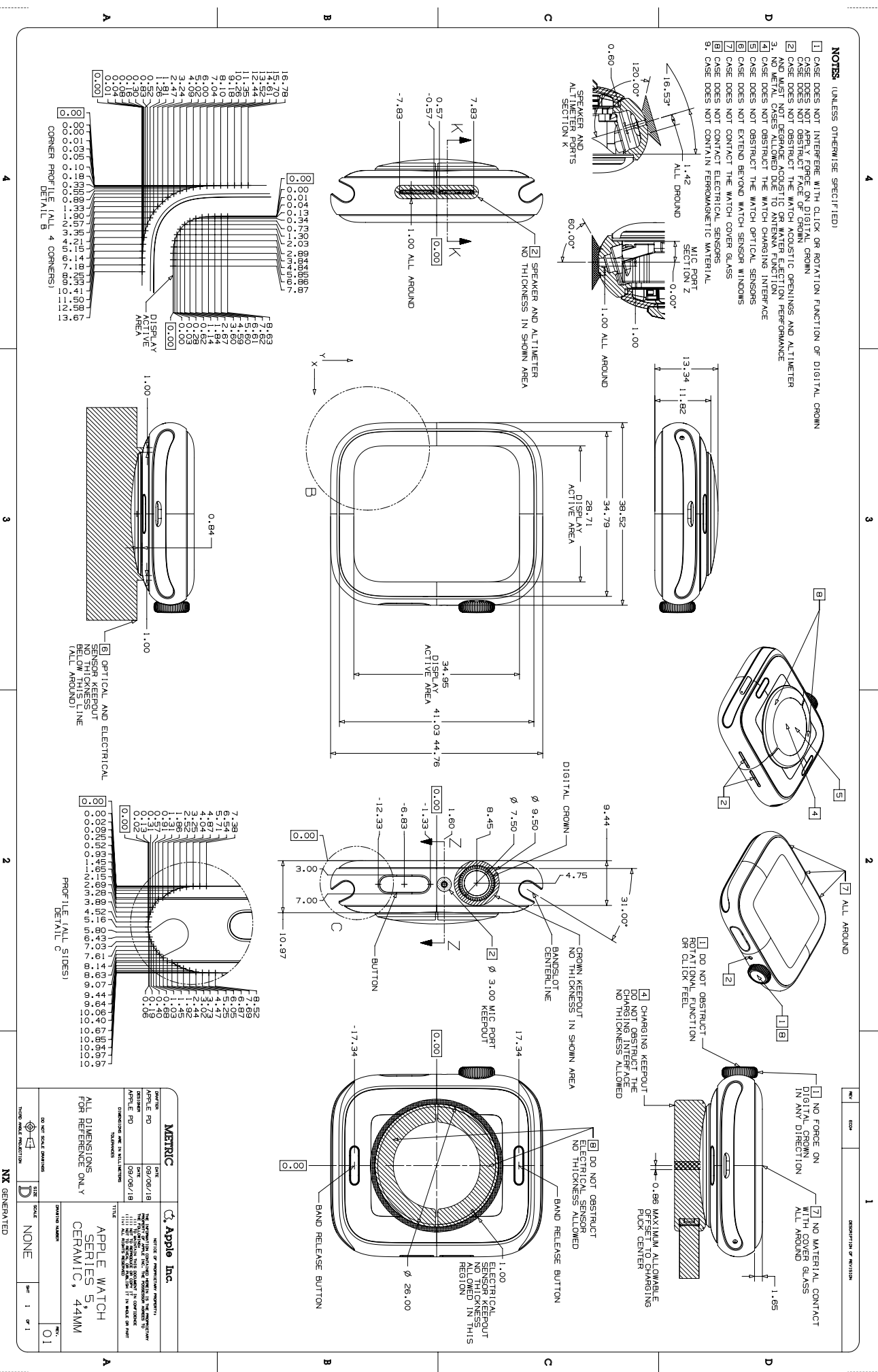

40.105 Apple Watch Series 5 Ceramic, 40 mm

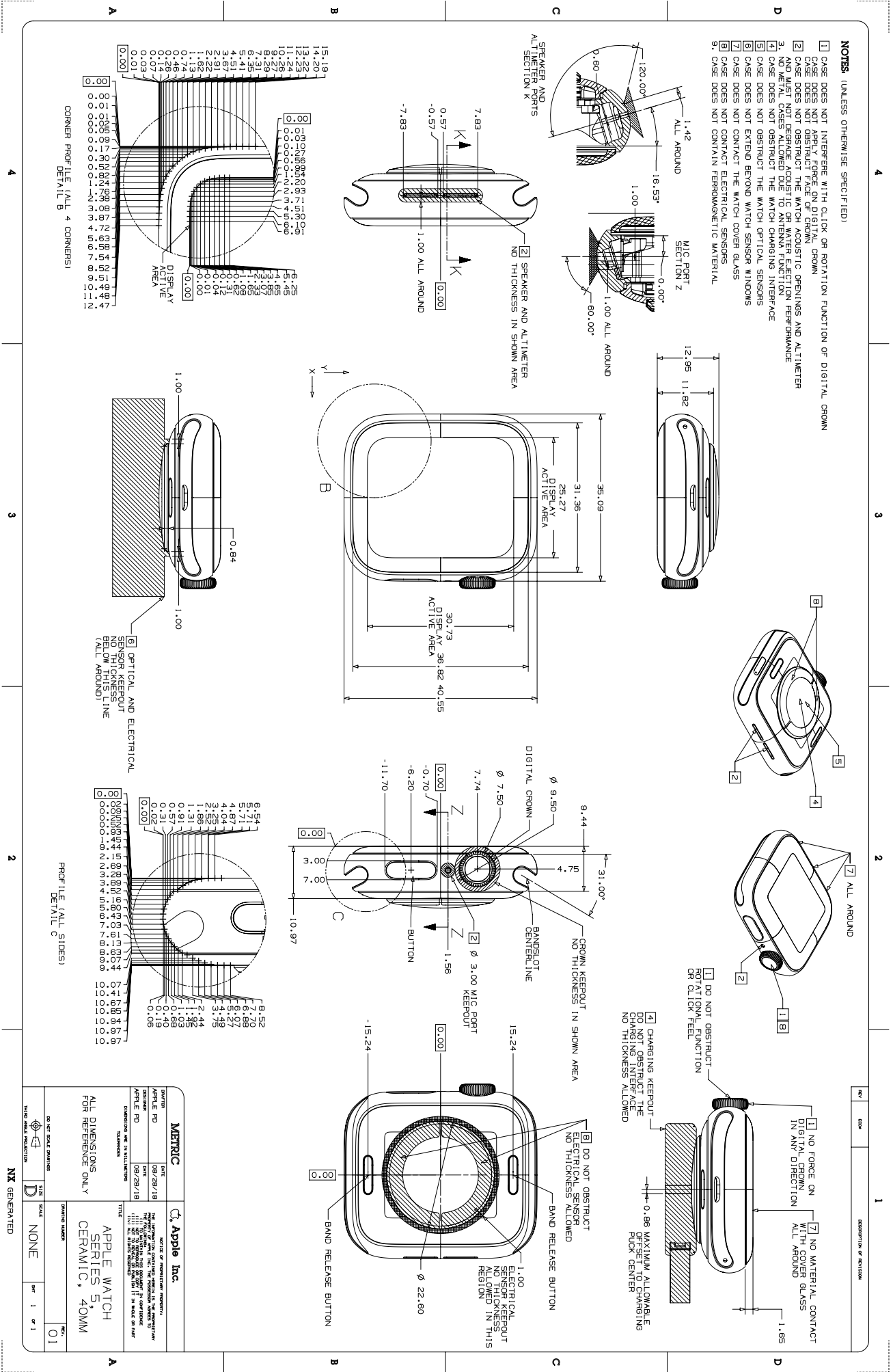

15.18
13.22
12.23
11.24
10.25
9.26
8.27
7.28
6.29
5.30
4.31
3.32
2.33
1.34
0.35
0.36
0.37
0.38
0.39
0.40
0.41
0.42
0.43
0.44
0.45
0.46
0.47
0.48
0.49
0.50
0.51
0.52
0.53
0.54
0.55
0.56
0.57
0.58
0.59
0.60
0.61
0.62
0.63
0.64
0.65
0.66
0.67
0.68
0.69
0.70
0.71
0.72
0.73
0.74
0.75
0.76
0.77
0.78
0.79
0.80
0.81
0.82
0.83
0.84
0.85
0.86
0.87
0.88
0.89
0.90
0.91
0.92
0.93
0.94
0.95
0.96
0.97
0.98
0.99
1.00

| METRIC | | DATE | | SCALE | | REV | |
|-------------|----------|-------|------|-------|---|-----|---|
| DATE | 09/28/18 | SCALE | NONE | REV | 1 | OF | 1 |
| APPROVED BY | | DATE | | SCALE | | REV | |
| DESIGNED BY | | DATE | | SCALE | | REV | |
| CHECKED BY | | DATE | | SCALE | | REV | |
| DATE | 09/28/18 | SCALE | NONE | REV | 1 | OF | 1 |
| APPROVED BY | | DATE | | SCALE | | REV | |
| DESIGNED BY | | DATE | | SCALE | | REV | |
| CHECKED BY | | DATE | | SCALE | | REV | |
| DATE | 09/28/18 | SCALE | NONE | REV | 1 | OF | 1 |

Apple Inc.
Apple Watch Series 5, 40mm Ceramic, 40mm

40.108 Apple Watch Series 3 Ceramic, 42 mm

NOTES (UNLESS OTHERWISE SPECIFIED)

- 1 CASE DOES NOT INTERFERE WITH CLICK OR ROTATION FUNCTION OF DIGITAL CROWN
- 2 CASE DOES NOT APPLY FORCE ON DIGITAL CROWN
- 3 CASE DOES NOT OBSTRUCT THE WATCH ACOUSTIC OPENINGS AND ALTIMETER
- 4 CASE DOES NOT OBSTRUCT THE WATCH ANTENNA WITH METAL
- 5 CASE DOES NOT OBSTRUCT THE WATCH CHARGING INTERFACE
- 6 CASE DOES NOT OBSTRUCT THE WATCH OPTICAL SENSORS
- 7 CASE DOES NOT EXTEND BEYOND WATCH SENSOR WINDOWS
- 8 CASE DOES NOT CONTACT THE WATCH COVER GLASS

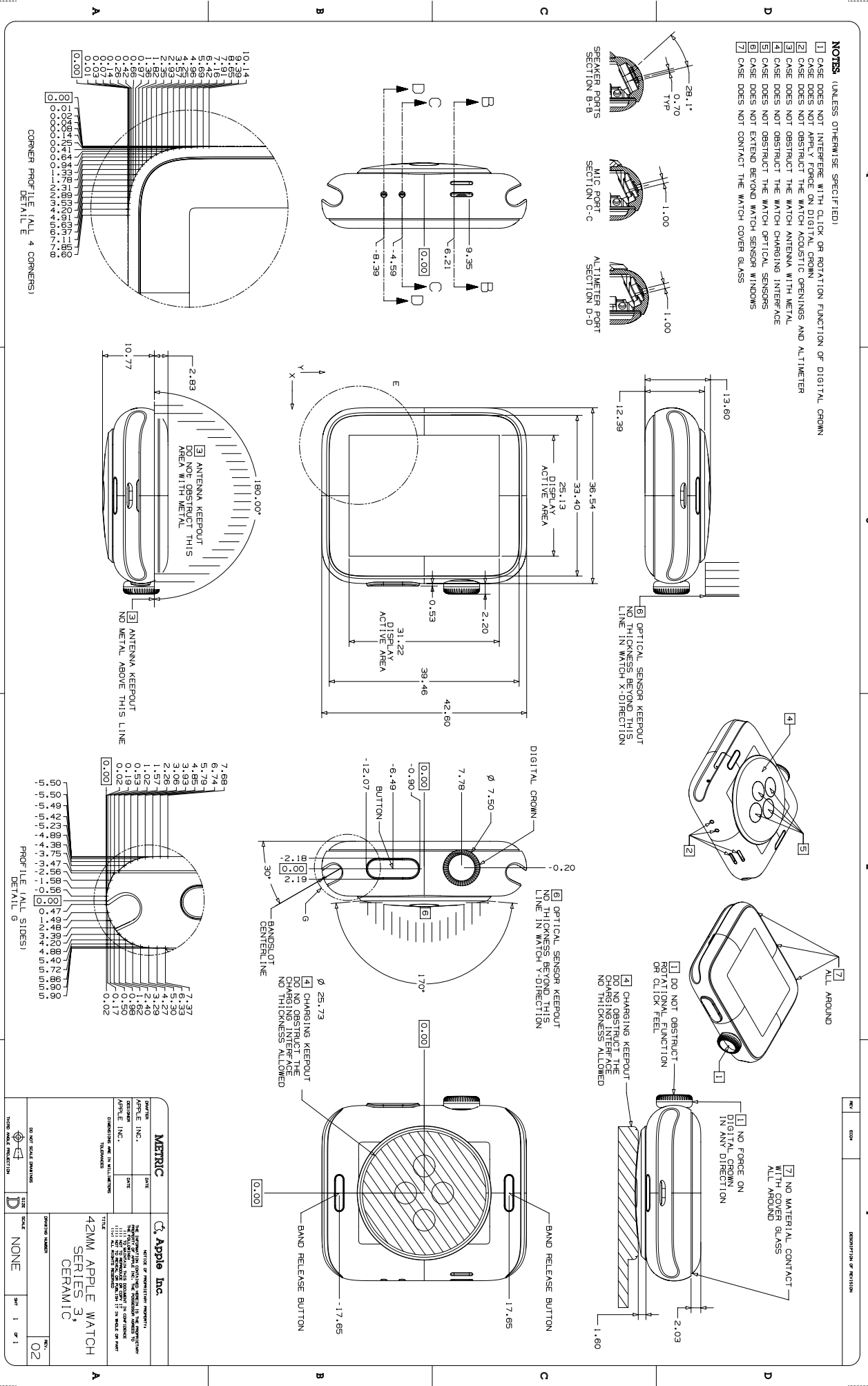

| METRIC | | Description of Revision | |
|--------|-----|-------------------------|-------------|
| DATE | REV | REV | DESCRIPTION |
| 02 | 1 | | |

Apple Inc.

Apple Inc. reserves the right to modify this document without notice. All rights reserved.

42MM APPLE WATCH SERIES 3 CERAMIC

Apple Inc. 100 Apple Park Blvd. Cupertino, CA 95014

Copyright © 2020 Apple Inc. All rights reserved.

268

40.109 Apple Watch Series 3 Ceramic, 38 mm

NOTES (UNLESS OTHERWISE SPECIFIED)

- CASE DOES NOT INTERFERE WITH CLICK OR ROTATION FUNCTION OF DIGITAL CROWN
- CASE DOES NOT APPLY FORCE ON DIGITAL CROWN
- CASE DOES NOT OBSTRUCT THE WATCH ADJUSTIVE OPENINGS AND ALLIUMETER
- CASE DOES NOT OBSTRUCT THE WATCH ANTENNA WITH METAL
- CASE DOES NOT OBSTRUCT THE WATCH CHARGING INTERFACE
- CASE DOES NOT OBSTRUCT THE WATCH OPTICAL SENSORS
- CASE DOES NOT EXTEND BEYOND WATCH SENSOR WINDOWS
- CASE DOES NOT CONTACT THE WATCH COVER GLASS

1 NO FORCE ON DIGITAL CROWN IN ANY DIRECTION

2 ALL AROUND

3 OPTICAL SENSOR KEEPOUT NO THICKNESS BEYOND THIS LINE IN WATCH X DIRECTION

4 CHARGING KEEPOUT DO NOT OBSTRUCT THE CHARGING INTERFACE NO THICKNESS ALLOWED

5 BAND RELEASE BUTTON

6 BAND RELEASE BUTTON

7 DO NOT OBSTRUCT ROTATION FUNCTION OR CLICK FEEL

8 NO THICKNESS BEYOND THIS LINE IN WATCH Y DIRECTION

9 CHARGING KEEPOUT DO NOT OBSTRUCT THE CHARGING INTERFACE NO THICKNESS ALLOWED

10 OPTICAL SENSOR KEEPOUT NO THICKNESS BEYOND THIS LINE IN WATCH X DIRECTION

11 OPTICAL SENSOR KEEPOUT NO THICKNESS BEYOND THIS LINE IN WATCH Y DIRECTION

12 BANDSLOT CENTERLINE

13 CHARGING KEEPOUT DO NOT OBSTRUCT THE CHARGING INTERFACE NO THICKNESS ALLOWED

14 BAND RELEASE BUTTON

15 CORNER PROFILE (ALL 4 CORNERS)

| |
|-------|
| 0.00 |
| 0.00 |
| 0.01 |
| 0.04 |
| 0.07 |
| 0.14 |
| 0.25 |
| 0.42 |
| 0.91 |
| 1.27 |
| 1.63 |
| 2.11 |
| 2.71 |
| 3.49 |
| 4.56 |
| 6.03 |
| 7.88 |
| 10.18 |
| 12.99 |
| 16.32 |

16 ANTENNA KEEPOUT NO METAL ABOVE THIS LINE

17 ANTENNA KEEPOUT THIS AREA WITH METAL

18 PROFILE (ALL SIDES)

| |
|--------|
| 0.00 |
| 0.08 |
| 0.13 |
| 0.89 |
| 1.55 |
| 2.28 |
| 3.14 |
| 4.14 |
| 5.17 |
| 6.22 |
| 7.32 |
| 8.44 |
| 9.67 |
| 11.00 |
| 12.43 |
| 13.94 |
| 15.52 |
| 17.16 |
| 18.85 |
| 20.58 |
| 22.34 |
| 24.13 |
| 25.94 |
| 27.76 |
| 29.60 |
| 31.45 |
| 33.31 |
| 35.18 |
| 37.06 |
| 38.95 |
| 40.84 |
| 42.73 |
| 44.63 |
| 46.52 |
| 48.41 |
| 50.3 |
| 52.18 |
| 54.07 |
| 55.95 |
| 57.83 |
| 59.7 |
| 61.57 |
| 63.44 |
| 65.3 |
| 67.17 |
| 69.03 |
| 70.88 |
| 72.72 |
| 74.55 |
| 76.38 |
| 78.2 |
| 80.02 |
| 81.83 |
| 83.63 |
| 85.42 |
| 87.2 |
| 88.98 |
| 90.77 |
| 92.54 |
| 94.31 |
| 96.07 |
| 97.82 |
| 99.56 |
| 101.3 |
| 103.04 |
| 104.73 |
| 106.41 |
| 108.08 |
| 109.73 |
| 111.37 |
| 113 |
| 114.61 |
| 115.9 |
| 117.17 |
| 118.43 |
| 119.68 |
| 120.91 |
| 122.12 |
| 123.32 |
| 124.5 |
| 125.67 |
| 126.78 |
| 127.87 |
| 128.94 |
| 130 |

| METRIC | |
|---|------|
| APPLE INC. | DATE |
| DESIGNED BY | DATE |
| CHECKED BY | DATE |
| APPROVED BY | DATE |
| TOLERANCES | |
| UNLESS OTHERWISE SPECIFIED: | |
| FRAMES | |
| OTHER | |
| DRAWING NUMBER: APPLE WATCH SERIES 3, 38MM, CERAMIC | |
| DRAWING SCALE: NONE | |
| DRAWING SHEET: 1 OF 1 | |

DO NOT SCALE DIMENSIONS

HIDDEN DIMENSIONS

DATE GENERATED: NX

40.110 Apple Watch Series 3 Metal, 42 mm

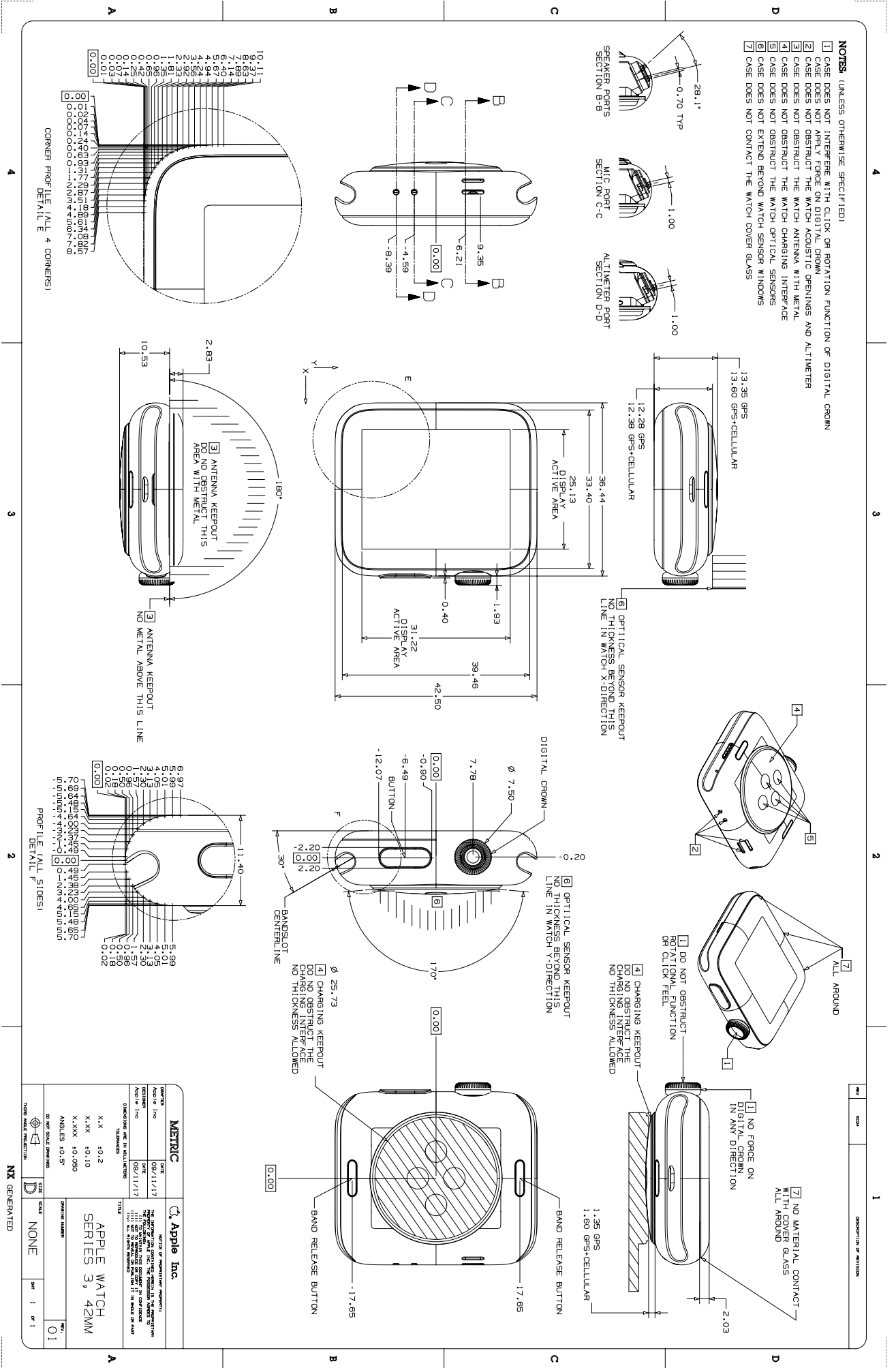

| METRIC | | Apple Inc. | |
|--|---------|----------------------------|---------|
| DATE | VERSION | DATE | VERSION |
| 09/11/17 | 1 | 09/11/17 | 1 |
| THE INFORMATION CONTAINED HEREIN IS CONFIDENTIAL AND PROPRIETARY TO APPLE INC. AND IS TO BE USED ONLY FOR THE PURPOSES SPECIFIED HEREIN. | | | |
| ALL RIGHTS RESERVED. NO PART OF THIS DOCUMENT IS TO BE REPRODUCED OR TRANSMITTED IN ANY FORM OR BY ANY MEANS, ELECTRONIC OR MECHANICAL, INCLUDING PHOTOCOPYING, RECORDING, OR BY ANY INFORMATION STORAGE AND RETRIEVAL SYSTEM, WITHOUT PERMISSION IN WRITING FROM APPLE INC. | | | |
| DRAWING NO. 40.110.000 | | TITLE | |
| 40.110.000 | | APPLE WATCH SERIES 3, 42MM | |
| ANGLES: 10.5° | | DRAWING NUMBER | |
| X.XX ±0.2 | | NONE | |
| X.XXX ±0.10 | | SCALE | |
| X.XXX ±0.050 | | NONE | |
| DO NOT SCALE DIMENSIONS | | SHEET | |
| HIDDEN LINE REJECTION | | 1 OF 1 | |

NX GENERATED

40.111 Apple Watch Series 3 Metal, 38 mm

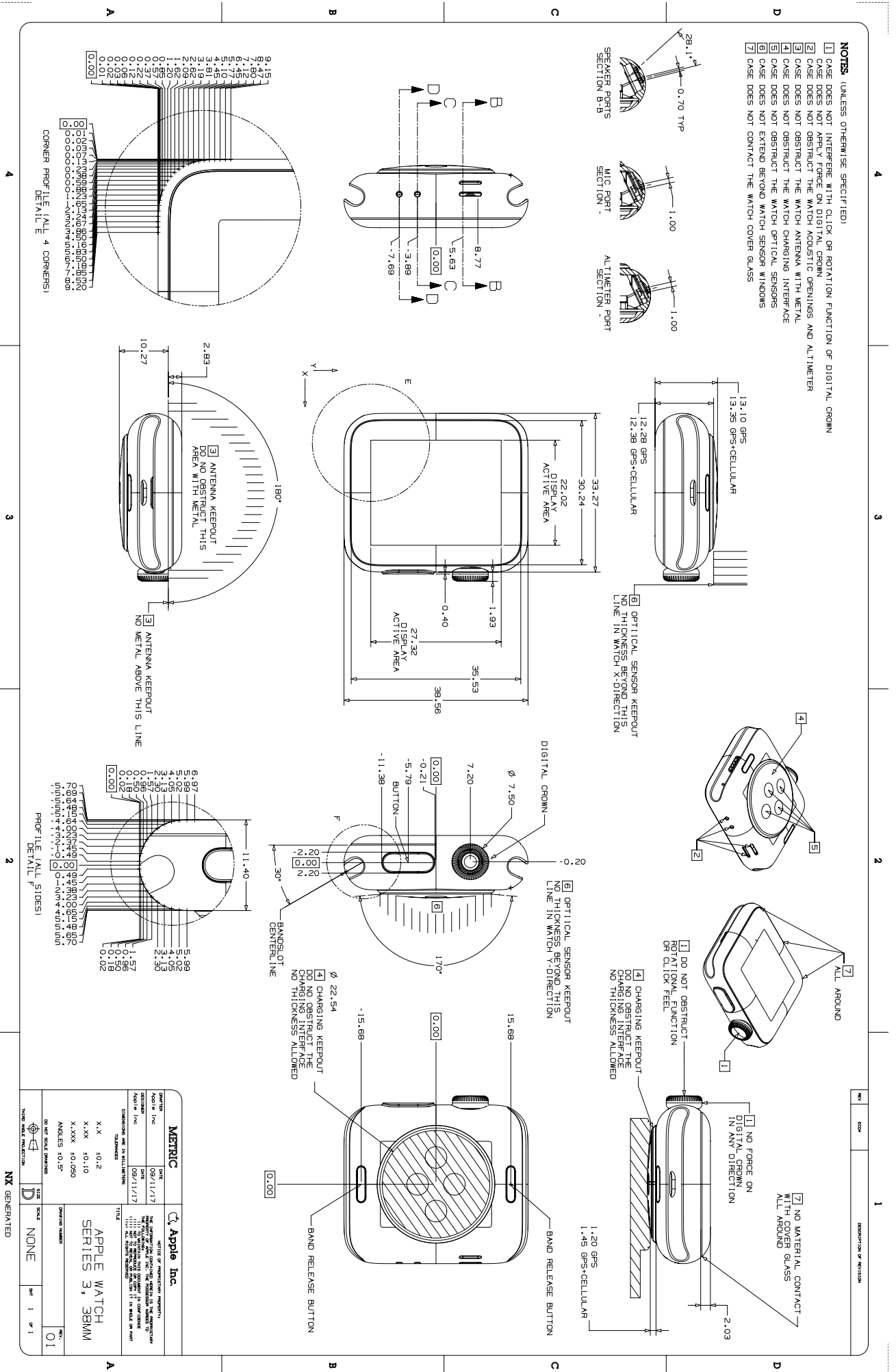

40.112 Apple Watch Series 2 Ceramic, 42 mm

NOTES (UNLESS OTHERWISE SPECIFIED)

- 1 CASE DOES NOT INTERFERE WITH CLICK OR ROTATION FUNCTION OF DIGITAL CROWN
- 2 CASE DOES NOT APPLY FORCE ON DIGITAL CROWN
- 3 CASE DOES NOT OBSTRUCT THE WATCH ACOUSTIC OPENINGS AND ALTIMETER
- 4 CASE DOES NOT OBSTRUCT THE WATCH ANTENNA WITH METAL
- 5 CASE DOES NOT OBSTRUCT THE WATCH CHARGING INTERFACE
- 6 CASE DOES NOT OBSTRUCT THE WATCH OPTICAL SENSORS
- 7 CASE DOES NOT EXTEND BEYOND WATCH SENSOR WINDOWS
- 8 CASE DOES NOT CONTACT THE WATCH COVER GLASS

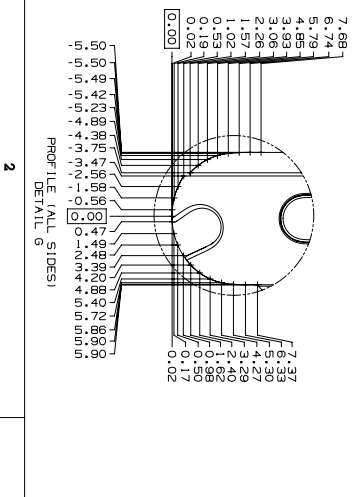
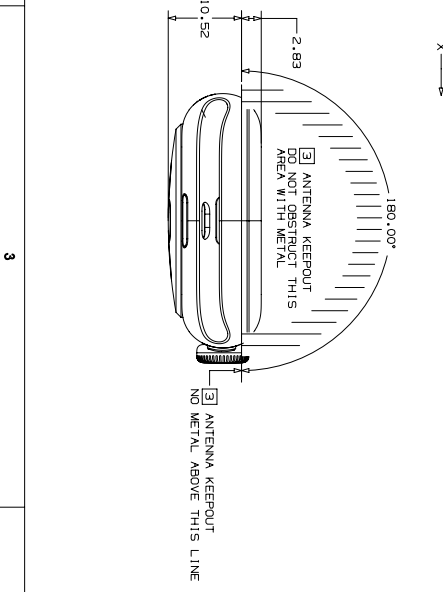
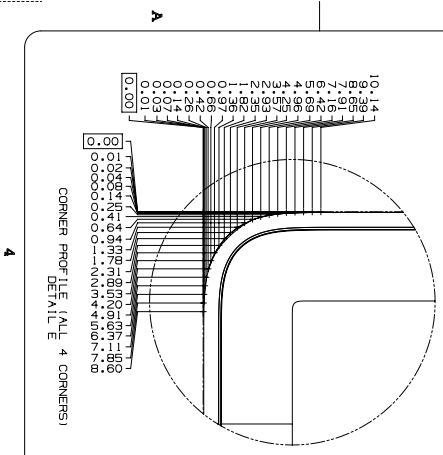
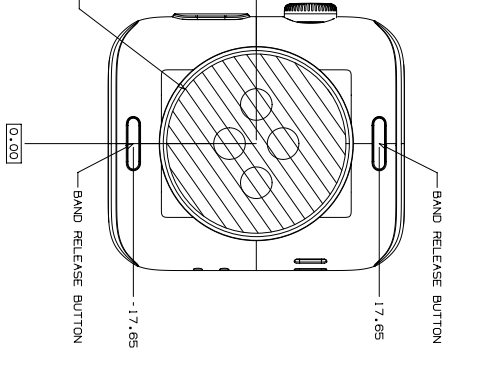
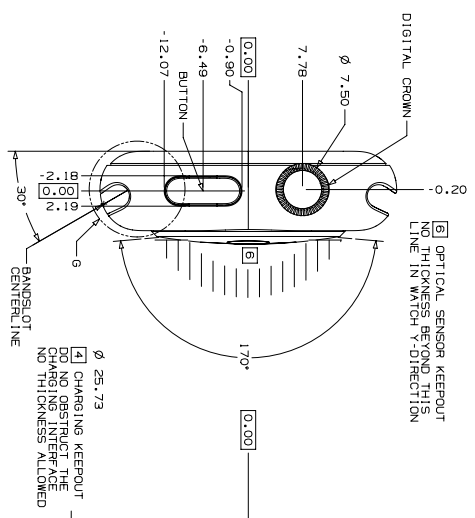
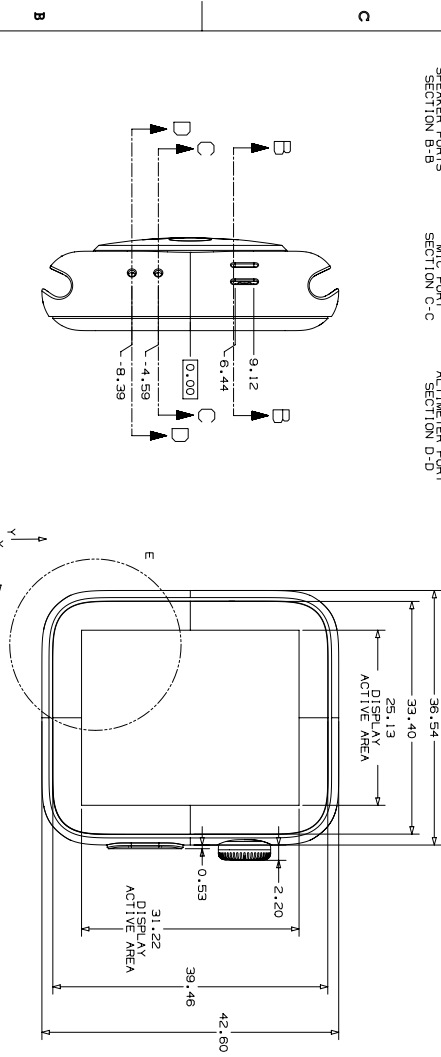
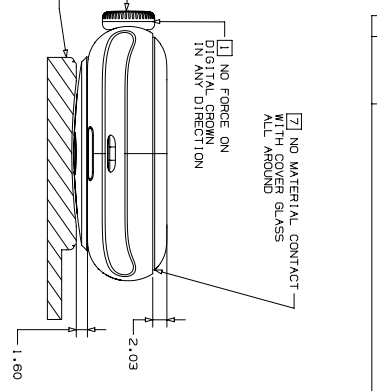
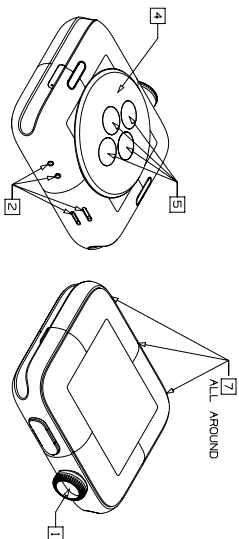
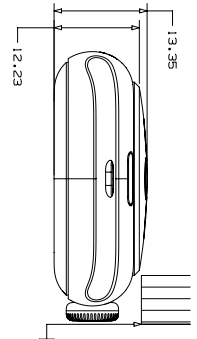
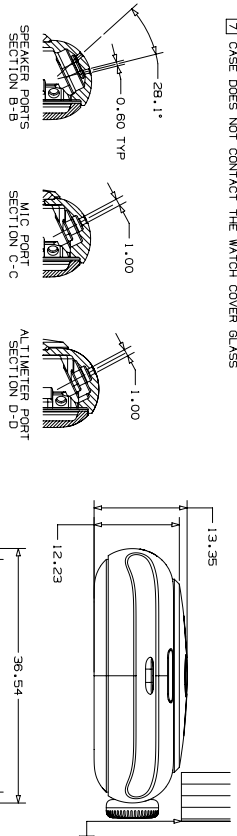

| | | | |
|----------------------|-----|-----------------------------------|-------------|
| METRIC | | Apple Inc. | |
| DATE | REV | DESCRIPTION | DATE |
| APR 11 2016 | 01 | 42MM APPLE WATCH SERIES 2 CERAMIC | APR 11 2016 |
| DRAWING NUMBER | | REV | |
| NONE | | 01 | |
| DO NOT SCALE DRAWING | | DRAWING SCALE | |
| NONE | | NONE | |
| HARD COPY PROJECTION | | SHEET 1 OF 1 | |
| NX GENERATED | | DATE | |
| | | APR 11 2016 | |

40.113 Apple Watch Series 2 Ceramic, 38 mm

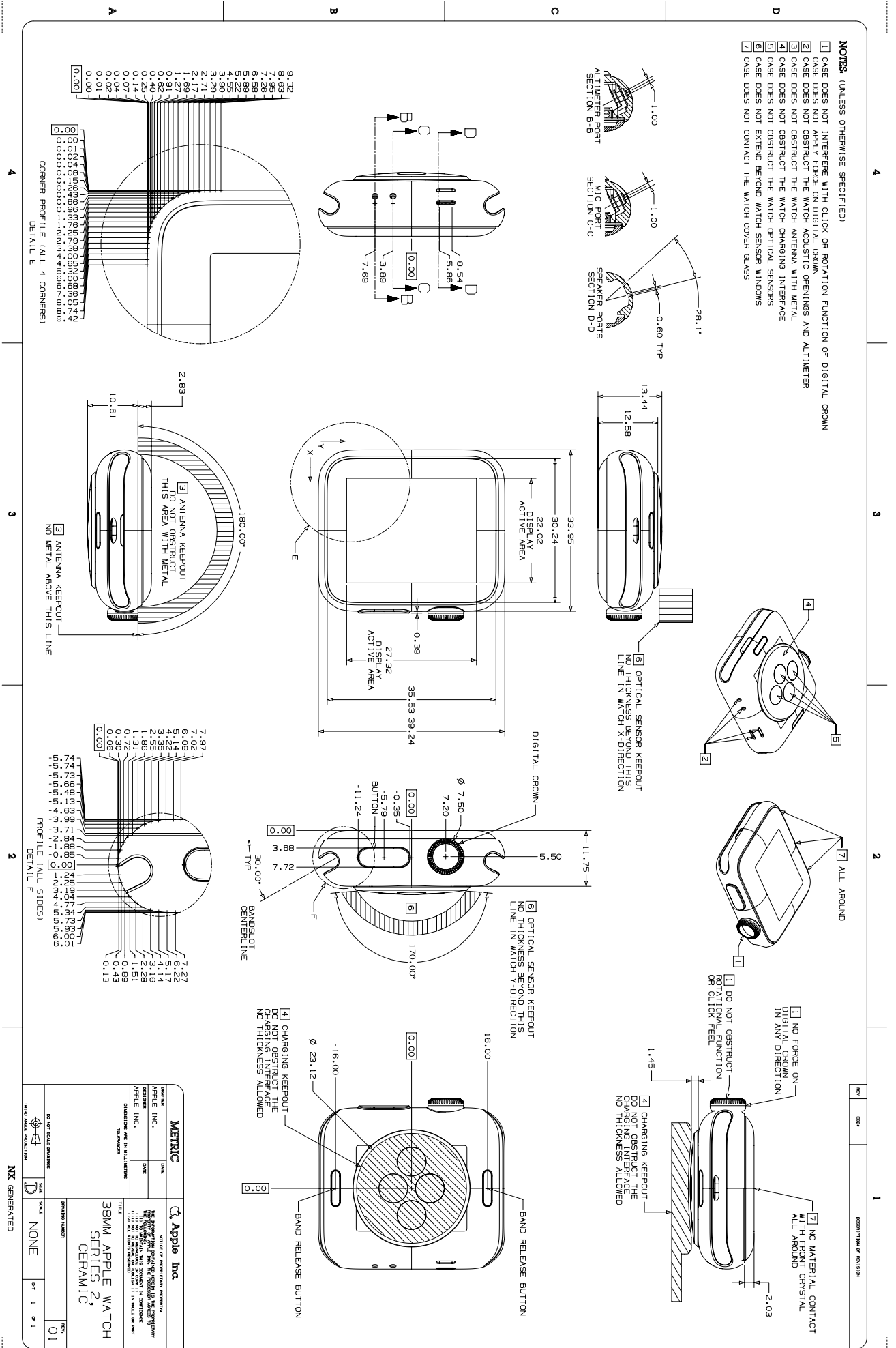

| NO. | SCALE | DESCRIPTION OF REVISION |
|-----|-------|-------------------------|
| 1 | | |

40.114 Apple Watch Series 2 Metal, 42 mm

NOTES (UNLESS OTHERWISE SPECIFIED):

- 1 CASE DOES NOT INTERFERE WITH CLICK OR ROTATION FUNCTION OF DIGITAL CROWN
- 2 CASE DOES NOT APPLY FORCE ON DIGITAL CROWN
- 3 CASE DOES NOT OBSTRUCT THE WATCH ACOUSTIC OPENINGS AND ALTIMETER
- 4 CASE DOES NOT OBSTRUCT THE WATCH ANTENNA WITH METAL
- 5 CASE DOES NOT OBSTRUCT THE WATCH CHARGING INTERFACE
- 6 CASE DOES NOT OBSTRUCT THE WATCH OPTICAL SENSORS
- 7 CASE DOES NOT EXTEND BEYOND WATCH SENSOR WINDOWS
- 8 CASE DOES NOT CONTACT THE WATCH COVER GLASS

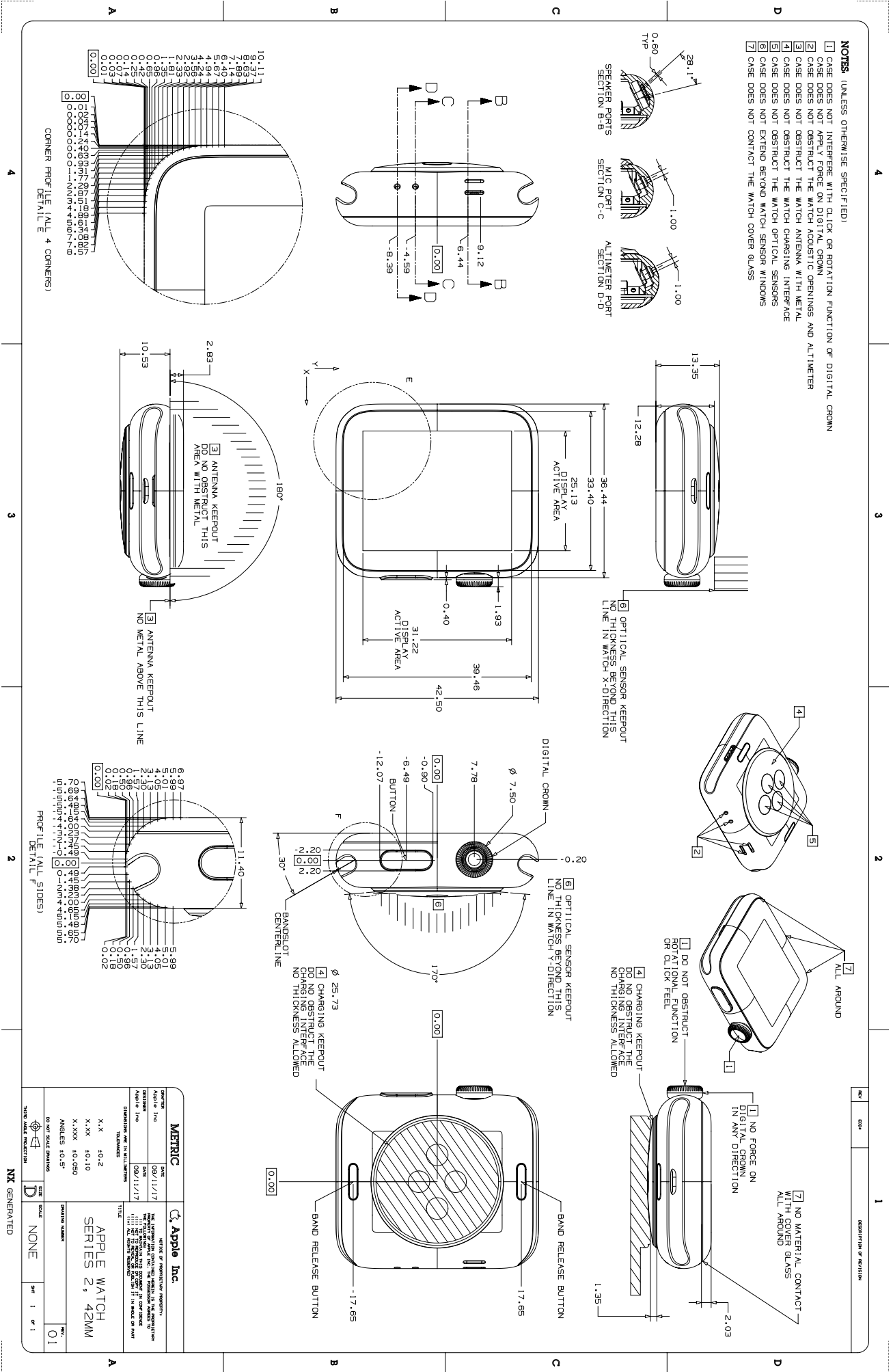

| METRIC | | Apple Inc. | |
|-------------|----------------------------|-------------|----------|
| Part No. | 09/11/17 | Part No. | 09/11/17 |
| Rev. No. | 1 | Rev. No. | 1 |
| DATE | 09/11/17 | DATE | 09/11/17 |
| DESIGNED BY | | DESIGNED BY | |
| CHECKED BY | | CHECKED BY | |
| APPROVED BY | | APPROVED BY | |
| DATE | | DATE | |
| DESCRIPTION | APPLE WATCH SERIES 2, 42MM | | |
| SCALE | NONE | | |
| DRW. NO. | 01 | | |

NX GENERATED

40.115 Apple Watch Series 2 Metal, 38 mm

NOTES (UNLESS OTHERWISE SPECIFIED)

- 1 CASE DOES NOT INTERFERE WITH CLICK OR ROTATION FUNCTION OF DIGITAL CROWN
- 2 CASE DOES NOT APPLY FORCE ON DIGITAL CROWN
- 3 CASE DOES NOT OBSTRUCT THE WATCH ACOUSTIC OPENINGS AND ALTIMETER
- 4 CASE DOES NOT OBSTRUCT THE WATCH ANTENNA WITH METAL
- 5 CASE DOES NOT OBSTRUCT THE WATCH CHARGING INTERFACE
- 6 CASE DOES NOT OBSTRUCT THE WATCH OPTICAL SENSORS
- 7 CASE DOES NOT EXTEND BEYOND WATCH SENSOR WINDOWS
- 8 CASE DOES NOT CONTACT THE WATCH COVER GLASS

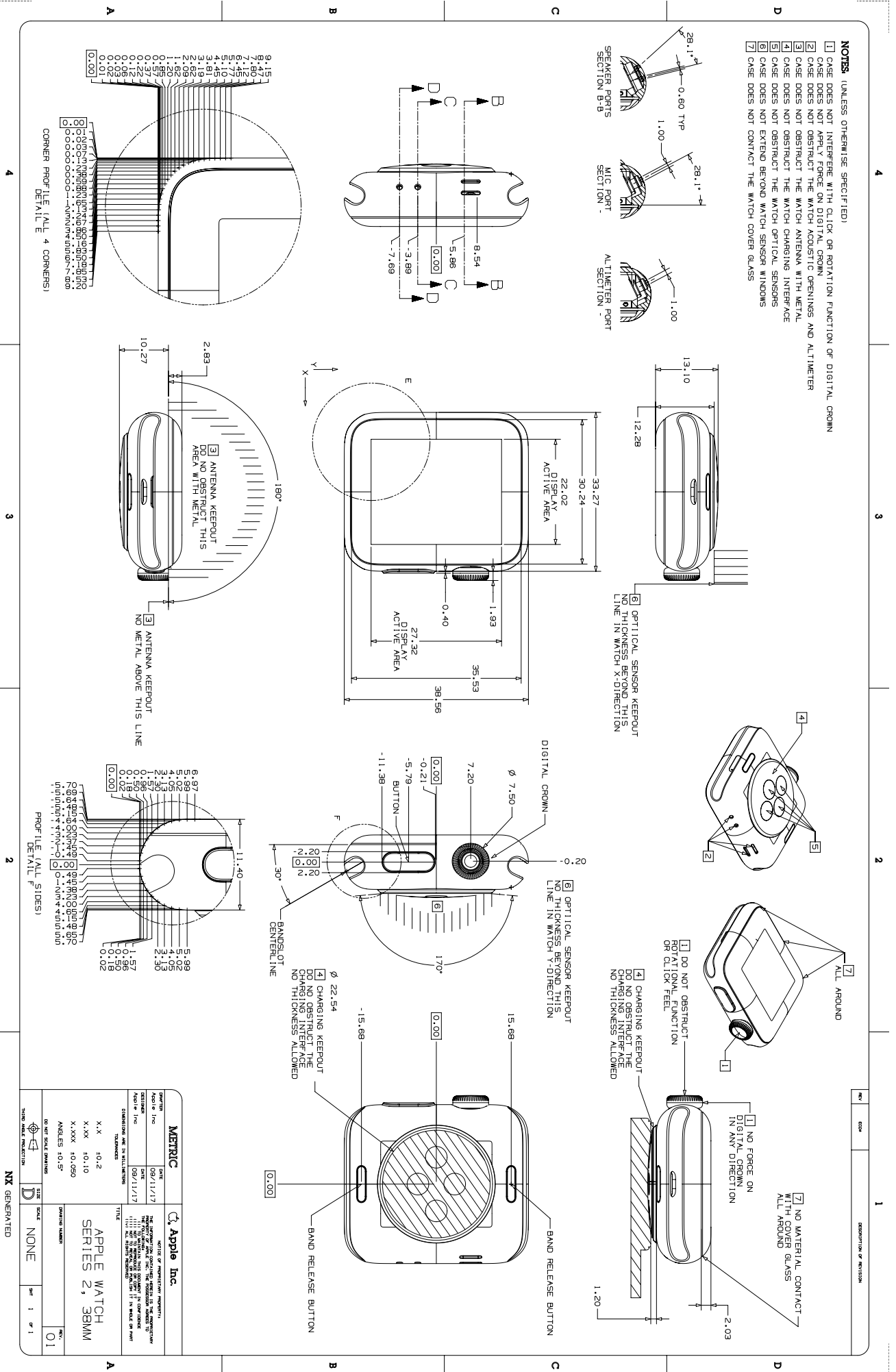

40.116 Apple Watch (1st generation) & Apple Watch Series 1, 42 mm

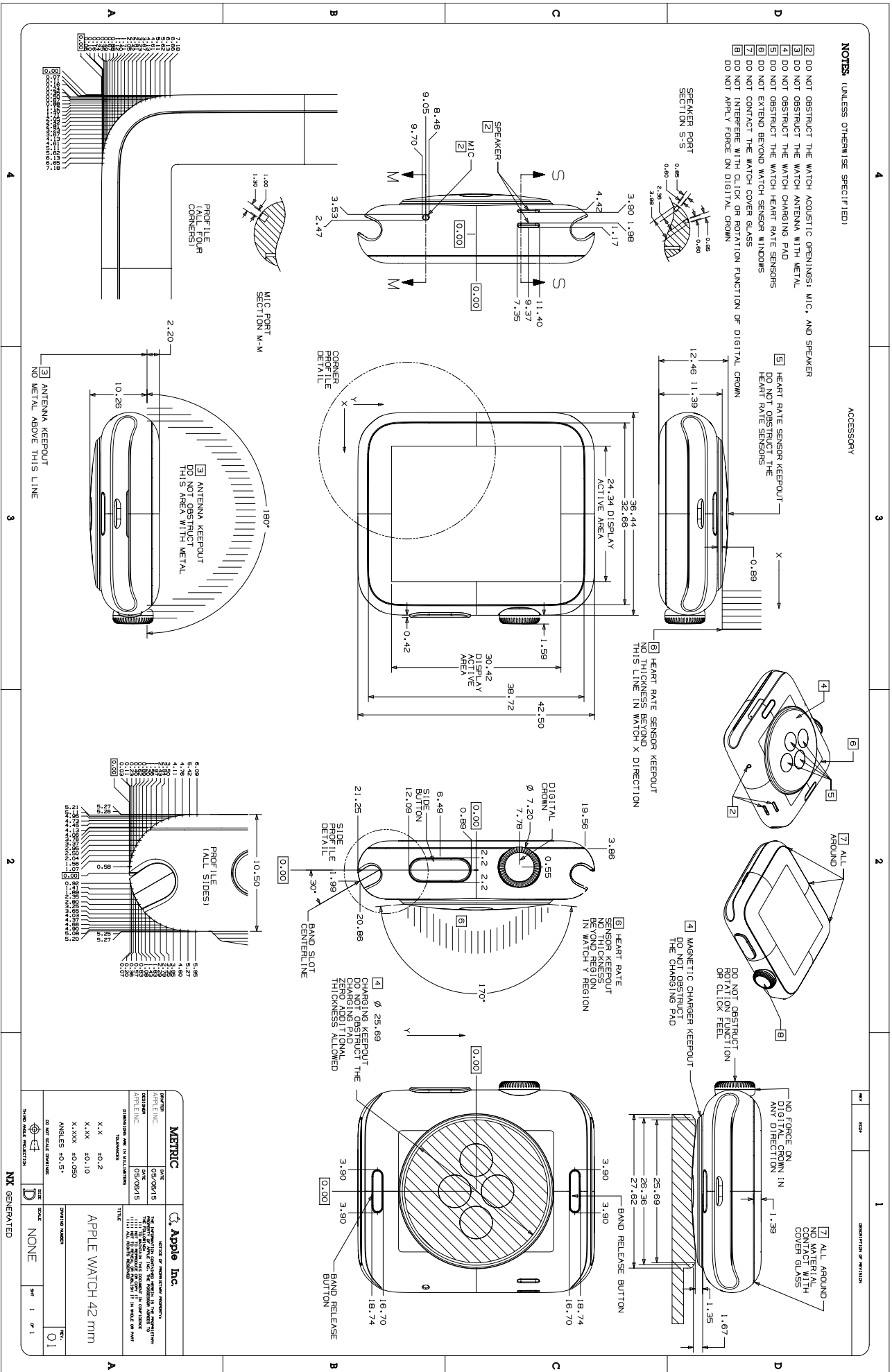

NOTES: (UNLESS OTHERWISE SPECIFIED)

ASSEMBLY:

- DO NOT OBSTRUCT THE WATCH ACOUSTIC OPENINGS: MIC, AND SPEAKER
- DO NOT OBSTRUCT THE WATCH ANTENNA WITH METAL
- DO NOT OBSTRUCT THE WATCH CHARGING PAD
- DO NOT OBSTRUCT THE WATCH HEART RATE SENSORS
- DO NOT EXTEND BEYOND WATCH SENSOR WINDOWS
- DO NOT INTERFERE WITH WATCH COVER GLASS
- DO NOT CONTACT THE WATCH COVER GLASS
- DO NOT INTERFERE WITH CLICK OR ROTATION FUNCTION OF DIGITAL CROWN
- DO NOT APPLY FORCE ON DIGITAL CROWN

ACCESSORY:

- HEART RATE SENSOR KEEPPOUT - DO NOT OBSTRUCT THE HEART RATE SENSORS
- HEART RATE SENSOR KEEPPOUT - HEART RATE SENSOR KEEPPOUT MUST BE TIGHTER IN WATCH X DIRECTION THAN THIS LINE
- HEART RATE SENSOR KEEPPOUT - ALL AROUND
- MAGNETIC CHARGER KEEPPOUT - DO NOT OBSTRUCT THE CHARGING PAD OR ROTATION FUNCTION OR CLICK FEEL
- HEART RATE SENSOR KEEPPOUT - DO NOT OBSTRUCT THE CHARGING PAD
- HEART RATE SENSOR KEEPPOUT - NO FORCE ON DIGITAL CROWN IN ANY DIRECTION
- ALL AROUND - NO MATERIAL CONTACT WITH COVER GLASS

FUNCTIONAL CONSTRAINTS:

- MIC: SECTION M-M, MIC PORT SECTION M-M
- ANTENNA KEEPPOUT: ANTENNA KEEPPOUT DO NOT OBSTRUCT THIS AREA WITH METAL
- ANTENNA KEEPPOUT: ANTENNA KEEPPOUT NO METAL ABOVE THIS LINE
- PROF. L.F. (ALL SIDES)
- DIGITAL CROWN: DIGITAL CROWN Ø 7.20
- BAND SLOT: BAND SLOT CENTRAL LINE
- BAND RELEASE BUTTON: BAND RELEASE BUTTON

| REV | DESCRIPTION | DATE | SCALE | BY |
|-----|-------------------------|----------|-------|--------|
| 1 | DESCRIPTION OF REVISION | 09/20/15 | NONE | 1 of 1 |
| 2 | | | | |
| 3 | | | | |
| 4 | | | | |

| NO | DATE | SCALE | BY |
|----|----------|-------|--------|
| 01 | 09/20/15 | NONE | 1 of 1 |

| DRAWING TABLE | | SCALE | BY |
|---------------|----------|-------|--------|
| ASSEMBLY | DATE | SCALE | BY |
| 01 | 09/20/15 | NONE | 1 of 1 |

| TITLE | DRAWING NUMBER |
|-------------------|----------------|
| APPLE WATCH 42 mm | 01 |

40.117 Apple Watch (1st generation) & Apple Watch Series 1, 38 mm

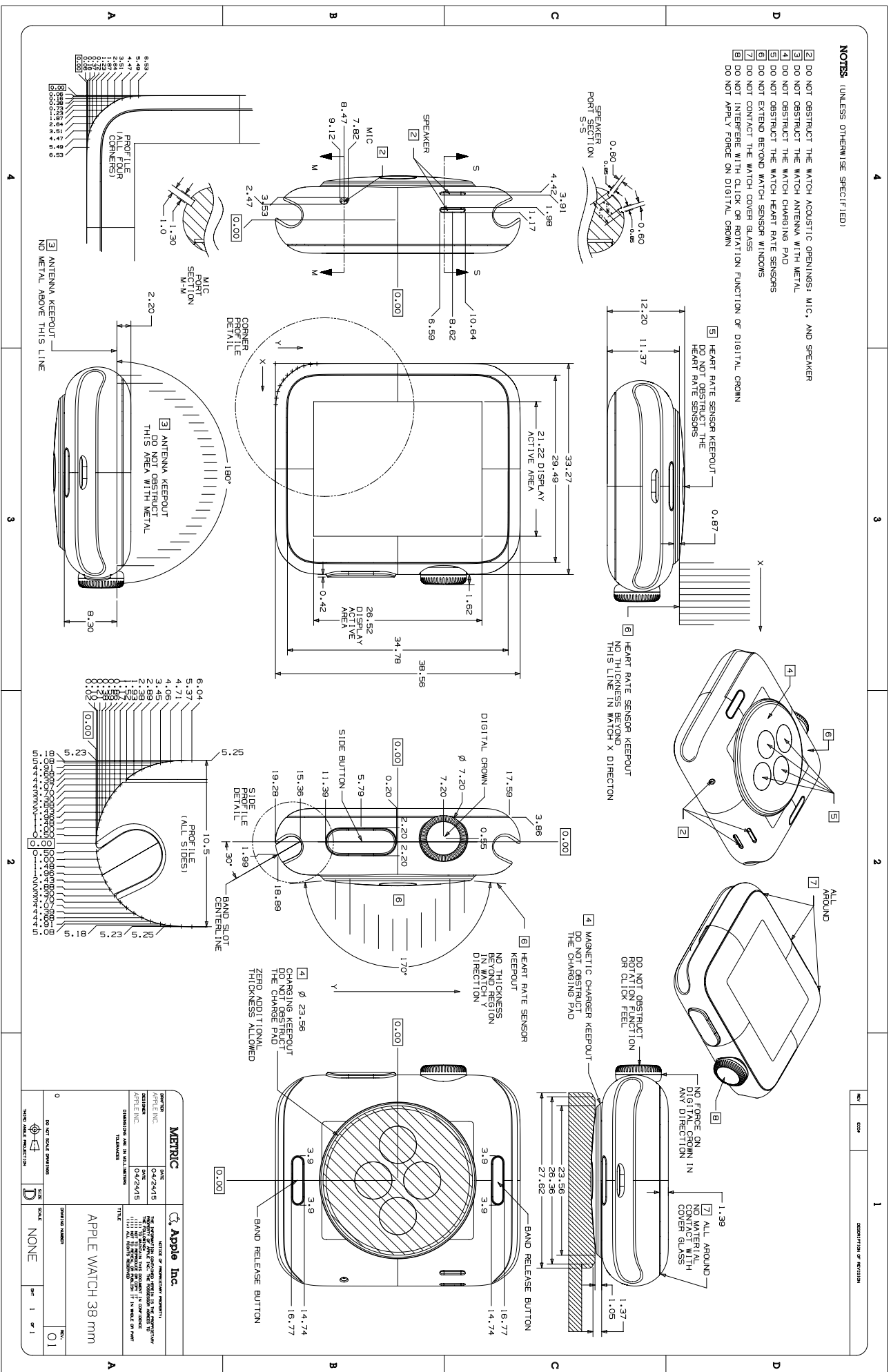

| METRIC | | Apple Inc. | |
|-----------------------------------|-------------|------------|----------|
| DATE | 04/24/15 | VERSION | 01 |
| APPROVED | [Signature] | DATE | 04/24/15 |
| DESIGNED | [Signature] | DATE | 04/24/15 |
| DRAWING NUMBER: APPLE WATCH 38 mm | | | |
| SCALE: NONE | | | |
| SHEET: 1 OF 1 | | | |

40.118 AirPods Pro Wireless Charging Case

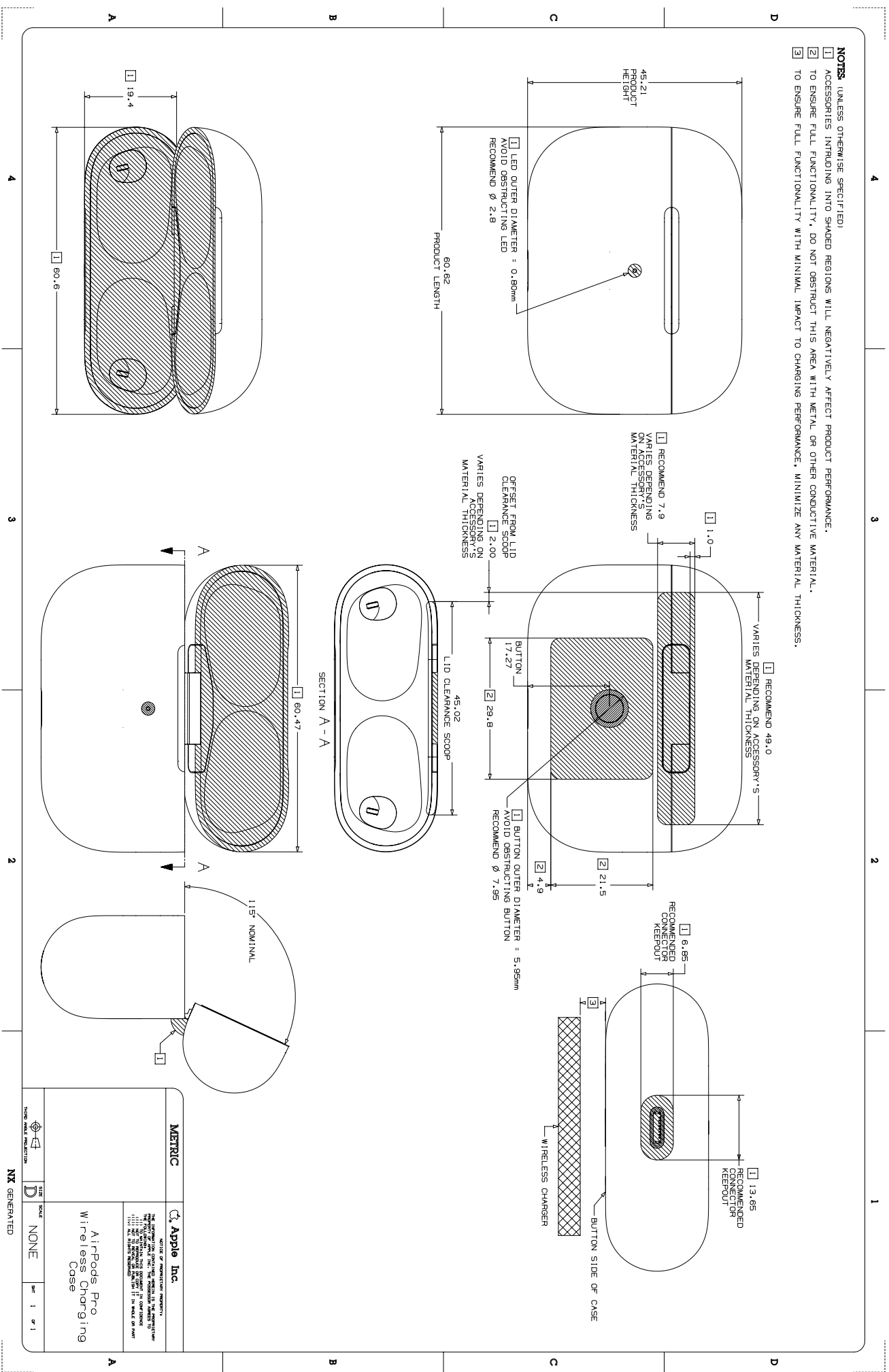

| | | | |
|--|------|---------------------------------------|--------------|
| METRIC | | Apple Inc. | |
| <small>THE INFORMATION CONTAINED HEREIN IS SUBJECT TO CHANGE WITHOUT NOTICE. THE INFORMATION IS PROVIDED AS IS, WITHOUT WARRANTY OF ANY KIND, INCLUDING MERCHANTABILITY AND FITNESS FOR A PARTICULAR PURPOSE. THE INFORMATION IS PROVIDED AS IS, WITHOUT WARRANTY OF ANY KIND, INCLUDING MERCHANTABILITY AND FITNESS FOR A PARTICULAR PURPOSE.</small> | | AirPods Pro Wireless Charging Case | |
| NONE | NONE | SHEET 1 OF 1 | NX GENERATED |

40.119 AirPods Wireless Charging Case

NOTES (UNLESS OTHERWISE SPECIFIED)

- 1 ACCESSORIES INTRUDING INTO SHADED REGIONS WILL NEGATIVELY AFFECT PRODUCT PERFORMANCE.
- 2 TO ENSURE FULL FUNCTIONALITY, DO NOT OBSTRUCT INDICATED AREA WITH METAL OR OTHER CONDUCTIVE MATERIAL.
- 3 TO ENSURE FULL FUNCTIONALITY WITH MINIMAL IMPACT TO CHARGING PERFORMANCE, MINIMIZE ANY MATERIAL THICKNESS.

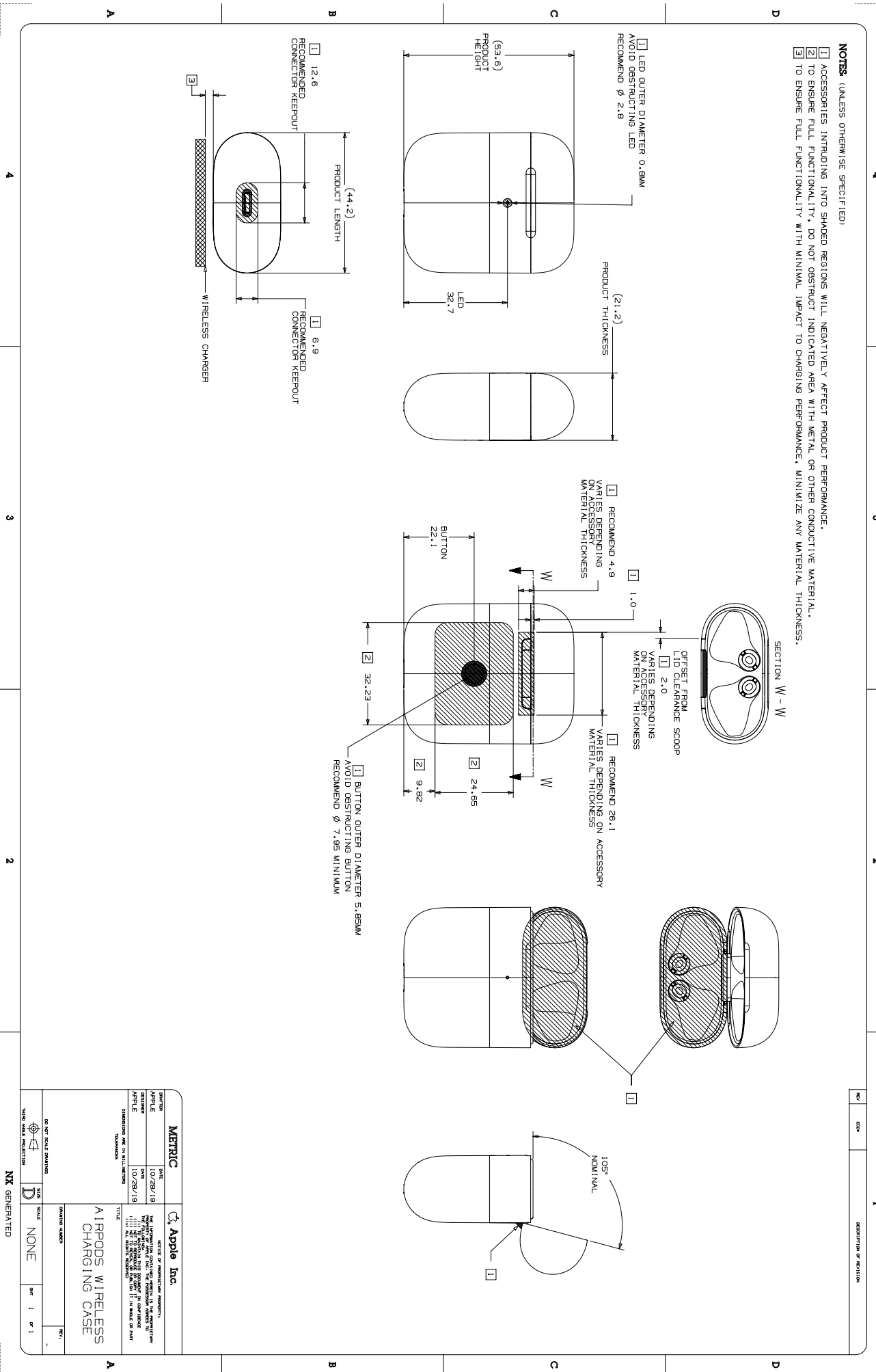

| | | | |
|--|--------------------------------|--|--------------------------------|
| METRIC | | Apple Inc. | |
| DATE | 10/28/18 | DATE | 10/28/18 |
| DESIGNED BY | APPLE | DESIGNED BY | APPLE |
| CHANGING NAME TO BULK PARTS | | CHANGING NAME TO BULK PARTS | |
| DO NOT SCALE DRAWINGS | | DO NOT SCALE DRAWINGS | |
| THIS DRAWING IS THE PROPERTY OF APPLE INC. IT IS TO BE USED ONLY FOR THE PURPOSES SPECIFIED AND IS NOT TO BE REPRODUCED OR TRANSMITTED IN ANY FORM OR BY ANY MEANS, ELECTRONIC OR MECHANICAL, INCLUDING PHOTOCOPYING, RECORDING, OR BY ANY INFORMATION STORAGE AND RETRIEVAL SYSTEM, WITHOUT PERMISSION IN WRITING FROM APPLE INC. | | THIS DRAWING IS THE PROPERTY OF APPLE INC. IT IS TO BE USED ONLY FOR THE PURPOSES SPECIFIED AND IS NOT TO BE REPRODUCED OR TRANSMITTED IN ANY FORM OR BY ANY MEANS, ELECTRONIC OR MECHANICAL, INCLUDING PHOTOCOPYING, RECORDING, OR BY ANY INFORMATION STORAGE AND RETRIEVAL SYSTEM, WITHOUT PERMISSION IN WRITING FROM APPLE INC. | |
| TITLE | AIRPODS WIRELESS CHARGING CASE | TITLE | AIRPODS WIRELESS CHARGING CASE |
| DRAWING NUMBER | NONE | DRAWING NUMBER | NONE |
| SCALE | 1 | SCALE | 1 |
| SHEET | 1 | SHEET | 1 |
| REV. | | REV. | |

NX GENERATED

40.120 AirPods Pro

| REV. | ESQA | DESCRIPTION OF REVISION |
|------|------|-------------------------|
| 1 | | |

NOTES: (UNLESS OTHERWISE SPECIFIED)
 [1] ACCESSORIES INTRUDING INTO SHADED REGIONS WILL NEGATIVELY AFFECT PRODUCT PERFORMANCE
 [2] ACCESSORIES MUST NOT COVER THESE METAL SURFACES

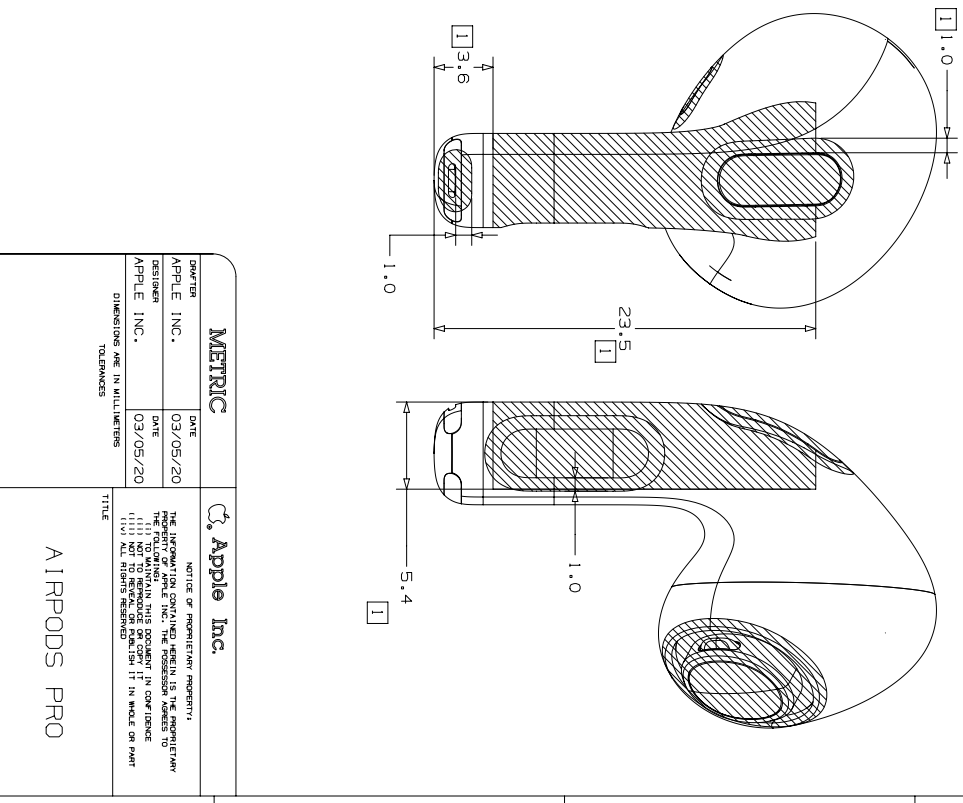
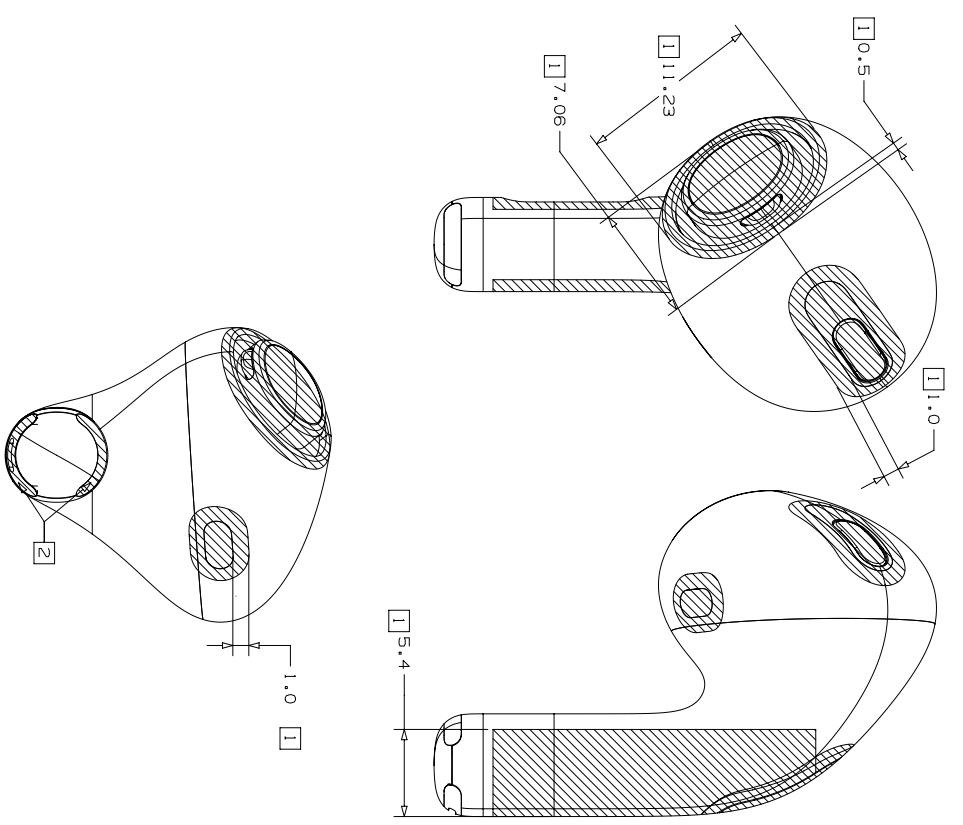

| METRIC | | DATE | | DRAWING NUMBER | | REV. | |
|-------------------------------|------------|------|----------|---|-------------|------|------|
| SHIPPER | APPLE INC. | DATE | 03/05/20 | DRAWING NUMBER | | | REV. |
| DESIGNER | APPLE INC. | DATE | 03/05/20 | TITLE | AIRPODS PRO | | 01 |
| DIMENSIONS ARE IN MILLIMETERS | | | | NOTICE OF PROPRIETARY INTEREST: | | | |
| TOLERANCES | | | | THE INFORMATION CONTAINED HEREIN IS THE PROPERTY OF APPLE INC. AND IS UNCLASSIFIED UNDER THE FOIA. IT IS NOT TO BE REPRODUCED OR TRANSMITTED IN ANY FORM OR BY ANY MEANS, ELECTRONIC OR MECHANICAL, INCLUDING PHOTOCOPYING, RECORDING, OR BY ANY INFORMATION STORAGE AND RETRIEVAL SYSTEM, WITHOUT PERMISSION IN WRITING FROM APPLE INC. ALL RIGHTS RESERVED. | | | |

| | | | | |
|------------------------|------|-------|----------------|--|
| DO NOT SCALE DRAWINGS | SIZE | SCALE | DRAWING NUMBER | |
| THIRD ANGLE PROJECTION | A | NONE | NX GENERATED | |

40.121 AirPods

- NOTES** (UNLESS OTHERWISE SPECIFIED)
- [1] ACCESSORIES INTRUDING INTO SHADED REGIONS WILL NEGATIVELY AFFECT PRODUCT PERFORMANCE.
 - [2] ACCESSORIES MUST NOT COVER THESE METAL SURFACES.

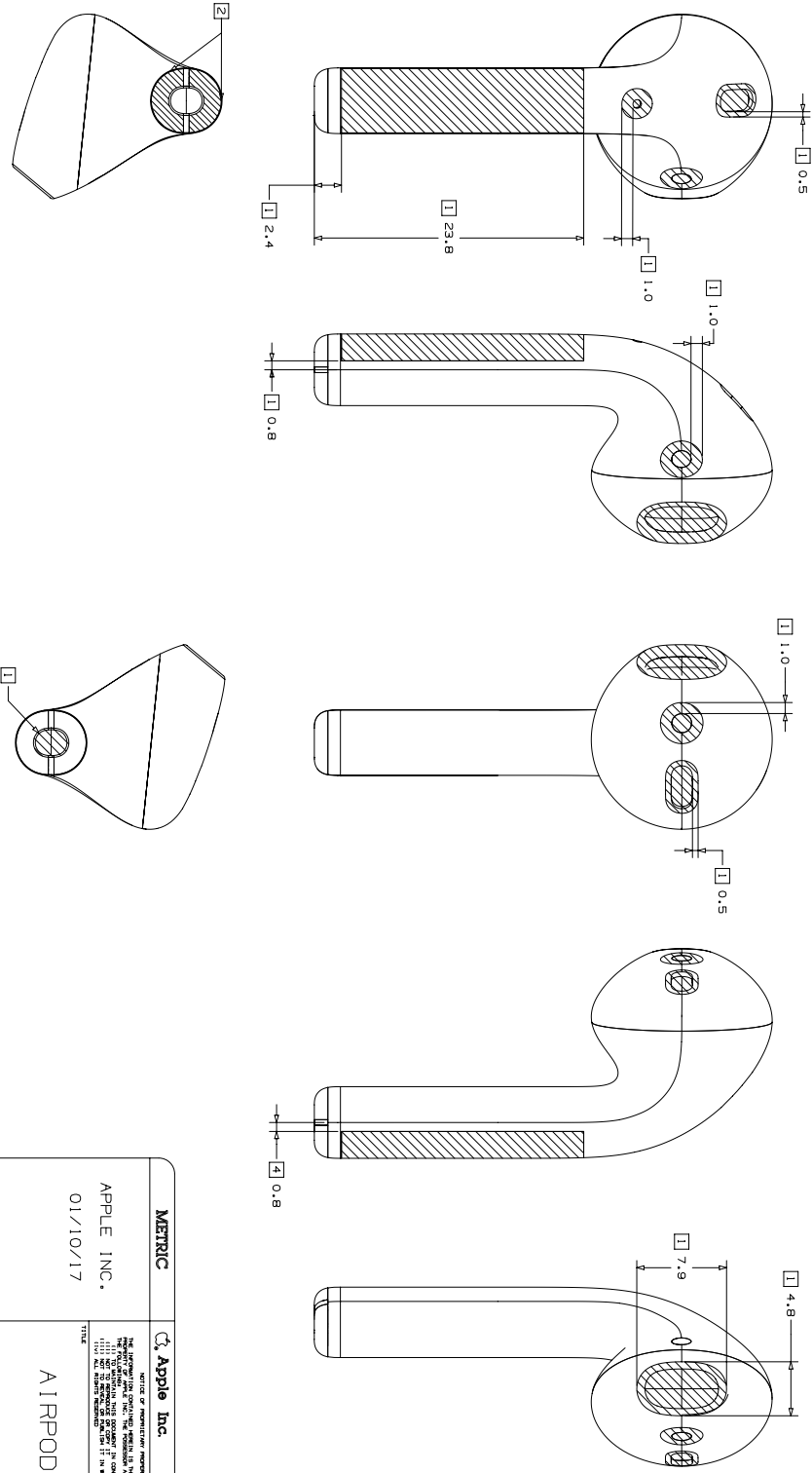

4 3 2 1

| | |
|---|---|
| METRIC | Apple Inc. |
| APPLE INC. 01/10/17 | <small>NOTICE OF REVISIONS AND OTHER INFORMATION The information on this drawing is the property of Apple Inc. The recipient agrees to use it only for the purpose specified and to maintain its confidentiality. No part of this drawing may be reproduced without the prior written permission of Apple Inc. All rights reserved.</small> |
| | AIRPODS |
| <small>THIS DRAWING IS A 3D MODEL GENERATED BY NX</small> | <small>SCALE NONE SHEET 1 OF 1</small> |

41. Revision History

This chapter describes changes to the Accessory Design Guidelines for Apple Devices from the previous revision.

Added Content

- [Device Models](#) (page 36)
- [MagSafe Attach](#) (page 82)
- [MagSafe Case Magnet Array](#) (page 83)
- [MagSafe Accessory Magnet Array](#) (page 89)
- [iPhone 12 Pro Max 1 of 2](#) (page 161)
- [iPhone 12 Pro Max 2 of 2](#) (page 162)
- [iPhone 12 Pro 1 of 2](#) (page 163)
- [iPhone 12 Pro 2 of 2](#) (page 164)
- [iPhone 12 1 of 2](#) (page 165)
- [iPhone 12 2 of 2](#) (page 166)
- [iPhone 12 mini 1 of 2](#) (page 167)
- [iPhone 12 mini 2 of 2](#) (page 168)
- [iPad Air \(4th generation\) 1 of 5](#) (page 188)
- [iPad Air \(4th generation\) 2 of 5](#) (page 189)
- [iPad Air \(4th generation\) 3 of 5](#) (page 190)
- [iPad Air \(4th generation\) 4 of 5](#) (page 191)
- [iPad Air \(4th generation\) 5 of 5](#) (page 192)
- [Apple Watch Series 6, 44 mm](#) (page 258)
- [Apple Watch Series 6, 40 mm](#) (page 259)
- [Apple Watch SE, 44 mm](#) (page 260)
- [Apple Watch SE, 40 mm](#) (page 261)

Updated Content

- [Magnetic Interference](#) (page 19)
- [Near Field Communication \(NFC\)](#) (page 21)
- [Edge Swipe Gestures](#) (page 27)

41. Revision History

41.2 Updated Content

- [Cover Glass Contact](#) (page 28)
- [Wireless Power and Rear Pockets](#) (page 28)
- [Taptic Engine](#) (page 32)
- [Device Models](#) (page 36)
- [Product Design](#) (page 43)
- [Smart Covers](#) (page 49)
- [Strobes](#) (page 59)
- [Direct Power Source](#) (page 76)
- [Fast Charge for iPhone \(18 W\)](#) (page 78)
- [Role and Topology Management](#) (page 130)
- [Link Supervision Timeout](#) (page 132)
- [Connection Parameters](#) (page 144)
- [Data Packet Length Extension](#) (page 144)
- [Providing Power](#) (page 154)
- [iPad \(7th generation\) & iPad \(8th generation\) 1 of 3](#) (page 203)
- [iPad \(7th generation\) & iPad \(8th generation\) 2 of 3](#) (page 204)
- [iPad \(7th generation\) & iPad \(8th generation\) 3 of 3](#) (page 205)



Apple Inc.
Copyright © 2020 Apple Inc.
All rights reserved

Terms and Conditions (“Terms”)

These Guidelines are made available to you for informational purposes only. If you make or distribute any accessory for an Apple device based on or in connection with these Guidelines (“Accessories”), you agree to the following covenants, terms and conditions:

All intellectual property rights in and to the Guidelines, and all technology described therein, are retained by Apple Inc. (“Apple”). You acknowledge and agree that Apple is not granting you, and nothing contained herein shall constitute or be construed or interpreted as a grant, by implication, estoppel or otherwise, of any license, covenant, immunity, release or right under or with respect to any intellectual property rights of Apple, including without limitation any rights to make, use, have made, sell, import, or otherwise relating in any way to any Apple device or technology described in or relating to the Guidelines.

You agree to follow Apple’s Guidelines For Using Apple Trademarks and Copyrights as published on Apple’s website at www.apple.com/legal/guidelinesfor3rdparties.html (“IP Guidelines”) and as may be modified from time to time. You agree not to use the marks “Apple,” the Apple Logo, “Mac,” “iPhone,” “iPod touch,” “iPad,” “Apple Watch,” “WATCH” or any other marks belonging or licensed to Apple in any way except as expressly authorized in writing by Apple in each instance or as permitted in the IP Guidelines. You agree that all goodwill arising out of your authorized use of Apple’s marks shall inure to the benefit of and belong to Apple.

You agree to indemnify, hold harmless, and, at Apple’s option, defend, Apple against any claims, causes of action, losses, liabilities, damages, fines, settlements, costs, fees, and expenses (including attorney and other professional fees and expenses) arising out of: (i) your use of the Guidelines, including without limitation, any claims that any Accessory, or the combination of any Accessory with any software, technology, intellectual property, device, apparatus or assembly not supplied by Apple, infringes any patent, copyright, trade secret or other intellectual property right; (ii) the manufacture, use, promotion, distribution, sale, offer for sale, import, other distribution or exploitation or performance of any product, case, cover, band, charging stand, or other Accessory or product incorporating any Accessory, including any personal injury or product liability claims; or (iii) any failure to comply with any of the Guidelines. You will not, without Apple’s prior written consent, make any admissions of liability, enter into any settlement that imposes any obligation on Apple, or publicize any settlement details relating to Apple. In addition, for any claims related to these Terms where you do not have an indemnification obligation, you shall provide all reasonable assistance to Apple and/or its counsel in connection with the defense, remedy or mitigation of such claims.

Applicable laws or regulations may impose additional restrictions or requirements on Accessories or products that incorporate the Accessories. You represent and warrant that you are in full compliance with all applicable laws, regulations, and policies in the United States and in any other location in which you engage, in whole or in part, in any activity related to the design, manufacture, marketing, sale or offer for sale, use, or other distribution of Accessories or products that incorporate the Accessories. You agree to promptly notify Apple of any complaints or threats of complaints regarding products that incorporate the Accessories with respect to any such regulatory requirements, in which case Apple may limit or terminate your ability to make, sell or purchase additional Accessories.

You expressly acknowledge and agree that access to the Guidelines is at your sole and entire risk and that you are solely responsible and liable for any harm or damage to any Apple product arising out of any breach by you of these covenants, terms and conditions. THE GUIDELINES ARE PROVIDED “AS IS” AND WITHOUT REPRESENTATION, WARRANTY, UPGRADES OR SUPPORT OF ANY KIND. APPLE AND APPLE’S DISTRIBUTORS, AFFILIATES, LICENSOR(S) AND SUPPLIER(S) (“APPLE PARTIES”) EXPRESSLY DISCLAIM ALL REPRESENTATIONS, WARRANTIES AND CONDITIONS, EXPRESS OR IMPLIED, INCLUDING THE IMPLIED WARRANTIES AND CONDITIONS OF MERCHANTABILITY, OF SATISFACTORY QUALITY, OF FITNESS FOR A PARTICULAR PURPOSE, OF NON-INFRINGEMENT AND OF ACCURACY. NONE OF THE APPLE PARTIES WARRANTS THAT THE GUIDELINES OR ANY ACCESSORY WILL MEET YOUR REQUIREMENTS, THAT DEFECTS IN THEM WILL BE CORRECTED OR THAT THEY WILL BE COMPATIBLE WITH FUTURE APPLE PRODUCTS. NO ORAL OR WRITTEN INFORMATION OR ADVICE GIVEN BY ANY APPLE PARTY OR AN APPLE AUTHORIZED REPRESENTATIVE WILL CREATE A WARRANTY.

EXCEPT TO THE EXTENT SUCH A LIMITATION IS PROHIBITED BY LAW, IN NO EVENT WILL ANY APPLE PARTY BE LIABLE FOR ANY INCIDENTAL, SPECIAL, INDIRECT, CONSEQUENTIAL, EXEMPLARY OR PUNITIVE DAMAGES, INCLUDING LOST PROFITS, LOST REVENUES OR BUSINESS INTERRUPTIONS, ARISING OUT OF OR RELATING TO THE GUIDELINES UNDER A THEORY OF CONTRACT, WARRANTY, TORT (INCLUDING NEGLIGENCE), PRODUCTS LIABILITY OR OTHERWISE, EVEN IF ANY APPLE PARTY HAS BEEN ADVISED OF THE POSSIBILITY OF SUCH DAMAGES, AND NOTWITHSTANDING THE FAILURE OF ESSENTIAL PURPOSE OF ANY REMEDY. IN NO EVENT WILL THE APPLE PARTIES’ TOTAL LIABILITY TO YOU FOR ALL DAMAGES AND CLAIMS UNDER OR RELATED TO THE GUIDELINES EXCEED THE AMOUNT OF US\$50.00.

These Terms will be governed by and construed and enforced under the laws of the United States and the State of Delaware, except that the arbitration clause and any arbitration hereunder shall be governed by the Federal Arbitration Act, Chapters 1 and 2. The United Nations Convention on Contracts for the International Sale of Goods shall not apply to these Terms. All disputes arising out of or in connection with these Terms shall be finally settled under the Rules of Arbitration of the International Chamber of Commerce by one arbitrator appointed in accordance with such rules, and shall be conducted according to the International Bar Association Rules on the Taking of Evidence in International Arbitration. The arbitration shall take place in San Francisco, California. The arbitration shall be conducted in English. The award shall be rendered within six months of the commencement of the arbitration, unless the arbitrator determines that the interest of justice requires that such limit be extended.