

F0-04THM 4-CHANNEL THERMOCOUPLE INPUT



In This Chapter...

Module Specifications	15-2
Connecting and Disconnecting the Field Wiring	15-4
Module Operation	15-7
Special V-memory Locations	15-8
Configuring the Module in Your Control Program	15-12
Negative Temperature Readings with Magnitude Plus Sign	15-16
Module Resolution.....	15-18
Analog Input Ladder Logic Filter	15-19
Thermocouple Burnout Detection Bits	15-21

Module Specifications

The F0-04THM 4-Channel Thermocouple Input Module provides the following features and benefits:

- Four thermocouple input channels with 16-bit voltage resolution or 0.1 °C/°F temperature resolution.
- Automatically converts type E, J, K, R, S, T, B, N, or C thermocouple signals into direct temperature readings. No extra scaling or complex conversion is required.
- Temperature data can be expressed in °F or °C.
- Module can be configured as 0–39.0625 mVDC, ±39.0625 mVDC, ±78.125 mVDC, 0–156.25 mV, ±156.25 mVDC and 0–1.25 VDC input and will convert volts and millivolt signal levels into 16-bit digital (0–65535) values.
- Signal processing features include automatic cold junction compensation (CJC), thermocouple linearization, and digital filtering.
- The temperature calculation and linearization are based on data provided by the National Institute of Standards and Technology (NIST).
- Diagnostic features include detection of thermocouple burnout or disconnection.

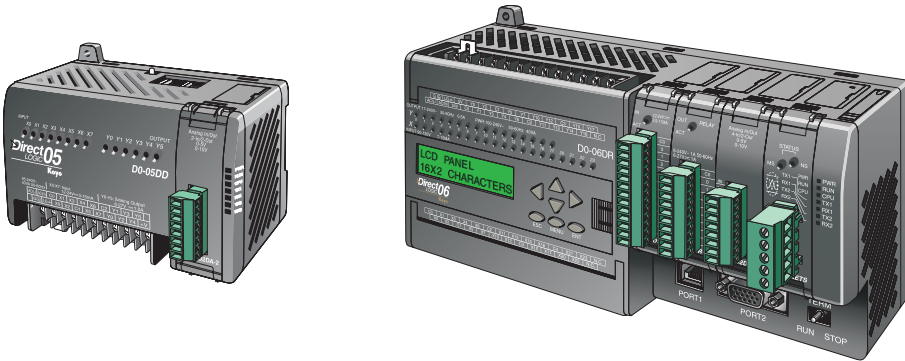

NOTE: The DL05 CPU's analog feature for this module requires **DirectSOFT32** Version 3.0c (or later) and firmware version 4.60 (or later). The DL06 requires **DirectSOFT32** version V4.0, build 16 (or later) and firmware version 1.40 (or later). See our website for more information: www.automationdirect.com.

The following tables provide the specifications for the F0-04THM Analog Input Module. Review these specifications to make sure the module meets your application requirements.

General Specifications	
Number of Channels	4, differential inputs, voltage or thermocouple
Common Mode Range	-1.3 VDC to +3.8 VDC
Conversion Time	270ms / channel
Common Mode Rejection	> 100dB @ 50/60Hz.
Input Impedance	5MΩ min.
Absolute Maximum Ratings	Fault-protected inputs to ±50VDC
Accuracy vs. Temperature	±15ppm / °C maximum (Full scale);
Max. full scale error (including offset)	±35ppm / °C maximum (0–1.25 V)
PLC Update Rate	4 channels per scan
Power Budget Requirement	30mA @ 5VDC (supplied by base)
Operating Temperature	0 to 60°C (32 to 140°F)
Storage Temperature	-20 to 70°C (-4 to 158°F)
Relative Humidity	5 to 95% (non-condensing)
Environmental Air	No corrosive gases permitted
Vibration	MIL STD 810C 514.2
Shock	MIL STD 810C 516.2
Noise Immunity	NEMA ICS3-304
Replacement Terminal Block	F0-IOCON-THM (comes with CJC)
Wire Size Range & Connector Screw Torque	22–16 AWG; 1.7 inch-pounds (0.192 N-m); TW-SD-VSL-1 Screwdriver Recommended
Thermocouple Specifications	
Input Ranges	Type J -190 to 760 °C (-310 to 1400 °F) Type K -150 to 1372 °C (-238 to 2502 °F) Type E -210 to 1000 °C (-346 to 1832 °F) Type R 65 to 1768 °C (149 to 3214 °F) Type S 65 to 1768 °C (149 to 3214 °F) Type T -230 to 400 °C (-382 to 752 °F) Type B 529 to 1820 °C (984 to 3308 °F) Type N -70 to 1300 °C (-94 to 2372 °F) Type C 65 to 2320 °C (149 to 4208 °F)
Display Resolution	±0.1 °C or ±0.1 °F
Cold Junction Compensation	Automatic
Warm-Up Time	30 minutes typically ± 1°C repeatability
Linearity Error (End to End)	±1°C maximum, ±0.5 °C typical
Maximum Inaccuracy	±3°C (excluding thermocouple error)
Voltage Input Specifications	
Voltage Ranges	0-39.0625 mVDC, ±39.0625 mVDC, ±78.125 mVDC, 0-156.25 mVDC, ±156.25 mVDC, 0-1.25 VDC
Resolution	16 bit (1 in 65535)
Max. Offset Error (All Input Ranges)	0.05% @ 0-60 °C; Typical: 0.04% @ 25 °C
Linearity Error (All Input Ranges)	0.05% @ 0-60 °C; Typical: 0.03% @ 25 °C
Maximum Inaccuracy	0-39.0625 mVDC, ±39.0625 mVDC, ±78.125 mVDC ranges: 0.1% @ 0-60°C; Typical: 0.04% @ 25°C 0-156.25 mVDC, ±156.25 mVDC, 0-1.25 VDC ranges: 0.05% @ 0-60°C; Typical: 0.04% @ 25°C
All percentages are calculated as a percent of 2 ¹⁶ (65536) counts. (0.025% max error => 0.025 * 65536/100 = 16 counts max error)	

Connecting and Disconnecting the Field Wiring

Wiring Guidelines

Your company may have guidelines for wiring and cable installation. If so, you should check those before you begin the installation. Here are some general things to consider:

- Use the shortest wiring route whenever possible.
- Use shielded wiring and ground the shield at the PLC power source. *Do not* ground the shield at both the transmitter and the PLC power source.
- Use thermocouple extension wire that is the same as the thermocouple type when extending the length.
- Do not run the signal wiring next to large motors, high current switches, or transformers. This may cause noise problems.
- Route the wiring through an approved cable housing to minimize the risk of accidental damage. Check local and national codes to choose the correct method for your application.

To remove the terminal block, disconnect power to the PLC and the field devices. Pull the terminal block firmly until the connector separates from the module.

You can remove the thermocouple module from the PLC by folding out the retaining tabs at the top and bottom of the module. As the retaining tabs pivot upward and outward, the module's connector is lifted out of the PLC socket. Once the connector is free, you can lift the module out of its slot.

Use the following diagram to connect the field wiring. If necessary, the F0-04THM terminal block can be removed to make removal of the module possible without disturbing field wiring.

Thermocouple Input Wiring Diagram

All of the module's CH- terminals **must** be connected together. This will help eliminate ground potential differences between the input channels that could cause damage to the module. The two unlabeled terminals are internally connected and may be used for convenience to connect the CH- terminals together as shown below.

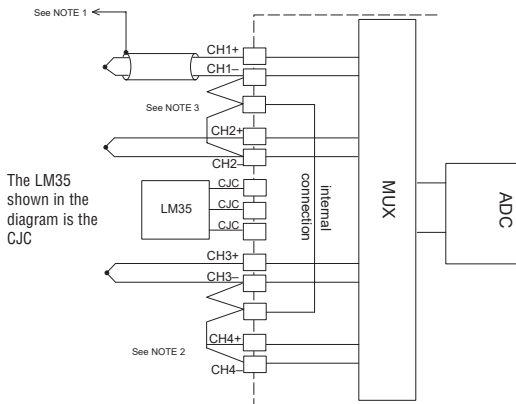

Notes:

1. Shields should be grounded at the PLC power source only.
2. Unused channels should have a shorting wire (jumper) installed from CH+ to CH-.
3. All CH- terminals must be connected together.
4. This module is not compatible with the ZIPLink wiring system.

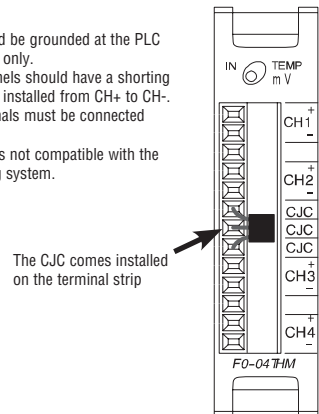

Thermocouples

Use shielded thermocouples whenever possible to minimize the presence of noise on the thermocouple wire. Ground the shield wire at one end only. For both grounded and ungrounded thermocouples, connect the shield to the 0V (common) terminal of the PLC power supply.

Grounded Thermocouple Assembly

A grounded thermocouple provides better response time than an ungrounded thermocouple because the tip of the thermocouple junction is in direct contact with the protective case.

Ungrounded Thermocouple Assembly

An ungrounded thermocouple is electrically isolated from the protective case. If the case is electrically grounded it provides a low-impedance path for electrical noise to travel. The ungrounded thermocouple provides a more stable and accurate measurement in a noisy environment. To avoid exceeding the common mode specifications, be sure that the machine assembly is properly bonded together.

Exposed Grounded Thermocouple

The thermocouple does not have a protective case and is directly connected to a device with a higher potential. Grounding the thermocouple assures that the thermocouple remains within the common mode specifications. Because a thermocouple is essentially a wire, it provides a low-impedance path for electrical noise. The noise filter has a response of $>100\text{dB}$ @ 50/60 Hz.



WARNING: A thermocouple can become shorted to a high voltage potential. Because common terminals are internally connected together, whatever voltage potential exists on one thermocouple will exist on the other channels.

Ambient Variations in Temperature

The F0-04THM module has been designed to operate within the ambient temperature range of 0°C to 60°C.

The cold junction compensation is calibrated to operate in a still-air environment. If the module is used in an application that has forced convection cooling, an error of 2–3 °C may be introduced. To compensate for this you can use ladder logic to correct the values.

When configuring the system design it is best to locate any heat-producing devices above and away from the PLC chassis because the heat will affect the temperature readings. For example, heat introduced at one end of the terminal block can cause a channel-to-channel variation.

When exposing the F0-04THM module to abrupt ambient temperature changes it will take several minutes for the cold junction compensation and terminal block to stabilize. Errors introduced by abrupt ambient temperature changes will be less than 4°C.

Module Operation

Channel Scanning Sequence

The DL05 and DL06 read the data from all four input channels during each scan. The CPUs support special V-memory locations that are used to manage the data transfer. This is discussed in more detail on the following page, “Special V-memory Locations”.

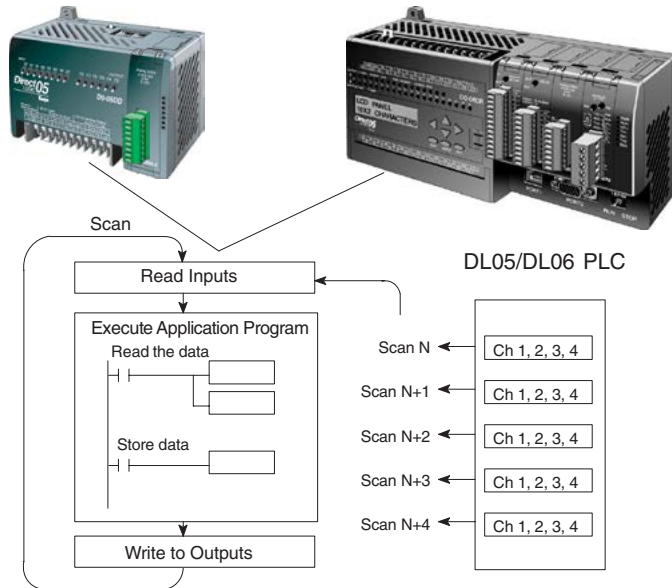

Analog Module Update

Even though the channel updates to the CPU are synchronous with the CPU scan, the module asynchronously monitors the analog transmitter signal and converts the signal to a 16-bit binary representation. This enables the module to continuously provide accurate measurements without slowing down the discrete control logic in the RLL program.

The time required to sense the temperature and copy the value to V-memory is 270 milliseconds minimum to 1080 milliseconds plus 1 scan time maximum (number of channels x 270 milliseconds + 1 scan time).

Special V-memory Locations

The DL05 and DL06 PLCs have special V-memory locations assigned to their respective option slots. These V-memory locations allow you to:

- Specify the number of input channels enabled and BCD/Binary data format
- Specify the input pointer address
- Specify the thermocouple or voltage input type
- Specify the units code – temperature scale and data format
- Enable/disable thermocouple burnout detection
- Specify burnout data value at burnout
- Read module setup diagnostics

Module Configuration Registers

The table below shows the special V-memory locations used by the DL05 and DL06 PLCs for the F0-04THM module.

Module Configuration Parameters	DL05 and DL06 Option Slot				
	DL05 Slot	DL06 Slot 1	DL06 Slot 2	DL06 Slot 3	DL06 Slot 4
A: Number of Channels Enabled / Data Format	V7700	V700	V710	V720	V730
B: Input Pointer	V7701	V701	V711	V721	V731
C: Input Type	V7703	V703	V713	V723	V733
D: Units Code	V7704	V704	V714	V724	V734
E: Thermocouple Burnout Detection Enable	V7705	V705	V715	V725	V735
F: Thermocouple Burnout Data Value	V7706	V706	V716	V726	V736
G: Diagnostic Error	V7707	V707	V717	V727	V737

A: Number of Channels Enabled/Data Format Register

This V-memory location is used to define the number of input channels to be enabled and to set the channel data to BCD or binary format.

Number of Channels Enabled	Channel Data in BCD Format	Channel Data in Binary Format
1 Channel	K100	K8100
2 Channels	K200	K8200
3 Channels	K300	K8300
4 Channels	K400	K8400

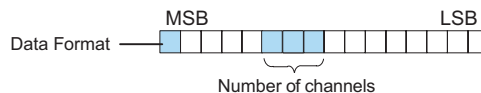

B: Input Pointer Register

This is a system parameter that points to a V-memory location used for storing module channel input data. The V-memory location loaded in the input pointer V-memory location is an octal number identifying the first V-memory location for the input data. This V-memory location is user defined, but must use available consecutive V-memory locations. For example, loading O2000 causes the pointer to write Ch 1's data value to V2000/2001, Ch 2's data value to V2002/2003, CH 3's data value to V2004/2005 and Ch 4's data value to V2006/2007.



NOTE: Each channel's data value occupies two (2) consecutive V-memory locations. This allows for more than four (4) digits to be displayed if a BCD format for channel data is selected. For example: 1234.5 °F. A binary format for either a 15-bit magnitude plus sign or 16-bit 2's complement value will occupy the first V-memory location of the two V-memory locations assigned for the selected channel. Refer to the specific PLC's user manual being used for available user V-memory locations.

C: Input Type Selection Register

This V-memory register must be set to match the type of thermocouple being used or the input voltage level. Use the table to determine your settings.

Thermocouple/ Voltage Input Type	Input Selection	Temperature Range °C	Temperature Range °F
J	K0	-190 to 760	-310 to 1400
K	K1	-150 to 1372	-238 to 2502
E	K2	-210 to 1000	-346 to 1832
R	K3	65 to 1768	149 to 3214
S	K4	65 to 1768	149 to 3214
T	K5	-230 to 400	-382 to 752
B	K6	529 to 1820	984 to 3308
N	K7	-70 to 1300	-94 to 2372
C	K8	65 to 2320	149 to 4208
0-39.0625 mVDC	K9	N/A	N/A
±39.0625 mVDC	KA	N/A	N/A
±78.125 mVDC	KB	N/A	N/A
0-156.25 mVDC	KC	N/A	N/A
±156.25 mVDC	KD	N/A	N/A
0-1.25 VDC	KE	N/A	N/A

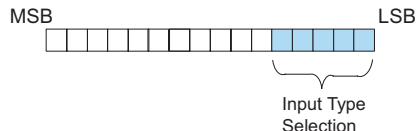

NOTE: The **CJC** functionality is automatically disabled when a Voltage input is selected.

D: Units Code Register

All thermocouple types are converted into a direct temperature reading in either Fahrenheit or Celsius. The data contains one implied decimal place. For example, a value in V-memory of 1002 would be 100.2 °C or °F.

For thermocouple ranges which include negative temperatures (J,E,K,T,N), the display resolution is from -3276.7 to +3276.7. For positive-only thermocouple ranges (R,S,B,C), the display resolution is 0 to 6553.5.

Negative temperatures can be represented in either 2's complement or magnitude plus sign form. If the temperature is negative, the most significant bit in the V-memory location is set.

The 2's complement data format may be required to correctly display bipolar data on some operator interfaces. This data format could also be used to simplify averaging a bipolar signal. To view this data format in *DirectSoft32*, select Signed Decimal.

For unipolar thermocouple ranges (R,S,B,C), it does not matter if magnitude plus sign or 2's complement is selected.

The bipolar voltage input ranges may be converted to a 15-bit magnitude plus sign or a 16-bit 2's complement value.

Bit 0 = Temperature Scale
(ignored if Voltage input is selected)

- 0 = Temp in degrees F
- 1 = Temp in degrees C

Bit 1 = Data Format
0 = Magnitude plus sign bit format
1 = 2's Complement format

Unit Code Register - Truth Table				
Temperature Scale	Data Format	Bit 1	Bit 0	Value
°F	Magnitude + sign bit	0	0	K0
°C	Magnitude + sign bit	0	1	K1
°F	2's Complement	1	0	K2
°C	2's Complement	1	1	K3

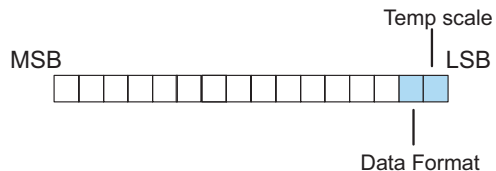

E: Thermocouple Burnout Detection Enable Register

This register is used to enable/disable the thermocouple burnout function. Be sure to disable the burnout detection function when checking the module calibration.

Bit 0 = Thermocouple Burnout Detection Enable/Disable

- 0 = Burnout detection is enabled
- 1 = Burnout detection is disabled

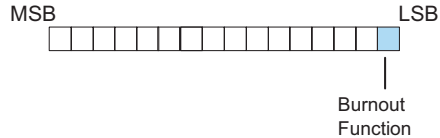

F: Thermocouple Burnout Data Value Register

This register is used to define either up scale or down scale channel values when a channel thermocouple burnout occurs.

Bit 0 = Up scale/down scale value at Burnout

0 = Up scale value at Burnout:

Unipolar input type: FFFFh (BCD/HEX) or 65535 (Binary)
written to CH register

Bipolar input type: 7FFFh (BCD/HEX) or 32767 (Binary)
written to CH register

1 = Down scale value at Burnout:

0000h (BCD/HEX) or 0 (Binary) written to CH register

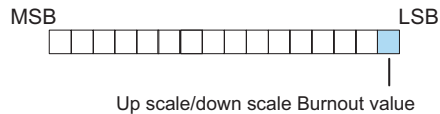

G: Diagnostics Error Register

This register is used to determine whether the configuration of the module is valid or not. It is controlled by the PLC and is read only.

Bit 0 = Diagnostic bit:

- 0 = Module setup is valid
- 1 = Module setup is not valid

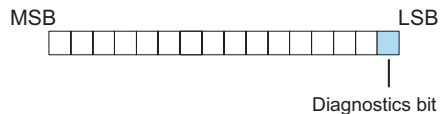

Configuring the Module in Your Control Program

DL05 Example 1

The example program below shows how to setup the F0-04THM for 4 input channels enabled, J type thermocouple on all 4 input channels, BCD channel data format, Fahrenheit (°F) temperature scale, magnitude plus sign bit format, and burnout detection enabled with an up scale burnout specified. Place this rung anywhere in the ladder program or in the initial stage if you are using stage programming instructions.

This is all that is required to read the temperature or voltage input data into V-memory locations. Once the data is in V-memory you can perform mathematical calculations with the data, compare the data against preset values, etc. V2000 is used in the example but you can use any user V-memory location.

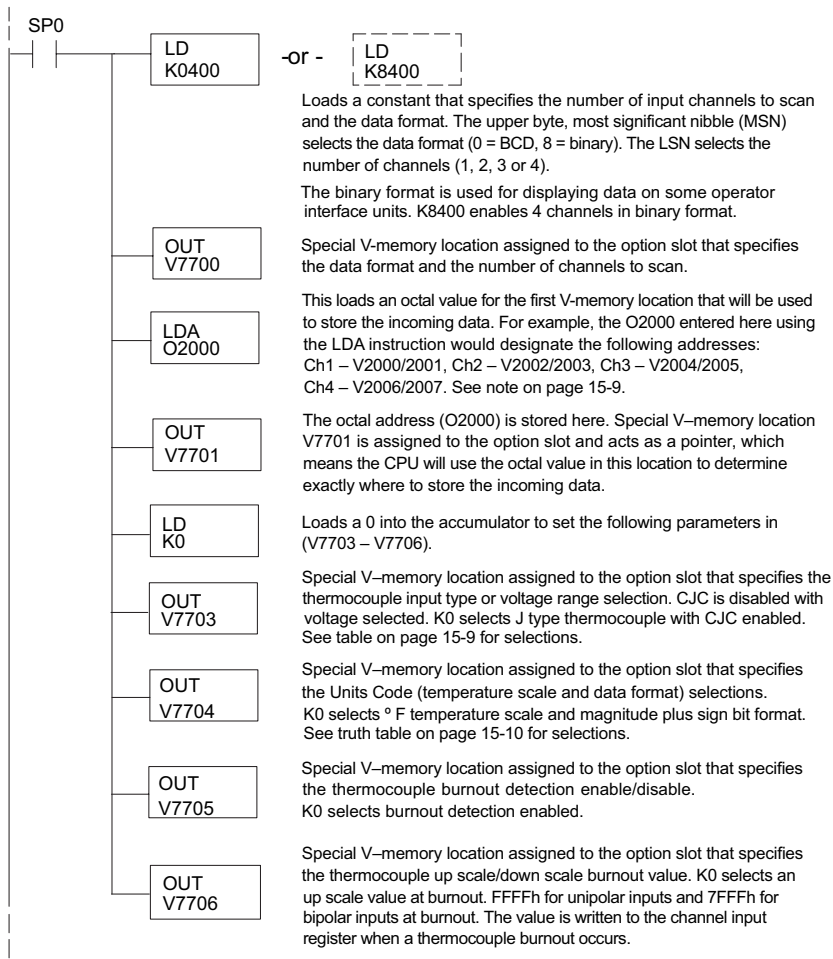

DL05 Example 2

The example program below shows how to setup the F0-04THM for 2 input channels enabled, use of a K type thermocouple on the first 2 input channels, BCD channel data format, Celsius (°C) temperature scale, 2's complement format, and burnout detection enabled with a down scale burnout specified. Again, place this rung in the ladder program or in the initial stage if you are using stage programming instructions.

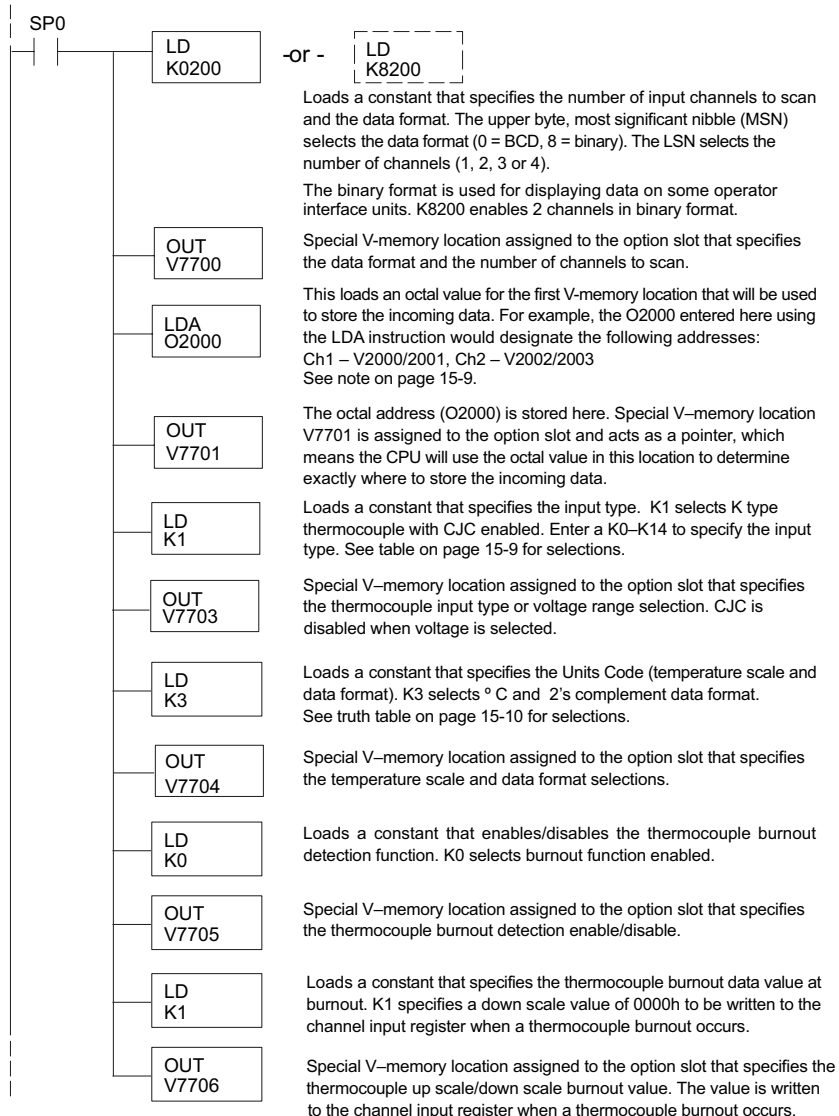

DL06 Example 1

The example program below shows how to setup the F0-04THM in option slot 1 for 4 input channels enabled, use of a J type thermocouple on all 4 input channels, BCD channel data format, Fahrenheit (°F) temperature scale and magnitude plus sign bit format, and burnout detection enabled with an up scale burnout specified. Use the table shown on page 15-8 to determine the pointer values if locating the module in any of the other slots. Place this rung anywhere in the ladder program or in the initial stage if you are using stage programming instructions.

This is all that is required to read the temperature or voltage input data into V-memory locations. Once the data is in V-memory you can perform mathematical calculations with the data, compare the data against preset values, etc. V2000 is used in the example but you can use any user V-memory location.

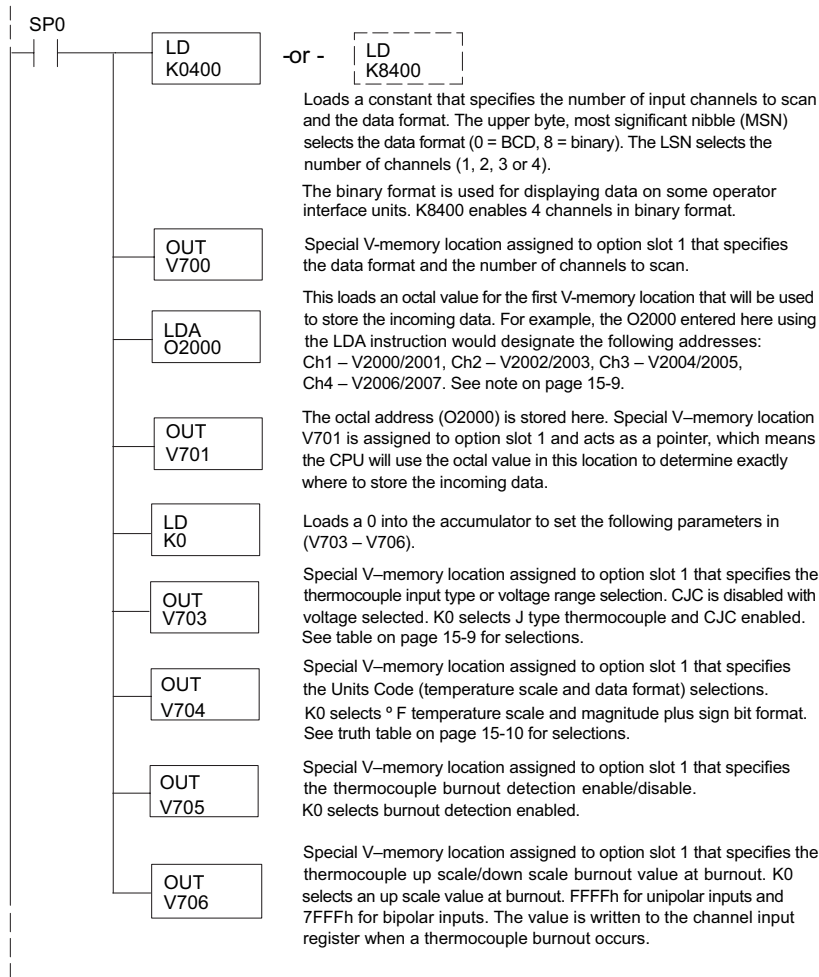

DL06 Example 2

The example program below shows how to setup the F0-04THM in option slot 2 for 2 input channels enabled, use of a K type thermocouple on the first 2 input channels, BCD channel data format, Celsius (°C) temperature scale, 2's complement format, and burnout detection enabled with a down scale burnout specified. Use the table shown on page 15-8 to determine the pointer values if locating the module in any of the other slots. V-memory location V3000 is shown in the example, but you can use any available user V-memory location. Again, place this rung anywhere in the ladder program or in the initial stage if you are using stage programming instructions.

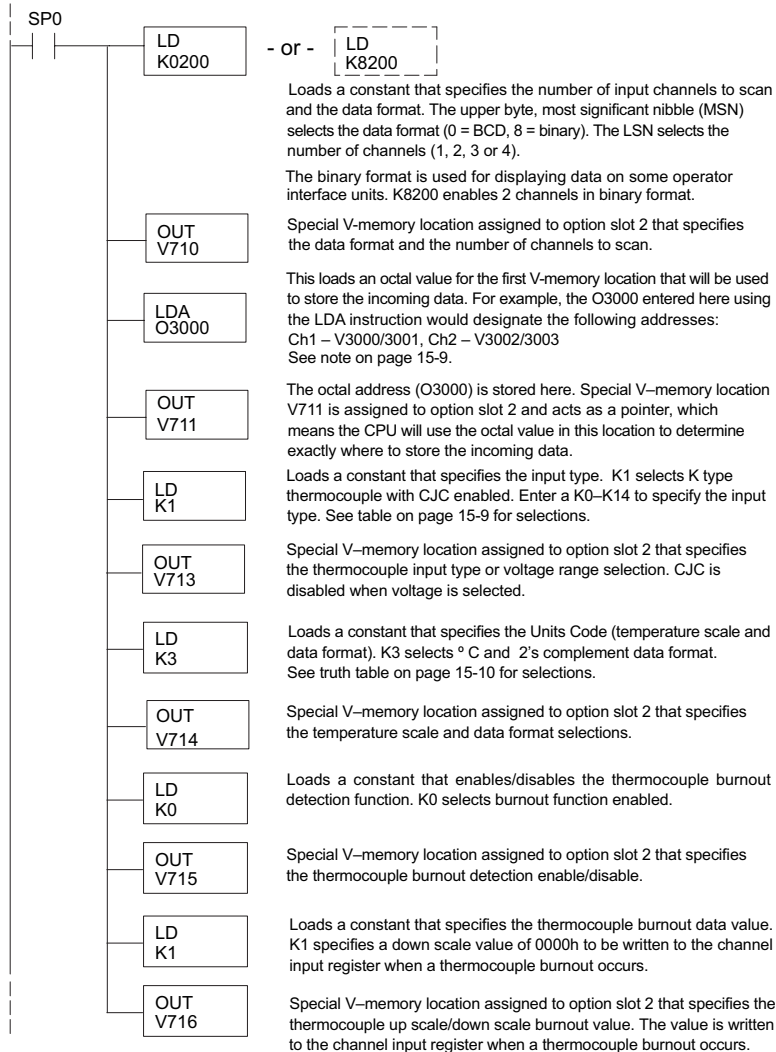

Negative Temperature Readings with Magnitude Plus Sign

With bipolar ranges, you need some additional logic to determine whether the value being returned represents a positive temperature/voltage or a negative temperature/voltage. There is a simple solution:

- If you are using bipolar ranges and you get a value greater than or equal to 8000h, the value is negative.
- If you get a value less than or equal to 7FFFh, the value is positive.

The sign bit is the most significant bit, which combines 8000h to the data value. If the value is greater than or equal to 8000h, you only have to mask the most significant bit and the active channel bits to determine the actual data value.

The following two programs show how you can accomplish this. The first example uses magnitude plus sign (binary) and the second example uses magnitude plus sign (BCD).

Since you always want to know when a value is negative, these rungs should be placed before any other operations that use the data, such as math instructions, scaling operations, and so forth. Also, if you are using stage programming instructions, these rungs should be in a stage that is always active. Note: you only need this logic for each channel that is using bipolar input signals. The examples only show two channels.

Magnitude Plus Sign (Binary)

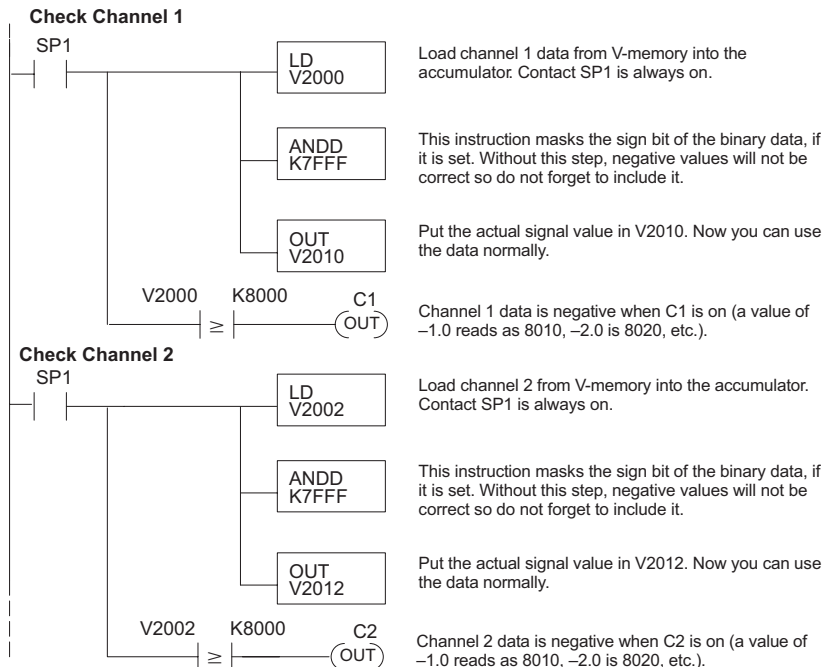

Magnitude Plus Sign (BCD)

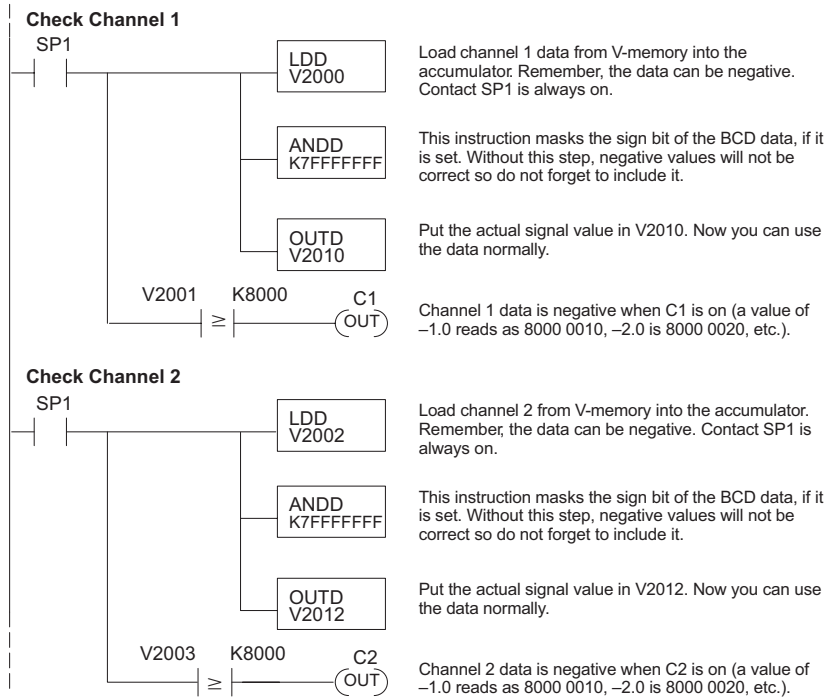

Module Resolution

Module Resolution 16-Bit (Unipolar Voltage Input)

Unipolar analog signals are converted into 65536 (2^{16}) counts ranging from 0 to 65535. For example, with a 0 to 156.25 mVDC signal range, 78 mVDC would be 32767. A value of 65535 represents the upper limit of the range.

$$\text{Unipolar Resolution} = \frac{H - L}{65535}$$

H or L = high or low limit of the range

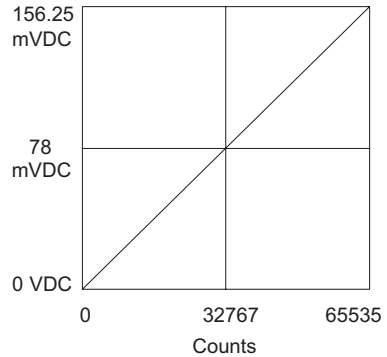

Module Resolution 15-Bit Plus Sign (Bipolar Voltage Input)

The module has 16-bit unipolar or 15-bit + sign bipolar resolution. Bipolar analog signals are converted into 32768 (2^{15}) counts ranging from 0 to 32767. For example, with a -156.25 mVDC to 156.25 mVDC input signal range, 156.25 mVDC would be 32767. The bipolar ranges utilize a sign bit to provide 16-bit resolution. A value of 32767 can represent the upper limit of either side of the range. Use the sign bit to determine negative values.

$$\text{Bipolar Resolution} = \frac{H - L}{32767}$$

H or L = high or low limit of the range

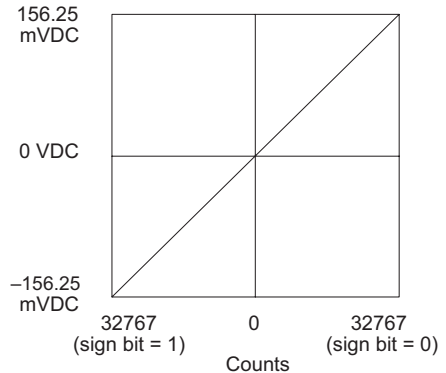

Analog Input Ladder Logic Filter

PID Loops / Filtering

Please refer to the “PID Loop Operation” chapter in the DL06 or DL05 User Manual for information on the built-in PV filter (DL05/06) and the ladder logic filter (DL06 only) shown below. A filter must be used to smooth the analog input value when auto tuning PID loops to prevent giving a false indication of loop characteristics.

Smoothing the Input Signal (DL06 only)

The filter logic can also be used in the same way to smooth the analog input signal to help stabilize PID loop operation or to stabilize the analog input signal value for use with an operator interface display, etc.



WARNING: The built-in and logic filters are not intended to smooth or filter noise generated by improper field device wiring or grounding. Small amounts of electrical noise can cause the input signal to bounce considerably. Proper field device wiring and grounding must be done before attempting to use the filters to smooth the analog input signal.

Using Binary Data Format

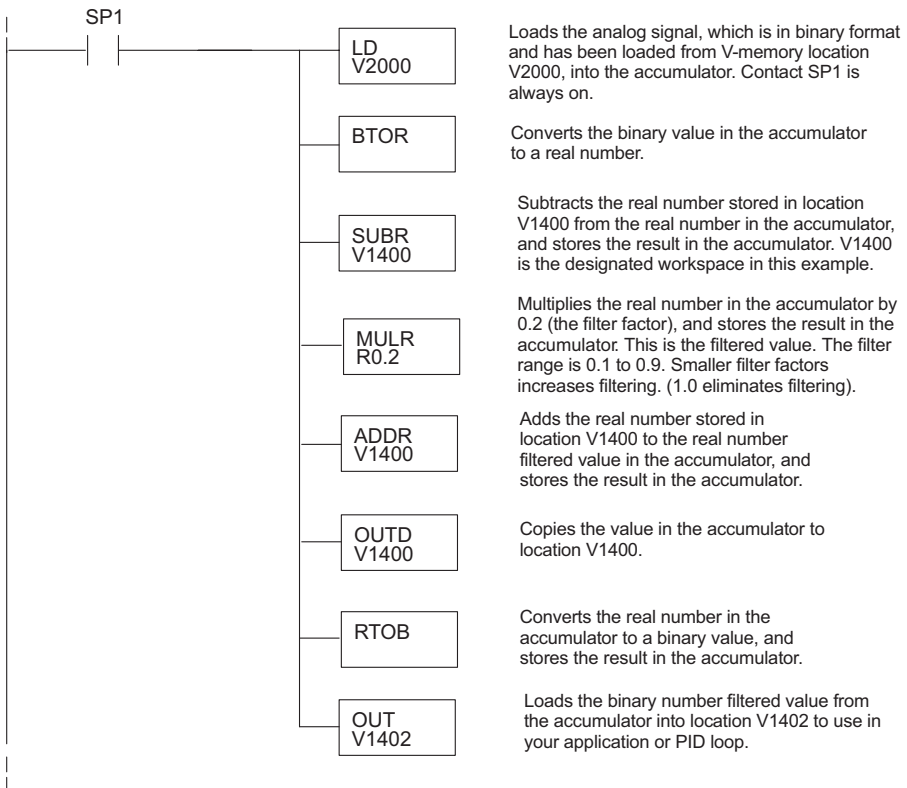



NOTE: Be careful not to do a multiple number conversion on a value. For example, if you are using the pointer method in BCD format to get the analog value, it must be converted to binary (BIN) as shown below. If you are using the pointer method in Binary format, the conversion to binary (BIN) instruction is not needed.

Using BCD Data Format

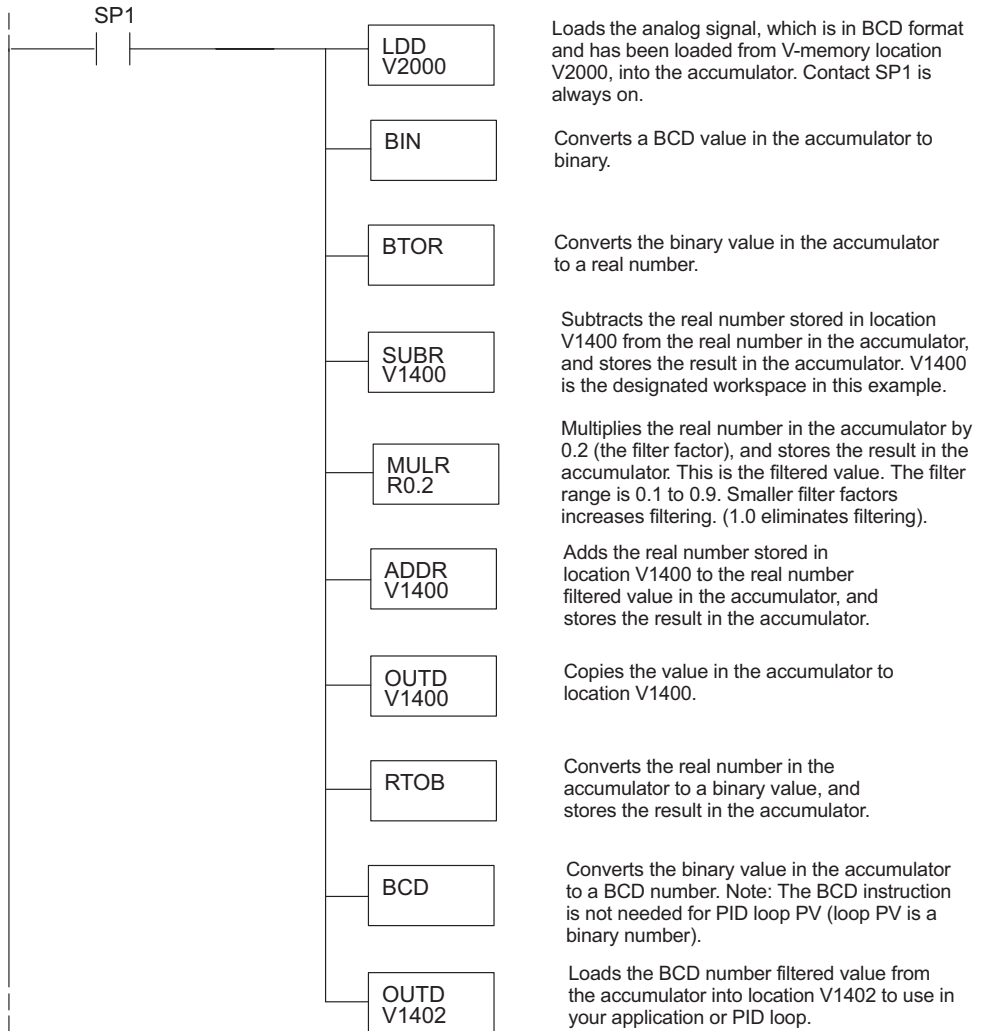

Thermocouple Burnout Detection Bits

Special Relays Corresponding to Thermocouple Burnouts

The following Special Relay (SP) bits can be used in your program to monitor for thermocouple burnout.

SP bit :

0 = Thermocouple OK

1 = Thermocouple burnout

Module Channel	DL05 and DL06 Option Slot				
	DL05 Slot	DL06 Slot 1	DL06 Slot 2	DL06 Slot 3	DL06 Slot 4
Channel 1	SP600	SP140	SP240	SP340	SP440
Channel 2	SP601	SP141	SP241	SP341	SP441
Channel 3	SP602	SP142	SP242	SP342	SP442
Channel 4	SP603	SP143	SP243	SP343	SP443