



POWERLAB[®]
TEACHING SERIES

Owner's Guide



ADINSTRUMENTS
making science easier

This document was, as far as possible, accurate at the time of release. However, changes may have been made to the software and hardware it describes since then. ADInstruments Pty Ltd reserves the right to alter specifications as required. Late-breaking information may be supplied separately.

Trademarks of ADInstruments

PowerLab®, LabChart®, LabTutor®, Lt®, LabAuthor® and MacLab® are registered trademarks of ADInstruments Pty Ltd. The names of specific recording units, such as PowerLab 8/35, are trademarks of ADInstruments Pty Ltd. LabTutor Server, Chart and Scope (application programs) and LabTutor Online are trademarks of ADInstruments Pty Ltd.

Other Trademarks

Apple, Mac and Macintosh are registered trademarks of Apple Computer, Inc.

Windows, Windows 7, Windows 8, Windows 10 and Windows Vista are either registered trademarks or trademarks of Microsoft Corporation.

All other trademarks are the property of their respective owners.

Document Number: U-PL26T/OG-A. Date of issue: 11/18

Copyright © ADInstruments Pty Ltd, 2000 - 2020. All rights reserved. PowerLab, MacLab, LabChart, LabTutor, Lt and LabAuthor are registered trademarks of ADInstruments Pty Ltd. Chart and Scope (application programs), LabTutor Server and LabTutor Online are trademarks of ADInstruments Pty Ltd. The names of specific recording units, such as PowerLab 16/35, are trademarks of ADInstruments Pty Ltd. Windows 8, Windows 7, Windows 10, Windows Vista and .NET Framework are trademarks of Microsoft Corporation. Apple, the Apple logo, MacOS, and Macintosh are trademarks of Apple Computer Inc. registered in the U.S. and other countries. Acrobat and Adobe are registered trademarks of Adobe Systems Incorporated. Igor is a trademark of Wavemetrics Inc. MATLAB is a registered trademark of The MathWorks Inc. Grass is a trademark of Astro-Med Inc. All other trademarks are the property of their respective owners.

Web: www.adinstruments.com

Manufactured in Australia by: ADInstruments (Sydney) Pty. Ltd., 13/22 Lexington Drive
Bella Vista 2153 New South Wales

Technical Support: support.au@adinstruments.com

Documentation: documentation@adinstruments.com

ADInstruments Pty Ltd. ISO 9001:2008 Certified Quality Management System

Reg. No. 1053



Contents

1	Safety Notes	1
	Statement of Intended Use	1
	Safety and Quality Standards	1
	General Safety Instructions	3
	Bio Amp Safety Instructions	4
	Isolated Stimulator Safety Instructions	5
	Cleaning and Sterilization	6
	Inspection and Maintenance	6
	Environment	6
	Transport and Storage Conditions	6
	Operating Conditions	6
	Disposal	6
2	Overview	7
	How to Use This Guide	8
	Software Installation	8
	PowerLab Check	8
	The PowerLab	9
	The Front Panel	9
	Analog Output	11
	Analog Inputs	11
	Isolated Stimulator	12
	The Bio Amp Inputs (Inputs 3 and 4)	12
	The Rear Panel	13
	Audio Connector	14
	I ² C Connector	14
	USB Connector	14
	Digital Input and Output Connectors	14
	Ground Connector	15
	Power Connector	15
	Checking and replacing fuses	15
	The Bio Amp Cable	16
	Supplied Accessories	17
	Other ADInstruments Hardware	18

3	Setting Up	19
	The PowerLab Self-test	20
	Connecting the PowerLab	21
	ADInstruments Software.....	21
	Lt Software	21
	LabChart Software	21
	The Isolated Stimulator	22
	Choosing How Stimulation Should Start	22
	The Bio Amp	25
	Signal Display	25
	Setting the Range.....	26
	Filtering.....	26
4	Technical Aspects and Specifications	28
	How it Works	29
	The Analog Inputs	30
	The Analog Outputs	30
	The External Trigger	31
	Bio Amp Input (Inputs 3 & 4)	32
	The Isolated Stimulator Output.....	33
	PowerLab Accuracy	34
	Connectors.....	34
	Digital Input and Output	34
	I ² C Expansion Connector	35
	Input Connectors.....	36
	USB Connection.....	36
	Earthing and Ground Loop Noise	37
	Specifications	38
	Electromagnetic Compatibility.....	45
5	Troubleshooting	46
	Problems.....	46
	PowerLab LED Error Sequences.....	49
6	Glossary	51



Chapter 1

Safety Notes

Statement of Intended Use

All products manufactured by ADInstruments are intended for use in teaching and research applications and environments only. ADInstruments products are NOT intended to be used as medical devices or in medical environments. That is, no product supplied by ADInstruments is intended to be used to diagnose, treat or monitor a subject. Furthermore no product is intended for the prevention, curing or alleviation of disease, injury or handicap. ADInstruments products are intended to be installed, used and operated under the supervision of an appropriately qualified life-science researcher. The typical usage environment is a research or teaching lab or hospital. ADInstruments equipment is not intended for use in domestic environments.

Where a product meets IEC 60601-1 it is under the principle that:

- this is a more rigorous standard than other standards that could be chosen.
- it provides a high safety level for subjects and operators.

The choice to meet IEC 60601-1 is in no way to be interpreted to mean that a product:

- is a medical device,
- may be interpreted as a medical device, or
- is safe to be used as a medical device.

Safety and Quality Standards

In accordance with European standards PowerLab systems also comply with the electromagnetic compatibility requirements under EN61326-1, which encompasses the EMC directive.

Quality Management System ISO 9001:2008

ADInstruments manufactures products under a quality system certified as complying with ISO 9001:2008 by an accredited certification body.

Regulatory Symbols

Devices manufactured by ADInstruments that are designed for direct connection to humans and animals are tested to IEC60601-1:1998 and IEC60601-1:2005 (including amendments 1 and 2) and EN61326-1:2006, and carry one or more of the safety symbols below. These symbols appear next to those inputs and output connectors that can be directly connected to human subjects.



B (body protected) symbol. Equipment marked with this symbol is suitable for connection to humans and animals provided there is not direct electrical connection to the heart and provides basic protection against electric shock.



BF (body protected- floating) symbol. This means that the input connectors are suitable for connection to humans and animals provided there is no direct electrical connection to the heart and provides increased protection against electric shock over B rated applied parts.



Warning symbol. The exclamation mark inside a triangle means that the supplied documentation must be consulted for operating, cautionary or safety information before using the device.



CE Mark. All front-end amplifiers and PowerLab systems carry the CE mark and meet the appropriate EU directives.



Refer to booklet symbol. This symbol specifies that the user needs to refer to the Instruction manual or the booklet associated with the device.



MM/YY

Date of Manufacture/ Manufacturer's name symbol. This symbol indicates the date of manufacture of the device and the name of the manufacturer



WEEE directive symbol. Unwanted equipment bearing the Waste Electrical and Electronic Equipment (WEEE) Directive symbol requires separate waste collection. (See disposal section at the end of this chapter)



Further information is available on request.

Safety Standards

IEC Standard - International Standard - Medical Electrical Equipment

IEC 60601-1:2012 General requirements for safety



WARNING:

This equipment is not intended to be modified or serviced by the user. No user serviceable parts inside. Refer servicing to authorised ADInstruments service centre.

General Safety Instructions

To achieve the optimal degree of subject and operator safety, consideration should be given to the following guidelines when setting up a PowerLab system either as stand-alone equipment or when using PowerLab equipment in conjunction with other equipment. Failure to do so may compromise the inherent safety measures designed into PowerLab equipment.

The following guidelines are based on principles outlined in the international safety standard IEC 60601-1: *General requirements for safety – Collateral standard: Safety requirements for medical systems*. Reference to this standard is required when setting up a system for human connection. The user is responsible for ensuring any particular configuration of equipment complies with IEC60601-1-1.

PowerLab systems (and many other devices) require the connection of a personal computer for operation. This personal computer should be certified as complying with IEC 60950 and should be located outside a 1.8 m radius from the subject (so that the subject cannot touch it while connected to the system). Within this 1.8 m radius, only equipment complying with IEC 60601-1 should be present. Connecting a system in this way obviates the provision of additional safety measures and the measurement of leakage currents.

Accompanying documents for each piece of equipment in the system should be thoroughly examined prior to connection of the system.

While it is not possible to cover all arrangements of equipment in a system, some general guidelines for safe use of the equipment are presented below:

- Any electrical equipment which is located within the SUBJECT AREA should be approved to IEC 60601-1.
- Only connect those parts of equipment that are marked as an APPLIED PART to the subject. APPLIED PARTS may be recognized by the BF symbol which appears in the Regulatory Symbol section of these Safety Notes.
- Never connect parts which are marked as an APPLIED PART to those which are not marked as APPLIED PARTS.
- Do not touch the subject to which the PowerLab (or its peripherals) is connected at the same time as making contact with parts of the PowerLab (or its peripherals) that are not intended for contact to the subject.
- Cleaning and sterilization of equipment should be performed in accordance with manufacturer's instructions. The isolation barrier may be compromised if manufacturer's cleaning instructions are not followed.

WARNING:
To avoid risk of electric shock, this equipment must only be connected to a supply mains with protective earth

- The ambient environment (such as the temperature and relative humidity) of the system should be kept within the manufacturer’s specified range or the isolation barrier may be compromised.
- The entry of liquids into equipment may also compromise the isolation barrier. If spillage occurs, the manufacturer of the affected equipment should be contacted before using the equipment.
- The Powerlab depends on the presence of a Protective Earth for electrical safety. This is usually provided from the power outlet through a power cord but some facilities may not have a safety earth available from the power outlet. Such power outlets are identifiable by having only two connections on the power outlet instead of three. If this is the case, a protective earth must be connected to the PowerLab to ensure electrical safety. A suitable means of achieving this is to use the Ground Connector (sometimes known as a POAG) mentioned in the *Rear Panel section* of this Owner’s Guide.
- If using the Ground Connector for protective earthing, the attached wire must be cable of carrying the maximum current allowed by the circuit breaker and must be electrically insulated. It must be connected to an equi-potential source (a metal stake drive into the soil is a typical situation). A licensed electrician must perform this installation.
- Power cords should never be modified so as to remove the earth connection. The integrity of the Protective Earth connection between each piece of equipment and the Protective Earth should be verified regularly by qualified personnel.
- PowerLabs are compatible with electrical safety devices (sometimes known as Safety Switches, Ground fault circuit interruptor, Residual Current Devices or Earth-leakage Circuit Breaker). ADInstruments recommends the use of such devices supplied in fixed wiring installations.
- Avoid using multiple portable socket-outlets (such as power boards) where possible as they provide an inherently less safe environment with respect to electrical hazards. Individual connection of each piece of equipment to fixed mains socket-outlets is the preferred means of connection.
- When used in ambient temperatures of 38 degrees Celcius and above, do not touch PowerLab enclosure continuously for more than a minute.
- To safely shut down the PowerLab, press the stop button and then close LabChart. Turn the PowerLab off at the inlet switch.

If multiple portable socket outlets are used, they are subject to the following constraints:

- They shall not be placed on the floor.
- Additional multiple portable socket outlets or extension cords shall not be connected to the system.
- They shall only be used for supplying power to equipment which is intended to form part of the system.

Bio Amp Safety Instructions

The Bio Amp inputs displaying any of the safety symbols are electrically isolated from the mains supply in order to prevent current flow that may otherwise result in injury to the subject. Several points must be observed for safe operation of the Bio Amp:



- All PowerLab units with a built-in Bio Amp are supplied with a 3-lead or 5-lead Bio Amp subject cable and lead wire system. Bio Amps are only safe for human connection if used with the supplied subject cable and lead wires.
- All PowerLab units with a built-in Bio Amp are not defibrillator-protected. Using the Bio Amp to record signals during defibrillator discharges may damage the input stages of the amplifiers. This may result in a safety hazard.
- Never use damaged Bio Amp cables or leads. Damaged cables and leads must always be replaced before any connection to humans is made.

Isolated Stimulator Safety Instructions

The Isolated Stimulator outputs from the PowerLab with a built-in isolated stimulator are electrically isolated and safe for human connection. However, they can produce pulses of up to 100 V at up to 20 mA. Injury can still occur from careless use of these devices. Several points must be observed for safe operation of the Isolated Stimulator:

- The Stimulus Isolator must only be used with the supplied bar stimulus electrode.
- The Isolated Stimulator output must not be used with individual (physically separate) stimulating electrodes.
- Stimulation must not be applied across the chest or head.
- Do not hold one electrode in each hand.
- Always use a suitable electrode cream or gel and proper skin preparation to ensure a low-impedance electrode contact. Using electrodes without electrode cream can result in burns to the skin or discomfort for the subject.
- Subjects with implantable or external cardiac pacemakers, a cardiac condition, or a history of epileptic episodes must not be subject to electrical stimulation.
- Always commence stimulation at the lowest current setting and slowly increase the current.
- Stop stimulation if the subject experiences pain or discomfort.
- Do not use faulty cables, or those that have exhibited intermittent faults.
- Do not attempt to measure or record the Isolated Stimulator output while connected to a subject using a PowerLab input or any other piece of equipment that does not carry the appropriate regulatory symbol (see Regulatory Symbols above).
- The Isolated Stimulator should not be used as a therapeutic device. The PowerLabs are not intended as diagnostic, therapeutic or patient care equipment. Doing so may result in severe risk to the safety of the subject

Always check the status indicator on the front panel. It will always flash green each time the stimulator delivers a current pulse. A yellow flash indicates an 'out-of-compliance' (OOC) condition that may be due to poor electrode contact or electrode cream drying up. Always ensure that there is good electrode contact at all times. Electrodes that are left on a subject for some time need to be checked for dry contacts. An electrode impedance meter can be used for this task.

- Always be alert for any adverse physiological effects in the subject. At the first sign of a problem, stimulation must be stopped, either from the software or by flicking down the safety switch on the front panel of any built-in Isolated Stimulator.

Cleaning and Sterilization

ADInstruments products may be wiped down with a lint free cloth moistened with industrial methylated spirit. Refer to the manufacturer's guidelines or the Data Card supplied with transducers and accessories for specific cleaning and sterilizing instructions.

Inspection and Maintenance

PowerLab systems and ADInstruments front-ends are all maintenance-free and do not require periodic calibration or adjustment to ensure safe operation. Internal diagnostic software performs system checks during power up and will report errors if a significant problem is found. There is no need to open the instrument for inspection or maintenance, and doing so within the warranty period will void the warranty.

Your PowerLab system can be periodically checked for basic safety by using an appropriate safety testing device. Tests such as earth leakage, earth bond, insulation resistance, subject leakage and auxiliary currents and power cable integrity can all be performed on the PowerLab system without having to remove the covers. Follow the instructions for the testing device if performing such tests. If the PowerLab system is found not to comply with such testing you should contact your ADInstruments representative to arrange for the equipment to be checked and serviced.

Environment

Electronic components are susceptible to corrosive substances and atmospheres, and must be kept away from laboratory chemicals.

Transport and Storage Conditions

- Temperature in the range 0–40 °C
- Non-condensing humidity in the range 0–95%.

Operating Conditions

- Temperature in the range 5–35 °C
- Non-condensing humidity in the range 0–90%.

Disposal

- Forward to recycling center or return to manufacturer.
- Unwanted equipment bearing the Waste Electrical and Electronic Equipment (WEEE) Directive symbol requires separate waste collection. For a product labeled with this symbol, either forward to a recycling center or contact your nearest ADInstruments representative for methods of disposal at the end of its working life.



WEEE Directive
symbol



Chapter 2

Overview

Your PowerLab® recording unit, together with a range of specialized application programs, provides a versatile data recording and analysis system when used with a Windows or Macintosh computer. This chapter provides an overview of the PowerLab system and describes the basic features, connectors and indicators of the PowerLab.

Note that the software supplied with the PowerLab should be installed before you connect the PowerLab to your computer.

Figure 2-1

The 26 series
PowerLabs



How to Use This Guide

This owner's guide describes how to set up and begin using your PowerLab recording unit. The chapters provide an overview of the PowerLab system (the combined software and hardware package), and a more detailed look at the features of your recording unit and its connection to your computer. The appendices provide technical information about the recording unit and solutions to problems. At the end of this guide is a glossary of hardware terms and an index.

Software Installation

You should install ADInstruments application software before connecting or using your PowerLab.

If you are using PowerLab with Lt please refer to the kuraCloud Desktop help available at <https://support.kuracloud.com/desktop-app>.

The Getting Started with PowerLab manual provides full installation instructions for the LabChart software.

PowerLab Check

Please do not attempt to connect the PowerLab to a power outlet or computer or turn it on until you have checked it as described below.

- 1.** Check that all items in the accompanying packing list are included in the box.
- 2.** Check that there are no obvious signs of external damage to the PowerLab.
- 3.** Check that there are no obvious signs of internal damage, such as rattling. Pick up the PowerLab, tilt it gently from side to side, and listen for anything that appears to be loose.

If anything is missing or the PowerLab seems to be damaged in any way, contact your authorized ADInstruments representative immediately. Up to date contact addresses are available from the ADInstruments website.

Connection information is in the next chapter.

The PowerLab

This section describes the connectors and indicators of the PowerLab 15T, 2/26, 4/26 and 26T.

The Front Panel

The front panel (Figure 1–1 to Figure 1–4) provides the connectors for obtaining external signals, and indicators for various functions. This section describes each of the front panel features:

- Power and Status indicator LEDs
- Trigger indicator LED and BNC connector (not on PowerLab 15T)
- Output BNC connectors
- Input DIN connectors
- Input BNC connectors (PowerLab 2/26 and 4/26 only)

For the PowerLab 15T and 26T:

- Isolated Stimulator switch, indicator LEDs and output connectors
- Bio Amp connector

Indicators

The Power and Status indicators on the front panel should flash briefly while the PowerLab is starting up. Under normal conditions, the Power indicator should glow blue and stay lit. This simply shows that the PowerLab is getting power.

The Status indicator should flash yellow and then stay green when the PowerLab is switched on, and again when an ADInstruments application is opened. It provides some visual indication of what the PowerLab is doing, and will flash different patterns and colors depending on the state of the PowerLab. See Table 2–1 for details.

Trigger

The external trigger connector of the PowerLab 2/26, 4/26 and 26T allows you to use an external signal to synchronize recording to an external event. This input can handle voltages of up to ± 12 V. The threshold voltage (the voltage above which the trigger circuit activates) is 2.0 volts for a rising edge. When the trigger threshold is crossed, the indicator beside the external trigger connector will glow yellow. The external trigger is described in more detail in Appendix A, and the software documentation covers its practical use in normal recording.

Figure 2-2
The front panel
of the
PowerLab 15T

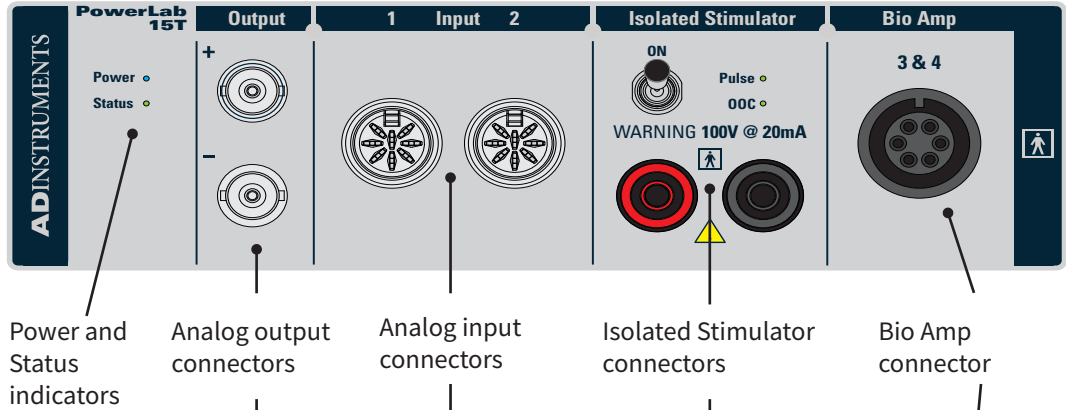

Power and Status indicators
Analog output connectors
Analog input connectors
Isolated Stimulator connectors
Bio Amp connector

Figure 2-3
The front panel
of the
PowerLab 26T

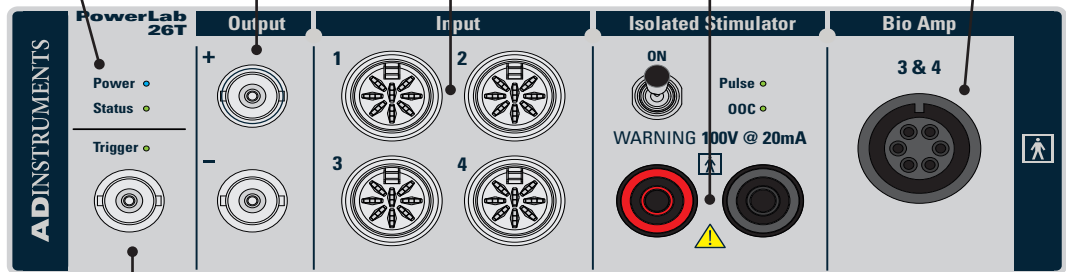

Trigger indicator and connector

Figure 2-4
The front panel
of the
PowerLab 2/26

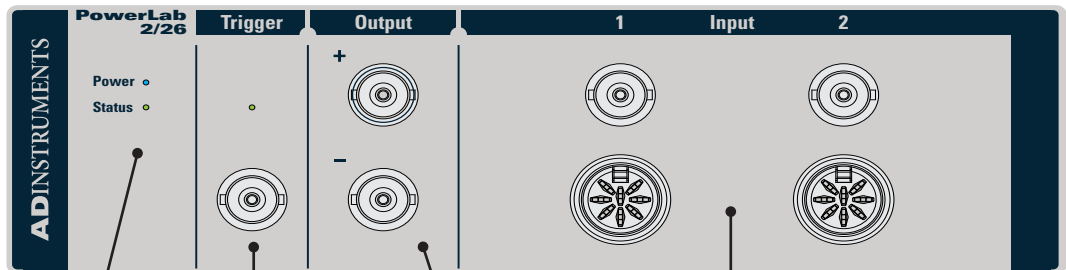

Power and Status indicators
Trigger indicator and connector
Analog output connectors
Analog input connectors

Figure 2-5
The front panel
of the
PowerLab 4/26

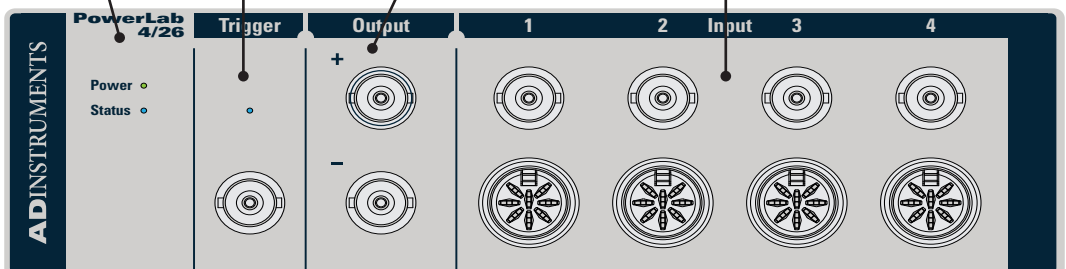

Analog Output

The PowerLab can generate a stimulus voltage through its analog output sockets (marked Output + and -), giving positive, negative or differential stimuli, depending on the sockets used and the software settings. By default, the outputs are used for complementary (differential) stimulation, where Output + is positive and Output - is negative.

When Output + is used, a positive stimulus voltage (set up in the software) gives a positive voltage output, and a negative voltage a negative one. When Output - is used, the voltage outputs are inverted. When both output sockets are used, the stimulus is the difference between the voltages at the positive and negative outputs: you could generate up to a 20-volt pulse, using a setting of ± 10 V.

You can use either the analog output or the isolated stimulator, but not both at once.

Analog Inputs

The analog inputs can record external signals from ± 10 V down to the microvolt (μ V) range, without the need for additional external amplification.

Each analog input has an independent programmable gain amplifier with its own filtering. Note that applying more than ± 15 V to the analog inputs can damage the circuitry.

The PowerLab 15T and 2/26 have two independent analog inputs marked Input 1 and 2; the PowerLab 26T and 4/26 have four such inputs marked 1-4.

These 8-pin DIN connectors can be used as:

- Single-ended inputs, where the difference between the signal and ground is recorded.
- Differential inputs, where the difference between the positive and negative input signals is recorded.
- Pod connectors, which allow the connection of ADInstruments pods, or those transducers designed for direct connection.

On the 15T and /26 model PowerLabs, the impedance between the earthing stud (ground connection) and the input connector grounds is close to zero.

Note that with the PowerLab 26T:

- ADInstruments front-ends, such as the FE221 Bridge Amp, can be used with inputs 1 and 2 and inputs 3 or 4 by connecting them with the DIN-to-BNC adaptor.
- When an ADInstruments pod or smart transducer is connected to either input 3 or 4, the corresponding Bio Amp input is turned off. Note that if you wish to use a non-smart transducer to input 3 or 4 an MLAC22 or MLAC31 smart adapter must be used.

WARNING:

PowerLab inputs and outputs are not electrically isolated (except for the Bio Amp input and the Isolated Stimulator outputs) and so should never be connected to human subjects.

Isolated Stimulator

The PowerLab 15T and 26T have a built-in, isolated, constant-current pulse stimulator that can be used for any general-purpose stimulation with humans. The Isolated Stimulator section of the front panel has two output sockets, two indicator lights and a safety switch. Note that you cannot use the analog output and the isolated stimulator at the same time.

The stimulus output is supplied via two 4 mm shrouded banana sockets; the left-hand (red) socket is positive, the right-hand (black) socket is negative. These are designed for use with shrouded male 4 mm plugs (the shrouding is to prevent accidental stimulation while fitting or removing the plugs). The bar stimulus electrode supplied with the PowerLab uses such plugs.

The output is capable of supplying 100 V pulses at currents up to 20 mA, so it should be treated with caution. The Isolated Stimulator Pulse indicator is an LED that indicates the current status of the Stimulator. It will flash green for every stimulus pulse, and may seem to glow green constantly at higher stimulus frequencies. The OOC (out-of-compliance) indicator is a yellow LED. When lit, it indicates that the output is overloaded or out of compliance (compliance is the ability to supply voltage to meet the required current). This means that the impedance of the tissue being stimulated is too high, or there is a poor electrical connection (possibly due to electrode drying), and that the Isolated Stimulator can no longer supply constant current stimulation. If this should happen, try reducing the output current amplitude, and check all connections.

To provide an additional level of safety, a safety switch is located on the front panel to allow the output to be switched on and off as needed. The switch should be flicked down to turn the output off: doing so disconnects the output sockets from the internal circuitry, allowing connections to be made safely while the PowerLab is on.

The Bio Amp Inputs (Inputs 3 and 4)

The PowerLab 15T and 26T have a connector for two Bio Amp inputs, marked Bio Amp Input 3 & 4. These biological amplifiers perform electrically isolated measurements of biological signals, such as electrocardiograms (ECG) and electromyograms (EMG). The two Bio Amp inputs have a common six-pin connector with a shared ground signal and are internally configured to use channels 3 and 4 of the PowerLab.

The PowerLab comes supplied with a 5-lead Bio Amp cable and lead wires. The Bio Amp inputs should only be used with the supplied Bio Amp cable and approved leads. Other cables may not meet safety requirements. Note: with the PowerLab 26T, connecting an ADInstruments pod or smart transducer to either analog input 3 or 4 turns off the corresponding Bio Amp input.

The Rear Panel

The rear panels of the PowerLab (Figure 1–5 to Figure 1–7) provide the sockets to connect the PowerLab to the computer, other devices and the power outlet. This section describes each of the rear panel features:

- Audio connector (PowerLab 26T only)
- I2C connector (not on PowerLab 15T)
- USB connector
- Digital input and output connectors (PowerLab 26T only)
- Ground connector
- Power switch and socket.

Figure 2–6
The rear panel
of the
PowerLab 15T

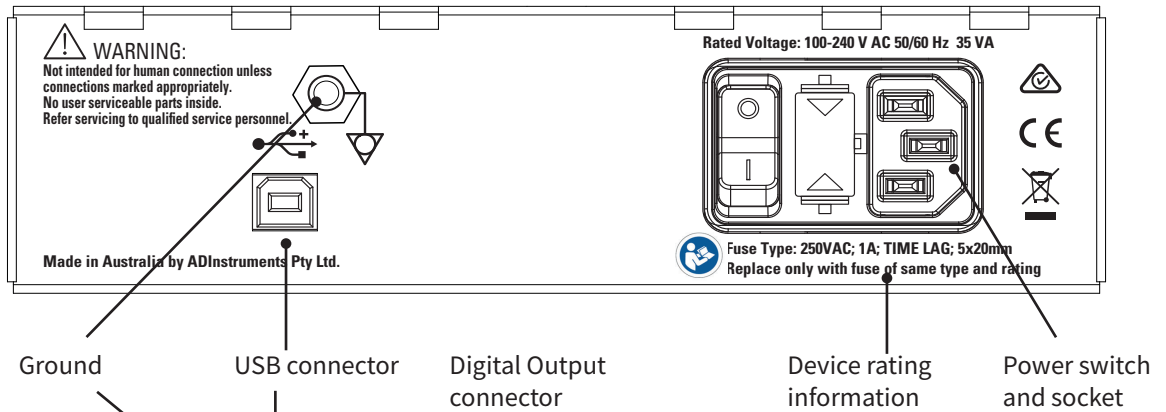

Figure 2–7
The rear panel
of the
PowerLab 26T

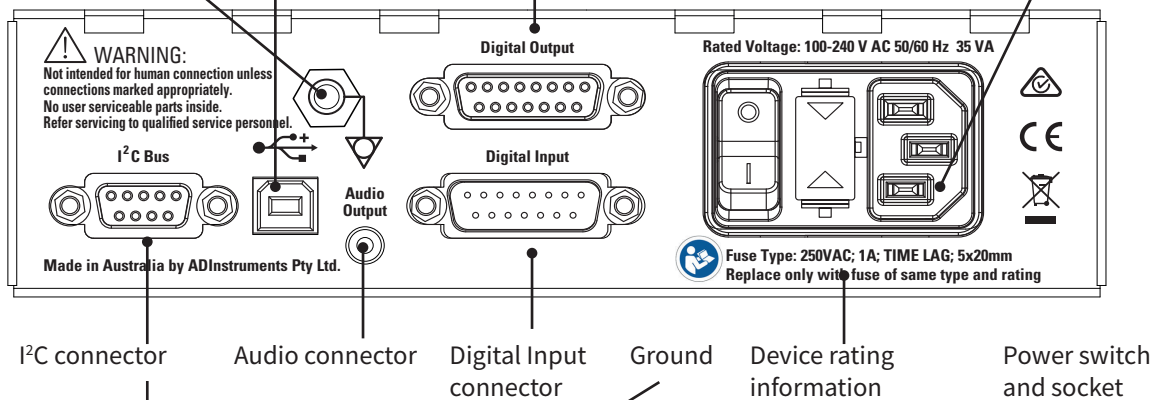
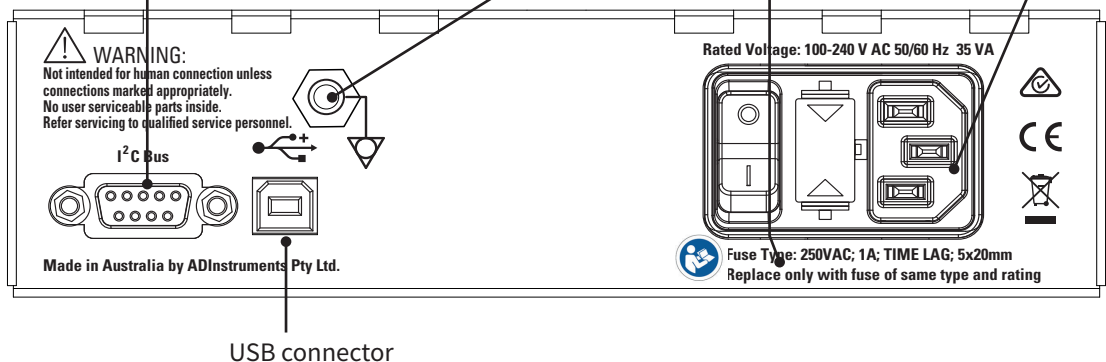

Figure 2–8
The rear panel
of the
PowerLab 2/26
and 4/26



WARNING:

As with all audio devices, there is a risk of temporary hearing damage if used carelessly. It is recommended headphones are attached to the PowerLab audio socket prior to attaching the headphones to ears.

Audio Connector

The PowerLab 26T has an audio output to monitor the Bio Amp channels. It provides stereo sound (using signals from Inputs 3 and 4). The 3.5 mm stereo socket can be used with a wide range of headphones or externally powered speakers. The audio output is particularly helpful when monitoring nerve firings, to assist in the placement of electrodes, for instance.

I²C Connector

The I2C port (not on PowerLab 15T) provides power and control signals for front-ends manufactured by ADInstruments. Many front-ends can be daisy-chained together and connected through the I2C port, so long as there are enough analog inputs on the PowerLab. A maximum current of 50 mA can be provided through this bus, so it should not be used for third-party devices that require more current than that.

USB Connector

The PowerLab connects to your computer using a USB 2.0 connector and cable, therefore your computer must have USB connectors to receive data from the PowerLab.

You can safely disconnect or reconnect a USB-connected PowerLab while the computer remains on. However, ADInstruments software should not be running while you do this. Read the details on USB in Appendix A of this guide before connecting your PowerLab to your computer.

Digital Input and Output Connectors

The digital input and output ports (PowerLab 26T only) let you monitor and control external devices, respectively, with the PowerLab.

The digital input monitors state changes: you can have a predefined comment automatically inserted during recording when a digital input changes to a particular state. The eight lines of the connector allow monitoring of up to eight devices. The digital output can turn on and off external devices, for example pumps, relays, and indicator lights, or can signal to some other device. The eight lines of the connector allow control of up to eight devices.

Technical details of the digital input and output connectors are given in Appendix A. Note that any cables connected to either the digital input or output must be less than 3 m in length in order to maintain EMC compliance.

More information on the use of digital inputs and outputs is given in the Help for the software.

Ground Connector

A special earthing (grounding) stud is provided on the rear panel of the PowerLab. This is an equipotential bonding connection post compatible with the DIN 42801 standard. The earthing stud is directly connected to the earth pin of the power socket and the PowerLab chassis. It is used as a primary earth connection (equipotential connection point) in situations that require this type of connection, or if there is no ground provided via the power cord. Safety standards in laboratories and similar environments may require additional grounding protection when connecting equipment to human subjects, and their relevant standards or guidelines should be observed.



Power Connector

The power switch on the back right of the PowerLab turns the PowerLab on and off; the 3-pin IEC power socket is used to connect your PowerLab to a power cable. The power supply is universal, and can use all common international mains power supplies (100–240 V AC, 50/60 Hz).



WARNING:

Do not position device so as to make it difficult to operate the disconnection device when an appliance coupler, mains plug or any other separable plug is used as a means for isolation.

The PowerLabs are now fitted with replaceable fuses. If the Power LED on the PowerLab, does not illuminate with power applied, it may be that one or both of the replaceable fuses has blown. Fuses should only be of the rating and type as specified below:

- 250VAC Slo Blo (usually marked “T”)
- 1A
- 20 x 5mm

Checking and replacing fuses

Ensure the power lead is disconnected before attempting to replace a fuse.

The fuses are contained in the fuse drawer. To remove the drawer, the top and bottom plastic tabs need to be squeezed simultaneously while pulling the drawer away from the PowerLab (a small flat-bladed tool is useful for this task). The old fuses should spring free of the drawer once removed from the inlet. Load the new fuses back into the drawer and carefully push back into the inlet. Note that the fuse drawer is polarized and can only be put back in one orientation. For further assistance please contact your nearest ADInstruments representative

Figure 2–9
Removing and replacing fuses

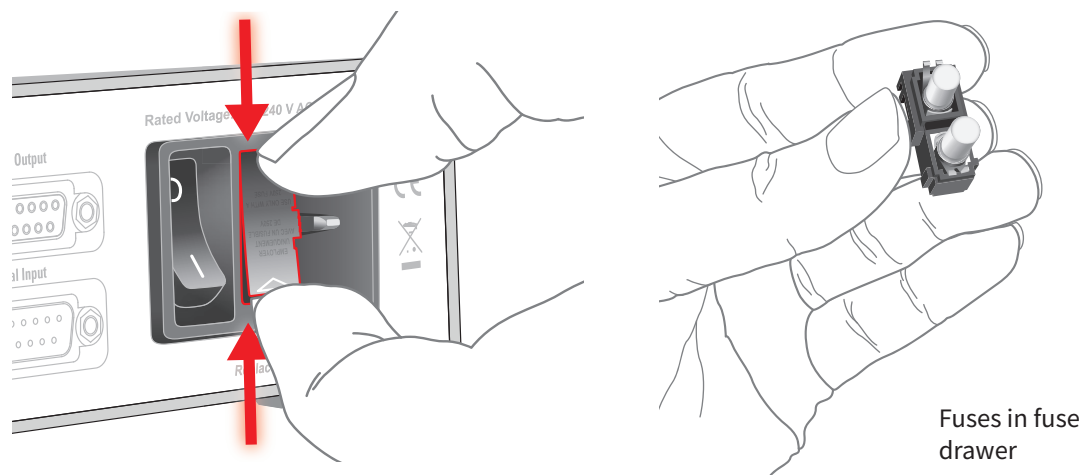

The Bio Amp Cable

Connections are made to the Bio Amp inputs using the supplied Bio Amp cable and leads. The cable plugs into the six-pin input socket on the front panel: a notch in the plug ensures that polarity is correct. Only the supplied Bio Amp cable and leads should be used. Other cables may not meet safety requirements. The PowerLab 26T and 15T are supplied with a 5-lead Bio Amp cable and lead wires; it uses a shared ground signal for its Bio Amp channels. The cable is of the sort often used for ECG or EMG work, a Tronomed D- 2540 cable, and has a cable yoke with five sockets for the leads.





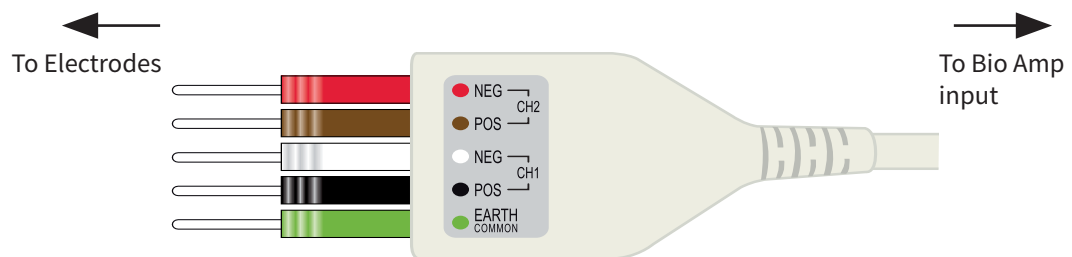

The supplied leads click into place in the cable yoke, and have snap connectors at the other end to connect to typical ECG electrodes. The leads are color-coded for ease of identification.

ADInstruments supplies other types of lead wires that connect to the Bio Amp cable yoke, such as EEG Flat Electrodes. Also available are disposable and reusable electrodes, electrode cream (for reusable electrodes), electrode paste, and abrasive gel for lightly abrading the skin before the electrodes are attached.

Figure 2-10
The Bio Amp
cable yoke, with
5 leads attached



Supplied Accessories

Accessory	Applied part type
MLADDF30 Stimulating Bar Electrode	 BF
MLA2540 5 Lead Shielded Bio Amp	 BF
MLA2505 Shielded Lead Wires (5 pk)	 BF
MLAC22 BNC to DIN Smart Adapter	-
MLAC25 DIN 8 Plug to BNC Cable (2m)	-
MLC405 USB Cable	-
TN1012/ST Pulse Transducer	 B
MLT004/ST Grip force transducer	 B
MLA92/D Push button switch	 B
MLAC01 BNC to BNC Cable (1m)	-

Note: Refer Glossary for the definition of an Applied part

Other ADInstruments Hardware

ADInstruments has a range of optional devices that can be connected to your PowerLab. They extend the types of experiments you can conduct and the data you can record, and include:

- Pods — small, low-cost signal conditioners for specific tasks, for use with precalibrated transducers, and which are automatically recognized by the PowerLab and application software.
- Front-ends — advanced signal conditioners which are automatically recognized by the PowerLab and software, and which provide specialized data acquisition features (not used with the PowerLab 15T).
- Transducers — either for use with a specific pod, or which plug directly into the PowerLab, depending on their type.

A PowerLab can usually have as many pods or transducers connected to it as it has appropriate connectors. All are easily transferred between PowerLabs.

Full information on such hardware is available from your local ADInstruments representative or from the ADInstruments website.



Chapter 3

Setting Up

This chapter describes:

- The PowerLab's internal self-test.
- The USB connection between the PowerLab and the computer.
- The software features specific to the built-in Isolated Stimulator and Bio Amp.

Figure 3-1

PowerLab 26 series:
PowerLab 2/26, 4/26
and 26T



The PowerLab Self-test

The PowerLab performs a diagnostic self-test each time it is switched on.

Before connecting it to the computer for the first time, you should test that your PowerLab is functioning properly, as follows:

1. Connect the PowerLab to a power outlet using the power cable that came with your unit. Turn on the power at the wall.
2. Turn on the power switch located on the rear of the unit, and observe the Power and Status indicators on the front panel while the PowerLab is starting up:
 - The Power indicator should glow blue while the PowerLab is on.
 - The Status indicator should flash yellow and then stay green.

If the Status indicator stays green, the internal diagnostic check has completed successfully. The PowerLab can now be switched off and connected to the computer.

Table 3-1
Status Indicator codes

<i>Status Indicator</i>	<i>Meaning</i>
Green	Idle, initialized, and waiting for a command from the computer.
Orange	Sampling, or communicating with the computer.
Four red flashes then one orange	The PowerLab has detected a low-level software or hardware fault. It will repeat until the PowerLab is turned off.
Red flashes	The PowerLab has detected an internal fault during the power-up test. It will repeat until the PowerLab is turned off.

If the Power indicator does not glow blue when the power switch is turned on, then there is a problem with the power source, power cable or PowerLab itself. Check the connections and cables.

If the Status indicator is flashing red, then the PowerLab has detected an error during the self-test. Restarting the PowerLab should clear a temporary problem.

If the PowerLab does not seem to be getting power, or the Status indicator flashes red, even after restarting, refer to the ADInstruments website (www.adinstruments.com/support/tsupport/education) or contact your authorized ADInstruments representative. Do not attempt to repair the PowerLab yourself.

Figure 3-2
USB Icon



Connecting the PowerLab

Use the USB cable supplied with your PowerLab to connect the USB port on the back panel to the USB port on the computer, or to an active USB hub connected to the computer (see Figure 2-2). USB ports and cables should be marked with a trident-like icon (Figure 2-1). Further detail about USB connections is provided on page 41 of Appendix A.

Figure 3-3
Connecting a
PowerLab to a
computer with USB

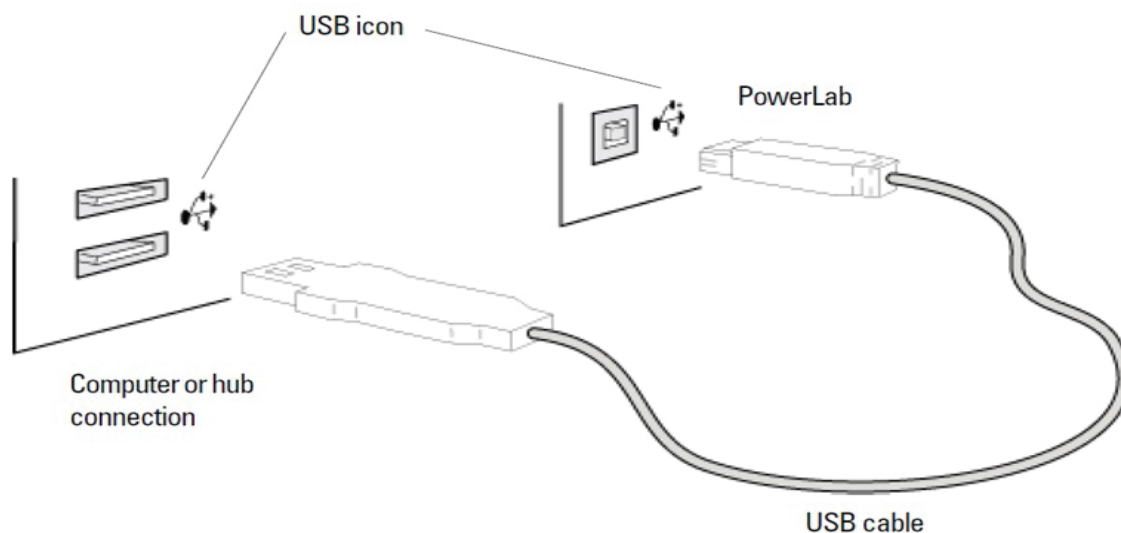

ADInstruments Software

The integration of hardware and software in the PowerLab system allows all hardware functions, including those of any connected signal conditioners, to be controlled from within the software.

Lt Software

When the PowerLab is used with Lt, the Lt contents have pre-configured settings for the PowerLab, and for any signal conditioners needed for the experiment. For more information about the Lt application please refer to <https://support.kuracloud.com/>

LabChart Software

When the PowerLab is used with the LabChart application, the PowerLab functions are set up from within that software. The software controls for most functions, such as sampling speed, are described in the documentation for LabChart. For more information about the LabChart application please refer to the LabChart Help.

The software controls specific to the signal conditioners built into the PowerLab 26T and 15T (an Isolated Stimulator and two Bio Amps) are described below.

The Isolated Stimulator

The PowerLab 26T and 15T have both normal and isolated outputs, and you can switch between them in software. The Isolated Stimulator provides software-controlled, isolated, constant-current pulse stimuli that can be used with human subjects. The stimulus is produced at the outputs on the front panel of the Stimulus Isolator. The stimulus is independent of the PowerLab sampling rate and can be generated whether the PowerLab is sampling or not. The stimulus is set up using the Stimulator dialog.

Choose **Setup > Stimulator....** to display the Stimulator dialog (Figure 2-3).

When setting up the Stimulus Isolator, you:

- Choose how stimulation should start.
- Choose a preconfigured stimulus type or mode.
- Optionally, on Windows, create a custom stimulus waveform.
- Set stimulus parameters, such as start delay, pulse width and current amplitude.

Note that if you connect a Stimulus Isolator front-end to a PowerLab 15T or 26/T, only the external stimulator is used.

Choosing How Stimulation Should Start

Stimulation can be set to start in different ways:

- **When sampling starts:** stimulation begins automatically when the LabChart **Start** button is clicked, and continues until sampling stops. Use the **On** and **Off** buttons to control pulse delivery, if necessary.
- **Manually:** stimulation begins when **Stimulate** in the dialog is clicked, and continues until sampling stops. Use the **On** and **Off** buttons to control pulse delivery, if necessary.
- **Independently of sampling:** stimulation begins when **On** in the dialog is clicked, whether or not LabChart is sampling.

Figure 3-4
The Stimulator dialog,
Windows

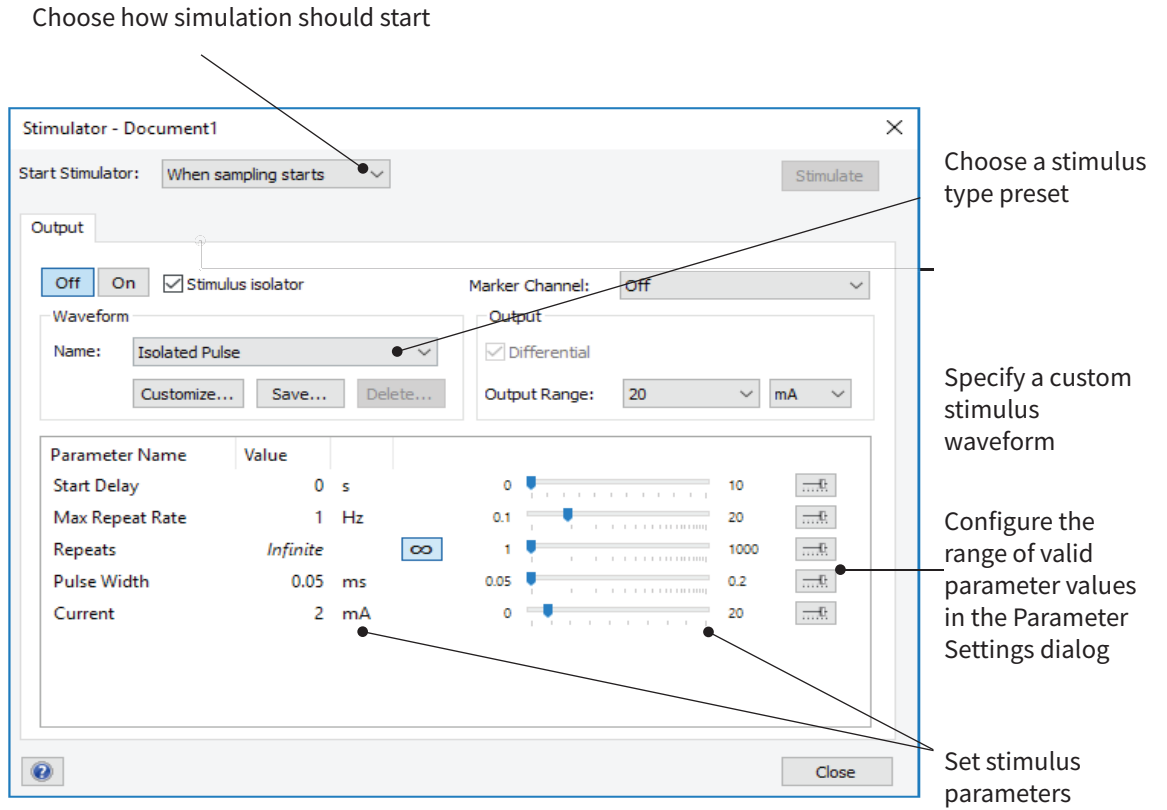

Choosing a Stimulus Type

The Stimulator only offers the Isolated Pulse stimulation mode. This generates a rectangular pulse stimulus that starts at zero current, is raised to the set current amplitude for the set pulse width (duration), and then falls to zero current again. By default, the stimulator is off and the current amplitude is set to zero.

Creating a Custom Stimulus Waveform

In LabChart, you can:

- Specify whether parameter controls are displayed in the Stimulator and Stimulator Panel dialogs.
- Define a sequence of segments to create a custom stimulus waveform.

Click Custom... to display the Waveform Customization dialog. Further details about using this dialog are available in the LabChart Help.

Setting Stimulus Parameters

You use the text boxes and sliders to set values for the stimulus parameters. In LabChart, you can use the Settings dialog for each parameter to configure the range of values available to the parameter text box and slider controls. Using suitable values can improve the precision of control over the stimulus parameter when using the slider and spinner controls.

In LabChart, the following stimulus parameters can be set:

Start Delay: the wait time before stimulation is delivered, once the stimulus waveform has been started.

Repeats: the number of times the stimulus waveform is repeated, once started.

Max Repeat Rate: the maximum frequency with which the stimulus waveform is repeated (either 0.1–20 Hz or 6–1200 /min), or the interval between each pulse start (0.05–10 s).

Pulse Width: the duration of each pulse. The pulse duration is restricted to the range from 50 μ s to 200 μ s for safety reasons.

Current: the amplitude of the stimulus current (0 to 20 mA).

End Delay: the wait time at the end of a stimulus segment, after which the next segment is delivered. This is not the same as a Delay segment.

Marker Channel

If you choose a channel from the Marker Channel pop-up menu, then the start time of a stimulus pulse is marked by a small data spike (this adds to any data in that channel).

The Stimulator Panel

Once you have set up stimulation using the Stimulator dialog, you can easily start or stop stimulation or change settings while sampling, by using the Stimulator Panel. Choose Stimulator Panel from the Setup menu to open it

You can specify which parameter controls are displayed in the panel using checkboxes in the Panel column of the Waveform Customization dialog. See the LabChart Help for details.

The Stimulator Panel ‘floats’ in front of the active window, can be moved around with its title bar, and can only be dismissed by clicking its close box.

Figure 3-5
The Stimulator Panel

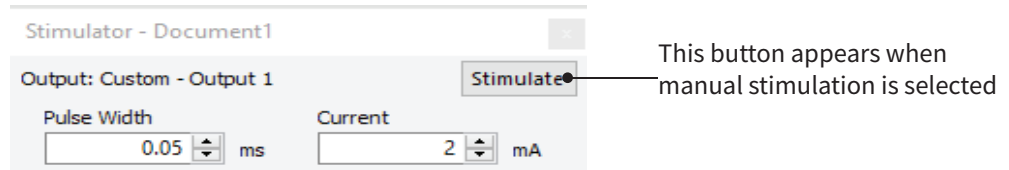

The Bio Amp

The PowerLab 26T and 15T have two-channel Bio Amps, which are internally configured to use channels 3 and 4. The Bio Amp dialog allows software control of the combined input amplifiers and filters in the PowerLab and Bio Amps. The signal present at a channel’s input is displayed so that you can see the effects of changes straight away. Once settings in the dialog are changed, click OK to apply them.

The Bio Amp dialog appears when you choose Bio Amp... from a Channel drop-down menu (or click Bio Amp... in the Input Settings column in the Channel Settings dialog). To set up many channels quickly, click the arrows by the dialog title, or press the right or left arrow keys on the keyboard, to move to the equivalent dialogs for adjacent channels. This skips channels that are turned off. The channel number is shown next to the arrows, and the channel title (if any) is shown in the vertical Amplitude axis of the dialog.

Signal Display

The input signal is displayed so you can see the effect of changing the settings— no data is recorded while the Bio Amp dialog is open. The instantaneous signal value is shown at the top left of the display area.

You can stop the signal scrolling by clicking the Pause button at the bottom right of the data display area. Time-axis scaling controls work in a similar way to the Chart View.

Setting the Range

The Range pop-up menu lets you select the input range, or sensitivity, of the channel — the combined range of the PowerLab and Bio Amp. Changing the range in the Bio Amp dialog is equivalent to changing it in the Chart window. The default setting (if you have not loaded a settings file) is 20 mV, rather than 10 V, and the ranges go down to 100 μ V in eight steps.

Figure 3-6
The Bio Amp dialog
for Windows

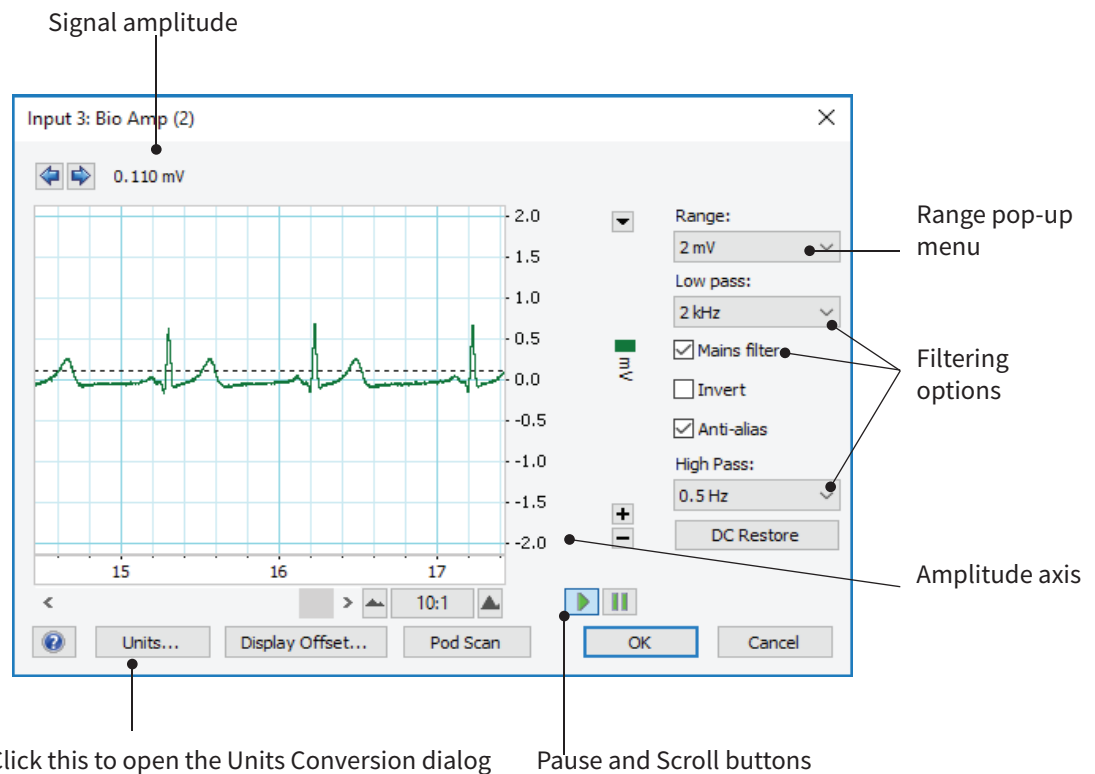

Filtering

Each of the Bio Amps in the PowerLab has low-pass, high-pass and mains filter circuitry that can be adjusted to suit the recording. Note: the settings for one filter type may restrict the possible settings for the other.

High-Pass Filtering. The High Pass pop-up menu gives a choice of two high-pass filters: 0.5 and 10 Hz. The high-pass filter allows high frequencies in the signal to pass, and removes frequency components below the filter frequency (including any DC signal). These filters are useful for removing slowly moving baselines, such as motion or respiration artifacts, particularly in ECG (EKG) recordings.

Low-Pass Filtering. The Low pass pop-up menu gives the choice of eight low-pass filters: 10, 20, 50, 100, 200 and 500 Hz, and 1 and 2 kHz. These filters are useful for removing high-frequency signals, such as noise.

DC Restore. Click DC Restore to reduce the time constant of the high-pass filter so that the filter can rapidly adjust to an altered baseline value.

Mains Filter. The mains filter allows you to remove interference at the mains frequency (typically 50 or 60 Hz). This is an adaptive filter and should only be used when the signal to mains noise ratio is less than 36 dB, that is the mains noise amplitude is greater than 1/64 of the signal amplitude. More details on the mains filter can be found in the LabChart Help Center.

Anti-alias.

Select Anti-alias to apply a sample rate-dependent low-pass filter that prevents aliasing artifacts. The input signal is sampled and digitized at 100 kHz. The AD converter incorporates a low-pass filter of fixed cutoff frequency (49 kHz). When LabChart samples at 100 kHz, the converted samples are passed on unchanged. At all other LabChart sampling rates, an additional (digital) filter is optionally applied to the AD converter's 100 kHz output stream. This is a decimating FIR filter whose cutoff frequency is set to the Nyquist value: half the LabChart sampling frequency. It thus acts as an automatic anti-aliasing filter, providing optimum noise rejection in the recorded data. Attenuation in the stop band is at least 40 dB. Note that anti-aliasing is disabled at sampling rates below 100 Hz so as to prevent the delay that otherwise occurs as samples pass through the FIR filters.

The anti-aliasing filter characteristics are chosen to give the fastest step response without overshoot (corresponding to an analog Bessel filter). Such a response is suited to most types of physiological recordings. In the frequency domain, the filter response starts to roll off well below the cutoff frequency. In certain (relatively uncommon) types of measurement, a maximally flat response is desirable; this can be obtained by turning anti-aliasing off.

Inverting the Signal

Selecting Invert allows you to invert the signal on the screen. It provides a simple way to change the polarity of the recorded signal without having to swap the connections to the recording electrodes.



Chapter 4

Technical Aspects and Specifications

This appendix describes some of the important technical aspects of your PowerLab, to give some insight into how they work. You do not need to know the material here to use your PowerLab. It is likely to be of special interest to the technically minded, indicating what the PowerLab can and cannot do, and its suitability for particular purposes. You should not use it as a service manual: user modification of the PowerLab voids your rights under warranty.

Figure 4-1
PowerLabs 15T
and 26T



How it Works

The PowerLab is essentially a smart peripheral device specifically designed to perform the various functions needed for data acquisition, signal conditioning, and pre-processing. It contains its own microprocessor, memory and specialized analog amplifiers for signal conditioning.

All sampling, output and communication functions are controlled by an internal microprocessor. The PowerLab uses USB 2.0 to communicate with the computer, if the computer is USB 2.0 compliant. This provides data transfer rates of up to 480 Mbits per second. If the computer only supports USB 1.1 the data transfer rate will be slower.

The 15T and 2/26 PowerLabs have two analog inputs, whereas the 26T and 4/26 PowerLabs have four analog inputs. They are used to record external signals prior to digitizing. Each of these input amplifiers connects to a separate 16-bit ADC (analog-to-digital converter) that samples at 100 000 samples per second. The sampling process is handled independently of the processor core through a sampling control engine using direct memory access. The CPU assembles groups of samples into blocks and then transmits them to the computer, where the software receives, records and displays the data.

Two 16-bit DACs (digital-to-analog converter) are used to provide an analog output or stimulation capability through the analog outputs of the PowerLab (marked 'Output' on the front panel). The DACs can produce constant DC voltage levels or waveforms under software control. Stimulation frequency is completely independent of the analog input sampling rate. The output of the DACs is fed through a programmable attenuation network to produce different output ranges. The signal is then split into a positive and negative output through buffer amplifiers. The outputs are capable of driving up to 20 mA into a load.

The PowerLab uses an IEC60601-1 (medically) compliant switching power supply. This provides a universal input that handles all common international voltage supplies and frequencies without the need to change voltage ranges. This power supply is also internally protected in the case of a problem. It is important to note that the PowerLab has a limited amount of power available for external devices. Because of these power limitations, you should not use the PowerLab as a power source for external devices other than those produced by ADInstruments.

The Analog Inputs

CAUTION:

Applying more than ± 15 V to the input can damage the input circuits.

PowerLab input amplifiers have been designed with a considerable amount of computer-controlled gain (up to $\times 2000$). Thus it is possible to record a variety of signals without any external pre-amplification. Each analog input is a separate DC amplifier with programmable gain able to be set independently (the gain is set through the software range control). The PowerLab inputs can be set by the software to be either single-ended or differential. In the differential setting, the amplifier measures the difference between the positive and negative inputs, irrespective of ground.

It is important to note that the PowerLab grounds the inputs to amplifiers not in use. It also grounds each amplifier and measures the DC offset voltage when the gain is changed. In this way, the software corrects for any DC drift or offset in the circuits that may develop over time or between readings.

Input impedance is one megohm. (On the 15T and /26 model PowerLabs, the impedance between the earthing stud (ground connection) and the input connector grounds is close to zero.)

WARNING:

Analog outputs are not to be used for connection to human subjects.

The Analog Outputs

The analog outputs provide computer-controlled variable outputs (± 10 V) that can be used with the LabChart and Scope applications either directly as a stimulator, or to control peripheral devices. All stimulation voltage is generated by the PowerLab via the output sockets on the front of the PowerLab (marked Output + and -), giving positive, negative, differential, depending on the sockets used and the software settings.

Figure 4-2

The analog output stage, set up for a differential stimulus

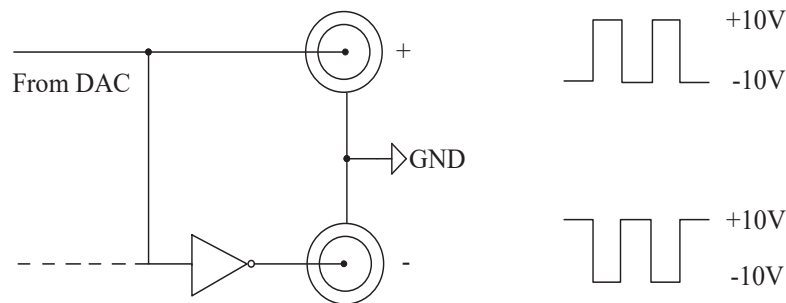

By default, the outputs are used for complementary (differential) stimulation, where Output + is positive and Output - is negative. When Output + is used, a positive stimulus voltage (set up in LabChart or Scope) gives a positive voltage output, and a negative voltage a negative one. When Output - is used, the voltage outputs are inverted. When both output sockets are used, the stimulus is the difference between the voltages at the positive and negative outputs: you could generate up to a 20-volt pulse, given a ± 10 V range setting.

The External Trigger

The external trigger input (not on PowerLab 15T) is marked 'Trigger' on the front panel and provides a digital input for synchronizing sampling with external devices. It allows either a voltage level or a contact closure to trigger recording. Note that for either mode the trigger signal must be present for at least 3 μs to register as an event. When a trigger event occurs, the indicator light will glow yellow.

When set up through software to use a voltage level, above which a rising edge trigger event is registered, the external trigger level is 2 V. The external trigger input is off for input voltages between -12 V and the external trigger level, and on between that level and +12 V. The input will be overloaded if the voltage is outside the range -12 V to +12 V. The trigger input is isolated when set up for a voltage level.

The equivalent circuit of the external trigger has two diode protection. In the external contact closure mode, the trigger input will respond to a direct short between the center pin and outer ring of the BNC. This can be achieved with an external relay contact, a manual push-button or a microswitch. The trigger input is not electrically isolated when set up for contact closure.

Figure 4-3

The equivalent circuit of the external trigger input, when set up for a voltage level

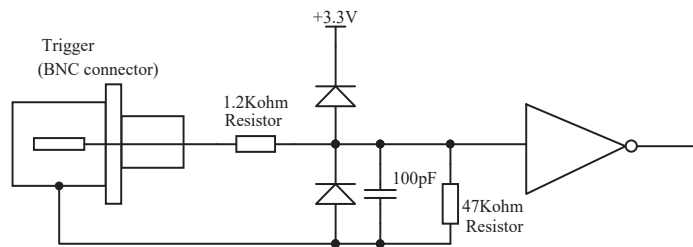

The equivalent circuit for the external closure trigger is shown in Figure A-3. The BNC input connects to a TTL circuit via a resistor circuit and has two-diode protection.

Figure 4-4

The equivalent circuit of the external trigger input, when set up for contact closure

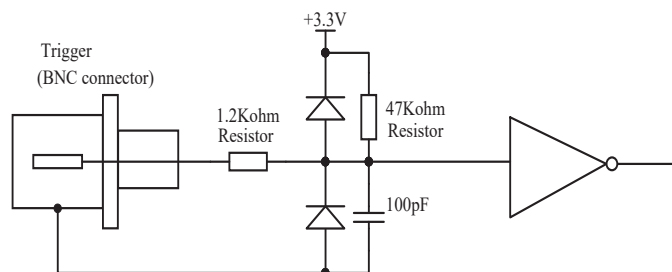

In order for the external trigger to work, a voltage must be applied between the outer ring and the inner pin of the connector. Applying a voltage just to the center pin may not work.

Bio Amp Input (Inputs 3 & 4)

The PowerLab 15T and 26T have one common connector for two Bio Amp channels, marked Bio Amp 3 & 4. These two independently controllable, electrically isolated, biological amplifiers are suitable for a range of basic physiological measurements. The two Bio Amp inputs are internally configured to use channels 3 and 4 of the PowerLab. The Bio Amps have a common six-pin connector with a shared ground.

Each amplifier consists of an electrically isolated, AC coupled, differential amplifier with programmable gain able to be set independently (the gain is set through the software range control: the less the range, the more the gain). The gain is controlled by optically isolated digital control signals from the nonisolated section. The signal is then applied to an isolation amplifier which provides electrical isolation of the input stage from the supply.

The non-isolated stage consists of a series of filters and amplifiers. The first part of the stage is a high-pass filter designed to remove any DC components from the signal and the isolated stage. This is followed by amplification and an active notch filter. The notch can be turned on or off under software control as needed. The frequency of the notch filter is automatically set to either 50 or 60 Hz to match the frequency of the connected power supply.

The low-pass filter is an eighth-order, switched-capacitance, Bessel-type filter, with a software-selectable range of frequencies. The output of the biological amplifier is then passed to the standard PowerLab input amplifier circuit. On the PowerLab 26T an amplifier connected to the output of the biological amplifier is used to provide an audio output facility that can be used with headphones or powered speakers.

Figure 4-5
Block diagram for one
of the two
Bio Amplifiers
(Input 3 & 4)

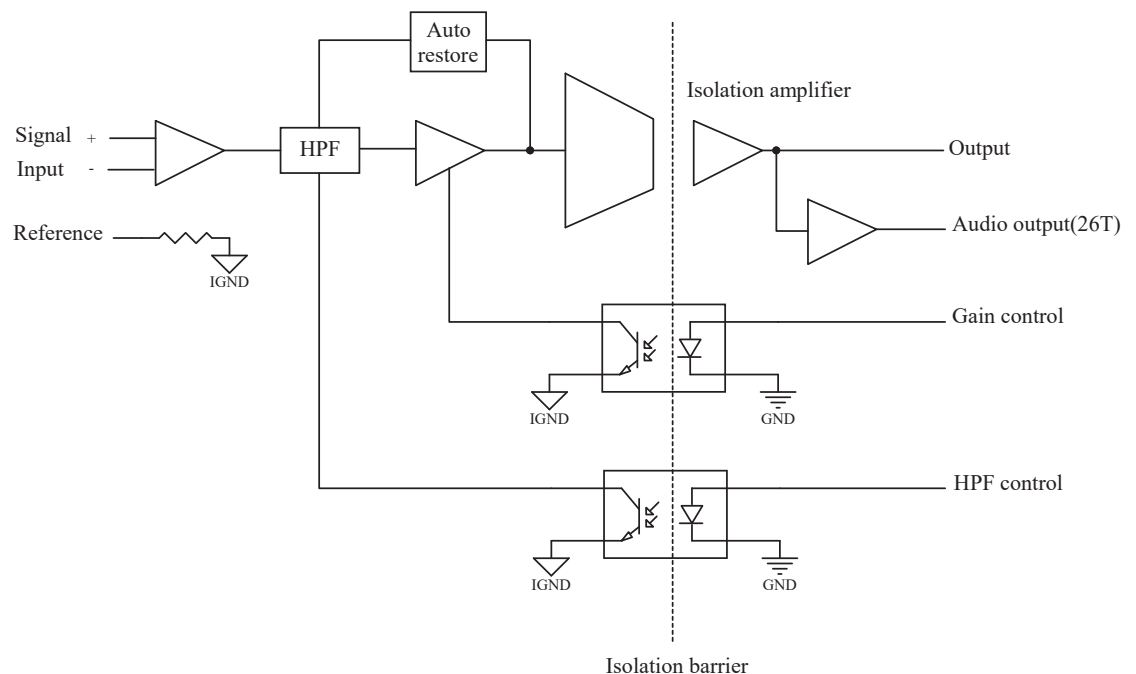

The Isolated Stimulator Output

The Isolated Stimulator output provides a software-controlled, isolated, constant-current pulse stimulator that can be used for any general purpose stimulation.

The output stage consists of a high-voltage, constant-current source that can produce pulses of variable duration and amplitude under full software control. The current source can deliver pulses up to 20 mA at 100 V maximum compliance levels; its amplitude is controlled by optically isolated digital control signals from the non-isolated section. The output to the subject is through high-isolation optical couplers.

Software and hardware safety features limit the energy delivered by the pulses to within international safety standards. The pulse duration of the stimulator can be set from 50 μs to 200 μs , and the pulse frequency can be adjusted between 1 pulse per minute and 20 pulses per second.

The Isolated Stimulator Pulse indicator is an LED that is used to indicate the current status of the Stimulator. It will flash green forevery stimulus pulse, and may seem to glow green constantly at higher stimulus frequencies. The OOC (out-of-compliance) indicator is a yellow LED. When lit, it indicates that the output is overloaded or out of compliance (compliance is the ability to supply voltage to meet the required current). This means that the impedance of the tissue being stimulated is too high, or there is a poor electrical connection (possibly due to electrode drying), and that the Isolated Stimulator can no longer supply constant current stimulation. If this should happen, try reducing the output current amplitude, and check all connections.

Figure 4-6
Block diagram of the
Isolated Stimulator

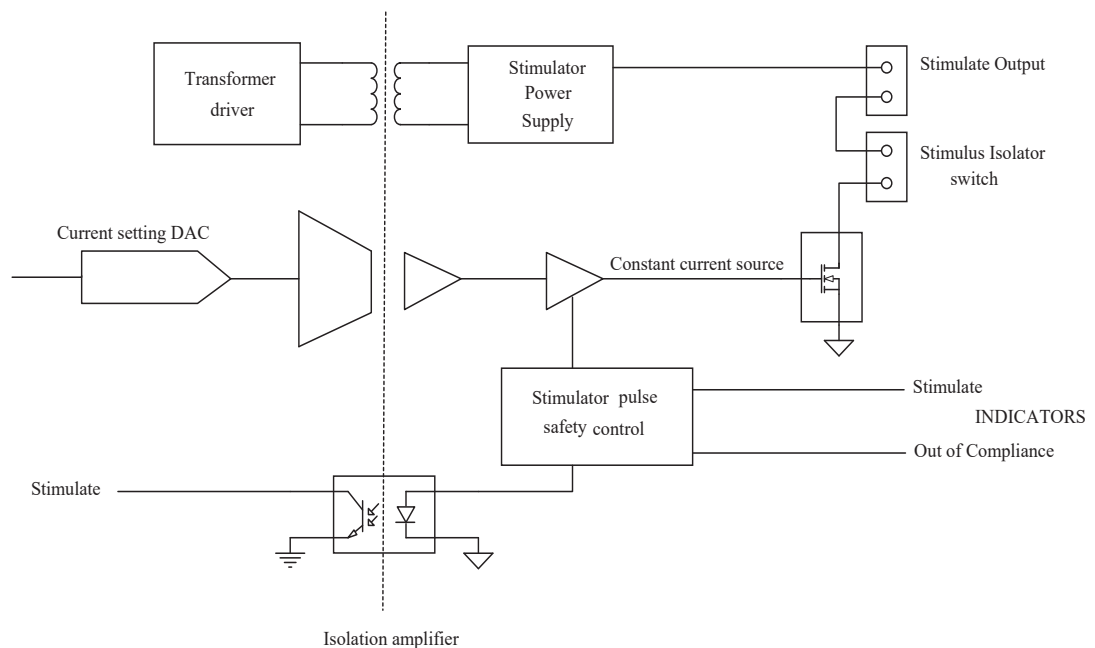

PowerLab Accuracy

The PowerLab was calibrated at the factory to an accuracy of better than 0.1%. Some 'zero drift' or 'gain drift' can occur with time. This can affect the accuracy of measurements, especially at the highest input gains. The unit can be recalibrated, but in most circumstances this is not necessary in its lifetime.

Calibration facilities. It is good practice to calibrate a measuring system from the transducer to the output. After applying two known values to a transducer (say at 20% and 80% of full scale) and recording the signal, you can use the units conversion feature of ADInstruments software to convert and display transducer readings in the appropriate units. This will compensate for any minor inaccuracies in amplifier gain and transducer calibration.

DC drift compensation. When a recording is started manually or by triggering, or the gain is changed, the input signal to the amplifier is grounded and any DC, due to amplifier drift of temperature and age, is measured. The measured voltage is removed from the input signal through software correction, in a process transparent to the user.

Connectors

This section of the appendix contains 'pinout' and electrical details of some of the connectors fitted to the PowerLab. You should read it carefully before attempting to connect cables other than those supplied with the unit to the PowerLab. Using cables that are wired incorrectly can cause internal damage to the PowerLab and will void your rights under warranty. For further information or advice please contact your nearest ADInstruments representative.

Digital Input and Output

The digital input port and digital output port are 15-pin connectors situated on the back panel of the PowerLab 26T. The eight digital input lines respond to 3.3 V logic signals with a threshold of 1.2 V, and have a 10 k Ω input impedance. The eight digital output lines can turn on and off, or signal to, up to eight external TTL devices. The digital output lines are capable of driving 8 mA each.

The inputs and outputs conform to industry standard HCMOS structures powered with a 5 V supply. The digital input and output ports both have a pin which can supply power to solid-state relays or similar devices. Total aggregate current from these pins is 200 mA continuous at 5 V. The digital input signals should not exceed 5 V.

Note that any cables connected to either the digital input or output must be less than 3 m in length in order to maintain EMC compliance.

Figure 4-7
The pin assignments for the digital input and output connectors

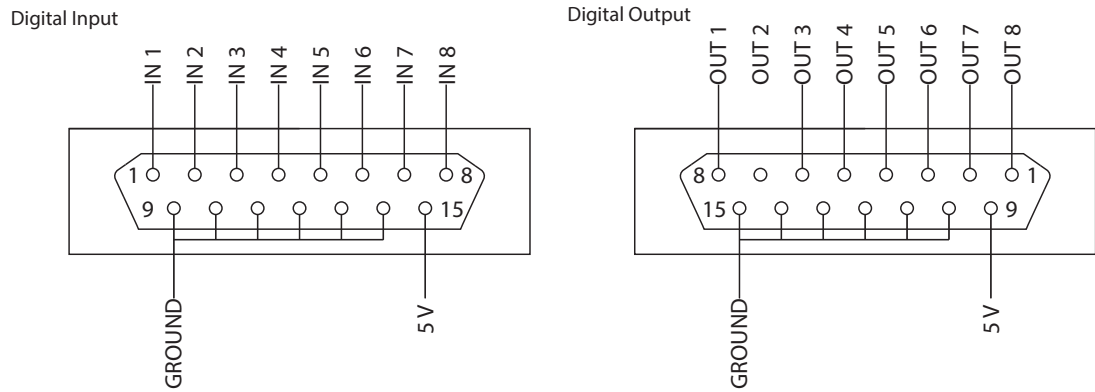

I²C Expansion Connector

The I²C port on the back panel of the PowerLab 2/26, 4/26 and 26T provides expansion support for ADInstruments front-ends. This port provides both power and control signals for these front-ends. The I²C bus has a daisy-chain structure that allows simple connection of additional front-ends to the system. A PowerLab can have as many front-ends connected to it as it has analog input connections. You should not attempt to run other external devices from the I²C port: it is designed for use only with ADInstruments front-ends. Only 50 mA maximum current can be provided through this bus, so it should not be used for third-party devices as they may draw more current.

Figure 4-8
The pin assignments for the I²C connector

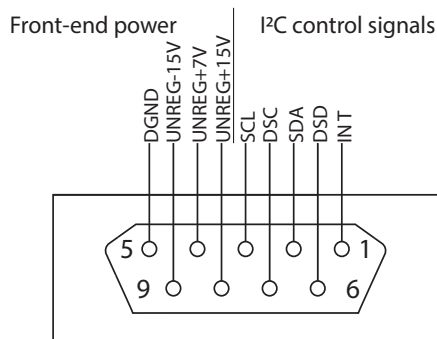
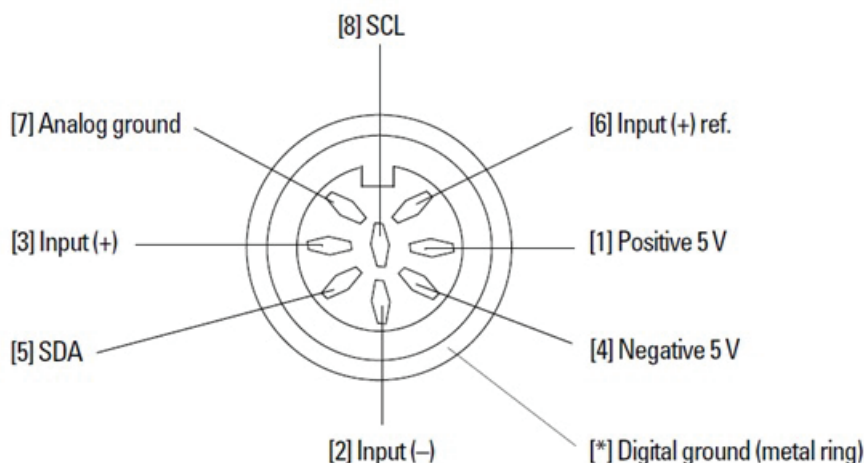

Figure 4-9

The pin assignments for the analog inputs



Input Connectors

The input connectors (Figure A-8) of the PowerLab 15T, 2/26, 4/26 and 26T are 8-pin DIN connectors. They allow the connection of ADInstruments pods — small, low-cost signal conditioners for specific tasks, for use with precalibrated transducers. Transducers designed for direct connection can be provided with power and control through the connectors.

The PowerLab 2/26 and 4/26 also have BNC input connectors as well as the 8-pin DIN connectors.

Note that with the PowerLab 26T:

- ADInstruments front-ends, such as the FE221 Bridge Amp, can be used with inputs 1 and 2 (but not inputs 3 or 4) by connecting them with the DIN-to-BNC adaptor.
- When an ADInstruments pod is connected to either input 3 or 4, the corresponding Bio Amp input is turned off.

USB Connection

PowerLabs have a USB 2.0 port, and connect to a computer with USB ports or a PCI USB card installed, allowing high data transfer rates to USB 2.0-compliant computers (slower transfer to USB 1.1-compliant computers).

The signal must be transmitted in a certain time; in practical terms this means cables between any USB devices, including hubs, must be no more than 5 meters (16 feet) in length, and with hubs in the chain, devices must be no more than 30 meters (98 feet) from the computer. For proper use and reliable results, the PowerLab needs a high-speed connection. Your PowerLab is supplied with a high-speed USB cable. If you replace the USB cable, buy a high-speed cable (fully shielded, twisted-pair and standard USB connections: a Type A plug at one end and a Type B plug at the other).

When devices that transfer a lot of information, such as scanners and video cameras, are connected to the same USB tree and are used at the same time as a PowerLab, sampling rates may be limited considerably (in LabChart) . All computers (both PC and Macintosh) usually have several independent USB ports. Using these, rather than a hub, to connect multiple devices will avoid them competing for capacity (bandwidth).

You can safely turn on or off, or disconnect or reconnect, a USB-connected PowerLab while the computer remains on, as long as the application program is off when you do it.

Earthing and Ground Loop Noise

The prime function of earthing is safety, that is, protection against fatal electrocution. Safety concerns should always override concerns about signal quality. Secondary functions of earthing are to provide a reference potential for the electrical equipment and to mitigate against interference.

The earthing (grounding) stud provided on the back panel of the PowerLab is a potential equalization post and is compatible with the DIN 42801 standard. It is directly connected to the earth pin of the power socket and the PowerLab chassis. The earthing stud can be used where other electronic equipment is connected to the PowerLab, and where conductive shields are used to reduce radiative electrical pick-up. Connection to the stud provides a common earth for all linked devices and shields, to reduce ground-loops.

The earthing stud can also be used where a suitable ground connection is not provided with the mains supply by connecting the stud to an earthed metal infra-structure, such as a metal stake driven into the ground, or metal water piping. This may also be required in laboratories where safety standards require additional grounding protection when equipment is connected to human subjects. Always observe the relevant safety standards and instructions.

Note that magnetically-induced interference in the recorded signal can be reduced by minimizing the loop area of signal cables, for example by twisting them together, or by moving power supplies away from sensitive equipment. This can reduce the inductive pick-up of mains frequency fields. Please consult a good text for further discussion of noise reduction

Specifications

Analog Inputs

Number of input channels:	15T:	2 DIN
	2/26:	2 DIN and BNC
	4/26:	4 DIN and BNC
	26T:	4 DIN
Configuration:	DIN are single-ended or differential BNC are single-ended	
Amplification ranges:	<i>Range</i>	<i>Resolution</i>
	± 10 V	313 µV
	± 5 V	156 µV
	± 2 V	62 µV
	± 1 V	31 µV
	± 500 mV	15 µV
	± 200 mV	6 µV
	± 50 mV	1.5 µV
	± 20 mV	625 nV
Maximum input over-voltage:	± 15 V	
Input impedance:	15T:	1 MΩ // 150 pF
	2/26:	1 MΩ // 150 pF
	4/26:	1 MΩ // 150 pF (Inputs 1 & 2) 1 MΩ // 200 pF (Inputs 3 & 4)
	26T:	1 MΩ // 150 pF (Inputs 1 & 2) 1 MΩ // 150 pF (Inputs 3 & 4)
Input Coupling:	DC or 0.15 Hz (software selectable)	
-3dB bandwidth:	49 kHz	
DC drift:	Software corrected	
CMRR:	> 105 dB at a gain of 100	
Interchannel crosstalk:	> 90 dB	

Signal-noise ratio:	> 100 dB (± 10 V range)
Accuracy error:	Less than 0.2 %
Non-linearity (max):	0.1 %
Filters - Low pass:	1, 2, 5, 10, 20, 50, 100, 200, 500, 1000, 2000 Hz and Anti-alias
- Notch:	Mains

POD Connectors (DIN)

General features:	Combined power, I ² C and single-ended or differential analog input signals on one connector, support SmartPod transducers, etc.
Supply voltage:	± 5 V regulated
Maximum current:	50 mA per pod connector
Communications:	2-wire I ² C
Signal input:	Positive and negative analog inputs and analog return
Connector type:	8-pin DIN with metal surrounds

Sampling

ADC sampling:	Simultaneous across channels
ADC resolution:	24-bits (16-bits resultant)
ADC linearity:	± 0.0006 % FSR (INL)
Available sampling rates:	100 000 samples/s down to 10 min/sample

Bio Amp Input- Inputs 3 & 4 (PowerLab 15T & 26T)

Number of channels:	2
Input configuration:	Differential with common isolated ground

Amplification ranges:	<i>Range</i>	<i>Resolution</i>
	± 20 mV	625 nV
	± 10 mV	313 nV
	± 5 mV	156 nV
	± 2 mV	62 nV
	± 1 mV	31 nV
	± 500 μ V	15 nV
	± 200 μ V	6 nV
	± 100 μ V	3 nV
Gain accuracy:	1 %	
Non-linearity:	1 %	
Noise:	$< 1 \mu\text{V}_{\text{rms}}$ (0.5 - 2 kHz)	
Maximum input over-voltage:	± 5 V	
Input leakage current:	$< 4 \mu\text{A}_{\text{rms}}$ @ 120 V, 60 Hz $< 4 \mu\text{A}_{\text{rms}}$ @ 240 V, 50 Hz	
DC blocking:	± 0.3 V	
Baseline restoration:	Automatic or user-controlled	
Input impedance:	100 M Ω to isolated ground (~500 pF per lead) using supplied Bio Amp subject cable and lead wires	
Safety:	IEC60601-1 approval	
Isolation rating:	4000 V AC _{rms} (1 minute)	
IMRR:	130 dB	
CMRR:	110 dB	
Filters - High pass:	Single pole 0.5 Hz and 10 Hz	
- Low pass	10, 20, 50, 100, 250, 500, 1000, 2000 Hz	
- Notch	Mains	
Audio output (26T only):	Stereo output socket supplying an analog audio signal from both bio amp channels. Suitable for earphones, headphones and most externally powered speakers. Output is 300 mV at full scale	

Output Amplifier

Output configuration:	2 Outputs- Complementary
Output resolution:	16-bit
Maximum output current:	20 mA
Accuracy error:	Less than 0.25
Linearity error:	± 0.5 LSB (INL) (typical) ± 0.5 LSB (DNL) (typical)
Output ranges:	± 10 V ± 5 V ± 2 V ± 1 V ± 500 mV ± 200 mV
Output slew rate:	2.3 V/ μ s
Settling time (G=1, 10 V step):	5 μ s
Output impedance:	0.001 Ω

Isolated Stimulator Output (PowerLab 15T & 26T)

Output configuration:	Constant-current stimulator with hardware limited repetition rate
Isolation rating:	4000 V _{rms} to ground as per IEC60601-1 2000 V _{rms} to Bio Amp inputs
Pulse duration:	50 - 200 μ s (software selectable)
Compliance voltage:	100 - 110 V typical
Output current:	Software selectable, but hardware limited to a maximum of 1000 Hz and 200 μ s for safety
Safety indicators:	Green and yellow indicators. Green flash indicates delivery of a valid stimulus. Concurrent green and yellow flash indicates an out-of-compliance condition.
Safety switch:	Provides physical disconnection of the stimulator from the subject.

External Trigger (not on PowerLab 15T)

Trigger mode:	TTL level or contact closure, software selectable
Trigger threshold:	+1.3 V (rising edge), +1.1 V (falling edge)
Hysteresis:	0.3 V

Input load: HCMOS

Maximum input over-voltage: ± 12 V

Minimum event time: 3 μ s

Expansion Ports (not on PowerLab 15T)

I2C expansion port: Power and control bus for front-end units. Supports a number of front-ends equal to the number of PowerLab analog inputs. Interface communications rate of up to 10 Kbits/s.

Digital ports (26T only)

- Output: 8 independent lines, TTL output level (8 mA maximum load per line)

- Input: 8 independent lines, TTL input level, threshold 1.2 V, 10 k Ω input impedance, 5V maximum

Microprocessor and Data Communication

CPU: Digital Signal Processor – Freescale DSP56858

Data communication: Hi-speed USB 2.0 (max of 480 Mb/s transfer) compatible with USB 1.1 hosts.

Physical Configuration

Dimensions (h \times w \times d): 65 mm \times 200 mm \times 250 mm (2.56" \times 7.9" \times 9.8")

Weight: 1.7 kg (3 lb 12 oz)

Operating Requirements

Operating voltage range: 95–264 V AC, 47–63 Hz

Rated Power: 35 VA

Power requirements: ~ 10 W

Operating conditions: 5–35 $^{\circ}$ C, 0–90% humidity (non-condensing)

Safety

Earth leakage current: Less than 300 μ A

Safety device compatibility: 10 mA

Transport and

Storage conditions: 0–40 $^{\circ}$ C, 0–95% humidity (non-condensing)

Equipment: The PowerLab must be connected to safety earth via the power supply cable to ensure electrical safety.

Regulatory Information

Safety:	Complies with IEC 60601-1:2012 (tested by TÜV SÜD PSB, Singapore)
EMC:	Complies with IEC 60601-1-2:2014 (tested by EMC Technologies, Sydney, Australia)
Operation:	Continuous
Body protection rating (Applied parts only):	 (BF)
Unsuitable uses:	Do not use in the presence of flammable anaesthetic - air mixtures. Avoid operating near high voltage, RF or strong magnetic fields that may cause interference.
Method of Disposal:	Forward to recycling centre or return to manufacturer.

ADInstruments reserves the right to alter these specifications at any time.

<i>Immunity test</i>	<i>IEC 60601 test level</i>	<i>Compliance level</i>	<i>Electromagnetic environment guidance</i>
Conducted RF IEC 61000-4-6	3 Vrms 150 kHz to 80 MHz	3 V	Recommended separation distance (see TableB-2 p. 50)
Radiated RF IEC 61000-4-3	3 V/m 80 MHz to 2.7 GHz	3 V/m	Recommended separation distance (see TableB-2 p. 50)
Electrostatic discharge IEC61000-4-2	±8 kV contact ±15 kV air	±4 kV contact ±8 kV air	Floors should be wood, concrete or ceramic tile. If floors are covered with synthetic material, the relative humidity should be at least 30%.
Electrical fast transient/burst IEC61000-4-4	±2 kV for power supply lines	±2 kV for power supply lines	Mains power quality should be that of a typical commercial or hospital environment.
Surge IEC 61000-4-5	±0.5, 1 kV line-line ±0.5, 1, 2 kV line-ground	±0.5, 1 kV line-line ±0.5, 1, 2 kV line-ground	Mains power quality should be that of a typical commercial or hospital environment.
Voltage dips, short interruptions and voltage variations on power supply input lines IEC61000-4-11	<5% UT (>95 % dip in UT) for 0.5 cycle 40% UT (60% dip in UT) for 5 cycles 70% UT (30% dip in UT) for 25 cycles <5% UT (>95% dip in UT) for 5 sec	<5% UT (>95% dip in UT) for 0.5 cycle 40% UT (60% dip in UT) for 5 cycles 70% UT (30% dip in UT) for 25 cycles	Mains power quality should be that of a typical commercial or hospital environment. If the user of the devices require continued operation during power mains interruptions, it is recommended that the devices be powered from an uninterruptible power supply or a battery.
Power frequency (50/60Hz) magnetic field IEC 61000-4-8	3 A/m	3 A/m	Power frequency magnetic fields should be at levels characteristic of a typical location in a typical commercial or hospital environment.

Table 4-1 Immunity Test compliance

Electromagnetic Compatibility

The PL15T02 PowerLab 15T, PL2602 PowerLab 2/26, PL2604 PowerLab 4/26 and PL26T04 PowerLab 26T (the devices) have been tested to comply with IEC 60601-1-2:2014. The relevant basic EMC standards are IEC 61000-4-2, IEC 61000-4-3, IEC 61000-4-6, IEC 61000-4-8, IEC 61000-4-11 and CISPR 11.

Emissions

- The devices are suitable for use in all establishments other than domestic and those directly connected to the public low-voltage power supply network that supplies buildings used for domestic purposes. There may be potential difficulties in ensuring electromagnetic compatibility in other environments, due to conducted as well as radiated disturbances.

Immunity

- Mains power quality should be that of a typical commercial or hospital environment. If the user of the device requires continued operation during power mains interruptions, it is recommended that the device be powered from an uninterruptible power supply or a battery.
- Power frequency magnetic fields should be at levels characteristic of a typical location in a typical commercial or hospital environment.
- Floors should be wood, concrete or ceramic tile. If floors are covered with synthetic material, the relative humidity should be at least 30%.

Separation Distances

- The devices are intended for use in an electromagnetic environment in which radiated RF disturbances are controlled.
- Portable and mobile RF communications equipment should be used no closer to any part of the device, including cables, than the recommended separation distance in the table below.
- Field strengths from fixed RF transmitters, as determined by an electromagnetic site survey, should be less than the compliance level in each frequency range.

Rated maximum output power of transmitter, P	Separation distance	
	150 kHz to 800 MHz $d = 1.17\sqrt{P}$	800 MHz to 2.7 GHz $d = 2.33\sqrt{P}$
0.01 W	0.1 m	0.2 m
0.1 W	0.4 m	0.7 m
1 W	1.2 m	2.3 m
10 W	3.7 m	7.4 m
100 W	11.7 m	23.4 m



Troubleshooting

This section describes most of the common problems that can occur when using your PowerLab unit. It covers how these problems are caused and what you can do to alleviate them. If the solutions here do not work, earlier chapters or your software guide may contain possible remedies. If none of the solutions here or elsewhere appears to help, then consult your ADInstruments distributor.

Most of the problems that users encounter are connection problems and can usually be fixed by checking connections and starting up the hardware and software again. Very rarely will there be a problem with the PowerLab itself.

Problems

The Power Indicator light is off, even though the Power cable is plugged into the mains and is turned on

This may be because a fuse has blown.

- However, first check and see if the switch on the Rear panel has been turned on. If not, turn it on and then check if the Power indicator light turns on.
- If it doesn't, inspect the replaceable fuses and replace if necessary. Refer to section 'Checking and replacing fuses' in Chapter 2. If this still doesn't fix the problem, contact your local technical support office.

The fuse drawer may have been dislodged in handling or transport. Ensure it is seated correctly by pushing firmly against it with a finger.

The Status indicators fail to light up when the software is started, or the device commands do not appear where they should

The I2C cable or one or more BNC-to-BNC cables from the front-end to the PowerLab are not connected, have been connected incorrectly (to the wrong input or output, for instance), or are loose.

- Turn everything off. Check to see that all cables are firmly seated and screwed in. BNC cables from the front end must be connected to a positive input on the PowerLab. Make

sure the input is the same channel from which you expect to use the front end in the software. Start up again to see if this has fixed the problem.

You are using an early version of the software. You must be using version 7 or higher of LabChart.

- Upgrade to the latest version of the software. Contact your ADInstruments distributor for information.

The BNC or I2C cable is faulty

- Replace the cable and try again. Immediately label all cables proved faulty so that you don't use them again by accident.

The PowerLab, or a portion of it, is faulty

- This is the least likely event. Contact your ADInstruments distributor to arrange for repairs

On starting up the software, an alert indicates that there is a problem with the PowerLab or driver

The correct drivers are not installed on your computer (LabChart has them built in).

- Reinstall the software.

You are using an early version of the software. You must be using version 7 or higher of LabChart.

- Upgrade to the latest version of the software. Contact your ADInstruments distributor for information.

The BNC or I2C cable is faulty

- Replace the cable and try again. Immediately label all cables proved faulty so that you don't use them again by accident.

The PowerLab, or a portion of it, is faulty

- This is the least likely event. Contact your ADInstruments distributor to arrange for repairs

The Stimulator Status indicator shows yellow

This means that the Stimulator is out of compliance (OOC). You could be attempting stimulation while the output safety switch is turned off (in the down position).

- Turn the safety switch on (move to the up position).

The impedance of the tissue could be too high for the Stimulator to supply constant current at the level requested, or there is an inadequate electrical connection to the subject.

- Reduce the output current amplitude.
- Check the connections for proper contact and try again. Ensure the connection is not dry (apply electrode cream) and that the leads are properly connected.

The Bio Amp trace will not zero properly when adjusting high-pass filtering

This Bio Amp is receiving signals at a level that has saturated the input amplifier, resulting in a large offset. This is normally due to poor contact between the electrodes and the subject.

- Check the connections for proper contact and try again.

The Bio Amp signal appears to display a constant amplitude oscillation

Frequency interference from power lines can become superimposed on the biological signal being measured.

- You can use the internal notch filter in the Bio Amp to remove the excessive line voltage frequency interference (use the checkbox in the Bio Amplifier dialog box).

If you are using cables and leads that were not supplied with your PowerLab, they may be unshielded or of low quality

- Check to make sure that you are using high-quality shielded cables and high-quality leads. Only the supplied cables and leads should really be used.

The Bio Amp signal is noisy at lower ranges

This is probably the amplified noise from the electrodes, not a fault as such. There is, in addition, noise that cannot be avoided by any amplifier (called 'thermal' or 'Johnson' noise).

- Set the low-pass filter to remove the noise. (But be careful, since important components of the signal could also be attenuated).

This could be due to an electrically noisy environment, particularly if there is some equipment that produces a radio frequency that interacts with the Bio Amp modulator, giving a heterodyne effect

- Turn off pieces of unnecessary equipment to try and isolate the cause, then either leave the equipment off, or, if possible, move the subject or equipment outside the area of any interfering field.
- At the lowest ranges you may have to shield, shorten or even replace the Bio Amp leads, since they will tend to act as radio receptors.

The Bio Amp signal appears to be unusual, very weak, clipped or distorted in some way

This may be a problem of technique: the sampling rate, range or filter settings may be inappropriate for the signal you are recording.

- Make sure the settings are appropriate for the expected signal.

You may be using the wrong Bio Amp cable. The 3-lead Bio Amp cable used with the single Bio Amp has a different pin arrangement and cannot be used with the Dual Bio Amp/ Stimulator front-end.

- Use the correct, supplied 5-lead Bio Amp cable.

PowerLab LED Error Sequences

Table 5.1 below lists all the system, error and fault messages that are generated during PowerLab operation.

Errors are displayed by one Yellow LED flash, followed by a number of SHORT/LONG Red Flashes which are specified for each error in the 'Red Light Sequence' of Table 5.1.

The response to fatal errors is to display a red flashing status light. The light will repeat a yellow flash followed by a number of red flashes. If there are 1 to 4 red flashes, they correspond to errors 1 to 4. If there are five red flashes, they will consist of long and short flashes corresponding to the binary representation of the absolute value of the five-bit error code.

For example, Abs (-13) => 01101 => short, long, long, short, long.

In this state the PowerLab will not respond to any communications.

Table 5.1

Error No.	Red Light Sequence	Meaning	F a t a l / Non-Fatal	Error Name
-2	LNG, LNG	RAM test failed	Fatal	eRAMFailure
-4	LNG, LNG, LNG, LNG	ROM check sum was wrong	Fatal	eROMCheckBad
-7	SHRT, SHRT, LNG, LNG, LNG	Required resource missing	Non-Fatal	eRsrcMissing
-8	SHRT, LNG, SHRT, SHRT, SHRT	Real-time clock won't reset or increment	Non-Fatal	eClkBad
-11	SHRT, LNG, SHRT, LNG, LNG	Command FIFO flags don't read correctly	Non-Fatal	eCmdFIFO
-12	SHRT, LNG, LNG, SHRT, SHRT	ADC FIFO flags don't read correctly	Non-Fatal	eADCFIFO
-13	SHRT, LNG, LNG, SHRT, LNG	DAC FIFO flags don't read correctly	Non-Fatal	eDACFIFO
-14	SHRT, LNG, LNG, LNG, SHRT	DAC state machine won't run	Non-Fatal	eDACSysBad
-15	SHRT, LNG, LNG, LNG, LNG	ADC state machine won't run	Non-Fatal	eADCTimeOut
-16	LNG, SHRT, SHRT, SHRT, SHRT	ADC bad zero: p == value read	Non-Fatal	eADCZero
-17	LNG, SHRT, SHRT, SHRT, SHRT	EEROM wouldn't read	Non-Fatal	eEEROMBad
-18	LNG, SHRT, SHRT, LNG, SHRT	ADC FIFO capacity/speed tests failed	Non-Fatal	eADCSysBad
-30	LNG, LNG, LNG, LNG, SHRT	ADC won't read consistently	Non-Fatal	eChanNoisy



Glossary

AC coupling. A filter option. When AC coupling is chosen, a 0.1 Hz highpass filter before the first amplification stage removes DC and frequency components below 0.1 Hz. This removes slowly changing baselines.

ADC (analog-to-digital converter). A device that converts analog information into some corresponding digital voltage or current.

amplitude. The maximum vertical distance of a periodic wave from the zero or mean position about which the wave oscillates.

analog. Varying smoothly and continuously over a range. An analog signal varies continuously over time, rather than changing in discrete steps.

analog input. This refers to the connectors on the front of the PowerLab marked 'Input'. These inputs are designed to accept up to ± 10 volts. Inputs can be either single-sided or differential (the latter only in the case of the pod connectors).

analog output. This refers to the connectors on the front of the PowerLab marked 'Output'. The analog output provides a software-controlled variable output (± 10 V) that can be used with applications either directly as a stimulator, or to control peripheral devices. Not for use with human subjects.

analysis. When the PowerLab is not physically connected to the computer, then ADInstruments software can be used to analyze and manipulate existing files if the analysis option is chosen.

Applied Part. A part which necessarily comes into physical contact with the subject during normal use

BNC (bayonet nut connector). A type of cable or connector; a BNC-to-BNC cable connects two BNC connectors.

bridge transducer. A type of transducer using a Wheatstone bridge circuit. In its basic form, the bridge consists of four two-terminal elements (usually strain gauges) connected to form a quadrilateral. An excitation source is connected across one diagonal, and the transducer output is taken across the other.

bus. A data-carrying electrical pathway (cables and connectors).

connector. A plug, socket, jack or port used to connect one electronic device to another (via a cable): a PowerLab to a computer, say.

CPU (central processing unit). A hardware device that performs logical and arithmetical operations on data as specified in the instructions: the heart of most computers.

DAC (digital-to-analog converter). A device that converts digital information into some corresponding analog voltage or current.

DC offset. The amount of DC (direct current) voltage present at the output of an amplifier when zero voltage is applied to the input; or the amount of DC voltage present in a transducer in its equilibrium state.

differential input. Input using both positive and negative inputs on a PowerLab. The recorded signal is the difference between the positive and negative input voltages: if both were fed exactly the same signal, zero would result. Can reduce the noise from long leads.

DIN (Deutsche Industrie Norm). A type of cable or connector; there are various sorts with different numbers of pins.

envelope form. The overall shape of a signal, outlined by the minimum and maximum recorded values. Often used to display quickly changing signals.

excitation voltage. The voltage supplied to a bridge circuit from which the transducer output signal is derived. Manipulating the transducer changes the measurement elements of the bridge circuit, producing a change in its output voltage.

external trigger. The input connector on the front of the PowerLab marked 'Trigger'. This lets you start recording from an external source. The trigger level (the voltage needed to have an effect) depends on the hardware and cannot be changed. Recording can also be triggered by contact closure, if this is set up in the software.

filter. An electronic device or a program that alters data in accordance with specific criteria. Filters in hardware and software can be used to reduce or to eliminate electronic noise or drift from data readings.

frequency. The number of complete cycles per second of a waveform. Frequency is usually expressed in hertz: Hz (cycles per second), kilohertz: kHz (thousands of cycles per second), or megahertz: MHz (millions of cycles per second).

frequency response. The bandwidth in which a circuit passes a signal without too much attenuation. A low-pass filter's frequency response is the frequency where the output voltage becomes 0.707 ($1/\sqrt{2}$) of the input voltage or has been attenuated by 3 decibels. If a low-pass filter has a frequency response of 200 Hz, say, then the signal is effectively unattenuated up to 150 Hz, and is 0.707 of the original value at 200 Hz.

front-end. An ancillary device that extends PowerLab capabilities, providing additional signal conditioning and features for specialized work. Front-ends are recognized automatically by the PowerLab system and seamlessly integrated into its applications, operating under full software control.

gain. The amount of amplification of a signal.

half-bridge transducer. A bridge transducer only using half of the full-bridge circuit. It consists of two elements of equal value with an excitation voltage applied across them. The output of the transducer is taken at the junction of the two elements.

Hertz (Hz). The unit of frequency of vibration or oscillation, defined as the number of cycles per second. For example, the minimum sampling rate for a human ECG experiment should be 400 Hz (400 samples/s).

high-pass filter (HPF). A filter that passes high-frequency signals, but filters low ones, by blocking DC voltages and attenuating frequencies below a certain value (the cut-off, or -3 dB, frequency).

I²C ('eye-squared-sea'). This connection is used by the PowerLab to control front-ends. It provides power and communication using a 4-wire serial bus (two wires for standard I²C and two control lines).

IEC. International Electrotechnical Commission.

IEC60601-1. An IEC standard applicable to medical devices. Equipment compliant with this standard gives a high degree of protection from electrical and other hazards.

LabChart. An ADInstruments software application that emulates a multichannel chart recorder, with other powerful options. (Macintosh and Windows versions differ slightly.)

Lt. An ADInstruments cloud based application for teaching that integrates an experiment protocol, real-time data acquisition, analysis and reporting as interactive pages in a web browser.

low-pass filter (LPF). A filter that passes low-frequency signals and DC voltages, but filters high ones, attenuating frequencies above a certain value (the cut-off, or -3 dB, frequency).

TTL (transistor-transistor logic). A family of integrated circuits (ICs) with bipolar circuit logic, used in computers and related devices.

TTL is also a standard for interconnecting such ICs, defining the voltages used to represent logical zeroes and ones (binary 0 and 1).

USB. Universal Serial Bus.

waveform. The shape of a wave; a graph of a wave's amplitude over time.