

\$2.00

AUDIO MAGAZINE PRESENTS THE
PROFESSIONAL
AUDIO
BUYERS GUIDE



Your Handy Guide to Professional Recording and Studio Equipment

This compilation of manufacturers' literature and the AES Convention issue of AUDIO is intended to serve as a convenient reference guide to professional and studio equipment, and will enable you to examine the features of some of the newest products in the audio industry without the cumbersome handling of loose, separate sheets of literature. Catalog material is bound with the magazine for your convenience, and is distributed at the AES exhibit to anyone attending the Convention.

More detailed information on other products of the manufacturers whose literature is included herein or from the advertisers in AUDIO may be obtained by using the "Reader Service Card" which is a part of every issue of the magazine.

Enjoy yourself at the Convention and be sure to see all of the exhibits. Be sure to visit us at our booth.

the authoritative magazine about high fidelity

AUDIO

134 NORTH THIRTEENTH STREET
PHILADELPHIA, PENNSYLVANIA 19107

AUDIO ENGINEERING SOCIETY

The Audio Engineering Society welcomes everyone associated with audio -- either professionally or as aspirants to the role of practitioners in the art and science of audio engineering. This Convention and exhibit of equipment marks the twentieth anniversary of the Society, and those with a strong interest in audio are invited to apply for membership.

We hope you will enjoy the exhibits and that you will find the many technical sessions interesting and rewarding.

Leo L. Beranek
President, AES.





Brüel & Kjær offers you a complete range of precision instruments for

MEASUREMENT ANALYSIS RECORDING

not only single INSTRUMENTS
but COMPLETE SYSTEMS:

The "blocks" fit together to form systems ranging from set-ups for relatively simple problems to the most sophisticated set-up for automatic frequency response recording, statistical distribution analysis, recording of directional characteristics etc.

This folder will help you to choose the right instrument combination to solve your measuring problem.

For further details see the B & K Short Catalogue which is available in 13 languages.

Cabinet System

Instruments with a 40 cm wide front plate are available with three different types of cabinets. To indicate which type of cabinet is desired, a letter, A, B or C should be added to the type number when ordering the instruments.

"A". Indicates that the instrument is delivered in a lightweight metal cabinet.

"B". Indicates that the A-version is covered with a mahogany cabinet with handles and lid for transportation. The mahogany cabinet is fitted to the "A" version as an extra protection for the instrument.

"C". Indicates that the A-version is inserted in a frame which allows it to be mounted directly into a 19" standard rack.





GENERATORS

SPECIAL EQUIPMENT FOR ACOUSTICAL AND VIBRATION RESEARCH

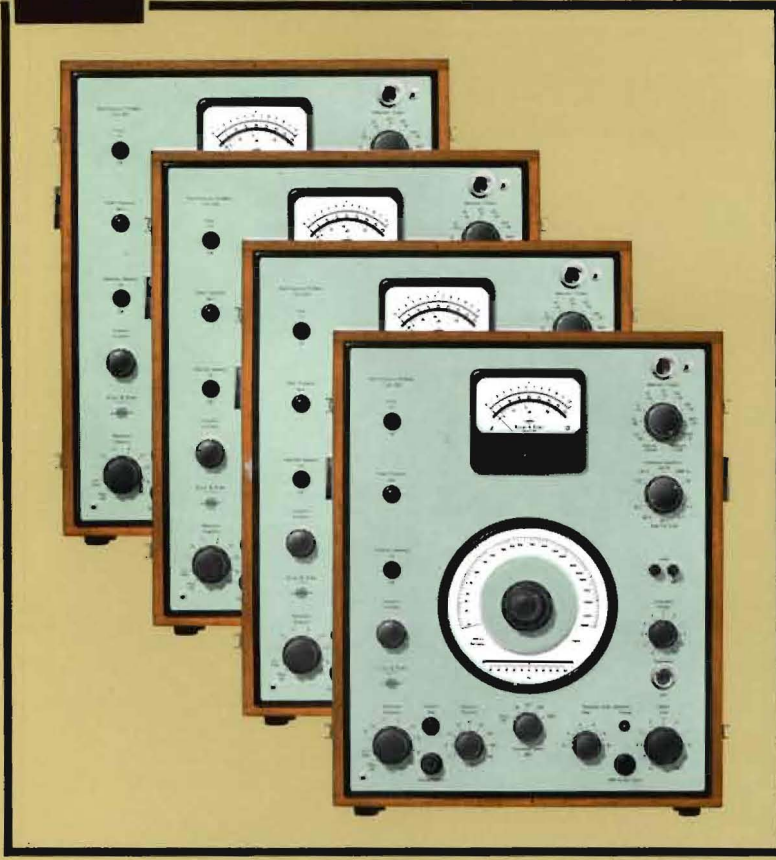

◀ **Beat Frequency Oscillators Type 1017, 1022 and 1013.** Frequency ranges 2 Hz-2 kHz, 20 Hz-20 kHz and 200 Hz-200 kHz.

Sine Random Generator Type 1024. Three types of output signals: Sine-wave, narrow bands of random noise and wide band random noise. Frequency range 20-20000 Hz.

Automatic Frequency response recording with all B & K Generators, when used with B & K Level Recorder.

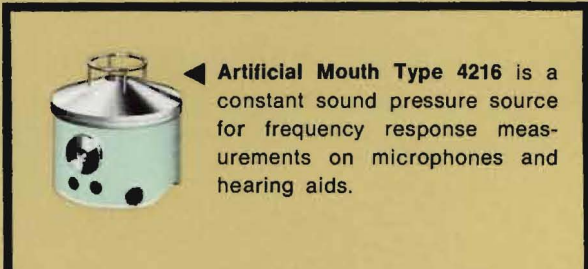

◀ **Artificial Mouth Type 4216** is a constant sound pressure source for frequency response measurements on microphones and hearing aids.

Standing Wave Apparatus Type 4002 for measurements of acoustic absorption coefficients and specific impedances of small samples.

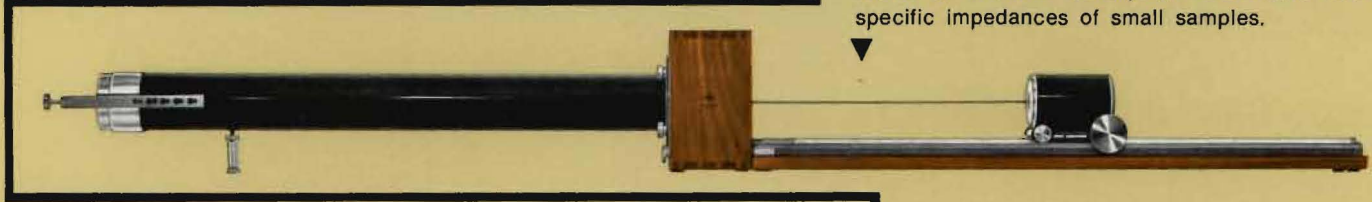

◀ **Random Noise Generator Type 1402.** Frequency range 20 Hz-20 kHz, 3 dB/octave network. Terminals for external filter.



◀ **Band-Pass Filter Set Type 1612.** 11 octave and 33 1/3-octave filters. Frequency range 20 Hz-40 kHz, with Type 1402 bands of random noise obtainable. Automatic scanning with Level Recorder Type 2305.



◀ **Tapping Machine Type 3204** for measurements of impact sound transmission in buildings.



▲ **Calibration Exciter Type 4290** for the high frequency calibration of accelerometers and other types of vibration pick-ups. Frequency range 50 Hz-30 kHz. Built-in accelerometer for control of table vibration level.



▼ **Pistonphone Type 4220** for calibration of sound measuring systems. 124 dB calibrated sound pressure level.



Instrumentation Guide for Sound and Vibration measurements

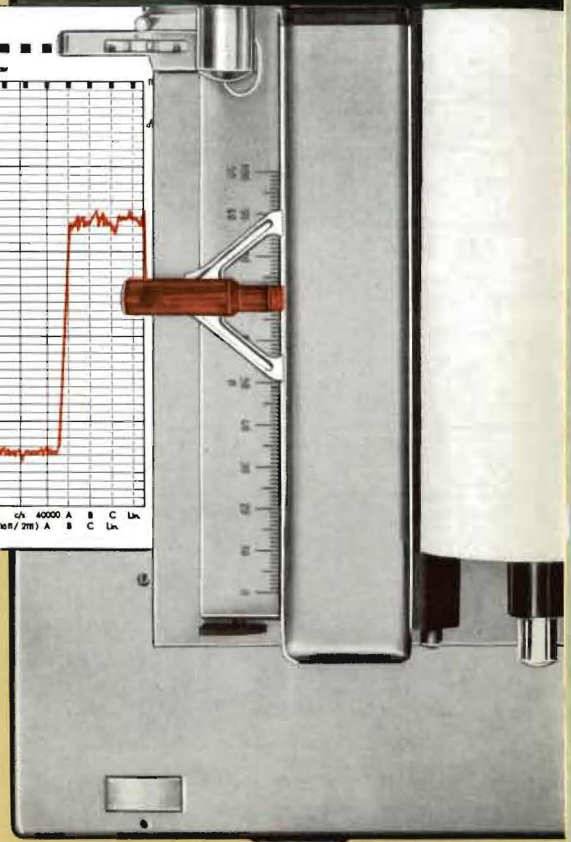
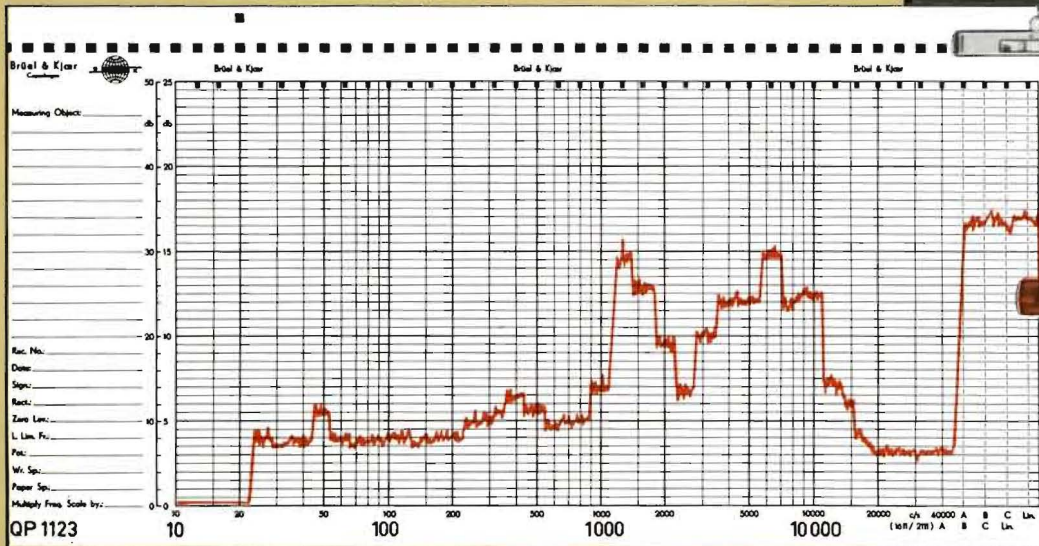
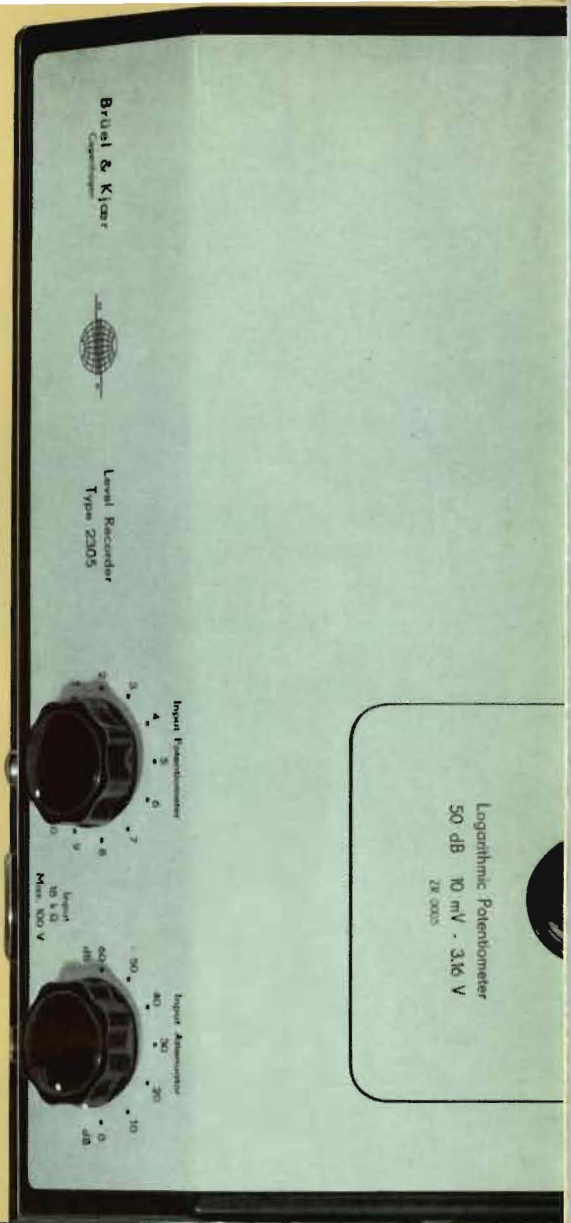
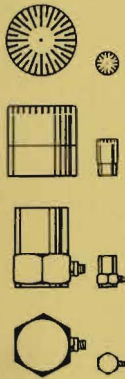

B & K INSTRUMENTS, INC.
Brüel & Kjær Precision Instruments

Main Office:
5111 West 164th Street
Cleveland, Ohio 44142
Tel.: 216 267-4800

West Coast Sales:
3787 Cahuenga Blvd.
No. Hollywood, California 91604
Tel.: 213 877-0961

BRÜEL & KJÆR



MICROPHONES ACCELEROMETERS

PREAMPLIFIERS

NOSE CONES WINDSCREEN CORRECTOR		MICROPHONE CARTRIDGES		ARTIFICIAL EAR ADAPTORS		CATHODE FOLLOWERS	
 UA 0082 1" 1/2" 1/4"		 4131-4132 1"		 1" → 1" 4152		 1" 2630	
 UA 0051 1"				 1" → 1" AO 0033		 1" 2612	
 UA 0055 1"		 4133-4134 1/2"		 1" & 1/2" → 1" UA 0039		 1" 2613	
 UA 0052 1/2"				 1/4" & 1/2" → 1/2" UA 0122		 1" 2617	
 UA 0056 1/2"		 4135-4136 1/4"		 1/4" & 1/2" → 1/2" UA 0123		 1/2" 2614	
 UA 0053 1/4"		 4138 1/8"		 1/4" → 1/2" UA 0035		 1/2" 2615	
				 1/8" → 1/2" UA 0036			
ACCELEROMETERS							
4312	4352			direct to Sound Level Meter or Cathode Followers			
4313	4353			PREAMPLIFIERS			
4314	4354						
4315	4355			 1606			
4316	4356			 2616 6 - 95 V =			
4320				 2623 28 V =			
Type nos. for accelerometer packages of 5.				INTEGRATOR			
Type nos. for accelerometer sets contain- ing one accelerometer with cable, magnet clamp, plug and fastening accessories.				 ZR 0020			



Precision Sound Level Meter Type 2203 fulfils the IEC and ASA Standards. Interchangeable condenser microphone. Terminals for external filters and recorders. With accelerometer and integrator ZR 0020 also suitable as vibration meter.

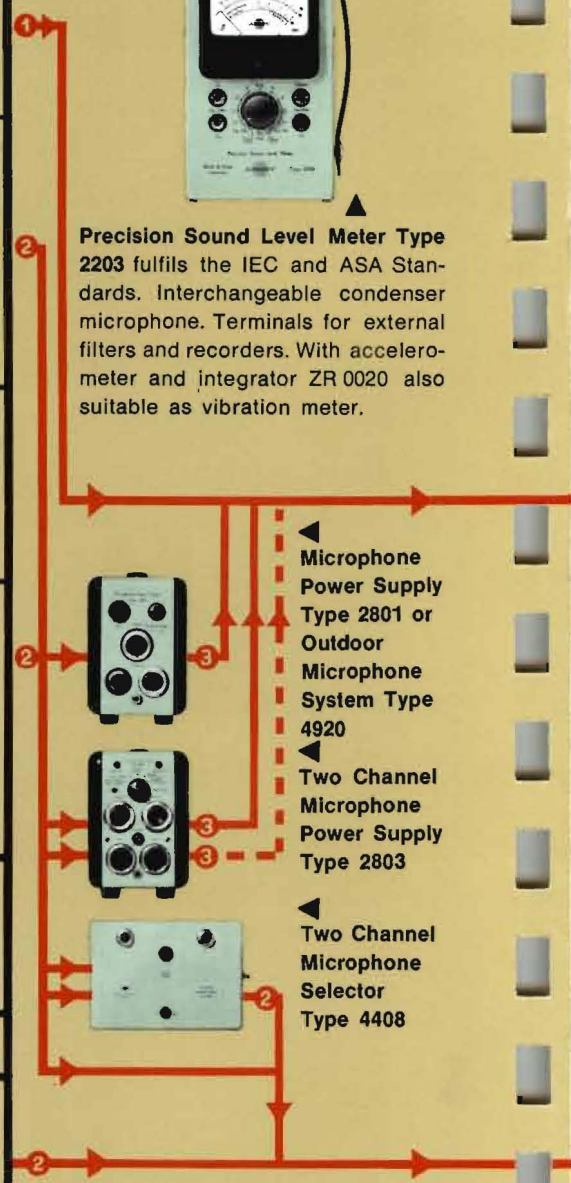

- Microphone Power Supply Type 2801 or Outdoor Microphone System Type 4920
- Two Channel Microphone Power Supply Type 2803
- Two Channel Microphone Selector Type 4408

- ① direct or Cable AO 0014/19/20 with Extension Connector JJ 0005
- ② direct or Cable AO 0027/28/29
- ③ two Core Cable or AO 0014/19/20

The FET Preamplifiers may be connected directly to any of the B & K Amplifiers, Voltmeters and Analyzers. The B & K Adaptor Plug Type JP 0028 is delivered with the Accelerometer Sets.

Mounts directly on Sound Level Meter Type 2203 or 1" Cathode Follower.



ANALYZERS

FILTERS



◀ **Octave Filter Set Type 1613** consists of 11 octave filters from 31.5 Hz–31.5 kHz. Built-in adjustable weighting.

AUDIO FREQUENCY ANALYZERS



◀ **Frequency Analyzer Type 2107.** Adjustable bandwidth from 6%–30%. Continuous sweeping from 20 Hz–20 kHz. Can be used direct as distortion meter. With B & K Level Recorder, direct recording of noise, vibration and other A.F. spectrograms.

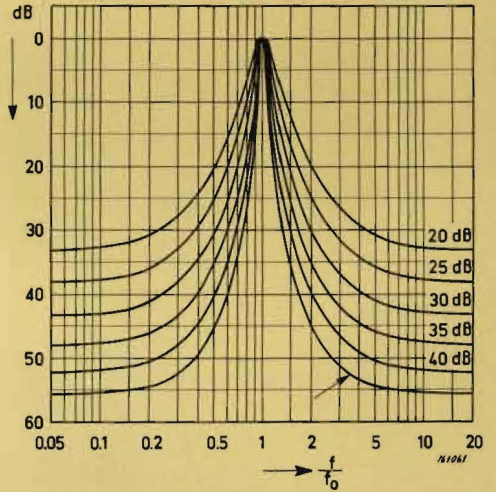

▶ **Audio Frequency Spectrometer Type 2112** incorporates 33 third octave and 11 full octave filters. 25 Hz–40 kHz. Extension filters 12.5, 16 and 20 Hz available. Automatic recording of noise, vibration and other A.F. spectrograms when used with B & K Level Recorder.



▶ **Microphone Amplifier Type 2603** used in connection with **Band-Pass Filter Set Type 1612** makes an audio frequency spectrometer with the same possibilities as Type 2112.



▶ The **Band-Pass Filter Set Type 1612** may also be connected as external filter to the frequency Analyzer Type 2107 for octave – 1/3 octave analysis or for high attenuation away from the pass band of 2107.

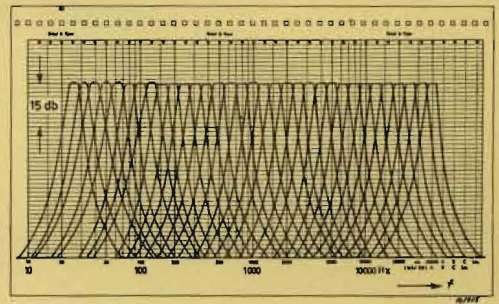

PRODUCTION CONTROL

▶ **Audio Frequency Response Tracer Type 4712** for production testing and inspection of amplifiers, gramophones, tape recorders, filters, loudspeakers, transmission lines, etc. in the frequency range from 20 Hz–20 kHz. 14", long-persistence screen. Y-amplifier with four dynamic ranges: 50 dB log., 25 dB log., 5 dB log. or linear. The horizontal deflection is determined by the frequency of the input signal. Used in conjunction with B.F.O. Type 1022 frequency sweeps are provided automatically with built-in motor drive.

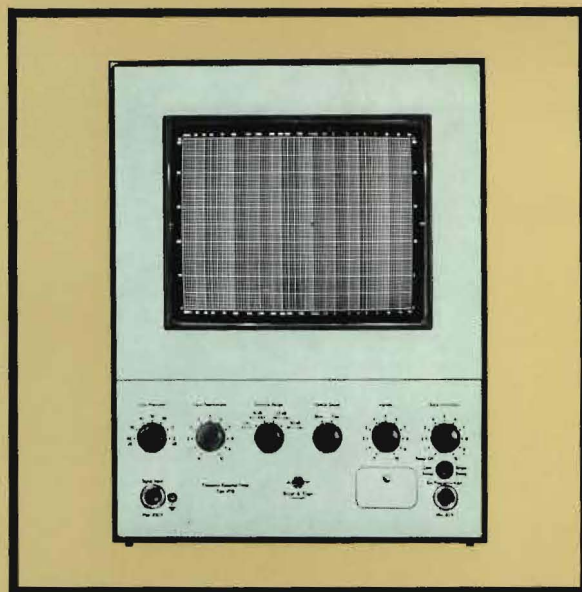

▶ **Hearing Aid Test Box Type 4212** is an anechoic chamber for measurements of the frequency response of all types of hearing aids and small microphones in the frequency range 150 Hz to 5 kHz. Built-in loudspeaker, regulating precision microphone, and artificial ear with 2-cm³ coupler specially designed for use both on hearing aids with built-in earphones and the conventional types. The Artificial Ear is in accordance with ASA-standard Z. 24.9. and the international IEC Recommendation.

▶ **Small Hearing Aid Test Box Type 4217** is an anechoic chamber acoustically similar to the 4212 Hearing Aid Test Box, however, with a built-in generator. It is designed to check the sensitivity and frequency response of hearing aids. The generator provides 15 fixed frequencies adjusted to equal sound pressure level in the range from 200 Hz to 5 kHz. Type 4217 should be used with a Sound Level Meter Type 2203 as indicator equipped with a 2 cm³ coupler. Power supply to replace batteries of Type 2203 is incorporated in the Test Box.

▶ **Noise Limit Indicator Type 2211** offers you a reliable quality control for mass production of, for example, vacuum cleaners, refrigerators, compressors, gearboxes etc. The acceptable noise spectrum is preset with the aid of 12 filters, each of which can be adjusted separately within a range of 45 dB. The instrument will immediately indicate the frequency bands in which the noise or vibration exceeds the preset level.

▶ **Noise Limit Indicator Type 2212** is based on the same principle as Type 2211, but contains input channels for 6 microphones to provide noise control at 6 positions as for instance around airports, in traffic control etc. Outputs for each channel for connection to warning systems, printers, or other automatic devices.

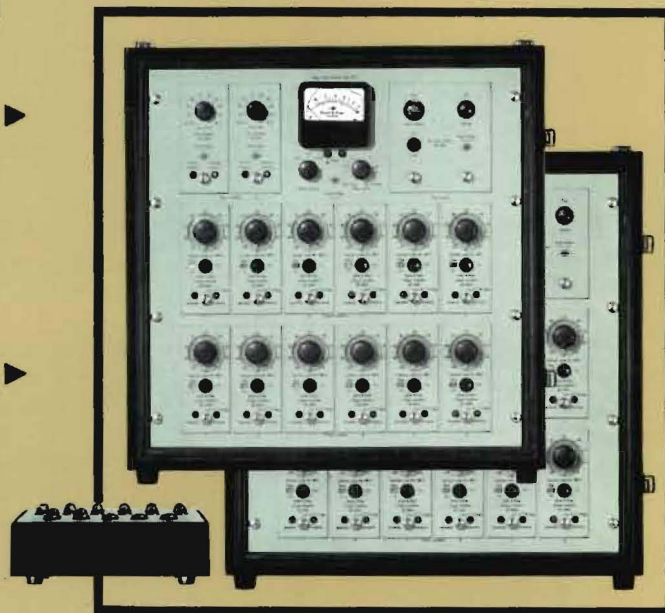

BRÜEL & KJÆR



LEVEL RECORDER

AO 0007

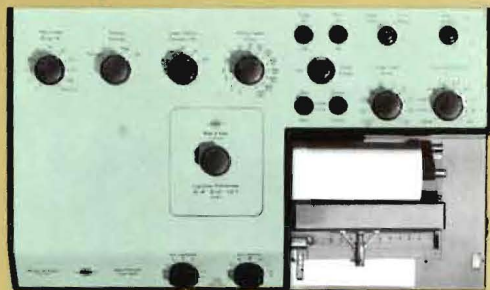
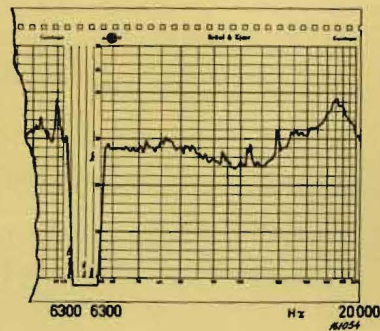
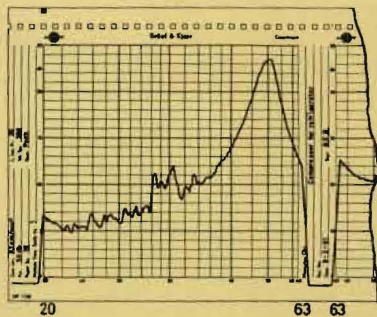

Level Recorder Type 2305. Records, for instance, the output level of sound level meters as a function of time, or the output level of the Brüel & Kjær analyzers or oscillators as a function of frequency. True RMS, average or peak indication. Dynamic range from 10 dB-75 dB.

AO 0014/19/20



Synchronizing arrangement for generators or analyzers.

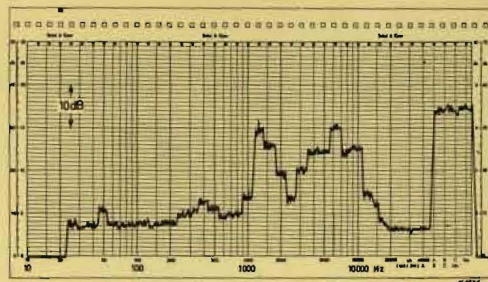

LEVEL RECORDER ACCESSORIES



▲ **Turntable Type 3921** for automatic recording of polar diagrams.

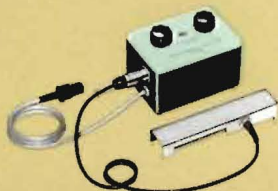

▲ **Analog Voltage Read-out Type ZR 0021.** Provides a DC output which is proportional to the logarithm of the RMS, peak or average value of the input signal to the level recorder.

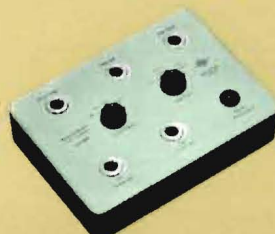

▲ **Response Test Unit Type 4409 and Pick-Up Test Records Type QR 2007, 2008 and 2009** for automatic testing of tape recorders and pick-ups.





AMPLIFIERS

LEVEL RECORDER

AO 0007

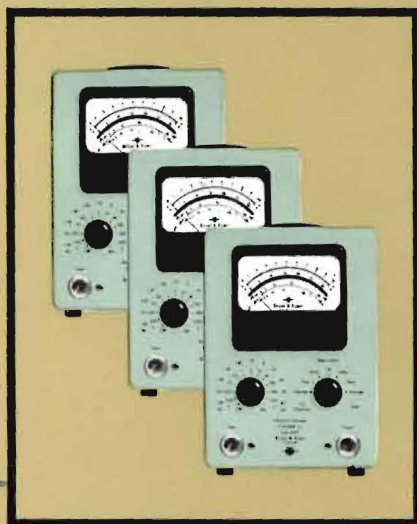

◀ **Random Noise Voltmeter Type 2417** for measurement of narrow band noise. Frequency range 2 Hz-20 kHz. Quasi RMS indication.

RMS Audio Voltmeter Type 2410. Frequency range 5 Hz-50 kHz. Quasi RMS indication.

Electronic Voltmeter Type 2409. Frequency range 2 Hz-200 kHz. True RMS, average or peak indication.

Level Recorder Type 2305. Records, for instance, the output level of sound level meters as a function of time, or the output level of the Brüel & Kjær analyzers or oscillators as a function of frequency. True RMS, average or peak indication. Dynamic range from -10 dB-75 dB.

AO 0014/19/20



◀ **Microphone Amplifiers Type 2603, and 2604.** True RMS, average or peak indication. Weighting curves for sound level measurements. Terminals for external filter. 2603: 2 Hz-40 kHz. 2604: 10 Hz-200 kHz.

Statistical Distribution Analyzer Type 4420 ▶ resolves the writing width of the level recorder in 12 class intervals. Gives digital display of the distribution of recorded levels.

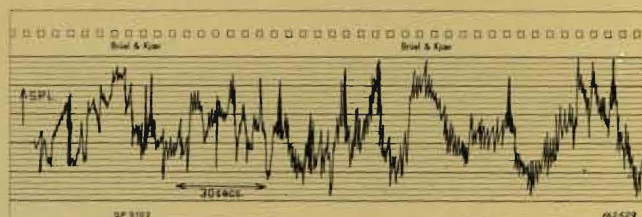
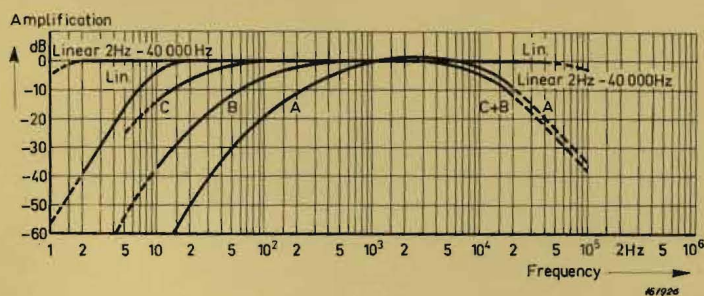



1/3-octave spectrum shapers

Features

- Thirty-three $\frac{1}{3}$ -octave, three-section filters meet U.S.A.S.I., ISO standards.
- 25 to 40,000 Hz center frequencies. Optional filters extend frequency range down to 12.5 Hz.
- Thirty-six vertical attenuators form a visual front panel configuration of the set-in spectrum shape.
- Memory bar assures fast and exact reproducibility of attenuator settings.
- Individual test point for each attenuator adjustment.
- Shaper has zero insertion loss and low output impedance.
- Single filter notching of approximately 30 dB.
- Roll-off attenuation of 40 dB per octave or better.
- Matched, continuously adjustable attenuators.
- One volt input and output levels are compatible with most signal conditioning amplifiers.

Uses

- Signal shaping of acoustical spectra.
- Simulation of hearing loss.
- Group auditory training.
- Creation of special sound effects.
- Simulating attenuation characteristics of structural partitions.
- Normalizing system frequency response.
- Equalization of phonograph and magnetic tape recordings.
- Spectrum analysis. (1612/S2L)
- Frequency compensation of non-linear recording and analysis systems.
- Simulating frequency-dependent transfer characteristics.
- Selective attenuation of equipment noise components for subjective evaluations (jury listening tests).
- Band stopping and limiting.
- "Tape Scrubbing" selectively removing interference from recordings.

MODEL 123. A variable band pass filter set with separate $\frac{1}{3}$ -octave control. Frequency range from 22 to 44,000 Hz. Shown in Rack Mounting.

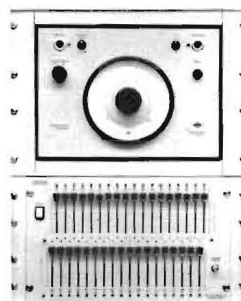
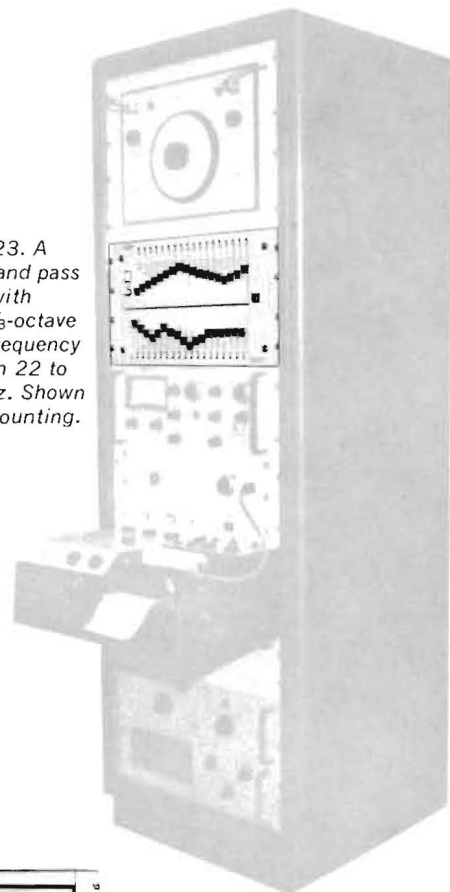

MODEL 1612/S2L. A variable band pass filter set with separate $\frac{1}{3}$ -octave control and contiguous $\frac{1}{3}$ -octave analysis capability. Frequency range from 22 to 44,000 Hz.



1/3-octave spectrum shapers

general description

The Model 123 is used to modify the overall frequency response of audio systems. The Model 1612/S2L is identical with the Model 123, but has the added capability of serial, $\frac{1}{3}$ -octave analysis.

Both instruments accomplish spectrum shaping by dividing the input into thirty-three $\frac{1}{3}$ -octave bands (thirty-six when used with the Model 1620 Extension Filter Set). The level in each band is individually attenuated and summed, then the composite signal is amplified.

The input signal drives up to thirty-six $\frac{1}{3}$ -octave passive filters. Thirty-three of these (with 25 Hz to 40 kHz center frequencies) are contained in the

Model 123 or Model 1612/S2L Shaper. Low frequency filters, with center frequencies of 12.5, 16 and 20 Hz, can be added by plugging in the Model 1620 Extension Filter Set.

Thirty-six solid state amplifiers couple the filter outputs to the 36 linear-motion, logarithmic taper attenuators. The attenuators are mounted on the front panel of the Spectrum Shaper in two rows. The vertical position of the attenuator control knobs represents the spectrum shape. Each attenuator controls the contribution of a $\frac{1}{3}$ -octave band to the total pass band. The 36 attenuator outputs are summed and amplified to produce a low impedance output.

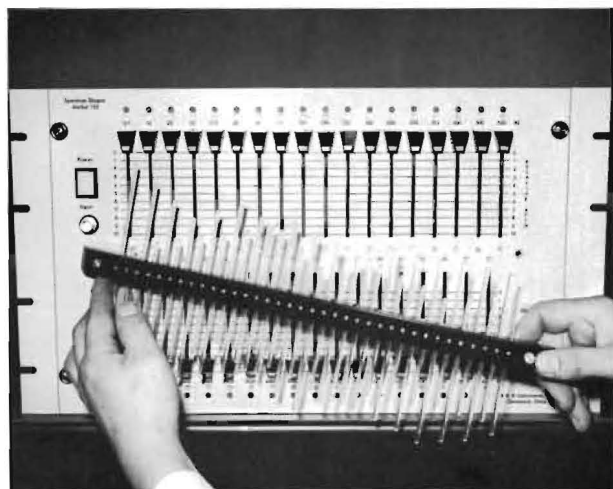

Figure 1. The memory bar recreates a previously-recorded spectrum.

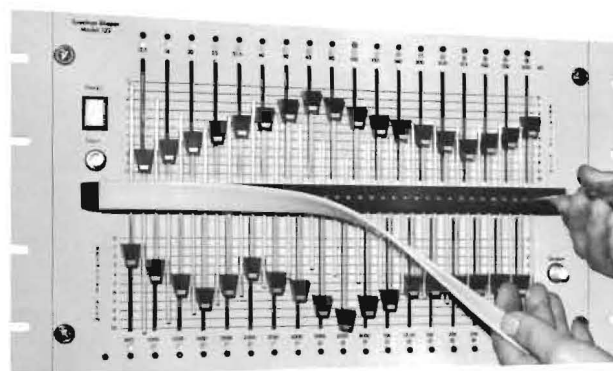

Figure 2. Set screws lock the memory bar's plastic rods in place.

Program Memory Bar

Certain applications require repeated use of the same spectrum. To accomplish this with minimum effort, a detachable memory bar is furnished with each Spectrum Shaper. (See Figure 1.)

Attenuator control positions are recorded by adjusting the memory bar's 36 movable plastic rods, which operate as stops. Set screws, located behind the

plastic trim strip, lock the rods in place. (See Figure 2.)

To recreate the spectrum, simply attach the memory bar to the front panel and run the attenuators against the bar's preset stops. The spectrum is reset in seconds. Positioning pins on the face panel and the memory bar prevent reversal during mounting. Extra memory bars are available.

Differences Between the Model 123 and Model 1612/S2L

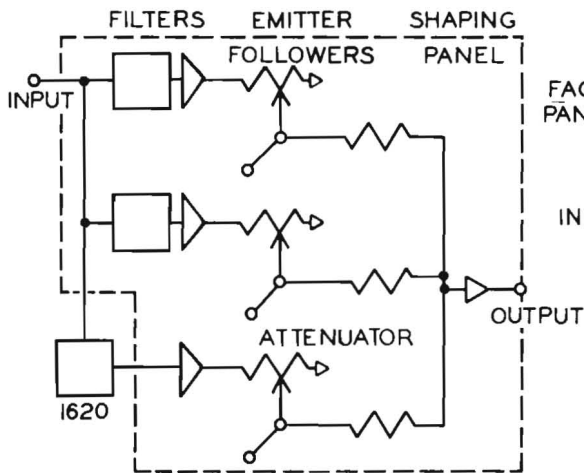

Block diagram of the Model 123.

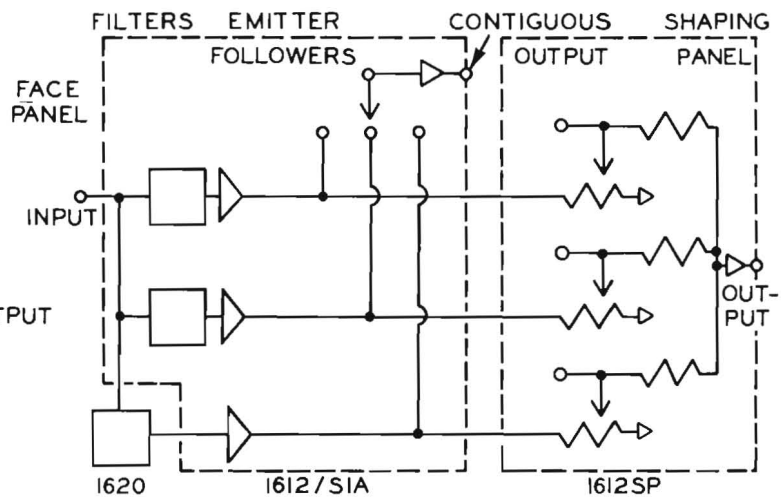

Block diagram of the Model 1612/S2L.

The Model 123 Spectrum Shaper will perform $\frac{1}{3}$ -octave spectrum shaping, but does not possess sequential analysis capability. All thirty-three filters are housed behind the face panel.

Components:

33 $\frac{1}{3}$ octave filters	36 attenuators
36 amplifiers	1 output amplifier

The Model 1612/S2L can be employed both as (1) a $\frac{1}{3}$ -octave spectrum shaper, and (2) a $\frac{1}{3}$ -octave sequential analyzer. The face panel, Model 1612SP, houses only the attenuator controls. Filters are contained in the Model 1612/S1A $\frac{1}{3}$ -octave filter set.

Components:

1612/S1A	
33 $\frac{1}{3}$ -octave filters	Sequential selector switch with remote control
36 amplifiers	
1612SP	
36 attenuators	1 output amplifier



Band-pass filter characteristics

Filters employed in the Spectrum Shapers are 3-section, L.C. passive elements. The band-pass characteristic of an individual filter is shown in Figure 3.

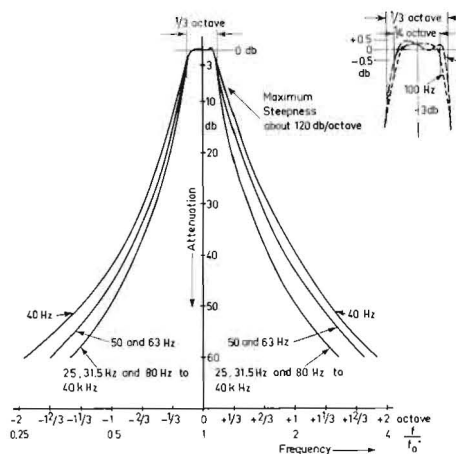

Figure 3. Band-pass characteristic of a single $\frac{1}{3}$ -octave passive filter.

Frequency response characteristics for the complete filter ensemble are shown in Figure 4.

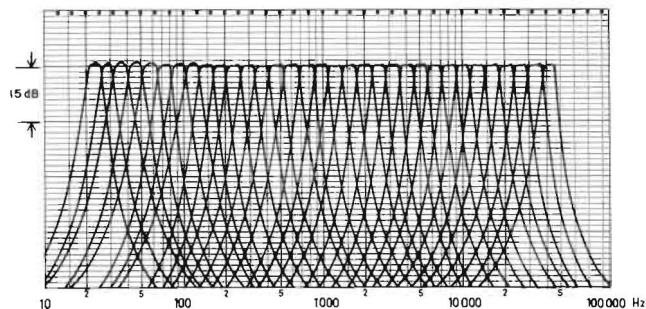

Figure 4. Complete set of filter characteristics of $\frac{1}{3}$ -octave filter ensemble.

Input Impedance

Input impedance of the standard Model 123 Spectrum Shaper varies between 300 and 2,000 ohms (see Figure 5). The input signal should be obtained from a source of 10 ohms or less. 100K Ω single ended input impedance (Option A) or 600 ohm transformer coupled input and output (Option B) is available.

The Model 123 is designed for a 1 volt RMS input, and will accommodate signals with crest factors up to 5.

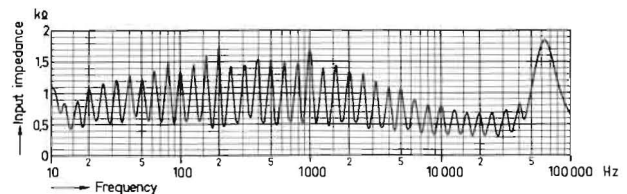

Figure 5. Input impedance as a function of frequency. (Standard Model 123).

The Model 1612/S2L will operate "directly," and features identical input characteristics to the Model 123. In addition, the 1612/S2L input can be switched through a coupling transformer, with 10-to-1 step-down ratio, to attain the input impedance characteristics shown in Figure 6. 100 K Ω input impedance can be provided (see Option A under specifications).

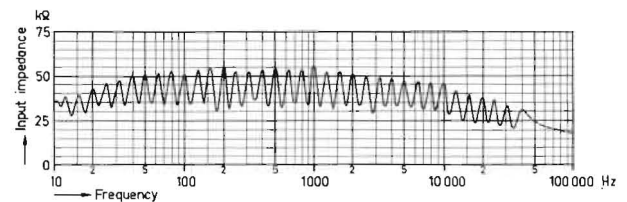

Figure 6. Input impedance, of the Model 1612/S2L in the transformer input mode.

Notch characteristics

The Spectrum Shaper is composed of parallel-driven separate one-third octave filters (meeting U.S.A.S.I. Class II filter specifications), each with its own adjustable attenuator.

The output of each attenuator is brought to a summing point, combined with the other channels and amplified.

The operator, by adjusting the attenuator of any $\frac{1}{3}$ -octave channel, can modify the frequency response of the Spectrum Shaper. Each attenuator has a range from 0 to -50 dB (or greater) and is electrically adjusted to give -20 dB at the mid-traverse position. The maximum notch which can be set is limited by the filter skirts of the adjacent filters. Passband characteristics for various attenuator settings are shown in Figures 7, 8 and 9.

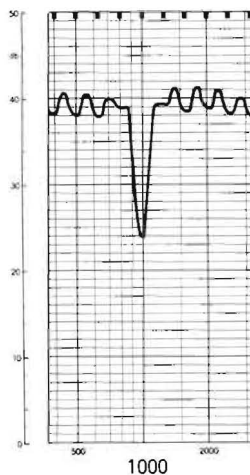

Figure 7. $\frac{1}{3}$ -octave notch obtained when one filter is set to maximum attenuation. This represents the intersection of the adjacent filter skirts.

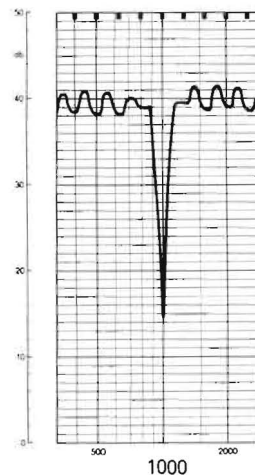

Figure 9. Notch obtained by adjusting attenuation for minimum signal in the notch. Under this condition, a portion of the notch signal balances spillover from adjacent filters.

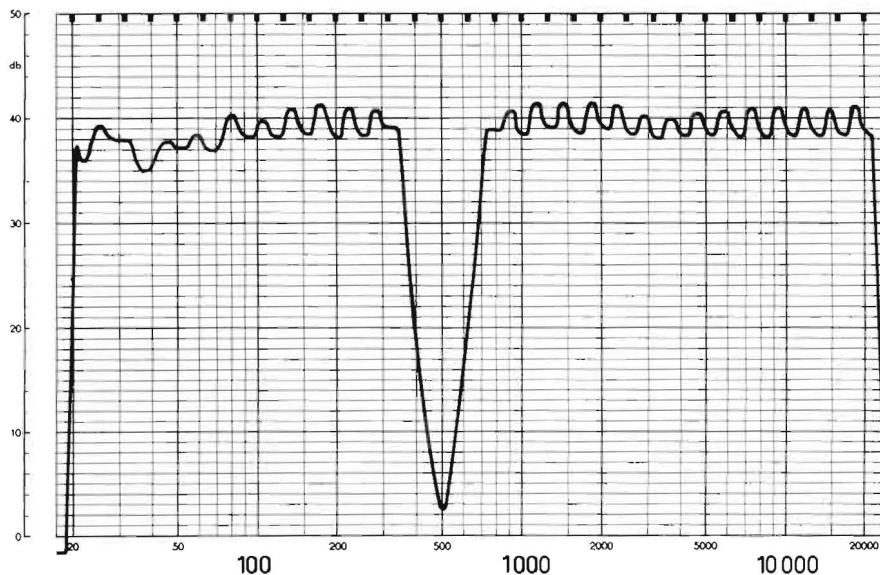

Figure 8. One-octave notch obtained by setting three adjacent channels to maximum attenuation. (Note that 36 dB attenuation is achieved.)



1/3-octave spectrum shapers

Roll off characteristics

The Model 1612/S2L and Model 123 Spectrum Shapers can be employed either as high or low pass filters, as shown in the following illustrations, Figures 10 and 11.

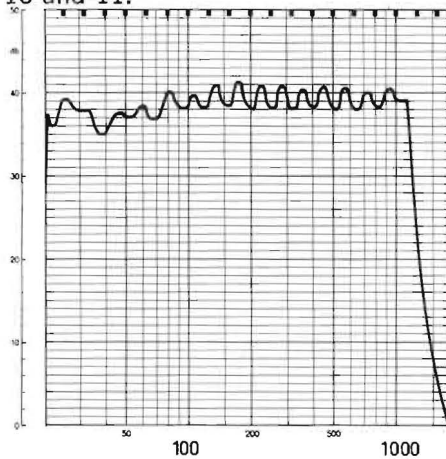

Figure 10. Pass band obtained when all attenuators above 1 kHz are set to maximum attenuation.

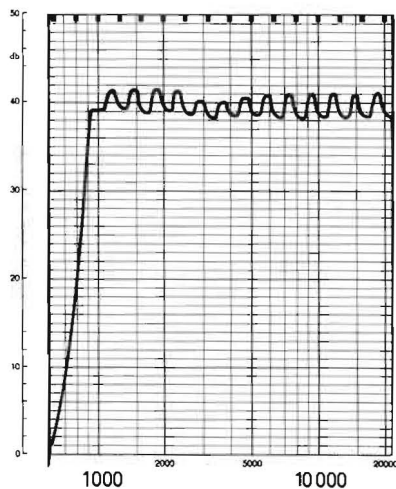

Figure 11. Pass band obtained when all attenuators below 1 kHz are set to maximum attenuation.

Band pass characteristics

Figures 12, 13 and 14 demonstrate the Spectrum Shapers' capability to function as a variable band pass filter. Attenuators for all unwanted frequencies are set to maximum attenuation.

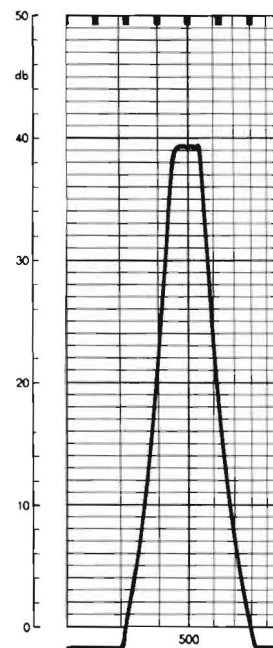

Figure 12. A single 1/3-octave band.

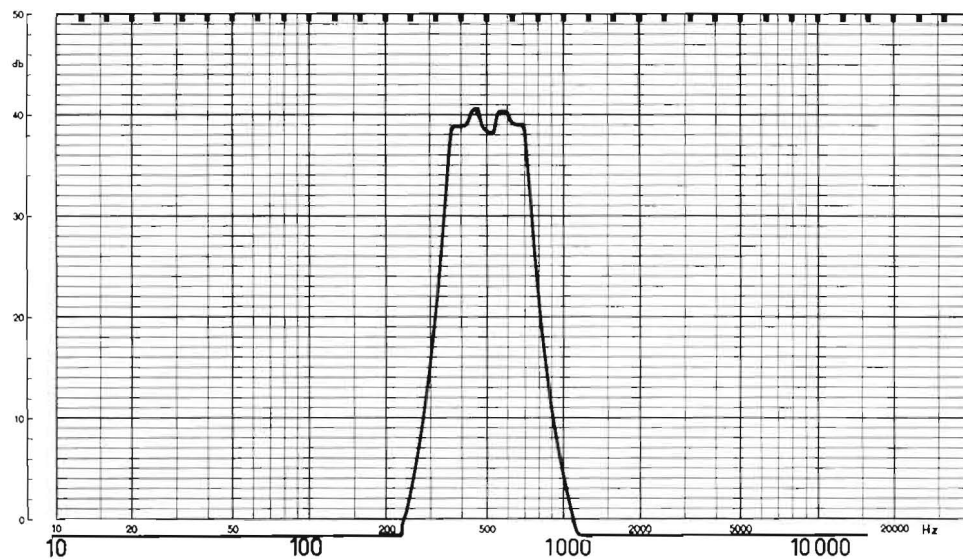

Figure 13. Three $\frac{1}{3}$ -octave pass bands combined to make a one-octave band pass filter.

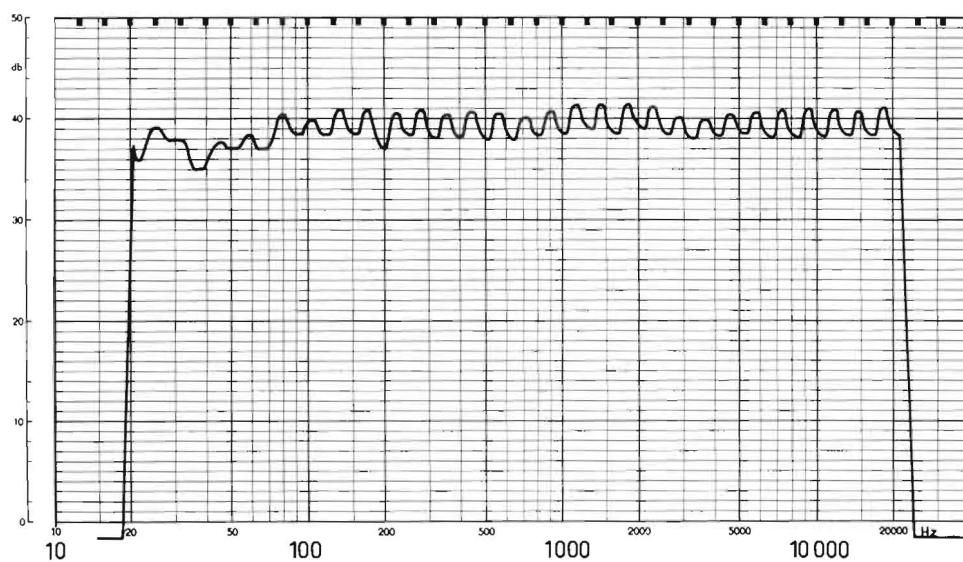

Figure 14. Pass band characteristics when all attenuators are set to minimum attenuation.



1/3-octave spectrum shapers

model
123
model
1612/S2L

specifications

Frequency Range:

22 to 45,000 Hz.

11 to 45,000 Hz when used with Model 1620 Extension Filter Set.

Band Pass Filters: 1/3-octave, 3-section type to U.S.A.S.I. Standards.

Selectivity of Individual Filters: From 40 to 52 dB at 1 octave from center frequency.

Source Resistance Necessary for Input Signal: 10 ohms or less.

Input Voltage: 1 volt RMS.

Selective Output: 1/3-octave from selector switch 1 volt amplitude.

Summed Output: direct—40 mV RMS.

Summed Output: (output amplifier): 1V RMS.

Signal to Noise Ratio: Better than 50 dB.

Scanning Method: Manual from front panel, or remote stepping from 28V supply. (Model 1612/S2L only.)

Stepper Load: 28V 180 mA.

Attenuator Controls: Total of 36: 33 used with internal filters; 3 used with 1620 Extension Filter Set.

Notch Attenuation, Maximum for One Filter: 25 dB or more.

Maximum Attenuation Slope: 40 dB/octave or better.

DIMENSIONS MODEL 1612/S2L

Filter Unit: 16" wide x 12" high x 14" deep; or 19" wide x 14" high x 14" deep when mounted in KS0003 rack-mount adapter.

Summing Panel: 19" wide x 10 1/2" high x 9" deep.

DIMENSIONS MODEL 123

Rack Mounted: 19" wide x 10 1/2" high x 9" deep.

Table Top: 17" wide x 10 1/2" high x 9" deep. (Rack mounting flanges unscrew from cabinet.)

ACCESSORIES

Model 1612/S2L

- 1—Model 123 PB-1 Program Bar
- 1—Test Cable
- 3—BNC Cable Connectors

Model 123

- 1—Model 123 PB-1 Program Bar
- 1—Test Cable
- 5—BNC Cable Connectors
- 1—JP-0019 Adaptor

OPTIONS

Option A (Models 1612/S2L and 123): Input amplifier to raise input impedance to 100KΩ.

Option B (Model 123 only): 600-ohm input and output transformers.

Option C (Model 123 only). By-Pass switch and choice of standard audio connectors.

Modifications of Model 1612

Existing Model 1612 Band Pass Filter Sets can be adapted to become the Model 1612/S2L. For further information, contact your nearest B & K representative or write B & K Instruments, Inc.

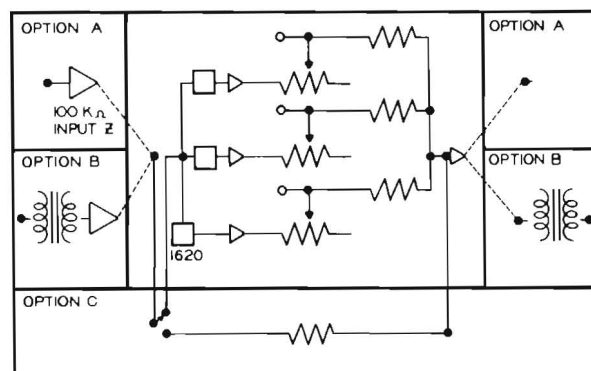

B & K INSTRUMENTS, INC.

Brüel & Kjær Precision Instruments

5111 West 164th Street • Cleveland, Ohio 44142
Telephone: (216) 267-4800 • TWX: (810) 421-8266

Form No. 8-213A



Crown

SX700



Leadership

Advanced DESIGN

- New modular transport
- Magnetic braking (patented)
- True straight line threading
- Lifetime engraved panel
- Precision micro-gap heads
- All silicon solid state
- Complete editing accessibility

Functional FLEXIBILITY

- Push button electrical control
- Automatic stop tape sensor
- Four, microphone or line, inputs
- Two stereo headphone outputs
- Bias metering and adjustment
- 3rd head monitor with A-B switch
- Sound with Sound recording

Exacting PERFORMANCE

- Hysteresis synchronous drive motor
- Precision machined for low wow
- Preamp response is uniform $\pm 1\text{db}$ 10 to 100,000 Hz
- Preamp distortion under 0.2%
- Preamp noise below -115dbm
- One year Warranty

PERFORMANCE

Speed	Response	S/N	F & W
7½ ips	$\pm 2\text{db}$ 30 — 25,000 HZ	-55db	0.09%
3¾ ips	$\pm 2\text{db}$ 30 — 15,000 Hz	-50db	0.18%

All CROWN recorders are professional quality equipment; therefore, this is the minimum long-term performance the user can expect on the SX724 when using Scotch 202 type tape.

*Every CROWN...
A Custom Product*

ACCESSORIES

SA30-30	60 watt stereo power amplifier
SLOT	Balanced 600 ohm output transformer
SMIT	50-250 ohm mic input transformer
HAP	Professional 10½" reel adapters
X	Carrying case



Crown



GENERAL PERFORMANCE CHARACTERISTICS AND SPECIFICATIONS

TAPE SPEEDS:	Two equalized speeds, 7½ and 3¾. Front panel speed change. Other speeds available on request.
TIMING:	99.8% or 1.8 seconds in 15 minutes, this can be micro-adjusted to ± 0.05% short term.
WOW & FLUTTER:	7½ ips - 0.09% 3¾ ips - 0.18% These figures are the guaranteed maximum values for record and playback.
TRANSPORT:	Four electrical push-button controls (forward, rewind, stop, operate) control the tape motion. Reel-size switch provides proper tension for either 10½ in. NAB or 7½ in. EIA reels. Micro-switch tape sensor stops operation in case of tape breakage or end-of-tape. Positive, solenoid-operated capstan pinch-roller. Stop and Operate functions may be remote controlled.
RECORD-PLAY:	SX724 specifications quoted on front page. SX722 two-track specifications are: 7½ ips ± 2 db 30 to 20,000 Hz 55 db S/N 3¾ ips ± 2 db 30 to 10,000 Hz 50 db S/N Using Scotch 202 type tape or equivalent These specifications represent minimum guaranteed performance. Included with each recorder is its own Record of Performance. Standard with NAB equalization, CCIR available.
SIGNAL-TO-NOISE RATIO:	Record and playback noise referenced to 400 cycles, 3% HD standard tape. Total harmonic distortion noise less than 1.5% for "O" record level @ 1KHz. Crosstalk rejection -55 db minimum.
STOP TIME:	One half inch at 3¾ ips. One inch at 7½ ips. Three seconds stop time from full rewind speed on 10½ inch reel. Patented CROWN brakes are non-mechanical, all electro-magnetic; thus never need adjusting.
WIND & REWIND:	1200 feet in 45 seconds. 2400 feet on 10½ inch reel in 58 seconds. The tape is not against heads during fast spooling.
HEAD ASSEMBLY:	Precision-built erase, record, and micro-gap playback heads are tripod mounted on a single rigid steel plate. Azimuth and tracking are independently adjustable, and are factory aligned and sealed.
CIRCUITRY:	Separate record and playback amplifiers provide complete isolation for monitoring while recording. All circuitry is on fiber-glass epoxy etched circuit boards with silicon transistors. Added feature is that all coupling capacitors are Mil. Spec. tantalum. Distortion through-out all audio circuits approaches the threshold of measurability.
INPUTS:	4 microphones or 4 lines (2-input mixer per channel). Microphone sensitivity is -66dbm (0.4MV) min. for "0" level. Line sensitivity is -25dbm (45MV) min. for "0" level. All input impedances are 100 K ohms or above.
OUTPUTS:	Two outputs per channel, one via pin jack and one via phone jack, are 600 ohm unbalanced with output up to 2.5 volts for "0" level. Maximum undistorted output is 14 volts. In addition, two outputs on the front panel accommodate two pairs of 600 ohm stereophones.
SPECIAL FEATURES:	Rugged transport has massive central casting which gives the rigidity to maintain perfect alignment between capstan and heads. Synchronous drive motor is coupled to 4 lb. balanced flywheel via flutter-filter belt drive. Capstan shaft is accurate to ± 12 millionths of an inch. Accessory AC outlet. Easily readable 5 inch professional VU meters with edge lighting. Bias frequency 100 Kc. Three-way record inter-lock.
MONITORING:	Each channel has front panel switch allowing monitoring from either: (A) SOURCE: Meter reads incoming signal to the record head. (B) TAPE: Meter reads the calibrated playback level, outputs are through output level controls.
POWER REQUIREMENTS:	140 watts, 117 volts AC, 60 cycles. 50 cps available.
SIZE:	15¾ in. high, 19 in. wide, 8 in. deep - less case. Dimensions with "X" case - 19½ in. high, 20¼ in. wide, 11 in. deep - including space for SA30-30, stereo amplifier.
WEIGHT:	Deck - 42 lbs, with "X" case 52 lbs, with "X" case and SA30-30 amplifier 60 lbs.

Crown
INTERNATIONAL
BOX 1000
ELKHART, INDIANA
PHONE: (219) 523-4919
117*8-68

MADE ONLY IN AMERICA

Skilled American craftsmen fabricate; assemble; and individually adjust each CROWN to provide you unequalled recording quality.

DEALER:



Crown

SX800

Advanced DESIGN

- New modular transport
- Magnetic braking (patented)
- True straight-line threading
- Lifetime anodized panel
- Precision micro-gap heads
- All silicon solid state
- Complete editing accessibility

Functional FLEXIBILITY

- Push-button electrical control
- Automatic stop tape sensor
- Four, microphone or line, inputs
- Two stereo headphone outputs
- Bias metering and adjustment
- 3rd head monitor with A-B switch
- Sound-with-Sound recording

Exacting PERFORMANCE

- Hysteresis synchronous drive motor
- Precision machined for low wow
- Preamp response is uniform $\pm 1\text{db}$ 10 to 100,000 Hz
- Preamp distortion under 0.2%
- Preamp noise below -115 dbm
- One year Warranty



The new PRO with COMPUTER LOGIC CONTROL

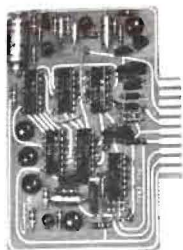

- no broken tapes ever again!
- computer-smooth instant response
- effortless, worry free tape handling

Another FIRST from Crown Leadership!

ACCESSORIES

SA30-30	60 watt stereo power amplifier
SLOT	Balanced 600 ohm output transformer
SMIT	50-250 ohm mic input transformer
HAP	Professional 10½" reel adapters
YM	Walnut-grain formica enclosure

PERFORMANCE

Speed	Response	S/N	F & W
7½ ips	$\pm 2\text{ db}$ 30 – 25,000 Hz	-55db	0.09%
3¼ ips	$\pm 2\text{ db}$ 30 – 15,000 Hz	-50db	0.18%

All CROWN recorders are professional quality equipment; therefore, this is the minimum long-term performance the user can expect on the SX824 when using Scotch 202 type tape.



Crown



GENERAL PERFORMANCE CHARACTERISTICS AND SPECIFICATIONS

TAPE SPEEDS:	Two equalized speeds, 7-1/2 and 3-3/4. Front Panel speed change. Other speeds available.
TIMING:	99.8% or 1.8 seconds in 15 minutes, this can be micro-adjusted to $\pm 0.05\%$ short term.
WOW & FLUTTER:	7-1/2 ips - 0.09% 3-3/4 ips - 0.18% These figures are the guaranteed maximum values for record and playback.
TRANSPORT:	Four lighted push buttons (FORWARD, REWIND, STOP, and OPERATE) control and indicate operation. These functions may be remote controlled with RC-40. Reel-size switch provides proper tension for either 10-1/2 inch NAB or 7 inch EIA reels. Photocell automatic stop halts operation in case of tape breakage or end-of-tape. This can also be used to sense windows in the tape for special cueing functions.
RECORD-PLAY:	SX824 specifications quoted on front page. SX822 two-track specifications are: 7-1/2 ips + 2 db 30 to 20,000 Hz 55 db S/N 3-3/4 ips \mp 2 db 30 to 10,000 Hz 50 db S/N > Using Scotch 202 type tape or equivalent These specifications represent minimum guaranteed performance. Included with each recorder is its own Record of Performance. Standard with NAB equalization.
SIGNAL-TO-NOISE RATIO:	Record and playback noise referenced to 400 cycles, 3% HD standard tape. Total harmonic distortion noise less than 1.5% for "O" record level @ 1KHz. Crosstalk rejection -55 db minimum.
STOP TIME:	One half inch at 3-3/4 ips. One inch at 7-1/2 ips. Three seconds stop time from full rewind speed on 10-1/2 inch reel. Patented CROWN brakes are non-mechanical, all electro-magnetic; thus never need adjusting.
WIND & REWIND:	1200 feet in 38 seconds. 2400 feet on 10-1/2 inch reel in 58 seconds. The tape is not against heads during fast spooling.
HEAD ASSEMBLY:	Precision-built erase, record, and micro-gap playback heads are tripod mounted on a single rigid steel plate. Azimuth and tracking are independently adjustable, and are factory aligned and sealed.
CIRCUITRY:	Separate record and playback amplifiers provide complete isolation for monitoring while recording. All circuitry is on fiber-glass epoxy etched circuit boards with silicon transistors. Added feature is that all coupling capacitors are Mil. Spec. tantalum. Distortion through-out all audio circuits approaches the threshold of measureability.
INPUTS:	4 microphones or 4 lines (2-input mixer per channel). Microphone sensitivity is - 66dbm (0.4 MV) min. for "O" level. Line sensitivity is - 25dbm (45MV) min. for "O" level. All input impedances are 100 K ohms or above.
OUTPUTS:	Two outputs per channel, one via pin jack and one via phone jack, are 600 ohm unbalanced with output up to 2.5 volts for "O" level. Maximum undistorted output is 14 volts. In addition, two outputs on the front panel accommodate two pairs of 600 ohm stereophones.
SPECIAL FEATURES:	Rugged transport has massive central casting which gives the rigidity to maintain perfect alignment between capstan and heads. Synchronous drive motor is coupled to 4 lb. balanced flywheel via flutter-filter belt drive. Capstan shaft is accurate to ± 12 millionths of an inch. Accessory AC outlet. Easily readable 5-inch professional VU meters with edge lighting. Bias frequency 100 Kc. Three-way record inter-lock.
MONITORING:	Each channel has front panel switch allowing monitoring from either: (A) SOURCE: Meter reads incoming signal to the record head. (B) TAPE: Meter reads the calibrated playback level, outputs are through output level controls.
POWER REQUIREMENTS:	140 watts, 117 volts AC, 60 cycles. 50 cps available.
SIZE:	15-3/4" high, 19" wide, 8" deep - less enclosure. Dimensions with "YM" enclosure 22-1/4" high, 25-1/8" wide, 11-1/4" deep - including space for SA30-30, stereo amplifier.
WEIGHT:	Deck - 48 lbs, with "YM" enclosure 64 lbs, with "YM" enclosure and SA30-30 amplifier 72 lbs.

Crown

INTERNATIONAL
BOX 1000
ELKHART, INDIANA
PHONE: (219) 523-4919

124*6-68

MADE ONLY IN AMERICA

Skilled American craftsmen fabricate, assemble, and individually adjust each CROWN to provide you unequalled quality.

DEALER



Crown

DC 300



DUAL-CHANNEL BASIC AMPLIFIER



Leadership

LAB STANDARD

HIGH FIDELITY:

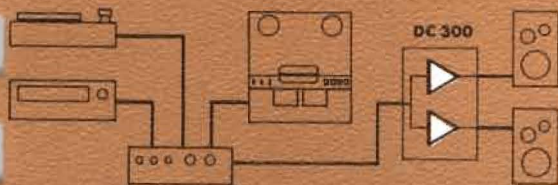

SOUND REINFORCEMENT:

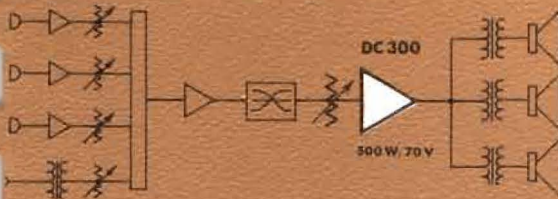

STUDIO MONITOR:

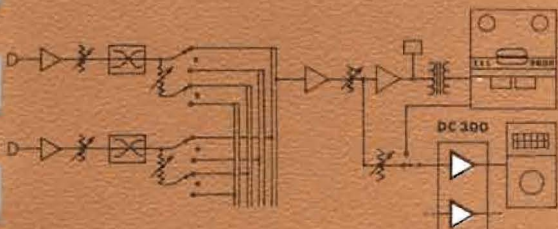

ACOUSTICS LABORATORY:

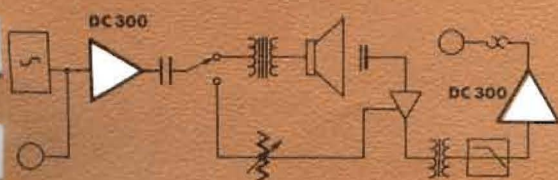

The goals achieved in the DC-300 are those of a Laboratory Standard—heretofore unattainable in a power amplifier of modest price. New perfection is realized in the areas of distortion, noise, stability, self-protection, power output and economy. It is possible to obtain a monaural 70.7 v balanced output without a transformer.

Unlike ordinary AC-coupled amplifiers, the DC-300 exhibits a near perfect "transfer function"—completely linear gain-bandwidth, excellent phase response and instantaneous overload recovery (even on non-symmetrical waveforms). The behavior of any load is not influenced by the negligible internal impedance.

A total of 38 discrete transistors, 2 differential (dual) transistors, 28 diodes and 6 zener diodes are utilized in the unique direct-coupled circuitry (patent pending). Self-protection is threefold—VI limiting, thermal breakers, and overall fusing of the 60-amp-rated output devices. A massive 1 KW power supply drives the amp, and features quad-regulation of input stages.

When reproducing complex waveforms as in music, the total clarity and astonishing ease of the DC-300 is immediately apparent—even with "medium" transducers. Steady-state power output is prodigious—independent of waveform, with solid, linear response to DC. This amplifier most nearly approaches the Ideal—a "Straight Wire with Gain."

A few Reports from the Field:

C. B. of Pennsylvania (Dealer and Recording Studio) IT'S FABULOUS!

M. R. of California (Customer) QUITE POSSIBLY THE BEST AMPLIFIER TO DATE.

R. G. of California (Audio Engineer) THIS AMPLIFIER INCORPORATES THE CIRCUITRY OF THE FUTURE. THIS IS THE PRODUCT WE'VE BEEN LOOKING FOR.

R. F. of Minnesota (Engineer and Rep) INCOMPARABLE! MEETS OR EXCEEDS ALL SPECS—THE FINEST AMP I HAVE EVER MEASURED!



COMPLETE SPECIFICATIONS:

- Frequency Response ± 0.1 db Zero -20KHz at 1 watt into 8 ohms, ± 0.6 db Zero -100 KHz.
- Phase Response Less than 5° , 0-10 KHz.
- Power Response ± 1 db Zero -20KHz at 150 watts RMS into 8 ohms.
- Power at Clip Point Typically 190 watts RMS into 8 ohms, 340 watts RMS into 4 ohms per channel (see graphs).
- Total Output (IHF) Typically 420 watts RMS into 8 ohms, 800 watts RMS into 4 ohms (see graphs).
- I.M. Distortion (60-7KHz 4:1) Less than 0.1% from 0.01 watt to 150 watts RMS into 8 ohms, typically below 0.05%. (max. 0.05%, see graphs.)
- Damping Factor Greater than 200 (Zero to 1KHz into 8 ohms at 150 watts RMS)
- Hum and Noise (20-20KHz) 100db below 150 watts RMS output (unweighted, typical 110db).
- Slewing Rate 8 volts per micro-second. S-R is the maximum value of the first derivative of the output signal.
- Load Impedance 4 ohms or greater. Stable with all speaker loads. Stable with all capacitors less than 1mfd, and all capacitors if isolated by 1 ohm. For V-I limiting values see Section 3.
- Input Sensitivity 1.75 $\pm 2\%$ for 150 watts into 8 ohms (26db gain, ± 0.1 db)
- Input Impedance Nominal 100K ohms (10K ohms at full gain).
- Turn-On Instantaneous, with no thumps or program delay.
- Load Protection Short, mismatch, and open-circuit proof. V-I limiting is instantaneous with no annoying thumps, cutout, etc.
- Overall Protection All main supplies and line voltage are independently fused. Thermal switches in AC line protect against over-heating caused by insufficient ventilation. Four spare fuses for main supplies are stored on the inside of front-panel fuse access door. Controlled-slewing-rate voltage amplifiers protect overall amplifier against RF burnouts. Input overload protection is furnished by internal resistance at inputs of amp.
- Power Supply 1KW transformer with heavily-heat-sinked high-current diodes and massive computer-grade filter capacitors storing over 48 joules of energy. Total of four regulated supplies (2 per channel) for complete isolation and stability.
- Power Requirements Requires 50 to 400 Hz AC with adjustable taps for 117, 125, 234, 250V $\pm 10\%$ operation. Draws 40 watts or less on idle, 500 watts at 300 watts output into 8 ohms per channel.
- Heat Sinking Massive black-anodized heat sinks are thermally joined with chassis, thereby utilizing the entire amplifier as a heat sink.
- Chassis All-aluminum construction for maximum heat conduction and minimum weight. Heavy 3/16 in. aluminum front panel is reinforced by a rugged aluminum extrusion along its lower front.
- Controls Heavy-duty independent input level controls are on front panel. Power switch, with adjacent pilot light is on front panel. Non-interacting DC balance controls are mounted behind screwdriver access holes which are behind front-panel access door. Slide switches mounted on sides allow two modes of V-I limiting, one being for high-hysteresis loads.
- Connectors Input - 1/4 in. phone jack.
Output - Color coded binding posts and 1/4 in. phone jack.
AC Line - Three-wire (grounded) male connector on 5 ft. min. cable.
- Dimensions 19 in. standard rack mount (W.E. hole spacing), 7 in. height, 9 1/2 in. deep (from mounting surface).
- Weight 40 pounds net weight.
- Finish Bright-anodized brushed-aluminum front-panel with black-anodized front extrusion, access door, and chassis.

WARRANTY: 3-YEARS, PARTS and LABOR
PRICE: \$685, P-A Adapter \$75

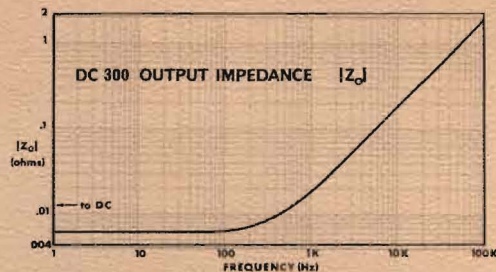
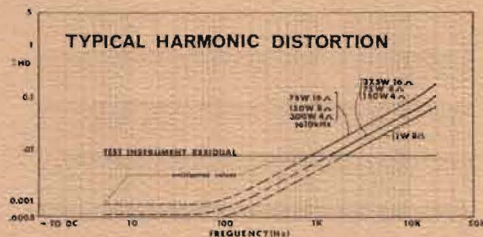
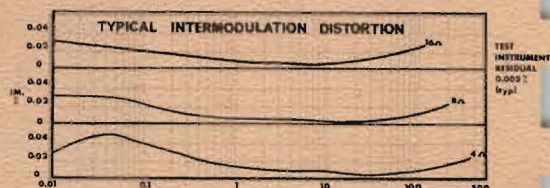
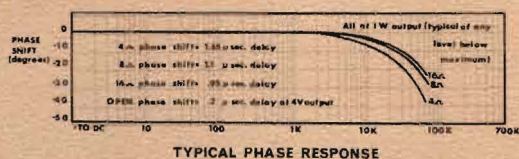
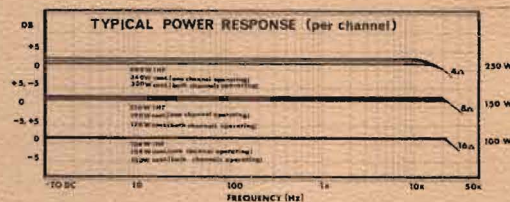
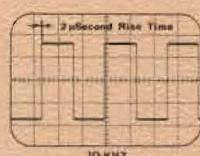
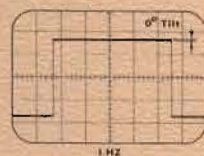

MADE ONLY IN AMERICA

Skilled American craftsmen fabricate, assemble, and individually adjust each CROWN to provide you unequalled quality.

BOX 1000
ELKHART, INDIANA
PHONE: (219) 523-4919
126 *9-68

DEALER



Crown

SA 30-30



SOLID STATE

Leadership

An IDEAL Amplifier

POWER - PERFORMANCE - PACKAGE - PRICE

Home.

- Superb damping factor (over 200)
- Power bandwidth 10 - 100,000 Hz
- Superb square wave and overload response
- Optional accessory cover available
- Biamplifier 'Tweeter-woofer' Doubles power (Mono)

Industry..

- Glass epoxy circuit boards
- Military - Grade Workmanship and parts
- Complete stability under any load
- Fully fuse - Protected circuitry

Broadcasting...

- Standard 19" rack Design - only 1 3/4" thin
- Optional balanced input (10 K \sim bridging, 600 \sim)
- Input level control for each channel
- Available in monaural as model SA - 30

Recording Studio...

- Easily portable - only 7 1/2 pounds light
- Highly efficient - 10 w. idling power
- Match any load impedance from 4 - 16 ohms
- Dual input and output jacks for flexibility

Sound Reinforcement.....

- Test units operating over 10,000 hrs. at 60 watt output with no measurable deterioration in performance or parts
- Very low harmonic and intermodulation distortion at all power levels below maximum output
- Direct 25 V line output with accessory transformer
- 1 year parts warranty (unconditional)

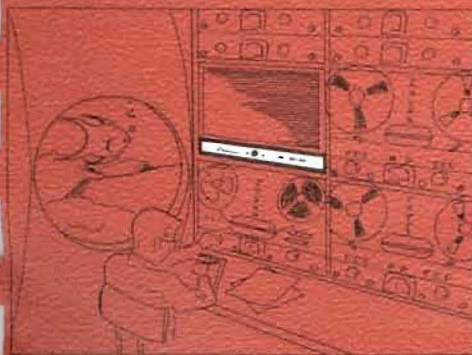
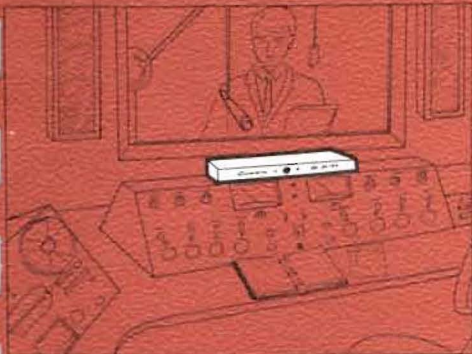
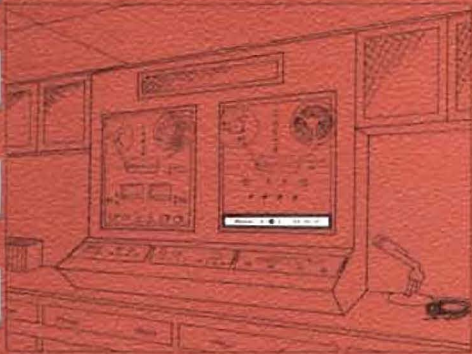

- 👑 Power bandwidth = 0 - 100 KHz
- 👑 Input level = 0.6 volt min.
(for full output) = -2 dbm bridging
- 👑 Input impedance - 12 K Ω min.
- 👑 Voltage gain - 26 db min.
- 👑 Power density - 360 w/cu. ft.
- 👑 Output load = 4 to 16 Ω (transformer loads must be isolated with series capacity)
- 👑 Rise time = Less than 2 msec (1 watt, 10,000 Hz square wave)
- 👑 Controls = Power on-off, pilot light, input level control (dual)
- 👑 Power consumption - 117 vac at 170 watts (10 watts idle)
- 👑 Dimensions - 19 (std. rack) width, x 1 3/4 high, x 7 1/2 deep (8 5/8 overall).
- 👑 Response = ± 0.1 db 20 Hz to 20,000 Hz
± 1.0 db 5 Hz to 100,000 Hz
- 👑 Hum & noise = 90 db below 30 watts
- 👑 Damping factor = in excess of 200 (50 Hz)
- 👑 Weight - 7 1/2 pounds (with case, 9 pounds)



TYPICAL CHARACTERISTICS..

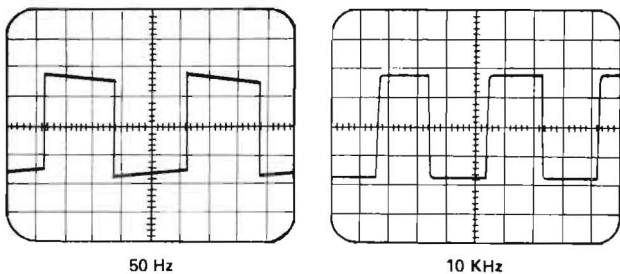

Square Wave Response (1 watt)

Music is composed of many transients; square wave response testing is indicative of rise time and recovery performance of an amplifier to transients.

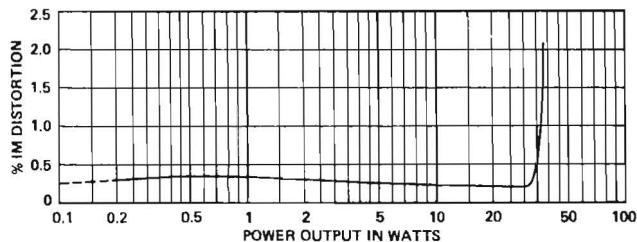

Intermodulation Distortion (1 chan, 8 Ω) 60 Hz and 7000 Hz (mixed 4:1)
Low intermodulation distortion at all power output levels below clipping ensures complete tonal clarity, and separation of complex sounds.

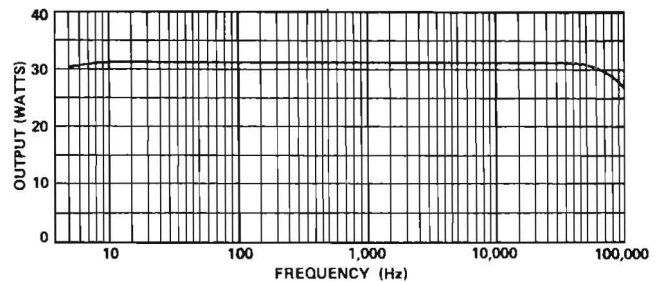

Frequency Response (32 watts @ 8 Ω)

Relative to transient response, wide-band response at maximum power output ensures undistorted sforzandos of the most demanding musical passages.

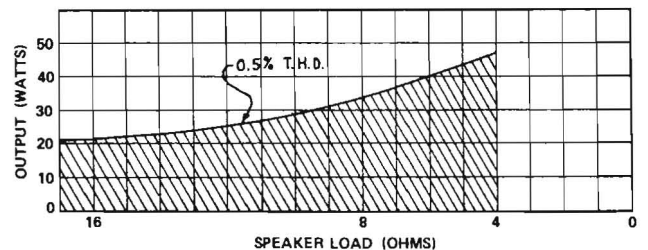

The impedance of all loudspeakers varies with frequency. The SA 30 - 30 has extra reserve power for any load with lowest distortion.

Warranty: All parts guaranteed 1 year (including transistors & diodes), 90 days labor.

Price: Only \$199.00, with black cover \$215.00 Monaural (\$145.00 and \$161.00)

Crown
INTERNATIONAL
BOX 1000
ELKHART, INDIANA
PHONE: (219) 523-4919

MADE ONLY IN AMERICA

Skilled American craftsmen fabricate, assemble, and individually adjust each CROWN to provide you unequalled quality.

DEALER:

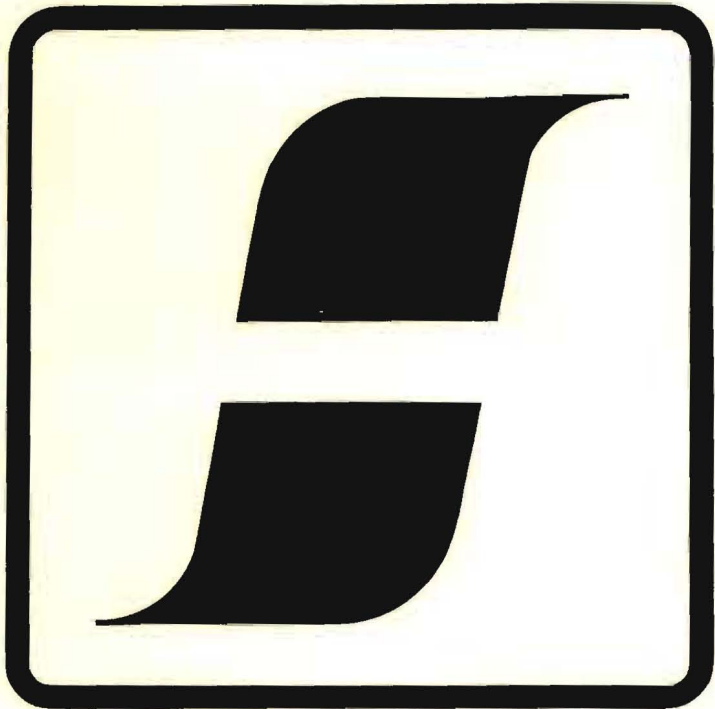

GAUSS SERIES 1200

ULTRA HIGH SPEED

MAGNETIC TAPE DUPLICATION SYSTEMS

with Focused Gap* Recording Process

GAUSS ELECTROPHYSICS INC.

1653 12th Street an MCA INC. company
Santa Monica, California 90404 U.S.A.

Phone: (213) 451-9876

Cable: Gauss Santa Monica

*TM — GAUSS ELECTROPHYSICS, INC.

SERIES 1200 ULTRA HIGH SPEED TAPE DUPLICATING EQUIPMENT EMPLOYS GAUSS EX-
CLUSIVE FOCUSED GAP recording process and provides duplication ratios of 32 to 1, or 16 to 1 with
unsurpassed fidelity.

All Series 1210 and 1220 equipment is compatible with early Series G12, and all machines are wired
for a maximum of eight channels of reproduce or record to enable quick conversion to different tape
formats. All equipment is available for operation on 100/125 and 200/240 volts, 50 or 60 Hz. When
ordering, specify mains voltage and frequency.

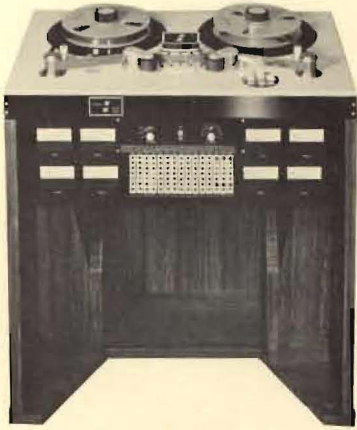

**Model 1210 Master
Reproducer in Console**



**Model 1260 Endless Tape
Loop Bin in Console**

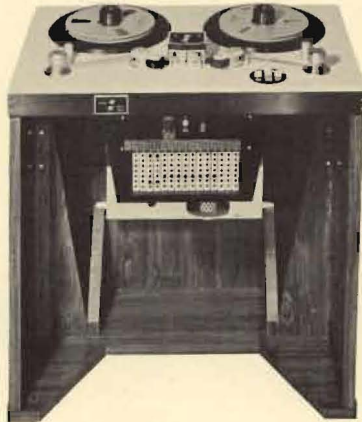

**Model 1220 Slave
Recorder in Console**

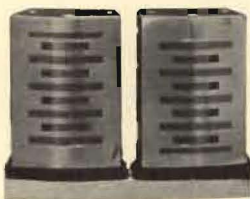

**All Metal Head
Assembly, 8-T, 1 in.**



**C2 Test Head with
VU Meter and Pre-Amplifier**

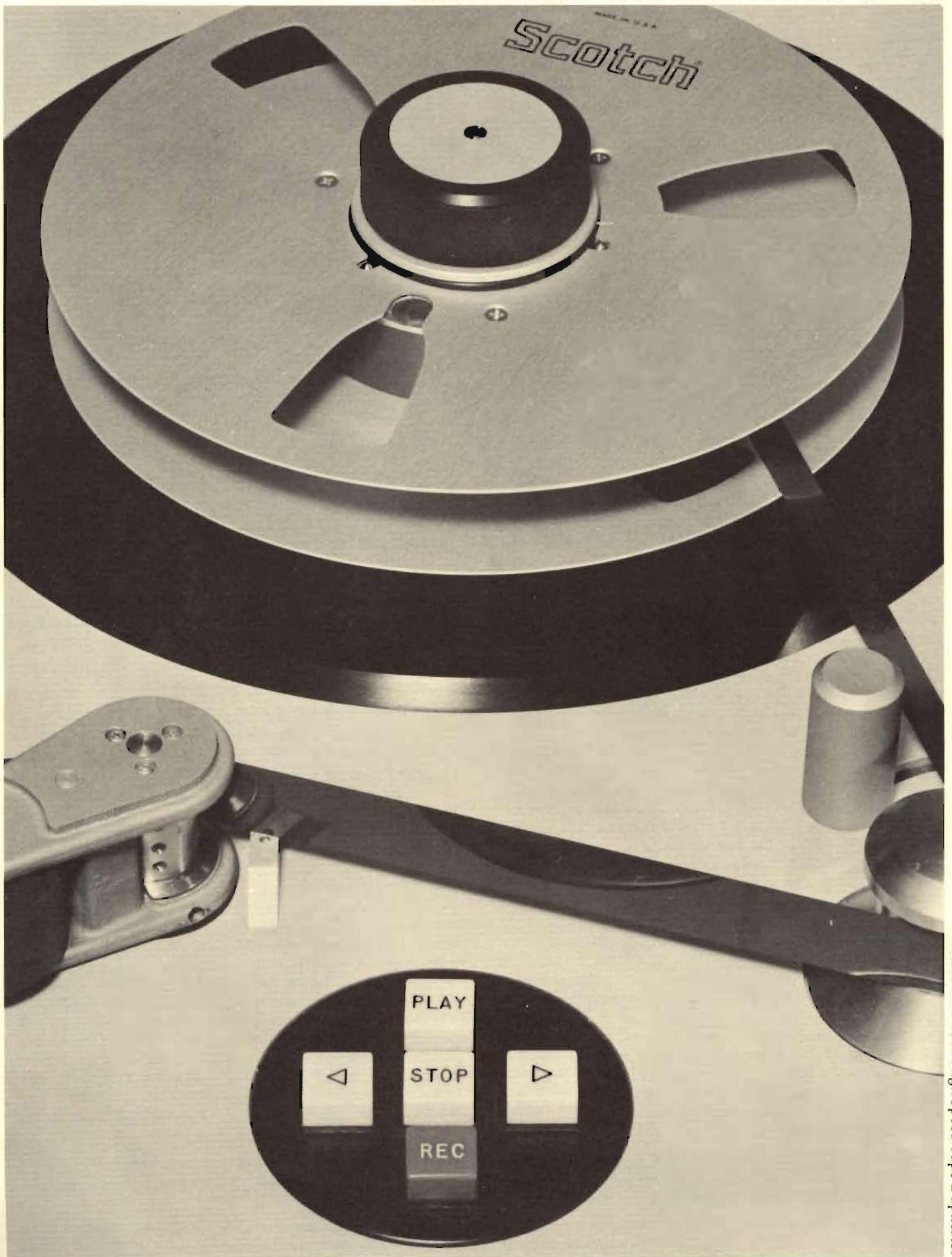

Series 1200 Ultra High Speed Tape Duplicator



Model 1210 Master Reproducer (Left) with Model 1220 Slave Recorder, in console cabinets.

ADVANCED FEATURES

- Extended Range Focused Gap* Recording Process
- Duplication At 3 Speeds To 240 IPS
- Rapid Threading Closed-Loop Tape Drive
- Servo Controlled Tape Tensions
- Hi-Reliability Solid-State Electronics
- Modular Plug-In Heads And Electronics
- Quickly Convertible Between Tape Formats

The Gauss Series 1200 magnetic tape duplicating system produces volumes of recorded sound information at high speed in much the same way a printing press reproduces the written word. As an example, the master tape playback unit operating at 32 times the original recording speed can drive up to 20 slave recorders producing over 4000 copies of a thirty-minute cartridge program each hour.

This is the first duplication system ever designed specifically for high volume industrial applications. Maximum output per dollar invested is guaranteed by its high efficiency and reliability.

The Series 1200 is completely modular and can be provided in configurations to fit any duplication requirement. Each 1210 Master Reproducer will drive from one to twenty 1220 Slave Recorders, and the slaves are completely independent so a system may be gradually expanded with increased demand.

The design of the Series 1200 is tailored to the specific needs of the duplicator user and numerous exclusive features aimed at maximizing production, performance and reliability are incorporated in the system—

- The unique Gauss Focused Gap Head provides up to 6 db improvement in high frequency tape saturation and reduces intermodulation distortion up to 90%.
- Full-time electronic servo control of tape tensions at both supply and take-up reels assures gentle tape handling without tape damage.

- The dual-capstan, closed-loop, direct drive provides nearly perfect tape speed accuracy and eliminates the speed stability problems found with conventional indirect "rubber-tire" drives.
- Slanted-pole DC torque motors are used to eliminate cogging, vibration and to minimize transport heating.
- All electronics are solid-state plug-in modules.
- Peak-reading VU meters are standard for the first time providing truly accurate on-line monitoring of signal levels.
- All standard tape formats can be accommodated, and conversion from one format to another can be made in less than 30 minutes.

FOCUSED GAP HEAD

The Gauss Focused Gap recording process utilized in the 1220 Slave Recorders represents a breakthrough in recording technology. This "beamed bias" process is based upon an entirely new design which functions as an almost perfect anhysteretic magnetic recording device.

The Focused Gap Head is capable of sharply focusing the radio frequency bias field achieving flux gradient almost an order of magnitude greater than any conventional record head, and the resulting increase in field intensity assures that all particles in the tape are fully biased. The Focused Gap process provides the exceptionally high audio quality found in copies made on Series 1200 Duplicators and improved performance in the following specific areas is guaranteed—

- Biased tape noise is no greater than 2 db over bulk erased tape noise.
- High frequency saturation is improved up to 6 db.
- 10 MHz (nominal) Bias completely eliminates "bias birdies" over entire audio spectrum.
- Bias self-erasure is practically eliminated reducing high frequency intermodulation distortion to approximately 1/10th that of conventional recording.

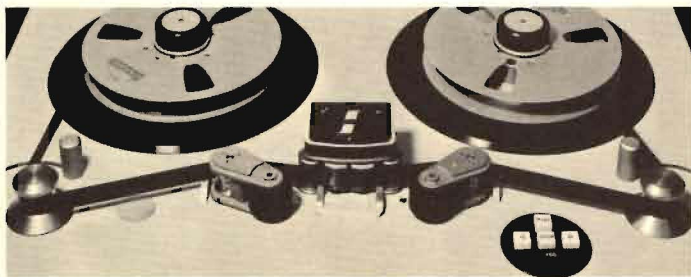

Series 1200 tape transport with closed-loop drive.

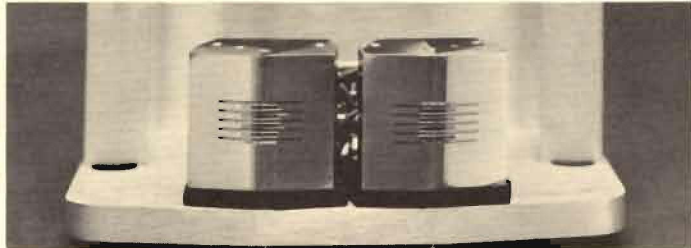

Model 1220 Focused Gap record head assembly, 8-T, ¼ in.

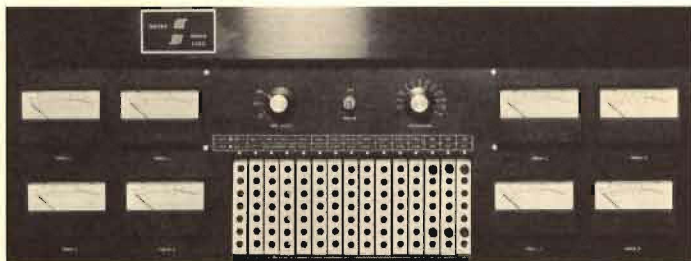

Model 1210 VU meter panel with ganged master level control.

□ Penetration of the Focused Gap bias field into the tape oxide reduces long wave-length dropouts by up to 50%.

In addition, the gap scatter in all Gauss heads is held within 20 micro-inches assuring the perfect track-to-track timing so necessary to maintaining stereo realism and mono / stereo compatibility. Gauss heads are of all-metal construction for long life.

TRANSPORT

The Series 1200 Transport provides a massive, extremely rigid tape guiding surface assuring mechanical stability without flexing. A closed-loop, dual-capstan drive is used to eliminate scrape flutter and provide positive control of tape tensions in the head area. Each capstan is driven directly by its own synchronous motor to assure accuracy of tape speed without adjustment.

The tape tension for each reel is independently controlled by a separate electronic servo system, and therefore the tape pack is always smooth and uniform. DC reel motors with slant-oriented rotors provide constant tension without cogging and vibration, and they operate at a low power level minimizing transport heating. The tape threading path is a simple direct line to speed reloading and minimize downtime.

The 1200 Transport is designed to operate with any standard tape format, and changes from one format to another can be accomplished by plug-in components in less than 30 minutes. The reel hold-down knobs accommodate 7 inch plastic reels as well as the larger 10½ or 14 inch NAB reel hubs. The 1200 Master Transport handles ¼, ½ inch and 1 inch wide tape, and the Slave Transport handles both ¼ inch and the ⅞ inch cassette tapes (150 mil). The 1200 head assemblies are plug-in and can be changed in less than 5 minutes.

ELECTRONICS

The Gauss Series 1200 electronics functions include record, bias, reproduce, monitor and control logic. Each master and



Model 1210 tilt-up console cabinet.

each slave is provided with its own completely independent electronics complement, and therefore a Series 1200 system is easily converted or expanded without modification or realignment. Independent electronics minimize repair downtime, too, since a failure in one slave will not affect the production of other slaves. System set-up and adjustment is simple.

The 1200 employs modern, solid-state circuitry throughout. All logic functions are performed electronically, and relays are used only to inter-face with power-demanding solenoids and motors. Highly reliable, modular, printed circuit construction is used throughout.

A meter monitoring system is available on the master reproducer for on-line verification of actual line levels. A VU meter, indicating peak record level in VU and DB, is provided for each duplication channel. Previous to introduction of the Series 1200, on-line monitoring did not provide significant accuracy because of the difficulty of converting audio levels (originally recorded at slow speeds such as at 7½ ips) to a meaningful meter reading during high speed (240 ips) duplication. The 1200's peak level metering solves this problem.

Also provided exclusively in the Gauss Series 1210 is a ganged master gain control which permits simultaneous adjustment of all record channels with a single knob. This feature eliminates time consuming readjustment of levels on individual channels.

RELIABILITY AND EASE OF MAINTENANCE

The Series 1200 is designed to provide the user with maximum reliability and ease of servicing.

The system is modular in design, and major components can be replaced without realignment. The transport tilts to a vertical position in its console providing access to mechanical and electronic components. All circuitry is solid-state, and plug-in printed circuit board construction is used.

The Gauss head assemblies are of all-metal construction, and have a guaranteed gap depth of at least 10 mils assuring a head

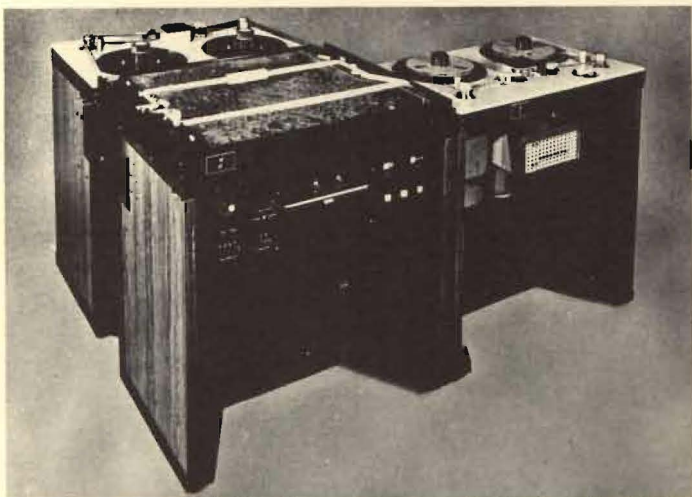

Series 1200 basic system (Master Reproducer, Loop-Bin and Slave Recorder).

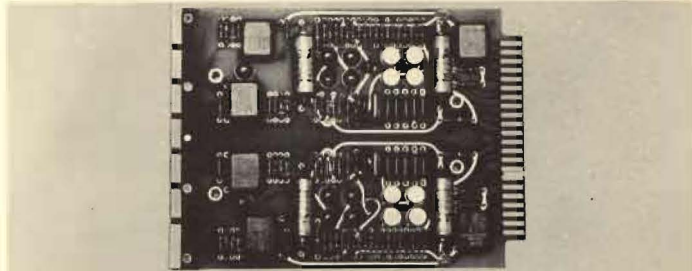

A typical Series 1200 plug-in circuit card.

life of thousands of hours.

As a final assurance of quality, Gauss warrants the entire 1200 system against defects in materials and workmanship for one year, and on heads the warranty extends for two years on a pro-rata basis.

SPECIAL APPLICATIONS

The Series 1200 is versatile and can be used in many applications where high quality and quantity production of direct recorded magnetic tapes is required.

It should be remembered that copies made using its wide-band high speed capability will be superior in quality to any copy made on "real time," one-to-one recorders. Recording studios, therefore, will find the 1200 a cost-reducing asset in the production of virtually identical copies of precious master tapes for distribution to licensees.

Network installations linked by microwave or coaxial cable may transmit complete programs in $\frac{1}{32}$ the real playing time (example: a 2-hour program in just $3\frac{3}{4}$ minutes), with full fidelity maintained.

The 1200 slave unit can be used as a general purpose instrumentation recorder with speeds up to 240 ips, as well as for duplication of low and medium band (1 MHz at 60 ips) instrumentation tapes.

These and other customized versions can be made available on request.

ACCESSORIES

Convenience accessories are available including a console cabinet, sweep frequency tape, and test head with pre-amplifier to aid in system alignment.

SPECIFICATIONS

(Note: All applicable specifications pertain to the real time playback speed of duplicated copies.)

TYPE OF ELECTRONICS

All solid-state circuitry with plug-in solid-state printed circuit cards.

FREQUENCY RESPONSE

Maximum deviation on duplicated copies from master tapes recorded at $7\frac{1}{2}$ ips (NAB equalization).

Playback Speed	Frequency Response
$3\frac{3}{4}$ ips	± 3 db, 30 to 12 KHz
1 $\frac{7}{8}$ ips	± 3 db, 30 to 10 KHz

Other speed/equalization available on request.

SIGNAL TO NOISE RATIO (ASA Curve A)

Biased tape noise on copies: Does not exceed bulk erased tape noise by more than 2 db.

CROSSTALK REJECTION (Referenced to $\frac{1}{4}$ inch RIAA tape format)

Frequency	8-Track	4-Track	2-Track
Below 250 Hz	30 db	40 db	40 db
Above 250 Hz	50 db	55 db	55 db

TOTAL HARMONIC DISTORTION (Referenced to industry standard level - 1% total harmonic distortion at 500 Hz)

- Does not add more than 0.7% THD on duplicated copy.
- Electronics only - less than $\frac{1}{4}$ % THD.
- At 15 db above standard operating level total system distortion due to electronics is less than 1% THD.

RECORDING PROCESS - Direct Record Focused Gap* (Beamed RF Bias).

OVERLOAD MARGIN

At least 15 db above tape saturation.

RECORD BIAS SYSTEM

- Frequency: 10 MHz nominal, crystal controlled; frequency stability $\pm .002\%$.
- Independent bias system for each slave recorder.

EQUALIZATION

- Master reproducer accepts $7\frac{1}{2}$ ips NAB master tapes.
- Duplicated copies reproduce on $3\frac{3}{4}$ ips NAB curve or 1 $\frac{7}{8}$ ips.
- Other equalization available on request.

SIGNAL IMPEDENCE & LEVEL

- Master reproducer output: 6 volts peak-to-peak; impedance less than 10 ohms.
- Slave recorder input: 10,000 ohms nominal.

OPERATING SPEEDS

Master: 240, 120, and 60 ips.
Slave: 120, 60, and 30 ips.

FLUTTER AND WOW

Less than 0.09% RMS from 1 Hz to 300 Hz.

*TM Gauss Electrophysics, Inc.

Specifications (cont.)

SERIES 1200 ULTRA HIGH SPEED TAPE DUPLICATOR



MODE CONTROLS

ILLUMINATED momentary contact push-buttons for STOP, PLAY, FAST FORWARD and REWIND. Mode controls are interlocked. Fully remotely controllable. Solid-state switching logic.

CAPSTAN DRIVE

Closed loop, dual capstan drive – two direct-drive synchronous capstan motors.

TORQUE SYSTEM

Two non-cogging, servoed DC reel motors.

CONSTANT TAPE TENSION

Automatically controlled by servo system on both reels.

BRAKING SYSTEM

- a) Capstan motors: dynamic braking.
- b) Torque motors: combination dynamic and power-fail-safe mechanical braking.
- c) Tape idlers: mechanical.

TAPE GUIDANCE ACCURACY

Dynamic accuracy ± 0.001 inch at all speeds.

STARTING TIME TO STABLE

TAPE MOTION FOR 10½-IN. REELS

30 ips: 1 sec. max. 120 ips: 5 sec. max.
60 ips: 3 sec. max. 240 ips: 10 sec. max.

STOPPING TIME

2 seconds maximum at 240 ips with 14-inch diameter reel.

TAPE SPEED ACCURACY

$\pm 0.2\%$

REWIND / FAST FORWARD SPEED

80 seconds for 2400 feet of tape.

TAPE WIDTH

Master reproducer: ¼ inch, ½ inch or 1 inch.

Slave recorder: ¼ inch or ½ inch.

TAPE THICKNESS

From 0.0003 inch to 0.002 inch tape thickness, acetate or mylar.

REELS AND HUBS

From 7 to 14 inches in diameter, EIA or NAB.

TRACK SPACING

Standard RIAA for 2, 4 or 8 track ¼ inch and ½ inch wide tapes.

OPERATING POSITION

Horizontal or vertical.

MOUNTING

Units supplied unmounted. (An accessory console cabinet with 90° tilt for tape transport is available.)

POWER REQUIREMENTS

115 volts, 60 Hz (or 200-250v, 50 Hz), single phase 600 watts for each master reproducer or slave recorder.

WEIGHTS & DIMENSIONS – SERIES 1210 AND 1220		
Dimensions (Uncrated)	Unmounted	Mounted in Console
Height	21 in; 53.4 cm	42 in; 106.7 cm
Width	37.5 in; 95.3 cm	37.5 in; 95.3 cm
Depth	24 in; 70.0 cm	28 in; 71.2 cm
Weight (Net)	217 lbs; 98.43 KG	337 lbs; 152.9 KG
DIMENSIONS – CRATED FOR DOMESTIC OR AIR INTERNATIONAL SHIPMENT		
Height	45 in; 114.3 cm	38 in; 96.5 cm
Width	34 in; 86.4 cm	24 in; 60.9 cm
Depth	45 in; 114.3 cm	45 in; 114.3 cm
Weight (Gross)	327 lbs; 148.4 KG	Shipped unmounted only.
Console Cabinet only		
Net Weight: 130 lbs; 59.0 KG		
Gross Shipping Weight: 210 lbs; 95.25 KG		

Note – All weights & dimensions are approximate.



GAUSS ELECTROPHYSICS INC.

1653 12th Street
Santa Monica, California 90404 U.S.A. an MCA INC. company

Phone: (213) 451-9876

Cable: Gauss Santa Monica



SERIES 1200 TAPE DUPLICATOR PRODUCTION CAPACITY

The chart below will enable you to determine the number of Gauss Duplicating Slave recorders needed to produce a given number of programs on a daily schedule. Only one duplicator operator is needed to maintain this capacity with from one to ten slaves.

The high capacity of the Gauss System is based upon use of the Gauss Model 1260 Loop Bin in conjunction with the Master Reproducer operating at 240 ips. If the Loop Bin is not used, program production will be reduced by about 50% depending upon whether or not a multiple master tape is employed.

The figures in Column #7 allow fifteen seconds to reload each slave with blank tape, and are based upon using 3,600 ft. pancakes. A five to ten percent production increase can be achieved if 7,000 ft. pancakes are used.

(1) FINAL TAPE FORMAT	(2) PLAY TIME (AVERAGE)	(3) PLAY SPEED OF COPY	(4) MASTER TAPE TRACKS/ LENGTH	(5) MASTER TAPE RUN TIME AT 240 IPS	(6) NO COPIES PER SLAVE PER HOUR	(7) NUMBER COPIES PRODUCED PER SLAVE EACH 8 HOUR SHIFT	(8) DAILY PRODUCTION
8 track Lear Jet	30 min.	3¾ ips.	8-track 300 ft.	15 sec.	228	1824 x No. of Slaves =	
4 track Cartridge	30 min.	3¾ ips.	4-track 600 ft.	30 sec.	108	864 x No. of Slaves =	
4 track R. to R.	30 min.	3¾ ips.	4-track 600 ft.	30 sec.	108	864 x No. of Slaves =	
4 track Philips Cassette	C-30 30 min.	1⅞ ips.	4-track 600 ft.	30 sec.	117	936 x No. of Slaves =	
4 track Philips Cassette	C-60 60 min.	1⅞ ips.	4-track 1200 ft.	60 sec.	58	464 x No. of Slaves =	

MODEL 1260 HIGH SPEED – HIGH CAPACITY ENDLESS TAPE LOOP BIN



Model 1260 High Speed – High Capacity Endless Tape Loop Bin



Model 1260 in console cabinet.

ADVANCED FEATURES

- HIGH CAPACITY—UP TO 1800 FOOT MASTERS
- 240, 120 AND 60 IPS ELECTRICALLY SELECTED SPEEDS
- HI-RELIABILITY INTEGRATED CIRCUIT LOGIC—NO RELAYS
- ELIMINATES MULTIPLE COPY MASTER TAPES
- PRODUCTION INCREASED BY 25 TO 100% ON ANY DUPLICATOR
- AUTOMATES ANY HIGH SPEED DUPLICATION SYSTEM

The Gauss Model 1260 Endless Tape Loop Bin combines an entirely new, high capacity, high speed loop bin with a fully automatic, digital control system and provides a 25 to 100 percent increase in the production capacity of any high speed duplicator. In a typical situation* the Gauss 1260 will increase duplicator production from 30 to 55 copies/hour/slave—an improvement of more than 80 percent. The 1260 also provides significant cost savings by eliminating the need for multiple program master tapes.

The Model 1260 consists of Gauss' revolutionary three-speed loop bin mounted horizontally in its console and combines a digital integrated circuit (I.C.) control system. The 1260 is used with a master duplicator transport so that its loop bin functions as the master tape supply, and the entire duplication system is directed by an Automatic Command Unit.

*Dubbing a 1200' master tape at 240 ips to produce 300' copies for 1 1/2 ips playback. In conventional reel-to-reel duplication, this dubbing operation takes 60 seconds, and one minute is required for master rewind and for slave respooling. Production is 30 copies/hour/slave. The Gauss 1260 permits stagger reloading of the slaves and the use of up to 7,200 foot (14 in. reel) pancakes. Each slave, therefore, can run continuously, with a downtime of only 60 seconds (or the length of one program dub) allowed for respooling. With the 1260, production is therefore increased to 55 copies/hour/slave.

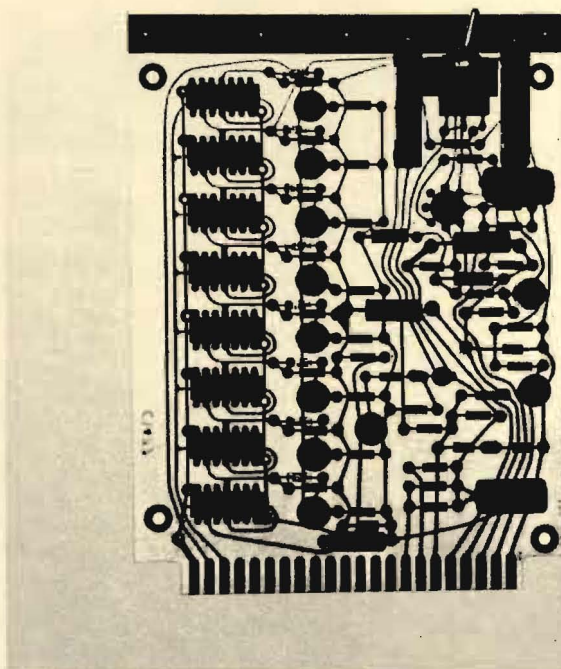

Integrated circuit logic module.

The 1260 can be used with the Gauss Series 1200 or G12 Ultra High Speed Tape Duplicator or with any existing duplication equipment. With 3 selectable speeds (240, 120 and 60 ips), the 1260 assures compatibility with any high speed duplication system. However, when used with the Series 1200 Duplicator at 240 ips, the 1260 Loop Bin alone provides 100 percent production increase over any other duplication system. The 1260 Endless-Loop Bin is also an ideal data storage system for numerous other applications such as data analysis, annunciation, simulation and process control.

THE ENDLESS-LOOP BIN

The heart of the Model 1260 is the Gauss Pneumatic Endless-Loop Bin. New developments incorporated in the Model 1260 for the first time permit high speed operation with an 1800 foot long program.

Gentle tape handling is assured with any program length from 10 to 1800 feet. Control of tape movement is pneumatic with the tape actually cushioned by air. Thus, the tugging, pulling, creasing and edge-damage typical of vertical "force-pull" bins does not occur in the 1260.

Tape movement is controlled by means of a precision capstan and speed/tension system. The capstan can be operated in "servo" mode where it provides constant tape tension for the master transport which in turn controls the tape speed accuracy. Operated in non-servo mode, the 1260 maintains tape speed accuracy for operation independent of the master transport.

Flutter isolation of the bin from the master transport is assured by a multi-stage flutter filter system. Hence, over-all flutter specifications of high quality open-loop or closed-loop audio transports will not be degraded.

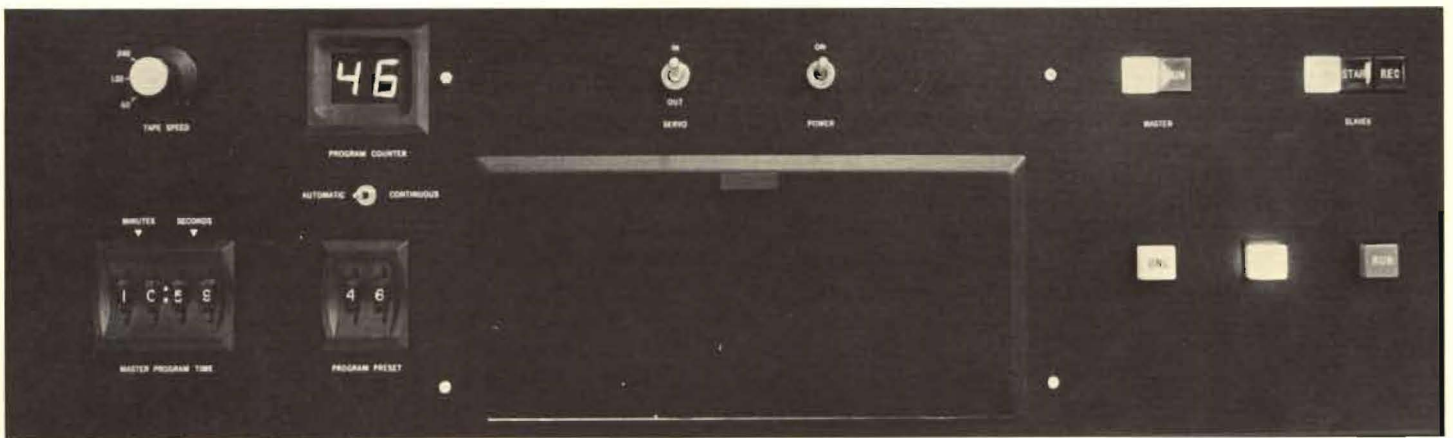

System control panel (integrated circuit logic).

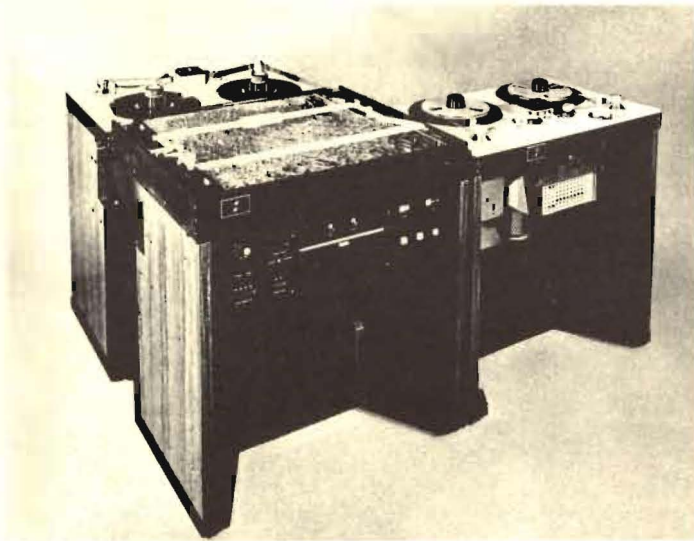

A basic Series 1200 system (Loop Bin, Master Reproducer, Slave Recorder).

OTHER APPLICATIONS

The Gauss Model 1260 Endless-Loop Bin can be used in many other applications including data analysis, annunciation, simulation and process control. Complicated moving head transports are no longer required for wideband data analysis, since the high speed and tape capacity capabilities of the 1260 lend themselves directly to repetitive data analysis applications such as those using cross-correlation and inter-correlation techniques. In annunciation systems, the bin can be used for recording random events and then dubbing them onto a reel-to-reel recorder for later analysis. The 1260 can also be used to control equipment such as a vibration table for rocket flight simulation, or it might be used in the process control system of a petrochemical plant. The Model 1260 can be provided in special configurations with speeds from very slow to over 300 ips.

THE AUTOMATIC CONTROL SYSTEM

The Automatic Control Unit is a completely solid-state, digital programmer which automatically sequences the duplicator master and slave transports. The system can operate in either of two modes: "Synchronized" or "Stagger Load."

In "Synchronized" operation, the master transport's "tape speed" is selected on the control panel, and the "master program time," (the length of the master program) is set. The operator also enters the "program preset" number—the number of programs to be copied on the slaves before the system stops for respooling. Depressing the "run" button starts the transports, and the program automatically begins the instant all slaves have attained proper speed, thus minimizing tape waste. The "program count" (the number of programs recorded on the slaves at any moment) is continuously displayed on the control panel, and the slaves automatically stop for respooling after the



Tilted for access.

preset number of programs has been recorded.

In the "stagger-load" mode, each slave in the system may be started sequentially one or more programs later than the prior slave. Each slave will then exhaust its tape supply at intervals equal to those used in the starting sequence. Any slave may be taken "off line" at any time for respooling. Since the 1260 automatically compensates for start time, the slave will then automatically start in its turn while other slaves in the system continue producing. Operation in "stagger-load" mode can provide an average of 15 percent improvement in production capacity over "synchronized" mode.

The Automatic Control Unit also includes functions for loading and unloading tape from the bin to facilitate storage of the master tape on a reel. Loading and unloading is quickly accomplished at 240 ips. The operating status of the entire duplicator is continuously displayed on the front panel indicators allowing for continuous operator verification.

FLEXIBILITY AND VERSATILITY

The Model 1260 is housed in a rugged console cabinet with the endless-loop bin mounted horizontally. Installation requires only that the 1260 be placed at the back of the master transport with the bin's tape path at the same height as the master. The control electronics are easily connected to the master transport's remote control lines. In general, the entire installation can be completed in less than two hours.

The endless-loop bin is available for either ½ or 1 inch wide tape. Since the 1260 has its own independent control system, it can be used with almost any tape transport, whether digital, audio, instrumentation or video. With three selectable speeds (240, 120 and 60 ips), it makes copies from virtually any master.

PRODUCTION EFFICIENCY

Use of the Gauss Model 1260 will generally double the production capacity of any existing duplicator by continuous running of the master tape without rewinding. When used with the Gauss 1200 Duplicators at 240 ips, the 1260 will *again double* the duplication output. In addition, if "stagger load" mode is employed, a further 15 percent increase can be realized.

This vastly increased efficiency means that—for a given production goal—less machines are required, resulting in less capital investment, less maintenance costs and lower overhead.

SERVICE AND RELIABILITY

The Model 1260 is designed to provide the user with maximum reliability and ease of servicing.

It is fully modular in design. The bin base plate provides a massive, precision-mounted surface with heavy ribbing to assure a perfectly stable tape guiding plane. The entire bin tilts up in its console allowing access to the drive system and logic if servicing is necessary. All mechanical components are readily accessible and can be installed without special tools and procedures.

Ultra reliable solid-state integrated circuitry is employed throughout. There are no relays in the Model 1260. Modular, plug-in, printed circuit cards are used.

PERFORMANCE SPECIFICATIONS

The Gauss Model 1260 has been designed to provide from 25 to 100 percent improvement in the production capacity of any high speed duplicator. It combines an entirely new, high speed, high capacity, 3-speed, pneumatic, endless-loop bin with a fully digital integrated circuit command system. Mounted horizontally in its own console cabinet, it may be installed with new or existing equipment. The 1260 can also be used in many other applications, including data analysis, annunciation, simulation and process control.

MECHANICAL

Speeds...3 electrically selected speeds: 240, 120, and 60 ips standard. Others from very slow to over 300 ips on special order.

Tape Capacity...continuous tape loops from 10 to 1800 feet. Other lengths available on special order.

Tape Width... ½ or 1 inch.

Type of Tape... ½ or 1 inch wide, 1½ mil thick polyester backed (for optimum results). Oxide formulation non-critical.

Flutter and Wow...will not degrade master transport flutter specifications.

Tape Tension...independent servo system provides constant tension between bin and master transport.

Start Time...less than 2 secs. or limited by master transport.

Tape Life...2000 passes minimum. Life commensurate with that obtained on a quality reel-to-reel duplicator.

ELECTRONIC

Operating Controls... "RUN" – automatically loads bin, and/or starts duplicator system.

"STOP" – stops entire system.

"UNLOAD" – allows rewind of tape onto a reel to unload bin.

"SERVO IN/OUT" – selects whether capstan provides constant tape tension or fixed tape speed.

"MASTER PROGRAM TIME" – thumbwheels permit entry of length of endless loop program.

"PROGRAM PRESET" – thumbwheel selects number of copies slaves are to record before automatically stopping.

"TAPE SPEED" – three speed selector.

"POWER" – On/Off

Indicators... "PROGRAM COUNT" – gives digital readout of number of copies slaves have recorded during each run. Master; Status "Stop" and "Run"

Slave; Status "Stop", "Start" and "Record".

Connectors... MS type selected to mate with Series 1200 Duplicator. Normally open, momentary contact closure. Circuits for control of start/stop functions in master and start/stop/record in slaves.

Logic... Automatically starts, stops and sequences master and all slave transports in duplicator.

Electronics... All solid-state circuits built on highest quality modular, plug-in printed circuit boards. Integrated circuits for digital count and timing functions. No relays used.

POWER

Voltage...100 to 250 V.A.C.

Frequency... 60 or 50 Hz.

MOUNTING

Loop bin horizontally mounted in adjustable console with Automatic Control Unit mounted for front access to controls.

OPERATING ENVIRONMENT

Temperature...15° to 40°C

Humidity...20 to 95% relative humidity

Altitude... to 10,000 feet

MODEL 1260		
Dimensions (Uncrated)	Unmounted	Mounted In Console
Height	16½ in; 41.91 cm	42 in; 106.68 cm
Width	37½ in; 95.25 cm	39¼ in; 99.70 cm
Depth	31¼ in; 79.38 cm	31¼ in; 79.38 cm
Weight (net)	185 lbs; 84 KG	315 lbs; 143 KG
DIMENSIONS (CRATED) FOR DOMESTIC OR AIR INTERNATIONAL SHIPMENT		
Height	26¾ in; 67.95 cm	
Width	45¾ in; 116.20 cm	
Depth	45¾ in; 116.20 cm	
Weight (Gross)	348 lbs; 159 KG	

Note: All weights and dimensions are approximate.



GAUSS ELECTROPHYSICS INC.

1653 12th Street
Santa Monica, California 90404 U.S.A. an MCA INC. company

Phone: (213) 451-9876

Cable: Gauss Santa Monica

MARTIN AUDIO
SONOMIX

**THE MOST VERSATILE,
MOST USEFUL
AUDIO MIXER
EVER MADE**

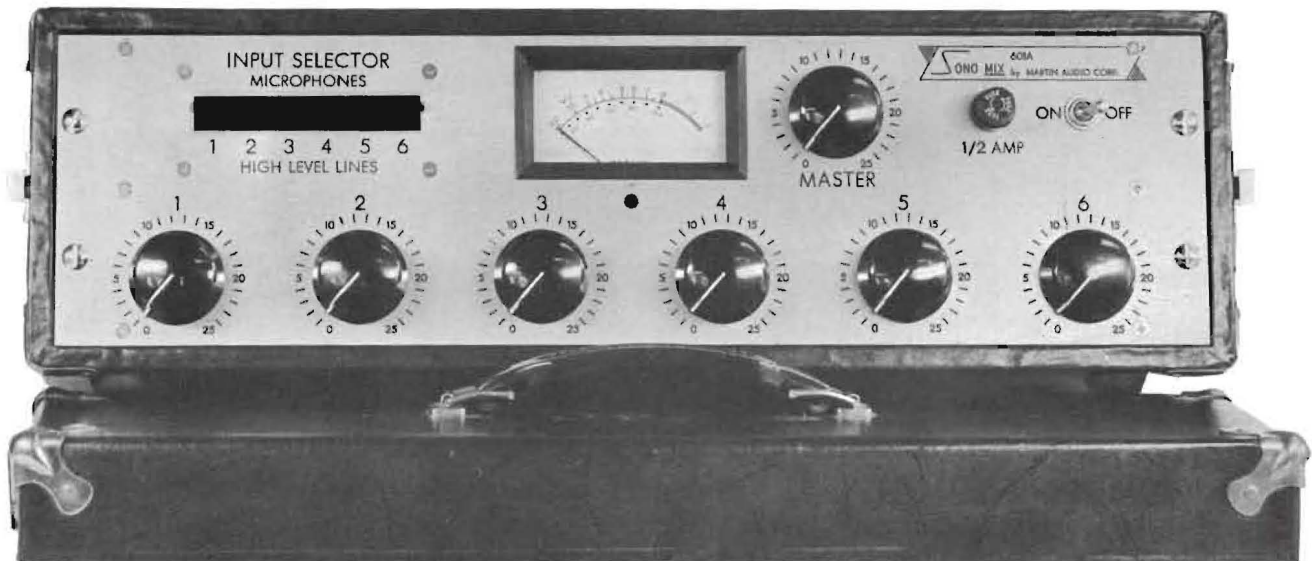

- 6 channels — switchable line and mike input.
- AC or Nickle-Cadmium battery operation.
- High gain — low noise solid state circuitry.
- Lightweight — Compact — Portable.



MARTIN AUDIO CORPORATION

56 West 45th Street • New York, N. Y. 10036 • (212) 661-6987

TAKE THE SONOMIX ANYWHERE...

use 6 inputs from any source, through any kind of audio system.



Put the Sonomix to work for you on any assignment — studio or location. Take advantage of its unmatched versatility with up to six inputs, switchable in any combination between line and mike sources. Use AC power or

Nickle-Cadmium battery—built-in rechargeable pack will power the Sonomix for more than 30 hours, re-charges overnight without danger of overcharge through built-in current limiter.

BUILT FOR ROUGH LOCATION OPERATION

The Sonomix was conceived as a location unit, and was designed and built with extra-rugged features for dependable operation under the most difficult field conditions. All electrical and mechanical components are of highest industrial quality to resist effects of vibration, shock,

heat and humidity. Printed circuit cards are gold-plated, built of warp-resistant epoxy-glass. Audio transformers are hermetically sealed. Transistors and capacitors are epoxy-dipped to resist moisture; resistors and controls are hot-molded for the utmost reliability.

EASY TO WORK WITH

The Sonomix is compact . . . but not cramped. Plenty of room around each mixing pot, to give your hand 'breathing space' — lets you respond quickly to changes in level. Mike and output connectors are standard profes-

sional-type, plug in directly, disconnect quickly. Large Weston VU meter gives you accurate readings at a glance. And controls are labeled with large engraved markings—can't rub off, stand out brightly even in dim light.

PROVEN DESIGN

Components of the Sonomix are identical to those employed in custom units built by the Martin Audio Corp. over a five-year period. Although 'packaged' in a new layout for the Sonomix, the basic circuitry and electronic

design is actually the product of a long and stringent period of development . . . having proven itself on the job in film locations, broadcast and recording studios, and in theatre and public address applications.

GUARANTEED FOR A FULL YEAR

All components of Martin Audio manufacture or assembly are guaranteed to meet specifications under normal studio or field conditions for one year. VU meter and Nickle-Cadmium battery pack carry manufacturers' 90-

day guarantee, and will be repaired or replaced free of charge by Martin Audio during this period. The foregoing guarantees assume that the respective units have not been modified or given unauthorized repair.

TAILOR THE SONOMIX TO YOUR NEEDS...

in each configuration, it out-performs any mixer in its field.

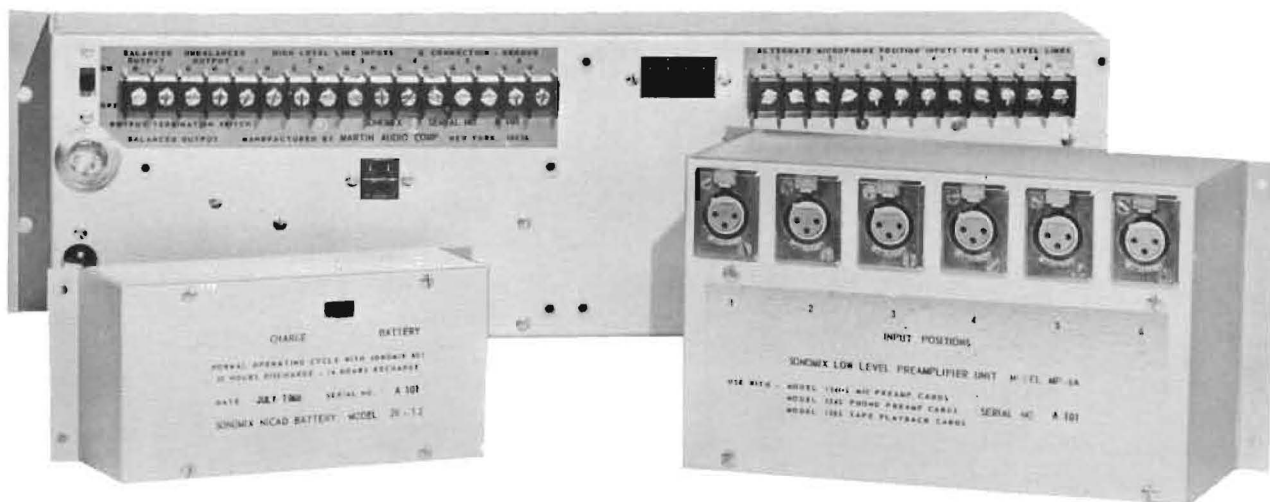

PLUG-IN COMPONENTS 'BUILD' THE SONOMIX THAT SUITS YOU BEST

The Sonomix consists of four basic components, and may be ordered in any combination of the four. These are: line mixer with AC Power Supply; Preamplifier unit

with up to six mike, magnetic tape or phono cartridge preamps; Nickle-Cadmium battery pack; and portable case, which holds all units for travel or location use.

MODULAR CONSTRUCTION

The Sonomix is designed for all-round simplicity — of maintenance, as well as operation. All amplifier units are built on individual circuit boards . . . each simply plugs

in for quick, low-cost service or replacement. Mike pre-amp assembly and battery pack may be added or removed easily, whenever required.

COMPARE THE SPECIFICATIONS...THE SONOMIX IS BUILT TO EXCEED MOST REQUIREMENTS

- Inputs** 6 Microphone level inputs switchable by front panel keys to 6 high level line inputs.
- Input Impedances** Microphone-200 OHMS balanced will match Mikes 30 to 1000 OHMS.
Line-100K OHMS isolated unbalanced bridge.
- Output Impedance** Balanced 600 OHMS, Unbalanced 10K OHMS.
- Output** 600 OHMS, maximum level + 16DBM.
- Noise Level** Equivalent input noise —127 DBM. Output noise —85 DBM with master gain control closed.
- Frequency Response** ± 1DB 30-20,000 HZ.
- Distortion** Less than 25% THD at maximum output
- Controls** 6 mixer level, 1 master level and a 6 mike-line selector switches (for switching mike to line or intermix).
- Connectors** 6 female cannon type XL connectors for microphones, 1 male cannon XL for balanced output. Line input, balanced output and high impedance output are on screw terminal strip.
- Power Requirement** 117 volts AC. 50/60 HZ or 20 VDC 40 MA.
- Nickle Cadmium Pack** 20 volts at 1.25 amps/hours. Will operate the Sonomix for more than 30 hours. Built-in charger.
- Gain** 96 DB maximum from Mike inputs, 30 DB maximum from line inputs.
- Size** 5¼ x 19 x 7½ inches
- Weight** Basic mixer 7 lbs. Mike preamplifier unit 2½ lbs.; Ni-cad pack 2½ lbs.; Case — 7 lbs.

ALL MARTIN AUDIO DESIGNS HAVE ONE FEATURE IN COMMON.

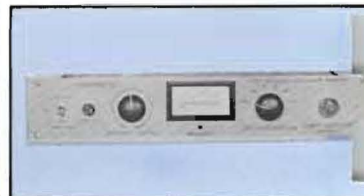
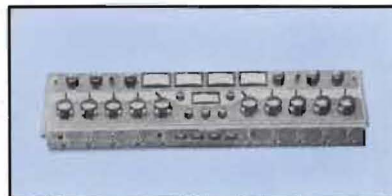
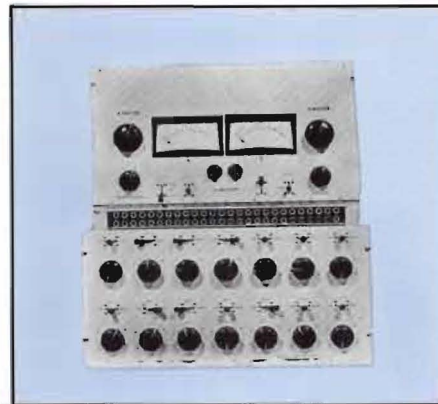
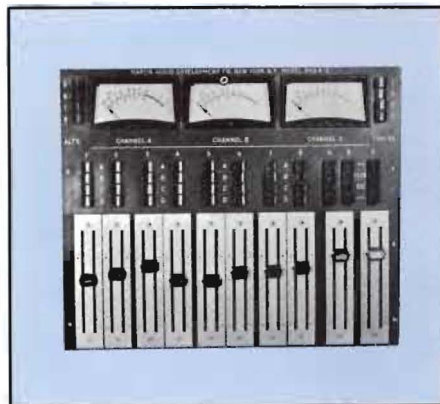

The operator's requirement is the first consideration in all the products manufactured by Martin Audio . . . designs conceived from the recording engineer's point-of-view for the most straightforward, efficient operation.

The reason is simple. In addition to craftsmen of the highest technical skill, Martin Audio's staff includes experienced audio operators, with extensive credits as professional sound engineers. Thus, precision workmanship combines with a first-hand understanding of the qualities vital to the men who work with audio equipment.

Just as these concepts extend the capabilities of the Sonomix, they also enhance many custom consoles, complete audio systems, and control rooms built by Martin Audio for major recording, broadcasting and motion picture studios.

Martin Audio is equipped to offer you expert, professional service in any area of audio endeavor — from the smallest technical problem to the design and installation of a complete sound studio.



Martin Audio Corporation • 56 West 45th Street
New York, N. Y. 10036 • (212) 661-6987

When you can control running speed, you'll

Get New Uses From Your Tape Recorder

Varispeed III gives you that control...and more!



Useful in many ways... Varispeed III lets you:

- Correct tapes recorded off-speed by increasing/decreasing speed.
- Create Sound effects... alter 'live' sounds to suit you.
- Half-speed your recorder for double the recording time.
- Perform variable-delay recording for Satellite — Land synchronization of international telecasts.
- Drive 50-cycle (European) recorder on 60-cycle AC; Drive 60-cycle (American) recorder on 50-cycle AC.
- Transfer film tracks from 50-to 60-cycle standards for exact resolution of your European tracks.
- Create electronic music by changing pitch, quality of instruments and voices.

For corrective work... for creative work... put the Varispeed III to work for any application demanding physical alteration of tape speed. Simple-to-use unit requires no modification to your equipment — simply acts as a precisely-controlled variable frequency AC power source for the tape recorder capstan motor; exact frequency is read from large meter. Mounts in standard rack, requires no special care or ventilation. Generates very little heat, connects with equipment through standard capstan interlock connector.

Varispeed III is a high-efficiency solid state unit using integrated circuits and high-voltage power transistors. It consists of a low frequency oscillator and 120V power amplifier, and plugs directly into Scully 280, or Ampex 300, 350 and 440 studio recorders, and can be adapted to most other studio recorders (can also be connected with Martin Audio Model DM film demodulator for magnetic sync transferring). Frequency can be swept from 25 to 80 cps... or synchronized at 30, 48, 50 and 60 cycles for precise frequency calibrations. Price: \$395.00 with standard connecting cable for Ampex and Scully.

SPECIFICATIONS

Frequencyvariable from 25 to 80 HZ.
Output1 amp 120V AC.
ControlsFrequency — off-on switch.
Power Requirements1.0 amps 50 — 400 cycle AC.
Size3½ x 19 panel mount 6" depth behind panel.
Accessoriesconnection is available for Martin Audio Model DM film demodulator.



MARTIN AUDIO CORPORATION

56 West 45th Street • New York, N. Y. 10036 • (212) 661-6987

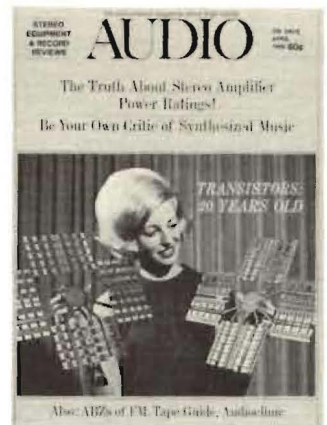
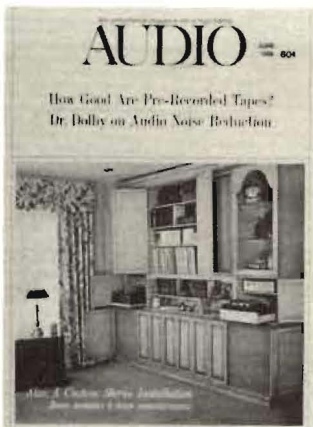

AUDIO

at

SHOW SAVINGS

**A special introductory offer
for visitors at the Show**

**Every issue is devoted to making
sound reproduction more meaningful . . .
keeps you abreast of the latest equipment
advances and new audio techniques,
plus record and tape reviews.**

Save now . special offer . Audio magazine

North American Publishing Co. / 134 N. 13th St. / Philadelphia, Pa.

**Please send me Audio
at the special show rate:**

- one year \$3.00** (regular \$5.00)
 two years \$5.00 (regular \$9.00)
 three years \$7.50 (regular \$12.00)

Name _____

Address _____

City _____

State _____ Zip _____

Bill me

Payment enclosed

**Subscribe Now.
Save on this
special introductory offer.**

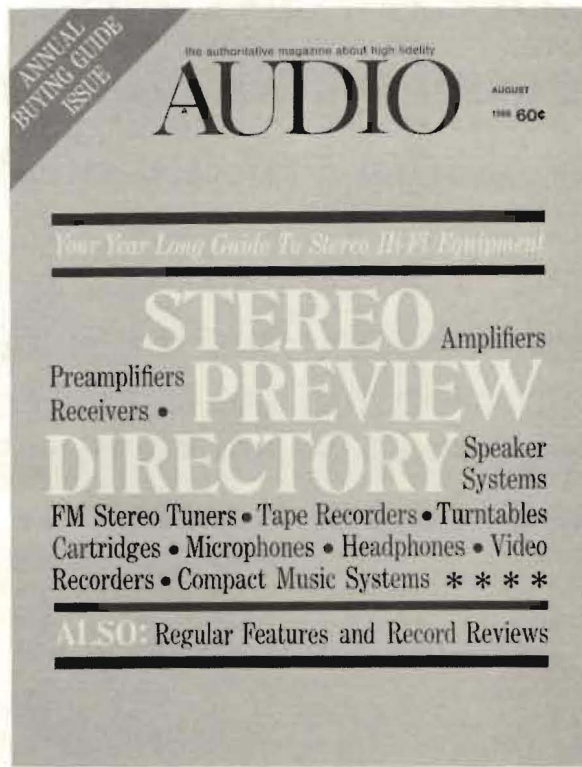

FIRST CLASS
Permit No. 22,489
Philadelphia, Pa.

BUSINESS REPLY MAIL
No Postage Necessary if Mailed in the United States

POSTAGE WILL BE PAID BY:

Audio
134 North Thirteenth St.
Philadelphia, Pa. 19107

ANNUAL
BUYING GUIDE
ISSUE

the authoritative magazine about high fidelity

AUDIO

AUGUST

1968 60¢

Your Year-Long Guide To Stereo Hi-Fi Equipment

STEREO Amplifiers Preamplifiers Receivers • PREVIEW DIRECTORY Speaker Systems

FM Stereo Tuners • Tape Recorders • Turntables
Cartridges • Microphones • Headphones • Video
Recorders • Compact Music Systems * * * *

ALSO: Regular Features and Record Reviews

AUDIO

the authoritative magazine
about high fidelity

134 NORTH THIRTEENTH STREET
PHILADELPHIA, PA. 19107
TELEPHONE 215-564-5170

SALES OFFICES

SANDY CAHN, MKTG. DIR.
663 Fifth Avenue
New York, N.Y. 10022
(212) 753-8824

LOU WEBER
5201 N. Harlem Avenue
Chicago, Illinois 60656
(312) 775-0755

JAY MARTIN
9350 Wilshire Boulevard
Beverly Hills, Calif.
(213) 273-1495