

VitalCare™
506N3 Series
Patient Monitor
Service Manual

Cat. No. 1446
Date 08/07

CE 0413
Part No. 39178B101
Revision 1

Copyright

COPYRIGHT © CRITICARE SYSTEMS, INC., 2007

CRITICARE SYSTEMS, INC. (Criticare) owns all rights to this unpublished work and intends to maintain this work as confidential. Criticare may also seek to maintain this work as an unpublished copyright. This publication is to be used solely for the purposes of reference, operation, maintenance, or repair of Criticare equipment. No part of this publication may be reproduced in any manner or disseminated for other purposes.

In the event of inadvertent or deliberate publication, Criticare intends to enforce its rights to this work under copyright laws as a published work. Those having access to this work may not copy, use, or disclose the information in this work unless expressly authorized by Criticare to do so.

All product specifications, as well as information contained in this publication, are subject to change without notice.

All information contained in this publication is believed to be correct. Criticare Systems, Inc., shall not be liable for errors contained herein nor for incidental or consequential damages in connection with the furnishing, performance, or use of this material.

This publication may refer to information and products protected by copyrights or patents and does not convey any license under the patent rights of Criticare Systems, Inc., nor the rights of others. Criticare Systems, Inc., does not assume any liability arising out of any infringements of patents or other rights of third parties.

PROPERTY OF CRITICARE SYSTEMS, INC. ALL RIGHTS RESERVED

DOX™ oximetry and ComfortCuff™ NIBP technology are trademarks of Criticare Systems, Inc.

OxiMax® SpO₂ technology is a registered trademark of Nellcor Puritan Bennett Inc.

FILAC® and FasTemp® are registered trademarks of TYCO Healthcare.

TurboTemp® is a registered trademark of Cardinal Health, Inc.

Contents

| | |
|-----------------------------|-----|
| Copyright | ii |
| Contents | iii |
| Warranty | ix |
| Service Return Policy | x |
| EC Declaration | xi |

Section 1 — Introduction

| | |
|---|------|
| Description | 1-1 |
| Intended Use | 1-2 |
| About this Manual..... | 1-2 |
| Non-Invasive Blood Pressure (NIBP) | 1-3 |
| Comfort Cuff Technology..... | 1-3 |
| Description of NIBP Measurement | 1-3 |
| Cuff Inflation and Pressure Protection | 1-4 |
| Heart Rate | 1-5 |
| DOX Pulse Oximetry Measurement (SpO ₂) | 1-5 |
| Definition..... | 1-5 |
| DOX Digital Oximetry..... | 1-5 |
| Method..... | 1-6 |
| SpO ₂ Clinical Testing and Accuracy..... | 1-6 |
| Nellcor Pulse Oximetry Measurement (SpO ₂)..... | 1-7 |
| Definition..... | 1-7 |
| Method..... | 1-7 |
| Automatic Calibration..... | 1-8 |
| Accuracy of OxiMax Sensors..... | 1-8 |
| Functional versus Fractional Saturation | 1-8 |
| Measured versus Calculated Saturation | 1-9 |
| Temperature..... | 1-10 |
| Predictive Mode | 1-10 |
| Continuous Mode..... | 1-11 |
| Axillary Measurements | 1-11 |
| Clinical Testing and Accuracy..... | 1-11 |
| Specifications | 1-12 |
| Symbols..... | 1-16 |
| Safety | 1-18 |
| Software Error Related Hazard Mediation | 1-19 |
| Potential Interference..... | 1-19 |
| Leakage Current | 1-19 |
| Voltage Fluctuations | 1-20 |
| Defibrillation, HF, and Electronic Device Protection | 1-20 |
| Biocompatibility..... | 1-20 |
| Latex Content | 1-20 |
| DEHP Content | 1-20 |

Section 2 — Service Menus

| | |
|----------------------------------|------|
| Introduction | 2-1 |
| Service Mode | 2-1 |
| Service Menu | 2-1 |
| Primary Service Displays | 2-1 |
| Secondary Service Displays | 2-2 |
| Service Display List | 2-2 |
| Self Tests | 2-4 |
| NIBP Calibration Mode | 2-6 |
| LCD Text Display | 2-7 |
| Using the Menu | 2-7 |
| Exit the Menu | 2-7 |
| Factory Defaults | 2-8 |
| Alarm Menu | 2-8 |
| Parameter Setup | 2-8 |
| Printer Setup | 2-9 |
| Configuration Menu | 2-9 |
| NIBP Cycle Menu | 2-9 |
| Trend Menu | 2-10 |
| Patient Menu | 2-10 |
| User Defaults | 2-10 |
| Setting User Defaults | 2-10 |
| Power Up in Service Mode | 2-11 |
| Saving Unit Defaults | 2-11 |
| Alarm Menu | 2-13 |
| Alarm Volume | 2-13 |
| Pulse Volume | 2-13 |
| High Pulse | 2-14 |
| Low Pulse | 2-14 |
| High SpO ₂ | 2-14 |
| Low SpO ₂ | 2-14 |
| High Systolic | 2-14 |
| Low Systolic | 2-14 |
| High Diastolic | 2-14 |
| Low Diastolic | 2-14 |
| High MAP | 2-14 |
| Low MAP | 2-14 |
| High Temperature | 2-15 |
| Low Temperature | 2-15 |
| Parameter Setup Menu | 2-15 |
| Temperature Mode | 2-15 |
| Degrees F/C | 2-15 |
| SpO ₂ Search | 2-15 |
| NIBP Tone | 2-15 |
| SpO ₂ Average | 2-15 |
| Printer Setup Menu | 2-16 |
| On NIBP | 2-16 |
| On Alarm | 2-16 |
| Interval | 2-16 |
| Print To | 2-16 |
| Serial | 2-16 |
| Baud Rate | 2-16 |

| | |
|--|------|
| Configuration Menu | 2-17 |
| Date | 2-17 |
| Time | 2-17 |
| Hour | 2-17 |
| Minute | 2-17 |
| Day | 2-17 |
| Month | 2-17 |
| Year | 2-17 |
| Contrast | 2-17 |
| Temperature | 2-17 |
| SpO ₂ | 2-17 |
| NIBP | 2-17 |
| Enable MAP | 2-17 |
| International Configuration Settings | 2-18 |
| Language | 2-18 |
| Trend Button Settings | 2-18 |
| Interval | 2-18 |
| Format | 2-18 |
| Span | 2-18 |
| Patient Button Settings | 2-18 |

Section 3 — Theory of Operation

| | |
|-------------------------------|-----|
| System Architecture | 3-1 |
| Module Architecture | 3-2 |
| Main Board | 3-2 |
| Display Board | 3-2 |
| NIBP Module | 3-3 |
| DOX Module | 3-3 |
| Nellcor Module | 3-3 |
| Nellcor Carrier Board | 3-3 |
| Temperature Modules | 3-4 |
| FasTemp Isolation Board | 3-4 |
| Printer Module | 3-4 |
| Block Diagram | 3-5 |

Section 4 — Cleaning and Disinfecting

| | |
|-------------------------------------|-----|
| Cleaning and Disinfecting | 4-1 |
| Blood Pressure Cuffs | 4-1 |
| DOX Pulse Oximeter Sensors | 4-2 |
| OxiMax Pulse Oximeter Sensors | 4-2 |
| Temperature Probes | 4-4 |
| Accidental Wetting | 4-5 |

Section 5 — Preventative Maintenance

| | |
|---|------|
| Incoming Inspection..... | 5-1 |
| Maintenance Schedule | 5-1 |
| Long-Term Storage..... | 5-1 |
| Service Checks..... | 5-1 |
| Calibration..... | 5-1 |
| Serviceable Components..... | 5-2 |
| Battery Removal/Replacement | 5-2 |
| Fuse Removal/Replacement..... | 5-4 |
| Annual Testing..... | 5-5 |
| Accessory Testing..... | 5-5 |
| Functional and Safety Testing..... | 5-5 |
| Equipment and Tools | 5-6 |
| Test Fixtures | 5-7 |
| Electrical Safety Tests | 5-10 |
| Withstanding Voltage Test (Hi-Pot)..... | 5-10 |
| Equipment Needed | 5-10 |
| Setup Hi-Pot Tester..... | 5-10 |
| Hi-Pot Performance Test..... | 5-11 |
| Leakage Testing..... | 5-13 |
| Setup Procedure (Self-Test) | 5-13 |
| Leakage Procedure..... | 5-14 |
| Functional Tests | 5-16 |
| System Check..... | 5-16 |
| Speaker Performance, Alarms Verification | 5-17 |
| Power Supply Performance | 5-18 |
| Printer Performance..... | 5-18 |
| Monitoring Module Verification | 5-19 |
| NIBP Verification | 5-19 |
| NIBP Seal Test..... | 5-20 |
| SpO ₂ Verification: CSI DOX Only | 5-21 |
| SpO ₂ Verification: Nellcor Only..... | 5-21 |
| Temperature Verification..... | 5-23 |
| Functional and Safety Testing Checklist..... | 5-25 |

Section 6 — Service Testing & Calibration

| | |
|--|-----|
| Monitor Testing..... | 6-1 |
| Service Checks | 6-1 |
| Field Service Testing | 6-1 |
| Equipment and Tools | 6-2 |
| Communication Testing..... | 6-3 |
| Equipment Required | 6-3 |
| Pinout Chart | 6-3 |
| Procedure..... | 6-3 |
| DOX SpO ₂ Performance Testing..... | 6-4 |
| Programming the SmartSat Analyzer..... | 6-4 |
| Test Procedure..... | 6-4 |
| Nellcor SpO ₂ Performance Testing | 6-5 |
| Programming the SmartSat Analyzer..... | 6-5 |
| Test Procedure..... | 6-5 |

| | |
|---|------|
| NIBP Calibration | 6-6 |
| Equipment Required | 6-6 |
| Installing the PC Service Program | 6-6 |
| Configuring the Ports | 6-6 |
| Setup | 6-7 |
| Calibrate | 6-8 |
| Safety Test..... | 6-11 |
| Speed Test | 6-14 |
| Leak Test..... | 6-16 |
| Accuracy Test | 6-20 |
| Other Module Testing and Calibration..... | 6-22 |

Section 7 — Disassembly

| | |
|--|------|
| Before You Begin | 7-1 |
| Service Safety..... | 7-1 |
| Electrostatic Discharge Protection..... | 7-2 |
| Tools Needed | 7-2 |
| Replace the Printer..... | 7-3 |
| Replace the Temperature Boards | 7-5 |
| Replacing the FasTemp Isolation Board..... | 7-6 |
| Replacing the FasTemp Board | 7-8 |
| Replacing the TurboTemp Board..... | 7-12 |
| Replace the SpO ₂ Board..... | 7-13 |
| DOX SpO ₂ with TurboTemp or without Temperature | 7-14 |
| DOX SpO ₂ with FasTemp..... | 7-15 |
| Nellcor SpO ₂ PCB/Carrier Board with TurboTemp or without Temperature..... | 7-18 |
| Nellcor SpO ₂ with FasTemp | 7-19 |
| Front Bezel Service | 7-22 |
| Disassemble Front Bezel from Rear Housing..... | 7-22 |
| Replace Main Board | 7-24 |
| Replace Speaker | 7-29 |
| Replace LCD and LED Display Boards | 7-31 |
| Replace Membrane | 7-35 |
| Chassis Service/Pump Disassembly | 7-39 |
| Replace ComfortCuff NIBP Module | 7-41 |
| Replace Power Supply | 7-42 |
| Completion of Service | 7-43 |

Section 8 — Troubleshooting

| | |
|-----------------------------|-----|
| Troubleshooting Guide | 8-1 |
|-----------------------------|-----|

Section 9 — Drawings and Schematics

| | |
|-----------------------------|------|
| List of Drawings | 9-1 |
| Assembly Parts Lists | 9-1 |
| PCB Drawing List | 9-2 |
| Final Assemblies | 9-3 |
| 506DN3 | 9-3 |
| 506DNP3 | 9-3 |
| 506DNT3 | 9-4 |
| 506DNTP3 | 9-5 |
| 506LN3 | 9-5 |
| 506LNP3 | 9-6 |
| 506LNT3 | 9-7 |
| 506LNTP3 | 9-8 |
| 506DNV3 | 9-9 |
| 506DNVP3 | 9-9 |
| 506LNV3 | 9-10 |
| 506LNVP3 | 9-10 |
| 506N3 | 9-11 |
| 506NP3 | 9-11 |
| 506NT3 | 9-12 |
| 506NTP3 | 9-12 |
| 506NV3 | 9-13 |
| 506NVP3 | 9-13 |
| Base Assemblies | 9-14 |
| Without Temperature | 9-14 |
| With Temperature | 9-14 |
| NIBP Only | 9-15 |
| NIBP/TEMP | 9-15 |
| Front Bezel | 9-16 |
| Non-Temperature | 9-16 |
| Temperature | 9-16 |
| NIBP Only | 9-17 |
| NIBP/TEMP | 9-17 |
| Rear Housing Assembly | 9-18 |
| Chassis Assembly | 9-18 |
| NIBP | 9-19 |
| Module | 9-19 |
| Pneumatic | 9-19 |
| PCB Assembly | 9-20 |
| Printer Assembly | 9-20 |

Appendix A — Main Board Upgrades

| | |
|--|-----|
| Overview | A-1 |
| Battery Disconnect Warning Indicator | A-1 |
| Backward Compatibility | A-1 |
| Upgrading the Main Board | A-2 |
| Removing the old Main Board | A-2 |
| Installing the new Main Board | A-4 |

Warranty

Workmanship & Materials

Criticare Systems, Inc. (CSI) warrants the 506N3 Series monitor to be free from defects in workmanship and materials for a period of one (1) year from date of shipment under normal use and service. The monitor warranty does not include batteries, sensors, probes, cables, cuffs, and hoses. CSI's obligation under this warranty is limited to repairing or replacing, at CSI's option, any part which upon CSI's examination proves defective.

Nellcor accessories carry a 90 day warranty.

EXCEPT AS DESCRIBED IN THE PARAGRAPH ABOVE, CSI MAKES NO WARRANTIES, EXPRESS OR IMPLIED, INCLUDING ANY WARRANTY OF MERCHANTABILITY OR FITNESS FOR A PARTICULAR PURPOSE.

Exemptions

CSI's obligation or liability under this warranty does not include any transportation or other charges or liability for direct, indirect or consequential damages or delay resulting from the improper use or application of the product or the substitution upon it of parts or accessories not approved by CSI or repair by anyone other than a CSI authorized representative.

This warranty shall not extend to any instrument which has been subjected to misuse, negligence or accident; any instrument from which CSI's original serial number tag or product identification markings have been altered or removed; or any product of any other manufacturer.

Safety, Reliability & Performance

Criticare Systems, Inc. is not responsible for the effects on safety, reliability and performance of the 506N3 Series patient monitors if: assembly operations, extensions, readjustments, modifications or repairs are carried out by persons other than those authorized by Criticare Systems, Inc., or

the 506N3 Series monitors are not used in accordance with the instructions for use, or

the electrical installation of the relevant room does not comply with NFPA 70: National Electric Code or NFPA 99: Standard for Health Care Facilities (Outside the United States, the relevant room must comply with all electrical installation regulations mandated by the local and regional bodies of government).

In Case of Emergency Contact



CRITICARE SYSTEMS, INC.
20925 Crossroads Circle
Waukesha, WI 53186
USA

Telephone: (262) 798-8282
Tech Support: (800) 458-2697
Orders: (800) 458-4615
Fax: (262) 798-8290

Internet: www.csiusa.com

Service Return Policy

Return Procedure



In the event that it becomes necessary to return a unit to Criticare Systems, Inc., the following procedure should be followed:

Obtain return authorization. Contact the CSI Service Department at 800-458-2697 to obtain a Customer Service Authorization (CSA) number. (Outside the US, call 001-262-798-8282.) The CSA number must appear on the outside of the shipping container. Return shipments will not be accepted if the CSA number is not clearly visible. Please provide the model number, serial number, and a brief description of the reason for return.

Freight policy. The customer is responsible for freight charges when equipment is shipped to CSI for service (this includes customs charges).

Loaner service. In the U.S. If it is necessary to provide a loaner system, CSI will ship a loaner by overnight courier. The loaner system must be returned to CSI at the customer's expense within one week after receipt of the repaired goods. If the unit is not returned to CSI within that time, the customer will be invoiced for the full purchase price of the equipment.

Outside the U.S. No loaners are available from CSI internationally. Contact your local CSI representative.

Incoming Inspection

The following incoming inspection is required whether it is a first time arrival or a return from service. Prior to clinical use, the instrument should be inspected for the following.

1. The quality inspection seal on the instrument should be unbroken. This seal indicates that the instrument has been tested according to manufacturers specifications.
2. No physical damage is observed.
3. The instrument's battery is to be charged by connecting the instrument to a power outlet for a minimum of 6 hours prior to clinical use.
4. When connecting the instrument to a power outlet and then turning the instrument on, all displays appear to function correctly and no system errors occur.

If a discrepancy to these inspection items is observed, do not use the instrument and immediately report the discrepancy to the CSI Service Department.

EC Declaration of Conformity

506N3 Series Patient Monitors

To view the Declaration of Conformity, visit the Criticare website at www.csiusa.com. Contact Criticare's customer service department at (262) 798-8282 to obtain a faxed copy of the Declaration.

Representative in the European Union

Criticare Systems Limited
c/o Wright Hassall
9 Clarendon Place
Leamington Spa
Warwickshire
CV 32 5QP

T: 0044 (0) 1926 886688
F: 0044 (0) 1926 885588

For the Attention of: Ref. 45 (or) Mr. L. A. Heizler

Section 1 — Introduction

Description

The 506N3 Series patient monitor is a compact vital signs monitor that measures heart rate and non-invasive blood pressure (NIBP). Heart rate measurement is determined primarily by the plethysmographic waveform. For units without the oximeter module, or when the oximeter is not in use, heart rate is determined from the blood pressure data using an oscillometric method that measures during inflation.

Optional configurations include blood oxygen saturation (SpO₂), predictive oral/axillary/rectal temperature and/or an internal printer.

Models are available with a choice of oximeter (DOX or Nellcor OxiMax) and a choice of predictive temperature (FasTemp or TurboTemp). The following models are available.

| | |
|-----------|---|
| 506N3: | NIBP, heart rate |
| 506NP3: | NIBP, printer, heart rate |
| 506DN3: | DOX SpO ₂ , NIBP, heart rate |
| 506DNP3: | DOX SpO ₂ , NIBP, printer, heart rate |
| 506DNT3: | DOX SpO ₂ , NIBP, FasTemp temperature, heart rate |
| 506DNTP3: | DOX SpO ₂ , NIBP, FasTemp temperature, printer, heart rate |
| 506DNV3: | DOX SpO ₂ , NIBP, TurboTemp temperature, heart rate |
| 506DNVP3: | DOX SpO ₂ , NIBP, TurboTemp temperature, printer, heart rate |
| 506LN3: | Nellcor SpO ₂ , NIBP, heart rate |
| 506LNP3: | Nellcor SpO ₂ , NIBP, printer, heart rate |
| 506LNT3: | Nellcor SpO ₂ , NIBP, FasTemp temperature, heart rate |
| 506LNTP3: | Nellcor SpO ₂ , NIBP, FasTemp temperature, printer, heart rate |
| 506LNV3: | Nellcor SpO ₂ , NIBP, TurboTemp temperature, heart rate |
| 506LNVP3: | Nellcor SpO ₂ , NIBP, TurboTemp temperature, printer, heart rate |
| 506NT3: | NIBP, FasTemp temperature, heart rate |
| 506NTP3: | NIBP, FasTemp temperature, printer, heart rate |
| 506NV3: | NIBP, TurboTemp temperature, heart rate |
| 506NVP3: | NIBP, TurboTemp temperature, printer, heart rate |

Intended Use

This equipment is intended for use only by qualified medical providers in conjunction with established medical protocols.

All models in the 506N3 series are designed to monitor physiological parameters of patients, providing the health care provider with physiological data, alarms, and trend records.

The monitor is designed to be used with only one patient at a time.

About this Manual

This manual contains only the information required to service the monitor. For information on operation, monitoring, and setting up the monitor, consult the *506N3 Series Patient Monitor Operator's Manual*.

This manual is designed to help diagnose and service the sub-assemblies of the 506N3 Series monitor.

Parts lists and block diagrams are included to help the technician understand how the monitor systems operate.

Criticare Systems, Inc., does not intend for repair to be performed on the circuit boards by anyone except the Criticare Service Department.

NOTE: The proceeding items in this section address all possible functions and options of the 506N3 Series patient monitor. Depending on the model and features of your unit, some items may not apply.

Non-Invasive Blood Pressure (NIBP)

The 506N3 Series monitor uses ComfortCuff™ technology to determine non-invasive blood pressure by means of oscillometry. The oscillometric method detects volume displacements within the artery and senses pressure variations within the blood pressure cuff during inflation. The monitor uses cuffs ranging in size from neonate cuffs to adult thigh cuffs.

Comfort Cuff Technology

ComfortCuff technology measures NIBP while the cuff inflates. Consequently, a measurement is obtained more quickly and with less discomfort than with monitors which measure NIBP during cuff deflation.

- This device was clinically tested per the requirements of EN 1060 and AAMI SP-10.
- The NIBP monitor generates alarm messages in situations of extremely irregular heart beat or patient motion. The monitor automatically attempts a second measurement in either case.

Description of NIBP Measurement

The NIBP cuff begins to inflate at the beginning of the NIBP measurement cycle. As the cuff pressure approaches the diastolic pressure of the patient, the cuff pressure waveform begins to indicate the pulse waveform. The cuff pressure at this point is equal to the patient's diastolic pressure, which is stored by the monitor.

As cuff pressure continues to increase, the pulse waveform (as measured from BP cuff pressure fluctuation) becomes stronger, reaching its maximum at the patient's mean arterial pressure (i.e., when cuff pressure = mean BP). The monitor stores this value as mean pressure.

As cuff pressure increases further, it approaches the patient's systolic pressure, and the cuffs pulse waveform decreases in amplitude. The cuff pulse waveform disappears at the point where cuff pressure is equal to the patient's systolic pressure.

When the monitor determines that the cuff waveform has decreased to zero amplitude, it stores the cuff pressure value as the systolic pressure, and releases the pressure from the cuff. This typically occurs at about 10 mmHg over the patient's systolic pressure. The cuff then rapidly deflates. Because of the pulsatile nature of the pressure values, the inflation range needs to exceed the systolic and diastolic values. The dynamic measurement ranges are:

Adult: 35 to 280 mmHg
 Pediatric: 35 to 130 mmHg
 Neonate: 25 to 130 mmHg

Cuff Inflation and Pressure Protection

The maximum allowable cuff pressure is 300 mmHg adult mode (150 mmHg in neonate mode). Adult mode cuff pressure is allowed to remain above 15 mmHg for a maximum of 180 seconds. Neonatal mode cuff pressure is allowed to remain above 5 mmHg for a maximum of 90 seconds.

The monitor automatically deflates the cuff if the time limit is violated. The monitor contains hardware protection for overpressure conditions, pressure transducer failures, or microprocessor and pump control circuit failures.

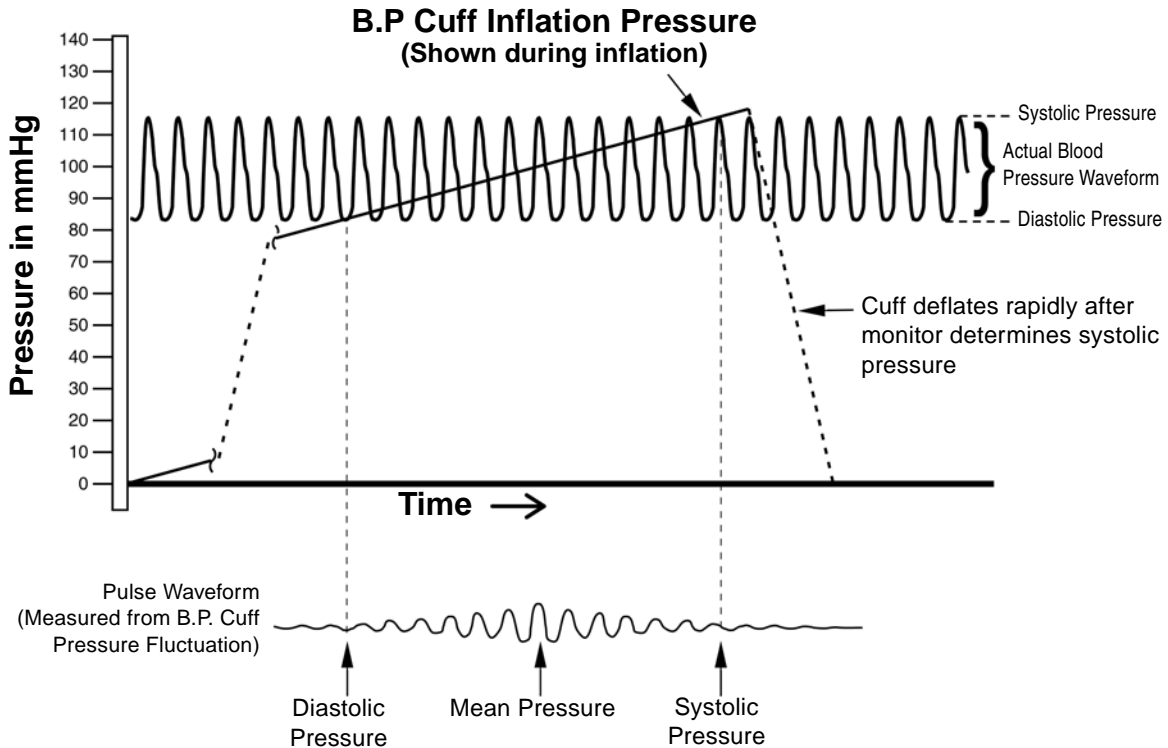

Heart Rate

Heart rate measurement is determined primarily by the plethysmographic (SpO₂) waveform. When the oximeter is not in use, the heart rate is determined from the blood pressure data using an oscillometric method that measures during inflation. The unit of measurement is beats per minute.

Under conditions where the plethysmographic based heart rate and the oscillometric heart rate are both beyond the detectable limits of the monitor, no heart rate is reported. Also, no heart rate is reported where the amplitude of the plethysmographic waveform and oscillometric waveform are beyond the detectable limits. The monitor reports error messages if valid measurements cannot be obtained. The monitor continues to look for valid SpO₂ based heart rate measurements and attempts a second NIBP measurement if the first attempt fails.

DOX™ Pulse Oximetry Measurement (SpO₂)

The 506N3 Series monitor is available with Digital Oximetry (DOX™) technology to measure blood oxygen saturation (SpO₂).

Definition Hemoglobin exists in the blood in several forms:

- Oxygenated (Oxyhemoglobin)
- Reduced (Deoxyhemoglobin)
- Dyshemoglobins (carboxyhemoglobin and methemoglobin.)

In the monitor, SpO₂ (pulse arterial oxygen saturation) is the ratio of oxygenated hemoglobin to the sum of oxygenated hemoglobin plus hemoglobin which is available for binding to oxygen, as expressed in the following formula:

$$\text{percent oxygen saturation} = \frac{\text{oxyhemoglobin}}{\text{oxyhemoglobin} + \text{deoxyhemoglobin}} \times 100$$

Dyshemoglobins, such as carboxyhemoglobin and methemoglobin, are not directly measured and therefore are not factored into the measurement.

DOX Digital Oximetry

The monitor does not use analog circuitry for signal processing. Digital signal processing in the microprocessor results in lower noise from circuitry components, resulting in a cleaner signal and better performance under low perfusion conditions. There is also improved rejection of noise from the patient and environment, due to the availability of the “true,” unfiltered sensor signal for digital signal processing.

Method The digital pulse oximeter measures oxygen saturation and pulse rate using the principles of spectrophotometry and plethysmography. The sensor is completely non-invasive, and there is no heat source that could burn the patient.

The pulse oximeter sensor contains two types of LEDs; each type emits a specific wavelength of light. Since oxygenated hemoglobin and deoxygenated hemoglobin absorb light selectively and predictably, the amounts of these two compounds can be determined by measuring the intensity of each wavelength that passes through the measuring site.

The light from the LEDs shines into a pulsating vascular bed. A photodetector located opposite or alongside the LEDs measures the intensity of each wavelength transmitted through the monitoring site. The light intensity is converted to an electrical signal, which is input to the monitor. The effects of skin pigmentation, venous blood, and other tissue constituents are eliminated by separating out the pulsating absorption data.

SpO₂ is calculated with every pulse and averaged with the results from previous pulses to arrive at the current numeric display value. The display is updated at least once per second with the numeric values that were calculated during the intervening period.

The plethysmographic pulse bar is not auto-gained. The amplitude display of the plethysmographic pulse bar is proportional to the pulse volume changes occurring in the tissue illuminated by the SpO₂ sensor.

SpO₂ Clinical Testing and Accuracy

All Criticare Systems, Inc., oximeters have SpO₂ calibration tables which were originally generated by monitoring desaturated human patients or volunteers and matching their displayed SpO₂ value to the value determined by sampling arterial blood and measuring functional SaO₂ with a clinical laboratory grade multi wavelength optical oximeter (i.e. CO-oximeter). The final SpO₂ calibration curve was then generated based upon numerous patients' data over the range of 40 to 99% SaO₂. All accepted data were taken from patients with dyshemoglobin (i.e., carboxyhemoglobin, methemoglobin) concentrations near zero.

This oximeter is a two-wavelength device, which is calibrated to measure functional SpO₂ only when dyshemoglobin concentrations are near zero. The accuracy specifications of this device will not be met with high concentrations of dyshemoglobins. Significant concentrations of carboxyhemoglobin results in a higher displayed SpO₂ value than is actually present in the patient.

Nellcor Pulse Oximetry Measurement (SpO₂)

The 506N3 Series monitor is also available with Nellcor OxiMax® technology to measure blood oxygen saturation (SpO₂).

Definition The Nellcor OxiMax uses pulse oximetry to measure functional oxygen saturation in the blood. Pulse oximetry works by applying an OxiMax sensor to a pulsating arteriolar vascular bed, such as a finger or toe. The OxiMax sensor contains a dual light source and a photo detector.

Because a measurement of SpO₂ is dependent upon light from the OxiMax sensor, excessive ambient light can interfere with this measurement.

Criticare's implementation of the OxiMax oximeter rounds down SpO₂ saturation values above 99.6% that might normally be reported as 100% oxygen saturation in other implementations.

Method Pulse oximetry is based on two principles: that oxyhemoglobin and deoxyhemoglobin differ in their absorption of red and infrared light (spectrophotometry), and that the volume of arterial blood in tissue (and hence, light absorption by that blood) changes during the pulse (plethysmography). A pulse oximeter determines SpO₂ by passing red and infrared light into an arteriolar bed and measuring changes in light absorption during the pulsatile cycle. Red and infrared low-voltage light-emitting diodes (LED) in the oximetry OxiMax sensor serve as light sources; a photo diode serves as the photo detector.

Because oxyhemoglobin and deoxyhemoglobin differ in light absorption, the amount of red and infrared light absorbed by blood is related to hemoglobin oxygen saturation. To identify the oxygen saturation of arterial hemoglobin, the monitor uses the pulsatile nature of arterial flow. During systole, a new pulse of arterial blood enters the vascular bed, and blood volume and light absorption increase. During diastole, blood volume and light absorption reach their lowest point. The pulse oximeter bases its SpO₂ measurements on the difference between maximum and minimum absorption (measurements at systole and diastole). By doing so, it focuses on light absorption by pulsatile arterial blood, eliminating the effects of nonpulsatile absorbers such as tissue, bone, and venous blood.

The display is updated at least once per second with the numeric values that were calculated during the intervening period.

The plethysmographic pulse bar is not auto-gained. The amplitude display of the plethysmographic pulse bar is proportional to the pulse volume changes occurring in the tissue illuminated by the SpO₂ sensor.

Automatic Calibration During monitoring, the instrument's software selects coefficients that are appropriate for the wavelength of that individual OxiMax sensor's red LED; these coefficients are then used to determine SpO₂.

Additionally, to compensate for differences in tissue thickness, the light intensity of the OxiMax sensor's LEDs is adjusted automatically.

Accuracy of OxiMax Sensors The accuracies of the OxiMax sensors are listed in the following chart:

| | OxiMax Sensor Models | SpO₂ Range 70-100% |
|---------------------------|-----------------------------|--------------------------------------|
| Single Use Sensors | MAX-A, MAX-AL | ± 2 |
| | MAX-N (Adult) | ± 2 |
| | MAX-N (Neonate) | ± 3 |
| | MAX-P | ± 2 |
| | MAX-I | ± 2 |
| | MAX-FAST | ± 2 |
| Reusable Sensors | D-YS (Infant to Adult) | ± 3 |
| | D-YS (Neonate) | ± 4 |
| | D-YS & D-YSE (Neonate) | ± 3.5 |
| | D-YS & D-YSPD | ± 3.5 |
| | DS-100A | ± 3 |
| | OXI-A/N (Adult) | ± 3 |
| | OXI-A/N (Neonate) | ± 4 |
| | OXI-P/I | ± 3 |

Functional versus Fractional Saturation This pulse oximeter measures functional saturation \bar{n} oxygenated hemoglobin expressed as a percentage of the hemoglobin that can transport oxygen. It does not detect significant amounts of dysfunctional hemoglobin, such as carboxyhemoglobin or methemoglobin. In contrast, hemoximeters such as the IL482 report fractional saturation \bar{n} oxygenated hemoglobin expressed as a percentage of all measured hemoglobin, including measured dysfunctional hemoglobins. To compare functional saturation measurements to those from an instrument that measures fractional saturation, fractional measurements must be converted as follows:

$$\text{functional saturation} = \frac{\text{fractional saturation}}{100 - (\% \text{carboxyhemoglobin} + \% \text{methemoglobin})} \times 100$$

Measured versus Calculated Saturation

When saturation is calculated from a blood gas partial pressure of oxygen (PO_2), the calculated value may differ from the SpO_2 measurement of a pulse oximeter. This usually occurs because the calculated saturation was not appropriately corrected for the effects of variables that shift the relationship between PO_2 and pH, temperature, the partial pressure of carbon dioxide (PCO_2), 2,3-DPG, and fetal hemoglobin. See “Figure 1-2: Oxyhemoglobin Dissociation Curve”.

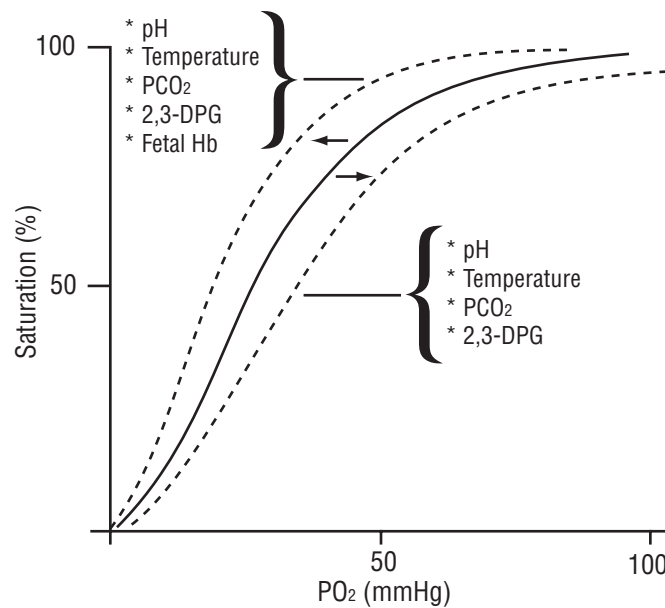

Figure 1-2: Oxyhemoglobin Dissociation Curve

Temperature

The 506N3 Series monitor is available with an optional temperature module utilizing either FILAC® FasTemp® or Alaris™ (IVAC) TurboTemp® technology.

Two modes are available: Predictive and Continuous.

Predictive Mode The default mode is Predictive Mode. This allows the thermometer to predict the end point that the thermistor would reach if it were left in the mouth until it reached mouth temperature. This predictive feature allows the thermometer to arrive at an accurate oral temperature reading within about 10 seconds.

When the probe is withdrawn from the isolation chamber, the probe's tip is preheated for approximately two seconds. During this preheat mode the temperature site LED blinks. An audio beep sounds if the preheat is terminated. Predictive temperature measurement begins and is indicated by the rightmost TEMPERATURE display digit sequencing its segments in a clockwise fashion (pinwheel). When the final predictive temperature is achieved, an audible "high-low" tone sounds and the temperature reading (in degrees and tenths of a degree) appears on the TEMPERATURE display along with either °C or °F in place of the pinwheel to indicate a final stable temperature reading.

FASTEMP MODULE

In the event the FasTemp module is unable to achieve a predictive temperature within thirty seconds, and the sensed temperature is above 30° C, the FasTemp enters the Direct Mode in which the current sensed temperature is displayed. To distinguish this mode the temperature site LED blinks. The monitor continues to search for a stable measurement in the Direct Mode and attempts to arrive at a final stable temperature as described above. The site indicator continues to flash until a stable measurement displays.

Should the sensed temperature be 30° C or lower or higher than 43° C at the end of the thirty second interval, a Low Priority alarm sounds and a *TEMP:INVALID* message appears in the LCD message screen. The TEMPERATURE LEDs show dashes.

TURBOTEMP MODULE

In the event the TurboTemp module is unable to achieve a predictive temperature within one minute the monitor will time out and respond with a message.

Should the sensed temperature be above 106°F (41.1°C) or higher within a thirty second interval, a Low Priority alarm sounds and a *TEMP:INVALID* message appears in the LCD message screen. The TEMPERATURE LEDs show dashes.

Should the sensed temperature be between 80.0 and 94.0°F at the end of the thirty second interval, a Low Priority alarm sounds and a *TEMP:CONTACT* message appears in the LCD message screen. This message implies non-contact with human tissue.

Continuous Mode In Continuous Mode, the thermometer continuously measures the patient's temperature as it rises or falls. This method is not predictive and does not pre-heat the probe prior to attempting a measurement. The temperature displayed is the probe temperature. The probe must be allowed time to attain a stable temperature using the same technique as a mercury thermometer.

After proper probe cover installation and application of the temperature probe in either the oral, axillary, or rectal cavity, the temperature measurement begins. The temperature display shows the current probe temperature readings, along with an F or C. As the patient's temperature rises or falls, the display changes accordingly. All temperature site LEDs are turned off in Continuous Mode. All displayed measurements are considered to be unstable.

Axillary Measurements The *TurboTemp* thermometer measures axillary (arm pit) temperature using the continuous operating mode. The temperature site LED will flash indicating that the displayed temperature must be observed over time to determine a stable measurement.

Clinical Testing and Accuracy Predictive thermometry measures temperature at discrete intervals and then calculates the rate of change according to a proven algorithm.

The *FILAC FasTemp* electronic thermometer in its predictive mode has been tested to comply with EN 12470-3 and ASTM E1112:98. The *FILAC FasTemp* meets these standards in predictive mode to provide highly accurate predictive measurements. When patient fevers (at or above 37.6 °C/99.7 °F) are encountered by *FILAC FasTemp*, measurement time may exceed 20 seconds in order to achieve the accuracy necessary for those conditions.

The *Alaris TurboTemp* electronic thermometer has been tested to the accuracy of ± 0.1 °C (± 0.2 °F) in the continuous operation mode using a calibrated water bath. The accuracy range of 98.0 °F to 102.0 °F meets the range specified in ASTM specification #1112, Table 1.

Specifications

DOX SpO₂

| | |
|---------------------------------------|---|
| Accuracy: | 70 to 100: $\pm 2\%$ 50 to 69: $\pm 3\%$ 0 to 49: Unspecified Statistical, represents one st. dev. (~66%) of clinical samples |
| Range: | 1-99% |
| Resolution: | 1% |
| Indications | Numerical, Audible (pulse tone pitch varies with SpO ₂) |
| Method: | Dual wavelength LED |
| Operation: | Continuous Use |
| Sensor Wavelength: | 660nm/905nm |
| Sensor Power: | <80mW |
| SpO ₂ Pulse Rate Range: | 20 to 300 |
| SpO ₂ Pulse Rate Accuracy: | ± 1 bpm |

Nellcor SpO₂ (OxiMax)

| | |
|---------------------------------------|---|
| Accuracy: | 70 to 100: $\pm 2\%$ Below 69: Unspecified Neonate: 70 to 100: $\pm 3\%$ Statistical, represents one st. dev. (~66%) of clinical samples (Sensor accuracy is found in "Accuracy of OxiMax Sensors" on page 1-8) |
| Range: | 1-99% |
| Resolution: | 1% |
| Indications | Numerical, Audible (pulse tone pitch varies with SpO ₂) |
| Method: | Dual wavelength LED |
| Operation: | Continuous Use |
| Motion Artifact Rejection: | yes |
| SpO ₂ Pulse Rate Range: | 20 to 300 bpm |
| SpO ₂ Pulse Rate Accuracy: | ± 2 bpm (20 to 250 bpm) |

ComfortCuff NIBP

| | |
|-------------------------------|---|
| Technique: | Oscillometric measure upon inflation |
| Average Measurement Time: | <30 sec. |
| Automatic Measurement Cycles: | 1, 2, 3, 5, 10, 15, 30, 45, 60 min.; 2, 4 hrs |
| Inflation Pressure Range: | Adult: 30 to 300 mmHg Pediatric: 30 to 150 mmHg Neonate: 20 to 150 mmHg |
| Max Inflation: | Adult: 300 Pediatric, Neonate: 150 |
| NIBP Pulse Rate Range: | 30 to 240 |
| Resolution: | 1 mmHg |
| NIBP Pulse Rate Accuracy: | ±1 bpm or 1% |
| STAT mode: | 5 min. of consecutive readings |
| Clinical Accuracy: | SP10:2002 |
| Clinical Mean Error: | Less than ±5 mmHg |
| Clinical Standard Deviation: | Less than ±6.93 mmHg |
| Static Transducer Accuracy: | ±2 mmHg |

Temperature (FasTemp)

| | |
|-----------------------------|---|
| Measurement Range: | 30.0° C to 43.0° C (85.0° F to 110.0° F) |
| Response Time Oral: | 4 to 10 sec. typical |
| Response Time Axial/Rectal: | 10 sec. typical |
| Continuous Mode Accuracy: | ±0.1° C, ±0.2° F full range |
| Predictive Mode Accuracy: | For ambient temperatures 18.0° C to 28.0° C: ±0.1° C (35.5° C to 42.0° C) For full range ambient temperatures 10.0° C to 40.0° C, 50.0° F to 104.0° F: ±0.2° C (30.0° C to 36.9° C) ±0.1° C (37.0° C to 39.0° C) ±0.2° C (39.1° C to 43.0° C) ±0.5° F (85.0° F to 96.3° F) ±0.3° F (96.4° F to 97.9° F) ±0.2° F (98.0° F to 102.0° F) ±0.3° F (102.1° F to 106.0° F) ±0.5° F (106.1° F to 110.0° F) |
| Display Resolution: | ±0.1° C (±0.1° F) |
| Compliance Standards: | EN 12470-3:1998, ASTM E1112 |

Temperature (TurboTemp)

| | |
|-------------------------------|--|
| Predictive Measurement Range: | 35.6° C to 41.0° C (96.0° F to 106.0° F) |
| Continuous Measurement Range: | 26.0° C to 41.1° C (80.0° F to 106.0° F) |
| Response Time: | 10 sec. typical (oral measurements) |
| Continuous Mode Accuracy: | ±0.1° C, ±0.2° F full range |
| Display Resolution: | ±0.1° C (±0.1° F) |

Heart Rate

| | |
|-----------------|--|
| Source: | Plethysmograph or oscillometric NIBP data |
| Accuracy Range: | 30 to 240 (for all parameters) |
| Accuracy: | 506LN3 Series: ± 2 bpm or 1% (for all parameters) 506DN3 Series: ± 1 bpm or 1% (for all parameters) |

Alarms

| | |
|------------------|----------------------------------|
| Characteristics: | EN 475, Adjustable |
| Indication: | Audible; Visual |
| Levels: | High, Medium, Low, Informational |
| Alarm Modes: | Adult, Pediatric, Neonate |
| Volume: | User Adjustable |
| Silence: | Yes; 2 minutes or permanent |

Communications

| | |
|-----------|-------------------------------|
| Com Port: | Serial; DB-9 serial connector |
|-----------|-------------------------------|

Display & Controls

| | |
|--------------------|---|
| Display: | LCD Text, LED |
| Status Indicators: | Alarm Silence, Battery Status, Sensor, AC Power, Patient Size, Temperature Source |
| Keys: | Up to 11; membrane-activated |
| Languages: | English, French, German, Italian, Portuguese, Spanish, Danish, Dutch |

Trend Reports & Memory

| | |
|-------------------------|--|
| Types: | Tabular Trend Reports (User configurable by interval and parameters, multi parameter trend reports) |
| Trend Report Length: | 24 hours max; selectable intervals |
| Review Mode: | On-panel review of trend reports |
| Interval (Review Mode): | SpO ₂ recorded every minute, every valid NIBP measurement and predictive temperature measurement recorded |
| Data Types: | NIBP (Systolic, Diastolic, Mean), Heart Rate, SpO ₂ Percent, Temperature |

Printer

| | |
|-------------------------|---|
| Recorder Type: | Internal thermal printer |
| Data Formats: | Tabular |
| Interval Print: | 1, 2, 5, 10, 15, 30, 60 minutes; 2, 4, 8, 12, 24 hours |
| Data Types: | NIBP, SpO ₂ , Pulse, Temperature |
| Selectable Print Types: | Print on NIBP and/or alarm |

Mechanical/Electrical

















| | |
|-----------------------------|--|
| Weight: | 3.0 kg; 6.7 lbs. (base unit with battery) |
| Size (without temperature): | 22 cm (H) x 18 cm (W) x 16.5 cm (D) 8.7 in. (H) x 7.1 in. (W) x 6.5 in. (D) |
| Size (with temperature): | 22 cm (H) x 22 cm (W) x 16.5 cm (D) 8.7 in. (H) x 8.7 in. (W) x 6.5 in. (D) |
| Battery: | Rechargeable; Sealed lead acid battery |
| Rating: | 6V, 7.2 Amp Hours |
| Battery Life: | 8 hours, with NIBP every 5 minutes |
| Recharge Time: | 6 hours |
| Power Requirements: | 100 – 240 VAC ($\pm 10\%$), 50 – 60 Hz |



Environmental

| | |
|---------------------------------|-----------------------------------|
| Operating Temperature: | 0° to 45° C (32° to 113°F) |
| Storage Temperature: | -5° to 50°C (23° to 122°F) |
| Operating and Storage Humidity: | 15% to 90%; non-condensing |
| Medical Device: | Class II Equipment |
| Electrical Protection: | Class I Equipment |
| Degree of Protection: | Type CF, Defibrillator-Proof |
| Protection against ingress: | IPX1 rating, Drip-Proof Equipment |

All specifications are subject to change without notice.

Symbols

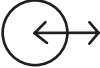
| Symbol | Definition |
|---|---|
|  | Refer to Operator's Manual for Information |
|  | Shock Hazard |
|  | Not For Use with Flammable Anesthetic Gasses |
|  | European Community Mark of Approval |
|  | Electrical Testing Laboratories (ETL) Mark |
| IPX1 | Identifies the degree of protection against fluid as drip-proof |
|  | Type CF Equipment, defib proof |
|  | Do not dispose of in municipal waste. Wheeled bin symbol indicates separate collection for electrical and electronic equipment. (WEEE Directive 2002/96/EEC) |
|  | Alternating Current (AC) |
|  | Fuse |
|  | Technical Support Phone Number |
|  | Non-Invasive Blood Pressure, Connection |
|  | Systolic blood pressure |
|  | Mean blood pressure |
|  | Diastolic blood pressure |
|  | Temperature Monitoring |
|  | SpO ₂ Sensor Monitoring, Connection |
|  | Heart Rate |

| Symbol | Definition |
|---|-------------------------------------|
|  | Communication Transmit/Receive Port |
|  | Not a Sensor Connection |

Safety

Definitions for Warning and Caution symbols:



Designates a possible dangerous situation. Non-observance may lead to death or the most severe injuries.



Designates a possible dangerous situation. Non-observance may lead to minor injuries or damage to the product.

NOTE: Indicates that important information follows, a tip that can help you recover from an error, or point you to related details in the manual.

WARNING

- Read this manual entirely before attempting clinical use of the monitor.
- A possible explosion hazard exists! Do not use the monitor in the presence of flammable anesthetics.
- Cables, cords, and leadwires may present a risk of entanglement or strangulation! Verify safe and proper positioning of these items after patient application.
- Unapproved modifications to the monitor may cause unexpected results and present a hazard to the patient.
- Risk of electrical shock! Do not remove cover. Refer servicing to qualified personnel.
- U.S. Federal law restricts this device to sale by or on the order of a physician.



CAUTION

- Use the monitor only with recommended accessories! Use of unapproved accessories may cause inaccurate readings.
- Equipment accuracy may be affected at extreme temperatures.
- Do not store equipment at extreme temperature. Temperatures exceeding specified storage temperatures could damage the system.
- Do not press on the keys with surgical instruments or other tools. Sharp or hard objects could damage the keys. Use only your fingertips to press on the keys.
- Changes or modifications not expressly approved by Criticare Systems, Inc., may void the user's authority to operate the equipment and may also void the warranty.

| | |
|---|---|
| Software Error Related Hazard Mediation | <p>Criticare Systems, Inc., has quality control practices and procedures in place to review potential hazards as they relate to software.</p> <p>The monitor is Year 2000 Compliant and utilizes a 4 digit year for all date, time, and leap year calculations.</p> |
| Potential Interference | <p>This device has been successfully tested to IEC 60101-1-2 specified levels for emissions of and resistance to electromagnetic energy fields. External disturbances which exceed these levels may cause operational issues with this device. Other devices which are sensitive to a lower level of emissions than those allowed by IEC 60101-1-2 may experience operational issues when used in proximity to this device.</p> <p>MAGNETIC FIELDS Use of the monitor in an MRI environment may interfere with MRI image quality. Use of MRI may interfere with the monitor.</p> <p>RADIO FREQUENCY INTERFERENCE The monitor conforms with IEC 1000-4-3 for radio frequency interference, and will operate with negligible adverse effects.</p> <p>CONDUCTED TRANSIENTS The monitor conforms with IEC 61000-4-4, and IEC 61000-4-5 for conducted transients, and will operate with negligible adverse effects.</p> <p>X-RAY The monitor will operate with negligible adverse effects in an x-ray environment. However, the monitor should not be placed directly in the x-ray beam, which could damage the internal electronics of the monitor.</p> <p>OTHER INTERFERENCE There is a negligible adverse effect to the monitor from electrocautery, electrosurgery, infrared energy, pacemakers, or defibrillation.</p> |
| Leakage Current | <p>The monitor complies with leakage current limits required by medical safety standards for patient-connected devices. Standards include the International Electrotechnical Commission (IEC) 60101-1, 1st edition, 2003 Part 1. A hazard caused by the summation of leakage currents is possible, when several pieces of equipment are interconnected.</p> |

| | |
|---|--|
| Voltage Fluctuations | The monitor is suitable for connection to AC (mains) voltage as defined by EN61000-3-3 and EN61000-4-11. When operated in the line voltage range specified in this manual any fluctuation will have a negligible effect. Very low line voltage will cause the monitor to revert to battery power. Very high line voltage may cause damage to the charger circuits. The monitor is designed with circuitry that will turn the unit off before spurious readings can be caused by a low battery condition. |
| Defibrillation, HF, and Electronic Device Protection | The monitor when used with its recommended accessories is protected against the effects of the discharge of a defibrillator and the use of HF electrosurgical equipment. The monitor presents no known adverse effects to pacemakers or other medical safety equipment. |
| Biocompatibility | All patient-contact or user-contact materials in this monitor and its accessories have passed ISO 10993-5, -10, & -11 biocompatibility tests or have been in use in clinical environments in large numbers over an extended period of time predating these standards. |
| Latex Content | All Criticare Systems, Inc., products, including patient monitors and accessories, are free from latex in any location that may result in patient contact. |
| DEHP Content | All Criticare Systems, Inc., products currently shipping are free of DBP and DEHP in any areas that would be intended for patient contact with blood, mucous membranes, or continuous skin/tissue contact. |

Section 2 — Service Menus

Introduction

There is one primary service boot that uses the DOWN arrow at power up takes the monitor into Service Mode. A secondary service boot uses the NIBP START/STAT/STOP key at power up and takes the monitor into *NIBP Calibration Mode*. These service software tools allow downloading of software upgrades for the 506N3 Series operating system and for calibration of the NIBP module in the field.

To exit the *SERVICE DISPLAY* power cycle the 506N3 Series monitor.

Service Mode

WARNING

- Never service a monitor while it is attached to a patient.
- Never enter the service menu while monitoring a patient.

Service Menus The built-in *SERVICE DISPLAY* is displayed if the DOWN ARROW button is held on power up and no upgrade tool is attached to the external serial port.

- The *SERVICE DISPLAY* reports detailed information about the serial number and software revision of the specific monitor.
- The *SERVICE DISPLAY* contains special facility-specified configurations not intended for general users.
- The *SERVICE DISPLAY* has available a series of tests to be selected and executed by the user. Push the MENU key to start the test that appears in the LCD message bar. To skip to the next test push the DOWN ARROW key to go to the next test.

When the service tests are complete, the message *END OF TESTS* appears in the LCD message bar.

Primary Service Displays To access the Service Display, press the DOWN arrow key while pressing the POWER key. The LCD display should read *SERVICE DISPLAY*.

After the greeting screens clear, the primary service menus are accessible by using the UP/DOWN ARROW keys to scroll through each primary menu item. Each primary service menu shall have at least one secondary service menu.

The primary service menus are:

- *REVISIONS*
- *BOARD SETUPS*
- *DEFAULT SETUPS*
- *TEST MENU*

Secondary Service Displays Pressing the MENU key once within a primary service menu item accesses the secondary service menu item(s).

With the exception of the *REVISIONS* service item, an arrow (<-->) points at the secondary service menu item to designate that the user is in this mode. Press UP and DOWN arrow keys to scroll through secondary service menu items.

Press the MENU key to choose the desired secondary service menu. This toggles the arrow to point the other way {-->} and moves to the value selection.

Hold the MENU key to return to the primary service menu item.

Service Display List The following is a list of service primary and secondary menu items follows and each default and description/values.

| Primary Menu | Secondary Menu | Default | Description |
|---------------|-------------------------------------|---|--|
| REVISIONS | 506N3_SERIES | N/A | Model series |
| | Revision <i>nn.nn</i> | N/A | Main software revision <i>nn.nn</i> is alphanumeric revision identifier – decimal point may vary |
| | MMM DD YYYY | N/A | Main software revision date |
| | S/N: <i>nnnnnnnn</i> | N/A | Monitor serial number |
| | APP. CS. : <i>nnnn</i> | N/A | Main software checksum |
| | SpO ₂ XXXXX <i>nn.nn</i> | N/A | SpO ₂ module revision where XXXXX is a three to five character name for the type of SpO ₂ module; <i>nn.nn</i> is alphanumeric revision identifier – decimal point may vary. |
| | SpO ₂ NOT SENT | N/A | SpO ₂ module did not send software revision information. This message displays if no module is present. |
| | NIBP XXXXX <i>nn.nn</i> | N/A | NIBP module revision where XXXXX is a three to five character name for the type of NIBP module; <i>nn.nn</i> is alphanumeric revision identifier – decimal point may vary. |
| | NIBP NOT SENT | N/A | NIBP module did not send software revision information. This message displays if no module is present. |
| | TEMP XXXXX <i>nn.nn</i> | N/A | Temperature module revision where XXXXX is a three to five character name of the type of temperature module; <i>nn.nn</i> is alphanumeric revision identifier – decimal point may vary. |
| TEMP NOT SENT | N/A | Temperature module did not send software revision information. This message displays if no module is present. | |

NOTE: When entering Revisions, if accessed to quickly some revisions may not show. Wait 5-10 seconds before entering to allow the processor to acknowledge the revisions. If a revision does not show, either that module is not present in the device or the processor is not functioning correctly.

| Primary Menu | Secondary Menu | Default | Description |
|-------------------|------------------|---------|--|
| BOARD SETUPS | SpO ₂ | NONE | Selects which type of SpO ₂ module is installed in monitor. Choices are <i>NONE</i> , <i>DOX</i> (Criticare Digital Oximetry), and <i>NCOR</i> (Nellcor) |
| | NIBP | 1020 | Selects which type of NIBP module is installed in monitor. Choices are <i>NONE</i> and <i>1020</i> . |
| | TEMP | NONE | Selects which type of Temperature module is installed in monitor. Choices are <i>NONE</i> , <i>FSTMP</i> (FasTemp) and <i>Turbo</i> (TurboTemp). |
| DEFAULT SETUPS | CONFIG USER | USER | Selects which type of configuration defaults are restored when the MENU key is held on power up. Choices are <i>USER</i> , <i>HOSP.</i> (hospital), <i>ALT C.</i> (alternate care). |
| | STORE USER | NO | <ul style="list-style-type: none"> Allows the storing of current configuration settings as USER DEFAULTS. Choices are <i>NO</i> and <i>YES</i>. Pressing the MENU key with <i>YES</i> displayed causes this line in the LCD to be replaced by <i>CONFIRM</i> with the choices of <i>NO</i> and <i>YES</i>. Pressing the MENU key with <i>YES</i> displayed shall store to memory. <i>DONE</i> replaces <i>YES</i> in the selection upon completion. |
| | AUDIO OFF | YES | <p>Selects the nature of Alarm Volume setting of <i>OFF</i> in the <i>MAIN MENU</i>, <i>ALARMS</i> configuration.</p> <ul style="list-style-type: none"> <i>YES</i> indicates true silencing of the audio alarm. <i>NO</i> causes the audio to not annunciate alarms but sounds a double beep every two minutes for verification that the audio circuit still functions. |
| | LINE FREQ | 60 | The monitor has a 60 Hz frequency setting for domestic U.S. use and a 50 Hz setting for international use. The frequency must be set correctly to the local AC (Mains) power frequency for the monitor to function correctly. Contact your distributor for more information about which setting to use. |
| TEST MENU | LED TEST | OFF | Tests all segments of the numeric LED display and the single LEDs. Choices are <i>OFF</i> and <i>ON</i> . Press the MENU key with <i>ON</i> displayed to begin the test. This test cannot be canceled once started. The message <i>DONE</i> replaces <i>ON</i> in the selection when the test is completed. |
| | PRINT TEST | OFF | Tests the internal printer by printing all printable characters on the printer paper. Choices are <i>OFF</i> and <i>ON</i> . Press the MENU key with <i>ON</i> displayed to begin the test. The message <i>DONE</i> replaces <i>ON</i> in the selection when the test is completed. |
| | NIBP SEAL | OFF | Tests NIBP pressure seals and transducer. Choices are <i>OFF</i> and <i>ON</i> . Press the MENU key with <i>ON</i> displayed to begin the test sequence with a new prompt message. |

Self Tests **NIBP SEAL**

To perform the NIBP Seal test:

1. Press the UP/DOWN arrow keys to scroll to TEST MENU.
2. Press the MENU key to select TEST MENU.
3. Press the UP/DOWN arrow keys to scroll to NIBP SEAL.
4. Press the MENU key to shift the display arrow to point to the right.
5. Press the UP/DOWN arrow keys to select ON. Press the MENU key. The test window shall appear:

*“START” TO SEAL
XXXX.X mmHg*

The valves close so that the pneumatic circuit can be checked for leaks. This provides a simple field test for verifying the safety and static pressure accuracy of the NIBP transducer.

The current pressure is displayed on the second LCD line with an accuracy of $\pm 2\%$ for all pressures from 0 to 300mmHg. The format allows for the display of negative numbers that indicate negative zero offsets.

Press the MENU key a second time to terminate the test.

LED TEST

Press the MENU key to begin the test. The LED test exercises all numeric and point LED's (except for the POWER LED). This provides a simple field test for verifying the safety of the LED display. Upon test completion, the message *DONE* displays in the bottom line of the LCD.

Press an ARROW key with *DONE* displayed to scroll to the next or previous secondary service menu item.

Press the MENU key with *DONE* displayed to re-enter the *LED TEST*. Press an ARROW key to replace the message *DONE* to *OFF* to prevent accidental restarting of the *LED TEST*.

PRINT TEST

The *PRINT TEST* tests the internal printer by printing all printable characters on the printer paper. The Criticare banner should print first, followed by *PRINTER TEST*:

CSI 506N3 SERIES REV XX.XX
TEST PRINT

Upon test completion, the message *DONE* displays in the bottom line of the LCD.

Press an *ARROW* key with *DONE* displayed to scroll to the next or previous secondary service menu item.

Press the *MENU* key with *DONE* displayed to re-enter the *PRINT TEST*. Press an *ARROW* key to replace the message *DONE* to *OFF* to prevent accidental restarting of the *PRINT TEST*.

NOTE: Monitors built prior to 2007 have an additional alternate print test built in to the firmware which is no longer applicable.

NIBP Calibration Mode

To enter the NIBP Calibration mode:

1. Press the POWER key and the NIBP/START/STAT/STOP key at the same time.
2. The 506N3 Series monitor attempts to connect to extended NIBP calibration tools through the external serial port, identifying itself as a 506N3 Series monitor.
3. The message *CHECKING FOR NIBP TOOLS...* should appear in the LCD message bar.

A service calibration application, called NIBP SERVICE (pn 97083A003), may be run on a connected PC. See “NIBP Calibration” in Section 6 for testing details.

LCD Text Display

This LCD window is a two-line textual display for alarms, messages, menu items, and settings. The LCD display backlight automatically turns on whenever you access the menu or the system displays an alarm or a message. In the absence of alarm or message, the LCD returns to home state. The bottom line will display “New Patient” and the top line will be either blank or show the time of day (Rev 1.2E Main Software and later).

Using the Menu To access the *MAIN MENU* press the MENU key. This displays the main menu and the first main menu choice.

The menu choices appear in the second line as you press the DOWN ARROW key. They appear in the reverse order when you press the UP ARROW key.

The monitor has four main menu headings. Each of these headers has its own submenu:

ALARM MENU
PARAMETER SETUP
PRINTER SETUP
CONFIGURATION

Press the UP ARROW or DOWN ARROW key to scroll through these four options. Press the MENU key to access the desired menu when it displays.

- To access a menu setting, press the MENU key a second time when the desired heading is visible. The header moves to the top text line. Specific settings for each header appear underneath as a submenu.
- To view or find a current setting scroll through the appropriate submenu using the UP/DOWN ARROW keys. The settings appear below the header. Each setting has a name, an arrow, and the current value listed.
- To change the current setting, press the MENU key again to choose the setting. This changes the left arrow to a right arrow, allowing you to change the item. Use the UP/DOWN ARROW keys to select the desired setting value. Press the MENU key to change the selected value to the current setting. The arrow changes back to a left arrow.

Exit the Menu To exit a menu, press and hold the MENU key. The monitor beeps once when you press the key and double-beeps when you hold the key. The LCD text window returns to reporting messages or goes blank if no messages exist.

If there has been no keypad activity for 20 seconds the menu clears. The LCD text window returns to reporting messages or goes blank if no messages exist.

Factory Defaults

To recall factory defaults from memory, hold the MENU key while you press the POWER key to turn on the monitor. Settings affect the *ALARMS*, *PARAMETERS*, *PRINTER SETUP*, *CONFIGURATION*, and the *NIBP CYCLE* Menus.

NOTE: Alarms Menu, Parameter Setup, Printer Setup, and Configurations Menu are all accessed through the *Menu* key on the front panel. The NIBP Cycle Menu, Trend Menu and Patient Type are entered through individual keys on the front panel.

Alarm Menu

| Alarm | Type | Range | Adult | Pediatric | Neonate |
|------------------|------|-----------------------------------|---------------------|---------------------|---------------------|
| Alarm Volume | | 1 to 10, Off | 4 | 4 | 4 |
| Pulse Volume | | 1-10, Off | Off | Off | Off |
| Pulse Rate | High | 80 to 250, Off | 150 | 150 | 180 |
| Pulse Rate | Low | 20 to 150, Off | 40 | 40 | 90 |
| SpO ₂ | High | 70 to 98, Off | Off | Off | Off |
| SpO ₂ | Low | 1 to 98, Off | 90 ‡ | 90 ‡ | 90 ‡ |
| NIBP Systolic | High | 75 to 240, Off | 200 | 200 | 140 |
| NIBP Systolic | Low | 50 to 150, Off | 50 | 50 | 50 |
| NIBP Diastolic | High | 50 to 180, Off | 100 | 100 | 80 |
| NIBP Diastolic | Low | 15 to 50, Off | 30(40) | 30(40) | 30(30) |
| NIBP Mean | High | 70 to 200, Off | 150(Off) | 150(Off) | 100(Off) |
| NIBP Mean | Low | 25 to 125, Off | 50(Off) | 50(Off) | 40(Off) |
| Temperature | High | 31 to 40.6 °C 87.8 to 105.0 °F | 37.8 °C 100.0 °F | 37.8 °C 100.0 °F | 37.8 °C 100.0 °F |
| Temperature | Low | 31 to 40.6 °C 87.8 to 105.0 °F | 33.9 °C 93.0 °F | 33.9 °C 93.0 °F | 33.9 °C 93.0 °F |

‡ The monitor returns a minimum low value of 90 on power up.

() Alternative Care settings.

Parameter Setup

| Parameter | Options | Factory Default Value |
|--------------------------|---|-----------------------------------|
| NIBP Tone | Begin, End, None, *Both | None |
| SpO ₂ Search | 10, 20, 30, 40 | 20 (DN3 Series) |
| SpO ₂ Average | DN3 Series: 3, 6, 9, 12, 15, 18, 21 LN3 Series: F, N | 12 (DN3 Series) N (LN3 Series) |
| Temperature Mode | Pred, Cont | Pred † |
| Degrees F/C | F/C | F |

† The monitor returns to this setting on power up.

* Not available prior to Revision 1.5A Main Software.

Printer Setup

| Setting | Options | Factory Default Value |
|----------------|---|--|
| Print on NIBP | On, Off | On |
| Print on alarm | On, Off | Off |
| Interval | 10, 20, 30 seconds; 1, 2, 5, 10, 15, 30, 60 minutes; 2, 4, 8, 12, 15, 24 hours; Off | Off |
| Output | Printer, Serial, Off | Printer (with internal printer) Serial (without internal printer) |
| Serial | Text, CSV, CUSP, Off | Text |
| Baud Rate | 2400, 4800, 9600, 19200, 38400 | 19200 |

Configuration Menu

| Setting | Options | Factory Default Value |
|------------------|---|-----------------------|
| Date | MM-DD-YYYY, DD-MM-YYYY | MM-DD-YYYY |
| Time | 24-Hour, AM/PM | 24-Hour(AM/PM) |
| Hour | 0 - 23 | N/A |
| Minute | 1-59 | N/A |
| Day | 1-31 | N/A |
| Month | JAN through DEC | N/A |
| Year | 00 - 99 | N/A |
| Contrast | 5-95% | 50% |
| Enable MAP | On/Off | On(Off) |
| NIBP | On/Off | On † |
| SpO ₂ | On/Off | On † |
| TEMP | On/Off | On † |
| Line Frequency*+ | 50 Hz, 60 Hz | 60 Hz |
| Language* | English, French, German, Spanish, Italian, Portuguese, Danish, Dutch | N/A |
| Size | Last, Adult, Pediatric, Neonate | Last |

† The monitor returns to this setting on power up.

N/A This setting does not have a factory default value.

() Alternative Care Settings

* The setting is only available after a MENU power up.

+ Prior to Revision 1.2E Main Software. After 1.2E, line frequency is set in "Service Mode."

NIBP Cycle Menu

| Setting | Options | Factory Default Value |
|------------|--|-----------------------|
| NIBP Cycle | 1, 2, 3, 5 10, 15, 30, 45, 60 minutes; 2 or 4 hours; Off | Off |

NOTE: The *NIBP CYCLE* menu is accessed using the NIBP CYCLE key located on the front panel. All other default settings are accessed using the MENU key with the UP/DOWN keys.

Trend Menu

| Setting | Options | Factory Default Value |
|--------------|---|-----------------------|
| Trend Int. | 1, 2, 5, 10, 15, 30, 60 minutes, Off | 15 minutes |
| Trend Format | BPT, BP, Last, No BPT, All | BPT |
| Trend Span | 10, 15, 30, 60 minutes 2, 4, 8, 12, 24 hours, All | 4 hours |

NOTE: The *Trend* menu is accessed by pressing the TREND key located on the front panel.

Patient Menu

| Setting | Options | Factory Default Value |
|---------|----------------------------|-----------------------|
| Mode | Adult, Pediatric, Neonatal | Adult |

User Defaults

This is a default setting profile that can be set for a facility's special needs. The settings are located in a protected menu to inhibit unauthorized changes to the *USER* defaults settings. The user defaults are initially set to the same settings as the *HOSP* (hospital) defaults. User defaults setup should be performed by qualified personnel.

Setting User Defaults

A facility can save settings in a *USER* default setting. Once the settings are made, the settings can be saved under a *USER* setting profile on the monitor.

To set settings different from the *HOSP* (hospital) defaults:

1. Power up the monitor. Wait for the screen to display *PATIENT*.
2. Press the *PATIENT* key to set the settings for each patient size.
3. Press the *MENU* key.
4. Adjust the settings in *ALARM MENU*, *PARAMETER SETUP*, and *CONFIGURATION* for each patient size.

NOTE: It is not possible to store *USER* defaults for *LOW SPO2 <85%*, *NIBP ON/OFF*, *SPO2 ON/OFF*, *TEMP ON/OFF*, *TEMP MODE*, and *LANGUAGE*. Each of the ignored user defaults is controlled independently of the *USER* default settings. *LOW SPO2* returns to a default value of 85% if the current setting is below 85%.

5. Verify all settings are set correctly.

Power up in Service Mode The monitor needs to be powered up in the Service mode. To power up the monitor in Service mode:

1. Power off the monitor.
2. While holding the DOWN arrow key, press the ON/OFF (Power) key.
3. Continue holding the DOWN arrow key until *SERVICE DISPLAY* appears in the top line of the LCD display.

**SERVICE DISPLAY
REVISIONS**

Figure 2-1: *SERVICE DISPLAY* Message

BOARD SETUPS

1. Press the DOWN arrow key until *BOARD SETUPS* appears in the second line of the LCD display.

**SERVICE DISPLAY
BOARD SETUPS**

Figure 2-2: *BOARD SETUPS* Menu

2. Press the MENU key to enter the *BOARD SETUPS* menu.
3. Verify that the board setups are correct for this monitor.

| Board | Configuration | Setting |
|-------|------------------|---------|
| SpO2 | CSI DOX | DOX |
| | Nellcor | NCOR |
| | No SpO2 | NONE |
| NIBP | CSI Comfort Cuff | 1020 |
| | No NIBP | NONE |
| TEMP | FasTemp | FSTMP |
| | TurboTemp | TURBO |
| | No Temperature | NONE |

4. Press and hold the MENU key to exit the *BOARD SETUPS* menu.

Saving Unit Defaults CONFIGURATION DEFAULTS

1. Press the DOWN arrow key until *DEFAULT SETUPS* appears in the second line of the LCD display.
2. Press the MENU key to access the *DEFAULT SETUPS* menu.
3. Press the DOWN arrow key until *CONFIG DEF* (configure defaults) option appears in the second line of the LCD display.
4. Press the MENU key to change the default. The arrow in that display line should point to the right.
5. Press the UP or DOWN arrow keys until *USer* appears.

6. Press the MENU key. The arrow in that display line should point to the left.
7. Scroll DOWN to *STORE USER*.
8. Press the MENU key. The arrow in that display line should point to the right.
9. Press the UP or DOWN arrow keys until *YES* appears.
10. The monitor asks to CONFIRM. Press the UP or DOWN arrow key until *YES* appears.
11. Press the MENU key. The message *STORE USER<-DONE* should appear.
12. Press and hold the MENU key to exit the *DEFAULT SETUPS* menu.
13. Power cycle monitor to exit Service mode.

NOTE: The following is a list of possible menus and submenus. Depending on the model and configuration of your monitor, some submenus listed may not be applicable.

Alarm Menu

Press the MENU key to enter menus. Press the UP/DOWN keys until the *ALARM MENU* displays. Press the MENU key to enter the *ALARM MENU*.

Press the UP/DOWN keys to move through the alarm submenu until the desired item setting displays in the LCD window.

Press the MENU key to select that item, then use the UP/DOWN keys to scroll through the setting options for that item. When the desired setting displays on the LCD, press the MENU key to select that setting.

Alarm limits are set separately for adult, pediatric, and neonatal modes and are saved independently.

To set adult alarm limits, enter the *ALARM MENU* while you are in the adult mode. Change the patient mode by pressing the PATIENT key until the ADULT LED is lit. Confirm that the ADULT indicator on the front panel is lit. Set all desired alarm limits for adult monitoring conditions.

To set pediatric alarm limits, enter the *ALARM MENU* while you are in the pediatric mode. Change the patient mode by pressing the PATIENT key until the PEDIATRIC LED is lit. Confirm that the PEDIATRIC indicator on the front panel is lit. Set all desired alarm limits for pediatric monitoring conditions.

To set neonate alarm limits, enter the *ALARM MENU* while you are in the neonate mode. Change the patient mode by pressing the PATIENT key until the NEONATE LED is lit. Confirm that the NEONATE indicator on the front panel is lit. Set all desired alarm limits for neonate monitoring conditions.

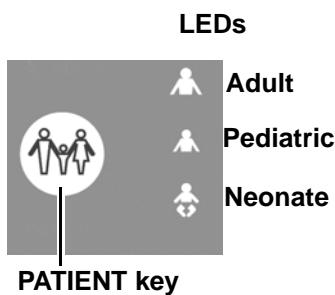

Alarm Volume This setting adjusts the volume of the audible alarm tone. Choices are 1 through 10 and *Off* (Where 1 is the softest and 10 is the loudest). A tone is generated at each volume level as the alarm volume setting is changed.

The factory hospital default setting is 4; the factory alternative care default setting is 3. The monitor returns to the value 2 upon a power cycle if the alarm volume had been turned off or set to 1.

Pulse Volume Sets the volume for the audible pulse tone from *Off*, and 1 through 10, with 1 being the softest and 10 the loudest. The factory default value is *Off*.

- High Pulse** Select the high alarm limit for pulse rate. Choices are 80 to 250 bpm and *Off*. Resolution is 1 bpm. The factory default value is 150 for Adult and Pediatric modes and 180 for Neonate mode.
- Low Pulse** Select the low alarm limit for pulse rate. Choices are off and 20 to 150 bpm and *Off*. Resolution is 1 bpm. The factory default value is 40 for Adult and Pediatric modes and 90 for Neonate mode.
- High SpO₂** Select the high alarm limit for SpO₂. Choices are 70-98%, and *OFF*. The factory default setting is *OFF* for both adult and neonatal modes. The resolution is 1% blood oxygen saturation. The factory default value is *OFF*.
- Low SpO₂** Select the low alarm limit for SpO₂. Choices are *OFF* and 1 to 98%. The factory default value is 90.
- If *LOW SPO2* is set to 98%, the *HIGH SPO2* alarm may not be changed from the *OFF* setting.
- The *LOW SPO2* setting returns to a minimum value of 90% after a power cycle.
- High Systolic** Select the high alarm limit for systolic blood pressure. Choices are 75 to 240 mmHg and *Off*. The factory default value is 200 for Adult and Pediatric modes and 140 for Neonate mode.
- Low Systolic** Select the low alarm limit for systolic blood pressure. Choices are 50 to 150 mmHg and *Off*. The factory default value is 50.
- High Diastolic** Select the high alarm limit for diastolic blood pressure. Choices are 50 to 180 mmHg and *Off*. The factory default value is 100 for Adult and Pediatric modes and 80 for Neonate mode.
- Low Diastolic** Select the low alarm limit for diastolic blood pressure. Choices are 15 to 50 mmHg and *Off*. The factory default value is 30 for Hospital defaults. The factory default value is 40 for Adult and Pediatric modes and 30 for Neonate mode for Alternate Care defaults.
- High MAP** Select the high alarm limit for mean arterial blood pressure. Choices are 70 to 200 mmHg and *Off*. The factory default value is 150 for Adult and Pediatric modes and 100 for Neonate mode for Hospital defaults. The default value for all modes is *Off* for Alternate Care defaults.
- Low MAP** Select the low alarm limit for mean arterial blood pressure. Choices are 25 to 125 mmHg and *Off*. The factory default value is 50 for Adult and Pediatric modes and 40 for Neonate mode for hospital defaults. The default value for all modes is *Off* for Alternate Care defaults.

High Temperature Select the high alarm limit for temperature. Choices are 87.8-105.0 degrees F (31.0-40.6 degrees C) and *Off*. The factory default value is 100.0 degrees F (37.8 degrees C).

Low Temperature Select the high alarm limit for temperature. Choices are 87.8-105.0 degrees F (31.0-40.6 degrees C) and *Off*. The factory default value is 93.0 degrees F (33.9 degrees C).

Parameter Setup Menu

Press the MENU key to enter menus. Press the UP/DOWN keys until the *PARAMETER SETUP* displays. Press the MENU key to enter the *PARAMETER SETUP*.

Press the UP/DOWN arrow keys to move through the parameter setup menu until the desired submenu item is displayed in the LCD window.

Press the MENU key to select that item, then use the UP/DOWN keys to scroll through the setting options for that item. When the desired setting is displayed on the LCD, press the MENU key to select that setting.

Temperature Mode Selects *PRED* (predictive) or *CONT* (continuous) mode of temperature monitoring. The factory default value is *PRED* and the monitor returns to predictive mode after each power cycle.

Degrees F/C Toggles between degrees Fahrenheit (F) and degrees Celsius (C) for the temperature display. The factory default value is Fahrenheit.

SpO₂ Search *506DN3 monitors only!* The search time is the length of time that the monitor searches for a valid SpO₂ signal before clearing the displayed SpO₂ value. Choices are 10, 20, 30 or 40 seconds. The factory default value is 20 seconds.

NIBP Tone Selects when the NIBP tone is generated. Choices are *NONE*, no tone is generated; *BEGIN*, a tone is generated at the beginning of an NIBP measurement; *END*, a tone is generated upon completion of an NIBP measurement; and *BOTH*, a tone is generated at the beginning and upon completion of an NIBP measurement. The factory default value is *NONE*.

SpO₂ Average Averaging time is the period of time over which the displayed SpO₂ percent value is averaged.

For monitors with DOX SpO₂, the available averaging times are 3, 6, 9, 12, 15, 18, and 21 seconds. The factory default value is 12 seconds.

For monitors with Nellcor SpO₂, the available averaging times are *F* (Fast) and *N* (Normal). The factory default value is *N*.

Printer Setup Menu

Press the MENU key to enter menus. Press the UP/DOWN key until the monitor displays *PRINTER SETUP*. Press the menu key to select the *PRINTER SETUP* menu. Press the UP/DOWN keys to move through the printer setup menu until the desired item setting is displayed in the LCD window. Press the MENU key to select that item, then use the UP/DOWN keys to scroll through the setting options for that item. When the desired setting is displayed on the LCD, press the MENU key to select that setting.

- On NIBP** The monitor prints data when an NIBP reading is taken. Choices are *ON* or *OFF*. The factory default is *On*.
- On Alarm** The monitor prints data during a medium level alarm limit violation. Choices are *ON* or *OFF*. The factory default is *OFF*.
- Interval** This sets the time interval for automatic interval printing of vital signs data. Choices are *10, 20, or 30 seconds; 1, 2, 5, 10, 15, 30, or 60 minutes; 2, 4, 8, 12, or 24 hours, and OFF*. The factory default is *OFF*.
- Print To** Sets the output device of the monitor. Use *Printer* for the internal printer of the 506N3 Series. External printing and downloading is available using the *Serial* setting. Choose *OFF* to disable printing.
- Serial** Sets the data format for the external serial port (for sending data to an external device). The choices are *TEXT, CSV, CUSP, and OFF*. See the *VitalCare 506N3 Series Operator Manual* for more information.
- Baud Rate** Sets the baud rate of the monitor. Selections are 2400, 4800, 9600, 19200, and 38400. The default is 19200 baud rate.

Configuration Menu

Press the MENU key to enter menus. Press UP or DOWN key to display *CONFIGURATION*. Press the MENU key to select the *Configuration* submenu.

Press the UP/DOWN keys to move through the configuration submenu until the desired item setting is displayed in the LCD window.

Press the MENU key to select that item, then use the up and down arrow keys to scroll through the setting options for that item. When the desired setting is displayed on the LCD, press the MENU key to select that setting.

- | | |
|------------------|--|
| Date | Sets the date format to <i>MM-DD-YYYY</i> (month-day-year) or <i>DD-MM-YYYY</i> (day-month-year). The factory default setting is <i>MM-DD-YYYY</i> . |
| Time | Sets the monitor time to <i>24-Hour</i> or <i>AM/PM</i> . The default is <i>24-Hour</i> . |
| Hour | Sets the current hour (24-hour format). |
| Minute | Sets the current minute. |
| Day | Sets the current day. |
| Month | Sets the current month. |
| Year | Sets the current year. |
| Contrast | Adjusts the LCD message bar contrast from 5% to 95% in 5% increments. The contrast changes as the adjustment is made. The factory default is 50%. |
| Temperature | Turns the temperature function <i>ON</i> or <i>OFF</i> . This automatically resets to <i>ON</i> when restarting the monitor. |
| SpO ₂ | Turns the SpO ₂ function <i>ON</i> or <i>OFF</i> . This automatically resets to <i>ON</i> when restarting the monitor. |
| NIBP | Turns the NIBP function <i>ON</i> or <i>OFF</i> . This automatically resets to <i>ON</i> when restarting the monitor. |
| Enable MAP | Enables (<i>ON</i>) or disables (<i>OFF</i>) MAP display on the monitor. Also removes MAP from the headers and printouts when set to <i>OFF</i> . The factory default is <i>ON</i> . |

International Configuration Settings

The language setting only appears in the *CONFIGURATION* submenu after the monitor has been started in the factory default mode (Press the MENU key during power up). This setting is intended to be set once upon arrival at a final destination. The language setting does not appear again until default settings are recalled again.

Language The monitor has language settings available in English, French, German, Italian, Spanish, Portuguese, Danish, and Dutch. The monitor must be restarted before the language setting change activates.

Trend Button Settings

Press and hold the TREND button to set the trend settings.

Interval Sets the interval of time you wish the data to print in the trend span. Choices are *1, 2, 5, 10, 15, 30, or 60 M* (minutes), and *Off*. The factory default setting is *1 M*.

NOTE: *Off* is not available if *FORMAT* is set to *NO BPT*.

Format Sets the format of trended data. Choices are *BP, BPT, NO BPT, LAST* and *ALL*. The factory default setting is *BPT*.

Span Sets the amount of trend data you wish to print. Choices are: *10, 15, 30, or 60 M* (minutes); *2, 4, 8, 12, or 24 H* (hours); and *ALL*. The factory default setting is *4 H*.

Patient Button Settings

Press the PATIENT button to select the patient mode. Choices are *Adult, Pediatric, and Neonatal*. The factory default setting is *Adult*.

Section 3 — Theory of Operation

System Architecture

The 506N3 Series circuitry consists of a Main Board, Display Board, LCD Module, SpO₂ Module, and NIBP module. Units with temperature also have a Temperature module with an Isolation Module. Units with an internal printer have a Printer Module. Units with Nellcor SpO₂ have an additional Carrier Board for the Nellcor module.

The Main Board, LCD module, and a Display Board are considered a Main Module. This module is located in the front panel of the 506N3 Series enclosure. Both the LCD module and the Display Board mount to the Main Board which, in turn, mounts to the front panel.

Affixed to the front panel is the membrane switch and overlay that connects directly to the Main Board.

The rear half of the enclosure houses the 6-Volt lead acid battery, AC-to-DC Power Supply, NIBP Module, optional Printer Module, optional SpO₂ Module, and optional Temperature Module. All non-power modules have electrical connections to the Main Board via miniature 2mm pitch cable assemblies.

The basic configuration of the 506N3 Series monitor consists of an NIBP module. The mechanical design of the enclosure permits configuration of the basic 506N3 Series monitor with optional modules of Temperature, Printer, and SpO₂ using the base monitor configuration.

The lead acid battery is contained in a compartment accessible with a tool. The design of the compartment prevents the 506N3 Series circuitry from being exposed when the battery compartment is opened. Thus the 506N3 Series monitor does not require recalibration or functional testing due to a possible tampering of critical electronics.

External connectors consist of:

- An RS-232 COM port,
- AC (Mains) Power,
- NIBP Comfort Cuff (pneumatic),
- SpO₂ sensor, and
- Temperature probe.

Electrical isolation of patient connections observes EN60601-1. To this end, isolated DC power supplies are contained on the DOX SpO₂ and TurboTemp Technologies employing an adapter or isolation boards: the Nellcor Carrier Board and the FasTemp® Isolation Board. Additional isolation is incorporated through a medical grade AC-to-DC power supply conforming to 4000VAC isolation and an isolated supply for the external COM function. This supply conforms to 4000VAC isolation.

The 506N3 Series consists of a modular architecture. The software design supports this hardware philosophy by employing an RTOS to simplify prioritization of the functions resident on the main processor.

Module Architecture

Main Board
(pn 91384A001/2/3)

The hardware design of the 506N3 Series monitor relies on multiple serial communication channels wherein the Main Board functions as the hub. Signal and display processing is off-loaded to the various vital signs technology modules, the Display Board, and the LCD Module. The Main Board collects the vital signs information, then stores, formats, and outputs the data either electronically through the external serial port or in hardcopy via the optional internal printer module.

There is a power supply section of the Main Board wherein regulated DC voltages are generated for various logic and analog functions as well as the battery charging function.

Display Board
(pn 91388A001)

The Display Board contains all seven-segment LED displays and their drivers. The Display Board connects to the Main Board via a dual row, 0.050-inch pitch stacking pin connector. Data to the displays is transmitted serially in a synchronous manner.

LED DISPLAYS

Three 0.53-inch amber LED displays indicate the Pulse Rate. Two 0.53-inch green LED displays indicate the SpO₂ percentage with a companion 10-segment green LED pulse bar. Two sets of three 0.53-inch red LED displays indicate Systolic (SYS) and Diastolic (DIA) NIBP pressures. Three 0.39-inch red LED displays indicate the Mean Arterial Pressure (MAP).

For units with optional temperature, five 0.39-inch red LED displays indicate the temperature, with the right-most digit dedicated to indicate C (Celsius) or F (Fahrenheit).

LED OVERLAY ICONS

Additionally, chip LEDs shall be used to illuminate front panel overlay icons. These include icons for the Battery indicator, AC Power indicator, No Sensor indicator, Alarm Silence indicator, and Patient Size indicators. Units with the optional Temperature feature also have Temperature Site indicators.

| | |
|---|---|
| NIBP Module (pn 93947A003) | This module connects to the Main Board. The upgraded NIBP algorithm firmware installed conforms to EN1060. |
| DOX Module (pn 91391A001) | This module is the Criticare Digital Oximetry circuit. The circuitry is configured in a physical geometry to be compatible with the Nellcor OxiMax® and Nellcor Carrier Board real estate. In this manner the DOX module and the Nellcor SpO ₂ module fit in the same location within the 506N3 enclosure and utilize the same cable assembly to connect to the Main Board. Additionally, the DOX Module provides electrical isolation of 1500VAC minimum through power and serial interface connections. The DOX SpO ₂ sensor connector is mounted directly onto the Module. |
| Nellcor Module (pn 83459B001/2) | <p>The Nellcor pulse oximetry module is a small printed circuit board assembly that provides the core components of a low power pulse oximeter system with OxiMax performance. It is designed for OEM use and supports the full line of Nellcor OxiMax sensors, including the new MaxFast™ forehead sensor.</p> <p>Nellcor OxiMax technology is a system that uses calibration data contained in Nellcor brand OxiMax sensors when calculating the patient's SpO₂. Using calibration data from the individual sensor rather than the pulse oximeter board significantly improves the accuracy of the information because the calibration coefficients used in the calculations are tailored to the information detected in the sensor.</p> |
| Nellcor Carrier Board (pn 91387A001) | The Nellcor Carrier board is designed to allow the Nellcor MP100 OxiMax module to mount directly on top in a mother/daughter board arrangement. The Nellcor Carrier board provides electrical isolation of 1500VAC minimum through power and serial interface connections. The Nellcor sensor connector is mounted directly onto the Carrier Board. |

Temperature Modules The 506N3 Series offers a choice of two leading predictive temperature technologies: FILAC FasTemp™ and Alaris TurboTemp®. Each operate in a similar manner.

Patient temperature sensing is accomplished by utilizing a negative-temperature coefficient (NTC) thermistor located in the probe tip. A heating element under algorithmic control heats the tip to accelerate the temperature measuring process.

Active circuitry on the temperature module converts the analog signals from the probe to a digital format, which is then used by the microprocessor located on the printed circuit board. Software algorithms executed in the microprocessor convert the digital information to a format for processing by the 506N3 main processor.

FASTEMP™ MODULE (PN 83460B001)

The FILAC FasTemp™ OEM Module is purchased from Tyco Healthcare/Kendall to utilize their fast predictive temperature algorithm.

ALARIS TURBOTEMP® MODULE (PN 91403A001)

Criticare Systems, Inc. produces the Alaris TurboTemp® module under license from Cardinal Health. This module utilizes the Alaris TurboTemp® predictive algorithm.

**FasTemp Isolation Board
(pn 91386A001/2)**

The FasTemp Isolation board is designed to provide electrical isolation of 1500VAC minimum through power and serial interface connections. This board is mounted in proximity to the FILAC FasTemp module but not physically attached. Electrical connections to the FasTemp board are:

1. Power;
2. RS-232 serial; and
3. "TALK Mode" control line.

Printer Module

The printer module consists of the pn 91389A002 Printer Board and the Seiko LTP1245 printer, all mounted within a plastic enclosure. The enclosure is mounted in place of a "blank" panel on the main 506N3 enclosure when the printer option is selected. Electrical connection to the Main Board via a ribbon cable supplies both power and digital control lines.

Block Diagram

The following block diagram is provided for the general understanding of the 506N3 Series monitoring system.

The diagram below shows the system module interconnections.

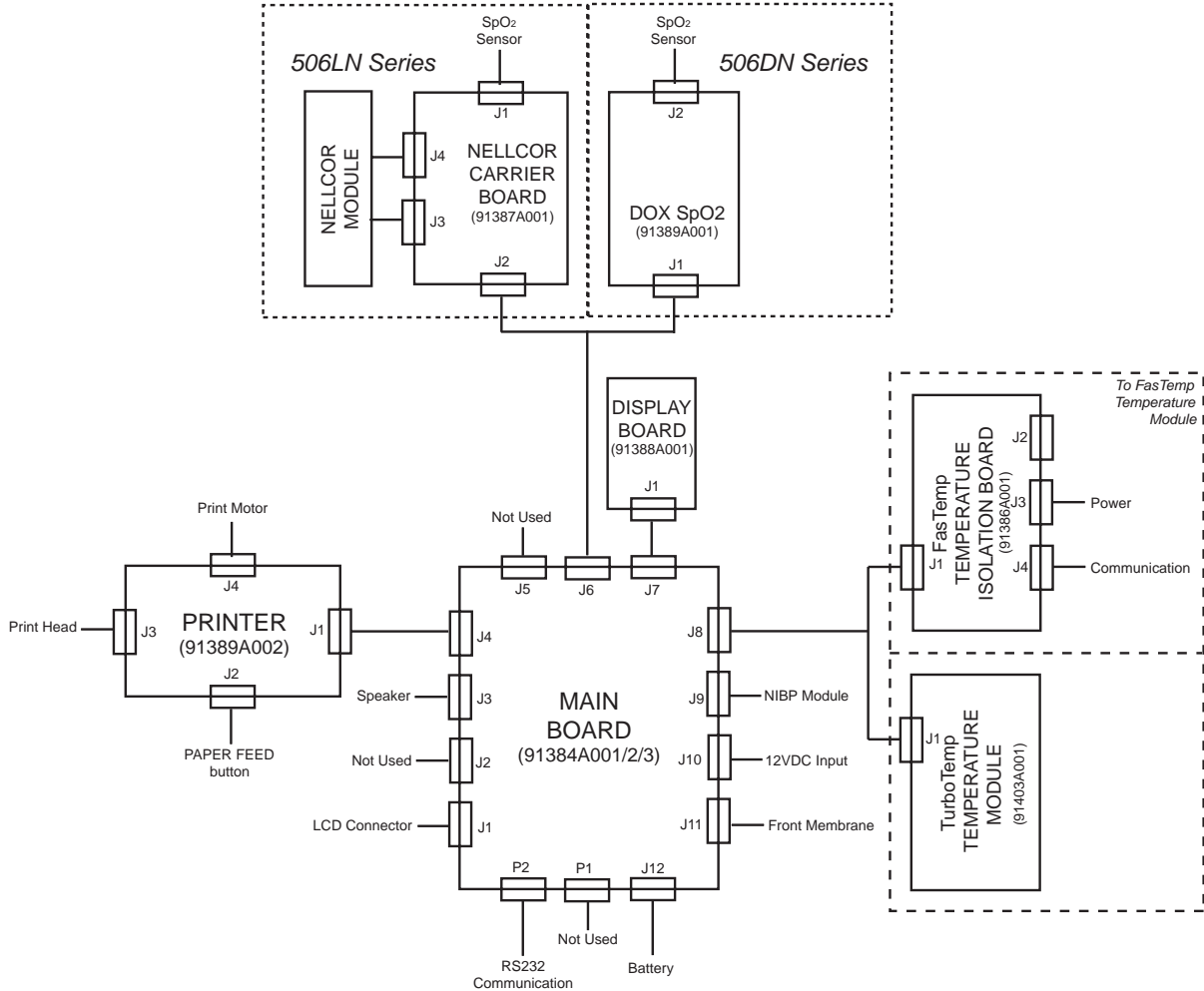

Figure 3-1: 506N3 Series Board Interconnect Block Diagram

Section 4 — Cleaning and Disinfecting

Cleaning and Disinfecting



⚠ WARNING ⚠

- Shock Hazard! Turn the power off and disconnect the AC power before cleaning the monitor and accessories.
- Shock Hazard! Never immerse the monitor. The monitor has an internal power source that is active when the unit is unplugged.

Do not use abrasive cleaners on the monitor or on any sensors or probes. Abrasive cleaners can damage the monitor and accessories.

The exterior surface of the monitor, except for the display screen, you may wipe clean with alcohol and dry with a soft, dry cloth. It is best to use a cotton cloth to clean the monitor. Paper towels or tissues can scratch the surface of the display.

Do not use full strength alcohol on the LCD display. Repeated use of strong cleaners can damage the screen. Clean the display window by wiping it with a clean, soft, lint-free cloth sprayed with common glass cleaner. Do not spray glass cleaner directly on the display.

Blood Pressure Cuffs

To clean the reusable blood pressure cuff wipe it with a damp cloth or sponge. If necessary, disinfect the cuff with 70% alcohol, mild bleach solution, or other disinfectant. Disposable blood pressure cuffs are for single patient use and are not intended to be disinfected.

Sterilize the cloth cuff and neoprene bag with commercially available disinfectants such as ethylene oxide (EtO). Rinse thoroughly to remove any residual disinfectants. Do not allow liquids to enter the neoprene bag. You may sterilize the cloth cuff in an autoclave.

If the cuffs become grossly soiled with blood or other body fluids, you should launder the cloth cuffs by hand or machine. Remove the neoprene inflation bag before you launder or sterilize the dacron cloth cuff. Feed the inflation tube back through the hole and then pull out the cloth flap.



Figure 4-1: Remove the Inflation Bag

Roll up the inflation bag and slide it out the open slot in the cloth cuff. Be sure to observe the following laundering precautions (do NOT launder disposable cuffs and neoprene inserts.):

- Remove the inflatable bag from the cuff before you launder or sterilize the cuff.
- Strong bleach solutions will damage the cuff.
- Temperatures over 275° F (135° C) will damage the cuff.
- Close the Velcro® fastener before you launder the cuff.
- Soaking the cuff in dark-colored solutions may stain or discolor the cuff.

Hand laundering (as opposed to machine laundering) prolongs the life of the cuff. Wash the cuff in warm, soapy water. Rinse the cuff thoroughly. After cleaning the cuff, allow the cuff to air dry, then insert the inflation bag in the cuff.

DOX Pulse Oximeter Sensors

CAUTION

- Do not immerse any Criticare pulse oximeter sensor connector in any liquid. Doing so may damage the connector.

The SpO₂ sensor may be wiped clean with alcohol. The SpO₂ sensor may be disinfected by placing the paddles and cable in a 2% glutaraldehyde solution. Place only the sensor paddles and cable in the solution.

OxiMax Pulse Oximeter Sensors

D-YS SENSOR

Remove the disposable wrap from the D-YS by peeling it away from the sensor. The sensor may be surface-cleaned with a solution such as 70% isopropyl alcohol. If low-level disinfection is required, use a 1:10 bleach solution. Do not use undiluted bleach (5%~5.25% sodium hypochlorite) or any cleaning solution other than those recommended here because permanent damage to the sensor could occur.

CAUTION

- Do not expose connector pins to cleaning solution as this may damage sensor.

To clean or disinfect the sensor using the recommended wipe method:

1. Saturate a clean, dry gauze pad with the cleaning solution. Wipe all surfaces of the sensor and the cable with this gauze pad.
2. Saturate another clean, dry gauze pad with sterile or distilled water. Wipe all surfaces of the sensor and cable with this gauze pad.

3. Dry the sensor and cable by wiping all surfaces with a clean, dry gauze pad.

To clean or disinfect the sensor using the recommended soak method:

1. Place the sensor in the cleaning solution, such that the sensor head(s) and desired length of cable are completely immersed.

⚠ CAUTION ⚠

- Do not immerse the connector end of the cable as this may damage the sensor.
2. Dislodge air bubbles by gently shaking the sensor and cable.
 3. Soak the sensor and the cable for 10 minutes.
 4. Remove from cleaning solution.
 5. Place the sensor and the cable in room temperature sterile or distilled water for 10 minutes.
 6. Remove from the water.
 7. Dry the sensor and cable by wiping all surfaces with a clean, dry gauze pad.

⚠ CAUTION ⚠

- Using excessive force when removing the disposable wrap may damage the sensor.
- Do not sterilize by irradiation, steam, or ethylene oxide (EtO).

DS-100A SENSOR

The DS-100A may be surface-cleaned by wiping it with a solution such as 70% isopropyl alcohol. If low-level disinfection is required, use a 1:10 bleach solution. Do not use undiluted bleach (5%~5.25% sodium hypochlorite) or any cleaning solution other than those recommended here because permanent damage to the sensor could occur.

To clean or disinfect the sensor:

1. Saturate a clean, dry gauze pad with the cleaning solution. Wipe all surfaces of the sensor and cable with this gauze pad.
2. Saturate another clean, dry gauze pad with sterile or distilled water. Wipe all surfaces of the sensor and cable with this gauze pad.
3. Dry the sensor and cable by wiping all surfaces with a clean, dry gauze pad.

⚠ CAUTION ⚠

- Do not sterilize by irradiation, steam, or ethylene oxide (EtO).

EAR CLIP

CAUTION

- To avoid damage to the Dura-Y sensor, remove the sensor from the ear clip before cleaning either piece. To clean the sensor, refer to the instructions in the Dura-Y sensor Directions for Use.
- Do not sterilize the ear clip by irradiation, steam, or ethylene oxide.

The ear clip may be cleaned by wiping or soaking it (for 10 minutes) in isopropyl alcohol (70%). If the ear clip is soaked, be sure to rinse it with water and air dry it prior to use on the next patient.

After each cleaning and prior to use again, the ear clip should be inspected for cracking or breakage, and discarded if any defects are noted.

Discard if loss of spring tension allows slippage or movement of the ear clip from its proper position on the ear lobe or pinna. Slippage caused by loss of spring tension may result in inaccurate sensor readings.

Temperature Probes To clean the probe tip, use a damp cloth with diluted detergent.

Accidental Wetting

WARNING

- Shock Hazard! The monitor is an AC powered device and an immersed monitor presents a danger to anyone who handles the device.

The action to be taken following accidental wetting of the equipment is as follows:



1. Turn the power off! Disconnect the AC power from the monitor.
2. If monitoring a patient, transfer the patient to another monitor as quickly as possible.
3. Use a clean, dry towel or cloth to remove the liquid from the monitor housing.
4. A service technician should inspect the monitor as soon as possible.
5. If the internal mechanism is saturated, allow the liquid to drain out for 24 hours before shipping.
6. If liquid has entered the monitor, it needs to be dried and cleaned internally. Full testing is required before the monitor can be used. Contact the Criticare Service Department as soon as possible.

Time is critical! The longer any liquid remains in the monitor, the more damage it can do. It is important to service the monitor immediately after any liquid is spilled into it.

Section 5 — Preventative Maintenance

Incoming Inspection

You should inspect all new monitors upon arrival for shipping damage before you place them into operation. The monitor should be free from dents, cracks, or other physical damage. The quality inspection seal of the monitor should be unbroken; this indicates that the monitor has been tested according to the manufacturer's specifications.

If further incoming inspection or testing is desired, the manufacturer recommends you use "Speaker Performance, Alarms Verification" in this section as an incoming inspection test. You may perform additional electrical safety testing with "Electrical Safety Tests" in this section as part of an incoming inspection in accordance with the policies of the health care provider.

Maintenance Schedule

| | |
|----------------|--|
| Every Patient | <ul style="list-style-type: none">• Clean and disinfect the NIBP cuff and the SpO₂ cable as needed.• Inspect the accessories for damage. |
| Every Day | <ul style="list-style-type: none">• Charge the monitor's battery as necessary. |
| Every 3 Months | <ul style="list-style-type: none">• Clean the exterior of the unit (or clean as needed).• Inspect the monitor and AC (mains) cord for damage. |
| Every Year | <ul style="list-style-type: none">• Perform the annual safety tests that are described in this section. |

Long-Term Storage

No special preparation is necessary for long term storage of the monitor. Although the battery does not have to be removed from the monitor for long term storage, the battery does drain to an unrecoverable state after 3 months without periodic charging.

Service Checks

If the monitor shows any signs of physical damage, contact the Criticare Service Department for repair.

Technical Service (US): (800) 458-2697

International Customer Service: (262) 798-8282

Calibration

No periodic calibration of the monitor is necessary. It is recommended to perform an NIBP calibration verification as part of the annual safety testing.

Serviceable Components

The only user-serviceable parts inside the monitor are the battery and the fuses. Refer all other maintenance inside the monitor to a qualified technician.

For more information about troubleshooting power problems, refer to “Troubleshooting” in Section 8.

Battery Removal/ Replacement

BATTERY SAFETY

Although the battery requires no maintenance, you should allow the battery to fully charge at least once every three months.

For optimal battery performance, the battery should never be left in a drained state for any period longer than 24 hours.

⚠ CAUTION ⚠



- Do not open the case. Sensitive electronic components may be damaged by electrostatic discharge. Opening the case requires an electrostatic discharge (ESD) protected work bench.
- Shock hazard. The interior of the case contains exposed circuitry.
- Do not short circuit the battery terminals! The resulting high-current discharge can cause burns.
- Charge the battery completely after extended battery use to ensure a fully-charged battery is available for the next use.
- Explosion hazard! Keep lighted cigarettes, sparks, and flames away from the battery.
- The battery contains sulfuric acid electrolyte which can cause severe burns and eye damage, as well as illness from sulfur oxide fumes.
- Do not crack, cut, burn, or dissolve (with solvents) the battery case. Damaging the battery case can cause the release of sulfuric acid. If sulfuric acid is released from the battery, wear eye protection and rubber gloves to handle the battery, and use a solution of baking soda in water to neutralize the sulfuric acid.
- The used battery is a potential environmental hazard and must be disposed of properly. Dispose the old battery in accordance with local and federal laws. Do not incinerate.

REMOVE THE BATTERY

1. Turn the monitor off and disconnect the monitor from the AC (Mains) power source.
2. Remove the four (4) Phillips screws from the battery cover on the back of the monitor. Remove the battery cover.

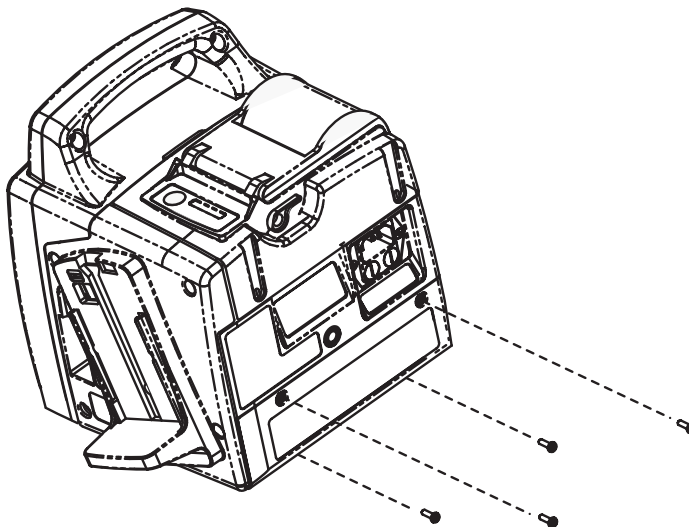
**Figure 5-1: Remove Screws**

3. Remove the battery (pn 80518B001) from the monitor.

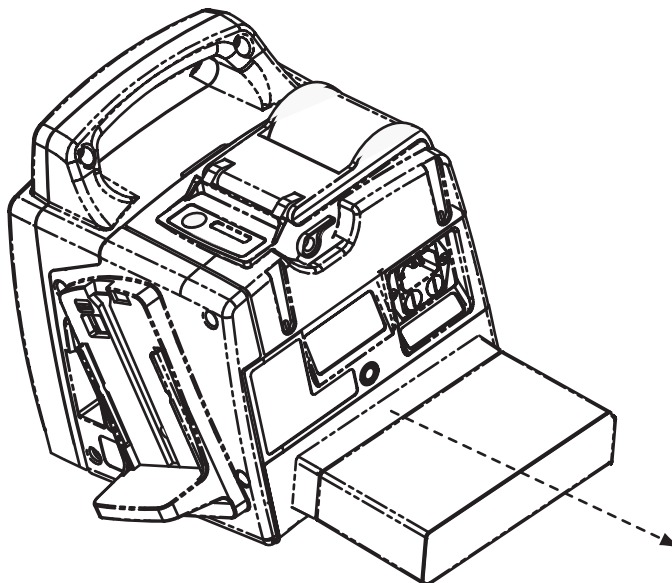
**Figure 5-2: Remove Battery**

4. Label and remove the cables connected to the battery.

NOTE: Printing faces inward.

REPLACE THE BATTERY

1. Attach the battery cables to the new battery (pn 80518B001).

IMPORTANT: Connect the red battery cable to the positive battery terminal and the black cable to the negative battery terminal.

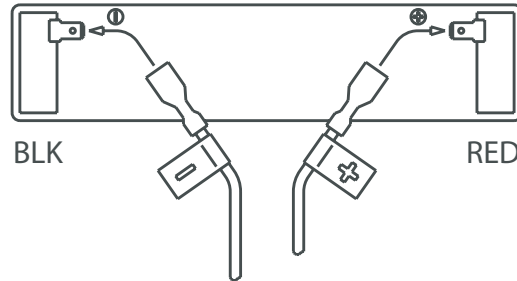

Figure 5-3: Connecting the Battery

2. Slide battery into the battery bay.
3. Reattach the battery cover with the four (4) screws removed earlier.

Fuse Removal/ Replacement

There are two AC power fuses located at the rear of the monitor directly below the AC power entry socket.

- Use 0.5A 250V time delay fuses (T 500MA L 250V).
1. With a flat blade screwdriver, turn the fuse cover(s) out.
 2. Gently pull the fuse cover(s) with fuse(s) out of the fuse assembly.

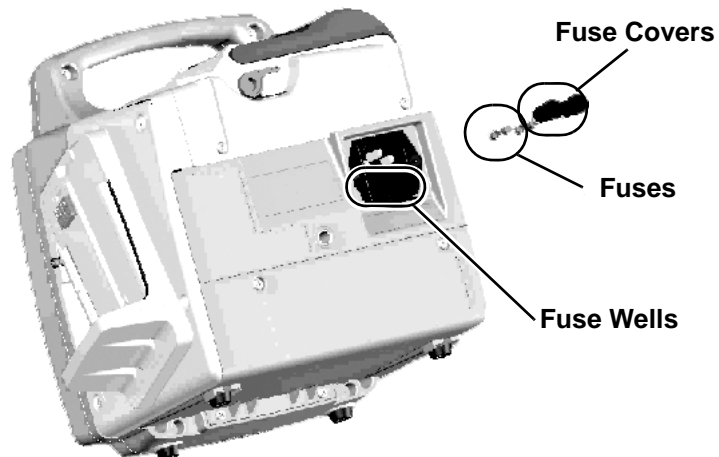

Figure 5-4: 506N3 Series Fuses

3. Gently pull the fuse(s) out of the fuse cover(s).
4. Reassemble in reverse order.

Annual Testing

You may perform the following tests as part of a periodic safety check. The following safety tests are designed so that the monitor's quality/warranty seal does not need to be broken. If the monitor fails any portion of these tests contact Criticare Support for additional information.

Descriptions of service tests can be found in "Service Testing & Calibration" in Section 6. Some tests may require specialized equipment.

Accessory Testing Check the patient cables (temperature cables, SpO₂ cable, etc.) monthly for damage, loose wires/connections, loose connectors, cracked housing, etc. Check the cuffs for leakage as part of the NIBP verification.

Functional and Safety Testing Annual testing should include electrical safety testing, the withstanding voltage, and electrical leakage tests. Additional functional tests and verifications are provided that you may perform as designated by hospital protocols or as necessary.

A complete list of functional and safety tests are included here.

1. Electrical Safety Tests
 - a. Withstanding Voltage (Hi-Pot)
 - b. Electrical Leakage
2. Functional Tests
 - a. System Check (LED test)
 - b. Speaker Performance and Alarm Verification
 - c. Power Supply Performance
 - d. Printer Performance
3. Vital Sign Modules Verifications
 - a. NIBP
 - b. Oximeter (SpO₂)--DOX or Nellcor
 - c. Temperature

Equipment and Tools The following procedures assume that the technician has an ESD safe workbench available, a set of electronic hand tools, and a digital multimeter with a 10 amp setting. You need a withstanding voltage tester (Hi-Pot), an oscilloscope, and an electrical leakage tester for safety testing. At the beginning of each test special equipment may be listed. You may also need a variety of customized cables, clips, and test fixtures to complete all the tests.

The following tools are needed for these procedures:

- Set of hand tools,
- Digital multimeter (10A),
- Oscilloscope,
- Power supply,
- Setra 350-1 (or equivalent) manometer with Tee,
- Dynatech 232D (or equivalent) leakage tester,
- Dynatech cufflink NIBP simulator with neonatal and adult cuffs,
- 7512DT Associated Research withstanding voltage tester (or equivalent),
- Smart Sat SS-100A pulse oximetry analyzer (or equivalent),
- Computer with CSI NIBP Service program (97082A003) and WFSDLOAD program,
- 506N3 SpO₂ Hi-Pot cable (units with DOX SpO₂),
- 506N3 SpO₂ leakage cable (units with DOX SpO₂),
- 506N3 FasTemp Hi-Pot cable (units with FasTemp),
- 506N3 FasTemp leakage cable (units with FasTemp),
- 506N3 Nellcor Hi-Pot cable (units with Nellcor SpO₂),
- 506N3 Nellcor leakage cable (units with Nellcor SpO₂),
- 506N3 TurboTemp Hi-Pot cable (units with TurboTemp),
- 506N3 TurboTemp leakage cable (units with TurboTemp),
- Screw in order to Hi-Pot to case,
- Serial cable with null modem,
- Nellcor SpO₂ cable and extender (units with Nellcor SpO₂),
- AC (Mains) Power cord,
- 700 cc factory test block,
- Cat 511SD finger sensor (or equivalent) with optical load (foam packing peanut),
- Oral Temperature Probe (Blue) (units with FasTemp),
- Rectal Temperature Probe (Red) (units with FasTemp),
- Cat 1546 simulated temperature plug and chamber (units with FasTemp),
- Alaris Temp Probe (units with TurboTemp), and
- Alaris No. TE 1811 Probe Simulator (units with TurboTemp).

To order Alaris Probe Simulator, contact Cardinal Health/Alaris Customer Service. 1-800-482-4822.

Test Fixtures DOX SpO2 HI-POT TEST FIXTURE

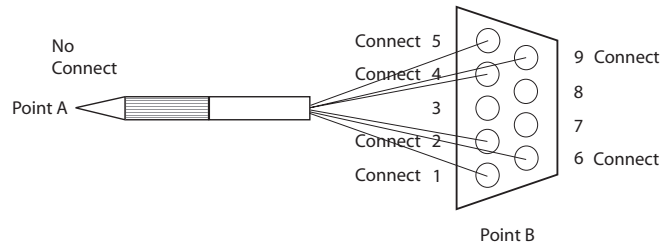

DOX SpO2 LEAKAGE TEST FIXTURE

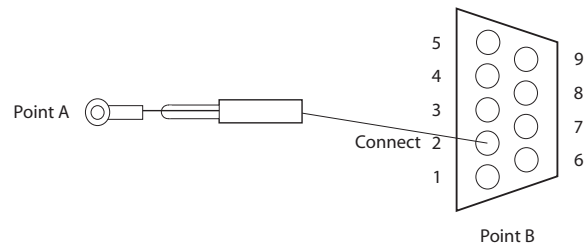

NELLCOR HI-POT TEST FIXTURE

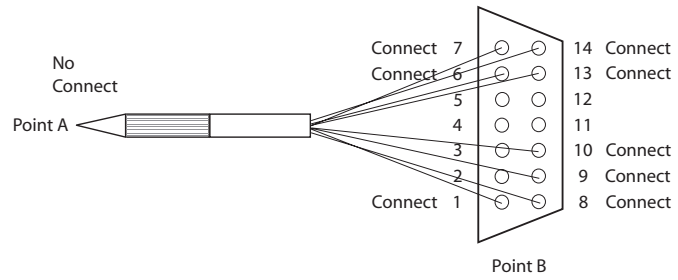

NELLCOR LEAKAGE TEST FIXTURE

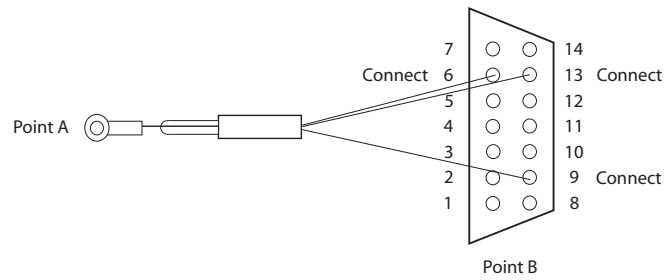

FASTEMP HI-POT TEST FIXTURE

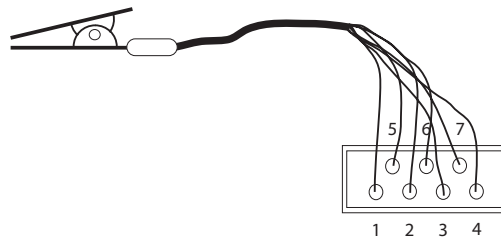

FASTEMP LEAKAGE TEST FIXTURE

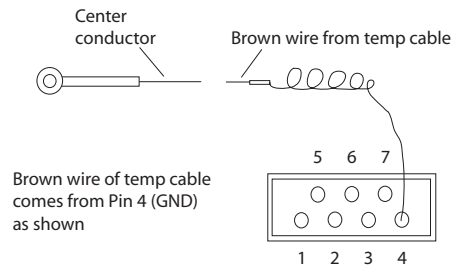

TURBOTEMP HI-POT TEST FIXTURE

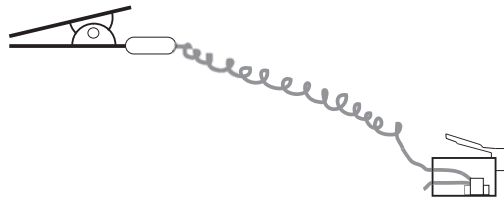

TURBOTEMP LEAKAGE TEST FIXTURE

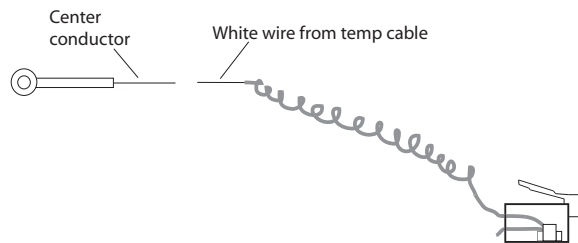

Electrical Safety Tests

Perform this test whenever the monitor housing is opened before using the monitor on patients.

Withstanding Voltage Test (Hi-Pot)



WARNING

- High Voltage! The following test procedure requires working with exposed electrical circuits and should only be attempted by experienced technicians.

Equipment Needed

This test requires a Kikusui 7512DT Associated Research (or equivalent) Hi-Pot tester. The tester should be rated for 4000 VAC maximum.

Setup Hi-Pot Tester

- Hi limit = 1mA
- Lo Limit =0.0uA
- Arc Fail = OFF
- Arc Sense = 5
- Ramp Hi = Off
- Charge Lo = 0.0 uA
- Ramp Time = 1 second
- Dwell Time =1 second
- AC/DC =DC

Hi-Pot Performance Test **NOTE:** Do not power up the 506N3 Series monitor during the Hi-Pot steps.

The following table is an aid to assist in determining which monitor is being tested and which steps need to be performed:

| Model (CAT) Number | Assembly Part Number | SpO ₂ Cable Type | Temperature Cable Type |
|--------------------|----------------------|-----------------------------|------------------------|
| 506DN3 | 93975A001 | DOX | — |
| 506DNP3 | 93975A002 | DOX | — |
| 506DNT3 | 93975A003 | DOX | FasTemp |
| 506DNTP3 | 93975A004 | DOX | FasTemp |
| 506LN3 | 93975A005 | Nellcor | — |
| 506LNP3 | 93975A006 | Nellcor | — |
| 506LNT3 | 93975A007 | Nellcor | FasTemp |
| 506LNTP3 | 93975A008 | Nellcor | FasTemp |
| 506DNV3 | 93975A009 | DOX | TurboTemp |
| 506DNVP3 | 93975A010 | DOX | TurboTemp |
| 506LNV3 | 93975A011 | Nellcor | TurboTemp |
| 506LNVP3 | 93975A012 | Nellcor | TurboTemp |
| 506N3 | 93975A020 | — | — |
| 506NP3 | 93975A021 | — | — |
| 506NT3 | 93975A022 | — | FasTemp |
| 506NTP3 | 93975A023 | — | FasTemp |
| 506NV3 | 93975A024 | — | TurboTemp |
| 506NVP3 | 93975A025 | — | TurboTemp |

ALL MODELS

1. Connect the 506N3 Series monitor to the measurement receptacle of the Hi-Pot tester. Test “Hot/Neutral” to “Ground” at 2512VDC.
2. Install a screw into the roll stand-mounting insert located on the rear of the enclosure. Attach the ground test lead of the Hi-Pot tester to the screw and the red test lead to “Hot/Neutral.” Test at 2512VDC.

MODELS WITH DOX SpO₂

1. Connect the DOX SpO₂ Hi-Pot cable to the ground test lead of the Hi-Pot tester and connect to the SpO₂ connector on the monitor. Attach the red test lead to “Hot/Neutral” and test at 4242VDC.
2. Connect the DOX SpO₂ Hi-Pot cable to the red lead of the Hi-Pot tester and connect the ground test lead to the Hi-Pot tester to the DB9 shell of the 506N3. Test at 2121VDC.

MODELS WITH NELLCOR SpO₂

1. Connect the Nellcor SpO₂ Hi-Pot cable to the ground test lead of the Hi-Pot tester. Attach the red test lead to “Hot/Neutral.” Test at 4242VDC.
2. Connect the Nellcor SpO₂ Hi-Pot cable to the red lead of the Hi-Pot tester and connect the ground test lead of the Hi-Pot tester to the DB9 shell of the 506N3. Test at 2121VDC.

MODELS WITH FASTEMP TEMPERATURE

1. Connect the FasTemp™ Hi-Pot cable to the ground test lead of the Hi-Pot tester. Attach the red test lead to the Hot/Neutral. Test at 4242VDC.
2. Connect the FasTemp™ Hi-Pot cable to the red lead of the Hi-Pot tester and connect ground test lead of the Hi-Pot tester to the DB9 shell of the 506N3. Test at 2121VDC.
3. *If the monitor has DOX SpO₂,* connect the red lead of the Hi-Pot tester to the DOX SpO₂ Hi-Pot cable and connect the ground test lead of the Hi-Pot tester to the FasTemp™ cable. Test at 2121VDC.

If the monitor has Nellcor SpO₂, connect the red lead of the Hi-Pot tester to Nellcor SpO₂ cable and connect ground test lead of the Hi-Pot tester to the FasTemp™ cable. Test at 2121VDC.

MODELS WITH TURBOTEMP TEMPERATURE

1. Connect the TurboTemp™ Hi-Pot cable to the ground test lead of the Hi-Pot tester. Attach the red test lead to “Hot/Neutral.” Test at 4242VDC.
2. Connect the TurboTemp™ Hi-Pot cable to the red lead of the Hi-Pot tester and connect the ground test lead of the Hi-Pot tester to the DB9 shell of the 506N3. Test at 2121VDC.
3. *If the monitor has DOX SpO₂*, red lead of the Hi-Pot tester to the DOX SpO₂ Hi-Pot cable and connect the ground test lead of the Hi-Pot tester to the TurboTemp™ cable. Test at 2121VDC.

If the monitor has Nellcor SpO₂, connect the red lead of the Hi-Pot tester to the Nellcor SpO₂ cable and connect the ground test of the Hi-Pot tester to the TurboTemp™ cable. Test at 2121VDC.

Leakage Testing This test requires a Dynatech 232D Safety Analyzer (or equivalent) leakage testing device.

Setup Procedure (Self-Test) Perform a self test, if applicable, to ensure proper operation of the leakage tester. If the self test fails, don't proceed with this test.

For Dynatech 232D only:

1. Perform a self test on the Dynatech 232D. Set the MODE switch to SELF test. The display should read 1000 (±20) and the CURRENT SOURCE ACTIVE lamp should be on.

⚠ CAUTION ⚠

- If these conditions are not met do not continue with the leakage test.
2. Set the MODE switch on the Dynatech to L1-L2. The display should read 220 to 240 VAC (or 110 to 130 VAC if supply voltage is 120 VAC). Set the MODE switch to L1-GND. The display should read no more than 5% of the previous line voltage measurement. Set the MODE switch to L2-GND. This reading should be the same as the first reading, ±5 VAC.

Leakage Procedure **NOTE:** The monitor must be on throughout the leakage test. This test should be performed at a supply voltage of 230VAC. If supply voltage is 120VAC, then acceptable leakage current limits are one-half the value stipulated.

NOTE: If attaching acceptable leakage measurements to the check sheet, check "PASS" on each step completed.

1. Connect the monitor to the measurement receptacle of the leakage tester.
2. Configure the leakage tester to test internal case leakage (Dynatech 232D: MODE = CASE LEAKAGE/GROUND CONDUCTOR). Record measurements on the check sheet for the following:
 - Normal Polarity (<100uA)
 - Reverse Polarity (<100uA)
 - Normal Polarity, Open Neutral (<500uA)
 - Reverse Polarity, Open Neutral (<500uA)
3. Configure the leakage tester to test external case leakage (Dynatech 232D: MODE = CASE LEAKAGE/EXT. LEAD). Clip the external leakage test lead to the DB9 shell of the monitor. Record measurements on the check sheet for the following:
 - Normal Polarity (<100uA)
 - Reverse Polarity (<100uA)
 - Normal Polarity, Open Ground (<500uA)
 - Reverse Polarity, Open Ground (<500uA)
4. *If the monitor has DOX SpO₂:* Connect the DOX SpO₂ leakage cable to the LA terminal on leakage tester.

If the monitor has Nellcor SpO₂: Connect the Nellcor SpO₂ leakage cable to the LA terminal on leakage tester.

Record the measurement on the check sheet or attach print out of the acceptable test result to the check sheet and test.

Configure the leakage tester to measure the patient connection to GND leakage. (Dynatech 232D: MODE = ECG, LEADS = ALL TO GND).

- Normal Polarity (<10uA)
 - Normal Polarity, Open Ground (<50uA)
5. Remove the SpO₂ cable

6. *If the monitor has Temperature:* Connect the FasTemp or TurboTemp leakage cable to the RA terminal on leakage tester. Record the measurement on the check sheet or attach print out of the acceptable test result to the check sheet and test. Configure the leakage tester to measure the patient connection to GND leakage. (Dynatech 232D: MODE = ECG, LEADS = ALL TO GND).
 - Normal Polarity (<10uA)
 - Normal Polarity, Open Ground (<50uA)
7. *If the monitor has Temperature:* Configure the leakage tester to measure patient interlead leakage. (Dynatech 232D: MODE = ECG, LEADS = RA-LA).
 - Normal Polarity (<10uA)
 - Normal Polarity, Open Ground (<50uA)

⚠ WARNING ⚠

- Hazardous voltage are present on the test leads. Do not touch these leads or the monitor while performing this test.
8. *If the monitor has DOX SpO₂:* Connect the DOX SpO₂ leakage cable to the LA terminal on leakage tester.

If the monitor has Nellcor SpO₂: Connect the Nellcor SpO₂ leakage cable to the LA terminal on leakage tester.

Record the measurement on the check sheet or attach print out of the acceptable test result to the check sheet and test. Configure the leakage tester to measure patient isolation. (Dynatech 232D: MODE = ECG, LEADS = ISOLATION TEST)

- Normal Polarity (<50uA) Press the isolation button.
9. *If the monitor has Temperature:* Connect the FasTemp or TurboTemp leakage cable to the RA terminal on leakage tester. Record the measurement on the check sheet or attach print out of the acceptable test result to the check sheet and test. Configure the leakage tester to measure patient isolation. (Dynatech 232D: MODE = ECG, LEADS = ISOLATION TEST)
 - Normal Polarity (<50uA) Press the isolation button.

Functional Tests

System Check Confirm the proper start up of the monitor. No cable should be attached to the external serial port during this test.

1. Press the POWER key to start the monitor. The monitor performs a short LED test on start up. Check each numerical display for missing segments. The alarm, no sensor detected, and patient size icons should also illuminate briefly during the test.

The monitor displays the following messages:

CRITICARE SYSTEMS INC.

506N3 SERIES

REVISION x.x (C) 200X

Confirm that the background of the LCD display illuminates a light blue color when the monitor turns on. The backlight turns off after 20 seconds if there is no monitoring activity or alerts.

2. Hold the MENU key while you restart the monitor. The reset to defaults message appears. Depending on configuration of the unit, this message may appear as *USER DEFAULTS*, *HOSPITAL DEFAULTS*, or *ALT. C. DEFAULTS*.
3. Press the MENU key and press the UP/DOWN arrow keys to scroll to the *CONFIGURATION* menu. Press the MENU key to enter the *CONFIGURATION* menu.
4. Press the UP/DOWN arrow keys to scroll to *CONTRAST*. Check the LCD *CONTRAST* setting. Adjust the contrast as necessary.
5. Continue in the *CONFIGURATION* menu. Ensure the time and date are correct.

For models including the optional printer module:

1. Press the PRINT key to test the printer. The monitor should print the title "CSI 506N3 Series REV x.x."
2. Confirm that the current date and time prints correctly below the title. Additional text also prints to provide space for the entry of patient information.
3. Press the PAPER FEED key and confirm that the paper advances by approximately six blank lines.

**Speaker Performance,
Alarms Verification**

This applies to all 506N3 Series monitors. To verify alarm circuitry:

1. Set the alarm volume to 10 in the *ALARMS* menu.
2. In the *CONFIGURATION* menu, turn off the temperature monitoring module. The LEDs for the temperature display should go blank.
3. With no cuff attached press the NIBP START/STAT/STOP key. The monitor attempts to inflate and responds with a message: *BP: CHECK CUFF*.
4. Listen for the low level alarm tone. It is a burst of two pulses at the same pitch. The bursts should repeat every 10 seconds.
5. Set the alarm level to 1 and cause another *CHECK CUFF* alarm. The volume should be decreased but still audible.
6. Set the alarm volume to OFF and cause another *CHECK CUFF* alarm. No alarm tone should be audible. Confirm that the alarm bell indicator LED flashes.
7. Return the alarm volume setting to 4.
8. In the *CONFIGURATION* menu, turn on the temperature module and turn off the NIBP monitoring module. The LEDs for the temperature display should light up and the NIBP display should go blank.
9. Confirm that no probe cable is connected to the monitor. Check the informational message on the LCD display. The message *TEMP: NO PROBE* should appear. There should be no alarm tone.
10. Attach a temperature simulator to the temperature connection (set to 98.6°F). The message *TEMP:NO PROBE* should go away. Ensure the probe is withdrawn from the probe chamber/well.
11. Check the temperature alarm settings and access.
12. If unit has TurboTemp temperature, set the simulator to 102°F. If the unit has FasTemp Temperature, only 98.6°F is available.
13. Listen for the medium level alarm tone. It should appear at a higher pitch than the low level alarm tone. It is a burst of three pulses all at the same pitch. The bursts should repeat every 25 seconds.

14. Access the *ALARM VOLUME* located in the *ALARMS MENU*. Press the MENU key. Select *ALARM MENU*. Press the MENU key again. *ALARM VOLUME <- 4* should appear. Press MENU key again and the arrow turns (*ALARM VOLUME -> 4*). Verify an audible change from 0 to 10 with each volume level setting.
15. Press the alarm SILENCE key. Verify that a red LED lights up the alarm silence indicator on the front membrane. Press and hold the alarm SILENCE key. Verify the red LED flashes continuously and all alarms are silenced.
16. Restart the monitor to reset the NIBP module to *ON*.

Power Supply Performance This applies to all 506N3 Series monitors.

1. Verify the green AC LED lights up the AC power symbol on the front membrane when the monitor is plugged into the AC inlet.
2. Verify the monitor powers up on AC only.
3. Verify the monitor powers up on DC only with a battery.

Printer Performance This applies to all 506N3 Series monitors.

1. Press the PRINT button when in the normal operating screen. Observe that the monitor prints out the currently displayed information.

NOTE: For non-printer units, attached a test printer to the unit and verify that the monitor prints out what is currently displayed information.

Monitoring Module Verification

NIBP Verification This applies to all 506N3 Series monitors. The NIBP verification requires Dynatech Nevada NIBP Analyzer. Connect the 506N3 Series monitor to a Dynatech Nevada NIBP Analyzer set for the following operation.

NIBP Analyzer Settings

Adult 120/80 (90); Heart Rate 120 bpm

Pressure Adjustments: Gain 100%; Shift 4

Use a tee connection with an adult dummy cuff. Connect to the 0-300 mmHg port of the NIBP analyzer. A neonatal dummy cuff is also required for complete testing.

It is recommended that the actual cuffs (to be used with the monitor) are setup as dummy cuffs for this verification. Wrap the cuff snug around a sturdy cylinder.

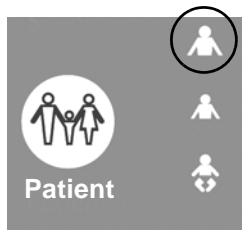

1. Connect the monitor to an AC power source and turn on the monitor. Set the monitor to the *ADULT* Mode (Adult Patient) by pressing the PATIENT key until the ADULT icon illuminates.
2. Press the NIBP START/STAT/STOP key and allow the monitor to take at least four (4) readings. The systolic, diastolic and mean readings should not vary by more than $\pm 4\%$ or ± 4 mmHg (whichever is greater) from the calculated average. Each reading shall not vary more than 8 mmHg from the simulator setting.

Leave the monitor connected to the NIBP analyzer. Change the NIBP analyzer setting to the neonate configuration with a simulator setting of 80/50 (62) mmHg; Heart Rate 80 bpm. A neonatal dummy cuff must be used during this test.

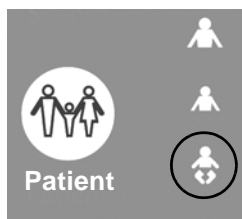

1. Set the monitor to *NEONATE* Mode by pressing the PATIENT key until the NEONATE icon illuminates.
2. Press the NIBP START/STAT/STOP key and allow the monitor to take at least four (4) readings. The systolic, diastolic and mean readings should not vary by more than $\pm 4\%$ or ± 4 mmHg (whichever is greater) from the calculated average. Each reading shall not vary more than 8 mmHg from the simulator setting.
3. If the monitor continues to fail verification contact the Criticare Technical Support Department.

NIBP Seal Test **EQUIPMENT REQUIRED**

- Digital manometer, calibrated (accuracy of $\pm 0.05\%$)
- Manual squeeze bulb with valve
- “Tee” connector

SETUP

1. Connect the manual squeeze bulb to the “tee” connector.
2. Connect the digital manometer to the “tee” connector.
3. Connect the “tee” connector to the NIBP connector on the monitor.

PROCEDURE

The 506N3 Series monitor has a simple test mode for checking the seal and pressure transducer. The instructions are as follows:

1. Press the POWER key while holding the DOWN arrow key.
2. The monitor begins its normal boot sequence but enters the Service Mode instead. The LCD shows the message *SERVICE DISPLAY*.
3. Press the DOWN arrow to scroll through the menu options to *TEST MENU*.
4. Press the DOWN arrow to scroll through the test menu options to *NIBP SEAL <-- OFF*.
5. Press the MENU key. The display should read *NIBP SEAL --> OFF*.
6. Press the DOWN arrow once to turn the test to *ON*.
7. Press the MENU key to start the test.

The monitor will then function as a plain pressure meter allowing the technician to manual test the pressure transducer with a manometer.

Pump up the manual squeeze bulb. Verify that the manometer readings agree with the monitor readings. The accuracy of the pressure transducer for static pressure measurements should be within ± 2 mmHg or $\pm 2\%$ of reading, whichever is greater. The current pressure will be displayed in the LCD window.

**SpO₂ Verification:
CSI DOX Only****NOTE:** This procedure is for models with the optional DOX SpO₂ Oximeter.

1. Disconnect the DOX SpO₂ sensor from the unit after power up.
2. Verify a red LED lights up the sensor signal symbol on the front of the membrane.
3. Using a SpO₂ finger sensor, verify heart rate and plethysmograph operation displayed on the LED's within 15 seconds. Verify no SpO₂ error messages appear (alarm violations may occur depending on individual readings and monitor set-up).
4. Verify the 10-segment green LED bar graph displays the relative strength of the pulse by lighting a proportional number of LED segments. Remove your finger from the sensor.
5. Verify *SPO2: SENSOR* message is displayed when the finger sensor is plugged in, but with no finger inserted in the sensor.
6. Verify *SPO2: HIGH AMBIENT* message appears by introducing a higher than normal amount of ambient light on the SpO₂ sensor detector.
7. Using an optical load to simulate a small signal (such as a foam packing peanut), verify that the message *SPO2: LOST* appears on the display.
8. Verify *SPO2: NO SENSOR* message is displayed when there is nothing connected to the SpO₂ connector.

**SpO₂ Verification:
Nellcor Only****NOTE:** This procedure is for models with the optional Nellcor SpO₂ Oximeter.

1. Disconnect the OxiMax SpO₂ sensor from the unit after power up.
2. Verify a red LED lights up the sensor symbol on the front membrane.
3. Using a Nellcor SpO₂ finger sensor, verify heart rate and plethysmograph operation displayed on the LED's within 15 seconds. Verify no SpO₂ error messages appear (alarm violations may occur depending on individual readings and monitor set-up).
4. Verify the 10-segment green LED bar graph displays the relative strength of the pulse by lighting a proportional number of LED segments.
5. Verify *SPO2: PULSE LOST* message appears after the unit has taken a reading, then removing your finger from the sensor.

6. Remove the finger sensor and reconnect to the connector on the monitor. Verify *SPO2: SENSOR* message is displayed when the finger sensor is plugged in, but with no finger inserted in the sensor.
7. Remove the sensor from the monitor. Verify *SPO2: NO SENSOR* message is displayed when there is nothing connected to the SpO₂ connector.

Temperature Verification

NOTE: This procedure is for models with the optional temperature model (both FasTemp and TurboTemp).

1. Verify the *TEMP: NO PROBE* message displays when there is no temperature probe connected to the side panel.
2. *For FasTemp models*, add the blue chamber with probe. Probe should be inserted into the blue chamber.

For TurboTemp models, plug temperature probe into connector. Probe should be inserted into probe well.

3. Select the ORAL version, if not already set for, by pressing the ORAL/AXIAL button on the membrane switch.

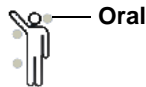

4. Remove the probe. The LED should flash by the head of the human icon.

5. Place the probe into a probe cover and insert into mouth to verify a temperature reading appears. Reinsert the probe into the chamber/well.

6. Select the AXIAL version by pressing the ORAL/AXIAL button on the membrane switch.

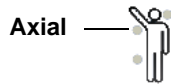

7. Remove the probe. The LED should flash by the upraised arm of the human icon.

8. Place the probe under an armpit to verify a temperature reading appears.

9. Remove the probe cover and reinsert the probe into the chamber/well.

10. *For FasTemp models*, remove the blue box. The message *TEMP: NO PROBE* should appear.

For TurboTemp models, Disconnect temperature probe from the connector. The message *TEMP: NO PROBE* should appear.

11. *For FasTemp models*, connect the simulator box to the guide that just contains the cal tool probe. Insert the temperature probe to activate the switch, then remove. A simulated temperature of 37.0° C ±0.1 or 98.6° F ±0.2 should appear. Remove the Simulator box.

For TurboTemp models, connect an Alaris No. TE 1811 TurboTemp probe simulator to the probe connector on the unit. Ensure *Axial* is selected on the unit. Set the simulator to 98.6° F. Withdraw the temperature probe from the well. A simulated temperature of 37.0° C ±0.1 or 98.6° F ±0.2 should appear. Remove the probe simulator.

12. *For FasTemp models*, connect a red rectal chamber and probe to the guide with the probe attached.

For TurboTemp models, connect a red rectal temperature probe to the connector.



13.Remove the probe. The LED should flash by the legs on the human icon.

14.Place the probe into a probe cover and place the probe under an armpit to verify a temperature reading appears. Reinsert the probe into the chamber/well.

Optional: Other temperatures and functions may be verified with the Alaris TurboTemp Probe Simulator. (TurboTemp models only.)

| <u>Simulator Setting</u> | Thermometer Reading |
|---------------------------------|----------------------------|
| 80.2 | 80.2 ±0.2 F (26.7 ±0.1 C) |
| 98.0 | 98.0 ±0.2 F (36.7 ±0.1 C) |
| 98.6 | 98.6 ±0.2 F (37.0 ±0.1 C) |
| 102.0 | 102.0 ±0.2 F (38.9 ±0.1 C) |
| 107.8 | 107.8 ±0.2 F (42.1 ±0.1 C) |
| B.P. | 106.0 ±0.2 F (41.1 ±0.1 C) |

Verify *TEMP: BAD PROBE* message displays when the Broken Probe button is pressed on IVAC simulator when the dial is set for B.P.

Functional and Safety Testing Checklist

Use the checklist on the following pages to record the successful completion of the annual safety tests and verification.

Functional and Safety Testing Checklist (Page 1 of 3)

Copy this checklist as needed to record results.

Model _____

Unit serial number _____

Software Rev. _____

Tested by _____

Date _____

Electrical Safety Tests

Hi-Pot Tests

| | PASS | FAIL | N/A | |
|--|-------------|-------------|------------|-----------------------------------|
| Hi-Pot Hot/Neutral to Ground @ 2512VDC | _____ | _____ | | |
| Hi-Pot Hot/Neutral to Metal Case @ 2512VDC | _____ | _____ | | |
| Hi-Pot Hot/Neutral to DOX SpO ₂ Gnd @ 4242VDC | _____ | _____ | _____ | (DOX SpO ₂) |
| Hi-Pot DOX SpO ₂ to DB-9 shell @ 2121VDC | _____ | _____ | _____ | (DOX SpO ₂) |
| Hi-Pot Hot/Neutral to Nellcor SpO ₂ @ 4242VDC | _____ | _____ | _____ | (Nellcor SpO ₂) |
| Hi-Pot Nellcor SpO ₂ to DB-9 shell @ 2121VDC | _____ | _____ | _____ | (Nellcor SpO ₂) |
| Hi-Pot Hot/Neutral to FasTemp cable @ 4242VDC | _____ | _____ | _____ | (Temperature) |
| Hi-Pot FasTemp cable to DB-9 shell @ 2121VDC | _____ | _____ | _____ | (Temperature) |
| Hi-Pot DOX SpO ₂ to FasTemp cable 2121VDC | _____ | _____ | _____ | (DOX SpO ₂ , Temp) |
| Hi-Pot Nellcor SpO ₂ to FasTemp cable @ 2121VDC | _____ | _____ | _____ | (Nellcor SpO ₂ , Temp) |
| Hi-Pot Hot/Neutral to TurboTemp cable @ 4242VDC | _____ | _____ | _____ | (Temperature) |
| Hi-Pot TurboTemp cable to DB-9 shell @ 2121VDC | _____ | _____ | _____ | (Temperature) |
| Hi-Pot DOX SpO ₂ to TurboTemp cable 2121VDC | _____ | _____ | _____ | (DOX SpO ₂ , Temp) |
| Hi-Pot Nellcor SpO ₂ to TurboTemp cable @ 2121VDC | _____ | _____ | _____ | (Nellcor SpO ₂ , Temp) |

Leakage Tests

| | PASS | FAIL | N/A |
|---|-------------|-------------|------------|
| Leakage GND CONDUCTOR Normal Polarity (<100uA) | _____ uA | _____ uA | |
| Leakage GND CONDUCTOR Normal Reverse (<100uA) | _____ uA | _____ uA | |
| Leakage Open GND and Open Neutral Normal Polarity (<500uA) | _____ uA | _____ uA | |
| Leakage Open GND and Open Neutral Reverse Polarity (<500uA) | _____ uA | _____ uA | |
| Leakage Case Normal Polarity (<100uA) | _____ uA | _____ uA | |
| Leakage Case Reverse Polarity (<100uA) | _____ uA | _____ uA | |
| Leakage Case Normal Polarity Open Ground (<500uA) | _____ uA | _____ uA | |
| Leakage Case Reverse Polarity Open Ground (<500uA) | _____ uA | _____ uA | |
| DOX SpO ₂ LEAKAGE Normal Polarity (<10uA) | _____ uA | _____ uA | _____ |
| DOX SpO ₂ LEAKAGE Normal Polarity Open GND (<50uA) | _____ uA | _____ uA | _____ |
| Nellcor SpO ₂ LEAKAGE Normal Polarity (<10uA) | _____ uA | _____ uA | _____ |
| Nellcor SpO ₂ LEAKAGE Normal Polarity Open GND (<50uA) | _____ uA | _____ uA | _____ |
| FasTemp LEAKAGE Normal Polarity (<10uA) | _____ uA | _____ uA | _____ |
| FasTemp LEAKAGE Normal Polarity Open GND (<50uA) | _____ uA | _____ uA | _____ |
| FasTemp LEAKAGE Normal Polarity (<10uA) | _____ uA | _____ uA | _____ |
| FasTemp LEAKAGE Normal Polarity Open GND (<50uA) | _____ uA | _____ uA | _____ |
| TurboTemp LEAKAGE Normal Polarity (<10uA) | _____ uA | _____ uA | _____ |
| TurboTemp LEAKAGE Normal Polarity Open GND (<50uA) | _____ uA | _____ uA | _____ |
| TurboTemp LEAKAGE Normal Polarity (<10uA) | _____ uA | _____ uA | _____ |
| TurboTemp LEAKAGE Normal Polarity Open GND (<50uA) | _____ uA | _____ uA | _____ |
| Isolation test DOX SpO ₂ (<50uA) | _____ uA | _____ uA | _____ |
| Isolation test Nellcor SpO ₂ (<50uA) | _____ uA | _____ uA | _____ |
| Isolation test FasTemp (<50uA) | _____ uA | _____ uA | _____ |
| Isolation test TurboTemp (<50uA) | _____ uA | _____ uA | _____ |

Functional and Safety Testing Checklist (Page 2 of 3)

| | PASS | FAIL | N/A |
|--|-------|-------|-------|
| Functional Tests | | | |
| Alarm Functions | | | |
| Verify Pulse volume operation from 0 to 10 | _____ | _____ | |
| Verify Alarm volume operation from 0 to 10 | _____ | _____ | |
| Verify 2 minute Alarm Silence function | _____ | _____ | |
| Verify permanent Alarm Silence function | _____ | _____ | |
| Display Functions | | | |
| Verify Green Charge LED w/AC power connected | _____ | _____ | |
| Powerup Function | | | |
| Verify unit powers up with AC plug in | _____ | _____ | |
| Verify unit powers up on battery | _____ | _____ | |
| NIBP Function | | | |
| Simulator set to Adult mode @120/80 – 1 min cycle (Each reading does not vary by more than ±4% or ±4mmHg (whichever is greater) from the calculated average.) | | | |
| _____/_____, _____/_____, _____/_____, _____/_____ | | | |
| Average: ____/____ | _____ | _____ | |
| Simulator set to Neonate mode @80/50 – Stat mode (Each reading does not vary by more than ±4% or ±4mmHg (whichever is greater) from the calculated average.) | | | |
| _____/_____, _____/_____, _____/_____, _____/_____ | | | |
| Average: ____/____ | _____ | _____ | |
| Seal Test | _____ | _____ | |
| SpO₂ Functions | | | |
| Verify SPO2: NO SENSOR condition (DOX, NELLCOR) | _____ | _____ | |
| Verify SPO2: SENSOR condition (DOX, NELLCOR) | _____ | _____ | |
| Verify SPO2: HIGH AMBIENT condition (DOX only) | _____ | _____ | _____ |
| Take SPO2 & HR readings (DOX, NELLCOR) | _____ | _____ | |
| Verify LED Bargraph (DOX, NELLCOR) | _____ | _____ | |
| Sensor symbol operation (DOX, NELLCOR) | _____ | _____ | |
| Verify SPO2: LOST condition (DOX only) | _____ | _____ | _____ |
| Verify SPO2: PULSE LOST condition (NELLCOR only) | _____ | _____ | _____ |
| FasTemp Temperature Functions | | | |
| Verify TEMP: NO PROBE condition | _____ | _____ | |
| Verify Temperature readings Blue box Oral | _____ | _____ | |
| Verify Temperature readings Blue box Axial | _____ | _____ | |
| Verify Temperature Simulator readings 37.0 C or 98.6 F | _____ | _____ | |
| Verify Temperature Readings Red box Rectal | _____ | _____ | |
| TurboTemp Temperature Functions | | | |
| Verify TEMP: NO PROBE appears | _____ | _____ | |
| Connect the Alaris TE 1811 probe and LED blinking | _____ | _____ | |
| Verify 98 degrees at the Start position | _____ | _____ | |
| Verify that the temp reads 80.2 F ±0.2 or 26.8 C ±0.1 | _____ | _____ | |
| Verify that the temp reads 98.0 F ±0.2 or 36.7 C ±0.1 | _____ | _____ | |
| Verify that the temp reads 98.6 F ±0.2 or 37.0 C ±0.1 | _____ | _____ | |
| Verify that the temp reads 102.0 F ±0.2 or 38.9 C ±0.1 | _____ | _____ | |
| Verify that TEMP: INVALID appears @ 107.8 | _____ | _____ | |
| Verify that BP reads 106.0 degrees or ---.-F | _____ | _____ | |
| Verify that TEMP: BAD PROBE appears when BP is pressed | _____ | _____ | |
| Verify that the rectal LED illuminates when probe is inserted and withdrawn | _____ | _____ | |

Functional and Safety Testing Checklist (Page 3 of 3)

| | PASS | FAIL | N/A |
|---|-------|-------|-----|
| Printer Function | | | |
| Verify paper auto feeds into printer | _____ | _____ | |
| Verify that after pressing PRINT, information is contained on paper | _____ | _____ | |
| Verify PAPER FEED button and paper advances | _____ | _____ | |
| Verify that Trends exits in memory | _____ | _____ | |
| Set <i>Time, Date</i> to correct time | _____ | _____ | |

CERTIFICATION THAT THE UNIT IS CALIBRATED AND FUNCTIONING PROPERLY.

NAME _____ DATE _____

COMMENTS _____

Section 6 —Service Testing & Calibration

Monitor Testing

If the monitor fails any portion of these tests contact the Criticare Service Department for additional information. See “Functional and Safety Testing” in Section 5 for functional and electrical safety tests. Monitoring module verifications are also located in “Service Checks” in Section 5.

Service Checks If the monitor shows any signs of physical damage return it to Criticare for repair.

WARNING

- If the unit fails any tests, contact Criticare. Do not use the monitor for patient monitoring until you fix the problem.
- No user-serviceable parts exist inside the monitor. Do not remove the cover. Refer all servicing to a qualified technician.

Field Service Testing

WARNING



- Service testing procedures require working with exposed electrical circuits and only experienced electrical or biomedical technicians should attempt these procedures.
- Any time a monitor is altered through repair or hardware adjustment, you should fully test it before use.



CAUTION

- Always follow ESD precautions when you perform any of the procedures discussed in this section.
- The manufacturer recommends that a serviced monitor be allowed to run for 24 hours before you place the monitor back into operation.
- Modules and PCBs that you have repaired may require more extensive testing than what is described in this manual.

The following tests are designated for monitors that require service repairs. Opening the monitor may void your warranty, so it is important to contact Criticare customer service before you attempt any repair.

The pre-assembly testing of printed circuit boards (PCBs) is not covered in this manual. Disassembly of surface mounted components on PCBs is not recommended. Tests provided here are only for the identification of damaged or degraded PCBs.

Any time you open a monitor's case you should perform the electrical safety tests before you return the monitor to operation. If you serviced the monitor you should also perform the associated functional tests.

Additional tests that are specific to modules and assemblies you should perform when you service, adjust, calibrate, or otherwise disassemble any assemblies. See the following table.

| Field Service Testing | Withstanding Voltage (Hi-Pot) | Electrical Leakage | Functional Testing | SpO2 Verification | NIBP Verification | Temperature Verification | Communication Testing | SpO2 Performance Testing | NIBP Module Calibration | Power Supply Calibration | Communication Board Calibration |
|------------------------------|-------------------------------|--------------------|--------------------|-------------------|-------------------|--------------------------|-----------------------|--------------------------|-------------------------|--------------------------|---------------------------------|
| | | | | | | | | | | | |
| No Fault (case opened) | ✓ | ● | ✓ | | | | | | | | |
| Battery | | | ✓ | | | | | | | | |
| NIBP Module | ✓ | ● | ✓ | | ● | | | | ● | | |
| Temperature Board | ✓ | ● | ✓ | | | ● | | | | | |
| DOX SpO2 Board | ✓ | ● | ✓ | ● | | | | ● | | | |
| Nellcor SpO2 Module | ✓ | ● | ✓ | ● | | | | ● | | | |
| Nellcor SpO2 Carrier Board | ✓ | ● | ✓ | ● | | | | ● | | | |
| Main Board | ● | ● | ● | ✓ | ✓ | ✓ | ✓ | ● | | ● | |
| Communications Board | ● | ● | ✓ | | | | | | | | ● |
| EPROM (Firmware update) | ● | ● | ● | | ✓ | ✓ | ✓ | | | | |
| Display/LCD Board | ● | ● | ● | | ✓ | ✓ | ✓ | | | | |
| Keypad | ● | ● | ● | | ✓ | ✓ | ✓ | | | | |
| Front Enclosure Disassembled | ● | ● | ● | | ✓ | ✓ | ✓ | | | | |
| Printer | ✓ | ● | ✓ | | | | ● | | | | |
| Monitor Dropped | ✓ | ✓ | ✓ | ✓ | ✓ | ✓ | ✓ | | | | |
| Software Download | | | ● | ✓ | ✓ | ✓ | | | | | |
| Annual Safety Test | ● | ● | ✓ | ✓ | ✓ | ✓ | | | | | |

Equipment and Tools The following procedures assume that the technician has available an ESD safe workbench, a set of electronic hand tools, and a digital multimeter with a 10-amp setting. Servicing of the NIBP module requires a calibration work station. At the beginning of each test special equipment may be listed. A variety of customized cables, clips, and test fixtures may also be needed to complete all the tests. Contact Criticare Service for additional information.

Communication Testing

Equipment Required

- Windows-compatible computer with DB-9 serial port

NOTE: If your computer uses USB ports instead of a serial port a USB/Serial converter with software is needed to complete this procedure. Install the converter and software on the computer as directed by the converter manufacturer. The following adapters are recommended.

- IOmega USB to Serial/PDA Converter CableGUC232A
- Keyspan USB Serial AdapterUSA-19HS
- Serial download cable (pn 87016B002)
- A common computer terminal program

Pinout Chart

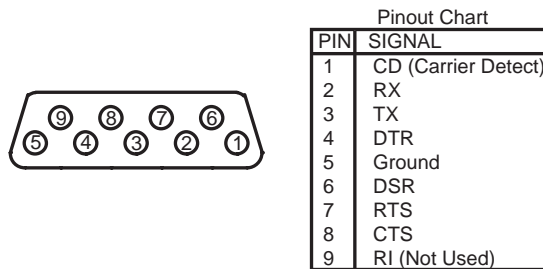

Figure 6-1: Pinout Chart

Procedure

1. Set the print device to *SERIAL* in the *PRINTER SETUP* menu. Printing is then be routed to the communications port instead of the internal printer.
2. Set the serial format to *TEXT* in the *CONFIGURATION* Menu to simulate the tabular printout of the internal printer.
3. Connect the COM port to the serial port on the computer or the USB port (with adapter) on the laptop.
4. Start Hyper Terminal from the Accessories|Communication menu on the PC. Settings: 19200 bps, 8-N-1, or Auto Detect.

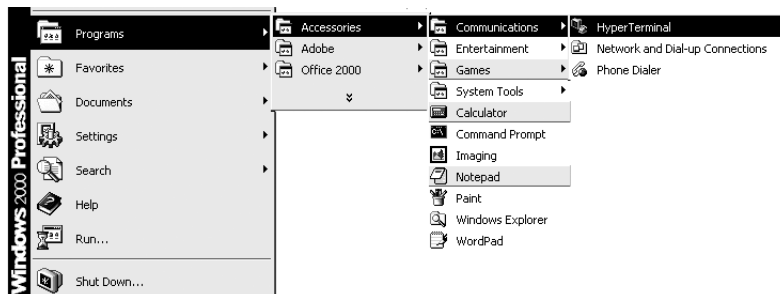

Figure 6-2: PC HyperTerminal

5. Press the PRINT key on the monitor to initiate a print of data.
6. Ensure data prints to the computer.

DOX SpO₂ Performance Testing

This test requires a SmartSat Pulse Oximetry Analyzer, Model SS-100A. The SmartSat is a programmable simulator and probe analyzer. The SmartSat is the recommended device for testing the DOX SpO₂ module. The SmartSat, model SS-100A, is available from Clinical Dynamics Corp. of Wallingford, CT.

The SmartSat comes standard with a Lemo style connection. The Cat. No. 913A adapter that converts Lemo to DB-9 style SpO₂ connections is needed for the 506N3 Series monitor. The analyzer also has a custom port designed for testing DOX™ SpO₂ sensors.

Programming the SmartSat Analyzer

The SmartSat can be used for spot checking SpO₂ values using the manual settings. The manufacturer recommends using a timed and programmed sequence to ensure that there is optimal performance.

| Auto Seq: Model 506N3 | | | Oximeter | DOX |
|-----------------------|------|--------|------------|--------|
| Level | SPO2 | Limits | Heart rate | Limits |

Test Procedure

1. Verify the SpO₂ module as described in “SpO₂ Verification: CSI DOX Only” in Section 5.
2. Attach the monitor to the SmartSat.
3. Start the SmartSat programmed sequence: *SmartSat Auto Sequence*. Verify that the monitor’s reported SpO₂ values are within the limits specified.

| Level | Saturation (%) | Limits (%) | Heart Rate (bpm) | Limits (bpm) |
|-------|----------------|------------|------------------|--------------|
| 1 | 98 | 97 - 99 | 40 | 39-41 |
| 2 | 96 | 94 - 98 | 60 | 59-61 |
| 3 | 90 | 88 - 92 | 80 | 79-81 |
| 4 | 78 | 76 - 80 | 100 | 99-101 |
| 5 | 61 | 58 - 64 | 120 | 119-121 |
| 6 | 52 | 49 - 55 | 180 | 179-181 |
| 7 | 40 | 37 - 43 | 300 | 297-303 |

4. Even if the monitor fails only one level, rerun the sequence after 30 seconds. Only if the monitor is successful the second time, do you pass the monitor.
5. If the monitor fails again, contact the Criticare Service Department.

Nellcor SpO₂ Performance Testing

This test requires a SmartSat Pulse Oximetry Analyzer, Model SS-100A. The SmartSat is a programmable simulator and probe analyzer. The SmartSat is the recommended device for testing the DOX SpO₂ module. The SmartSat, model SS-100A, is available from Clinical Dynamics Corp. of Wallingford, CT. The SmartSat should have software version 3.11.

The SmartSat comes standard with a Lemo style connection. The Cat. No. 913A adapter that converts Lemo to DB-9 style SpO₂ connections is needed for the 506N3 Series monitor. The analyzer also has a custom port designed for testing Nellcor™ SpO₂ sensors.

- SmartSat SS-100A or equivalent pulse oximetry analyzer
- CAT. 913A cable converter (For units utilizing DB-9 sensors)
- Nellcor adapter cable to attach from Smartsat (CAT 939XS)
- Nellcor Adapter cable to SmartSat

Programming the SmartSat Analyzer

The SmartSat can be used for spot checking SpO₂ values using the manual settings. The manufacturer recommends using a timed and programmed sequence to ensure that there is optimal performance.

| Auto Seq: Nell OxiMAX | | | Oximeter | N OxiMAX |
|-----------------------|------|--------|------------|----------|
| Level | SPO2 | Limits | Heart rate | Limits |

Test Procedure

1. Verify the SpO₂ module as described in “SpO₂ Verification: Nellcor Only” in Section 5.
2. Attach the monitor to the SmartSat.
3. Start the SmartSat programmed sequence: *SmartSat Auto Sequence*. Verify that the monitor’s reported SpO₂ values are within the limits specified.

| Level | Saturation (%) | Limits (%) | Heart Rate (bpm) | Limits (bpm) |
|-------|----------------|------------|------------------|--------------|
| 1 | 98% | 97 - 99% | 40 bpm | 39-41 bpm |
| 2 | 78 | 76 - 80 | 120 | 119-121 |
| 3 | 52 | 49 - 55 | 300 | 297-303 |

4. Even if the monitor fails only one level, rerun the sequence after 30 seconds. Only if the monitor is successful the second time, do you pass the monitor.
5. If the monitor fails again, contact the Criticare Service Department.

NIBP Calibration

The manufacturer recommends that NIBP calibration be performed only at authorized service facilities. The NIBP calibration procedures require specialized equipment (Cat. No. 454-G Calibration Kit) necessary for proper calibration testing.

Equipment Required

- Windows-compatible computer with DB-9 serial port
- USB ports: a USB/Serial converter with software is needed to complete this procedure. Install the converter and software on the computer as directed by the converter manufacturer.
- Digital manometer, calibrated (accuracy of $\pm 0.05\%$)
- Plastic tuning tool
- ESD Protected Work Bench
- Calibration Kit (Cat. No. 454-G), includes:
 - Serial null modem cable DB9F-DB9F 6-foot null modem cable (pn 87016B002)
 - Calibration fixture with 700cc reservoir and tee connector
 - Service program software CD-ROM (pn 97082A003, revision 2 or higher)

Installing the PC Service Program

The NIBP Service Program is provided on a self-installing CD-ROM disk. If the CD-ROM does not run automatically you may need to click on the CD-ROM drive icon.

Run the auto-installation disk. The program NIBPSvc.exe will be loaded into the Program Files directory. The new folders CSI\Tools will be created. A launch icon will also be placed on the desktop of the computer.

Configuring the Ports

The Service Program is designed to operate using a serial COM1, COM3 or COM4 port. If your computer uses USB ports instead of a serial port an adapter will be required. The following adapters are recommended.

- IOmega USB to Serial/PDA Converter CableGUC232A
- Keyspan USB Serial Adapter.....USA-19HS

If COM1, COM3 or COM4 is not available as a free port, the ports will need to be reconfigured in the computer's device manager. Go to *Control Panel\System\Hardware* and select *Device Manager*. Select *Ports* and reassign the alternate port or the USB to Serial Adapter to COM1, COM3 or COM4. *For laptops using a USB adapter, select COM 4 or an alternate COM port as necessary.*

Setup

1. Turn off the power and disconnect the AC (Mains) power.
2. Place the monitor on a ESD protected workbench. Observe all ESD protection procedures as described in “Electrostatic Discharge Protection” in Section 7.
3. Connect the download cable to the DB-9 serial connection of the monitor’s front bezel. Connect the other end to the DB-9 serial port of the computer.
4. Open the service tool on the computer. Select *Start > Programs > CSI NIBP Service > NIBPSvc* (or click on the shortcut on the PC desktop).
5. Select *COM1* for the port.



For laptops using a USB adapter, select COM 4 or an alternate COM port as necessary.

6. Select *506N3 NIBP MODULE* in the drop-down menu box.



Figure 6-3: Select the COM Port and Model

7. Plug the monitor back to the AC (Mains) source.
8. Power up the unit while pressing the NIBP START/STAT/STOP key.
9. On the display of the unit, verify that the message *CHECKING FOR NIBP TOOLS....* appears.
10. Select the *Connection* from the drop-down menu. Select *Open in Service Mode*.

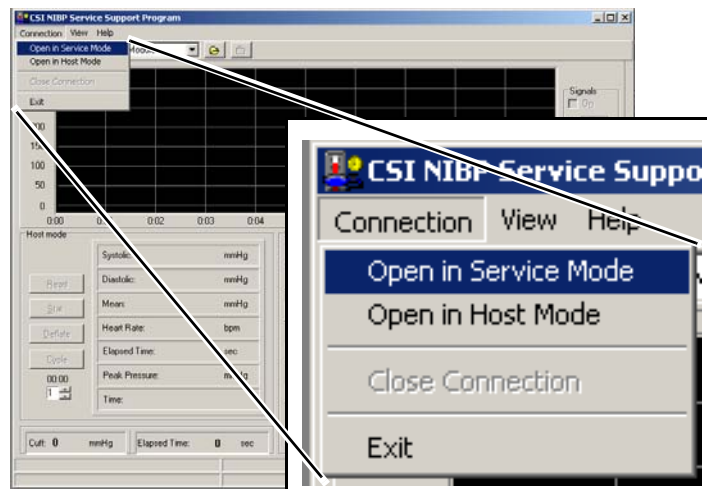

Figure 6-4: Select Open in Service Mode

11. If communication has been established, the following screen should appear. When this message appears, communication with the PC is established.

| | | |
|-------------------------|---------------------------|--------------------------------------|
| 506N3 NIBP Module | 26 Watchdog circuit fired | 04 Cuff pressure over limit for mode |
| 10 Host - NIBP disabled | 00 OK | 00 OK |

Figure 6-5: Communication Established

Calibrate 1. Select *Calibrate* from the service tool screen on the PC.

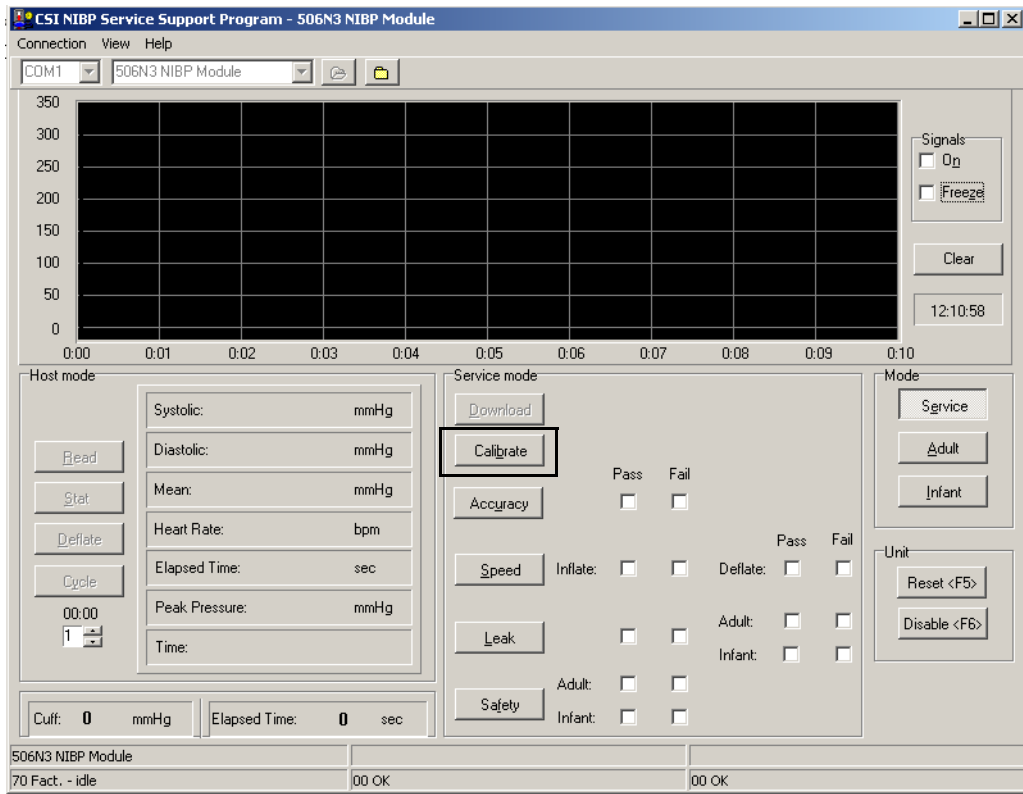

Figure 6-6: Select *Calibrate*

2. A box appears as shown. Verify that the pressure at the cuff is “0mmHg” ±2mmHg. If not, adjust R1 for 0.122 @ TP 10.

NOTE: Adjustment is only necessary for older NIBP Boards (pn 91325A002). NIBP Boards (pn 91325A003 and later) are self-calibrated to “0.”

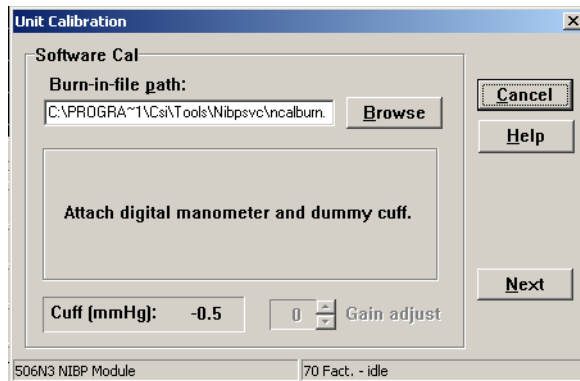

Figure 6-7: Verify Cuff Pressure

- Click *Next* and verify that the pressure at the cuff is “0mmHg” \pm 2mmHg.

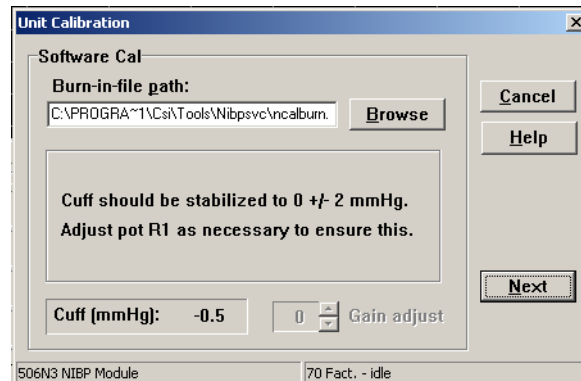

Figure 6-8: Verify Cuff Pressure

- Connect the fitting from the manometer onto the NIBP fitting on the unit. Click *Next* again. The pump should inflate to 250mmHG and then settle. Use the *UP* or *DOWN* buttons to adjust the gain to match the manometer pressure with the cuff pressure.
- When Manometer and cuff match, select *Finish*.

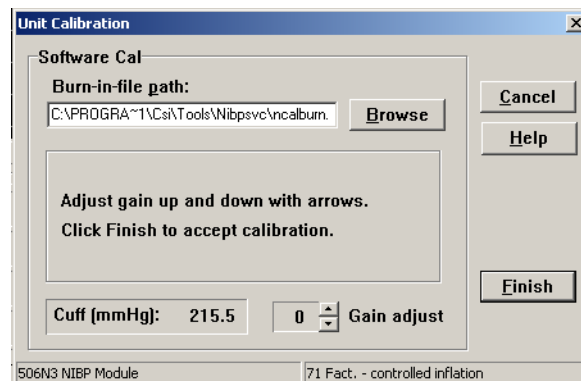

Figure 6-9: Finish Calibration

- The cal information is stored.

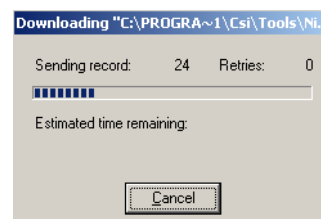

Figure 6-10: Storing Data

7. A *Positive Confirmation* message should appear. Select *Done*.

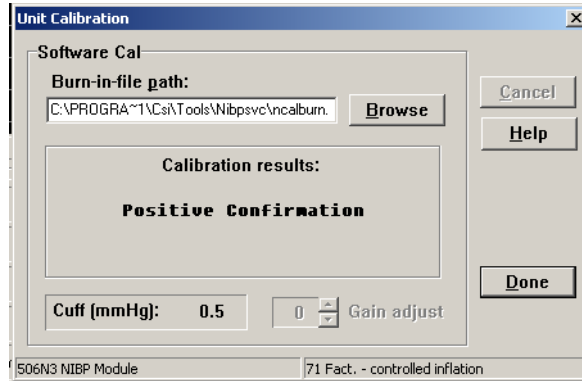

Figure 6-11: Positive Confirmation Message

If a confirmation fails, then power cycle the monitor and try re-calibrating the board again.

Safety Test

1. Using the mouse, click on the *Safety* test button.

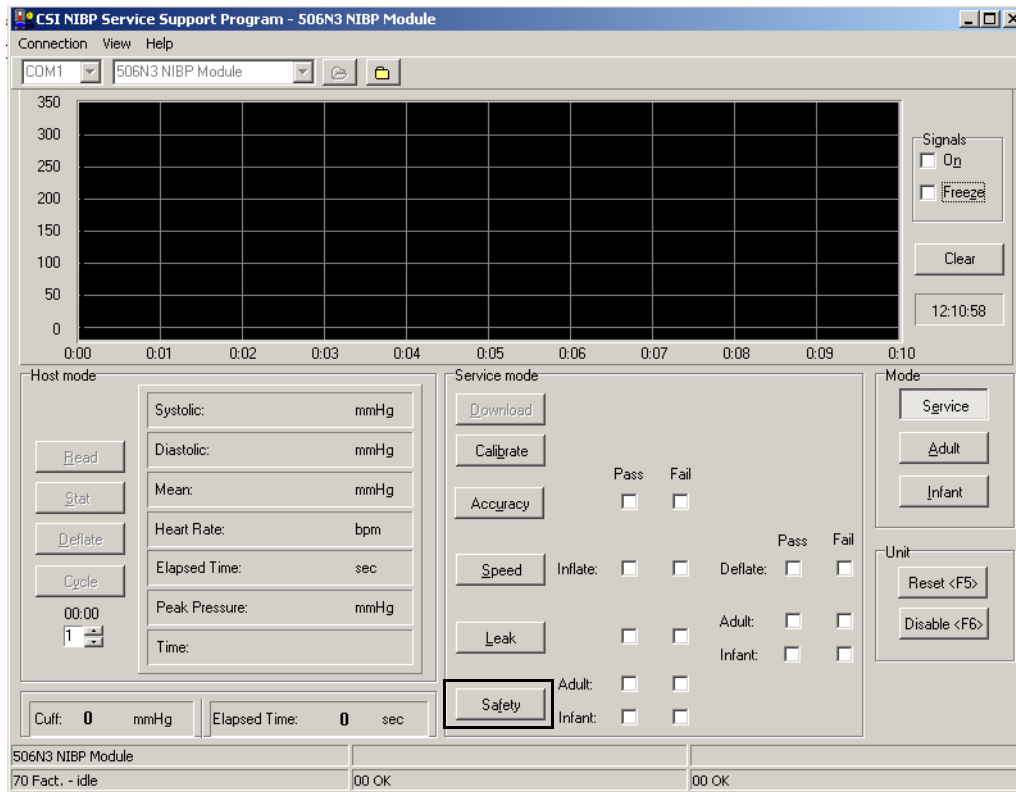

Figure 6-12: Select Safety

2. A *High Pressure Safety Test* window opens. Click on *Start*.

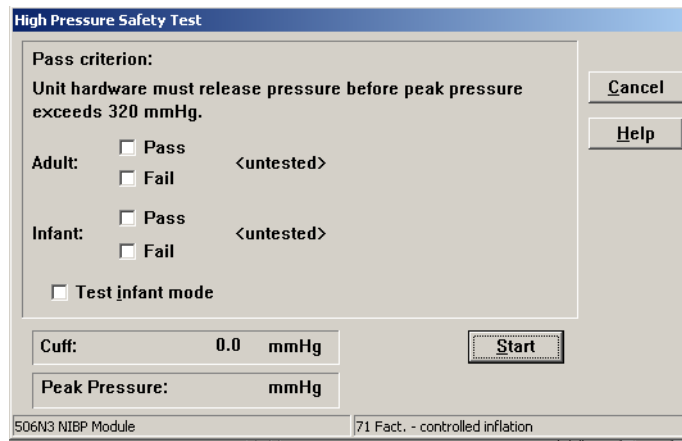

Figure 6-13: High Pressure Safety Test window

- The cuff pressure should increase until approximately 300-315 mmHg. Verify that the *Pass* box for *Adult* contains a checkmark.

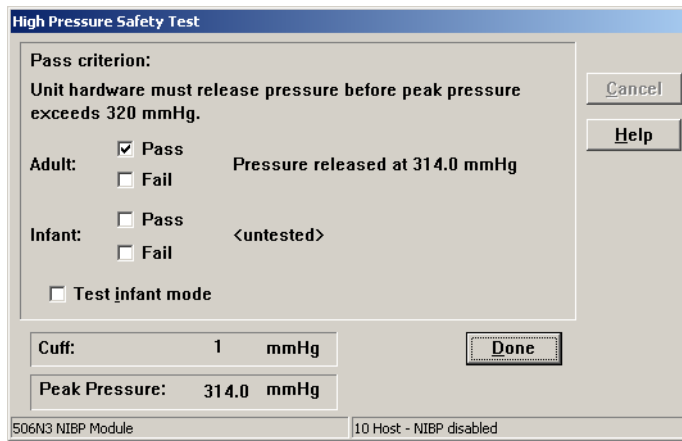

Figure 6-14: Adult Test Pass

- Click on the *Test Infant Mode*. A checkmark should appear in the box before it. Click *Start*.

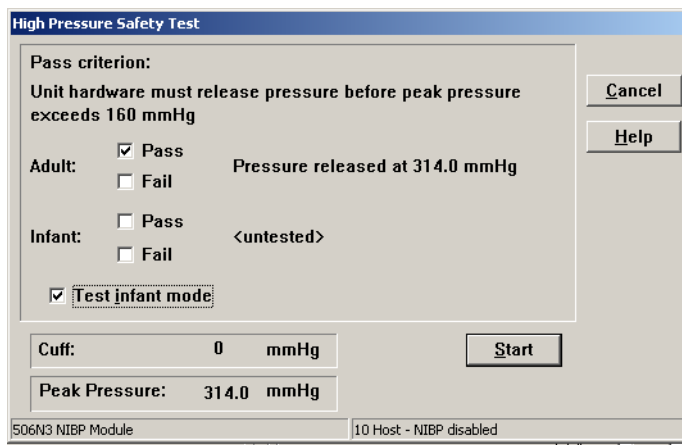

Figure 6-15: Test Infant Mode

- Verify that the *Pass* box in the *Infant* field contains a checkmark.

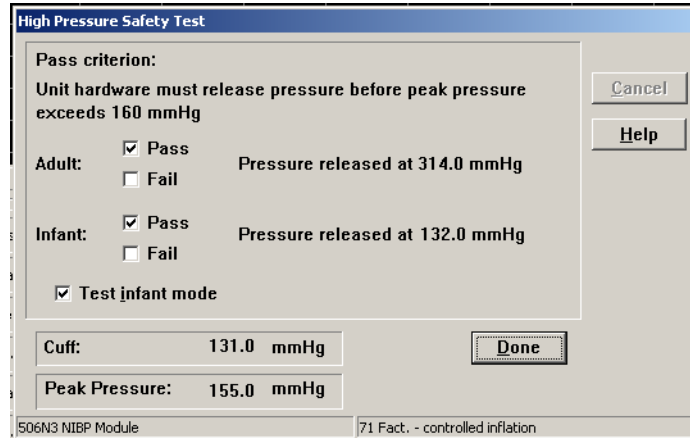

Figure 6-16: Test Infant Mode Pass

- Click *Done* if a checkmark appears in the *Pass* box. The main screen displays checkmarks indicating a *Pass* of the *Safety* tests.

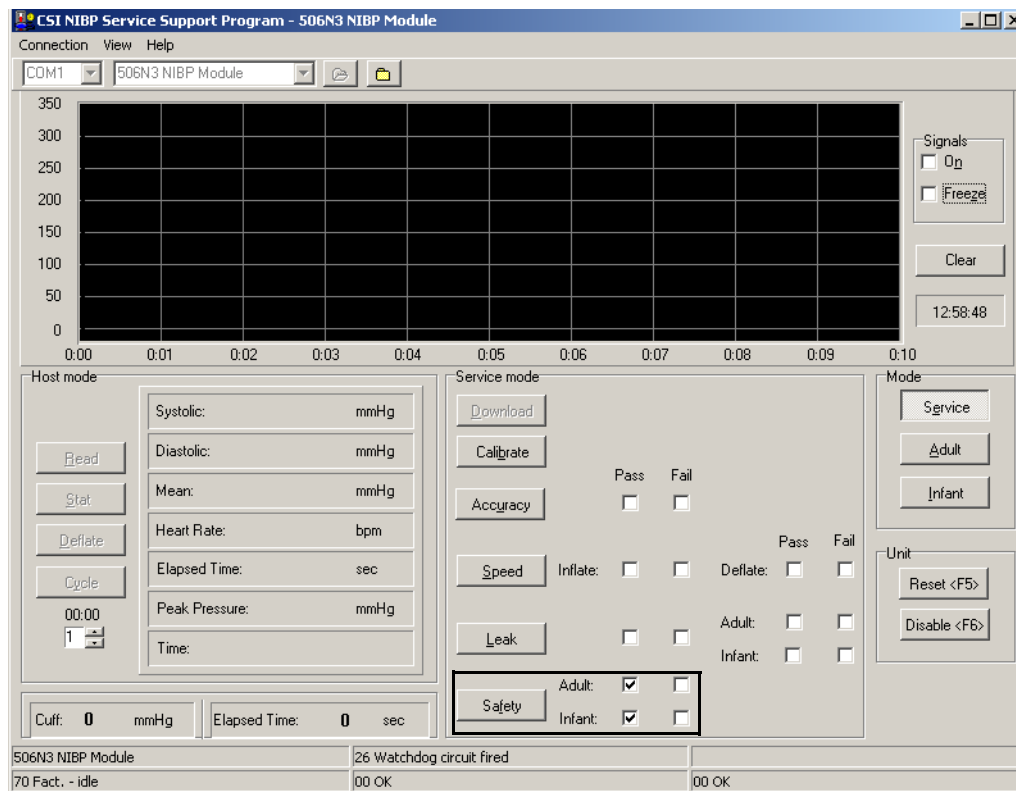

Figure 6-17: Safety Test Pass

Speed Test 1. Click on *Speed*.

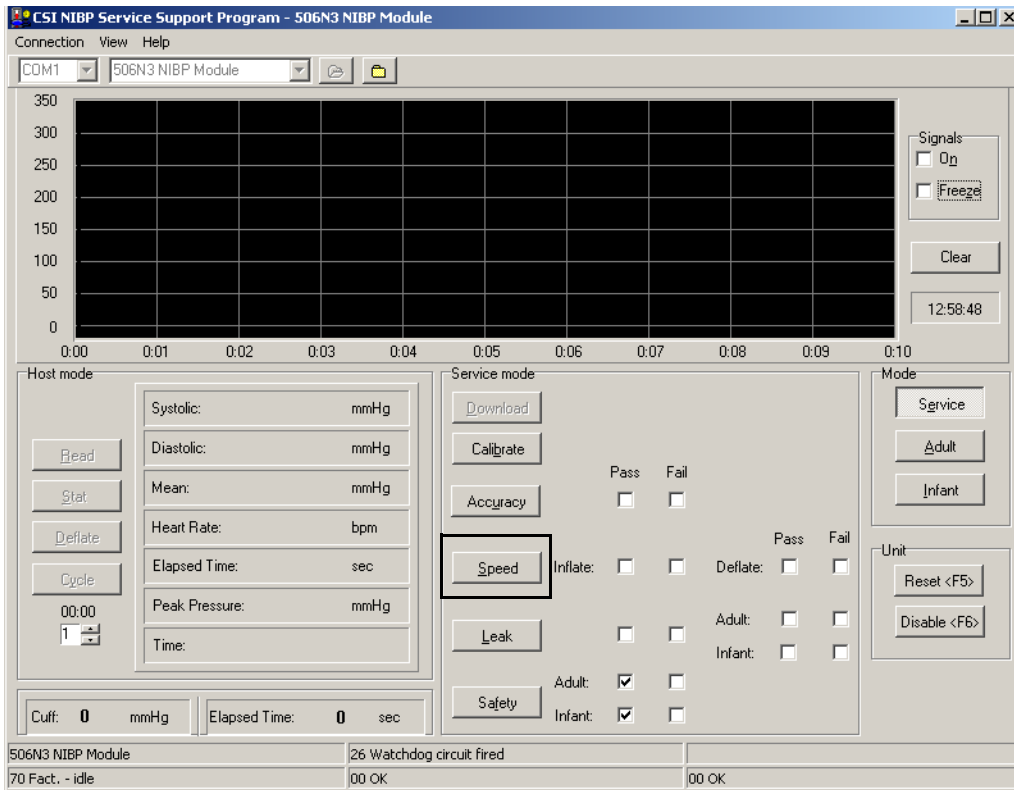

Figure 6-18: Select Speed

2. A *Factory Speed Test* window opens. Click on *Start*.

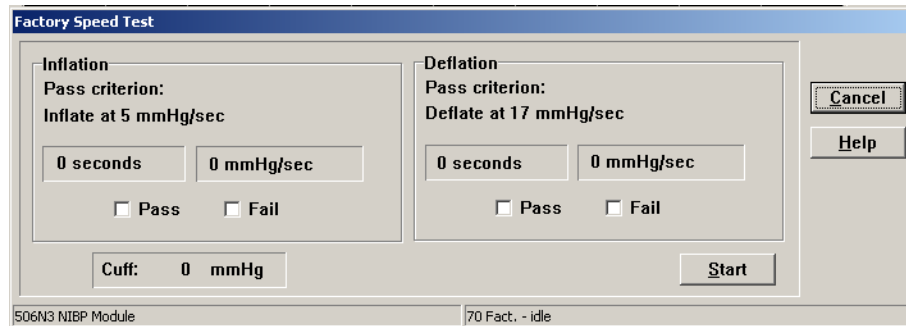

Figure 6-19: Factory Speed Test Window

- Verify that the *Inflation* and *Deflation* indicates a *Pass* with checkmarks in the boxes.

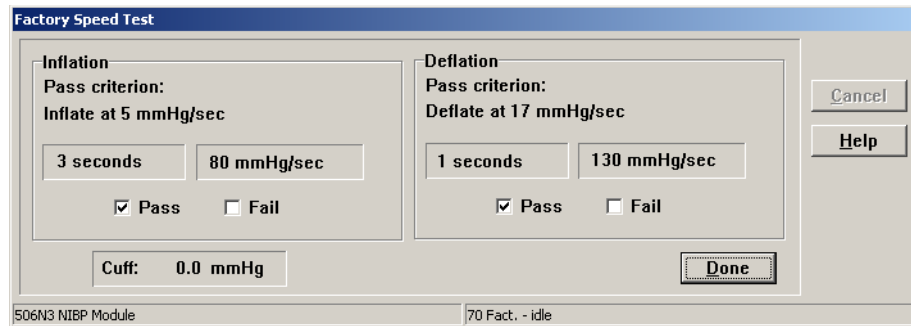

Figure 6-20: Factory Speed Test Pass

- If each *Pass* box has a checkmark, click on the *Done* button.
- The main screen displays checkmarks indicating a *Pass* of the *Speed* tests.

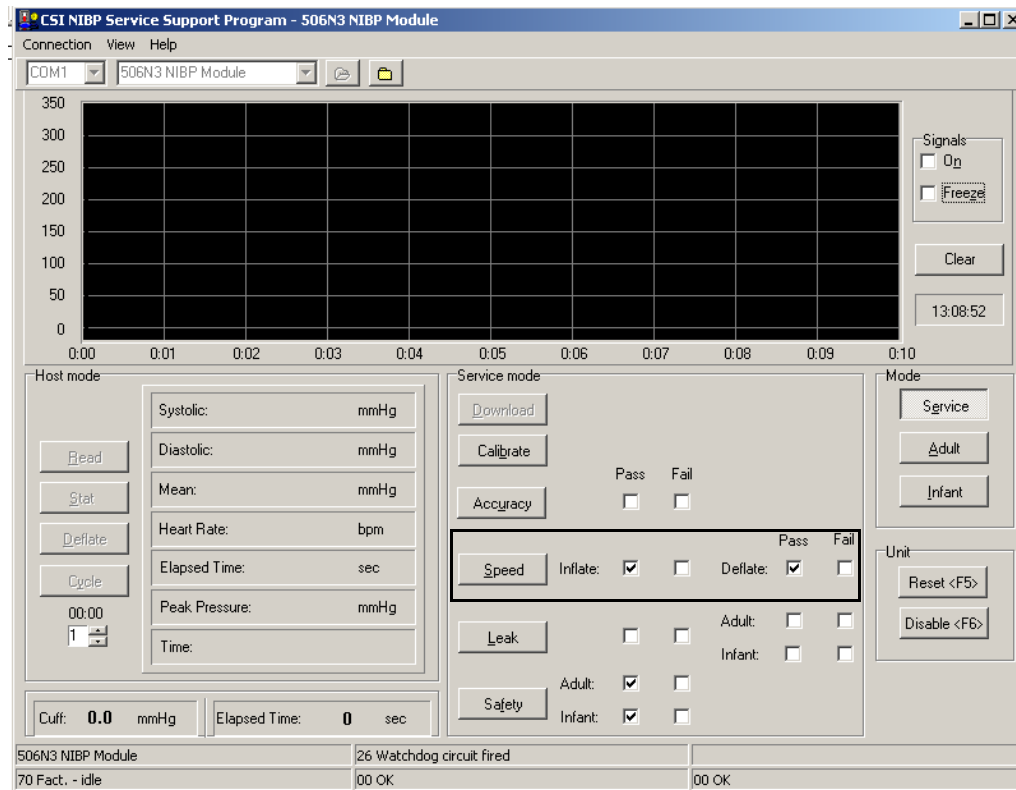

Figure 6-21: Speed Test Pass

Leak Test 1. Click on the *Leak* test button.

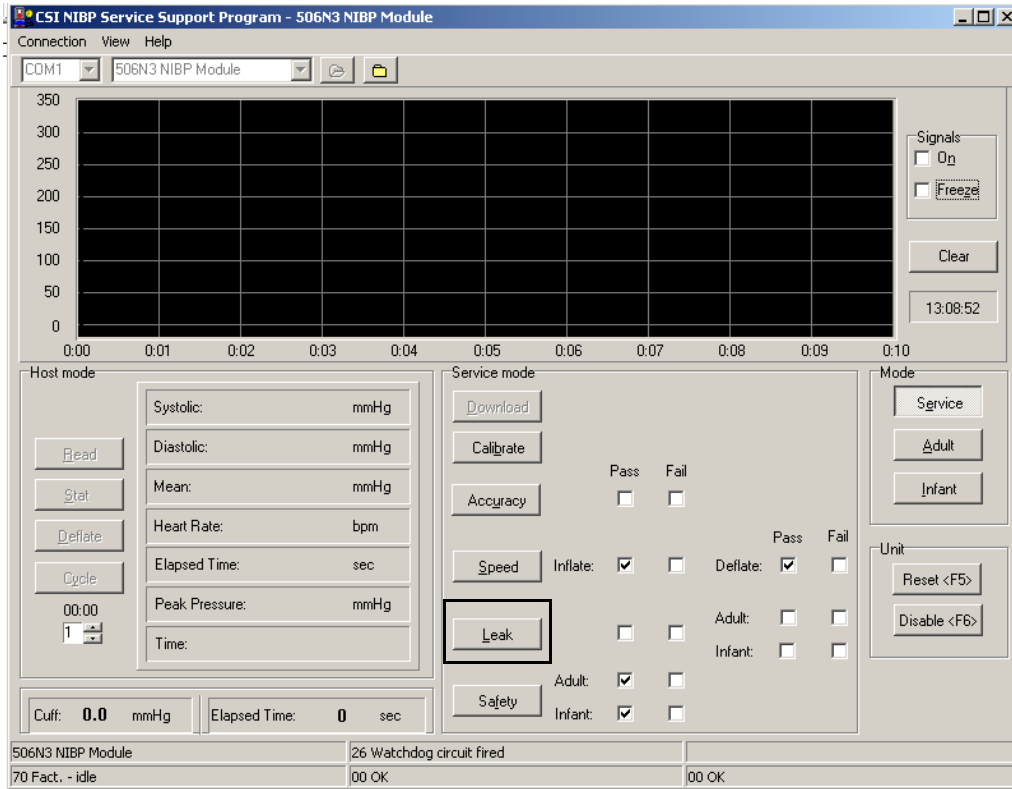

Figure 6-22: Select Leak

2. A *Leak and High Time Test* window appears. Click *Start*.

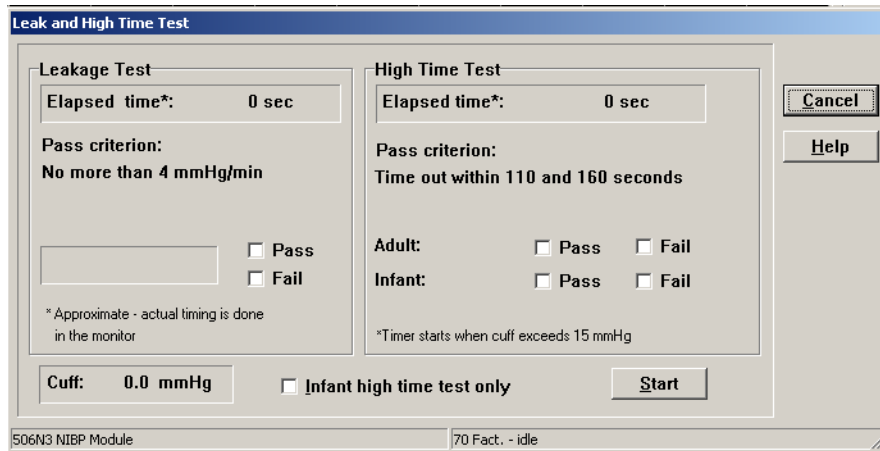

Figure 6-23: Leak and High Time Test Window

3. Verify that the *Pass criterion*: indicates a *Pass* for the *Leakage Test* by having a checkmark next to it in the box.

Leak and High Time Test

Leakage Test
 Elapsed time*: 59 sec
 Pass criterion:
 No more than 4 mmHg/min
 2 mmHg over 60 seconds:
 2 mmHg/min Pass Fail
 * Approximate - actual timing is done in the monitor

High Time Test
 Elapsed time*: 80 sec
 Pass criterion:
 Time out within 110 and 160 seconds
 Adult: Pass Fail
 Infant: Pass Fail
 *Timer starts when cuff exceeds 15 mmHg

Cuff: 238.0 mmHg Infant high time test only

506N3 NIBP Module 7A Fact. - leakage test measurement

Figure 6-24: Leakage Test Pass

4. Verify that the *High Time Test* indicates a *Pass* for *Adult* with a checkmark in the box.

Leak and High Time Test

Leakage Test
 Elapsed time*: 59 sec
 Pass criterion:
 No more than 4 mmHg/min
 2 mmHg over 60 seconds:
 2 mmHg/min Pass Fail
 * Approximate - actual timing is done in the monitor

High Time Test
 Elapsed time*: 127 sec
 Pass criterion:
 Time out within 110 and 160 seconds
 Adult: Pass Fail
 Infant: Pass Fail
 *Timer starts when cuff exceeds 15 mmHg

Cuff: 0 mmHg Infant high time test only

506N3 NIBP Module 10 Host - NIBP disabled

Figure 6-25: High Time Test, Adult

- Click on the *Infant high time test only*. A checkmark appears in the box. Click *Start*.

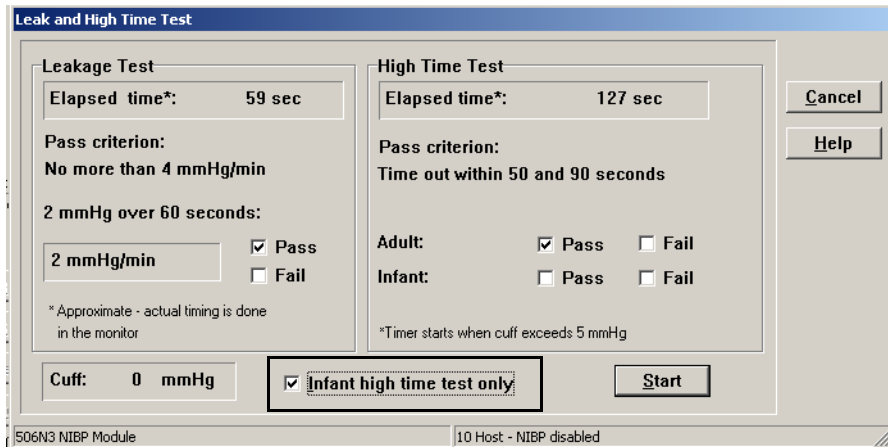

Figure 6-26: Infant High Time Test Only

- After approximately 60 seconds, the box next to *Pass* should contain a checkmark in front of it.

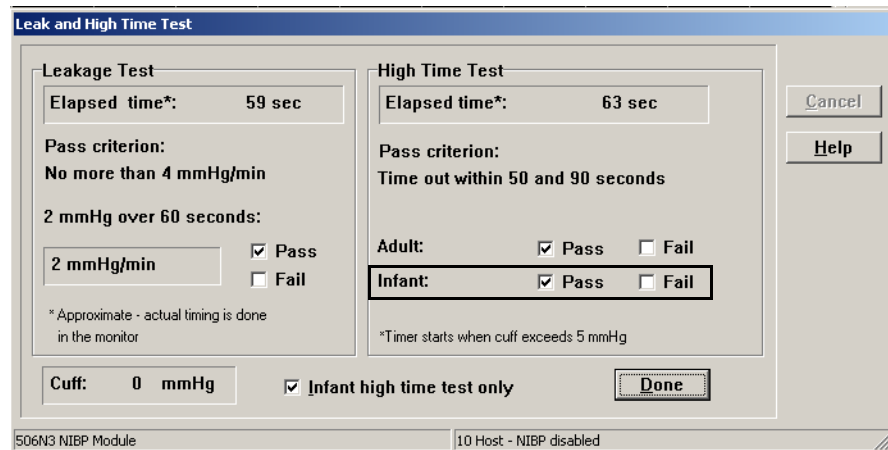
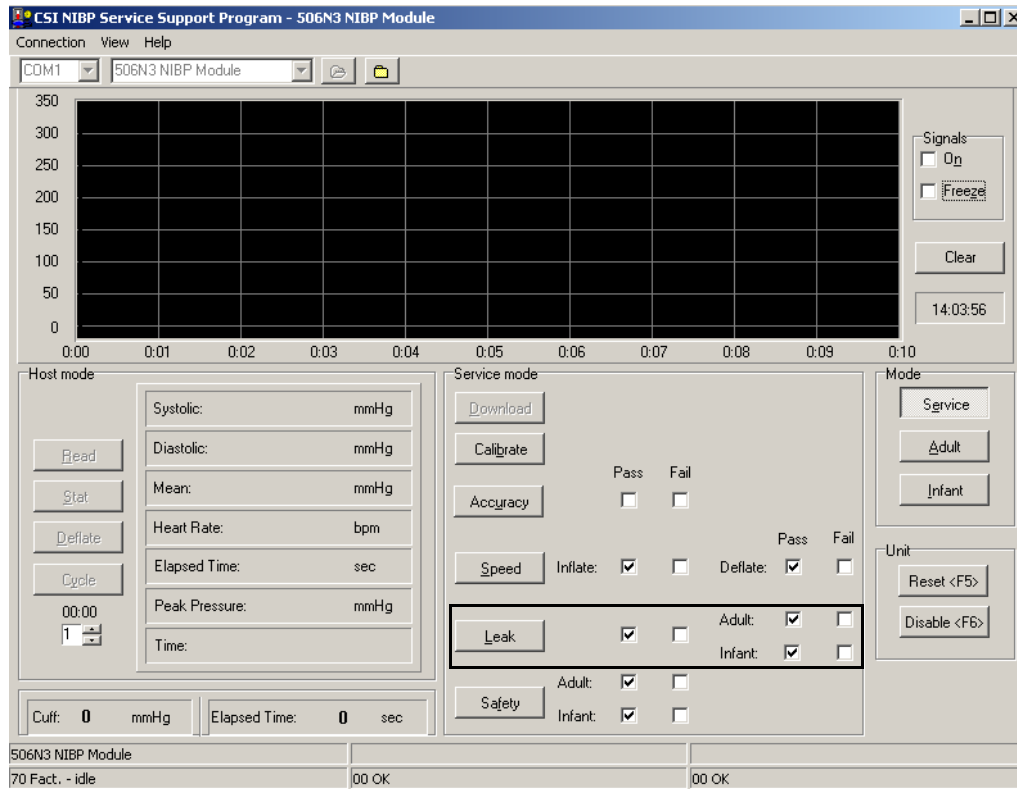

Figure 6-27: Infant High Time Test Pass

- If each *Pass* box has a checkmark, click on the *Done* button.

8. The main screen displays checkmarks indicating a *Pass* of the *Leak* tests.



Accuracy Test 1. Click on *Accuracy*.

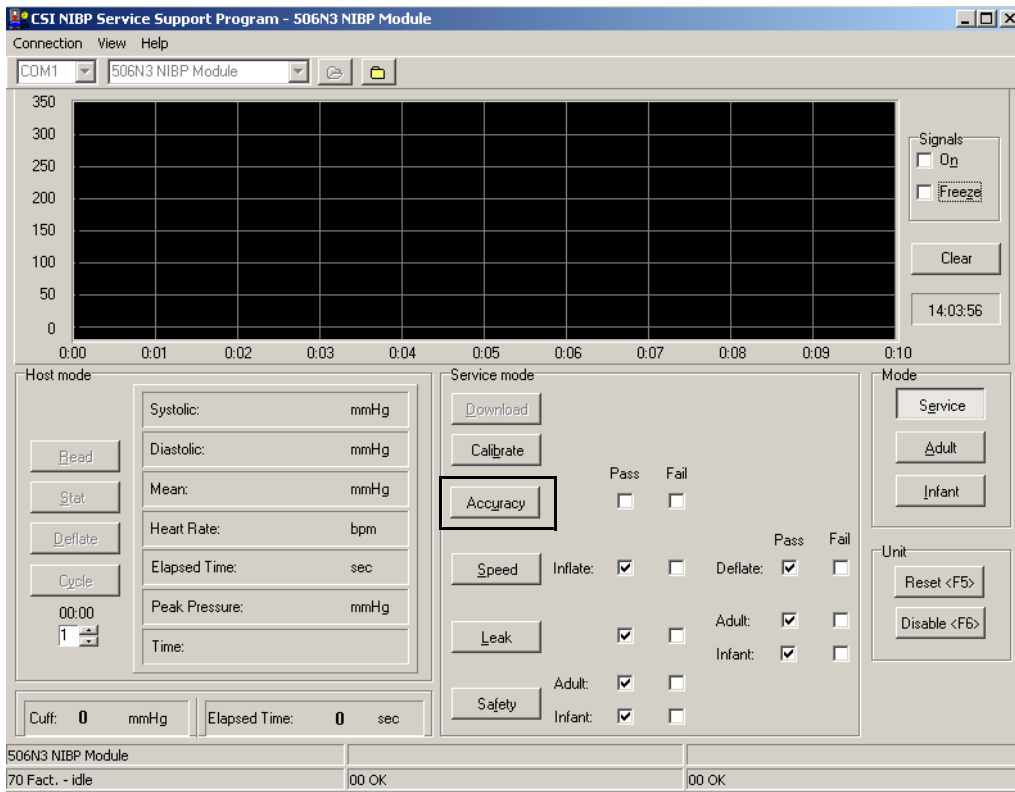

Figure 6-29: Select Accuracy

2. A *Pressure Accuracy Test* window appears. Click *Start*.

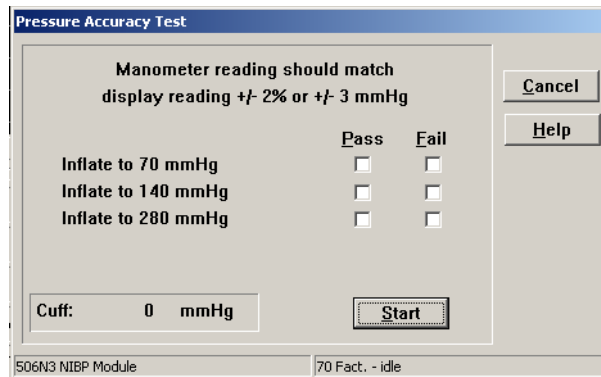

Figure 6-30: Pressure Accuracy Test Window

3. Check the manometer and the cuff pressure. Pressure will inflate to 70mmHg. Verify that the pressure is within $\pm 2\%$ or ± 3 mmHg. If OK click on the *Pass* box to place a checkmark in the box. Click *Next*.

| Manometer reading should match display reading $\pm 2\%$ or ± 3 mmHg | | Pass | Fail |
|--|-------------------------------------|--------------------------|------|
| ✓ Inflate to 70 mmHg | <input checked="" type="checkbox"/> | <input type="checkbox"/> | |
| ✓ Inflate to 140 mmHg | <input type="checkbox"/> | <input type="checkbox"/> | |
| Inflate to 280 mmHg | <input type="checkbox"/> | <input type="checkbox"/> | |

Cuff: 109.0 mmHg

Buttons: Cancel, Help, Next

Footer: 506N3 NIBP Module | 71 Fact. - controlled inflation

Figure 6-31: Pressure Accuracy Test, 70 mmHg

4. Repeat for 140 and 280mmHG.

| Manometer reading should match display reading $\pm 2\%$ or ± 3 mmHg | | Pass | Fail |
|--|-------------------------------------|--------------------------|------|
| ✓ Inflate to 70 mmHg | <input checked="" type="checkbox"/> | <input type="checkbox"/> | |
| ✓ Inflate to 140 mmHg | <input checked="" type="checkbox"/> | <input type="checkbox"/> | |
| Inflate to 280 mmHg | <input type="checkbox"/> | <input type="checkbox"/> | |

Indicate Pass or Fail for this inflation level

Cuff: 133.0 mmHg

Buttons: Cancel, Help, Next

Footer: 506N3 NIBP Module | 70 Fact. - idle

Figure 6-32: Pressure Accuracy Test, 140 mmHg

| Manometer reading should match display reading $\pm 2\%$ or ± 3 mmHg | | Pass | Fail |
|--|-------------------------------------|--------------------------|------|
| ✓ Inflate to 70 mmHg | <input checked="" type="checkbox"/> | <input type="checkbox"/> | |
| ✓ Inflate to 140 mmHg | <input checked="" type="checkbox"/> | <input type="checkbox"/> | |
| ✓ Inflate to 280 mmHg | <input checked="" type="checkbox"/> | <input type="checkbox"/> | |

Indicate Pass or Fail for this inflation level

Cuff: 273.0 mmHg

Buttons: Cancel, Help, Done

Footer: 506N3 NIBP Module | 70 Fact. - idle

Figure 6-33: Pressure Accuracy Test, 280 mmHg

5. Click *Done* if the test passes after the 280 mmHg test.
6. Turn off power and remove serial cable and manometer fixture.

Other Module Testing and Calibration

No additional performance testing is necessary for the temperature module. If the monitor fails the temperature verification in “Temperature Verification” in Section 5, replace the module as necessary. There is no service testing or calibration of the LCD or LED Board assemblies. See the functional tests in “Functional and Safety Tests” in Section 5.

Section 7 — Disassembly

Before You Begin

Opening a monitor and breaking the quality seal can void your manufacturer warranty! Contact the Criticare Service Department before you break the seal on any monitor.

The following procedures are intended to be used by qualified biomedical engineering or field service personnel for replacement of PCB assemblies. These procedures are not intended to be used for component-level trouble shooting and repair of the PCB assemblies.

The repair procedures for the 506N3 Series monitors are included here for the determination of damaged or unusable assemblies. The manufacturer does not recommend attempting field repair of the printed circuit boards.

Also see the 506N3 Series Final Assembly Drawings in Section 9.

Service Safety

WARNING

- The following procedures require working with exposed electrical circuits. Repair should only be attempted by experienced electronics technicians.
- Do not short circuit the battery terminals! The resulting high current discharge can cause burns.
- Before disassembly remove the battery to avoid electrical shock.
- Electronic components are selected for specific performance characteristics. Use of substitute replacement parts may cause inaccurate performance or damage to the monitor. Order replacement components by their catalog or part number from your authorized dealer.
- Any time an electronic circuit board is altered through repair or adjustment, it must be fully tested before use.

CAUTION

- Replacement of surface mount components is beyond the scope of this manual. Attempting to remove surface mount components with a soldering iron can result in the overheating of the board and damage to tracings. Damaged laminated circuit boards cannot be repaired and require replacement.
- Any electronic repair should be done in compliance with ANSI/IPC-A-610 manufacturing standards for medical equipment. Failure to use standard ANSI/IPC assembly practices can result in permanent damage to the monitor.

Electrostatic Discharge Protection



The procedures in this section require the handling of electrostatic sensitive components. Microprocessors and other electronic components can be permanently damaged by attempting repairs at an unprotected workstation.

Use all electrostatic discharge (ESD) protection as described below!

1. Perform the disassembly procedure on an antistatic mat that is grounded. Check the ground cable to insure that it is connected to a good earth ground.
2. Always use a grounded soldering iron.
3. Wear a wrist-grounding strap.
4. The wrist strap and mat should both be connected through a resistor (1 mega-ohm typical) to the same ground source.
5. Wrist-ground straps should be tested on a daily basis.
6. Components should be temporarily stored in metal or antistatic containers. Never store components in plastic dishes.
7. Circuit boards should be stored in sealed antistatic bags or covered antistatic boxes. Never store electronic boards directly in cardboard boxes.

Tools Needed

The following tools are needed for disassembly and reassembly of the VitalCare 506N3 Series monitor:

- #0 Phillips screwdriver with torque to 5 in. lbs.
- #1 Phillips screwdriver with torque to 5 in. lbs.
- #2 Phillips screwdriver with torque to 5 in. lbs.
- 8mm socket
- 10mm deep dish socket
- 3/16-inch nutdriver
- 1/4-inch nutdriver
- RTV (Dow Corning Adhesive RTV 3145 clear, or equivalent)

Replace the Printer

1. Follow the caution for static-sensitive devices in “Electrostatic Discharge Protection” in this section.
2. Turn the monitor off and disconnect the monitor from the AC (Mains) power source.
3. Remove the battery as described in “Battery Removal/ Replacement” in Section 5.
4. With a #1 Phillips screwdriver, remove the two (2) painted screws (pn 40193B002) from the printer assembly (pn 95745A001) on the back of the monitor.



Figure 7-1: Remove Screws from Printer Assembly

5. Press the front of the printer assembly to release the printer assembly from the tab.



Figure 7-2: Release Printer Tab

6. Lift the printer assembly up from the monitor.

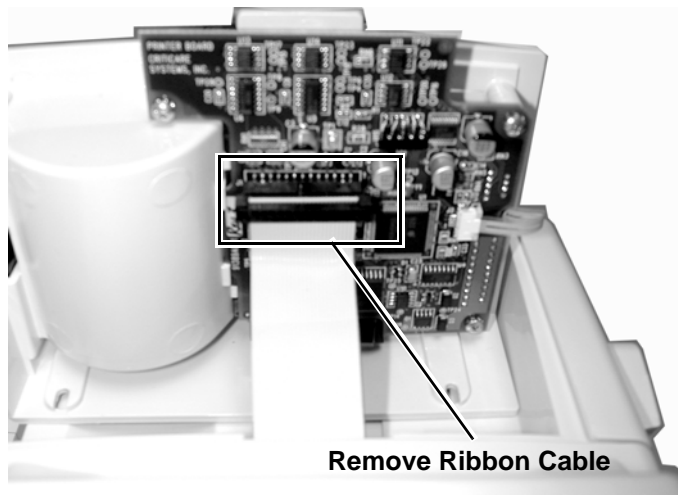

Figure 7-3: Lift Printer Assembly

7. Label and remove the printer ribbon cable (pn 90928A001) from the connection on the printer assembly.
8. Attach the printer ribbon cable to the new printer assembly.
9. Set the new printer assembly on the top of the monitor. Press the assembly until it snaps into place.
10. Fasten the printer assembly to the monitor with the two (2) painted screws removed earlier.

NOTE: While securing the two (2) screws, press down on the rear of the printer housing to keep the printer flush with the monitor's rear housing.

11. Reconnect the battery as described in "Battery Removal/ Replacement" in Section 5.
12. Perform a functional test of the printer as described in "Functional and Safety Testing" in Section 5.

Replace the Temperature Boards

1. Follow the caution for static-sensitive devices in “Electrostatic Discharge Protection” in this section.
2. Turn the monitor off and disconnect the monitor from the AC (Mains) power source.
3. Remove the battery as described in “Battery Removal/Replacement” in Section 5.
4. Remove the four (4) gray-coated P.H.M.S. screws from the side panel (pn 45171B001, 45171C001, 45196B001, or 45196B002).

NOTE: On monitors with DOX SpO₂ there is a holding clip for the SpO₂ cable. Do not lose this clip.

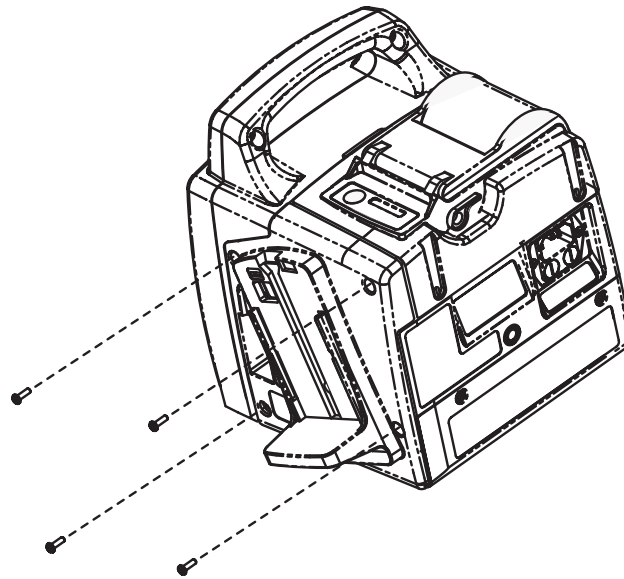

Figure 7-4: Remove Screws

NOTE: The following procedures, “Replacing the FasTemp Isolation Board,” “Replacing the FasTemp Board,” and “Replacing the TurboTemp Board,” are configuration specific. Follow the procedure(s) appropriate for the temperature module in your monitor.

Replacing the FasTemp Isolation Board

Refer to “Replace the Temperature Boards” on page 7-5 for directions on removing the side panel.

1. Carefully lift the side panel up and then lift the two foam pads from the insulator that are holding the cables down.

NOTE: Putting a strain on the flex cable will cause the flex cable to disconnect from the Temperature board or the Isolation Board.

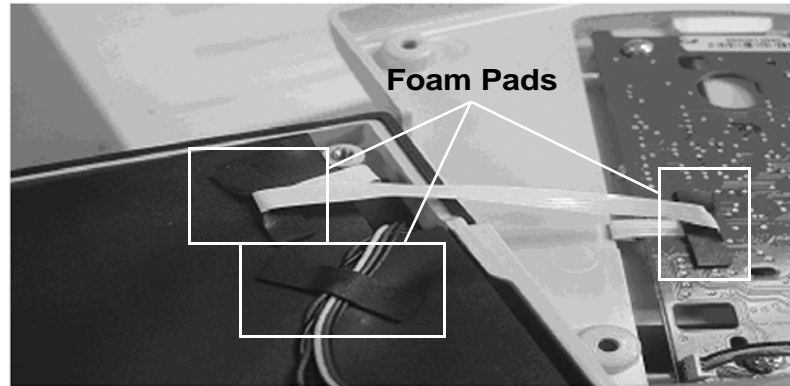

Figure 7-5: Lift Foam Pads

2. Place a small box or similar object the size of the monitor under the side panel to keep it level.
3. Lift the insulator up of the side panel.

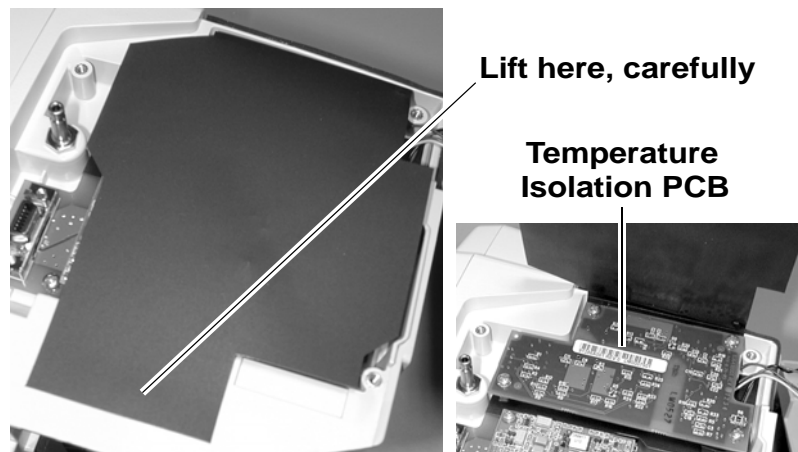

Figure 7-6: Lift Insulator

- Remove the four (4) screws (pn 40995B005) from the isolation PCB.

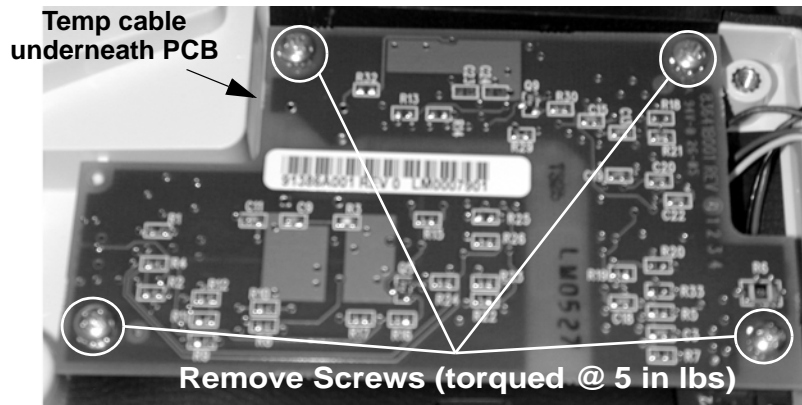

Figure 7-7: Remove Isolation Board Screws

- Carefully lift up the isolation PCB (pn 91386A001).
- Remove the Temp cable (pn 90931A001) from the connector beneath the PCB.

NOTE: Do not tuck temp cable into opening.

- Flip the PCB over and disconnect the black and red wire from **J3** of the isolation board. (This cable is soldered to the FasTemp PCB.)

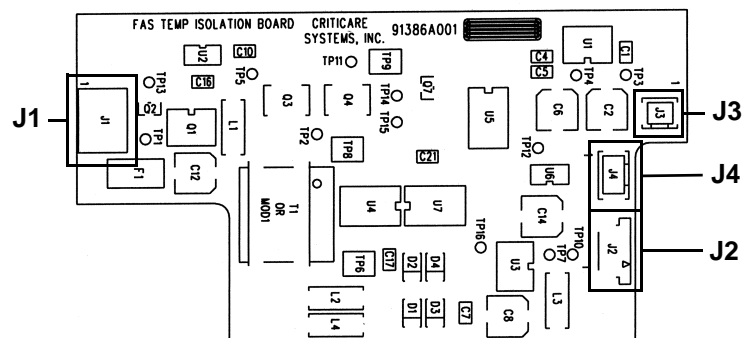

Figure 7-8: Isolation Board Connectors

- Disconnect the RS232 cable (pn 90933A001) from **J4** on the isolation PCB.
- Disconnect the flex cable (pn 83266B002) from **J2** by unlocking the tab and pulling it out.

NOTE: Make sure that the contacts will face up when reinserting the cable.

- Replace the isolation PCB.
- Reassemble in reverse order.

Follow “Completion of Service” procedure at the end of this section.

Replacing the FasTemp Board

Refer to “Replace the Temperature Boards” on page 7-5 for directions on removing the side panel.

1. Carefully lift the side panel up and then lift the two foam pads from the insulator that are holding the cables down.

NOTE: Putting a strain on the flex cable will cause the flex cable to disconnect from the Temperature board or the Isolation Board.

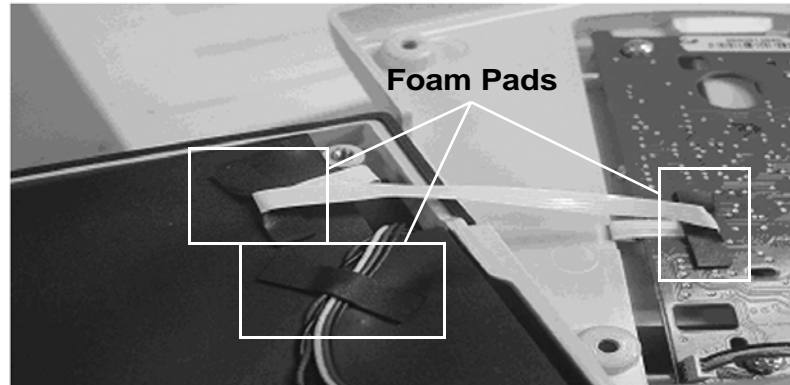

Figure 7-9: Lift Foam Pads

2. Place a small box or similar object the size of the monitor under the side panel to keep it level.
3. Lift the insulator up of the side panel.

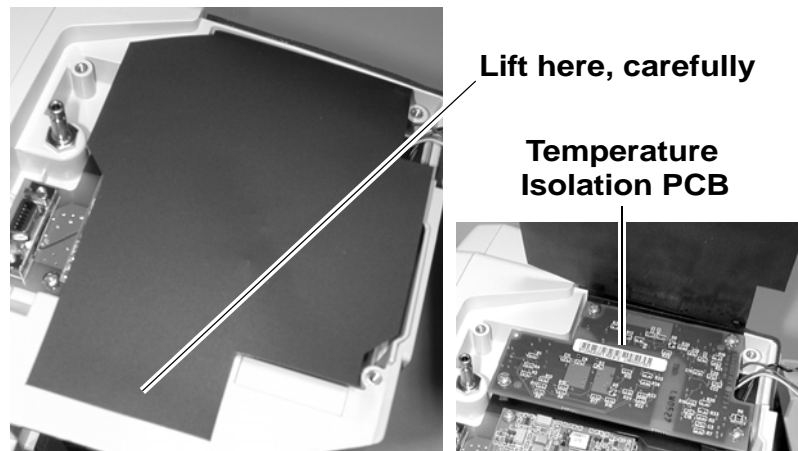

Figure 7-10: Lift Insulator

- Remove the four (4) screws (pn 40995B005) from the isolation PCB.

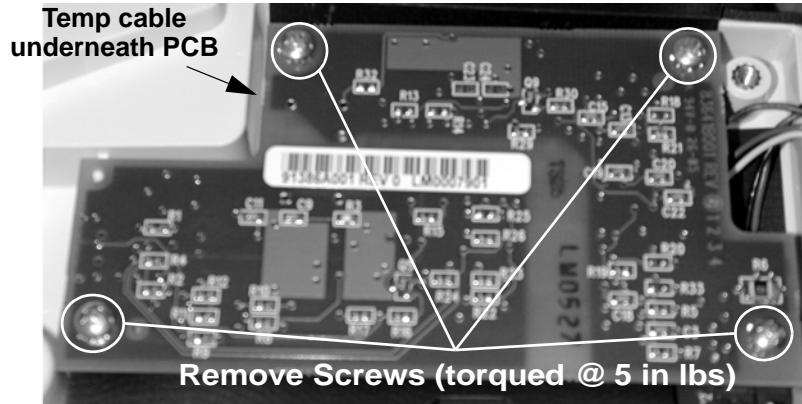

Figure 7-11: Remove Isolation Board Screws

- Carefully lift up the isolation PCB (pn 91386A001).
- Remove the Temp cable (pn 90931A001) from the connector (**J1**) beneath the PCB.

NOTE: Do not tuck temp cable into opening. Add RN to connector after reassembly.

NOTE: The connector is locking. Inserting cable incorrectly will result in damage if powered up.

- Flip the PCB over and disconnect the black and red wire from **J3** of the isolation board. (This cable is soldered to the FasTemp PCB.)

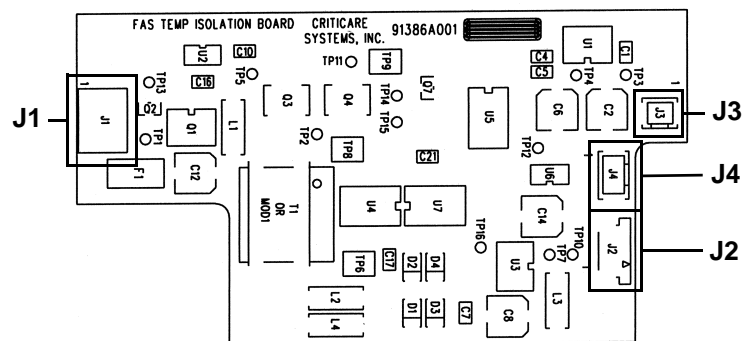

Figure 7-12: Isolation Board Connectors

8. Remove the three (3) screws (pn 40995B005) with nylon washers (pn 40283B001) that are holding the FasTemp Board to the side panel.

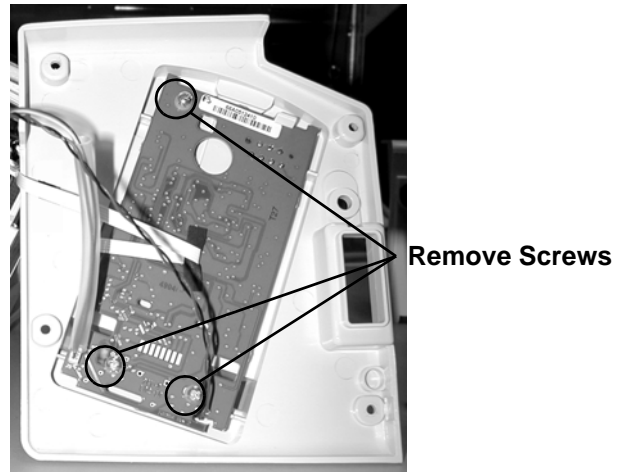

Figure 7-13: Remove Screws from FasTemp PCB

9. Press the tab at the top of the side panel to release the FasTemp Board from the side panel.

NOTE: Under the bottom of the Board are two (2) insulating washers. **DO NOT LOSE.** These must be positioned as shown.

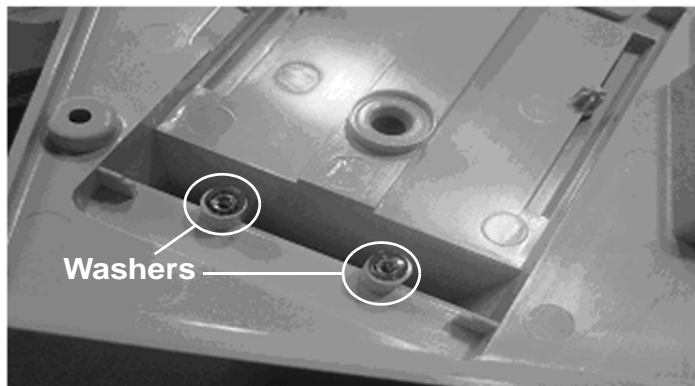

Figure 7-14: DO NOT Lose Washers

10. Lift the pad that is holding the flex cable to the FasTemp Board.
11. Remove the flex cable from the FasTemp Board by unlocking the connector (**J3**) of the FasTemp Board.

NOTE: The silver pads of the flex cable face down to connect to the FasTemp Board. Same direction pad is placed on the Isolation Board.

 **CAUTION** 

- Ensure that the ribbon cable is attached to the locking connectors with the proper polarity. Failure to place the ribbon cable properly can damage the Temperature Assembly. Ensure the contacts *face* the board at **J3** on the FasTemp Board.
12. Disconnect the RS232 cable (pn 90933A001) from **J5** on the FasTemp Board.
 13. Replace the FasTemp Board.
 14. Reassemble in reverse order.
- Follow “Completion of Service” procedure at the end of this section.

Replacing the TurboTemp Board

Refer to “Replace the Temperature Boards” on page 7-5 for directions on removing the side panel.

1. Carefully lift the side panel.
2. Remove the Temp Cable (pn 90931A001) from the connector beneath the PCB (**J1**).

NOTE: Cable is locking. If the cable is placed into the connector reversed, the board will not function and may cause damage.

Disconnect Temperature Cable

**Remove Screws
Torque
@ 3 in lbs**

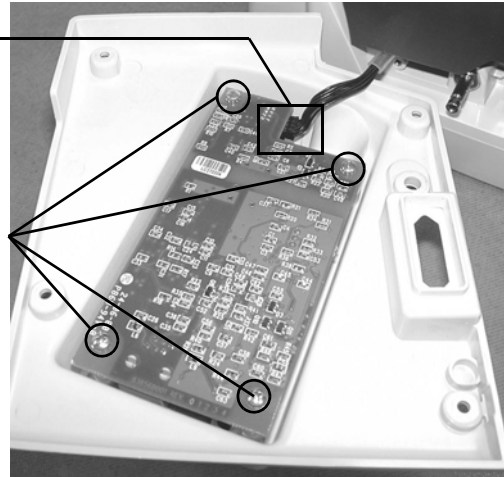

Figure 7-15: Remove Temp Cable and Screws

3. Place side panel with TurboTemp Board facing upwards (Component side down).
4. Remove the four (4) screws (pn 40995B009) from the TurboTemp Board (see above). Torque of screws is 3 in. lbs.
5. Carefully lift up. (The side panel has the temp holder attached).
6. Replace the TurboTemp Board.
7. Reassemble in reverse order.

Follow “Completion of Service” procedure at the end of this section.

Replace the SpO₂ Board

1. Follow the caution for static-sensitive devices in “Electrostatic Discharge Protection” in this section.
2. Turn the monitor off and disconnect the monitor from the AC (Mains) power source.
3. Remove the battery as described in “Battery Removal/Replacement” in Section 5.
4. Remove the four (4) gray-coated P.H.M.S. screws from the side panel (pn 45170B001, 45170C001, 45171B001, 45171C001, 45196B001, or 45196B002.)

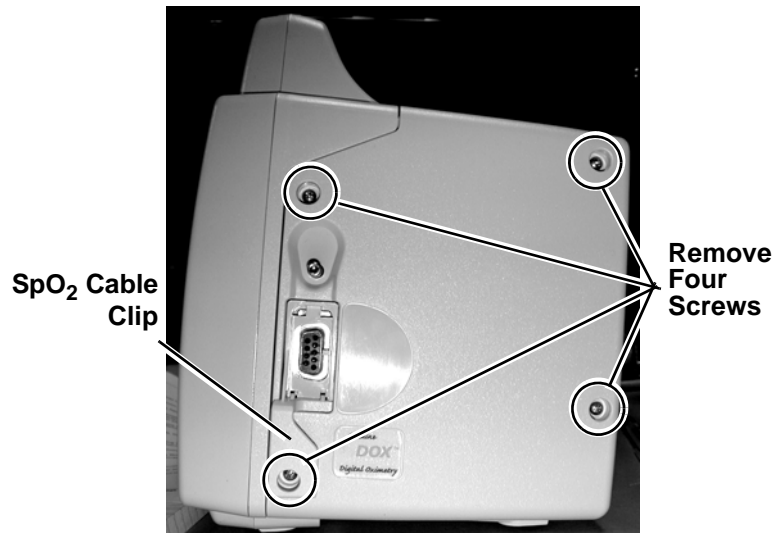

Figure 7-16: Side Panel, No Temperature Models

NOTE: The following procedures are configuration specific. Follow the procedure appropriate for your monitor.

DOX SpO₂ with TurboTemp
or without Temperature

Refer to “Replace the SpO₂ Boards” on page 7-13 for directions on removing the side panel.

1. Lift the insulator up off the side panel.

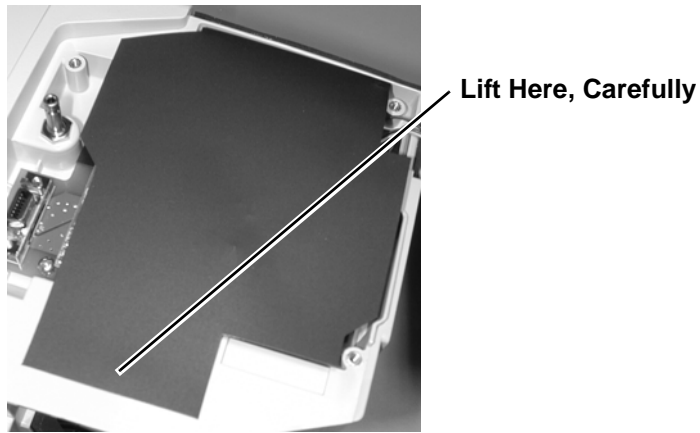

Figure 7-17: Lift Insulator

2. Remove the standoffs (pn 42476B001) that hold the DOX SpO₂ Board to the base assembly.

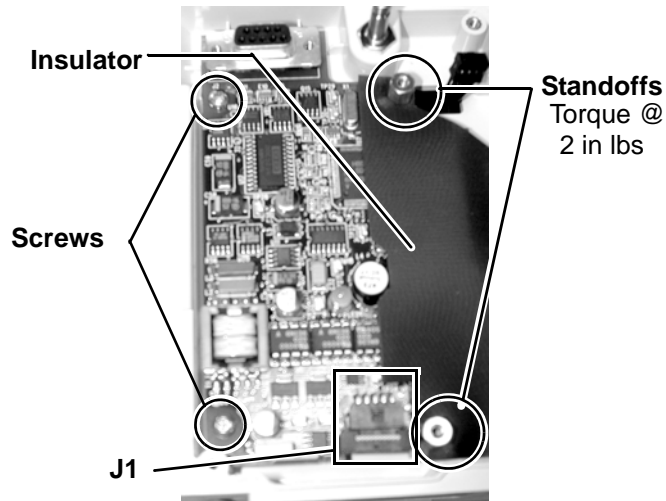

Figure 7-18: DOX SpO₂ PCB

NOTE: Insulator is placed on top of PCB, then standoffs.

3. Remove insulator.
4. Remove the two (2) screws that are holding the DOX PCB to the base assembly. Torque @ 5 in. lbs.
5. Unplug the SpO₂ cable (pn 90930A001) from **P1** of the PCB.
6. Replace DOX SpO₂ PCB.
7. Reassemble in reverse order.

Follow “Completion of Service” procedure at the end of this section.

DOX SpO₂
with FasTemp

Refer to “Replace the SpO₂ Boards” on page 7-13 for directions on removing the side panel.

1. Carefully lift the side panel up and then lift the two foam pads from the insulator that are holding the cables down.

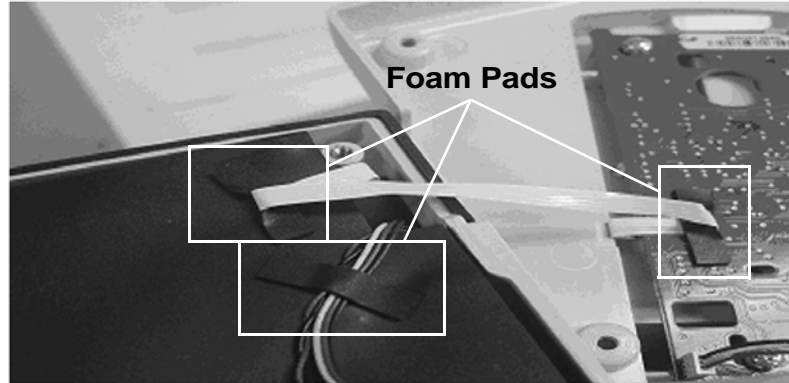

Figure 7-19: Lift Foam Pads

2. Place a small box or similar object the size of the monitor under the side panel to keep it level.
3. Lift the insulator up off the side panel.

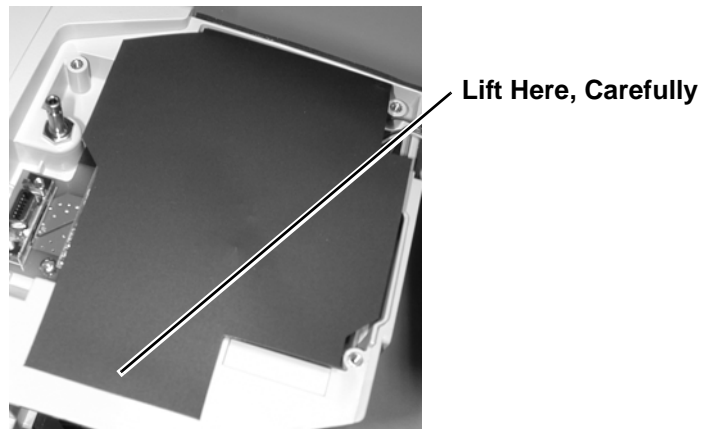

Figure 7-20: Lift Insulator

4. Remove the four (4) screws (pn 40995B005) from the FasTemp Isolation PCB.

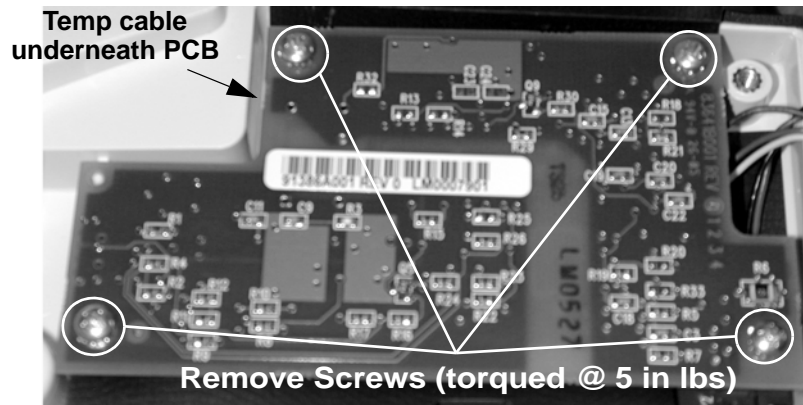

Figure 7-21: Remove Isolation Board Screws

5. Carefully lift up the Isolation PCB (pn 91386A001).
6. Remove the Temp cable (pn 90931A001) from the connector beneath the PCB.

NOTE: DO not tuck the temp cable into the opening. Add RN to connector after reassembly.

NOTE: The connector is locking. Inserting the cable incorrectly will cause damage if powered up.

7. Remove the standoffs (pn 42476B001) that hold the DOX SpO₂ Board to the base assembly.

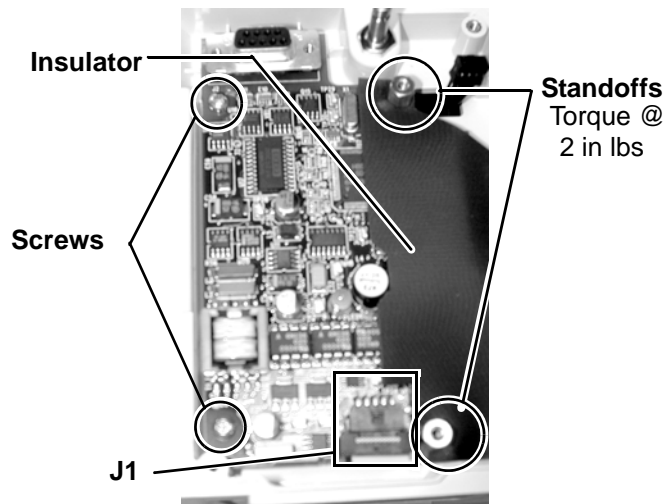

Figure 7-22: DOX SpO₂ PCB

NOTE: Insulator is placed on top of PCB, then standoffs.

8. Remove the insulator.
9. Remove the two (2) screws (pn 40995B005) that are holding the DOX SpO₂ PCB to the base assembly. Torque is 5 in. lbs.

10. Unplug the SpO₂ cable (pn 90930A001) from **P1** of the PCB.

11. Replace the DOX SpO₂ PCB.

12. Reassemble in reverse order.

Follow “Completion of Service” procedure at the end of this section.

Nellcor SpO₂
PCB /Carrier Board
with TurboTemp
or without Temperature

Refer to “Replace SpO₂ Boards” on page 7-13 for directions on removing the side panel.

1. Carefully lift up the side panel.
2. Lift the insulator off of the side panel.
3. Remove the standoffs (pn 42476B001) that are holding the insulator to the PCB. Torque is 2 in. lbs.

NOTE: Insulator is placed on top of PCB, then standoffs.

4. Remove the insulator.
5. Remove the two (2) screws (pn 40995B005) that are holding the Nellcor Carrier PCB (pn 91387A001) to the base assembly. Torque is 5 in. lbs.
6. Unplug the SpO₂ cable (pn 90930A001) from **P1** of the PCB.
7. Remove the two (2) screws (pn 41258B003) from the top of the Nellcor PCB. Torque is 2 in. lbs.

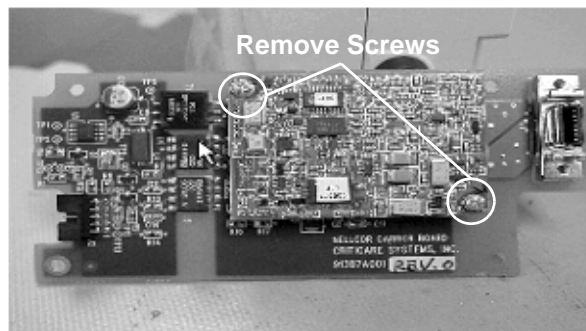

Figure 7-23: Removing Carrier PCB

8. Lift the Nellcor PCB (pn 83459B001) up from its connectors.
9. Remove the two (2) standoffs (pn 42255B004) and two (2) nuts (pn 40008B003) that are attached to the carrier PCB. Torque is 1 in. lbs.
10. Replace the Nellcor Carrier PCB (pn 91387A001) and/or Nellcor PCB (pn 83459B001).
11. Reassemble in reverse order.

Follow “Completion of Service” procedure at the end of this section.

Nellcor SpO₂
PCB /Carrier Board
with FasTemp

Refer to “Replace the SpO₂ Boards” on page 7-13 for directions on removing the side panel.

1. Carefully lift the side panel up and then lift the two foam pads from the insulator that are holding the cables down.

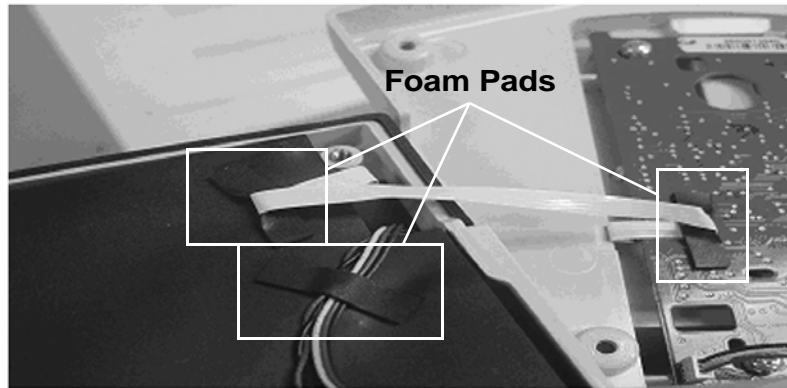

Figure 7-24: Lift Foam Pads

2. Place a small box or similar object the size of the monitor under the side panel to keep it level.
3. Lift the insulator up off the side panel.

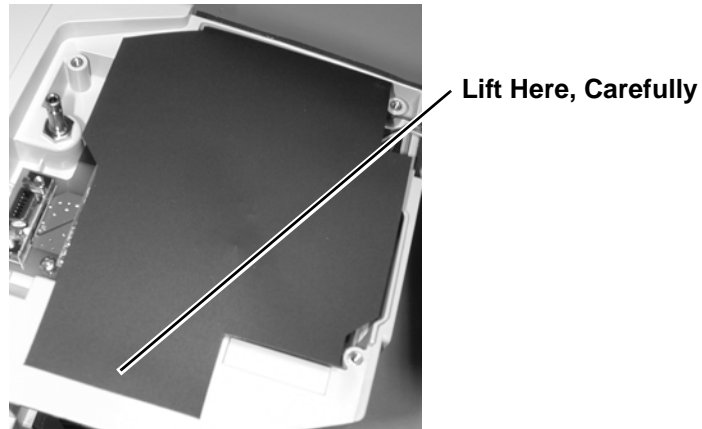

Figure 7-25: Lift Insulator

4. Remove the four (4) screws (pn 40995B005) from the FasTemp Isolation PCB.

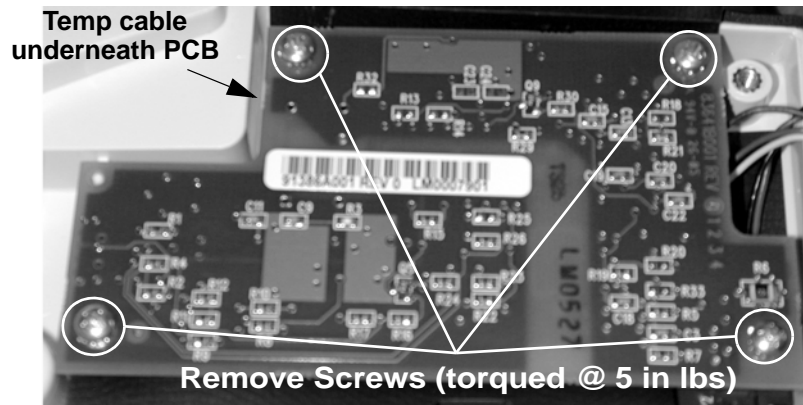

Figure 7-26: Remove Isolation Board Screws

5. Carefully lift up the Isolation PCB (pn 91386A001).
6. Remove the Temp cable (pn 90931A001) from the connector beneath the PCB.

NOTE: Do not tuck temp cable into opening. Add RTV to the connector after reassembly.

7. Remove the standoffs (pn 42476B001) that are holding the insulator PCB. Torque is 2 in. lbs.

NOTE: Insulator is placed first, then standoffs.

8. Remove the insulator.
9. Remove the two (2) screws (pn 40995B005) that are holding the Nellcor Carrier PCB (pn 91387A001) to the base assembly. Torque is 5 in. lbs.
10. Unplug the SpO₂ cable (pn 90930A001) from **P1** of the PCB.
11. Remove the two (2) screws (pn 41258B003) from the top of the PCB. Torque is 2 in. lbs.

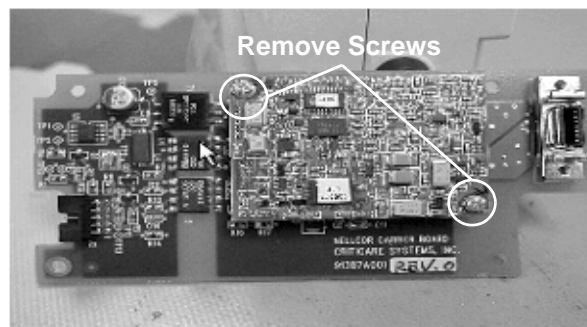

Figure 7-27: Removing Carrier PCB

12. Lift the Nellcor PCB (pn 83459B001) up from its connectors.

13.Remove the two (2) standoffs (pn 42255B004) and two (2) nuts (pn 40008B003) that are attached to the carrier PCB. Torque is 1 in. lbs.

14.Replace the Nellcor Carrier PCB (pn 91387A001) and/or Nellcor PCB (pn 83459B001).

15.Reassemble in reverse order.

Follow “Completion of Service” procedure at the end of this section.

Front Bezel Service

Disassemble Front Bezel from Rear Housing

1. Follow the caution for static-sensitive devices in “Electrostatic Discharge Protection” in this section.
2. Turn the monitor off and disconnect the monitor from the AC (Mains) power source.
3. Remove the battery as described in “Battery Removal/ Replacement” in Section 5.
4. Flip the unit over and loosen the four (4) gray-coated screws (pn 40195B005). There are two (2) screws at the top of the handle and two (2) screws at the bottom of the rear housing. Torque is 5 in. lbs.

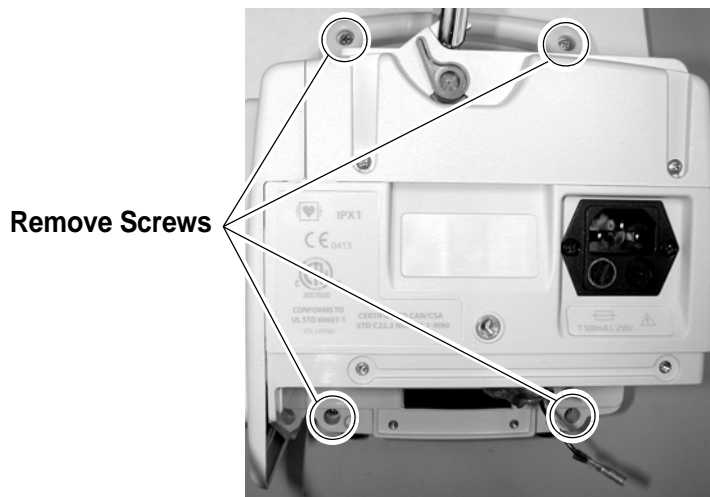

Figure 7-28: Remove Screws Holding Bezel

5. Carefully pull the front bezel away from the rear housing.
6. Disconnect the remaining cables from the main board.

NOTE: Inserting cables incorrectly during reassembly will cause damage.

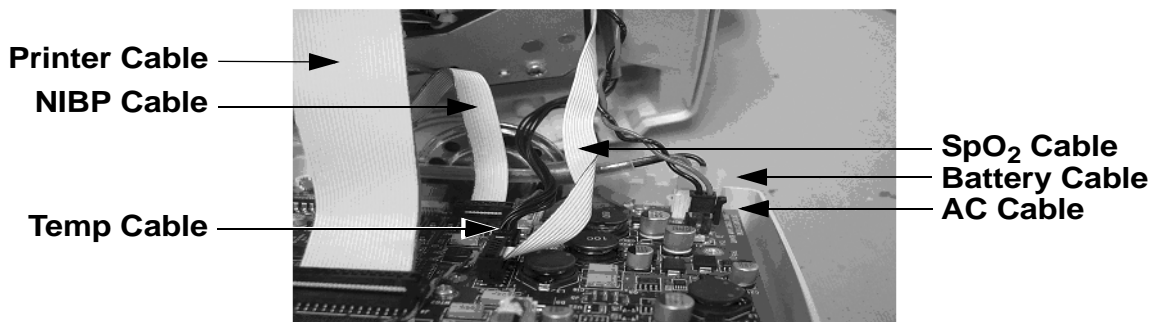

Figure 7-29: Disconnect Cables

-
7. Disconnect the battery cable at **J12** on the Main Board.
 8. Disconnect the AC cable at **J10** on the Main Board.
 9. Disconnect the NIBP cable at **J9** on the Main Board. (Locking side is up. Red is left.)
 10. Disconnect the SpO₂ cable at **J6** on the Main Board.
(Connector is locking. Pin 1 is red side up.)
 11. Disconnect the printer cable at **J4** on the Main Board.
 12. Disconnect the ground wire (at **P3** on the Main Board) from the chassis. (This step is only necessary if the monitor has an older Main Board (pn 91384A001 or 91384A002). Monitors with new Main Boards (pn 91384A003 or newer) do not have ground wires.)
 13. Reassemble in reverse order.

Follow “Completion of Service” procedure at the end of this section.

Replace Main Board **NOTE:** If upgrading the Main Board from pn 91384A001 or 91384A002 to pn 91384A003, refer to “Appendix A – Main Board Upgrades” for more details.

First perform “Disassemble Front Bezel from Rear Housing” procedure.

1. Remove the speaker from the rail of the bezel. Lift the orange and brown wires from the relief of main as shown below.

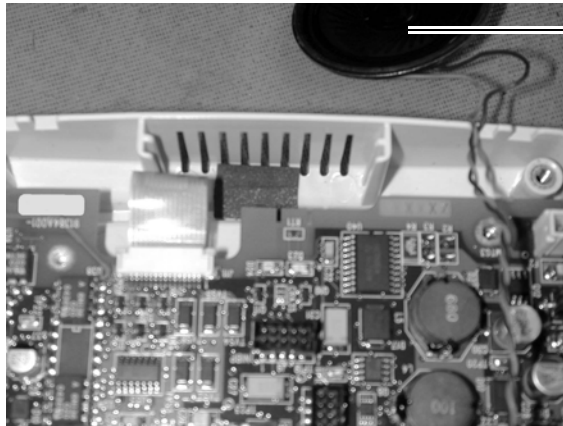

Speaker

Figure 7-30: Remove Speaker

2. Unplug the speaker assembly (pn 90932A001) from **J3** of the Main Board. Place speaker assembly aside.
3. With a #1 Phillips screwdriver, remove the screw (pn 40995B005) and washer (pn 40086B002) holding the folded tab from the membrane to the Main Board.

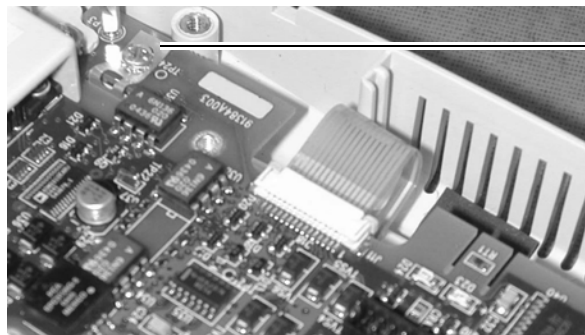

**Folded Tab
from Membrane**

Figure 7-31: Membrane Tab

NOTE: If replacing an older Main Board (pn 91384A001 or 91384A002), remove the two (2) screws holding the ground wire to the Main Board. Disconnect the green ground wire from **P3** on the Main Board.

4. Remove the four(4) remaining screws located on the top, bottom left and middle. (Or three (3) screws on the top and middle if the monitor had a ground wire which you removed in the previous step.)

5. Unlock the membrane tail at **J11** and remove the tail from the connector.
6. Remove the assembly from the bezel.
7. Flip the PCB over. Using a #0 Phillips screwdriver, remove all four (4) screws (pn 41258B003) from the LCD display. Lift and remove.
8. Using a #1 Phillips screwdriver, remove the six (6) screws (pn 40995B005) from the display board (pn 91388A001). Lift and remove. There will be a display board header beneath the display board.
9. Using a 1/4 nut driver, remove the slide collar that is over the DB-9 connector. A #1 Phillips screwdriver may be needed to hold the screw on the other side.
10. Using a 3/16 nut driver, remove the standoffs and nuts that are attached to the Main Board.
11. Replace the Main Board.

REASSEMBLY

1. Mount four (4) standoffs M/F (pn 42255B003) onto the Main Board (PCB side without connectors) using four (4) nuts (pn 40008B005).
 2. Install LCD Display Assembly (pn 90029A001) to the Main Board assembly using four (4) #2 screws (pn 41258B003). Torque to 2 in. lbs.
 3. Plug display board header (pn 87282B001) into Main Board at **J1** or **J7**.
 4. Carefully place and align the LED display board assembly (pn 91388A001) onto the main board using the standoffs as a guide and make sure header is connected into display board.
 5. Mount the LED display board using six (6) P.H.M.S. screws (pn 40995B005). Torque to 5 in. lbs.
 6. Slide collar over the DB-9 connector and mount this to the Main Board using two (2) P.N.M.S. screws (pn 40995B006) and securing with two (2) nuts (pn 40284B001).
- NOTE:** Nuts will lie on top of collar plastic. Torque to 5 in. lbs.
7. Air out the bezel with an air ionizer before mounting PCB. Place the ground tail from the membrane through the opening of the Main Board assembly (pn 90232A001).

8. Tilt the PCB assembly so that it is on an angle. Lift the bezel up so that the tail of the membrane slides through the opening of the PCB assembly. Place the two together and lay back down onto the table.
9. Mount the PCB assembly to the bezel using four (4) P.H.M.S. screws (pn 40995B005). (These are upper screws. DO NOT tighten down.)
10. Unlock connector from membrane and attach the membrane tail into it. Close the connector by pushing it close. Keep the membrane straight and even.

11. Fold over the membrane's ground tail and connect to the Main Board using a P.H.M.S. screw and washer. Attach the right side of the bezel and torque all five (5) screws at 5 in. lbs.

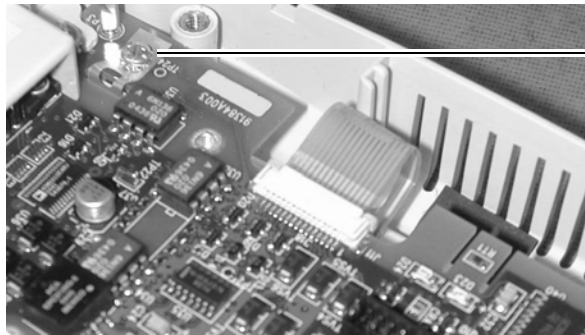

**Membrane
Ground Tail**

Figure 7-32: Membrane Ground Tail

If the monitor previously contained a pn 91384A001 or 91384A002 Main Board that was replaced with a 91384A003 Main Board:

- a. Reuse the black ground wire that was removed in Step 3 by inserting P.H.M.S. screws through the ring terminal (lower right corner) and both holes of the ground tail. (This is done in place of the washer stated above.)
- b. Remove the green ground wire from the metal chassis.

**Remove green
ground wire**

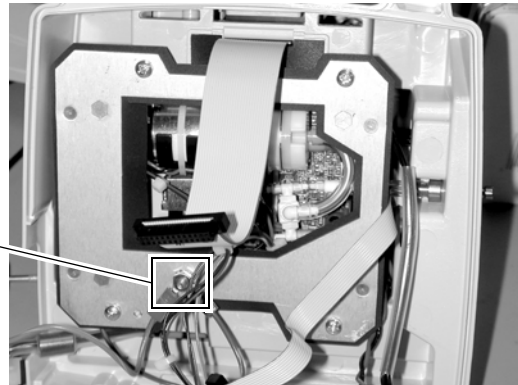

**Figure 7-33: Remove Ground Wire from Chassis
(Main Board Upgrades)**

If the monitor contained a pn 91384A001 or 91384A002 Main Board and the replacement is a pn 91384A001 or 91384A002 Main Board:

- a. Reuse the black ground wire that was removed in Step 3 by inserting P.H.M.S. screws through the ring terminal (lower right corner) and both holes of the ground tail. (This is done in place of the washer stated above.)
- b. Reconnect the green ground wire at **P3** on the Main Board.

12. Route the black ground wire under the membrane tail (if necessary).
13. Plug speaker assembly (pn 90932A001) into **J3** of the Main Board.
14. Slide the speaker into the front rail of the bezel. Place the orange and brown wires into relief as shown below.

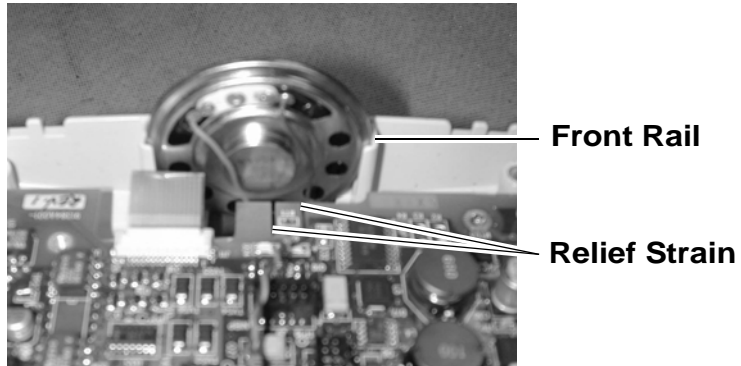

Figure 7-34: Reinsert Speaker

Reassemble monitor and follow “Completion of Service” procedure at the end of this section.

Replace Speaker First perform “Disassemble Front Bezel from Rear Housing” procedure.

1. Unplug the speaker cable from J3 on the Main Board.
2. Remove the speaker from the rail of the front bezel.

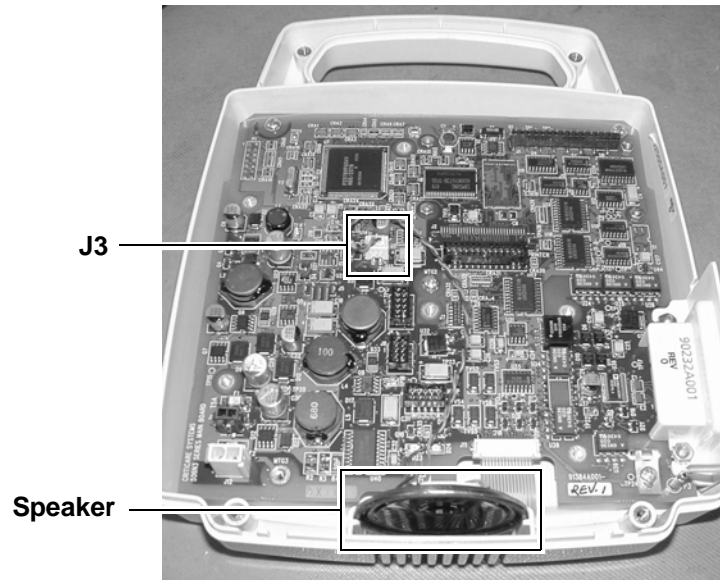

Figure 7-35: Removing Speaker

3. Slide the new speaker into the rail of the front bezel. The speaker should rest in the upper slot on the bezel. Insert wires into slots on the Main Board.

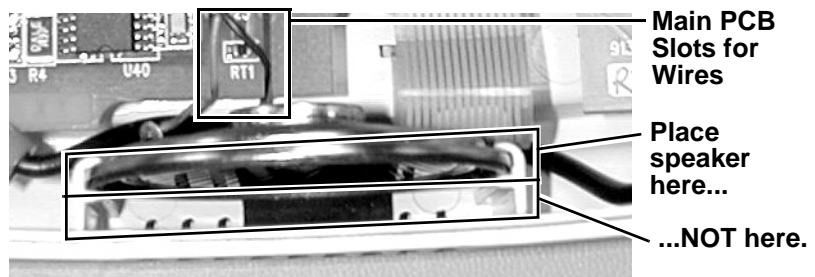

Figure 7-36: Inserting Speaker into Bezel

NOTE: The black ground wire shown in Figure 7-36 will not be present in monitors with 91384A003 Main Boards (unless the 91384A003 Main Board was installed as part of a Main Board upgrade).

4. Plug the new speaker cable to J3 on the Main Board. Route the wire assembly along the Main Board, as shown.



Figure 7-37: Route Speaker Cable

5. Reassemble in reverse order.

⚠ CAUTION ⚠

- When closing the front bezel onto the monitor make sure no wires are pinched between the bezel and the monitor. This will damage the wires.
- Do not allow the battery cable ferrites to the coils on the Main Board. This will damage the coils on the Main Board. Route the battery cable directly above and as close as possible to the speaker.

Reassemble monitor and follow “Completion of Service” procedure at the end of this section.

Replace LCD and LED Display Boards

First perform “Disassemble Front Bezel from Rear Housing” procedure.

1. Remove the speaker from the rail of the front bezel. Lift the orange and brown wires from the relief of main as shown below.

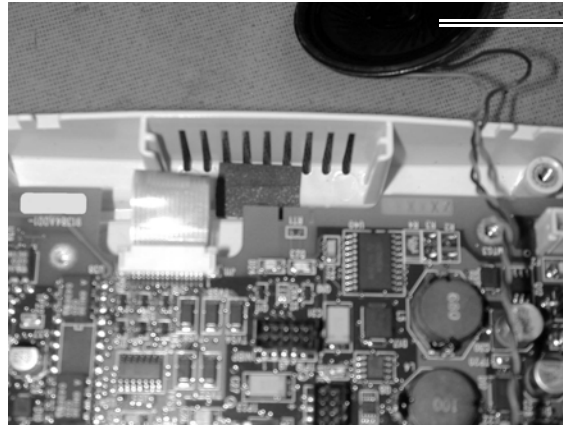

Speaker

Figure 7-38: Remove Speaker

2. Unplug the speaker assembly (pn 90932A001) from **J3** of the Main Board. Place speaker assembly aside.
3. With a #1 Phillips screwdriver, remove the screw (pn 40995B005) and washer (40086B002) holding the folder tab from the membrane to the Main Board.

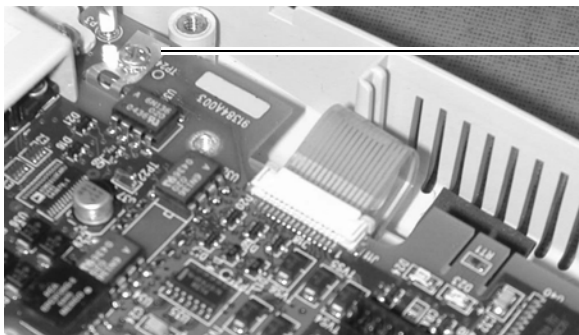

Folded Tab from Membrane

Figure 7-39: Membrane Tab

NOTE: If the monitor has an older Main Board (pn 91384A001 or 91384A002), remove the two (2) screws holding the ground wire to the Main Board. Disconnect the green ground wire from **P3** on the Main Board.

4. Remove the four(4) remaining screws located on the top, bottom left and middle. (Or three (3) screws on the top and middle if the monitor had a ground wire which you removed in the previous step.)

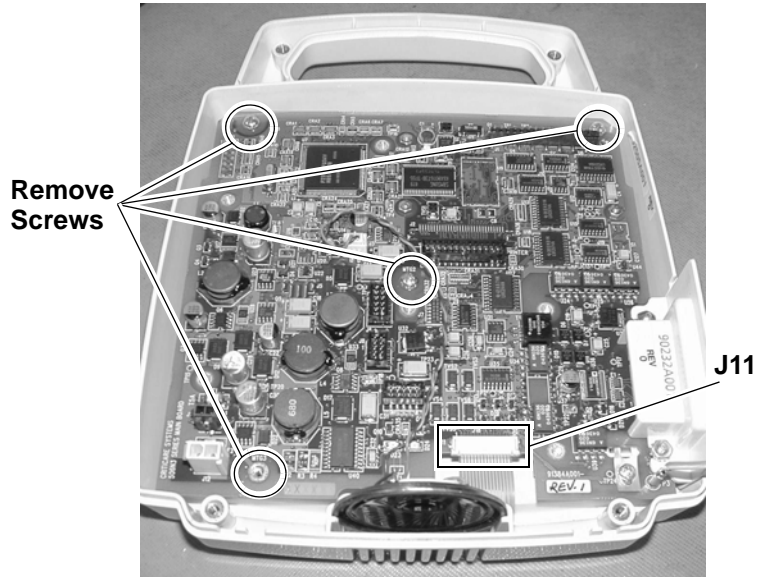

Figure 7-40: Remove Screws

5. Unlock the membrane tail at **J11** and remove the tail from the connector.
6. Remove the assembly from the bezel.

NOTE: For monitors with a Bezel Support (pn 45190B001), retain the Bezel Support.

7. Flip the assembly over. Determine which assembly needs to be replaced.
 - If the LCD board needs to be replaced, remove the four (4) screws (pn 41258B003) using a #0 Phillips screwdriver.
 - If the LED board needs to be replaced, remove the six (6) screws (pn 40995B005) using a #1 Phillips screwdriver.
 - Carefully attach either the new LCD board (pn 90029A001) or LED display board (91388A001).

REASSEMBLY

1. Place the LCD back onto the Main Board, aligning it carefully with the 16 pin holes at the top of the PCB. Insert the four (4) screws and torque to 2 in. lbs. Remove the film from the display.

For the LED display, be sure to place the display board header (pn 87282B001) into main board marked **J7** or **J1** of the display PCB. Insert the six (6) screws and torque to 5 in. lbs.

2. Air out the bezel with an air ionizer before mounting the PCB. Remove the film from the display. Place the ground tail from the membrane through the opening of the main board assembly (pn 90232A001).

NOTE: If the monitor has a bezel support, first replace the bezel support around the NIBP LEDs. The bezel support goes around the SYS/DIA (systolic/diastolic) LEDs with the middle bar between the two LED groups.

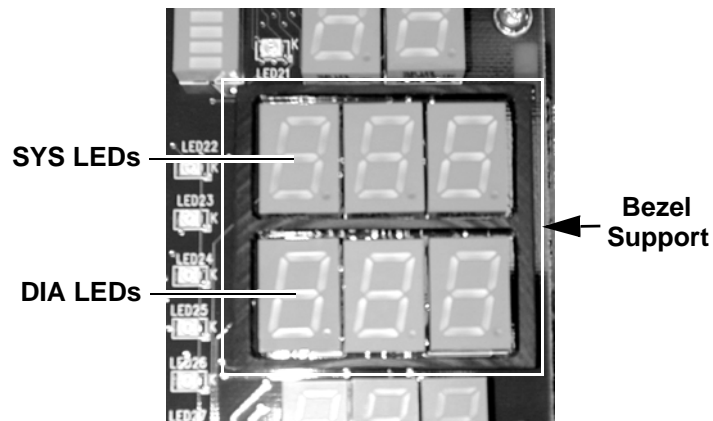

Figure 7-41: Bezel Support

3. Tilt the PCB assembly so that it is on an angle. Lift the bezel up so that the tail of the membrane slides through the opening of the PCB assembly. Place the two together and lay back down onto the table.
4. Mount the PCB assembly to the bezel using four (4) P.H.M.S. screws (pn 40995B005). (These are upper screws. DO NOT tighten down.)
5. Unlock connector from membrane and attach the membrane tail into it. Close the connector by pushing it close. Keep the membrane tail straight and even.

6. Fold over the membrane's ground tail and connect to the Main Board using a P.H.M.S. screw and washer. Attach the right side of the bezel and torque all five (5) screws at 5 in. lbs.

NOTE: If the monitor has an old Main Board (pn 91384A001 or 91384A002) or previously had a Main Board upgrade and still contains the black ground wire, install a P.H.M.S. screw through the ground cable assemble (pn 95602A001) and secure it to the lower left-hand corner of the bezel. Attach the ground flex circuit from membrane by folding over the ground tail and inserting P.H.M.S. screws through the ring terminal and both holes of the ground tail. Attach the right side of the bezel and torque all screws at 5 in. lbs. Route the black ground wire under the membrane tail.

If the monitor has a pn 91384A001 or 91384A002 Main Board, reattach the green ground wire at **P3** on the Main Board.

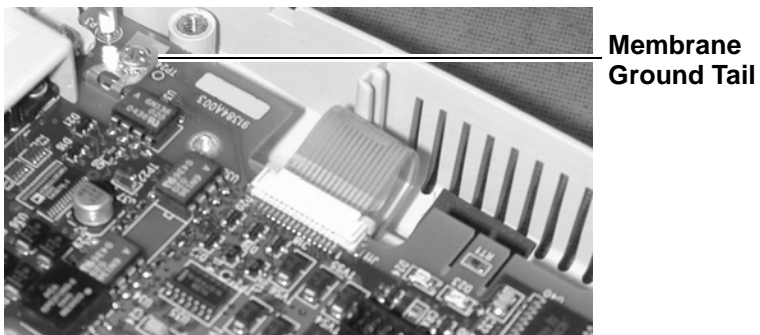

Figure 7-42: Membrane Ground Tail

7. Plug speaker assembly (pn 90932A001) into **J3** of the Main Board.
8. Slide the speaker into the front rail of the bezel. Place the orange and brown wires into relief as shown below.

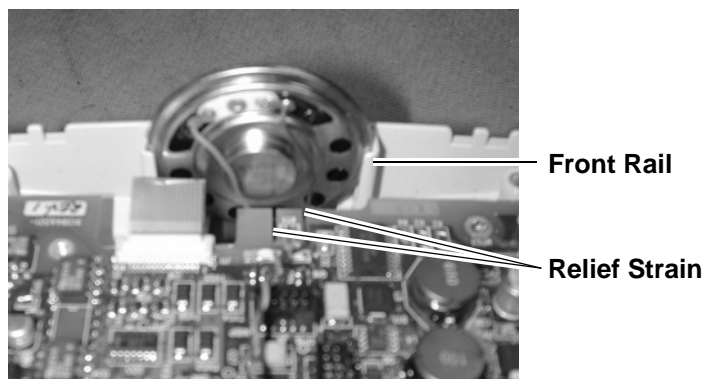
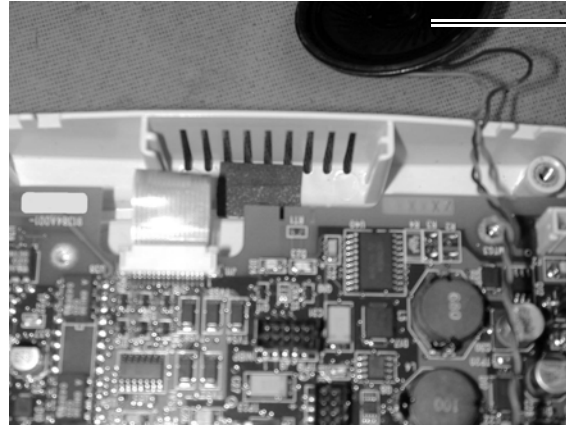

Figure 7-43: Reinsert Speaker

Reassemble monitor and follow "Completion of Service" procedure at the end of this section.

Replace Membrane First perform “Disassemble Front Bezel from Rear Housing” procedure.

1. Remove the speaker from the rail of the front bezel. Lift the orange and brown wires from the relief of main as shown below.



Speaker

Figure 7-44: Remove Speaker

2. Unplug the speaker assembly (pn 90932A001) from **J3** of the Main Board. Place speaker assembly aside.
3. With a #1 Phillips screwdriver, remove the screw (pn 40995B005) and washer (pn 40086B002) holding the folded tab from the membrane to the Main Board.

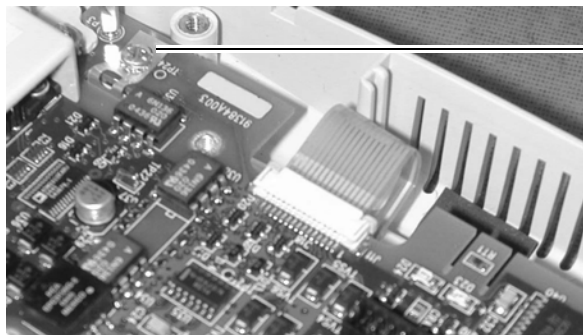

**Folded Tab
from Membrane**

Figure 7-45: Membrane Tab

NOTE: If the monitor has an older Main Board (pn 93184A001 or 91384A002), remove the two (2) screws holding the ground wire to the Main Board. Disconnect the green ground wire from **P3** on the Main Board.

4. Remove the four (4) remaining screws located on the top, bottom left and middle. (Or three (3) screws on the top and middle if the monitor had a ground wire which you removed in the previous step.)

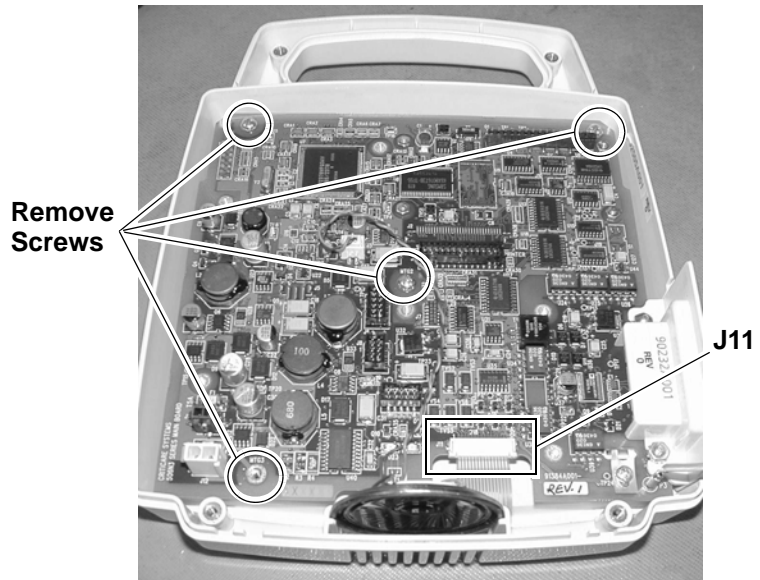

Figure 7-46: Remove Screws

5. Unlock the membrane tail at **J11** and remove the tail from the connector.
6. Remove the Main Board and display assembly from the bezel.
7. Flip the bezel over. Remove the old membrane by pushing through any opening on the back.
8. Once removed, clean the front of the bezel with alcohol. Remove any residue from the bezel surface.
9. Obtain a new membrane.

NOTE: See Section 9, “Drawings and Schematics,” for the correct part number for the replacement membrane for the monitor.

10. Remove the paper backing from the membrane. Place the membrane flush with the bezel and slide each tail through the openings that are provided on the bezel. Press firmly around the bezel to ensure that the membrane is flat and no air bubbles are apparent.
11. Air out the bezel with an air ionizer before mounting the PCB. Remove the film from the display. Place the ground tail from the membrane through the opening of the main board assembly (pn 90232A001).

12. Tilt the PCB assembly so that it is on an angle. Lift the bezel up so that the tail of the membrane slides through the opening of the PCB assembly. Place the two together and lay back down onto the table.
13. Mount the PCB assembly (pn 90232A001) to the bezel using four (4) P.H.M.S. screws (pn 40995B005). (These are the upper screws. Do Not tighten down.)
14. Unlock connector from membrane and attach the membrane tail into it. Close the connector by pushing it close. Keep the membrane straight and even.
15. Fold over the membrane's ground tail and connect to the Main Board using a P.H.M.S. screw and washer. Attach the right side of the bezel and torque all five (5) screws at 5 in. lbs.

NOTE: If the monitor has an old Main Board (pn 91384A001 or 91384A002), install a P.H.M.S. screw through the ground cable assemble (pn 95602A001) and secure it to the lower left-hand corner of the bezel. Attach the ground flex circuit from membrane by folding over the ground tail and inserting P.H.M.S. screws through the ring terminal and both holes of the ground tail. Attach the right side of the bezel and torque all screws at 5 in. lbs. Route the ground wire under the membrane tail.

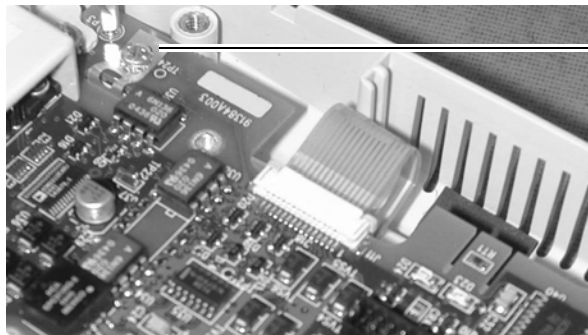

Figure 7-47: Flex Cable Ground

16. Plug speaker assembly (pn 90932A001) into **J3** of the Main Board.

17. Slide the speaker into the front rail of the bezel. Place the orange and brown wires into relief as shown below.

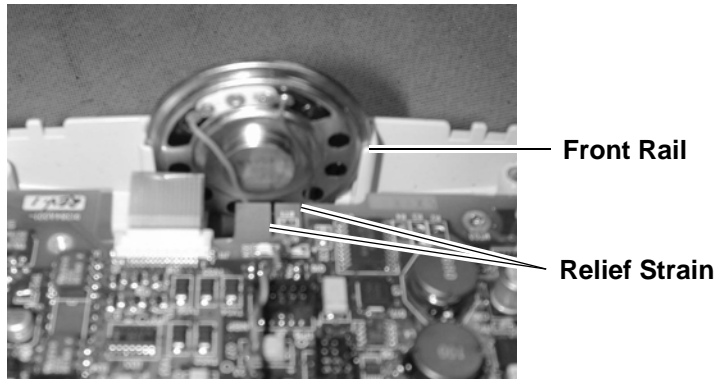

Figure 7-48: Reinsert Speaker

Reassemble monitor and follow “Completion of Service” procedure at the end of this section.

Chassis Service/ Pump Disassembly

1. Follow the caution for static-sensitive devices in “Electrostatic Discharge Protection” in this section.
2. Turn the monitor off and disconnect the monitor from the AC (Mains) power source.
3. Remove the battery as described in “Battery Removal/ Replacement” in Section 5.
4. Flip the monitor over and loosen the four (4) gray-coated screws (pn 40195B005). There are two (2) screws at the top of the handle and two (2) screws at the bottom of the rear housing. Torque to 5 in. lbs.

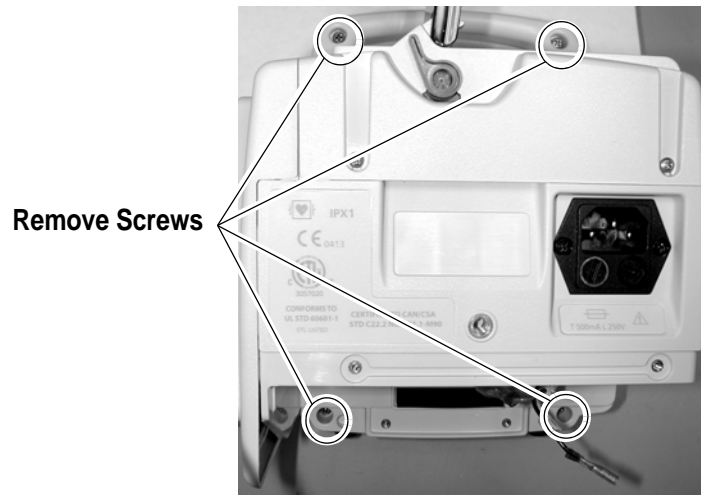

Figure 7-49: Remove Screws Holding Bezel

5. Carefully pull the front bezel away from the rear housing.
6. Disconnect the remaining cables from the main board.

NOTE: Inserting cables incorrectly during reassembly will cause damage.

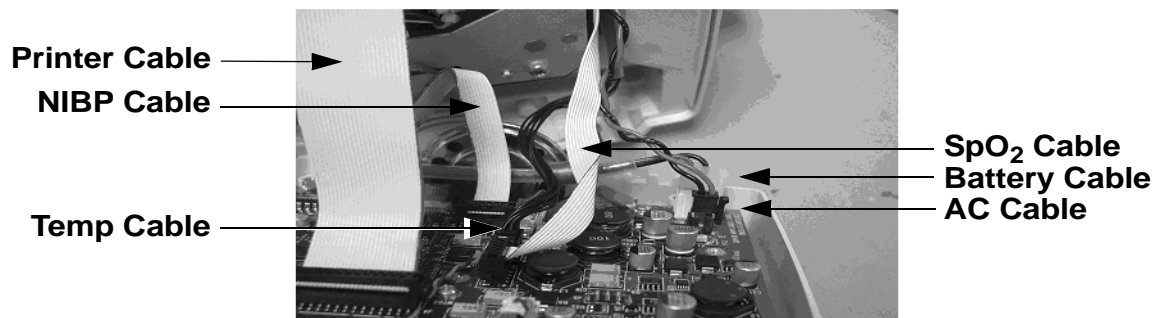

Figure 7-50: Disconnect Cables

7. Disconnect the battery cable at J12 on the Main Board.
8. Disconnect the AC cable at **J10** on the Main Board.

9. Disconnect the NIBP cable at **J9** on the Main Board. (Locking side is up. Red is left.)
10. Disconnect the SpO₂ cable at **J6** on the Main Board. (Connector is locking. Pin 1 is red side up.)
11. Disconnect the printer cable at **J4** on the Main Board.
12. Disconnect the ground wire (at **P3** on the Main Board) from the chassis. (This step is only necessary if the monitor has an older Main Board (pn 91384A001 or 91384A002). Monitors with new Main Boards (pn 91384A003 or newer) do not have ground wires.)
13. Remove the four (4) gray-coated P.H.M.S. screws from the side panel.

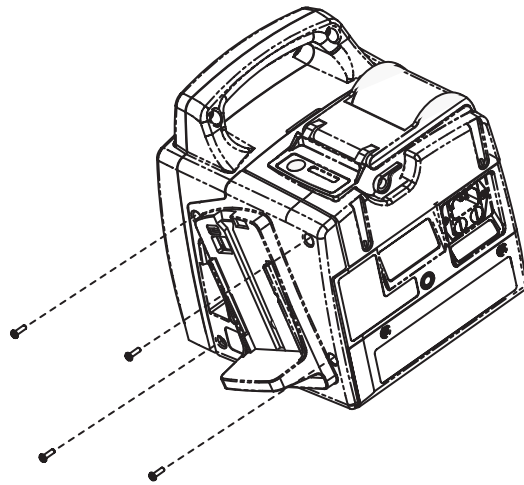

Figure 7-51: Remove Side Panel

14. With a 10mm deep dish socket remove the NIBP fitting.

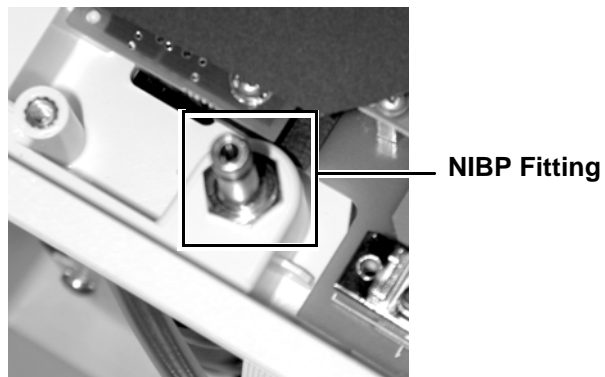

Figure 7-52: Remove NIBP Fitting

15. With a 1/4 nut driver, loosen the nut holding the ground wire.

Replace ComfortCuff NIBP Module

First perform “Chassis Service/Pump Disassembly” procedure.

1. With the #2 Phillips screwdriver, remove the four (4) screws (pn 40496B004) holding the chassis assembly in place.

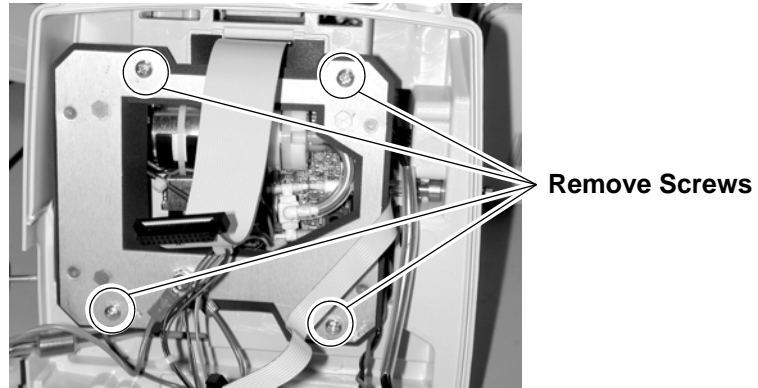

Figure 7-53: Remove Four Screws (Chassis)

2. Slide the chassis out of the rear housing and pull the NIBP fitting from the opening on the right side of the rear housing. Keep temp and SpO₂ cables (temp units) to the right.
3. Remove the ground wire from **JP1**.
4. Remove the harness from **CN1**.
5. Flip the chassis up with the power supply facing up.
6. Loosen the four (4) screws (pn 40496B001) that are contained with the four (4) #6 cup washers (pn 42499B001). Lift the power supply PCB (pn 86517C001) up and remove the four cup washers that lie beneath the power supply.
7. Loosen the four (4) screws (pn 40995B006) attached to the chassis beneath the power supply. Torque at 5 in. lbs.
8. Lift the NIBP module up. (The direction of the fitting faces the same direction as the shape of the chassis opening.
9. Unplug the NIBP cable (pn 90926A002) from the NIBP module (pn 93947A003) at **J1**. Note that the connector is locking.
10. Replace the NIBP module.
11. Reassemble in reverse order.

Reassemble monitor and follow “Completion of Service” procedure at the end of this section.

Replace Power Supply First perform “Chassis Service/Pump Disassembly” procedure.

1. With the #2 Phillips screwdriver, remove the four (4) screws (pn 40496B004) holding the chassis assembly in place.

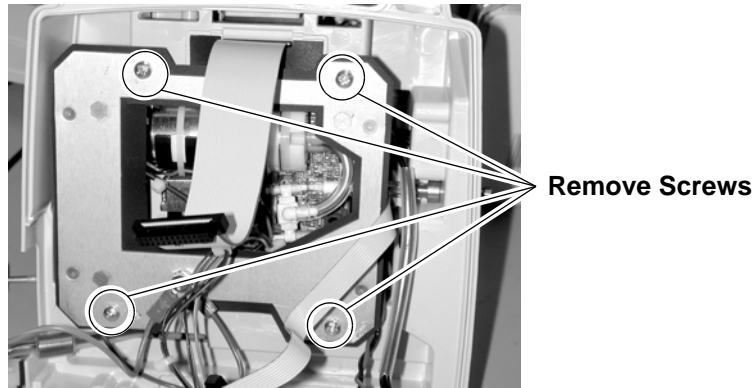

Figure 7-54: Remove Four Screws (Chassis)

2. Slide the chassis out of the rear housing and pull the NIBP fitting from the opening on the right side of the rear housing. Keep temp and SpO₂ cables (temp units) to the right.
 3. Remove the ground wire from **JP1**.
 4. Remove the harness from **CN1**.
 5. Flip the chassis up with the power supply facing up.
 6. Loosen the four (4) screws (pn 40496B001) that are contained with the four (4) #6 cup washers (pn 42499B001). Lift the power supply PCB (pn 86517C001) up and remove the four cup washers that lie beneath the power supply.
 7. Remove the cable assembly (pn 90927A002) from **CN2**.
 8. Replace power supply.
 9. Place the four (4) cup washers onto the existing standoffs.
 10. Align and place the power supply PCB on top of the cup washers. Using the four (4) screws (pn 40496B004), place each screw through the cup washer and place through each hole on power supply PCB. Tighten down with a torque of 5 in. lbs.
- NOTE:** **J5** header of the power supply should be the same as the NIBP fitting.
11. Plug power supply cable (pn 90927A002) into power supply at **J5**.
 12. Reassemble in reverse order.

Reassemble monitor and follow “Completion of Service” procedure at the end of this section.

Completion of Service

1. Verify all connections are secure.
2. Reconnect the battery as described in “Battery Removal/ Replacement” in Section 5.
3. Perform the functional tests in “Functional and Safety Testing” in Section 5.
4. Perform the electrical safety tests as described in “Electrical Safety Tests” in Section 5.

Section 8 — Troubleshooting

Troubleshooting Guide

| Symptom | Problem | Solution |
|-------------------------------------|--|---|
| Unit won't power up | <ul style="list-style-type: none"> Battery is discharged No AC power at outlet Main power fuse is blown Poor keypad cable connect Bad keypad switch Bad Main Board | Connect AC power cord Use alternate outlet Replace power fuse(s) by the AC input Reposition ribbon cable into Main Board Replace keypad membrane Replace Main Board and software |
| Monitor shuts off | <ul style="list-style-type: none"> Automatic shutoff after 30min. Drained battery Bad software Bad Main Board | Press the ON/OFF key Connect to AC power Update software Replace Main Board and reprogram |
| Functions not available | <ul style="list-style-type: none"> Default settings wrong Incorrect software Degraded software | Return to factory default settings Update software Replace software |
| LCD display blank (LEDs functional) | <ul style="list-style-type: none"> Contrast is misadjusted Bad LCD Board connection Bad LCD Board | Adjust <i>CONTRAST</i> in the <i>CONFIGURATION</i> menu Check pins and reconnect Replace LCD Board |
| Leaks in NIBP system | <ul style="list-style-type: none"> Defective cuff Defective hose Damaged/loose NIBP fitting Stripped insulator Leaky pneumatics & pump | Replace cuff Replace hose Replace/tighten Quick-Connect fitting Replace nylon insulator and O-ring Replace NIBP mechanical assembly |
| Fails performance test | <ul style="list-style-type: none"> Leaks in NIBP system Poor calibration Defective pump or valves Bad transducer | See above Recalibrate NIBP Replace NIBP mechanical assembly Replace NIBP mechanical assembly |
| NIBP not functioning | <ul style="list-style-type: none"> NIBP module turned off Bad NIBP switch Pump not running Failed pump motor Bad Main Board Bad NIBP Board | Turn on NIBP in the <i>CONFIGURATION</i> menu or ensure <i>1020</i> is selected for the <i>NIBP</i> setting in <i>BOARD SETUPS</i> in the service menu. Check pump wires to NIBP Board Check pins on NIBP Board & reconnect Replace pump Replace Main Board and software Replace NIBP Board and software |

| Symptom | Problem | Solution |
|---|--|---|
| Temperature not functioning | <ul style="list-style-type: none"> • Temperature module turned off • Temperature source not selected correctly. • Wrong Isolation Well or probe used • Bad probe • Temperature board disconnected • Bad Temperature Board • Bad Main Board/Temperature Cable | <p>Turn on Temperature in the <i>CONFIGURATION</i> menu or select <i>FSTMP</i> or <i>TURBO</i> for the <i>TEMP</i> setting in <i>BOARD SETUPS</i> in the service menu.</p> <p>Select correct source with the <i>ORAL/AXILLARY</i> key.</p> <p>Ensure correct well or probe is used: blue for oral and axillary, red for rectal.</p> <p>Replace probe.</p> <p>Reconnect Temperature board</p> <p>Replace Temperature Board</p> <p>Replace Main Board/Temperature Cable</p> |
| SpO ₂ not functioning. | <ul style="list-style-type: none"> • Using incorrect sensor. • SpO₂ module turned off • <i>LINE FREQ</i> is set incorrectly. (DOX only) • Bad sensor • SpO₂ board disconnected • Bad SpO₂ board • Bad Main Board/SpO₂ Cable | <p>Verify the correct sensor is used for the monitor</p> <p>Turn on SpO₂ in the <i>CONFIGURATION</i> menu or ensure the proper setting is selected for the <i>SPO2</i> setting in <i>BOARD SETUPS</i> in the service menu. <i>DOX</i> should be set for 506DN3 series monitors and <i>NCOR</i> should be set for 506LN3 series monitors.</p> <p>Verify that <i>LINE FREQ</i> is set correctly in <i>DEFAULT SETUPS</i> in the service menu.</p> <p>Replace sensor.</p> <p>Reconnect SpO₂ board</p> <p>Replace SpO₂ board</p> <p>Replace Main Board/SpO₂ Cable</p> |
| Unit intermittently missing blood pressure measurements | <ul style="list-style-type: none"> • Cuff size changed • Wrong cuff size or poor/loose cuff placement • Poor connection of NIBP module • Incorrect Patient Size selected | <p>Unit adapts to cuff size on next attempt</p> <p>Check cuff selection and placement</p> <p>Check pins and clean connection of the NIBP module to the Main Board or replace module/board if necessary.</p> <p>Change patient size</p> |
| No sound from speaker | <ul style="list-style-type: none"> • Speaker wire disconnected • Speaker wire broken • Bad Main Board | <p>Reconnect</p> <p>Replace speaker</p> <p>Replace Main Board</p> |
| No communications | <ul style="list-style-type: none"> • Serial settings not correct • Bad serial cable (external) • Bad Main Board | <p>Check MENU settings</p> <p>Replace external serial cable</p> <p>Replace Main Board</p> |
| Printer doesn't print | <ul style="list-style-type: none"> • Not set to internal printer • Printer connection is disconnected or loose • Bad printer • Bad Printer PCB • Bad Main Board/Printer Cable | <p>Set the <i>Output to Printer</i> in the <i>PRINTER SETUP</i> menu</p> <p>Reconnect J4 on the Main PCB and/or J1 on the Printer PCB</p> <p>Replace printer</p> <p>Replace Printer PCB</p> <p>Replace Main Board/Printer Cable</p> |

Section 9 — Drawings and Schematics

List of Drawings

| Assembly Parts Lists | Title | Drawing Number |
|----------------------|---|----------------|
| | Final Assembly—506DN3 | 93975A001 |
| | Final Assembly—506DNP3 | 93975A002 |
| | Final Assembly—506DNT3 | 93975A003 |
| | Final Assembly—506DNTP3 | 93975A004 |
| | Final Assembly—506LN3 | 93975A005 |
| | Final Assembly—506LNP3 | 93975A006 |
| | Final Assembly—506LNT3 | 93975A007 |
| | Final Assembly—506LNT3 | 93975A008 |
| | Final Assembly—506DNV3 | 93975A009 |
| | Final Assembly—506DNVP3 | 93975A010 |
| | Final Assembly—506LNV3 | 93975A011 |
| | Final Assembly—506LNV3 | 93975A012 |
| | Final Assembly—506N3 | 93975A020 |
| | Final Assembly—506NP3 | 93975A021 |
| | Final Assembly—506NT3 | 93975A022 |
| | Final Assembly—506NTP3 | 93975A023 |
| | Final Assembly—506NV3 | 93975A024 |
| | Final Assembly—506NVP3 | 93975A025 |
| | Base Assembly—Non-Temperature 506DN(P)3, 506LN(P)3 | 93949A001 |
| | Base Assembly—Temperature 506DNT(P)3, 506LNT(P)3, 506DNV(P)3, 506LNV(P)3 | 93949A002 |
| | Base Assembly—NIBP Only 506N(P)3 | 93949A003 |
| | Base Assembly—NIBP/TEMP 506NT(P)3, 506NV(P)3 | 93949A004 |
| | Front Bezel—Non-Temperature 506DN(P)3, 506LN(P)3 | 92505A001 |
| | Front Bezel—Temperature 506DNT(P)3, 506LNT(P)3, 506DNV(P)3, 506LNV(P)3 | 92505A002 |
| | Front Bezel—NIBP Only 506N(P)3 | 92505A003 |
| | Front Bezel—NIBP/TEMP 506NT(P)3, 506NV(P)3 | 92505A004 |

| | | |
|-------------------------|------------------------------------|---------------------------|
| | Rear Housing Assembly | 93249A001 |
| | Chassis Assembly | 95746A001 |
| | NIBP Module Final Assembly | 93947A003 |
| | NIBP Pneumatics Assembly | 95597A002 |
| | PCB Assembly | 90232A001 |
| | Printer Assembly | 95745A001 |
| PCB Drawing List | | |
| | NIBP PCB | 91325A003 |
| | NIBP PCB Schematic | 91325S003 |
| | Main Board PCB | 91384A001 A002 A003 |
| | Main Board Schematic | 91384S001 S002 S003 |
| | FasTemp Isolation PCB | 91386A001 |
| | FasTemp Isolation PCB Schematic | 91386S001 |
| | Nellcor Carrier PCB | 91387A001 |
| | Nellcor Carrier PCB Schematic | 91387S001 |
| | Display PCB | 91388A001 |
| | Display PCB Schematic | 91388S001 |
| | Printer Interface PCB | 91389A002 |
| | Printer Interface PCB Schematic | 91389S002 |
| | DOX SpO ₂ PCB | 91391A001 |
| | DOX SpO ₂ PCB Schematic | 91391S001 |
| | TurboTemp PCB | 91403A001 |
| | TurboTemp PCB Schematic | 91403S001 |

Final Assemblies

506DN3 93975A001 AY FINAL 506DN3 DOX/SPO2

| Item # | CSI Part # | Description |
|---------------|-------------------|------------------------------------|
| 01 | 93949A001 | 506N3 BASE ASSEMBLY NON-TEMP |
| 02 | 91391A001 | PCB ASSEMBLY DIGITAL SPO2 |
| 03 | 40995B005 | P.H.M.S. 4-40X.25 SEMS |
| 04 | 42616B001 | INSULATOR TEMPERATURE BOARD |
| 05 | 42476B001 | STANDOFF M-F 4-40X.250 |
| 06 | 42597B001 | DOX CONN LOCK |
| 07 | 45170C001 | MOD SIDE PANEL 506 GEMINI |
| 09 | 45172B001 | COVER PNTR BAY 506N3 |
| 10 | 46519B001 | LABEL CSI DOX CLEAR |
| 11 | 46162B004 | LABEL BAR CODE |
| 12 | 46426B005 | LABEL HARDWARE REVISION 5 |
| 13 | 95763A001 | LABEL SET 506N3 ENGLISH |
| 14 | 80518B001 | BATT 7.2AH 6V |
| 16 | 40994B001 | ADHESIVE RTV3145 CL |
| 17 | 40193B002 | P.H.M.S. #4-40 X .250" COATED GREY |
| 25 | 41891B004 | DUST COVER, CLEAR, DB9P |

506DNP3 93975A002 AY FINAL 506DNP3 DOX/SPO2/PRNT

| Item # | CSI Part # | Description |
|---------------|-------------------|------------------------------------|
| 01 | 93949A001 | 506N3 BASE ASSEMBLY NON-TEMP |
| 02 | 91391A001 | PCB ASSEMBLY DIGITAL SPO2 |
| 03 | 40995B005 | P.H.M.S. 4-40X.25 SEMS |
| 04 | 42616B001 | INSULATOR TEMPERATURE BOARD |
| 05 | 42476B001 | STANDOFF M-F 4-40X.250 |
| 06 | 42597B001 | DOX CONN LOCK |
| 07 | 45170C001 | MOD SIDE PANEL 506 GEMINI |
| 09 | 95745A001 | PRINTER ASSEMBLY 506N3 |
| 10 | 46519B001 | LABEL CSI DOX CLEAR |
| 11 | 46162B004 | LABEL BAR CODE |
| 12 | 46426B005 | LABEL HARDWARE REVISION 5 |
| 13 | 95763A001 | LABEL SET 506N3 ENGLISH |
| 14 | 80518B001 | BATT 7.2AH 6V |
| 16 | 40994B001 | ADHESIVE RTV3145 CL |
| 17 | 40193B002 | P.H.M.S. #4-40 X .250" COATED GREY |
| 25 | 41891B004 | DUST COVER, CLEAR, DB9P |

506DNT3 93975A003 AY FINAL 506DNT3 DOX/SPO2/TEMP

| Item # | CSI Part # | Description |
|---------------|-------------------|------------------------------------|
| 01 | 93949A002 | 506N3 BASE ASSEMBLY TEMP |
| 02 | 91391A001 | PCB ASSEMBLY DIGITAL SPO2 |
| 03 | 40995B005 | P.H.M.S. 4-40X.25 SEMS |
| 04 | 42616B001 | INSULATOR TEMPERATURE BOARD |
| 05 | 42476B001 | STANDOFF M-F 4-40X.250 |
| 06 | 42597B001 | DOX CONN LOCK |
| 07 | 45171C001 | MOD SIDE PANEL TEMP 506 GEMINI |
| 08 | 41973B002 | FASTEMP SILICONE CONTACT |
| 09 | 83460B001 | FASTEMP OEM PCB ASSEMBLY |
| 10 | 83466B002 | FLEX CIRCUIT 4POS OPP CONTACT |
| 11 | 90933A001 | CBL AY TEMP RS232 |
| 12 | 40283B001 | WASHER FLAT #4 NY .062 |
| 13 | 91386A001 | AY FASTEMP ISOLATION BRD |
| 15 | 45172B001 | COVER PNTR BAY 506N3 |
| 16 | 46519B001 | LABEL CSI DOX CLEAR |
| 17 | 46162B004 | LABEL BAR CODE |
| 18 | 46426B005 | LABEL HARDWARE REVISION 5 |
| 19 | 95763A001 | LABEL SET 506N3 ENGLISH |
| 20 | 80518B001 | BATT 7.2AH 6V |
| 22 | 40994B001 | ADHESIVE RTV3145 CL |
| 23 | 42619B001 | FOAM PAD .25 X 1.00 |
| 24 | 40193B002 | P.H.M.S. #4-40 X .250" COATED GREY |
| 25 | 41891B004 | DUST COVER, CLEAR, DB9P |
| 26 | 42655B001 | WASHER, FILM, INSULATING |

506DNTP3 93975A004 AY FINAL 506DNT3 DOX/SPO2/T/P

| Item # | CSI Part # | Description |
|--------|------------|------------------------------------|
| 01 | 93949A002 | 506N3 BASE ASSEMBLY TEMP |
| 02 | 91391A001 | PCB ASSEMBLY DIGITAL SPO2 |
| 03 | 40995B005 | P.H.M.S. 4-40X.25 SEMS |
| 04 | 42616B001 | INSULATOR TEMPERATURE BOARD |
| 05 | 42476B001 | STANDOFF M-F 4-40X.250 |
| 06 | 42597B001 | DOX CONN LOCK |
| 07 | 45171C001 | MOD SIDE PANEL TEMP 506 GEMINI |
| 08 | 41973B002 | FASTEMP SILICONE CONTACT |
| 09 | 83460B001 | FASTEMP OEM PCB ASSEMBLY |
| 10 | 83466B002 | FLEX CIRCUIT 4POS OPP CONTACT |
| 11 | 90933A001 | CBL AY TEMP RS232 |
| 12 | 40283B001 | WASHER FLAT #4 NY .062 |
| 13 | 91386A001 | AY FASTEMP ISOLATION BRD |
| 15 | 95745A001 | PRINTER ASSEMBLY 506N3 |
| 16 | 46519B001 | LABEL CSI DOX CLEAR |
| 17 | 46162B004 | LABEL BAR CODE |
| 18 | 46426B005 | LABEL HARDWARE REVISION 5 |
| 19 | 95763A001 | LABEL SET 506N3 ENGLISH |
| 20 | 80518B001 | BATT 7.2AH 6V |
| 22 | 40994B001 | ADHESIVE RTV3145 CL |
| 23 | 42619B001 | FOAM PAD .25 X 1.00 |
| 24 | 40193B002 | P.H.M.S. #4-40 X .250" COATED GREY |
| 25 | 41891B004 | DUST COVER, CLEAR, DB9P |
| 26 | 42655B001 | WASHER, FILM, INSULATING |

506LN3 93975A005 AY FINAL 506LN3 NELLCOR/SPO2

| Item # | CSI Part # | Description |
|--------|------------|------------------------------------|
| 01 | 93949A001 | 506N3 BASE ASSEMBLY NON-TEMP |
| 02 | 42255B004 | STANDOFF M-F 2-56 .188D x.281L |
| 03 | 91387A001 | PCB AY NELLCOR CARRIER |
| 04 | 40008B005 | NUT HEX 2-56 PL |
| 05 | 83459B002 | NELLCOR NELL-1 SPO2 PCB ASMBLY |
| 06 | 41258B003 | P.H.M.S. #2-56X.188 LGSEMS |
| 07 | 40995B005 | P.H.M.S. 4-40X.25 SEMS |
| 08 | 42616B001 | INSULATOR TEMPERATURE BOARD |
| 09 | 42476B001 | STANDOFF M-F 4-40X.250 |
| 10 | 45170B001 | SIDE PANEL 506N3 |
| 12 | 45172B001 | COVER PNTR BAY 506 GEMINI |
| 13 | 46029B001 | LABEL 1" NELLCOR OXIMAX WORKS |
| 14 | 46162B004 | LABEL BAR CODE |
| 15 | 46426B005 | LABEL HARDWARE REVISION 5 |
| 16 | 95763A001 | LABEL SET 506N3 ENGLISH |
| 17 | 80518B001 | BATT 7.2AH 6V |
| 19 | 40994B001 | ADHESIVE RTV3145 CL |
| 20 | 40193B002 | P.H.M.S. #4-40 X .250" COATED GREY |
| 25 | 41891B004 | DUST COVER, CLEAR, DB9P |

506LNP3 93975A006 AY FINAL 506LNP3 NELLCOR

| Item # | CSI Part # | Description |
|---------------|-------------------|------------------------------------|
| 01 | 93949A001 | 506N3 BASE ASSEMBLY NON-TEMP |
| 02 | 42255B004 | STANDOFF M-F 2-56 .188D x.281L |
| 03 | 91387A001 | PCB AY NELLCOR CARRIER |
| 04 | 40008B005 | NUT HEX 2-56 PL |
| 05 | 83459B001 | NELLCOR NELL-1 SPO2 PCB ASMBLY |
| 06 | 41258B003 | P.H.M.S. #2-56X.188 LGSEMS |
| 07 | 40995B005 | P.H.M.S. 4-40X.25 SEMS |
| 08 | 42616B001 | INSULATOR TEMPERATURE BOARD |
| 09 | 42476B001 | STANDOFF M-F 4-40X.250 |
| 10 | 45170B001 | SIDE PANEL 506N3 |
| 12 | 95745A001 | PRINTER ASSEMBLY 506N3 |
| 13 | 46029B001 | LABEL 1" NELLCOR OXIMAX WORKS |
| 14 | 46162B004 | LABEL BAR CODE |
| 15 | 46426B005 | LABEL HARDWARE REVISION 5 |
| 16 | 95763A001 | LABEL SET 506N3 ENGLISH |
| 17 | 80518B001 | BATT 7.2AH 6V |
| 19 | 40994B001 | ADHESIVE RTV3145 CL |
| 20 | 40193B002 | P.H.M.S. #4-40 X .250" COATED GREY |
| 25 | 41891B004 | DUST COVER, CLEAR, DB9P |

506LNT3 93975A007 AY FINAL 506LNT3 NELLCOR

| Item # | CSI Part # | Description |
|---------------|-------------------|------------------------------------|
| 01 | 93949A002 | 506N3 BASE ASSEMBLY TEMP |
| 02 | 42255B004 | STANDOFF M-F 2-56 .188D x.281L |
| 03 | 91387A001 | PCB AY NELLCOR CARRIER |
| 04 | 40008B005 | NUT HEX 2-56 PL |
| 05 | 83459B002 | NELLCOR NELL-1 SPO2 PCB ASMBLY |
| 06 | 41258B003 | P.H.M.S. #2-56X.188 LGSEMS |
| 07 | 40995B005 | P.H.M.S. 4-40X.25 SEMS |
| 08 | 42616B001 | INSULATOR TEMPERATURE BOARD |
| 09 | 42476B001 | STANDOFF M-F 4-40X.250 |
| 10 | 83460B001 | FASTEMP OEM PCB AY |
| 11 | 83466B002 | FLEX CIRCUIT 4POS OPP CONTACT |
| 12 | 90933A001 | CBL AY TEMP RS232 |
| 13 | 45171B001 | SIDE PANEL TMP 506N3 |
| 14 | 41973B002 | FASTEMP SILICONE CONTACT |
| 15 | 40283B001 | WASHER FLAT #4 NY .062 |
| 16 | 91386A001 | AY FASTEMP ISOLATION BRD |
| 18 | 45172B001 | COVER PNTR BAY 506 GEMINI |
| 19 | 46029B001 | LABEL 1" NELLCOR OXIMAX WORKS |
| 20 | 46162B004 | LABEL BAR CODE |
| 21 | 46426B005 | LABEL HARDWARE REVISION 5 |
| 22 | 95763A001 | LABEL SET 506N3 ENGLISH |
| 23 | 80518B001 | BATT 7.2AH 6V |
| 25 | 40994B001 | ADHESIVE RTV3145 CL |
| 26 | 42619B001 | FOAM PAD .25 X 1.00 |
| 27 | 40193B002 | P.H.M.S. #4-40 X .250" COATED GREY |
| 28 | 41891B004 | DUST COVER, CLEAR, DB9P |
| 29 | 42655B001 | WASHER, FILM, INSULATING |

506LNTP3 93975A008 AY FINAL 506LNT3 NELLCOR

| Item # | CSI Part # | Description |
|---------------|-------------------|------------------------------------|
| 01 | 93949A002 | 506N3 BASE ASSEMBLY TEMP |
| 02 | 42255B004 | STANDOFF M-F 2-56 .188D x.281L |
| 03 | 91387A001 | PCB AY NELLCOR CARRIER |
| 04 | 40008B005 | NUT HEX 2-56 PL |
| 05 | 83459B002 | NELLCOR NELL-1 SPO2 PCB ASMBLY |
| 06 | 41258B003 | P.H.M.S. #2-56X.188 LGSEMS |
| 07 | 40995B005 | P.H.M.S. 4-40X.25 SEMS |
| 08 | 42616B001 | INSULATOR TEMPERATURE BOARD |
| 09 | 42476B001 | STANDOFF M-F 4-40X.250 |
| 10 | 83460B001 | FASTEMP OEM PCB AY |
| 11 | 83466B002 | FLEX CIRCUIT 4POS OPP CONTACT |
| 12 | 90933A001 | CBL AY TEMP RS232 |
| 13 | 45171B001 | SIDE PANEL TMP 506N3 |
| 14 | 41973B002 | FASTEMP SILICONE CONTACT |
| 15 | 40283B001 | WASHER FLAT #4 NY .062 |
| 16 | 91386A001 | AY FASTEMP ISOLATION BRD |
| 18 | 95745A001 | PRINTER ASSEMBLY 506N3 |
| 19 | 46029B001 | LABEL 1" NELLCOR OXIMAX WORKS |
| 20 | 46162B004 | LABEL BAR CODE |
| 21 | 46426B006 | LABEL HARDWARE REVISION 6 |
| 22 | 95763A001 | LABEL SET 506N3 ENGLISH |
| 23 | 80518B001 | BATT 7.2AH 6V |
| 25 | 40994B001 | ADHESIVE RTV3145 CL |
| 26 | 42619B001 | FOAM PAD .25 X 1.00 |
| 27 | 40193B002 | P.H.M.S. #4-40 X .250" COATED GREY |
| 28 | 41891B004 | DUST COVER, CLEAR, DB9P |
| 29 | 42655B001 | WASHER, FILM, INSULATING |

506DNV3 93975A009 DOX ALARIS TEMP

| Item # | CSI Part # | Description |
|--------|------------|------------------------------------|
| 01 | 93949A002 | 506N3 BASE ASSEMBLY TEMP |
| 02 | 91391A001 | PCB ASSEMBLY DIGITAL SPO2 |
| 03 | 40995B005 | P.H.M.S. 4-40X.25 SEMS |
| 04 | 42616B001 | INSULATOR TEMPERATURE BOARD |
| 05 | 42476B001 | STANDOFF M-F 4-40X.250 |
| 06 | 42597B001 | DOX CONN LOCK |
| 07 | 45196B002 | SIDE PNL TEMP ALARIS DOX |
| 15 | 45172B001 | COVER PNTR BAY 506N3 |
| 16 | 46519B001 | LABEL CSI DOX CLEAR |
| 17 | 46162B004 | LABEL BAR CODE |
| 18 | 46426B001 | LABEL HARDWARE REVISION 1 |
| 19 | 95763A001 | LABEL SET 506N3 ENGLISH |
| 20 | 80518B001 | BATT 7.2AH 6V |
| 24 | 40193B002 | P.H.M.S. #4-40 X .250" COATED GREY |
| 25 | 41891B004 | DUST COVER, CLEAR, DB9P |
| 27 | 45197B001 | PROBE COVER HOLDER |
| 28 | 91403A001 | AY PCB ALARIS TURBO TEMP |
| 29 | 40995B009 | P.H.M.S. 4-40 X .625 SEMS |

506DNVP3 93975A010 DOX ALARIS TEMP W/PRINTER

| Item # | CSI Part # | Description |
|--------|------------|------------------------------------|
| 01 | 93949A002 | 506N3 BASE ASSEMBLY TEMP |
| 02 | 91391A001 | PCB ASSEMBLY DIGITAL SPO2 |
| 03 | 40995B005 | P.H.M.S. 4-40X.25 SEMS |
| 04 | 42616B001 | INSULATOR TEMPERATURE BOARD |
| 05 | 42476B001 | STANDOFF M-F 4-40X.250 |
| 06 | 42597B001 | DOX CONN LOCK |
| 07 | 45196B002 | SIDE PNL TEMP ALARIS DOX |
| 15 | 95745A001 | PRINTER ASSEMBLY 506N3 |
| 16 | 46519B001 | LABEL CSI DOX CLEAR |
| 17 | 46162B004 | LABEL BAR CODE |
| 18 | 46426B001 | LABEL HARDWARE REVISION 1 |
| 19 | 95763A001 | LABEL SET 506N3 ENGLISH |
| 20 | 80518B001 | BATT 7.2AH 6V |
| 24 | 40193B002 | P.H.M.S. #4-40 X .250" COATED GREY |
| 25 | 41891B004 | DUST COVER, CLEAR, DB9P |
| 27 | 45197B001 | PROBE COVER HOLDER |
| 28 | 91403A001 | AY PCB ALARIS TURBO TEMP |
| 29 | 40995B009 | P.H.M.S. 4-40 X .625 SEMS |

506LNV3 93975A011 NELLCOR ALARIS TEMP

| Item # | CSI Part # | Description |
|--------|------------|------------------------------------|
| 01 | 93949A002 | 506N3 BASE ASSEMBLY TEMP |
| 02 | 42255B004 | STANDOFF M-F 2-56 .188D X.281L |
| 03 | 91387A001 | PCB AY NELLCOR CARRIER |
| 04 | 40008B005 | NUT HEX 2-56 PL |
| 05 | 83459B001 | NELLCOR NELL-1 SPO2 PCB ASMBLY |
| 06 | 41258B003 | P.H.M.S. #2-56X.188 LGSEMS |
| 07 | 40995B005 | P.H.M.S. 4-40X.25 SEMS |
| 08 | 42616B001 | INSULATOR TEMPERATURE BOARD |
| 09 | 42476B001 | STANDOFF M-F 4-40X.250 |
| 13 | 45196B001 | SIDE PNL TEMP ALARIS NELLCOR |
| 18 | 45172B001 | COVER PNTR BAY 506N3 |
| 19 | 46029B001 | LABEL 1" NELLCOR OXIMAX WORKS |
| 20 | 46162B004 | LABEL BAR CODE |
| 21 | 46426B001 | LABEL HARDWARE REVISION 1 |
| 22 | 95763A001 | LABEL SET 506N3 ENGLISH |
| 23 | 80518B001 | BATT 7.2AH 6V |
| 27 | 40193B002 | P.H.M.S. #4-40 X .250" COATED GREY |
| 28 | 41891B004 | DUST COVER, CLEAR, DB9P |
| 30 | 45197B001 | PROBE COVER HOLDER |
| 31 | 91403A001 | AY PCB ALARIS TURBO TEMP |
| 32 | 40995B009 | P.H.M.S. 4-40 X .625 SEMS |

506LNVP3 93975A012 NELLCOR ALARIS TEMP PRINTER

| Item # | CSI Part # | Description |
|--------|------------|------------------------------------|
| 01 | 93949A002 | 506N3 BASE ASSEMBLY TEMP |
| 02 | 42255B004 | STANDOFF M-F 2-56 .188D X.281L |
| 03 | 91387A001 | PCB AY NELLCOR CARRIER |
| 04 | 40008B005 | NUT HEX 2-56 PL |
| 05 | 83459B001 | NELLCOR NELL-1 SPO2 PCB ASMBLY |
| 06 | 41258B003 | P.H.M.S. #2-56X.188 LGSEMS |
| 07 | 40995B005 | P.H.M.S. 4-40X.25 SEMS |
| 08 | 42616B001 | INSULATOR TEMPERATURE BOARD |
| 09 | 42476B001 | STANDOFF M-F 4-40X.250 |
| 13 | 45196B001 | SIDE PNL TEMP ALARIS NELLCOM |
| 18 | 95745A001 | PRINTER ASSEMBLY 506N3 |
| 19 | 46029B001 | LABEL 1" NELLCOR OXIMAX WORKS |
| 20 | 46162B004 | LABEL BAR CODE |
| 21 | 46426B001 | LABEL HARDWARE REVISION 1 |
| 22 | 95763A001 | LABEL SET 506N3 ENGLISH |
| 23 | 80518B001 | BATT 7.2AH 6V |
| 27 | 40193B002 | P.H.M.S. #4-40 X .250" COATED GREY |
| 28 | 41891B004 | DUST COVER, CLEAR, DB9P |
| 30 | 45197B001 | PROBE COVER HOLDER |
| 31 | 91403A001 | AY PCB ALARIS TURBO TEMP |
| 32 | 40995B009 | P.H.M.S. 4-40 X .625 SEMS |

506N3 93975A020 506N3 NIBP ONLY MONITOR

| Item # | CSI Part # | Description |
|---------------|-------------------|------------------------------------|
| 01 | 93949A003 | BASE ASSEMBLY NIBP ONLY |
| 07 | 45170B001 | SIDE PANEL 506N3 |
| 09 | 45172B001 | COVER PNTR BAY 506N3 |
| 11 | 46162B004 | LABEL BAR CODE |
| 12 | 46426B001 | LABEL HARDWARE REVISION 1 |
| 13 | 95763A001 | LABEL SET 506N3 ENGLISH |
| 14 | 80518B001 | BATT 7.2AH 6V |
| 17 | 40193B002 | P.H.M.S. #4-40 X .250" COATED GREY |
| 25 | 41891B004 | DUST COVER, CLEAR, DB9P |
| 27 | 42670B001 | COVER PLATE, O2 SENSOR OPENING |

506NP3 93975A021 506NP3 NIBP ONLY PRINTER MON

| Item # | CSI Part # | Description |
|---------------|-------------------|------------------------------------|
| 01 | 93949A003 | BASE ASSEMBLY NIBP ONLY |
| 07 | 45170B001 | SIDE PANEL 506N3 |
| 09 | 95745A001 | PRINTER ASSEMBLY 506N3 |
| 11 | 46162B004 | LABEL BAR CODE |
| 12 | 46426B001 | LABEL HARDWARE REVISION 1 |
| 13 | 95763A001 | LABEL SET 506N3 ENGLISH |
| 14 | 80518B001 | BATT 7.2AH 6V |
| 17 | 40193B002 | P.H.M.S. #4-40 X .250" COATED GREY |
| 25 | 41891B004 | DUST COVER, CLEAR, DB9P |
| 27 | 42670B001 | COVER PLATE, O2 SENSOR OPENING |

506NT3 93975A022 506NT3 NIBP ONLY FAST TEMP MON

| Item # | CSI Part # | Description |
|--------|------------|------------------------------------|
| 01 | 93949A004 | BASE ASSEMBLY NIBP/TEMP |
| 03 | 40995B005 | P.H.M.S. 4-40X.25 SEMS |
| 04 | 42616B001 | INSULATOR TEMPERATURE BOARD |
| 05 | 42476B003 | STANDOFF M-F 4-40X.312 |
| 07 | 45171B001 | SIDE PANEL TMP 506N3 |
| 08 | 41973B002 | FASTEMP SILICONE CONTACT |
| 09 | 83460B001 | FASTEMP OEM PCB ASSEMBLY |
| 10 | 83466B002 | FLEX CIRCUIT 4POS OPP CONTACT |
| 11 | 90933A001 | CBL AY TEMP RS232 |
| 12 | 40283B001 | WASHER FLAT #4 NY .062 |
| 13 | 91386A001 | AY FASTEMP ISOLATION BRD |
| 15 | 45172B001 | COVER PNTR BAY 506N3 |
| 17 | 46162B004 | LABEL BAR CODE |
| 18 | 46426B001 | LABEL HARDWARE REVISION 1 |
| 19 | 95763A001 | LABEL SET 506N3 ENGLISH |
| 20 | 80518B001 | BATT 7.2AH 6V |
| 22 | 40994B001 | ADHESIVE RTV3145 CL |
| 23 | 42619B001 | FOAM PAD .25 X 1.00 |
| 24 | 40193B002 | P.H.M.S. #4-40 X .250" COATED GREY |
| 25 | 41891B004 | DUST COVER, CLEAR, DB9P |
| 26 | 42655B001 | WASHER, FILM, INSULATING |
| 27 | 42670B001 | COVER PLATE, O2 SENSOR OPENING |

506NTP3 93975A023 506NTP3 NIBP ONLY FAST TEMP PR

| Item # | CSI Part # | Description |
|--------|------------|------------------------------------|
| 01 | 93949A004 | BASE ASSEMBLY NIBP/TEMP |
| 03 | 40995B005 | P.H.M.S. 4-40X.25 SEMS |
| 04 | 42616B001 | INSULATOR TEMPERATUER BOARD |
| 05 | 42476B003 | STANDOFF M-F 4-40X.312 |
| 07 | 45171B001 | SIDE PANEL TMP 506N3 |
| 08 | 41973B002 | FASTEMP SILICONE CONTACT |
| 09 | 83460B001 | FASTEMP OEM PCB ASSEMBLY |
| 10 | 83466B002 | FLEX CIRCUIT 4POS OPP CONTACT |
| 11 | 90933A001 | CBL AY TEMP RS232 |
| 12 | 40283B001 | WASHER FLAT #4 NY .062 |
| 13 | 91386A001 | AY FASTEMP ISOLATION BRD |
| 15 | 95745A001 | PRINTER ASSEMBLY 506N3 |
| 17 | 46162B004 | LABEL BAR CODE |
| 18 | 46426B001 | LABEL HARDWARE REVISION 1 |
| 19 | 95763A001 | LABEL SET 506N3 ENGLISH |
| 20 | 80518B001 | BATT 7.2AH 6V |
| 22 | 40994B001 | ADHESIVE RTV3145 CL |
| 23 | 42619B001 | FOAM PAD .25 X 1.00 |
| 24 | 40193B002 | P.H.M.S. #4-40 X .250" COATED GREY |
| 25 | 41891B004 | DUST COVER, CLEAR, DB9P |
| 26 | 42655B001 | WASHER, FILM, INSULATING |
| 27 | 42670B001 | COVER PLATE, O2 SENSOR OPENING |

506NV3 93975A024 NIBP ONLY ALARIS MONITOR

| Item # | CSI Part # | Description |
|--------|------------|------------------------------------|
| 01 | 93949A004 | BASE ASSEMBLY NIBP/TEMP |
| 15 | 45172B001 | COVER PNTR BAY 506N3 |
| 17 | 46162B004 | LABEL BAR CODE |
| 18 | 46426B001 | LABEL HARWARE REVISION 1 |
| 19 | 95763A001 | LABEL SET 506N3 ENGLISH |
| 20 | 80518B001 | BATT 7.2AH 6V |
| 24 | 40193B002 | P.H.M.S. #4-40 X .250" COATED GREY |
| 25 | 41891B004 | DUST COVER, CLEAR, DB9P |
| 27 | 42670B001 | COVER PLATE, O2 SENSOR OPENING |
| 29 | 45196B001 | SIDE PNL TEMP ALARIS NELLCOR |
| 30 | 45197B001 | PROBE COVER HOLDER |
| 31 | 91403A001 | AY PCB ALARIS TURBO TEMP |
| 32 | 40995B009 | P.H.M.S. 4-40 X .625 SEMS |

506NVP3 93975A025 NIBP PRINTER ONLY ALARIS

| Item # | CSI Part # | Description |
|--------|------------|------------------------------------|
| 01 | 93949A004 | BASE ASSEMBLY NIBP/TEMP |
| 15 | 95745A001 | PRINTER ASSEMBLY 506N3 |
| 17 | 46162B004 | LABEL BAR CODE |
| 18 | 46426B001 | LABEL HARDWARE REVISION 1 |
| 19 | 95763A001 | LABEL SET 506N3 ENGLISH |
| 20 | 80518B001 | BATT 7.2AH 6V |
| 24 | 40193B002 | P.H.M.S. #4-40 X .250" COATED GREY |
| 25 | 41891B004 | DUST COVER, CLEAR, DB9P |
| 27 | 42670B001 | COVER PLATE, O2 SENSOR OPENING |
| 29 | 45196B001 | SIDE PNL TEMP ALARIS NELLCOR |
| 30 | 45197B001 | PROBE COVER HOLDER |
| 31 | 91403A001 | AY PCB ALARIS TURBO TEMP |
| 32 | 40995B009 | P.H.M.S. 4-40 X .625 SEMS |

Base Assemblies

Without Temperature 93949A001 506N3 BASE ASSEMBLY NON-TEMP

| Item # | CSI Part # | Description |
|--------|------------|--------------------------------|
| 02 | 42624B001 | HEX NUT THIN 1/4-32 |
| 05 | 40195B005 | P.H.M.S. #6 X.875" COATED GREY |
| 06 | 92505A001 | ASSEMBLY BEZEL 506N3 NON-TEMP |
| 07 | 93249A001 | ASSEMBLY HOUSING REAR 506N3 |
| 08 | 95746A001 | ASSEMBLY CHASSIS 506N3 |
| 09 | 40496B001 | P.H.M.S. 6-32X.375 SEMS |
| 10 | 46021B008 | LABEL 506N3 BASE AY NON-TEMP |
| 11 | 46426B004 | LABEL HARDWARE REVISION 4 |
| 12 | 90930A001 | CBL AY SPO2 TO MAIN BRD |
| 13 | 41955B001 | FOAM TAPE 1.0 X 2.12 |

With Temperature 93949A002 506N3 BASE ASSEMBLY TEMP

| Item # | CSI Part # | Description |
|--------|------------|--------------------------------|
| 02 | 42624B001 | HEX NUT THIN 1/4-32 |
| 03 | 90931A001 | CBL TEMP TO MAIN BRD |
| 05 | 40195B005 | P.H.M.S. #6 X.875" COATED GREY |
| 06 | 92505A002 | ASSEMBLY BEZEL 506N3 TEMP |
| 07 | 93249A001 | ASSEMBLY HOUSING REAR 506N3 |
| 08 | 95746A001 | AY CHASSIS 506N3 |
| 09 | 40496B001 | P.H.M.S. 6-32X.375 SEMS |
| 10 | 46021B009 | LABEL 506N3 BASE AY TEMP |
| 11 | 46426B004 | LABEL HARDWARE REVISION 4 |
| 12 | 90930A001 | CBL AY SPO2 TO MAIN BRD |
| 13 | 41955B001 | FOAM TAPE 1.0 X 2.12 |

 NIBP Only 93949A003 BASE ASSEMBLY NIBP ONLY

| Item # | CSI Part # | Description |
|---------------|-------------------|------------------------------------|
| 02 | 42624B001 | HEX NUT THIN 1/4-32 |
| 05 | 40195B005 | P.H.M.S. #6-32 X .875" COATED GREY |
| 06 | 92505A003 | BEZEL ASSEMBLY NIBP ONLY |
| 07 | 93249A001 | ASSEMBLY HOUSING REAR 506N3 |
| 08 | 95746A001 | ASSEMBLY CHASSIS 506N3 |
| 09 | 40496B001 | P.H.M.S. 6-32X.375 SEMS |
| 10 | 46021B010 | LABEL BASE NON-TEMP, NO SPO2 |
| 11 | 46426B001 | LABEL HARDWARE REVISION 1 |

NIBP/TEMP 93949A004 BASE ASSEMBLY NIBP/TEMP

| Item # | CSI Part # | Description |
|---------------|-------------------|------------------------------------|
| 02 | 42624B001 | HEX NUT THIN 1/4-32 |
| 03 | 90931A001 | CBL TEMP TO MAIN BRD |
| 05 | 40195B005 | P.H.M.S. #6-32 X .875" COATED GREY |
| 06 | 92505A004 | BEZEL ASSEMBLY NIBP/TEMP |
| 07 | 93249A001 | ASSEMBLY HOUSING REAR 506N3 |
| 08 | 95746A001 | ASSEMBLY CHASSIS 506N3 |
| 09 | 40496B001 | P.H.M.S. 6-32X.375 SEMS |
| 10 | 46021B011 | LABEL BASE TEMP, NO SPO2 |
| 11 | 46426B001 | LABEL HARDWARE REVISION 1 |

Front Bezel

Non-Temperature 92505A001 ASSEMBLY BEZEL 506N3 NON-TEMP

| Item # | CSI Part # | Description |
|--------|------------|--------------------------------|
| 01 | 42623B001 | FOAM PAD .50 X .75 |
| 02 | 45168B001 | BEZEL 506N3 |
| 03 | 45163B001 | MEMBRANE SW 506N3 NON-TEMP |
| 04 | 90232A001 | AY MAIN AND DISPLAY BD 506N3 |
| 05 | 40995B005 | P.H.M.S. 4-40X.25 SEMS |
| 06 | 40086B002 | WASHER FLAT PL .125X.313 |
| 07 | 90932A001 | CABLE ASSEMBLY SPEAKER |
| 10 | 46021B004 | LABEL 506N3 BEZEL AY NON-TP ID |
| 11 | 46426B006 | LABEL HARDWARE REVISION 6 |

Temperature 92505A002 ASSEMBLY BEZEL 506N3 TEMP

| Item # | CSI Part # | Description |
|--------|------------|------------------------------|
| 01 | 42623B001 | FOAM PAD .50 X .75 |
| 02 | 45168B001 | BEZEL 506N3 |
| 03 | 45163B002 | MEMBRANE SW 506N3 TEMP |
| 04 | 90232A001 | AY MAIN AND DISPLAY BD 506N3 |
| 05 | 40995B005 | P.H.M.S. 4-40X.25 SEMS |
| 06 | 40086B002 | WASHER FLAT PL .125X.313 |
| 07 | 90932A001 | CABLE ASSEMBLY SPEAKER |
| 10 | 46021B005 | LABEL 506N3 BEZEL AT TEMP ID |
| 11 | 46426B006 | LABEL HARDWARE REVISION 6 |

 NIBP Only 92505A003 BEZEL ASSEMBLY NIBP ONLY

| Item # | CSI Part # | Description |
|--------|------------|-------------------------------|
| 01 | 42623B001 | FOAM PAD .50 X .75 |
| 02 | 45168B001 | BEZEL 506N3 |
| 03 | 45163B003 | MEMBRANE SW 506N3 NIBP ONLY |
| 04 | 90232A001 | AY MAIN AND DISPLAY BD 506N3 |
| 05 | 40995B005 | P.H.M.S. 4-40X.25 SEMS |
| 06 | 40086B002 | WASHER FLAT PL .125X.313 |
| 07 | 90932A001 | CABLE ASSEMBLY SPEAKER |
| 10 | 46021B012 | LABEL BEZEL NON-TEMP, NO SPO2 |
| 11 | 46426B002 | LABEL HARDWARE REVISION 2 |

NIBP/TEMP 92505A004 BEZEL ASSEMBLY NIBP/TEMP

| Item # | CSI Part # | Description |
|--------|------------|------------------------------|
| 01 | 42623B001 | FOAM PAD .50 X .75 |
| 02 | 45168B001 | BEZEL 506N3 |
| 03 | 45163B004 | MEMBRANE SW 506N3 W/O SPO2 |
| 04 | 90232A001 | AY MAIN AND DISPLAY BD 506N3 |
| 05 | 40995B005 | P.H.M.S. 4-40X.25 SEMS |
| 06 | 40086B002 | WASHER FLAT PL .125X.313 |
| 07 | 90932A001 | CABLE ASSEMBLY SPEAKER |
| 10 | 46021B013 | LABEL BEZEL TEMP, NO SPO2 |
| 11 | 46426B002 | LABEL HARDWARE REVISION 2 |

Rear Housing Assembly

93249A001 ASSEMBLY HOUSING REAR 506N3

| Item # | CSI Part # | Description |
|--------|------------|------------------------------------|
| 01 | 45167B001 | HOUSING 506N3 |
| 02 | 87277B001 | FOOT .50 OD X .19 H |
| 03 | 42651B002 | P.H.M.S. #4-40 SS .312 LONG |
| 04 | 40284B001 | NUT 4-40 KEPS PL |
| 05 | 82013B001 | FUSE TIME LG 500MA L 250V 5X20 |
| 06 | 83476B001 | AC POWER INLET |
| 07 | 42064B003 | F.H.M.S. 4-40X.312 PH PL |
| 08 | 90968A003 | CBL ASSEMBLY AC INLET/GROUND |
| 09 | 40067B002 | CABLE TIE 5.6 |
| 10 | 40294B001 | HOLDER TIE WRAP ADH-BK SM |
| 11 | 90928A001 | CABLE PRINTER RIBBON 26 POS |
| 12 | 42615B001 | FOAM PAD, PRINTER CABLE |
| 15 | 42614B001 | GASKET SIDE PANEL |
| 16 | 42601B001 | FOAM PAD .35 X 2.0 X .25 THICK |
| 17 | 90929A001 | CABLE ASSY BATTERY TO MAIN BRD |
| 18 | 45166B001 | BATTERY DOOR 506N3 |
| 19 | 83378B001 | SHCOK PAD .75DIA X .188TH |
| 21 | 42515B001 | LOCTITE #222MS THREADLCKR |
| 22 | 46021B002 | LABEL 506N3 REAR HOUSING AY ID |
| 23 | 46426B004 | LABEL HARDWARE REVISION 4 |
| 24 | 40193B003 | P.H.M.S. #4-40 X .375" COATED GREY |
| 25 | 42434B002 | P.H.M.S. 4-40X.375 316SS |

Chassis Assembly

95746A001 AY CHASSIS 506N3

| Item # | CSI Part # | Description |
|--------|------------|--------------------------------|
| 01 | 45164B001 | FRAME 506 GEMINI |
| 02 | 42595B001 | INSULATOR PWR SUPPLY |
| 03 | 42473B002 | STANDOFF F-F 6-32 X 1.500 |
| 05 | 93947A003 | AY 506N3 NIBP MODULE |
| 06 | 90926A002 | CABLE AY NIBP TO MAIN BOARD |
| 07 | 40995B006 | #4-40 P.H.M.S. SEMS PHILLIPS |
| 08 | 42499B001 | WASHER CUP NYLON #6 |
| 09 | 86517C001 | POWER SUPPLY MODIFIED |
| 10 | 90927A002 | CABLE POWER SUPPLY TO MAIN BRD |
| 11 | 40496B001 | P.H.M.S. 6-32X.375 SEMS |
| 12 | 46021B001 | LABEL 506N3 CHASSIS AY ID |
| 13 | 46426B003 | LABEL HARDWARE REVISION 3 |

NIBP**Module 93947A003 AY 506N3 NIBP MODULE**

| Item # | CSI Part # | Description |
|---------------|-------------------|---------------------------------|
| 01 | 40995B005 | P.H.M.S. 4-40X.25 SEMS |
| 02 | 41972B002 | INSULATOR OEM NIBP MODULE |
| 03 | 91325A002 | AY PCB NIBP 506N3 |
| 04 | 95597A002 | ASSEMBLY 506N3 NIBP PNEU (OKEN) |
| 05 | 46021B007 | LABEL 506N3 NIBP MODULE |
| 06 | 46426B004 | LABEL HARDWARE REVISION 4 |
| 08 | 95769A001 | ASSEMBLY OEM/506N3 NIBP MODULE |
| 09 | 41700B001 | TUBING POLYU .094IDX.187O |
| 10 | 41585B003 | TUBE CONNECTOR, 3/32 X 1/8 |
| 11 | 42014B002 | NIBP FITTING |
| 12 | 41700B002 | TUBE POLYU .125X.250 85DU |

Pneumatic 95597A002 ASSEMBLY 506N3 NIBP PNEU (OKEN)

| Item # | CSI Part # | Description |
|---------------|-------------------|----------------------------|
| 01 | 40067B002 | CABLE TIE 5.6 |
| 02 | 40296B002 | TUBING SILC BLU .125X.250 |
| 03 | 41700B001 | TUBING POLYU .094IDX.187O |
| 04 | 41579B003 | CHECK VALVE |
| 05 | 42069B001 | TUBING 1/4X1/8 POLYU COIL |
| 06 | 42081B002 | ORIFICE RESTRICTOR .0125 |
| 07 | 42104B001 | BRACKET OEM NIBP OS VALVE |
| 08 | 42111B001 | SCREW M2-.4X3 PH BINDER |
| 09 | 84500B001 | PUMP PRIMARY BP ENCL |
| 10 | 95576A001 | CABLE 506DX PUMP AY |
| 11 | 95595A001 | AY VP NIBP MANIFOLD |
| 12 | 95596A001 | AY OKEN VALVE W/ CONNECTOR |
| 13 | 40132B001 | TAPE MICROFOAM ADH-BACKED |
| 14 | 40296B001 | TUBING SILC BLU .040X.140 |
| 15 | 41585B003 | TUBE CONNECTOR 3/32 X 1/8 |
| 16 | 41700B002 | TUBE POLYU .125X.250 85DU |
| 17 | 42014B002 | NIBP FITTING |

PCB Assembly

90232A001 AY PCB 506N3

| Item # | CSI Part # | Description |
|---------------|-------------------|--------------------------------|
| 01 | 42255B003 | STANDOFF M-F 2-56 X .188 |
| 02 | 91384A003 | ASSEMBLY PCB MAIN BOARD 506 N3 |
| 03 | 40008B005 | NUT HEX 2-56 PL |
| 04 | 90029A001 | LCD ASSEMBLY WITH HEADER |
| 05 | 41258B003 | P.H.M.S. #2-56X.188 LGSEMS |
| 06 | 87282B001 | HEADER, STACKING 12 POS, .050" |
| 07 | 91388A001 | PCB AY DISPLAY BOARD 506 PH3 |
| 08 | 40995B005 | P.H.M.S. 4-40X.25 SEMS |
| 09 | 42613B001 | GASKET SERIAL PORT |
| 10 | 45169B001 | CONN, SERIAL COLLAR 506N3 |
| 11 | 40995B006 | #4-40 P.H.M.S. SEMS PHILLIPS |
| 12 | 40284B001 | NUT 4-40 KEPS PL |
| 13 | 46021B003 | LABEL 506N3 MAIN/DIS PCB AY ID |
| 14 | 46426B004 | LABEL HARDWARE REVISION 4 |
| 15 | 42515B001 | LOCTITE #222MS THREADLCKR |

Printer Assembly

95745A001 PRINTER ASSEMBLY 506N3

| Item # | CSI Part # | Description |
|---------------|-------------------|------------------------------|
| 01 | 84005B002 | PRINTER SEIKO W/O KNOB |
| 02 | 91389A002 | PCB ASSY PRINTER BOARD 506N3 |
| 03 | 45173B001 | PRNTR HOUSING 506N3 |
| 04 | 45174B001 | PRNTR DOOR 506 GEMINI |
| 05 | 45175B001 | PAPER FEED MEMBRANE 506 |
| 06 | 42603B001 | INSULATOR CHASSIS TOP 506 |
| 07 | 42620B001 | DRIP GUARD PRINTER BRD |
| 08 | 40995B005 | P.H.M.S. 4-40X.25 SEMS |
| 09 | 46021B006 | LABEL 506N3 PRINTER AY ID |
| 10 | 46426B002 | LABEL HARDWARE REVISION 2 |

Appendix A —Main Board Upgrades

Overview

The VitalCare™ 506N3 Series Patient Monitor may have one of three available Main Boards:

- 91384A001
- 91384A002
- 91384A003

Most monitors built prior to 2007 will have Main Board (pn 91384A002), although some older monitors may be equipped with Main Board (pn 91384A001). Monitors built in 2007 and beyond will be assembled using Main Board (pn 91384A003) or later version.

Main Board (pn 91384A003) provides the monitor with a Battery Disconnect Warning indicator when used with 1.5A software or higher.

CAUTION



- Do not open the case. Sensitive electronic components may be damaged by electrostatic discharge. Opening the case requires an electrostatic discharge (ESD) protected work bench.

Battery Disconnect Warning Indicator

The Battery Disconnect Warning indicator is intended to indicate that the battery is either disconnected inside the monitor or the battery internal circuit is open.

The Battery Disconnect Warning indicator will cause the “Battery Indicator” light to flash red and green if the battery is not connected while the monitor is connected to an AC power source. This feature is intended to alert the user that the battery is not connected properly and that the monitor should be serviced.

Backward Compatibility

The Main Board is backward compatible, meaning that older machines using Main Board (91384A001 or A002) may be repaired using Main Board (91384A003). Main Board (91384A003) will function properly in older machines but the Battery Disconnect Warning indicator function will not be available unless the monitor is also updated with the newest software.

NOTE: Check software revision after installing replacement Main Boards to ensure that the replacement board has the most current software installed.

NOTE: The technology modules, such as the NIBP module, have their own software and will not be updated with a Main Board replacement.

Upgrading the Main Board

This procedure details the replacement of a pn 91384A001 or 91384A002 Main Board with a pn 91384A003 Main Board.

Removing the old Main Board

First perform “Disassemble Front Bezel from Rear Housing” procedure in Section 7.

1. Disconnect the green ground wire from the metal chassis. The ground wire to the chassis is not necessary with new Main Boards (pn 93184A003 or newer).
2. Remove the speaker from the rail of the bezel. Lift the orange and brown wires from the relief of main as shown below.

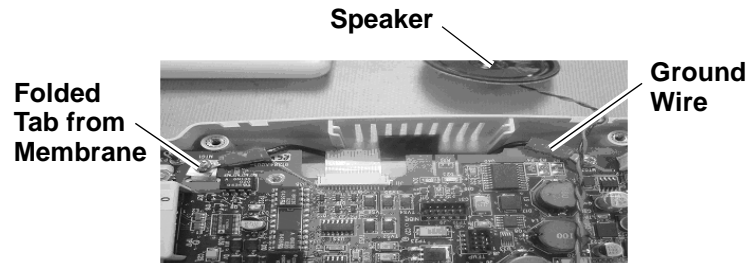

Figure A-1: Remove Speaker

3. Unplug the speaker assembly (pn 90939A001) from **J3** of the Main Board. Place speaker assembly aside.
4. With a #1 Phillips screwdriver, remove the two (2) screws (pn 40995B005) holding the ground wire to the Main Board. Set the ground wire and screws aside. Note the side with the folded ground tail.
5. Remove the three (3) remaining screws located on the top, left and middle.
6. Unlock the membrane tail at **J11** and remove the tail from the connector.
7. Remove the assembly from the bezel.
8. Flip the PCB over. Using a #0 Phillips screwdriver, remove all four (4) screws (pn 41258B003) from the LCD display. Lift and remove.

9. Using a #1 Phillips screwdriver, remove the six (6) screws (pn 40995B005) from the display board (pn 91388A001). Lift and remove. There will be a display board header beneath the display board.
10. Using a 1/4 nut driver, remove the slide collar that is over the DB-9 connector. A #1 Phillips screwdriver may be needed to hold the screw on the other side.
11. Using a 3/16 nut driver, remove the standoffs and nuts that are attached to the Main Board.
12. Replace the Main Board with the new one (pn 91384A003).

Installing the new Main Board

1. Mount four (4) standoffs M/F (pn 42255B003) onto the Main Board (PCB side without connectors) using four (4) nuts (pn 40008B005).
2. Install LCD Display Assembly (pn 90029A001) to the Main Board Assembly using four (4) #2 screws (pn 41258B003). Torque at 2 in. lbs.
3. Plug display board header (pn 87282B001) into the Main Board at **J1** or **J7**.
4. Carefully place and align the LED display board assembly (pn 91388A001) onto the Main Board using the standoffs as a guide and make sure header is connected into display board.
5. Mount the LED display board using six (6) P.H.M.S. screws (pn 40995B005). Torque 5 in. lbs.
6. Slide collar over the DB-9 connector and mount this to the Main Board using two (2) P.H.M.S. screws (pn 40995B006) and securing with two (2) nuts (pn 40284B001).

NOTE: Nuts will lie on top of collar plastic. Torque at 5 in. lbs.

7. Air out the bezel with an air ionizer before mounting PCB. Place the ground tail from the membrane through the opening of the Main Board assembly.
8. Tilt the PCB assembly so that it is on an angle. Lift the bezel up so that the tail of the membrane slides through the opening of the PCB assembly. Place the two together and lay back down on the table.
9. Mount the PCB assembly to the bezel using four (4) P.H.M.S. screws (pn 40995B005). (These are upper screws. DO NOT tighten down.)
10. Unlock connector from membrane and attach the membrane tail into it. Close the connector by pushing it close. Keep the membrane straight and even.

11. Fold over the membrane's ground tail and connect to the Main Board using a P.H.M.S. screw (pn 40995B005) and washer (pn 40086B002). Attach the right side of the bezel and torque all five (5) screws at 5 in. lbs.

If a washer is unavailable, the black ground wire that was removed earlier can be reused by inserting P.H.M.S. screws through the ring terminal (lower right corner) and both holes of the ground tail. Route the black ground wire under the membrane tail.

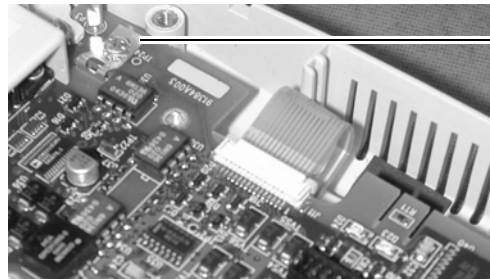

**Membrane
Ground Tail**

Figure A-2: Membrane Ground Tail

12. Plug speaker assembly (pn 90932A001) into **J3** of the Main Board.
13. Slide the speaker into the front rail of the bezel. Place the orange and brown wires into relief as shown below.

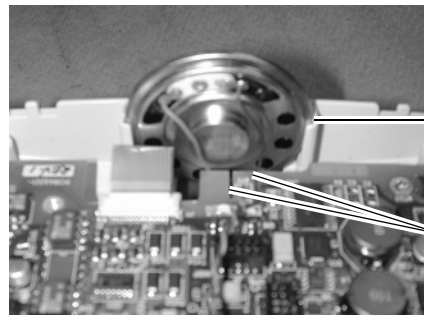

Front Rail

Relief Strain

Figure A-3: Reinsert Speaker

Reassemble monitor and follow “Completion of Service” procedure at the end of Section 7.

| REVISIONS | | | |
|-----------|----------|---------------|-----|
| REV. | DATE | DESCRIPTION | BY |
| 1 | 08-31-05 | SEE ECN #8496 | SC |
| 2 | 11/18/05 | SEE ECN #8590 | DBL |
| 3 | 01/24/06 | SEE ECN #8652 | TLR |
| 4 | 06/28/06 | SEE ECN #8670 | SC |
| 5 | 12/7/06 | SEE ECN #8922 | DBL |

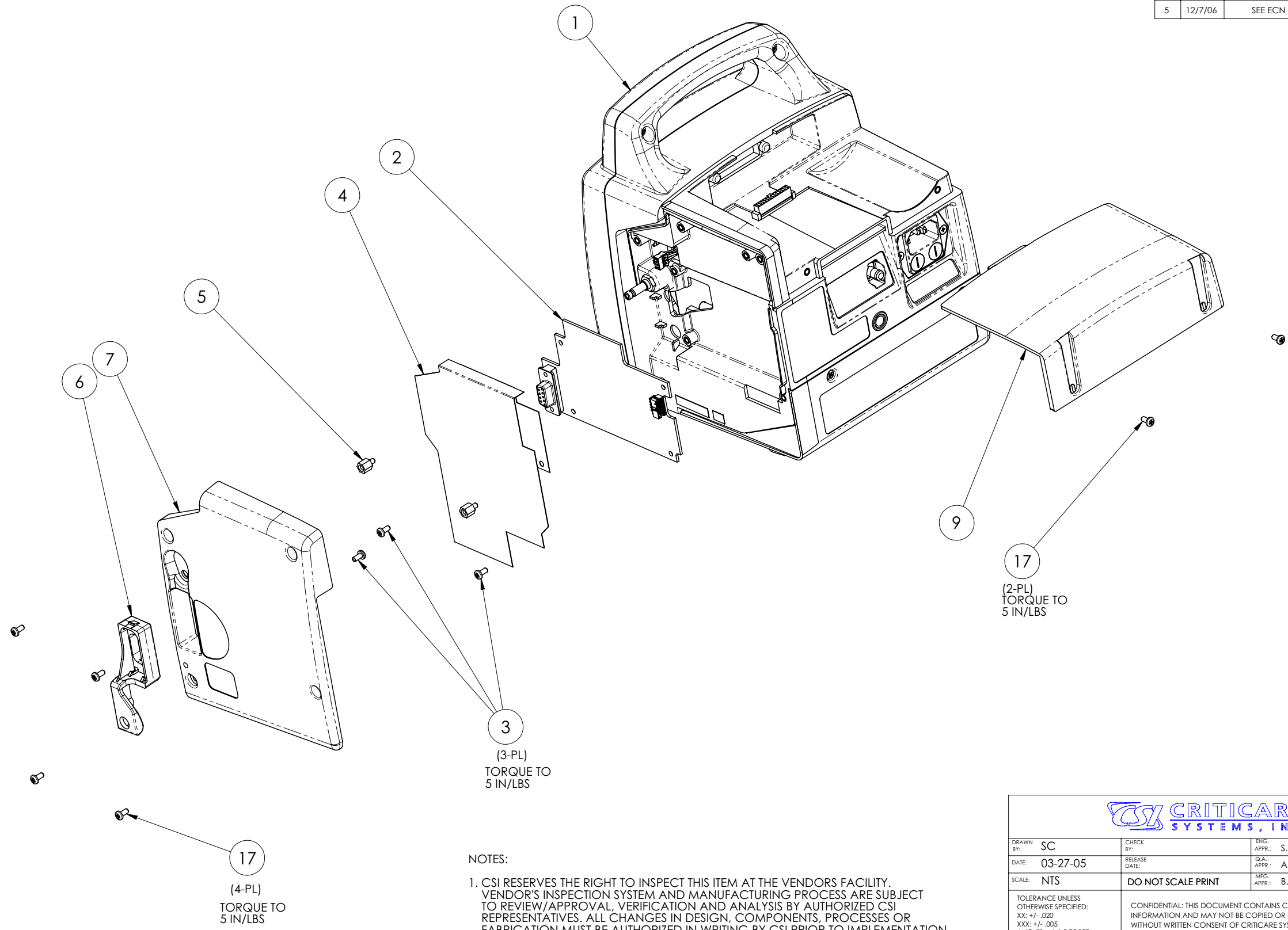

NOTES:

1. CSI RESERVES THE RIGHT TO INSPECT THIS ITEM AT THE VENDORS FACILITY. VENDOR'S INSPECTION SYSTEM AND MANUFACTURING PROCESS ARE SUBJECT TO REVIEW/APPROVAL, VERIFICATION AND ANALYSIS BY AUTHORIZED CSI REPRESENTATIVES. ALL CHANGES IN DESIGN, COMPONENTS, PROCESSES OR FABRICATION MUST BE AUTHORIZED IN WRITING BY CSI PRIOR TO IMPLEMENTATION. ALL DEVIATIONS FROM DRAWINGS, SPECIFICATIONS, OR OTHER REQUIREMENTS MUST BE REPORTED TO CSI FOR APPROVAL PRIOR TO SHIPMENT.

SW

| | | |
|--|--------------------|--|
| | | |
| DRAWN BY: SC | CHECK BY: | ENG. APPR.: S. COOGAN 7/21/05 |
| DATE: 03-27-05 | RELEASE DATE: | Q.A. APPR.: A. KAPLAN 7/21/05 |
| SCALE: NTS | DO NOT SCALE PRINT | MFG. APPR.: B. LEWANDOWSKI 7/25/05 |
| TOLERANCE UNLESS OTHERWISE SPECIFIED: XX: +/- .020 XXX: +/- .005 ANGLES: +/- 1 DEGREE | | CONFIDENTIAL: THIS DOCUMENT CONTAINS CONFIDENTIAL INFORMATION AND MAY NOT BE COPIED OR DIVULGED WITHOUT WRITTEN CONSENT OF CRITICARE SYSTEMS, INC. |
| TITLE: FINAL ASSEMBLY 506DN3 CSI DOX SPO2 | | PART NO.: 93975A001 |
| | | REV. 5 |
| DIST: - | | SHEET 1 OF 2 |

| REVISIONS | | | |
|-----------|------|-------------|----|
| REV. | DATE | DESCRIPTION | BY |
| | | | |

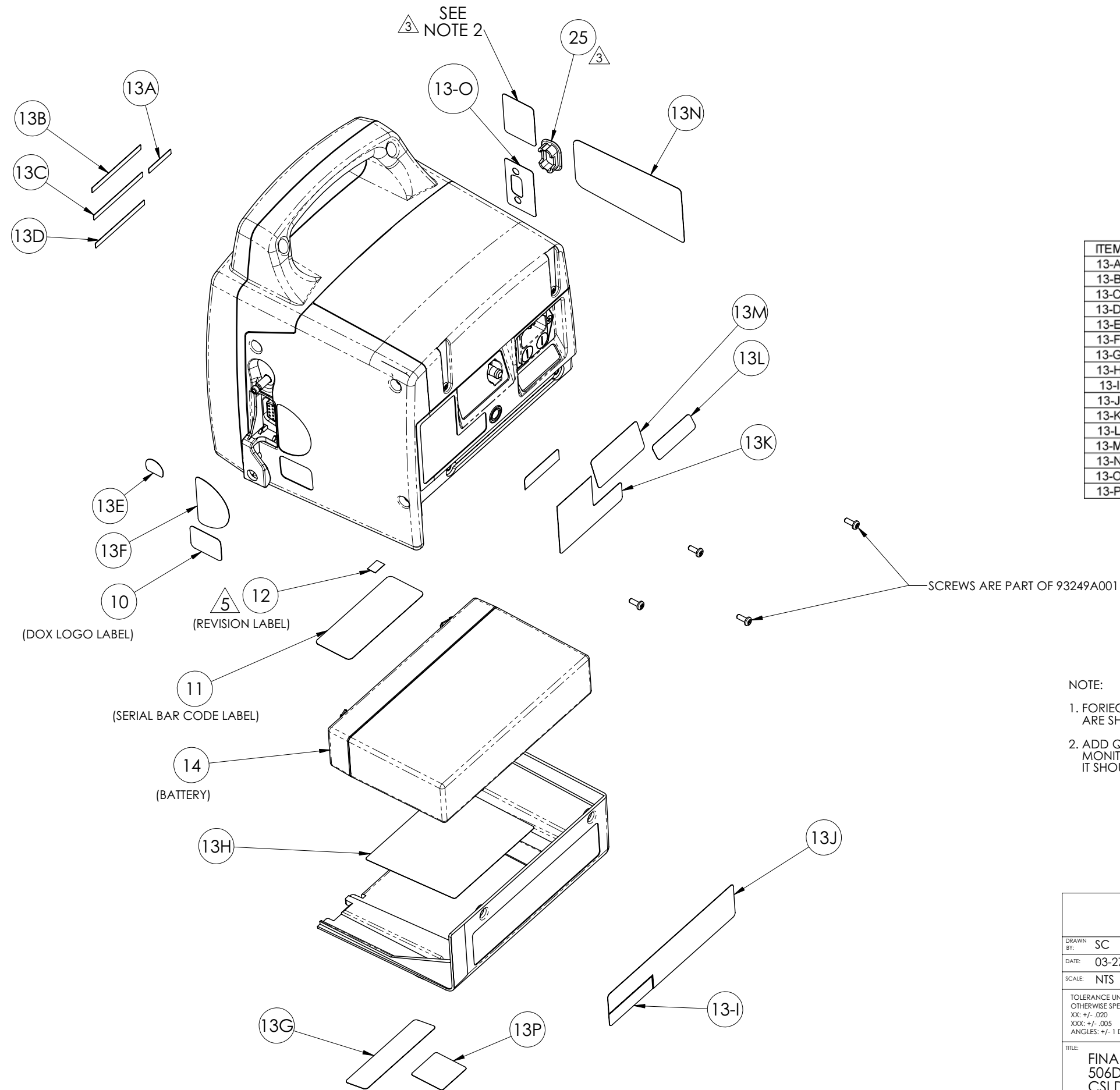

LABELS FROM SET (ITEM 13)

| ITEM | DESCRIPTION |
|------|----------------------------------|
| 13-A | LABEL, LANGUAGE, MENU |
| 13-B | LABEL, LANGUAGE, TREND/PRINT |
| 13-C | LABEL, LANGUAGE, NIBP CYCLE |
| 13-D | LABEL, LANGUAGE, NIBP START/STAT |
| 13-E | LABEL, NIBP FITTING (NON-TEMP) |
| 13-F | LABEL, SPO2 CONN. (NON-TEMP) |
| 13-G | LABEL, CSI PATENT |
| 13-H | LABEL, BATTERY INSTALL |
| 13-I | LABEL, COUNTRY OF ORIGIN |
| 13-J | LABEL, CSI SUPPORT INFO |
| 13-K | LABEL, ETL SYMBOL |
| 13-L | LABEL, FUSE RATING |
| 13-M | LABEL, ELECTRICAL RATING |
| 13-N | LABEL, WARNINGS |
| 13-O | LABEL, SERIAL PORT |
| 13-P | LABEL, WEEE DIRECTIVE |

NOTE:

1. FOREIGN LANGUAGE LABELS INSTALLED AT THE CAT LEVEL. THEY ARE SHOWN ON THIS DRAWING FOR REFERENCE ONLY.
2. ADD QUALITY SEAL PN; 46036B101 (FROM CAT LEVEL BOM) TO MONITOR APPROXIMATELY ONE INCH ABOVE THE SERIAL PORT. IT SHOULD COVER THE FRONT AND REAR HOUSINGS.

SW



| | | |
|--|---------------------|--|
| DRAWN BY: SC | CHECK BY: | ENG. APPR.: |
| DATE: 03-27-05 | RELEASE DATE: | Q.A. APPR.: |
| SCALE: NTS | DO NOT SCALE PRINT | MFG. APPR.: |
| TOLERANCE UNLESS OTHERWISE SPECIFIED: XX: +/- .020 XXX: +/- .005 ANGLES: +/- 1 DEGREE | | CONFIDENTIAL: THIS DOCUMENT CONTAINS CONFIDENTIAL INFORMATION AND MAY NOT BE COPIED OR DIVULGED WITHOUT WRITTEN CONSENT OF CRITICARE SYSTEMS, INC. |
| TITLE: FINAL ASSEMBLY 506DN3 CSI DOX SPO2 | PART NO.: 93975A001 | REV. 5 |
| DST: 302 | | SHEET 2 OF 2 |

| REVISIONS | | | |
|-----------|----------|---------------|-----|
| REV. | DATE | DESCRIPTION | BY |
| 1 | 09-01-05 | SEE ECN #8496 | SC |
| 2 | 11/18/05 | SEE ECN #8590 | DBL |
| 3 | 01/25/06 | SEE ECN #8652 | TLR |
| 4 | 06/28/06 | SEE ECN #8670 | SC |
| 5 | 12/7/06 | SEE ECN #8922 | DBL |

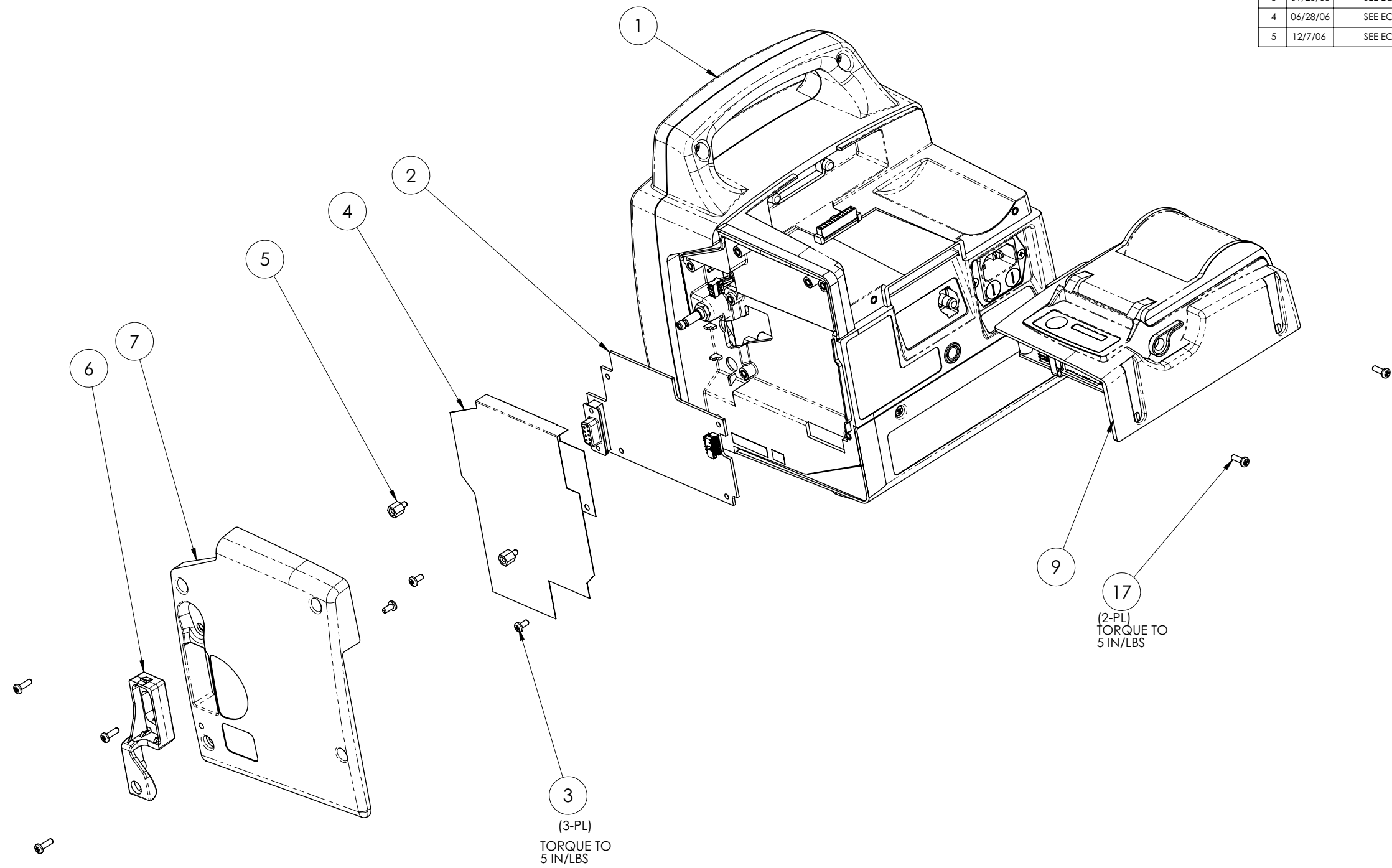

NOTES:

1. CSI RESERVES THE RIGHT TO INSPECT THIS ITEM AT THE VENDORS FACILITY. VENDOR'S INSPECTION SYSTEM AND MANUFACTURING PROCESS ARE SUBJECT TO REVIEW/APPROVAL, VERIFICATION AND ANALYSIS BY AUTHORIZED CSI REPRESENTATIVES. ALL CHANGES IN DESIGN, COMPONENTS, PROCESSES OR FABRICATION MUST BE AUTHORIZED IN WRITING BY CSI PRIOR TO IMPLEMENTATION. ALL DEVIATIONS FROM DRAWINGS, SPECIFICATIONS, OR OTHER REQUIREMENTS MUST BE REPORTED TO CSI FOR APPROVAL PRIOR TO SHIPMENT.

17
(4-PL)
TORQUE TO
5 IN/LBS

| | | |
|--|--------------------|--|
| | | |
| DRAWN BY: SC | CHECK BY: | ENG. APPR.: S. COOGAN 7/21/05 |
| DATE: 03-27-05 | RELEASE DATE: | Q.A. APPR.: A. KAPLAN 7/21/05 |
| SCALE: NTS | DO NOT SCALE PRINT | MFG. APPR.: B. LEWANDOWSKI 7/25/05 |
| TOLERANCE UNLESS OTHERWISE SPECIFIED: XX: +/- .020 XXX: +/- .005 ANGLES: +/- 1 DEGREE | | CONFIDENTIAL: THIS DOCUMENT CONTAINS CONFIDENTIAL INFORMATION AND MAY NOT BE COPIED OR DIVULGED WITHOUT WRITTEN CONSENT OF CRITICARE SYSTEMS, INC. |
| TITLE: FINAL ASSEMBLY 506DNP3 CSI DOX SPO2, PRINTER | | PART NO.: 93975A002 |
| DIST: 302 | | REV. 5 |
| SHEET 1 OF 2 | | |

| REVISIONS | | | |
|-----------|------|-------------|----|
| REV. | DATE | DESCRIPTION | BY |
| | | | |

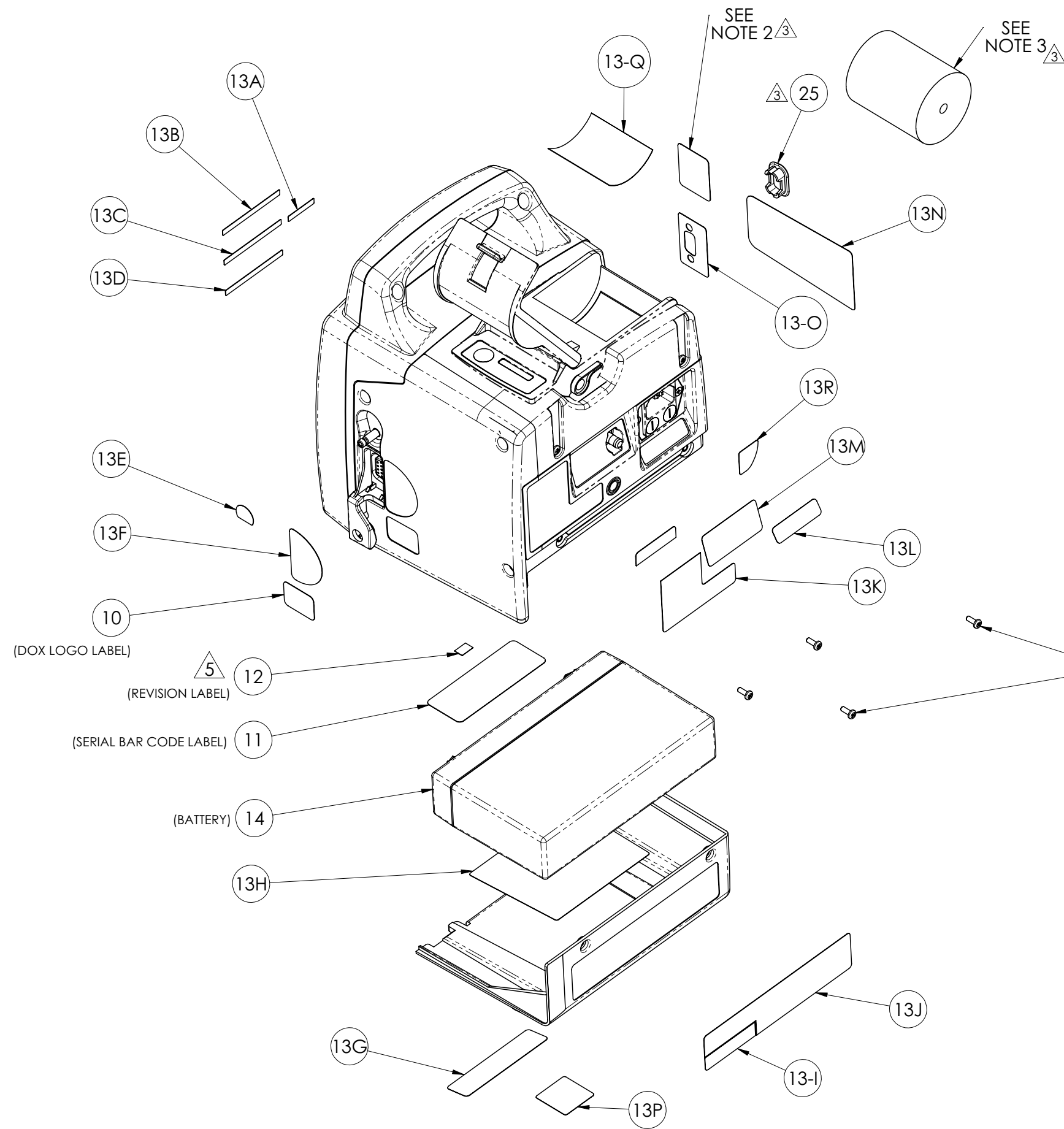

LABELS FROM SET (ITEM 13)

| ITEM | DESCRIPTION |
|------|----------------------------------|
| 13-A | LABEL, LANGUAGE, MENU |
| 13-B | LABEL, LANGUAGE, TREND/PRINT |
| 13-C | LABEL, LANGUAGE, NIBP CYCLE |
| 13-D | LABEL, LANGUAGE, NIBP START/STAT |
| 13-E | LABEL, NIBP FITTING (NON-TEMP) |
| 13-F | LABEL, SPO2 CONN. (NON-TEMP) |
| 13-G | LABEL, CSI PATENT |
| 13-H | LABEL, BATTERY INSTALL |
| 13-I | LABEL, COUNTRY OF ORIGIN |
| 13-J | LABEL, CSI SUPPORT INFO |
| 13-K | LABEL, ETL SYMBOL |
| 13-L | LABEL, FUSE RATING |
| 13-M | LABEL, ELECTRICAL RATING |
| 13-N | LABEL, WARNINGS |
| 13-O | LABEL, SERIAL PORT |
| 13-P | LABEL, WEEE DIRECTIVE |
| 13-Q | LABEL, PAPER LOADING |
| 13-R | LABEL, PAPER RELEASE |

NOTE:

1. FOREIGN LANGUAGE LABELS INSTALLED AT THE CAT LEVEL. THEY ARE SHOWN ON THIS DRAWING FOR REFERENCE ONLY.
2. ADD QUALITY SEAL PN: 46036B101 (FROM CAT LEVEL BOM) TO MONITOR APPROXIMATELY ONE INCH ABOVE THE SERIAL PORT. IT SHOULD COVER THE FRONT AND REAR HOUSINGS.
3. INSTALL PRINTER PAPER PN: 40065B002 (CAT LEVEL) INTO PRINTER HOUSING.

SW



| | | |
|--|--------------------|--|
| DRAWN BY: SC | CHECK BY: | ENG. APPR.: |
| DATE: 03-27-05 | RELEASE DATE: | Q.A. APPR.: |
| SCALE: NTS | DO NOT SCALE PRINT | MFG. APPR.: |
| TOLERANCE UNLESS OTHERWISE SPECIFIED: XX: +/- .020 XXX: +/- .005 ANGLES: +/- 1 DEGREE | | CONFIDENTIAL: THIS DOCUMENT CONTAINS CONFIDENTIAL INFORMATION AND MAY NOT BE COPIED OR DIVULGED WITHOUT WRITTEN CONSENT OF CRITICARE SYSTEMS, INC. |
| TITLE: FINAL ASSEMBLY 506DNP3 CSI DOX SPO2, PRINTER | | PART NO.: 93975A002 |
| DIST: 302 | | REV. 5 |
| SHEET 2 OF 2 | | |

NOTES:

1. CSI RESERVES THE RIGHT TO INSPECT THIS ITEM AT THE VENDORS FACILITY. VENDOR'S INSPECTION SYSTEM AND MANUFACTURING PROCESS ARE SUBJECT TO REVIEW/APPROVAL, VERIFICATION AND ANALYSIS BY AUTHORIZED CSI REPRESENTATIVES. ALL CHANGES IN DESIGN, COMPONENTS, PROCESSES OR FABRICATION MUST BE AUTHORIZED IN WRITING BY CSI PRIOR TO IMPLEMENTATION. ALL DEVIATIONS FROM DRAWINGS, SPECIFICATIONS, OR OTHER REQUIREMENTS MUST BE REPORTED TO CSI FOR APPROVAL PRIOR TO SHIPMENT.

| REVISIONS | | | |
|-----------|----------|---------------|-----|
| REV. | DATE | DESCRIPTION | BY |
| 1 | 09-01-05 | SEE ECN #8496 | SC |
| 2 | 11/18/05 | SEE ECN #8590 | DBL |
| 3 | 01/26/06 | SEE ECN #8652 | TLR |
| 4 | 06/28/06 | SEE ECN #8670 | SC |
| 5 | 12/7/06 | SEE ECN #8922 | DBL |

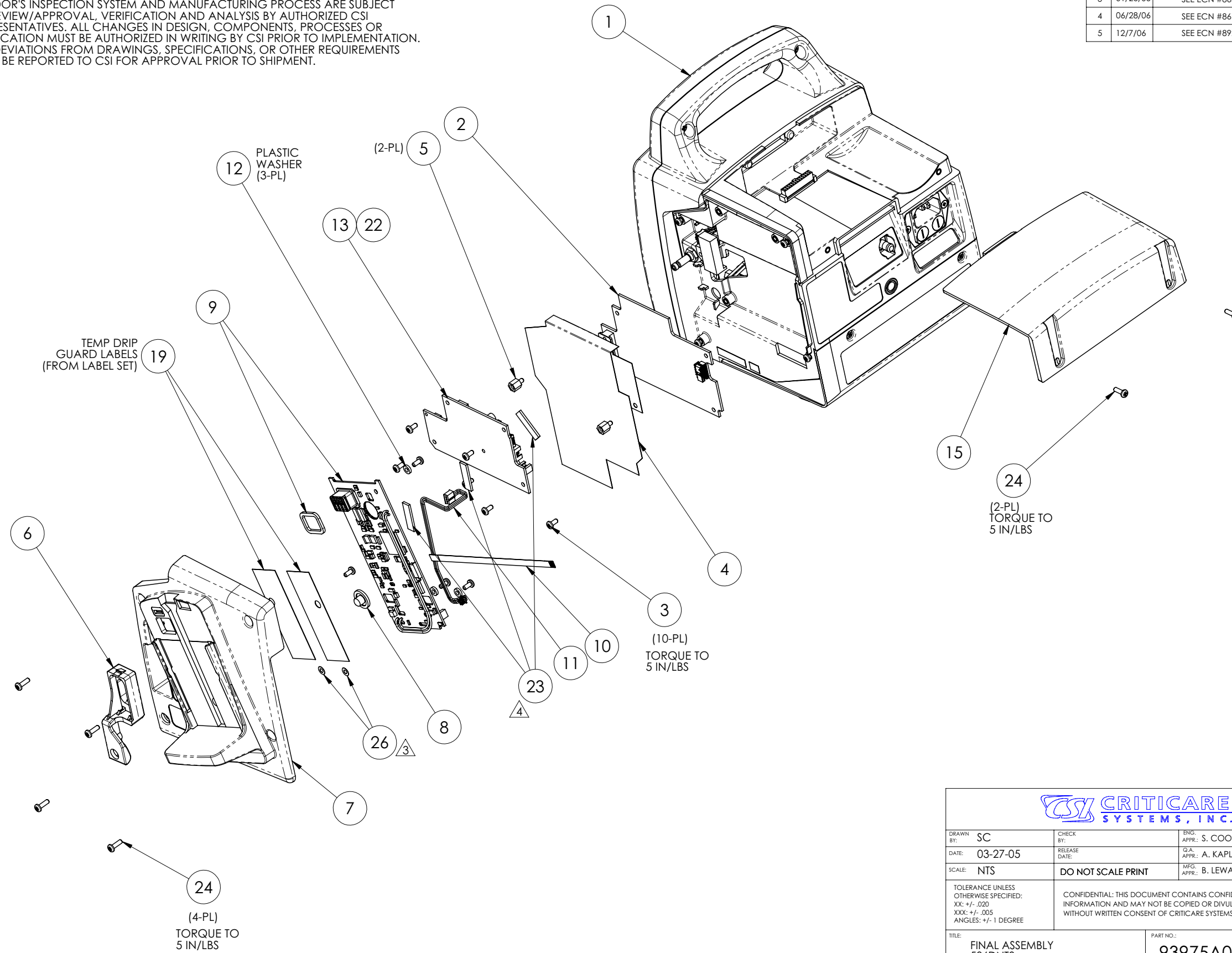

SW

| DRAWN BY: SC | CHECK BY: | ENG. APPR.: S. COOGAN 7/21/05 |
|--|--------------------|--|
| DATE: 03-27-05 | RELEASE DATE: | Q.A. APPR.: A. KAPLAN 7/21/05 |
| SCALE: NTS | DO NOT SCALE PRINT | MFG. APPR.: B. LEWANDOWSKI 7/25/05 |
| TOLERANCE UNLESS OTHERWISE SPECIFIED: XX: +/- .020 XXX: +/- .005 ANGLES: +/- 1 DEGREE | | CONFIDENTIAL: THIS DOCUMENT CONTAINS CONFIDENTIAL INFORMATION AND MAY NOT BE COPIED OR DIVULGED WITHOUT WRITTEN CONSENT OF CRITICARE SYSTEMS, INC. |
| TITLE: FINAL ASSEMBLY 506DNT3 CSI DOX SPO2, TEMPERATURE | | PART NO.: 93975A003 REV.: 5 |
| DIST: 302 | | SHEET 1 OF 2 |

| REVISIONS | | | |
|-----------|------|-------------|----|
| REV. | DATE | DESCRIPTION | BY |
| | | | |

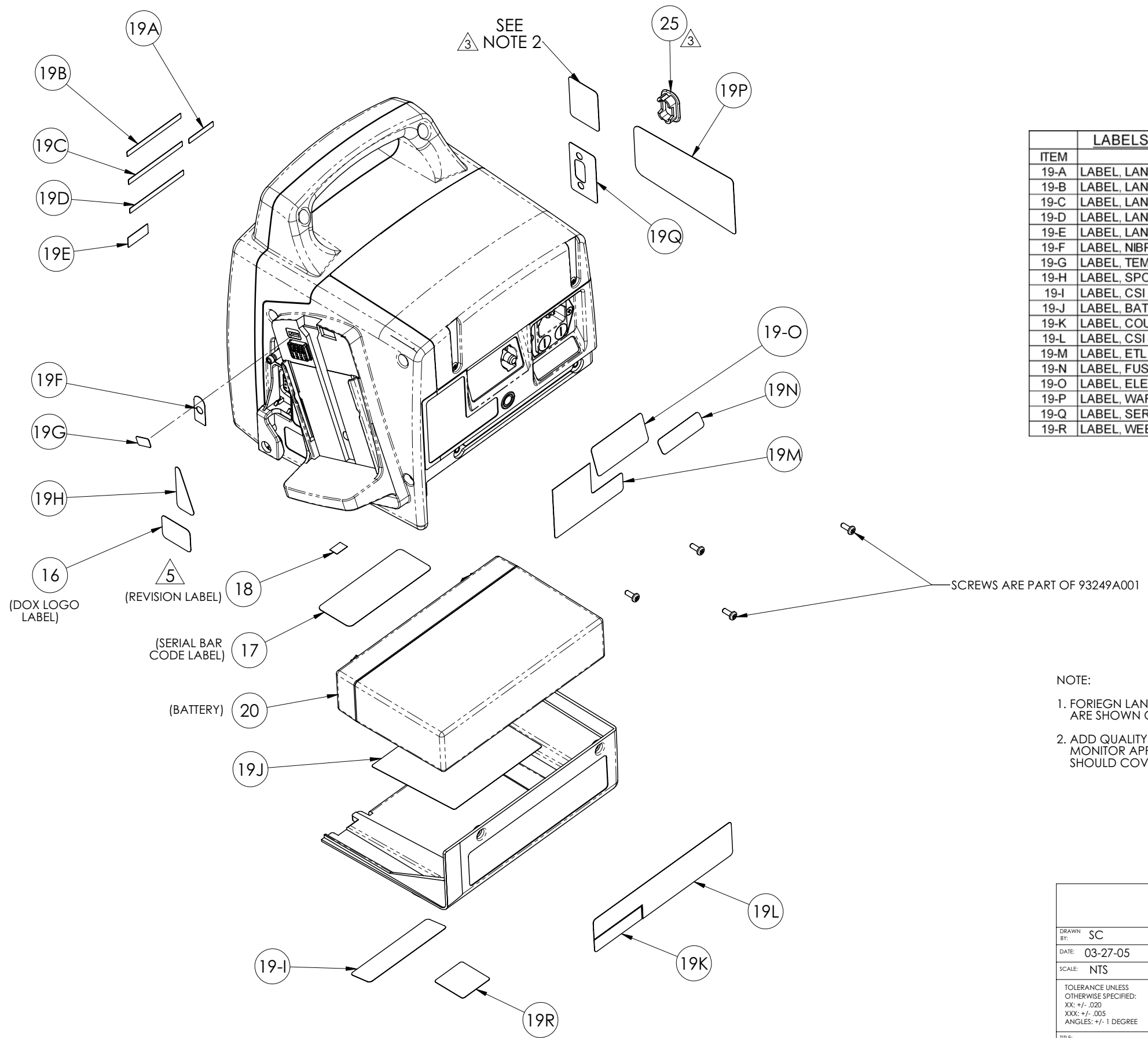

| LABELS FROM SET (ITEM 19) | |
|---------------------------|----------------------------------|
| ITEM | DESCRIPTION |
| 19-A | LABEL, LANGUAGE, MENU |
| 19-B | LABEL, LANGUAGE, TREND/PRINT |
| 19-C | LABEL, LANGUAGE, NIBP CYCLE |
| 19-D | LABEL, LANGUAGE, NIBP START/STAT |
| 19-E | LABEL, LANGUAGE, TEMP. ORAL/AX |
| 19-F | LABEL, NIBP FITTING |
| 19-G | LABEL, TEMP. COVER |
| 19-H | LABEL, SPO2 CONN. |
| 19-I | LABEL, CSI PATENT |
| 19-J | LABEL, BATTERY INSTALL |
| 19-K | LABEL, COUNTRY OF ORIGIN |
| 19-L | LABEL, CSI SUPPORT INFO |
| 19-M | LABEL, ETL SYMBOL |
| 19-N | LABEL, FUSE RATING |
| 19-O | LABEL, ELECTRICAL RATING |
| 19-P | LABEL, WARNINGS |
| 19-Q | LABEL, SERIAL PORT |
| 19-R | LABEL, WEEE DIRECTIVE |

NOTE:

1. FOREIGN LANGUAGE LABELS INSTALLED AT THE CAT LEVEL. THEY ARE SHOWN ON THIS DRAWING FOR REFERENCE ONLY.
2. ADD QUALITY SEAL PN: 46036B101 (FROM CAT LEVEL BOM) TO MONITOR APPROXIMATELY ONE INCH ABOVE THE SERIAL PORT. IT SHOULD COVER THE FRONT AND REAR HOUSINGS.

SW

| | | |
|--|------------------------|--|
| | | |
| DRAWN BY: SC | CHECK BY: | ENG. APPR.: |
| DATE: 03-27-05 | RELEASE DATE: | Q.A. APPR.: |
| SCALE: NTS | DO NOT SCALE PRINT | |
| TOLERANCE UNLESS OTHERWISE SPECIFIED: XX: +/- .020 XXX: +/- .005 ANGLES: +/- 1 DEGREE | | CONFIDENTIAL: THIS DOCUMENT CONTAINS CONFIDENTIAL INFORMATION AND MAY NOT BE COPIED OR DIVULGED WITHOUT WRITTEN CONSENT OF CRITICARE SYSTEMS, INC. |
| TITLE: FINAL ASSEMBLY 506DNT3 CSI DOX SPO2, TEMPERATURE | PART NO.: 93975A003 | REV.: 5 |
| DIST: 302 | | SHEET 2 OF 2 |

| REVISIONS | | | |
|-----------|----------|---------------|-----|
| REV. | DATE | DESCRIPTION | BY |
| 1 | 09-01-05 | SEE ECN #8496 | SC |
| 2 | 11/18/05 | SEE ECN #8590 | DBL |
| 3 | 01/31/06 | SEE ECN #8652 | TLR |
| 4 | 06/28/06 | SEE ECN #8670 | SC |
| 5 | 12/7/06 | SEE ECN #8922 | DBL |

NOTES:

1. CSI RESERVES THE RIGHT TO INSPECT THIS ITEM AT THE VENDORS FACILITY. VENDOR'S INSPECTION SYSTEM AND MANUFACTURING PROCESS ARE SUBJECT TO REVIEW/APPROVAL, VERIFICATION AND ANALYSIS BY AUTHORIZED CSI REPRESENTATIVES. ALL CHANGES IN DESIGN, COMPONENTS, PROCESSES OR FABRICATION MUST BE AUTHORIZED IN WRITING BY CSI PRIOR TO IMPLEMENTATION. ALL DEVIATIONS FROM DRAWINGS, SPECIFICATIONS, OR OTHER REQUIREMENTS MUST BE REPORTED TO CSI FOR APPROVAL PRIOR TO SHIPMENT.

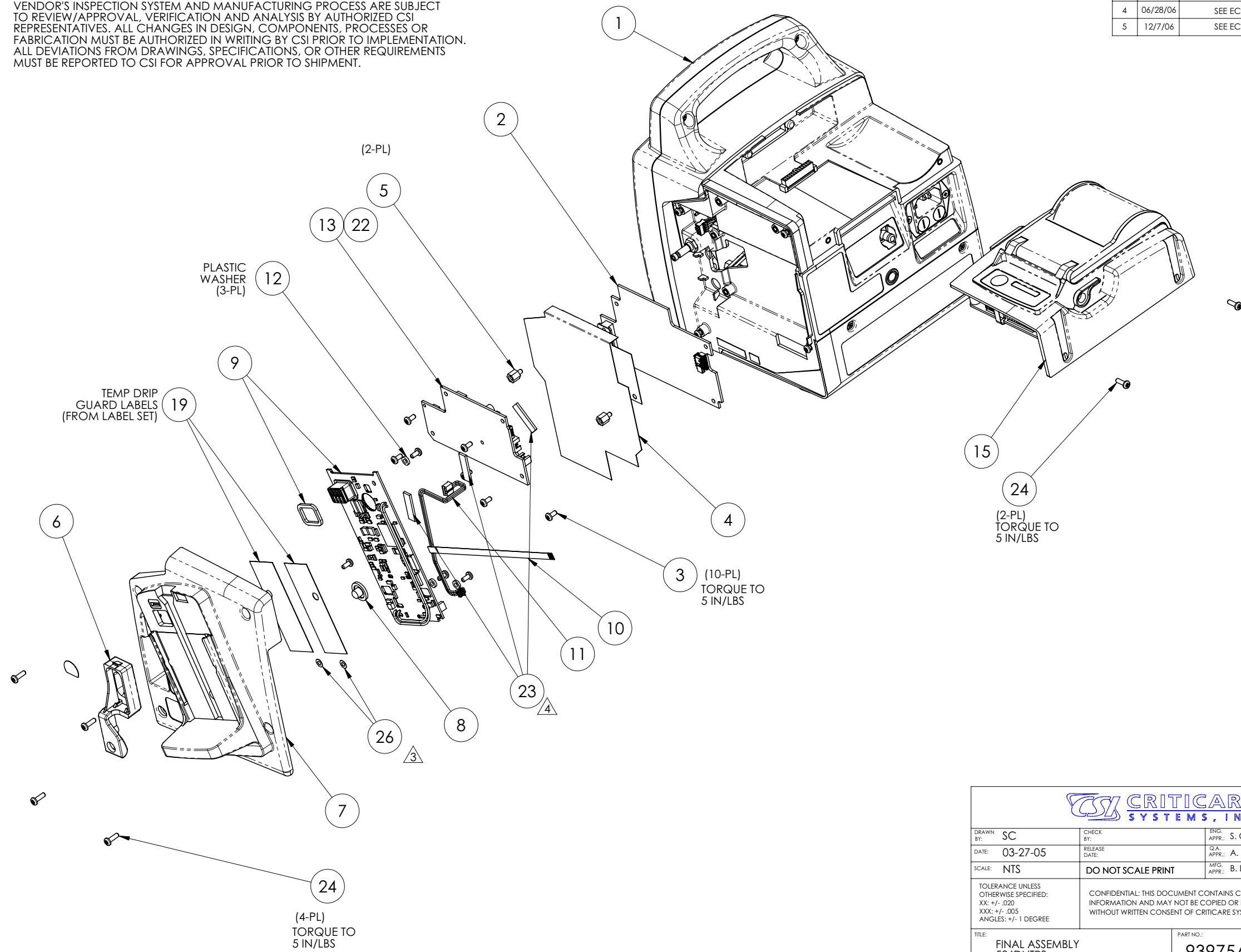

SW

| | | |
|--|--------------------|--|
| | | |
| DRAWN BY: SC | CHECK BY: | ENG. APPR.: S. COOGAN 7/21/05 |
| DATE: 03-27-05 | RELEASE DATE: | Q.A. APPR.: A. KAPLAN 7/21/05 |
| SCALE: NTS | DO NOT SCALE PRINT | MFG. APPR.: B. LEWANDOWSKI 7/25/05 |
| TOLERANCE UNLESS OTHERWISE SPECIFIED: XX: +/- .020 XXX: +/- .005 ANGLES: +/- 1 DEGREE | | CONFIDENTIAL: THIS DOCUMENT CONTAINS CONFIDENTIAL INFORMATION AND MAY NOT BE COPIED OR DIVULGED WITHOUT WRITTEN CONSENT OF CRITICARE SYSTEMS, INC. |
| TITLE: FINAL ASSEMBLY 506DNTP3 CSI DOX SPO2, TEMP, PRINTER | | PART NO.: 93975A004 |
| DIST: 302 | | REV. 5 |
| SHEET 1 OF 2 | | |

| REVISIONS | | | |
|-----------|------|-------------|----|
| REV. | DATE | DESCRIPTION | BY |
| | | | |

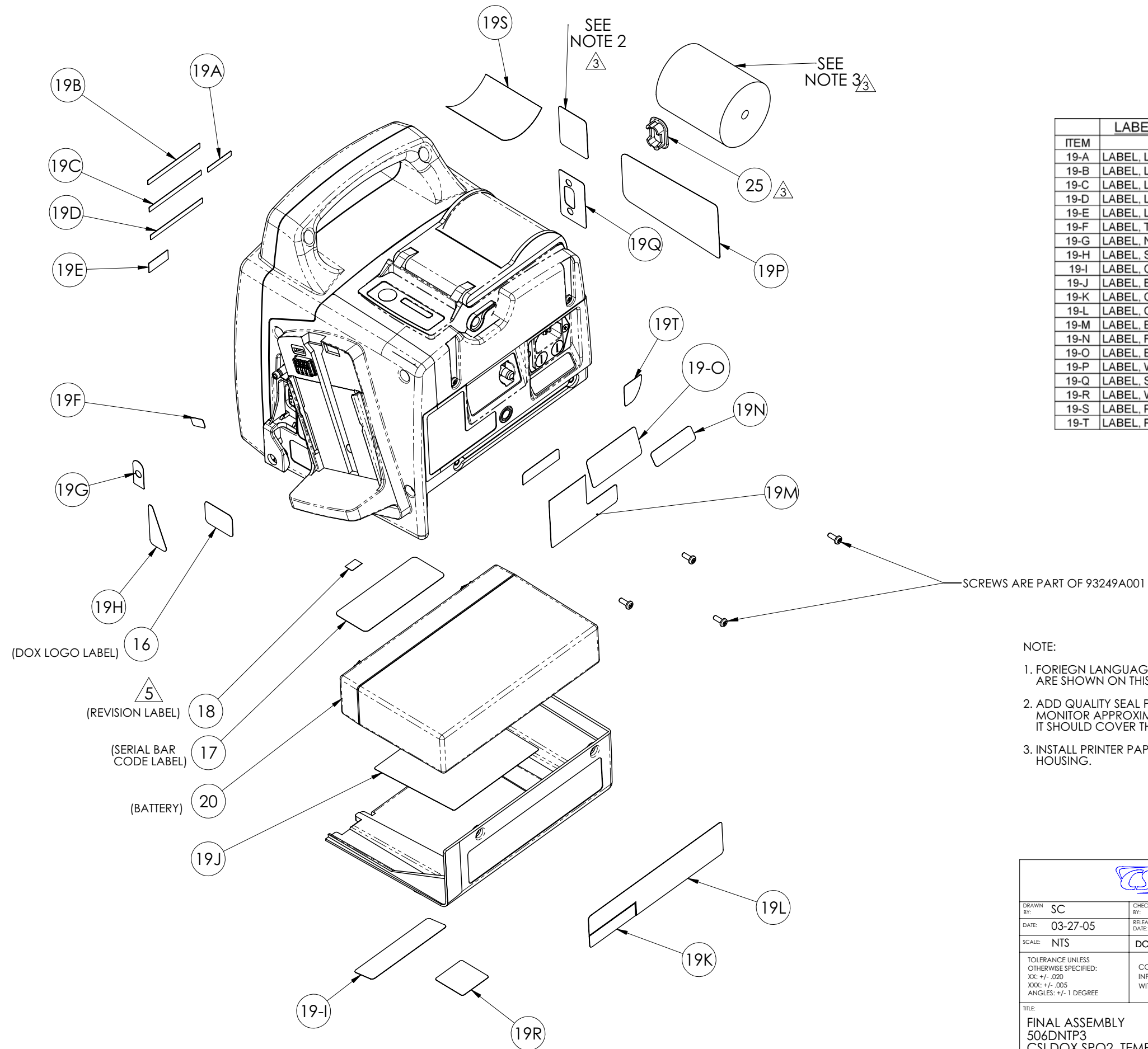

| LABELS FROM SET (ITEM 19) | |
|---------------------------|----------------------------------|
| ITEM | DESCRIPTION |
| 19-A | LABEL, LANGUAGE, MENU |
| 19-B | LABEL, LANGUAGE, TREND/PRINT |
| 19-C | LABEL, LANGUAGE, NIBP CYCLE |
| 19-D | LABEL, LANGUAGE, NIBP START/STAT |
| 19-E | LABEL, LANGUAGE, TEMP. ORAL/AX |
| 19-F | LABEL, TEMP. COVER |
| 19-G | LABEL, NIBP FITTING |
| 19-H | LABEL, SPO2 CONN. |
| 19-I | LABEL, CSI PATENT |
| 19-J | LABEL, BATTERY INSTALL |
| 19-K | LABEL, COUNTRY OF ORIGIN |
| 19-L | LABEL, CSI SUPPORT INFO |
| 19-M | LABEL, ETL SYMBOL |
| 19-N | LABEL, FUSE RATING |
| 19-O | LABEL, ELECTRICAL RATING |
| 19-P | LABEL, WARNINGS |
| 19-Q | LABEL, SERIAL PORT |
| 19-R | LABEL, WEEE DIRECTIVE |
| 19-S | LABEL, PAPER LOADING |
| 19-T | LABEL, PAPER RELEASE |

NOTE:

1. FOREIGN LANGUAGE LABELS INSTALLED AT THE CAT LEVEL. THEY ARE SHOWN ON THIS DRAWING FOR REFERENCE ONLY.
2. ADD QUALITY SEAL PN: 46036B101 (FROM CAT LEVEL BOM) TO MONITOR APPROXIMATELY ONE INCH ABOVE THE SERIAL PORT. IT SHOULD COVER THE FRONT AND REAR HOUSINGS.
3. INSTALL PRINTER PAPER PN: 40065B002 (CAT LEVEL) INTO PRINTER HOUSING.

SW

| | | |
|--|--------------------|--|
| | | |
| DRAWN BY: SC | CHECK BY: | ENG. APPR.: |
| DATE: 03-27-05 | RELEASE DATE: | Q.A. APPR.: |
| SCALE: NTS | DO NOT SCALE PRINT | |
| TOLERANCE UNLESS OTHERWISE SPECIFIED: XX: +/- .020 XXX: +/- .005 ANGLES: +/- 1 DEGREE | | CONFIDENTIAL: THIS DOCUMENT CONTAINS CONFIDENTIAL INFORMATION AND MAY NOT BE COPIED OR DIVULGED WITHOUT WRITTEN CONSENT OF CRITICARE SYSTEMS, INC. |
| TITLE: FINAL ASSEMBLY 506DNTP3 CSI DOX SPO2, TEMP., PRINTER | | PART NO.: 93975A004 |
| DIST: 302 | | REV.: 5 |
| SHEET 2 OF 2 | | |

| REVISIONS | | | |
|-----------|----------|---------------|-----|
| REV. | DATE | DESCRIPTION | BY |
| 1 | 09-01-05 | SEE ECN #8496 | SC |
| 2 | 11/18/05 | SEE ECN #8590 | DBL |
| 3 | 01/26/06 | SEE ECN #8652 | TLR |
| 4 | 06/28/06 | SEE ECN #8670 | SC |
| 5 | 12/7/06 | SEE ECN #8922 | DBL |

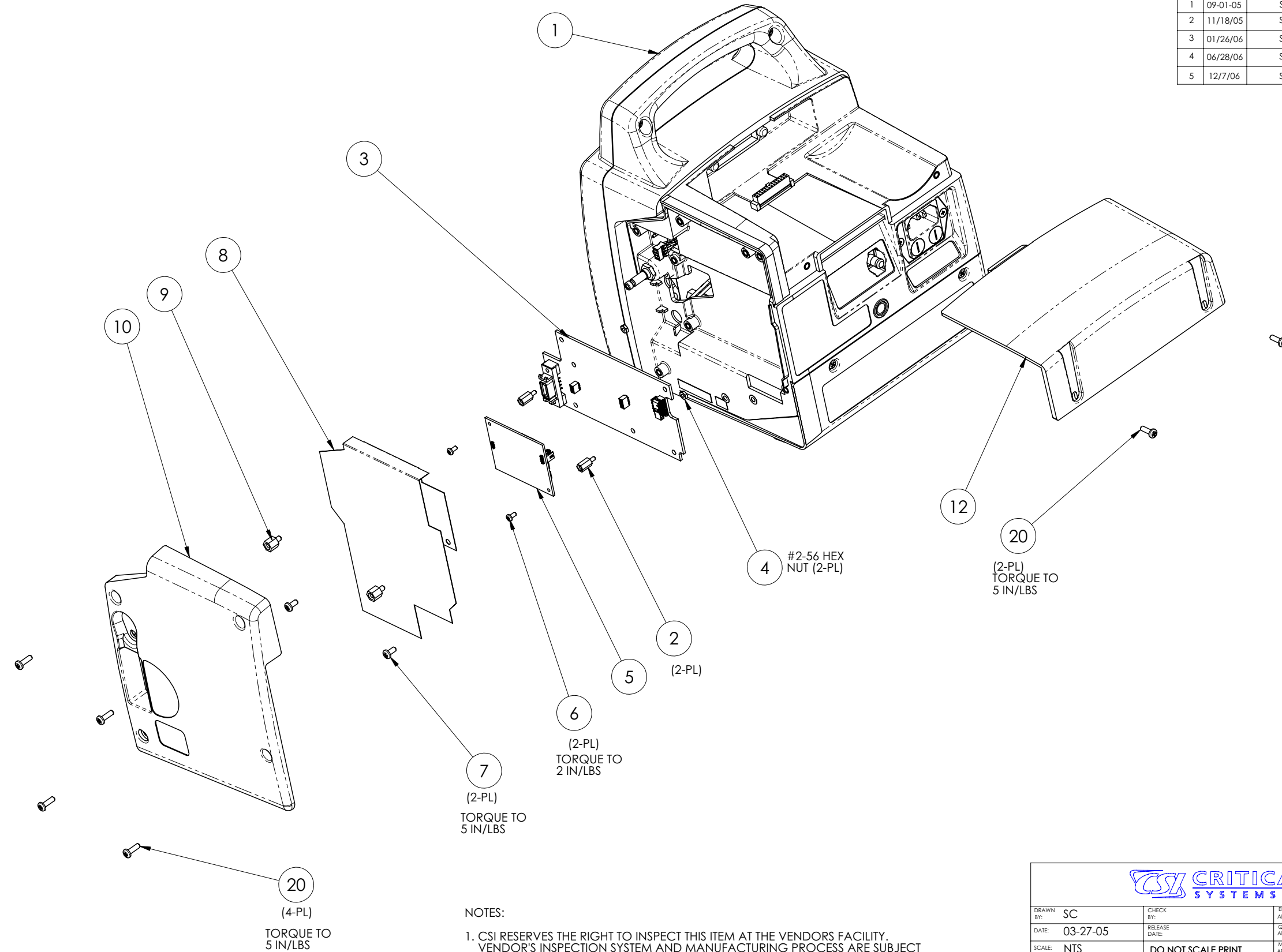

SW

NOTES:

1. CSI RESERVES THE RIGHT TO INSPECT THIS ITEM AT THE VENDORS FACILITY. VENDOR'S INSPECTION SYSTEM AND MANUFACTURING PROCESS ARE SUBJECT TO REVIEW/APPROVAL, VERIFICATION AND ANALYSIS BY AUTHORIZED CSI REPRESENTATIVES. ALL CHANGES IN DESIGN, COMPONENTS, PROCESSES OR FABRICATION MUST BE AUTHORIZED IN WRITING BY CSI PRIOR TO IMPLEMENTATION. ALL DEVIATIONS FROM DRAWINGS, SPECIFICATIONS, OR OTHER REQUIREMENTS MUST BE REPORTED TO CSI FOR APPROVAL PRIOR TO SHIPMENT.

| DRAWN BY: SC | CHECK BY: | ENG. APPR.: S. COOGAN 7/21/05 |
|--|--------------------|--|
| DATE: 03-27-05 | RELEASE DATE: | Q.A. APPR.: A. KAPLAN 7/21/05 |
| SCALE: NTS | DO NOT SCALE PRINT | MFG. APPR.: B. LEWANDOWSKI 7/25/05 |
| TOLERANCE UNLESS OTHERWISE SPECIFIED: XX: +/- .020 XXX: +/- .005 ANGLES: +/- 1 DEGREE | | CONFIDENTIAL: THIS DOCUMENT CONTAINS CONFIDENTIAL INFORMATION AND MAY NOT BE COPIED OR DIVULGED WITHOUT WRITTEN CONSENT OF CRITICARE SYSTEMS, INC. |
| TITLE: FINAL ASSEMBLY 506LN3 NELLCOR SPO2 | | PART NO.: 93975A005 REV.: 5 |
| DIST: 302 | | SHEET 1 OF 2 |

| REVISIONS | | | |
|-----------|------|-------------|----|
| REV. | DATE | DESCRIPTION | BY |
| | | | |

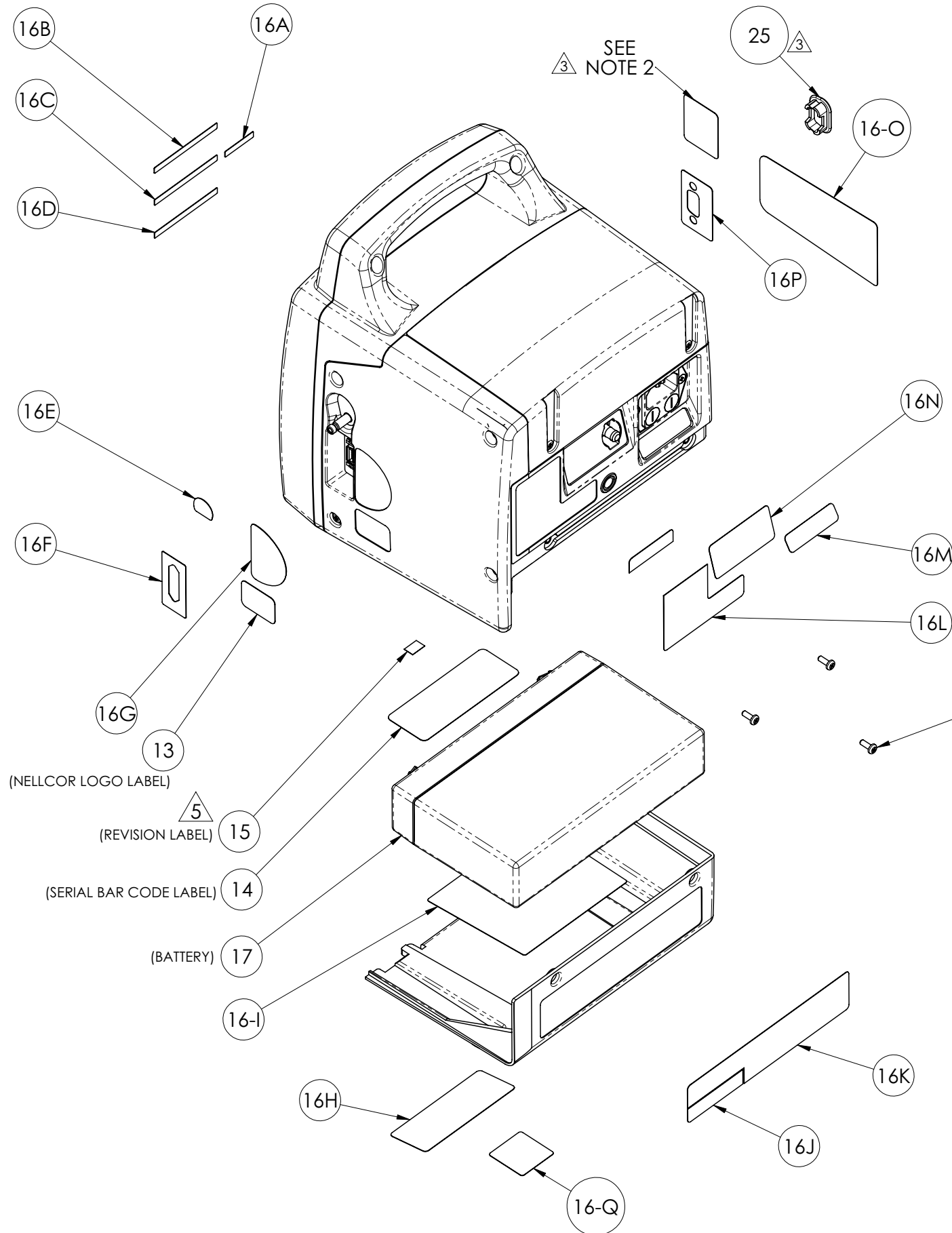

LABELS FROM SET (ITEM 16)

| ITEM | DESCRIPTION |
|------|----------------------------------|
| 16-A | LABEL, LANGUAGE, MENU |
| 16-B | LABEL, LANGUAGE, TREND/PRINT |
| 16-C | LABEL, LANGUAGE, NIBP CYCLE |
| 16-D | LABEL, LANGUAGE, NIBP START/STAT |
| 16-E | LABEL, NIBP FITTING (NON-TEMP) |
| 16-F | LABEL, SPO2 CONN. (NELLCOR) |
| 16-G | LABEL, SPO2 CONN. (NON-TEMP) |
| 16-H | LABEL, NELLCOR PATENT |
| 16-I | LABEL, BATTERY INSTALL |
| 16-J | LABEL, COUNTRY OF ORIGIN |
| 16-K | LABEL, CSI SUPPORT INFO |
| 16-L | LABEL, ETL SYMBOL |
| 16-M | LABEL, FUSE RATING |
| 16-N | LABEL, ELECTRICAL RATING |
| 16-O | LABEL, WARNINGS |
| 16-P | LABEL, SERIAL PORT |
| 16-Q | LABEL, WEEE DIRECTIVE |

(NELLCOR LOGO LABEL) 13
 (REVISION LABEL) 5 15
 (SERIAL BAR CODE LABEL) 14
 (BATTERY) 17

SCREWS ARE PART OF 93249A001

- NOTE:
1. FOREIGN LANGUAGE LABELS INSTALLED AT THE CAT LEVEL. THEY ARE SHOWN ON THIS DRAWING FOR REFERENCE ONLY.
 2. ADD QUALITY SEAL PN: 46036B101 (FROM CAT LEVEL BOM) TO MONITOR APPROXIMATELY ONE INCH ABOVE THE SERIAL PORT. IT SHOULD COVER THE FRONT AND REAR HOUSINGS.

SW

CRITICARE SYSTEMS, INC.

| | | |
|--|--------------------|--|
| DRAWN BY: SC | CHECK BY: | ENG. APPR.: |
| DATE: 03-27-05 | RELEASE DATE: | Q.A. APPR.: |
| SCALE: NTS | DO NOT SCALE PRINT | |
| TOLERANCE UNLESS OTHERWISE SPECIFIED: XX: +/- .020 XXX: +/- .005 ANGLES: +/- 1 DEGREE | | CONFIDENTIAL: THIS DOCUMENT CONTAINS CONFIDENTIAL INFORMATION AND MAY NOT BE COPIED OR DIVULGED WITHOUT WRITTEN CONSENT OF CRITICARE SYSTEMS, INC. |
| TITLE: FINAL ASSEMBLY 506LN3 NELLCOR SPO2 | | PART NO.: 93975A005 |
| DIST: 302 | | REV. 5 |

SHEET 2 OF 2

| REVISIONS | | | |
|-----------|----------|---------------|-----|
| REV. | DATE | DESCRIPTION | BY |
| 1 | 09-01-05 | SEE ECN #8496 | SC |
| 2 | 11/18/05 | SEE ECN #8590 | DBL |
| 3 | 01/31/06 | SEE ECN #8652 | TLR |
| 4 | 06/28/06 | SEE ECN #8670 | SC |
| 5 | 12/7/06 | SEE ECN #8922 | DBL |

NOTES:

1. CSI RESERVES THE RIGHT TO INSPECT THIS ITEM AT THE VENDORS FACILITY. VENDOR'S INSPECTION SYSTEM AND MANUFACTURING PROCESS ARE SUBJECT TO REVIEW/APPROVAL, VERIFICATION AND ANALYSIS BY AUTHORIZED CSI REPRESENTATIVES. ALL CHANGES IN DESIGN, COMPONENTS, PROCESSES OR FABRICATION MUST BE AUTHORIZED IN WRITING BY CSI PRIOR TO IMPLEMENTATION. ALL DEVIATIONS FROM DRAWINGS, SPECIFICATIONS, OR OTHER REQUIREMENTS MUST BE REPORTED TO CSI FOR APPROVAL PRIOR TO SHIPMENT.

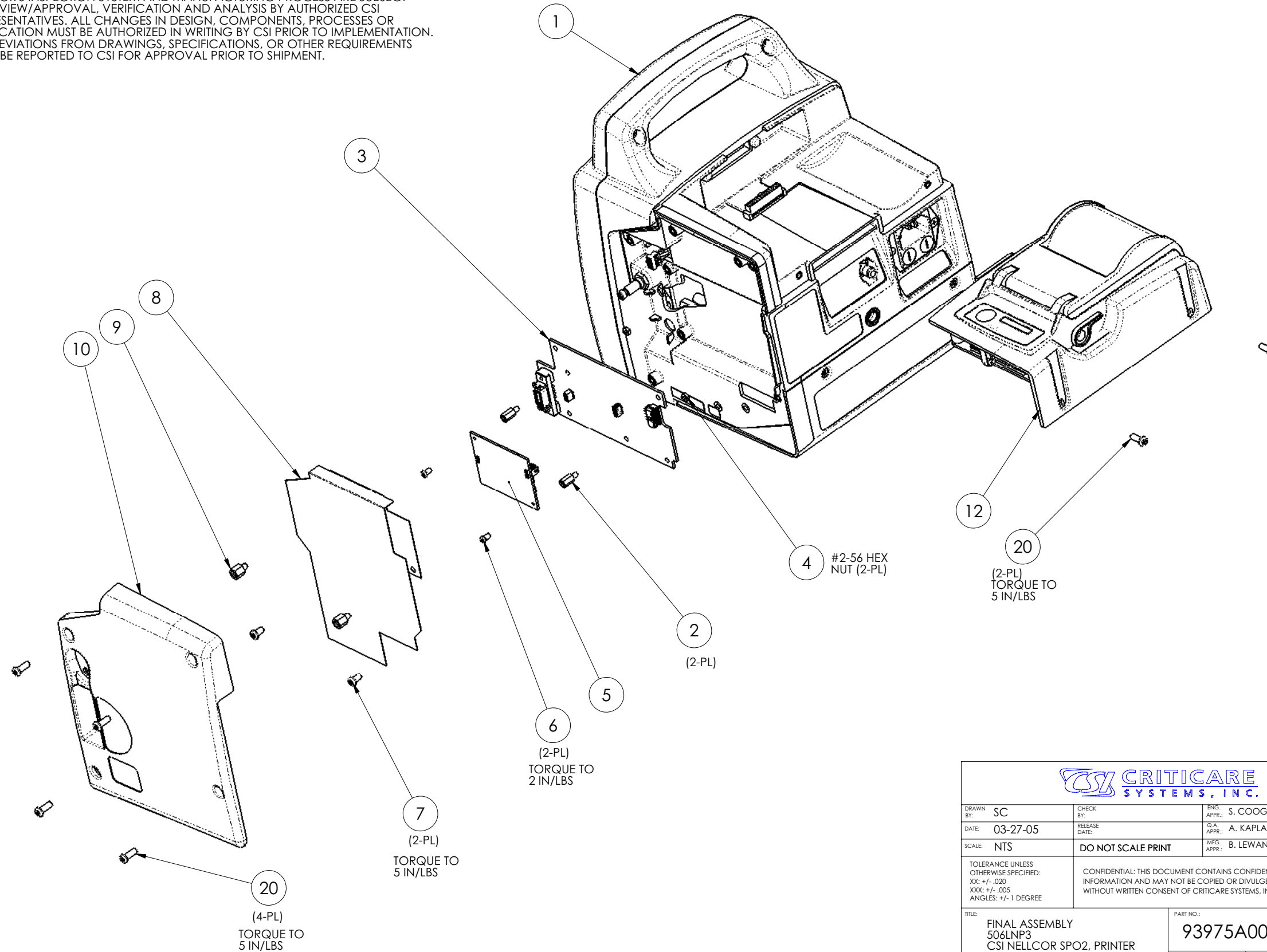

SW



| | | |
|--|--------------------|--|
| DRAWN BY: SC | CHECK BY: | ENG. APPR.: S. COOGAN 7/21/05 |
| DATE: 03-27-05 | RELEASE DATE: | Q.A. APPR.: A. KAPLAN 7/21/05 |
| SCALE: NTS | DO NOT SCALE PRINT | MFG. APPR.: B. LEWANDOWSKI 7/25/05 |
| TOLERANCE UNLESS OTHERWISE SPECIFIED: XX: +/- .020 XXX: +/- .005 ANGLES: +/- 1 DEGREE | | CONFIDENTIAL: THIS DOCUMENT CONTAINS CONFIDENTIAL INFORMATION AND MAY NOT BE COPIED OR DIVULGED WITHOUT WRITTEN CONSENT OF CRITICARE SYSTEMS, INC. |
| TITLE: FINAL ASSEMBLY 506LNP3 CSI NELLCOR SPO2, PRINTER | | PART NO.: 93975A006 |
| DIST: 302 | | REV. 5 |
| SHEET 1 OF 2 | | |

| REVISIONS | | | |
|-----------|------|-------------|----|
| REV. | DATE | DESCRIPTION | BY |
| | | | |

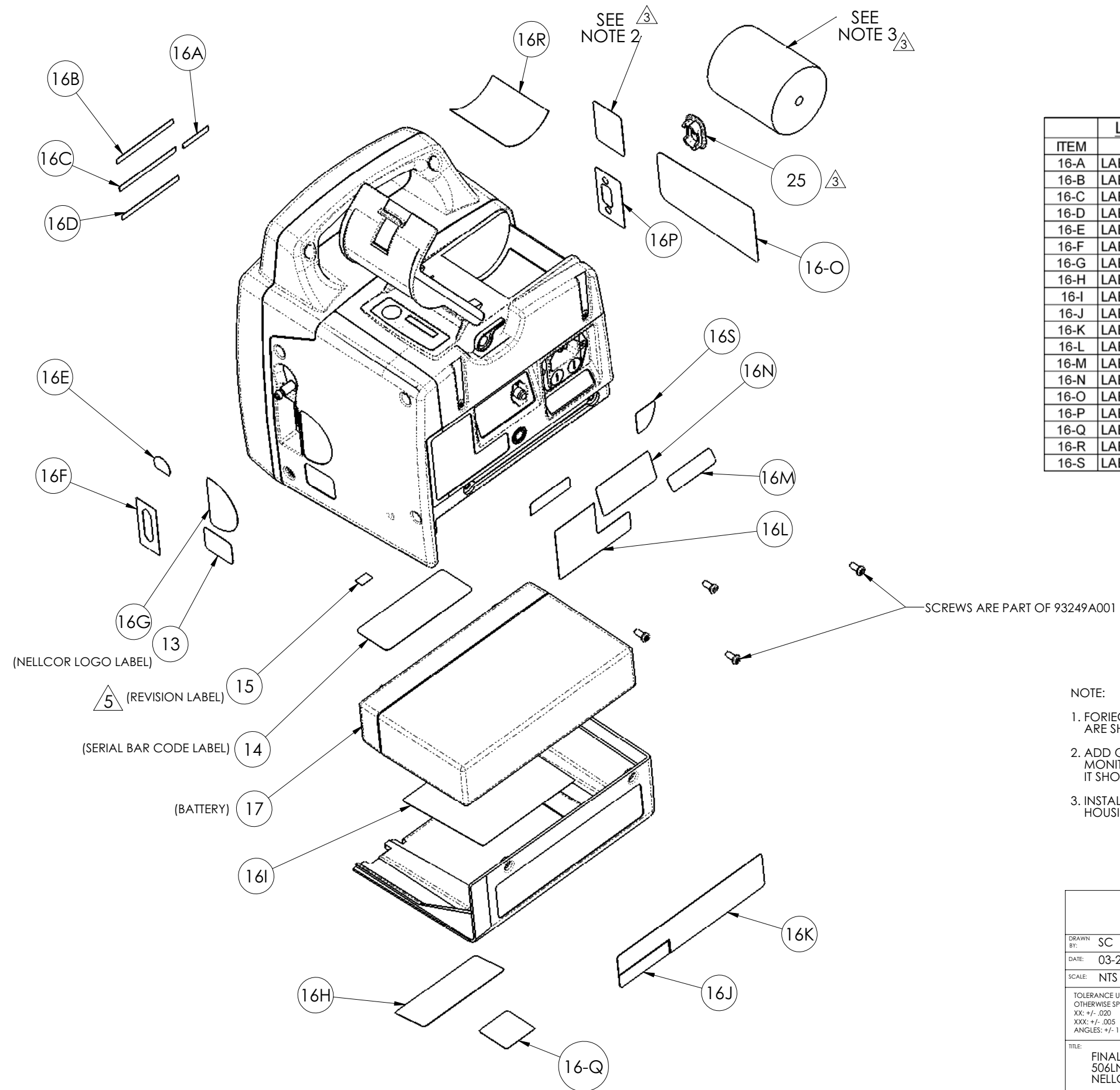

| LABELS FROM SET (ITEM 16) | |
|---------------------------|----------------------------------|
| ITEM | DESCRIPTION |
| 16-A | LABEL, LANGUAGE, MENU |
| 16-B | LABEL, LANGUAGE, TREND/PRINT |
| 16-C | LABEL, LANGUAGE, NIBP CYCLE |
| 16-D | LABEL, LANGUAGE, NIBP START/STAT |
| 16-E | LABEL, NIBP FITTING (NON-TEMP) |
| 16-F | LABEL, SPO2 CONN. (NELLCOR) |
| 16-G | LABEL, SPO2 CONN. (NON-TEMP) |
| 16-H | LABEL, NELLCOR PATENT |
| 16-I | LABEL, BATTERY INSTALL |
| 16-J | LABEL, COUNTRY OF ORIGIN |
| 16-K | LABEL, CSI SUPPORT INFO |
| 16-L | LABEL, ETL SYMBOL |
| 16-M | LABEL, FUSE RATING |
| 16-N | LABEL, ELECTRICAL RATING |
| 16-O | LABEL, WARNINGS |
| 16-P | LABEL, SERIAL PORT |
| 16-Q | LABEL, WEEE DIRECTIVE |
| 16-R | LABEL, PAPER LOADING |
| 16-S | LABEL, PAPER RELEASE |

SCREWS ARE PART OF 93249A001

NOTE:

1. FOREIGN LANGUAGE LABELS INSTALLED AT THE CAT LEVEL. THEY ARE SHOWN ON THIS DRAWING FOR REFERENCE ONLY.
2. ADD QUALITY SEAL PN: 46036B101 (FROM CAT LEVEL BOM) TO MONITOR APPROXIMATELY ONE INCH ABOVE THE SERIAL PORT. IT SHOULD COVER THE FRONT AND REAR HOUSINGS.
3. INSTALL PRINTER PAPER PN: 40065B002 (CAT LEVEL) INTO PRINTER HOUSING.

SW

| | | |
|--|--------------------|--|
| | | |
| DRAWN BY: SC | CHECK BY: | ENG. APPR.: |
| DATE: 03-27-05 | RELEASE DATE: | Q.A. APPR.: |
| SCALE: NTS | DO NOT SCALE PRINT | |
| TOLERANCE UNLESS OTHERWISE SPECIFIED: XX: +/- .020 XXX: +/- .005 ANGLES: +/- 1 DEGREE | | CONFIDENTIAL: THIS DOCUMENT CONTAINS CONFIDENTIAL INFORMATION AND MAY NOT BE COPIED OR DIVULGED WITHOUT WRITTEN CONSENT OF CRITICARE SYSTEMS, INC. |
| TITLE: FINAL ASSEMBLY 506LNP3 NELLCOR SPO2, PRINTER | | PART NO.: 93975A006 |
| DIST: 302 | | REV. 5 |
| SHEET 2 OF 2 | | |

NOTES:

1. CSI RESERVES THE RIGHT TO INSPECT THIS ITEM AT THE VENDORS FACILITY. VENDOR'S INSPECTION SYSTEM AND MANUFACTURING PROCESS ARE SUBJECT TO REVIEW/APPROVAL, VERIFICATION AND ANALYSIS BY AUTHORIZED CSI REPRESENTATIVES. ALL CHANGES IN DESIGN, COMPONENTS, PROCESSES OR FABRICATION MUST BE AUTHORIZED IN WRITING BY CSI PRIOR TO IMPLEMENTATION. ALL DEVIATIONS FROM DRAWINGS, SPECIFICATIONS, OR OTHER REQUIREMENTS MUST BE REPORTED TO CSI FOR APPROVAL PRIOR TO SHIPMENT.

| REVISIONS | | | |
|-----------|----------|---------------|-----|
| REV. | DATE | DESCRIPTION | BY |
| 1 | 09-01-05 | SEE ECN #8496 | SC |
| 2 | 11/18/05 | SEE ECN #8590 | DBL |
| 3 | 01/30/06 | SEE ECN #8652 | TLR |
| 4 | 06/28/06 | SEE ECN #8670 | SC |
| 5 | 12/7/06 | SEE ECN #8922 | DBL |

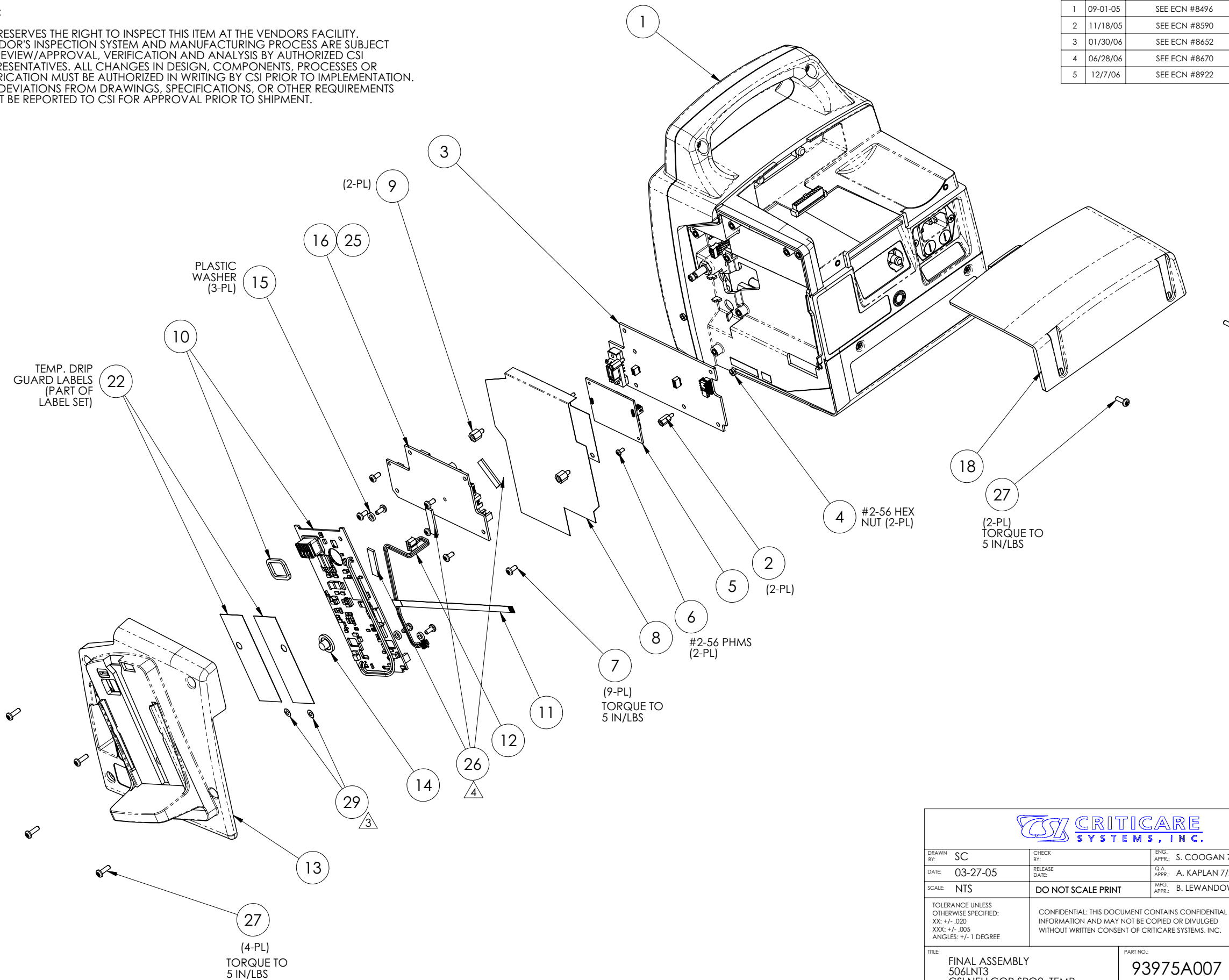

SW

| | | |
|--|--------------------|--|
| | | |
| DRAWN BY: SC | CHECK BY: | ENG. APPR.: S. COOGAN 7/21/05 |
| DATE: 03-27-05 | RELEASE DATE: | Q.A. APPR.: A. KAPLAN 7/21/05 |
| SCALE: NTS | DO NOT SCALE PRINT | MFG. APPR.: B. LEWANDOWSKI 7/25/05 |
| TOLERANCE UNLESS OTHERWISE SPECIFIED: XX: +/- .020 XXX: +/- .005 ANGLES: +/- 1 DEGREE | | CONFIDENTIAL: THIS DOCUMENT CONTAINS CONFIDENTIAL INFORMATION AND MAY NOT BE COPIED OR DIVULGED WITHOUT WRITTEN CONSENT OF CRITICARE SYSTEMS, INC. |
| TITLE: FINAL ASSEMBLY 506LNT3 CSI NELLCOR SPO2, TEMP | | PART NO.: 93975A007 |
| | | REV. 5 |
| DIST: 302 | | SHEET 1 OF 2 |

| REVISIONS | | | |
|-----------|------|-------------|----|
| REV. | DATE | DESCRIPTION | BY |
| | | | |

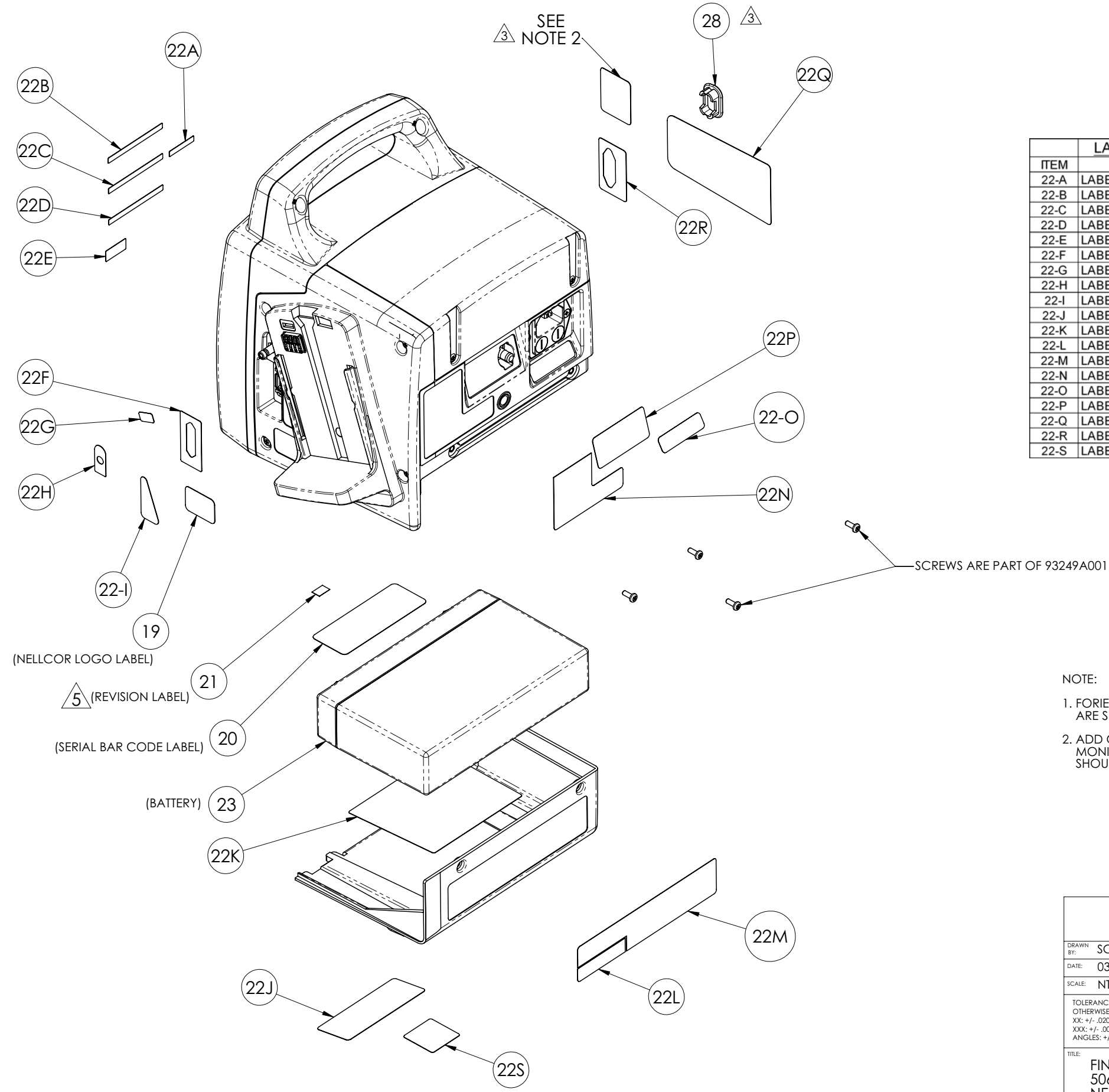

| LABELS FROM SET (ITEM 22) | |
|---------------------------|----------------------------------|
| ITEM | DESCRIPTION |
| 22-A | LABEL, LANGUAGE, MENU |
| 22-B | LABEL, LANGUAGE, TREND/PRINT |
| 22-C | LABEL, LANGUAGE, NIBP CYCLE |
| 22-D | LABEL, LANGUAGE, NIBP START/STAT |
| 22-E | LABEL, LANGUAGE, TEMP ORAL/AX |
| 22-F | LABEL, SPO2 CONN. (NELLCOR) |
| 22-G | LABEL, TEMP COVER |
| 22-H | LABEL, NIBP FITTING (TEMP) |
| 22-I | LABEL, SPO2 CONN. |
| 22-J | LABEL, NELLCOR PATENT |
| 22-K | LABEL, BATTERY INSTALL |
| 22-L | LABEL, COUNTRY OF ORIGIN |
| 22-M | LABEL, CSI SUPPORT INFO |
| 22-N | LABEL, ETL SYMBOL |
| 22-O | LABEL, FUSE RATING |
| 22-P | LABEL, ELECTRICAL RATING |
| 22-Q | LABEL, WARNINGS |
| 22-R | LABEL, SERIAL PORT |
| 22-S | LABEL, WEEE DIRECTIVE |

NOTE:

- FORIEGN LANGUAGE LABELS INSTALLED AT THE CAT LEVEL. THEY ARE SHOWN ON THIS DRAWING FOR REFERENCE ONLY.
- ADD QUALITY SEAL PN: 46036B101 (FROM CAT LEVEL BOM) TO MONITOR APPROXIMATELY ONE INCH ABOVE THE SERIAL PORT. IT SHOULD COVER THE FRONT AND REAR HOUSINGS.

SW

| | | |
|--|---------------------|--|
| | | |
| DRAWN BY: SC | CHECK BY: | ENG. APPR.: |
| DATE: 03-27-05 | RELEASE DATE: | Q.A. APPR.: |
| SCALE: NT3 | DO NOT SCALE PRINT | MFG. APPR.: |
| TOLERANCE UNLESS OTHERWISE SPECIFIED: XX: +/- .020 XXX: +/- .005 ANGLES: +/- 1 DEGREE | | CONFIDENTIAL: THIS DOCUMENT CONTAINS CONFIDENTIAL INFORMATION AND MAY NOT BE COPIED OR DIVULGED WITHOUT WRITTEN CONSENT OF CRITICARE SYSTEMS, INC. |
| TITLE: FINAL ASSEMBLY 506LNT3 NELLCOR SPO2, TEMP | PART NO.: 93975A007 | REV. 5 |
| DIST: 302 | SHEET 2 OF 2 | |

NOTES:

1. CSI RESERVES THE RIGHT TO INSPECT THIS ITEM AT THE VENDORS FACILITY. VENDOR'S INSPECTION SYSTEM AND MANUFACTURING PROCESS ARE SUBJECT TO REVIEW/APPROVAL, VERIFICATION AND ANALYSIS BY AUTHORIZED CSI REPRESENTATIVES. ALL CHANGES IN DESIGN, COMPONENTS, PROCESSES OR FABRICATION MUST BE AUTHORIZED IN WRITING BY CSI PRIOR TO IMPLEMENTATION. ALL DEVIATIONS FROM DRAWINGS, SPECIFICATIONS, OR OTHER REQUIREMENTS MUST BE REPORTED TO CSI FOR APPROVAL PRIOR TO SHIPMENT.

| REVISIONS | | | |
|-----------|----------|---------------|-----|
| REV. | DATE | DESCRIPTION | BY |
| 1 | 09-01-05 | SEE ECN #8496 | SC |
| 2 | 11/18/05 | SEE ECN #8590 | DBL |
| 3 | 01/31/06 | SEE ECN #8652 | TLR |
| 4 | 3/27/06 | SEE ECN #8761 | DBL |
| 5 | 6/28/06 | SEE ECN #8670 | SC |
| 6 | 12/7/06 | SEE ECN #8922 | DBL |

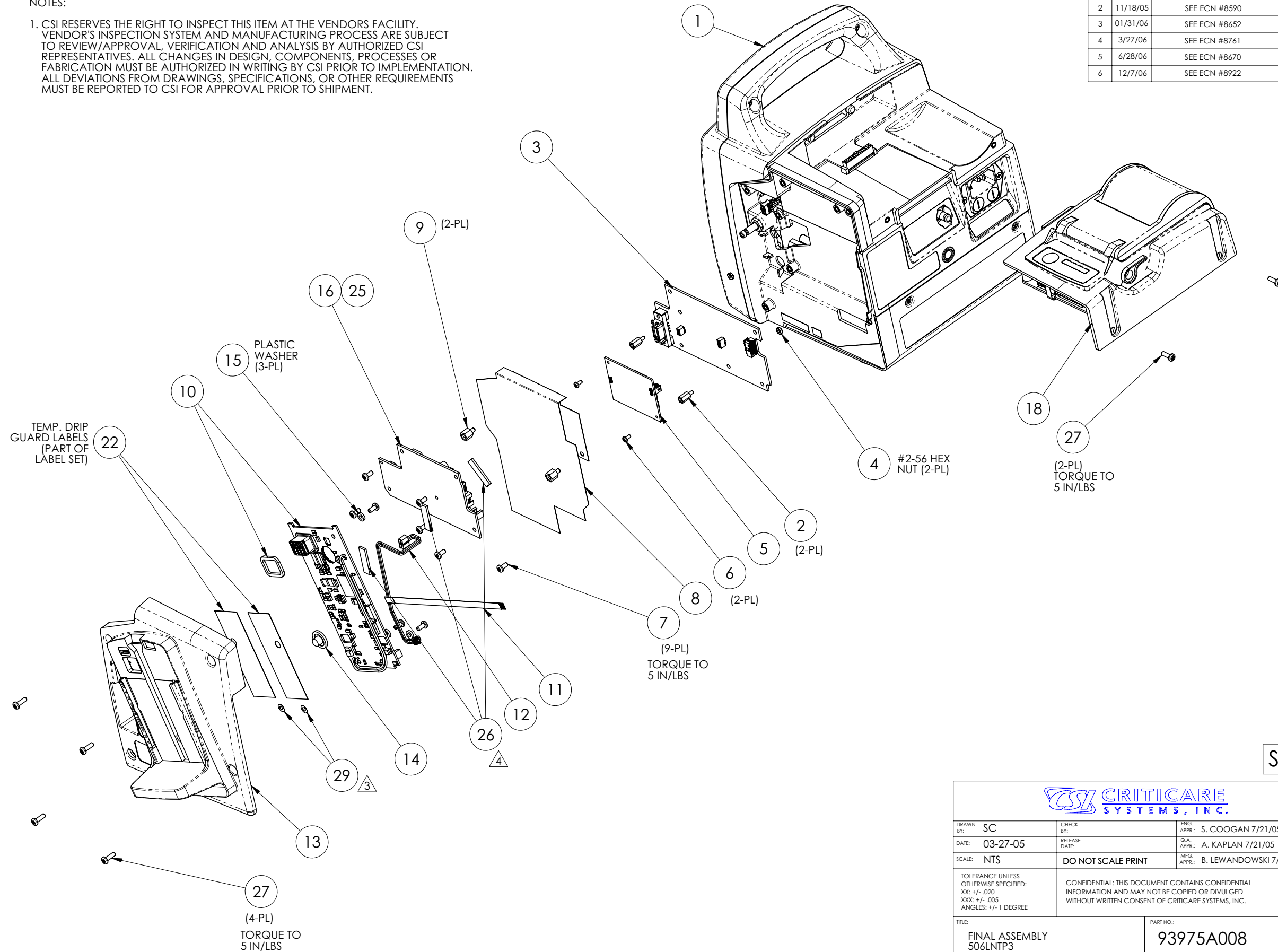

SW



| | | |
|--|--------------------|--|
| DRAWN BY: SC | CHECK BY: | ENG. APPR.: S. COOGAN 7/21/05 |
| DATE: 03-27-05 | RELEASE DATE: | G.A. APPR.: A. KAPLAN 7/21/05 |
| SCALE: NTS | DO NOT SCALE PRINT | MFG. APPR.: B. LEWANDOWSKI 7/25/05 |
| TOLERANCE UNLESS OTHERWISE SPECIFIED: XX: +/- .020 XXX: +/- .005 ANGLES: +/- 1 DEGREE | | CONFIDENTIAL: THIS DOCUMENT CONTAINS CONFIDENTIAL INFORMATION AND MAY NOT BE COPIED OR DIVULGED WITHOUT WRITTEN CONSENT OF CRITICARE SYSTEMS, INC. |
| TITLE: FINAL ASSEMBLY 506LNT3 CSI NELLCOR SPO2, TEMP, PRNTR | | PART NO.: 93975A008 |
| DIST: 302 | | REV. 6 |
| SHEET 1 OF 2 | | |

| REVISIONS | | | |
|-----------|------|-------------|----|
| REV. | DATE | DESCRIPTION | BY |
| | | | |

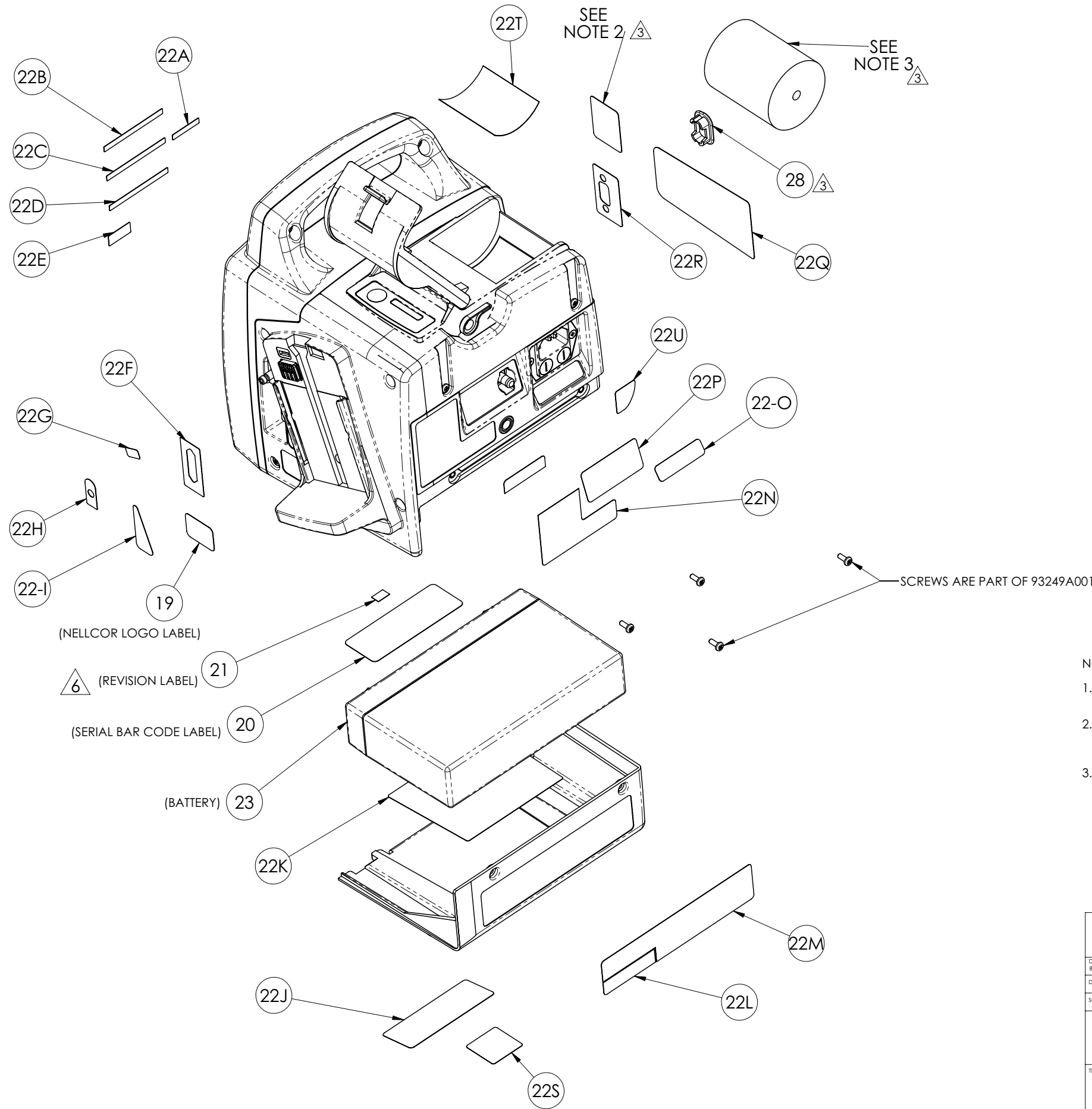

| LABELS FROM SET (ITEM 22) | |
|---------------------------|----------------------------------|
| ITEM | DESCRIPTION |
| 22-A | LABEL, LANGUAGE, MENU |
| 22-B | LABEL, LANGUAGE, TREND/PRINT |
| 22-C | LABEL, LANGUAGE, NIBP CYCLE |
| 22-D | LABEL, LANGUAGE, NIBP START/STAT |
| 22-E | LABEL, LANGUAGE, TEMP ORAL/AX |
| 22-F | LABEL, SPO2 CONN. (NELLCOR) |
| 22-G | LABEL, TEMP COVER |
| 22-H | LABEL, NIBP FITTING (TEMP) |
| 22-I | LABEL, SPO2 CONN. |
| 22-J | LABEL, NELLCOR PATENT |
| 22-K | LABEL, BATTERY INSTALL |
| 22-L | LABEL, COUNTRY OF ORIGIN |
| 22-M | LABEL, CSI SUPPORT INFO |
| 22-N | LABEL, ETL SYMBOL |
| 22-O | LABEL, FUSE RATING |
| 22-P | LABEL, ELECTRICAL RATING |
| 22-Q | LABEL, WARNINGS |
| 22-R | LABEL, SERIAL PORT |
| 22-S | LABEL, WEEE DIRECTIVE |
| 22-T | LABEL, PAPER LOADING |
| 22-U | LABEL, PAPER RELEASE |

NOTE:

1. FOREIGN LANGUAGE LABELS INSTALLED AT THE CAT LEVEL. THEY ARE SHOWN ON THIS DRAWING FOR REFERENCE ONLY.
2. ADD QUALITY SEAL PN: 46036B101 (FROM CAT LEVEL BOM) TO MONITOR APPROXIMATELY ONE INCH ABOVE THE SERIAL PORT. IT SHOULD COVER THE FRONT AND REAR HOUSINGS.
3. INSTALL PRINTER PAPER PN: 40065B002 (CAT LEVEL) INTO PRINTER HOUSING.

SW

| | | |
|--|--------------------|--|
| | | |
| DRAWN BY: SC | CHECK BY: | ENG. APPR.: |
| DATE: 03-27-05 | RELEASE DATE: | Q.A. APPR.: |
| SCALE: NTS | DO NOT SCALE PRINT | |
| TOLERANCE UNLESS OTHERWISE SPECIFIED: XX: +/- .020 XXX: +/- .005 ANGLES: +/- 1 DEGREE | | CONFIDENTIAL: THIS DOCUMENT CONTAINS CONFIDENTIAL INFORMATION AND MAY NOT BE COPIED OR DIVULGED WITHOUT WRITTEN CONSENT OF CRITICARE SYSTEMS, INC. |
| TITLE: FINAL ASSEMBLY 506LNT3 NELLCOR SPO2, TEMP, PRNTR | | PART NO.: 93975A008 |
| | | REV. 6 |
| DST: 302 | | SHEET 2 OF 2 |

| REVISIONS | | | |
|-----------|---------|---------------|-----|
| REV. | DATE | DESCRIPTION | BY |
| 1 | 12/8/06 | SEE ECN #8922 | DBL |

TEMPERATURE CONNECTOR

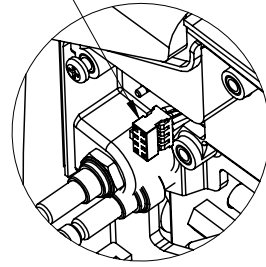

DETAIL A

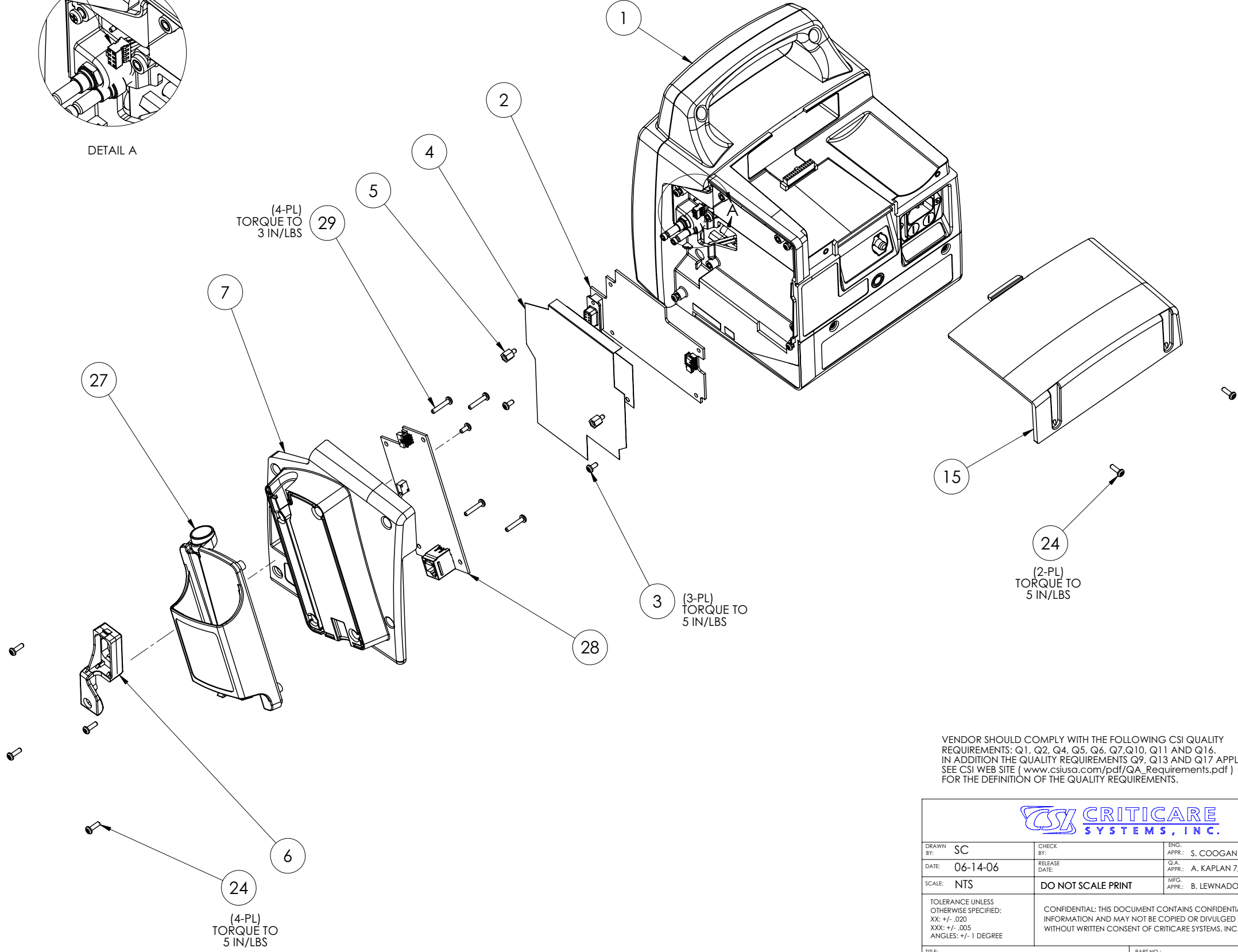

VENDOR SHOULD COMPLY WITH THE FOLLOWING CSI QUALITY REQUIREMENTS: Q1, Q2, Q4, Q5, Q6, Q7, Q10, Q11 AND Q16. IN ADDITION THE QUALITY REQUIREMENTS Q9, Q13 AND Q17 APPLY. SEE CSI WEB SITE (www.csiusa.com/pdf/QA_Requirements.pdf) FOR THE DEFINITION OF THE QUALITY REQUIREMENTS.

SW



| | | |
|--|--------------------|--|
| DRAWN BY: SC | CHECK BY: | ENG. APPR.: S. COOGAN 7/27/06 |
| DATE: 06-14-06 | RELEASE DATE: | Q.A. APPR.: A. KAPLAN 7/31/06 |
| SCALE: NTS | DO NOT SCALE PRINT | MFG. APPR.: B. LEWNADOWSKI 7/25/06 |
| TOLERANCE UNLESS OTHERWISE SPECIFIED: XX: +/- .020 XXX: +/- .005 ANGLES: +/- 1 DEGREE | | CONFIDENTIAL: THIS DOCUMENT CONTAINS CONFIDENTIAL INFORMATION AND MAY NOT BE COPIED OR DIVULGED WITHOUT WRITTEN CONSENT OF CRITICARE SYSTEMS, INC. |
| TITLE: FINAL ASSEMBLY 506DNI3 CSI DOX SPO2, TURBO TEMP | | PART NO.: 93975A009 |
| DIST: 302 | | REV. 1 |
| SHEET 1 OF 2 | | |

| REVISIONS | | | |
|-----------|------|-------------|----|
| REV. | DATE | DESCRIPTION | BY |
| | | | |

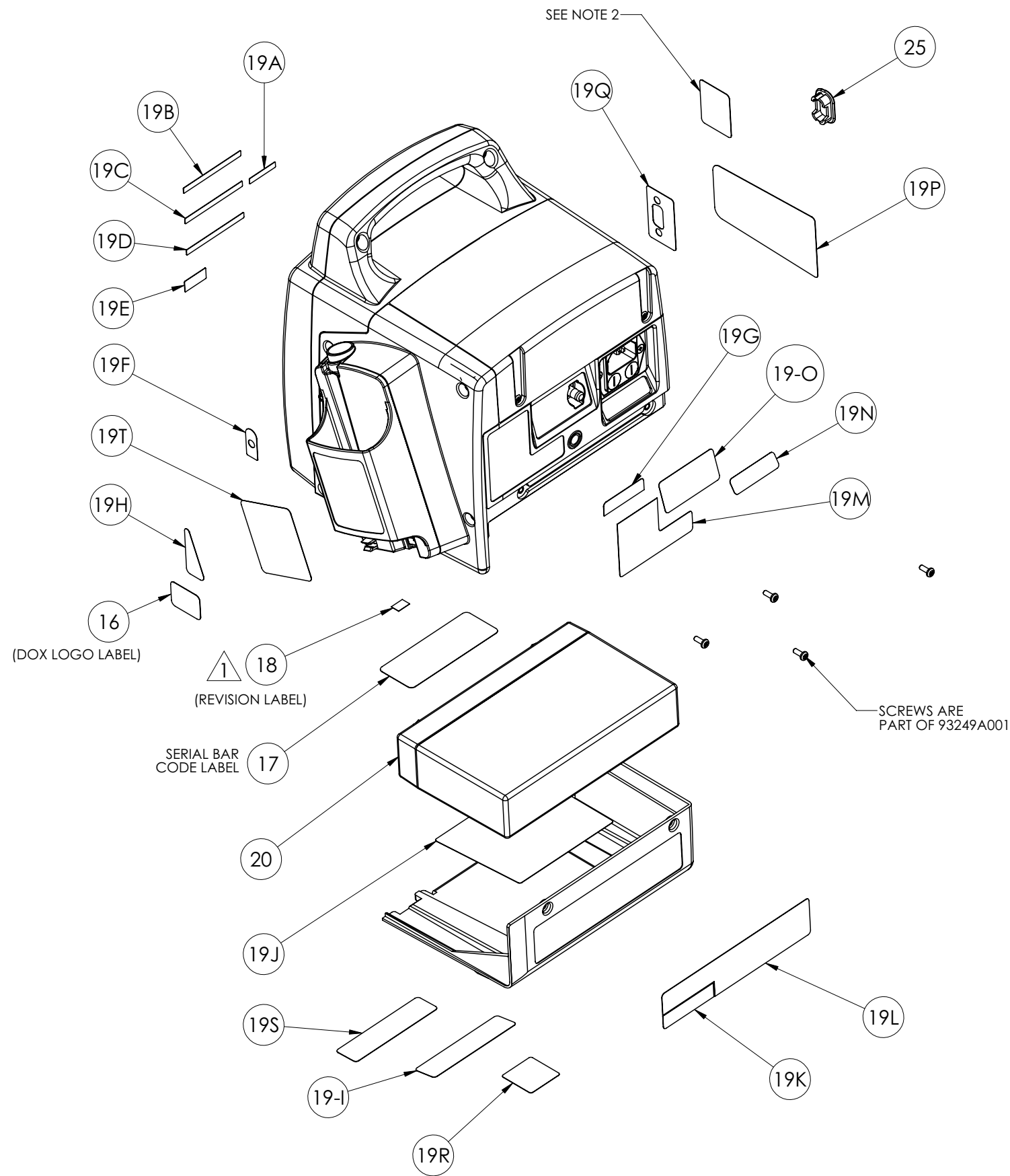

| LABELS FROM SET (ITEM 19) | |
|---------------------------|----------------------------------|
| ITEM | DESCRIPTION |
| 19-A | LABEL, LANGUAGE, MENU |
| 19-B | LABEL, LANGUAGE, TREND/PRINT |
| 19-C | LABEL, LANGUAGE, NIBP CYCLE |
| 19-D | LABEL, LANGUAGE, NIBP START/STAT |
| 19-E | LABEL, LANGUAGE, TEMP. ORAL/AX |
| 19-F | LABEL, NIBP FITTING |
| 19-G | LABEL, BLANK |
| 19-H | LABEL, SPO2 CONN. |
| 19-I | LABEL, CSI PATENT |
| 19-J | LABEL, BATTERY INSTALL |
| 19-K | LABEL, COUNTRY OF ORIGIN |
| 19-L | LABEL, CSI SUPPORT INFO |
| 19-M | LABEL, ETL SYMBOL |
| 19-N | LABEL, FUSE RATING |
| 19-O | LABEL, ELECTRICAL RATING |
| 19-P | LABEL, WARNINGS |
| 19-Q | LABEL, SERIAL PORT |
| 19-R | LABEL, WEEE DIRECTIVE |
| 19-S | LABEL, ALARIS PATENT |
| 19-T | LABEL, ALARIS TURBO TEMP |

NOTE:

1. FOREIGN LANGUAGE LABELS INSTALLED AT THE CAT LEVEL. THEY ARE SHOWN ON THIS DRAWING FOR REFERENCE ONLY.
2. ADD QUALITY SEAL PN: 46036B101 (FROM CAT LEVEL BOM) TO MONITOR APPROXIMATELY ONE INCH ABOVE THE SERIAL PORT. IT SHOULD COVER THE FRONT AND REAR HOUSINGS.

VENDOR SHOULD COMPLY WITH THE FOLLOWING CSI QUALITY REQUIREMENTS: Q1, Q2, Q4, Q5, Q6, Q7, Q10, Q11 AND Q16. IN ADDITION THE QUALITY REQUIREMENTS Q9, Q13 AND Q17 APPLY. SEE CSI WEB SITE (www.csiusa.com/pdf/QA_Requirements.pdf) FOR THE DEFINITION OF THE QUALITY REQUIREMENTS.

SW

| | | |
|--|--------------------|--|
| CSI CRITICARE SYSTEMS, INC. | | |
| DRAWN BY: SC | CHECK BY: | ENG. APPR.: |
| DATE: 06-14-06 | RELEASE DATE: | Q.A. APPR.: |
| SCALE: NTS | DO NOT SCALE PRINT | |
| TOLERANCE UNLESS OTHERWISE SPECIFIED: XX: +/- .020 XXX: +/- .005 ANGLES: +/- 1 DEGREE | | CONFIDENTIAL: THIS DOCUMENT CONTAINS CONFIDENTIAL INFORMATION AND MAY NOT BE COPIED OR DIVULGED WITHOUT WRITTEN CONSENT OF CRITICARE SYSTEMS, INC. |
| TITLE: FINAL ASSEMBLY 506DNY3 CSI DOX SPO2, TURBO TEMP | | PART NO.: 93975A009 |
| DIST: 302 | | REV. 1 |
| SHEET 2 OF 2 | | |

| REVISIONS | | | |
|-----------|---------|---------------|-----|
| REV. | DATE | DESCRIPTION | BY |
| 1 | 12/8/06 | SEE ECN #8922 | DBL |

TEMPERATURE CONNECTOR

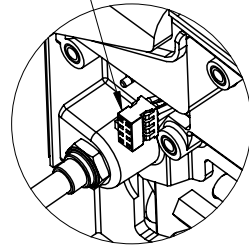

DETAIL A

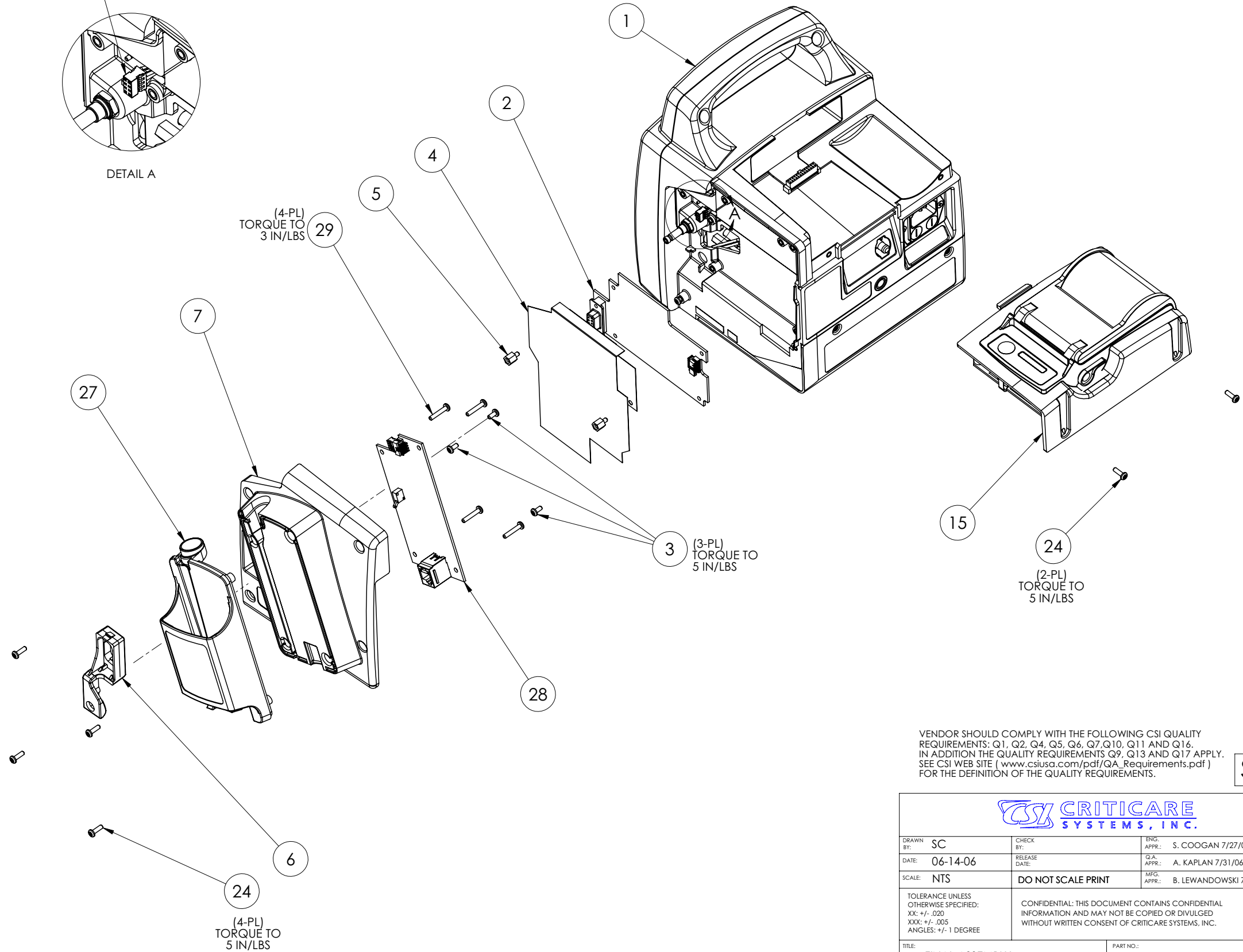

VENDOR SHOULD COMPLY WITH THE FOLLOWING CSI QUALITY REQUIREMENTS: Q1, Q2, Q4, Q5, Q6, Q7, Q10, Q11 AND Q16. IN ADDITION THE QUALITY REQUIREMENTS Q9, Q13 AND Q17 APPLY. SEE CSI WEB SITE (www.csiusa.com/pdf/QA_Requirements.pdf) FOR THE DEFINITION OF THE QUALITY REQUIREMENTS.

SW



| | | |
|--|--------------------|--|
| DRAWN BY: SC | CHECK BY: | ENG. APPR.: S. COOGAN 7/27/06 |
| DATE: 06-14-06 | RELEASE DATE: | Q.A. APPR.: A. KAPLAN 7/31/06 |
| SCALE: NTS | DO NOT SCALE PRINT | MFG. APPR.: B. LEWANDOWSKI 7/25/06 |
| TOLERANCE UNLESS OTHERWISE SPECIFIED: XX: +/- .020 XXX: +/- .005 ANGLES: +/- 1 DEGREE | | CONFIDENTIAL: THIS DOCUMENT CONTAINS CONFIDENTIAL INFORMATION AND MAY NOT BE COPIED OR DIVULGED WITHOUT WRITTEN CONSENT OF CRITICARE SYSTEMS, INC. |
| TITLE: FINAL ASSEMBLY 506DNVP3 CSI DOX, TURBO TEMP, PRNTR | | PART NO.: 93975A010 |
| DIST: 302 | | REV. 1 |
| SHEET 1 OF 2 | | |

| REVISIONS | | | |
|-----------|------|-------------|----|
| REV. | DATE | DESCRIPTION | BY |
| | | | |

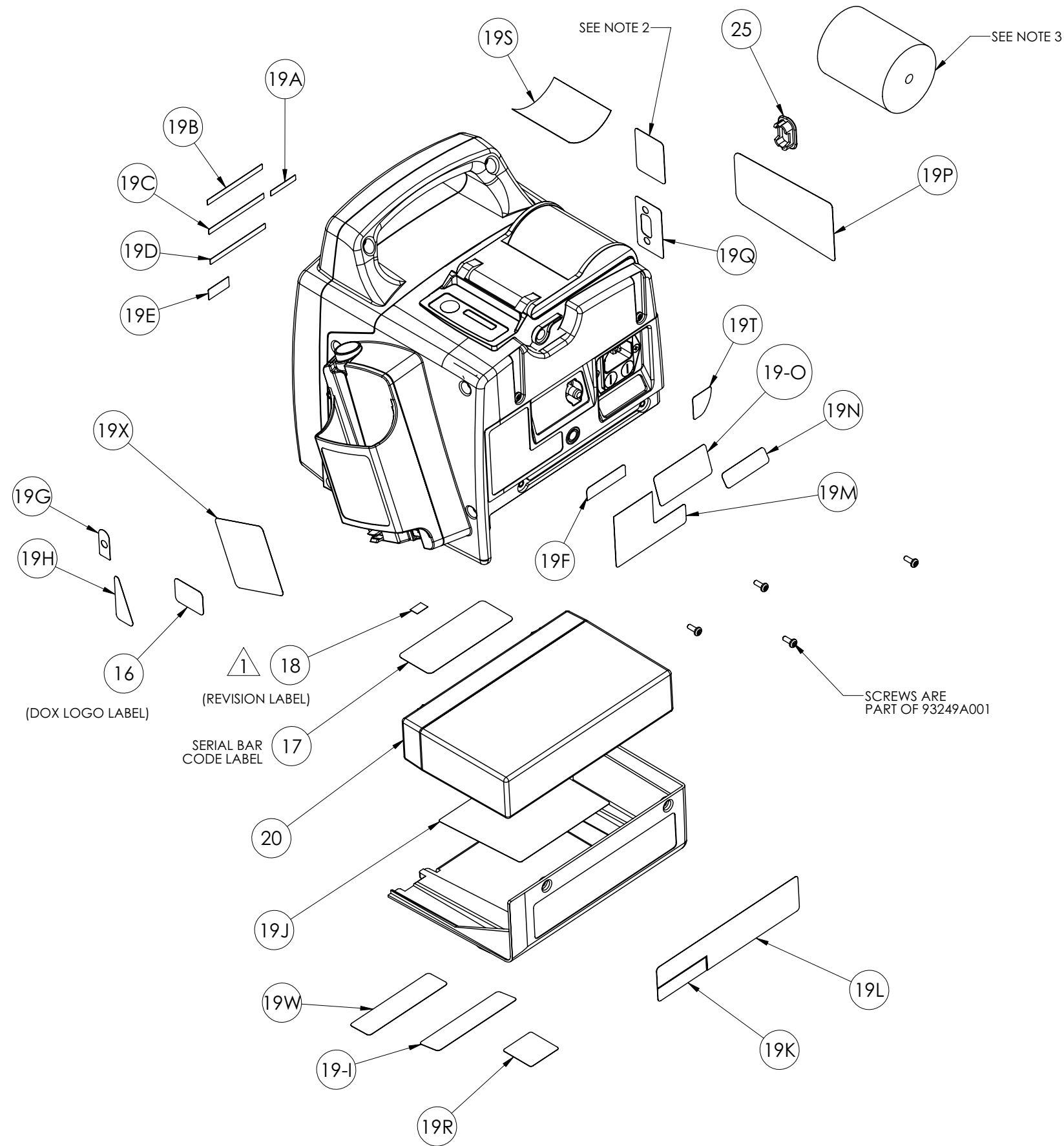

| LABELS FROM SET (ITEM 19) | |
|---------------------------|----------------------------------|
| ITEM | DESCRIPTION |
| 19-A | LABEL, LANGUAGE, MENU |
| 19-B | LABEL, LANGUAGE, TREND/PRINT |
| 19-C | LABEL, LANGUAGE, NIBP CYCLE |
| 19-D | LABEL, LANGUAGE, NIBP START/STAT |
| 19-E | LABEL, LANGUAGE, TEMP. ORAL/AX |
| 19-F | LABEL, BLANK |
| 19-G | LABEL, NIBP FITTING |
| 19-H | LABEL, SPO2 CONN. |
| 19-I | LABEL, CSI PATENT |
| 19-J | LABEL, BATTERY INSTALL |
| 19-K | LABEL, COUNTRY OF ORIGIN |
| 19-L | LABEL, CSI SUPPORT INFO |
| 19-M | LABEL, ETL SYMBOL |
| 19-N | LABEL, FUSE RATING |
| 19-O | LABEL, ELECTRICAL RATING |
| 19-P | LABEL, WARNINGS |
| 19-Q | LABEL, SERIAL PORT |
| 19-R | LABEL, WEEE DIRECTIVE |
| 19-S | LABEL, PAPER LOADING |
| 19-T | LABEL, PAPER RELEASE |
| 19-W | LABEL, ALARIS PATENT |
| 19-X | LABEL, ALARIS TURBO TEMP |

NOTE:

1. FOREIGN LANGUAGE LABELS INSTALLED AT THE CAT LEVEL. THEY ARE SHOWN ON THIS DRAWING FOR REFERENCE ONLY.
2. ADD QUALITY SEAL PN: 46036B101 (FROM CAT LEVEL BOM) TO MONITOR APPROXIMATELY ONE INCH ABOVE THE SERIAL PORT. IT SHOULD COVER THE FRONT AND REAR HOUSINGS.
3. INSTALL PRINTER PAPER PN: 40065B002 (CAT LEVEL) INTO PRINTER HOUSING.

VENDOR SHOULD COMPLY WITH THE FOLLOWING CSI QUALITY REQUIREMENTS: Q1, Q2, Q4, Q5, Q6, Q7, Q10, Q11 AND Q16. IN ADDITION THE QUALITY REQUIREMENTS Q9, Q13 AND Q17 APPLY. SEE CSI WEB SITE (www.csiusa.com/pdf/QA_Requirements.pdf) FOR THE DEFINITION OF THE QUALITY REQUIREMENTS.

SW

| DRAWN BY: SC | CHECK BY: | ENG. APPR.: |
|--|--------------------|--|
| DATE: 06-14-06 | RELEASE DATE: | Q.A. APPR.: |
| SCALE: NTS | DO NOT SCALE PRINT | MFG. APPR.: |
| TOLERANCE UNLESS OTHERWISE SPECIFIED: XX: +/- .020 XXX: +/- .005 ANGLES: +/- 1 DEGREE | | CONFIDENTIAL: THIS DOCUMENT CONTAINS CONFIDENTIAL INFORMATION AND MAY NOT BE COPIED OR DIVULGED WITHOUT WRITTEN CONSENT OF CRITICARE SYSTEMS, INC. |
| TITLE: FINAL ASSEMBLY 506DNVP3 CSI DOX, TURBO TEMP, PRNTR | | PART NO.: 93975A010 |
| DIST: 302 | | REV. 1 |
| SHEET 2 OF 2 | | |

| REVISIONS | | | |
|-----------|---------|---------------|-----|
| REV. | DATE | DESCRIPTION | BY |
| 1 | 12/8/06 | SEE ECN #8922 | DBL |

TEMPERATURE CONNECTOR

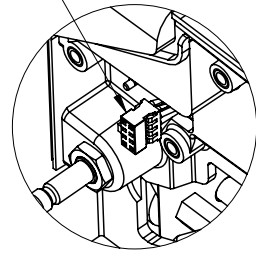

DETAIL A

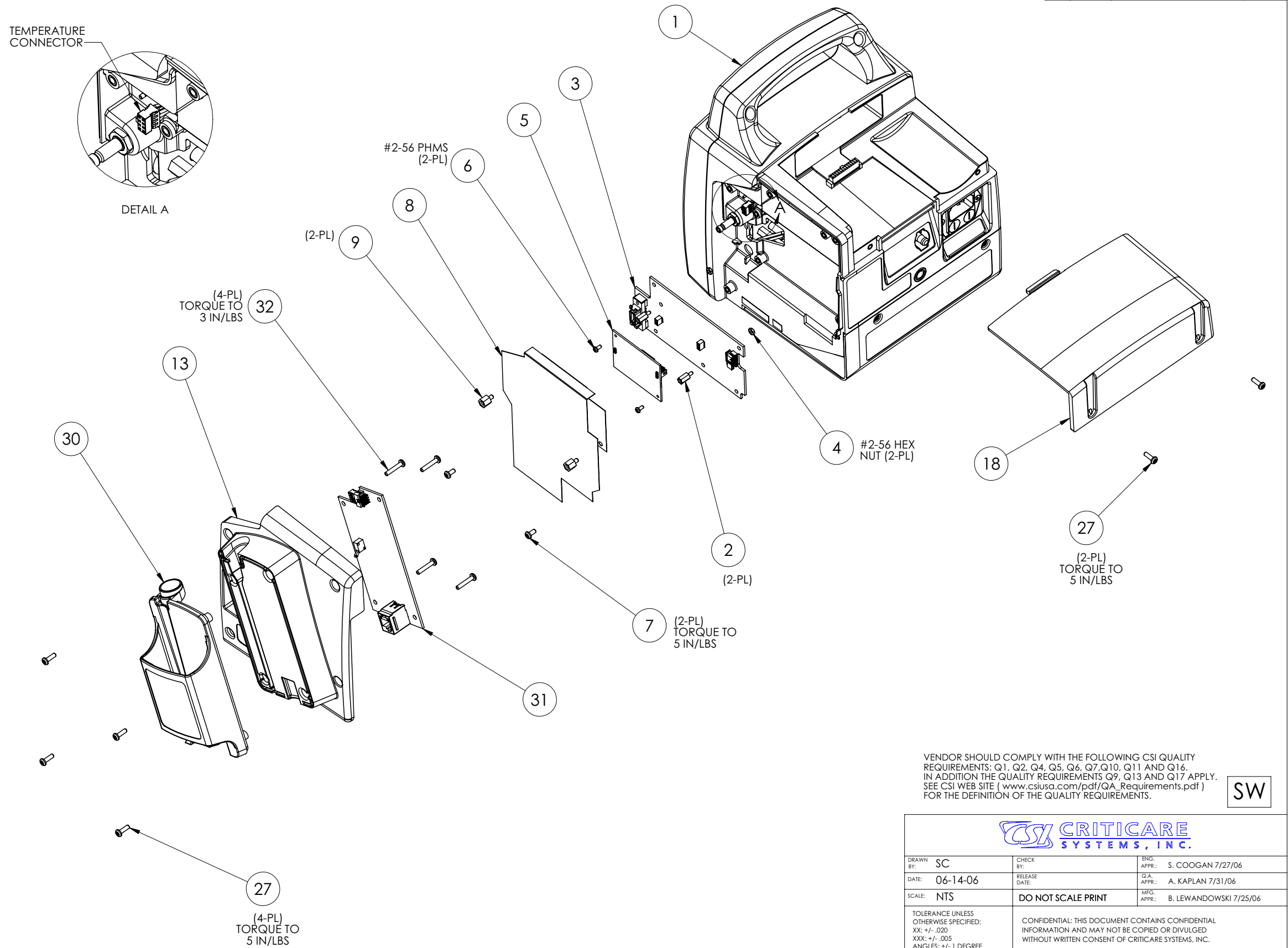

VENDOR SHOULD COMPLY WITH THE FOLLOWING CSI QUALITY REQUIREMENTS: Q1, Q2, Q4, Q5, Q6, Q7, Q10, Q11 AND Q16. IN ADDITION THE QUALITY REQUIREMENTS Q9, Q13 AND Q17 APPLY. SEE CSI WEB SITE (www.csiusa.com/pdf/QA_Requirements.pdf) FOR THE DEFINITION OF THE QUALITY REQUIREMENTS.

SW



| | | |
|--|--------------------|--|
| DRAWN BY: SC | CHECK BY: | ENG. APPR.: S. COOGAN 7/27/06 |
| DATE: 06-14-06 | RELEASE DATE: | Q.A. APPR.: A. KAPLAN 7/31/06 |
| SCALE: NTS | DO NOT SCALE PRINT | MFG. APPR.: B. LEWANDOWSKI 7/25/06 |
| TOLERANCE UNLESS OTHERWISE SPECIFIED: XX: +/- .020 XXX: +/- .005 ANGLES: +/- 1 DEGREE | | CONFIDENTIAL: THIS DOCUMENT CONTAINS CONFIDENTIAL INFORMATION AND MAY NOT BE COPIED OR DIVULGED WITHOUT WRITTEN CONSENT OF CRITICARE SYSTEMS, INC. |
| TITLE: FINAL ASSEMBLY 506LNV3 NELLCOR SPO2, TURBO TEMP | | PART NO.: 93975A011 |
| DIST: 302 | | REV. 1 |
| SHEET 1 OF 2 | | |

| REVISIONS | | | |
|-----------|------|-------------|----|
| REV. | DATE | DESCRIPTION | BY |
| | | | |

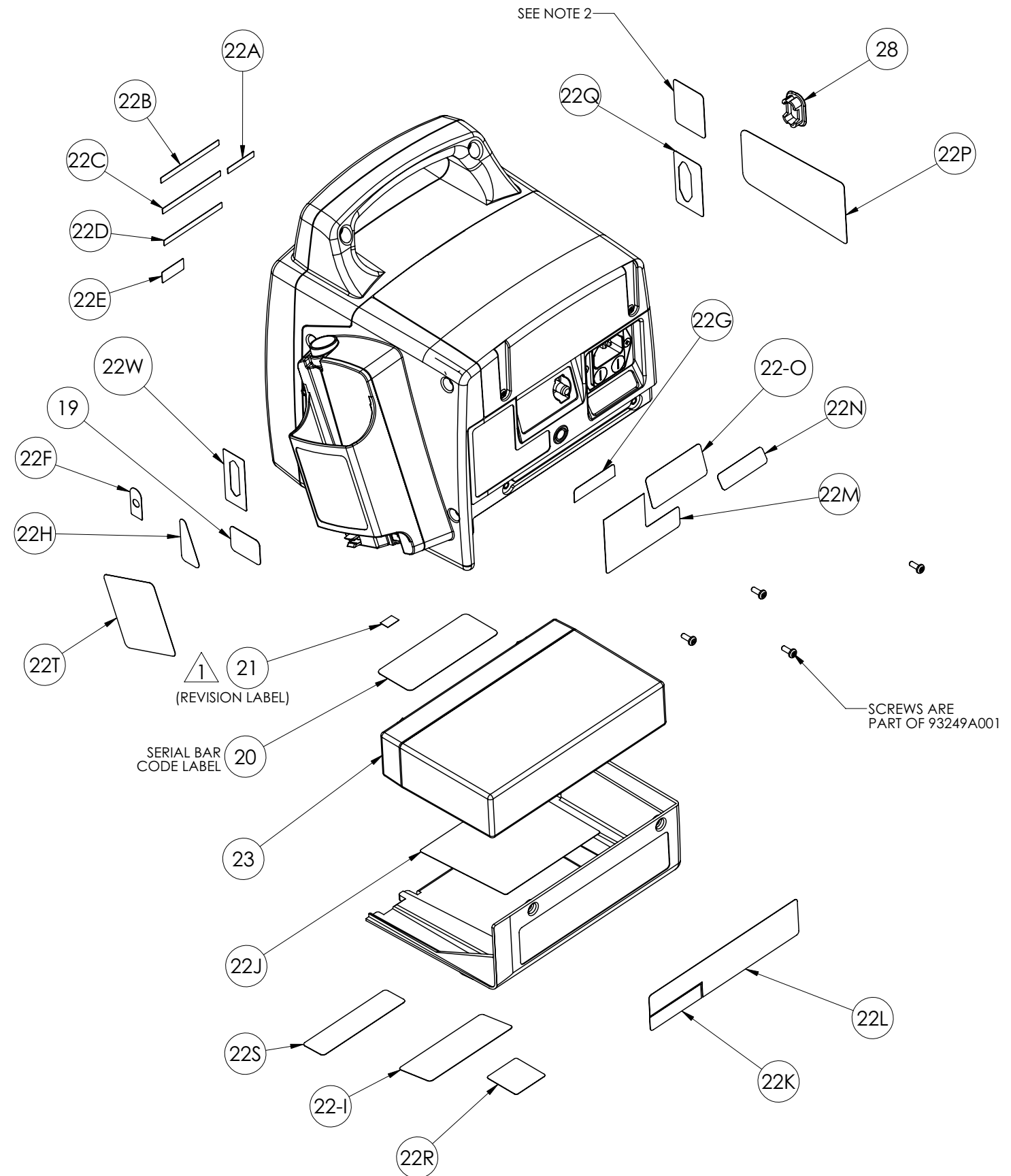

| LABELS FROM SET (ITEM 22) | |
|---------------------------|----------------------------------|
| ITEM | DESCRIPTION |
| 22-A | LABEL, LANGUAGE, MENU |
| 22-B | LABEL, LANGUAGE, TREND/PRINT |
| 22-C | LABEL, LANGUAGE, NIBP CYCLE |
| 22-D | LABEL, LANGUAGE, NIBP START/STAT |
| 22-E | LABEL, LANGUAGE, TEMP. ORAL/AX |
| 22-F | LABEL, NIBP FITTING |
| 22-G | LABEL, BLANK |
| 22-H | LABEL, SPO2 CONN. |
| 22-I | LABEL, CSI PATENT |
| 22-J | LABEL, BATTERY INSTALL |
| 22-K | LABEL, COUNTRY OF ORIGIN |
| 22-L | LABEL, CSISUPPORT INFO |
| 22-M | LABEL, ETL SYMBOL |
| 22-N | LABEL, FUSE RATING |
| 22-O | LABEL, ELECTRICAL RATING |
| 22-P | LABEL, WARNINGS |
| 22-Q | LABEL, SERIAL PORT |
| 22-R | LABEL, WEEE DIRECTIVE |
| 22-S | LABEL, ALARIS PATENT |
| 22-T | LABEL, ALARIS TURBO TEMP |
| 22-W | LABEL, SPO2 CONN (NELLCOR) |

NOTE:

1. FOREIGN LANGUAGE LABELS INSTALLED AT THE CAT LEVEL. THEY ARE SHOWN ON THIS DRAWING FOR REFERENCE ONLY.
2. ADD QUALITY SEAL PN: 46036B101 (FROM CAT LEVEL BOM) TO MONITOR APPROXIMATELY ONE INCH ABOVE THE SERIAL PORT. IT SHOULD COVER THE FRONT AND REAR HOUSINGS.

VENDOR SHOULD COMPLY WITH THE FOLLOWING CSI QUALITY REQUIREMENTS: Q1, Q2, Q4, Q5, Q6, Q7, Q10, Q11 AND Q16. IN ADDITION THE QUALITY REQUIREMENTS Q9, Q13 AND Q17 APPLY. SEE CSI WEB SITE (www.csiusa.com/pdf/QA_Requirements.pdf) FOR THE DEFINITION OF THE QUALITY REQUIREMENTS.

SW

| DRAWN BY: SC | CHECK BY: | ENG. APPR.: |
|--|------------------------|--|
| DATE: 06-14-06 | RELEASE DATE: | Q.A. APPR.: |
| SCALE: NTS | DO NOT SCALE PRINT | MFG. APPR.: |
| TOLERANCE UNLESS OTHERWISE SPECIFIED: XX: +/- .020 XXX: +/- .005 ANGLES: +/- 1 DEGREE | | CONFIDENTIAL: THIS DOCUMENT CONTAINS CONFIDENTIAL INFORMATION AND MAY NOT BE COPIED OR DIVULGED WITHOUT WRITTEN CONSENT OF CRITICARE SYSTEMS, INC. |
| TITLE: FINAL ASSEMBLY 506LNV3 NELLCOR SPO2, TURBO TEMP | PART NO.: 93975A011 | REV.: 1 |
| DST: 302 | | SHEET 2 OF 2 |

| REVISIONS | | | |
|-----------|---------|---------------|-----|
| REV. | DATE | DESCRIPTION | BY |
| 1 | 12/8/06 | SEE ECN #8922 | DBL |

TEMPERATURE CONNECTOR

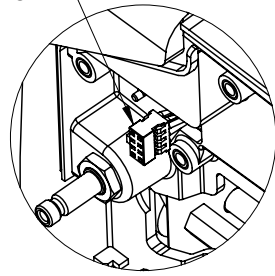

DETAIL A

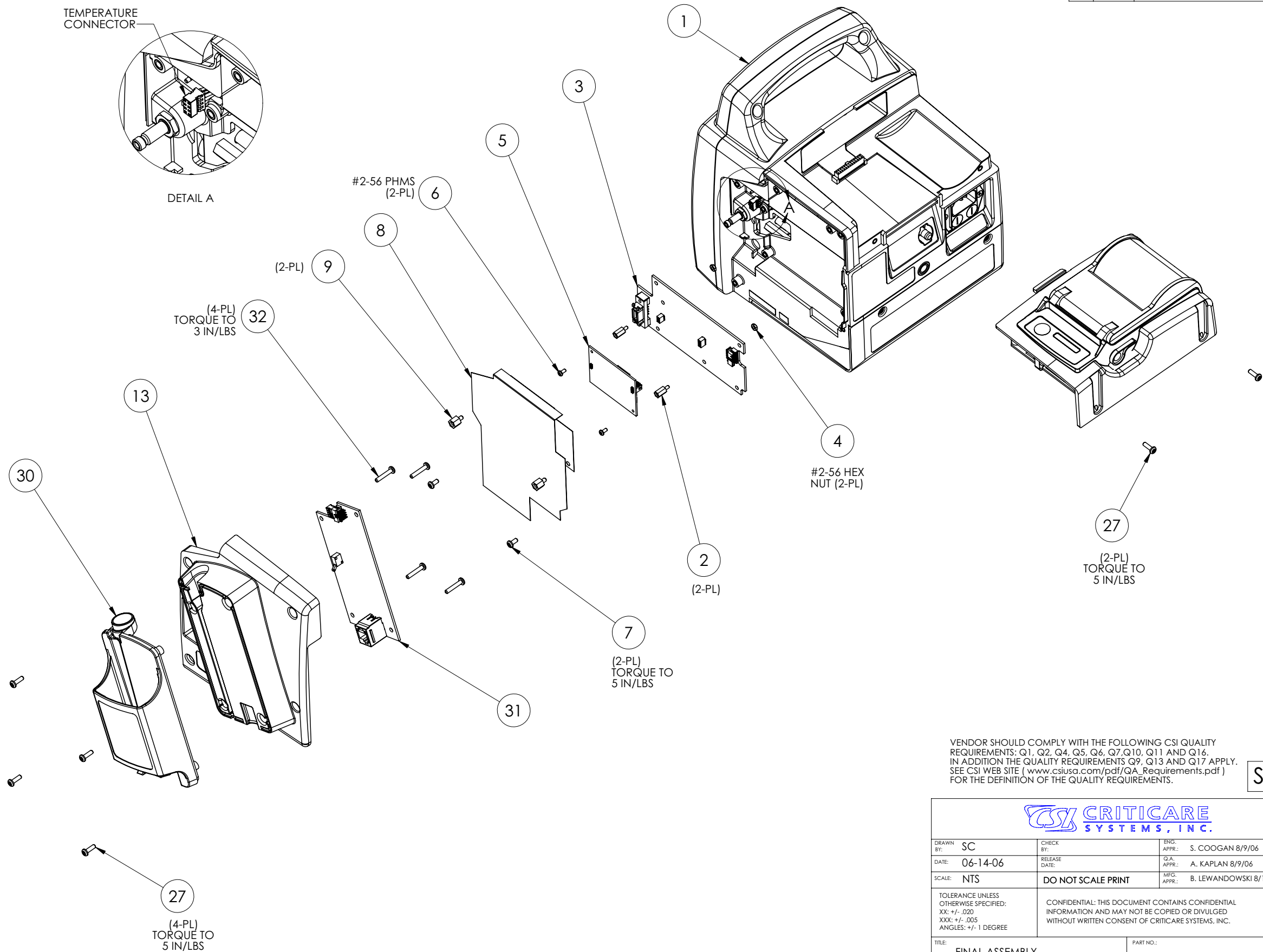

VENDOR SHOULD COMPLY WITH THE FOLLOWING CSI QUALITY REQUIREMENTS: Q1, Q2, Q4, Q5, Q6, Q7, Q10, Q11 AND Q16. IN ADDITION THE QUALITY REQUIREMENTS Q9, Q13 AND Q17 APPLY. SEE CSI WEB SITE (www.csiusa.com/pdf/QA_Requirements.pdf) FOR THE DEFINITION OF THE QUALITY REQUIREMENTS.

SW



| | | |
|--|--------------------|--|
| DRAWN BY: SC | CHECK BY: | ENG. APPR.: S. COOGAN 8/9/06 |
| DATE: 06-14-06 | RELEASE DATE: | Q.A. APPR.: A. KAPLAN 8/9/06 |
| SCALE: NTS | DO NOT SCALE PRINT | MFG. APPR.: B. LEWANDOWSKI 8/10/06 |
| TOLERANCE UNLESS OTHERWISE SPECIFIED: XX: +/- .020 XXX: +/- .005 ANGLES: +/- 1 DEGREE | | CONFIDENTIAL: THIS DOCUMENT CONTAINS CONFIDENTIAL INFORMATION AND MAY NOT BE COPIED OR DIVULGED WITHOUT WRITTEN CONSENT OF CRITICARE SYSTEMS, INC. |
| TITLE: FINAL ASSEMBLY 506LNP3 NELLCOR, TURBO TEMP, PRNTR | | PART NO.: 93975A012 |
| | | REV. 1 |
| DST: 302 | | SHEET 1 OF 2 |

| REVISIONS | | | |
|-----------|------|-------------|----|
| REV. | DATE | DESCRIPTION | BY |
| | | | |

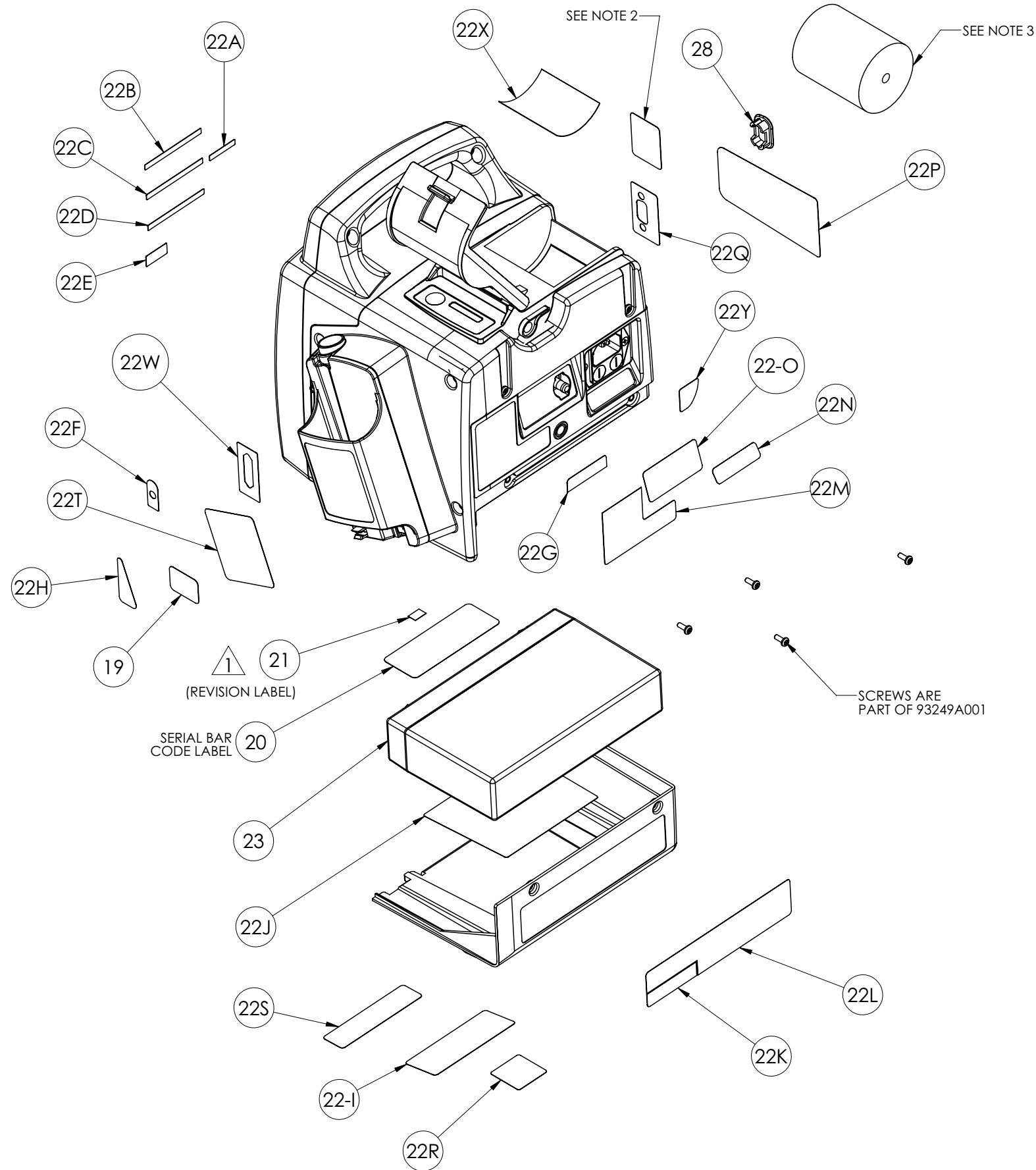

| LABELS FROM SET (ITEM 22) | |
|---------------------------|----------------------------------|
| ITEM | DESCRIPTION |
| 22-A | LABEL, LANGUAGE, MENU |
| 22-B | LABEL, LANGUAGE, TREND/PRINT |
| 22-C | LABEL, LANGUAGE, NIBP CYCLE |
| 22-D | LABEL, LANGUAGE, NIBP START/STAT |
| 22-E | LABEL, LANGUAGE, TEMP. ORAL/AX |
| 22-F | LABEL, NIBP FITTING |
| 22-G | LABEL, BLANK |
| 22-H | LABEL, SPO2 CONN. |
| 22-I | LABEL, CSI PATENT |
| 22-J | LABEL, BATTERY INSTALL |
| 22-K | LABEL, COUNTRY OF ORIGIN |
| 22-L | LABEL, CSI SUPPORT INFO |
| 22-M | LABEL, ETL SYMBOL |
| 22-N | LABEL, FUSE RATING |
| 22-O | LABEL, ELECTRICAL RATING |
| 22-P | LABEL, WARNINGS |
| 22-Q | LABEL, SERIAL PORT |
| 22-R | LABEL, WEEE DIRECTIVE |
| 22-S | LABEL, ALARIS PATENT |
| 22-T | LABEL, ALARIS TURBO TEMP |
| 22-W | LABEL, SPO2 CONN (NELLCOR) |
| 22-X | LABEL, PAPER LOADING |
| 22-Y | LABEL, PAPER RELEASE |

NOTE:

1. FOREIGN LANGUAGE LABELS INSTALLED AT THE CAT LEVEL. THEY ARE SHOWN ON THIS DRAWING FOR REFERENCE ONLY.
2. ADD QUALITY SEAL PN: 46036B101 (FROM CAT LEVEL BOM) TO MONITOR APPROXIMATELY ONE INCH ABOVE THE SERIAL PORT. IT SHOULD COVER THE FRONT AND REAR HOUSINGS.
3. INSTALL PRINTER PAPER PN: 40065B002 (CAT LEVEL) INTO PRINTER HOUSING.

VENDOR SHOULD COMPLY WITH THE FOLLOWING CSI QUALITY REQUIREMENTS: Q1, Q2, Q4, Q5, Q6, Q7, Q10, Q11 AND Q16. IN ADDITION THE QUALITY REQUIREMENTS Q9, Q13 AND Q17 APPLY. SEE CSI WEB SITE (www.csiusa.com/pdf/QA_Requirements.pdf) FOR THE DEFINITION OF THE QUALITY REQUIREMENTS.

SW

| | | |
|--|------------------------|--|
| | | |
| DRAWN BY: SC | CHECK BY: | ENG. APPR.: |
| DATE: 06-14-06 | RELEASE DATE: | Q.A. APPR.: |
| SCALE: NTS | DO NOT SCALE PRINT | MFG. APPR.: |
| TOLERANCE UNLESS OTHERWISE SPECIFIED: XX: +/- .020 XXX: +/- .005 ANGLES: +/- 1 DEGREE | | CONFIDENTIAL: THIS DOCUMENT CONTAINS CONFIDENTIAL INFORMATION AND MAY NOT BE COPIED OR DIVULGED WITHOUT WRITTEN CONSENT OF CRITICARE SYSTEMS, INC. |
| TITLE: FINAL ASSEMBLY 506LNVP3 NELLCOR, TURBO TEMP, PRNTR | PART NO.: 93975A012 | REV.: 1 |
| DIST: 302 | | SHEET 2 OF 2 |

| REVISIONS | | | |
|-----------|---------|---------------|-----|
| REV. | DATE | DESCRIPTION | BY |
| 1 | 12/8/06 | SEE ECN #8922 | DBL |

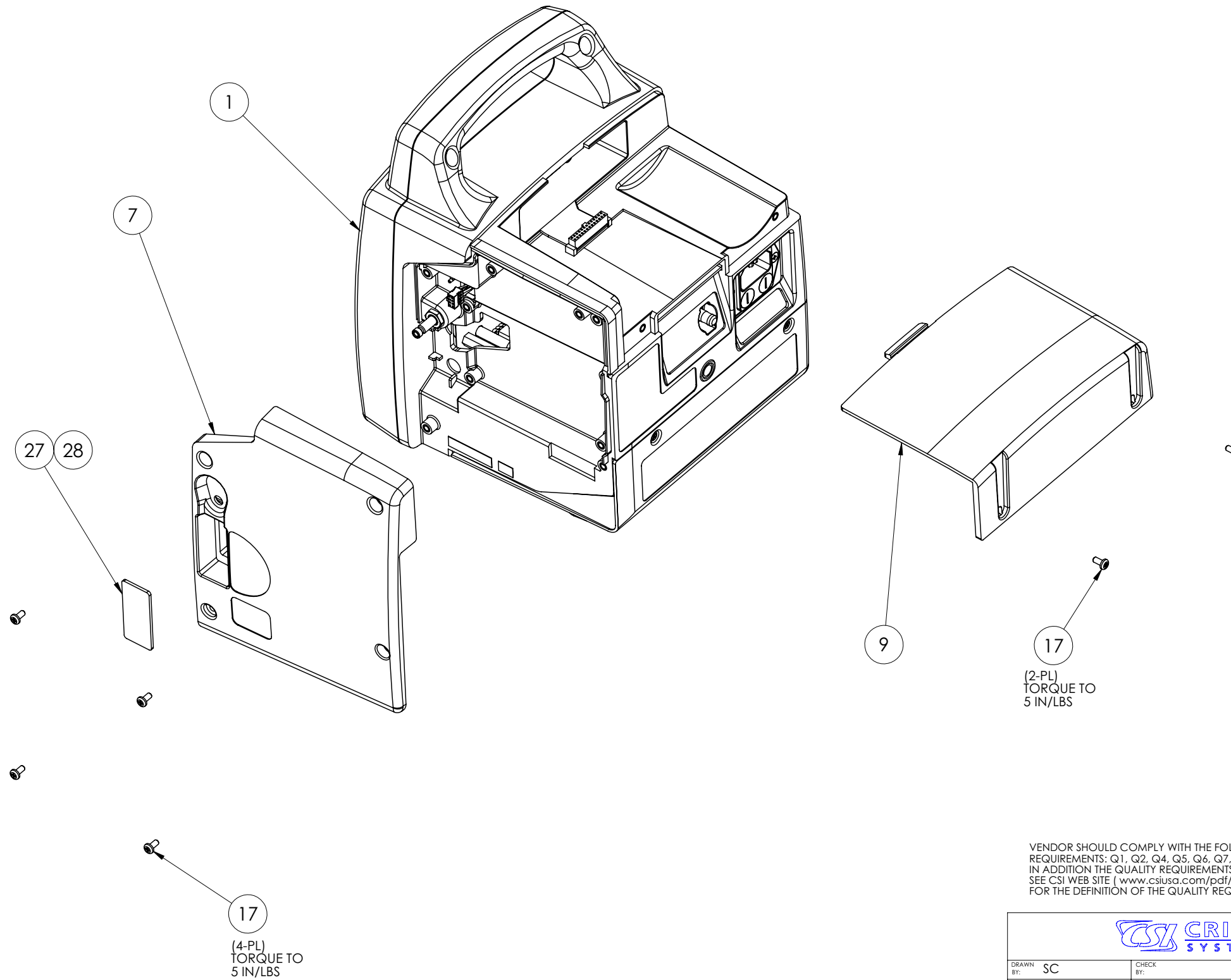

NOTES:

1. CSI RESERVES THE RIGHT TO INSPECT THIS ITEM AT THE VENDORS FACILITY. VENDOR'S INSPECTION SYSTEM AND MANUFACTURING PROCESS ARE SUBJECT TO REVIEW/APPROVAL, VERIFICATION AND ANALYSIS BY AUTHORIZED CSI REPRESENTATIVES. ALL CHANGES IN DESIGN, COMPONENTS, PROCESSES OR FABRICATION MUST BE AUTHORIZED IN WRITING BY CSI PRIOR TO IMPLEMENTATION. ALL DEVIATIONS FROM DRAWINGS, SPECIFICATIONS, OR OTHER REQUIREMENTS MUST BE REPORTED TO CSI FOR APPROVAL PRIOR TO SHIPMENT.

VENDOR SHOULD COMPLY WITH THE FOLLOWING CSI QUALITY REQUIREMENTS: Q1, Q2, Q4, Q5, Q6, Q7, Q10, Q11 AND Q16. IN ADDITION THE QUALITY REQUIREMENTS Q9, Q13 AND Q17 APPLY. SEE CSI WEB SITE (www.csiusa.com/pdf/QA_Requirements.pdf) FOR THE DEFINITION OF THE QUALITY REQUIREMENTS.

SW



| | | |
|--|--------------------|--|
| DRAWN BY: SC | CHECK BY: | ENG. APPR.: S. COOGAN 6/12/06 |
| DATE: 06-06-06 | RELEASE DATE: | Q.A. APPR.: A. KAPLAN 6/12/06 |
| SCALE: NTS | DO NOT SCALE PRINT | MFG. APPR.: B. LEWANDOWSKI 6/13/06 |
| TOLERANCE UNLESS OTHERWISE SPECIFIED: XX: +/- .020 XXX: +/- .005 ANGLES: +/- 1 DEGREE | | CONFIDENTIAL: THIS DOCUMENT CONTAINS CONFIDENTIAL INFORMATION AND MAY NOT BE COPIED OR DIVULGED WITHOUT WRITTEN CONSENT OF CRITICARE SYSTEMS, INC. |
| TITLE: FINAL ASSEMBLY 506N3 | | PART NO.: 93975A020 |
| DIST: 301 | | REV. 1 |
| SHEET 1 OF 2 | | |

| REVISIONS | | | |
|-----------|------|-------------|----|
| REV. | DATE | DESCRIPTION | BY |
| | | | |

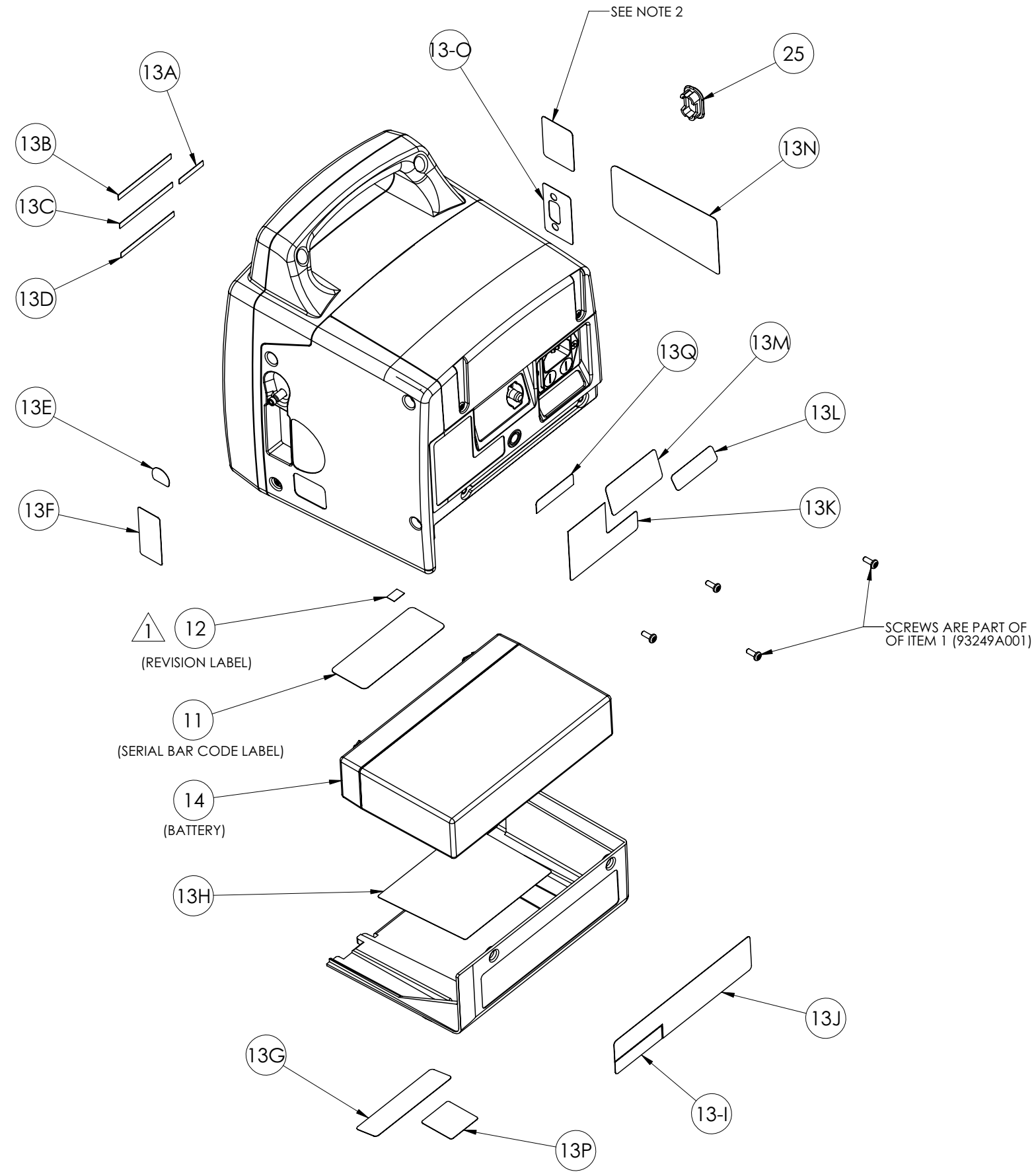

LABELS FROM SET (ITEM 13)

| ITEM | DESCRIPTION |
|------|----------------------------------|
| 13-A | LABEL, LANGUAGE, MENU |
| 13-B | LABEL, LANGUAGE, TREND/PRINT |
| 13-C | LABEL, LANGUAGE, NIBP CYCLE |
| 13-D | LABEL, LANGUAGE, NIBP START/STAT |
| 13-E | LABEL, NIBP FITTING (NON-TEMP) |
| 13-F | LABEL, BLANK (NO SPO2) |
| 13-G | LABEL, CSI PATENT |
| 13-H | LABEL, BATTERY INSTALL |
| 13-I | LABEL, COUNTRY OF ORIGIN |
| 13-J | LABEL, CSI SUPPORT INFO |
| 13-K | LABEL, ETL SYMBOL |
| 13-L | LABEL, FUSE RATING |
| 13-M | LABEL, ELECTRICAL RATING |
| 13-N | LABEL, WARNINGS |
| 13-O | LABEL, SERIAL PORT |
| 13-P | LABEL, WEEE DIRECTIVE |
| 13-Q | LABEL, CE MARK |

- NOTE:
1. FOREIGN LANGUAGE LABELS INSTALLED AT THE CAT LEVEL. THEY ARE SHOWN ON THIS DRAWING FOR REFERENCE ONLY.
 2. ADD QUALITY SEAL PN: 46036B101 (FROM CAT LEVEL BOM) TO MONITOR APPROXIMATELY ONE INCH ABOVE THE SERIAL PORT. IT SHOULD COVER THE FRONT AND REAR HOUSINGS.

VENDOR SHOULD COMPLY WITH THE FOLLOWING CSI QUALITY REQUIREMENTS: Q1, Q2, Q4, Q5, Q6, Q7, Q10, Q11 AND Q16. IN ADDITION THE QUALITY REQUIREMENTS Q9, Q13 AND Q17 APPLY. SEE CSI WEB SITE (www.csiusa.com/pdf/QA_Requirements.pdf) FOR THE DEFINITION OF THE QUALITY REQUIREMENTS.

SW

| | | |
|--|--|-------------|
| CSI CRITICARE SYSTEMS, INC. | | |
| DRAWN BY: SC | CHECK BY: | ENG. APPR.: |
| DATE: 06-06-06 | RELEASE DATE: | Q.A. APPR.: |
| SCALE: NTS | DO NOT SCALE PRINT | |
| TOLERANCE UNLESS OTHERWISE SPECIFIED: XX: +/- .020 XXX: +/- .005 ANGLES: +/- 1 DEGREE | CONFIDENTIAL: THIS DOCUMENT CONTAINS CONFIDENTIAL INFORMATION AND MAY NOT BE COPIED OR DIVULGED WITHOUT WRITTEN CONSENT OF CRITICARE SYSTEMS, INC. | |
| TITLE: FINAL ASSEMBLY 506N3 | PART NO.: 93975A020 | REV. 1 |
| DIST: 301 | SHEET 2 OF 2 | |

| REVISIONS | | | |
|-----------|---------|---------------|-----|
| REV. | DATE | DESCRIPTION | BY |
| 1 | 12/8/06 | SEE ECN #8922 | DBL |

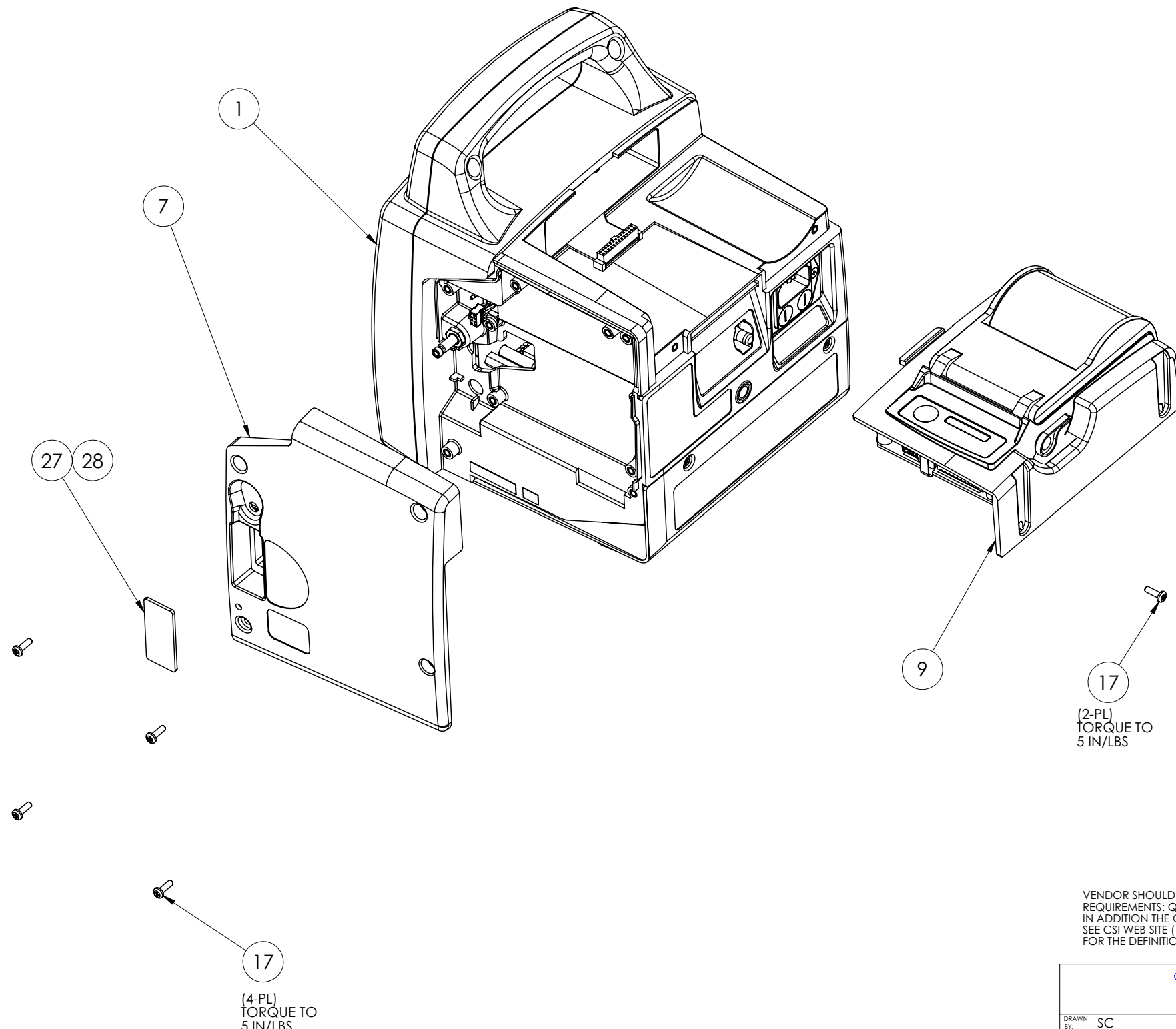

VENDOR SHOULD COMPLY WITH THE FOLLOWING CSI QUALITY REQUIREMENTS: Q1, Q2, Q4, Q5, Q6, Q7, Q10, Q11 AND Q16. IN ADDITION THE QUALITY REQUIREMENTS Q9, Q13 AND Q17 APPLY. SEE CSI WEB SITE (www.csiusa.com/pdf/QA_Requirements.pdf) FOR THE DEFINITION OF THE QUALITY REQUIREMENTS.

SW



| | | |
|----------------|--------------------|------------------------------------|
| DRAWN BY: SC | CHECK BY: | ENG. APPR.: S. COOGAN 6/12/06 |
| DATE: 06-06-06 | RELEASE DATE: | Q.A. APPR.: A. KAPLAN 6/12/06 |
| SCALE: NTS | DO NOT SCALE PRINT | MFG. APPR.: B. LEWANDOWSKI 6/13/06 |

TOLERANCE UNLESS OTHERWISE SPECIFIED:
 XX: +/- .020
 XXX: +/- .005
 ANGLES: +/- 1 DEGREE

CONFIDENTIAL: THIS DOCUMENT CONTAINS CONFIDENTIAL INFORMATION AND MAY NOT BE COPIED OR DIVULGED WITHOUT WRITTEN CONSENT OF CRITICARE SYSTEMS, INC.

| | | |
|------------------------------|---------------------|--------|
| TITLE: FINAL ASSEMBLY 506NP3 | PART NO.: 93975A021 | REV. 1 |
| DIST: 301 | SHEET 1 OF 2 | |

NOTES:
 1. CSI RESERVES THE RIGHT TO INSPECT THIS ITEM AT THE VENDORS FACILITY. VENDOR'S INSPECTION SYSTEM AND MANUFACTURING PROCESS ARE SUBJECT TO REVIEW/APPROVAL, VERIFICATION AND ANALYSIS BY AUTHORIZED CSI REPRESENTATIVES. ALL CHANGES IN DESIGN, COMPONENTS, PROCESSES OR FABRICATION MUST BE AUTHORIZED IN WRITING BY CSI PRIOR TO IMPLEMENTATION. ALL DEVIATIONS FROM DRAWINGS, SPECIFICATIONS, OR OTHER REQUIREMENTS MUST BE REPORTED TO CSI FOR APPROVAL PRIOR TO SHIPMENT.

| REVISIONS | | | |
|-----------|------|-------------|----|
| REV. | DATE | DESCRIPTION | BY |
| | | | |

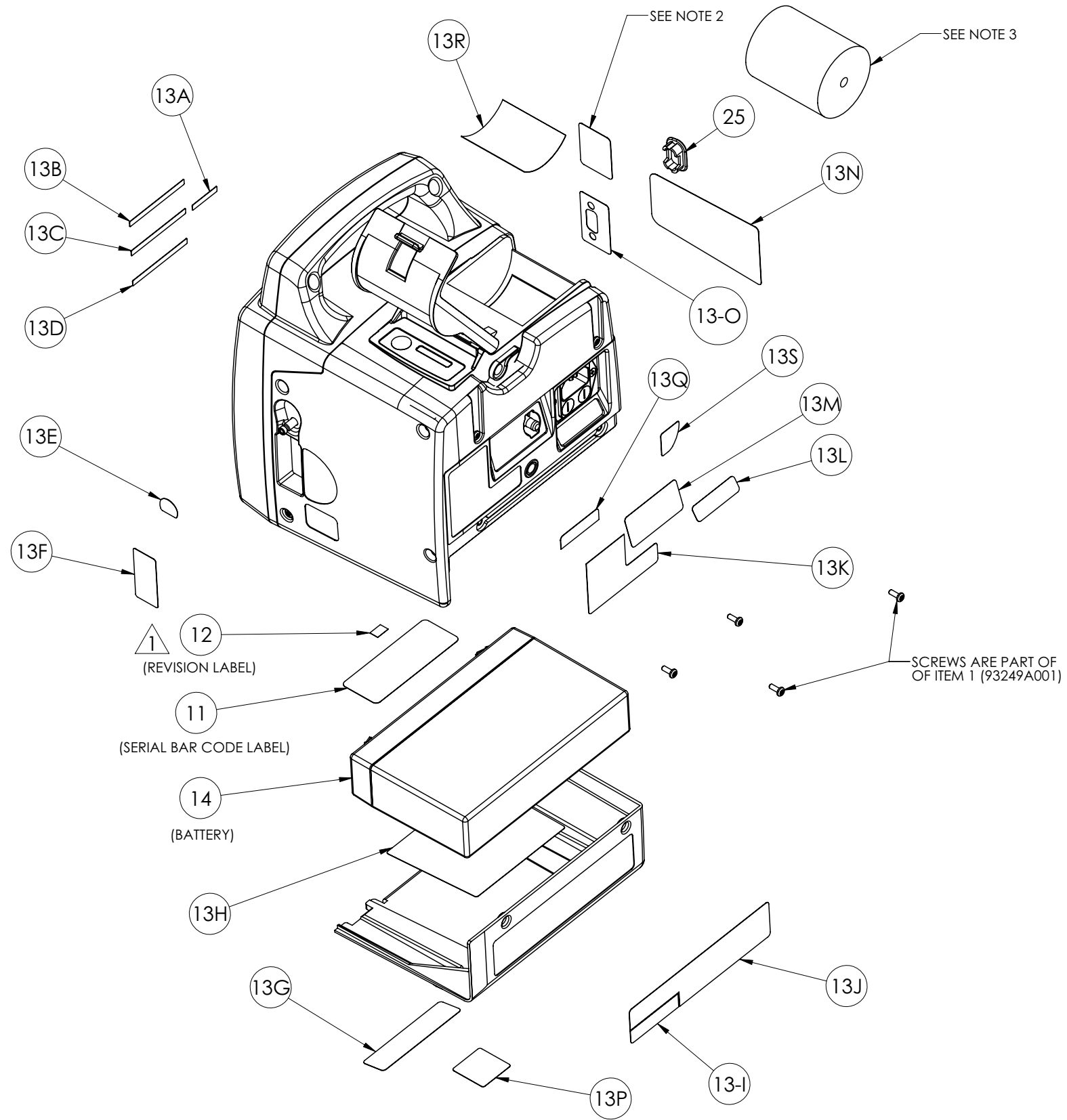

LABELS FROM SET (ITEM 13)

| ITEM | DESCRIPTION |
|------|----------------------------------|
| 13-A | LABEL, LANGUAGE, MENU |
| 13-B | LABEL, LANGUAGE, TREND/PRINT |
| 13-C | LABEL, LANGUAGE, NIBP CYCLE |
| 13-D | LABEL, LANGUAGE, NIBP START/STAT |
| 13-E | LABEL, NIBP FITTING (NON-TEMP) |
| 13-F | LABEL, BLANK (NO SPO2) |
| 13-G | LABEL, CSI PATENT |
| 13-H | LABEL, BATTERY INSTALL |
| 13-I | LABEL, COUNTRY OF ORIGIN |
| 13-J | LABEL, CSI SUPPORT INFO |
| 13-K | LABEL, ETL SYMBOL |
| 13-L | LABEL, FUSE RATING |
| 13-M | LABEL, ELECTRICAL RATING |
| 13-N | LABEL, WARNINGS |
| 13-O | LABEL, SERIAL PORT |
| 13-P | LABEL, WEEE DIRECTIVE |
| 13-Q | LABEL, CE MARK |
| 13-R | LABEL, PAPER LOADING |
| 13-S | LABEL, PAPER RELEASE |

NOTE:

1. FOREIGN LANGUAGE LABELS INSTALLED AT THE CAT LEVEL. THEY ARE SHOWN ON THIS DRAWING FOR REFERENCE ONLY.
2. ADD QUALITY SEAL PN: 46036B101 (FROM CAT LEVEL BOM) TO MONITOR APPROXIMATELY ONE INCH ABOVE THE SERIAL PORT. IT SHOULD COVER THE FRONT AND REAR HOUSINGS.
3. INSTALL PRINTER PAPER PN: 40065B002 (CAT LEVEL) INTO PRINTER HOUSING.

VENDOR SHOULD COMPLY WITH THE FOLLOWING CSI QUALITY REQUIREMENTS: Q1, Q2, Q4, Q5, Q6, Q7, Q10, Q11 AND Q16. IN ADDITION THE QUALITY REQUIREMENTS Q9, Q13 AND Q17 APPLY. SEE CSI WEB SITE (www.csiusa.com/pdf/QA_Requirements.pdf) FOR THE DEFINITION OF THE QUALITY REQUIREMENTS.

SW

| DRAWN BY: SC | CHECK BY: | ENG. APPR.: |
|--|--------------------|--|
| DATE: 06-06-06 | RELEASE DATE: | Q.A. APPR.: |
| SCALE: NTS | DO NOT SCALE PRINT | MFG. APPR.: |
| TOLERANCE UNLESS OTHERWISE SPECIFIED: XX: +/- .020 XXX: +/- .005 ANGLES: +/- 1 DEGREE | | CONFIDENTIAL: THIS DOCUMENT CONTAINS CONFIDENTIAL INFORMATION AND MAY NOT BE COPIED OR DIVULGED WITHOUT WRITTEN CONSENT OF CRITICARE SYSTEMS, INC. |
| TITLE: FINAL ASSEMBLY 506NP3 | | PART NO.: 93975A021 REV.: 1 |
| DIST: 301 | | SHEET 2 OF 2 |

| REVISIONS | | | |
|-----------|---------|---------------|-----|
| REV. | DATE | DESCRIPTION | BY |
| 1 | 12/8/06 | SEE ECN #8922 | DBL |

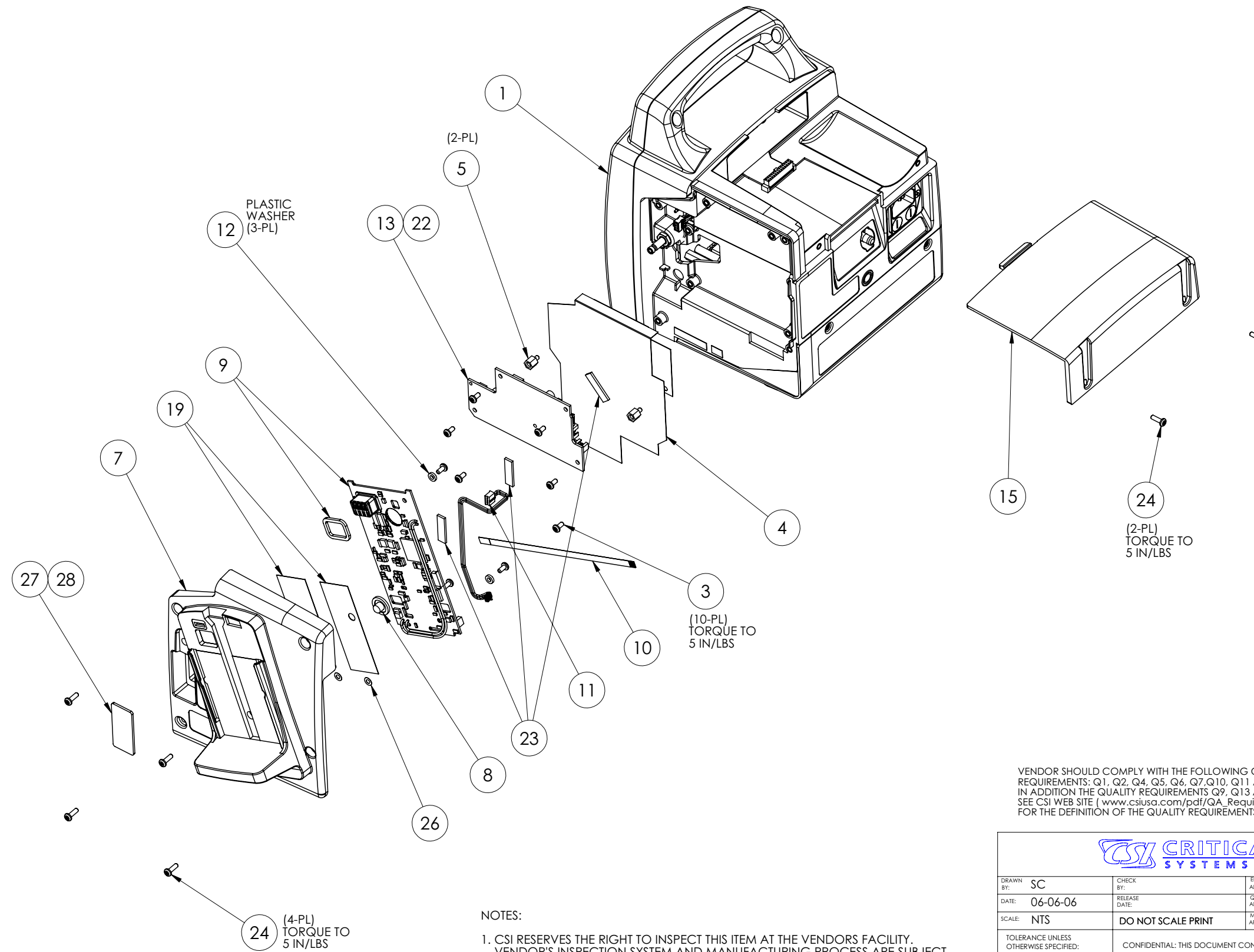

NOTES:

1. CSI RESERVES THE RIGHT TO INSPECT THIS ITEM AT THE VENDORS FACILITY. VENDOR'S INSPECTION SYSTEM AND MANUFACTURING PROCESS ARE SUBJECT TO REVIEW/APPROVAL, VERIFICATION AND ANALYSIS BY AUTHORIZED CSI REPRESENTATIVES. ALL CHANGES IN DESIGN, COMPONENTS, PROCESSES OR FABRICATION MUST BE AUTHORIZED IN WRITING BY CSI PRIOR TO IMPLEMENTATION. ALL DEVIATIONS FROM DRAWINGS, SPECIFICATIONS, OR OTHER REQUIREMENTS MUST BE REPORTED TO CSI FOR APPROVAL PRIOR TO SHIPMENT.

VENDOR SHOULD COMPLY WITH THE FOLLOWING CSI QUALITY REQUIREMENTS: Q1, Q2, Q4, Q5, Q6, Q7, Q10, Q11 AND Q16. IN ADDITION THE QUALITY REQUIREMENTS Q9, Q13 AND Q17 APPLY. SEE CSI WEB SITE (www.csiusa.com/pdf/QA_Requirements.pdf) FOR THE DEFINITION OF THE QUALITY REQUIREMENTS.

SW

| | | |
|--|--|------------------------------------|
| | | |
| DRAWN BY: SC | CHECK BY: | ENG. APPR.: S. COOGAN 6/12/06 |
| DATE: 06-06-06 | RELEASE DATE: | Q.A. APPR.: A. KAPLAN 6/12/06 |
| SCALE: NTS | DO NOT SCALE PRINT | MFG. APPR.: B. LEWANDOWSKI 6/13/06 |
| TOLERANCE UNLESS OTHERWISE SPECIFIED: XX: +/- .020 XXX: +/- .005 ANGLES: +/- 1 DEGREE | CONFIDENTIAL: THIS DOCUMENT CONTAINS CONFIDENTIAL INFORMATION AND MAY NOT BE COPIED OR DIVULGED WITHOUT WRITTEN CONSENT OF CRITICARE SYSTEMS, INC. | |
| TITLE: FINAL ASSEMBLY 506NT3 | PART NO.: 93975A022 | REV. 1 |
| DIST: 301 | SHEET 1 OF 2 | |

| REVISIONS | | | |
|-----------|------|-------------|----|
| REV. | DATE | DESCRIPTION | BY |
| | | | |

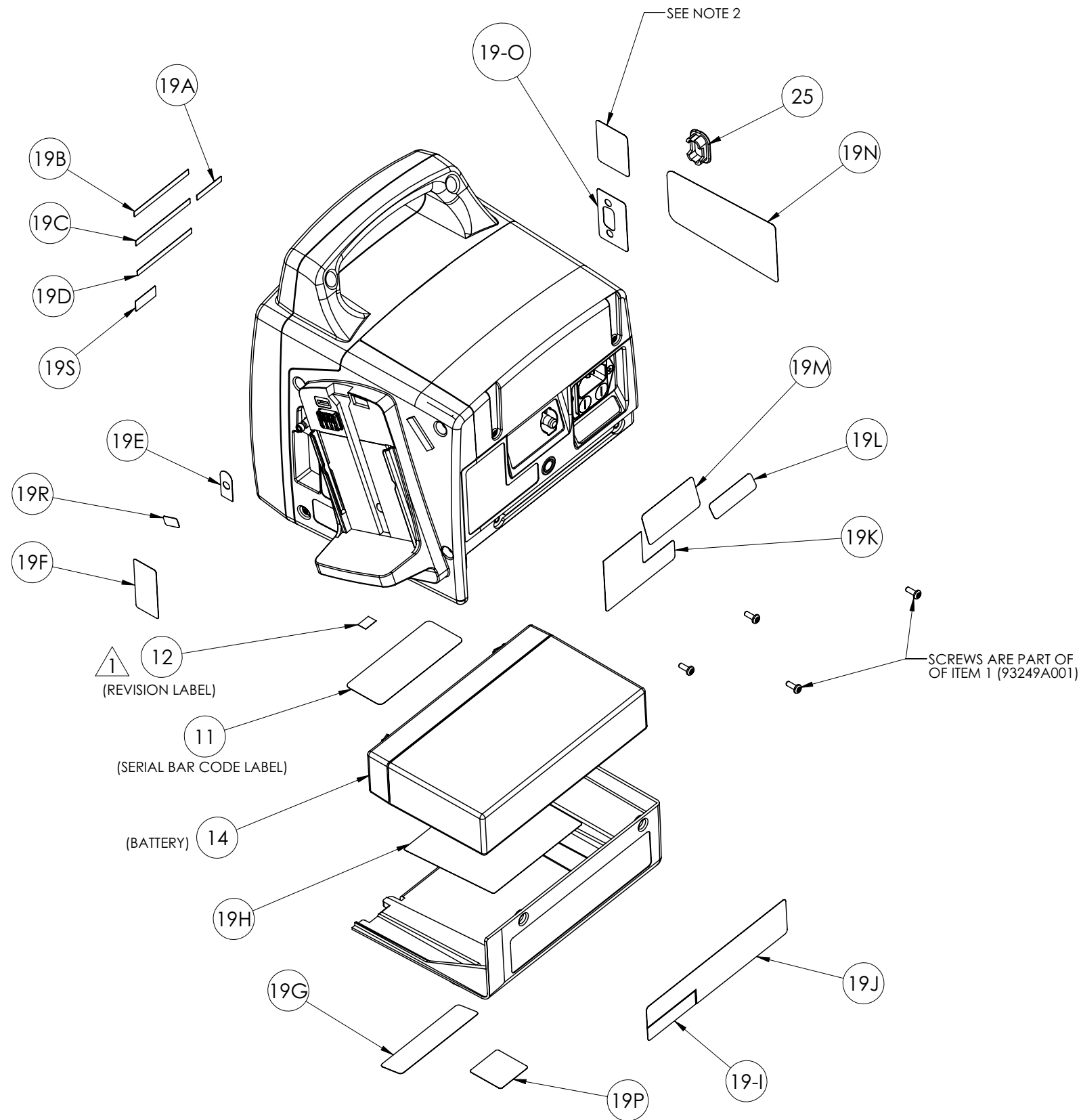

LABELS FROM SET (ITEM 19)

| ITEM | DESCRIPTION |
|------|----------------------------------|
| 19-A | LABEL, LANGUAGE, MENU |
| 19-B | LABEL, LANGUAGE, TREND/PRINT |
| 19-C | LABEL, LANGUAGE, NIBP CYCLE |
| 19-D | LABEL, LANGUAGE, NIBP START/STAT |
| 19-E | LABEL, NIBP FITTING |
| 19-F | LABEL, BLANK (NO SPO2) |
| 19-G | LABEL, CSI PATENT |
| 19-H | LABEL, BATTERY INSTALL |
| 19-I | LABEL, COUNTRY OF ORIGIN |
| 19-J | LABEL, CSI SUPPORT INFO |
| 19-K | LABEL, ETL SYMBOL |
| 19-L | LABEL, FUSE RATING |
| 19-M | LABEL, ELECTRICAL RATING |
| 19-N | LABEL, WARNINGS |
| 19-O | LABEL, SERIAL PORT |
| 19-P | LABEL, WEEE DIRECTIVE |
| 19-Q | LABEL, CE MARK |
| 19-R | LABEL, TEMP COVER |
| 19-S | LABEL, LANGUAGE TEMP ORAL/AX |

NOTE:

1. FOREIGN LANGUAGE LABELS INSTALLED AT THE CAT LEVEL. THEY ARE SHOWN ON THIS DRAWING FOR REFERENCE ONLY.
2. ADD QUALITY SEAL PN: 46036B101 (FROM CAT LEVEL BOM) TO MONITOR APPROXIMATELY ONE INCH ABOVE THE SERIAL PORT. IT SHOULD COVER THE FRONT AND REAR HOUSINGS.

VENDOR SHOULD COMPLY WITH THE FOLLOWING CSI QUALITY REQUIREMENTS: Q1, Q2, Q4, Q5, Q6, Q7, Q10, Q11 AND Q16. IN ADDITION THE QUALITY REQUIREMENTS Q9, Q13 AND Q17 APPLY. SEE CSI WEB SITE (www.csiusa.com/pdf/QA_Requirements.pdf) FOR THE DEFINITION OF THE QUALITY REQUIREMENTS.

SW

| DRAWN BY: SC | CHECK BY: | ENG. APPR.: |
|--|---------------------|--|
| DATE: 06-06-06 | RELEASE DATE: | Q.A. APPR.: |
| SCALE: NTS | DO NOT SCALE PRINT | MFG. APPR.: |
| TOLERANCE UNLESS OTHERWISE SPECIFIED: XX: +/- .020 XXX: +/- .005 ANGLES: +/- 1 DEGREE | | CONFIDENTIAL: THIS DOCUMENT CONTAINS CONFIDENTIAL INFORMATION AND MAY NOT BE COPIED OR DIVULGED WITHOUT WRITTEN CONSENT OF CRITICARE SYSTEMS, INC. |
| TITLE: FINAL ASSEMBLY 506NT3 | PART NO.: 93975A022 | REV. 1 |
| DIST: 301 | SHEET 2 OF 2 | |

| REVISIONS | | | |
|-----------|---------|---------------|-----|
| REV. | DATE | DESCRIPTION | BY |
| 1 | 12/8/06 | SEE ECN #8922 | DBL |

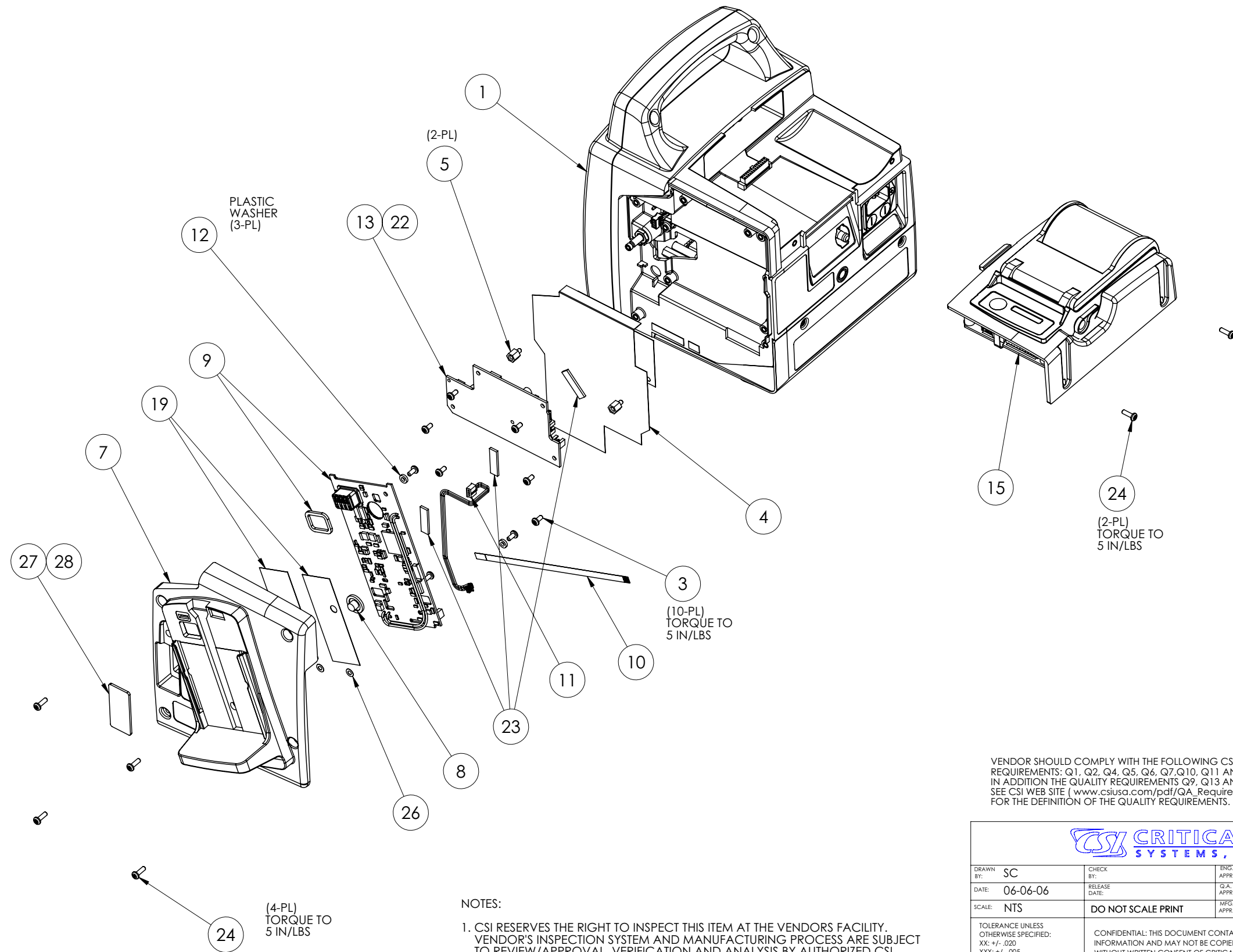

VENDOR SHOULD COMPLY WITH THE FOLLOWING CSI QUALITY REQUIREMENTS: Q1, Q2, Q4, Q5, Q6, Q7, Q10, Q11 AND Q16. IN ADDITION THE QUALITY REQUIREMENTS Q9, Q13 AND Q17 APPLY. SEE CSI WEB SITE (www.csiusa.com/pdf/QA_Requirements.pdf) FOR THE DEFINITION OF THE QUALITY REQUIREMENTS.

SW

| | | |
|--|--|------------------------------------|
| | | |
| DRAWN BY: SC | CHECK BY: | ENG. APPR.: S. COOGAN 6/12/06 |
| DATE: 06-06-06 | RELEASE DATE: | Q.A. APPR.: A. KAPLAN 6/12/06 |
| SCALE: NTS | DO NOT SCALE PRINT | MFG. APPR.: B. LEWANDOWSKI 6/13/06 |
| TOLERANCE UNLESS OTHERWISE SPECIFIED: XX: +/- .020 XXX: +/- .005 ANGLES: +/- 1 DEGREE | CONFIDENTIAL: THIS DOCUMENT CONTAINS CONFIDENTIAL INFORMATION AND MAY NOT BE COPIED OR DIVULGED WITHOUT WRITTEN CONSENT OF CRITICARE SYSTEMS, INC. | |
| TITLE: FINAL ASSEMBLY 506NTP3 | PART NO.: 93975A023 | REV. 1 |
| DIST: 301 | SHEET 1 OF 2 | |

NOTES:
1. CSI RESERVES THE RIGHT TO INSPECT THIS ITEM AT THE VENDORS FACILITY. VENDOR'S INSPECTION SYSTEM AND MANUFACTURING PROCESS ARE SUBJECT TO REVIEW/APPROVAL, VERIFICATION AND ANALYSIS BY AUTHORIZED CSI REPRESENTATIVES. ALL CHANGES IN DESIGN, COMPONENTS, PROCESSES OR FABRICATION MUST BE AUTHORIZED IN WRITING BY CSI PRIOR TO IMPLEMENTATION. ALL DEVIATIONS FROM DRAWINGS, SPECIFICATIONS, OR OTHER REQUIREMENTS MUST BE REPORTED TO CSI FOR APPROVAL PRIOR TO SHIPMENT.

| REVISIONS | | | |
|-----------|------|-------------|----|
| REV. | DATE | DESCRIPTION | BY |
| | | | |

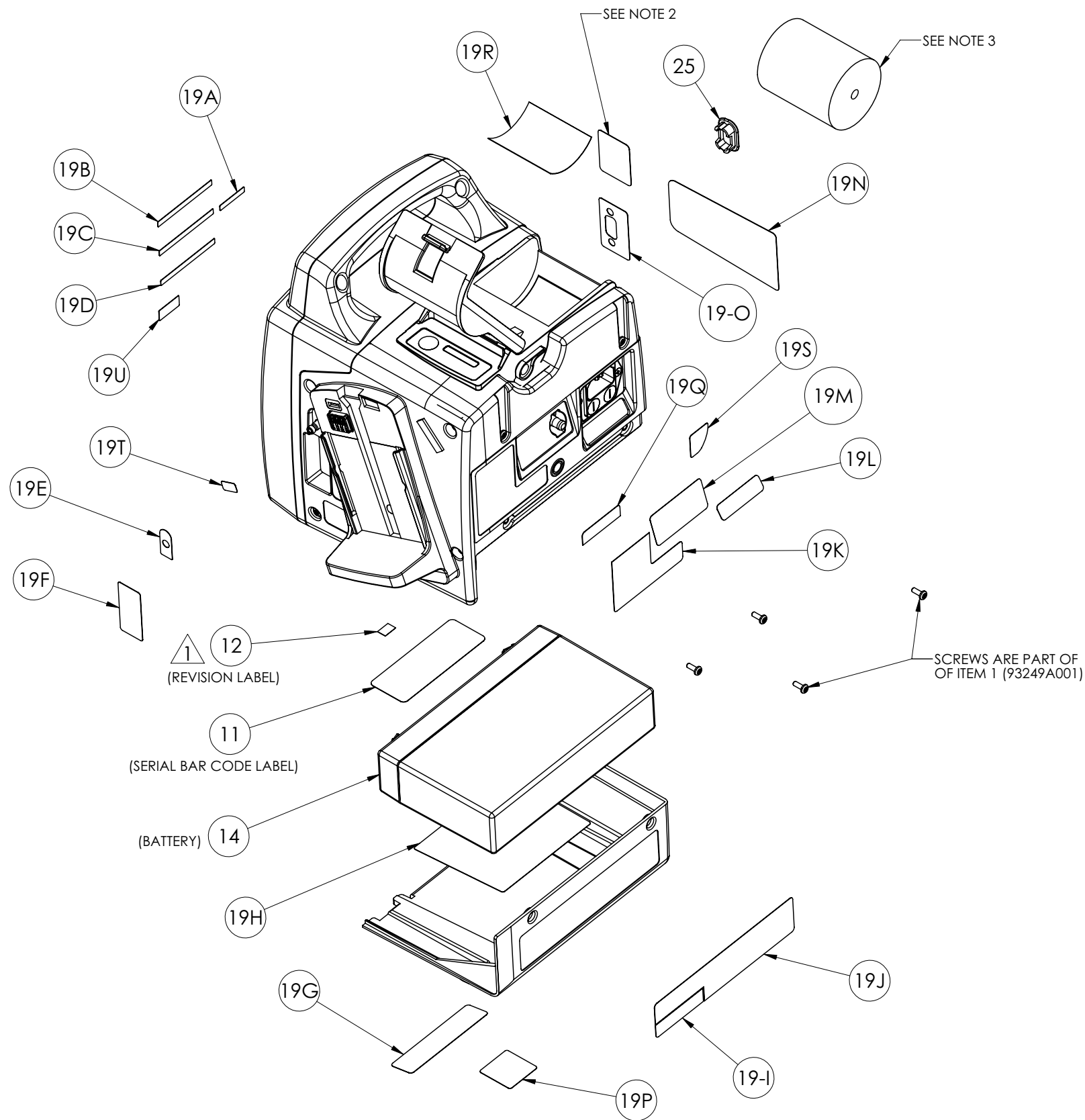

LABELS FROM SET (ITEM 19)

| ITEM | DESCRIPTION |
|------|----------------------------------|
| 19-A | LABEL, LANGUAGE, MENU |
| 19-B | LABEL, LANGUAGE, TREND/PRINT |
| 19-C | LABEL, LANGUAGE, NIBP CYCLE |
| 19-D | LABEL, LANGUAGE, NIBP START/STAT |
| 19-E | LABEL, NIBP FITTING |
| 19-F | LABEL, BLANK (NO SPO2) |
| 19-G | LABEL, CSI PATENT |
| 19-H | LABEL, BATTERY INSTALL |
| 19-I | LABEL, COUNTRY OF ORIGIN |
| 19-J | LABEL, CSISUPPORT INFO |
| 19-K | LABEL, ETL SYMBOL |
| 19-L | LABEL, FUSE RATING |
| 19-M | LABEL, ELECTRICAL RATING |
| 19-N | LABEL, WARNINGS |
| 19-O | LABEL, SERIAL PORT |
| 19-P | LABEL, WEEE DIRECTIVE |
| 19-Q | LABEL, CE MARK |
| 19-R | LABEL, PAPER LOADING |
| 19-S | LABEL, PAPER RELEASE |
| 19-T | LABEL, TEMP COVER |
| 19-U | LABEL, LANGUAGE TEMP ORAL/AX |

NOTE:

1. FOREIGN LANGUAGE LABELS INSTALLED AT THE CAT LEVEL. THEY ARE SHOWN ON THIS DRAWING FOR REFERENCE ONLY.
2. ADD QUALITY SEAL PN: 46036B101 (FROM CAT LEVEL BOM) TO MONITOR APPROXIMATELY ONE INCH ABOVE THE SERIAL PORT. IT SHOULD COVER THE FRONT AND REAR HOUSINGS.
3. INSTALL PRINTER PAPER PN: 40065B002 (CAT LEVEL) INTO PRINTER HOUSING.

VENDOR SHOULD COMPLY WITH THE FOLLOWING CSI QUALITY REQUIREMENTS: Q1, Q2, Q4, Q5, Q6, Q7, Q10, Q11 AND Q16. IN ADDITION THE QUALITY REQUIREMENTS Q9, Q13 AND Q17 APPLY. SEE CSI WEB SITE (www.csiusa.com/pdf/QA_Requirements.pdf) FOR THE DEFINITION OF THE QUALITY REQUIREMENTS.

SW

| | | |
|--|---------------------|--|
| | | |
| DRAWN BY: SC | CHECK BY: | ENG. APPR.: |
| DATE: 06-06-06 | RELEASE DATE: | Q.A. APPR.: |
| SCALE: NTS | DO NOT SCALE PRINT | |
| TOLERANCE UNLESS OTHERWISE SPECIFIED: XX: +/- .020 XXX: +/- .005 ANGLES: +/- 1 DEGREE | | CONFIDENTIAL: THIS DOCUMENT CONTAINS CONFIDENTIAL INFORMATION AND MAY NOT BE COPIED OR DIVULGED WITHOUT WRITTEN CONSENT OF CRITICARE SYSTEMS, INC. |
| TITLE: FINAL ASSEMBLY 506NTP3 | PART NO.: 93975A023 | REV. 1 |
| DST: 301 | | SHEET 2 OF 2 |

| REVISIONS | | | |
|-----------|---------|---------------|-----|
| REV. | DATE | DESCRIPTION | BY |
| 1 | 12/8/06 | SEE ECN #8922 | DBL |

TEMPERATURE
CABLE

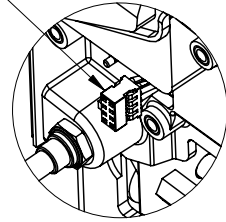

DETAIL A

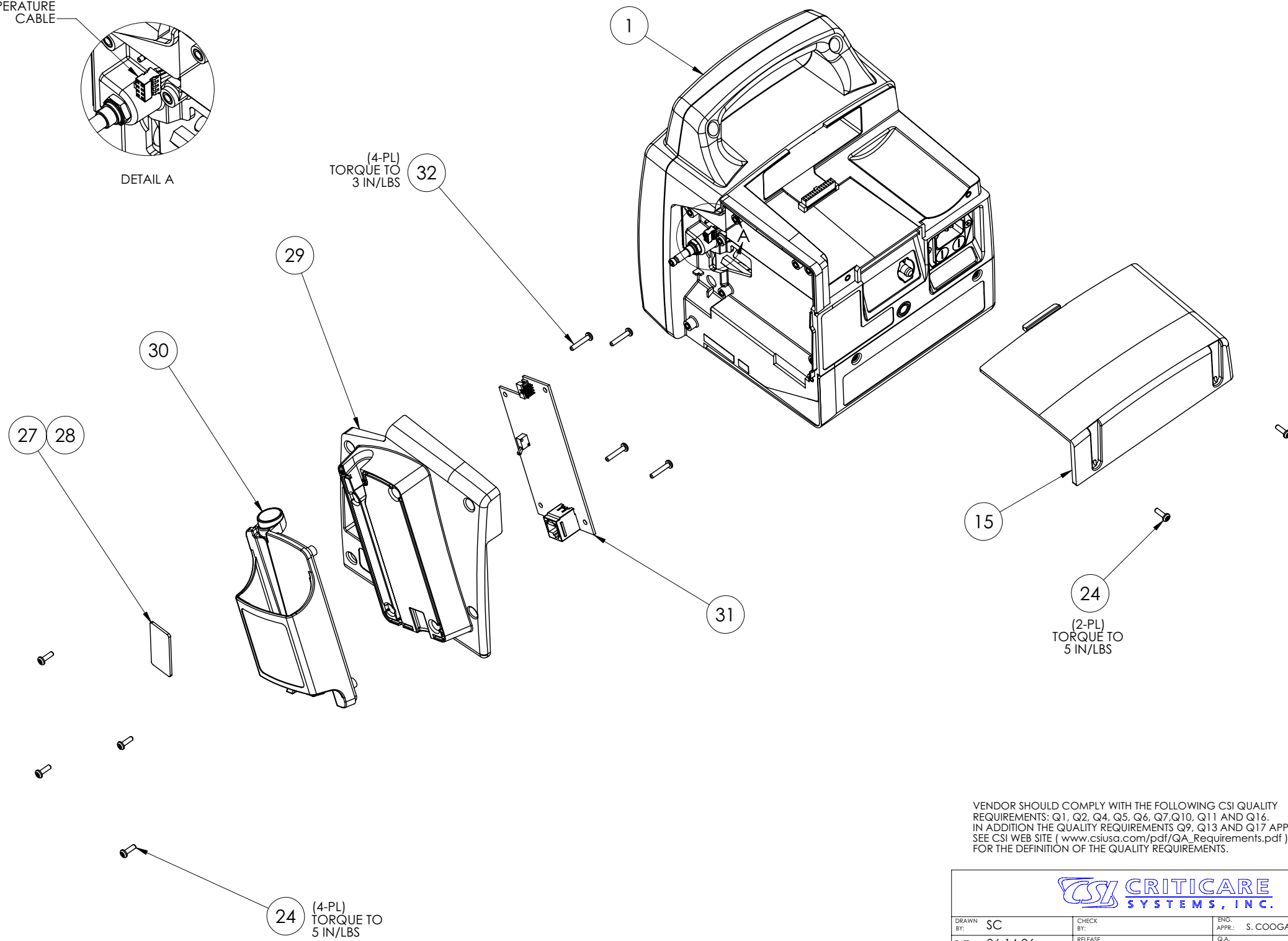

VENDOR SHOULD COMPLY WITH THE FOLLOWING CSI QUALITY REQUIREMENTS: Q1, Q2, Q4, Q5, Q6, Q7, Q10, Q11 AND Q16. IN ADDITION THE QUALITY REQUIREMENTS Q9, Q13 AND Q17 APPLY. SEE CSI WEB SITE (www.csiusa.com/pdf/QA_Requirements.pdf) FOR THE DEFINITION OF THE QUALITY REQUIREMENTS.

SW



| | | |
|--|--------------------|--|
| DRAWN BY: SC | CHECK BY: | ENG. APPR.: S. COOGAN 7/24/06 |
| DATE: 06-14-06 | RELEASE DATE: | Q.A. APPR.: A. KAPLAN 7/31/06 |
| SCALE: NTS | DO NOT SCALE PRINT | MFG. APPR.: B. LEWANDOWSKI 7/25/06 |
| TOLERANCE UNLESS OTHERWISE SPECIFIED: XX: +/- .020 XXX: +/- .005 ANGLES: +/- 1 DEGREE | | CONFIDENTIAL: THIS DOCUMENT CONTAINS CONFIDENTIAL INFORMATION AND MAY NOT BE COPIED OR DIVULGED WITHOUT WRITTEN CONSENT OF CRITICARE SYSTEMS, INC. |
| TITLE: FINAL ASSEMBLY 506NV3 NIBP, TURBO TEMP | | PART NO.: 93975A024 |
| | | REV. 1 |
| DST: 302 | | SHEET 1 OF 2 |

| REVISIONS | | | |
|-----------|------|-------------|----|
| REV. | DATE | DESCRIPTION | BY |
| | | | |

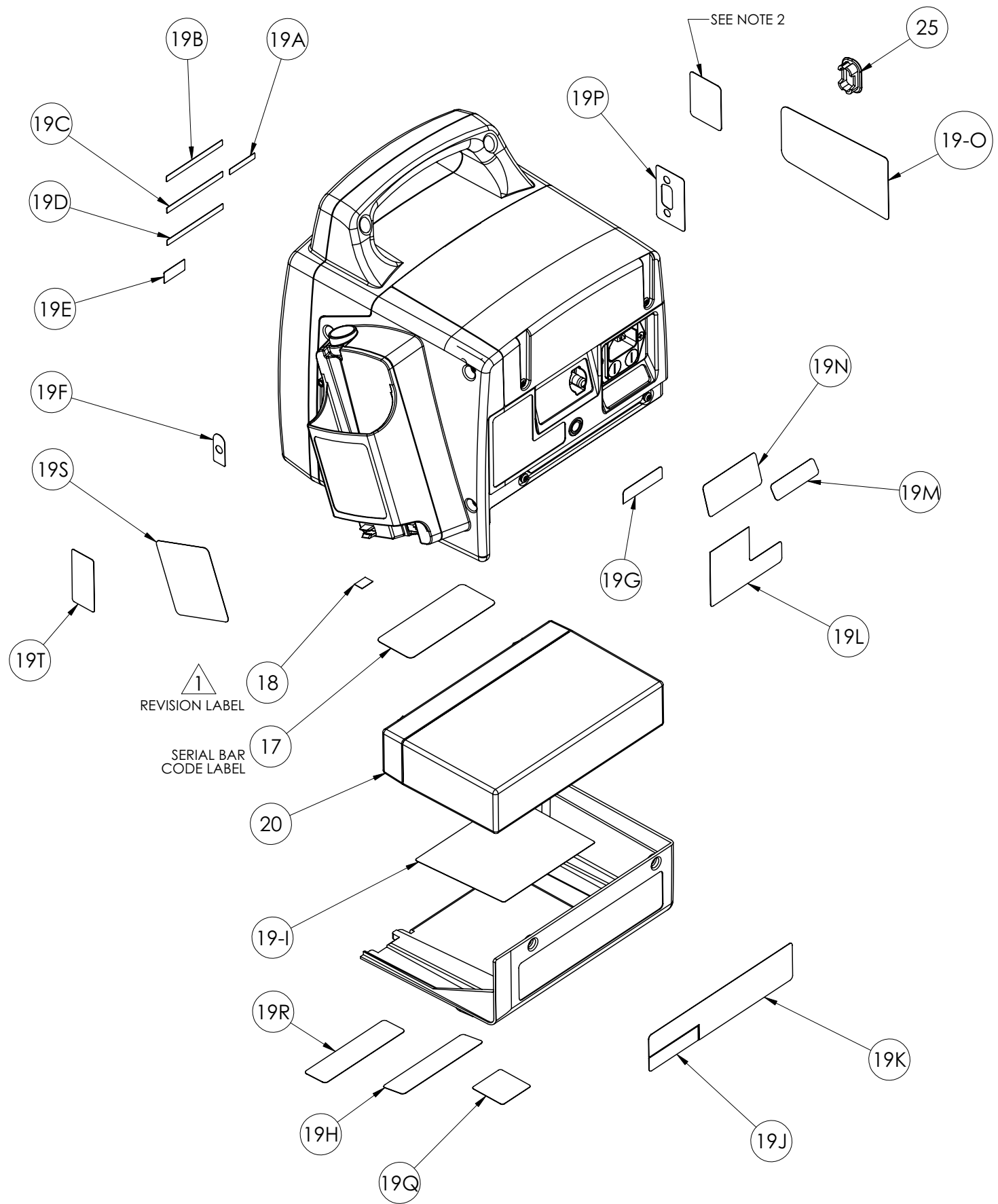

| LABELS FROM SET (ITEM 19) | |
|---------------------------|----------------------------------|
| ITEM | DESCRIPTION |
| 19-A | LABEL, LANGUAGE, MENU |
| 19-B | LABEL, LANGUAGE, TREND/PRINT |
| 19-C | LABEL, LANGUAGE, NIBP CYCLE |
| 19-D | LABEL, LANGUAGE, NIBP START/STAT |
| 19-E | LABEL, LANGUAGE, TEMP. ORAL/AX |
| 19-F | LABEL, NIBP FITTING |
| 19-G | LABEL, BLANK |
| 19-H | LABEL, CSI PATENT |
| 19-I | LABEL, BATTERY INSTALL |
| 19-J | LABEL, COUNTRY OF ORIGIN |
| 19-K | LABEL, CSI SUPPORT INFO |
| 19-L | LABEL, ETL SYMBOL |
| 19-M | LABEL, FUSE RATING |
| 19-N | LABEL, ELECTRICAL RATING |
| 19-O | LABEL, WARNINGS |
| 19-P | LABEL, SERIAL PORT |
| 19-Q | LABEL, WEEE DIRECTIVE |
| 19-R | LABEL, ALARIS PATENT |
| 19-S | LABEL, ALARIS TURBO TEMP |
| 19-T | LABEL, BLANK O2 PORT |

NOTE:

1. FOREIGN LANGUAGE LABELS INSTALLED AT THE CAT LEVEL. THEY ARE SHOWN ON THIS DRAWING FOR REFERENCE ONLY.
2. ADD QUALITY SEAL PN: 46036B101 (FROM CAT LEVEL BOM) TO MONITOR APPROXIMATELY ONE INCH ABOVE THE SERIAL PORT. IT SHOULD COVER THE FRONT AND REAR HOUSINGS.

VENDOR SHOULD COMPLY WITH THE FOLLOWING CSI QUALITY REQUIREMENTS: Q1, Q2, Q4, Q5, Q6, Q7, Q10, Q11 AND Q16. IN ADDITION THE QUALITY REQUIREMENTS Q9, Q13 AND Q17 APPLY. SEE CSI WEB SITE (www.csiusa.com/pdf/QA_Requirements.pdf) FOR THE DEFINITION OF THE QUALITY REQUIREMENTS.

SW

| | | |
|--|------------------------|--|
| | | |
| DRAWN BY: SC | CHECK BY: | ENG. APPR.: |
| DATE: 06-14-06 | RELEASE DATE: | Q.A. APPR.: |
| SCALE: NTS | DO NOT SCALE PRINT | |
| TOLERANCE UNLESS OTHERWISE SPECIFIED: XX: +/- .020 XXX: +/- .005 ANGLES: +/- 1 DEGREE | | CONFIDENTIAL: THIS DOCUMENT CONTAINS CONFIDENTIAL INFORMATION AND MAY NOT BE COPIED OR DIVULGED WITHOUT WRITTEN CONSENT OF CRITICARE SYSTEMS, INC. |
| TITLE: FINAL ASSEMBLY 506NV3 NIBP, TURBO TEMP | PART NO.: 93975A024 | REV.: 1 |
| DST: 302 | | SHEET 2 OF 2 |

| REVISIONS | | | |
|-----------|---------|---------------|-----|
| REV. | DATE | DESCRIPTION | BY |
| 1 | 12/8/06 | SEE ECN #8922 | DBL |

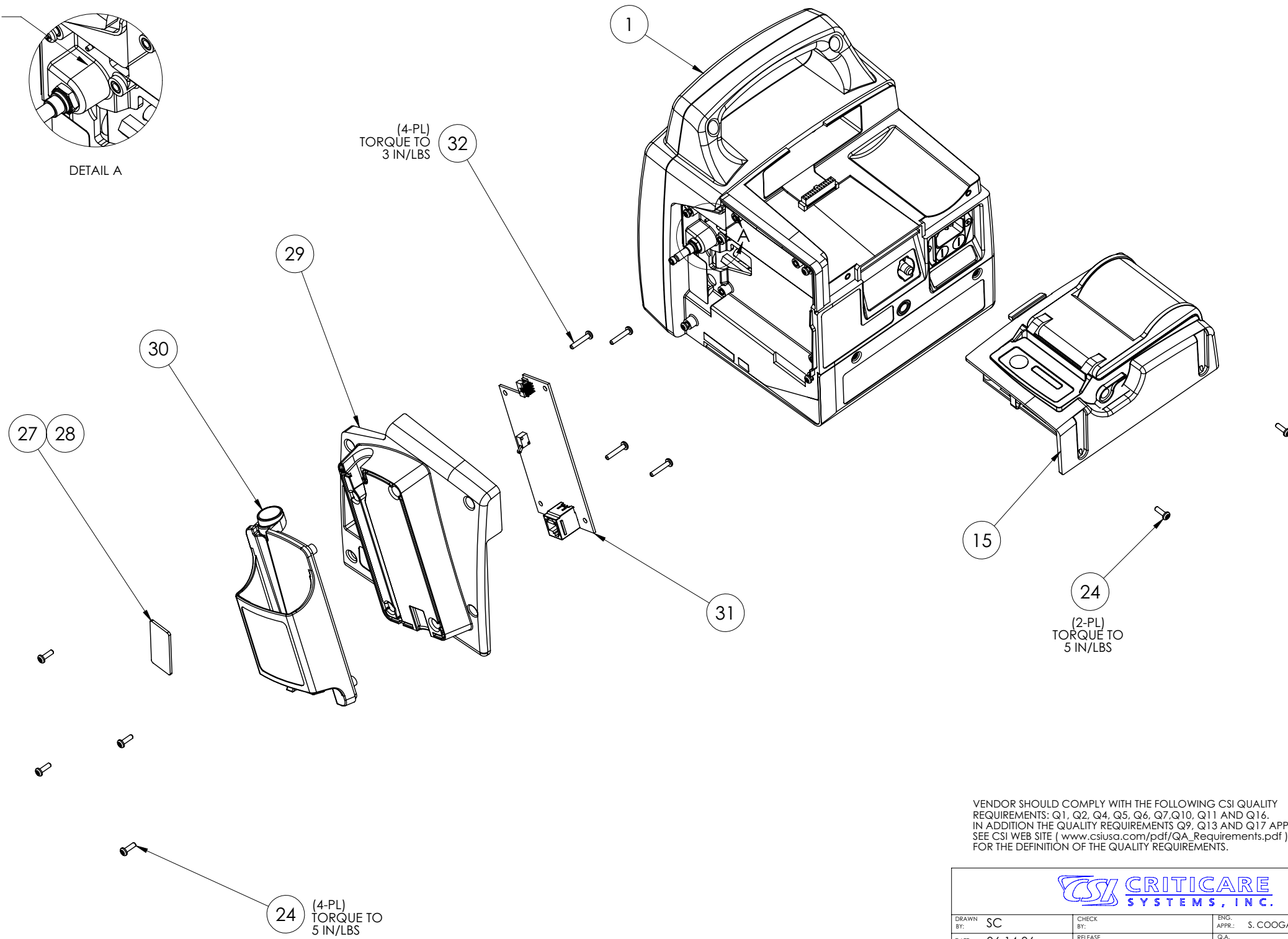
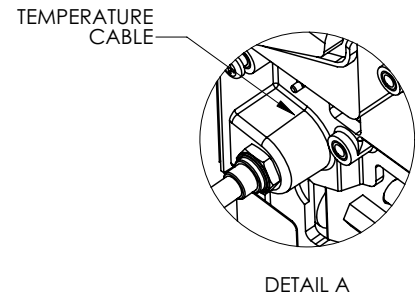

VENDOR SHOULD COMPLY WITH THE FOLLOWING CSI QUALITY REQUIREMENTS: Q1, Q2, Q4, Q5, Q6, Q7, Q10, Q11 AND Q16. IN ADDITION THE QUALITY REQUIREMENTS Q9, Q13 AND Q17 APPLY. SEE CSI WEB SITE (www.csiusa.com/pdf/QA_Requirements.pdf) FOR THE DEFINITION OF THE QUALITY REQUIREMENTS.

SW



| | | |
|--|--------------------|--|
| DRAWN BY: SC | CHECK BY: | ENG. APPR.: S. COOGAN 7/24/06 |
| DATE: 06-14-06 | RELEASE DATE: | Q.A. APPR.: A. KAPLAN 7/31/06 |
| SCALE: NTS | DO NOT SCALE PRINT | MFG. APPR.: B. LEWANDOWSKI 7/25/06 |
| TOLERANCE UNLESS OTHERWISE SPECIFIED: XX: +/- .020 XXX: +/- .005 ANGLES: +/- 1 DEGREE | | CONFIDENTIAL: THIS DOCUMENT CONTAINS CONFIDENTIAL INFORMATION AND MAY NOT BE COPIED OR DIVULGED WITHOUT WRITTEN CONSENT OF CRITICARE SYSTEMS, INC. |
| TITLE: FINAL ASSEMBLY 506NVP3 NIBP, TURBO TEMP, PRNTR | | PART NO.: 93975A025 |
| DIST: 302 | | REV. 1 |
| SHEET 1 OF 2 | | |

| REVISIONS | | | |
|-----------|------|-------------|----|
| REV. | DATE | DESCRIPTION | BY |
| | | | |

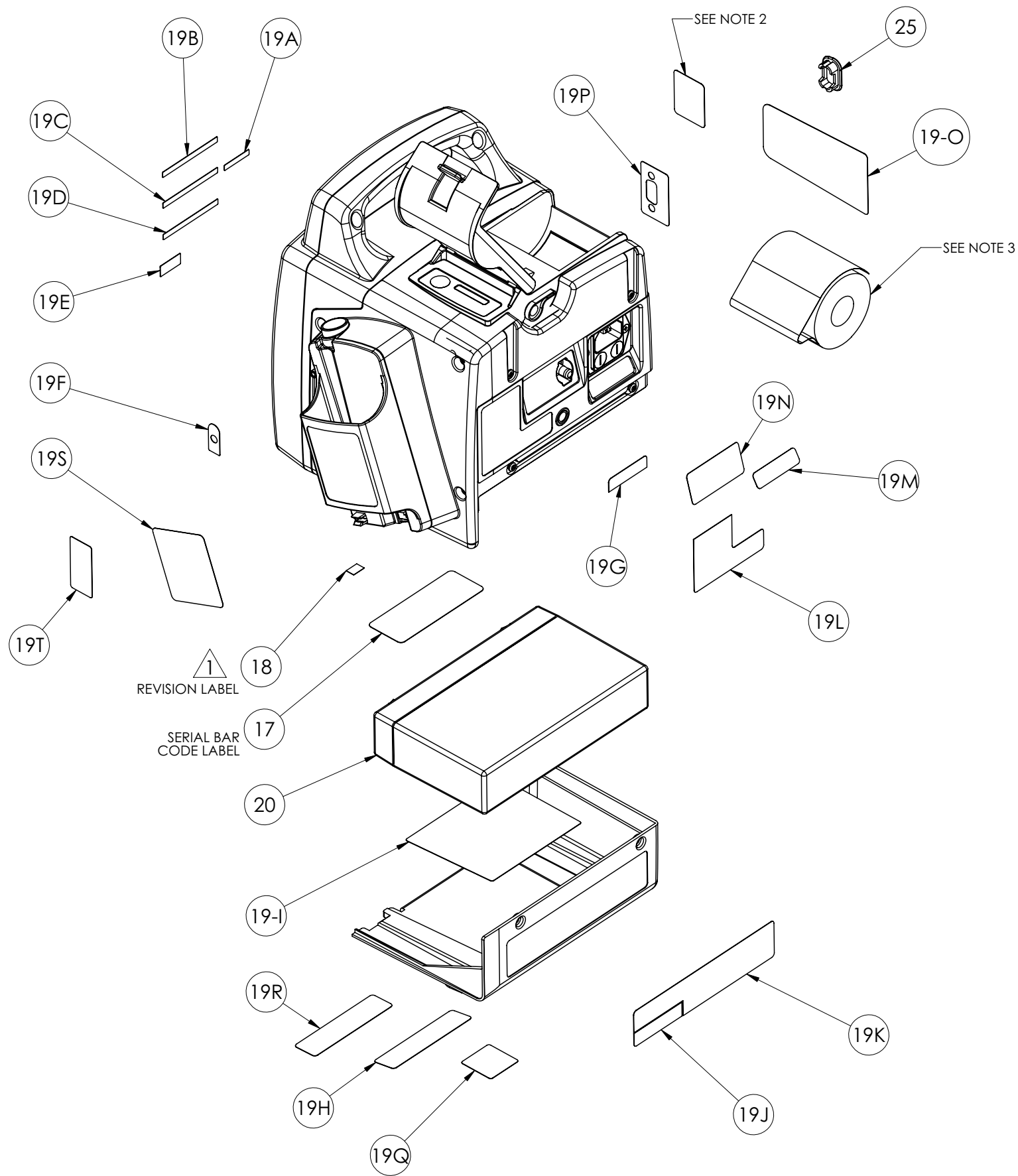

| LABELS FROM SET (ITEM 19) | |
|---------------------------|----------------------------------|
| ITEM | DESCRIPTION |
| 19-A | LABEL, LANGUAGE, MENU |
| 19-B | LABEL, LANGUAGE, TREND/PRINT |
| 19-C | LABEL, LANGUAGE, NIBP CYCLE |
| 19-D | LABEL, LANGUAGE, NIBP START/STAT |
| 19-E | LABEL, LANGUAGE, TEMP. ORAL/AX |
| 19-F | LABEL, NIBP FITTING |
| 19-G | LABEL, BLANK |
| 19-H | LABEL, CSI PATENT |
| 19-I | LABEL, BATTERY INSTALL |
| 19-J | LABEL, COUNTRY OF ORIGIN |
| 19-K | LABEL, CSI SUPPORT INFO |
| 19-L | LABEL, ETL SYMBOL |
| 19-M | LABEL, FUSE RATING |
| 19-N | LABEL, ELECTRICAL RATING |
| 19-O | LABEL, WARNINGS |
| 19-P | LABEL, SERIAL PORT |
| 19-Q | LABEL, WEEE DIRECTIVE |
| 19-R | LABEL, ALARIS PATENT |
| 19-S | LABEL, ALARIS TURBO TEMP |
| 19-T | LABEL, BLANK O2 PORT |

NOTE:

1. FOREIGN LANGUAGE LABELS INSTALLED AT THE CAT LEVEL. THEY ARE SHOWN ON THIS DRAWING FOR REFERENCE ONLY.
2. ADD QUALITY SEAL PN: 46036B101 (FROM CAT LEVEL BOM) TO MONITOR APPROXIMATELY ONE INCH ABOVE THE SERIAL PORT. IT SHOULD COVER THE FRONT AND REAR HOUSINGS.
3. INSTALL PRINTER PAPER PN: 40065B002 (CAT LEVEL) INTO PRINTER HOUSING.

VENDOR SHOULD COMPLY WITH THE FOLLOWING CSI QUALITY REQUIREMENTS: Q1, Q2, Q4, Q5, Q6, Q7, Q10, Q11 AND Q16. IN ADDITION THE QUALITY REQUIREMENTS Q9, Q13 AND Q17 APPLY. SEE CSI WEB SITE (www.csiusa.com/pdf/QA_Requirements.pdf) FOR THE DEFINITION OF THE QUALITY REQUIREMENTS.

SW

| | | |
|--|--------------------|--|
| | | |
| DRAWN BY: SC | CHECK BY: | ENG. APPR.: |
| DATE: 06-14-06 | RELEASE DATE: | Q.A. APPR.: |
| SCALE: NTS | DO NOT SCALE PRINT | MFG. APPR.: |
| TOLERANCE UNLESS OTHERWISE SPECIFIED: XX: +/- .020 XXX: +/- .005 ANGLES: +/- 1 DEGREE | | CONFIDENTIAL: THIS DOCUMENT CONTAINS CONFIDENTIAL INFORMATION AND MAY NOT BE COPIED OR DIVULGED WITHOUT WRITTEN CONSENT OF CRITICARE SYSTEMS, INC. |
| TITLE: FINAL ASSEMBLY 506NVP3 NIBP, TURBO TEMP, PRNTR | | PART NO.: 93975A025 |
| | | REV. 1 |
| DST: 302 | | SHEET 2 OF 2 |

| PART NO. | REV. | DESCRIPTION |
|-------------|------|---------------------------------------|
| △ 93949A001 | 4 | BASE ASSEMBLY, NON-TEMPERATURE |
| 93949A002 | 4 | BASE ASSEMBLY, TEMPERATURE |
| △ 93949A003 | 1 | BASE ASSEMBLY, NO SPO2, NON-TEMP |
| 93949A004 | 1 | BASE ASSEMBLY, NO SPO2, TEMPERATURE |
| △ 93949A005 | 0 | BASE ASSEMBLY, NO SPO2, PLASMA CENTER |

NOTES:

1. CSI RESERVES THE RIGHT TO INSPECT THIS ITEM AT THE VENDORS FACILITY. VENDOR'S INSPECTION SYSTEM AND MANUFACTURING PROCESS ARE SUBJECT TO REVIEW/APPROVAL, VERIFICATION AND ANALYSIS BY AUTHORIZED CSI REPRESENTATIVES. ALL CHANGES IN DESIGN, COMPONENTS, PROCESSES OR FABRICATION MUST BE AUTHORIZED IN WRITING BY CSI PRIOR TO IMPLEMENTATION. ALL DEVIATIONS FROM DRAWINGS, SPECIFICATIONS, OR OTHER REQUIREMENTS MUST BE REPORTED TO CSI FOR APPROVAL PRIOR TO SHIPMENT.

| REVISIONS | | | |
|-----------|----------|---------------|-----|
| REV. | DATE | DESCRIPTION | BY |
| 1 | 11/17/05 | SEE ECN #8590 | DBL |
| 2 | 01/24/06 | SEE ECN #8652 | ILR |
| 3 | 05/03/06 | SEE ECN #8741 | SC |
| 4 | 06/30/06 | SEE ECN #8908 | SC |

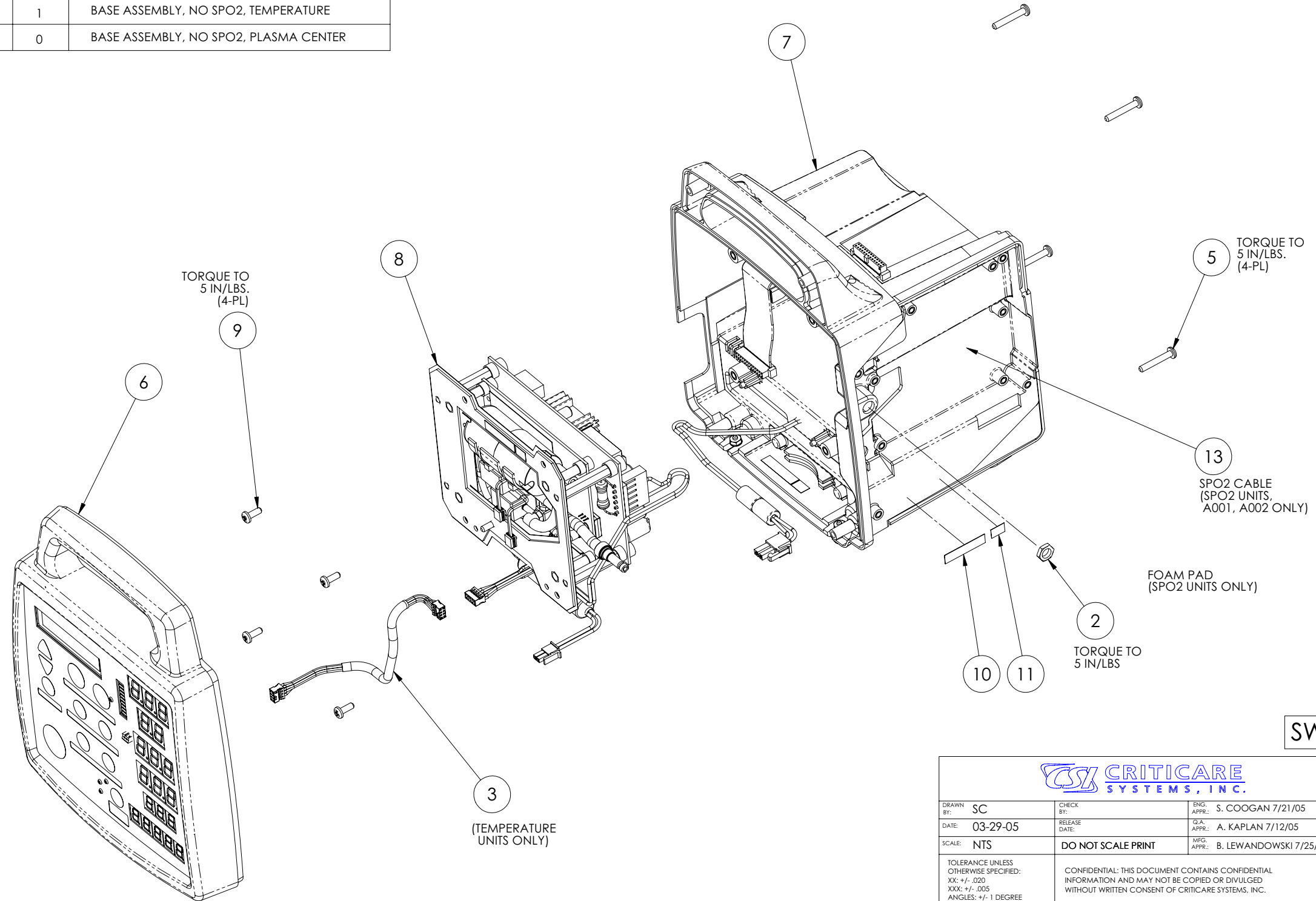

SW

CRITICARE SYSTEMS, INC.

| | | |
|----------------|--------------------|------------------------------------|
| DRAWN BY: SC | CHECK BY: | ENG. APPR.: S. COOGAN 7/21/05 |
| DATE: 03-29-05 | RELEASE DATE: | Q.A. APPR.: A. KAPLAN 7/12/05 |
| SCALE: NTS | DO NOT SCALE PRINT | MFG. APPR.: B. LEWANDOWSKI 7/25/05 |

TOLERANCE UNLESS OTHERWISE SPECIFIED:
 XX: +/- .020
 XXX: +/- .005
 ANGLES: +/- 1 DEGREE

CONFIDENTIAL: THIS DOCUMENT CONTAINS CONFIDENTIAL INFORMATION AND MAY NOT BE COPIED OR DIVULGED WITHOUT WRITTEN CONSENT OF CRITICARE SYSTEMS, INC.

| | | |
|---------------------------------------|-------------------------------|-------------------|
| TITLE: BASE ASSEMBLY, 506N3 | PART NO.: 93949AXXX | REV.: 4 |
| DIST: 302 | SHEET 1 OF 1 | |

| REVISIONS | | | |
|-----------|----------|---------------|-----|
| REV. | DATE | DESCRIPTION | BY |
| 1 | 09/21/05 | SEE ECN #8522 | SC |
| 2 | 11/09/05 | SEE ECN #8569 | RWK |
| 3 | 01/23/06 | SEE ECN #8652 | TLR |
| 4 | 05/03/06 | SEE ECN #8741 | SC |
| 5 | 05/30/06 | SEE ECN #8908 | SC |
| 6 | 12/7/06 | SEE ECN #8922 | DBL |

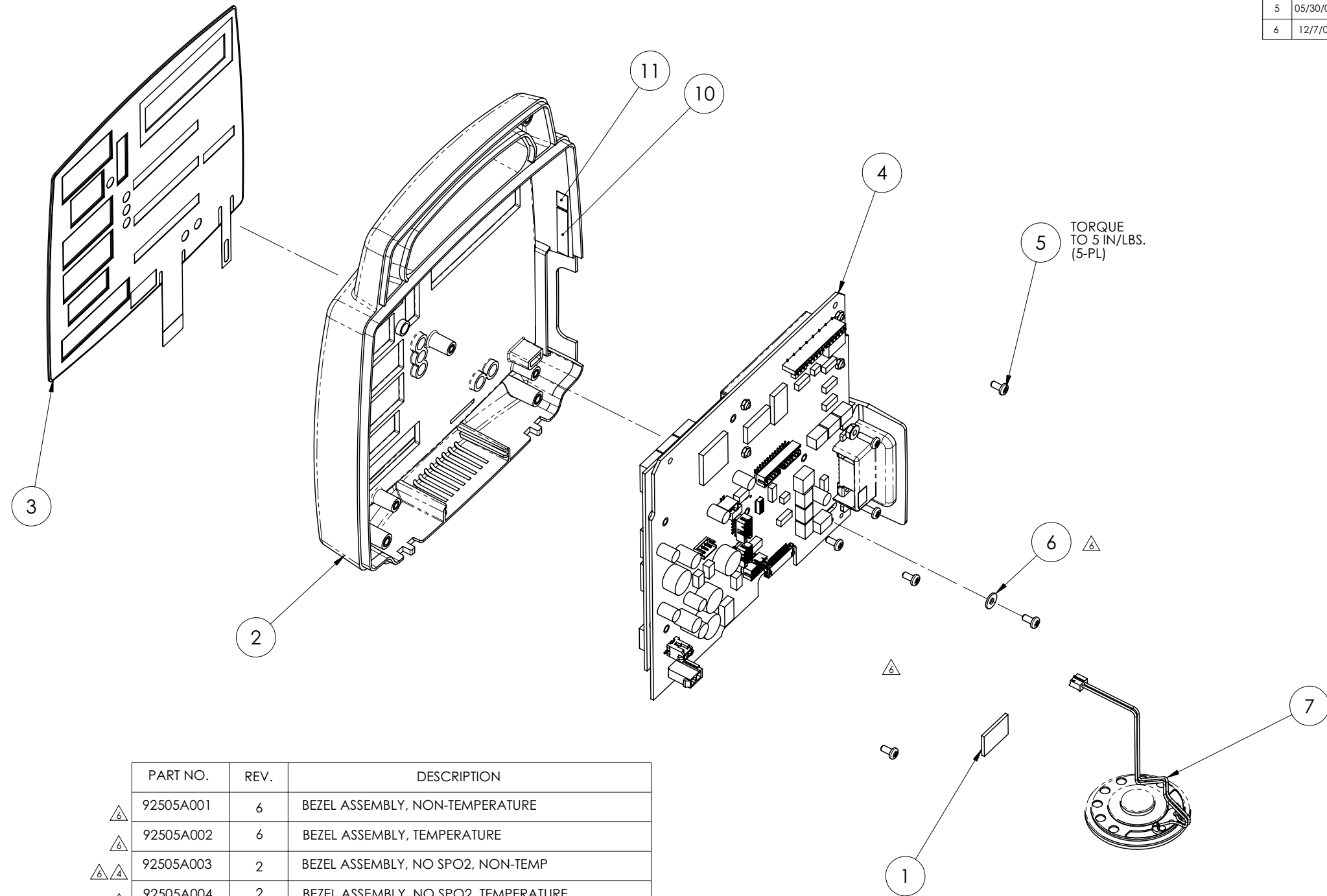

| | PART NO. | REV. | DESCRIPTION |
|-------|-----------|------|--|
| △6 | 92505A001 | 6 | BEZEL ASSEMBLY, NON-TEMPERATURE |
| △6 | 92505A002 | 6 | BEZEL ASSEMBLY, TEMPERATURE |
| △6 △4 | 92505A003 | 2 | BEZEL ASSEMBLY, NO SPO2, NON-TEMP |
| △6 | 92505A004 | 2 | BEZEL ASSEMBLY, NO SPO2, TEMPERATURE |
| △6 △5 | 92505A005 | 1 | BEZEL ASSEMBLY, NO SPO2, PLASMA CENTER |

NOTES:

1. CSI RESERVES THE RIGHT TO INSPECT THIS ITEM AT THE VENDORS FACILITY. VENDOR'S INSPECTION SYSTEM AND MANUFACTURING PROCESSES ARE SUBJECT TO REVIEW/APPROVAL, VERIFICATION AND ANALYSIS BY AUTHORIZED CSI REPRESENTATIVES. ALL CHANGES IN DESIGN, COMPONENTS, PROCESSES OR FABRICATION MUST BE AUTHORIZED, IN WRITING, BY CSI PRIOR TO IMPLEMENTATION. ALL DEVIATIONS FROM DRAWINGS, SPECIFICATIONS OR OTHER REQUIREMENTS MUST BE REPORTED TO CSI FOR APPROVAL PRIOR TO SHIPMENT.

SW

| | | |
|--|--------------------|--|
| | | |
| DRAWN BY: SC | CHECK BY: | ENG. APPR.: S.COOGAN 07/25/05 |
| DATE: 03-29-05 | RELEASE DATE: | Q.A. APPR.: A.KAPLAN 07/21/05 |
| SCALE: NTS | DO NOT SCALE PRINT | MFG. APPR.: LEWANDOWSKI 07/20/05 |
| TOLERANCE UNLESS OTHERWISE SPECIFIED: XX: +/- .020 XXX: +/- .005 ANGLES: +/- 1 DEGREE | | CONFIDENTIAL: THIS DOCUMENT CONTAINS CONFIDENTIAL INFORMATION AND MAY NOT BE COPIED OR DIVULGED WITHOUT WRITTEN CONSENT OF CRITICARE SYSTEMS, INC. |
| TITLE: BEZEL ASSEMBLY 506N3 | | PART NO.: 92505AXXX |
| | | REV. 6 |
| DST: 302 | | SHEET 1 OF 1 |

| REVISIONS | | | |
|-----------|----------|---------------|-----|
| REV. | DATE | DESCRIPTION | BY |
| 1 | 11/16/05 | SEE ECN #8590 | RWK |
| 2 | 11/29/05 | SEE ECN #8614 | RWK |
| 3 | 01/30/06 | SEE ECN #8652 | TLR |
| 4 | 06/30/06 | SEE ECN #8908 | SC |

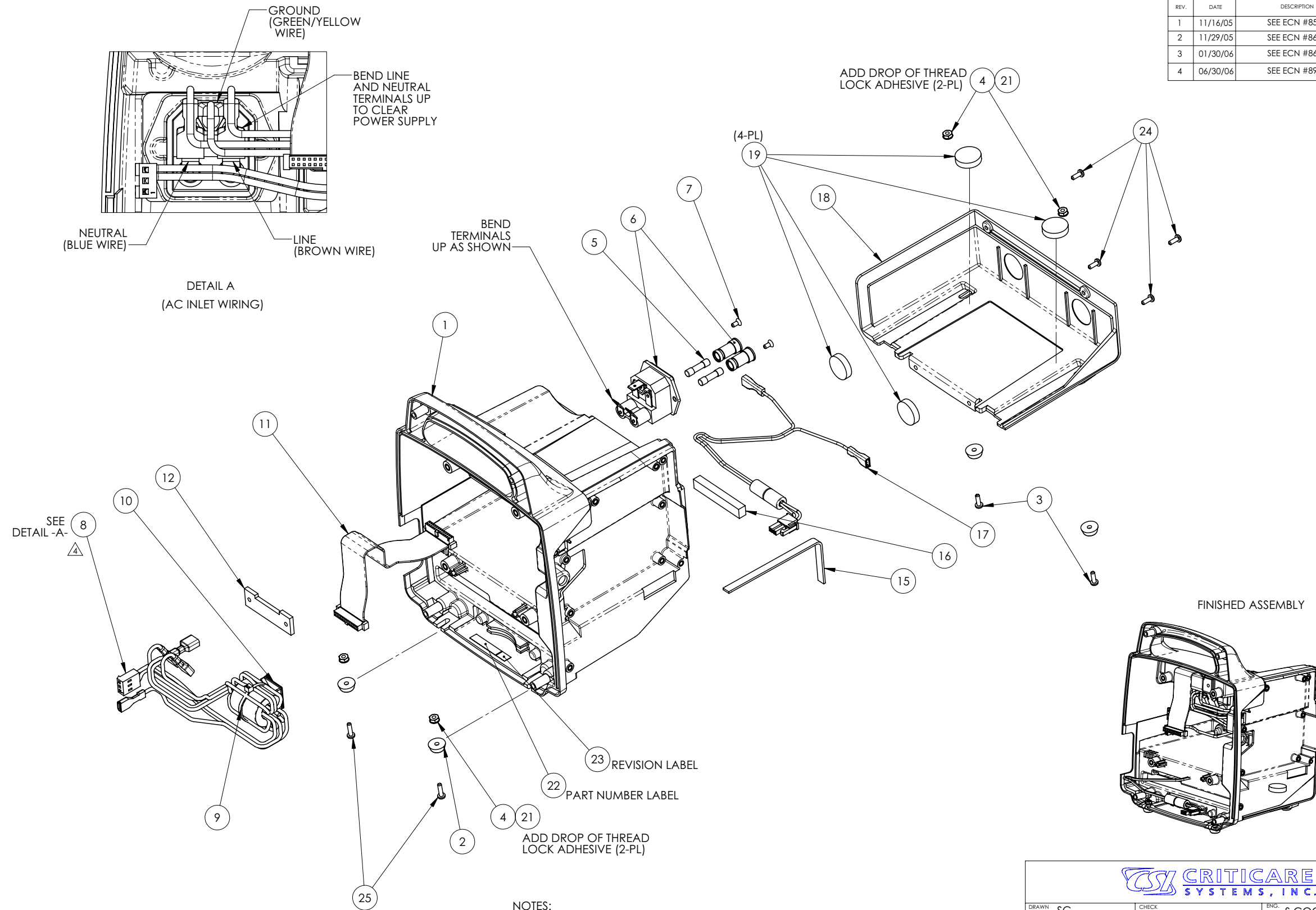

NOTES:

1. CSI RESERVES THE RIGHT TO INSPECT THIS ITEM AT THE VENDORS FACILITY. VENDOR'S INSPECTION SYSTEM AND MANUFACTURING PROCESS ARE SUBJECT TO REVIEW/APPROVAL, VERIFICATION AND ANALYSIS BY AUTHORIZED CSI REPRESENTATIVES. ALL CHANGES IN DESIGN, COMPONENTS, PROCESSES OR FABRICATION MUST BE AUTHORIZED IN WRITING BY CSI PRIOR TO IMPLEMENTATION. ALL DEVIATIONS FROM DRAWINGS, SPECIFICATIONS, OR OTHER REQUIREMENTS MUST BE REPORTED TO CSI FOR APPROVAL PRIOR TO SHIPMENT.
2. TORQUE ALL SCREWS TO 5 IN/LBS.

| DRAWN BY: SC | CHECK BY: | ENG. APPR.: S.COOGAN | 07/21/05 |
|--|--------------------|--|----------|
| DATE: 03-29-05 | RELEASE DATE: | Q.A. APPR.: A.KAPLAN | 07/21/05 |
| SCALE: NTS | DO NOT SCALE PRINT | MFG. APPR.: LEWANDOWSKI | 07/19/05 |
| TOLERANCE UNLESS OTHERWISE SPECIFIED: XX: +/- .020 XXX: +/- .005 ANGLES: +/- 1 DEGREE | | CONFIDENTIAL: THIS DOCUMENT CONTAINS CONFIDENTIAL INFORMATION AND MAY NOT BE COPIED OR DIVULGED WITHOUT WRITTEN CONSENT OF CRITICARE SYSTEMS, INC. | |
| TITLE: REAR HOUSING ASSEM. 506N3 | | PART NO.: 93249A001 | REV. 4 |
| DST: 302 | | SHEET 1 OF 1 | |

APPLY PART NO. &
REV. LABELS TO FRONT
SURFACE OF CHASSIS

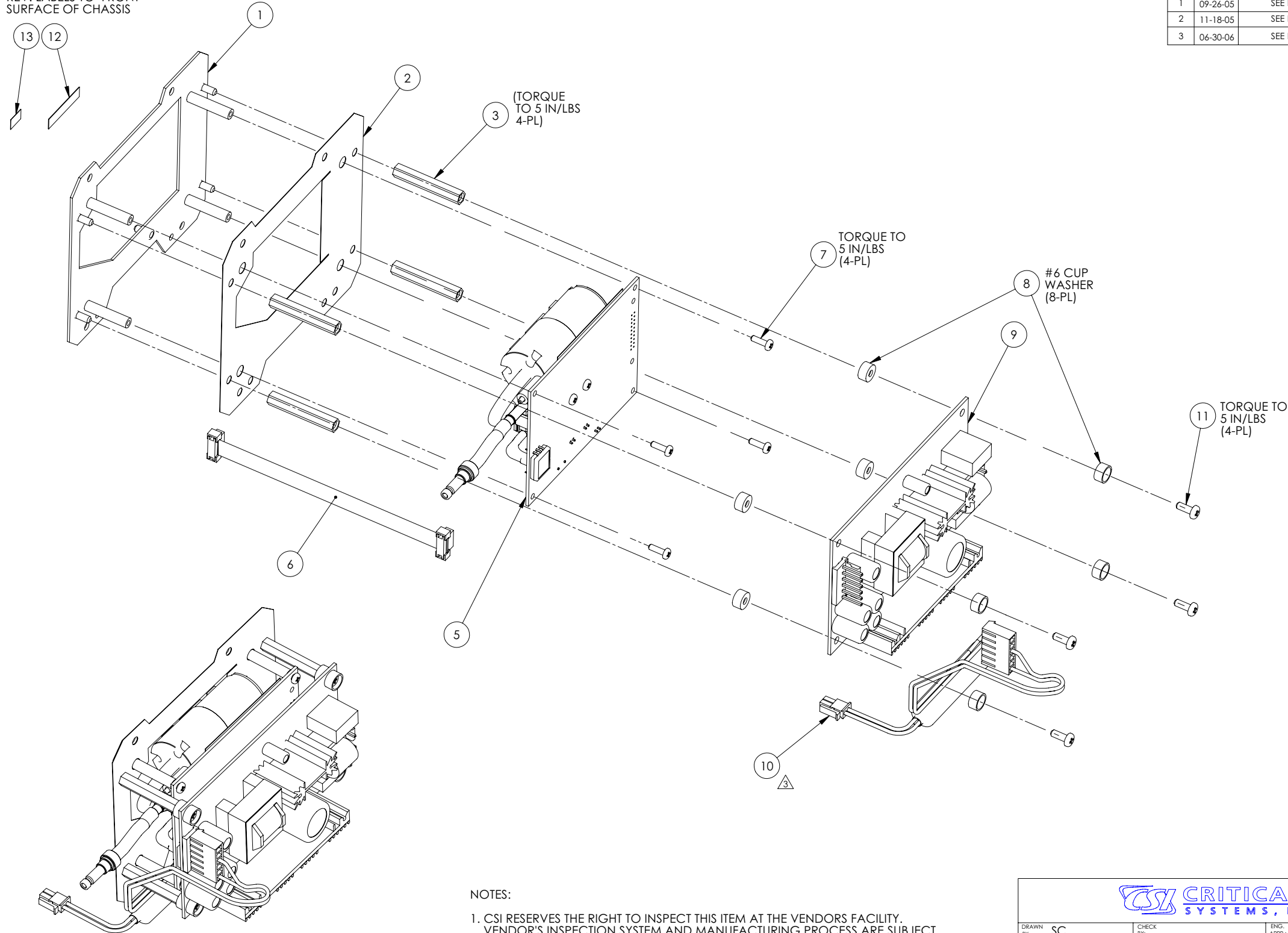

| REVISIONS | | | |
|-----------|----------|---------------|-----|
| REV. | DATE | DESCRIPTION | BY |
| 1 | 09-26-05 | SEE ECN #8527 | SC |
| 2 | 11-18-05 | SEE ECN #8590 | RWK |
| 3 | 06-30-06 | SEE ECN #8908 | SC |

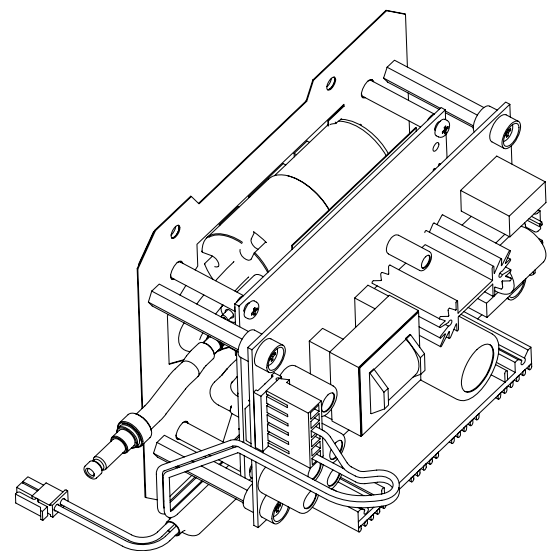

DETAIL -A-
FINISHED CHASSIS ASSEMBLY

NOTES:

1. CSI RESERVES THE RIGHT TO INSPECT THIS ITEM AT THE VENDORS FACILITY. VENDOR'S INSPECTION SYSTEM AND MANUFACTURING PROCESS ARE SUBJECT TO REVIEW/APPROVAL, VERIFICATION AND ANALYSIS BY AUTHORIZED CSI REPRESENTATIVES. ALL CHANGES IN DESIGN, COMPONENTS, PROCESSES OR FABRICATION MUST BE AUTHORIZED IN WRITING BY CSI PRIOR TO IMPLEMENTATION. ALL DEVIATIONS FROM DRAWINGS, SPECIFICATIONS, OR OTHER REQUIREMENTS MUST BE REPORTED TO CSI FOR APPROVAL PRIOR TO SHIPMENT.

SW

CRITICARE SYSTEMS, INC.

| | | | |
|--|--------------------|--|----------|
| DRAWN BY: SC | CHECK BY: | ENG. APPR.: S.COOGAN | 07/21/05 |
| DATE: 03-29-05 | RELEASE DATE: | Q.A. APPR.: A.KAPLAN | 07/21/05 |
| SCALE: 1:1 | DO NOT SCALE PRINT | MFG. APPR.: LEWANDOWSKI | 07/18/05 |
| TOLERANCE UNLESS OTHERWISE SPECIFIED: XX: +/- .020 XXX: +/- .005 ANGLES: +/- 1 DEGREE | | CONFIDENTIAL: THIS DOCUMENT CONTAINS CONFIDENTIAL INFORMATION AND MAY NOT BE COPIED OR DIVULGED WITHOUT WRITTEN CONSENT OF CRITICARE SYSTEMS, INC. | |
| TITLE: CHASSIS ASSEMBLY 506N3 | | PART NO.: 95746A001 | REV.: 3 |
| DIST: 302 | | SHEET 1 OF 1 | |

| REVISIONS | | | |
|-----------|----------|---------------|-----|
| REV. | DATE | DESCRIPTION | BY |
| 1 | 8/30/05 | SEE ECN #8492 | DBL |
| 2 | 11/18/05 | SEE ECN #8590 | RWK |
| 3 | 3/9/06 | SEE ECN #8707 | DBL |
| 4 | 07/06/06 | SEE ECN #8834 | RWK |

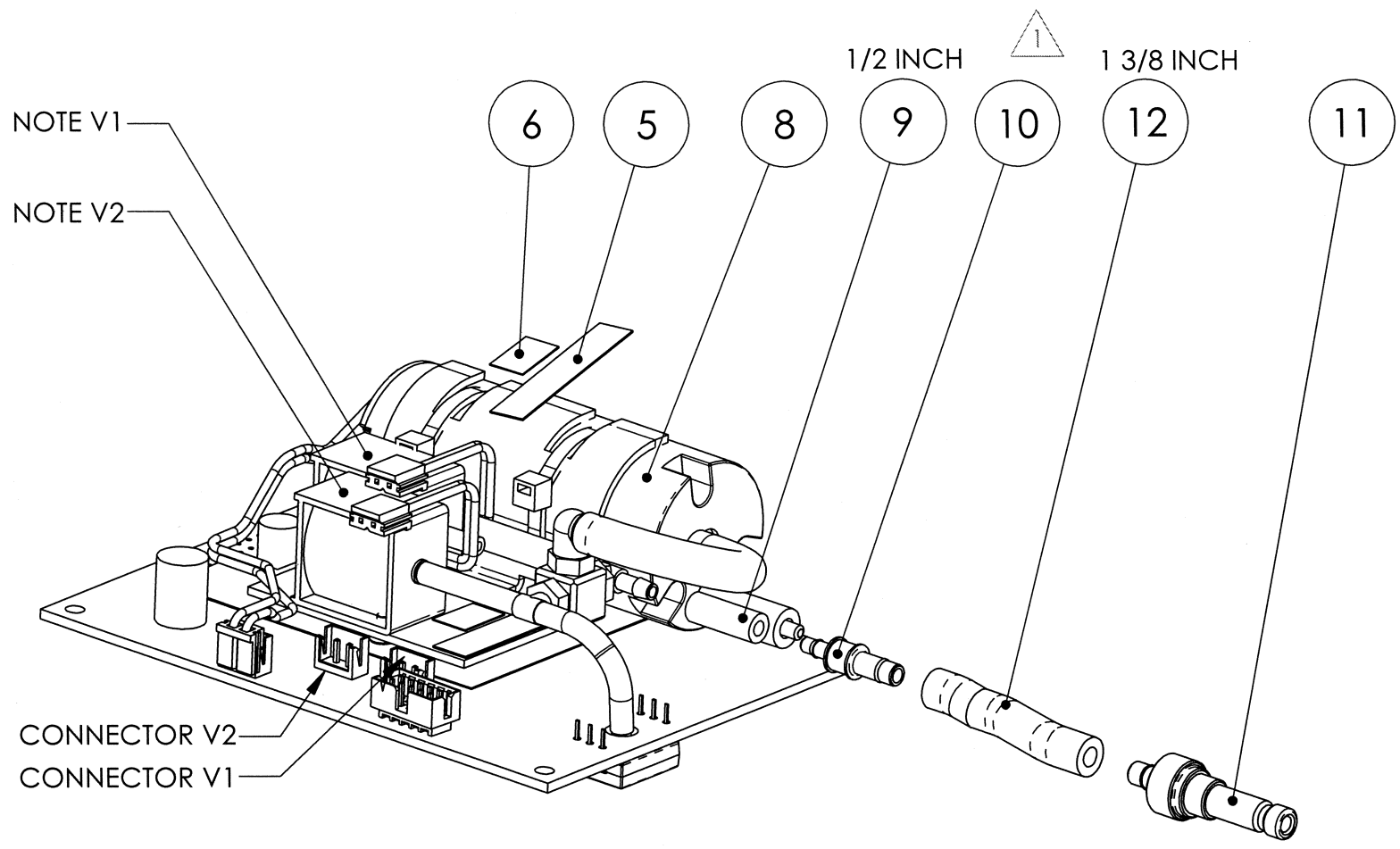

NOTES:

1. CSI RESERVES THE RIGHT TO INSPECT THIS ITEM AT THE VENDORS FACILITY. VENDOR'S INSPECTION SYSTEM AND MANUFACTURING PROCESS ARE SUBJECT TO REVIEW/APPROVAL, VERIFICATION AND ANALYSIS BY AUTHORIZED CSI REPRESENTATIVES. ALL CHANGES IN DESIGN, COMPONENTS, PROCESSES OR FABRICATION MUST BE AUTHORIZED IN WRITING BY CSI PRIOR TO IMPLEMENTATION. ALL DEVIATIONS FROM DRAWINGS, SPECIFICATIONS, OR OTHER REQUIREMENTS MUST BE REPORTED TO CSI FOR APPROVAL PRIOR TO SHIPMENT.

 2. SEE 93947P003 FOR ASSEMBLY INSTRUCTIONS

SW



| | | | |
|----------------|------------------------------|----------------------------|---------|
| DRAWN BY: SC | CHECK BY: <i>ECZ 7/26/06</i> | ENG. APPR.: S. COOGAN | 8/12/05 |
| DATE: 03-22-05 | RELEASE DATE: | Q.A. APPR.: A. KAPLAN | 8/12/05 |
| SCALE: 1:1 | DO NOT SCALE PRINT | MFG. APPR.: B. LEWANDOWSKI | 8/12/05 |

TOLERANCE UNLESS OTHERWISE SPECIFIED:
 XX: +/- .020
 XXX: +/- .005
 ANGLES: +/- 1 DEGREE

CONFIDENTIAL: THIS DOCUMENT CONTAINS CONFIDENTIAL INFORMATION AND MAY NOT BE COPIED OR DIVULGED WITHOUT WRITTEN CONSENT OF CRITICARE SYSTEMS, INC.

| | | |
|---|------------------------|------------|
| TITLE: ASSEMBLY, NIBP MODULE 506N3 | PART NO.: 93947A003 | REV.: 4 |
| DIST: 302 | SHEET 1 OF 1 | |

| REVISIONS | | | |
|-----------|----------|---------------|-----|
| REV. | DATE | DESCRIPTION | BY |
| 1 | 8/31/05 | SEE ECN #8492 | DBL |
| 2 | 11/16/05 | SEE ECN #8590 | RWK |
| 3 | 3/8/06 | SEE ECN #8707 | DBL |
| 4 | 08/15/06 | SEE ECN #8908 | RWK |

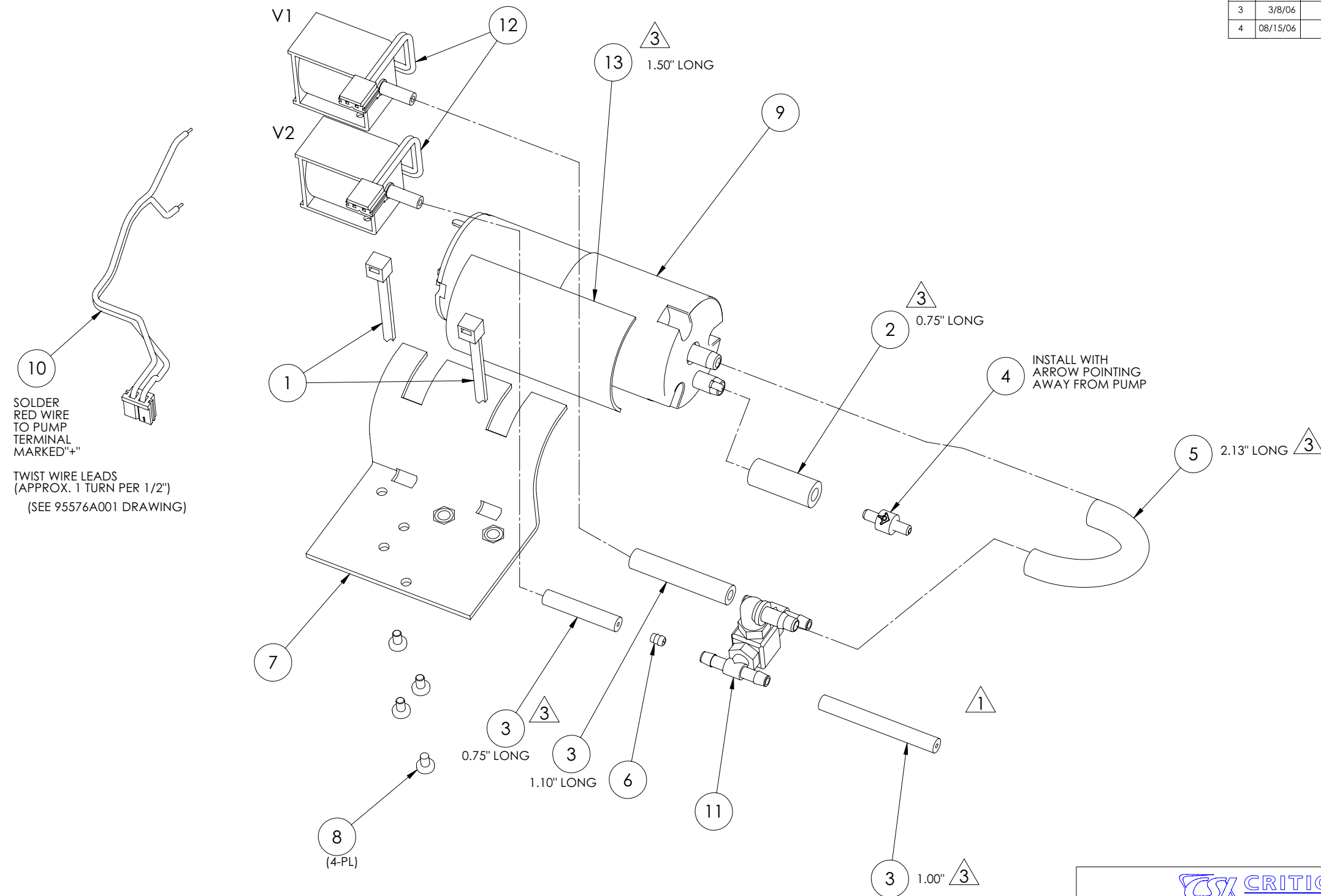

10
SOLDER RED WIRE TO PUMP TERMINAL MARKED "+"
TWIST WIRE LEADS (APPROX. 1 TURN PER 1/2") (SEE 95576A001 DRAWING)

NOTES:
1. CSI RESERVES THE RIGHT TO INSPECT THIS ITEM AT THE VENDORS FACILITY. VENDOR'S INSPECTION SYSTEM AND MANUFACTURING PROCESS ARE SUBJECT TO REVIEW/APPROVAL, VERIFICATION AND ANALYSIS BY AUTHORIZED CSI REPRESENTATIVES. ALL CHANGES IN DESIGN, COMPONENTS, PROCESSES OR FABRICATION MUST BE AUTHORIZED IN WRITING BY CSI PRIOR TO IMPLEMENTATION. ALL DEVIATIONS FROM DRAWINGS, SPECIFICATIONS, OR OTHER REQUIREMENTS MUST BE REPORTED TO CSI FOR APPROVAL PRIOR TO SHIPMENT.

SW

CRITICARE SYSTEMS, INC.

| | | |
|--|--------------------|--|
| DRAWN BY: SC | CHECK BY: | ENG. APPR.: S. COOGAN 7/21/05 |
| DATE: 03-22-05 | RELEASE DATE: | Q.A. APPR.: A. KAPLAN 7/21/05 |
| SCALE: NTS | DO NOT SCALE PRINT | MFG. APPR.: B. LEWANDOWSKI 7/19/05 |
| TOLERANCE UNLESS OTHERWISE SPECIFIED: XX: +/- .020 XXX: +/- .005 ANGLES: +/- 1 DEGREE | | CONFIDENTIAL: THIS DOCUMENT CONTAINS CONFIDENTIAL INFORMATION AND MAY NOT BE COPIED OR DIVULGED WITHOUT WRITTEN CONSENT OF CRITICARE SYSTEMS, INC. |
| TITLE: ASSEMBLY, NIBP PNEUMATIC 506N3 | | PART NO.: 95597A002 |
| DIST: 302 | | REV.: 4 |
| SHEET 1 OF 1 | | |

TORQUE TO
2 IN./LBS.
(4-PL)

5

4

(4-PL)
1

9

10

TORQUE TO
5 IN./LBS.
(2-PL)

11

13

14

4

TORQUE TO
5 IN./LBS.
(2-PL)

3

15

TORQUE TO
1 IN. LBS.
APPLY LOCTITE
(4-PL)

12

| REVISIONS | | | |
|-----------|----------|---------------|-----|
| REV. | DATE | DESCRIPTION | BY |
| 1 | 10/26/05 | SEE ECN #8563 | DBL |
| 2 | 01/23/06 | SEE ECN #8652 | TLR |
| 3 | 07/05/06 | SEE ECN #8834 | RWK |
| 4 | 12/7/06 | SEE ECN #8922 | DBL |

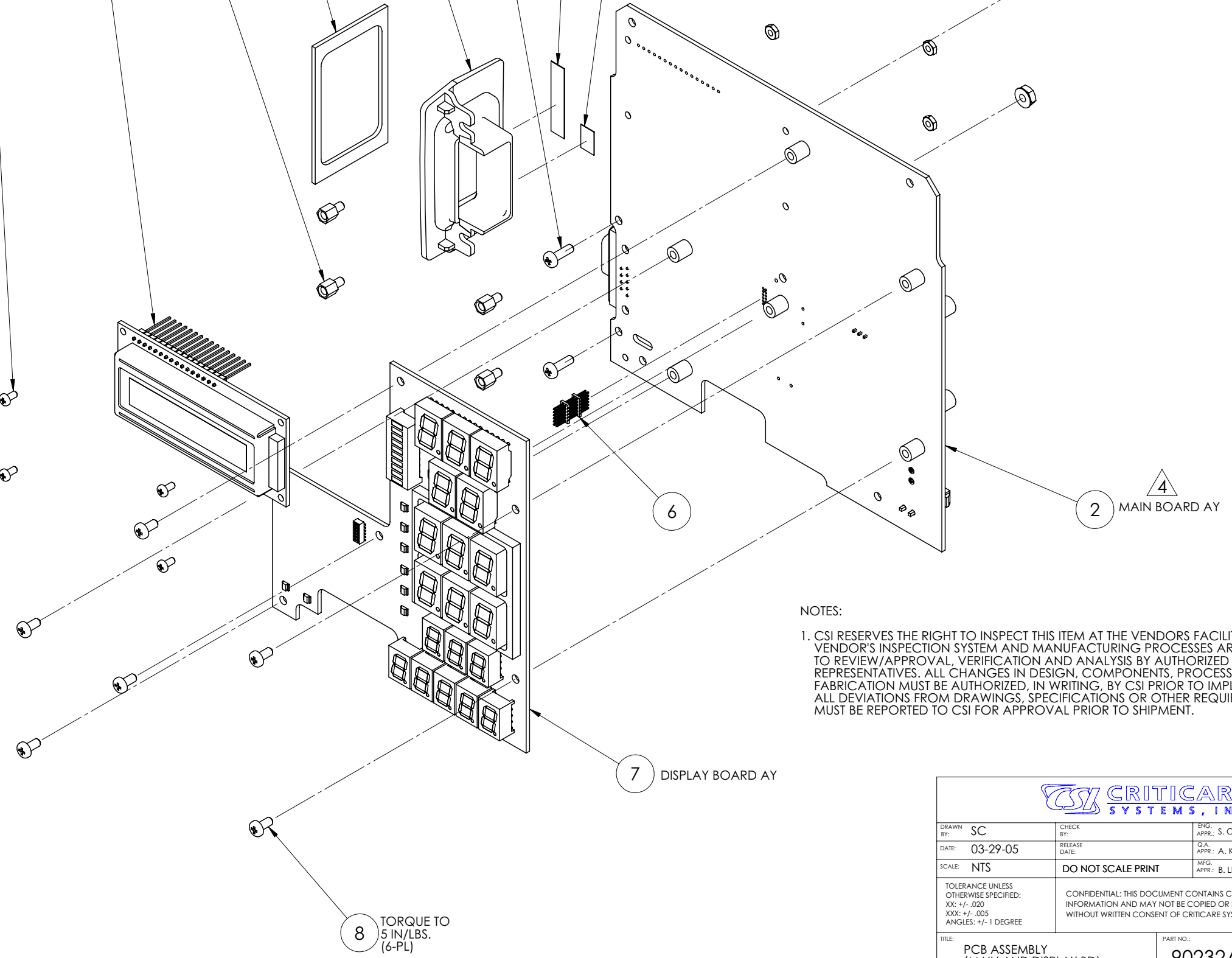

NOTES:

1. CSI RESERVES THE RIGHT TO INSPECT THIS ITEM AT THE VENDORS FACILITY. VENDOR'S INSPECTION SYSTEM AND MANUFACTURING PROCESSES ARE SUBJECT TO REVIEW/APPROVAL, VERIFICATION AND ANALYSIS BY AUTHORIZED CSI REPRESENTATIVES. ALL CHANGES IN DESIGN, COMPONENTS, PROCESSES OR FABRICATION MUST BE AUTHORIZED, IN WRITING, BY CSI PRIOR TO IMPLEMENTATION. ALL DEVIATIONS FROM DRAWINGS, SPECIFICATIONS OR OTHER REQUIREMENTS MUST BE REPORTED TO CSI FOR APPROVAL PRIOR TO SHIPMENT.

SW

| | | |
|--|--------------------|--|
| | | |
| DRAWN BY: SC | CHECK BY: | ENG. APPR.: S. COOGAN 7/21/05 |
| DATE: 03-29-05 | RELEASE DATE: | Q.A. APPR.: A. KAPLAN 7/25/05 |
| SCALE: NTS | DO NOT SCALE PRINT | MFG. APPR.: B. LEWANDOWSKI 7/21/05 |
| TOLERANCE UNLESS OTHERWISE SPECIFIED: XX: +/- .020 XXX: +/- .005 ANGLES: +/- 1 DEGREE | | CONFIDENTIAL: THIS DOCUMENT CONTAINS CONFIDENTIAL INFORMATION AND MAY NOT BE COPIED OR DIVULGED WITHOUT WRITTEN CONSENT OF CRITICARE SYSTEMS, INC. |
| TITLE: PCB ASSEMBLY (MAIN AND DISPLAY BD) 506N3 | | PART NO.: 90232A001 |
| | | REV. 4 |
| DST: 302 | | SHEET 1 OF 1 |

| REVISIONS | | | |
|-----------|----------|---------------|-----|
| REV. | DATE | DESCRIPTION | BY |
| 1 | 09/01/05 | SEE ECN #8481 | RWK |
| 2 | 10/20/05 | SEE ECN #8544 | RWK |

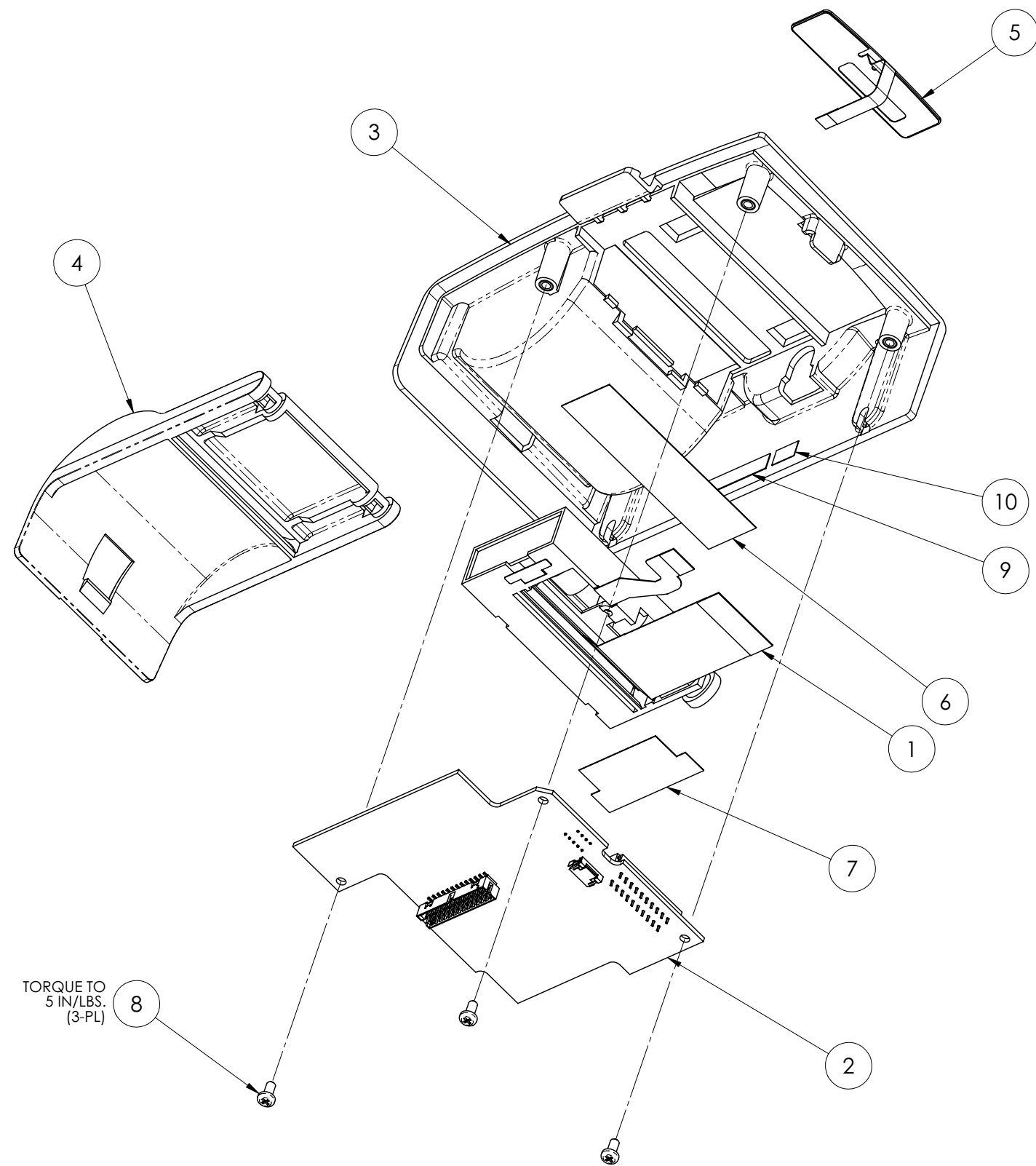

NOTES:

1. CSI RESERVES THE RIGHT TO INSPECT THIS ITEM AT THE VENDORS FACILITY. VENDOR'S INSPECTION SYSTEM AND MANUFACTURING PROCESSES ARE SUBJECT TO REVIEW/APPROVAL, VERIFICATION AND ANALYSIS BY AUTHORIZED CSI REPRESENTATIVES. ALL CHANGES IN DESIGN, COMPONENTS, PROCESSES OR FABRICATION MUST BE AUTHORIZED, IN WRITING, BY CSI PRIOR TO IMPLEMENTATION. ALL DEVIATIONS FROM DRAWINGS, SPECIFICATIONS OR OTHER REQUIREMENTS MUST BE REPORTED TO CSI FOR APPROVAL PRIOR TO SHIPMENT.

SW

| | | | |
|--|--------------------|--|----------|
| | | | |
| DRAWN BY: SC | CHECK BY: | ENG. APPR.: S.COOGAN | 07/25/05 |
| DATE: 03-24-05 | RELEASE DATE: | Q.A. APPR.: A.KAPLAN | 07/25/05 |
| SCALE: NTS | DO NOT SCALE PRINT | MFG. APPR.: LEWANDOWSKI | 07/25/05 |
| TOLERANCE UNLESS OTHERWISE SPECIFIED: XX: +/- .020 XXX: +/- .005 ANGLES: +/- 1 DEGREE | | CONFIDENTIAL: THIS DOCUMENT CONTAINS CONFIDENTIAL INFORMATION AND MAY NOT BE COPIED OR DIVULGED WITHOUT WRITTEN CONSENT OF CRITICARE SYSTEMS, INC. | |
| TITLE: PRINTER ASSEMBLY 506N3 | | PART NO.: 95745A001 | REV. 2 |
| DST: 302 | | SHEET 1 OF 1 | |

| REVISIONS | | | |
|-----------|----------|---------------|-----|
| REV. | DATE | DESCRIPTION | BY |
| 1 | 11/15/05 | SEE ECN #8530 | RWK |
| 2 | 03/08/06 | SEE ECN #8707 | DBL |
| 3 | 09/18/06 | SEE ECN #8955 | RWK |
| 4 | 1/16/07 | SEE ECN #9019 | DBL |

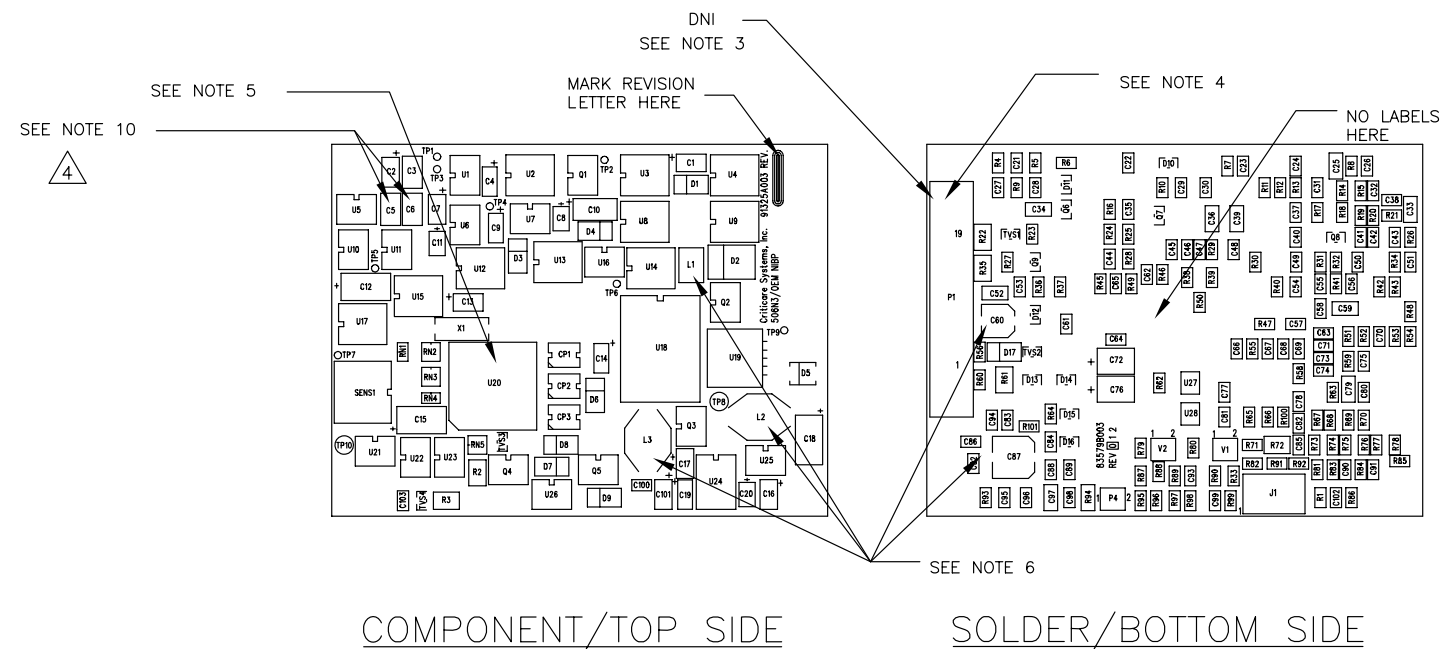

COMPONENT/TOP SIDE

SOLDER/BOTTOM SIDE

NOTES:

- 1.) FINISHED BOARD SHALL MEET CURRENT IPC-A-610 SPECIFICATION, CLASS 2.
 - 2.) APPLIED LABELS MUST BE NON-CONDUCTIVE AND MUST NOT COVER MOUNTING HOLES, VIAS, OR SOLDER JOINTS.
 - 3.) REFER TO BILL OF MATERIAL FOR COMPLETE LISTING OF COMPONENTS NOT INSTALLED (DNI).
 - 4.) DO NOT ALLOW HOLES (20) FOR P1 TO FILL WITH SOLDER.
 - 5.) MICROPROCESSOR MUST BE PROGRAMMED WITH SOFTWARE PRIOR TO TESTING PCB ASSEMBLY.
 - 6.) APPLY RTV AROUND THE BASE OF C60, C87, L1, L2, AND L3.
 - 7.) EACH ASSEMBLY SHALL BE IDENTIFIED WITH THE CSI PART NUMBER AND REVISION FOR THE ASSEMBLY, AND A UNIQUE SERIAL NUMBER IN HUMAN-READABLE FORMAT. SERIAL NUMBERS SHALL NOT BE DUPLICATED. THE FORMAT FOR THE SERIAL NUMBER SHALL CONTAIN AT LEAST 2 ALPHABETICAL PREFIX CHARACTERS THAT ARE RELEVANT TO THE VENDOR TO DISTINGUISH BETWEEN MULTIPLE VENDORS. THE ASSEMBLY PART NUMBER, REVISION AND SERIAL NUMBER SHALL ALSO BE LABELED ON THE PCB ASSEMBLY IN BARCODE FORMAT USING CODE 39 (PREFERRED) OR CODE 128.
 - 8.) CSI RESERVES THE RIGHT TO INSPECT THIS ITEM AT THE VENDORS FACILITY. VENDORS INSPECTION SYSTEM AND MANUFACTURING PROCESS ARE SUBJECT TO REVIEW/APPROVAL, VERIFICATION AND ANALYSIS BY AUTHORIZED CSI REPRESENTATIVES. ALL CHANGES IN DESIGN, COMPONENTS, PROCESSES OR FABRICATION MUST BE AUTHORIZED IN WRITING BY CSI PRIOR TO IMPLEMENTATION. ALL DEVIATIONS FROM DRAWINGS, SPECIFICATIONS, OR OTHER REQUIREMENTS MUST BE REPORTED TO CSI FOR APPROVAL PRIOR TO SHIPMENT. ALL RAW MATERIALS USED TO PRODUCE THIS PART SHALL BE TRACEABLE TO AT LEAST A LOT LEVEL. ALL TRACEABILITY AND INSPECTION RECORDS MUST BE IDENTIFIABLE TO THE RAW MATERIALS, PARTS, ASSEMBLIES, OR DEVICES TO WHICH THEY APPLY AND SHALL BE AVAILABLE UPON REQUEST OR AUDIT BY CSI REPRESENTATIVE.
- FIRST ARTICLES MUST BE INSPECTED AND ACCEPTED BY A CSI QUALITY REPRESENTATIVE PRIOR TO A PRODUCTION SHIPMENT, UNLESS OTHERWISE AUTHORIZED BY CSI. THE FIRST ARTICLES MUST BE INSPECTED AND OR TESTED FOR COMPLIANCE TO THE REQUIREMENT OF APPLICABLE ENGINEERING DRAWINGS AND SPECIFICATIONS. FIRST ARTICLES MUST BE SO MARKED AND IDENTIFIED WITH A PART NUMBER. ANY MAJOR TOOLING, PROCESS, OR COMPONENT CHANGE WILL REQUIRE A NEW FIRST ARTICLE EVALUATION.
- EACH LOT OF PARTS SHALL BE ACCOMPANIED BY A LEGIBLE COPY OF A CERTIFICATE OF COMPLIANCE LISTING THE DRAWING, SPECIFICATION, PROCESS AND APPLICABLE REVISION TO WHICH THE PARTS COMPLY AND BE SIGNED OFF BY THE VENDORS QA REPRESENTATIVE.
- VENDOR SHALL FURNISH A COPY OF ACTUAL INSPECTION/TEST RESULTS ASSOCIATED WITH EACH SERIALIZED ITEM. INSPECTION AND TEST PARAMETERS (OPERATIONAL, MECHANICAL, ELECTRICAL, ENVIRONMENTAL, ETC) SHALL BE DEFINED BY BY CSI MANUFACTURING ENGINEERING.
- 9.) EACH INDIVIDUAL, ASSEMBLED PCB SHALL BE PACKAGED IN CONDUCTIVE, STATIC SHIELDING BAGS OR CONTAINERS AND IDENTIFIED WITH ESD WARNING LABELS.
 - 10.) C5 AND C6 (P/N 20014B002) MUST BE ADDED AS A SECONDARY OPERATION. PCB MUST BE CLEANED OF FLUX AND CONTAMINATES BEFORE APPLYING.

| CRITICARE SYSTEMS, INC. | | | |
|--|--------------------|--|------------|
| DRAWN BY: JEG | CHECK BY: | ENG. APPR.: J.GUPTON | 08/25/05 |
| DATE: 8-23-2005 | RELEASE DATE: | Q.A. APPR.: A.KAPLAN | 08/25/05 |
| SCALE: NONE | DO NOT SCALE PRINT | MFG. APPR.: LEWANDOWSKI | 08/25/05 |
| TOLERANCE UNLESS OTHERWISE SPECIFIED: XX: +/- .020 XXX: +/- .005 ANGLES: +/- 1 DEGREE | | CONFIDENTIAL: THIS DOCUMENT CONTAINS CONFIDENTIAL INFORMATION AND MAY NOT BE COPIED OR DIVULGED WITHOUT WRITTEN CONSENT OF CRITICARE SYSTEMS, INC. | |
| TITLE: 506N3 / OEM NIBP BOARD AY | | PART NO.: 91325A003 | REV.: 4 |
| DIST: -- | | SHEET 1 OF 1 | |

| REV | DATE | ECN # |
|-----|------------|-------|
| 1 | 02/08/2006 | 8707 |

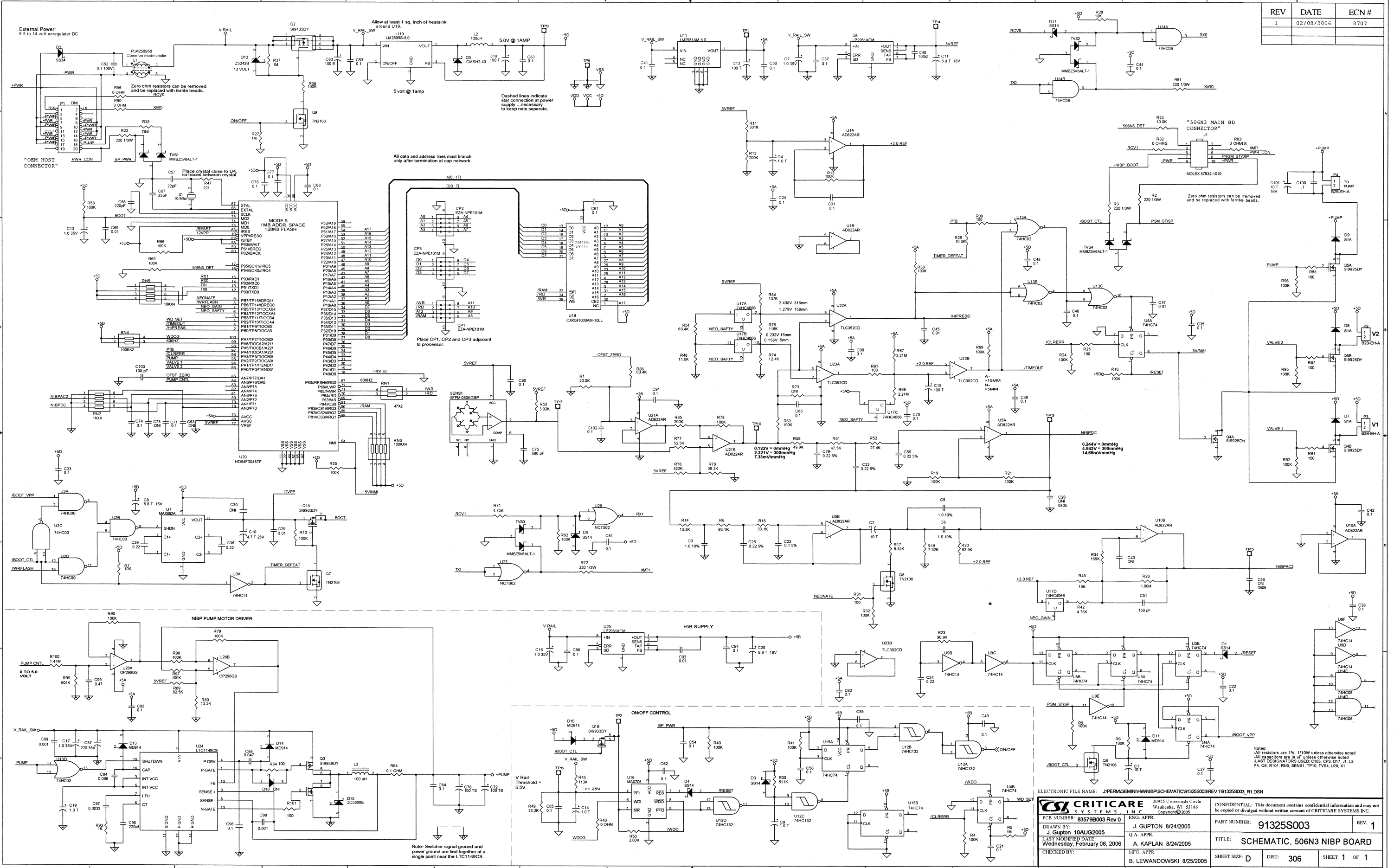

ELECTRONIC FILE NAME: J:\PERFORM\MINI\HW\NIBP\SCHEMATIC\91325S003\REV1\91325S003_R1.DSN

| | | |
|---|-------------------------------------|---|
| CRITICARE SYSTEMS, INC. 20925 Crossroads Circle Waukesha, WI 53186 Copyright © 2005 | | CONFIDENTIAL: This document contains confidential information and may not be copied or divulged without written consent of CRITICARE SYSTEMS INC. |
| PCB NUMBER: 83579B003 Rev 0 | ENG. APPR. J. GUPTON 8/24/2005 | PART NUMBER: 91325S003 |
| DRAWN BY: J. Gupton 10AUG2005 | Q.A. APPR. A. KAPLAN 8/24/2005 | REV: 1 |
| LAST MODIFIED DATE: Wednesday, February 08, 2006 | MEG. APPR. B. LEWANDOWSKI 8/25/2005 | TITLE: SCHEMATIC, 506N3 NIBP BOARD |
| CHECKED BY: | | SHEET SIZE: D DIST: 306 SHEET 1 OF 1 |

| REVISIONS | | | |
|-----------|----------|---------------|-----|
| REV. | DATE | DESCRIPTION | BY |
| 1 | 7/27/05 | SEE ECN #8420 | JEG |
| 2 | 10/26/05 | SEE ECN #8568 | DBL |
| 3 | 06/27/06 | SEE ECN #8685 | JEG |
| 4 | 08/31/06 | SEE ECN #8927 | RWK |
| 5 | 09/18/06 | SEE ECN #8955 | RWK |
| 6 | 9/27/06 | SEE ECN #8980 | DBL |

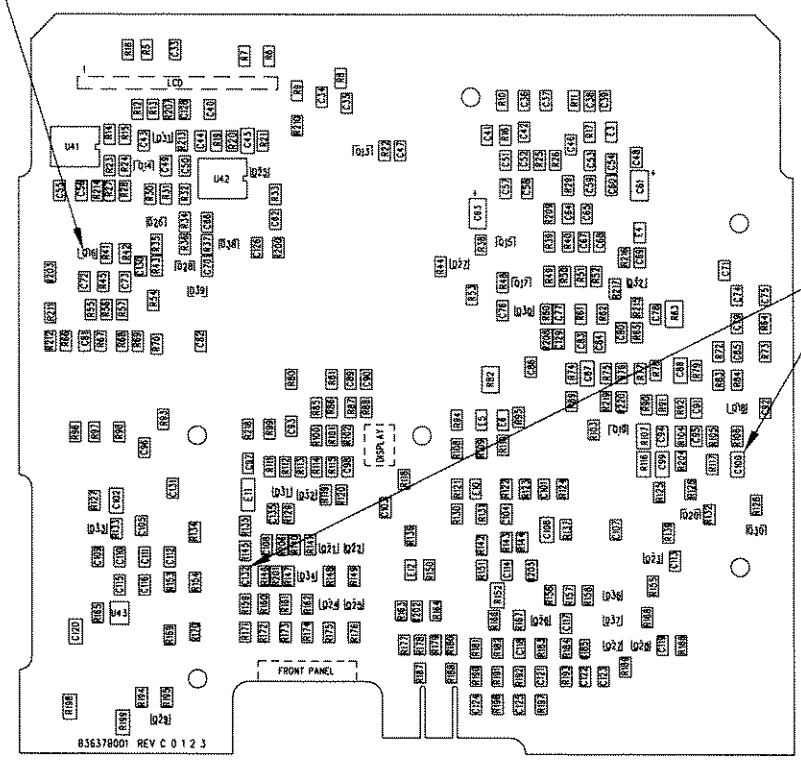
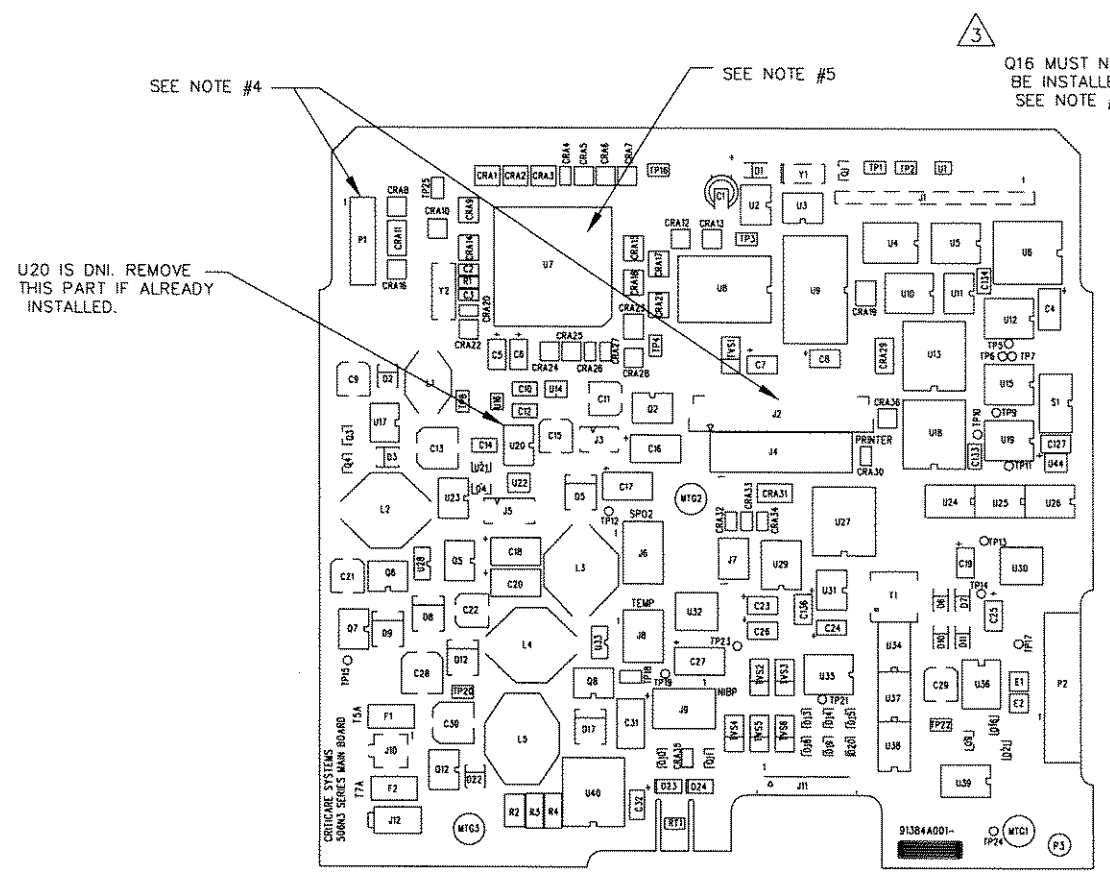

COMPONENT/TOP SIDE

SOLDER/BOTTOM SIDE

NOTES:

- 1.) THIS PCB ASSEMBLY SHALL MEET CURRENT IPC-A-610 STANDARD, CLASS 2.
 - 2.) APPLIED LABELS MUST BE NON-CONDUCTIVE.
 - 3.) PLACE REVISION AND SERIAL NUMBER LABELS ON SOLDER SIDE, NOT COVERING ANY MOUNTING HOLES, VIAS, OR SOLDER JOINTS.
 - 4.) REFER TO BILL OF MATERIAL FOR COMPLETE LISTING OF COMPONENTS NOT INSTALLED (DNI).
 - 5.) MICROPROCESSOR MUST BE PROGRAMMED WITH SOFTWARE PRIOR TO FUNCTIONAL TESTING OF PCB ASSEMBLY.
 - 6.) EACH ASSEMBLY SHALL BE IDENTIFIED WITH THE CSI PART NUMBER AND REVISION FOR THE ASSEMBLY, AND A UNIQUE SERIAL NUMBER IN HUMAN-READABLE FORMAT. SERIAL NUMBERS SHALL NOT BE DUPLICATED. THE FORMAT FOR THE SERIAL NUMBER SHALL CONTAIN AT LEAST 2 ALPHABETICAL PREFIX CHARACTERS THAT ARE RELEVANT TO THE VENDOR TO DISTINGUISH BETWEEN MULTIPLE VENDORS. THE ASSEMBLY PART NUMBER, REVISION AND SERIAL NUMBER SHALL ALSO BE LABELED ON THE PCB ASSEMBLY IN BARCODE FORMAT USING CODE 39 (PREFERRED) OR CODE 128.
 - 7.) CSI RESERVES THE RIGHT TO INSPECT THIS ITEM AT THE VENDORS FACILITY. VENDORS INSPECTION SYSTEM AND MANUFACTURING PROCESS ARE SUBJECT TO REVIEW/APPROVAL, VERIFICATION AND ANALYSIS BY AUTHORIZED CSI REPRESENTATIVES. ALL CHANGES IN DESIGN, COMPONENTS, PROCESSES OR FABRICATION MUST BE AUTHORIZED IN WRITING BY CSI PRIOR TO IMPLEMENTATION. ALL DEVIATIONS FROM DRAWINGS, SPECIFICATIONS, OR OTHER REQUIREMENTS MUST BE REPORTED TO CSI FOR APPROVAL PRIOR TO SHIPMENT. ALL RAW MATERIALS USED TO PRODUCE THIS PART SHALL BE TRACEABLE TO AT LEAST A LOT LEVEL. ALL TRACEABILITY AND INSPECTION RECORDS MUST BE IDENTIFIABLE TO THE RAW MATERIALS, PARTS, ASSEMBLIES, OR DEVICES TO WHICH THEY APPLY AND SHALL BE AVAILABLE UPON REQUEST OR AUDIT BY CSI REPRESENTATIVE.
- FIRST ARTICLES MUST BE INSPECTED AND ACCEPTED BY A CSI QUALITY REPRESENTATIVE PRIOR TO A PRODUCTION SHIPMENT, UNLESS OTHERWISE AUTHORIZED BY CSI. THE FIRST ARTICLES MUST BE INSPECTED AND OR TESTED FOR COMPLIANCE TO THE REQUIREMENT OF APPLICABLE ENGINEERING DRAWINGS AND SPECIFICATIONS. FIRST ARTICLES MUST BE SO MARKED AND IDENTIFIED WITH A PART NUMBER. ANY MAJOR TOOLING, PROCESS, OR COMPONENT CHANGE WILL REQUIRE A NEW FIRST ARTICLE EVALUATION.
- EACH LOT OF PARTS SHALL BE ACCOMPANIED BY A LEGIBLE COPY OF A CERTIFICATE OF COMPLIANCE LISTING THE DRAWING, SPECIFICATION, PROCESS AND APPLICABLE REVISION TO WHICH THE PARTS COMPLY AND BE SIGNED OFF BY THE VENDORS QA REPRESENTATIVE.
- VENDOR SHALL FURNISH A COPY OF ACTUAL INSPECTION/TEST RESULTS ASSOCIATED WITH EACH SERIALIZED ITEM. INSPECTION AND TEST PARAMETERS (OPERATIONAL, MECHANICAL, ELECTRICAL, ENVIRONMENTAL, ETC) SHALL BE DEFINED BY BY CSI MANUFACTURING ENGINEERING.
- 8.) EACH INDIVIDUAL, ASSEMBLED PCB SHALL BE PACKAGED IN CONDUCTIVE, STATIC SHIELDING BAGS OR CONTAINERS AND IDENTIFIED WITH ESD WARNING LABELS.

CRITICARE SYSTEMS, INC.

| | | |
|--|--------------------|--|
| DRAWN BY: JG | CHECK BY: | ENG. APPR.: J. GUPTON 5/5/05 |
| DATE: 10/21/04 | RELEASE DATE: | Q.A. APPR.: M. LARSEN 5/5/05 |
| SCALE: NONE | DO NOT SCALE PRINT | MFG. APPR.: K. HAWVER 5/5/05 |
| TOLERANCE UNLESS OTHERWISE SPECIFIED: XX: +/- .020 XXX: +/- .005 ANGLES: +/- 1 DEGREE | | CONFIDENTIAL: THIS DOCUMENT CONTAINS CONFIDENTIAL INFORMATION AND MAY NOT BE COPIED OR DIVULGED WITHOUT WRITTEN CONSENT OF CRITICARE SYSTEMS, INC. |
| TITLE: 506N3 SERIES MAIN BOARD ASSEMBLY | | PART NO.: 91384A001 |
| | | REV. 6 |
| DIST: -- | | SHEET 1 OF 1 |

| REVISIONS | | | |
|-----------|----------|---------------|-----|
| REV. | DATE | DESCRIPTION | BY |
| 1 | 10/26/05 | SEE ECN #8568 | DBL |
| 2 | 10/28/05 | SEE ECN #8549 | DBL |
| 3 | 11/17/05 | SEE ECN #8607 | JEG |
| 4 | 02/18/06 | SEE ECN #8723 | JEG |
| 5 | 03/30/06 | SEE ECN #8769 | RWK |
| 6 | 08/25/06 | SEE ECN #8927 | RWK |
| 7 | 09/18/06 | SEE ECN #8955 | RWK |
| 8 | 9/27/06 | SEE ECN #8980 | DBL |

SEE NOTE #4

SEE NOTE #5

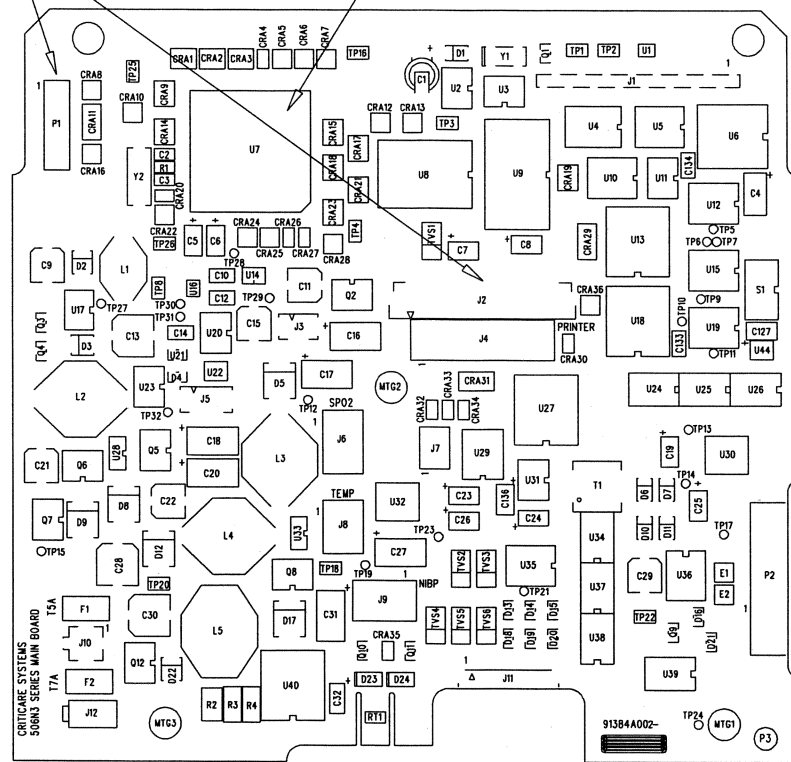

COMPONENT/TOP SIDE

3
C128 MUST NOT BE INSTALLED. SEE NOTE #4.

4
Q16 MUST NOT BE INSTALLED. SEE NOTE #4.

2
INSTALL R224 IN C96 LOCATION.

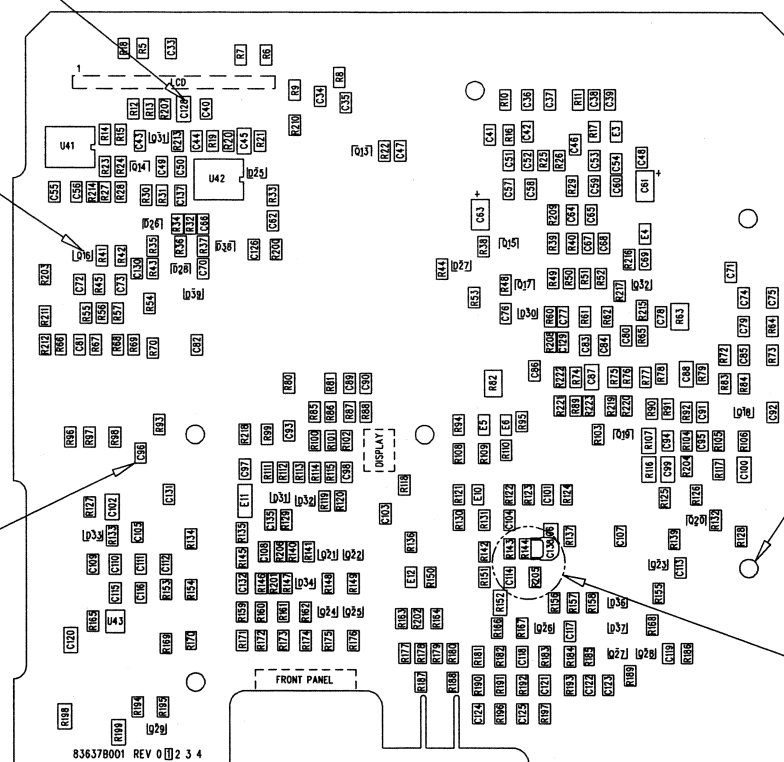

SOLDER/BOTTOM SIDE

PRESS IN STANDOFFS ON THIS SIDE 6 PLCS TYP.

SEE DETAIL A

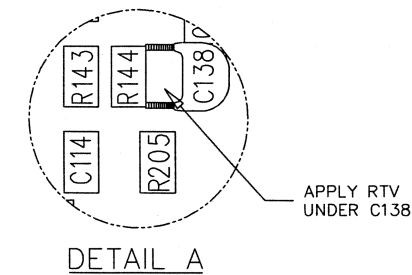

NOTES:

- THIS PCB ASSEMBLY SHALL MEET CURRENT IPC-A-610 SPECIFICATION, CLASS 2.
 - APPLIED LABELS MUST BE NON-CONDUCTIVE.
 - PLACE REVISION AND SERIAL NUMBER LABELS ON SOLDER SIDE, NOT COVERING ANY MOUNTING HOLES, VIAS, OR SOLDER JOINTS.
 - REFER TO BILL OF MATERIAL FOR COMPLETE LISTING OF COMPONENTS NOT INSTALLED (DNI).
 - MICROPROCESSOR MUST BE PROGRAMMED WITH SOFTWARE PRIOR TO FUNCTIONAL TESTING OF PCB ASSEMBLY.
 - EACH ASSEMBLY SHALL BE IDENTIFIED WITH THE CSI PART NUMBER AND REVISION FOR THE ASSEMBLY, AND A UNIQUE SERIAL NUMBER IN HUMAN-READABLE FORMAT. SERIAL NUMBERS SHALL NOT BE DUPLICATED. THE FORMAT FOR THE SERIAL NUMBER SHALL CONTAIN AT LEAST 2 ALPHABETICAL PREFIX CHARACTERS THAT ARE RELEVANT TO THE VENDOR TO DISTINGUISH BETWEEN MULTIPLE VENDORS. THE ASSEMBLY PART NUMBER, REVISION AND SERIAL NUMBER SHALL ALSO BE LABELED ON THE PCB ASSEMBLY IN BARCODE FORMAT USING CODE 39 (PREFERRED) OR CODE 128.
 - CSI RESERVES THE RIGHT TO INSPECT THIS ITEM AT THE VENDORS FACILITY. VENDORS INSPECTION SYSTEM AND MANUFACTURING PROCESS ARE SUBJECT TO REVIEW/APPROVAL, VERIFICATION AND ANALYSIS BY AUTHORIZED CSI REPRESENTATIVES. ALL CHANGES IN DESIGN, COMPONENTS, PROCESSES OR FABRICATION MUST BE AUTHORIZED IN WRITING BY CSI PRIOR TO IMPLEMENTATION. ALL DEVIATIONS FROM DRAWINGS, SPECIFICATIONS, OR OTHER REQUIREMENTS MUST BE REPORTED TO CSI FOR APPROVAL PRIOR TO SHIPMENT. ALL RAW MATERIALS USED TO PRODUCE THIS PART SHALL BE TRACEABLE TO AT LEAST A LOT LEVEL. ALL TRACEABILITY AND INSPECTION RECORDS MUST BE IDENTIFIABLE TO THE RAW MATERIALS, PARTS, ASSEMBLIES, OR DEVICES TO WHICH THEY APPLY AND SHALL BE AVAILABLE UPON REQUEST OR AUDIT BY CSI REPRESENTATIVE.
- FIRST ARTICLES MUST BE INSPECTED AND ACCEPTED BY A CSI QUALITY REPRESENTATIVE PRIOR TO A PRODUCTION SHIPMENT, UNLESS OTHERWISE AUTHORIZED BY CSI. THE FIRST ARTICLES MUST BE INSPECTED AND OR TESTED FOR COMPLIANCE TO THE REQUIREMENT OF APPLICABLE ENGINEERING DRAWINGS AND SPECIFICATIONS. FIRST ARTICLES MUST BE SO MARKED AND IDENTIFIED WITH A PART NUMBER. ANY MAJOR TOOLING, PROCESS, OR COMPONENT CHANGE WILL REQUIRE A NEW FIRST ARTICLE EVALUATION.
- EACH LOT OF PARTS SHALL BE ACCOMPANIED BY A LEGIBLE COPY OF A CERTIFICATE OF COMPLIANCE LISTING THE DRAWING, SPECIFICATION, PROCESS AND APPLICABLE REVISION TO WHICH THE PARTS COMPLY AND BE SIGNED OFF BY THE VENDORS QA REPRESENTATIVE.
- VENDOR SHALL FURNISH A COPY OF ACTUAL INSPECTION/TEST RESULTS ASSOCIATED WITH EACH SERIALIZED ITEM. INSPECTION AND TEST PARAMETERS (OPERATIONAL, MECHANICAL, ELECTRICAL, ENVIRONMENTAL, ETC) SHALL BE DEFINED BY BY CSI MANUFACTURING ENGINEERING.
- EACH INDIVIDUAL, ASSEMBLED PCB SHALL BE PACKAGED IN CONDUCTIVE, STATIC SHIELDING BAGS OR CONTAINERS AND IDENTIFIED WITH ESD WARNING LABELS.

VENDOR SHOULD COMPLY WITH THE FOLLOWING CSI QUALITY REQUIREMENTS: Q1, Q2, Q4, Q5, Q6, Q7, Q10, Q11 AND Q16. IN ADDITION THE QUALITY REQUIREMENTS Q9, Q13 AND Q17 APPLY. SEE CSI WEB SITE (www.csiusa.com/pdf/QA_Requirements.pdf) FOR THE DEFINITION OF THE QUALITY REQUIREMENTS

| DRAWN BY: JG | CHECK BY: | ENG. APPR.: J. GUPTON 9/2/05 |
|--|--|-------------------------------|
| DATE: 8/22/2005 | RELEASE DATE: | Q.A. APPR.: A. KAPLAN 9/12/05 |
| SCALE: NONE | DO NOT SCALE PRINT | MFG. APPR.: K. HAWVER 9/6/05 |
| TOLERANCE UNLESS OTHERWISE SPECIFIED: XX: +/- .020 XXX: +/- .005 ANGLES: +/- 1 DEGREE | CONFIDENTIAL: THIS DOCUMENT CONTAINS CONFIDENTIAL INFORMATION AND MAY NOT BE COPIED OR DIVULGED WITHOUT WRITTEN CONSENT OF CRITICARE SYSTEMS, INC. | |
| TITLE: 506N3 SERIES MAIN BOARD ASSEMBLY | PART NO.: 91384A002 | REV.: 8 |
| DIST: — | SHEET 1 | OF 1 |

| REVISIONS | | | |
|-----------|-----------|----------------|-----|
| REV. | DATE | DESCRIPTION | BY |
| 1 | 2-19-2007 | SEE ECN #91114 | JEG |

SEE NOTE #4

SEE NOTE #5

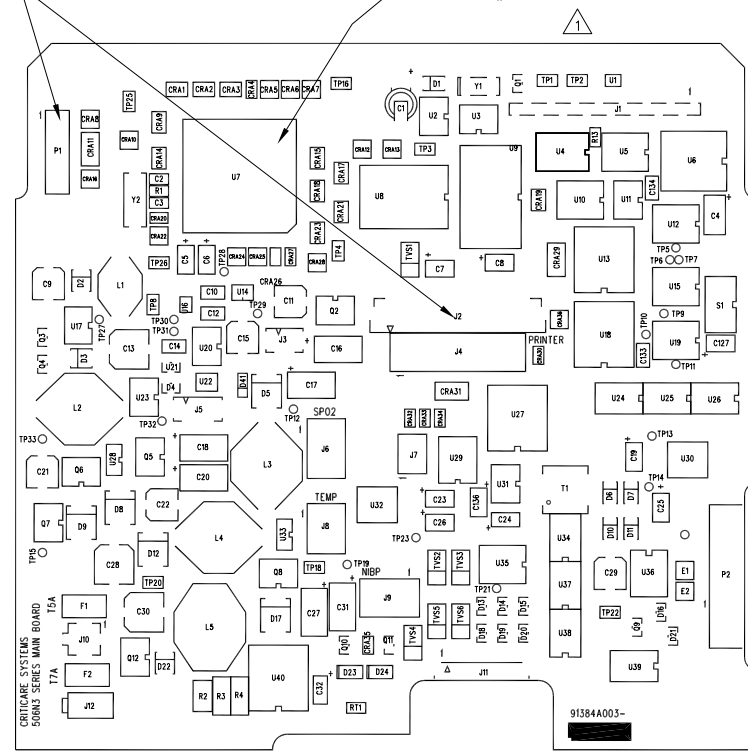

COMPONENT/TOP SIDE

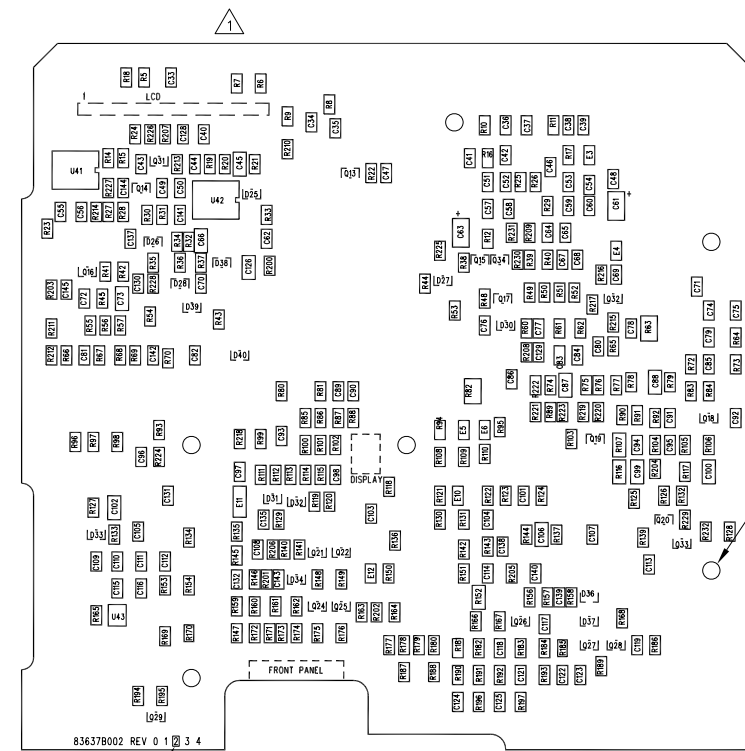

SOLDER/BOTTOM SIDE

FAB REVISION

NOTES:

- THIS PCB ASSEMBLY SHALL MEET CURRENT IPC-A-610 SPECIFICATION, CLASS 2.
- APPLIED LABELS MUST BE NON-CONDUCTIVE.
- PLACE REVISION AND SERIAL NUMBER LABELS ON SOLDER SIDE, NOT COVERING ANY MOUNTING HOLES, VIAS, OR SOLDER JOINTS.
- REFER TO BILL OF MATERIAL FOR COMPLETE LISTING OF COMPONENTS NOT INSTALLED (DNI).
- MICROPROCESSOR MUST BE PROGRAMMED WITH SOFTWARE PRIOR TO FUNCTIONAL TESTING OF PCB ASSEMBLY.
- EACH ASSEMBLY SHALL BE IDENTIFIED WITH THE CSI PART NUMBER AND REVISION FOR THE ASSEMBLY, AND A UNIQUE SERIAL NUMBER IN HUMAN-READABLE FORMAT. SERIAL NUMBERS SHALL NOT BE DUPLICATED. THE FORMAT FOR THE SERIAL NUMBER SHALL CONTAIN AT LEAST 2 ALPHABETICAL PREFIX CHARACTERS THAT ARE RELEVANT TO THE VENDOR TO DISTINGUISH BETWEEN MULTIPLE VENDORS. THE ASSEMBLY PART NUMBER, REVISION AND SERIAL NUMBER SHALL ALSO BE LABELED ON THE PCB ASSEMBLY IN BARCODE FORMAT USING CODE 39 (PREFERRED) OR CODE 128.

FIRST ARTICLES MUST BE INSPECTED AND ACCEPTED BY A CSI QUALITY REPRESENTATIVE PRIOR TO A PRODUCTION SHIPMENT, UNLESS OTHERWISE AUTHORIZED BY CSI. THE FIRST ARTICLES MUST BE INSPECTED AND OR TESTED FOR COMPLIANCE TO THE REQUIREMENT OF APPLICABLE ENGINEERING DRAWINGS AND SPECIFICATIONS. FIRST ARTICLES MUST BE SO MARKED AND IDENTIFIED WITH A PART NUMBER. ANY MAJOR TOOLING, PROCESS, OR COMPONENT CHANGE WILL REQUIRE A NEW FIRST ARTICLE EVALUATION.

EACH LOT OF PARTS SHALL BE ACCOMPANIED BY A LEGIBLE COPY OF A CERTIFICATE OF COMPLIANCE LISTING THE DRAWING, SPECIFICATION, PROCESS AND APPLICABLE REVISION TO WHICH THE PARTS COMPLY AND BE SIGNED OFF BY THE VENDORS QA REPRESENTATIVE.

VENDOR SHALL FURNISH A COPY OF ACTUAL INSPECTION/TEST RESULTS ASSOCIATED WITH EACH SERIALIZED ITEM. INSPECTION AND TEST PARAMETERS (OPERATIONAL, MECHANICAL, ELECTRICAL, ENVIRONMENTAL, ETC) SHALL BE DEFINED BY BY CSI MANUFACTURING ENGINEERING.
- EACH INDIVIDUAL, ASSEMBLED PCB SHALL BE PACKAGED IN CONDUCTIVE, STATIC SHIELDING BAGS OR CONTAINERS AND IDENTIFIED WITH ESD WARNING LABELS.

VENDOR SHOULD COMPLY WITH THE FOLLOWING CSI QUALITY REQUIREMENTS: Q1, Q2, Q4, Q5, Q6, Q7, Q10, Q11 AND Q16. IN ADDITION THE QUALITY REQUIREMENTS Q9, Q13 AND Q17 APPLY. SEE CSI WEB SITE (www.csiusa.com/pdf/QA_Requirements.pdf) FOR THE DEFINITION OF THE QUALITY REQUIREMENTS.

| | | |
|--|--|---------------------------------------|
| CSi CRITICARE SYSTEMS, INC. | | |
| DRAWN BY: JEG | CHECK BY: | ENG. APPR.: J. GUPTON 10/12/2006 |
| DATE: 11OCT06 | RELEASE DATE: | QA APPR.: A. KAPLAN 10/12/2006 |
| SCALE: N/A | DO NOT SCALE PRINT | MFG. APPR.: B. LEWANDOWSKI 10/12/2006 |
| TOLERANCE UNLESS OTHERWISE SPECIFIED: XX: +/- .020 XXX: +/- .005 ANGLES: +/- 1 DEGREE | CONFIDENTIAL: THIS DOCUMENT CONTAINS CONFIDENTIAL INFORMATION AND MAY NOT BE COPIED OR DIVULGED WITHOUT WRITTEN CONSENT OF CRITICARE SYSTEMS, INC. | |
| TITLE: 506N3 SERIES MAIN BOARD | PART NO.: 91384A003 | REV. 1 |
| DST: --- | | SHEET 1 OF 1 |

| REV | DATE | DESCRIPTION |
|-----|---------|---------------|
| 1 | 19JUL05 | SEE ECN #8420 |

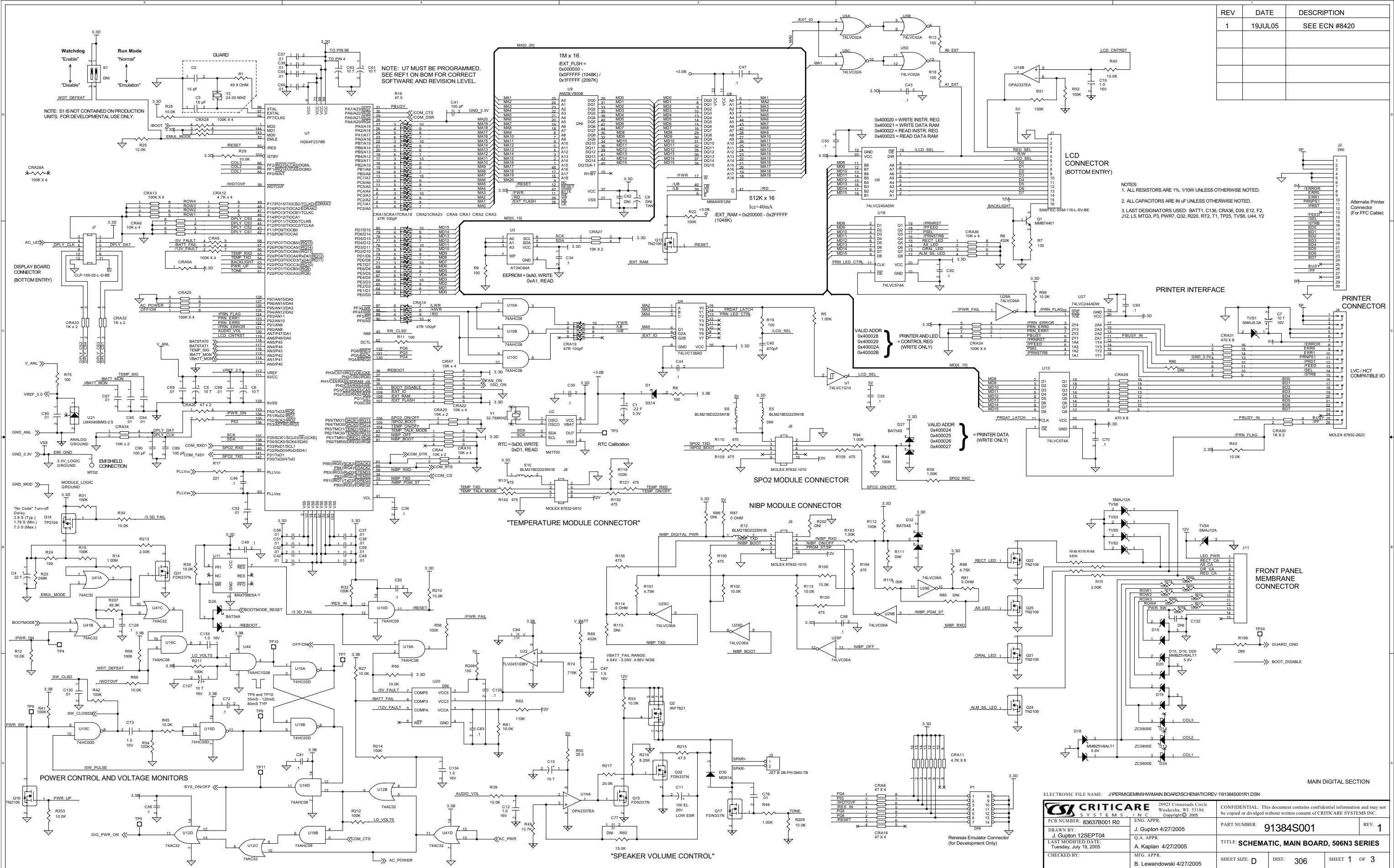

| | | | |
|--|-------------------------------------|---|-----------|
| ELECTRONIC FILE NAME: J:\PERM\GEMINI\HMAIN\BOARDS\SCHEMATIC\REV 191384S001R1.DSN | | CONFIDENTIAL: This document contains confidential information and may not be copied or divulged without written consent of CRITICARE SYSTEMS INC. | |
| PCB NUMBER: 83637B001 RO | ENG. APPR: J. Gupton 4/27/2005 | PART NUMBER: 91384S001 | REV. 1 |
| DRAWN BY: J. Gupton 12SEP04 | Q.A. APPR: A. Kaplan 4/27/2005 | TITLE: SCHEMATIC, MAIN BOARD, 506N3 SERIES | |
| LAST MODIFIED DATE: Tuesday, July 19, 2005 | MFG. APPR: B. Lewandowski 4/27/2005 | SHEET SIZE: D | DIST: 306 |
| CHECKED BY: | | SHEET 1 OF 3 | |

INPUT
12 VDC NOMINAL

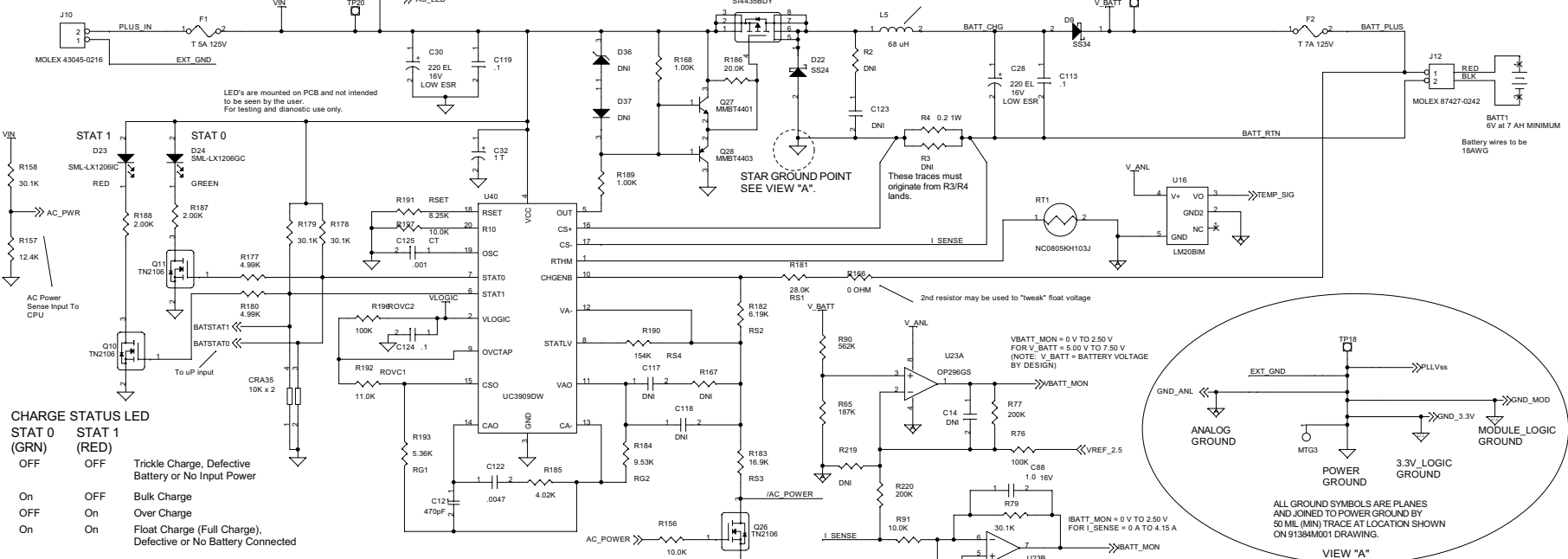

CHARGE STATUS LED

| STAT 0 (GRN) | STAT 1 (RED) | Description |
|--------------|--------------|--|
| OFF | OFF | Trickle Charge, Defective Battery or No Input Power |
| On | OFF | Bulk Charge |
| OFF | On | Over Charge |
| On | On | Floating Charge (Full Charge), Defective or No Battery Connected |

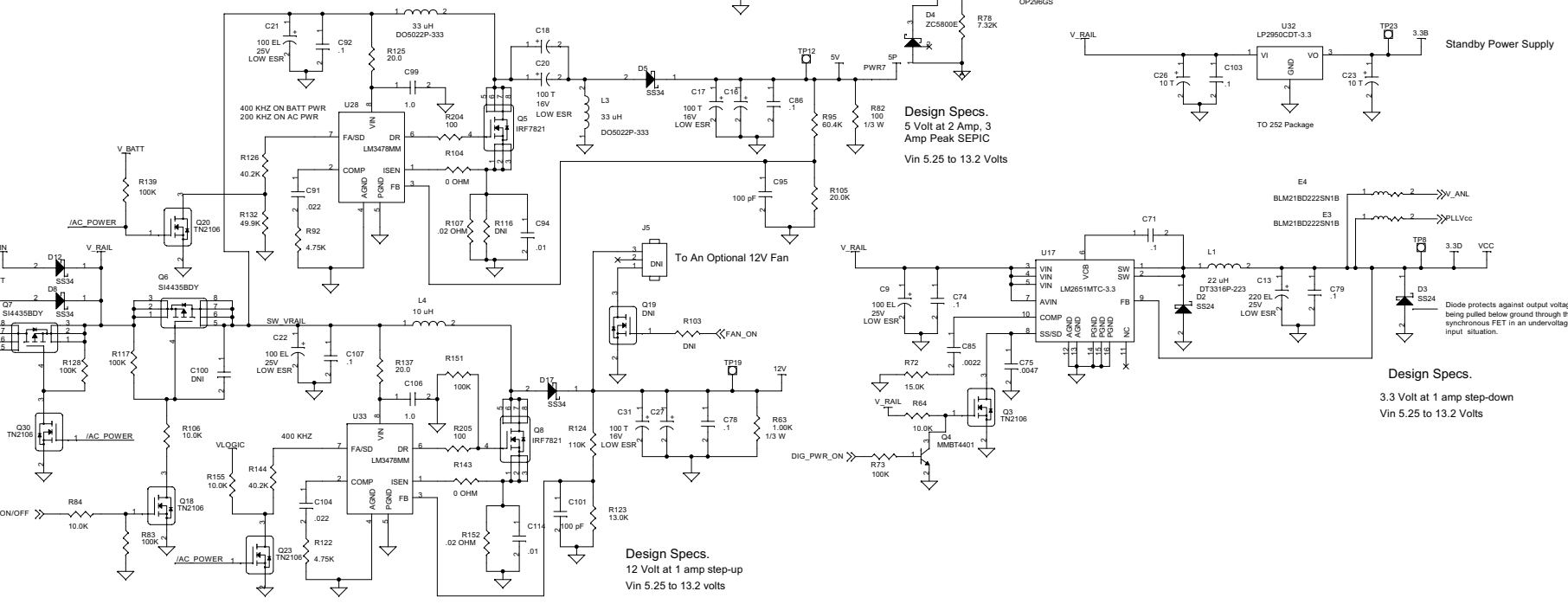
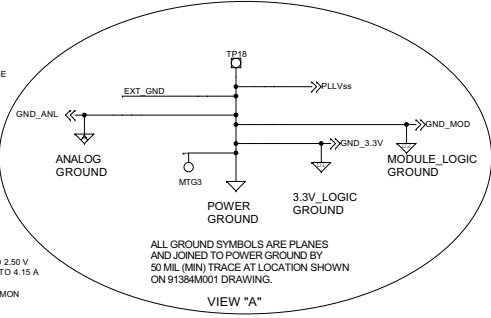

ELECTRONIC FILE NAME: J:\PERM\GEMINI\HW\MAIN BOARD\SCHEMATIC\REV 191384S001R1.DSN

| | | | |
|---|------------|---|--------------|
| CRITICARE 29925 Crossroads Circle Waukesha, WI 53186 Copyright © 2005 | | CONFIDENTIAL: This document contains confidential information and may not be copied or divulged without written consent of CRITICARE SYSTEMS INC. | |
| PCB NUMBER: 83637B001 R0 | ENG. APPR. | PART NUMBER: 91384S001 | REV. 1 |
| DRAWN BY: R. Henning, 23 JUN 04 J. Gupton, 12 SEP 04 | Q.A. APPR. | TITLE: SCHEMATIC, MAIN BOARD, 506N3 SERIES | |
| LAST MODIFIED DATE: Tuesday, July 19, 2005 | MFG. APPR. | SHEET SIZE: D | DIST: 306 |
| CHECKED BY: | | | SHEET 2 OF 3 |

POWER SUPPLY SECTIONS

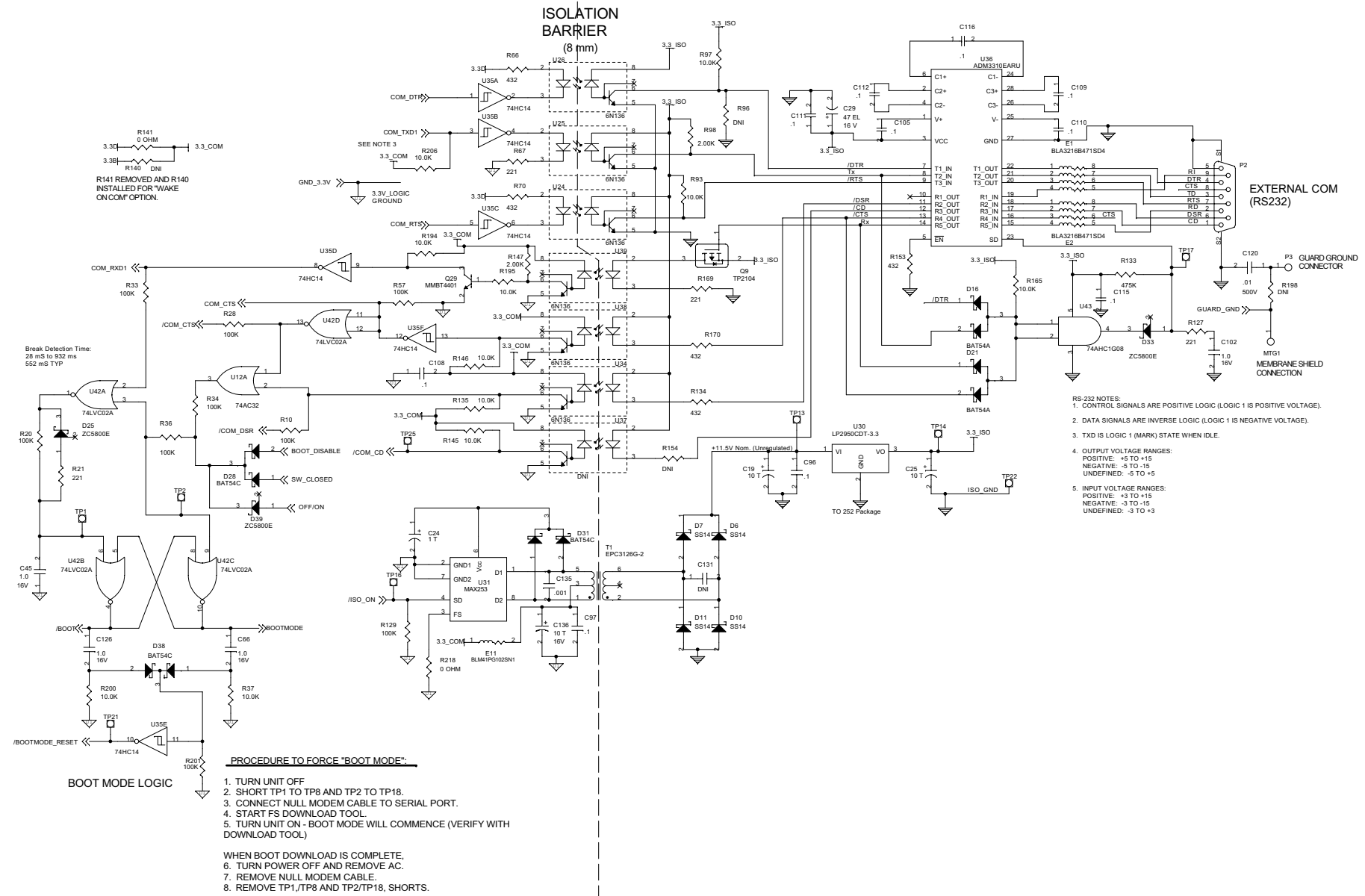

EXTERNAL COM PORT SECTION

ELECTRONIC FILE NAME: J:\PERM\GEMINI\HMAIN\BOARDS\SCHEMATIC\REV 191384S001R1.DSN

| | | | | | |
|--|------------|---|-----------|---|--|
| | | 20925 Crossroads Circle Waukesha, WI 53186 Copyright © 2005 | | CONFIDENTIAL: This document contains confidential information and may not be copied or divulged without written consent of CRITICARE SYSTEMS INC. | |
| PCB NUMBER: 83637B001 R0 | ENG. APPR. | PART NUMBER: 91384S001 | REV. 1 | | |
| DRAWN BY: J. Gupton 12SEPT04 | Q.A. APPR. | TITLE: SCHEMATIC, MAIN BOARD, 506N3 SERIES | | | |
| LAST MODIFIED DATE: Wednesday, July 13, 2005 | MFG. APPR. | SHEET SIZE: D | DIST: 306 | SHEET 3 OF 3 | |

| REV | DATE | DESCRIPTION |
|-----|------------|---------------|
| 1 | 10-20-2005 | SEE ECN #8549 |
| 2 | 11-17-2005 | SEE ECN #8607 |
| 3 | 02-17-2006 | SEE ECN #8723 |
| 4 | 03-20-2006 | SEE ECN #8769 |

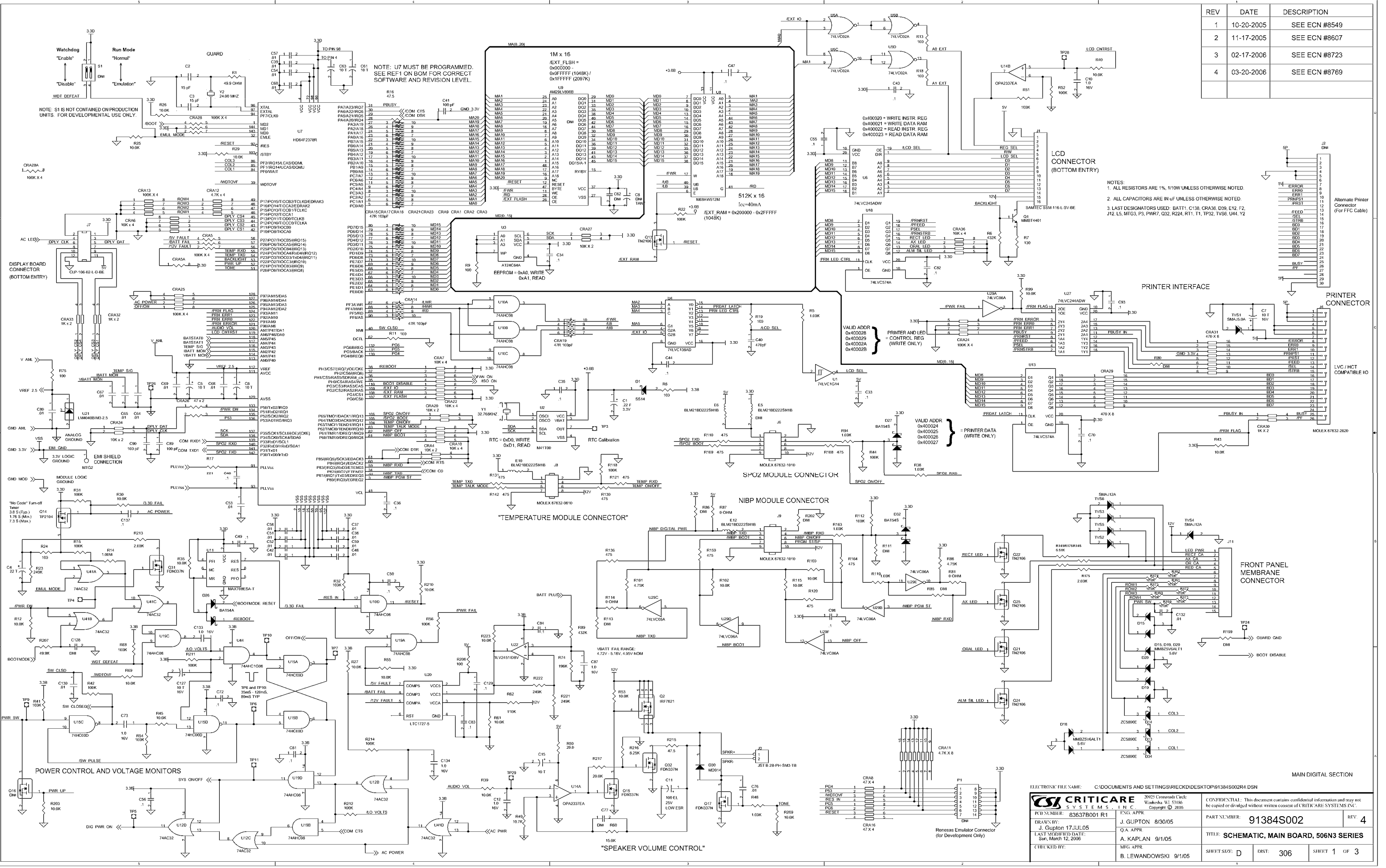

ELECTRONIC FILE NAME: C:\DOCUMENTS AND SETTINGS\RIECKID\DESKTOP\81384S002.RSN

CRITICARE SYSTEMS, INC.
3925 Crossroads Circle
Waukegan, IL 60087
Copyright © 2005

PCB NUMBER: 83637B001 R1
DRAWN BY: J. GUPTON 17JUL05
LAST MODIFIED DATE: Sun, March 12, 2006
CHK BY: MRG APPR B. LEWANDOWSKI 9/1/05

ENG APPR: J. GUPTON 8/30/05
Q.A. APPR: A. KAPLAN 9/1/05
MRG APPR: B. LEWANDOWSKI 9/1/05

CONFIDENTIAL: This document contains confidential information and may not be copied or distributed without written consent of CRITICARE SYSTEMS, INC.

PART NUMBER: 91384S002
TITLE: SCHEMATIC, MAIN BOARD, 506N3 SERIES
SHEET SIZE: D
DST: 306
SHEET 1 OF 3

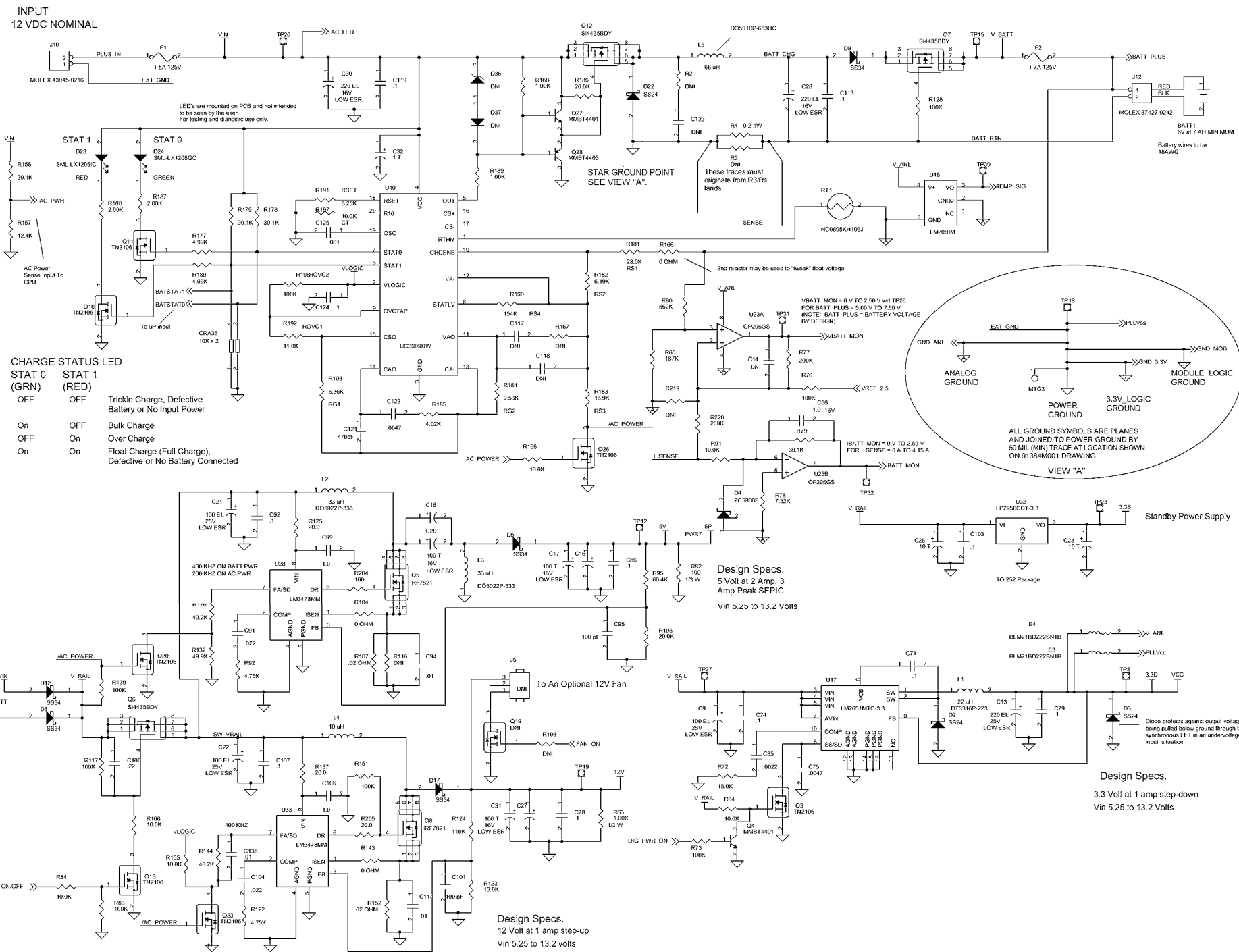

POWER SUPPLY SECTIONS

| | | | |
|---|------------|--|-----------|
| ELECTRONIC FILE NAME: C:\DOCUMENTS AND SETTINGS\RIECKID\DESKTOP\91384S002R4.DSN | | 3925 Crossroads Circle Waukegan, IL 60087 Copyright © 2005 | |
| PCB NUMBER: 83637B001 R1 | ENG APPR: | PART NUMBER: 91384S002 | REV: 4 |
| DRAWN BY: J. Guplon 17JUL05 | Q.A. APPR: | TITLE: SCHEMATIC, MAIN BOARD, 506N3 SERIES | |
| LAST MODIFIED DATE: Sun, March 12, 2006 | MRG APPR: | SHEET SIZE: D | DIST: 306 |
| CHECKED BY: | | SHEET 2 OF 3 | |

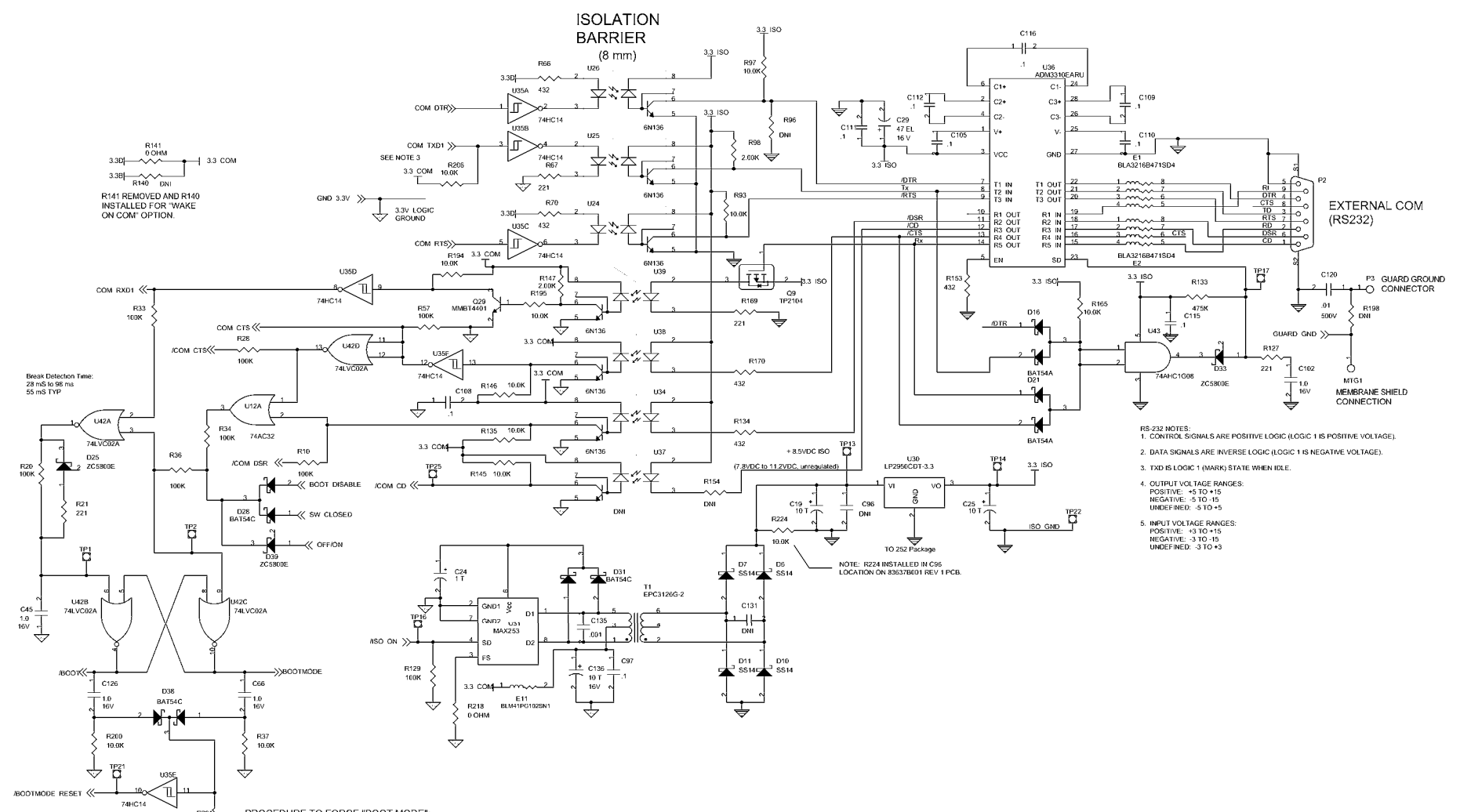

Break Detection Time:
28 ns to 98 ns
55 ns TVP

R141
0 OHM
R140 DNI
3.3 COM
3.3E
R141 REMOVED AND R140
INSTALLED FOR "WAKE
ON COM" OPTION.

ISOLATION
BARRIER
(8 mm)

EXTERNAL COM
(RS232)

- RS 232 NOTES:
- CONTROL SIGNALS ARE POSITIVE LOGIC (LOGIC 1 IS POSITIVE VOLTAGE).
 - DATA SIGNALS ARE INVERSE LOGIC (LOGIC 1 IS NEGATIVE VOLTAGE).
 - TXD IS LOGIC 1 (MARK) STATE WHEN IDLE.
 - OUTPUT VOLTAGE RANGES:
POSITIVE: +5 TO +15
NEGATIVE: -5 TO -15
UNDEFINED: -5 TO +5
 - INPUT VOLTAGE RANGES:
POSITIVE: +3 TO +15
NEGATIVE: -3 TO -15
UNDEFINED: -3 TO +3

BOOT MODE LOGIC

PROCEDURE TO FORCE "BOOT MODE"

1. TURN UNIT OFF AND REMOVE AC.
2. SHORT TP1 TO TP8 AND TP2 TO TP18.
3. CONNECT NULL MODEM CABLE TO SERIAL PORT.
4. START FS DOWNLOAD TOOL.
5. TURN UNIT ON - BOOT MODE WILL COMMENCE (VERIFY WITH DOWNLOAD TOOL.)

WHEN BOOT DOWNLOAD IS COMPLETE,

6. TURN POWER OFF AND REMOVE AC.
7. REMOVE NULL MODEM CABLE.
8. REMOVE TP1/TP8 AND TP2/TP18, SHORTS.

EXTERNAL COM PORT SECTION

| | | | | | |
|---|------------|--|-----------|--|--|
| ELECTRONIC FILE NAME: C:\DOCUMENTS AND SETTINGS\RIECKID\DESKTOP\81384S002R4.DSN | | 2025 Crossroads Circle Waukegan, IL 60086 Copyright © 2005 | | CONFIDENTIAL: This document contains confidential information and may not be copied or distributed without written consent of CRITICARE SYSTEMS INC. | |
| PCB NUMBER: 83637B001 R1 | ENG APPR: | PART NUMBER: 91384S002 | REV: 4 | | |
| DRAWN BY: J. Cupolon 17 JUL 05 | Q.A. APPR: | TITLE: SCHEMATIC, MAIN BOARD, 506N3 SERIES | | | |
| LAST MODIFIED DATE: Sun, March 12, 2006 | MRG APPR: | SHEET SIZE: D | DIST: 306 | SHEET 3 OF 3 | |
| CHECKED BY: | | | | | |

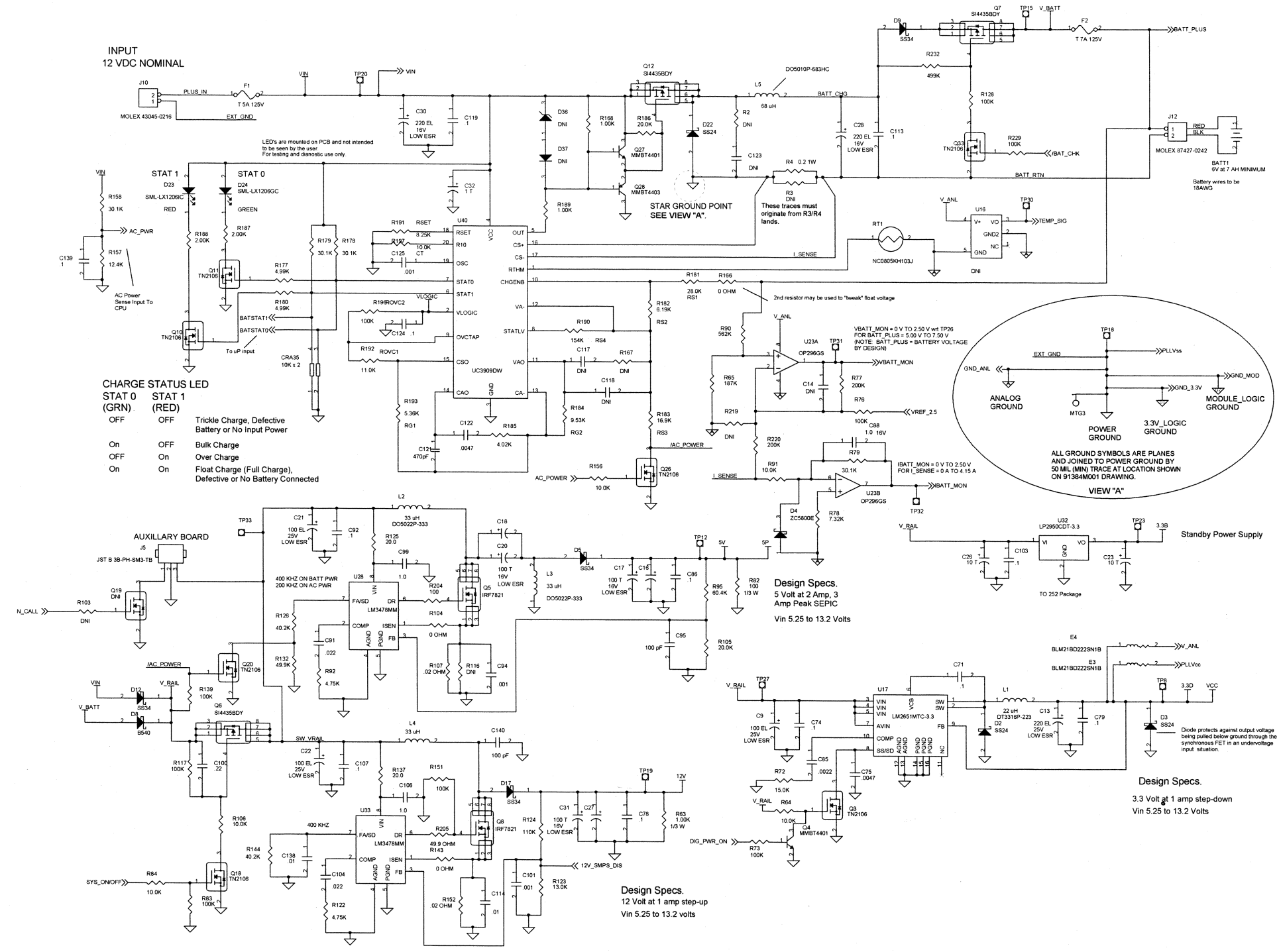

POWER SUPPLY SECTIONS

ELECTRONIC FILE NAME: J:\PERM\GEMINI\HMAIN BOARD\SCHEMATIC\91384S003\REV 09\91384S003R0.DSN

| | | | |
|--|------------|--|--------------|
| PCB NUMBER: 83637B002 R1 | ENG. APPR. | PART NUMBER: 91384S003 | REV. 0 |
| DRAWN BY: J. Gupton 17NOV05 | Q.A. APPR. | TITLE: SCHEMATIC, MAIN BOARD, 506N3 SERIES | |
| LAST MODIFIED DATE: Friday Oct 6, 2006 | MEG. APPR. | SHEET SIZE: D | DIST: 306 |
| CHECKED BY: | | | SHEET 2 OF 3 |

CRITICARE SYSTEMS INC. 20925 Crossroads Circle, Wallingford, WI 53190, Copyright © 2005

CONFIDENTIAL: This document contains confidential information and may not be copied or divulged without written consent of CRITICARE SYSTEMS INC.

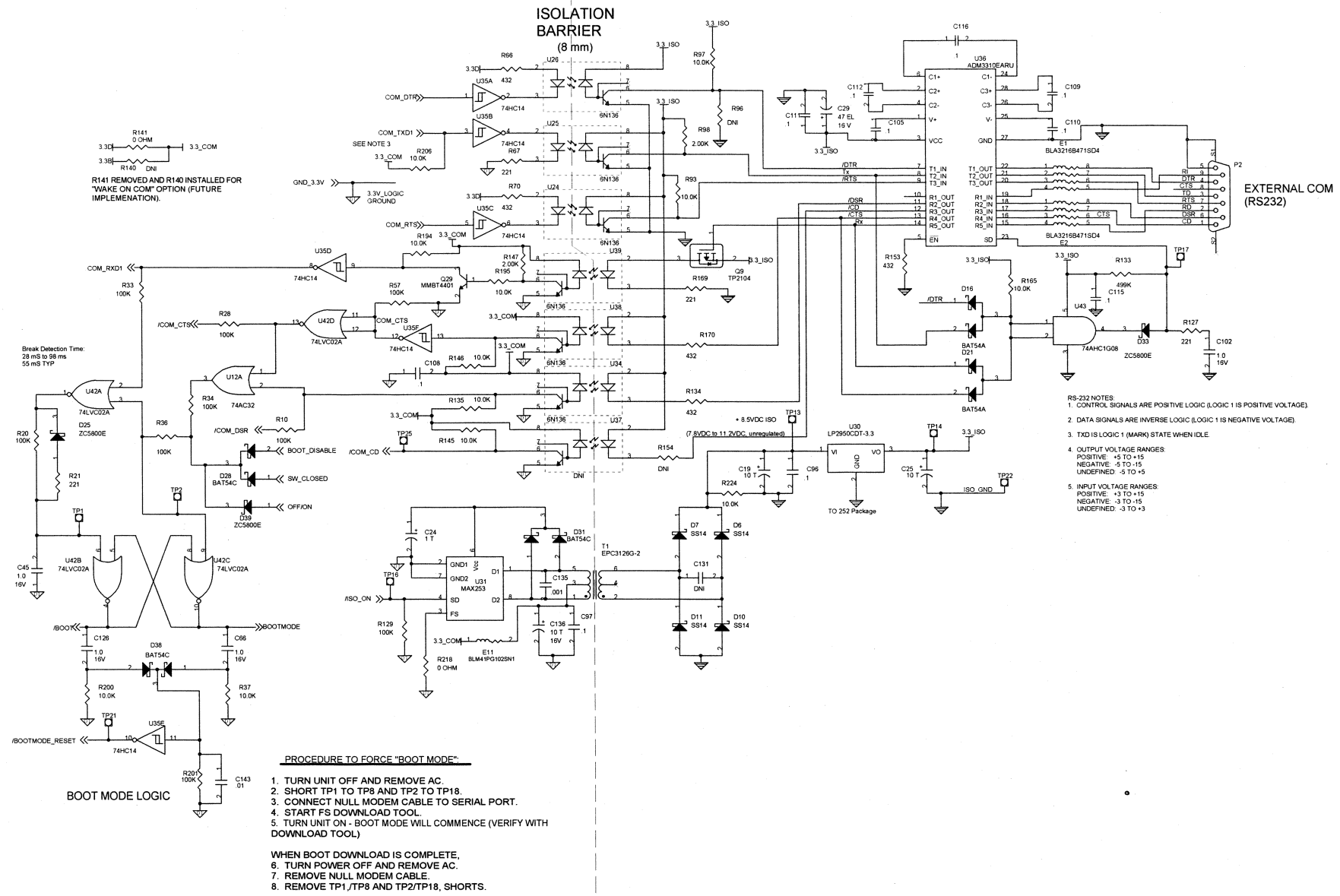

EXTERNAL COM PORT SECTION

ELECTRONIC FILE NAME: J:\PERMIGEMINI\HWMAIN BOARD\SCHEMATIC\91384S003\REV 0\91384S003R0.DSN

| | | | | | |
|--|------------|---|-----------|---|--|
| | | 20925 Crossroads Circle Waukesha, WI 53186 Copyright © 2005 | | CONFIDENTIAL: This document contains confidential information and may not be copied or divulged without written consent of CRITICARE SYSTEMS INC. | |
| PCB NUMBER: 83637B002 R1 | ENG. APPR. | PART NUMBER: 91384S003 | REV: 0 | | |
| DRAWN BY: J. Gupton 17NOV05 | Q.A. APPR. | TITLE: SCHEMATIC, MAIN BOARD, 506N3 SERIES | | | |
| LAST MODIFIED DATE: Friday Oct 6, 2006 | MPG APPR. | SHEET SIZE: D | DIST: 306 | SHEET 3 OF 3 | |

| REVISIONS | | | |
|-----------|----------|---------------|-----|
| REV. | DATE | DESCRIPTION | BY |
| 1 | 06/27/06 | SEE ECN #8903 | JEG |

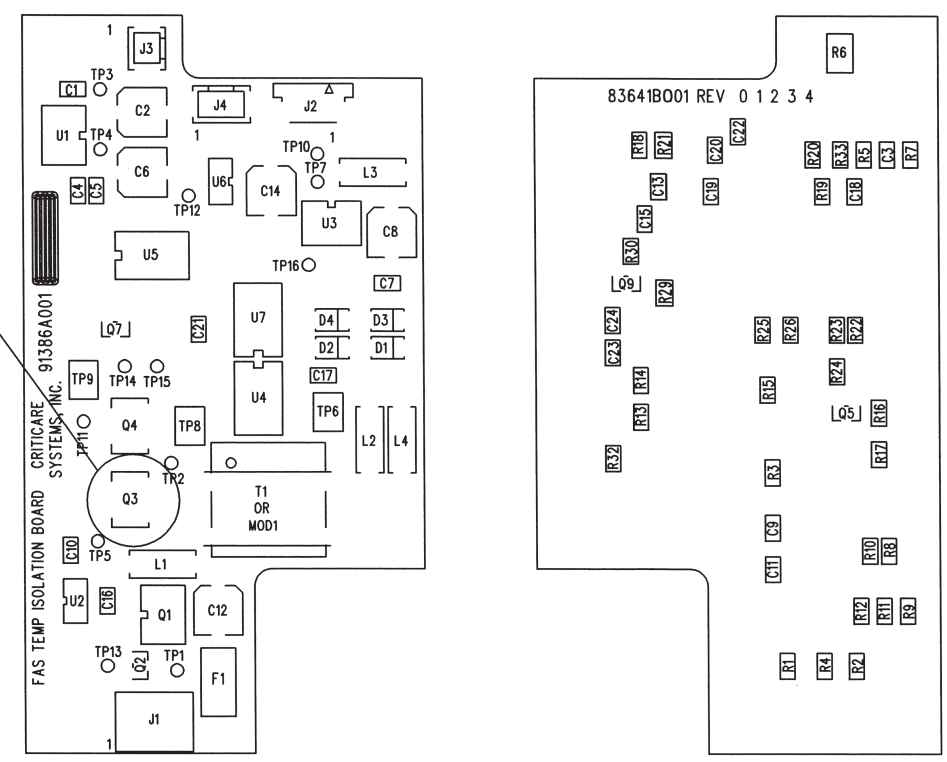
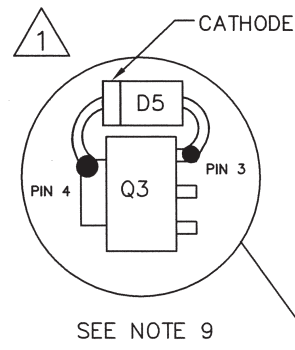

COMPONENT SIDE

SOLDER SIDE

CRITICARE SYSTEMS, INC.

| | | |
|--|------------------------------|--|
| DRAWN BY: RWK | CHECK BY: <i>ECZ 7/28/06</i> | ENG. APPR.: R. HENNING 5/4/05 |
| DATE: 04/25/05 | RELEASE DATE: | Q.A. APPR.: M. LARSEN 5/5/05 |
| SCALE: 1:1 | DO NOT SCALE PRINT | MFG. APPR.: K. HAWVER 5/5/05 |
| TOLERANCE UNLESS OTHERWISE SPECIFIED: XX: +/- .020 XXX: +/- .005 ANGLES: +/- 1 DEGREE | | CONFIDENTIAL: THIS DOCUMENT CONTAINS CONFIDENTIAL INFORMATION AND MAY NOT BE COPIED OR DIVULGED WITHOUT WRITTEN CONSENT OF CRITICARE SYSTEMS, INC. |
| TITLE: FASTEMP ISOLATION ASSEMBLY | | PART NO.: 91386A001 |
| DIST: — | | REV. 1 |
| SHEET 1 OF 1 | | |

NOTES:

- 1.) FINISHED BOARD SHALL MEET CURRENT IPC-A-600/6012 STANDARDS.
- 2.) FINISHED BOARD THICKNESS SHALL BE .062+/- .010.
- 3.) 83641B001 IS USED ON ASSEMBLY 91386A001.
- 4.) BOARD TO BE FABRICATED WITH RAILS OR IN MULTIPLE UP PANELS TO AID AND OPTIMIZE COMPONENT ASSEMBLY. CONTACT CSI'S CONTRACT MANUFACTURER FOR THE PREFERRED LAYOUT. CSI TO APPROVE LAYOUT BEFORE FABRICATION.
- 5.) LABELING MUST BE NON-CONDUCTIVE
- 7.) BOARD ASSEMBLY HOUSE IS TO PROVIDE SERIALIZATION OF EVERY BOARD.
- 8.) CSI RESERVES THE RIGHT TO INSPECT THIS ITEM AT THE VENDORS FACILITY. VENDORS INSPECTION SYSTEM AND MANUFACTURING PROCESS ARE SUBJECT TO REVIEW/APPROVAL, VERIFICATION AND ANALYSIS BY AUTHORIZED CSI REPRESENTATIVES. ALL CHANGES IN DESIGN, COMPONENTS, PROCESSES OR FABRICATION MUST BE AUTHORIZED IN WRITING BY CSI PRIOR TO IMPLEMENTATION. ALL DEVIATIONS FROM DRAWINGS, SPECIFICATIONS, OR OTHER REQUIREMENTS MUST BE REPORTED TO CSI FOR APPROVAL PRIOR TO SHIPMENT. ALL RAW MATERIALS USED TO PRODUCE THIS PART SHALL BE TRACEABLE TO AT LEAST A LOT LEVEL. ALL TRACEABILITY AND INSPECTION RECORDS MUST BE IDENTIFIABLE TO THE RAW MATERIALS, PARTS, ASSEMBLIES, OR DEVICES TO WHICH THEY APPLY AND SHALL BE AVAILABLE UPON REQUEST OR AUDIT BY CSI REPRESENTATIVE.

FIRST ARTICLES MUST BE INSPECTED AND ACCEPTED BY A CSI QUALITY REPRESENTATIVE PRIOR TO A PRODUCTION SHIPMENT, UNLESS OTHERWISE AUTHORIZED BY CSI. THE FIRST ARTICLES MUST BE INSPECTED AND OR TESTED FOR COMPLIANCE TO THE REQUIREMENT OF APPLICABLE ENGINEERING DRAWINGS AND SPECIFICATIONS. FIRST ARTICLES MUST BE SO MARKED AND IDENTIFIED WITH A PART NUMBER. ANY MAJOR TOOLING, PROCESS, OR COMPONENT CHANGE WILL REQUIRE A NEW FIRST ARTICLE EVALUATION.

EACH LOT OF PARTS SHALL BE ACCOMPANIED BY A LEGIBLE COPY OF A CERTIFICATE OF COMPLIANCE LISTING THE DRAWING, SPECIFICATION, PROCESS AND APPLICABLE REVISION TO WHICH THE PARTS COMPLY AND BE SIGNED OFF BY THE VENDORS QA REPRESENTATIVE.

VENDOR SHALL FURNISH A COPY OF ACTUAL INSPECTION/TEST RESULTS ASSOCIATED WITH EACH SERIALIZED ITEM. INSPECTION AND TEST PARAMETERS (OPERATIONAL, MECHANICAL, ELECTRICAL, ENVIRONMENTAL, ETC) SHALL BE DEFINED BY CSI MANUFACTURING ENGINEERING.

EACH ASSEMBLY SHALL BE IDENTIFIED WITH THE CSI PART NUMBER AND REVISION FOR THE ASSEMBLY, AND A UNIQUE SERIAL NUMBER IN HUMAN-READABLE FORMAT. SERIAL NUMBERS SHALL NOT BE DUPLICATED. THE FORMAT FOR THE SERIAL NUMBER SHALL CONTAIN AT LEAST 2 ALPHABETICAL PREFIX CHARACTERS THAT ARE RELEVANT TO THE VENDOR TO DISTINGUISH BETWEEN MULTIPLE VENDORS. THE ASSEMBLY PART NUMBER, REVISION AND SERIAL NUMBER SHALL ALSO BE LABELED ON THE PCB ASSEMBLY IN BARCODE FORMAT USING CODE 39 (PREFERRED) OR CODE 128.

EACH INDIVIDUAL, ASSEMBLED PCB SHALL BE PACKAGED IN CONDUCTIVE, STATIC SHIELDING BAGS OR CONTAINERS AND IDENTIFIED WITH ESD WARNING LABELS.

- 9.) SOLDER 1N5819 DIODE D5, CSI P/N 50022B003 ACROSS Q3 AS SHOWN. MAKE SURE THE DIODE IS LESS THAN .250 INCHES FROM THE PCB SURFACE.

| REV | DATE | ECN # |
|-----|---------|-------|
| 1 | 6/27/06 | 8903 |
| | | |
| | | |
| | | |
| | | |
| | | |

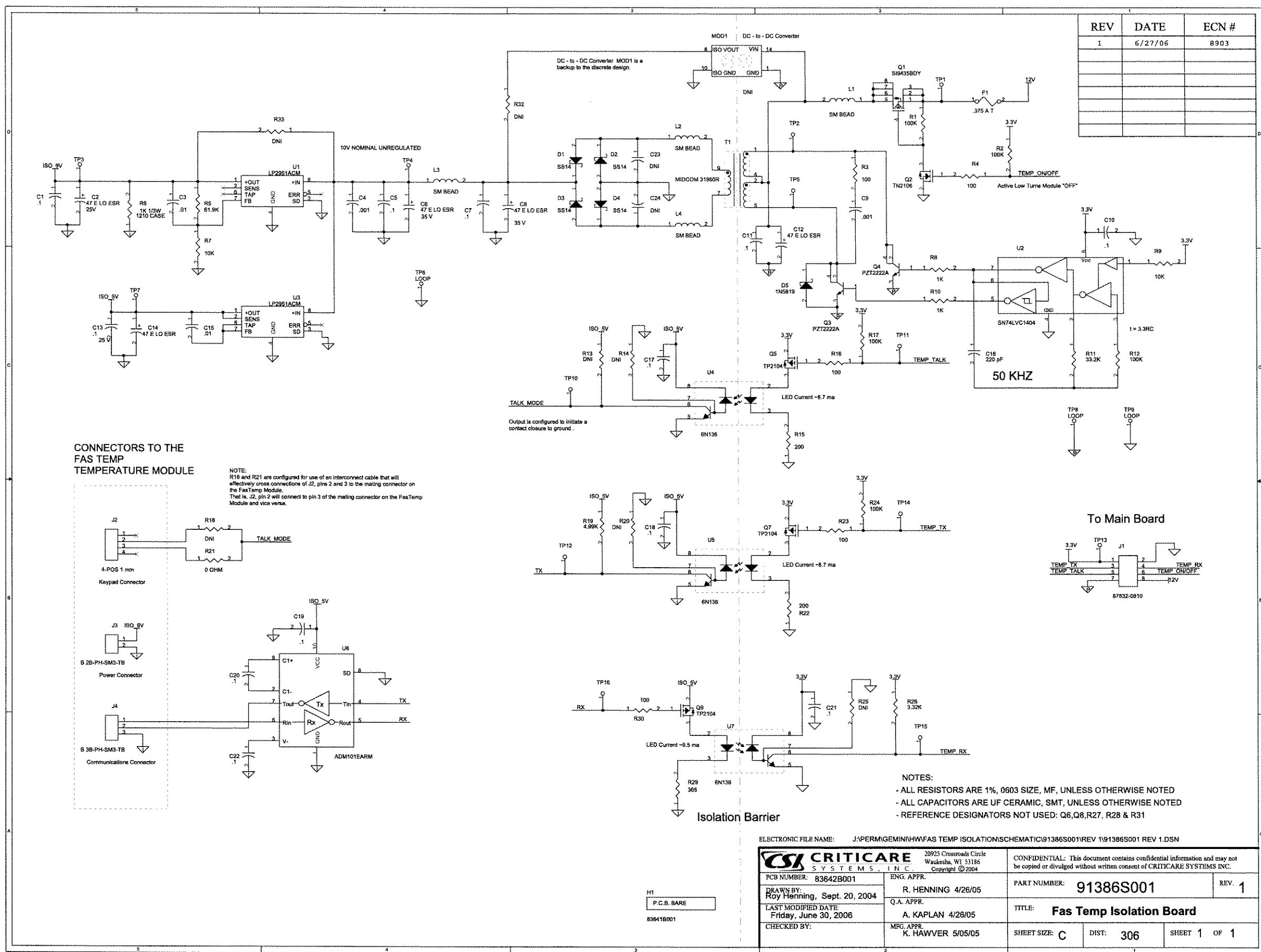

CONNECTORS TO THE FAS TEMP TEMPERATURE MODULE

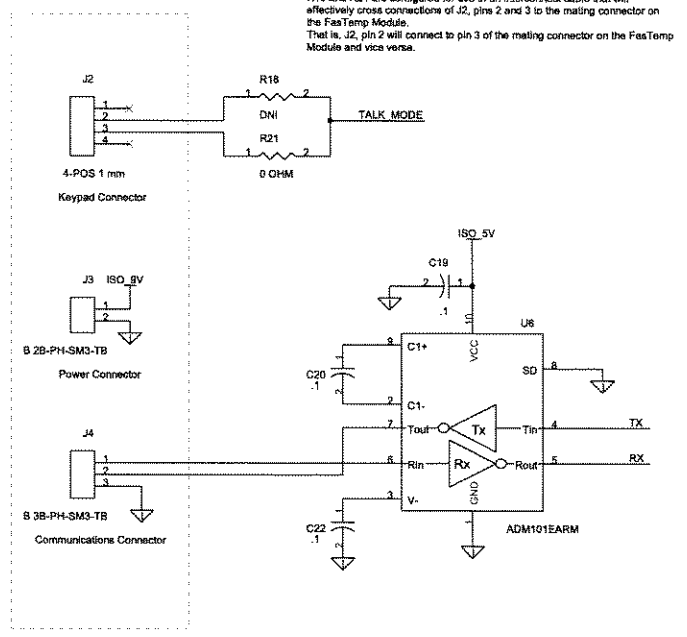

NOTE:
R18 and R21 are configured for use of an interconnect cable that will effectively cross connections of J2, pins 2 and 3 to the mating connector on the FasTemp Module. That is, J2, pin 2 will connect to pin 3 of the mating connector on the FasTemp Module and vice versa.

- NOTES:
- ALL RESISTORS ARE 1%, 0603 SIZE, MF, UNLESS OTHERWISE NOTED
 - ALL CAPACITORS ARE UF CERAMIC, SMT, UNLESS OTHERWISE NOTED
 - REFERENCE DESIGNATORS NOT USED: Q6, Q8, R27, R28 & R31

ELECTRONIC FILE NAME: J:\PERM\GEMINI\HW\FAS TEMP ISOLATION\SCHEMATIC\91386S001\REV 1\91386S001 REV 1.DSN

| | | | |
|---|-------------------------------|---|--------------|
| | | 20925 Crossroads Circle Waukesha, WI 53186 Copyright © 2004 | |
| PCB NUMBER: 83642B001 | ENG. APPR. R. HENNING 4/26/05 | PART NUMBER: 91386S001 | REV. 1 |
| DRAWN BY: Roy Henning, Sept. 20, 2004 | Q.A. APPR. A. KAPLAN 4/26/05 | TITLE: FasTemp Isolation Board | |
| LAST MODIFIED DATE: Friday, June 30, 2006 | MFG. APPR. K. HAWVER 5/05/05 | SHEET SIZE: C | DIST: 306 |
| CHECKED BY: | | | SHEET 1 OF 1 |

H1
P.C.B. BARE
836418001

| REVISIONS | | | |
|-----------|----------|---------------|-----|
| REV. | DATE | DESCRIPTION | BY |
| 1 | 8/2/05 | SEE ECN #8434 | DBL |
| 2 | 02/15/06 | SEE ECN #8648 | RWK |

SEE NOTE 9

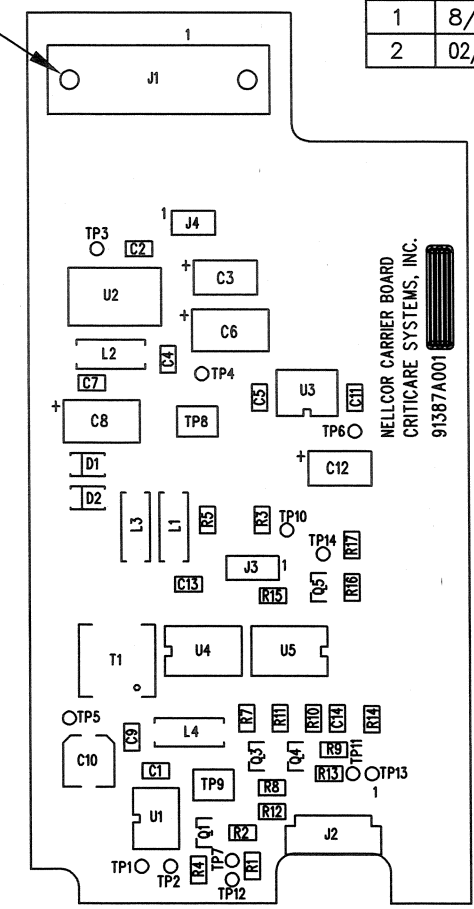

TOP SIDE

NOTES:

- 1.) FINISHED BOARD SHALL MEET CURRENT IPC-A-600/6012 STANDARDS.
- 2.) FINISHED BOARD THICKNESS SHALL BE .062+/- .010.
- 3.) BARE BOARD 83642B001 TO BE USED ON ASSEMBLY 91387A001.
- 4.) BOARD TO BE FABRICATED WITH RAILS OR IN MULTIPLE UP PANELS TO AID AND OPTIMIZE COMPONENT ASSEMBLY. CONTACT CSI'S CONTRACT MANUFACTURER FOR THE PREFERRED LAYOUT. CSI TO APPROVE LAYOUT BEFORE FABRICATION.
- 5.) LABELING MUST BE NON-CONDUCTIVE

1) 6.) EACH ASSEMBLY SHALL BE IDENTIFIED WITH THE CSI PART NUMBER AND REVISION FOR THE ASSEMBLY, AND UNIQUE SERIAL NUMBER IN HUMAN-READABLE FORMAT. SERIAL NUMBERS SHALL NOT BE DUPLICATED. THE FORMAT FOR THE SERIAL NUMBER SHALL CONTAIN AT LEAST 2 ALPHABETICAL PREFIX CHARACTERS THAT ARE RELEVANT TO THE VENDOR TO DISTINGUISH BETWEEN MULTIPLE VENDORS. THE ASSEMBLY PART NUMBER, REVISION AND SERIAL NUMBER SHALL ALSO BE LABELED ON THE PCB ASSEMBLY IN BARCODE FORMAT USING CODE 39 (PREFERRED) OR CODE 128.

1) 7.) CSI RESERVES THE RIGHT TO INSPECT THIS ITEM AT THE VENDOR'S FACILITY. VENDORS INSPECTION SYSTEM AND MANUFACTURING PROCESS ARE SUBJECT TO REVIEW/APPROVAL, VERIFICATION AND ANALYSIS BY AUTHORIZED CSI REPRESENTATIVES. ALL CHANGES IN DESIGN, COMPONENTS, PROCESSES OR FABRICATION MUST BE AUTHORIZED IN WRITING BY CSI PRIOR TO IMPLEMENTATION. ALL DEVIATIONS FROM DRAWINGS, SPECIFICATIONS, OR OTHER REQUIREMENTS MUST BE REPORTED TO CSI FOR APPROVAL PRIOR TO SHIPMENT. ALL RAW MATERIALS USED TO PRODUCE THIS PART SHALL BE TRACEABLE TO AT LEAST A LOT LEVEL.

ALL TRACEABILITY AND INSPECTION RECORDS MUST BE IDENTIFIABLE TO THE RAW MATERIALS, PARTS, ASSEMBLIES, OR DEVICES TO WHICH THEY APPLY AND SHALL BE AVAILABLE UPON REQUEST OR AUDIT BY CSI REPRESENTATIVE.

FIRST ARTICLES MUST BE INSPECTED AND ACCEPTED BY A CSI QUALITY REPRESENTATIVE PRIOR TO A PRODUCTION SHIPMENT, UNLESS OTHERWISE AUTHORIZED BY CSI. THE FIRST ARTICLES MUST BE INSPECTED AND OR TESTED FOR COMPLIANCE TO THE REQUIREMENT OF APPLICABLE ENGINEERING DRAWINGS AND SPECIFICATIONS. FIRST ARTICLES MUST BE SO MARKED AND IDENTIFIED WITH A PART NUMBER. ANY MAJOR TOOLING, PROCESS, OR COMPONENT CHANGE WILL REQUIRE A NEW FIRST ARTICLE EVALUATION.

EACH LOT OF PARTS SHALL BE ACCOMPANIED BY A LEGIBLE COPY OF A CERTIFICATE OF COMPLIANCE LISTING THE DRAWING, SPECIFICATION, PROCESS AND APPLICABLE REVISION TO WHICH THE PARTS COMPLY AND BE SIGNED OFF BY THE VENDORS QA REPRESENTATIVE.

VENDOR SHALL FURNISH A COPY OF ACTUAL INSPECTION/TEST RESULTS ASSOCIATED WITH EACH SERIALIZED ITEM. INSPECTION AND TEST PARAMETERS (OPERATIONAL, MECHANICAL, ELECTRICAL, ENVIRONMENTAL, ETC) SHALL BE DEFINED BY CSI MANUFACTURING ENGINEERING.

1) 8.) EACH INDIVIDUAL, ASSEMBLED PCB SHALL BE PACKAGED IN CONDUCTIVE, STATIC SHIELDING BAGS OR CONTAINERS AND IDENTIFIED WITH ESD WARNING LABELS.

2) 9.) ADD PN: 42653B004, ITEM 1, QTY 2 INTO DB-9 CONNECTOR HOLES FROM BOTTOM SIDE OF PCB. ADD A DROP OF LOCTITE (ITEM 2) TO SCREW THREAD AND TORQUE TO 5 IN. LBS. INSTALL PRIOR TO WAVE SOLDER.

VENDOR SHOULD COMPLY WITH THE FOLLOWING CSI QUALITY REQUIREMENTS: Q1, Q2, Q4, Q5, Q6, Q7, Q10, Q11 AND Q16. IN ADDITION THE QUALITY REQUIREMENTS Q9, Q13 AND Q17 APPLY. SEE CSI WEB SITE (www.csiusa.com/pdf/QA_Requirements.pdf) FOR THE DEFINITION OF THE QUALITY REQUIREMENTS

| | | | |
|--|------------------------------|--|--------|
| CSI CRITICARE SYSTEMS, INC. | | | |
| DRAWN BY: DBL | CHECK BY: <i>ECI 2/20/06</i> | ENG. APPR.: R.HENNING | 4/1/05 |
| DATE: 10/25/04 | RELEASE DATE: | Q.A. APPR.: A.KAPLAN | 4/1/05 |
| SCALE: 1:1 | DO NOT SCALE PRINT | MFG. APPR.: LEWANDOWSKI | 4/1/05 |
| TOLERANCE UNLESS OTHERWISE SPECIFIED: XX: +/- .020 XXX: +/- .005 ANGLES: +/- 1 DEGREE | | CONFIDENTIAL: THIS DOCUMENT CONTAINS CONFIDENTIAL INFORMATION AND MAY NOT BE COPIED OR DIVULGED WITHOUT WRITTEN CONSENT OF CRITICARE SYSTEMS, INC. | |
| TITLE: NELLCOR CARRIER BOARD ASSEMBLY | | PART NO.: 91387A001 | REV. 2 |
| DIST: — | | SHEET 1 OF 1 | |

| REV | DATE | ECN # |
|-----|-----------|---------------|
| 1 | 7/29/2005 | SEE ECN #8434 |
| | | |
| | | |
| | | |
| | | |
| | | |

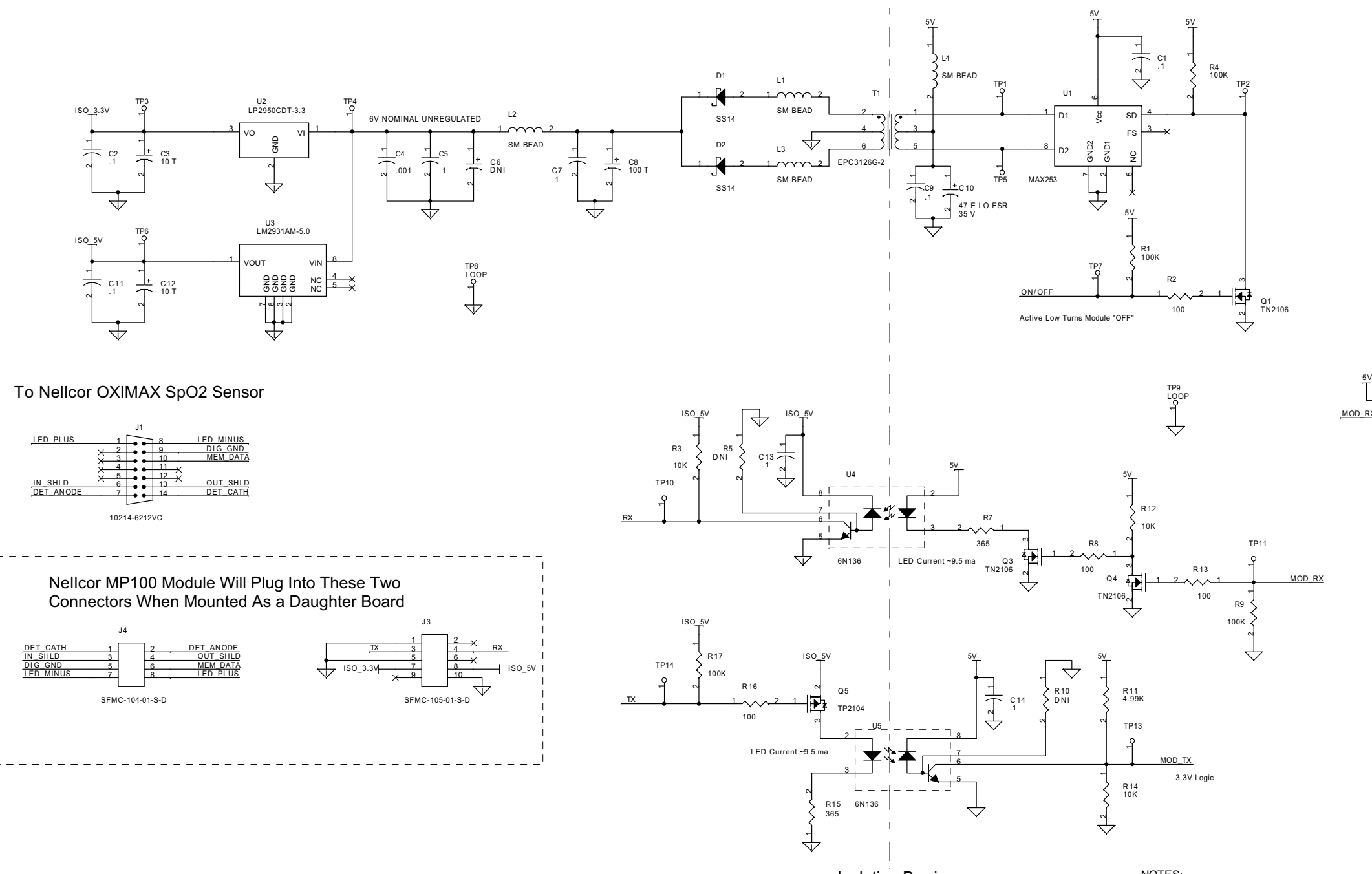

To Nellcor OXIMAX SpO2 Sensor

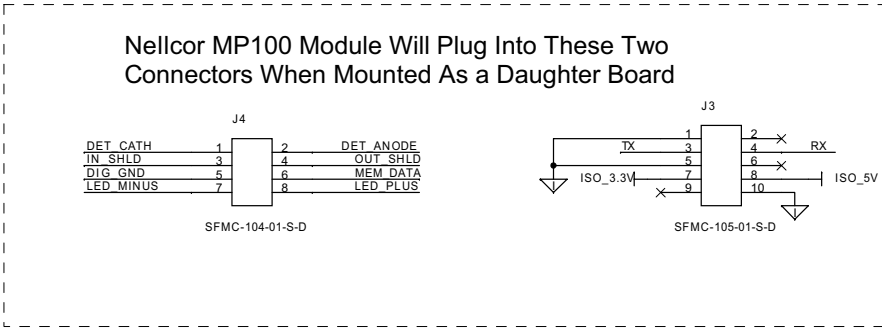
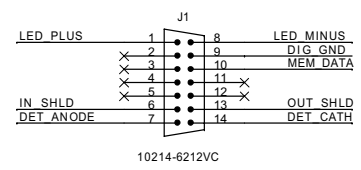

To Main Board

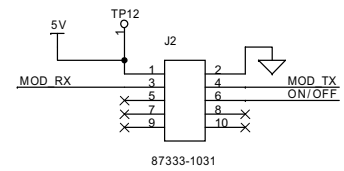

Isolation Barrier

- NOTES:
- ALL RESISTORS ARE 1%, 0603 SIZE, MF, UNLESS OTHERWISE NOTED
 - ALL CAPACITORS ARE UF CERAMIC, SMT, UNLESS OTHERWISE NOTED
 - REFERENCE DESIGNATORS NOT USED: R6,Q2

ELECTRONIC FILE NAME: J:\PERMGEMINI\H\NELLCOR CARRIER\SCHEMATIC\REV 1\91387S001 REV 1.DSN

| | | | | | |
|---|--|---|--|---|--|
| | | 20925 Crossroads Circle Waukesha, WI 53186 Copyright © 2004 | | CONFIDENTIAL: This document contains confidential information and may not be copied or divulged without written consent of CRITICARE SYSTEMS INC. | |
| PCB NUMBER: 83642B001 R1 | | ENG. APPR. R. Henning 4/20/05 | | PART NUMBER: 91387S001 | |
| DRAWN BY: Roy Henning, August 27, 2004 | | Q.A. APPR. A. Kaplan 4/21/05 | | TITLE: Nellcor Carrier Board | |
| LAST MODIFIED DATE: Monday, April 04, 2005 | | MFG. APPR. B. Lewandowski 4/22/05 | | SHEET SIZE: C | |
| CHECKED BY: | | DIST: 306 | | SHEET 1 OF 1 | |

H1
P.C.B. BARE
83642B001

NOTES:

- 1.) FINISHED BOARD SHALL MEET CURRENT IPC-A-600/6012 STANDARDS.
- 2.) FINISHED BOARD THICKNESS SHALL BE .062+/- .010.
- 3.) BARE BOARD 83643B001 TO BE USED ON ASSEMBLY 91388A001.
- 4.) BOARD TO BE FABRICATED WITH RAILS OR IN MULTIPLE UP PANELS TO AID AND OPTIMIZE COMPONENT ASSEMBLY. CONTACT CSI'S CONTRACT MANUFACTURER FOR THE PREFERRED LAYOUT. CSI TO APPROVE LAYOUT BEFORE FABRICATION.
- 5.) LABELING MUST BE NON-CONDUCTIVE
- 6.) BOARD ASSEMBLY HOUSE IS TO PROVIDE SERIALIZATION OF EVERY BOARD.
- 7.) CSI RESERVES THE RIGHT TO INSPECT THIS ITEM AT THE VENDORS FACILITY. VENDORS INSPECTION SYSTEM AND MANUFACTURING PROCESS ARE SUBJECT TO REVIEW/APPROVAL, VERIFICATION AND ANALYSIS BY AUTHORIZED CSI REPRESENTATIVES. ALL CHANGES IN DESIGN, COMPONENTS, PROCESSES OR FABRICATION MUST BE AUTHORIZED IN WRITING BY CSI PRIOR TO IMPLEMENTATION. ALL DEVIATIONS FROM DRAWINGS, SPECIFICATIONS, OR OTHER REQUIREMENTS MUST BE REPORTED TO CSI FOR APPROVAL PRIOR TO SHIPMENT. ALL RAW MATERIALS USED TO PRODUCE THIS PART SHALL BE TRACEABLE TO AT LEAST A LOT LEVEL. ALL TRACEABILITY AND INSPECTION RECORDS MUST BE IDENTIFIABLE TO THE RAW MATERIALS, PARTS, ASSEMBLIES, OR DEVICES TO WHICH THEY APPLY AND SHALL BE AVAILABLE UPON REQUEST OR AUDIT BY CSI REPRESENTATIVE.

FIRST ARTICLES MUST BE INSPECTED AND ACCEPTED BY A CSI QUALITY REPRESENTATIVE PRIOR TO A PRODUCTION SHIPMENT, UNLESS OTHERWISE AUTHORIZED BY CSI. THE FIRST ARTICLES MUST BE INSPECTED AND OR TESTED FOR COMPLIANCE TO THE REQUIREMENT OF APPLICABLE ENGINEERING DRAWINGS AND SPECIFICATIONS. FIRST ARTICLES MUST BE SO MARKED AND IDENTIFIED WITH A PART NUMBER. ANY MAJOR TOOLING, PROCESS, OR COMPONENT CHANGE WILL REQUIRE A NEW FIRST ARTICLE EVALUATION.

EACH LOT OF PARTS SHALL BE ACCOMPANIED BY A LEGIBLE COPY OF A CERTIFICATE OF COMPLIANCE LISTING THE DRAWING, SPECIFICATION, PROCESS AND APPLICABLE REVISION TO WHICH THE PARTS COMPLY AND BE SIGNED OFF BY THE VENDORS QA REPRESENTATIVE.

VENDOR SHALL FURNISH A COPY OF ACTUAL INSPECTION/TEST RESULTS ASSOCIATED WITH EACH SERIALIZED ITEM. INSPECTION AND TEST PARAMETERS (OPERATIONAL, MECHANICAL, ELECTRICAL, ENVIRONMENTAL, ETC) SHALL BE DEFINED BY CSI MANUFACTURING ENGINEERING.

EACH ASSEMBLY SHALL BE IDENTIFIED WITH THE CSI PART NUMBER AND REVISION FOR THE ASSEMBLY, AND A UNIQUE SERIAL NUMBER IN HUMAN-READABLE FORMAT. SERIAL NUMBERS SHALL NOT BE DUPLICATED. THE FORMAT FOR THE SERIAL NUMBER SHALL CONTAIN AT LEAST 2 ALPHABETICAL PREFIX CHARACTERS THAT ARE RELEVANT TO THE VENDOR TO DISTINGUISH BETWEEN MULTIPLE VENDORS. THE ASSEMBLY PART NUMBER, REVISION AND SERIAL NUMBER SHALL ALSO BE LABELED ON THE PCB ASSEMBLY IN BARCODE FORMAT USING CODE 39 (PREFERRED) OR CODE 128.

EACH INDIVIDUAL, ASSEMBLED PCB SHALL BE PACKAGED IN CONDUCTIVE, STATIC SHIELDING BAGS OR CONTAINERS AND IDENTIFIED WITH ESD WARNING LABELS.

| REVISIONS | | | |
|-----------|---------|---------------|-----|
| REV. | DATE | DESCRIPTION | BY |
| 1 | 11/7/05 | SEE ECN #8587 | TLR |

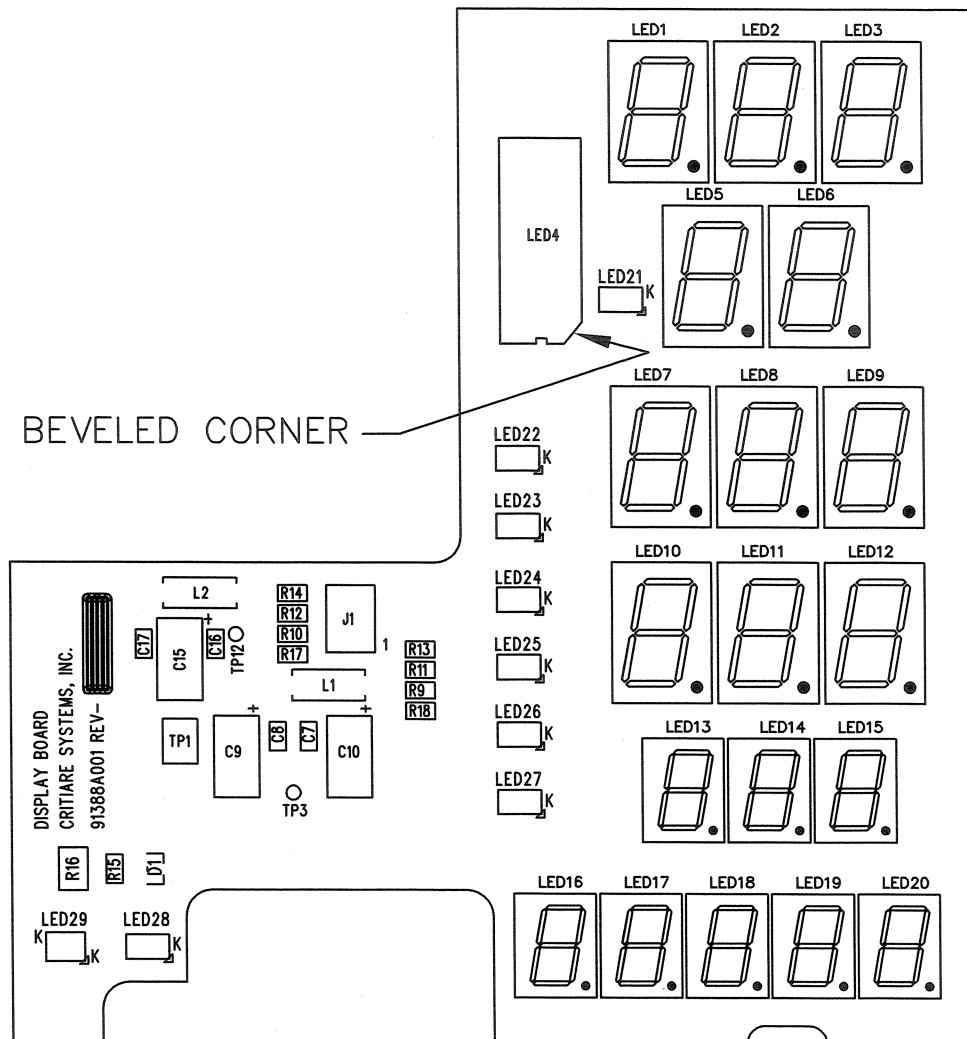

COMPONENT SIDE

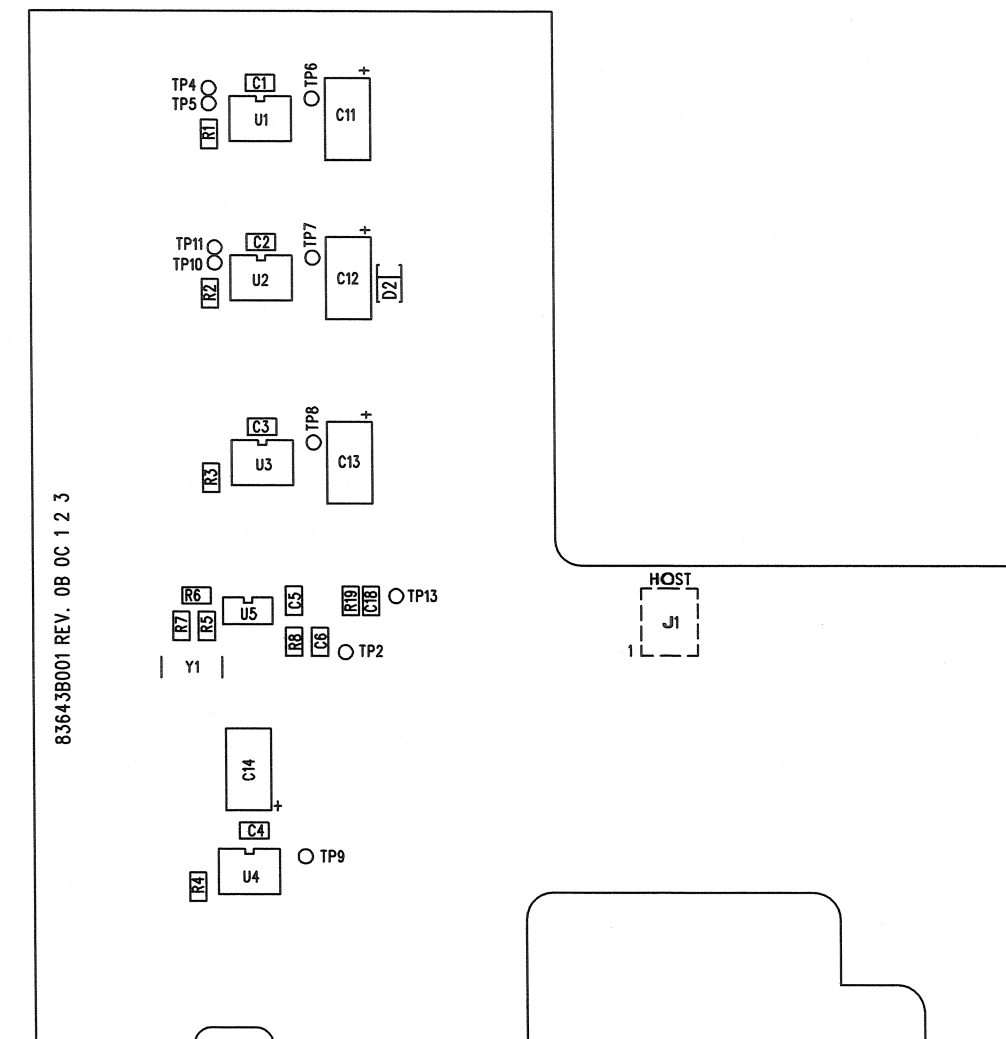

SOLDER SIDE

CRITICARE SYSTEMS, INC.

| | | |
|---------------|-------------------------------|---------------------------------|
| DRAWN BY: DBL | CHECK BY: <i>SCA 11/10/05</i> | ENG. APPR.: Roy Henning 5/29/05 |
| DATE: 8/5/04 | RELEASE DATE: | Q.A. APPR.: Mike Larsen 5/5/05 |
| SCALE: FULL | DO NOT SCALE PRINT | MFG. APPR.: Keith Hawver 5/5/05 |

| | |
|--|--|
| TOLERANCE UNLESS OTHERWISE SPECIFIED: XX: +/- .020 XXX: +/- .005 ANGLES: +/- 1 DEGREE | CONFIDENTIAL: THIS DOCUMENT CONTAINS CONFIDENTIAL INFORMATION AND MAY NOT BE COPIED OR DIVULGED WITHOUT WRITTEN CONSENT OF CRITICARE SYSTEMS, INC. |
|--|--|

| | | |
|-------------------------------------|------------------------|------------|
| TITLE: 506 N3 SERIES DISPLAY BRD | PART NO.: 91388A001 | REV.: 1 |
| DIST: — | SHEET 1 | OF 1 |

| REV | DATE | ECN # |
|-----|------|-------|
| | | |
| | | |
| | | |
| | | |
| | | |
| | | |
| | | |

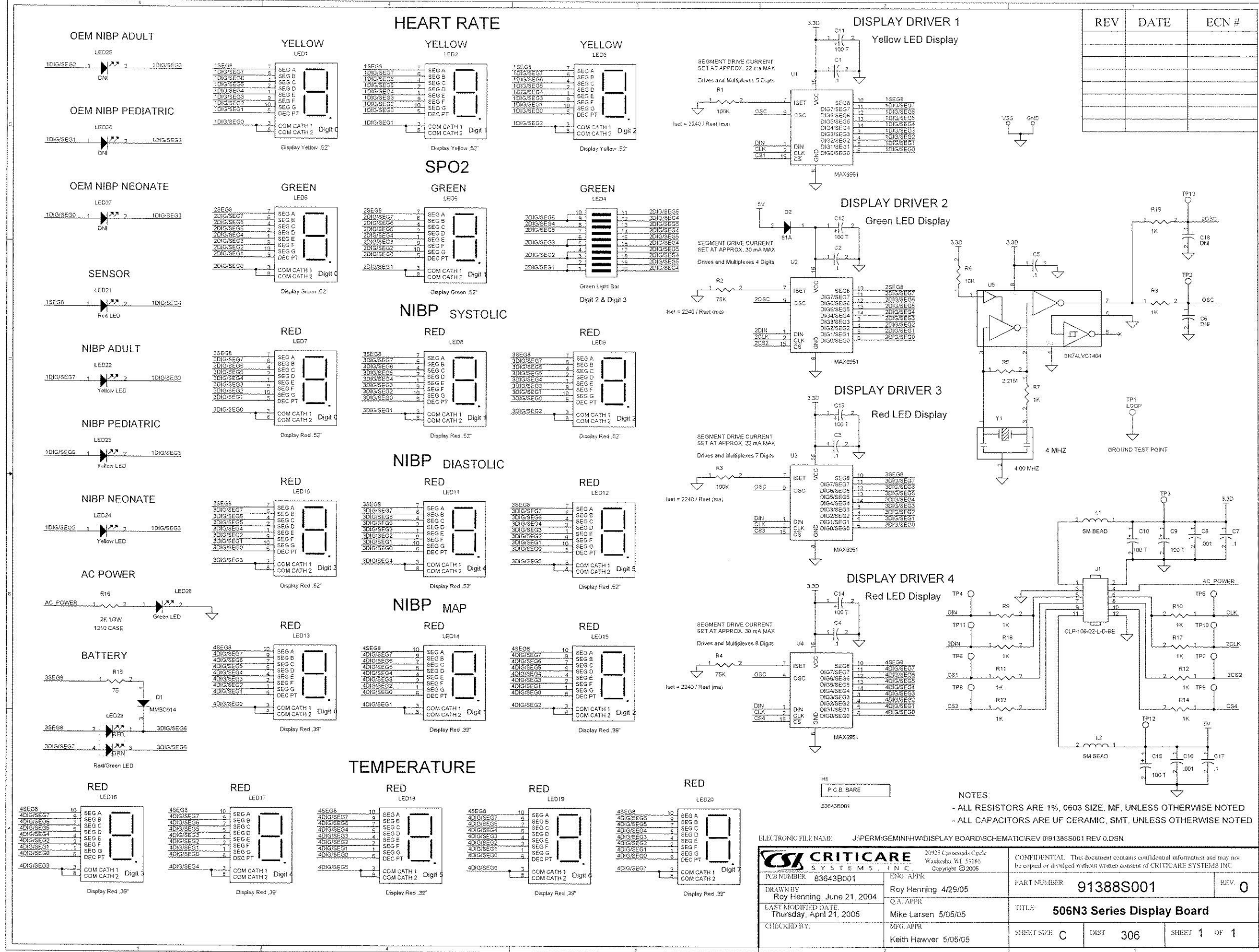

NOTES:
 - ALL RESISTORS ARE 1%, 0603 SIZE, MF, UNLESS OTHERWISE NOTED
 - ALL CAPACITORS ARE UF CERAMIC, SMT, UNLESS OTHERWISE NOTED

ELECTRONIC FILE NAME: J:\PERM\GEMINI\HW\DISPLAY BOARD\SCHEMATIC\REV 0\91388S001 REV 0.DSN

| | | | |
|--------------------|----------------------------|--|---------|
| | | 39925 Crossroads Circle Watkesha, WI 53186 Copyright ©2005 | |
| PCB NUMBER | 83643B001 | ENG APPR | |
| DRAWN BY | Roy Henning, June 21, 2004 | ROY HENNING | 4/29/05 |
| LAST MODIFIED DATE | Thursday, April 21, 2005 | MIKE LARSEN | 5/05/05 |
| CHECKED BY: | | KEITH HAWWER | 5/05/05 |
| PART NUMBER | | 91388S001 | |
| TITLE | | 506N3 Series Display Board | |
| SHEET SIZE | C | DIST | 306 |
| SHEET 1 OF 1 | | | |

| REVISIONS | | | |
|-----------|----------|---------------|-----|
| REV. | DATE | DESCRIPTION | BY |
| 1 | 10/03/05 | SEE ECN #8515 | RWK |

NOTES:

- 1.) FINISHED BOARD SHALL MEET CURRENT IPC-A-610 SPECIFICATION, CLASS 2.
- 2.) 83644B002 IS USED ON ASSEMBLY 91389A002
- 3.) BOARD TO BE FABRICATED WITH RAILS OR IN MULTIPLE UP PANELS TO AID AND OPTIMIZE COMPONENT ASSEMBLY. CONTACT CSI'S CONTRACT MANUFACTURER FOR THE PREFERRED LAYOUT. CSI TO APPROVE LAYOUT BEFORE FABRICATION.
- 4.) EACH ASSEMBLY SHALL BE IDENTIFIED WITH THE CSI PART NUMBER AND REVISION FOR THE ASSEMBLY, AND A UNIQUE SERIAL NUMBER IN HUMAN-READABLE FORMAT. SERIAL NUMBERS SHALL NOT BE DUPLICATED. THE FORMAT FOR THE SERIAL NUMBER SHALL CONTAIN AT LEAST 2 ALPHABETICAL PREFIX CHARACTERS THAT ARE RELEVANT TO THE VENDOR TO DISTINGUISH BETWEEN MULTIPLE VENDORS. THE ASSEMBLY PART NUMBER, REVISION AND SERIAL NUMBER SHALL ALSO BE LABELED ON THE PCB ASSEMBLY IN BARCODE FORMAT USING CODE 39 (PREFERRED) OR CODE 128.
- 5.) CSI RESERVES THE RIGHT TO INSPECT THIS ITEM AT THE VENDORS FACILITY. VENDORS INSPECTION SYSTEM AND MANUFACTURING PROCESS ARE SUBJECT TO REVIEW/APPROVAL, VERIFICATION AND ANALYSIS BY AUTHORIZED CSI REPRESENTATIVES. ALL CHANGES IN DESIGN, COMPONENTS, PROCESSES OR FABRICATION MUST BE AUTHORIZED IN WRITING BY CSI PRIOR TO IMPLEMENTATION. ALL DEVIATIONS FROM DRAWINGS, SPECIFICATIONS, OR OTHER REQUIREMENTS MUST BE REPORTED TO CSI FOR APPROVAL PRIOR TO SHIPMENT. ALL RAW MATERIALS USED TO PRODUCE THIS PART SHALL BE TRACEABLE TO AT LEAST A LOT LEVEL. ALL TRACEABILITY AND INSPECTION RECORDS MUST BE IDENTIFIABLE TO THE RAW MATERIALS, PARTS, ASSEMBLIES, OR DEVICES TO WHICH THEY APPLY AND SHALL BE AVAILABLE UPON REQUEST OR AUDIT BY CSI REPRESENTATIVE.

FIRST ARTICLES MUST BE INSPECTED AND ACCEPTED BY A CSI QUALITY REPRESENTATIVE PRIOR TO A PRODUCTION SHIPMENT, UNLESS OTHERWISE AUTHORIZED BY CSI. THE FIRST ARTICLES MUST BE INSPECTED AND OR TESTED FOR COMPLIANCE TO THE REQUIREMENT OF APPLICABLE ENGINEERING DRAWINGS AND SPECIFICATIONS. FIRST ARTICLES MUST BE SO MARKED AND IDENTIFIED WITH A PART NUMBER. ANY MAJOR TOOLING, PROCESS, OR COMPONENT CHANGE WILL REQUIRE A NEW FIRST ARTICLE EVALUATION.

EACH LOT OF PARTS SHALL BE ACCOMPANIED BY A LEGIBLE COPY OF A CERTIFICATE OF COMPLIANCE LISTING THE DRAWING, SPECIFICATION, PROCESS AND APPLICABLE REVISION TO WHICH THE PARTS COMPLY AND BE SIGNED OFF BY THE VENDORS QA REPRESENTATIVE.

VENDOR SHALL FURNISH A COPY OF ACTUAL INSPECTION/TEST RESULTS ASSOCIATED WITH EACH SERIALIZED ITEM. INSPECTION AND TEST PARAMETERS (OPERATIONAL, MECHANICAL, ELECTRICAL, ENVIRONMENTAL, ETC) SHALL BE DEFINED BY CSI MANUFACTURING ENGINEERING.

- 6.) EACH INDIVIDUAL, ASSEMBLED PCB SHALL BE PACKAGED IN CONDUCTIVE, STATIC SHIELDING BAGS OR CONTAINERS AND IDENTIFIED WITH ESD WARNING LABELS.

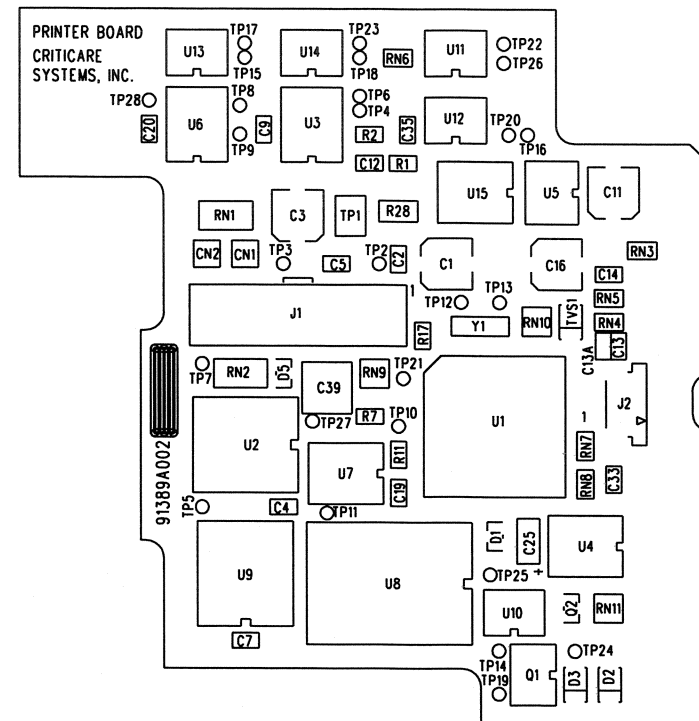

COMPONENT SIDE

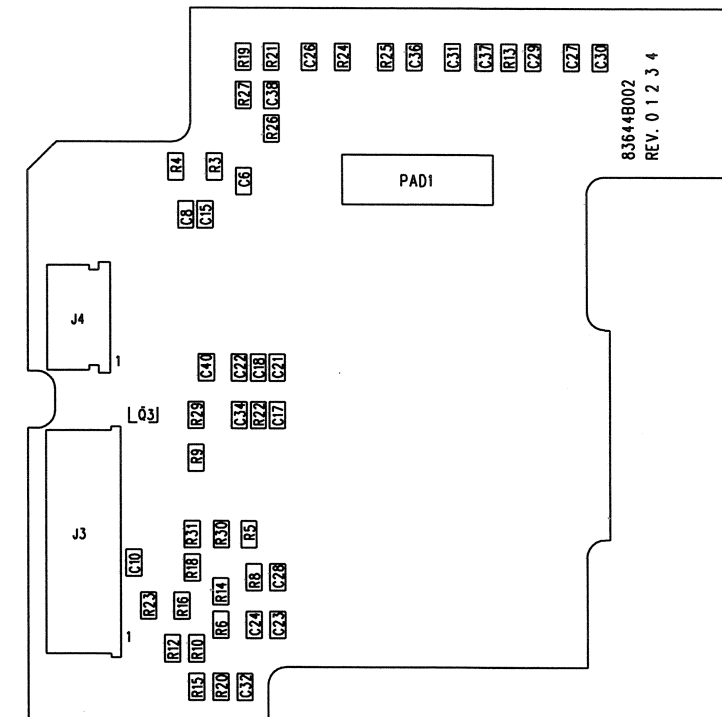

SOLDER SIDE

CRITICARE SYSTEMS, INC.

| | | |
|--|------------------------------|--|
| DRAWN BY: RWK | CHECK BY: <i>ECZ 10/7/05</i> | ENG. APPR.: R.HENNING 08/23/05 |
| DATE: 8/23/05 | RELEASE DATE: | Q.A. APPR.: A.KAPLAN 08/23/05 |
| SCALE: 1:1 | DO NOT SCALE PRINT | MFG. APPR.: LEWANDOWSKI 08/23/05 |
| TOLERANCE UNLESS OTHERWISE SPECIFIED: XX: +/- .020 XXX: +/- .005 ANGLES: +/- 1 DEGREE | | CONFIDENTIAL: THIS DOCUMENT CONTAINS CONFIDENTIAL INFORMATION AND MAY NOT BE COPIED OR DIVULGED WITHOUT WRITTEN CONSENT OF CRITICARE SYSTEMS, INC. |

| | | |
|--------------------------------------|-------------------------------|-------------------|
| TITLE: PRINTER BOARD 506N3 | PART NO.: 91389A002 | REV.: 1 |
| DIST: - | SHEET 1 | OF 1 |

| REV | DATE | ECN # |
|-----|-----------|-------|
| 1 | 9/15/2005 | 8515 |
| | | |
| | | |
| | | |
| | | |
| | | |

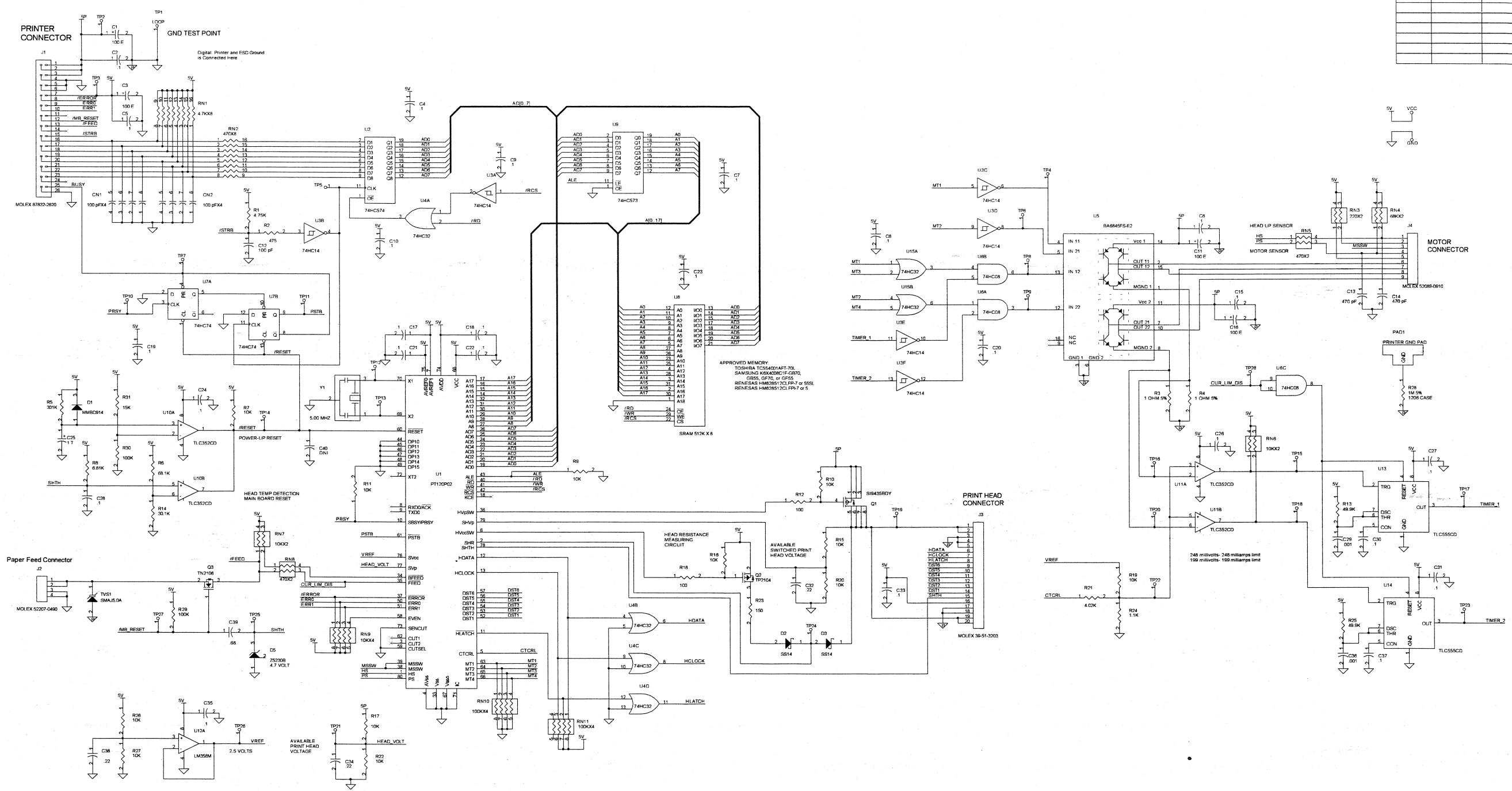

NOTES:
 - ALL DISCRETE RESISTORS ARE 1%, 0603 SIZE, MF, UNLESS OTHERWISE NOTED
 - ALL CAPACITORS ARE UF CERAMIC, SMT, UNLESS OTHERWISE NOTED

ELECTRONIC FILE NAME: J:\PERM\GEMINI\HW\PRINTER BOARD\SCHEMATIC\91389S002\REV 1\91389S002 REV 1.DSN

| | | | |
|---|---|---|--------------|
| CRITICARE 39935 Crossroads Circle Waukesha, WI 53186 Copyright © 2004 | | CONFIDENTIAL: This document contains confidential information and may not be copied or divulged without written consent of CRITICARE SYSTEMS INC. | |
| PCR NUMBER: 83644B002 | ENG. APPR: Roy Henning 08/26/2005 | PART NUMBER: 91389S002 | REV. 1 |
| DR. REV. BY: Roy Henning 10/11/2004 | Q.A. APPR: Alex Kaplan 08/26/2005 | TITLE: PRINTER BOARD 506N3 | |
| LAST MODIFIED DATE: Wednesday, August 10, 2005 | MFG. APPR: Brian Lewandowski 08/26/2005 | SHEET SIZE: D | DIST: 306 |
| CHECKED BY: | | | SHEET 1 OF 1 |

H1
P.C.B. BARE
83644B002

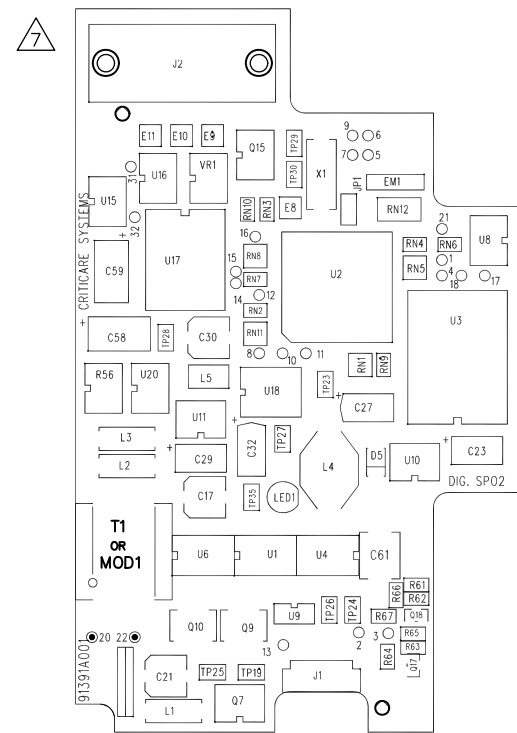

COMPONENT SIDE

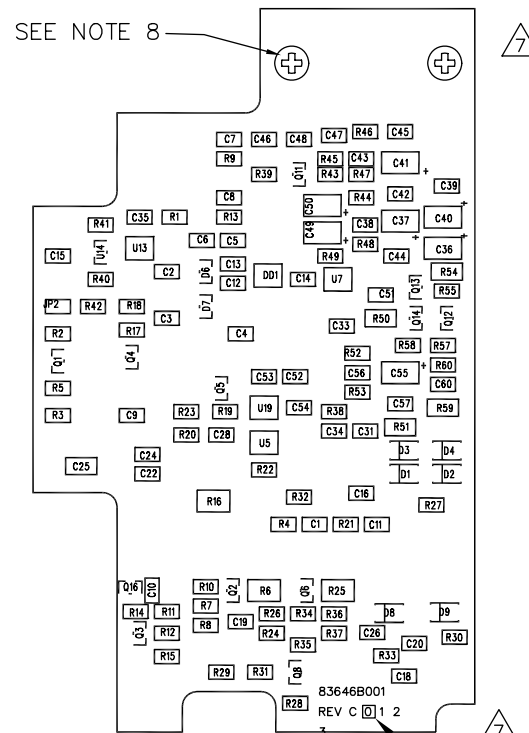

SOLDER SIDE

| REVISIONS | | | |
|-----------|----------|---------------|-----|
| REV. | DATE | DESCRIPTION | BY |
| 1 | 09/13/05 | SEE ECN #8497 | RWK |
| 2 | 02/16/06 | SEE ECN #8648 | RWK |
| 3 | 03/07/06 | SEE ECN #8723 | TLR |
| 4 | 06/27/06 | SEE ECN #8903 | JEG |
| 5 | 08/25/06 | SEE ECN #8927 | RWK |
| 6 | 11/07/06 | SEE ECN #8988 | JEG |
| 7 | 11/08/06 | SEE ECN #9009 | JEG |
| 8 | 04/23/07 | SEE ECN #9081 | RWK |

NOTES:

- 1.) FINISHED BOARD SHALL MEET CURRENT IPC-A-600/6012 STANDARDS.
- 2.) FINISHED BOARD THICKNESS SHALL BE .062+/- .010.
- 3.) 83646B001 IS USED ON ASSEMBLY 91391A001.
- 4.) BOARD TO BE FABRICATED WITH RAILS OR IN MULTIPLE UP PANELS TO AID AND OPTIMIZE COMPONENT ASSEMBLY. CONTACT CSI'S CONTRACT MANUFACTURER FOR THE PREFERRED LAYOUT. CSI TO APPROVE LAYOUT BEFORE FABRICATION.
- 6.) BOARD ASSEMBLY HOUSE IS TO PROVIDE SERIALIZATION OF EVERY BOARD.
- 7.) CSI RESERVES THE RIGHT TO INSPECT THIS ITEM AT THE VENDORS FACILITY. VENDORS INSPECTION SYSTEM AND MANUFACTURING PROCESS ARE SUBJECT TO REVIEW/APPROVAL, VERIFICATION AND ANALYSIS BY AUTHORIZED CSI REPRESENTATIVES. ALL CHANGES IN DESIGN, COMPONENTS, PROCESSES OR FABRICATION MUST BE AUTHORIZED IN WRITING BY CSI PRIOR TO IMPLEMENTATION. ALL DEVIATIONS FROM DRAWINGS, SPECIFICATIONS, OR OTHER REQUIREMENTS MUST BE REPORTED TO CSI FOR APPROVAL PRIOR TO SHIPMENT. ALL RAW MATERIALS USED TO PRODUCE THIS PART SHALL BE TRACEABLE TO AT LEAST A LOT LEVEL. ALL TRACEABILITY AND INSPECTION RECORDS MUST BE IDENTIFIABLE TO THE RAW MATERIALS, PARTS, ASSEMBLIES, OR DEVICES TO WHICH THEY APPLY AND SHALL BE AVAILABLE UPON REQUEST OR AUDIT BY CSI REPRESENTATIVE.

FIRST ARTICLES MUST BE INSPECTED AND ACCEPTED BY A CSI QUALITY REPRESENTATIVE PRIOR TO A PRODUCTION SHIPMENT, UNLESS OTHERWISE AUTHORIZED BY CSI. THE FIRST ARTICLES MUST BE INSPECTED AND OR TESTED FOR COMPLIANCE TO THE REQUIREMENT OF APPLICABLE ENGINEERING DRAWINGS AND SPECIFICATIONS. FIRST ARTICLES MUST BE SO MARKED AND IDENTIFIED WITH A PART NUMBER. ANY MAJOR TOOLING, PROCESS, OR COMPONENT CHANGE WILL REQUIRE A NEW FIRST ARTICLE EVALUATION.

EACH LOT OF PARTS SHALL BE ACCOMPANIED BY A LEGIBLE COPY OF A CERTIFICATE OF COMPLIANCE LISTING THE DRAWING, SPECIFICATION, PROCESS AND APPLICABLE REVISION TO WHICH THE PARTS COMPLY AND BE SIGNED OFF BY THE VENDORS QA REPRESENTATIVE.

VENDOR SHALL FURNISH A COPY OF ACTUAL INSPECTION/TEST RESULTS ASSOCIATED WITH EACH SERIALIZED ITEM. INSPECTION AND TEST PARAMETERS (OPERATIONAL, MECHANICAL, ELECTRICAL, ENVIRONMENTAL, ETC) SHALL BE DEFINED BY CSI MANUFACTURING ENGINEERING.

EACH ASSEMBLY SHALL BE IDENTIFIED WITH THE CSI PART NUMBER AND REVISION FOR THE ASSEMBLY, AND A UNIQUE SERIAL NUMBER IN HUMAN-READABLE FORMAT. SERIAL NUMBERS SHALL NOT BE DUPLICATED. THE FORMAT FOR THE SERIAL NUMBER SHALL CONTAIN AT LEAST 2 ALPHABETICAL PREFIX CHARACTERS THAT ARE RELEVANT TO THE VENDOR TO DISTINGUISH BETWEEN MULTIPLE VENDORS. THE ASSEMBLY PART NUMBER, REVISION AND SERIAL NUMBER SHALL ALSO BE LABELED ON THE PCB ASSEMBLY IN BARCODE FORMAT USING CODE 39 (PREFERRED) OR CODE 128.

EACH INDIVIDUAL, ASSEMBLED PCB SHALL BE PACKAGED IN CONDUCTIVE, STATIC SHIELDING BAGS OR CONTAINERS AND IDENTIFIED WITH ESD WARNING LABELS.

- 8.) ADD PN: 40995B001, ITEM 2, QTY 2 INTO DB-9 CONNECTOR HOLES. TORQUE TO 5 IN LBS. INSTALL PRIOR TO WAVE SOLDER.

VENDOR SHOULD COMPLY WITH THE FOLLOWING CSI QUALITY REQUIREMENTS: Q1, Q2, Q4, Q5, Q6, Q7, Q10, Q11 AND Q16. IN ADDITION THE QUALITY REQUIREMENTS Q9, Q13 AND Q17 APPLY. SEE CSI WEB SITE (www.csiusa.com/pdf/QA_Requirements.pdf) FOR THE DEFINITION OF THE QUALITY REQUIREMENTS

| | | |
|--|--------------------|--|
| CSI CRITICARE SYSTEMS, INC. | | |
| DRAWN BY: DBL | CHECK BY: | ENG. APPR.: D. RIECK 05/05/05 |
| DATE: 1/6/05 | RELEASE DATE: | Q.A. APPR.: M. LARSEN 05/05/05 |
| SCALE: 1.25:1 | DO NOT SCALE PRINT | MFG. APPR.: D. CARLSON 05/05/05 |
| TOLERANCE UNLESS OTHERWISE SPECIFIED: XX: +/- .020 XXX: +/- .005 ANGLES: +/- 1 DEGREE | | CONFIDENTIAL: THIS DOCUMENT CONTAINS CONFIDENTIAL INFORMATION AND MAY NOT BE COPIED OR DIVULGED WITHOUT WRITTEN CONSENT OF CRITICARE SYSTEMS, INC. |
| TITLE: ASSY, DIGITAL SPO2 (DOX) MODULE | | PART NO.: 91391A001 |
| | | REV.: 8 |
| DIST: -- | | SHEET 1 OF 1 |

| REV | DATE | ECN # |
|-----|---------|---------------|
| 1 | 6/27/06 | SEE ECN #8903 |
| 2 | 11/2/06 | SEE ECN #9009 |
| 3 | 1/22/07 | SEE ECN #9081 |

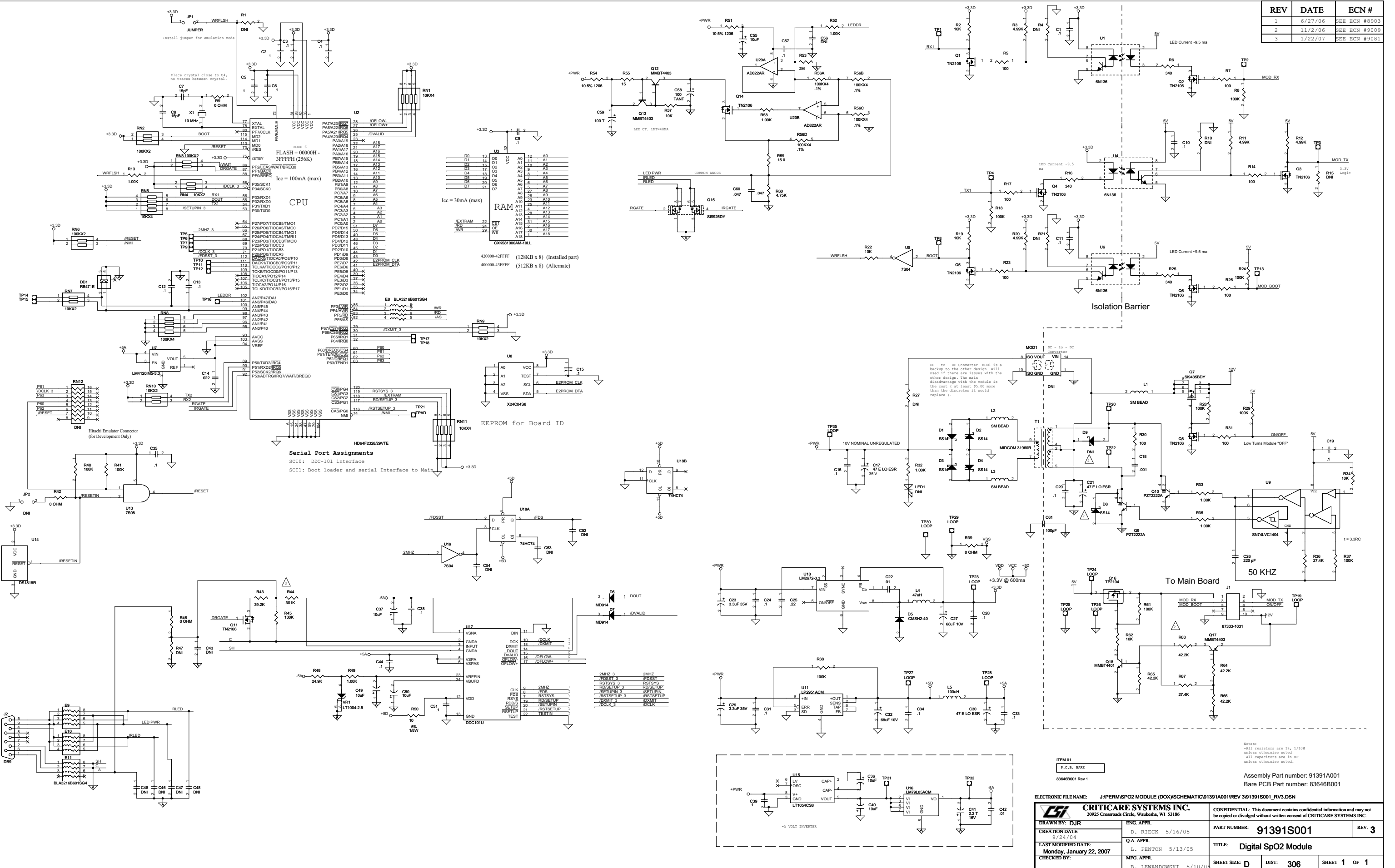

Notes:
 -All resistors are 1%/10W unless otherwise noted
 -All capacitors are in uF unless otherwise noted.

Assembly Part number: 91391A001
 Bare PCB Part number: 83646B001

| | | | |
|--|-----------------------------------|---|-----------|
| ELECTRONIC FILE NAME: J:\PERM\SPO2 MODULE (DOX)\SCHEMATIC\91391A001\REV 3\91391S001_REV3.DSN | | CONFIDENTIAL: This document contains confidential information and may not be copied or divulged without written consent of CRITICARE SYSTEMS INC. | |
| CS CRITICARE SYSTEMS INC. 20925 Crossroads Circle, Waukesha, WI 53186 | | PART NUMBER: 91391S001 | |
| DRAWN BY: DJR | ENG. APPR: D. RIECK 5/16/05 | REV. 3 | |
| CREATION DATE: 9/24/04 | Q.A. APPR: L. PENTON 5/13/05 | TITLE: Digital SpO2 Module | |
| LAST MODIFIED DATE: Monday, January 22, 2007 | MFG. APPR: B. LEWANDOWSKI 5/10/05 | SHEET SIZE: D | DIST: 306 |
| CHECKED BY: | | SHEET 1 OF 1 | |

ITEM 01
 P.C.B. BASE
 83646B001 Rev 1

| REVISIONS | | | |
|-----------|----------|---------------|-----|
| REV. | DATE | DESCRIPTION | BY |
| 1 | 07/26/06 | SEE ECN #8903 | RWK |
| 2 | 10/25/06 | SEE ECN #8998 | JEG |
| 3 | 4/17/07 | SEE ECN #9144 | DBL |

SEE NOTE 5

S1 MUST BE FULLY INSERTED AND SQUARELY SEATED ONTO PCB

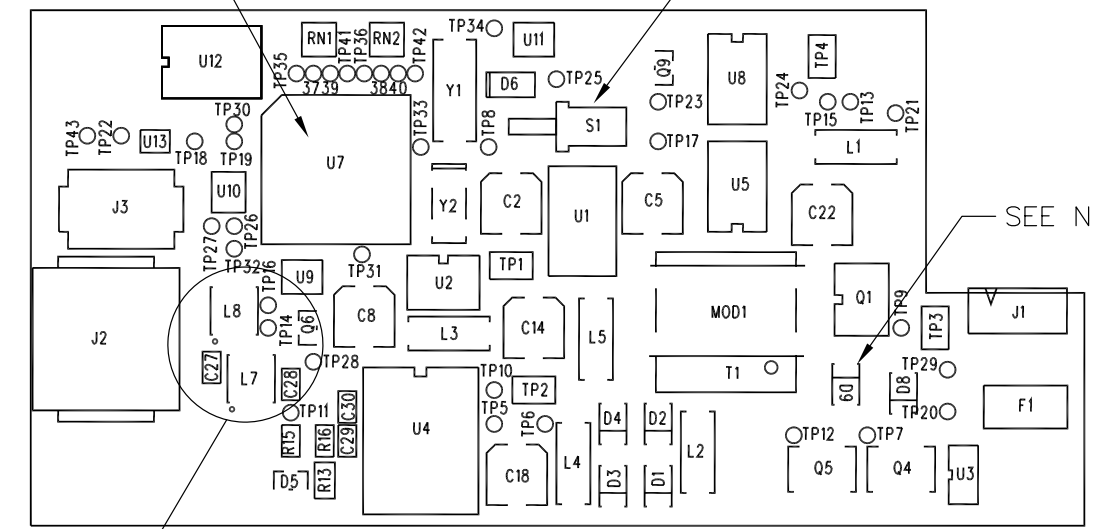

COMPONENT/TOP SIDE

SEE NOTE 4

FAB REVISION

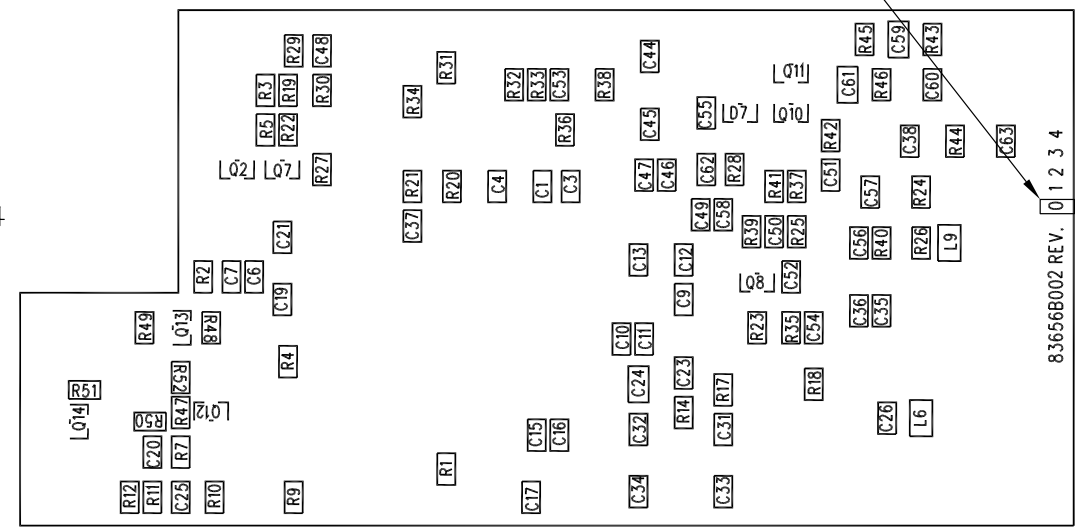

SOLDER/BOTTOM SIDE

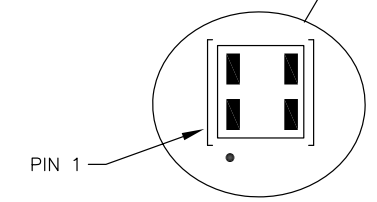

L7 and L8 MOUNTING ORIENTATION

NOTES:

- 1.) THIS PCB ASSEMBLY SHALL MEET CURRENT IPC-A-610 SPECIFICATION, CLASS 2.
 - 2.) APPLIED LABELS MUST BE NON-CONDUCTIVE.
 - 3.) PLACE REVISION AND SERIAL NUMBER LABELS ON SOLDER SIDE, NOT COVERING ANY MOUNTING HOLES, VIAS, OR SOLDER JOINTS.
 - 4.) REFER TO BILL OF MATERIAL FOR COMPLETE LISTING OF COMPONENTS NOT INSTALLED (DNI).
 - 5.) MICROPROCESSOR MUST BE PROGRAMMED WITH SOFTWARE PRIOR TO FUNCTIONAL TESTING OF PCB ASSEMBLY.
 - 6.) EACH ASSEMBLY SHALL BE IDENTIFIED WITH THE CSI PART NUMBER AND REVISION FOR THE ASSEMBLY, AND A UNIQUE SERIAL NUMBER IN HUMAN-READABLE FORMAT. SERIAL NUMBERS SHALL NOT BE DUPLICATED. THE FORMAT FOR THE SERIAL NUMBER SHALL CONTAIN AT LEAST 2 ALPHABETICAL PREFIX CHARACTERS THAT ARE RELEVANT TO THE VENDOR TO DISTINGUISH BETWEEN MULTIPLE VENDORS. THE ASSEMBLY PART NUMBER, REVISION AND SERIAL NUMBER SHALL ALSO BE LABELED ON THE PCB ASSEMBLY IN BARCODE FORMAT USING CODE 39 (PREFERRED) OR CODE 128.
 - 7.) CSI RESERVES THE RIGHT TO INSPECT THIS ITEM AT THE VENDORS FACILITY. VENDORS INSPECTION SYSTEM AND MANUFACTURING PROCESS ARE SUBJECT TO REVIEW/APPROVAL, VERIFICATION AND ANALYSIS BY AUTHORIZED CSI REPRESENTATIVES. ALL CHANGES IN DESIGN, COMPONENTS, PROCESSES OR FABRICATION MUST BE AUTHORIZED IN WRITING BY CSI PRIOR TO IMPLEMENTATION. ALL DEVIATIONS FROM DRAWINGS, SPECIFICATIONS, OR OTHER REQUIREMENTS MUST BE REPORTED TO CSI FOR APPROVAL PRIOR TO SHIPMENT. ALL RAW MATERIALS USED TO PRODUCE THIS PART SHALL BE TRACEABLE TO AT LEAST A LOT LEVEL. ALL TRACEABILITY AND INSPECTION RECORDS MUST BE IDENTIFIABLE TO THE RAW MATERIALS, PARTS, ASSEMBLIES, OR DEVICES TO WHICH THEY APPLY AND SHALL BE AVAILABLE UPON REQUEST OR AUDIT BY CSI REPRESENTATIVE.
- FIRST ARTICLES MUST BE INSPECTED AND ACCEPTED BY A CSI QUALITY REPRESENTATIVE PRIOR TO A PRODUCTION SHIPMENT, UNLESS OTHERWISE AUTHORIZED BY CSI. THE FIRST ARTICLES MUST BE INSPECTED AND OR TESTED FOR COMPLIANCE TO THE REQUIREMENT OF APPLICABLE ENGINEERING DRAWINGS AND SPECIFICATIONS. FIRST ARTICLES MUST BE SO MARKED AND IDENTIFIED WITH A PART NUMBER. ANY MAJOR TOOLING, PROCESS, OR COMPONENT CHANGE WILL REQUIRE A NEW FIRST ARTICLE EVALUATION.
- EACH LOT OF PARTS SHALL BE ACCOMPANIED BY A LEGIBLE COPY OF A CERTIFICATE OF COMPLIANCE LISTING THE DRAWING, SPECIFICATION, PROCESS AND APPLICABLE REVISION TO WHICH THE PARTS COMPLY AND BE SIGNED OFF BY THE VENDORS QA REPRESENTATIVE.
- VENDOR SHALL FURNISH A COPY OF ACTUAL INSPECTION/TEST RESULTS ASSOCIATED WITH EACH SERIALIZED ITEM. INSPECTION AND TEST PARAMETERS (OPERATIONAL, MECHANICAL, ELECTRICAL, ENVIRONMENTAL, ETC) SHALL BE DEFINED BY BY CSI MANUFACTURING ENGINEERING.
- 8.) EACH INDIVIDUAL, ASSEMBLED PCB SHALL BE PACKAGED IN CONDUCTIVE, STATIC SHIELDING BAGS OR CONTAINERS AND IDENTIFIED WITH ESD WARNING LABELS.

VENDOR SHOULD COMPLY WITH THE FOLLOWING CSI QUALITY REQUIREMENTS: Q1, Q2, Q4, Q5, Q6, Q7, Q10, Q11 AND Q16. IN ADDITION THE QUALITY REQUIREMENTS Q9, Q13 AND Q17 APPLY. SEE CSI WEB SITE (www.csiusa.com/pdf/QA_Requirements.pdf) FOR THE DEFINITION OF THE QUALITY REQUIREMENTS

| | | |
|--|--------------------|--|
| CSI CRITICARE SYSTEMS, INC. | | |
| DRAWN BY: JEG | CHECK BY: | ENG. APPR.: R. HENNING 06/01/2006 |
| DATE: 03-20-2006 | RELEASE DATE: | Q.A. APPR.: A. KAPLAN 06/01/2006 |
| SCALE: NONE | DO NOT SCALE PRINT | MFG. APPR.: B. LEWANDOWSKI 06/01/2006 |
| TOLERANCE UNLESS OTHERWISE SPECIFIED: XX: +/- .020 XXX: +/- .005 ANGLES: +/- 1 DEGREE | | CONFIDENTIAL: THIS DOCUMENT CONTAINS CONFIDENTIAL INFORMATION AND MAY NOT BE COPIED OR DIVULGED WITHOUT WRITTEN CONSENT OF CRITICARE SYSTEMS, INC. |
| TITLE: ALARIS TURBO TEMP PCB ASSY | | PART NO.: 91403A001 |
| DIST: -- | | REV.: 3 |
| SHEET 1 OF 1 | | |

| REV | DATE | ECN # |
|-----|----------|-------|
| 1 | 6/22/06 | 8903 |
| 2 | 10/18/06 | 8998 |
| | | |
| | | |
| | | |
| | | |
| | | |
| | | |
| | | |

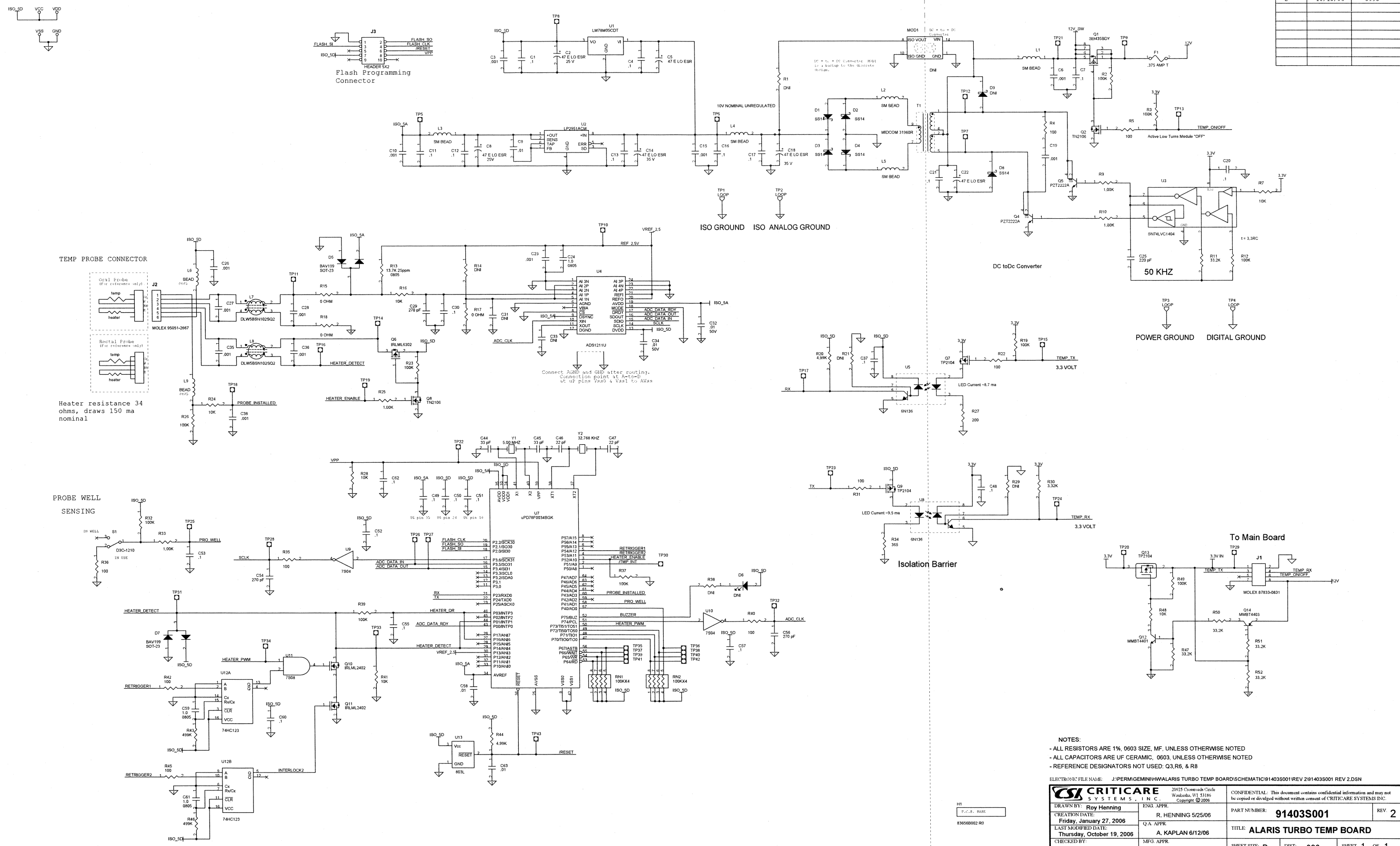

TEMP PROBE CONNECTOR

Heater resistance 34 ohms, draws 150 ma nominal

PROBE WELL SENSING

- NOTES:
- ALL RESISTORS ARE 1%, 0603 SIZE, MF, UNLESS OTHERWISE NOTED
 - ALL CAPACITORS ARE UF CERAMIC, 0603, UNLESS OTHERWISE NOTED
 - REFERENCE DESIGNATORS NOT USED: Q3, R6, & R8

ELECTRONIC FILE NAME: J:\PERM\GEMINI\HW\ALARIS TURBO TEMP BOARD\SCHEMATIC\914035001\REV 2\914035001 REV 2.DSN

| | | | | | |
|--|-------------------------------|---|-----------|--|--|
| | | <small>3925 Crossroads Circle Waukesha, WI 53186 Copyright © 2006</small> | | <small>CONFIDENTIAL: This document contains confidential information and may not be copied or divulged without written consent of CRITICARE SYSTEMS INC.</small> | |
| DRAWN BY: Roy Henning | ENG. APPR. R. HENNING 5/25/06 | PART NUMBER: 914035001 | REV 2 | | |
| CREATION DATE: Friday, January 27, 2006 | Q.A. APPR. A. KAPLAN 6/12/06 | TITLE: ALARIS TURBO TEMP BOARD | | | |
| LAST MODIFIED DATE: Thursday, October 19, 2006 | MFG. APPR. K. HAWVER 6/28/06 | SHEET SIZE: D | DIST: 306 | SHEET 1 OF 1 | |