



Intelligent Control Panel
SLC
Wiring Manual



Fire Alarm & Emergency Communication System Limitations

While a life safety system may lower insurance rates, it is not a substitute for life and property insurance!

An automatic fire alarm system—typically made up of smoke detectors, heat detectors, manual pull stations, audible warning devices, and a fire alarm control panel (FACP) with remote notification capability—can provide early warning of a developing fire. Such a system, however, does not assure protection against property damage or loss of life resulting from a fire.

An emergency communication system—typically made up of an automatic fire alarm system (as described above) and a life safety communication system that may include an autonomous control unit (ACU), local operating console (LOC), voice communication, and other various interoperable communication methods—can broadcast a mass notification message. Such a system, however, does not assure protection against property damage or loss of life resulting from a fire or life safety event.

The Manufacturer recommends that smoke and/or heat detectors be located throughout a protected premises following the recommendations of the current edition of the National Fire Protection Association Standard 72 (NFPA 72), manufacturer's recommendations, State and local codes, and the recommendations contained in the Guide for Proper Use of System Smoke Detectors, which is made available at no charge to all installing dealers. This document can be found at <http://www.systemsensor.com/appguides/>. A study by the Federal Emergency Management Agency (an agency of the United States government) indicated that smoke detectors may not go off in as many as 35% of all fires. While fire alarm systems are designed to provide early warning against fire, they do not guarantee warning or protection against fire. A fire alarm system may not provide timely or adequate warning, or simply may not function, for a variety of reasons:

Smoke detectors may not sense fire where smoke cannot reach the detectors such as in chimneys, in or behind walls, on roofs, or on the other side of closed doors. Smoke detectors also may not sense a fire on another level or floor of a building. A second-floor detector, for example, may not sense a first-floor or basement fire.

Particles of combustion or "smoke" from a developing fire may not reach the sensing chambers of smoke detectors because:

- Barriers such as closed or partially closed doors, walls, chimneys, even wet or humid areas may inhibit particle or smoke flow.
- Smoke particles may become "cold," stratify, and not reach the ceiling or upper walls where detectors are located.
- Smoke particles may be blown away from detectors by air outlets, such as air conditioning vents.
- Smoke particles may be drawn into air returns before reaching the detector.

The amount of "smoke" present may be insufficient to alarm smoke detectors. Smoke detectors are designed to alarm at various levels of smoke density. If such density levels are not created by a developing fire at the location of detectors, the detectors will not go into alarm.

Smoke detectors, even when working properly, have sensing limitations. Detectors that have photoelectronic sensing chambers tend to detect smoldering fires better than flaming fires, which have little visible smoke. Detectors that have ionizing-type sensing chambers tend to detect fast-flaming fires better than smoldering fires. Because fires develop in different ways and are often unpredictable in their growth, neither type of detector is necessarily best and a given type of detector may not provide adequate warning of a fire.

Smoke detectors cannot be expected to provide adequate warning of fires caused by arson, children playing with matches (especially in bedrooms), smoking in bed, and violent explosions

(caused by escaping gas, improper storage of flammable materials, etc.).

Heat detectors do not sense particles of combustion and alarm only when heat on their sensors increases at a predetermined rate or reaches a predetermined level. Rate-of-rise heat detectors may be subject to reduced sensitivity over time. For this reason, the rate-of-rise feature of each detector should be tested at least once per year by a qualified fire protection specialist. Heat detectors are designed to protect property, not life.

IMPORTANT! Smoke detectors must be installed in the same room as the control panel and in rooms used by the system for the connection of alarm transmission wiring, communications, signaling, and/or power. If detectors are not so located, a developing fire may damage the alarm system, compromising its ability to report a fire.

Audible warning devices such as bells, horns, strobes, speakers and displays may not alert people if these devices are located on the other side of closed or partly open doors or are located on another floor of a building. Any warning device may fail to alert people with a disability or those who have recently consumed drugs, alcohol, or medication. Please note that:

- An emergency communication system may take priority over a fire alarm system in the event of a life safety emergency.
- Voice messaging systems must be designed to meet intelligibility requirements as defined by NFPA, local codes, and Authorities Having Jurisdiction (AHJ).
- Language and instructional requirements must be clearly disseminated on any local displays.
- Strobes can, under certain circumstances, cause seizures in people with conditions such as epilepsy.
- Studies have shown that certain people, even when they hear a fire alarm signal, do not respond to or comprehend the meaning of the signal. Audible devices, such as horns and bells, can have different tonal patterns and frequencies. It is the property owner's responsibility to conduct fire drills and other training exercises to make people aware of fire alarm signals and instruct them on the proper reaction to alarm signals.
- In rare instances, the sounding of a warning device can cause temporary or permanent hearing loss.

A life safety system will not operate without any electrical power. If AC power fails, the system will operate from standby batteries only for a specified time and only if the batteries have been properly maintained and replaced regularly.

Equipment used in the system may not be technically compatible with the control panel. It is essential to use only equipment listed for service with your control panel.

Telephone lines needed to transmit alarm signals from a premises to a central monitoring station may be out of service or temporarily disabled. For added protection against telephone line failure, backup radio transmission systems are recommended.

The most common cause of life safety system malfunction is inadequate maintenance. To keep the entire life safety system in excellent working order, ongoing maintenance is required per the manufacturer's recommendations, and UL and NFPA standards. At a minimum, the requirements of NFPA 72 shall be followed. Environments with large amounts of dust, dirt, or high air velocity require more frequent maintenance. A maintenance agreement should be arranged through the local manufacturer's representative. Maintenance should be scheduled as required by National and/or local fire codes and should be performed by authorized professional life safety system installers only. Adequate written records of all inspections should be kept.

Limit-D2-2016

Installation Precautions

Adherence to the following will aid in problem-free installation with long-term reliability:

WARNING - Several different sources of power can be connected to the fire alarm control panel. Disconnect all sources of power before servicing. Control unit and associated equipment may be damaged by removing and/or inserting cards, modules, or interconnecting cables while the unit is energized. Do not attempt to install, service, or operate this unit until manuals are read and understood.

CAUTION - System Re-acceptance Test after Software Changes: To ensure proper system operation, this product must be tested in accordance with NFPA 72 after any programming operation or change in site-specific software. Re-acceptance testing is required after any change, addition or deletion of system components, or after any modification, repair or adjustment to system hardware or wiring. All components, circuits, system operations, or software functions known to be affected by a change must be 100% tested. In addition, to ensure that other operations are not inadvertently affected, at least 10% of initiating devices that are not directly affected by the change, up to a maximum of 50 devices, must also be tested and proper system operation verified.

This system meets NFPA requirements for operation at 0-49° C/32-120° F and at a relative humidity 93% ± 2% RH (non-condensing) at 32°C ± 2°C (90°F ± 3°F). However, the useful life of the system's standby batteries and the electronic components may be adversely affected by extreme temperature ranges and humidity. Therefore, it is recommended that this system and its peripherals be installed in an environment with a normal room temperature of 15-27° C/60-80° F.

Verify that wire sizes are adequate for all initiating and indicating device loops. Most devices cannot tolerate more than a 10% I.R. drop from the specified device voltage.

Like all solid state electronic devices, this system may operate erratically or can be damaged when subjected to lightning induced transients. Although no system is completely immune from lightning transients and interference, proper grounding will reduce susceptibility. Overhead or outside aerial wiring is not recommended, due to an increased susceptibility to nearby lightning strikes. Consult with the Technical Services Department if any problems are anticipated or encountered.

Disconnect AC power and batteries prior to removing or inserting circuit boards. Failure to do so can damage circuits.

Remove all electronic assemblies prior to any drilling, filing, reaming, or punching of the enclosure. When possible, make all cable entries from the sides or rear. Before making modifications, verify that they will not interfere with battery, transformer, or printed circuit board location.

Do not tighten screw terminals more than 9 in-lbs. Overtightening may damage threads, resulting in reduced terminal contact pressure and difficulty with screw terminal removal.

This system contains static-sensitive components. Always ground yourself with a proper wrist strap before handling any circuits so that static charges are removed from the body. Use static suppressive packaging to protect electronic assemblies removed from the unit.

Units with a touchscreen display should be cleaned with a dry, clean, lint free/microfiber cloth. If additional cleaning is required, apply a small amount of Isopropyl alcohol to the cloth and wipe clean. Do not use detergents, solvents, or water for cleaning. Do not spray liquid directly onto the display.

Follow the instructions in the installation, operating, and programming manuals. These instructions must be followed to avoid damage to the control panel and associated equipment. FACP operation and reliability depend upon proper installation.

Precau-D2-11-2017

FCC Warning

WARNING: This equipment generates, uses, and can radiate radio frequency energy and if not installed and used in accordance with the instruction manual may cause interference to radio communications. It has been tested and found to comply with the limits for class A computing devices pursuant to Subpart B of Part 15 of FCC Rules, which is designed to provide reasonable protection against such interference when devices are operated in a commercial environment. Operation of this equipment in a residential area is likely to cause interference, in which case the user will be required to correct the interference at his or her own expense.

Canadian Requirements

This digital apparatus does not exceed the Class A limits for radiation noise emissions from digital apparatus set out in the Radio Interference Regulations of the Canadian Department of Communications.

Le présent appareil numérique n'émet pas de bruits radioélectriques dépassant les limites applicables aux appareils numériques de la classe A prescrites dans le Règlement sur le brouillage radioélectrique édicté par le ministère des Communications du Canada.

LiteSpeed™ and Lite-Connect™ are trademarks; and Fire-Lite® Alarms, Honeywell®, and SWIFT® are registered trademarks of Honeywell International Inc. Microsoft® and Windows® are registered trademarks of the Microsoft Corporation. Chrome™ and Google™ are trademarks of Google Inc. Firefox® is a registered trademark of The Mozilla Foundation.

©2019 by Honeywell International Inc. All rights reserved. Unauthorized use of this document is strictly prohibited.

Software Downloads

In order to supply the latest features and functionality in fire alarm and life safety technology to our customers, we make frequent upgrades to the embedded software in our products. To ensure that you are installing and programming the latest features, we strongly recommend that you download the most current version of software for each product prior to commissioning any system. Contact Technical Support with any questions about software and the appropriate version for a specific application.

Documentation Feedback

Your feedback helps us keep our documentation up-to-date and accurate. If you have any comments or suggestions about our online Help or printed manuals, you can email us.

Please include the following information:

- Product name and version number (if applicable)
- Printed manual or online Help
- Topic Title (for online Help)
- Page number (for printed manual)
- Brief description of content you think should be improved or corrected
- Your suggestion for how to correct/improve documentation

Send email messages to:

FireSystems.TechPubs@honeywell.com

Please note this email address is for documentation feedback only. If you have any technical issues, please contact Technical Services.

Table of Contents

Section 1: Introduction	8
1.1: Scope.....	8
1.1.1: Reference Documentation	8
1.2: Overview.....	10
1.3: Polling Protocols.....	10
1.3.1: Available Protocols.....	10
1.3.2: Protocol Use.....	10
1.4: Devices	10
1.4.1: Isolator Modules	10
1.4.2: Monitor Modules	10
1.4.3: Control Modules	10
1.4.4: Relay Modules	11
1.4.5: Multiple Input/Output Modules	11
1.4.6: Intelligent Detectors.....	11
1.4.7: Manual Pull Station.....	12
1.4.8: Wireless Gateway	12
1.4.9: 300 Series Addressable Devices	12
1.4.10: 900 Series Addressable Devices.....	12
1.5: SLC Capacity.....	12
1.6: SLC Performance.....	12
1.7: Surge Suppression.....	13
1.8: LED Operation.....	13
Section 2: Wiring Requirements	14
2.1: Wire Sizing	14
2.1.1: CLIP (Classic Loop Interface Protocol) Mode.....	14
2.1.2: LiteSpeed Mode.....	14
2.2: Measuring Resistance & Length.....	14
2.2.1: Two-Wire SLC - Style 4 (Class B).....	14
2.2.2: Four-Wire SLC Style 6 & 7 (Class A).....	15
2.3: Shield Wire Termination.....	16
2.4: Control Panel Terminal Blocks.....	17
2.4.1: MS-9200	17
2.4.2: MS-9600, MS-9600LS, & MS-9600UDLS.....	17
2.4.3: MS-9200UDLS (Software Version 3.0).....	18
2.4.4: MS-9200UD & MS-9200UDLS (Versions 1 and 2).....	18
2.4.5: MS-9050UD	18
2.4.6: ES-50X	19
2.4.7: ES-200X	19
Section 3: SLC Circuits without Isolators	20
3.1: Overview.....	20
3.2: NFPA Style 4 SLC	20
3.3: NFPA Style 6 SLC	21
Section 4: SLC Circuits with Isolators.....	22
4.1: Fault Isolator Devices	22
4.1.1: Isolating an SLC Branch.....	22
4.1.2: Wiring an Isolator Module.....	22
4.2: NFPA Style 4 SLC Using Isolator Modules	24
4.3: NFPA Style 6 SLC Using Isolator Modules	26
4.4: NFPA Style 7 SLC Using Isolator Modules	27
Section 5: Monitor Modules.....	28
5.1: Descriptions	28
5.1.1: Addressable Monitor Modules	28
5.1.2: Zone Interface Modules	30
5.1.3: Dual Monitor Module	32
5.1.4: Mini Monitor Module	32
5.2: Installation	32
5.2.1: Setting an SLC address for a Single Point Module	33
5.2.2: Setting an SLC address for a Multi-Point Module	33
5.3: MMF-300 Wiring Diagrams.....	34

5.3.1: Wiring a NFPA Style B IDC with an MMF-300.....	34
5.3.2: Wiring a NFPA Style D IDC with an MMF-300	35
5.3.3: MMF-300 Wiring for Emergency Alarm System Applications	36
5.4: MMF-300-10 Wiring Diagrams.....	37
5.4.1: Wiring a NFPA Style B IDC with an MMF-300-10	37
5.4.2: Wiring a NFPA Style D IDC with an MMF-300-10	38
5.5: MDF-300 Wiring Diagrams.....	39
5.5.1: Wiring a NFPA Style B IDC with an MDF-300	39
5.6: MMF-302 Wiring Diagrams.....	40
5.6.1: Wiring a NFPA Style B IDC with an MMF-302.....	40
5.6.2: Wiring a NFPA Style D IDC with an MMF-302	41
5.7: MMF-302-6 Wiring Diagrams.....	42
5.7.1: Wiring a NFPA Style B IDC with an MMF-302-6	42
5.7.2: Wiring a NFPA Style D IDC with an MMF-302-6.....	43
Section 6: Control Modules	44
6.1: Description.....	44
6.2: CMF-300 Installation.....	44
6.2.1: Setting an SLC address for a CMF-300 Module	44
6.2.2: Wiring a Notification Appliance Circuit (NAC) with a CMF-300.....	44
6.3: Wiring a CMF-300 Module	44
6.3.1: Wiring a Style Y NAC (Two-Wire) with Addressable Control Modules	44
6.3.2: Wiring a Style Z NAC (Four-Wire) with Addressable Control Modules	45
6.4: CMF-300-6 Installation	46
6.4.1: Cabinet Installation.....	46
6.4.2: Setting an SLC address for an CMF-300-6 Module.....	46
6.4.3: Setting NACs as Style Y or Style Z.....	46
6.4.4: Disabling Unused Module Addresses.....	46
6.4.5: Short Circuit Protection	46
6.4.6: Features Not Supported	46
6.4.7: Circuit Board Information	47
6.5: Wiring a CMF-300-6 Module.....	48
6.5.1: Wiring a Style Y NAC (Two-Wire)	48
6.5.2: Wiring a Style Z NAC (Four-Wire).....	49
Section 7: Relay Modules	50
7.1: Description.....	50
7.2: CRF-300 Installation & Wiring	50
7.2.1: Setting an SLC address for a CRF-300 Module	50
7.2.2: Wiring a CRF-300 Module (Form-C Relay)	50
7.3: CRF-300-6 Circuit Board Information	51
7.4: CRF-300-6 Installation & Wiring.....	52
7.4.1: Cabinet Installation.....	52
7.4.2: Setting an SLC address for a CRF-300-6 Module.....	52
7.4.3: Disabling Unused Module Addresses.....	52
7.4.4: Wiring a CRF-300-6 Module (Form-C Relay).....	52
Section 8: Multiple Input/Output Modules.....	53
8.1: Description.....	53
8.2: CDRM-300 Installation & Wiring	53
8.2.1: Setting an SLC address for a CDRM-300 Module.....	53
8.2.2: Wiring a CDRM-300 Module (Form-C Relay).....	53
Section 9: Intelligent Detector Bases and Wireless Gateway	54
9.1: Description.....	54
9.2: Setting the Detector Address	54
9.3: Wiring a Detector Base.....	55
9.4: Wiring an Isolator Base	56
9.5: Wiring a Relay Base	56
9.6: Wiring a Sounder Base	57
9.7: Wiring the W-GATE	57
9.7.1: SLC Connections.....	58
9.7.2: W-GATE Powered by the SLC	58
9.7.3: W-GATE Powered by a Regulated, External +24VDC Power Source.....	59

Section 10: Addressable Beam Detectors	60
10.1: Description.....	60
10.2: Installation and Wiring	60
10.2.1: Setting an SLC Address for a Beam Detector	60
10.2.2: Wiring a Beam Detector	60
Section 11: Addressable Manual Pull Station.....	62
11.1: Description.....	62
11.2: Installation.....	62
11.2.1: Setting an SLC address.....	62
11.2.2: Wiring a Manual Pull Station	62
Appendix A: Power Considerations	63
A.1: Supplying Power to 24 VDC Detectors and NACs	63
A.1.1: Resistance and Size.....	63
A.2: Supervising 24 VDC Power.....	64
Appendix B: Surge Suppression	65
B.1: Introduction.....	65
B.2: Installation.....	65
B.2.1: Wiring Diagram for MS-9200.....	66
B.2.2: Wiring Diagram for MS-9600, MS-9600LS, MS-9600UDLS, MS-9200UD, MS-9200UDLS, and MS-9050UD	67
B.2.3: Wiring Diagram for ES-50X and ES-200X	68
Appendix C: Terminal Conversion Charts for New & Legacy Devices	69
C.1: CRF-300.....	69
C.2: CMF-300 and MMF-302	69
C.3: MMF-300	70
C.4: MDF-300.....	71
Appendix D: Intelligent Detector Base Layouts for Legacy Devices.....	72
D.1: B350LP or B501 Detector Base.....	72
D.2: B224BI Isolator Base.....	73
D.3: B224RB Relay Base	73
D.4: B501BH(-2) and B501BHT(-2) Sounder Bases	74
Appendix E: Canadian Versions of SLC Devices	75
Index	77

Section 1: Introduction

1.1 Scope

This document describes the operation, installation and wiring of various Signaling Line Circuit (SLC) devices when used with the Fire-Lite MS-9200, MS-9200E, MS-9600, MS-9600E, MS-9600LS, MS-9600LSC, MS-9600LSE, MS-9600UDLS, MS-9600UDLSE, MS-9200UD, MS-9200UDE, MS-9200UDLS, MS-9200UDLSE, MS-9200UDLSC, MS-9050UD, MS-9050UDC, MS-9050UDE, ES-50X, ES-50XC, ES-200X, and ES-200XC control panels. It also provides basic information that applies to Fire•Lite SLC loops in general, such as the branch resistance measurements.



NOTE: Any reference in this manual to the MS-9200, MS-9200UD, MS-9200UDLS, MS-9600, MS-9600LS, MS-9600UDLS, MS-9050UD, ES-50X, or ES-200X includes the MS-9200E, MS-9200UDE, MS-9200UDLSE, MS-9200UDLSC, MS-9600E, MS-9600LSE, MS-9600LSC, MS-9600UDLSE, MS-9050UDC, MS-9050UDE, ES-50XC, or ES-200XC respectively unless otherwise specified.

Additional information about the specific control panel and the modules and detectors referenced in this document can be found in the respective installation manual as listed in Section 1.1.1, “Reference Documentation”.

Currently, there are two styles of modules available, legacy version and newer version. The obvious difference between the two styles is the orientation of the rotary dials. Refer to the diagram below for an example of each.

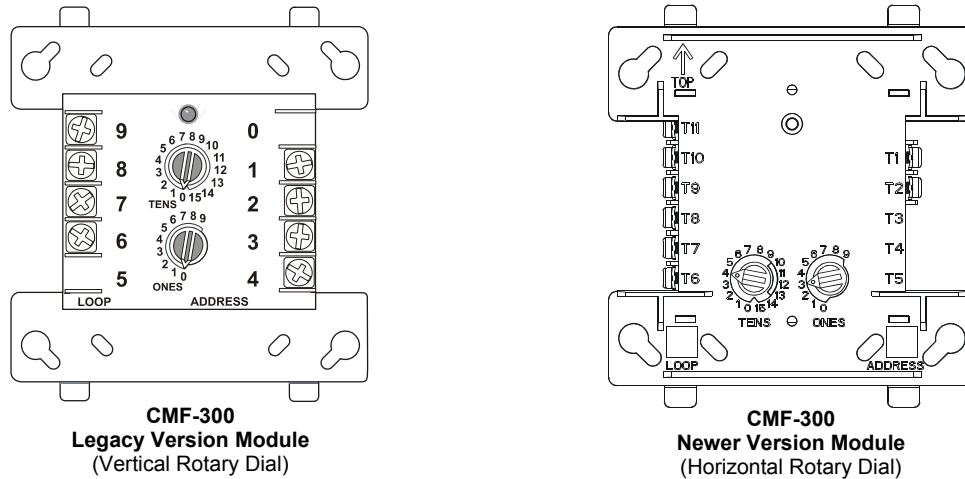

NOTE: Only the **MMF-300**, **MMF-302**, **CRF-300**, **CMF-300**, and **MDF-300** modules are available as newer type modules. Both the legacy and newer versions share the same part numbers. The newer version modules will be phased in, replacing the legacy version. This manual contains information and wiring diagrams for the newer version of the modules. Refer to “Terminal Conversion Charts for New & Legacy Devices” on page 69 for additional information.

Currently, there are two styles of detector bases available, legacy version and newer version. The obvious difference between the two styles is the orientation of the screw terminals. Refer to Section 9 and Appendix D for an illustration of each.



NOTE: Only the B501 Detector Base, B210LP Detector Base (replacement base for B350LP), B224RB Relay Base, and B224BI Isolator Base are available as newer type bases. Both the legacy and newer versions share the same part numbers. The newer version bases will be phased in, replacing the legacy version. This manual contains information and wiring diagrams for the newer version of the bases. Refer to “Intelligent Detector Base Layouts for Legacy Devices” on page 72 for additional information.

1.1.1 Reference Documentation

The table below accommodates a list of document sources containing additional information regarding the devices used on a Signaling Line Circuit:

For information on...	Refer to...	Part Number
MS-9200, MS-9200E	Instruction Manual	51003
MS-9600, MS-9600E	Instruction Manual	51335
MS-9200UD, MS-9200UDE Control Panels	Instruction Manual	51906
MS-9200UDLS, MS-9200UDLSE, MS-9200UDLSC Control Panels	Instruction Manual	52750
MS-9600LS, MS-9600LS(C/E) & MS-9600UDLS, MS9600UDLSE Control Panels	Instruction Manual	52646
MS-9050UD, MS-9050UDC, MS-9050UDE Control Panels	Instruction Manual	52413
ES-50X, ES-50XC Control Panels	Instruction Manual	LS10129-000FL-E
ES-200X, ES-200XC Control Panels	Instruction Manual	LS10131-000FL-E
Compatible Devices	Device Compatibility Document	15384
Wireless Sensor Network	Instruction Manual	LS10036-000FL-E
BG-12LX Pull Station	Installation Instructions	I56-3655
MMF-300 Monitor Module	Installation Instructions	I56-1191 / I56-3653
MMF-300-10 Monitor Module	Installation Instructions	I56-1873

For information on...	Refer to...	Part Number
MMF-301 Mini Monitor Module	Installation Instructions	156-1193 / 156-3654
MMF-302 Monitor Module	Installation Instructions	156-1192 / 156-3652
MMF-302-6 Interface Module	Installation Instructions	156-1900
MDF-300 Dual Monitor Module	Installation Instructions	156-0013 / 156-3665
CMF-300 Control Module	Installation Instructions	156-1189 / 156-3650
CMF-300-6 Control Module	Installation Instructions	156-1874
CRF-300 Relay Module	Installation Instructions	156-1190 / 156-3651
CRF-300-6 Relay Module	Installation Instructions	156-1875
CDRM-300 Multiple Input/Output Module	Installation Instructions	156-3726
I300 Isolator Module	Installation Instructions	156-1381
ISO-6 Isolator Module	Installation Instructions	156-4096
AD350 Multi-criteria Detector	Installation Instructions	F300-17-00
AD355 Multi-criteria Detector	Installation Instructions	156-3660
AD365/-IV Multi-criteria Detector	Installation Instructions	156-6617
AD365A/-IV Multi-criteria Detector	Installation Instructions	156-9140
SD350 & SD350T Photo Detector	Installation Instructions	156-0035
SD355 & SD355T Photo Detector	Installation Instructions	156-3660
SD355CO CO Detector	Installation Instructions	156-4129
SD355R Photo Detector Remote Capable	Installation Instructions	156-3570
SD365CO CO Detector	Installation Instructions	156-6601
SD365/-IV Photo Detector	Installation Instructions	156-6523
SD365T/-IV Photo Detector	Installation Instructions	156-6526
SD365R/-IV Photo Detector Remote Capable	Installation Instructions	156-6524
CP350 Ionization Detector	Installation Instructions	156-0036
CP355 Ionization Detector	Installation Instructions	156-3656
H350 Heat Detector	Installation Instructions	156-0038
H350R Heat Detector w/ROR	Installation Instructions	156-0037
H355 Heat Detector (135°)	Installation Instructions	156-3657
H355R Heat Detector w/ROR	Installation Instructions	156-3657
H355HT Heat Detector (190°)	Installation Instructions	156-3657
H365/-IV Heat Detector (135°)	Installation Instructions	156-6525
H365R/-IV Heat Detector w/ROR	Installation Instructions	156-6525
H365HT/-IV Heat Detector (190°)	Installation Instructions	156-6525
D350P Duct Detector	Installation Instructions	F300-10-00
D350PL(A) Duct Detector - low flow	Installation Instructions	156-1975
D350RP Duct Detector w/Relay	Installation Instructions	156-0047
D350RPL(A) Duct Detector w/Relay - low flow	Installation Instructions	156-1974
D355PL Duct Detector - low flow	Installation Instructions	156-3255
BEAM355(S) Addressable Beam Detector	Installation Instructions	156-2425
OSI-RI-FL Intelligent Beam Detector	Installation Instructions	156-6584
B210LP Plug-in Detector Base	Installation Instructions	156-3739
B501 Legacy Detector Base	Installation Instructions	156-0357
B501, B501-WHITE, B501-IV, and B501-BL Detector Bases	Installation Instructions	156-3738
B501BH Sounder Detector Base	Installation Instructions	156-0491
B501BH-2 Sounder Detector Base	Installation Instructions	156-2813
B501BHT Temporal Sounder Detector Base	Installation Instructions	156-1367
B501BHT-2 Temporal Sounder Detector Base	Installation Instructions	156-2819
B200S-WH, B200S-IV Sounder Detector Bases	Installation Instructions	156-3387
B200S-LF-WH, B200S-LF-IV Low Frequency Sounder Detector Bases	Installation Instructions	156-4151
B200SR-WH, B200SR-IV Sounder Detector Bases	Installation Instructions	156-3392
B200SR-LF-WH, B200SR-LF-IV Low Frequency Sounder Detector Bases	Installation Instructions	156-4152
B224RB Legacy Relay Detector Base	Installation Instructions	156-2815
B224RB-WH, B224RB-IV Relay Detector Bases	Installation Instructions	156-3737
B224BI Isolator Detector Base	Installation Instructions	156-0725
B224BI-WH, B224BI-IV Isolator Detector Bases	Installation Instructions	156-3736
B300-6, B300-6-IV Detector Base	Installation Instructions	156-6566

For information on...	Refer to...	Part Number
SD992 Photo Detector	Installation Instructions	I56-5827
H995 Photo/Thermal Detector	Installation Instructions	I56-5828
MCP900 Addressable Pull Station	Installation Instructions	I56-5833
CMF-900 Control Module	Installation Instructions	I56-5829
MMF-900 Monitor Module	Installation Instructions	I56-5830
MMF-902 Interface Module	Installation Instructions	I56-5831
I900 Isolator Module	Installation Instructions	I56-5832
IO900 Input/Output Module	Installation Instructions	I56-5834
B901 Detector Base	Installation Instructions	I56-1900

1.2 Overview

Communication between the control panel and intelligent addressable monitor and control devices takes place through a Signaling Line Circuit (SLC), which can be wired to meet the requirements of NFPA Style 4, Style 6, or Style 7.

At least one secondary surge protector must be used with each SLC wiring pair whenever SLC wiring runs outside the building. For detailed information refer to “Surge Suppression” on page 65.

1.3 Polling Protocols

The MS-9200UDLS, MS-9600LS, MS-9600UDLS, ES-50X, and ES-200X support LiteSpeed protocol or Classic Loop Interface Protocol (CLIP). The MS-9200/E, MS-9600/E, MS-9200UD/E, and MS-9050UD support Classic Loop Interface Protocol (CLIP) only.

1.3.1 Available Protocols

LiteSpeed is a communication protocol that greatly enhances the speed of communication between analog intelligent devices. Only the MS-9200UDLS, MS-9600LS, MS-9600UDLS, ES-50X, and ES-200X are capable of operating in LiteSpeed mode. This is the default mode of operation for these FACP's.

CLIP (Classic Loop Interface Protocol) polls devices in sequential order. All Fire-LiteFireWarden addressable fire alarm control panels can operate in CLIP mode. This is the default mode of operation for all other FACP's.

1.3.2 Protocol Use

Use one of the following options with LiteSpeed/CLIP mode:

1. Program all modules and detectors on an FACP as LiteSpeed.
2. Program all modules and detectors on an FACP as CLIP.



NOTE: FACP's with more than one SLC loop must be programmed for only LiteSpeed or CLIP mode of operation. Communication protocols cannot be split between SLC loops.

When switching between polling protocols, the loop circuit must be powered down for at least 30 seconds to reset the devices.

1.4 Devices

1.4.1 Isolator Modules

Isolator Modules permit a zone of detectors and modules to be fault isolated from the remainder of the SLC loop, allowing critical components to function in the event of a circuit fault. Isolator modules are required to meet the requirements of an NFPA Style 7 circuit.

I300 - Single fault isolator module

ISO-6 - Six fault isolator module

1.4.2 Monitor Modules

Addressable modules that allow the control panel to monitor entire circuits of conventional alarm initiating devices, such as manual pull stations, smoke detectors, heat detectors, waterflow and supervisory devices.

MMF-300 - Monitors a Style B (Class B) or Style D (Class A) circuit of dry-contact input devices.

MMF-300-10 - Monitors ten (10) Style B (Class B) or five (5) Style D (Class A) normally open contact device circuits.

MMF-301 - Same as the **MMF-300** except offered in a smaller package for mounting with Style B wired devices. This module does not have an LED.

MMF-302 - Monitors a single IDC of two-wire smoke detectors.

MMF-302-6 - Addressable module that provides an interface between the control panel and six (6) Style B (Class B) or three (3) Style D (Class A) IDCs of two-wire smoke detectors.

MDF-300 - Similar to **MMF-300**, but provides for two independent Style B IDCs.

1.4.3 Control Modules

Through the **CMF-300** addressable control module, the control panel can selectively activate a Notification Appliance Circuit (NAC).

CMF-300-6 - Similar in operation to the CMF-300, except it can activate six (6) Style Y (Class B) or three (3) Style Z (Class A) NACs.

1.4.4 Relay Modules

The **CRF-300** addressable relay module provides the control panel with a dry-contact output for activating a variety of auxiliary devices.

CRF-300-6 - Similar in operation to the CRF-300, except it provides six (6) Form-C relays.

1.4.5 Multiple Input/Output Modules

The **CDRM-300** addressable multiple input/output module monitors two (2) Style B input devices and provides two (2) independent Form-C relay contacts.

1.4.6 Intelligent Detectors

AD350 - A multi-criteria smoke sensor that combines a photoelectric sensing chamber and 135°F (57.2°C) fixed temperature heat detection. The sensor uses addressable communication to transmit smoke density and other information to the control panel. It adjusts its detection parameters and alarm threshold depending on the ambient conditions it samples in its environment.

AD355 - Multi-criteria smoke sensor that combines a photoelectric sensing chamber and 135°F (57.2°C) fixed temperature heat detection. The sensor uses addressable communication to transmit smoke density and other information to the control panel. It adjusts its detection parameters and alarm threshold depending on the ambient conditions it samples in its environment.

AD365 - Multi-criteria smoke sensor that combines a photoelectric sensing chamber and 135°F (57.2°C) fixed temperature heat detection. The sensor uses addressable communication to transmit smoke density and other information to the control panel. It adjusts its detection parameters and alarm threshold depending on the ambient conditions it samples in its environment. This model is available in ivory with -IV added to the model name. The ivory color model has the ability to work in CLIP mode. The standard white color functions in LiteSpeed only. This device is only listed for UL 268 6th Edition requirements.

CP350 - An addressable ionization smoke detector which measures the level of combustion products in its chamber using the 'ionization principle'.

CP355 - Addressable ionization smoke detector which measures the level of combustion products in its chamber using the 'ionization principle'.

D350P - An addressable photoelectric duct detector. The **D350RP** includes an alarm relay. Air velocity rating is 500 to 4,000 feet per minute.

D350PL - Addressable low flow photoelectric duct detector (**D350PLA** for Canada). The **D350RPL** includes an alarm relay (**D350RPLA** for Canada). Low Flow refers to the air velocity rating of 100 to 4,000 feet per minute (0.5 to 20.32 m/sec).

D355PL - An addressable non-relay photoelectric low flow smoke detector. Low Flow refers to the air velocity rating of 100 to 4,000 feet per minute (0.5 to 20.32 m/sec).

H350¹ - An addressable detector using a thermistor sensing circuit for fast response. **H350R** incorporates a thermal rate of rise of 15°F (9.4°C)/minute.

H355¹ - Addressable 135° fixed temperature heat detector using a thermistor sensing circuit for fast response. **H355R** incorporates a thermal rate of rise of 15° F (9.4° C)/minute.

H355HT¹ - Addressable 190° fixed temperature heat detector using a thermistor sensing circuit for fast response.

H365¹ - Addressable 135° fixed temperature heat detector using a thermistor sensing circuit for fast response. **H365R** incorporates a thermal rate of rise of 15° F (9.4° C)/minute. This model is available in ivory with -IV added to the model name. The ivory color model has the ability to work in CLIP mode. The standard white color functions in LiteSpeed only.

H365HT¹ - Addressable 190° fixed temperature heat detector using a thermistor sensing circuit for fast response. This model is available in ivory with -IV added to the model name. The ivory color model has the ability to work in CLIP mode. The standard white color functions in LiteSpeed only.

SD350 - An addressable photoelectric smoke detector which provides smoke sensing utilizing optical sense technology. The **SD350T** includes a 135° F fixed thermal sensor.

SD355 - Addressable photoelectric smoke detector which provides smoke sensing utilizing optical sense technology. The **SD355T** includes a 135° F fixed thermal sensor. The **SD355R** is a low profile, intelligent, photoelectric sensor that is remote test capable.

SD365 - Addressable photoelectric smoke detector which provides smoke sensing utilizing optical sense technology. The **SD365T** includes a 135° F fixed thermal sensor. The **SD365R** is a low profile, intelligent, photoelectric sensor that is remote test capable. For use with DNR(W). This model is available in ivory with -IV added to the model name. The ivory color model has the ability to work in CLIP mode. The standard white color functions in LiteSpeed only.

SD355CO - addressable device that provides both fire and carbon monoxide (CO) detection. It combines four separate sensing elements in one unit (smoke, CO, light/flame, and heat) to sense multiple components of a fire. The detector's electrochemical sensing cell creates a separate signal for life safety CO detection.

SD365CO - addressable device that provides both fire and carbon monoxide (CO) detection. It combines four separate sensing elements in one unit (smoke, CO, light/flame, and heat) to sense multiple components of a fire. The detector's electrochemical sensing cell creates a separate signal for life safety CO detection. This model functions in LiteSpeed only. This device is only listed for UL 268 6th Edition requirements.

1. Addressable Heat Detectors are not compatible with the MS-9200(E).

BEAM355 - An addressable long range projected beam smoke detector designed to provide open area protection. The **BEAM355S** has an integral sensitivity test feature that consists of a test filter attached to a servomotor inside the detector optics.

DNR(W) - Innovair Flex, intelligent, non-relay, low flow, photoelectric duct detector housing. This requires the SD355R or SD365R photoelectric smoke detector. Accommodates the installation of the CRF-300 relay module. The **DNRW** is a watertight housing.

OSI-RI-FL - An addressable long range projected beam smoke detector designed to provide open area protection. Operates in LiteSpeed or CLIP mode.

1.4.7 Manual Pull Station

The **BG-12LX** is a dual-action pull station that, when activated, provides an addressable identification and its location to the control panel. An addressable monitor module is mounted inside the pull station to facilitate servicing and replacement.

1.4.8 Wireless Gateway

W-GATE: The Wireless Gateway acts as a bridge between a group of wireless fire devices and a LiteSpeed SLC loop on the ES-50X, ES-200X, or MS-9200UDLS. It is powered by the SLC loop or by a regulated, external 24VDC UL listed power supply. Available wireless devices include a photo detector, a photo/heat detector, a fixed-temperature heat detector, a rate-of-rise heat detector, and a monitor module. For details about wireless devices, system setup, and operation, see the *SWIFT™ Smart Wireless Integrated Fire Technology Instruction Manual*.



NOTE: The W-GATE, as part of the wireless network, has been tested for compliance with the Federal Communications Commission (FCC) requirements of the United States Government. It has not been evaluated for use outside the USA. Use of this system outside the USA is subject to local laws and rules to which this product may not conform. It is the sole responsibility of the user to determine if this product may be legally used outside the USA.

1.4.9 300 Series Addressable Devices

Fire•Lite's 300 Series of addressable devices are fully compatible with the MS-9200, MS-9200UD, MS-9200UDLS, MS-9600, MS-9600LS(C/E), MS-9600UDLS/E, MS-9050UD, ES-50X, and ES-200X FACPs. The devices must be configured for CLIP (Classic Loop Interface Protocol) Mode operation. The address of 300 series devices cannot be set above 99. Compatible devices include:

- SD300 Photo
- SD300T Photo w/Thermal
- CP300 Ionization
- BG-10LX Pull Station
- M300 Monitor Module
- M301 Mini Monitor Module
- M302 2-wire Monitor Module
- C304 Control/Relay Module

1.4.10 900 Series Addressable Devices

Fire•Lite's 900 Series of addressable devices are fully compatible with the MS-9200UDLS/E and MS-9050UD/E FACPs, however they are *not for use in the United States or Canada*. The devices must be configured for CLIP (Classic Loop Interface Protocol) Mode operation. The address of 900 series devices cannot be set above 99. Compatible devices include:

- SD992 Photo
- H995 Photo w/Thermal
- MCP900 Call Point/Pull Station
- CMF-900 Control Module
- B901 Base
- MMF-900 Monitor Module
- MMF-902 Interface Module
- I900 Isolator Module
- IO900 Input/Output Module
- CP900 Programming Tool

Refer to the manufacturer's installation instructions for information on wiring and programming.

1.5 SLC Capacity

The protocol selected for an SLC loop determines the maximum number of devices that can be handled by the loop. See Section 1.3, "Polling Protocols". Within those limits, the individual control panel may have additional restrictions. See the specific installation manual for this information.

1.6 SLC Performance

SLC performance depends on the type of circuit (Style 4, Style 6, or Style 7) and the components on the circuit.



NOTE: SLC operation meeting Style 7 requirements isolates each device on the SLC from faults that may occur within other areas of the SLC.

Wiring style requirements are determined by national and local codes. Consult with the Authority Having Jurisdiction before wiring the SLC. The table below (derived from NFPA 72-1999) lists the trouble conditions that result when a fault exists on an SLC.

Type of Fault	Style 4	Style 6	Style 7
Single Open	Trouble	Alarm, Trouble	Alarm, Trouble
Single Ground	Alarm, Trouble (ground)	Alarm, Trouble (ground)	Alarm, Trouble (ground)
Short	Trouble	Trouble	Alarm, Trouble
Short and open	Trouble	Trouble	Trouble
Short and ground	Trouble	Trouble	Alarm, Trouble
Open and ground	Trouble	Alarm, Trouble	Alarm, Trouble
Communications loss	Trouble	Trouble	Trouble
<ul style="list-style-type: none"> • Trouble - The control panel will indicate a trouble condition for this type of fault. • Alarm - The control panel must be able to process an alarm input signal in the presence of this type of fault. 			

Table 1.1 SLC Performance

1.7 Surge Suppression

One primary surge protector must be used with each SLC wiring pair whenever SLC wiring runs outside the building. For detailed information refer to “Surge Suppression” on page 65.

1.8 LED Operation

The table below lists the LED operation on the various devices on an SLC.

Device	Standby	Activated
Monitor Module	Blinks RED	Steady RED
Control Module	Blinks GREEN	Steady GREEN
Detector	Blinks RED	Steady RED

Table 1.2 LED Operation

Section 2: Wiring Requirements

2.1 Wire Sizing

The SLC requires use of a specific wire type, depending on the mode of operation, to ensure proper circuit functioning. Wire size should be no smaller than 18 AWG (0.75 mm²) and no larger than 12 AWG (3.25 mm²) wire. The wire size depends on the length of the SLC circuit. It is recommended that all SLC wiring be twisted-pair to minimize the effects of electrical interference.

2.1.1 CLIP (Classic Loop Interface Protocol) Mode

All addressable FACP's can operate in CLIP (Classic Loop Interface Protocol) mode. It is recommended that all SLC wiring be twisted-pair and shielded when operating in CLIP mode to reduce the effects of electrical interference. Use the table below to determine the specific wiring requirements for the SLC.

Wire Requirements	Distance in Feet (meters)	Wire Size	Wire Type
Twisted-pair, shielded	10,000 feet (3,048 m)	12 AWG (3.1 mm ²)	Belden 9583, Genesis 4410, Signal 98230, WPW D999
	8,000 feet (2,438 m)	14 AWG (2.0 mm ²)	Belden 9581, Genesis 4408, Signal 98430, WPW D995
	4,875 feet (1,486 m)	16 AWG (1.3 mm ²)	Belden 9575, Genesis 4406, & 4606, Signal 98630, WPW D991
	3,225 feet (983 m)	18 AWG (0.75 mm ²)	Belden 9574, Genesis 4402 & 4602, Signal 98300, WPW D975
Untwisted, unshielded wire, inside conduit or not in conduit	MS-9200 = 1,000 feet (305 m)	12 to 18 AWG	
	MS-9600, MS-9600LS(C) & MS-9600UDLS = 3,000 feet (914 m)		
	MS-9200UD & MS-9200UDLS = 3,000 feet (914 m)		
	MS-9050UD = 3,000 feet (914 m)		
	ES-50X & ES-200X = 3,000 feet (914 m)		

Table 2.1 SLC Wiring Requirements in CLIP Mode

2.1.2 LiteSpeed Mode

The ES-50X, ES-200X, MS-9200UDLS, MS-9600LS, and MS-9600UDLS SLC can be programmed to operate in LiteSpeed mode for a quicker device response time. While shielded wire is not required, it is recommended that all SLC wiring be twisted-pair to minimize the effects of electrical interference. Use the following table to determine the specific wiring requirements for the SLC.

Wire Requirements	Distance in Feet (meters)	Wire Size	Wire Type
Twisted-pair, unshielded	10,000 feet (3,048 m)	12 AWG (3.1 mm ²)	Belden 5020UL & 6020UL, Genesis WG-4315 & WG-4515
	8,000 feet (2,438 m)	14 AWG (2.0 mm ²)	Belden 5120UL & 6120UL, Genesis WG-4313 & WG-4513
	4,875 feet (1,486 m)	16 AWG (1.3 mm ²)	Belden 5220UL & 6220UL, Genesis WG-4311 & WG-4511
	3,225 feet (983 m)	18 AWG (0.75 mm ²)	Belden 5320UL & 6320UL, Genesis WG-4306 & WG-4506

Table 2.2 SLC Wiring Requirements in LiteSpeed Mode

2.2 Measuring Resistance & Length

2.2.1 Two-Wire SLC - Style 4 (Class B)

Loop Resistance

T-tapping of the SLC wiring is permitted for 2-wire Style 4 configurations. The total DC resistance from the control panel to each branch end cannot exceed 40 ohms. Measure DC resistance as detailed and shown below:

1. With power removed, short the termination point of one branch at a time and measure the DC resistance from the beginning of the SLC to the end of that particular branch.

- Repeat this procedure for all remaining branches in the SLC.

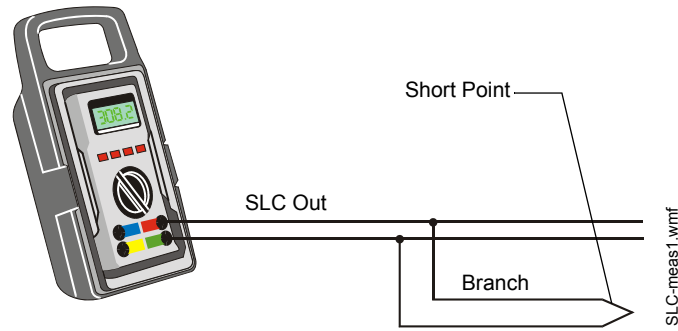

Figure 2.1 Measuring DC Resistance of a Two-Wire SLC

Total Wire Length

The total wire length of all combined branches of one SLC cannot exceed the limits set forth in each system’s instruction manual. Determine the total length in each SLC by summing the wire lengths of all branches of one SLC.

In the following figure, the total length of the SLC is determined by adding the lengths of Branch A plus Branch B plus Branch C.

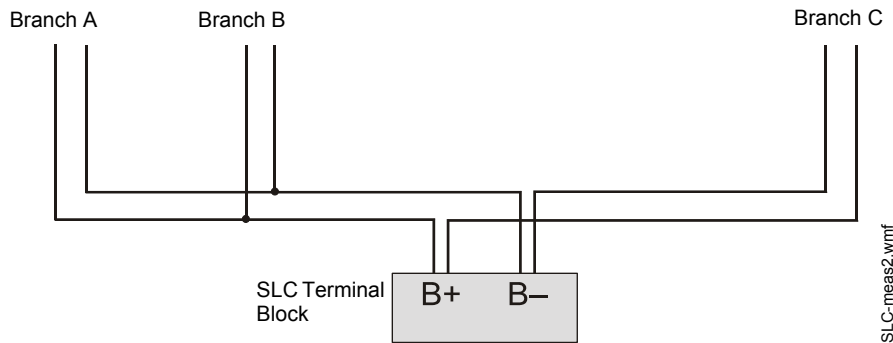

Figure 2.2 Measuring the Total Wire Length - Two-Wire SLC

2.2.2 Four-Wire SLC Style 6 & 7 (Class A)

Loop Resistance

The total DC resistance of the SLC pair cannot exceed 40 ohms. Measure DC resistance as detailed and shown below.

- Disconnect the SLC channel B (Out) and SLC channel A (Return) at the control panel.
- Short the two leads of SLC channel A (Return).
- Measure the resistance across the SLC channel B (Out) leads.

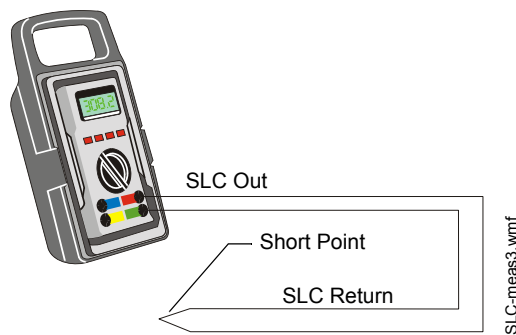

Figure 2.3 Measuring DC Resistance of a Four-Wire SLC

Total Wire Length

The total wire length in a four-wire SLC cannot exceed the limits set forth in each system’s instruction manual. The figure below identifies the output and return loops from SLC terminal on the control panel:

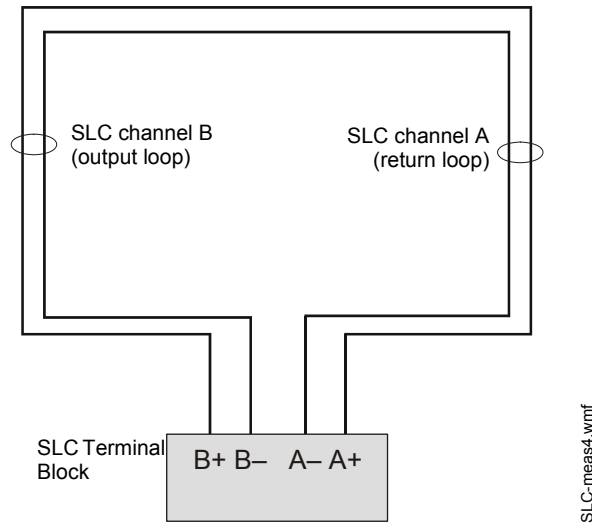

Figure 2.4 Measuring the Wire Length – Four-Wire SLC

2.3 Shield Wire Termination

The drawing below shows the method of proper termination of the shield.

Connect the metal conduit to the cabinet by using the proper connector. Feed the shielded wire through the conduit, into the control box. The shield drain wire must be connected to the “shield” terminal on the SLC terminal block.



NOTE: Use of good wiring practice consistent with local electrical codes is expected.



CAUTION:

DO NOT LET THE SHIELD DRAIN WIRE OR THE SHIELD FOIL TOUCH THE SYSTEM CABINET OR BE CONNECTED TO EARTH GROUND AT ANY POINT.

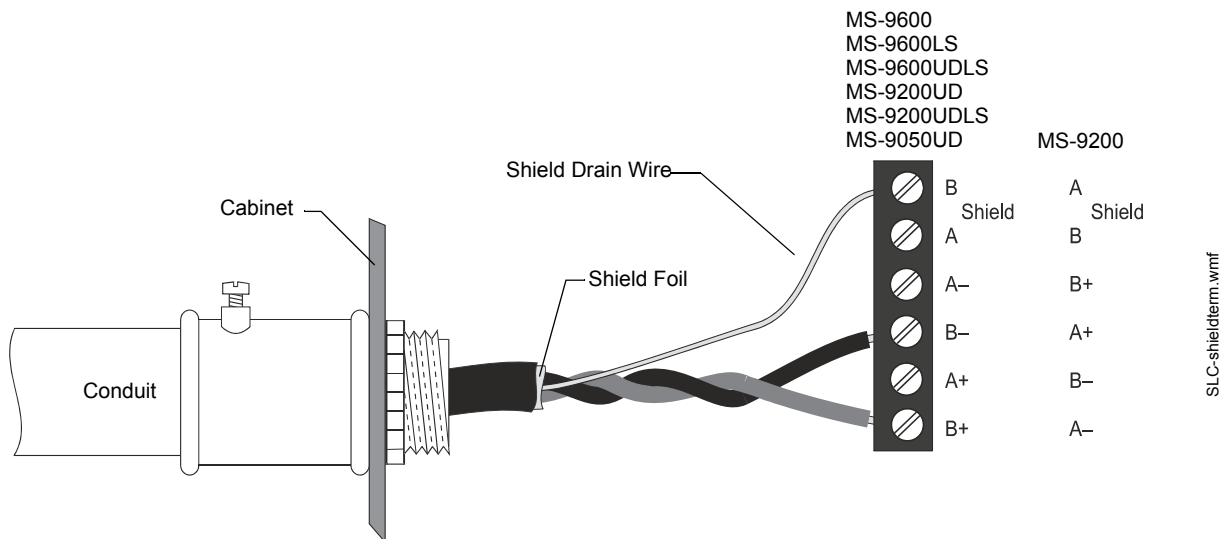

Figure 2.5 Shield Termination

2.4 Control Panel Terminal Blocks

The terminal blocks on the control panel circuit board that concern the SLC circuit are described below. For more information on this subject refer to the control panel's Instruction Manual.

2.4.1 MS-9200

TB4 provides three types of 24 VDC power; Unregulated, Nonresettable and Resettable.

TB6 provides connections for the SLC wiring.

198 addresses are available per loop (99 detectors and 99 modules).

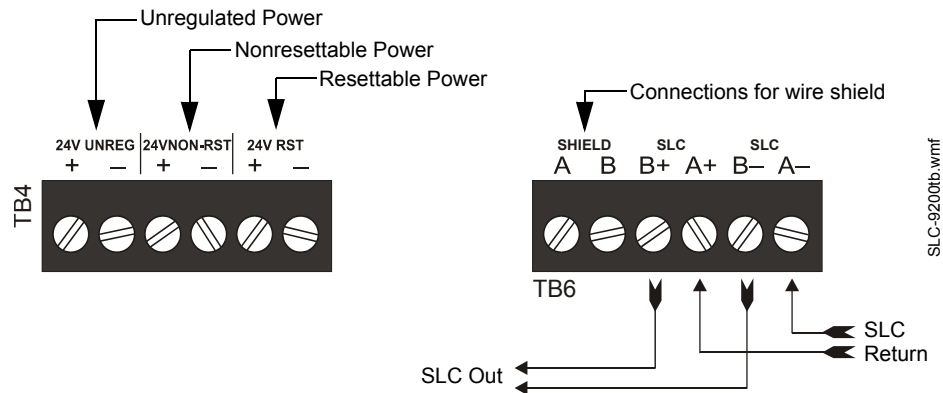

Figure 2.6 MS-9200 Terminal Blocks

2.4.2 MS-9600, MS-9600LS, & MS-9600UDLS

TB3 provides two types of 24 VDC power; Nonresettable and Resettable.

TB8 provides connections for the SLC wiring.

198 addresses are available per loop (99 detectors and 99 modules) while operating in CLIP mode. 318 addresses are available per loop (159 detectors and 159 modules) while operating in LiteSpeed mode.

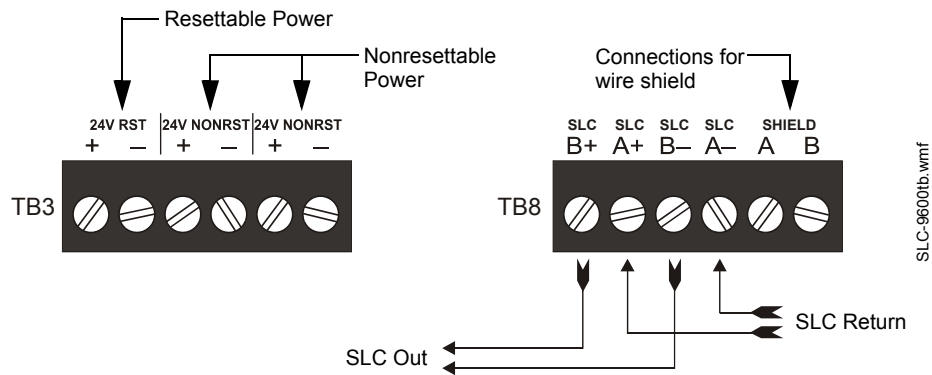

Figure 2.7 MS-9600 Series Terminal Blocks

2.4.3 MS-9200UDLS (Software Version 3.0)

TB1 provides two types of 24 VDC power; Nonresettable and Resettable, jumper selectable by JP4 and JP6.
 TB10 provides connections for the SLC wiring.
 198 addresses are available per loop (99 detectors and 99 modules).

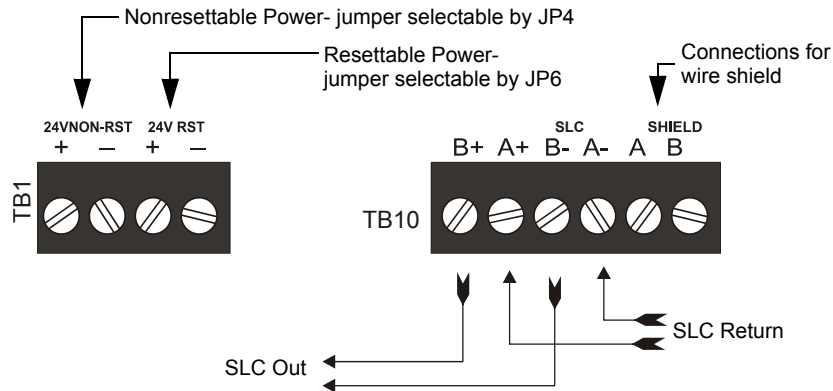

Figure 2.8 MS-9200UDLS (Rev 3) Terminal Blocks

SLC-9200udtb.wmf

2.4.4 MS-9200UD & MS-9200UDLS (Versions 1 and 2)

TB1 provides two types of 24 VDC power; Nonresettable and Resettable.
 TB10 provides connections for the SLC wiring.
 198 addresses are available per loop (99 detectors and 99 modules).

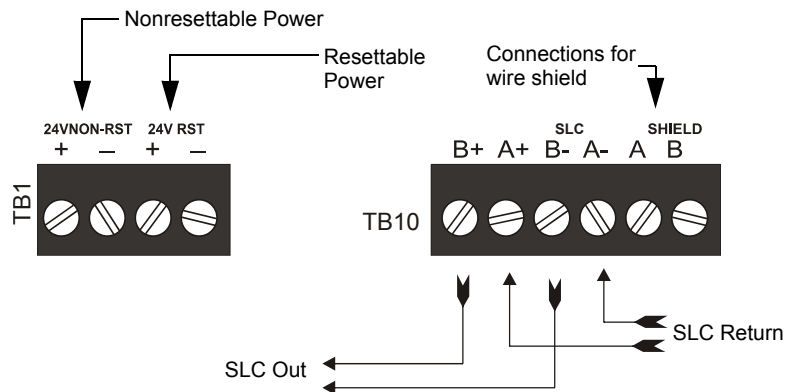

Figure 2.9 MS-9200UD & MS-9200UDLS (Rev 1 & 2) Terminal Blocks

SLC-9200udtb.wmf

2.4.5 MS-9050UD

24 VDC power may be supplied by a remote power supply such as the Fire-Lite FCPS-24FS6/8.
 TB2 provides connections for the SLC wiring.
 50 addresses are available (any combination of detectors and modules).

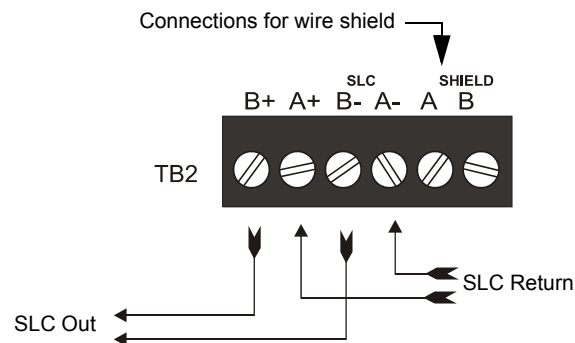

Figure 2.10 MS-9050UD Terminal Block

SLC-9050udtb.wmf

2.4.6 ES-50X

TB11 provides two types of 24 VDC power; Nonresettable and Resettable, user programmable.
 TB12 provides connections for the SLC wiring.
 50 addresses are available (any combination of detectors and modules).

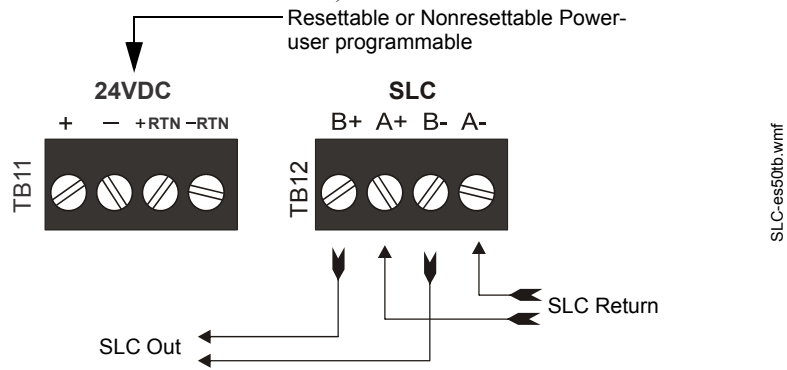

Figure 2.11 ES-50X Terminal Block

2.4.7 ES-200X

TB11 provides two types of 24 VDC power; Nonresettable and Resettable, user programmable. PWR1 has a user programmable Class A wiring option.
 TB12 provides connections for the SLC wiring.
 198 addresses are available per loop (99 detectors and 99 modules).

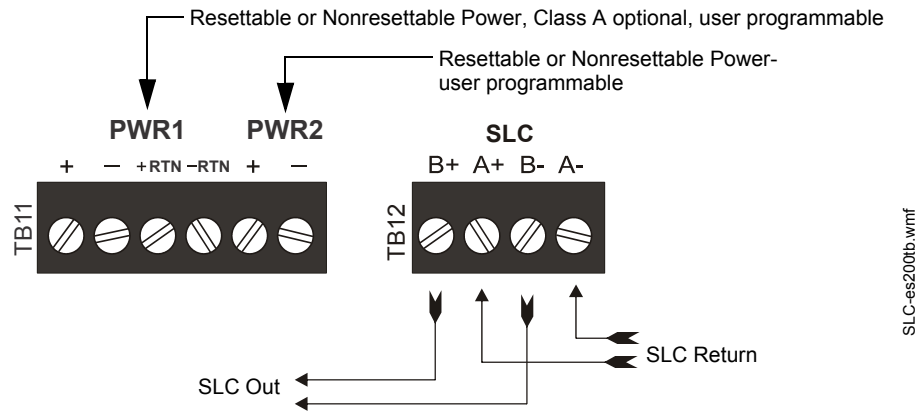

Figure 2.12 ES-200X Terminal Blocks

Section 3: SLC Circuits without Isolators

3.1 Overview

This chapter concerns itself with the two styles of circuits that do not require isolation devices:

- NFPA Style 4
- NFPA Style 6

3.2 NFPA Style 4 SLC

NFPA Style 4 requirements can be met by using the diagram below.

- T-tapping of the SLC wiring is allowed for Style 4 configuration.

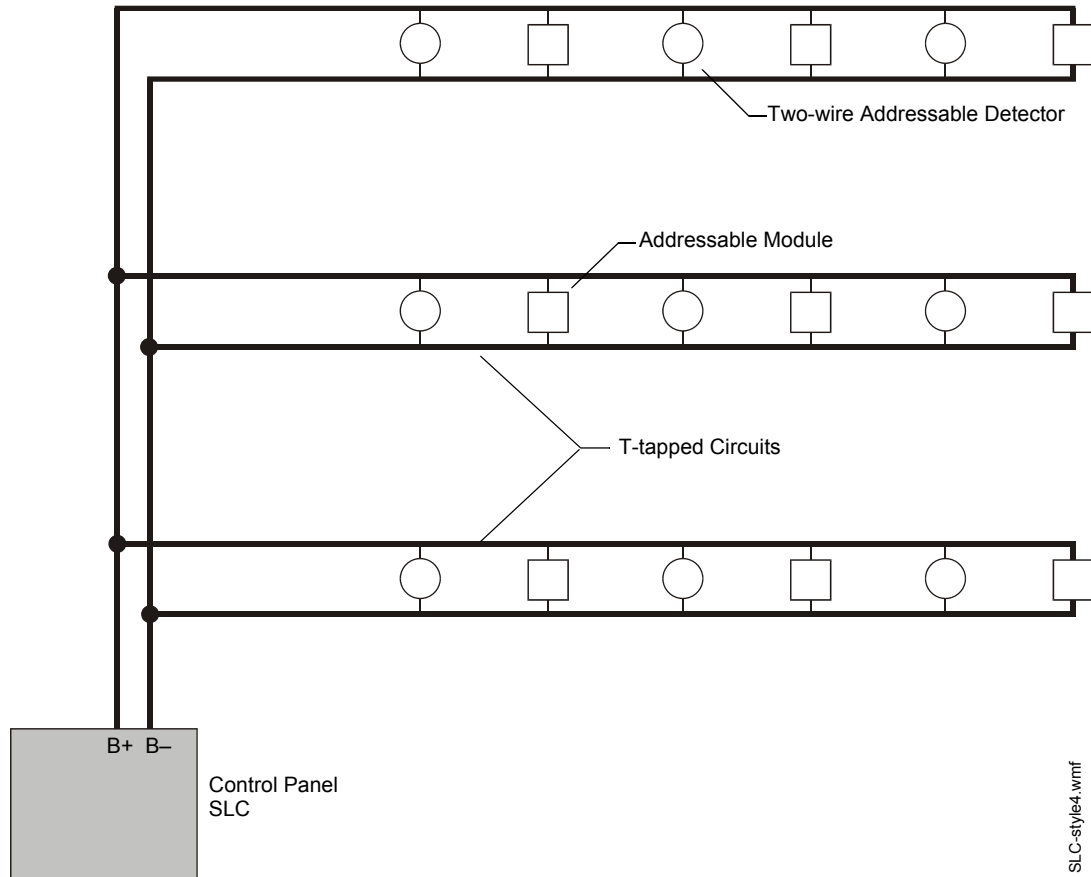

Figure 3.1 Basic NFPA Style 4 SLC

3.3 NFPA Style 6 SLC

NFPA Style 6 requirements can be met by using the diagram below.

- T-tapping of the SLC wiring is NOT allowed for Style 6 configuration.

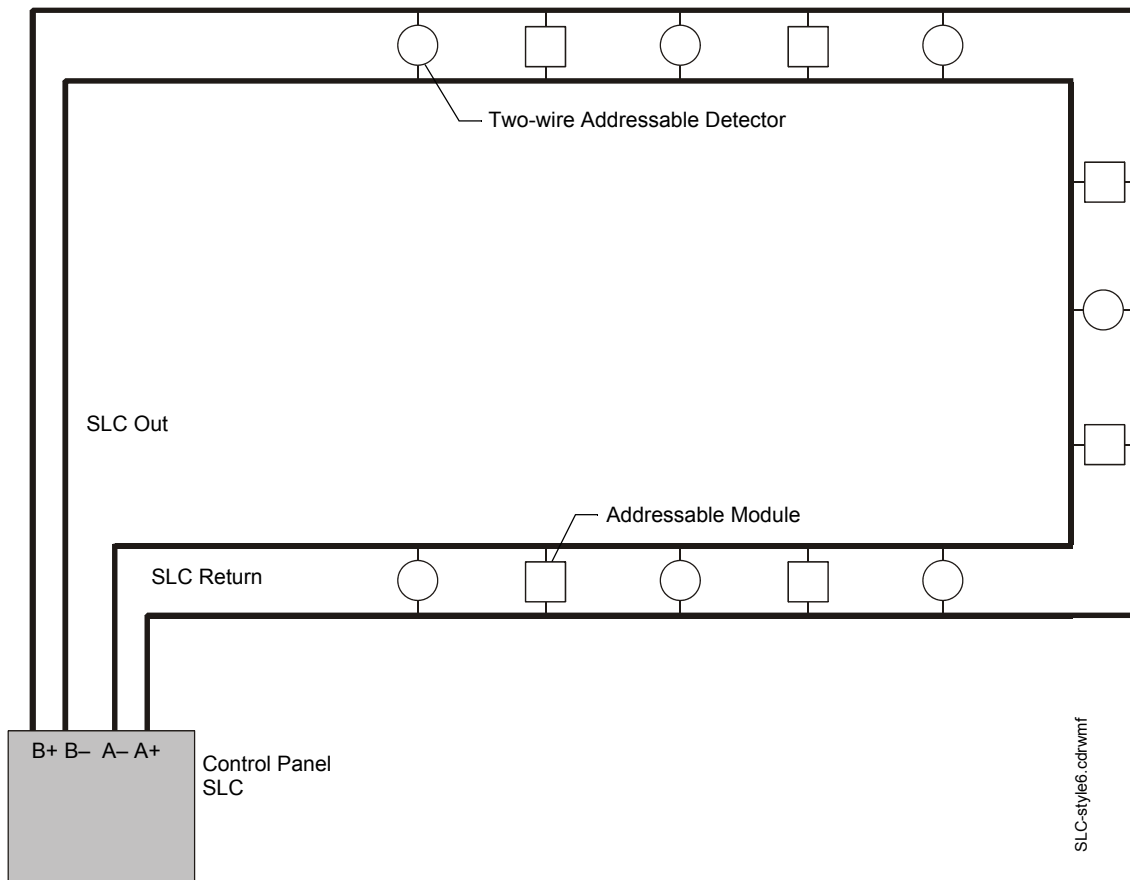

Figure 3.2 Basic NFPA Style 6 SLC

Section 4: SLC Circuits with Isolators

4.1 Fault Isolator Devices

There are three isolator devices used to protect critical elements of the SLC from faults on other SLC branches or segments.

- Fault Isolator Module **I300**
- Six Fault Isolator Module **ISO-6**
- Isolator Detector Base **B224BI**

A Fault Isolator Module on both sides of a device, or the combination of Isolator Base and Isolator Module is required to comply with NFPA Style 7 requirements.



CAUTION: MAXIMUM ADDRESSABLE DEVICES

- If relay or sounder bases are not used, a maximum of 25 addressable devices can be connected between Isolator Modules and/or Bases. When relay or sounder bases are used, the maximum number of addressable devices that can be connected between Isolators is reduced to seven. Isolator modules will not function properly when these limits are exceeded.
- When more than 100 Isolator Modules are connected to an SLC loop, the address capacity of the loop is reduced by two (2) addresses for every isolator device in excess of 100.

4.1.1 Isolating an SLC Branch

The module continuously monitors the circuit connected to terminals 3(-) and 4(+). Upon power-up, an integral relay is latched on. The module periodically pulses the coil of this relay. A short circuit on the SLC resets the relay. The module detects the short and disconnects the faulted SLC branch or segment by opening the positive side of the SLC (terminal 4). This isolates the faulty branch from the remainder of the loop preventing a communication problem with all other addressable devices on the remaining branches (labeled “Continuation of the SLC” in the figure below). During a fault condition, the control panel registers a trouble condition for each addressable device which is isolated on the SLC segment or branch. Once the fault is removed, the module automatically reapplies power to the SLC branch or segment.

4.1.2 Wiring an Isolator Module

The figure below shows typical wiring of an I300 Isolator Module:

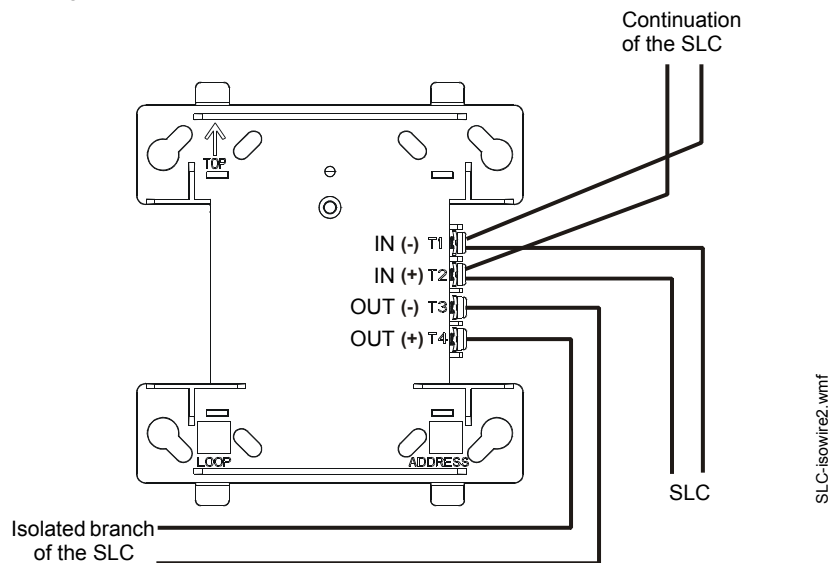

Figure 4.1 Wiring an I300 Module

The figure below shows typical wiring of an ISO-6 Isolator Module:

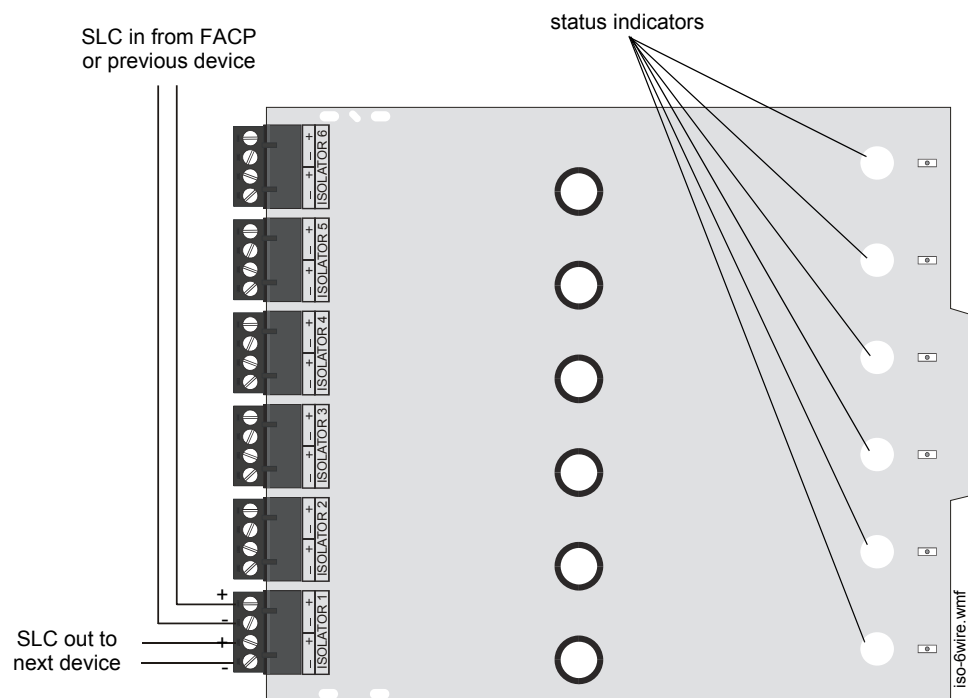

Figure 4.2 Wiring an ISO-6 Module

4.2 NFPA Style 4 SLC Using Isolator Modules

A variation of a Style 4 operation using an I300 isolator module to protect each branch of the SLC is shown below. Refer to Figure 4.1 for I300 wiring and to Section 4.1 for limitations.

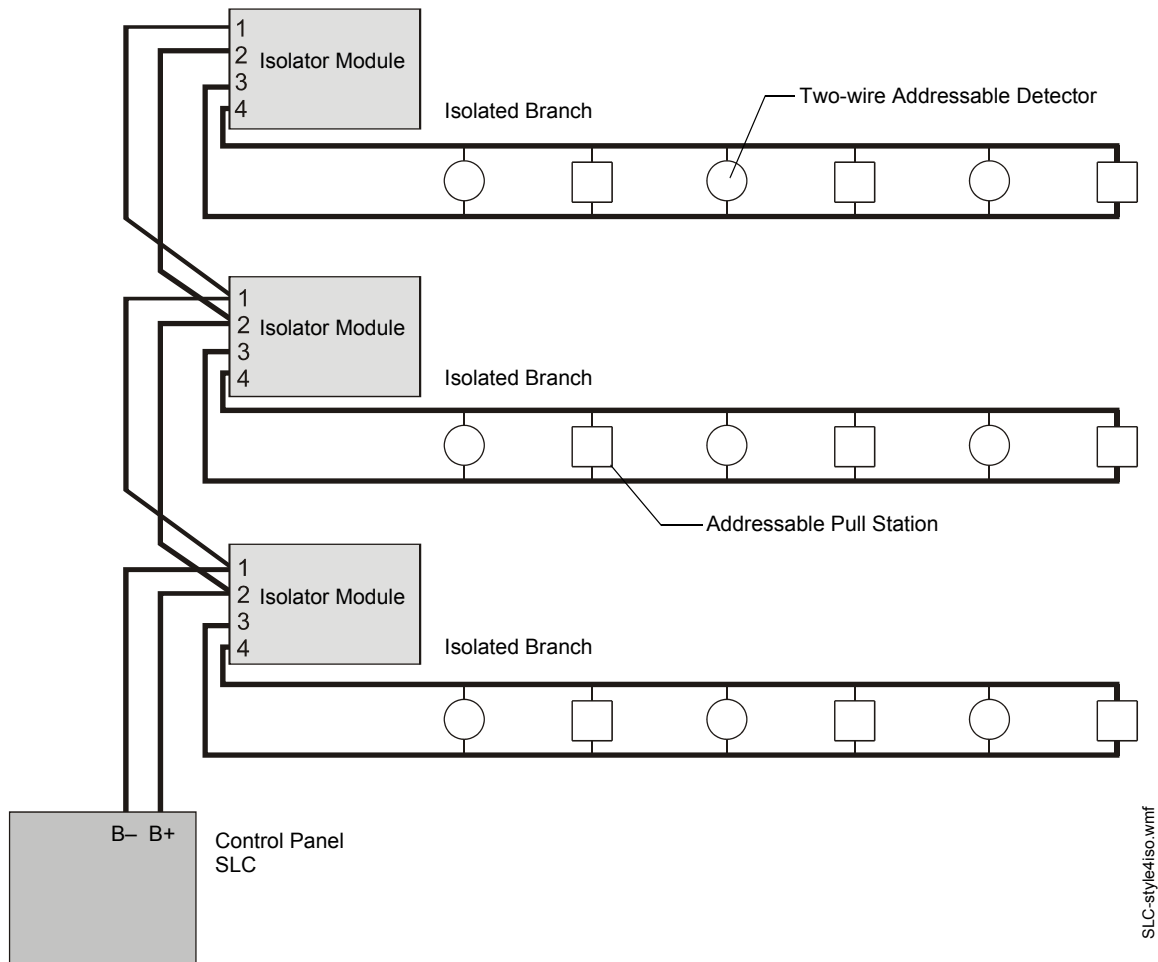

Figure 4.3 NFPA Style 4 SLC Using an I300 Isolator Module

A variation of a Style 4 operation using an ISO-6 isolator module to protect each branch of the SLC is shown below. Each terminal on the ISO-6 acts as a single I300 module. Refer to Figure 4.2 for ISO-6 wiring and to Section 4.1 for limitations. Note that the ISO-6 cannot accept two wires at one pin. Wire Style 4 SLC loops as shown in the figure below.

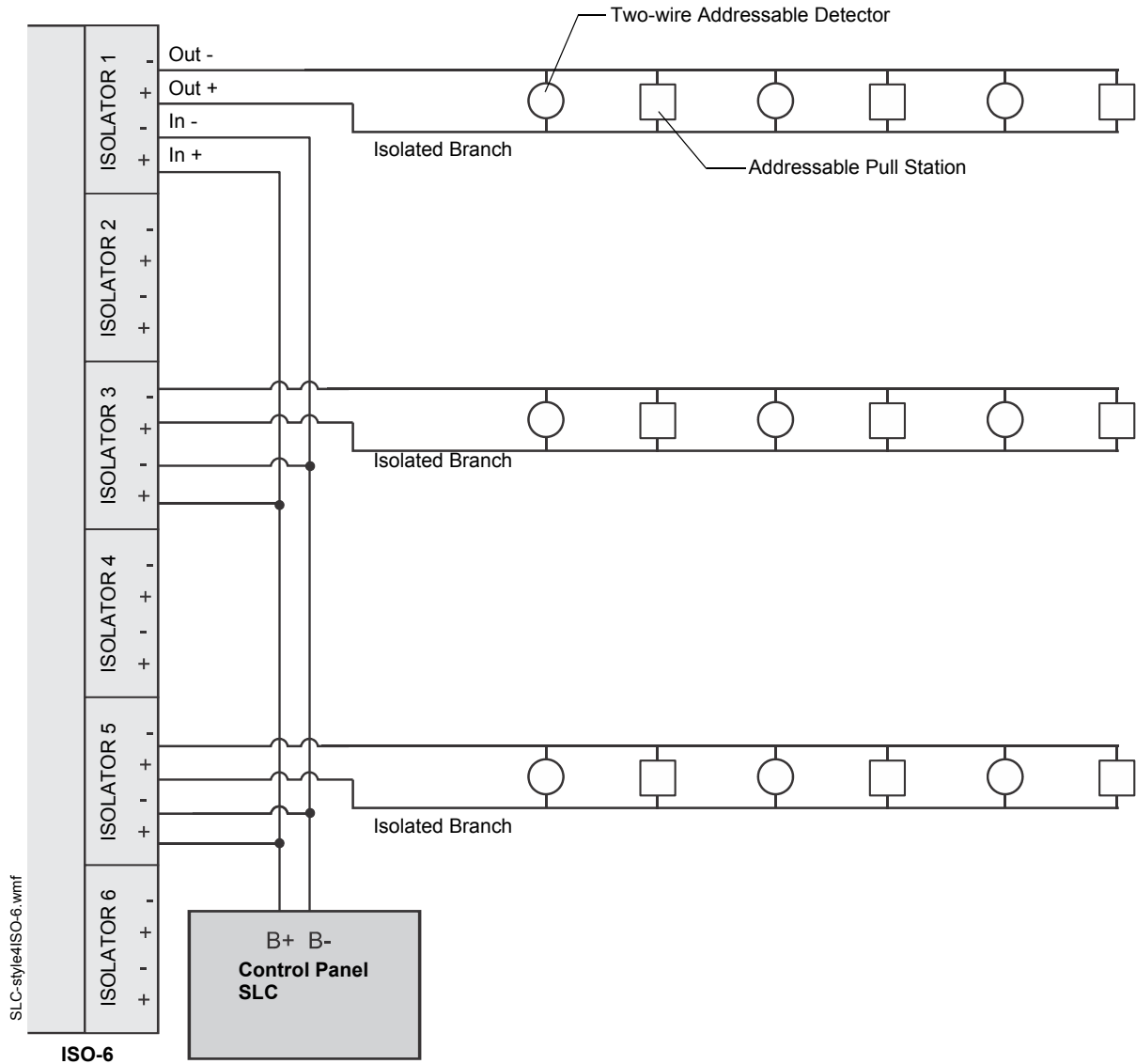

Figure 4.4 NFPA Style 4 SLC Using an ISO-6 Isolator Module

4.3 NFPA Style 6 SLC Using Isolator Modules

A variation of Style 6 operation using isolator modules to protect a section of the SLC. By flanking each group of devices with an I300 fault isolator module, each group is protected from faults that may occur in the other groups. For example, a fault in Section B will not effect Sections A & C. The isolator modules on either side of Section B will open the loop. Section A will still operate from power on the SLC Out side and Section C will operate from the SLC Return side.

- A combination of isolator modules and isolator bases may be used.
- T-tapping is NOT allowed within the Style 6 configuration.
- Isolator modules shall be within 20 feet (6.1 meters) of device and must be enclosed in metal conduit.

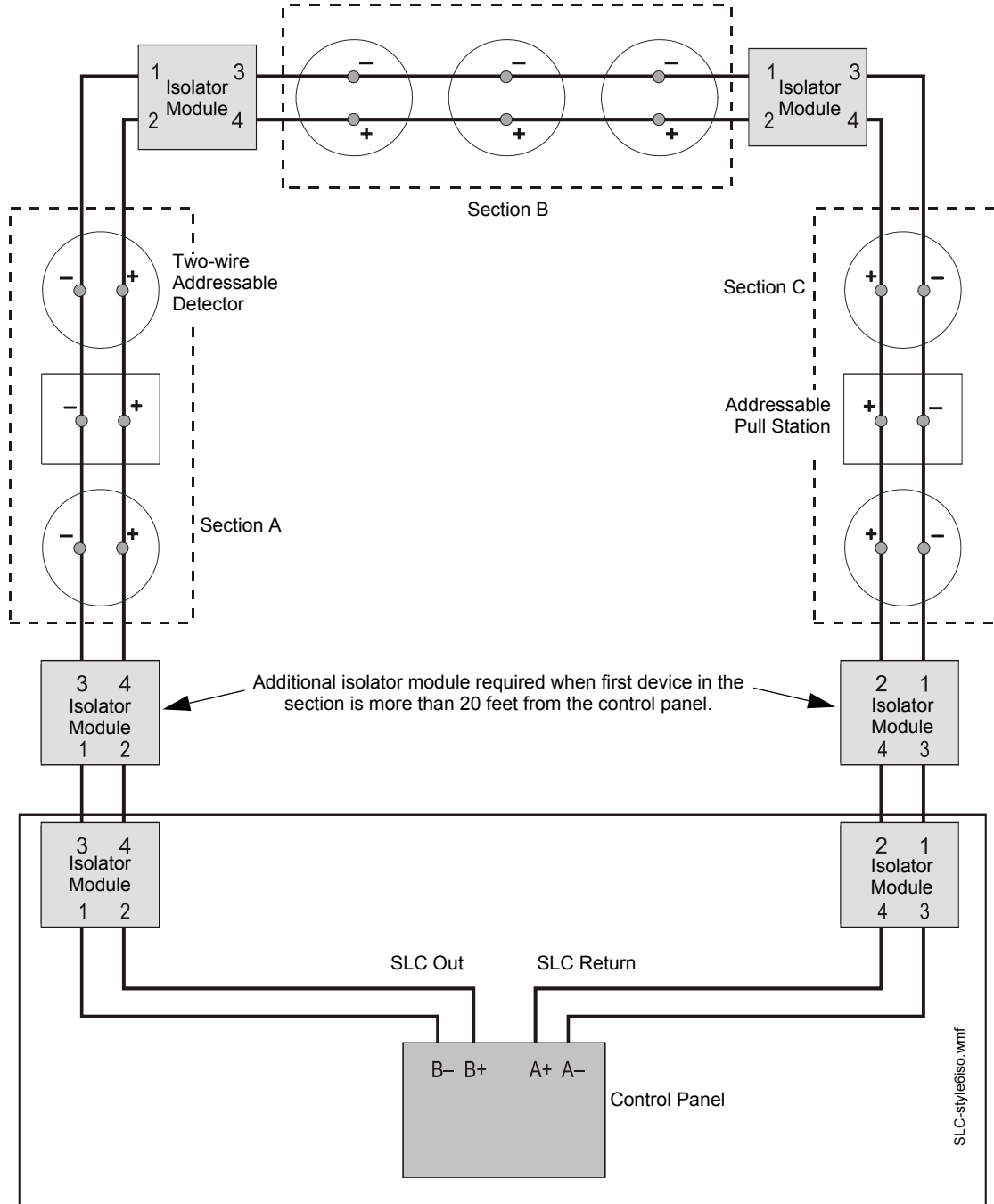

Figure 4.5 NFPA Style 6 SLC Using Isolator Modules

4.4 NFPA Style 7 SLC Using Isolator Modules

Style 7 operation requires using isolator modules (or a combination of isolator modules and isolator bases) before and after each device. Flanking each device with an isolator provides fault protection to all other devices on the loop.

- T-tapping is NOT allowed within the Style 7 wiring configuration.
- When a detector base or pull station is used, install isolator modules on both sides of the device.
- Connections between isolator modules and the device they isolate must be “close-nippled” conduit, within 3 feet (91.44 cm).

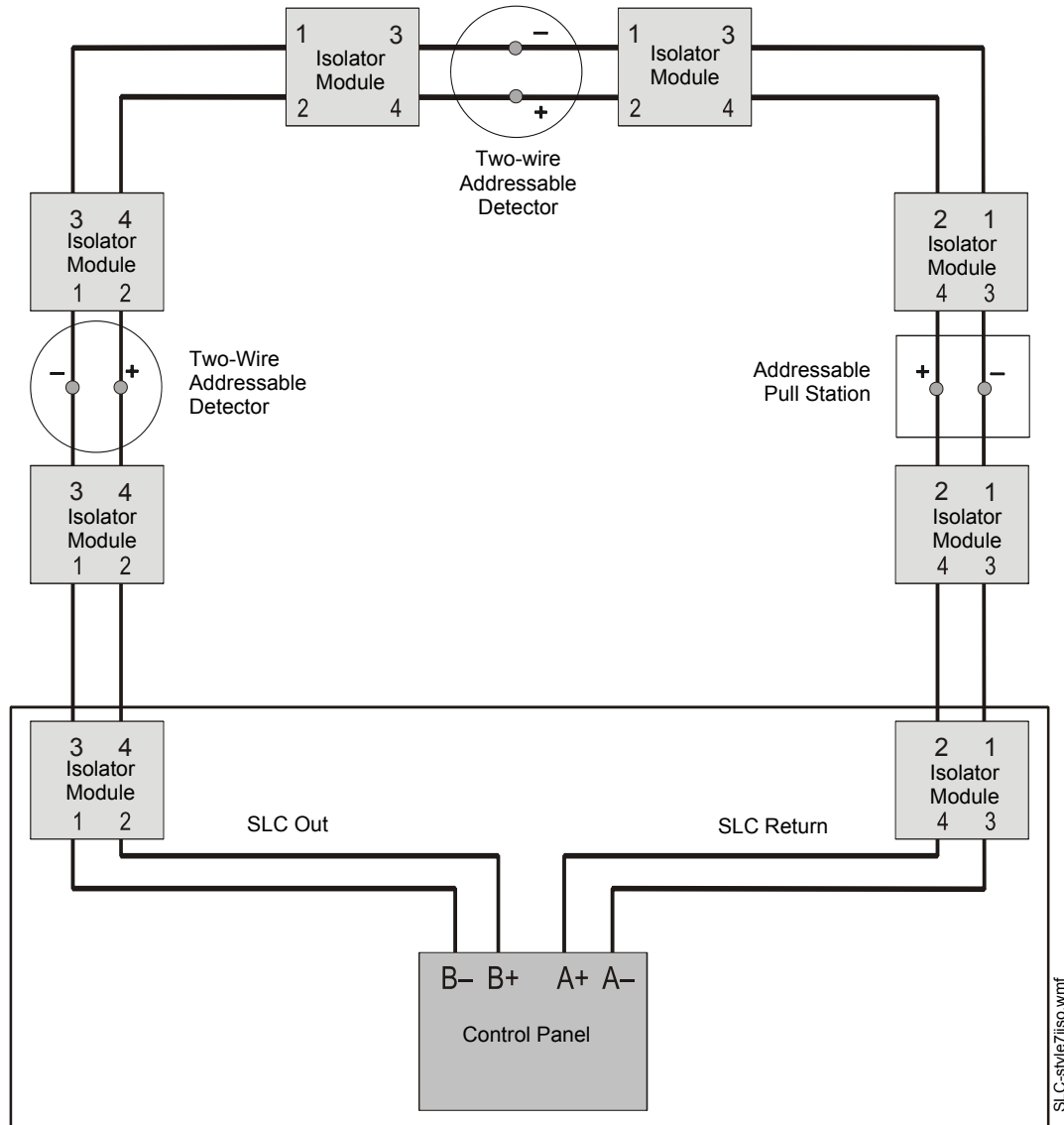

Figure 4.6 NFPA Style 7 SLC Using Isolator Modules

Section 5: Monitor Modules

5.1 Descriptions

These addressable modules monitor conventional contact-type alarm initiating devices. You can configure module circuits as an NFPA Style B (Class B) or Style D (Class A) Initiating Device Circuits (IDC). There is no limit to the number of contact-type devices installed on a monitor module circuit.



NOTE: For more information on the individual module specifications refer to the Installation Instructions that are provided with these devices.

5.1.1 Addressable Monitor Modules

MMF-300 Monitor Module

This is an addressable module that monitors either a Style B (Class B) or Style D (Class A) circuit of dry-contact input devices. This module is capable of participating in degraded mode where supported by the FACP.

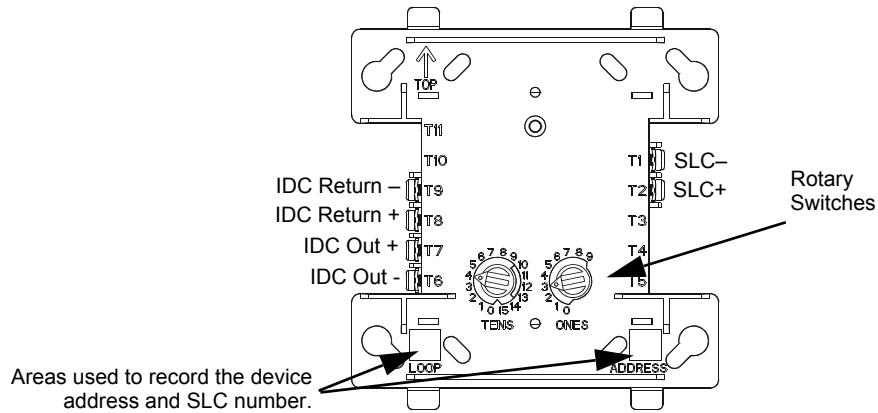

Figure 5.1 MMF-300 Monitor Module

FMMtp1.wmf

MMF-300-10 Monitor Module

This is an addressable monitor module intended to interface between the FACP and up to ten (10) Style B (Class B) or five (5) Style D (Class A) IDCs containing normally open contact devices.

This type of module is contained in either a BB-2 or BB-6 cabinet. The BB-2 can accommodate up to 2 modules and the BB-6, which requires the CH-6 chassis, can accommodate up to 6 modules.

See the *Installation Instructions* provided with module for proper installation into a cabinet.

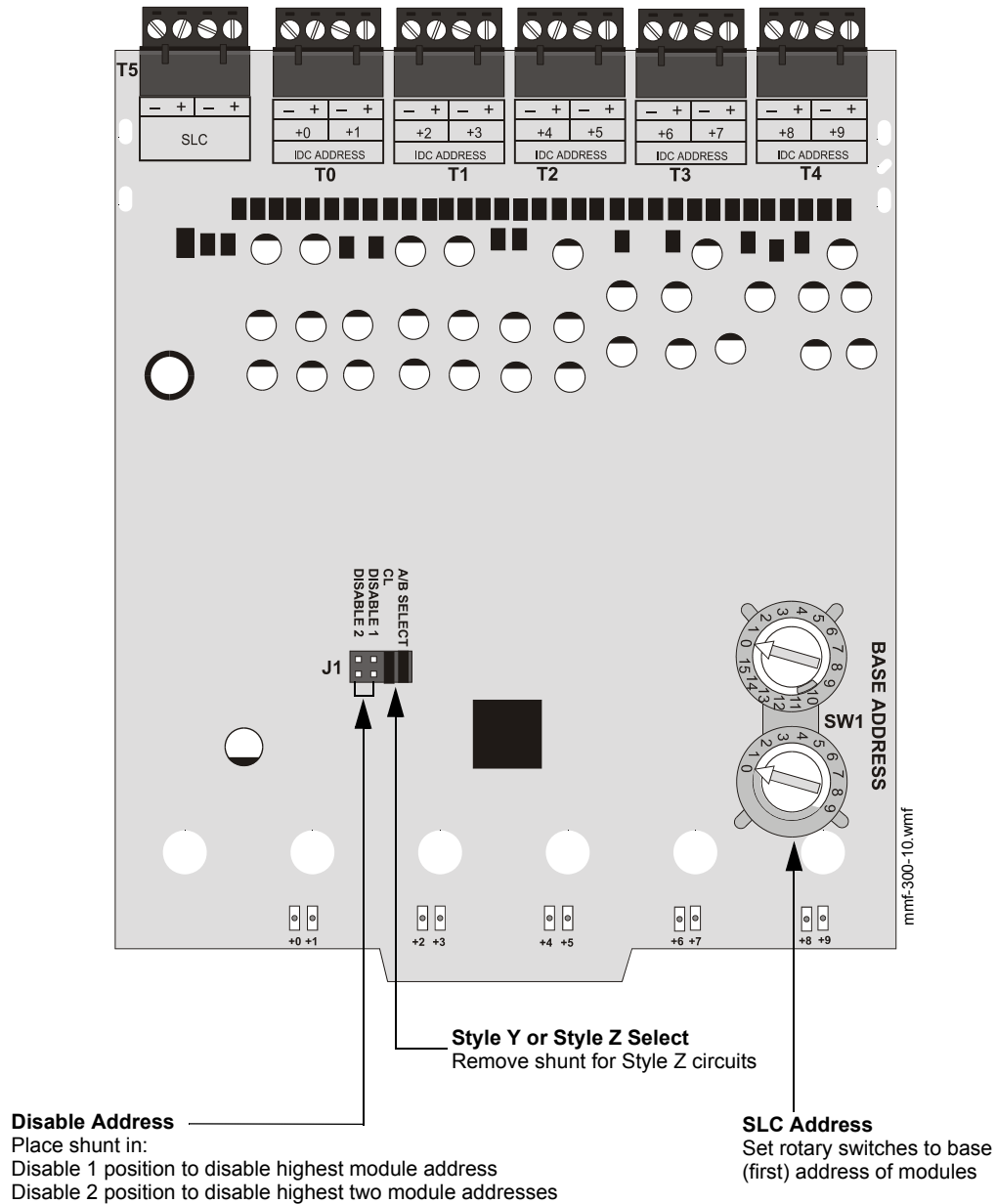
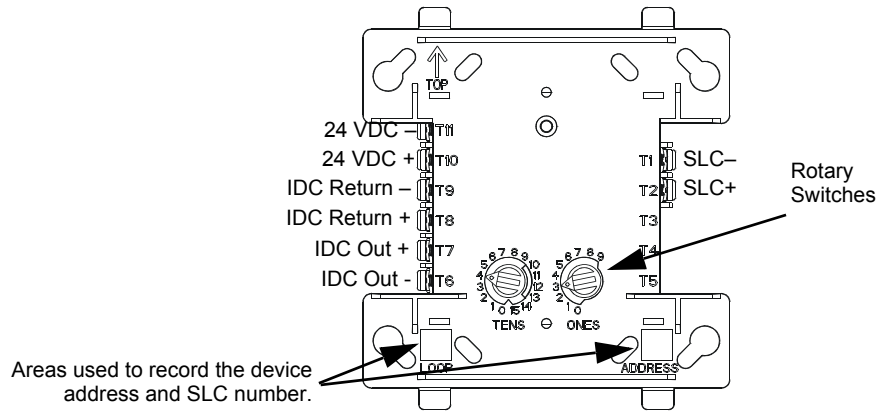

Figure 5.2 MMF-300-10 Monitor Module

5.1.2 Zone Interface Modules

MMF-302 Module

Similar to the MMF-300, this module is used to monitor a single IDC of UL listed compatible two-wire 24 volt conventional smoke detectors. Refer to the *Device Compatibility Document*.



FZNtph.wmf

Figure 5.3 MMF-302 Interface Module

MMF-302-6 Interface Module

This monitor module is intended to interface between the FACP and a conventional alarm system with up to six (6) Style B (Class B) or three (3) Style D (Class A) IDCs containing normally open contact devices.

This monitor module is contained in either a BB-2 or BB-6 cabinet. The BB-2 can accommodate up to 2 modules and the BB-6, which requires the CH-6 chassis, can accommodate up to 6 modules.

See the *Installation Instructions* provided with module for proper installation into cabinet.

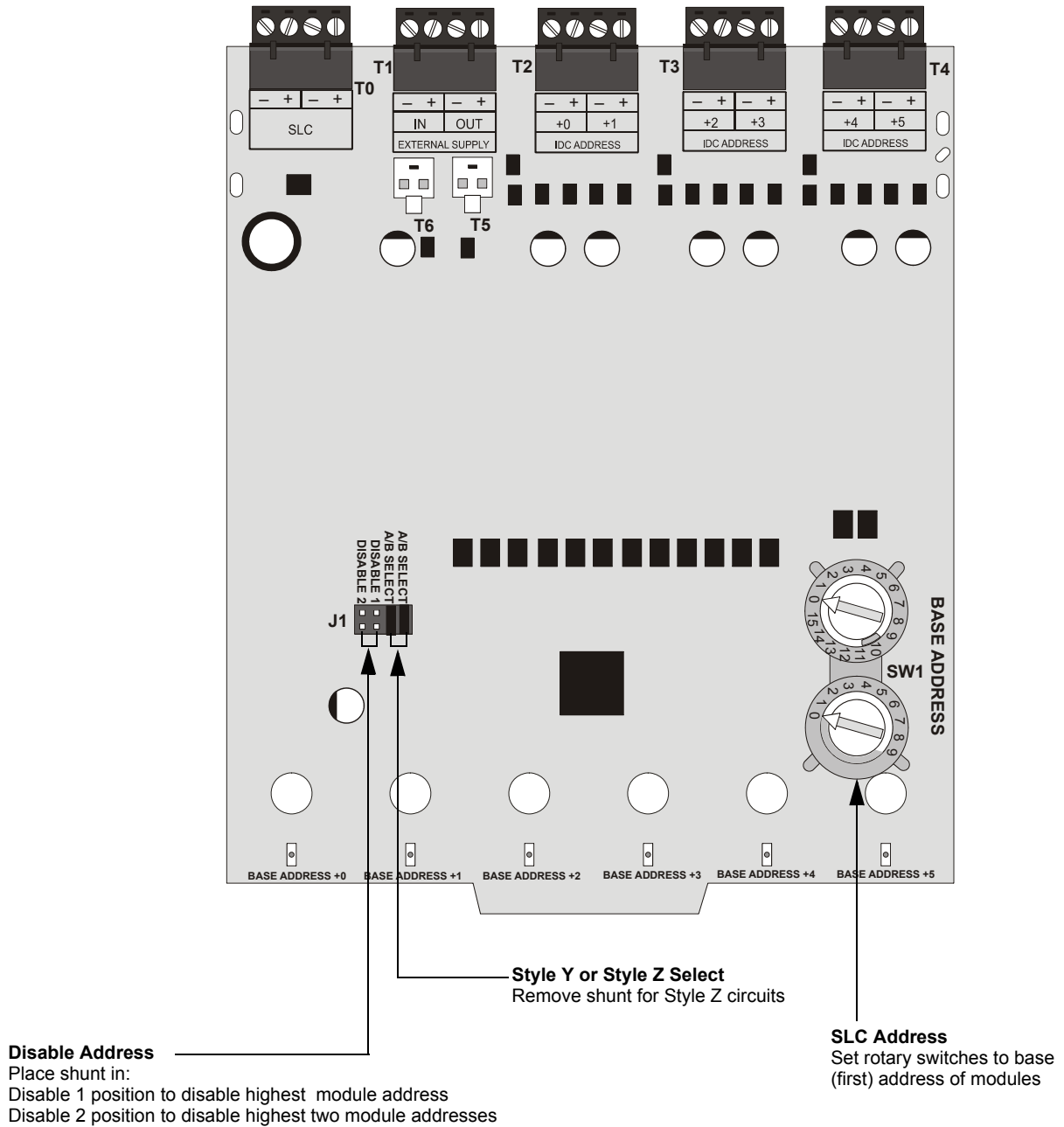

Figure 5.4 MMF-302-6 Interface Module

5.1.3 Dual Monitor Module

MDF-300 Module

The MDF-300 is similar to the MMF-300 but provides for two independent 2-wire IDCs at two separate, consecutive addresses.

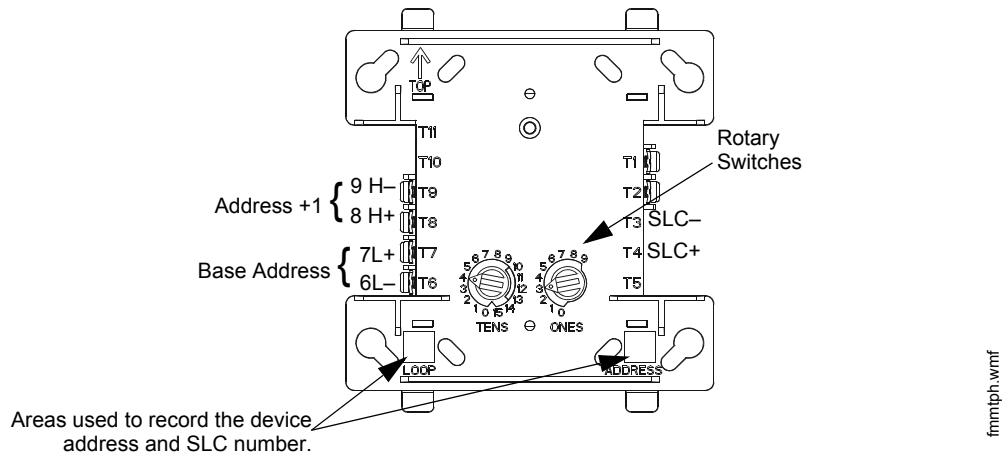

Figure 5.5 MDF-300 Dual Monitor Module

5.1.4 Mini Monitor Module

MMF-301 Monitor Module

The MMF-301 is functionally and electrically identical to an MMF-300, but is offered in a smaller package for mounting directly in the electrical box of the Style B (Class B) device being monitored.

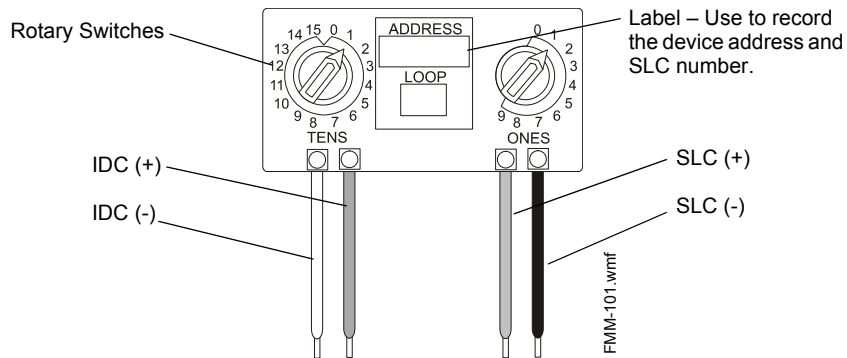

Figure 5.6 MMF-301 Mini Monitor Module

5.2 Installation

When installing any of these modules DO NOT mix the following services that the IDC provides:

- Fire alarm service
- Automatic and manual waterflow alarm service with normally open contact devices
- Sprinkler supervision with normally open contact devices

5.2.1 Setting an SLC address for a Single Point Module

Each module can be set to one of 159 addresses (01-159) and is factory preset with an address of “00”.



NOTE: The MS-9050UD and ES-50X can support addresses 01 - 50. The MS-9200, MS-9200UD, MS-9200UDLS, and ES-200X, can support module addresses of 01 - 99. The MS-9600, MS-9600LS, and MS-9600UDLS can support module addresses 01 - 159. The plastic stop located on the Tens switch must be removed to set addresses above 99.

To set an SLC address, use a screwdriver to adjust the rotary switches on the module to the desired address. The module below is set at “35”. When finished, mark the address on the module face in the place provided.

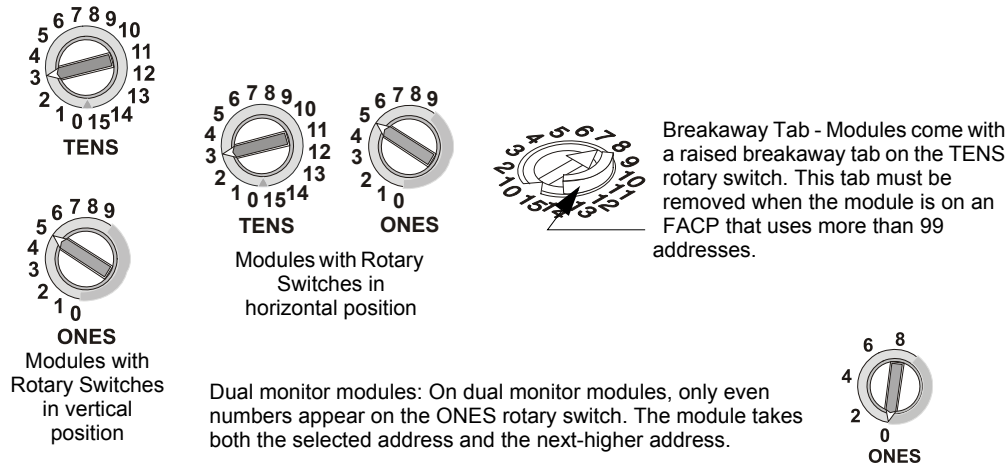

Figure 5.7 Setting an SLC Address on a Single Point Module

5.2.2 Setting an SLC address for a Multi-Point Module

The SLC address of a multi-point module is set in the same fashion as a single-point module.

In Class B operation, each MMF-300-10, MMF-302-6, CMF-300-6, and CRF-300-6 module is set to a base address. The remaining module points are automatically assigned to the next higher SLC addresses. For example, if the base address of an MMF-300-10 is set to 28, the next module points will be addressed to 29, 30, 31, 32, 33, 34, 35, 36 and 37.

In Class A operation, alternate module points are paired together, resulting in a total of five module points. For example, if the base address of an MMF-300-10 is set to 28, then 30, 32, 34 and 36 will be automatically assigned to the remaining module points and 29, 31, 33, 35 and 37 are available for use by other modules.



NOTE: The MS-9050UD and ES-50X can support addresses 01 - 50. The MS-9200, MS-9200UD, MS-9200UDLS, and ES-200X, can support module addresses of 01 - 99. The MS-9600, MS-9600LS, and MS-9600UDLS can support module addresses 01 - 159. The plastic stop located on the Tens switch must be removed to set addresses above 99.

To set an SLC address, use a common screwdriver to adjust the rotary switches on the module to the desired address. The module below is set at “28”.

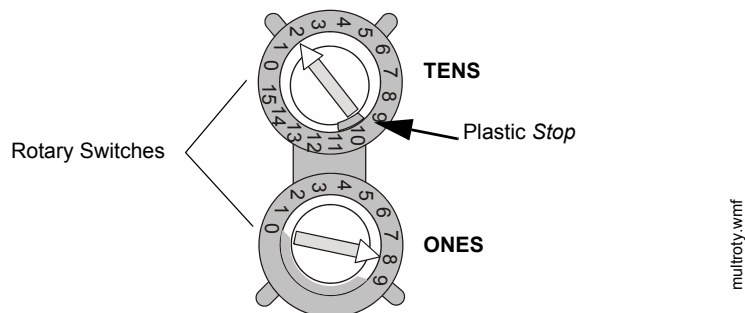

Figure 5.8 Setting an SLC Address on a Multi-Point Module

5.3 MMF-300 Wiring Diagrams

Following are wiring diagrams that depict NFPA Style B (Class B) and D (Class A) Initiating Device Circuits (IDCs) using MMF-300 monitor modules.

The Initiating Device Circuit (IDC) is supervised and current-limited to 210 microamperes @ 24 VDC (nominal).

5.3.1 Wiring a NFPA Style B IDC with an MMF-300

Connect the SLC wiring to the module terminals 1 (-) and 2 (+).

Each module takes one address on the SLC. Use the rotary switches on the module to set it to the required SLC address. Refer to “Setting an SLC address for a Single Point Module” on page 33.

The figure below shows typical wiring for a supervised and power-limited NFPA Style B IDC using an MMF-300 module.

- Refer to the *Device Compatibility Document* for compatible smoke detectors.
- See “Power Considerations” on page 63 for information on supervising 24 VDC power.

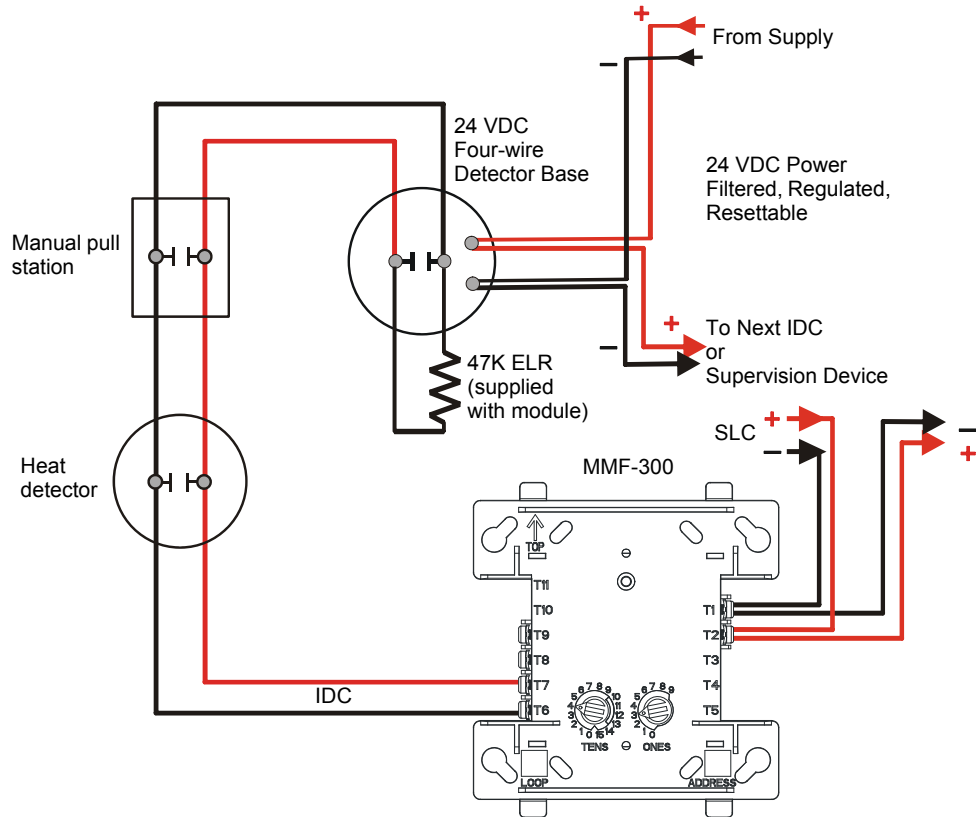

Figure 5.9 Typical Style B IDC Wiring with an MMF-300

SLC-iddB1tpH.wmf

5.3.2 Wiring a NFPA Style D IDC with an MMF-300

Connect the SLC wiring to the module terminals 1 (-) and 2 (+).

Each module takes one address on the SLC. Use the rotary switches on the module to set it to the required SLC address. Refer to “Setting an SLC address for a Single Point Module” on page 33.

The figure below shows typical wiring for a supervised and power-limited NFPA Style D (Class A) IDC using an MMF-300 module.

- Refer to the *Device Compatibility Document* for compatible smoke detectors.
- See “Power Considerations” on page 63 for information on supervising 24 VDC power.

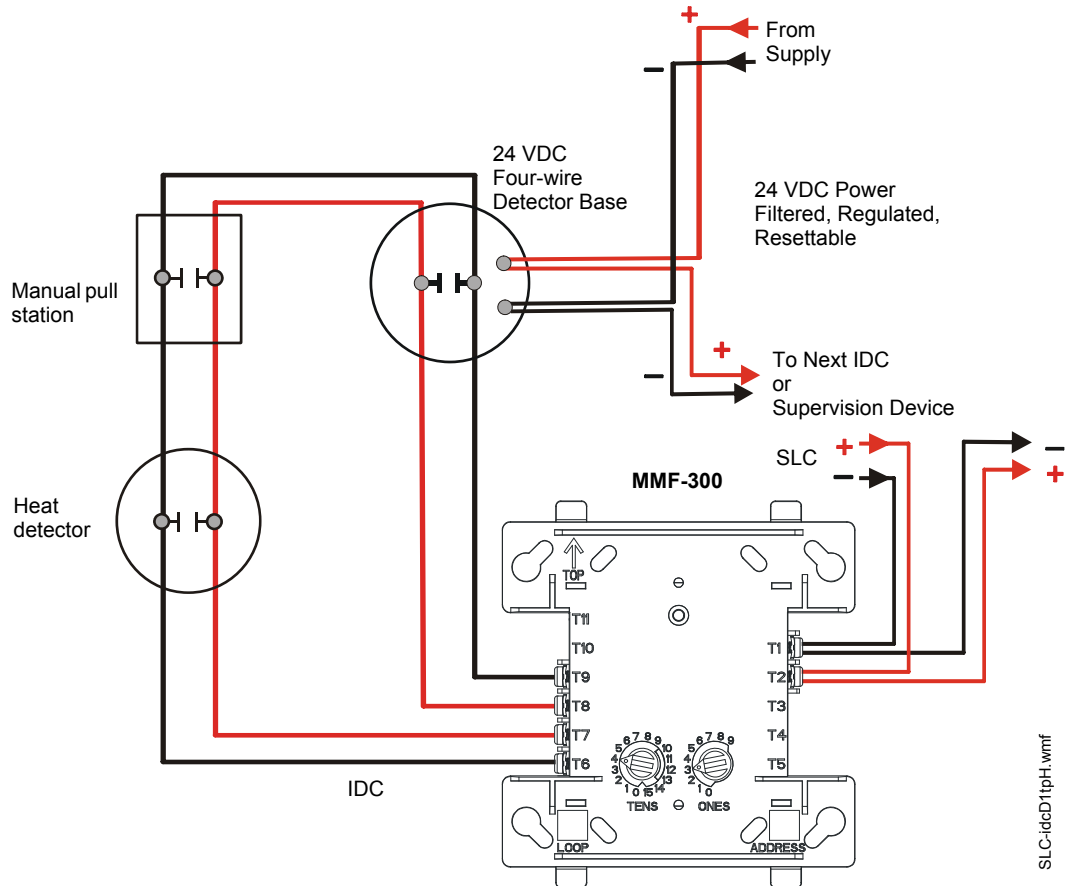

Figure 5.10 Typical Style D IDC Wiring with an MMF-300

5.3.3 MMF-300 Wiring for Emergency Alarm System Applications

Connect the SLC wiring to the module terminals 1 (-) and 2 (+).

Each module takes one address on the SLC. Use the rotary switches on the module to set it to the required SLC address. Refer to “Setting an SLC address for a Single Point Module” on page 33.

The figure below shows typical wiring for a supervised and power-limited Emergency Signaling circuit using an MMF-300 module.

- See “Power Considerations” on page 63 for information on supervising 24 VDC power.
- See Section 6, “Control Modules” for instructions on using control modules as NACs on an SLC.
- Refer to the *Device Compatibility Document* #15384 for compatible smoke detectors.

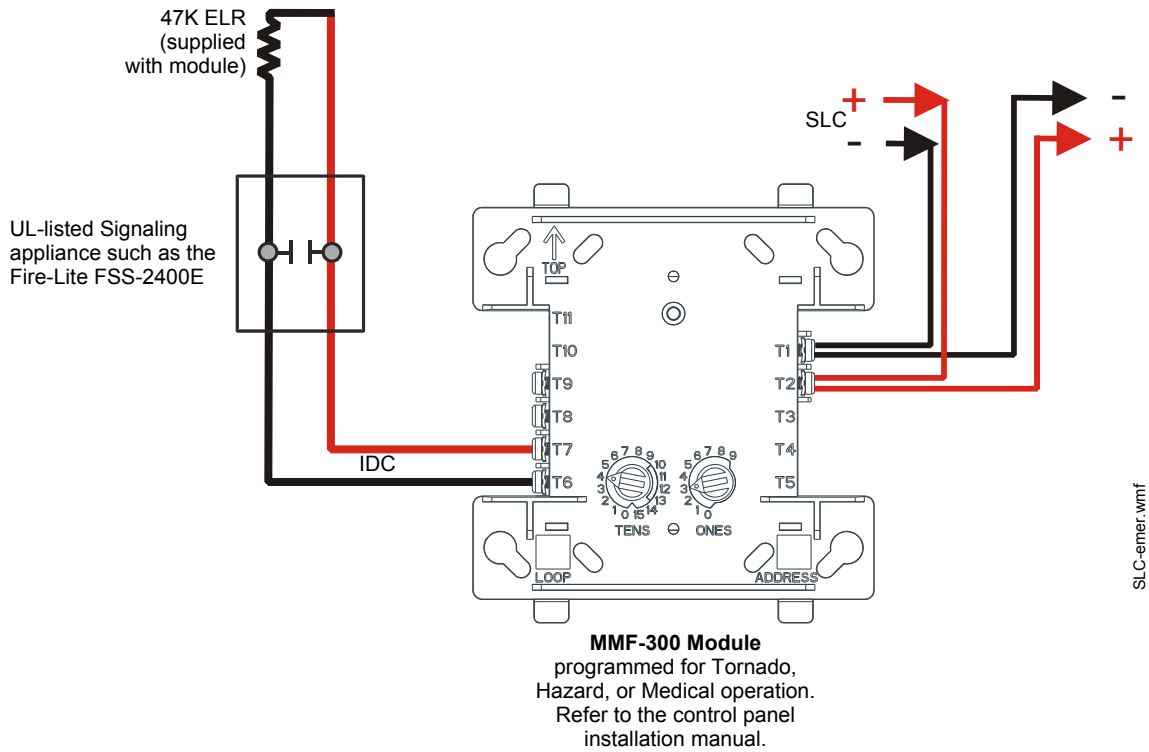

Figure 5.11 Emergency Signaling Wiring with an MMF-300

5.4 MMF-300-10 Wiring Diagrams

Following are wiring diagrams that depict NFPA Style B (Class B) and D (Class A) Initiating Device Circuits (IDCs) using MMF-300-10 monitor modules.

The Initiating Device Circuit (IDC) is supervised and current-limited to 1.0 milliampere @ 24 VDC (nominal).

5.4.1 Wiring a NFPA Style B IDC with an MMF-300-10

Connect the SLC wiring to the module terminals T5 as shown below.

Use the rotary switches on the module to set the base SLC address. Each module takes ten addresses on the SLC. The remaining module points are automatically assigned to the next nine higher addresses. Refer to “Setting an SLC address for a Multi-Point Module” on page 33.

DO NOT set the lowest address above 150 (41 for the MS-9050UD or ES-50X, 90 for the MS-9200, MS-9200UD, MS-9200UDLS, or ES-200X), as the other module points will be assigned to nonexistent addresses.

The figure below shows typical wiring for a supervised and power-limited NFPA Style B IDC using an MMF-300-10 module.

- Refer to the *Device Compatibility Document* for compatible smoke detectors.
- See “Power Considerations” on page 63 for information on supervising 24 VDC power.

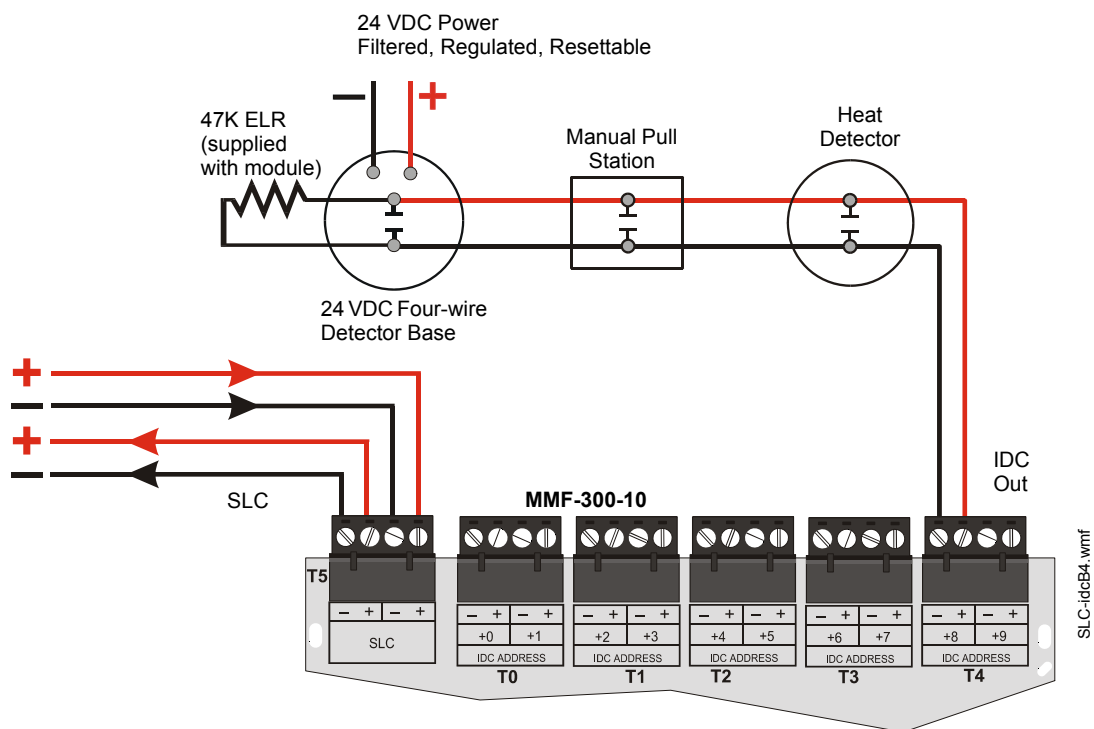

Figure 5.12 Typical Style B IDC Wiring with an MMF-300-10

5.4.2 Wiring a NFPA Style D IDC with an MMF-300-10

Connect the SLC wiring to the module terminals T5 as shown below.

Use the rotary switches on the module to set the base SLC address. Each module takes five alternating addresses on the SLC. The remaining module points are automatically assigned to the next four higher addresses. (Example: 28, 30, 32, 34 and 36). Refer to “Setting an SLC address for a Multi-Point Module” on page 33.

DO NOT set the lowest address above 150 (41 for the MS-9050UD or ES-50X, 90 for the MS-9200, MS-9200UD, MS-9200UDLS, or ES-200X), as the other module points will be assigned to nonexistent addresses.

The figure below shows typical wiring for a supervised and power-limited NFPA Style D (Class A) IDC using an MMF-300-10 module.

- Refer to the *Device Compatibility Document* for compatible smoke detectors.
- See “Power Considerations” on page 63 for information on supervising 24 VDC power.

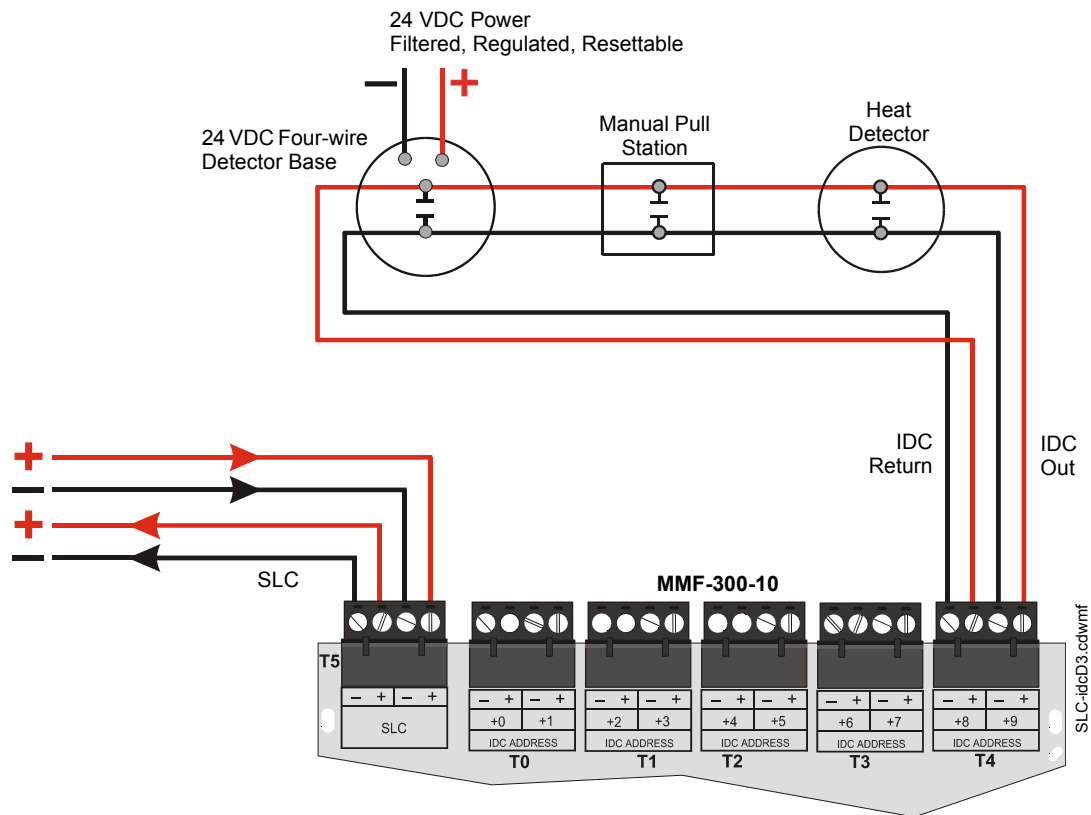

Figure 5.13 Typical Style D IDC Wiring with an MMF-300-10

5.5 MDF-300 Wiring Diagrams

Following is a wiring diagrams that depict NFPA Style B (Class B) Initiating Device Circuits (IDCs) using MDF-300 Dual Monitor Modules.

5.5.1 Wiring a NFPA Style B IDC with an MDF-300

Connect the SLC wiring to the module terminals 1 (-) and 2 (+).

Use the rotary switches on the module to set it to the SLC address. Each dual module takes two addresses on the SLC. Circuit 'L' corresponds to the address set on the rotary switches, which will be an even number. Circuit 'H' will automatically respond to the next higher address, which will be an odd number. Use caution to avoid duplicate addressing of modules on the system. Refer to "Setting an SLC address for a Single Point Module" on page 33.

Each IDC (H & L) is power limited to 230 microamperes @ 24 VDC.

The figure below shows typical wiring for a supervised and power-limited NFPA Style B IDC using an MDF-300-10 module.

- Refer to the *Device Compatibility Document* for compatible smoke detectors.
- See "Power Considerations" on page 63 for information on supervising 24 VDC power.

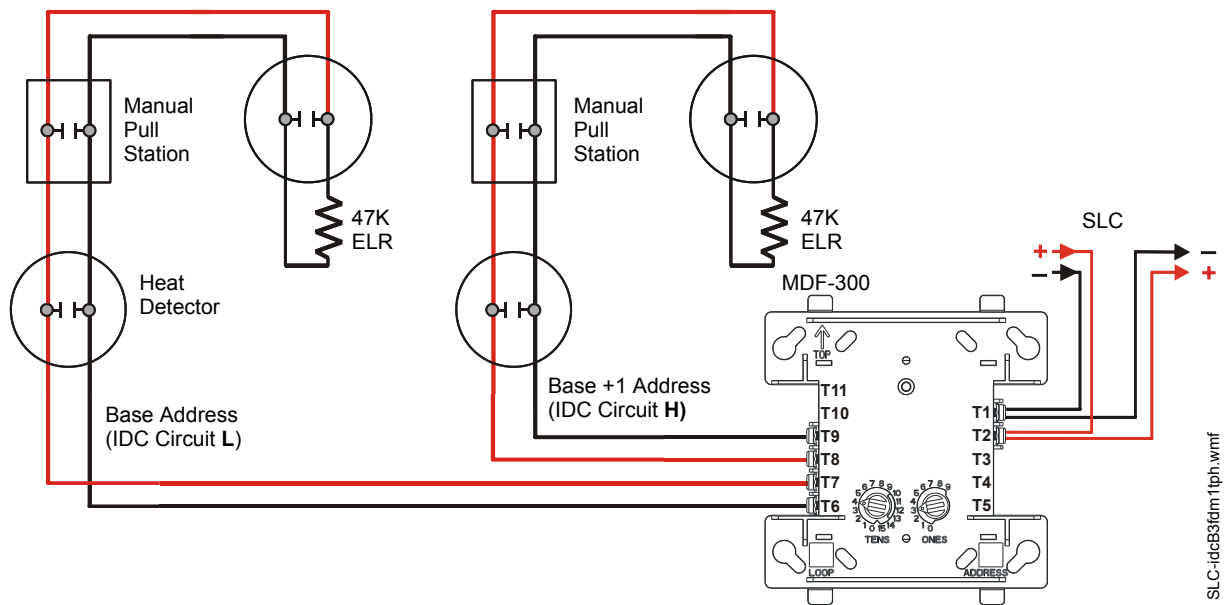

Figure 5.14 Typical Style B IDC Wiring with an MDF-300

5.6 MMF-302 Wiring Diagrams

Following are wiring diagrams that concern NFPA Style B (Class B) and D (Class A) Initiating Device Circuits (IDCs) using MMF-302 Zone Interface Modules.

5.6.1 Wiring a NFPA Style B IDC with an MMF-302

Connect the SLC wiring to the module terminals 1 (-) and 2 (+).

Each module takes one address on the SLC. Use the rotary switches on the module to set it to the required SLC address. Refer to “Setting an SLC address for a Single Point Module” on page 33.

The IDC is supervised and power limited to 230 microamperes @ 24 VDC.

The figure below shows typical wiring for a supervised and power-limited NFPA Style B IDC using an MMF-302 module.

- Refer to the *Device Compatibility Document* for compatible smoke detectors.
- 24 VDC power must be provided from a UL listed power supply for fire protection use. This power is inherently supervised by the module.
- See “Power Considerations” on page 63 for information on 24 VDC power.

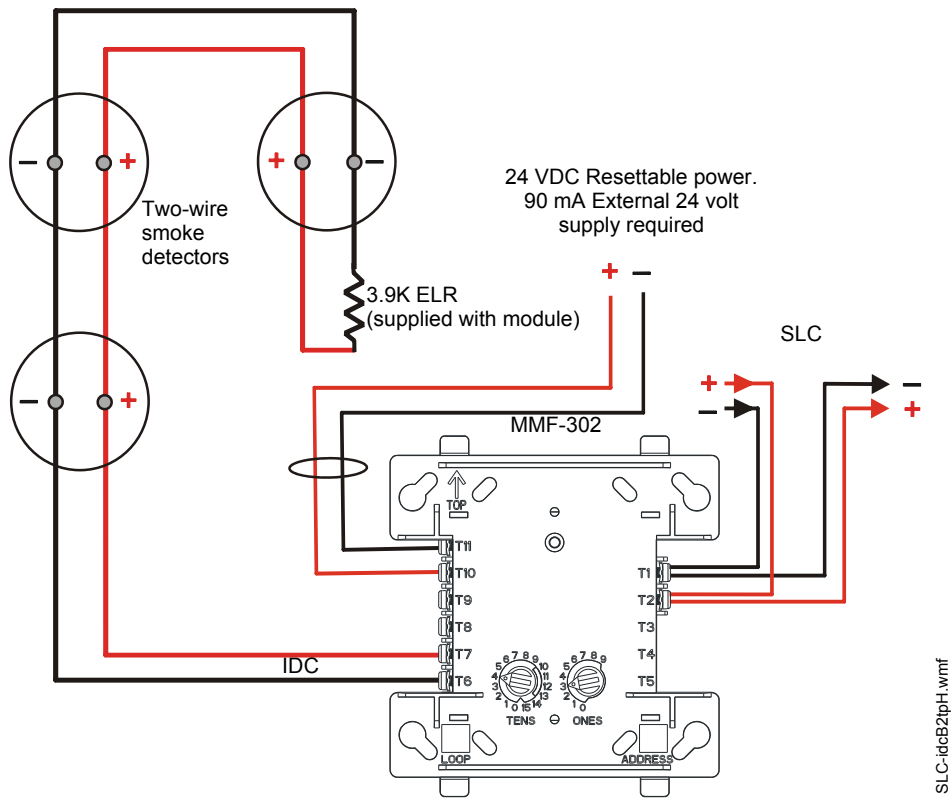

Figure 5.15 Typical Style B IDC Wiring with an MMF-302

5.6.2 Wiring a NFPA Style D IDC with an MMF-302

Connect the SLC wiring to the module terminals 1 (-) and 2 (+).

Each module takes one address on the SLC. Use the rotary switches on the module to set it to the required SLC address. Refer to “Setting an SLC address for a Single Point Module” on page 33.

The figure below shows typical wiring for a supervised and power-limited NFPA Style D (Class A) IDC using an MMF-302 module.

- Refer to the *Device Compatibility Document* for compatible smoke detectors.
- 24 VDC power must be provided from a UL listed power supply for fire protection use. This power is inherently supervised by the module.
- See “Power Considerations” on page 63 for information on 24 VDC power.

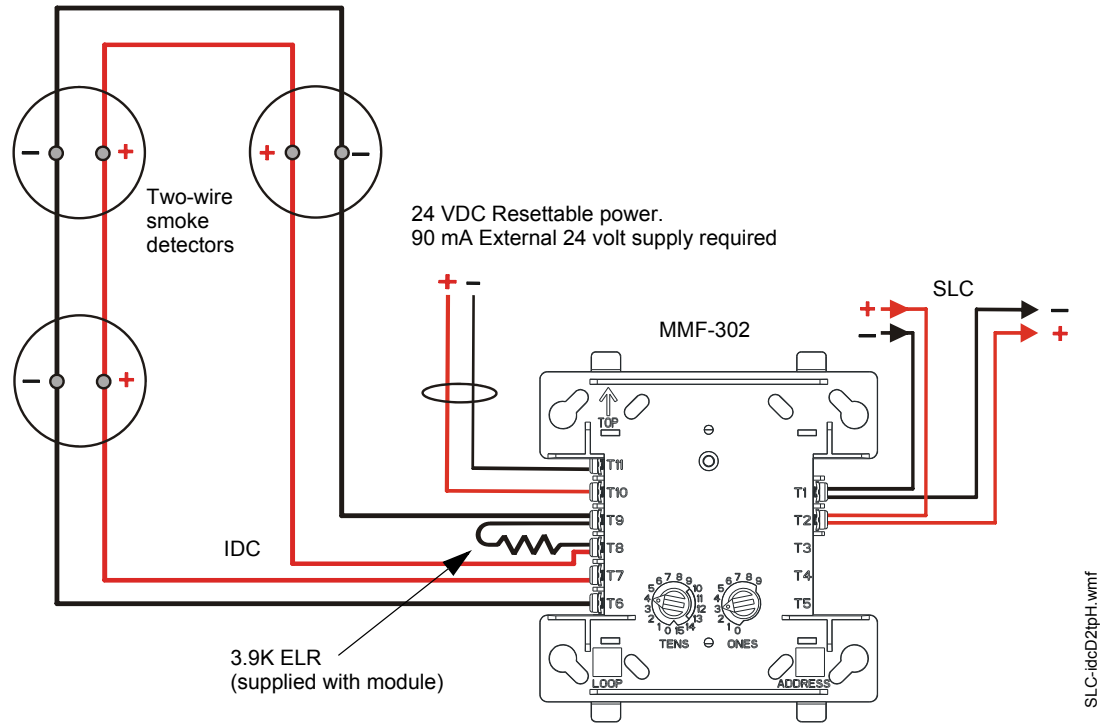

Figure 5.16 Typical Style D IDC Wiring with an MMF-302

5.7 MMF-302-6 Wiring Diagrams

Following are wiring diagrams that concern NFPA Style B (Class B) and D (Class A) Initiating Device Circuits (IDCs) using MMF-302-6 monitor modules.

5.7.1 Wiring a NFPA Style B IDC with an MMF-302-6

Connect the SLC wiring to the module terminals T0 as shown below.

Use the rotary switches on the module to set the base SLC address. Each module takes six addresses on the SLC. The remaining module points are automatically assigned to the next five higher addresses. Refer to “Setting an SLC address for a Multi-Point Module” on page 33.

DO NOT set the lowest address above 150 (41 for the MS-9050UD or ES-50X, 90 for the MS-9200, MS-9200UD, MS-9200UDLS, or ES-200X), as the other module points will be assigned to nonexistent addresses.

The figure below shows typical wiring for a supervised and power-limited NFPA Style B IDC using an MMF-302-6 module.

- Refer to the *Device Compatibility Document* for compatible smoke detectors.
- 24 VDC power must be provided from a UL listed power supply for fire protection use. This power is inherently supervised by the module.
- See “Power Considerations” on page 63 for information on 24 VDC power.

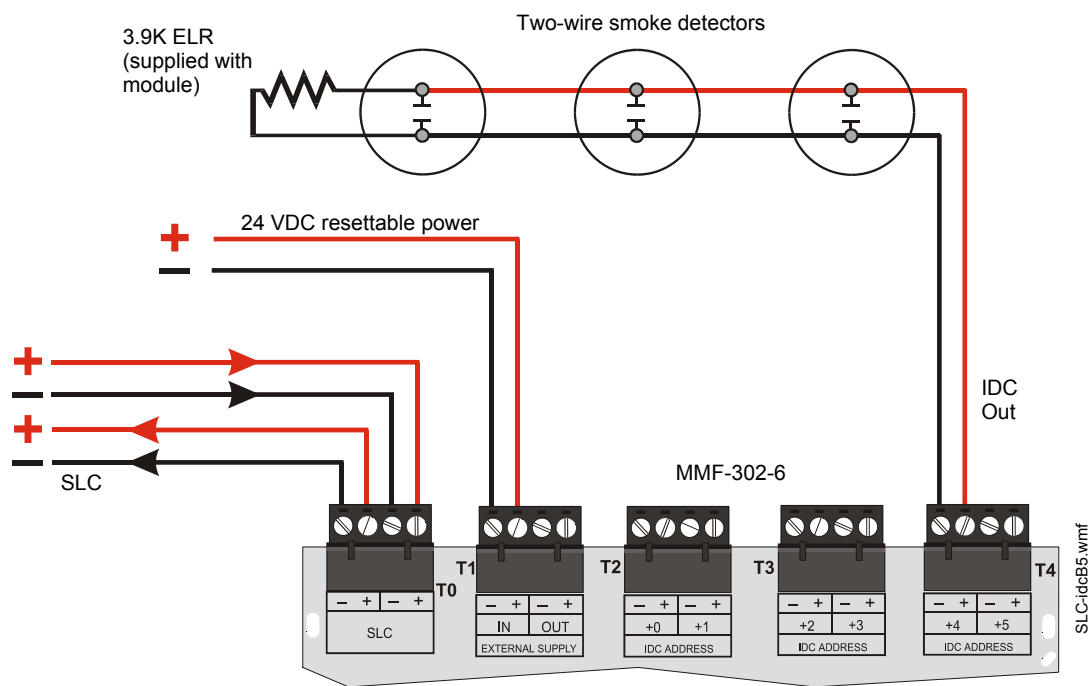

Figure 5.17 Typical Style B IDC Wiring with an MMF-302-6

5.7.2 Wiring a NFPA Style D IDC with an MMF-302-6

Connect the SLC wiring to the module terminals T0 as shown below.

Use the rotary switches on the module to set it to the SLC addresses. Each module takes three alternating addresses on the SLC. The remaining module points are automatically assigned to the next two higher addresses. (Example: 28, 30 and 32). Refer to “Setting an SLC address for a Multi-Point Module” on page 33.

DO NOT set the lowest address above 150 (41 for the MS-9050UD or ES-50X, 90 for the MS-9200, MS-9200UD, MS-9200UDLS, or ES-200X), as the other module points will be assigned to nonexistent addresses.

The figure below shows typical wiring for a supervised and power-limited NFPA Style D (Class A) IDC using an MMF-302-6 module.

- Refer to the *Device Compatibility Document* for compatible smoke detectors.
- 24 VDC power must be provided from a UL listed power supply for fire protection use. This power is inherently supervised by the module.
- See “Power Considerations” on page 63 for information on 24 VDC power.

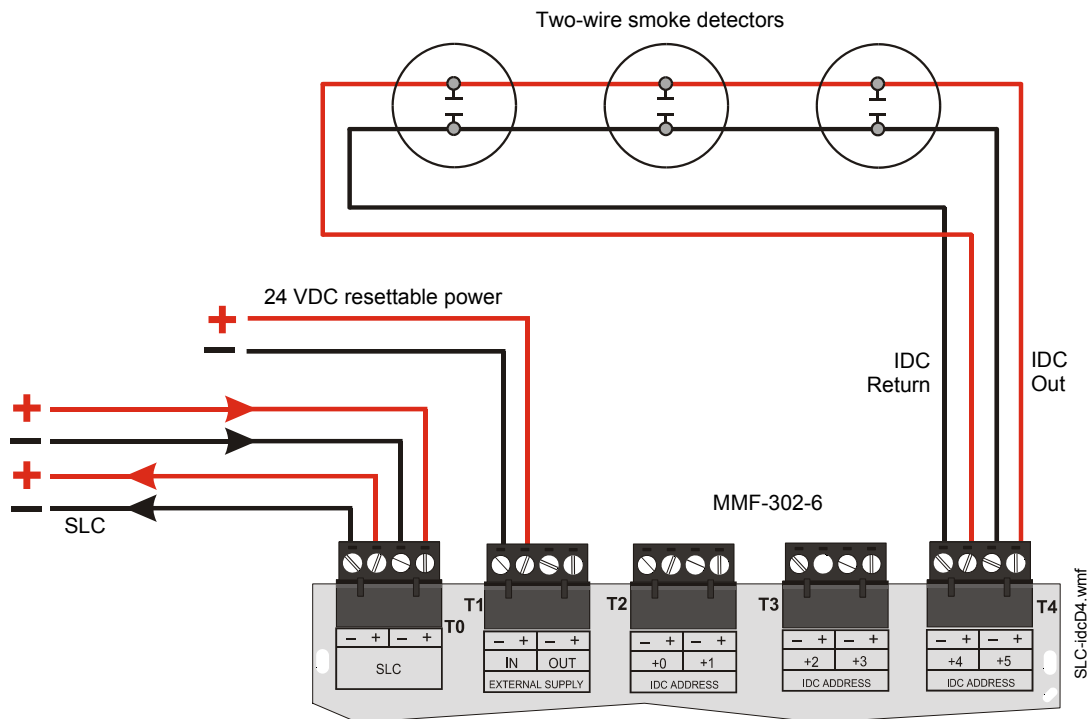

Figure 5.18 Typical Style D IDC Wiring with an MMF-302-6

Section 6: Control Modules

When using a Control Module as a Notification Appliance Circuit (NAC), the isolation described in the section titled Section 4, “SLC Circuits with Isolators” which begins on page 22, is required or Riser Conductors must be installed in accordance with the survivability from attack by fire requirements in National Fire Alarm Code, NFPA 72.

6.1 Description

The CMF-300 and CMF-300-6 modules are addressable modules that can be used for monitoring and switching 24 VDC Notification Appliance Circuit (NAC) power for NFPA Style Y (Class B) and NFPA Style Z (Class A) circuits.

Ratings for the relay contacts on the module are:

Load Description	Application	Maximum Voltage	Current Rating
Resistive	Non-Coded	30 VDC	3.0 A
Resistive	Coded	30 VDC	2.0 A
Resistive	Non-Coded	110 VDC	0.9 A
Resistive	Non-Coded	125 VAC (CMF-300) 70.7 VAC (CMF-300-6)	0.9 A
Inductive (L/R = 5ms)	Coded	30 VDC	0.5 A
Inductive (L/R = 2ms)	Coded	30 VDC	1.0 A
Inductive (PF = 0.35)	Non-Coded	125 VAC (CMF-300) 70.7 VAC (CMF-300-6)	0.5 A



NOTE: For more information on module specifications, refer to the Installation Instructions provided with these devices.

6.2 CMF-300 Installation

6.2.1 Setting an SLC address for a CMF-300 Module

Each module is factory preset with an address of “00”. To set an SLC address refer to “Setting an SLC address for a Single Point Module” on page 33.

6.2.2 Wiring a Notification Appliance Circuit (NAC) with a CMF-300

The figure below shows the connections to wire a module for powering a 24 VDC NAC:

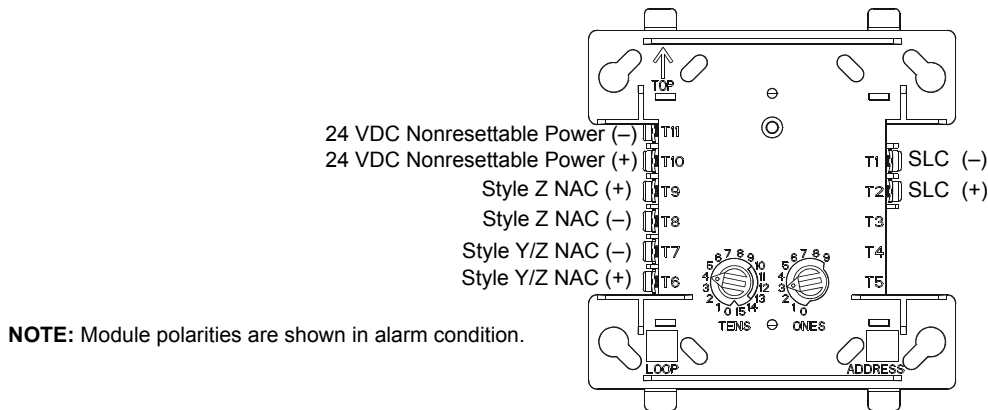

Figure 6.1 CMF-300 Wiring Connections

6.3 Wiring a CMF-300 Module

This section contains instructions and diagrams for wiring a Signaling Line Circuit with a CMF-300 as a Notification Appliance Circuit (NAC).

6.3.1 Wiring a Style Y NAC (Two-Wire) with Addressable Control Modules

A supervised and power-limited NFPA Style Y (Class B) NAC using a CMF-300 module. Polarized alarm notification appliances are shown connected to the module in a two-wire configuration. Refer to the *Device Compatibility Document* for compatible notification appliances and relays.

- See “Power Considerations” on page 63 for information on monitoring 24 VDC power.
- Each module can control 2 amps of resistive load (on electronic devices) or 1 amp of inductive load (on mechanical bells and horns).
- 24 VDC power must be provided from a UL listed power supply for fire protection use.

- A power supervision relay is required only on the last module of the power run.
- Do not T-tap or branch a Style Y circuit.
- Terminate the circuit across the last device using an End-of-Line Resistor 47K, 1/2-watt, P/N SSD A2143-00 (ELR-47K in Canada).
- Do not loop wiring under the screw terminals of any notification appliance. To maintain supervision, break the wire run at each device.

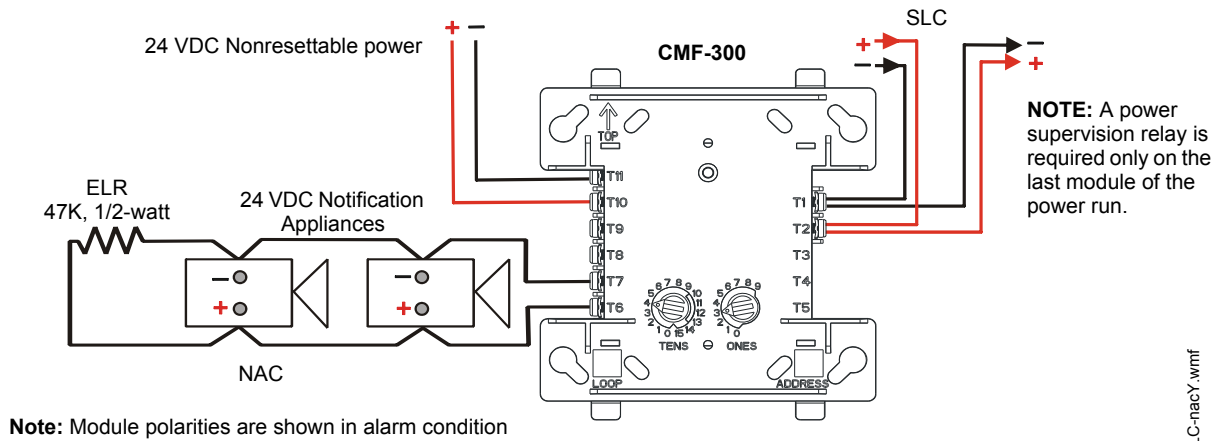

Figure 6.2 NFPA Style Y Notification Appliance Circuit

6.3.2 Wiring a Style Z NAC (Four-Wire) with Addressable Control Modules

A supervised and power-limited NFPA Style Z (Class A) NAC using a CMF-300 module. Polarized alarm notification appliances are shown connected to the module in a four-wire configuration.



NOTE: Refer to the *Device Compatibility Document* for compatible notification appliances and relays.

- See “Power Considerations” on page 63 for information on monitoring 24 VDC power.
- Each module can control 2 amps of resistive load (on electronic devices) or 1 amp of inductive load (on mechanical bells and horns).
- 24 VDC power must be provided from a UL listed power supply for fire protection use.
- A power supervision relay is required only on the last module of the power run.
- Do not T-tap or branch a Style Z circuit.
- Do not loop wiring under the screw terminals of any notification appliance. To maintain supervision, break the wire run at each device.

NOTE: A power supervision relay is required only on the last module of the power.

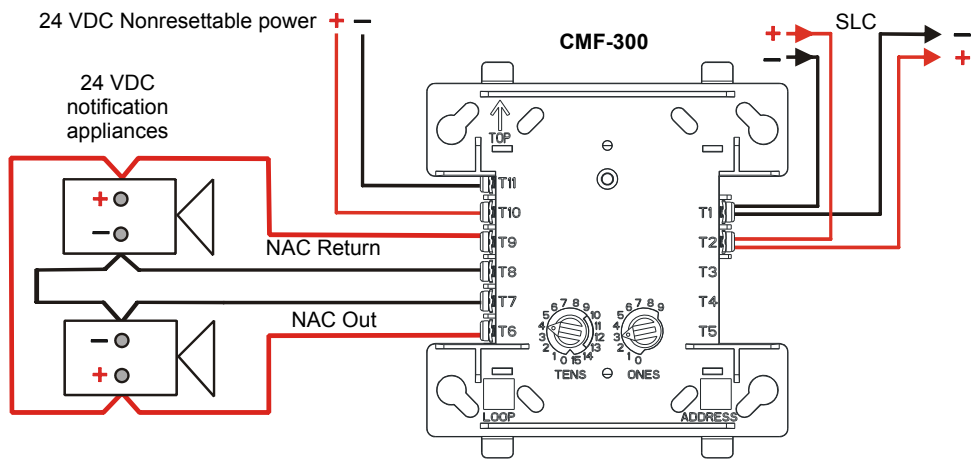

Figure 6.3 NFPA Style Z Notification Appliance Circuit

6.4 CMF-300-6 Installation

6.4.1 Cabinet Installation

This type of module is contained in either a BB-2 cabinet. The BB-2 can accommodate up to 2 modules and the BB-6, which requires the CH-6, can accommodate up to 6 modules.

See the *Installation Instructions* provided with module for proper installation into cabinet.

6.4.2 Setting an SLC address for an CMF-300-6 Module

In “Style Y” operation each CMF-300-6 module can be set to one of 154 base addresses (01-154). The remaining module points are automatically assigned to the next five higher SLC addresses. For example, if the base address is set to 28, the next five module points will be addressed to 29, 30, 31, 32 and 33.

In “Style Z” operation alternate module points are paired together, resulting in a total of three module points. For example, if the base address is set to 28, then 30 and 32 will be automatically assigned to the remaining module points and 29, 31 and 33 are available to be used for other modules on the SLC.

DO NOT set the lowest address above 154 (45 for the MS-9050UD or ES-50X, 94 for the MS-9200, MS-9200UD, MS-9200UDLS, or ES-200X), as the other module points will be assigned to nonexistent addresses.



NOTE: The MS-9050UD and ES-50X can support addresses 01 - 50. The MS-9200, MS-9200UD, MS-9200UDLS, and ES-200X can support module addresses of 01 - 99. The MS-9600, MS-9600LS, MS-9600LSC, and MS-9600UDLS can support module addresses 01 - 159.

To set an SLC address, use a common screwdriver to adjust the rotary switches on the module to the desired address. See Figure 6.4 on page 47.



NOTE: For use with the MS-9600, MS-9600LS, MS-9600LSC, and MS-9600UDLS, remove the stop on the upper rotary switch.

6.4.3 Setting NACs as Style Y or Style Z

To use this module for Style Y (Class B) operation ascertain that a small shunt is installed on the “A/B SELECT” set of pins. (As shipped).

To use this module for Style Z (Class A) operation remove the small shunt from the “A/B SELECT” set of pins. See drawing below and Figure 6.4 on page 47.

6.4.4 Disabling Unused Module Addresses

A shunt is used, in conjunction with a pin block, to disable a maximum of three (3) unused module addresses. If two module addresses are disabled, the lowest four addresses will be functional, while the highest two will be disabled. For example, if the shunt is placed on ‘DISABLE 2’ and the base address is set to 28, the module addresses will be assigned to 28, 29, 30 and 31.

In Style Z operation, placing a small shunt on ‘DISABLE 3’ will disable all three addresses. Placing it on ‘DISABLE 2’ will disable two out of three addresses.

To disable addresses, securely place one of the supplied small shunts onto the desired set of pins. See drawing and Figure 6.4 on page 47.

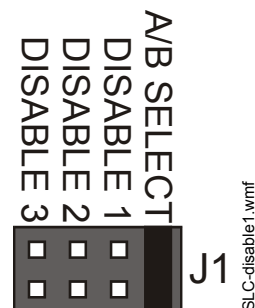

6.4.5 Short Circuit Protection

Protection is disabled for each module address when there is a large shunt installed on the corresponding pins of the pin block (as shipped, all six addresses are disabled).

When enabled, the module will not switch power supply if a short circuit condition exists on a NAC.

To enable “Short Circuit Protection” for an address, remove the large shunt from the corresponding pins of the pin block. See Figure 6.4 on page 47. Place unused shunts on single pin to store on board for future use.

6.4.6 Features Not Supported

The “Synchronization” and “Power Supply Monitoring” features are not supported at this time.

6.4.7 Circuit Board Information

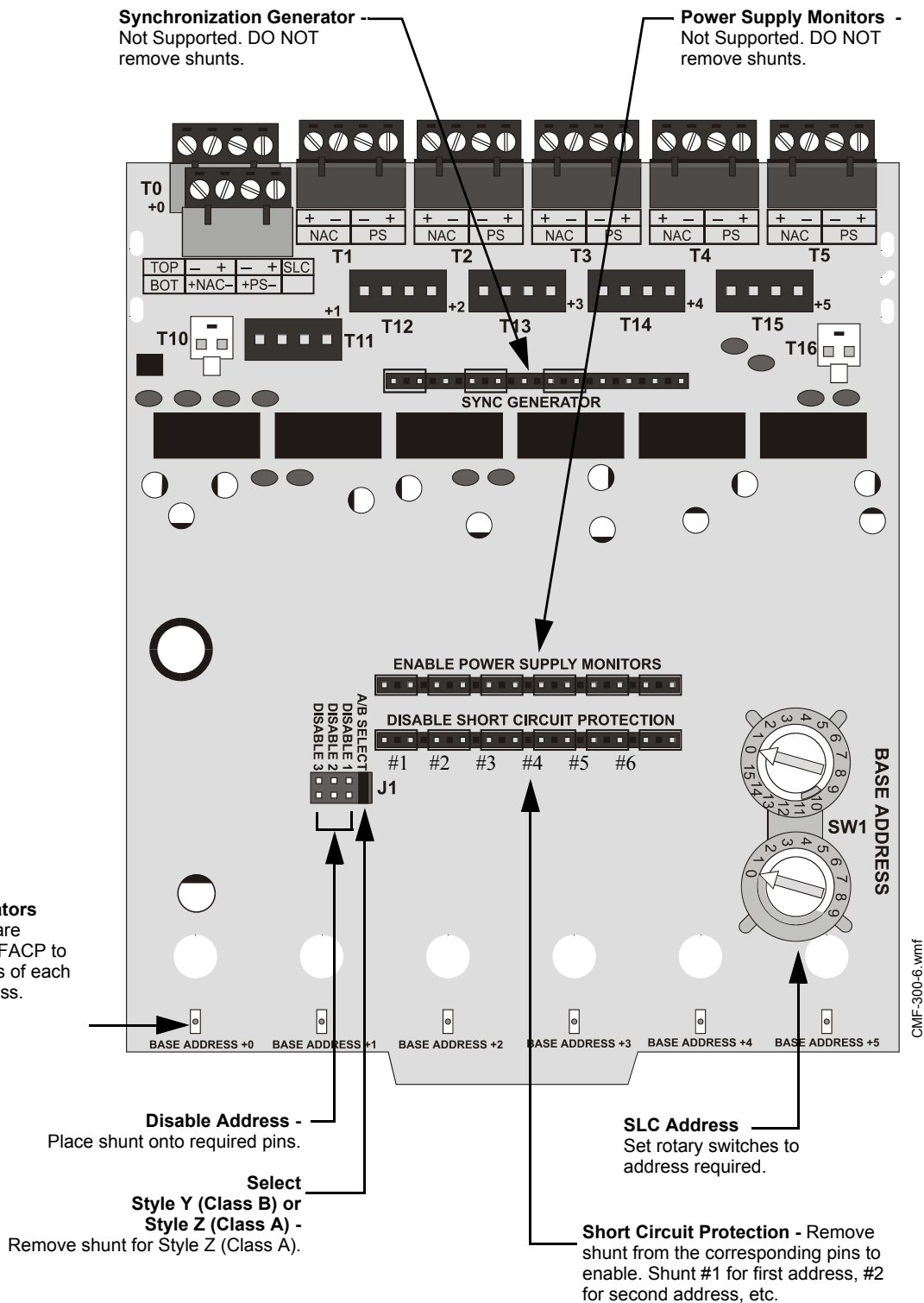

Figure 6.4 CMF-300-6 Control Module Settings

6.5 Wiring a CMF-300-6 Module

This section contains basic instructions and diagrams for wiring a Signaling Line Circuit with a CMF-300-6 as a Notification Appliance Circuit (NAC).

For more detailed information on wiring a CMF-300-6 Control Module, refer to the Installation Instructions provided with the module. Included in these instructions are wiring diagrams concerning a single power supply being shared by multiple NACs and audio NAC configurations.

6.5.1 Wiring a Style Y NAC (Two-Wire)

A supervised and power-limited NFPA Style Y (Class B) NAC with a single power supply dedicated to a single NAC using a CMF-300-6 module. Polarized alarm notification appliances are shown connected to the module in a two-wire configuration.



NOTE: Refer to the *Device Compatibility Document* for compatible notification appliances and relays.

- See “Power Considerations” on page 63 for information on monitoring 24 VDC power.
- Each module can control 2 amps of resistive load (on electronic devices) or 1 amp of inductive load (on mechanical bells and horns).
- 24 VDC power must be provided from a UL listed power supply for fire protection use.
- A power supervision relay is required only on the last module of the power run.
- Do not T-tap or branch a Style Y circuit.
- Terminate the circuit across the last device using an End-of-Line Resistor 47K, 1/2-watt, P/N SSD A2143-00 (ELR-47K in Canada).
- Do not loop wiring under the screw terminals of any notification appliance. To maintain supervision, break the wire run at each device.

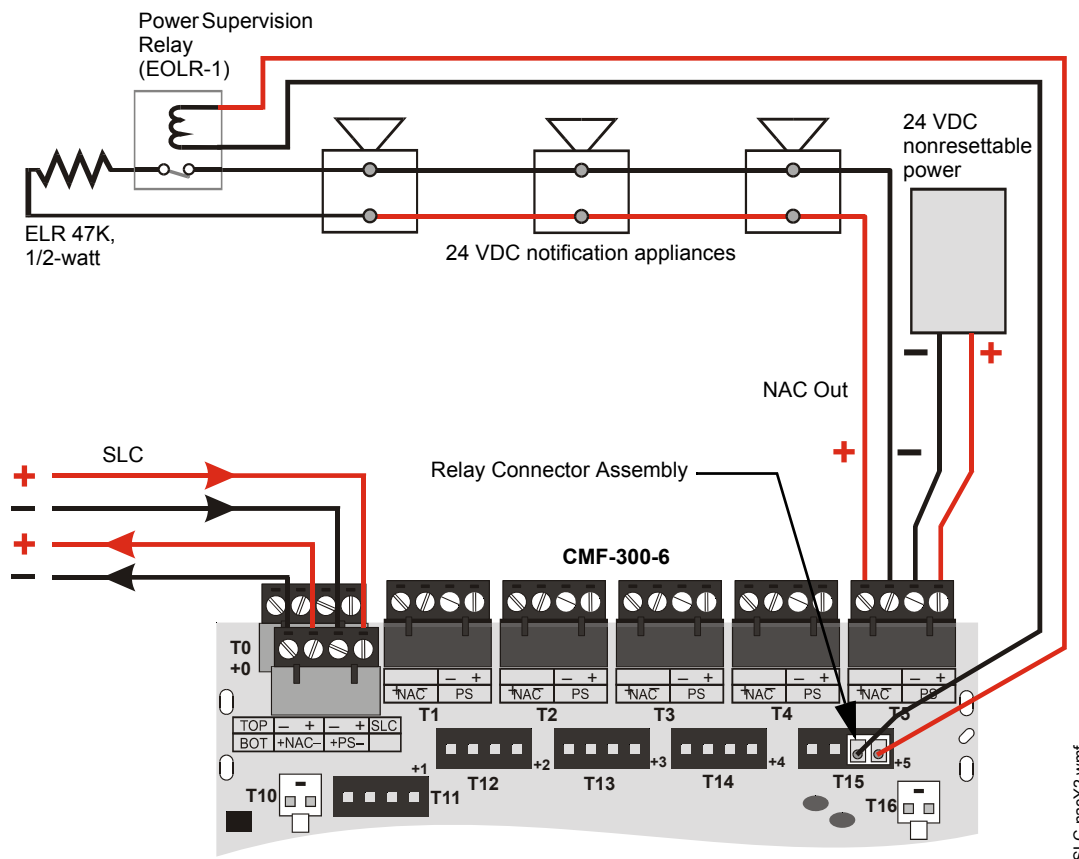

Figure 6.5 NFA Style Y Notification Appliance Circuit

6.5.2 Wiring a Style Z NAC (Four-Wire)

A supervised and power-limited NFPA Style Z (Class A) NAC with a single power supply dedicated to a single NAC using a CMF-300-6 module. Polarized alarm notification appliances are shown connected to the module in a four-wire configuration.



NOTE: Refer to the *Device Compatibility Document* for compatible notification appliances and relays.

- See “Power Considerations” on page 63 for information on monitoring 24 VDC power.
- Each module can control 2 amps of resistive load (on electronic devices) or 1 amp of inductive load (on mechanical bells and horns).
- 24 VDC power must be provided from a UL listed power supply for fire protection use.
- A power supervision relay is required only on the last module of the power run.
- Do not T-tap or branch a Style Z circuit.
- Do not loop wiring under the screw terminals of any notification appliance. To maintain supervision, break the wire run at each device.

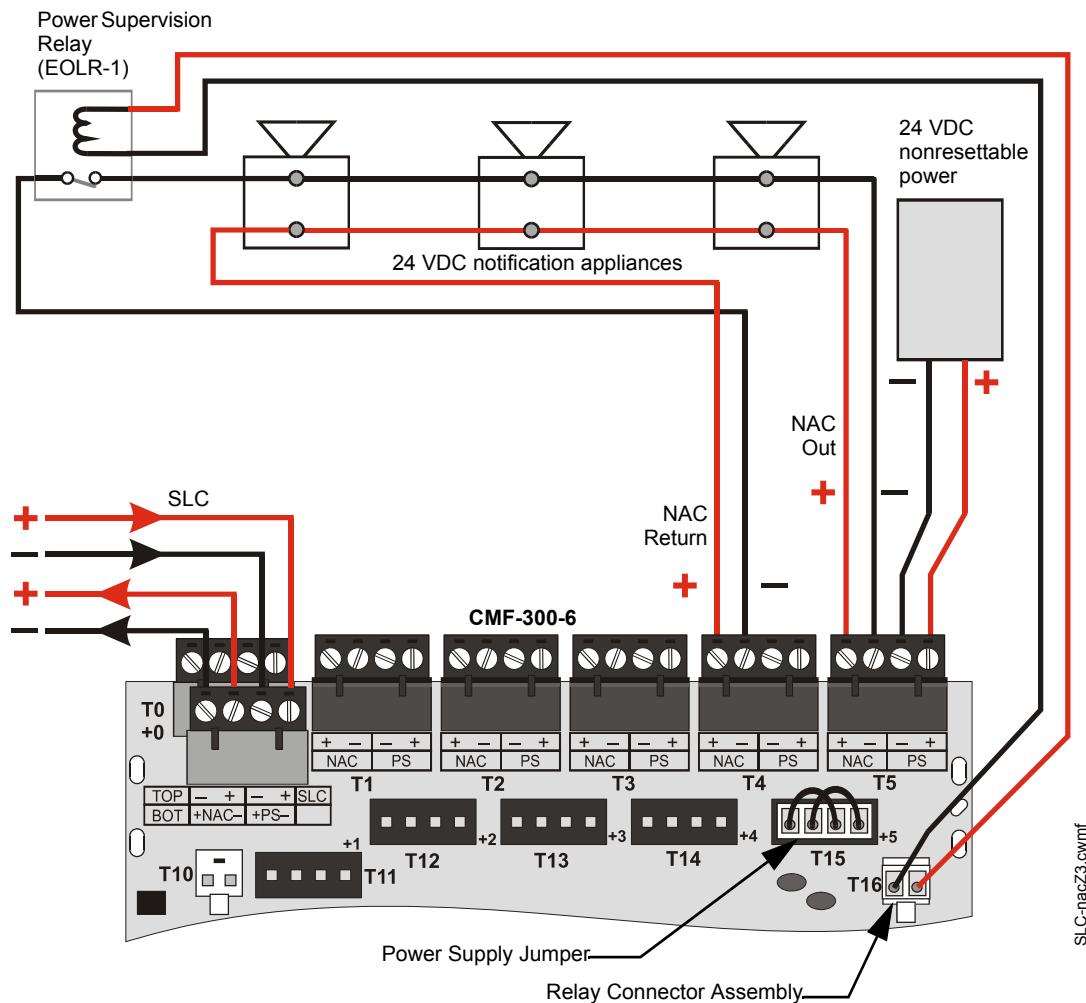

Figure 6.6 NFPA Style Z Notification Appliance Circuit

Section 7: Relay Modules

7.1 Description

The CRF-300 and the CRF-300-6 modules are addressable modules that provides Form-C relay contacts. Ratings for the relay contacts on the module are:

Load Description	Application	Maximum Voltage	Current Rating
Resistive	Non-Coded	30 VDC	3.0 A
Resistive	Coded	30 VDC	2.0 A
Resistive	Non-Coded	110 VDC	0.9 A
Resistive	Non-Coded	125 VAC	0.9 A
Inductive (L/R = 5ms)	Coded	30 VDC	0.5 A
Inductive (L/R = 2ms)	Coded	30 VDC	1.0 A
Inductive (PF = 0.35)	Non-Coded	70.7 VAC	0.7 A
Inductive (PF = 0.35)	Non-Coded	125 VAC	0.5 A



NOTE: For more information on the module specifications refer to the *Installation Instructions* provided with these devices.

7.2 CRF-300 Installation & Wiring

7.2.1 Setting an SLC address for a CRF-300 Module

Each module is factory preset with an address of “00”. To set an SLC address, refer to “Setting an SLC address for a Single Point Module” on page 33.

7.2.2 Wiring a CRF-300 Module (Form-C Relay)

The figure below shows a CRF-300 module wired to the Control Panel:

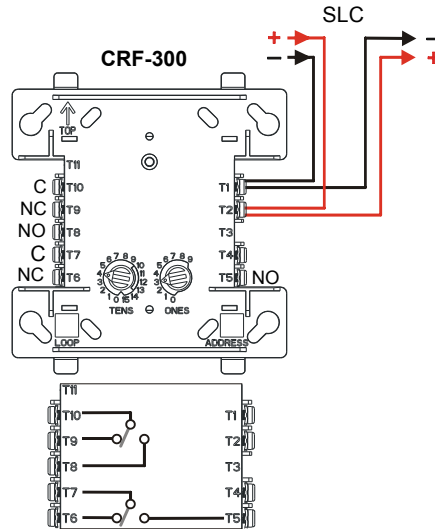

SLC-fmCipH.wmf

Figure 7.1 CRF-300 Wiring Connections

7.3 CRF-300-6 Circuit Board Information

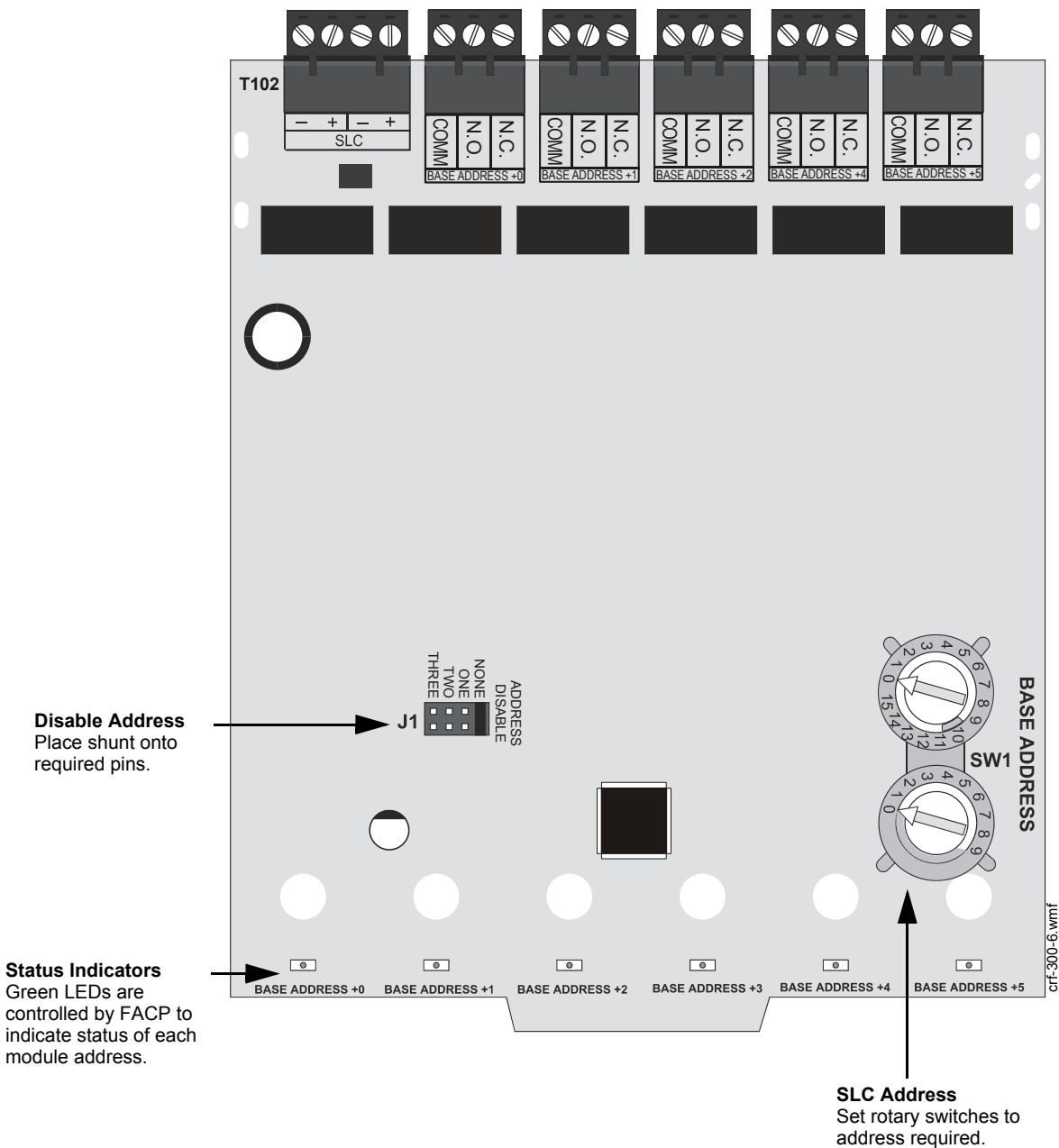

Figure 7.2 CRF-300-6 Control Relay Module

7.4 CRF-300-6 Installation & Wiring

7.4.1 Cabinet Installation

This type of module is contained in either a BB-2 or BB-6 cabinet. The BB-2 can accommodate up to 2 modules and the BB-6, which requires the CH-6 chassis, can accommodate up to 6 modules.

See the *Installation Instructions* provided with module for proper installation into cabinet.

7.4.2 Setting an SLC address for a CRF-300-6 Module

Each CRF-300-6 module can be set to one of 154 base addresses (01-154). The remaining module points are automatically assigned to the next five higher SLC addresses. For example, if the base address is set to 28, the next five module points will be addressed to 29, 30, 31, 32 and 33.

DO NOT set the lowest address above 154 (45 for the MS-9050UD and ES-50X, 94 for the MS-9200, MS-9200UD, MS-9200UDLS, and ES-200X), as the other module points will be assigned to nonexistent addresses.



NOTE: The MS-9050UD and ES-50X can support addresses 01 - 50. The MS-9200, MS-9200UD, MS-9200UDLS, and ES-200X can support module addresses of 01 - 99. The MS-9600, MS-9600LS, and MS-9600UDLS can support module addresses 01 - 159. To set an SLC address, use a common screwdriver to adjust the rotary switches on the module to the desired address. See Figure 6.4 on page 47. For use with an MS-9600, MS-9600LS, MS-9600LSC, and MS-9600UDLS, remove the stop on the upper rotary switch.

7.4.3 Disabling Unused Module Addresses

A shunt is provided on the circuit board to disable a maximum of three (3) unused module addresses. If two module addresses are disabled, the lowest four addresses will be functional, while the highest two will be disabled. For example, if the shunt is placed on 'TWO' and the base address is set to 28, the module addresses will be assigned to 28, 29, 30 and 31.

To disable addresses, remove the shunt from its storage location and securely place it onto the desired set of pins.

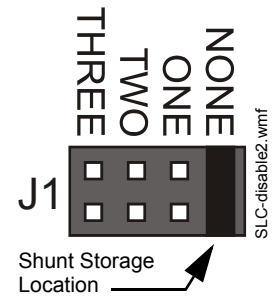

7.4.4 Wiring a CRF-300-6 Module (Form-C Relay)

The figure below shows a CRF-300-6 module wired to the Control Panel.

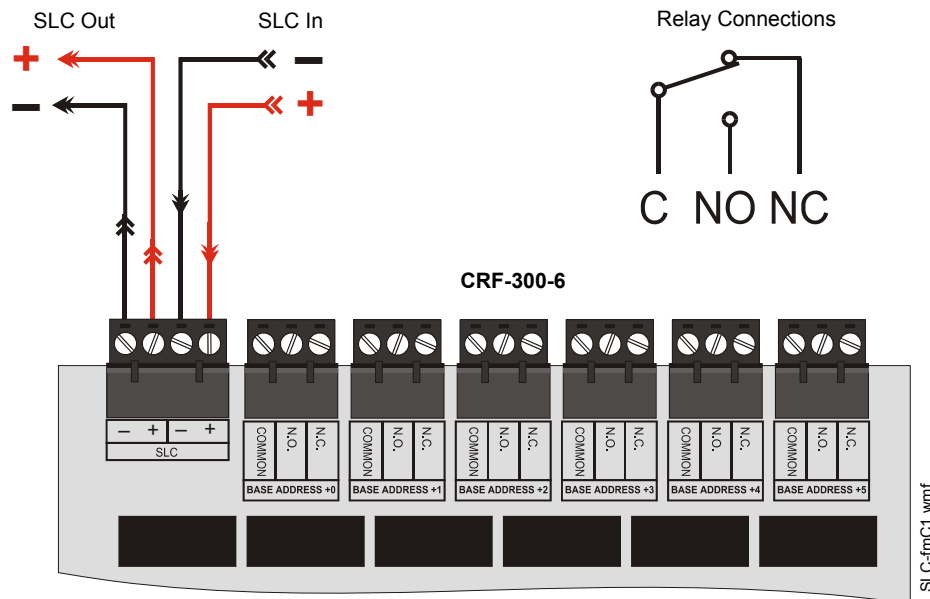

Figure 7.3 CRF-300-6 Wiring Connections

Section 8: Multiple Input/Output Modules

8.1 Description

The CDRM-300 is an addressable module that functions as two individual relay control modules (two isolated sets of Form-C relay contacts) and two Class B monitor modules.

Ratings for the relay contacts on the module are:

Load Description	Application	Maximum Voltage	Current Rating
Inductive (PF = 0.35)	Non-Coded	25 VAC	2.0 A
Resistive	Non-Coded	30 VDC	3.0 A
Resistive	Coded	30 VDC	2.0 A
Inductive (L/R = 20ms)	Non-Coded	30 VDC	0.46 A
Inductive (PF = 0.35)	Non-Coded	70.7 VAC	0.7 A
Resistive	Non-Coded	125 VDC	0.9 A
Inductive (PF = 0.75)	Non-Coded	125 VAC	0.5 A
Inductive (PF = 0.35)	Non-Coded	125 VAC	0.3 A



NOTE: For more information on the module specifications refer to the *Installation Instructions* provided with these devices.

8.2 CDRM-300 Installation & Wiring

8.2.1 Setting an SLC address for a CDRM-300 Module

Each module is factory preset with an address of “00”. To set an SLC address, use a screwdriver to adjust the rotary switches on the module to the desired address. Each module can use up to four (4) addresses. The base address selected via the rotary address switches will be assigned to relay output #1 from 00 to 156. The module will automatically assign the next three addresses as appropriate to monitored input #1, relay output #2, and monitored input #2.

8.2.2 Wiring a CDRM-300 Module (Form-C Relay)

The figure below shows a CDRM-300 module wired to the Control Panel.

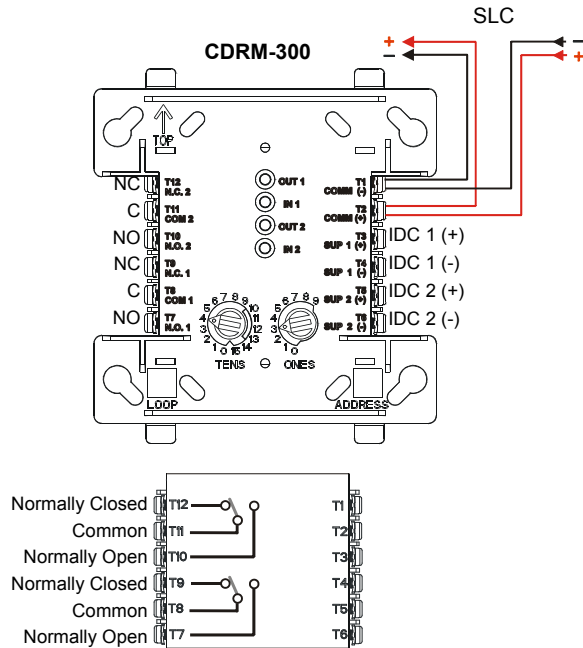

fdrm-1.wmf

Figure 8.1 CDRM-300 Wiring Connections

Section 9: Intelligent Detector Bases and Wireless Gateway

9.1 Description

The following bases provide connection between the SLC and these detector heads:

- AD350 and AD355 Multi-criteria Photoelectric Smoke Detectors
- CP350 and CP355 Ionization Smoke Detectors
- H350, H350R, H355, H355R, H355HT, H365(-IV), H365R(-IV), H365HT(-IV) Thermal Detectors
- SD350, SD350T, SD355, SD355T, SD365(-IV), and SD365T(-IV) Photoelectric Smoke Detectors

The **B501(-WHITE/-BL/-IV)**, **B210LP**, and **B300-6(-IV)** bases are standard plug-in detector bases.

The **B501BH**, **B501BHT**, **B501BH-2**, **B501BHT-2**, **B200S(-WH/-IV)**, **B200S-LF(-WH/-IV)**, **B200SR(-WH/-IV)**, and **B200SR-LF(-WH/-IV)** Sounder Detector Bases include a horn that will sound when the sensor's visible LEDs are latched on for approximately 10 seconds.

On the MS-9200 Control Panel, the sounder will activate when the sensor's visible LEDs are latched on for approximately 10 seconds (Alarm Verification does not delay sounder).

If the MS-9600, MS-9600LS, MS-9600UDLS, MS-9200UD, MS-9200UDLS, MS-9050UD, ES-50X, or ES-200X, Control Panel is set with Alarm Verification ON (enabled), the sounder will activate at the end of the verification cycle, providing an alarm is verified, approximately 10 seconds after the sensor's LEDs are latched on. If Alarm Verification is OFF (disabled), the sounder will activate when the sensor's visible LEDs are latched on for approximately 10 seconds.

The **B224RB(-WH/-IV)** Relay Detector Base includes Form-C latching relay contacts for the control of an auxiliary function. The relay operates 12 seconds (nominally) after activation of the sensor head remote annunciator output.

The **B224BI(-WH/-IV)** Isolator Detector Base prevents an entire communications loop from being disabled when a short circuit occurs.

The **W-GATE** Wireless Gateway acts as a bridge between a group of wireless fire devices and a LiteSpeed SLC loop on the ES-50X, ES-200X, or MS-9200UDLS. The gateway can be powered by the SLC loop or by a regulated, external UL-listed, 24VDC power supply. See Section 9.7.



NOTE: When using a Wireless Gateway on the SLC loop, the panel cannot have ANY modules (wired or wireless) in the address range from 140 to 159.

For details about the wireless network and its devices, see the *SWIFT™ Smart Wireless Integrated Fire Technology Instruction Manual #LS10036-000FL-E*.

9.2 Setting the Detector Address

Each intelligent detector is factory preset with an address of "00." To set an SLC address, use a common screwdriver to adjust the rotary switches on the detector to the desired address (see "Setting an SLC address for a Single Point Module" on page 33). When finished, mark the address in the place provided on the base and the detector.

9.3 Wiring a Detector Base

Typical wiring of a detector base (**B501** shown) connected to an SLC is shown in the figure below. An optional **RA100Z/RA400Z** Remote LED Annunciator is shown connected to the detector.

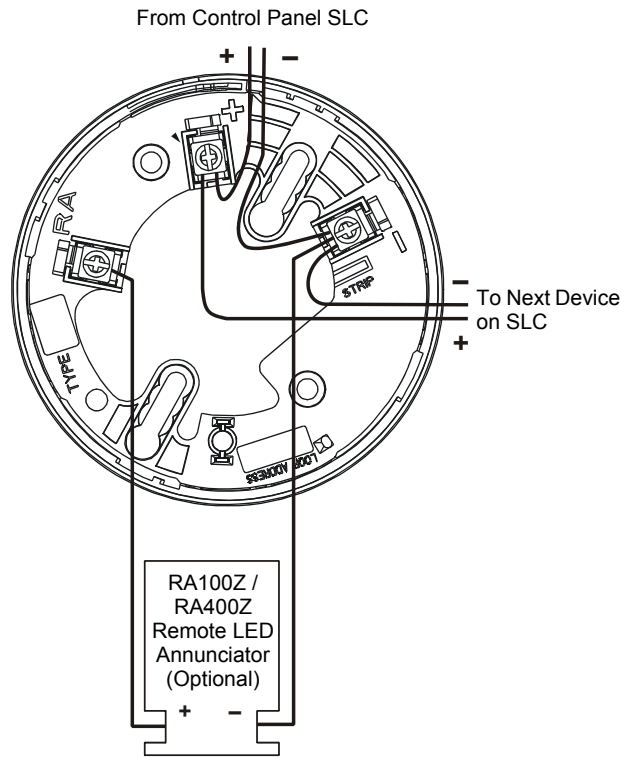

SLC-B5012wire.wmf

Figure 9.1 Wiring a B300-6, B210LP, or B501 Detector Base



NOTE: The B300-6 and B210LP base wiring is identical to the B501. B501 is the flangeless model.

9.4 Wiring an Isolator Base

The **B224BI** Isolator Base will isolate its detector from short circuits that occur on the SLC connected at terminals 2 and 3. It will not isolate its installed detector from short circuits that occur on the SLC connected at terminals 1 and 2. In Style 7 applications, the loss of a single detector during a short circuit is not acceptable, and an isolator module must be installed as shown in the figure below.

Note: The “grid” pattern on the redesigned B224BI mounting plate has been removed for illustration purposes only.

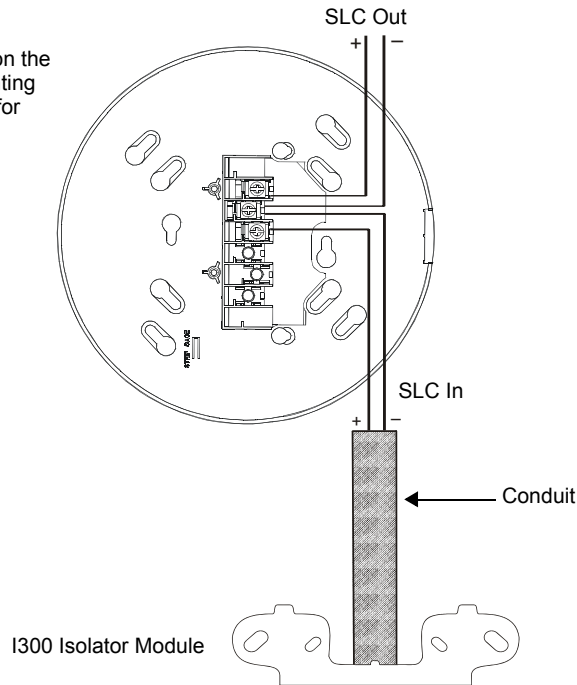

slc-b224bi2wire.wmf

Figure 9.2 Wiring of a B224BI Isolator Base Mounting Plate

9.5 Wiring a Relay Base

Figure 9.3 shows typical wiring of a **B224RB** plug-in relay detector base connected to an SLC.

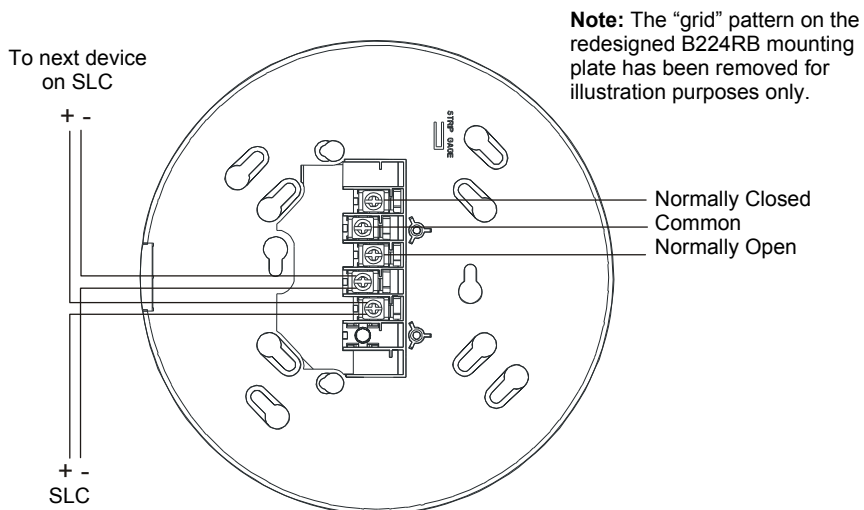

slc-b224rb2wire.wmf

Figure 9.3 Wiring of a B224RB Relay Base Mounting Plate

9.6 Wiring a Sounder Base

Figure 9.4 shows typical wiring of the **B200S**, **B200S-LF**, **B200SR**, or **B200SR-LF** Sounder Base.

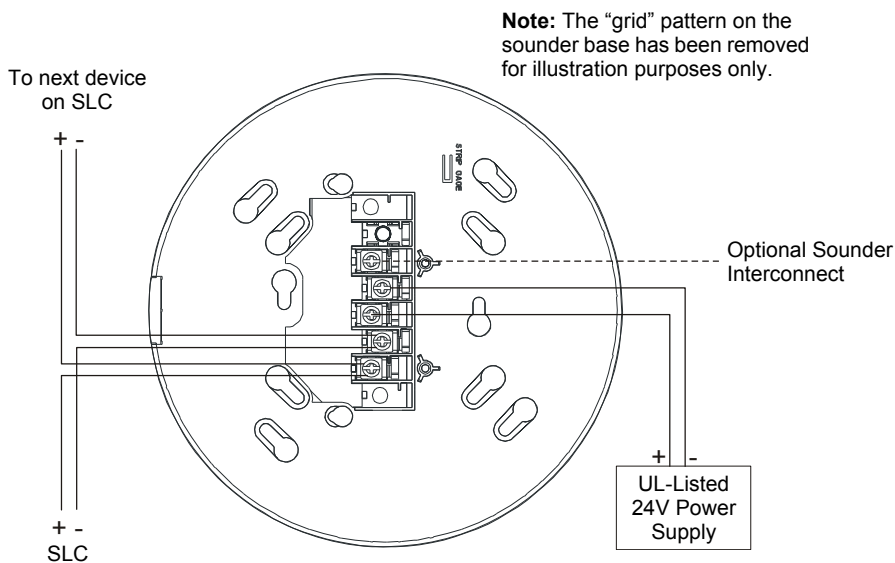

Figure 9.4 Wiring of a B200S(R)/B200S(R)-LF Sounder Base



NOTE: For more detailed wiring on the sounder base, refer to the device's installation instructions.

9.7 Wiring the W-GATE



NOTE: The W-GATE, as part of the wireless network, has been tested for compliance with the Federal Communications Commission (FCC) requirements of the United States Government. It has not been evaluated for use outside the USA. Use of this system outside the USA is subject to local laws and rules to which this product may not conform. It is the sole responsibility of the user to determine if this product may be legally used outside the USA.



NOTE: It is recommended to use the same wire gauge if there are multiple connections to the same terminal.

9.7.1 SLC Connections

The W-GATE Wireless Gateway acts as a bridge between a group of wireless fire devices and a LiteSpeed SLC loop on the ES-50X, ES-200X, or MS-9200UDLS. It is powered by the SLC loop or by a regulated, external 24VDC UL-listed power supply. Available wireless devices include a photo detector, a photo/heat detector, a fixed-temperature heat detector, a rate-of-rise heat detector, and a monitor module. For details about wireless devices, system setup, and operation, see the *SWIFT™ Smart Wireless Integrated Fire Technology Instruction Manual*.

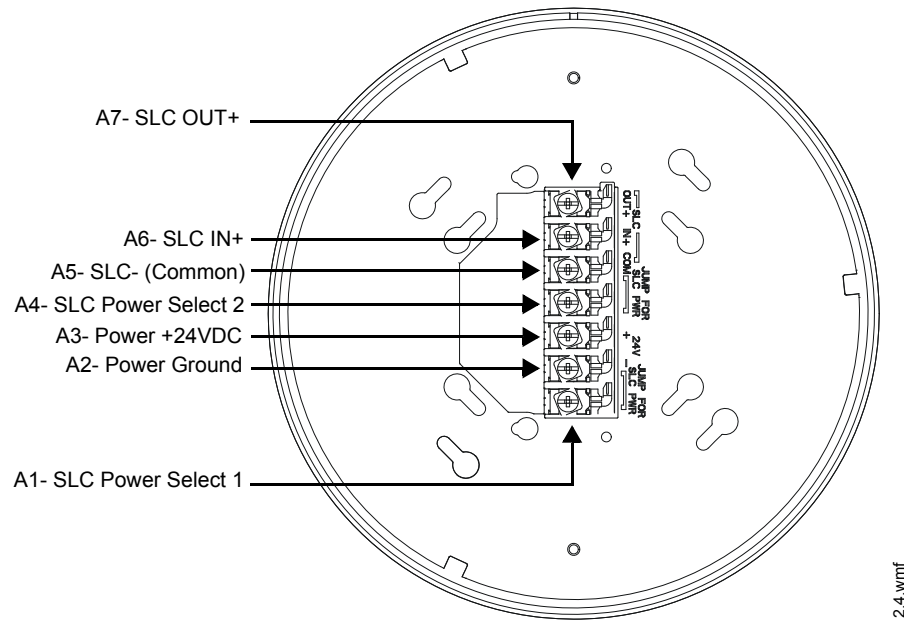

Figure 9.5 W-GATE Mounting Plate - Terminal Layout

9.7.2 W-GATE Powered by the SLC

The W-GATE provides isolation of short circuits on the SLC in Class A (Style 6) installations. SLC connections are power-limited by the panel. An interruption in the SLC that causes a loss of power at the W-GATE for more than 100ms may result in a trouble condition and loss of fire protection provided by the wireless devices for approximately 15 minutes. Use of a regulated, external +24VDC power source (not SLC power) is recommended for installations that require fire protection in the presence of short circuits, including Class A applications and applications that use isolator modules. Figure 9.6 shows typical wiring of a Wireless Network Gateway connected to an SLC when power is supplied by the SLC loop

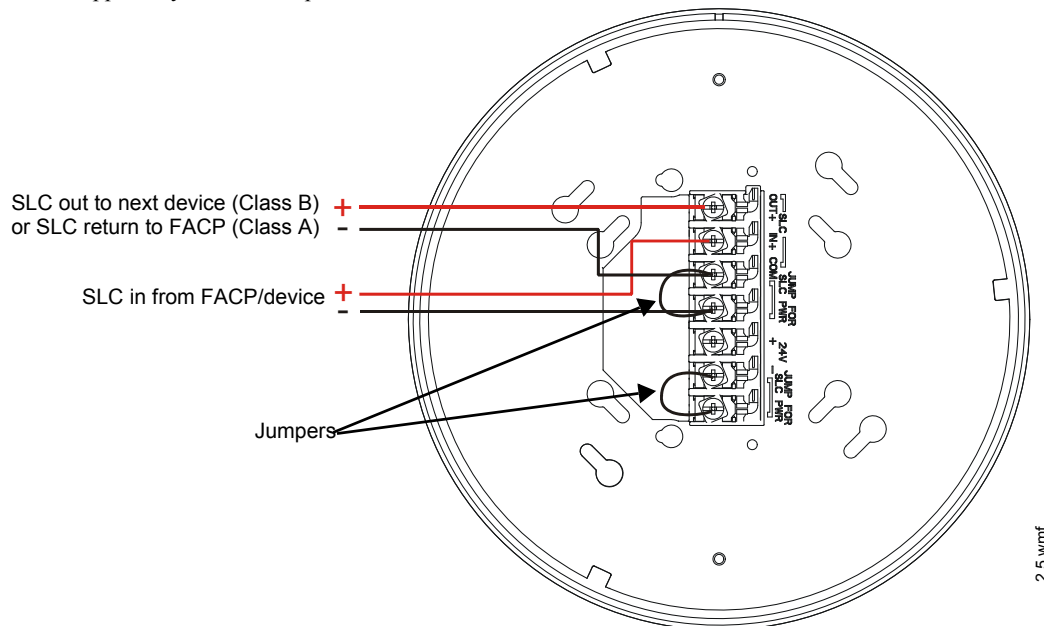

Figure 9.6 W-GATE Powered by the SLC

9.7.3 W-GATE Powered by a Regulated, External +24VDC Power Source

The W-GATE provides isolation of short circuits of the SLC in Class A (Style 6) installations. SLC connections are power-limited by the panel. +24VDC must be power-limited by the source..

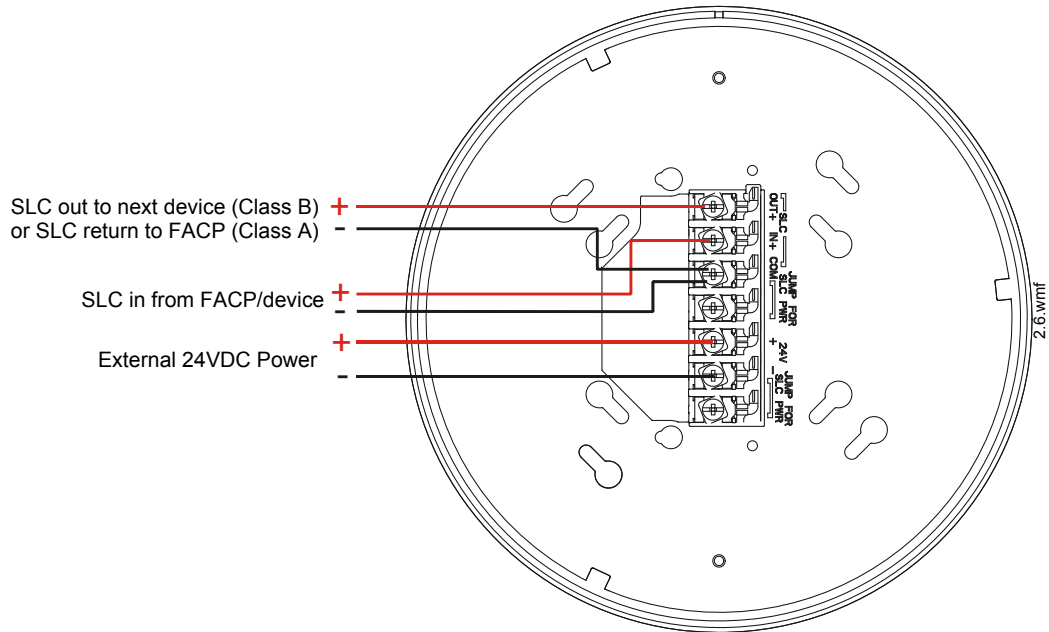

Figure 9.7 W-GATE Powered by a Regulated, External Source

Section 10: Addressable Beam Detectors

10.1 Description

The **BEAM355**, **BEAM355S**, and **OSI-RI-FL** are intelligent, addressable projected beam smoke detectors, designed for protecting open areas with high and sloping ceilings and wide-open areas, where spot type smoke detectors are difficult to install and maintain. The **BEAM355S** has an integral sensitivity test feature that consists of a test filter attached to a servomotor inside the detector optics.



NOTE: This section provides basic wiring and addressing information For **critical information** on device installation, operation and alignment, refer to the *Installation Instructions* provided with these devices.

10.2 Installation and Wiring

10.2.1 Setting an SLC Address for a Beam Detector

Each beam detector is factory preset with an address of “00.” To set an SLC address, use a common screwdriver to adjust the address rotary code switches on the detector to the desired address (refer to 5.2.1 “Setting an SLC address for a Single Point Module” on page 33).

10.2.2 Wiring a Beam Detector

Typical wiring of a BEAM355 beam detector connected to an SLC is illustrated in the figure below.

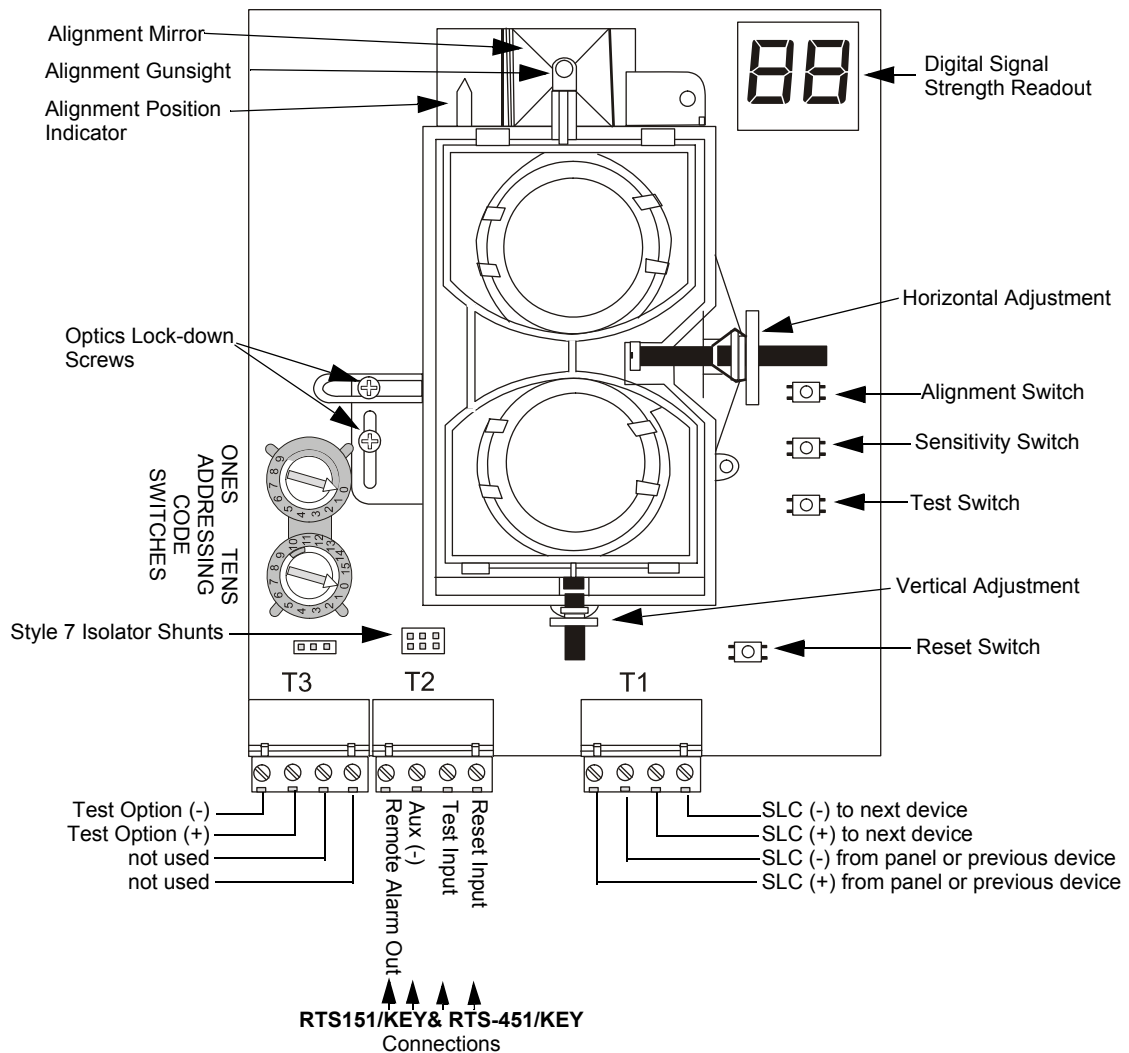

Figure 10.1 BEAM355 Beam Detector Terminal Block Wiring

Typical wiring of an OSI-RI-FL beam detector connected to an SLC is illustrated in the figure below.

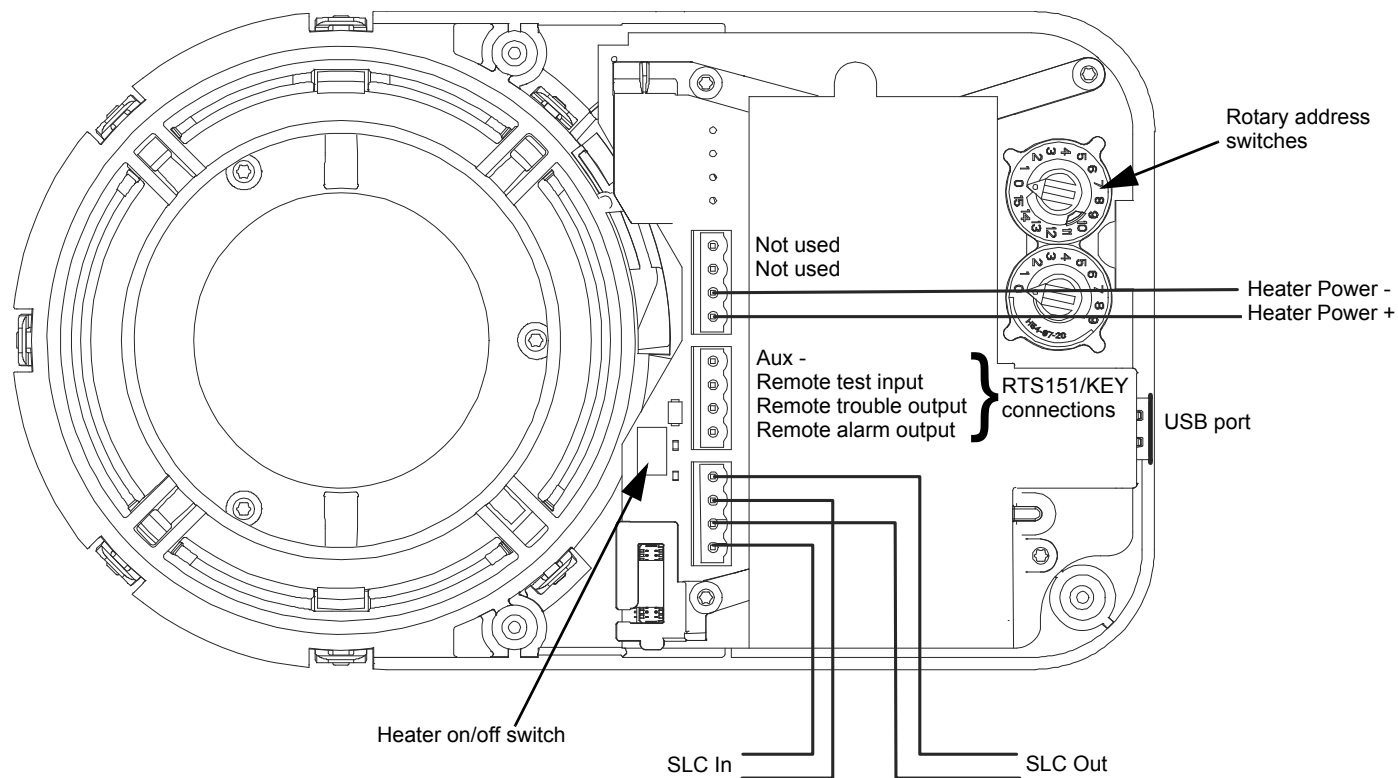

Figure 10.2 OSI-RI-FL Beam Detector Terminal Block Wiring

Section 11: Addressable Manual Pull Station

11.1 Description

The BG-12LX is an addressable manual pull station with a key-lock reset feature.



NOTE: For more information refer to the *Installation Instructions* provided with this device.

11.2 Installation

11.2.1 Setting an SLC address

Each unit is factory preset with an address of “00.” To set an SLC address refer to “Setting an SLC address for a Single Point Module” on page 33.

11.2.2 Wiring a Manual Pull Station

Figure 11.1 shows typical wiring for a BG-12LX Manual Pull Station to an SLC:

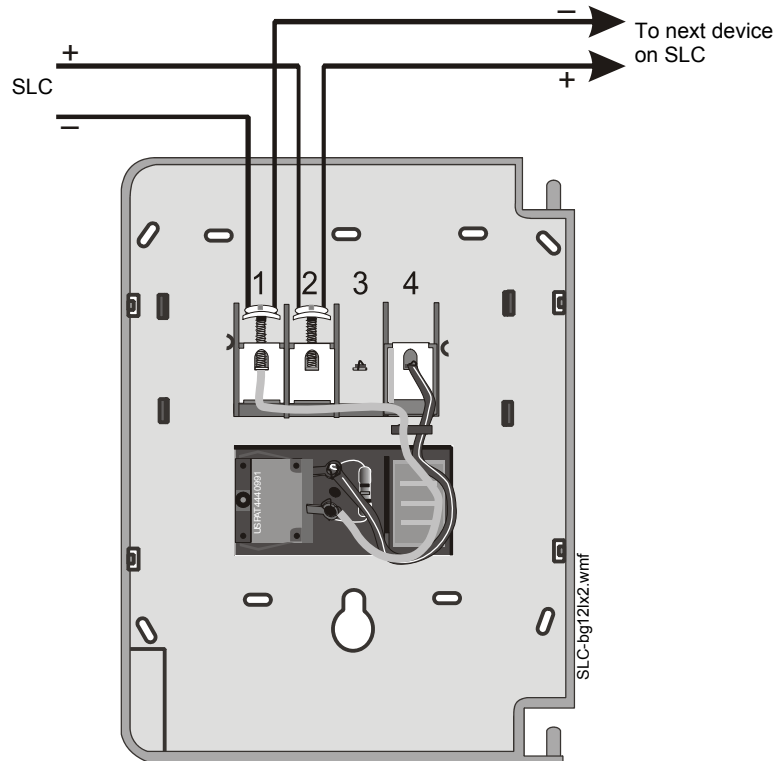

Figure 11.1 Wiring of a BG-12LX Pull Station to an SLC

Appendix A: Power Considerations

A.1 Supplying Power to 24 VDC Detectors and NACs

A.1.1 Resistance and Size

To determine the minimum resistance that can be tolerated in supplying power to 24 VDC 4-wire devices and NACs, use the calculation below. Use this resistance to select the proper gauge wire for the power run from the manufacturer's specifications for the desired wire.

For Four-Wire Detectors:

$$R_{max} = \frac{(V_{ms} - V_{om})}{(N)(I_s) + (N_a)(I_a) + (I_r)}$$

For NACs:

$$R_{max} = \frac{(V_{ms} - V_{om})}{(N_b)(I_b)}$$

Where:

R_{max} = maximum resistance of the 24 VDC wires

V_{ms} = minimum supply voltage

V_{om} = minimum operating voltage of the detector or end-of-line relay, whichever is greater, in volts

N = total number of detectors on the 24 VDC supply circuit

I_s = detector current in standby

N_a = number of detectors on the 24 VDC power circuit which must function at the same time in alarm

I_a = detector current in alarm

I_r = end-of-line relay current

N_b = number of Notification Appliance Devices

I_b = Notification Appliance current when activated



NOTE: This simplified equation assumes that the devices are at the end of a long wire run.

The minimum supply voltages produced by Fire•Lite power supplies are listed below:

FACP	V _{ms}	Power Supply	V _{ms}
MS-9200	16.0	FCPS-24F	19.1
MS-9600	16.0	FCPS-24FS6/FCPS-24FS8	19.1
MS-9200UD/MS-9200UDLS	19.05		
MS-9050UD	18.75		
ES-50X	19.2		
ES-200X	19.2		

Table A.1 Minimum Supply Voltage

A.2 Supervising 24 VDC Power

Power used to supply 24 VDC detectors, notification appliances (using the CMF-300), and two wire detectors (using the MMF-302) can be supervised with a power supervision relay. This relay, energized by the 24 VDC power itself, is installed at the end of each respective power run and wired in-line with the supervised circuit of any intelligent module.

24 VDC power must be provided from a UL-listed power supply for fire protection use.

When power is removed from the relay, the normally closed contacts open the supervised circuit, generating a trouble condition. Therefore, the relay needs to be installed at the end of the supervised circuit, so it will not disrupt the operating capability of all the devices on that circuit. The relay can be installed in-line with any leg (+ or -) of the supervised NAC circuit, either a Style B (Class B) or a Style D (Class A) circuit.

The drawing below illustrates this concept.

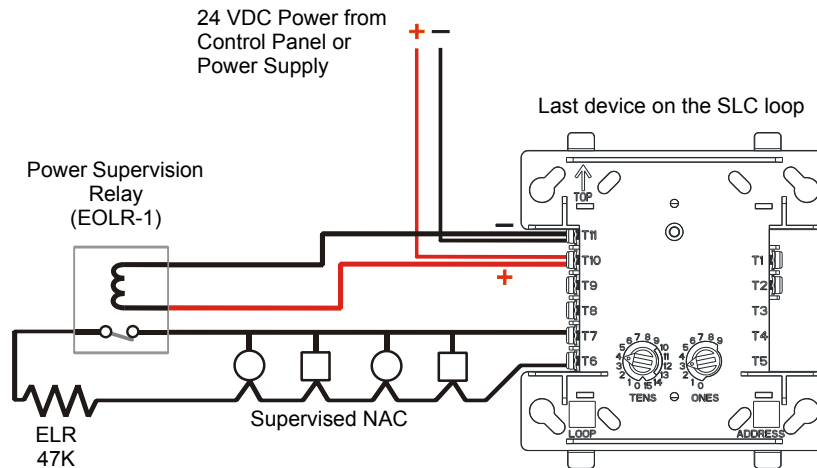

SLC-psrtpH.cdr

Figure A.1 Supervised 24 VDC Circuit

An alternate method is shown below.

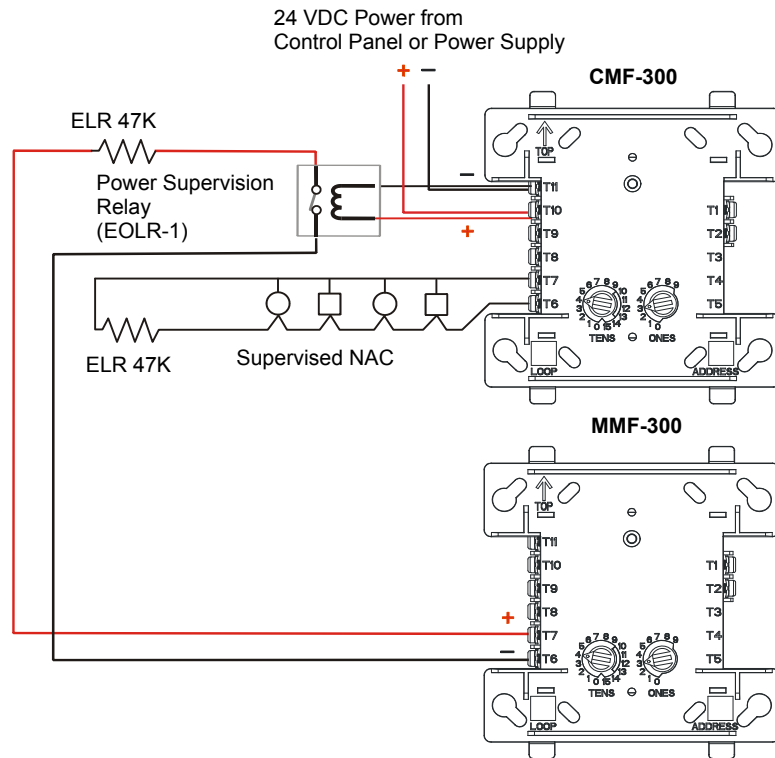

SLC-psr-2addresstpH.wmf

Figure A.2 Alternate: 2-Address Method of Supervising a 24 VDC Circuit

Appendix B: Surge Suppression

B.1 Introduction



NOTE: Surge protection is *not* required in Canadian applications.

There are three (3) primary surge protectors that are approved for use with the MS-9200, MS-9200UD, MS-9200UDLS, MS-9600, MS-9600LS, MS-9600UDLS, and MS-9050UD.

- **DTK-2LVLP-F** Diversified Technology Group, Inc. 1720 Starkey Rd. Largo, FL 33771 (727) 812-5000
- **SLCP-30** EDCO 1805 N.E. 19th Ave. Ocala, FL 34470 (352) 732-3029
- **PLP-42N** Northern Technologies, Inc. 23123 E. Madison Ave. Liberty Lake, WA 99019 (800) 727-9119



NOTE: For detailed information, refer to the *Installation Instructions* supplied with the unit.

One primary surge protector must be used with each SLC wiring pair whenever SLC wiring runs outside the building.

- Install primary protection only as shown in this document.
- Refer to NEC Article 800 and local building code requirements.

Additional primary surge suppressors may be added as required by the NEC. Add these additional suppressors in series with the SLC wiring at the building entry/exit.

Wiring connected to the surge suppressor output must remain within the building while wiring connected to the surge suppressor input may be routed outside the building as shown below.

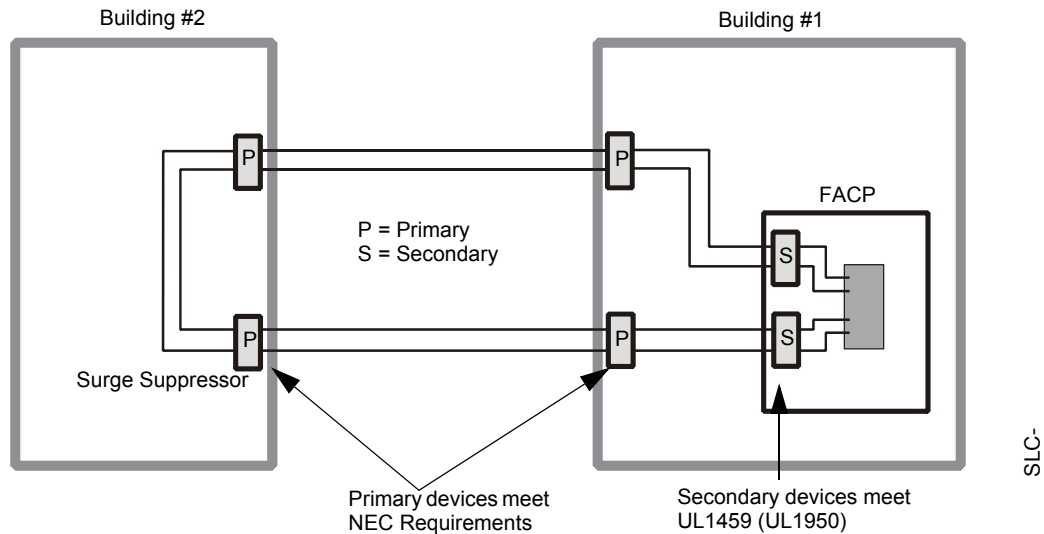

B.2 Installation

Mounting of the surge suppressor must be inside the FACP enclosure or in a separate enclosure listed for fire protective signaling use.

- Locate on an available stud and secure with nut.
- Unit is connected in series with the SLC Loop to protect the Control Panel.
- Provide a common ground to eliminate the possibility of a differential in ground potentials.

B.2.1 Wiring Diagram for MS-9200

DTK-2LVLP-F Connections

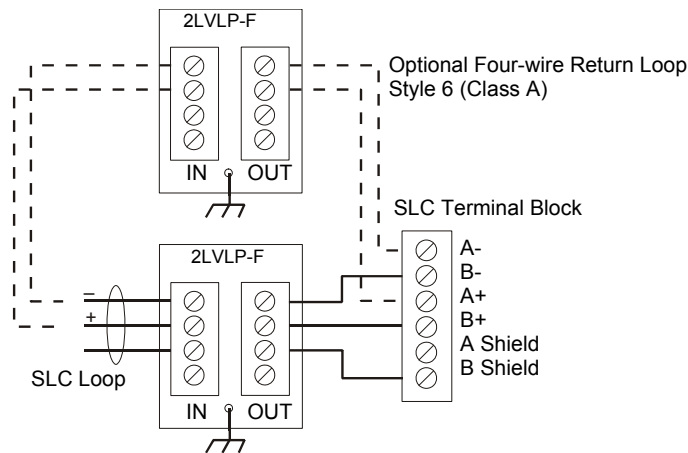

SLC-lvlp1.wmf

PLP-42N Connections

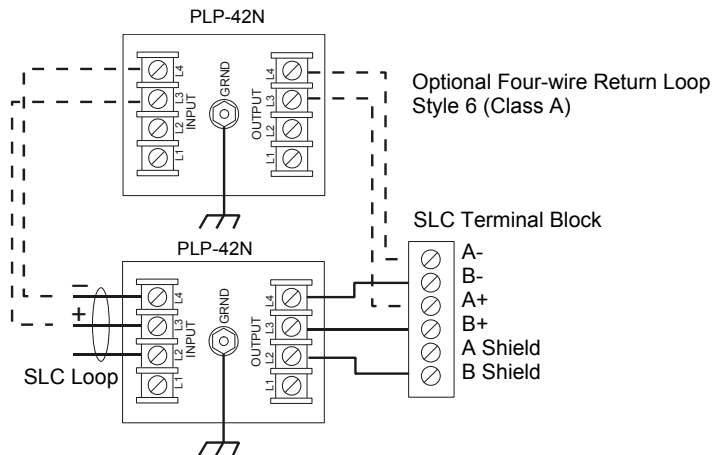

SLC-plpn1.wmf



NOTE: Use 12AWG (3.25mm²) to 18AWG (0.75mm²) wire with crimp-on connectors to connect the unit's ground terminal to equipment ground. Wire length must be minimized to provide best protection.

SLCP-30 Connections

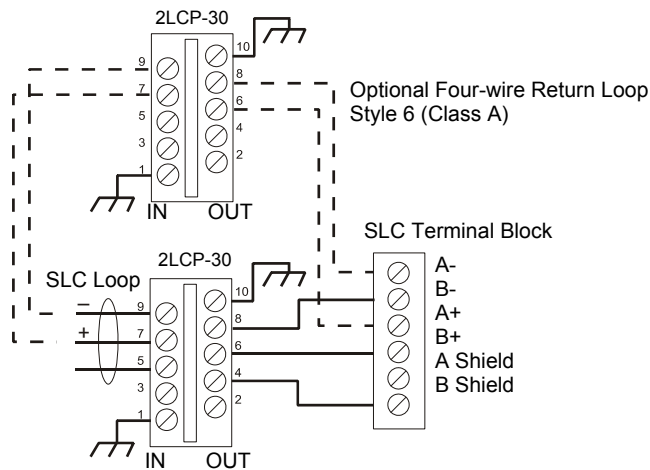

SLC-slcp1.wmf

B.2.2 Wiring Diagram for MS-9600, MS-9600LS, MS-9600UDLS, MS-9200UD, MS-9200UDLS, and MS-9050UD

DTK-2LVLP-F Connections

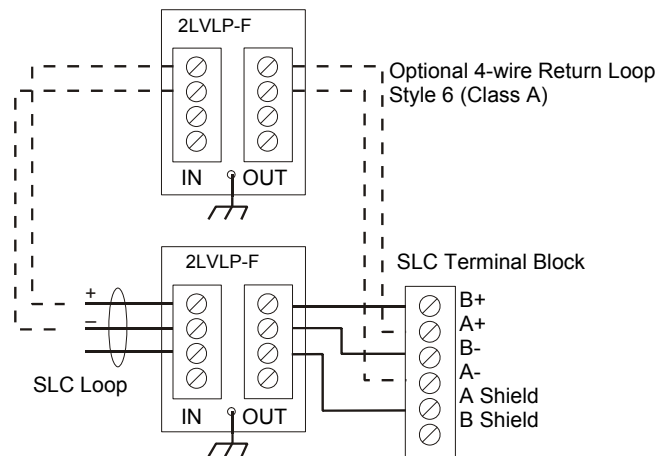

SLC-lvp4.wmf

PLP-42N Connections

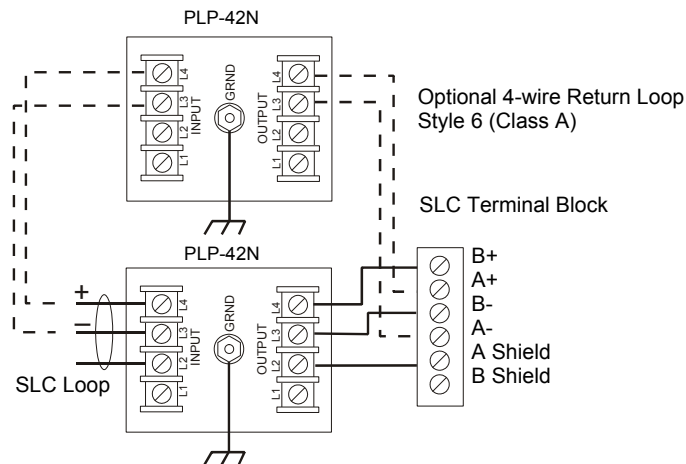

SLC-plpn4.wmf



NOTE: Use 12AWG (3.25mm²) to 18AWG (0.75mm²) wire with crimp-on connectors to connect the unit's ground terminal to equipment ground. Wire length must be minimized to provide best protection.

SLCP-30 Connections

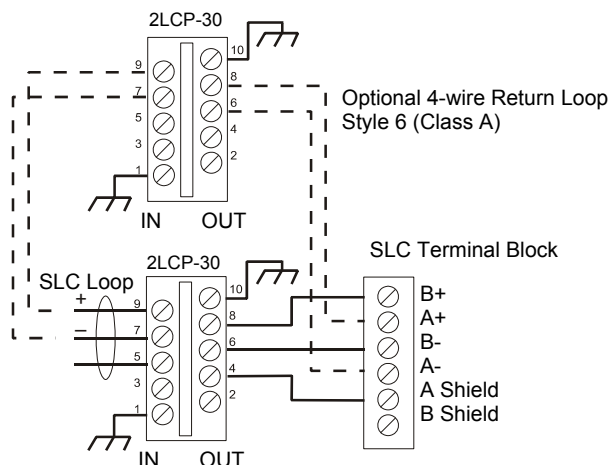

SLC-slcp4.wmf

B.2.3 Wiring Diagram for ES-50X and ES-200X

DTK-2LVLP-F Connections

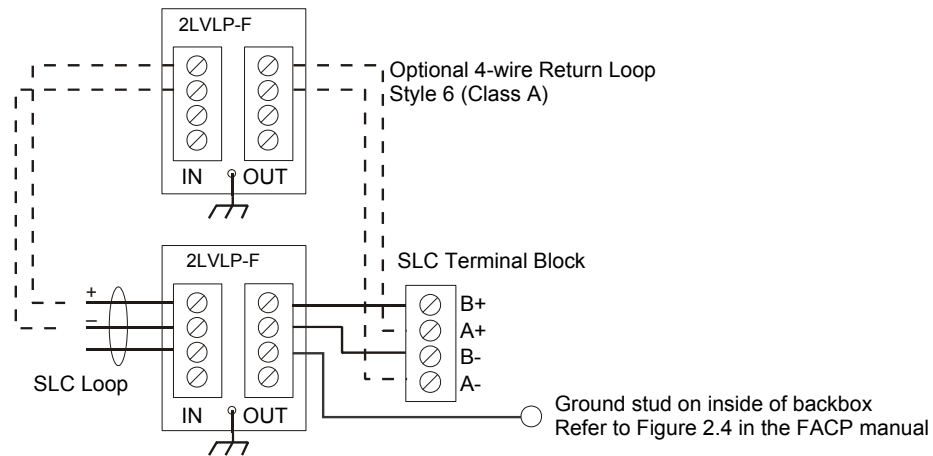

PLP-42N Connections

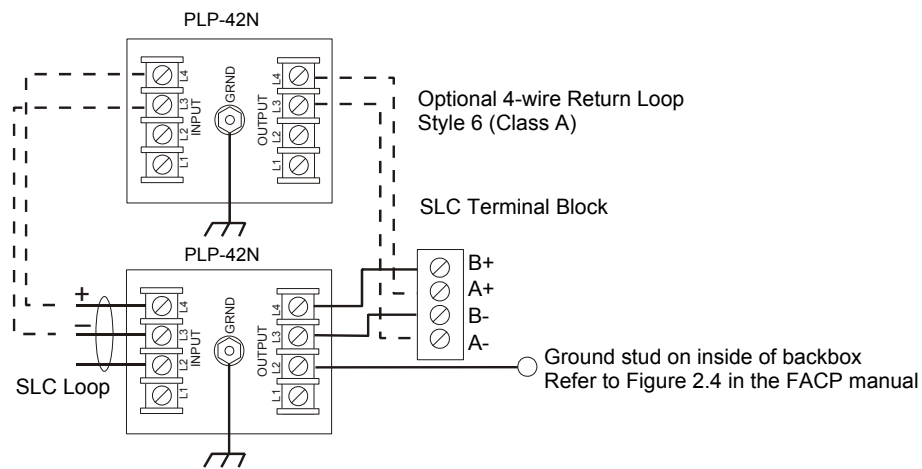

NOTE: Use 12AWG (3.25mm²) to 18AWG (0.75mm²) wire with crimp connectors to connect the unit's ground terminal to equipment ground. Wire length must be minimized to provide best protection.

SLCP-30 Connections

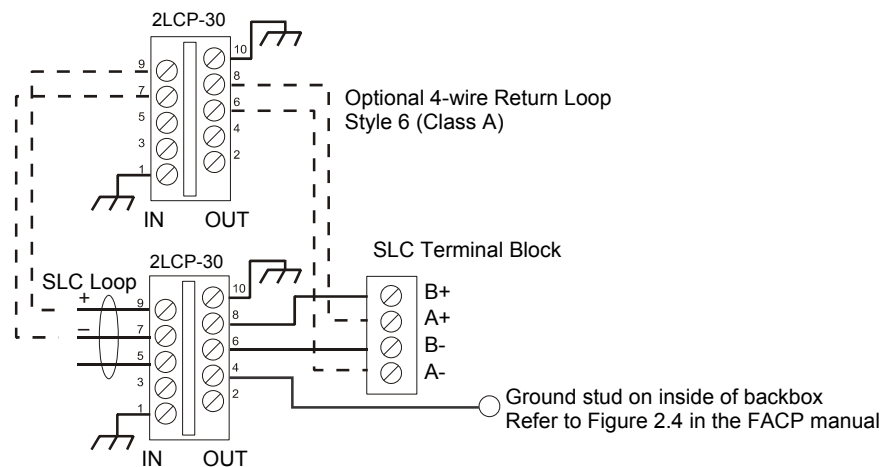

Appendix C: Terminal Conversion Charts for New & Legacy Devices

C.1 CRF-300

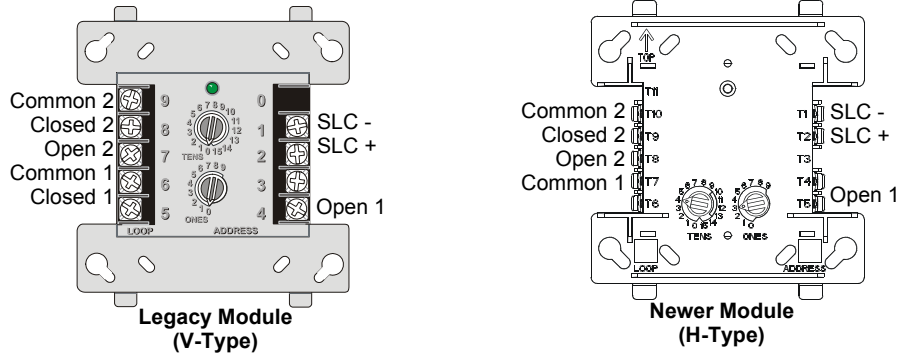

Legacy Module Terminal Number (V-Type)	Terminal Function	Newer Module Terminal Number (H-Type)
1	SLC -	1
2	SLC +	2
3	Unused	3
4	Normally Open (1)	5
5	Normally Closed (1)	6
6	Relay Common (1)	7
7	Normally Open (2)	8
8	Normally Closed (2)	9
9	Relay Common (2)	10
N/A	Unused	4
N/A	Unused	11

Table C.1 CRF-300 Terminal Conversions

C.2 CMF-300 and MMF-302

All module polarities are shown in **standby** condition, which reflects the labels on the new modules.

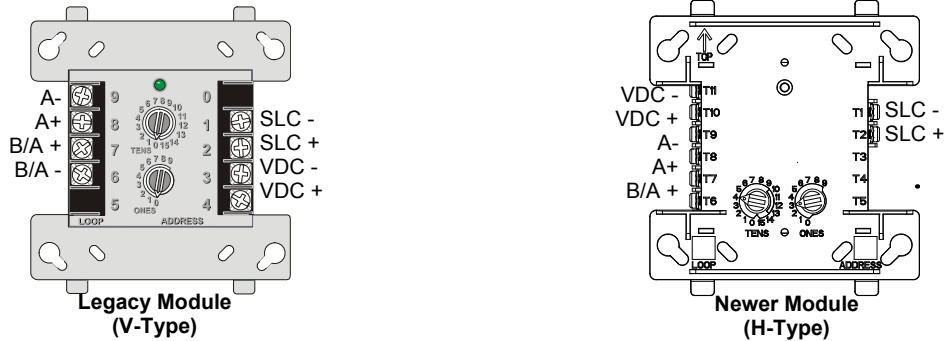

Legacy Module Terminal Number (V-Type)	Terminal Function	Newer Module Terminal Number (H-Type)
1	SLC -	1
2	SLC +	2
3	VDC -	11
4	VDC +	10
5	Unused	5
6	Solenoid B/A -	6
7	Solenoid B/A +	7
8	Solenoid A +	8
9	Solenoid A -	9
N/A	Unused	3
N/A	Unused	4

Table C.2 CMF-300 and MMF-302 Terminal Conversions

C.3 MMF-300

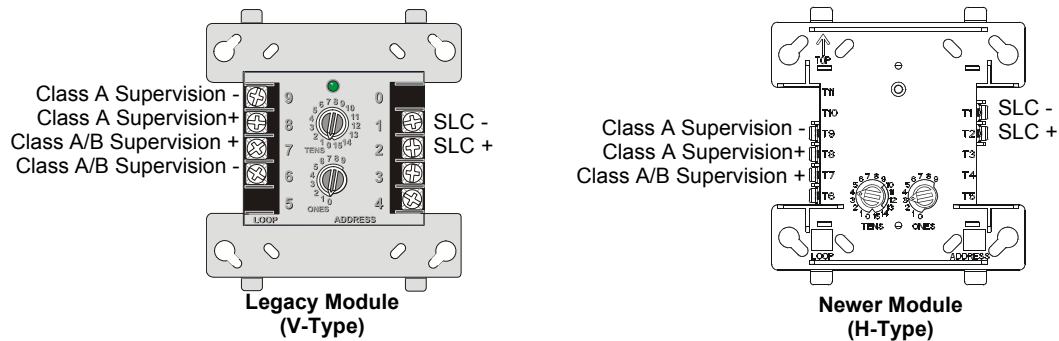

Legacy Module Terminal Number (V-Type)	Terminal Function	Newer Module Terminal Number (H-Type)
1	SLC -	1
2	SLC +	2
3	Unused	3
4	Unused	4
5	Unused	5
6	Class A/B Supervision -	6
7	Class A/B Supervision +	7
8	Class A Supervision +	8
9	Class A Supervision -	9
N/A	Unused	10
N/A	Unused	11

Table C.3 MMF-300 Terminal Conversions

C.4 MDF-300

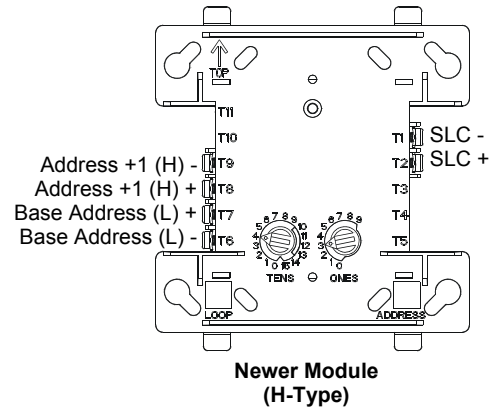
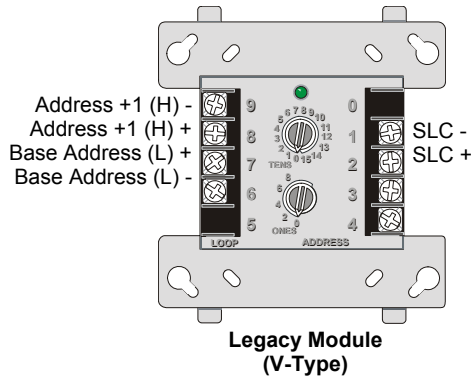

Legacy Module Terminal Number (V-Type)	Terminal Function	Newer Module Terminal Number (H-Type)
1	SLC -	1
2	SLC +	2
3	Unused	3
4	Unused	4
5	Unused	5
6	Base Address (L) -	6
7	Base Address (L) +	7
8	Address +1 (H) +	8
9	Address +1 (H) -	9
N/A	Unused	10
N/A	Unused	11

Table C.4 MDF-300 Terminal Conversions

Appendix D: Intelligent Detector Base Layouts for Legacy Devices

D.1 B350LP or B501 Detector Base

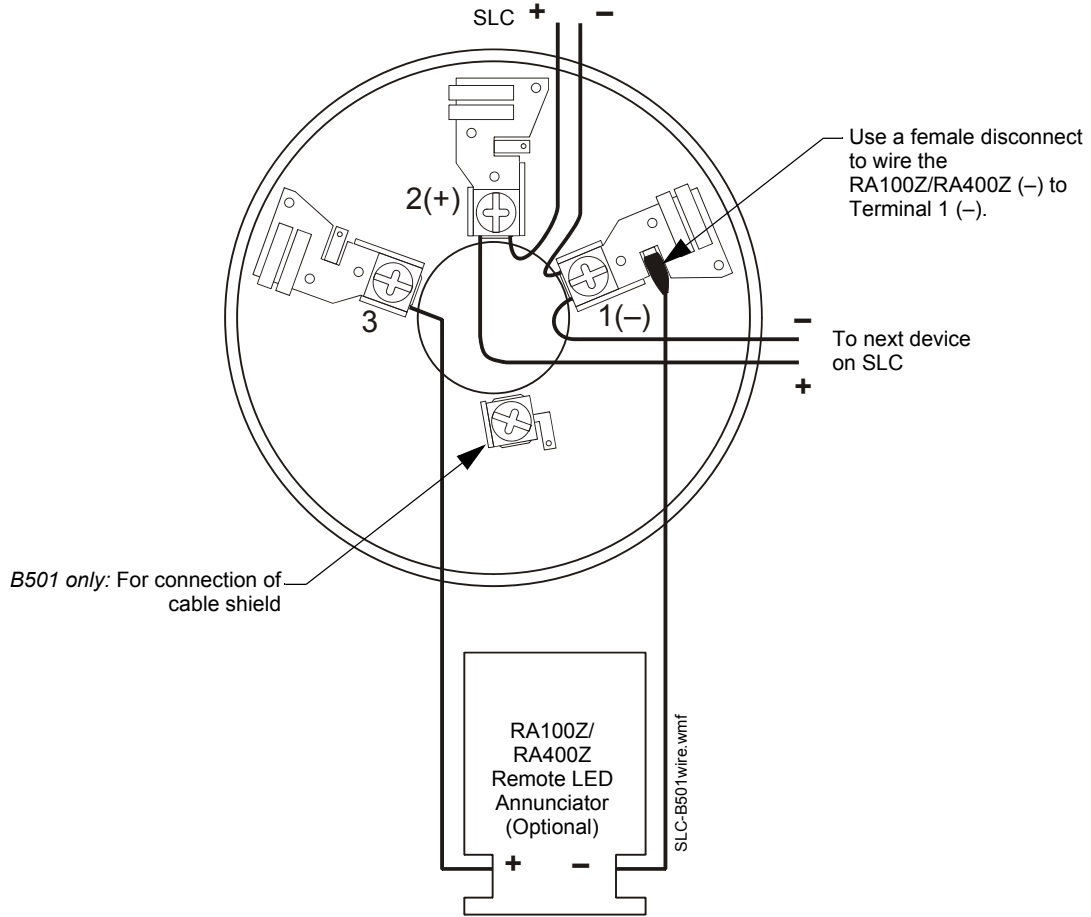

Figure D.1 Wiring the Legacy B350LP or B501 Detector Base



NOTE: The B350LP base wiring is identical to the B501, except there is no shield terminal.

D.2 B224BI Isolator Base

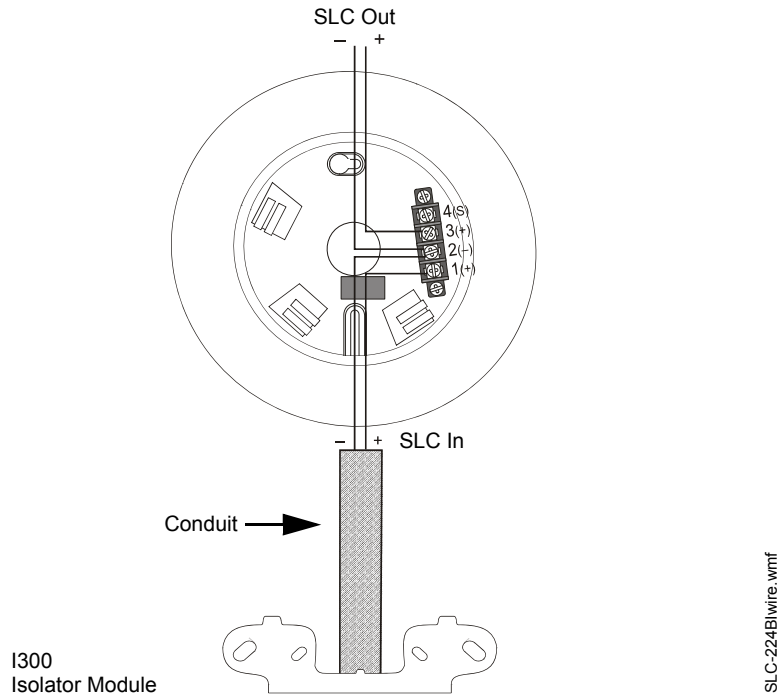

Figure D.2 Wiring the Legacy B224BI Isolator Base

D.3 B224RB Relay Base

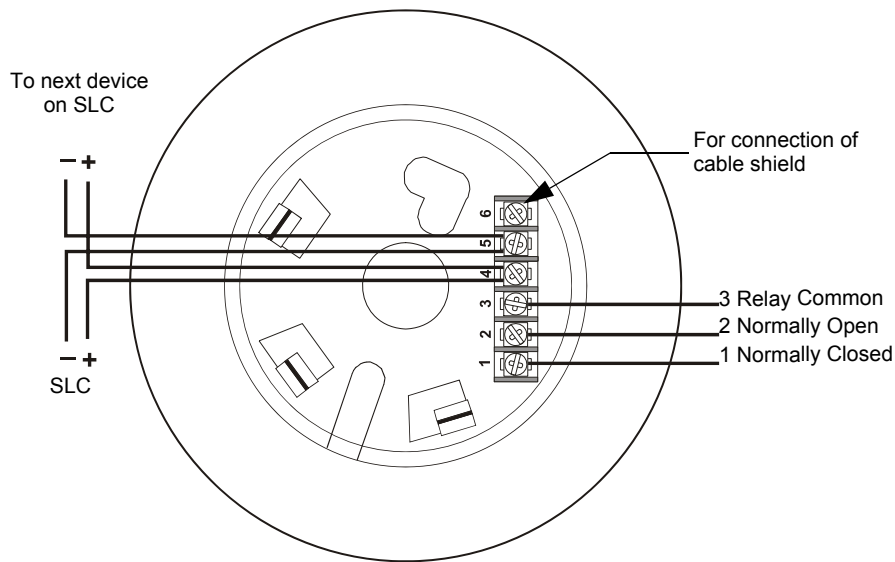
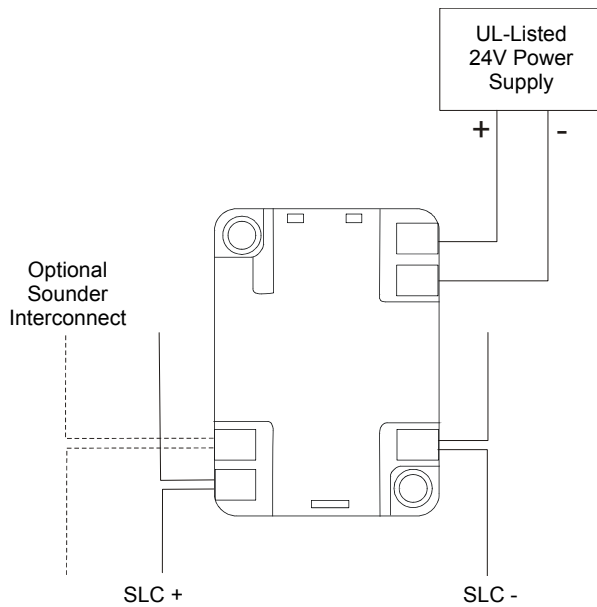

Figure D.3 Wiring the Legacy B224RB Relay Base

D.4 B501BH(-2) and B501BHT(-2) Sounder Bases



slc-b501bhwiring.wmf

Figure D.4 Wiring the Legacy B501BH(-2) and B501BHT(-2) Sounder Bases

Appendix E: Canadian Versions of SLC Devices

UL-listed SLC Device	ULC-listed SLC Device	Description
Detectors		
AD350, AD355, AD365, AD365-IV	AD350A, AD355A, AD365A, AD365A-IV	Intelligent detector that combines a photoelectric sensing chamber and fixed temperature heat detection (135°F/57.2°C).
CP350, CP355	CP350A, CP-355A	Addressable, intelligent smoke detector that incorporates an ionization sensing chamber. Designed to provide open area protection.
SD350, SD355, SD355R, SD365(-IV), SD365R(-IV)	SD350A, SD355A, SD355RA, SD365A(-IV), SD365RA(-IV)	Addressable intelligent smoke detector that uses a photoelectric sensing chamber. Listed for use in ducts. Designed to provide open area protection. (-IV in model number indicates ivory color.)
SD350T, SD355T, SD365T(-IV)	SD350TA, SD355TA, SD365TA(-IV)	Adds thermal sensors that will alarm at a fixed temperature of 135°F (57°C). (-IV in model number indicates ivory color.)
SD355CO, SD365CO	NA	Addressable detector that provides both fire and carbon monoxide (CO) detection.
H350, H355, H365(-IV)	H350A, H355A, H365A(-IV)	Intelligent thermistor sensing circuit for fast response. Designed to provide open area protection with 50 foot spacing capability. A fixed temperature sensor with 135°F fixed temperature alarm. (-IV in model number indicates ivory color.)
H350R, H355R, H365R(-IV)	H350RA, H355RA, H365RA(-IV)	Incorporates a thermal rate of rise of 15°F (9.4°C). (-IV in model number indicates ivory color.)
H355HT, H365HT(-IV)	H355HTA, H365HTA(-IV)	High temperature sensor with 190°F (87.8°C) fixed temperature alarm. (-IV in model number indicates ivory color.)
OSI-RI-FL	N/A	Addressable long range projected beam smoke detector designed to provide open area protection.
D355PL	D355PLA	An addressable non-relay photoelectric low flow smoke detector.
DNR	DNRA	Photoelectric Duct Detector, Low-flow. Requires SD350(A), SD355(A), or SD365(A) detector.
Bases		
B210LP	B210LPA	Standard U.S. Low-Profile base (6", 15.24 cm).
B501(-WHITE, -BL, -IV)	B501(-WHITE, -BL, -IV)	Standard European flangeless base (4", 10.16 cm) (-IV in model number indicates ivory color. -BL in model number indicates black color).
B501BH, B501BHT	B501BHA, B501BHTA	Sounder base, includes Sounder base with temporal sounder (UL 8th Edition).
B501BH-2, B501BHT-2	N/A	Sounder base, includes Sounder base with temporal sounder (UL 9th Edition).
B224RB, B224RB-WH, B224RB-IV	B224RBA, B224RBA-WH, B224RBA-IV	Low Profile Intelligent relay base.
B224BI, B224BI-WH, B224BI-IV	B224BIA, B224BIA-WH, B224BIA-IV	Low Profile Intelligent isolator base.
B200S-WH, B200S-IV	B200SA-WH, B200SA-IV	Intelligent sounder base, programmable, temporal or steady.
B200S-LF-WH, B200S-LF-IV	N/A	Intelligent sounder base, programmable, for low frequency applications
B200SR-WH, B200SR-IV	B200SRA-WH, B200SRA-IV	Intelligent sounder base, temporal or steady.
B200SR-LF-WH, B200SR-LF-IV	N/A	Intelligent sounder base for low frequency applications
B300-6(-IV)	B300A-6(-IV)	Standard U.S. Low-Profile base (6", 15.24 cm). (-IV in model number indicates ivory color.)
Monitor and Zone Interface Modules		
MMF-300	MMF-300A	Used for normally open contact alarm initiating devices, such as manual pull stations, four-wire smoke detectors, heat detectors, waterflow, and supervisory devices.
MMF-302	MMF-302A	Used to interface with two-wire smoke detectors in addition to normally open contacts.
MDF-300	MDF-300A	Two independent 2-wire Initiating Device Circuits (IDCs) at two separate, consecutive addresses. Wire supervised IDCs as NFPA Style B (Class B) or Style D (Class A) circuits. The modules come with a thermoplastic cover for mounting to a 4-inch (10.16 cm) square mounting box.
MMF-301	MMF-301A	Functionally similar to the MMF-300(A) Monitor Module, but offered in a smaller package for mounting directly in the electrical box of the device being monitored. (Class B input circuit only.)
BG-12LX	BG-12LX	An addressable manual pull station with key-lock reset feature. The addressable module is housed within the pull station.
Control Modules		
CMF-300	CMF-300A	Control Module, NAC: Addressable Control Module used as Notification Appliance Circuits (NACs) to power and supervise compatible, UL-listed notification appliances. Wired supervised NACs as NFPA Style Y (Class B) or Style Z (Class A). The modules come with a thermoplastic cover for mounting to a 4-inch (10.16 cm) square mounting box.
CRF-300	CRF-300A	Relay Control Module is similar to the CMF-300(A) except used as a Form-C control relay module.
Fault Isolator Module		

UL-listed SLC Device	ULC-listed SLC Device	Description
I300	I300A	The Fault Isolator Module protects the system against wire-to-wire short circuits on the SLC. It should be placed between groups of sensors in a Style 6 or Style 7 SLC to isolate short- and open-circuit problems and protect the rest of the loop so it can continue to operate normally. It is not addressable, but listed here due to its use in an SLC.
ISO-6	ISO-6A	The Six Fault Isolator Module protects the system against wire-to-wire short circuits on six isolated SLC circuits. Functionally the same as six I300(A) modules.
Multi-input/output modules		
MMF-300-10	MMF-300-10A	Supervises ten Class-B addressable Initiating Device Circuits (IDC) which monitor normally open contact initiating devices.
MMF-302-6	MMF-302-6A	Monitors six zones of conventional two-wire detectors.
CDRM-300	CDRM-300A	Dual Class B monitor / Form-C relay module.
CMF-300-6	CMF-300-6A	Similar in operation to the CMF-300, except it can activate six (6) Style Y (Class B) or three (3) Style Z (Class A) NACs.
CRF-300-6	CRF-300-6	Similar in operation to the CRF-300, except it provides six (6) Form-C relays.

Index

Numerics

- 24 VDC detectors **63**
- 24 VDC NAC power **44**
- 24 VDC power
 - MS-9200, MS-9600 **17**

A

- AD355 Detector **11, 54**
- AD365 Detector **11**
- address capacity **22**
- addressable
 - modules **10, 28**
- addressable devices **22**
- addressable modules (overview) **75**
- addressable monitor modules **28**
- alarm verification **54**
- analog intelligent devices **10**
- Authority Having Jurisdiction **13**
- auxiliary devices **11**

B

- B200SR Sounder Detector Base **54**
- B200SR-LF Sounder Detector Base for Low Frequency **54**
- B210LP **54**
- B224BI Isolator Detector Base **22, 54**
- B224RB Relay Detector Base **54**
- B300-6(-IV) **54**
- B350LP Detector Base **72**
- B501 Detector Base **54, 72**
- B501BH Sounder Detector Base **54**
- B501BH-2 Sounder Detector Base **54**
- B501BHT Temporal Sounder Detector Base **54**
- B501BHT-2 Temporal Sounder Detector Base **54**
- base **55, 56, 57**
- beam detector **12, 60**
- BEAM355 **12, 60**
- BEAM355S **12, 60**
- BG-12LX **12, 62**
- building entry/exit **65**

C

- CDRM-300 **53**
- CDRM-300 Multiple Input/Output Module
 - wiring **53**
- circuit fault **10**
- CLIP (Classic Loop Interface Protocol) **10, 12**
- close nipped conduit **27**
- CMF-300 Control Module **10, 44, 45**
 - installation **44**
 - wiring **44**
- CMF-300-6 Control Module **11, 44, 48, 49**
 - address disabling **46**
 - address setting **46**
 - circuit board **47**
 - installation **46**
 - short circuit protection **46**
 - Style selection **46**
 - wiring **48**

- common ground **65**
- communication protocol **10**
- conduit, close nipped **27**
- connectors, crimp-on **66, 67, 68**
- control modules **10**
 - overview **75**
- control panel **8**
- CP350 detector **11**
- CP355 Detector **54**
- CP355 detector **11**
- CRF-300 Relay Module **11, 50**
 - wiring **50**
- CRF-300-6 Relay Module **11, 50**
 - address disabling **52**
 - address setting **52**
 - circuit board **51**
 - wiring **52**

D

- D350P Detector **11**
- D350RP Detector **11**
- D355PL detector **11**
- DC resistance **14, 15**
- detector **54**
 - bases **54, 75**
 - beam **60**
 - heat **54**
 - ion **54**
 - multi-criteria **54**
- detector bases, wiring of **55**
- detectors
 - listing **11, 75**
- devices
 - addressable **22**
 - auxiliary **11**
 - maximum number between isolators **22**
 - supervised **64**
- DNR(W) Duct Detector Housing **12**
- document sources **8**
- drain wire **16**
- dry-contact **11**
- DTK-2LVLP-F **65**
- dual monitor module **32**

E

- electrical interference **14**
- emergency signaling circuit **36**
- End-of-Line Resistor **45, 48**

F

- fault **13, 26**
- fault condition **22**
- fault isolator modules **22**
- FCPS-24F **63**
- fire alarm service **32**
- foil **16**
- Form-C relay contacts **11, 50, 53, 54**
- four-wire configuration **45, 49**

G

- ground terminal **66, 67, 68**

H

- H350 Detector **11**
- H350R Detector **11**
- H355 Detector **11, 54**
- H355HT Detector **11**
- H355R Detector **11**
- H365 Detector **11**
- H365HT Detector **11**
- H365R Detector **11**
- heat detector **54**

I

- I300 Isolator Module **10, 22**
- initiating device circuits **28, 34, 37, 39**
- integral relay **22**
- ionization detector **54**
- ISO-6 Isolator Module **10, 22**
- isolator base **22**
- isolator base, wiring of **56**
- isolator module **10, 22, 26, 27**
 - how it works **22**
 - wiring of **22**

K

- key-lock reset **62**

L

- LEDs **54**
- local building code **65**
- loop resistance **14, 15**
- loops **16**

M

- MDF-300 Dual Monitor Module **10, 32, 39**
 - wiring **39**
- metal conduit **16, 26**
- mini monitor module **32**
- minimum resistance **63**
- MMF-300 Monitor Module **10, 28, 34, 35, 36**
 - wiring **34**
- MMF-300-10 Monitor Module **10, 29, 37, 38**
 - wiring **37**
- MMF-301 Mini Monitor Module **10, 32**
- MMF-302 Zone Interface Module **10, 30, 40, 41**
 - wiring **40**
- MMF-302-6 Interface Module **10, 31, 42, 43**
 - wiring **42**
- module circuits **28**
- modules
 - addressable **10**
 - control **10**
 - isolator **10**
 - monitor **10**
 - relay **11**
 - zone interface **30**
- monitor modules **10, 28**

- overview 75
 - multi-criteria detector 54
 - multiple input/output module 53
 - multi-point module 33
- N**
- NAC 10
 - NAC power 44, 64
 - NAC wiring 44
 - NEC Article 800 65
 - NFPA Style 4
 - wiring of 20
 - with I300 24, 25
 - NFPA Style 6
 - wiring of 21
 - with I300 26
 - NFPA Style 7 22
 - with isolator modules 27
 - NFPA Style B
 - IDC wiring 34, 37, 39, 40, 42
 - NFPA Style D
 - IDC wiring 35, 38, 41, 43
 - NFPA Style Y 44
 - wiring of 44, 48
 - NFPA Style Z 44
 - wiring of 45, 49
 - non-resettable power 17
 - normally closed contacts 64
 - notification appliance circuit 10
- O**
- older version and newer version modules 8
 - OSI-RI-FL beam detector 12, 60
- P**
- performance 12
 - photoelectric 54
 - PLP-42N 65
 - polling protocols 10
 - power run 63, 64
 - power supervision relay 45, 48, 49, 64
 - power supplies 63
 - proper gauge wire 63
 - pull station 12, 27
 - wiring of 62
- R**
- RA100Z 55
 - RA400Z 55
 - rate of rise 11
 - ratings, relay contact 44, 50, 53
 - relay base 22
 - wiring of 56
 - relay contact ratings 44, 50, 53
 - relay module 11
 - relays
 - Form-C 11
 - remote LED annunciator 55
 - resettable power 17
 - resistance 14, 15
- rotary switches 33, 38, 39, 40, 41, 42, 43, 54
- S**
- SD350 Detector 11
 - SD350T Detector 11
 - SD355 Detector 11, 54
 - SD355CO Detector 11
 - SD355R Detector 11
 - SD355T Detector 11
 - SD365 Detector 11
 - SD365CO Detector 11
 - SD365R Detector 11
 - SD365T Detector 11
 - sensing circuit, thermistor 11
 - short circuit 22
 - signaling line circuit 10
 - single point module 33
 - SLC address, setting of 33, 54
 - SLC connections 17
 - SLC terminal block 16
 - SLC wiring 34, 35, 36, 37, 38, 39, 40, 41, 42, 43
 - SLCP-30 65
 - smoke detectors 54
 - sounder base 22
 - sounder base, wiring of 57
 - sprinkler supervision 32
 - supervised
 - circuit 64
 - devices 64
 - supplying power 63
 - suppressors, surge 65
 - surge protector 10, 13, 65
 - switching 44
- T**
- terminal blocks 17
 - termination of shield 16
 - thermal detector 54
 - thermistor sensing circuit 11
 - trouble conditions 13, 22
 - T-tapping 14, 20, 21, 26, 27
 - twisted-pair shielded wiring 14
 - two-wire configuration 44, 48
 - two-wire detectors 64
- U**
- unregulated power 17
- V**
- verification cycle 54
- W**
- waterflow alarm service, automatic and manual 32
 - W-GATE 12, 57
 - external power 59
 - SLC connections 58
 - SLC power 58
 - wire length 15, 16
 - wire size 14
- wireless gateway 12, 57
 - external power 59
 - SLC connections 58
 - SLC power 58
 - wiring
 - I300 22
 - ISO-6 23
 - MDF-300 39
 - MMF-300 34
 - MMF-300-10 37
 - MMF-302 40
 - MMF-302-6 42
 - NACs 44
 - wiring pair 65
 - wiring requirements 14
 - wiring style requirements 13
- Z**
- zone interface module 30

Manufacturer Warranties and Limitation of Liability

Manufacturer Warranties. Subject to the limitations set forth herein, Manufacturer warrants that the Products manufactured by it in its Northford, Connecticut facility and sold by it to its authorized Distributors shall be free, under normal use and service, from defects in material and workmanship for a period of thirty six months (36) months from the date of manufacture (effective Jan. 1, 2009). The Products manufactured and sold by Manufacturer are date stamped at the time of production. Manufacturer does not warrant Products that are not manufactured by it in its Northford, Connecticut facility but assigns to its Distributor, to the extent possible, any warranty offered by the manufacturer of such product. This warranty shall be void if a Product is altered, serviced or repaired by anyone other than Manufacturer or its authorized Distributors. This warranty shall also be void if there is a failure to maintain the Products and the systems in which they operate in proper working conditions.

MANUFACTURER MAKES NO FURTHER WARRANTIES, AND DISCLAIMS ANY AND ALL OTHER WARRANTIES, EITHER EXPRESSED OR IMPLIED, WITH RESPECT TO THE PRODUCTS, TRADEMARKS, PROGRAMS AND SERVICES RENDERED BY MANUFACTURER INCLUDING WITHOUT LIMITATION, INFRINGEMENT, TITLE, MERCHANTABILITY, OR FITNESS FOR ANY PARTICULAR PURPOSE. MANUFACTURER SHALL NOT BE LIABLE FOR ANY PERSONAL INJURY OR DEATH WHICH MAY ARISE IN THE COURSE OF, OR AS A RESULT OF, PERSONAL, COMMERCIAL OR INDUSTRIAL USES OF ITS PRODUCTS.

This document constitutes the only warranty made by Manufacturer with respect to its products and replaces all previous warranties and is the only warranty made by Manufacturer. No increase or alteration, written or verbal, of the obligation of this warranty is authorized. Manufacturer does not represent that its products will prevent any loss by fire or otherwise.

Warranty Claims. Manufacturer shall replace or repair, at Manufacturer's discretion, each part returned by its authorized Distributor and acknowledged by Manufacturer to be defective, provided that such part shall have been returned to Manufacturer with all charges prepaid and the authorized Distributor has completed Manufacturer's Return Material Authorization form. The replacement part shall come from Manufacturer's stock and may be new or refurbished. THE FOREGOING IS DISTRIBUTOR'S SOLE AND EXCLUSIVE REMEDY IN THE EVENT OF A WARRANTY CLAIM.

Warn-HL-08-2009.fm

ISO 9001
CERTIFIED
ENGINEERING & MANUFACTURING
QUALITY SYSTEMS

One Fire-Lite Place, Northford, CT 06472-1601 USA
USA - Phone: (203) 484-7161
Canada - Phone: (905) 856-8733
www.firelite.com

 **FIRE-LITE ALARMS**
by Honeywell