



DOBOT CR Collaborative Robot Series

SAFE, FLEXIBLE
AND SELF-LEARNING



ABOUT DOBOT

DOBOT is the world leading provider of smart robotic arm solutions. Our solution seamlessly integrates AI-powered lightweight robotic arms and proprietary software suite, effectively helping industrial clients navigate around rising wages, lack of qualified laborers and other bottlenecks preventing companies to scale. By replacing traditional manufacturing processes with advanced human-machine collaboration models, DOBOT meets the demands of flexible production, plays a critical role in elevating China manufacturing industry and will be the standard of tomorrow's smart production process.

In addition, DOBOT is proud to be spearheading robotic arm awareness in education and research. We have partnered with globally renowned K-12 and higher academic institutions, providing DOBOT robot solutions to over 1 million educators and researchers.

DOBOT is customer centric and values independent innovation. In the past 5 years since founding, we insist on developing our own solution on key technologies. Our team is always one step ahead, creating new product categories and defining new smart production standards to support the manufacturing industry.

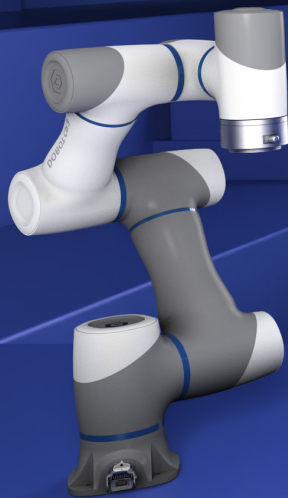

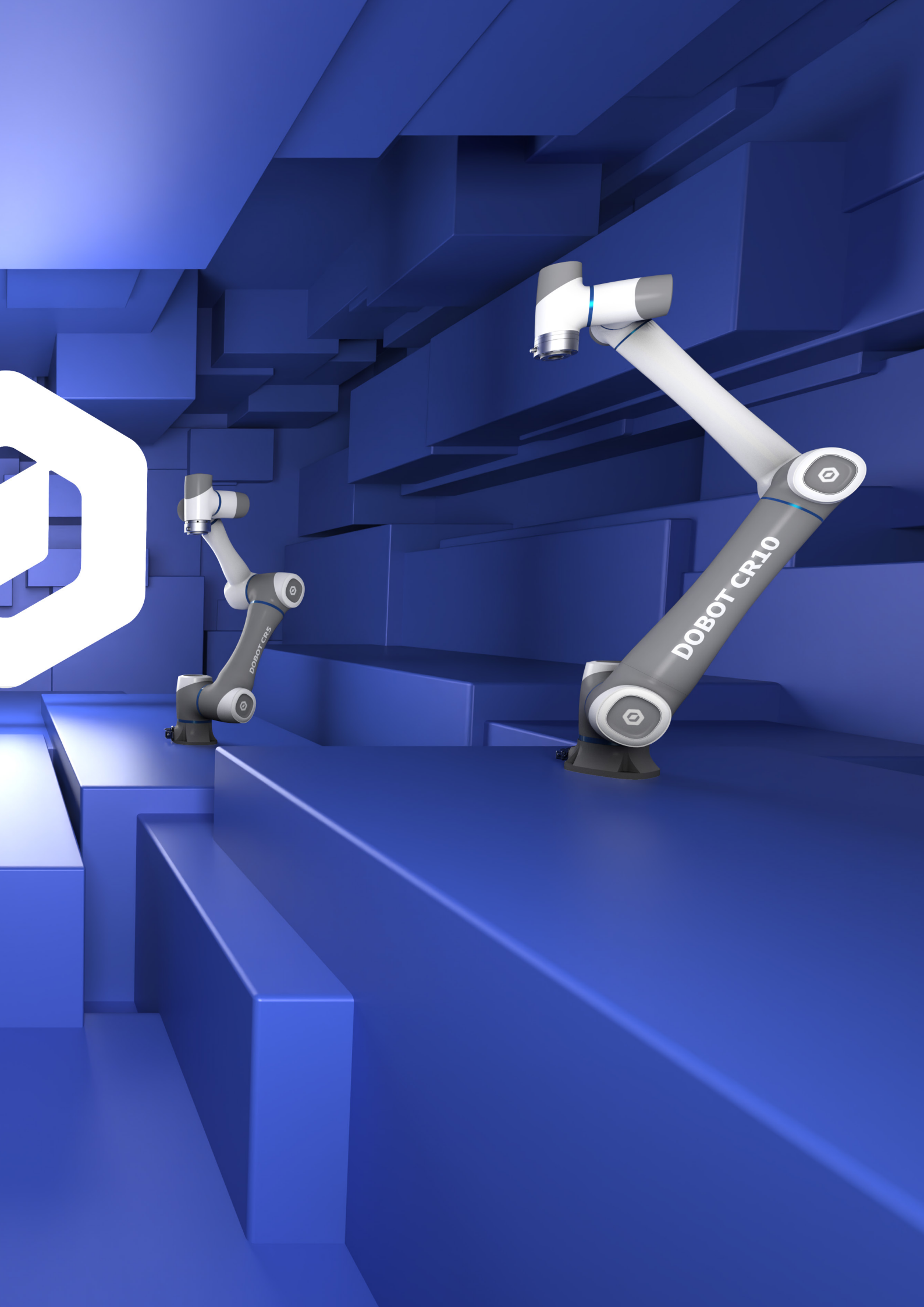

SAFE, FLEXIBLE AND SELF-LEARNING





DOBOT CR Collaborative Robot Series features 4 cobots with payloads of 3kg, 5kg, 10kg, and 16kg. These cobots are safe to work alongside, cost-effective and adaptable to a variety of application scenarios. CR Cobots offer flexible deployment, single-hand guidance, collision monitoring, trajectory reproduction and other functions, making it even more suitable for man-robot collaboration scenarios.

Easy to Use

- Easy programming using visual, drag & drop and block-based programming language
- Teachable by demonstration or single-hand guidance
- Real-time control on your mobile phone, iPad, or tablet through Wi-Fi connection

Inherently Safe Collision-Free Collaborative

- Real-time obstacle avoidance with every-5ms dynamic monitoring, 10cm-proximity pre-touch sensing & online route planning combined to produce the best trajectory to avoid obstacles
- Multi protections with force sensing, obstacle avoidance & camera entry detection

Flexible & Fast Deployment

- Fast setup requiring only 20 minutes to set up, 1 hour to put into application
- Wide compatibility with mainstream end-effectors and accessories
- Fast changeovers perfect for customized/flexible/lean manufacturing

Economical & Durable

- Limited space with no security fence required
- Long-lasting durability with 32,000 hours of service life, built-in energy feedback & hectowatt-level power consumption

Flexible Deployment, One Step Ahead

- Out-of-box experience
- Compact design, simple wiring
- Flexible deployment and time-saver

step 1



step 2



step 3



step 4



Multiple Control Methods

- Low latency & high noise immunity
- Support controls on Android, iOS and Windows
- high-performance network card with transmission up to 433Mbps





Easy to Teach and Control





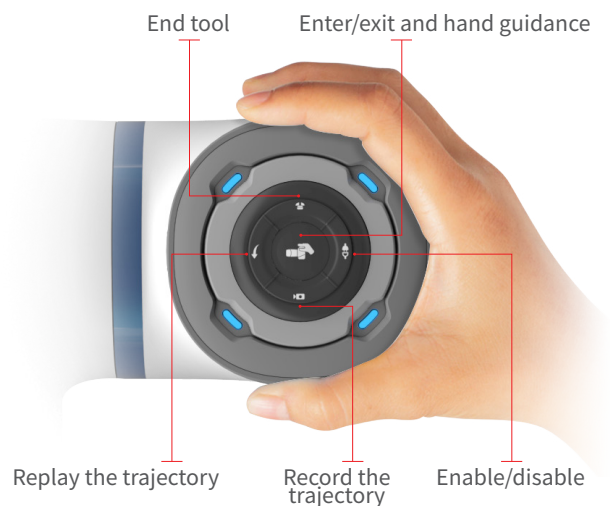











DOBOT cobots feature an Intelligent Interactive Panel that is embedded with LEDs, indicating the status of the robot.







One touch of the button enables you to drag and move the robot to teach it a specific path, and freely control the gripper, suction cup and other end tools.



Wide Compatibility

- Wide compatibility with a wide array of peripheral components
- Suitable for feeding, assembly, inspection, handling, screwdriving, sanding, and gluing
- Multiple I/O and communication interfaces unlock unlimited expansion possibilities
- The addition of software/API constitutes a DOBOT open platform where a greater collection of accessories are compatible

 Robotiq Gripper	 Schunk Gripper	 Onrobot Gripper	 SINAUN Gripper
 HD-Robotics Gripper	 Rochu Gripper	 HITOBOT Gripper	 SRT Gripper
 Robotiq Sensor	 Onrobot Sensor	 LINKTOUCH Sensor	 ATI Sensor
 COGENEX Vision	 MICROSCAN Vision	 Hikvision Vision	 Hikvision Vision

 Automobile	 3C	 Chemical	 Medical	 Semiconductor	 Retail
Feeding	Feeding	Feeding	Extracting liquid	Feeding	Pick & Place
Spraying	Welding	Handling	Mixing liquid	Photoetching	Sorting
Assembly	Assembly	Labeling	Moving liquid	Cleaning	Handling
Inspection	Gluing	Measuring	Bone cutting	Sculpting	Packaging
Screwdriving	Handling	Testing	Bone cutting	Sedimentation	Making latte art
Pick & Place	Palletizing	Machine Tending	Puncturing	Machine Tending	Baking

SDK Further Development

- Provide a wealth of application packages, including SDK development packages, helping you quickly implement industrial and commercial application scenarios.
- Supplemented by the corresponding software API, DOBOT cobot constitutes the open platform where most accessories in the system are supported.
- Plug and play meet the needs of flexible manufacturing in multiple scenarios.

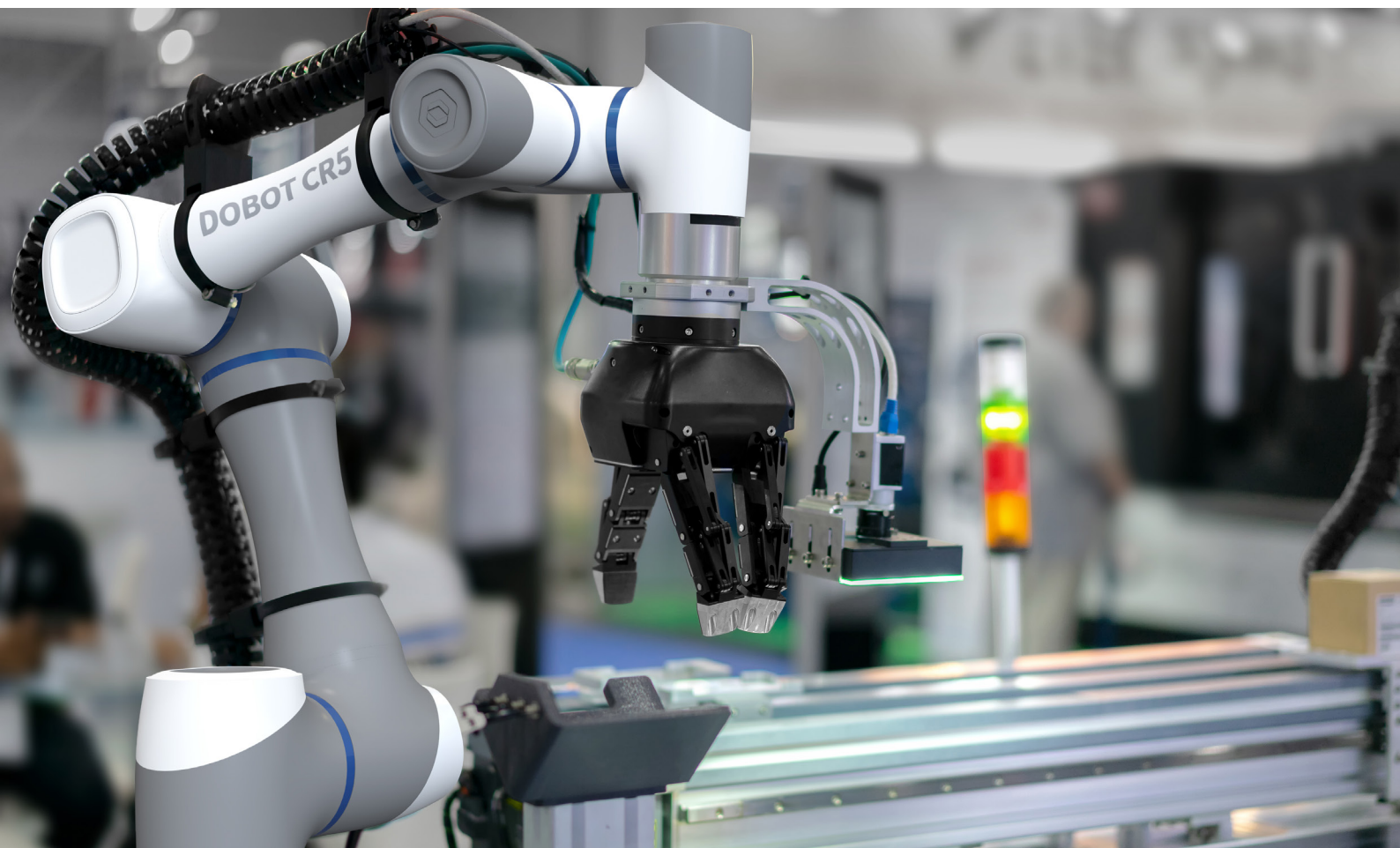
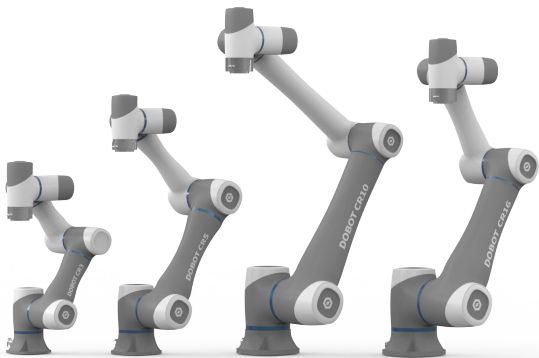

Dobot SafeSkin - Inherently Safe, Collision-Free Collaborative

Dobot SafeSkin is a wearable collision detection product for collaborative robots tailored by DOBOT. Dobot SafeSkin can cover large areas, sense objects in the distance, respond fast and withstand interference. Different from the traditional collision detection solution for cobots, Dobot SafeSkin uses the Middle Section Collision Detection Technology to ensure high efficiency while providing cobots with non-contact proximity sensing, collision prevention and other human-machine collaboration safety solutions.

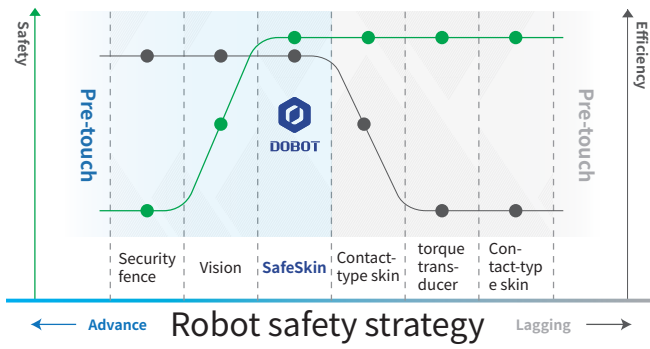

Safety function

Dobot SafeSkin can perceive the intrusion within 15cm, then judge and respond to it in 10ms. Less than 0.1s emergency stop time facilitates high-efficiency collision protection. After the intruder leaves, the robot automatically resumes operation without compromising production efficiency.



Control Software for CR Cobot Series

DOBOT SCStudio

SCStudio, the windows control software for CR cobots, supports user-friendly interface programming and further development. It also provides a multitude of kinematic algorithms for mechanical structures, and has a built-in virtual simulation environment for quicker development of various application scenarios.

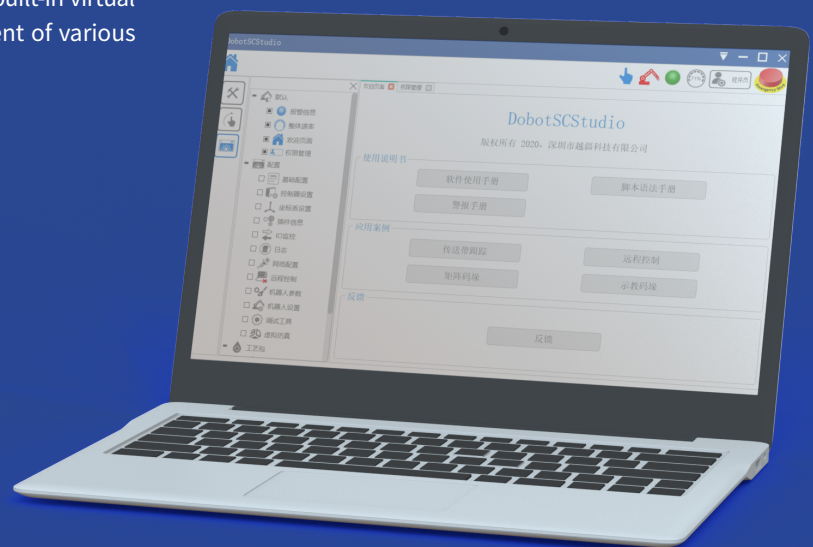

CRStudio

CRStudio, the mobile control software for tablets, supports graphical programming and is intuitive and easy to understand even for users without much programming experience. For advanced users, the platform also provides script programming. Multiple programming methods are offered for you to choose from.





Auto Manufacturing

Automobile manufacturing is one of the most automated industries in manufacturing. Among its four major processes, stamping, welding, and painting have basically been automated with industrial robots in place of workers and technical engineers who control the robots. Due to the complexity and flexibility, the assembly process is not applicable for traditional robots. Collaborative robots work alongside operators, improving the whole factory's efficiency.

Solution to Pain Points

1. More Flexibility

Unlike traditional industrial robots, cobots are more flexible in deployment.

2. Reliability

Repeatability is up to 0.02mm, meeting the installment of high-quality motors.

3. Fewer Requirements for Working Environment

Immune from the noise and strong lights resulting from welding at the workplace

4. Lower labor costs

Amid rising labor costs, cobots are effective in keeping down the factory's costs.

Applications

Feeding

Spraying

Assembly

Inspection

Screwdriving

Pick and Place



DOBOT Cobots can be useful in automating scenarios of automobile and relevant components including dip-coating, spraying, feeding, screwdriving, pick and place and machine tending.



3C

“Computers, Communications, and Consumer Electronics” make up what's commonly referred to as the 3C industry in China. Manufacturing of 3C industry features large quantity, frequent updates massive labor involved and highly repetitive tasks.

Solution to Pain Points

1. Flexibility

Adaptable to a variety of small bulk production lines.

2. Consistency

Deliver consistent assembled products, allowing for better quality control.

3. Efficiency

Compared with human counterparts, robots have quick take time, higher efficiency and create more value.

4. Reliable

Cobots produce more reliable performance than people and thus better quality products.

Applications

Feeding

Welding

Assembly

Gluing

Handling

Palletizing

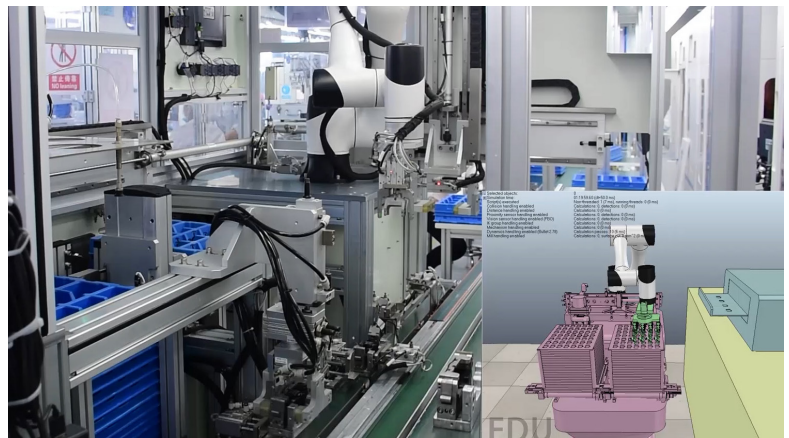

DOBOT CR cobots, integrated with force torque and DOBOT SafeSkin, can easily handle assembly, feeding (on plasma cleaning machine indicated in the image above), among other tasks.



Chemical

In the era when manufacturing is more getting flexible and intelligent, IoT technologies are impetrating our lives. Bar code as a carrier of recognizing things has been widely applied in logistics management system in chemical industry. Over the years, more and more businesses turn to robots replacing employees to do labelling for better efficiency.

Solution to Pain Points

1. Less Demanding to Working Environment

Adaptable to a variety of work conditions including those with high heat, toxic gases and radiation.

2. Wider Applications

Applicable to all kinds of labelling of plastics products.

3. High Accuracy and Fewer Errors

Able to label accurately and efficiently, avoiding mistakes and mixing materials.

4. Convenient & Easy to Use

The robots can be taught through simple single hand guidance and interactive programming.

Applications

Feeding

Handling

Labeling

Measuring

Testing

Palletizing



DOBOT Cobot Packaging in Chemical Industry

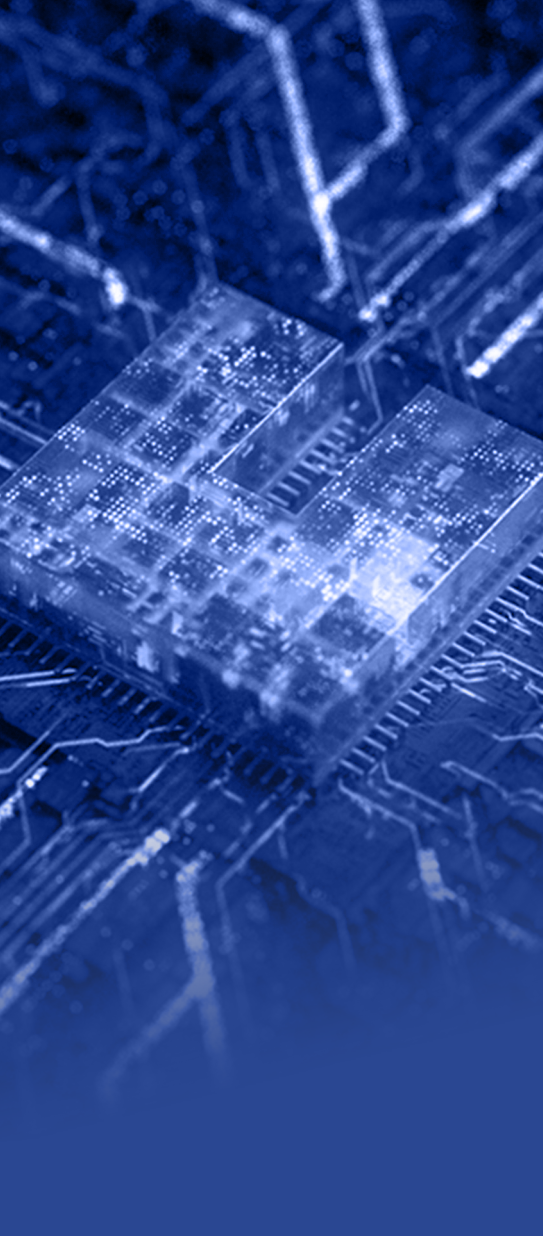

Semiconductors

Among the global semiconductor value chain links, manufacturing accounts for 46%, the most valuable and the central link of the semiconductor industry. It can drive the development of the entire industry and has an irreplaceable role.

Solution to Pain Points

1. Flexibility

Adaptable to a variety of small bulk semiconductor production patterns, saving frequent changeovers and time.

2. Efficiency & Reliability

Applicable to all kinds of labelling of plastics products.

3. High Accuracy and Less Errors

High speed and efficient product is a perfect fit for short-run, high efficiency and fast-paced semi conductor manufacturing.

4. Convenient & Easy to Use

The robots can be taught through simple single hand guidance and interactive programming.

Applications

Feeding

Photoetching

Cleaning

Sculpting

Sculpting

Machine Tending

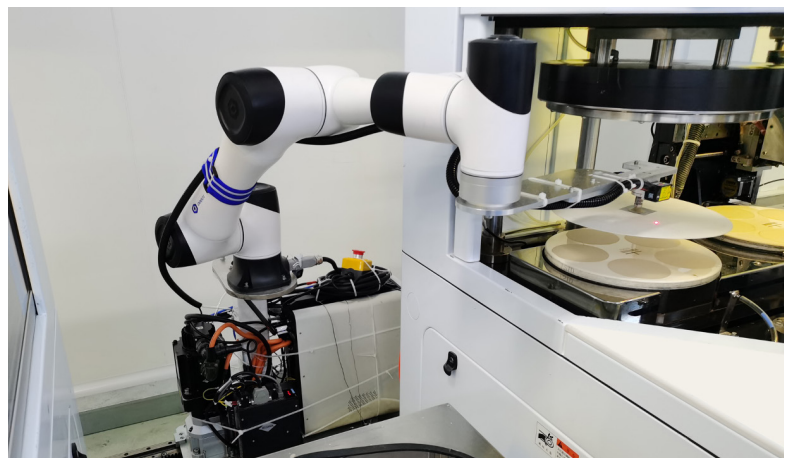

DOBOT Cobot in Semiconductor Industry

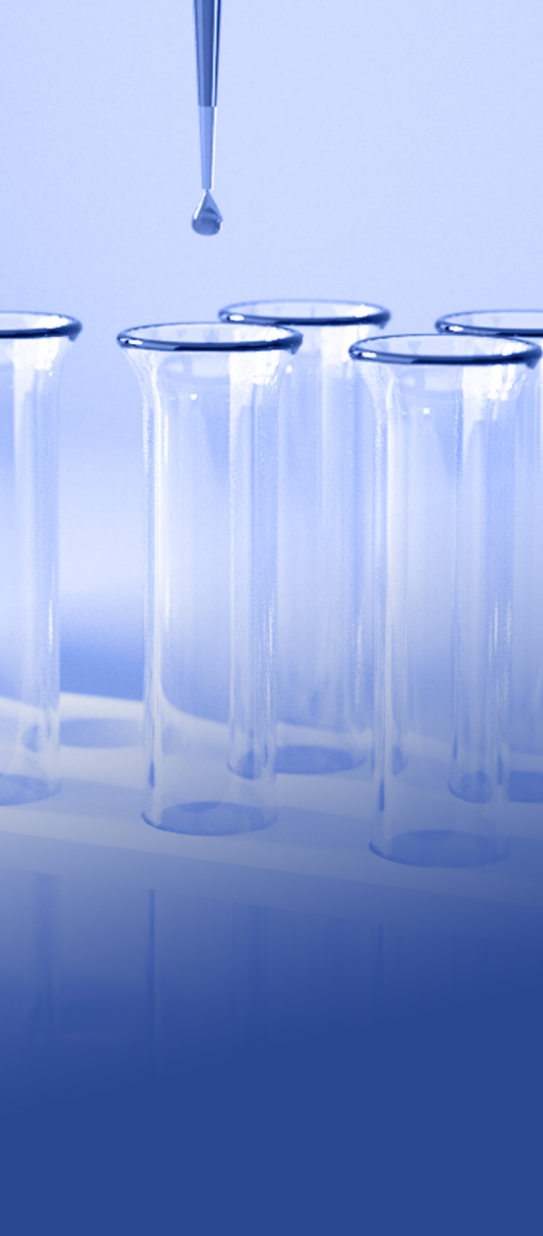

Medical

As one of the most notable areas, medical professionals are often prone to long hours, high intensity work tendency and special environment. Turning to robots can address these problems. Medical robots are easy to use, highly and adaptable, which can assist and expand the work of doctors ability.

Solution to Pain Points

1. Safe

Combined with force torques, DOBOT cobots are very safe to work alongside, helping you complete different procedures in various environments.

2. Versatile

Dobot cobots can be combined with different types of flexible grippers, greatly enhancing the scope of robotic work.

3 Convenient & Easy to Use

The robots can be taught through simple single hand guidance and interactive programming.

Applications

Extracting liquid

Mixing liquid

Moving liquid

Bone cutting

Biopsy

Puncturing



DOBOT Cobots in Medical Industry



Applications

Pick & Place

Sorting

Handling

Packaging

Making latte art

Baking

Retail

The emergence of unmanned retail stores and smart vending cabinets has allowed robots to gradually enter people's daily lives. It brings disruption to how brick-and mortar stores operate by further improving efficiency and reducing costs.

Solution to Pain Points

1. Convenient & Fast

Customers only need to place an order online or through a mobile app, and the robot can immediately take out or make the customer purchased order.

2. Save Costs

The use of robots can save a lot of labor costs, and can operate 24/7, improving time utilization.

3. A Powerful Customer Magnet

With an intelligent robot system in place, the restaurant or shop will attract a lot of curious customers. The sort of content will be Instagram-worthy and great for publicity.



DOBOT Cobots in Retail

CR3

Industries

- Food & Chemical
- Furniture & Appliances
- Metal Processing
- Auto Components

Applications

- Product Line Tracking in 3C industry
- Dynamic Screwdriving
- Assembly
- Feeding

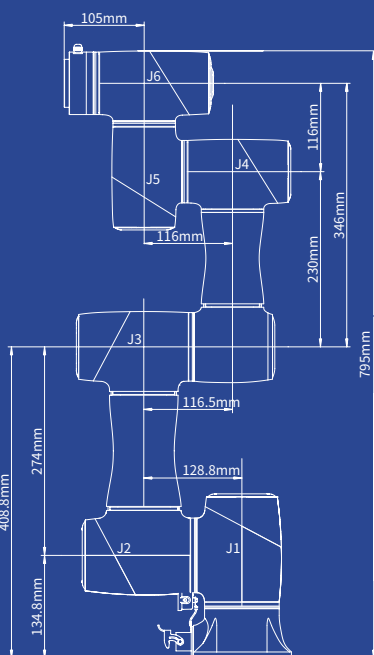
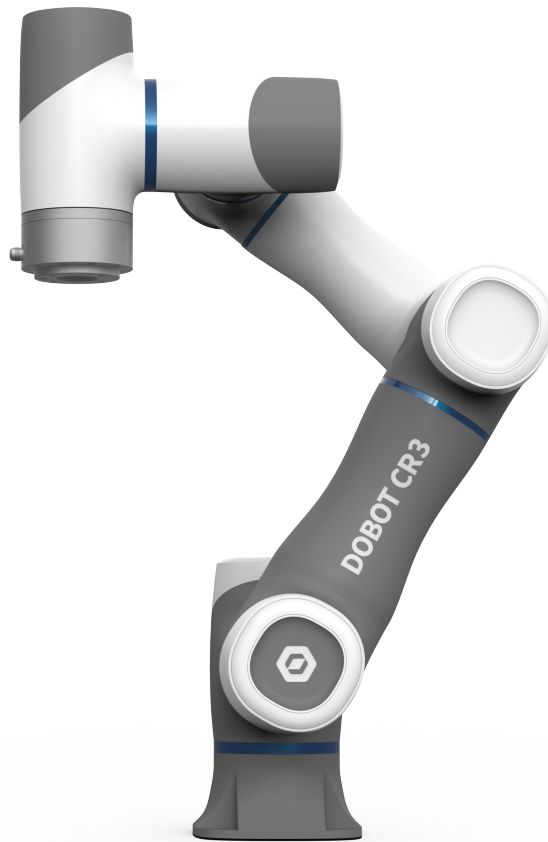

Working Range

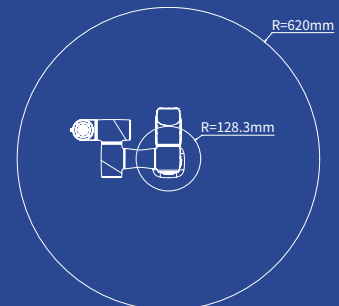
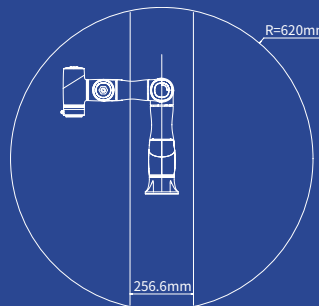

CR5

Industries

- 3C Automation
- Food Packaging
- Furniture & Appliances
- Metal Processing
- Auto Components

Applications

- Product Line Tracking in 3C industry
- Dynamic Screwdriving
- Assembly
- Material Processing (Polishing & Sanding)

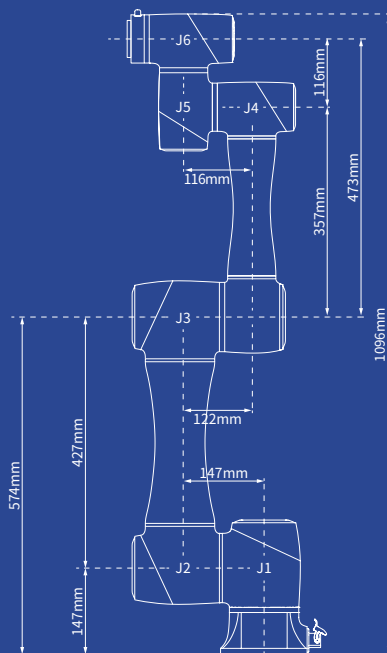

Working Range

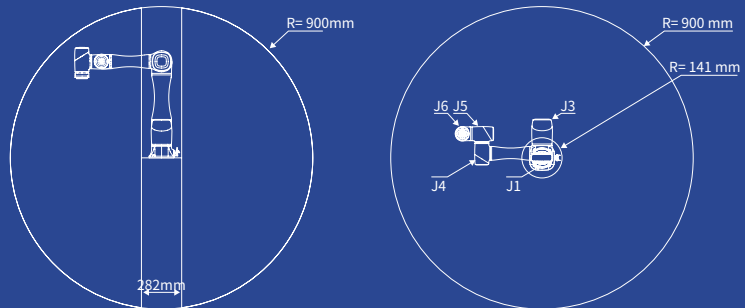

CR10

Industries

Food & Chemical

Furniture & Appliances

Metal Processing

Auto Components

Applications

Machine Tool Loading/Unloading

Heavy Duty Pick and Place

Depalletizing & Palletizing

Material Processing (Polishing & Sanding)

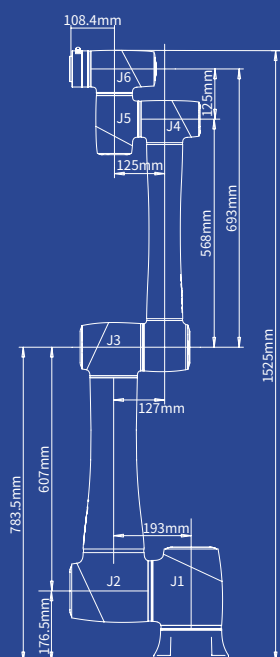

Working Range

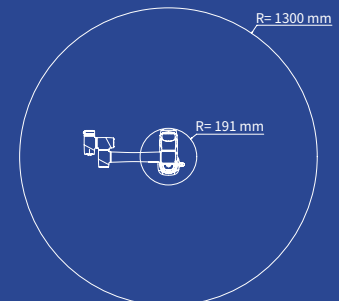
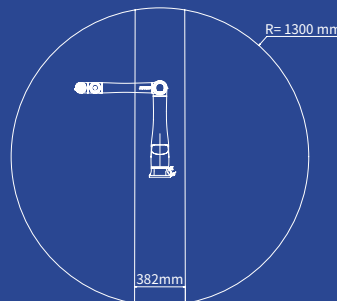

CR16

Industries

- Medical & Chemical
- Furniture & Appliances
- Metal Processing
- Auto Manufacturing

Applications



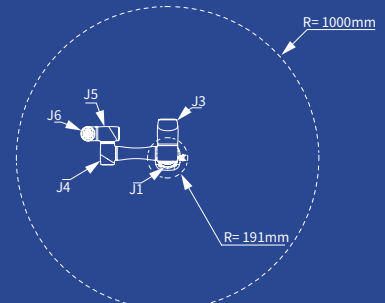
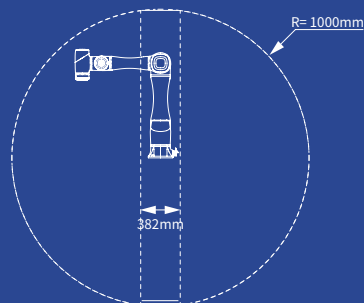
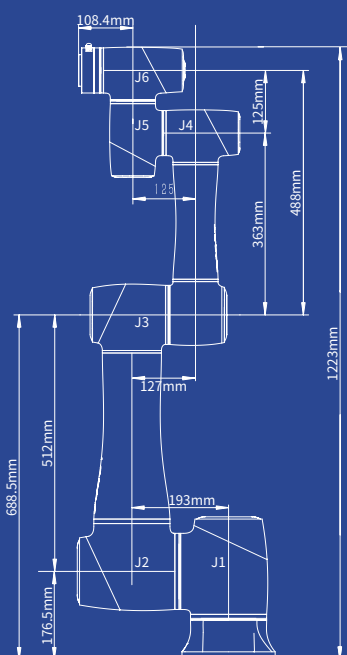

- Machine Tool Loading/Unloading
- Heavy Duty Pick and Place
- Depalletizing & Palletizing
- Material Processing (Polishing & Sanding)



Working Range

CR Collaborative Robot Series

Specifications

Model		 CR3	 CR5	 CR10	 CR16
Weight		16.5kg	25kg	40kg	40kg
Rated Payload		3kg	5kg	10kg	16kg
Reach		620mm	900mm	1300mm	1000mm
Max. Reach		795mm	1096mm	1525mm	1223mm
Rated Voltage		DC48V	DC48V	DC48V	DC48V
Max. Speed of TCP		2m/s	3m/s	4m/s	3m/s
Joint Ranges	J1	±360°	±360°	±360°	±360°
	J2	±360°	±360°	±360°	±360°
	J3	±155°	±160°	±160°	±160°
	J4	±360°	±360°	±360°	±360°
	J5	±360°	±360°	±360°	±360°
	J6	±360°	±360°	±360°	±360°
Max. Speed of Joints	J1/J2	180° /s	180° /s	120° /s	120° /s
	J3/J4/J5/J6	180° /s	180° /s	180° /s	180° /s
End-Effector I/O Interface	DI/DO/AI	2			
	AO	0			
Communication Interface	Communication	RS485			
Controller I/O	DI	16			
	DO/DI	16			
	AI/AO	2			
	ABZ Incremental Encoder	1			
Repeatability		±0.02mm	±0.02mm	±0.03mm	±0.03mm
Communication		TCP/IP, Modbus, EtherCAT, WIFI			
IP Rating		IP54			
Temperature		0°C~ 45°C			
Power Consumption		120W	150W	350W	350W
Materials		Aluminum alloy, ABS plastic			

Controller Specifications



CC16X

Model	
Size	360mm(Length)*160mm(Width)* 402.4mm(Height)
Weight	12kg
Controlled Axes	6 Axes + External Expansion Axes
Power Input	Single Phase 110V/220V AC, 7.5A, 50/60HZ
Power Output	48V,20A
Supported Motor Power (Max)	-
Braking Resistors	Four, 17W, 10Ω
Supported Types of Encoders	-
Communication Interface	EtherCAT(for External Axes),Ethernet
I/O Interface	16 Digital Outputs
	16 Digital Inputs/Outputs (Multiplexing)
	2 Analog Outputs (Voltage: 0V-10V, Current: 4mA-20mA)
	2 Analog Inputs (Voltage: 0V-10V, Current: 4mA-20mA)
	1 Incremental Encoder ABZ Input
Method of Teach & Playback	Hand-Held Teach Pendant/APP
Programming Language	Script
	Graphical Programming(Blockly)
Installment	Floor
Environment	Temperature: 0°C ~45°C ,Humidity: ≤95%,No Condensation
Protection Rating	IP20
Cooling Method	Forced-Air Cooling
Safety Features	Emergency stop function, reserved external security interface that can be controlled by I/O interface
Indicator	The indicator light will be steady red when the power is on; the indicator light will be off when the power is off.
Maintenance	Diagnostic Software Tool
	Power-off Zero Save
	Reserve Remote Service

GLOBAL SERVICE & SUPPORT

With years of rapid development, Dobot has extended its service to more than 100 countries and regions around the world.







Technical Support

DOBOT provides step-by-step training to help our customers better understand and use DOBOT robots. The training includes but is not limited to equipment installation, robot expansion, upgrade and transformation, remote technical support, and so on.

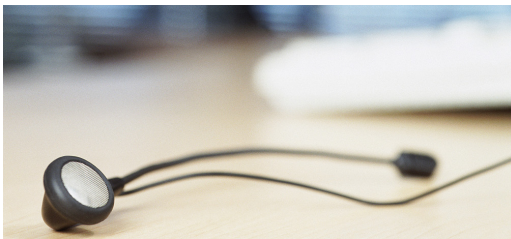

After-Sales Service

DOBOT offers timely and professional service, including online support via phone or emails.



Request a Quote?

Contact sales@dobot.cc

Call +(86) 400 800 7266 to find a distributor near your location



Any Questions?

Contact info@dobot.cc

SHENZHEN YUEJIANG TECHNOLOGY CO., LTD. (DOBOT)

Phone: +86-0755-33100907

Email: info@dobot.cc

Address: 9-10 Floors, Building No.2, Chongwen Garden, Nanshan iPark,
Liuxian Blvd, Nanshan District, Shenzhen, China





www.dobot.cc