

Spatial Reality Display

取扱説明書 _____ JP

Operating Instructions _____ GB

Mode d'emploi _____ FR

お買い上げいただきありがとうございます。

 **警告** 電気製品は安全のための注意事項を守らないと、
火災や人身事故になることがあります。

この「取扱説明書」には、事故を防ぐための重要な注意事項と製品の取り扱いかたを示してあります。
この「取扱説明書」をよくお読みのうえ、製品を安全にお使いください。お読みになったあとは、
いつでも見られるところに必ず保管してください。

ELF-SR1

Table of Contents

Precaution	7
On Safety	7
On Installation	7
Connecting to Other Devices	7
Handling the Screen	7
On a Long Period of Use	7
On Dew Condensation	8
On Watching 3D Video Images	8
Handling and Maintenance of the Screen	8
On Transportation of the Unit	8
Disposal of the Unit	9
On the Viewing Environment	9
On the Connecting Computer and Software	
Required for Operation	10
Location and Function of Parts and Controls ...	11
Front.....	11
Rear.....	12
Connection	13
Checking the Supplied Accessories	13
Checking the Position and Orientation of Connectors	13
Connecting the HDMI Cable	13
Connecting the USB Type-C Cable	13
Connecting the AC Adaptor	14
Attaching Accessories	14
Viewing the Content	15
Turning on the Unit	15
Using the Menu	15
Menu items	16
Troubleshooting	17
Checking the Latest Information on the Support Site	17
Specifications	18
NOTICES AND LICENSES FOR SOFTWARE USED IN THIS PRODUCT	19

- The terms HDMI and HDMI High-Definition Multimedia Interface, and the HDMI Logo are trademarks or registered trademarks of HDMI Licensing Administrator, Inc. in the United States and other countries.
- USB Type-C™ and USB-C™ are trademarks of USB Implementers Forum.

Before operating the unit, please read this manual thoroughly and retain it for future reference.

NOT FOR CANADIAN CUSTOMERS. NOT APPLICABLE IN CANADA, INCLUDING IN THE PROVINCE OF QUEBEC. NE S'ADRESSE PAS AUX CONSOMMATEURS CANADIENS. NON APPLICABLE AU CANADA, Y COMPRIS LA PROVINCE DE QUÉBEC.

Owner's Record

The model and serial numbers are located at the bottom of the unit. Record these numbers in the space provided below. Refer to these numbers whenever you call upon your Sony dealer regarding this product.

Model No. _____

Serial No. _____

Important Safety Instructions

- Read these instructions.
- Keep these instructions.
- Heed all warnings.
- Follow all instructions.
- Do not use this apparatus near water.
- Clean only with dry cloth.
- Do not block any ventilation openings. Install in accordance with the manufacturer's instructions.
- Do not install near any heat sources such as radiators, heat registers, stoves, or other apparatus (including amplifiers) that produce heat.
- Do not defeat the safety purpose of the polarized or grounding-type plug. A polarized plug has two blades with one wider than the other. A grounding-type plug has two blades and a third grounding prong. The wide blade or the third prong are provided for your safety. If the provided plug does not fit into your outlet, consult an electrician for replacement of the obsolete outlet.
- Protect the power cord from being walked on or pinched particularly at plugs, convenience receptacles, and the point where they exit from the apparatus.
- Only use attachments/accessories specified by the manufacturer.
- Use only with the cart, stand, tripod, bracket, or table specified by the manufacturer, or sold with the apparatus. When a cart is used, use caution when moving the cart/apparatus combination to avoid injury from tip-over.



- Unplug this apparatus during lightning storms or when unused for long periods of time.
- Refer all servicing to qualified service personnel. Servicing is required when the apparatus has been damaged in any way, such as power-supply cord or plug is damaged, liquid has been spilled or objects have fallen into the apparatus, the apparatus has been exposed to rain or moisture, does not operate normally, or has been dropped.

WARNING

To reduce the risk of fire or electric shock, do not expose this apparatus to rain or moisture. To avoid electrical shock, do not open the cabinet. Refer servicing to qualified personnel only.

WARNING

When installing the unit, incorporate a readily accessible disconnect device in the fixed wiring, or connect the power plug to an easily accessible socket-outlet near the unit. If a fault should occur during operation of the unit, operate the disconnect device to switch the power supply off, or disconnect the power plug.

WARNING

Do not touch the AC adapter, AC power cord and its plug with wet hands as it may cause electric shock.

WARNING

The apparatus shall not be exposed to dripping or splashing. No objects filled with liquids, such as vases, shall be placed on the apparatus.

WARNING

Excessive sound pressure from speakers while using the product can cause hearing loss. In order to use this product safely, avoid prolonged listening at excessive sound pressure levels.

WARNING

Operation of this equipment in a residential environment could cause radio interference.

NOTE ON AC ADAPTER**Warning**

To reduce the risk of fire or electric shock, do not expose this apparatus to rain or moisture. To prevent fire or shock hazard, do not place objects filled with liquids, such as vases, on the apparatus.

Do not install this equipment in a confined space, such as a bookshelf or similar unit.

- Please ensure that the AC outlet is installed near the equipment and shall be easily accessible.
- Be sure to use the supplied AC adapter and AC power cord.
- Do not use any other AC adapter. It may cause a malfunction.
- Connect the AC adapter to an easily accessible AC outlet.
- Do not coil the AC power cord around the AC adapter. The core wire may be cut and/or it may cause a malfunction of the display.

- Do not touch the AC adapter with wet hands.
- If you notice an abnormality in the AC adapter, disconnect it from the AC outlet immediately.
- The set is not disconnected from the AC source as long as it is connected to the AC outlet, even if the set itself has been turned off.

CAUTION

For safety, do not connect the connector for peripheral device wiring that might have excessive voltage to the following ports:

- Communication control connector

This equipment is not suitable for use in locations where children are likely to be present. Store the equipment away from children.

When installing the installation space must be secured in consideration of the ventilation and service operation.

- Leave a space around the unit for ventilation.
- Leave more than 10 cm (4 in.) of space in the rear of the unit to secure the operation area.

When the unit is installed on the desk or the like, leave at least 10 cm (4 in.) of space in the left and right sides, 10 cm (4 in.) or more of space above the unit.

The ventilation of the unit and its vicinity should not be impeded by covering the unit with items such as newspapers, table cloths, curtains, etc.

No naked flame sources, such as lighted candles, should be placed on the apparatus.

Location of the identification label

- Labels for Model No., Serial No. and Power Supply rating are located on the bottom of the unit.
- Labels for AC adapter Model No. and Serial No. are located on the bottom of the AC adapter.

Optional Equipment

This equipment has been tested and found to comply with the limits set out in the EMC standards using a connection signal cable shorter than 3 meters.

For the customers in the U.S.A.

NOT FOR CANADIAN CUSTOMERS. NOT APPLICABLE IN CANADA, INCLUDING IN THE PROVINCE OF QUEBEC. NE S'ADRESSE PAS AUX CONSOMMATEURS CANADIENS. NON APPLICABLE AU CANADA, Y COMPRIS LA PROVINCE DE QUÉBEC.

FCC Related Information

Note: This equipment has been tested and found to comply with the limits for a Class B digital device, pursuant to Part 15 of the FCC Rules. These limits are designed to provide reasonable protection against harmful interference in a residential installation. This equipment generates, uses and can radiate radio frequency energy and, if not installed and used in accordance with the instructions, may cause harmful interference to radio communications. However, there is no guarantee that interference will not occur in a particular installation. If this equipment does cause harmful interference to radio or television reception, which can be determined by turning the equipment off and on, the user is encouraged to try to correct the interference by one or more of the following measures:

- Reorient or relocate the receiving antenna.
- Increase the separation between the equipment and receiver.
- Connect the equipment into an outlet on a circuit different from that to which the receiver is connected.
- Consult the dealer or an experienced radio/TV technician for help.

Pursuant to FCC regulations, you are cautioned that any changes or modifications not expressly approved in this manual could void your authority to operate this equipment.

Supplier's Declaration of Conformity	
Trade Name	: SONY
Model	: ELF-SR1
Responsible party	: Sony Electronics Inc.
Address	: 16535 Via Esprillo, San Diego, CA 92127 U.S.A.
Telephone Number	: 858-942-2230
<p>This device complies with part 15 of the FCC Rules. Operation is subject to the following two conditions: (1) This device may not cause harmful interference, and (2) this device must accept any interference received, including interference that may cause undesired operation.</p>	

For the customers in Canada

CAN ICES-3(B)/NMB-3(B)

INSTALLATION

- The display should be installed near an easily accessible AC power outlet.
- Do not install the display face up or down, upside down or on its side.
 - Do not install the display in hot, oily, humid, or excessively dusty places.
 - Do not install the display in places subject to extreme temperature, such as in direct sunlight, near a radiator or a heating vent. The display may overheat in such conditions which can cause deformation of the enclosure and/or display malfunction.
 - Do not install the display in a place exposed to direct air conditioning; moisture may condense inside and may cause display malfunction.
 - Do not install the display where it may be exposed to mechanical vibration.
 - Do not install the display where insects may enter.
 - Do not install the display in a location where it may protrude, such as on or behind a pillar, or any place you might bump your head or receive bodily injury.
 - To prevent fire keep flammable objects or open flame (e.g. candles) away from the display.
 - Do not place optional equipment on top of the display.

Prevent the display from toppling over

Take measures to prevent the display from toppling over and causing injury or damage to the display and property.

- Never install the display on unstable and/or uneven surfaces.
- Do not install the display on furniture that can easily be used as steps, such as a chest of drawers.
- Care should be taken to install the display where it cannot be pushed, pulled over, or knocked down.
- Care should be taken to route all AC power cords and connecting cables so that they cannot be pulled or grabbed by curious children.

Medical institutions

Do not place this display in a place where medical equipment is in use. It may cause a medical equipment malfunction.

Do not place this product close to medical devices.

This product (including accessories) has magnet(s) which may interfere with pacemakers, programmable shunt valves for hydrocephalus treatment, or other medical devices. Do not place this product close to persons who use such medical devices. Consult your doctor before using this product if you use any such medical device.

Keep out of the reach of children or the supervised individuals.

This product (including accessories) has magnet(s). Swallowing magnet(s) could cause serious harm, such as choking hazard or intestinal injuries. If magnets (or a magnet) were swallowed, consult a doctor immediately.

Outdoor use

Do not install this display outdoors. The display should not be exposed to rain or direct sunlight in order to avoid damage and possible fire or electric shock.

Do not install this display in a vehicle, ship or other vessel

- Excessive bumping motion of a moving vehicle or continuous swaying motion on a boat may cause the display to fall down and cause injury.
- Exposing the display to seawater may cause a fire, electric shock or damage to your display.

Clean the AC power plug

Unplug the AC power plug and clean it occasionally to avoid dust from accumulating.

While cleaning, look for signs of damage. A damaged AC power cord should never be used.

SERVICING

Do not use the display if you suspect the display is damaged or if the display is damaged.

- Do not attempt to service the display yourself since opening the cabinet may expose you to dangerous voltage levels or other hazards. Refer all servicing to qualified service personnel.
- If replacement parts are required, acquire a written certification from the service technician which states that adequate replacement parts with the same or similar characteristics as the original parts have been used. Unauthorized substitutions may result in a fire, an electric shock or other hazards.

Safety check

Upon completion of any display servicing or repair, ask the service technician to perform routine safety checks as specified by Sony and to certify that the display is safe to operate. Have a qualified service technician dispose of the display if it is not safe to operate.

Precaution

On Safety

- Operate the unit only with a power source as specified in the “Specifications” section.
- A nameplate indicating operating voltage, etc., is located on the bottom of the unit.
- Should any solid object or liquid fall into the cabinet, unplug the unit and have it checked by qualified personnel before operating it any further.
- Do not drop or place heavy objects on the power cord. If the power cord is damaged, turn off the power immediately. It is dangerous to use the unit with a damaged power cord.
- Unplug the unit from the wall outlet if it is not to be used for several days or more.
- Disconnect the power cord from the AC outlet by grasping the plug, not by pulling the cord.
- The socket-outlet shall be installed near the equipment and shall be easily accessible.

On Installation

- Allow adequate air circulation to prevent internal heat build-up.
Do not place the unit on surfaces (rugs, blankets, etc.) or near materials (curtains, draperies) that may block the ventilation holes.
- Do not install the unit in a location near heat sources such as radiators or air ducts, or in a place subject to direct sunlight, excessive dust, mechanical vibration or shock.

When installing the installation space must be secured in consideration of the ventilation and service operation.

- Do not block the ventilation slots on the side and bottom of the unit.
- Leave a space around the unit for ventilation.
- Leave more than 10 cm (4 in.) of space in the rear of the unit to secure the operation area.

When the unit is installed on the desk or the like, leave at least 10 cm (4 in.) of space in the left and right sides, 10 cm (4 in.) or more of space above the unit.

Connecting to Other Devices

When connecting this unit to other devices, turn off this unit and the other devices beforehand.

Connecting while turned on may cause a malfunction to this unit and the other devices.

Handling the Screen

- The LCD panel fitted to this unit is manufactured with high precision technology, giving a functioning pixel ratio of at least 99.99%. Thus a very small proportion of pixels may be “stuck”, either always off (black), always on (red, green, or blue), or flashing. In addition, over a long period of use, because of the physical characteristics of the liquid crystal display, such “stuck” pixels may appear spontaneously. These problems are not a malfunction.
- Do not leave the screen facing the sun as it can damage the screen. Take care when you place the unit by a window.
- Do not push or scratch the display’s screen. Do not place a heavy object on the display’s screen. This may cause the screen to lose uniformity.
- If the unit is used in a cold place, horizontal lines or a residual image may appear on the screen. This is not a malfunction. When the display becomes warm, the screen returns to normal.
- The screen may become warm during operation. This is not a malfunction.

On a Long Period of Use

Due to an LCD’s panel structure and characteristics of materials in its design, displaying static images for extended periods, or using the unit repeatedly in a high temperature/high humidity environments may cause image smearing, burn-in, areas of which brightness is permanently changed, lines, or a decrease in overall brightness.

In particular, continually displaying an image smaller than the displaying area, such as an image in a different aspect ratio or with a frame, may expedite the above issues.

Avoid displaying a still image for an extended period, or using the unit repeatedly in a high temperature/high humidity environment such as an airtight room, or around the outlet of an air conditioner.

To prevent any of the above issues, we recommend reducing brightness slightly, and to

turn off the power whenever the unit is not in use.

On Dew Condensation

If the unit is suddenly taken from a cold to a warm location, or if ambient temperature suddenly rises, moisture may form on the outer surface of the unit and/or inside of the unit. This is known as condensation. If condensation occurs, turn off the unit and wait until the condensation clears before operating the unit. Operating the unit while condensation is present may damage the unit.

On Watching 3D Video Images

Some people may experience discomfort (such as eye strain, fatigue, or nausea) while watching 3D video images or playing stereoscopic 3D games. Sony recommends that all viewers take regular breaks while watching 3D video images or playing stereoscopic 3D games. The length and frequency of necessary breaks will vary from person to person. You must decide what works best. If you experience any discomfort, you should stop watching the 3D video images or playing stereoscopic 3D games until the discomfort ends; consult a doctor if you believe necessary. You should also review (i) the instruction manual of any other device or media used with this product and (ii) our website (<http://www.sony.com/support>) for the latest information. The vision of young children (especially those under six years old) is still under development.

Consult your doctor (such as a pediatrician or eye doctor) before allowing young children to watch 3D video images or play stereoscopic 3D games. Adults should supervise young children to ensure they follow the recommendations listed above.

Handling and Maintenance of the Screen

The surface of the screen is specially coated to reduce image reflection. Make sure to observe the following points as improper maintenance procedures may impair the screen's performance. In addition, the screen is vulnerable to damage. Do not scratch or knock against it using a hard object.

- Do not throw anything at the display as the impact can cause the screen glass to crack, break, or scatter.
- Be sure to disconnect the AC power cord from the AC outlet before performing maintenance.
- The surface of the screen is specially coated. Do not attach adhesive objects, such as stickers, on it.
- The surface of the screen is specially coated. Do not touch the screen directly.
- Wipe the screen surface gently with the supplied cleaning cloth to remove dirt.
- Stubborn stains may be removed with the supplied cleaning cloth slightly dampened with a mild detergent solution.
- The screen may become scratched if the supplied cleaning cloth is dusty.
- Never use strong solvents such as alcohol, benzene, thinner, acidic or alkaline detergent, detergent with abrasives, or chemical wipe as these may damage the screen.
- Use a blower to remove dust from the screen surface.

On Transportation of the Unit

- If the unit is transported or moved in a wrong way, the unit may fall over and cause an injury such as a bruise or fracture.
- Hold the unit securely as seen in the following illustration.

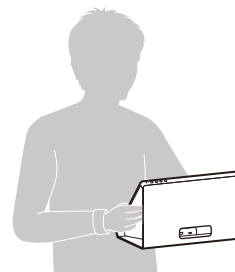

- Do not press or put pressure on the screen when holding the unit.
- Disconnect the AC power cord and all cables connected to the unit before transporting the unit.
If the unit is transported with the AC power cord connected, the AC power cord may be damaged and cause a fire and electrical shock.
- When transporting the unit for repair or moving, pack the unit using the original carton box and packing materials.
- Do not subject the unit to severe vibration or high impact conditions during transportation. Doing so may result in deformation of the internal structure or exterior of the unit,

damage of the screen, malfunction of the internal parts, or other damage.
Make sure not to expose the unit to strong vibration or high impact when you transport the unit as cargo by truck, ship, or air, or as luggage with a rolling luggage bag.

Disposal of the Unit

- Do not dispose of the unit with general waste. Do not include the display with household waste.
- When you dispose of the display, you must obey the law in the relative area or country.

Notes

- Always verify that the unit is operating properly before use. SONY WILL NOT BE LIABLE FOR DAMAGES OF ANY KIND INCLUDING, BUT NOT LIMITED TO, COMPENSATION OR REIMBURSEMENT ON ACCOUNT OF THE LOSS OF PRESENT OR PROSPECTIVE PROFITS DUE TO FAILURE OF THIS UNIT, EITHER DURING THE WARRANTY PERIOD OR AFTER EXPIRATION OF THE WARRANTY, OR FOR ANY OTHER REASON WHATSOEVER.
- SONY WILL NOT BE LIABLE FOR CLAIMS OF ANY KIND MADE BY USERS OF THIS UNIT OR MADE BY THIRD PARTIES.
- SONY WILL NOT BE LIABLE FOR THE TERMINATION OR DISCONTINUATION OF ANY SERVICES RELATED TO THIS UNIT THAT MAY RESULT DUE TO CIRCUMSTANCES OF ANY KIND.

On the Viewing Environment

Stereoscopic content such as 3DCG can stereoscopically be viewed with the naked eye on the unit. Place the unit on the desk and enjoy viewing it in the following environment.

Room illuminance: Approx. 100 to 1,000 lx and 100 lx and over for the surface of the face

Viewing distance: 30 cm to 75 cm (11 ⁷/₈ inches to 29 ⁵/₈ inches)

(35 cm to 50 cm (13 ⁷/₈ inches to 19 ³/₄ inches) recommended)

Viewing angle (horizontal): ±25°

Viewing angle (vertical): -40°/+20°

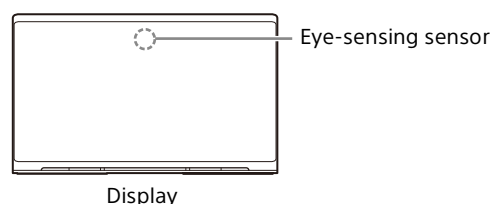

Overhead view

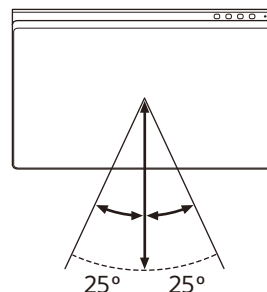

Side view

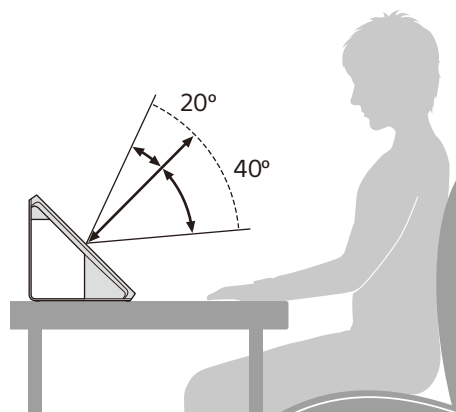

Notes

- For details on room illuminance and other information, see the following support site for developers.
<https://www.sony.net/dev-srd>
- View the unit avoiding direct outside light on the display.
Stereoscopic images may not be viewable due to the light reflected on the display.
- Do not place the unit in an environment where the eye-sensing sensor is facing a light source.
- The unit displays an optimized image by detecting the viewer's face and recognizing the eye-gaze of the viewer with the eye-sensing sensor. Take off masks and hats when viewing the unit.
- The unit has been designed for users to view images by placing it horizontally. If the unit is placed vertically, you cannot view images in 3D.
- When the viewing image is unstable, adjust the viewing environment including the installation position.
The eye-sensing sensor may be having difficulty recognizing your eye-gaze.

On the Connecting Computer and Software Required for Operation

Use a computer with the recommended specifications. A dedicated software is required to display the content. Obtain the necessary software to install on your computer. For details on the recommended specifications and operating environment of the computer, dedicated software, and manual, refer to the following site.
<https://www.sony.net/dev-srd>



Location and Function of Parts and Controls

Front

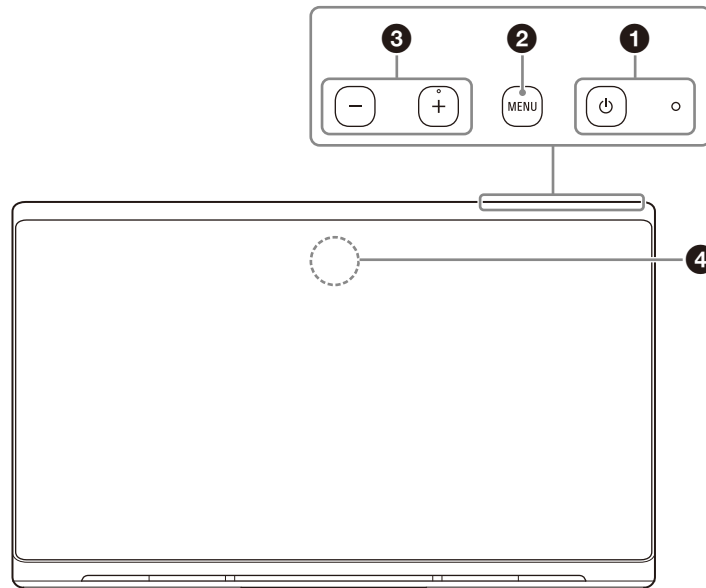

❶ (Power) switch and indicator

Press to turn on the unit.

The indicator lights in white when the unit enters the operating state.

Press again to turn off the unit and indicator.

❷ MENU button

Press to turn on/off the on-screen menu.

When the on-screen menu is displayed, press to move the cursor to select a menu item.

❸ +/- button

Press to adjust the volume.

When the on-screen menu is displayed, press to change the setting value of the menu item (page 15).

❹ Eye-sensing sensor

Detects the viewer's face and recognizes the eye-gaze of the viewer.

Rear

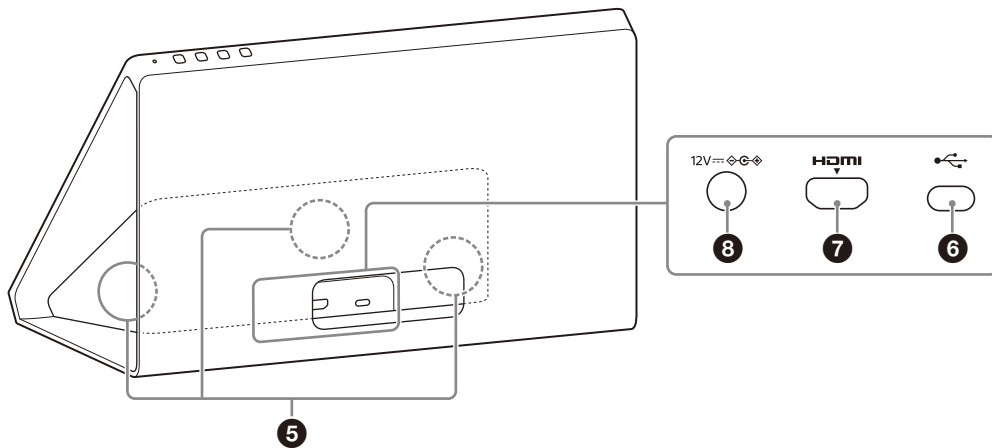

5 Speaker
Outputs audio.

6  **(Communication control) connector**
Connect the supplied USB Type-C cable.

7 HDMI (HDMI) input connector
Inputs the HDMI signal.
Connect to the HDMI output connector on the computer with the supplied HDMI cable.

8 12V \equiv (DC input) connector
Connect the DC connector of the supplied AC adaptor.

Connection

Checking the Supplied Accessories

Check the following accessories before connection.

Also, refer to the operation manual of the connecting devices.

- Display (1)
- Side panel (2) (Both can be used for either the left or the right side)
- Top flange (1)
- Bottom stand (1)
- USB Type-C cable (1)
- HDMI cable (1)
- AC adaptor (1)
- AC power cord (1)
- Operating Instructions (this manual) (1)
- Cleaning cloth (1)

Checking the Position and Orientation of Connectors

Check the position, shape, and orientation of connectors on the rear of the unit.

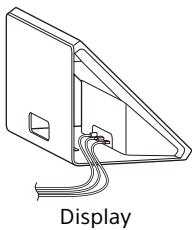
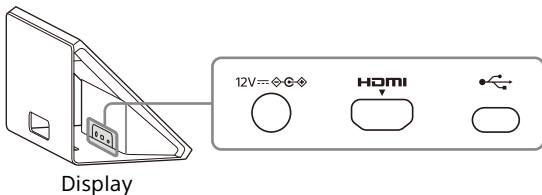

Note

Cables can be pulled out from the hole at the lower part of the rear of the unit or the bottom of the unit.

Connecting the HDMI Cable

Connect the HDMI input connector of the unit and the HDMI output connector of your computer with the supplied HDMI cable.

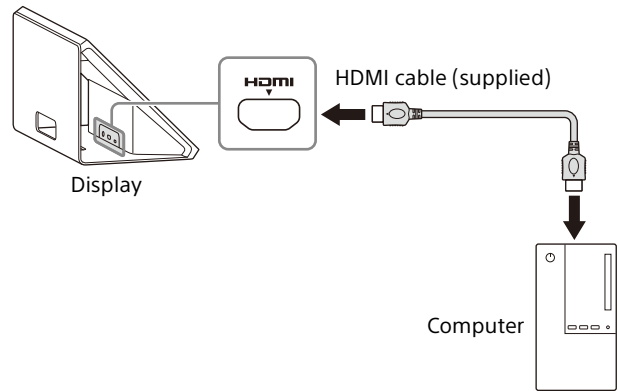

Notes

- Be sure to use the supplied HDMI cable for connection.
- Directly connect to the computer without using an HDMI switcher or other devices.
- Check the position and orientation of the connector and cable before connecting the cable to the connector.
- Before connecting, make sure the HDMI connector supported by your computer supports HDMI 2.0 or higher to ensure the original image can be displayed on the unit. For details, see the operating instructions for your computer.

Connecting the USB Type-C Cable

Connect the  (Communication control) connector of the unit and the USB connector of your computer with the supplied USB Type-C cable.

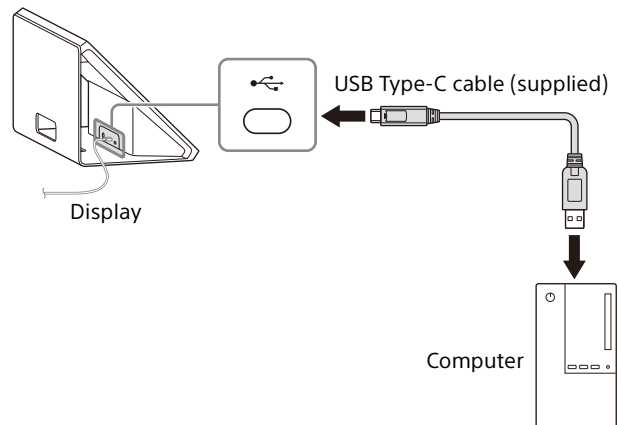

Notes

- Be sure to use the supplied USB Type-C cable for connection.
- Directly connect to the computer without using a USB hub or other devices.
- Check the position and orientation of the connector and cable before connecting the cable to the connector.
- Before connecting, make sure the USB connector supported by your computer supports USB 3.2 or higher to ensure the original image can be displayed on the unit. For details, see the operating instructions for your computer.

Connecting the AC Adaptor

Insert the DC connector of the supplied AC adaptor straight into the 12V \equiv (DC input) connector of the unit to connect them.

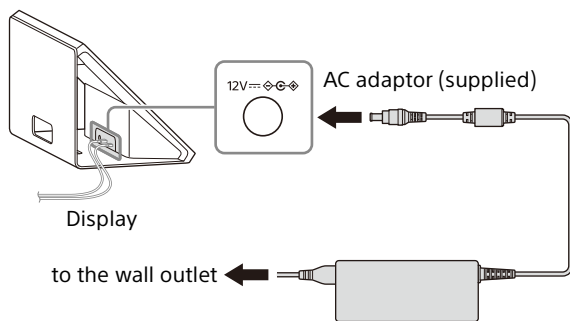

Attaching Accessories

Stereoscopic images can be viewed easily with naked eyes by attaching accessories which may bring about a stronger sense of immersion. Make sure to attach accessories when viewing the unit.

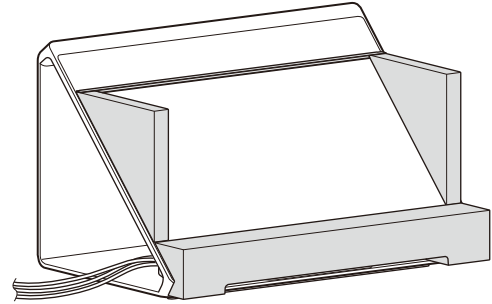

Notes

- Remove accessories when moving the display.
- Do not lift or move the display by holding the side panels.

1 Attach the bottom stand.

Insert the tab of the bottom stand into the space under the bottom of the unit and push the bottom stand until it stops.

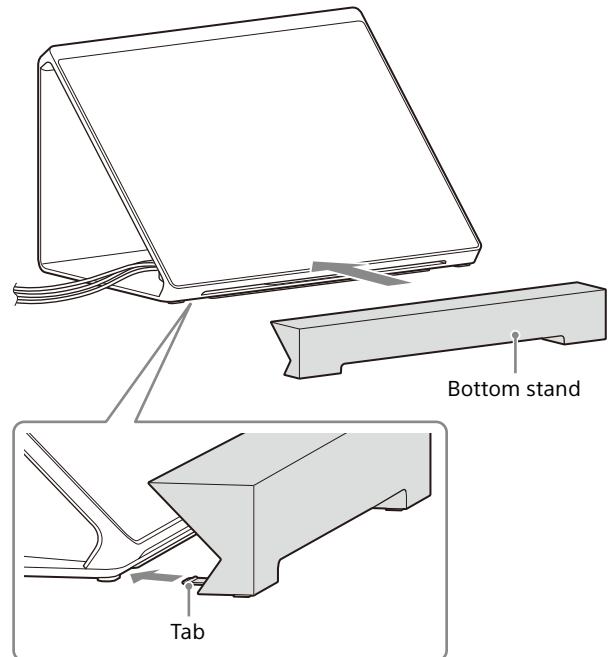

2 Attach the side panels.

Remove the protection film on the side panels, then place the side panels on the display as seen in the following illustration with the glossy side facing inward toward the screen.

The side panels attach to the display panel with the magnets on the bottom of the side panels.

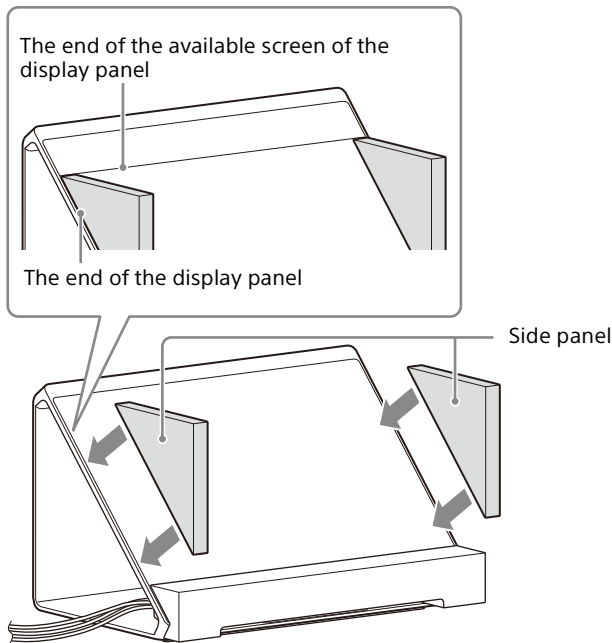

3 Attach the top flange.

Insert the top flange into the space between the side panel and display panel as seen in the following illustration.

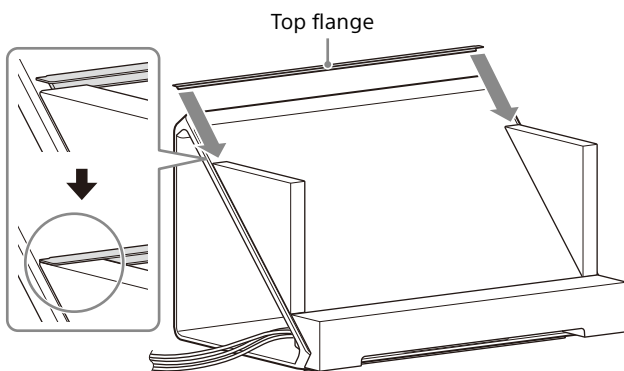

Note

To remove accessories, first remove the top flange.

Viewing the Content

Turning on the Unit

- 1 Connect the AC power cord to the AC outlet.
- 2 Press the  (Power) switch to turn on the unit.

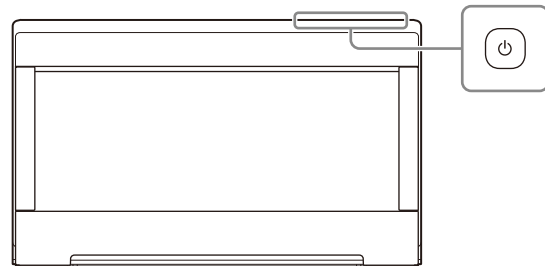

Note

The indicator lights in white when the unit is turned on.



Using the Menu

Picture quality adjustment and settings can be made on the menu screen of the unit.

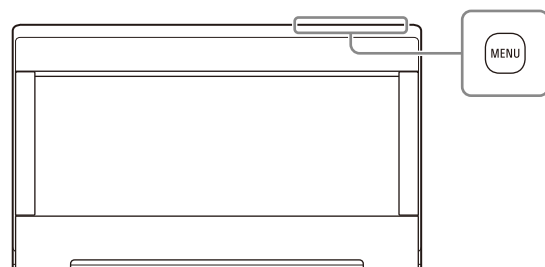
- 1 Press the MENU button to display the menu.

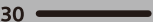

The item currently selected on the menu is shown in gray.

Brightness	30	
Contrast	30	
Language 	English	
Auto shut-off	On	
Text to speech	Off	

- 2** Press the MENU button to select the menu item.

The selected item goes down from the top by pressing the MENU button.

- 3** Press the +/- button to change the values and settings.

The adjusted values and settings are stored automatically.

When changing the value:

Press the + button to increase the value.

Press the - button to decrease the value.

When selecting the setting:

Press the +/- button to select the setting.

To clear the menu

If you press the MENU button while selecting the menu item at the very bottom, "Information screen" appears.

Press the MENU button again to clear the screen.

Also, the menu screen disappears automatically if you do not operate the menu for a while.

Menu items

Menu	Setting
Brightness	Adjusts brightness. (Default value: 30)
Contrast	Adjusts contrast. (Default value: 30)
Language	You can select the menu or message language. <ul style="list-style-type: none">• English (Default setting)• Français
Auto shut-off	The unit enters into standby mode automatically after a certain period of no signal input. <ul style="list-style-type: none">• On (Default setting)• Off

Note

In standby mode, no image is displayed on the screen and the indicator lights in orange.

Menu	Setting
Text to speech	Reads out the menu and message displayed on the screen. <ul style="list-style-type: none">• On• Off (Default setting)

Note

This function is not available when "Français" is selected in "Language."

Information screen	Displays information of the unit. <ul style="list-style-type: none">• Model name• Serial No.• Software Version
--------------------	------------------------------------------------------------------------------------------------------------------------------------------------

Troubleshooting

This section may help you isolate the cause of a problem and as a result, eliminate the need to contact technical support.

- **No screen image or audio** → When the indicator flashes in orange, unplug the AC power cord and wait until the indicator stops flashing. Then, plug the AC power cord again and turn on the unit with the  (Power) switch. If the indicator is still flashing, check how many times the indicator flashes and consult qualified Sony service personnel.
- **Image is not displayed correctly** → Check if your environment is suitable for viewing the unit (page 9).
- **The screen becomes dark/no image is displayed (after a certain period passed)** → "Auto shut-off" is enabled. Check the "Auto shut-off" setting (page 16).
- **"No signal" is displayed** → No signal is input to the unit.
- **"Unsupported signal" is displayed** → Some signals may not be supported on the unit depending on the input signal. Check the supported signal of your computer.
- **The content appears to be displayed in low resolution ("Unsupported signal" is not displayed)** → Check that your computer's resolution/supported signal is set to 3840 × 2160.

Depending on the specifications of your computer's GPU or OS, "Unsupported signal" is not displayed on the unit even when it is set to a resolution/supported signal other than 3840 × 2160. Check the settings on your computer.

Checking the Latest Information on the Support Site

The following information can be found on the support site for developers.

<https://www.sony.net/dev-srd>



- Development information on content
- Troubleshooting (Q & A)
- Software update information
- Connection information with other devices
- Specification information on recommended computers

Sony Customer Support

U.S.A.:

<http://www.sony.com/support>

Canada:

<http://www.sony.ca/support>

Specifications

Panel system	Micro optical lens LCD panel module
Panel size (diagonal)	39.6 cm (15.6 inches)
Panel aspect ratio	16:9
Number of panel pixels (H × V)	3,840 × 2,160 pixels The actual effective resolution for the stereoscopic view is 4K or lower.
Effective picture size* ¹ (H × V)	341.4 mm × 190.7 mm (13 1/2 inches × 7 5/8 inches)
Audio output	5.5 W (1.5 W + 1.5 W + 2.5 W)
 (Communication control) connector	USB 3.2 Gen1 correspondence
HDMI input connector	3840 × 2160p (60Hz), 720 × 480p (60Hz)* ² , 640 × 480p (60Hz)* ²
Operating conditions	
Temperature	0 °C to 40 °C (32 °F to 104 °F)
Recommended temperature	20 °C to 30 °C (68 °F to 86 °F)
Humidity	20% to 80% (no condensation)
Altitude	2,000 m (approx. 6,560 feet) and lower
Storage and transport conditions	
Temperature	-20 °C to +60 °C (-4 °F to +140 °F)
Humidity	20% to 80%
Power consumption	Max. 24 W
Maximum external dimensions* ¹ (excluding the projecting parts) (w/h/d)	383 mm × 232 mm × 231 mm (15 1/8 inches × 9 1/4 inches × 9 1/8 inches)
	383 mm × 232 mm × 247 mm (15 1/8 inches × 9 1/4 inches × 9 3/4 inches) (including accessories* ³)
Mass* ¹	4.6 kg (10.2 lb) 4.9 kg (10.8 lb) (including accessories* ³)
Power	DC IN: 12 V 2.0 A (supplied from the AC adaptor)

*¹ Effective picture size, maximum external dimensions, and mass are approximate values.

*² For 2D display only

*³ Accessories (the side panels, bottom stand, and top flange) are included.

Design and specifications are subject to change without notice.

NOTICES AND LICENSES FOR SOFTWARE USED IN THIS PRODUCT

END USER LICENSE AGREEMENT

IMPORTANT:

BEFORE USING THE SOFTWARE, PLEASE READ THIS END USER LICENSE AGREEMENT ("EULA") CAREFULLY. BY USING THE SOFTWARE YOU ARE AGREEING TO BE BOUND BY THE TERMS OF THIS EULA. IF YOU DO NOT AGREE TO THE TERMS OF THIS EULA, YOU MAY NOT USE THE SOFTWARE.

This EULA is a legal agreement between (i) you and any entity you represent ("you") and (ii) Sony Electronics Inc. ("SONY"). This EULA governs your rights and obligations regarding the software of SONY and/or its third party licensors (including SONY's affiliates) and their respective affiliates (collectively, the "THIRD-PARTY SUPPLIERS") made available to you by SONY, as embedded in certain device ("DEVICE"), together with any updates/upgrades provided by SONY, any printed, on-line or other electronic documentation for such software, and any data files created by operation of such software (collectively, the "SOFTWARE").

Notwithstanding the foregoing, any software in the SOFTWARE having a separate end user license agreement (including, but not limited to, GNU General Public license and Lesser/Library General Public License) shall be covered by such applicable separate end user license agreement in lieu of the terms of this EULA to the extent required by such separate end

user license agreement ("EXCLUDED SOFTWARE").

SOFTWARE LICENSE

The SOFTWARE is licensed, not sold. The SOFTWARE is protected by copyright and other intellectual property laws and international treaties.

COPYRIGHT

All right and title in and to the SOFTWARE (including, but not limited to, any images, photographs, animation, video, audio, music, text, "applets" and other content incorporated into the SOFTWARE) is owned by SONY or one or more of the THIRD-PARTY SUPPLIERS.

GRANT OF LICENSE

SONY grants you a limited, non-exclusive, personal, non-transferable license to use the SOFTWARE solely in connection with your DEVICE solely in accordance with this EULA and the usage as intended in the relevant instructions and directions for use made available to you by SONY ("USAGE INSTRUCTIONS"). SONY and the THIRD-PARTY SUPPLIERS expressly reserve all rights, title and interest (including, but not limited to, all intellectual property rights) in and to the SOFTWARE that this EULA does not specifically grant to you.

REQUIREMENTS AND LIMITATIONS

You may not copy, publish, adapt, redistribute, attempt to derive source code, modify, reverse engineer, decompile, or disassemble any of the SOFTWARE, whether in whole or in part, or create any derivative works from or of the SOFTWARE unless such derivative works are intentionally facilitated by the SOFTWARE. You may not modify or tamper with any digital rights management functionality of

the SOFTWARE. You may not bypass, modify, defeat or circumvent any of the functions or protections of the SOFTWARE or any mechanisms operatively linked to the SOFTWARE. You may not separate any individual component of the SOFTWARE for use on more than one DEVICE unless expressly authorized to do so by SONY. You may not remove, alter, cover or deface any trademarks or notices on the SOFTWARE. You may not share, distribute, rent, lease, sublicense, assign, transfer or sell the SOFTWARE. You may not use the SOFTWARE in any manner non-compliant with the USAGE INSTRUCTIONS. The software or other products other than SOFTWARE upon which the SOFTWARE'S performance depends might be interrupted or discontinued at the discretion of the suppliers (software suppliers or SONY). SONY and such suppliers do not warrant that the SOFTWARE or other products will continue to be available, or will operate without interruption or modification. You shall not, nor shall you instruct or permit, procure, enable or request any third party (including your users, third party personnel or other personnel, staff or contractors) to, take any action designed or intended to: (i) use the SOFTWARE (or any part thereof) in any manner or for any purpose that is inconsistent with this EULA; (ii) introduce to the SOFTWARE any "back door," "drop dead device," "time bomb," "Trojan horse," "virus," or "worm" (as such terms are commonly understood in the software industry) or any other equivalent code, files, scripts, agents, programs, software routine or instructions designed or intended to disrupt, disable, harm or otherwise impede in any manner the operation of the SOFTWARE or any device or

system owned or controlled by you or any third party, or which otherwise may damage or destroy any data or file ("Malicious Code"); (iii) interfere with the proper working of the SOFTWARE; (iv) circumvent, disable, or interfere with security-related features of the SOFTWARE or features that prevent or restrict use, access to, or copying the SOFTWARE, or that enforce limitations on use of the SOFTWARE; or (v) impose (or which may impose, in your sole discretion) an unreasonable or disproportionately large load on the SOFTWARE.

EXCLUDED SOFTWARE AND OPEN SOURCE COMPONENTS

Notwithstanding the foregoing limited license grant, you acknowledge that the SOFTWARE may include EXCLUDED SOFTWARE. Certain EXCLUDED SOFTWARE may be covered by open source software licenses ("OPEN SOURCE COMPONENTS"), which means any software licenses approved as open source licenses by the Open Source Initiative or any substantially similar licenses, including but not limited to any license that, as a condition of distribution of the software licensed under such license, requires that the distributor make the software available in source code format. If and to the extent disclosure is required, please visit www.sony.net/Products/Linux or other SONY-designated web site for a list of applicable OPEN SOURCE COMPONENTS included in the SOFTWARE from time to time, and the applicable terms and conditions governing its use. Such terms and conditions may be changed by the applicable third party at any time without liability to you. To the extent required by the licenses covering EXCLUDED

SOFTWARE, the terms of such licenses will apply in lieu of the terms of this EULA. To the extent the terms of the licenses applicable to EXCLUDED SOFTWARE prohibit any of the restrictions in this EULA with respect to such EXCLUDED SOFTWARE, such restrictions will not apply to such EXCLUDED SOFTWARE. To the extent the terms of the licenses applicable to OPEN SOURCE COMPONENTS require SONY to make an offer to provide source code in connection with the SOFTWARE, such offer is hereby made.

USE OF SOFTWARE WITH COPYRIGHTED MATERIALS

The SOFTWARE may be capable of being used by you to view, store, process and/or use content created by you and/or third parties. Such content may be protected by copyright, other intellectual property laws, and/or agreements. You agree to use the SOFTWARE only in compliance with all such laws and agreements that apply to such content. You acknowledge and agree that SONY may take appropriate measures to protect the copyright of content stored, processed or used by the SOFTWARE. Such measures include, but are not limited to, counting the frequency of your backup and restoration through certain SOFTWARE features, refusal to accept your request to enable restoration of data, and termination of this EULA in the event of your illegitimate use of the SOFTWARE.

EXPORT AND OTHER REGULATIONS

You agree to comply with all export and re-export restrictions and regulations of the Department of Commerce and other United States agencies and authorities, and not to transfer, or authorize the transfer, of the SOFTWARE to a

prohibited country or otherwise in violation of any such restrictions or regulations.

U.S. GOVERNMENT RESTRICTED RIGHTS

Use, duplication, or disclosure by the United States Government is subject to restriction as set forth in subparagraph (c) (1) and (2) of the Commercial Computer Software-Restricted Rights at 48 C.F.R. § 52.227-19, as applicable. The manufacturer solely for purposes of this section is Sony Electronics Inc., 16535 Via Esprillo, San Diego, CA 92127.

HIGH RISK ACTIVITIES

The SOFTWARE is not fault-tolerant and is not designed, manufactured or intended for use or resale as on-line control equipment in hazardous environments requiring fail-safe performance, such as in the operation of nuclear facilities, aircraft navigation or communication systems, air traffic control, direct life support machines, or weapons systems, in which the failure of the SOFTWARE could lead to death, personal injury, or severe physical or environmental damage ("HIGH RISK ACTIVITIES"). SONY, each of the THIRD-PARTY SUPPLIERS, and each of their respective affiliates specifically disclaim any express or implied warranty, duty or condition of fitness for HIGH RISK ACTIVITIES.

DISCLAIMER OF WARRANTIES ON SOFTWARE

You acknowledge and agree that use of the SOFTWARE is at your sole risk and that you are responsible for use of the SOFTWARE. The SOFTWARE is provided "AS IS," without warranty, duty or condition of any kind.

SONY AND EACH OF THE THIRD-PARTY SUPPLIERS (for purposes of this Section, SONY and each of the THIRD-PARTY SUPPLIERS shall be collectively referred to as "SONY") EXPRESSLY DISCLAIM ALL WARRANTIES, DUTIES OR CONDITIONS, EXPRESS OR IMPLIED, INCLUDING, BUT NOT LIMITED TO, THE IMPLIED WARRANTIES OF MERCHANTABILITY, NONINFRINGEMENT AND FITNESS FOR A PARTICULAR PURPOSE. SONY DOES NOT WARRANT OR MAKE ANY CONDITIONS OR REPRESENTATIONS (A) THAT THE FUNCTIONS CONTAINED IN ANY OF THE SOFTWARE WILL MEET YOUR REQUIREMENTS OR THAT THEY WILL BE UPDATED, (B) THAT THE OPERATION OF ANY OF THE SOFTWARE WILL BE CORRECT OR ERROR-FREE OR THAT ANY DEFECTS WILL BE CORRECTED, (C) THAT THE SOFTWARE WILL NOT DAMAGE ANY OTHER SOFTWARE, HARDWARE OR DATA, (D) THAT ANY SOFTWARE OR PRODUCTS (OTHER THAN THE SOFTWARE) UPON WHICH THE SOFTWARE'S PERFORMANCE DEPENDS WILL CONTINUE TO BE AVAILABLE, UNINTERRUPTED, TIMELY, SECURE OR UNMODIFIED, (E) THAT THE SOFTWARE OR ANY EQUIPMENT OR SYSTEM ON WHICH THE SOFTWARE IS USED (INCLUDING THE DEVICE) WILL BE FREE OF VULNERABILITY TO INTRUSION OR ATTACK AND (F) REGARDING THE USE OR THE RESULTS OF THE USE OF THE SOFTWARE IN TERMS OF ITS CORRECTNESS, ACCURACY, RELIABILITY, OR OTHERWISE. THE SERVICES MAY BE SUBJECT TO DELAYS, CANCELLATIONS, AND OTHER DISRUPTIONS. SONY MAKES NO WARRANTY, REPRESENTATION OR CONDITION WITH RESPECT TO THE SOFTWARE, INCLUDING BUT NOT LIMITED TO, THE QUALITY, EFFECTIVENESS,

REPUTATION, AND OTHER CHARACTERISTICS OF THE SERVICES.

NO ORAL OR WRITTEN INFORMATION OR ADVICE GIVEN BY SONY OR AN AUTHORIZED REPRESENTATIVE OF SONY SHALL CREATE A WARRANTY, DUTY OR CONDITION OR IN ANY WAY INCREASE THE SCOPE OF THIS WARRANTY. SHOULD THE SOFTWARE PROVE DEFECTIVE YOU ASSUME THE ENTIRE COST OF ALL NECESSARY SERVICING, REPAIR OR CORRECTION. SOME JURISDICTIONS DO NOT ALLOW THE EXCLUSION OF IMPLIED WARRANTIES, SO SOME OR ALL OF THESE EXCLUSIONS MAY NOT APPLY TO YOU.

LIMITATION OF LIABILITY

SONY AND EACH OF THE THIRD-PARTY SUPPLIERS (for purposes of this Section, SONY and each of the THIRD-PARTY SUPPLIERS shall be collectively referred to as "SONY") SHALL NOT BE LIABLE FOR ANY INDIRECT, INCIDENTAL, SPECIAL, EXEMPLARY OR CONSEQUENTIAL DAMAGES ARISING OUT OF OR IN CONNECTION WITH THE SOFTWARE AND/OR DEVICE, INCLUDING FOR BREACH OF ANY EXPRESS OR IMPLIED WARRANTY, BREACH OF CONTRACT, NEGLIGENCE, STRICT LIABILITY OR UNDER ANY OTHER LEGAL THEORY RELATED TO THE SOFTWARE, INCLUDING, BUT NOT LIMITED TO, ANY DAMAGES ARISING OUT OF LOSS OF PROFITS, LOSS OF REVENUE, LOSS OF DATA, LOSS OF USE OF THE SOFTWARE OR ANY ASSOCIATED HARDWARE, DOWN TIME AND USER'S TIME, EVEN IF ANY OF THEM HAVE BEEN ADVISED OF THE POSSIBILITY OF SUCH DAMAGES. IN ANY CASE, EACH AND ALL OF THEIR AGGREGATE LIABILITY UNDER ANY

PROVISION OF THIS EULA SHALL BE LIMITED TO THE GREATER OF THE AMOUNT ACTUALLY PAID BY YOU FOR THE SOFTWARE OR THE AMOUNT ACTUALLY PAID FOR THE DEVICE. SOME JURISDICTIONS DO NOT ALLOW THE EXCLUSION OR LIMITATION OF CERTAIN DAMAGES, SO SOME OR ALL OF THE ABOVE EXCLUSION OR LIMITATION MAY NOT APPLY TO YOU.

INDEMNITY

Except as prohibited by applicable law, you agree to indemnify and hold harmless SONY and the THIRD-PARTY SUPPLIERS and their respective subsidiaries, affiliates, officers and employees, from any loss, claim or demand, including reasonable attorneys' fees, made by any third party due to or arising out of your use of the SOFTWARE and/or the DEVICE (including, without limitation, any software vulnerability caused by such use), your violation of this EULA or your failure to fulfill your responsibility under this EULA.

UPDATE FEATURE

From time to time, SONY or the THIRD-PARTY SUPPLIERS may update or otherwise modify the SOFTWARE, including, but not limited to, for purposes of enhancement of security functions, error correction and improvement of functions. Such updates or modifications may delete or change the nature of features or other aspects of the SOFTWARE, including, but not limited to, functions you may rely upon. You acknowledge and agree that such updates may occur at SONY's sole discretion and that SONY may condition continued use of the SOFTWARE upon your complete installation or acceptance of such update or modifications. Any updates/modifications shall be deemed to be, and shall

constitute part of, the SOFTWARE for purposes of this EULA. By acceptance of this EULA, you consent to such update/modification.

FORCE MAJEURE

SONY shall not be liable for any delay or failure to perform resulting from causes outside its reasonable control or any other contingency beyond SONY's control not herein enumerated, including, but not limited to, acts of God, war, epidemics, pandemics, outbreaks, terrorism, riots, embargos, acts of civil or military authorities, fire, floods, accidents, strikes or shortages of transportation facilities, fuel, energy, labor or materials.

ENTIRE AGREEMENT, WAIVER, SEVERABILITY

This EULA as amended and modified from time to time, together constitute the entire agreement between you and SONY with respect to the SOFTWARE. The failure of SONY to exercise or enforce any right or provision of this EULA shall not constitute a waiver of such right or provision. If any part of this EULA is held invalid, illegal, or unenforceable, that provision shall be enforced to the maximum extent permissible so as to maintain the intent of this EULA, and the other parts will remain in full force and effect. The United Nations Convention on Contracts for the International Sale of Goods shall not apply to the SOFTWARE or this EULA. Furthermore, this EULA will not be governed or interpreted in any way by referring to any law based on the Uniform Computer Information Transactions Act (UCITA) or any other act derived from or related to UCITA.

BINDING ARBITRATION

ANY "DISPUTE" THAT IS NOT RESOLVED THROUGH THE INFORMAL NEGOTIATION PROCESS DESCRIBED ABOVE SHALL BE RESOLVED EXCLUSIVELY THROUGH BINDING ARBITRATION.

"DISPUTE" is defined as any disagreement, cause of action, claim, controversy, or proceeding between you and any Sony entity related to or arising out of the SOFTWARE or this EULA. DISPUTE is to be given the broadest possible meaning that will be enforced. If a DISPUTE arises, you agree to first give notice to SONY by contacting Sony Electronics Inc. at 16535 Via Esprillo, MZ 1105, San Diego, CA 92127, Attn: Legal Department, and engaging in good faith negotiations to attempt to resolve any DISPUTE for at least 14 days, except that you or Sony (or any of its affiliates) may skip this informal negotiation procedure for DISPUTE enforcing, protecting, or concerning the validity of intellectual property rights.

ARBITRATION INSTRUCTIONS

To begin arbitration, either you or SONY must make a written demand to the other for arbitration. The arbitration will take place before a single arbitrator. It will be administered in keeping with the Expedited Procedures of the Commercial Arbitration Rules, and the Supplementary Proceedings for Consumer-Related disputes when applicable ("Rules") of the American Arbitration Association ("AAA") in effect when the claim is filed. You may get a copy of AAA's Rules by contacting AAA at (800) 778-7879 or visiting www.adr.org. The filing fees to begin and carry out arbitration will be shared between you and SONY, but in no event shall your fees ever exceed the amount

allowable by the special rules for Consumers Disputes provided for by AAA, at which point SONY will cover all additional administrative fees and expenses. This does not prohibit the arbitrator from giving the winning party their fees and expenses of the arbitration when appropriate pursuant to the Rules. Unless you and SONY agree differently, the arbitration will take place in the county and state where you live, and applicable federal or state law shall govern the substance of any DISPUTE. The Federal Arbitration Act, 9 U.S.C. § 1, et seq., will govern the arbitration itself and not any state law on arbitration. The arbitrator's decision will be binding and final, except for a limited right of appeal under the Federal Arbitration Act. The arbitrator may award declaratory or injunctive relief only in favor of the party seeking relief, and only to the extent necessary to provide relief warranted by that party's individual claim. Any court with jurisdiction over the parties may enforce the arbitrator's decision.

SMALL CLAIMS EXCEPTION

Despite the provisions set forth above, you have the right to litigate any DISPUTE in small claims court or other similar court of limited jurisdiction, to the extent the amount at issue does not exceed \$15,000, and as long as such court has proper jurisdiction and all other requirements (including amount in controversy) are satisfied.

CLASS ACTION WAIVER YOU UNDERSTAND AND ACKNOWLEDGE THAT BY AGREEING TO BINDING ARBITRATION, YOU ARE GIVING UP THE RIGHT TO LITIGATE (OR PARTICIPATE IN

AS A PARTY OR CLASS MEMBER) ANY DISPUTES IN COURT BEFORE A JUDGE OR JURY. ANY DISPUTE RESOLUTION PROCEEDING WILL BE CONDUCTED ONLY ON AN INDIVIDUAL BASIS, AND BOTH PARTIES AGREE NOT TO HAVE ANY DISPUTE HEARD AS A CLASS ACTION, REPRESENTATIVE ACTION, CONSOLIDATED ACTION, OR PRIVATE ATTORNEY GENERAL ACTION, UNLESS ALL PARTIES INVOLVED IN THE DISPUTE SPECIFICALLY AGREE TO DO SO IN WRITING FOLLOWING INITIATION OF THE ARBITRATION.

OPT-OUT INSTRUCTIONS

IF YOU DO NOT WISH TO BE BOUND BY THE BINDING ARBITRATION PROVISION AND/OR THE CLASS ACTION WAIVER ABOVE, THEN: (1) YOU MUST NOTIFY SONY IN WRITING WITHIN 30 DAYS OF THE DATE THAT YOU FIRST USE THE SOFTWARE OR AGREE TO THIS EULA, WHICHEVER OCCURS FIRST; (2) YOUR WRITTEN NOTIFICATION MUST BE MAILED TO SONY ELECTRONICS INC., 16535 VIA ESPRILLO, MZ 1105, SAN DIEGO CA 92127, ATTN: LEGAL DEPARTMENT; AND (3) YOUR WRITTEN NOTIFICATION MUST INCLUDE: (A) YOUR NAME; (B) YOUR ADDRESS; (C) THE DATE YOU FIRST USED THE SOFTWARE OR AGREED TO THIS EULA; AND (D) A CLEAR STATEMENT THAT YOU DO NOT WISH TO RESOLVE DISPUTES WITH ANY SONY ENTITY THROUGH ARBITRATION AND/OR TO BE BOUND BY THE CLASS ACTION WAIVER.

REJECTING CHANGES MADE TO THE DISPUTE PROCEDURES

Despite anything to the contrary in this EULA, you may reject changes made to the binding arbitration provision and class action waiver if: (1) you've

already begun authorized use of the SOFTWARE at the time the change was/is made; and (2) you mail written notice to the address in the immediately preceding paragraph within 30 days after the particular change was/is made. Should such a situation arise, you will still be bound by the DISPUTE procedures you previously agreed to and existing before the change you rejected was made.

MISCELLANEOUS

Any DISPUTE determined not subject to arbitration and not initiated in small claims court will be litigated by either party in a court of competent jurisdiction in either the superior court for the County of San Diego or in the United States District Court for the Southern District of California.

EQUITABLE REMEDIES

Notwithstanding anything contained in this EULA to the contrary, you acknowledge and agree that any violation of or non-compliance with this EULA by you will cause irreparable harm to SONY, for which monetary damages would be inadequate, and you consent to SONY obtaining any injunctive or equitable relief that SONY deems necessary or appropriate in such circumstances. SONY may also take any legal and technical remedies to prevent violation of and/or to enforce this EULA, including, but not limited to, immediate termination of your use of the SOFTWARE, if SONY believes in its sole discretion that you are violating or intend to violate this EULA. These remedies are in addition to any other remedies SONY may have at law, in equity or under contract.

TERMINATION

Without prejudice to any of its other rights, SONY may terminate or suspend your access or use of the SOFTWARE and/or terminate this EULA if you fail to comply with any of its terms. In case of such termination, you must: (i) cease all use, and destroy any copies, of the SOFTWARE; (ii) comply with the requirements in the section below entitled "Your Account Responsibilities".

AMENDMENT

SONY RESERVES THE RIGHT TO AMEND ANY OF THE TERMS OF THIS EULA AT ITS SOLE DISCRETION BY POSTING NOTICE ON A SONY DESIGNATED WEB SITE, BY EMAIL NOTIFICATION TO AN EMAIL ADDRESS PROVIDED BY YOU, AND/OR BY PROVIDING NOTICE AS PART OF THE PROCESS IN WHICH YOU OBTAIN UPGRADES/UPDATES OR BY ANY OTHER LEGALLY RECOGNIZABLE FORM OF NOTICE. If you do not agree to the amendment, you should promptly contact SONY for instructions. Your continued use of the SOFTWARE after the effective date of any such notice shall be deemed your agreement to be bound by such amendment.

THIRD-PARTY BENEFICIARIES

Each THIRD-PARTY SUPPLIER is an express intended third-party beneficiary of, and shall have the right to enforce, each provision of this EULA with respect to the SOFTWARE of such party.

YOUR ACCOUNT RESPONSIBILITIES

Should you return your DEVICE to its place of purchase, sell or otherwise transfer your DEVICE, or if this EULA is terminated, you are responsible for and must uninstall the SOFTWARE from the DEVICE and delete any and

all accounts you may have established on DEVICE or are accessible through the SOFTWARE. You are solely responsible for maintaining the confidentiality of any accounts you have with SONY or third parties and any usernames and passwords associated with your use of the DEVICE.

Should you have any questions concerning this EULA, you may contact SONY by writing to SONY at: Sony Electronics Inc., 16535 Via Esprillo, San Diego, CA 92127.

Copyright 2020 Sony Electronics Inc. All rights reserved.