

VIA VENEZIA

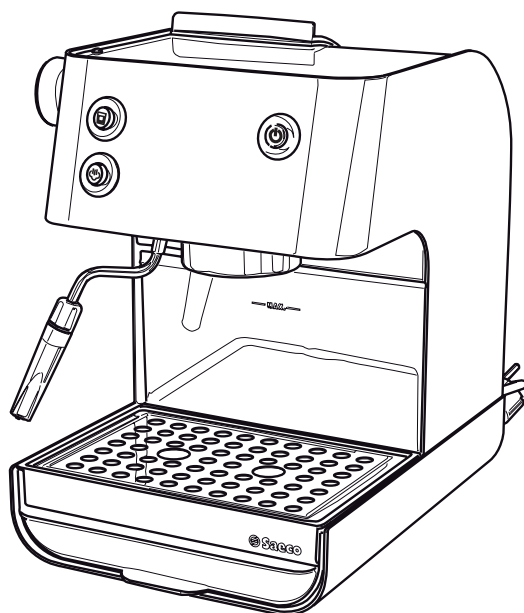

OPERATING INSTRUCTIONS
MODE D'EMPLOI
INSTRUCCIONES PARA EL USO



READ THESE OPERATING INSTRUCTIONS CAREFULLY BEFORE USING THE MACHINE.
LIRE ATTENTIVEMENT CES INSTRUCTIONS AVANT D'UTILISER LA MACHINE.
LÉANSE ATENTAMENTE LAS SIGUIENTES INSTRUCCIONES DE USO ANTES DE UTILIZAR LA MÁQUINA.

**FOR HOUSEHOLD USE ONLY
USAGE DOMESTIQUE SEULEMENT**

Ideas with Passion

Saeco

ENGLISH

IMPORTANT SAFEGUARDS

When using electrical appliances, basic safety precautions should always be followed to reduce the risk of fire, electric shock, and/or injury to persons, including the following:

1. Read all instructions and information in this instruction book and any other literature included in the carton referring to this product before operating or using this appliance.
2. Do not touch hot surfaces (i.e. steam wand, portafilter). Use handles or knobs.
3. To protect against fire, electric shock and personal injury, do not place cord, plugs or appliance in water or other liquid.
4. This appliance must be kept out of the reach of children.
5. Unplug from outlet when not in use and before cleaning.
6. Allow to cool before putting on or taking off parts, and before cleaning the appliance.
7. Do not remove the portafilter during brewing cycles as there is a danger of burns.
8. The use of accessory attachments not recommended by the appliance manufacturer may result in fire, electric shock, or personal injury.
9. Do not use outdoors.
10. Do not let cord hang over edge of table or counter, or touch hot surfaces.
11. Do not place on or near a hot gas or electric burner, or in a heated oven.
12. This machine was designed to process normal household quantities only. Not suitable for continuous operation or commercial use.
13. Do not operate any appliance with a damaged cord or plug, if the appliance malfunctions, or has been damaged in any manner. Return appliance to an authorized service facility for examination, repair, or adjustment.
14. Do not use if the water tank is not filled.
15. Always use cold water. Warm water or other liquids could cause damage to the appliance.
16. When plugging in the machine, always turn appliance "OFF", attach power cord to the machine first, then plug cord into wall outlet. To disconnect, always turn appliance "OFF", then remove plug from wall outlet.
17. Use extreme caution when using hot steam.
18. Do not use appliance for other than intended use.

SAVE THESE INSTRUCTIONS

• 2 •

SHORT CORD INSTRUCTION

A short power supply cord is provided to reduce the risk of tripping over or becoming entangled with a longer cord.

The cord should be accessible after installation of the machine in order to disconnect it at any moment if necessary.

Longer extension cords are available at retailers authorized to sell electrical accessories, and may be utilized if care is exercised in their use. If an extension cord is used:

- The marked electrical rating of the extension cord should be at least as great as the electrical rating of the appliance.
- If the appliance plug is grounded, the extension cord should be a 3-wire grounded extension cord.
- The longer cord should be arranged so that it will not drape over the countertop or tabletop, where it may be pulled on by children or accidentally tripped over.

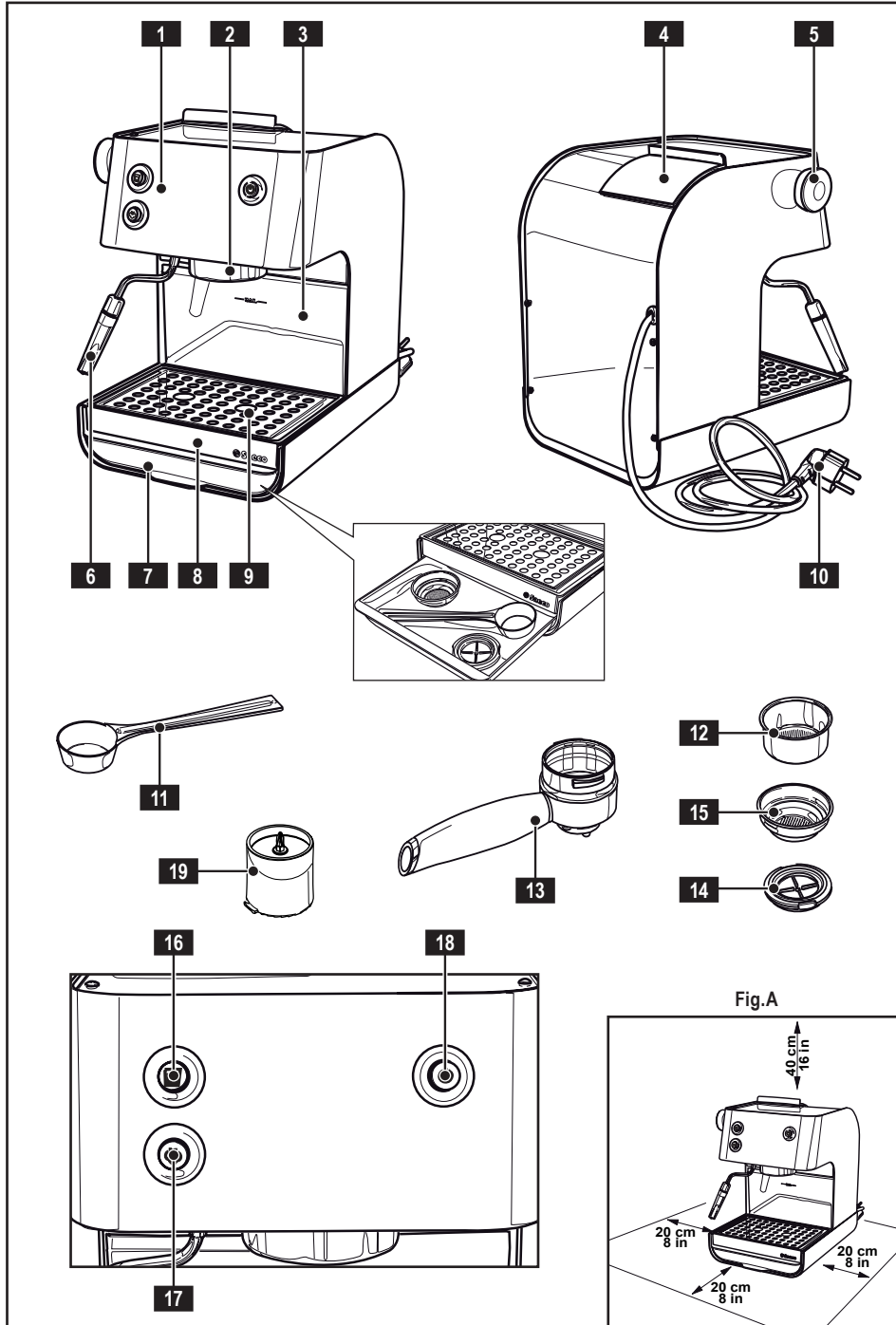

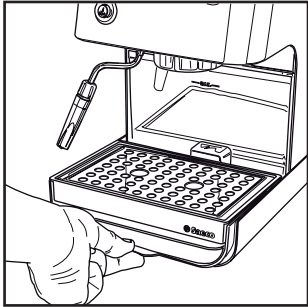

Fig.1

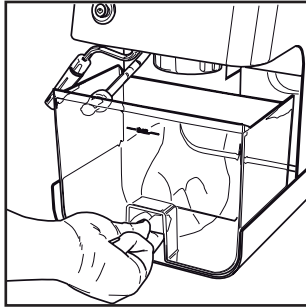

Fig.2

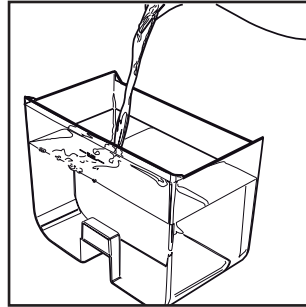

Fig.3

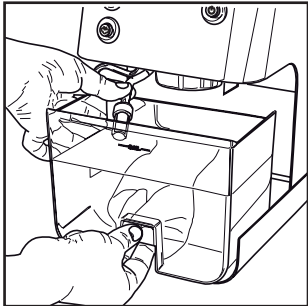

Fig.4

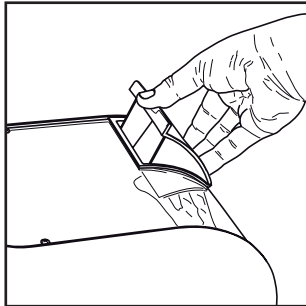

Fig.5

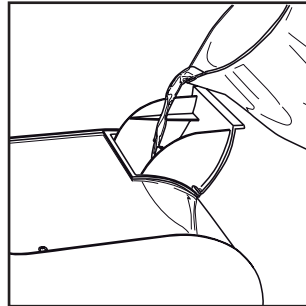

Fig.6

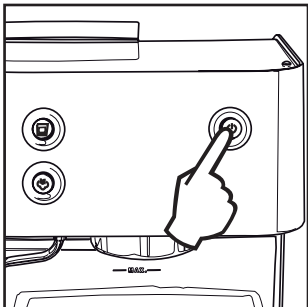

Fig.7

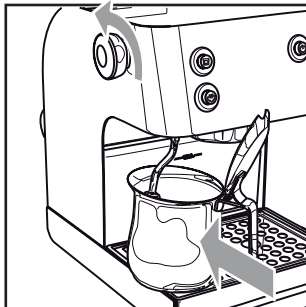

Fig.8

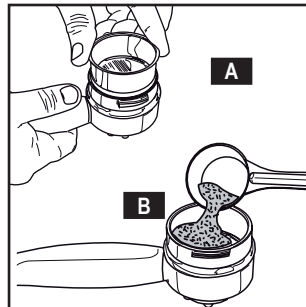

Fig.9

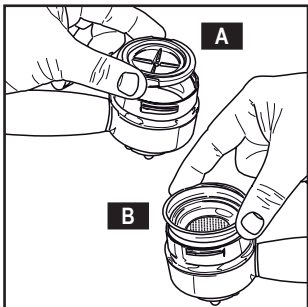

Fig.10

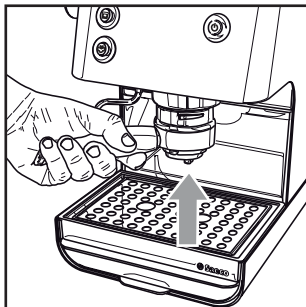

Fig.11

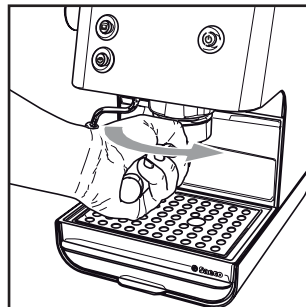

Fig.12

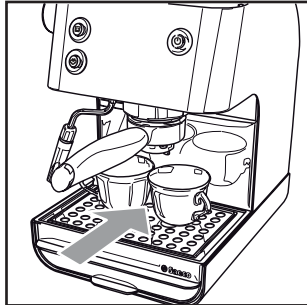

Fig.13

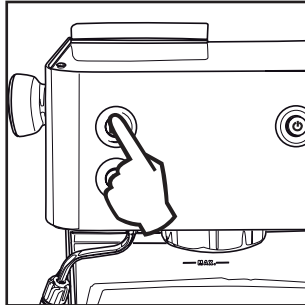

Fig.14



Fig.15

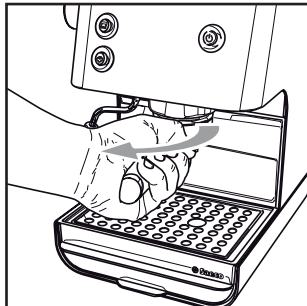

Fig.16

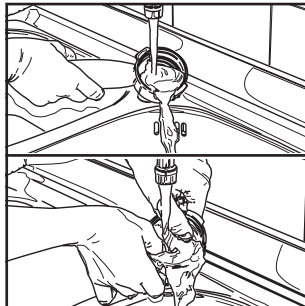

Fig.17

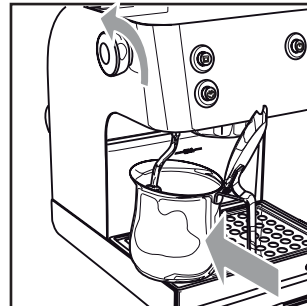

Fig.18

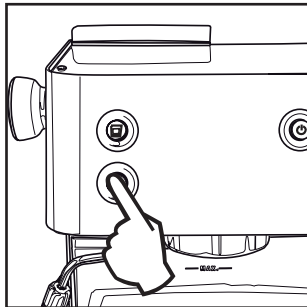

Fig.19

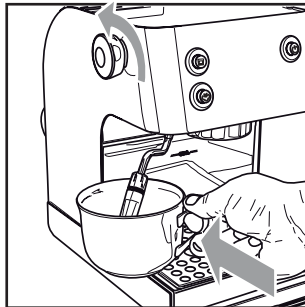

Fig.20

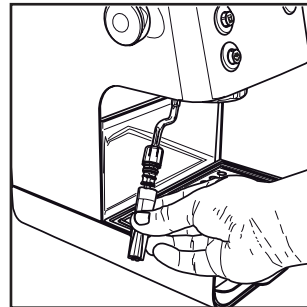

Fig.21

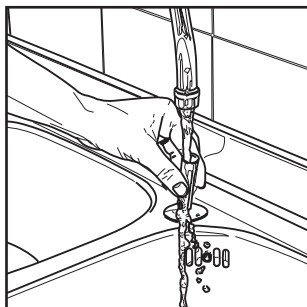

Fig.22

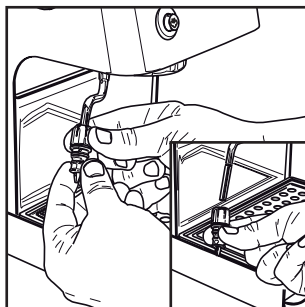

Fig.23

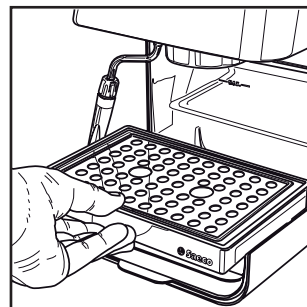



Fig.24

1 GENERAL INFORMATION



The coffee machine is made for brewing 1 or 2 cups of espresso coffee and features a swivel steam and hot water spout. The controls on the front of the machine are labeled with easy-to-read symbols. The machine has been designed for domestic use only and is not suitable for professional, continuous use.

 **Warning. No liability is assumed for any damage caused by:**

- **Incorrect use not in accordance with the intended uses;**
- **Repairs not carried out by authorized service centers;**
- **Tampering with the power cable;**
- **Tampering with any part of the machine;**
- **The use of non-original spare parts and accessories;**
- **Failure to descale the machine and storage at temperatures below 0°C.**

In these cases, the warranty is not valid.

1.1 To facilitate reading

  **A warning triangle draws the attention to all the instructions that are important for the user's safety. Please carefully follow these instructions to avoid serious injury!**

The reference to illustrations, parts of the appliance or controls, etc. is indicated by numbers or letters; in this case please refer to the illustration.

 **This symbol is used to highlight the information that is particularly important for ensuring optimal use of the machine.**

The illustrations corresponding to the text may be found on the inside cover. Keep this page open while reading the instructions.

1.2 How to use these operating instructions

Keep these operating instructions in a safe place and make them available to anyone else who may use the coffee machine. For further information or in case of problems, please refer to any authorized service center.

2 TECHNICAL DATA

The manufacturer reserves the right to make changes to the technical specifications of the product. The machine conforms to the European Directive 89/336/EEC (Italian Legislative Decree 476 dated 04/12/92) concerning electromagnetic compatibility.

Nominal Voltage - Power rating - Power supply
See label on the appliance

Housing material	Metal
Size (w x h x d)	220mm x 300mm x 270mm - 9" x 12" x 11"
Weight	4 kg - 9 lbs
Cable length	1.2 m - 47"
Control panel	Front
Filter holder	Pressurized portafilter
Pannarello	Plastic
Water tank (removable)	2 litres - 68 oz
Pump pressure	15 bar
Boiler	Stainless steel
Safety devices	Manual reset thermostat Thermofuse

3 SAFETY REGULATIONS



Never place live parts in contact with water: danger of short circuit! Steam and hot water may cause scalding! Do not direct the steam or hot water jet toward parts of the body; handle the steam/hot water spout with care: danger of scalding!

Intended use

The coffee machine is intended for domestic use only. Do not make any technical changes or use the machine for unlawful purposes since this would create serious hazards! The appliance is not for use by persons (included children) with reduced physical, mental or sensory abilities or with scarce experience and/or competences, unless they are under supervision of a person in charge of their safety or they are informed by him/her on the use of the appliance.

Power supply

Only connect the coffee machine to a suitable socket. The voltage must correspond to the indication on the machine's label.

ENGLISH

Power cable

Never use the coffee machine if the power cable is defective. If damaged, the power cable must be replaced by the manufacturer or its customer service department. Do not pass the cable around corners, over sharp edges or over hot objects and keep it away from oil.

Do not use the power cable to carry or pull the coffee machine. Do not pull out the plug by pulling on the power cable or touch it with wet hands.

Do not let the power cable hang freely from tables or shelves.

Protecting others

Prevent children from playing with the appliance. Children are not aware of the risks linked with electrical appliances. Do not leave the coffee machine packaging within the reach of children.

Danger of burning

Never direct the jet of hot steam and/or hot water towards yourself or others. Always use the handles or knobs provided.

Do not disconnect (remove) the portafilter during coffee brewing. Hot water drips may spill out from the coffee brew unit during the warming phase.

Location

Position the coffee machine in a safe place, where nobody may overturn it or be injured.

Hot water or steam may spill out: **danger of scalding!**

Do not keep the machine at a temperature below 0°C; freezing may damage the machine.

Do not use the coffee machine outdoors.

Do not place the machine on hot surfaces and close to open flames to prevent the housing from melting or being damaged.

Cleaning

Before cleaning the machine, deselect all buttons and then remove the plug from the socket.

Then wait for the machine to cool down. Never immerse the machine in water!

It is strictly forbidden to tamper with the inside of the machine.

Any water left in the tank for several days should not be consumed. Wash the tank and fill it with fresh drinking water.

Space for use and maintenance

To ensure that the coffee machine works properly and efficiently, the following conditions are recommended:

- Choose a level surface;
- Select a location that is sufficiently well-lit, clean and near an easily reachable socket;
- Allow for a minimum distance from the sides of the machine as shown in the illustration (Fig.A).

Storing the machine

If the machine is to remain out of use for a long time, turn it off and unplug it from the socket. Store it in a dry place

out of the reach of children. Keep it protected from dust and dirt.

Servicing / Maintenance

In case of failure, faults or a suspected fault after dropping, immediately remove the plug from the socket. Never attempt to operate a faulty machine. Servicing and repairs may only be carried out by authorized service center. All liability for damages caused by works not carried out in a professional manner is declined.

Fire safety

In case of fire, use Carbon Dioxide extinguishers (CO₂). Do not use water or dry-powder extinguishers.

Key to machine components (Pag.4)

- 1 Control panel
- 2 Brew unit
- 3 Water tank
- 4 Funnel for water tank filling
- 5 Hot water/steam knob
- 6 Steam/hot water wand (Pannarello)
- 7 Accessory drawer
- 8 Drip tray
- 9 Metal grill
- 10 Power cord
- 11 Ground coffee measuring scoop
- 12 Ground coffee filter holder
(one only for brewing 1 or 2 coffees)
- 13 Pressurized portafilter
- 14 Pod filter adapter
- 15 Pod filter
- 16 Brew button
- 17 Steam button
- 18 ON/OFF button
- 19 Scraper

4 INSTALLATION

For your own and for other people's safety, carefully follow the "Safety Regulations" in section 3.

4.1 Packaging

The original packaging has been designed to protect the machine during transport. We recommend keeping the packaging for future transport.

4.2 Installation instructions

Before installing the machine, read the following safety instructions carefully:

- Place the machine in a safe place;
- Make sure children cannot play with the machine;
- Do not place the machine on hot surfaces or near open flames.

The coffee machine is now ready to be connected to the power supply.

i Note: It is recommended to wash the parts before their first use and/or after they have not been used for a certain period of time.

4.3 Machine connection

! Electric current can be dangerous! It is therefore essential to follow the safety regulations carefully. Never use faulty cords! Faulty cords and plugs must be replaced immediately by authorized service centers.

The voltage of the appliance has been set by the manufacturer. Check that the voltage supplied matches the indications on the identification label on the bottom of the appliance.

- Check that the ON/OFF switch (18) is not pressed before connecting the machine to the power supply.
- Connect the plug to a wall socket with suitable voltage.

4.4 Water tank

- (Fig.1) - Remove the accessory drawer (7), the drip tray (8) and the grill (9).
- (Fig.2) - Remove the water tank (3). Be careful not to damage the water suction pipe.
- (Fig.3) - Rinse and fill it with fresh drinking water taking care not to overflow.
- (Fig.4) - Reinsert the tank into its seat. Take care to correctly replace the previously extracted pipe

! Only use fresh, non-sparkling drinking water to fill the tank. Hot water or any other liquid may damage the tank. Do not turn on the machine without water: make sure there is enough water in the tank.

i Note: For a quick water tank refill, the funnel placed in the upper part of the machine can be used. Open the funnel (Fig.5) and refill with water (Fig.6). After refilling, always close the funnel.

4.5 Priming the water circuit

Before starting up the machine, after long storage and when the water has been used up, the machine's water circuit must be primed.

- (Fig.7) - Press the ON/OFF switch (18). The inside light turns on.
- (Fig.8) - Place a container below the steam spout. Open the hot water/steam knob (5) by turning it counter-clockwise.
- Wait until a steady jet of water is emitted from the steam/hot water wand.
- Close the hot water/steam knob (5) by turning it clockwise. Remove the container.

The machine is now ready to brew coffee and dispense steam. Please see related sections for operating details.

5 COFFEE BREWING

! Caution! Do not remove the portafilter during the coffee brewing. Danger of burning.

- During this operation, the brew button light (16) may flash on and off; this operation should be considered normal and not as a fault.
- Before using the machine, make sure that the hot water/steam knob (5) is closed and that there is sufficient water in the tank.
- (Fig.7) - Press the ON/OFF button (18). The inside light turns on.
- Wait until the brew button light (16) turns on. The machine is now ready for coffee brewing.

5.1 Using ground coffee

- (Fig.9-A) - Insert the ground coffee filter (12) into the portafilter (13).
- (Fig.11) - Insert the portafilter in the brew unit from the bottom (2).
- (Fig.12) - Turn the portafilter from left to right until it locks in place. Release the grip from the portafilter. The handle slightly turns on the left. This movement guarantees the perfect operation of the portafilter.
- (Fig.14) - Preheat the portafilter by pressing the brew button (16). Water will spill out of the portafilter (this operation is only necessary for the first coffee).
- After 4 oz (50cc) of water has flowed out, press the brew button (16) again to stop hot water dispensing.
- (Fig.16) - Remove the portafilter from the machine by turning it to the left and pour out any water left. As the machine is fitted with the ground coffee filter (12), there is no need to change the filter to make one or two coffees.
- (Fig.9-B) - Add 1 or 2 level measuring scoops of ground coffee to the filter for one or two coffees; clean any coffee residues from the edge of the filter holder.
- (Fig.11) - Insert the portafilter (13) in the brew unit from the bottom (2).
- (Fig.12) - Turn the portafilter from left to right until it locks in place.
- (Fig.13) - Take 1 or 2 preheated cups and place them under the portafilter; check that they are correctly placed under the coffee dispensing holes.
- (Fig.14) - Press the brew button (16).
- When the desired quantity of coffee has been obtained, press the brew button again (16) to stop the coffee brewing and remove the cups of coffee (Fig.15).
- (Fig.16) - Wait a few seconds after brewing, then remove the portafilter and empty the remaining coffee grounds.

i Note: Keep the filter of the portafilter clean by removing it from its seat and washing with drinking water (Fig. 17).

ENGLISH

5.2 Coffee pods

- (Fig.9-A) - Remove the ground coffee filter (12) from the portafilter (13) by pulling it up.
- (Fig.10) - Insert the coffee pod adapter (14), with the curved part facing down, into the portafilter (13); then insert the pod filter (15).
- (Fig.11) - Insert the portafilter in the brew unit from the bottom (2).
- (Fig.12) - Turn the portafilter from left to right until it locks in place.
Release the grip from the portafilter. The handle is automatically turned slightly towards the left.
This movement assures the perfect functioning of the portafilter.
- (Fig.14) - Preheat the portafilter by pressing the brew button (16). Water will spill out of the portafilter (this operation is only necessary for the first coffee).
- After 4 oz. (50cc) of water has flowed out, press the brew button (16) again to stop hot water dispensing.
- (Fig.16) - Remove the portafilter from the machine by turning it from right to left and emptying out the remaining water.
- Insert the pod in the portafilter; make sure the paper from the pod does not overhang the portafilter.
- (Fig.11) - Insert the portafilter in the brew unit from the bottom (2).
- (Fig.12) - Turn the portafilter from left to right until it locks in place.
- Take **1 preheated cup** and place it under the portafilter; check that it is correctly placed under the coffee dispensing holes.
- (Fig.14) - Press the brew button (16).
- When the desired quantity of coffee has been obtained, press the brew button (16) again to stop coffee brewing and remove the cup of coffee.
- (Fig.16) - Wait a few seconds after dispensing, then remove the portafilter and dispose of the used pod.

i **Note: Keep the filter of the portafilter clean by removing it from its seat and washing with drinking water (Fig. 17).**

6 TIPS FOR CHOOSING COFFEE

As a general rule any type of coffee available on the market can be used. However, coffee is a natural product and its flavor changes according to its origin and blending. It is therefore a good idea to try different types, in order to find the most suited to your personal taste. For best results, we recommend using blends which are expressly indicated for espresso coffee machines. Coffee should always be dispensed by the portafilter without dripping. The speed of coffee dispensing can be modified by slightly changing the amount of coffee in the filter and/or using a different coffee grind.

! **BEFORE USING THE HOT WATER/STEAM WAND, MAKE SURE THAT THE WAND IS POSITIONED OVER THE DRIP TRAY.**

7 HOT WATER

! **Danger of scalding! At the beginning, short spurts of hot water may come out. The brewing spout can reach high temperatures: do not touch it with bare hands.**

- (Fig.7) - Press the ON/OFF button (18). The inside light turns on.
- Wait until the brew button light (16) turns up. The machine is now ready.
- (Fig.18) - Place a container or glass under the steam/hot water wand (Pannarello). Open the knob (5) by turning it counterclockwise.
- When the desired quantity of hot water has been dispensed, close the knob (5) by turning it clockwise.
- Remove the container with hot water.

8 STEAM / CAPPUCCINO

! **Danger of scalding! At the beginning, short spurts of hot water may come out. The brewing spout can reach high temperatures: do not touch it with bare hands.**

- (Fig.7) - Press the ON/OFF button (18). The inside light turns on.
- Wait until the brew button light (16) turns on.
- (Fig.19) - Press the steam button (17). The brew button light goes off (16).
- Wait for the steam button (17) and brew button (16) lights to turn on. Now the machine is ready to eject steam.
- (Fig.18) - Insert a container below the steam spout and open the knob (5) for a few seconds, so that remaining water exits from the steam/hot water wand (Pannarello); in a short time only steam will come out.
- Close the knob (5) and put the container away.
- Fill 1/3 of the container you wish to use to prepare the cappuccino with cold milk.

i **Use cold milk to get a better froth.**

- (Fig.20) - Immerse the steam wand in the milk and open the knob (5) by turning it counterclockwise; turn the milk container with slow upward movements so that it is warmed evenly.
- Close the knob (5); take the cup with the frothed milk.
- (Fig.19) - Press the steam button (17) again.
- Proceed with circuit priming as described in section 4.5 to make the machine ready for use.

i Note: The machine is ready when the brew button light (16) is permanently on.

i Note: If it is not possible to dispense a cappuccino as described, prime the circuit as explained in section 4.5 and then repeat the steps.

i The same process can be used to heat other beverages.

- After this operation, clean the steam wand with a wet cloth.

9 CLEANING

Maintenance and cleaning operations may only be carried out when the machine has cooled down and has been disconnected from the power supply.

- Do not immerse the machine in water or place any of its parts in a dishwasher.
- Do not use spirit, solvents and/or aggressive chemical agents.
- We recommend cleaning the water tank and filling it up with fresh water daily.
- (Fig.21-22) - Every day, after heating the milk, remove the external part of the Pannarello and wash it with fresh drinking water.
- (Fig.23) - The steam wand should be cleaned every week. In order to do this operation, you have to:
 - remove the external part of the Pannarello (for standard cleaning);
 - loosen the ring nut (without removing it);
 - remove the upper part of the Pannarello from the steam wand;
 - wash the upper part of the Pannarello with fresh drinking water;
 - wash the steam wand with a wet cloth and remove any milk residue;
 - replace the upper part of the steam wand (make sure it is completely inserted);
 - tighten the ring nut.
- Reassemble the external part of the Pannarello.
- (Fig.24) - Empty and clean the drip tray every day.
- Use a soft cloth damp cloth to clean the appliance.
- (Fig.17) - To clean the portafilter proceed as follows:
 - remove the filter, wash it thoroughly with hot water.
 - remove the adapter (if fitted), wash it thoroughly with hot water.
 - wash the internal part of the portafilter.
- Do not dry the machine and/or its components using a microwave and/or conventional oven.

Once descaling has been performed (see section 10), the brew unit filter and the gasket should be cleaned.

To clean the filter, proceed as follows:

- Loosen the screw fixing the filter to the brew unit by means of the screwdriver which is supplied with the scraper.

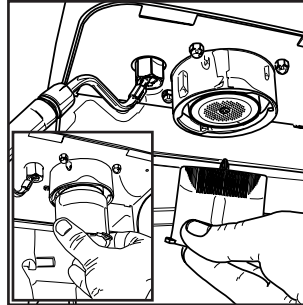

- Remove the filter and wash it thoroughly with a neutral detergent.

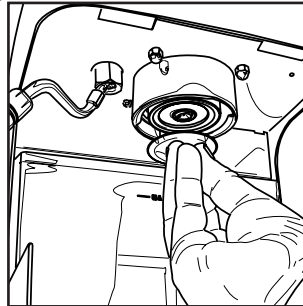

- Rinse and reinstall the filter; fasten the screw by means of the screwdriver which is supplied with the scraper.

To clean the gasket, proceed as follows:

- insert the scraper into the brew unit as shown;

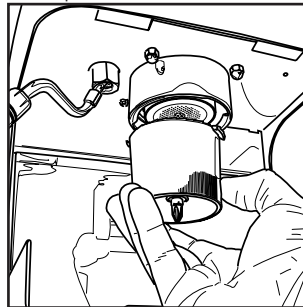

ENGLISH

- Gently turn the scraper to remove any coffee residues from the gasket;

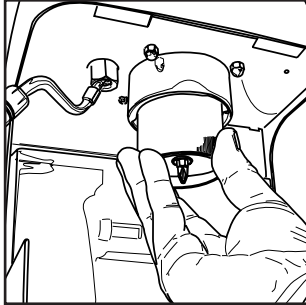

- Finally remove the scraper and clean with a wet cloth to eliminate any coffee traces.

10 DESCALING CYCLE

The formation of limescale inside the appliance is inevitable. It is necessary to descale the machine every 3-4 months of use and/or when you notice a reduction in the water capacity of the appliance.

i If you want to descale the machine yourself, you can use a non-toxic and/or non-harmful descaling product for coffee machines (commercially available). We recommend using Saeco descaling solution.



Caution! Do not use vinegar as a descaler.

- (Fig.2) - Remove and empty the water tank.
- (Fig.3) - Mix the descaling solution with water as specified on the pack of the descaling product and fill the water tank; insert the tank into the machine.
- (Fig.7) - Turn on the machine by pressing the ON/OFF button (18).
- (Fig.8) - Place a container below the steam spout.
- Open the knob (5) to remove, at intervals and one cup at a time, the whole descaling product. Close the knob (5) to stop the dispensing.
- (Fig.7) - During each interval allow the descaling solution to take effect for about 10-15 minutes, disconnecting the ON/OFF button (18). Empty the container.
- (Fig.2-3) - When the descaling solution is finished, remove the water tank, rinse it and fill it with fresh drinking water.
- (Fig.4; Fig.8) - Reinsert the tank in the machine. Open the knob (5) to empty 2/3 of the water. Close the steam knob (5) clockwise to stop dispensing.
- Let the machine warm up and empty the water tank as described above.

i If you are using a product other than the recommended one it is important to always

follow the manufacturer's instructions shown on the pack of the descaling product.

11 DISPOSAL

- Put unused appliances out of service.
- Disconnect the plug from the socket and cut the electrical cord.
- At the end of its life, take the appliance to a suitable waste collection site.

Fault	Possible cause	Solution
The machine does not turn on.	The machine is not connected to the power supply.	Connect the machine to the power supply.
The pump is very noisy.	No water in the tank.	Refill with water (section 4.4).
The coffee is too cold.	The brew button light (16) was off when the button was pressed.	Wait until the brew button light (16) turns on.
	The filter holder is not inserted for preheating (section 5).	Preheat the filter holder.
	Cold cups.	Preheat the cups with hot water.
The milk does not froth. It is not possible to prepare a cappuccino.	Milk is not suitable.	Use cold, whole milk.
	The steam wand is dirty.	Clean the steam wand as described in section 9.
	There is no more steam in the boiler.	Prime the circuit (section 4.5) and repeat the operations described in section 8.
The coffee is dispensed too fast, no crema builds up.	Too little coffee in the filter holder.	Add coffee (section 5).
	The grind is too coarse.	Use a different blend (section 6).
	Coffee is old or not suitable.	Use a different blend (section 6).
	Old or not suitable pod.	Change the pod.
Coffee does not come out or drips only.	No water.	Refill with water. (section 4.4).
	The grind is too fine.	Use a different blend (section 6).
	Coffee pressed in the filter holder.	Shake the ground coffee.
	Too much coffee in the filter holder.	Reduce the quantity of coffee in the filter holder.
	Knob (5) is open.	Close the knob (5).
	Calcified machine.	Descale the machine (section 10).
	The filter in the filter holder is clogged.	Clean the filter (section 9).
	Not suitable pod.	Change type of pod.
The coffee comes out from the side.	The filter holder is incorrectly inserted in the brew unit.	Insert the filter holder correctly (section 5).
	Upper edge of the filter holder is dirty.	Clean the rim of the filter holder.
	The gasket of the boiler is dirty or worn.	Clean or replace the gasket.
	Pod wrongly inserted.	Insert the pod correctly. Make sure it doesn't come out of the filter holder.
	Too much coffee in the filter holder.	Reduce the quantity of coffee by means of the measuring scoop.

Please contact an authorized service center for any faults not covered in the above table or when the suggested solutions do not solve the problem.

Limited Warranty & Descaling your Espresso Coffee Machine

Limited Warranty

This warranty covers all defects in workmanship or materials in the mechanical and electrical parts, arising under normal usage and care, in this Saeco USA product for a period of 1 (one) year from the date of purchase. A valid proof-of-purchase must be provided prior to any warranty service being rendered. A valid proof-of-purchase is an authorized retailer receipt specifying item, date purchased, and cost of item. An authorized retailer gift receipt with date of purchase and item is also an acceptable proof-of-purchase. Product is intended for household use only. Any commercial use voids the warranty. Exception: Royal machines are sold by Saeco USA for commercial use and will be covered by a 1 (one) year warranty on parts and labor both for household and commercial applications.

Who is covered?

The original purchaser or gift recipient who can provide proof-of-purchase from an authorized Saeco USA dealer.

What is not covered?

Improper usage and care can result in mineral buildup that damages the product. Saeco USA is not responsible for any expense resulting from such damage including transportation, shipping, and repairs resulting from mineral buildup, also known as calcium deposits, scale and lime scale.

What will be done?

During the applicable warranty period under normal household usage and care, Saeco USA will repair or replace, at their discretion, any mechanical or electrical part which proves defective, or replace product with a comparable model. The repaired or replacement product is warranted for one year from the original date of purchase or 90 days, whichever is greater.

How can you receive service?

Call 1-800-933-7876 to request service. A Return Authorization will be issued, when necessary. All warranty service must be performed by Saeco USA or an authorized Saeco USA Service Center or dealer. Please contact Saeco USA for details. Repair or attempted repair by unauthorized persons voids the warranty.

Unauthorized returned products will not be accepted and will be returned to sender at sender's expense.

In the event service is required:

- To obtain warranty service, a valid proof-of-purchase must be submitted to Saeco USA before returning product.

Maintain a copy of proof-of-purchase for your records.

- Return Authorization number issued by Saeco USA is necessary to obtain warranty service and must be clearly labeled on box.
- Saeco USA is not responsible for loss or damage during incoming shipment.
- Be sure to enclose any accessories or components related to the product's problem.
- Carefully package product. Saeco USA is not responsible for any transportation and shipping expense.
- Retain tracking information for your protection in case of loss or damage in shipment.

THIS LIMITED WARRANTY COVERS PRODUCTS PURCHASED AND USED WITHIN THE UNITED STATES AND DOES NOT COVER:

- Damages from improper installation.
- Damages in shipping.
- Defects other than manufacturing defects.
- Damages from misuse, abuse, accident, alteration, lack of proper care and maintenance, or incorrect current or voltage.
- Damage from service by other than a Saeco USA authorized dealer or service center. Contact Saeco USA for details.
- Any transportation and shipping charges.

Manufacturer makes no warranty, express or implied, including without limitation, any warranties of fitness or merchantability, except as expressly set forth above with respect to such products or parts therefor. Nor shall manufacturer have incurred any other obligations or liabilities on its part or be liable for any anticipated or lost profits, incidental damages, consequential damages, time charges, or any other losses incurred in connection with the purchase, installation, replacement, or repair of such products or any parts therefor whether original equipment or installed as a replacement covered by this warranty or otherwise; & manufacturer does not authorize any person to assume for manufacturer any other liability in connection with the products or parts therefor. Manufacturer assumes no liability for delay in performing its obligations hereunder if failure results, directly or indirectly, from any cause beyond its control, including but not limited to acts of god, acts of government, floods, fires, shortages of materials, strikes and other labor difficulties, or delays, or failures of transportation facilities. This warranty gives you specific legal rights, and you may also have other rights which vary from state to state.

DESCALING YOUR ESPRESSO COFFEE MACHINE

As part of normal preventative maintenance, espresso makers should be descaled approx. every 2-3 months, depending on the volume of use and hardness of your local water supply.

WARNINGS

Do not swallow. Avoid eye contact. Wash hands after use. Do not expose to heat.

- Keep out of reach of children.
- This product is non-toxic.

To descale your espresso coffee machine, please follow these steps:

MANUAL FILTER HOLDER MACHINES (ie: VIA VENEZIA, GRAN CREMA, AROMA, MAGIC CAPPUCCINO, SIRENA):

1. Fill the water tank with the descaling solution. (1 packet of Saeco descaling solution to one full tank of water.)
2. Turn on the machine and remove filter holder.
3. Run approximately 8 oz. of solution through the brew head. Turn machine off and let the machine sit for 15 minutes.
4. Run approximately 8 oz. through the steam wand, and again, turn machine off and let sit for 15 minutes.
5. Repeat this procedure, alternating between the brew head and steam wand until the water tank is empty. Then rinse water tank thoroughly and run two tanks of clear water through the machine, alternating between the brew head and steam wand.

Should be bold, just like other headers.

1. Fill the water tank with the descaling solution. (1 packet of Saeco descaling solution to 4 cups of water.)
2. Turn on the machine.
3. Run approximately 8 oz. through the steam wand, turn machine off and let sit for 15 minutes.
4. Repeat this procedure until the water tank is empty. Then rinse water tank thoroughly and flush the machine by running two tanks of clear water through the steam wand.

PRIMEA / TALEA / ODEA / INCANTO / MAGIC / ROYAL / V'ESPRESSO AUTOMATIC MACHINES:

1. Fill the water tank with the descaling solution. (1 packet of Saeco descaling solution to 4 cups of water.)
2. Follow automatic descaling instructions as described in manual.

This procedure, when performed as necessary, should help avoid any major descaling requirements and related expenses.

We always recommend the use of bottled or filtered water to extend the longevity of your espresso machine. Distilled water should not be used, as too many of the necessary minerals are missing to make a good tasting espresso.

To cancel the descale message upon completion of the descaling cycle:

- Primea, Talea, Odea, Incanto or V'spresso: See individual

machine manuals.

- Magic Deluxe or Royal Digital: Press and hold the steam button for 5-10 seconds.
- Royal Exclusive or Royal Professional: Enter programming mode by pressing and holding the ENT (preground) button. Scroll to the sub-menu 'Sign.Descal'. Press the enter button, scroll to yes, press the enter button. Scroll to the 'Exit' sub-menu and press enter.

There are many good descaling agents on the market today including Saeco's own product: Part number 524000, 3 packets, MSRP \$7.00 plus \$5.90 shipping & handling. Any descaling product used for our machines should be citric based. Do not use vinegar or lemon juice as this will cause damage to the machine.

This product is non-toxic, biodegradable & odorless. FIRST AID: If ingested, drink 2-3 glasses of water. In case of eye contact, flush thoroughly with cool running water for 15 minutes. Remove any contact lenses. Contact physician in either case, then get prompt medical attention. For skin contact, flush with water.

If you have any questions or comments, please call

Customer Service 1-800-933-7876

or visit: www.saecooutlet.com

**UNITED STATES SERVICE CENTER LISTING - LISTE DES CENTRES
D'ASSISTANCE - LISTA DE CENTROS DE ASISTENCIA**

State Pays Estado	City Ville Ciudad	Service Center Centre d'assistance Centro de asistencia	Telephone Numéro de téléphone Teléfono
AZ	Phoenix	Kitchen Classics/Kitchen Store	602-954-8141
CA	Burlingame	Espresso Equip Engineering LLC	650-375-8480
CA	Escondido	Mart's Appliance Service	760-745-7711
CA	Gardena	A Latte Hotte	310-294-9744
CA	San Jose	Appliance Repair Express	408-371-8853
CA	Signal Hill	Swiss Systems, Inc.	310-689-2372
CA	Woodland Hills	Speedy Appliance Service	818-225-7774
CO	Colorado Springs	Maric Beverage Systems	719-380-1610
FL	Boca Raton	SmArt Deco	561-620-0287
FL	Sarasota	Beanz, Inc. (The Beanz Man)	941-359-8916
IL	Bensenville	The Espresso Shoppe	630-350-0066
IL	Chicago	Longo & Siefer, Inc. (Coffee Exchange)	773-745-9295
IN	Indianapolis	Pro Tech Beverage Service	317-271-8515
MA	Everett	TC's Repair Service, Inc.	800-381-5001
MI	Utica (Shelby Township)	Espresso Machine Experts MI	586-739-9500
MN	Minneapolis	Kitchen Window / Alternative Con	612-824-4417
NC	Cornelius	The Coffeeboss, LLC	704-987-3310
NC	Wilmington	Personal Systems, Ltd	877-286-2833
NJ	Berkeley Heights	The Repair Shack	908-464-0797
NJ	Somerville	Butensky Services Co.	908-707-0912
NY	Bronx	Cerini Coffee Services Inc	718-584-6120
NY	Brooklyn	Solomon's Appliance Center	718-236-5065
NY	Mount Kisco	Encrybe, Inc. (The Java Fix)	914-514-8042
OH	Rocky River	River Espresso	216-544-4954
OR	Elmira	Stefano's Espresso Care	541-935-1212
OR	Medford	Cafe West Distribution	877-701-2020
PA	Bethel Park	Espresso D'Milan, LLC	412-663-0125
PA	Lansdale	Services Unlimited, Inc.	215-361-7000
SC	Myrtle Beach	Coffee Joe's Repair	843-293-2886
TX	Richardson	Espresso RMI, Inc.	972-690-6969
UT	Salt Lake City	Rimini Coffee / Shea Service	801-539-1210
WA	Seattle	Home Espresso Repair Service	206-789-9513
WA	Spokane	Tech One Services	509-536-0524
WA	Vancouver	Espresso Resource NW	503-251-2970

**CANADA SERVICE CENTER LISTING - LISTE DES CENTRES D'ASSISTANCE -
LISTA DE CENTROS DE ASISTENCIA**

State Pays Estado	City Ville Ciudad	Service Center Centre d'assistance Centro de asistencia	Telephone Numéro de téléphone Teléfono
Quebec	Montreal	Saeco Canada ltée	514-385-5551
Quebec	Québec	Importation Mi-Ra	418-682-3878
Quebec	Ste-Foy	Café en grains	418-653-6265
Quebec	Québec	Importation Nuava	418-649-7858
Quebec	Montreal	Centre du Rasoir Fairview Pointe Claire	514-697-6343
Quebec	Montreal	Centre du Rasoir fine Lame Carré Phillips	514-842-2921
Quebec	Baie Comeau	Centre du Rasoir Centre Comm. Manicouagan	418-295-2161
Quebec	Québec	Centre du Rasoir Galerie de la Capitale	418-627-2378
Quebec	Repentigny	Centre du Rasoir Fine Lame Rive Nord	450-585-9895
Quebec	Rimouski	Centre du Rasoir Carrefour Rimouski	418-722-0419
Quebec	Shawinigan	Centre du Rasoir Fine Lame Plaza de la Mauricie	819-539-4382
Quebec	Sherbrooke	Centre du Rasoir Carrefour de L'Estrie	819-346-8979
Quebec	St.Jean sur le Richelieu	Centre du Rasoir Carrefour Richelieu	450-349-1605
Quebec	Ste-Foy	Centre du Rasoir Place Ste-Foy	418-653-1710
Quebec	Ville d'Anjou	Centre du Rasoir Galeries d'Anjou	514-493-0922
Quebec	Drummondville	Boutik Elektrik / Drummondville	819-472-4244
Quebec	Gatineau	Boutik Elektrik / Promenades de l'Outaouais	819-246-8400
Quebec	Hull	Boutik Elektrik / Galeries de Hull	819-771-2434
Quebec	Rivière-du-Loup	Boutik Elektrik / Centre Commerciale Rivière-du-Loup	418-867-8508
Quebec	Rosemère	Boutik Elektrik Place Rosemère	450-437-9178
Quebec	Rouyn-Noranda	Boutik Elektrik	819-762-1152
Quebec	Sherbrooke	Boutik Elektrik Galeries Quatres Saisons	819-820-7890
Quebec	St-Antoine des Laurentides	Boutik Elektrik Galeries de Laurentides	418-277-2884
Quebec	Trois-Rivières	Boutik Elektrik	819-691-4125
Quebec	Trois-Rivières	Boutik Elektrik Centre Commercial Les Rivières	819-374-2545
Quebec	Victoriaville	Boutik Elektrik Carrefour des Bois Francs	819-751-2321
Ontario	Toronto	Saeco Ontario Ltd.	416-256-9191
Ontario	London	Personal Edge / White Oaks Mall	519-681-0990
Ontario	Hamilton	Personal Edge / Lime Ridge Mall	905-318-6023
Ontario	Kitchener	Personal Edge / Fairview Park Mall	519-895-1328
Ontario	Carlingwood	Personal Edge / Carlingwood	613-725-0173
Ontario	Kingston	Personal Edge / Cataraqui Town Center)	613-634-9605
Ontario	London	Personal Edge / Masonville Place	519-672-7894
Ontario	Oshawa	Personal Edge	905-728-3503

**CANADA SERVICE CENTER LISTING - LISTE DES CENTRES D'ASSISTANCE -
LISTA DE CENTROS DE ASISTENCIA**

State Pays Estado	City Ville Ciudad	Service Center Centre d'assistance Centro de asistencia	Telephone Numéro de téléphone Teléfono
Ontario	Thornhill	Personal Edge	905-764-7190
British Columbia	Vancouver	Saeco West Ltd	604-299-7555
British Columbia	Kelowna	Pioneer Coffee	250-861-3308
British Columbia	Victoria	ABC Electric	250-382-7221
Alberta	Calgary	Espuccino	403-263-3224
Alberta	Calgary	National Cappuccino	403-571-8555
Alberta	Edmonton	Bilotta Food Equipment & Commercial Cappuccino Co. LTD	800-475-4656
Manitoba	Winnipeg	DeLuca Foods	204-775-8605
Nova Scotia	Halifax	Walkers Electronic	902-454-0291
Saskatchewan	Saskatoon	Bosch/Miele Kitchen Center	306-242-3744

Customer Service 1-800-933-7876
or visit: www.saecoutlet.com

Type Sin006XN

Cod. 15001163 Rev.00 15-05-07



Saeco International Group S.p.A. Via Torretta, 240 - 40041 Gaggio Montano
Bologna - Italy - Tel. +39 0534.771.111 - Fax. +39 0534.31025
<http://www.saeco.com>