

INSTALLATION INSTRUCTIONS

T-Class™ TSA*S4 Units G, J and Y Voltages

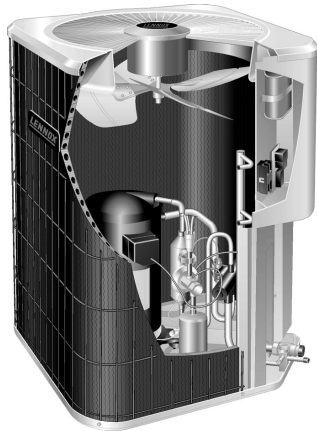

RETAIN THESE INSTRUCTIONS FOR FUTURE REFERENCE

These instructions are intended as a general guide and do not supersede local codes in any way. Consult authorities having jurisdiction before installation.

⚠ WARNING

Improper installation, adjustment, alteration, service or maintenance can cause personal injury, loss of life, or damage to property.

Installation and service must be performed by a licensed professional installer (or equivalent) or a service agency.

⚠ IMPORTANT

The Clean Air Act of 1990 bans the intentional venting of refrigerant (CFCs, HCFCs AND HFCs) as of July 1, 1992. Approved methods of recovery, recycling or reclaiming must be followed. Fines and/or incarceration may be levied for noncompliance.

⚠ IMPORTANT

This unit must be matched with an indoor coil as specified in Engineering Handbook. Coils previously charged with HCFC-22 must be flushed.

NOTICE TO INSTALLER

UNIT PLACEMENT

It is critical for proper unit operation to place outdoor unit on an elevated surface as described in *Unit Placement* section on page 6.

BRAZING LINE SET TO SERVICE VALVES

It is imperative to follow the brazing technique illustrated starting on page 9 to avoid damaging the service valve's internal seals.

AIR CONDITIONER
507993-01
7/19

TABLE OF CONTENTS

Shipping and Packing List	1
General	1
Unit Dimensions	2
Typical Unit Parts Arrangement	2
Model Number Identification	3
Operating Gauge Set and Service Valves	3
Recovering Refrigerant from Existing System	5
New Outdoor Unit Placement	6
New or Replacement Line Set	6
Brazing Connections	9
Flushing Line Set and Indoor Coil	12
Installing Indoor Metering Device	13
Leak Test Line Set and Indoor Coil	14
Evacuating Line Set and Indoor Coil	15
Electrical Connections	16
Servicing Unit Delivered Void of Charge	18
Start-Up	18
System Refrigerant	18
System Operation	22
Maintenance	22
Start-Up and Performance Checklist	24

Shipping and Packing List

Check the unit for shipping damage and listed times below are intact. If damaged, or if parts are missing, immediately contact the last shipping carrier.

- 1 — Assembled outdoor unit
- 1 — Liquid line filter drier

General

TSA*S4 Air Conditioners, which will also be referred to in this instruction as the outdoor unit, uses HFC-410A refrigerant. This outdoor unit must be installed with a matching indoor unit and line set as outlined in the *TSA*S4 Engineering Handbook*.

This outdoor unit is designed for use in thermal expansion valve (TXV) systems only.



Unit Dimensions - inches (mm)

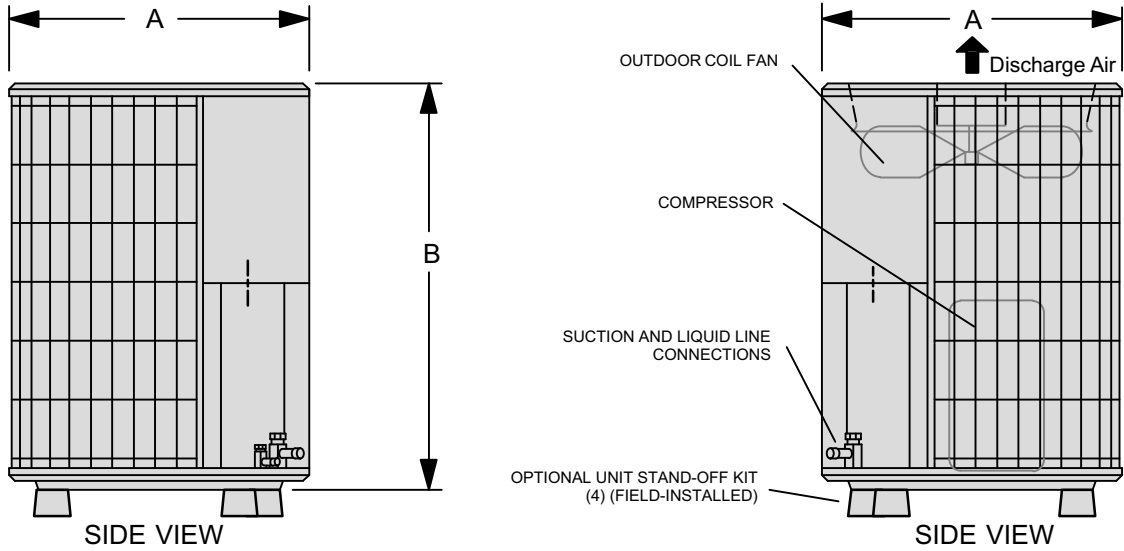

Model Number	A	B
TSA036S4N4	24-1/4 (616)	29-1/4 (743)
TSA042S4N4	28-1/4 (724)	29-1/4 (743)
TSA048S4N4	28-1/4 (724)	37-1/4 (925)
TSA060S4N4	28-1/4 (724)	33-1/4 (845)

Typical Unit Parts Arrangement

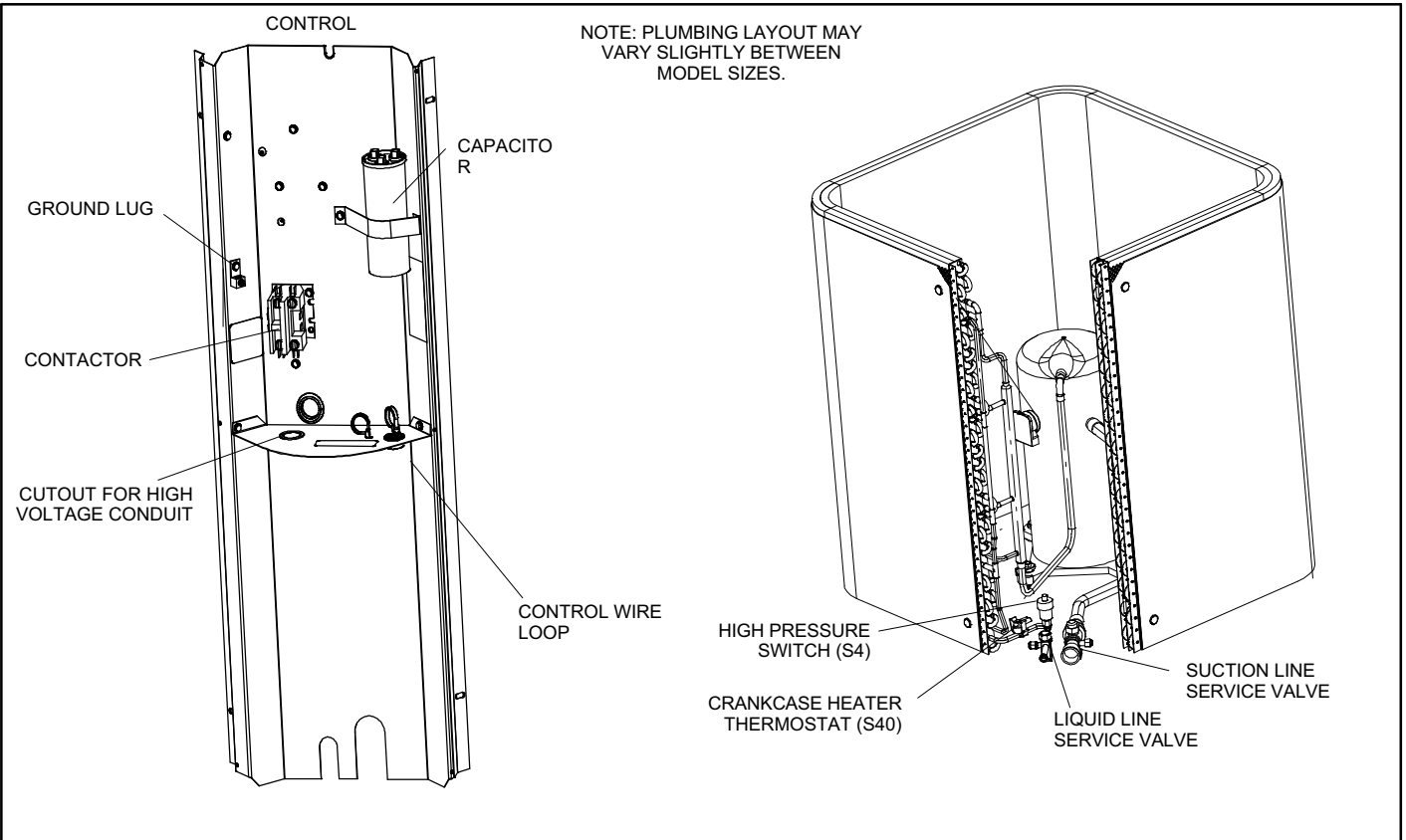
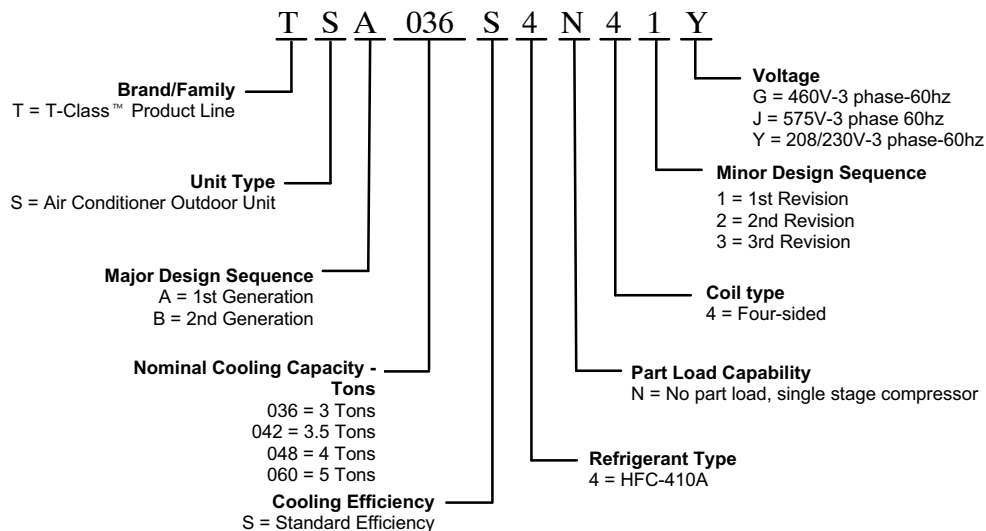

Figure 1. Typical Unit Parts Arrangement

Model Number Identification



⚠ CAUTION

Physical contact with metal edges and corners while applying excessive force or rapid motion can result in personal injury. Be aware of, and use caution when working near these areas during installation or while servicing this equipment.

Operating Gauge Set and Service Valves

These instructions are intended as a general guide and do not supersede local codes in any way. Consult authorities who have jurisdiction before installation.

TORQUE REQUIREMENTS

When servicing or repairing heating, ventilating, and air conditioning components, ensure the fasteners are appropriately tightened. Table 1 lists torque values for fasteners.

⚠ IMPORTANT

Only use Allen wrenches of sufficient hardness (50Rc - Rockwell Harness Scale minimum). Fully insert the wrench into the valve stem recess.

Service valve stems are factory-torqued (from 9 ft-lbs for small valves, to 25 ft-lbs for large valves) to prevent refrigerant loss during shipping and handling. Using an Allen wrench rated at less than 50Rc risks rounding or breaking off the wrench, or stripping the valve stem recess.

⚠ IMPORTANT

To prevent stripping of the various caps used, the appropriately sized wrench should be used and fitted snugly over the cap before tightening.

When servicing or repairing HVAC components, ensure caps and fasteners are appropriately tightened. Table 1 lists torque values for typical service and repair items.

Table 1. Torque Requirements

Parts	Recommended Torque	
Service valve cap	8 ft.- lb.	11 NM
Sheet metal screws	16 in.- lb.	2 NM
Machine screws #10	28 in.- lb.	3 NM
Compressor bolts	90 in.- lb.	10 NM
Gauge port seal cap	8 ft.- lb.	11 NM

USING MANIFOLD GAUGE SETS

When checking the system charge, use a manifold gauge set that features low-loss anti-blow back fittings. See figure 17 for a typical manifold gauge connection setup.

Manifold gauge sets used with HFC-410A refrigerant systems must be capable of handling the higher system operating pressures. The gauges should be rated for use with pressures of 0 - 800 on the high side and a low side of 30" vacuum to 250 psi with dampened speed to 500 psi. Gauge hoses must be rated for use at up to 800 psi of pressure with a 4000 psi burst rating.

OPERATING SERVICE VALVES

The liquid and suction line service valves are typically used for removing refrigerant, flushing, leak testing, evacuating, checking charge and charging.

Each valve is equipped with a service port which has a factory-installed valve stem. Figure 2 provides information on how to access and operating both angle and ball service valves.

Operating Angle Type Service Valve:

1. Remove stem cap with an appropriately sized wrench.
2. Use a service wrench with a hex-head extension (3/16" for liquid line valve sizes and 5/16" for vapor line valve sizes) to back the stem out counterclockwise as far as it will go.

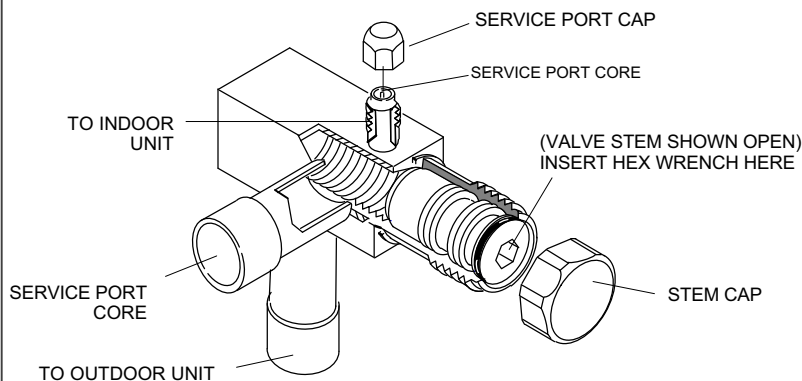

**ANGLE-TYPE SERVICE VALVE
(BACK-SEATED OPENED)**

When service valve is **OPEN**, the service port is open to line set, indoor and outdoor unit.

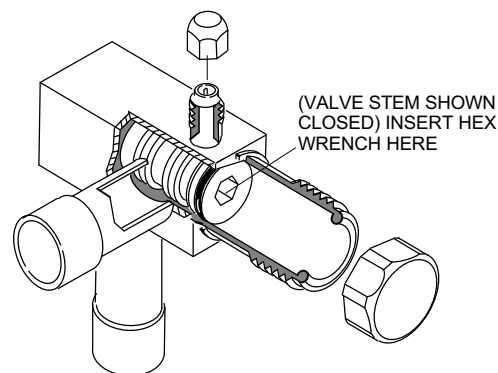

**ANGLE-TYPE SERVICE VALVE
(FRONT-SEATED CLOSED)**

WHEN SERVICE VALVE IS **CLOSED**, THE SERVICE PORT IS OPEN TO THE LINE SET AND INDOOR UNIT.

Operating Ball Type Service Valve:

1. Remove stem cap with an appropriately sized wrench.
2. Use an appropriately sized wrench to open. To open valve, rotate stem counterclockwise 90°. To close rotate stem clockwise 90°.

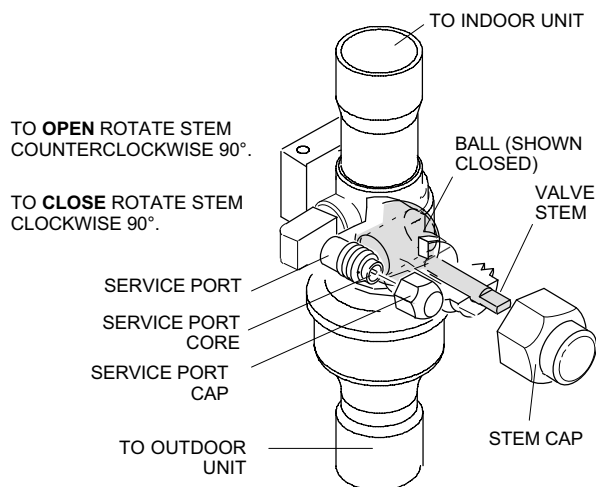

To Access Service Port:

A service port cap protects the service port core from contamination and serves as the primary leak seal.

1. Remove service port cap with an appropriately sized wrench.
2. Connect gauge set to service port.
3. When testing is completed, replace service port cap and tighten as follows:

- With torque wrench: Finger tighten and torque cap per table 1.
- Without torque wrench: Finger tighten and use an appropriately sized wrench to turn an additional 1/6 turn clockwise.

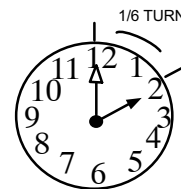

Reinstall Stem Cap:

Stem cap protects the valve stem from damage and serves as the primary seal. Replace the stem cap and tighten as follows:

- With Torque Wrench: Finger tighten and then torque cap per table 1.
- Without Torque Wrench: Finger tighten and use an appropriately sized wrench to turn an additional 1/12 turn clockwise.

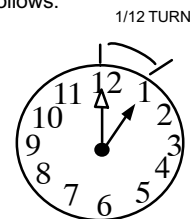

NOTE — A label with specific torque requirements may be affixed to the stem cap. If the label is present, use the specified torque.

Figure 2. Angle and Ball Service Valves

RECOVERING

REFRIGERANT FROM SYSTEM

1 DISCONNECT POWER

Disconnect all power to the existing outdoor unit at the service disconnect switch or main fuse box/breaker panel.

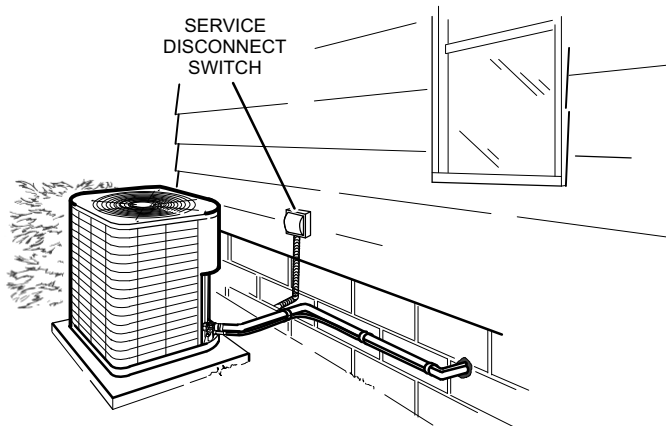

2 CONNECT MANIFOLD GAUGE SET

Connect a gauge set, clean recovery cylinder and a recovery machine to the service ports of the existing unit. Use the instructions provided with the recovery machine to make the connections.

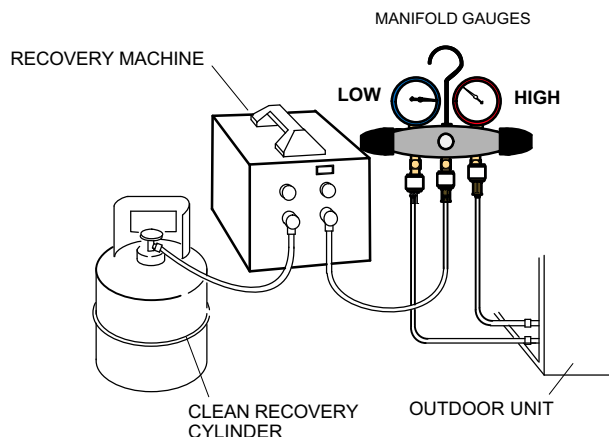

3 RECOVERING REFRIGERANT

Remove existing refrigerant using one of the following procedures:

IMPORTANT — Some system configurations may contain higher than normal refrigerant charge due to either large internal coil volumes, and/or long line sets.

METHOD 1:

Use this method if the existing outdoor unit is not equipped with shut-off valves, or if the unit is not operational and you plan to use the existing to flush the system.

Remove all refrigerant from the existing system. Check gauges after shutdown to confirm that the entire system is completely void of refrigerant.

METHOD 2:

Use this method if the existing outdoor unit is equipped with manual shut-off valves, and you plan to use new refrigerant to flush the system.

The following devices could prevent full system charge recovery into the outdoor unit:

- Outdoor unit's high or low-pressure switches (if applicable) when tripped can cycle the compressor **OFF**.
- Compressor can stop pumping due to tripped internal pressure relief valve.
- Compressor has internal vacuum protection that is designed to unload the scrolls (compressor stops pumping) when the pressure ratio meets a certain value or when the suction pressure is as high as 20 psig. (Compressor suction pressures should never be allowed to go into a vacuum. Prolonged operation at low suction pressures will result in overheating of the scrolls and permanent damage to the scroll tips, drive bearings and internal seals.)

Once the compressor can not pump down to a lower pressure due to one of the above system conditions, shut off the vapor valve. Turn OFF the main power to unit and use a recovery machine to recover any refrigerant left in the indoor coil and line set.

Perform the following task:

- A Start the existing system in the cooling mode and close the liquid line valve.
- B Use the compressor to pump as much of the existing HCFC-22 refrigerant into the outdoor unit until the outdoor system is full. Turn the outdoor unit main power OFF and use a recovery machine to remove the remaining refrigerant from the system.

NOTE — It may be necessary to bypass the low pressure switches (if equipped) to ensure complete refrigerant evacuation.

- C When the low side system pressures reach 0 psig, close the vapor line valve.
- D Check gauges after shutdown to confirm that the valves are not allowing refrigerant to flow back into the low side of the system.

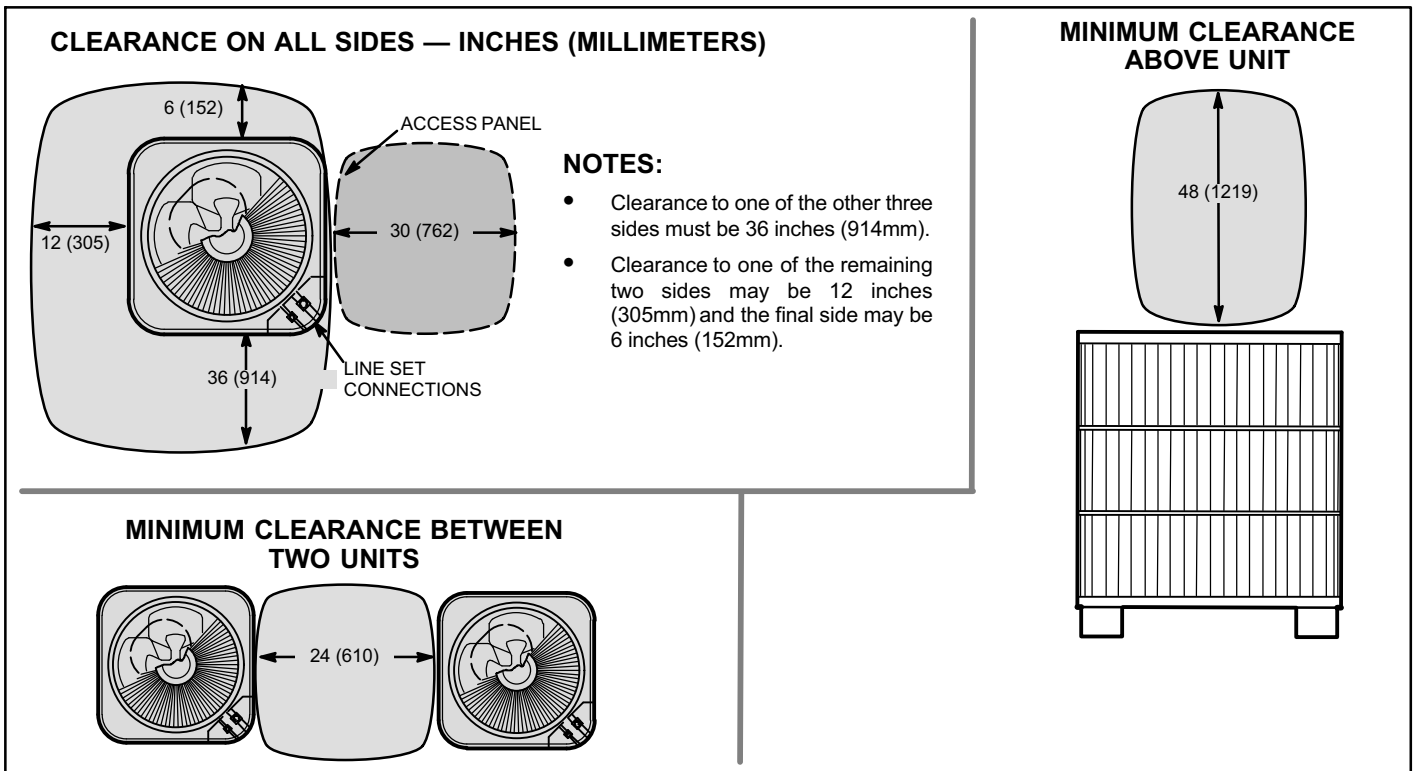

Figure 3. Installation Clearances

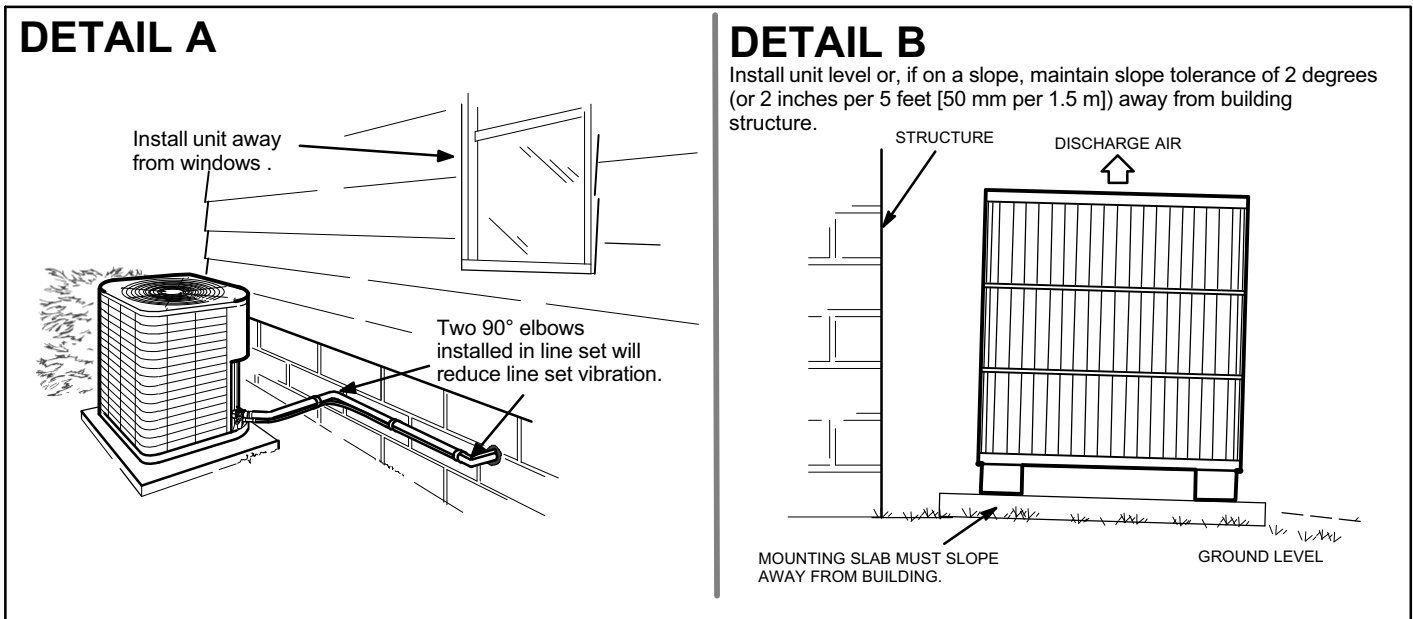

Figure 4. Placement, and Slab Mounting

New Outdoor Unit Placement

See *Unit Dimensions* on page 2 for sizing mounting slab, platforms or supports. Refer to figure 3 for mandatory installation clearance requirements.

POSITIONING CONSIDERATIONS

⚠ CAUTION
 In order to avoid injury, take proper precaution when lifting heavy objects.

Consider the following when positioning the unit:

- Some localities are adopting sound ordinances based on the unit's sound level registered from the adjacent property, not from the installation property. Install the unit as far as possible from the property line.
- When possible, do not install the unit directly outside a window. Glass has a very high level of sound transmission. For proper placement of unit in relation to a window see the provided illustration in figure 4.

PLACING OUTDOOR UNIT ON SLAB

When installing a unit at grade level, the top of the slab should be high enough above the grade so that water from higher ground would not collect around the unit as illustrated in figure 4.

Slab may be level or have a slope tolerance away from the building of not more than two degrees, or 2 inches per 5 feet (51 mm per 1524 mm) as illustrated in figure 4.

INSTALLING OUTDOOR UNIT ON ROOF

Install the unit at a minimum of 4 inches (102 mm) above the surface of the roof. Ensure the weight of the unit is properly distributed over roof joists and rafters. Redwood or steel supports are recommended.

New or Replacement Line Set

This section provides information on installation or replacement of existing line set. If line set is not being installed or replaced then proceed to *Brazing Connections* on page 9.

If refrigerant lines are routed through a wall, seal and isolate the opening so vibration is not transmitted to the building. Pay close attention to line set isolation during installation of any HVAC system. When properly isolated from building structures (walls, ceilings, floors), the refrigerant lines will not create unnecessary vibration and subsequent sounds.

Also, consider the following when placing and installing a high-efficiency air conditioner:

REFRIGERANT LINE SET

Field refrigerant line set consists of liquid and suction lines from the outdoor unit to the indoor unit coil. Use Lennox L15 (braze, non-flare) series line set, or field-fabricated refrigerant lines that meet the specifications listed below.

NOTE - When installing refrigerant lines longer than 50 feet, contact Lennox Technical Support Product Applications for assistance or Lennox piping manual. To obtain the correct information from Lennox, be sure to communicate the following points:

- Model (TSA*S4) and size of unit (e.g. -060).
- Line set diameters for the unit being installed as listed in table 2 and total length of installation.
- Number of elbows and if there is a rise or drop of the piping.

⚠ IMPORTANT

Mineral oils are not compatible with HFC-410A. If oil must be added, it must be a Polyol ester oil.

The compressor is charged with sufficient Polyol ester oil for line set lengths up to 50 feet. Recommend adding oil to system based on the amount of refrigerant charge in the system. No need to add oil in system with 20 pounds of refrigerant or less. For systems over 20 pounds - add one ounce of every five pounds of refrigerant.

Recommended topping-off POE oils are Mobil EAL ARCTIC 22 CC or ICI EMKARATE™ RL32CF.

MATCHING WITH NEW OR EXISTING INDOOR COIL AND LINE SET

The RFC1-metering line consisted of a small bore copper line that ran from condenser to evaporator coil. Refrigerant was metered into the evaporator by utilizing temperature/pressure evaporation effects on refrigerant in the small RFC line. The length and bore of the RFC line corresponded to the size of cooling unit.

If the TSA*S4 is being used with either a new or existing indoor coil which is equipped with a liquid line which served as a metering device (RFCI), the liquid line must be replaced prior to the installation of the TSA*S4 unit. Typically a liquid line used to meter flow is 1/4" in diameter and copper.

LIQUID LINE FILTER DRIER INSTALLATION

The filter drier (one is shipped with each TSA*S4 unit) must be field installed in the liquid line between the outdoor unit's liquid line service valve and the indoor coil's metering device TXV as illustrated in figure 5. This filter drier must be installed to ensure a clean, moisture-free system. Failure to install the filter drier will void the warranty. A replacement filter drier is available from Lennox. See *Brazing Connections* on page 9 for special procedures on brazing filter drier connections to the liquid line.

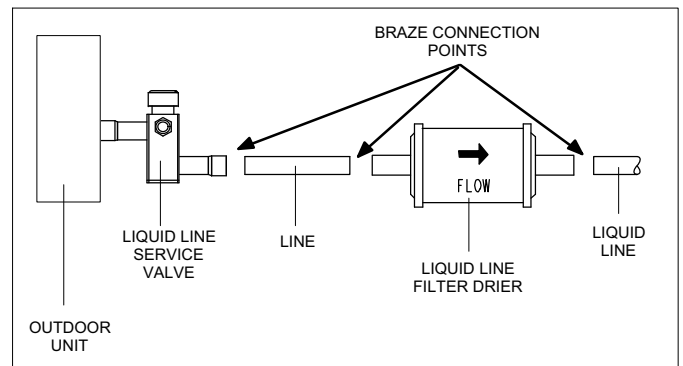

Figure 5. Typical Liquid Line Filter Drier Installation

Table 2. Refrigerant Line Set

Model Number	Field Connections		Recommended Line Set		
	Liquid Line	Suction Line	Liquid Line	Suction Line	L15 — Line Sets
TSA036S4N4	3/8 in. (10 mm)	7/8 in. (22 mm)	3/8 in. (10 mm)	7/8 in. (22 mm)	L15-65 — 15 ft. - 50 ft. (4.6 m - 15 m)
TSA042S4N4					
TSA048S4N4					
TSA060S4N4	3/8 in. (10 mm)	1-1/8 in. (29 mm)	3/8 in. (10 mm)	1-1/8 in. (29 mm)	Field Fabricated

LINE SET

IMPORTANT — Refrigerant lines must not contact structure.

INSTALLATION

Line Set Isolation — The following illustrations are examples of proper refrigerant line set isolation:

REFRIGERANT LINE SET — TRANSITION FROM VERTICAL TO HORIZONTAL

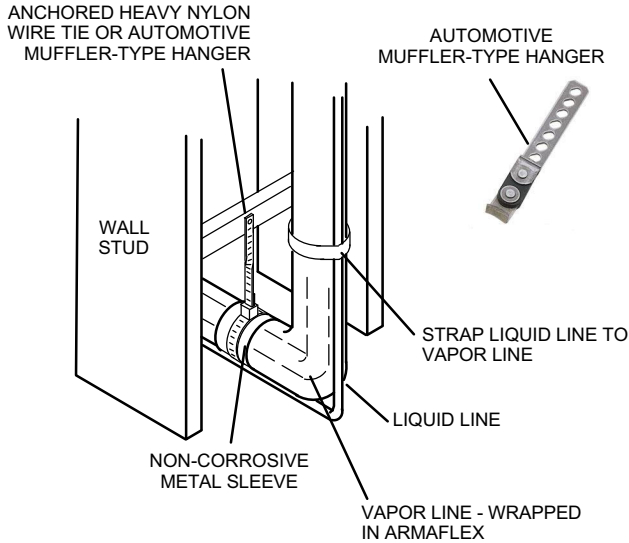

REFRIGERANT LINE SET — INSTALLING HORIZONTAL RUNS

To hang line set from joist or rafter, use either metal strapping material or anchored heavy nylon wire ties.

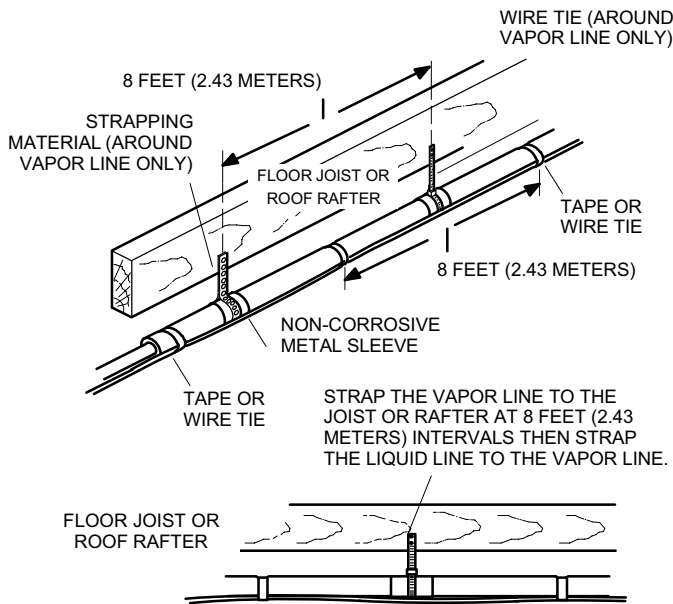

REFRIGERANT LINE SET — INSTALLING VERTICAL RUNS (NEW CONSTRUCTION SHOWN)

NOTE — Insulate liquid line when it is routed through areas where the surrounding ambient temperature could become higher than the temperature of the liquid line or when pressure drop is equal to or greater than 20 psig.

IMPORTANT — Refrigerant lines must not contact wall

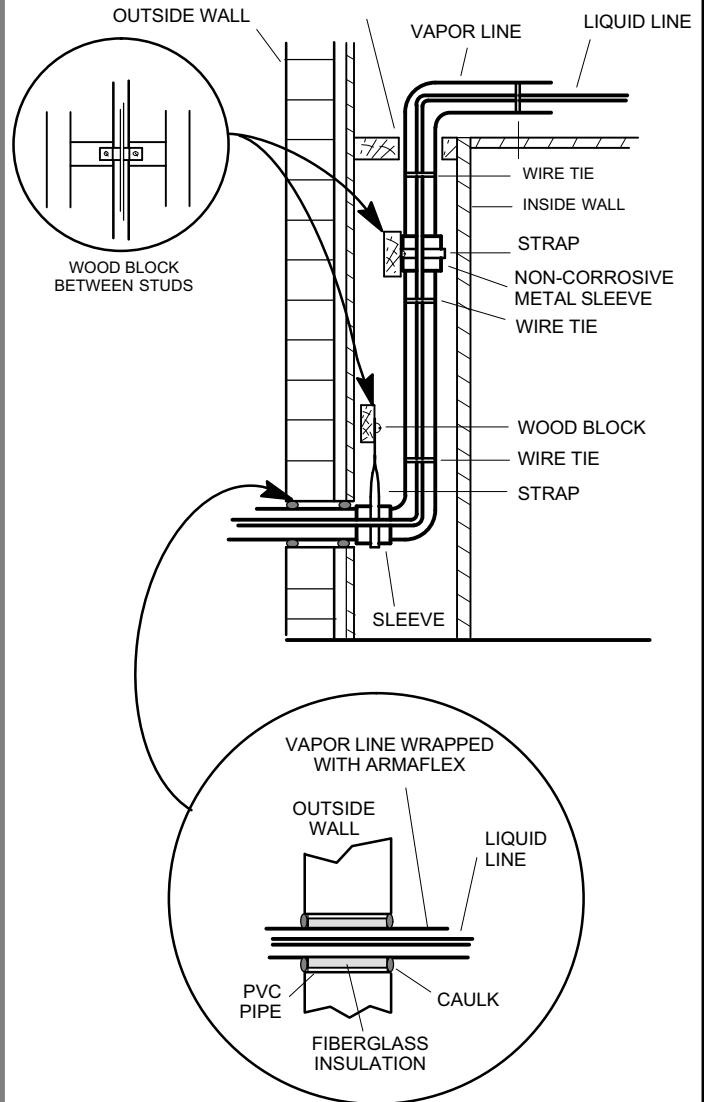

NOTE — Similar installation practices should be used if line set is to be installed on exterior of outside wall.

WARNING — Polyol ester (POE) oils used with HFC-410A refrigerant absorb moisture very quickly. It is very important that the refrigerant system be kept closed as much as possible. **DO NOT** remove line set caps or service valve stub caps until you are ready to make connections.

Figure 6. Line Set Installation

Brazing Connections

Use the procedures outline in figures 7 and 8 for brazing line set connections to service valves.

WARNING



Danger of fire. Bleeding the refrigerant charge from only the high side may result in pressurization of the low side shell and suction tubing. Application of a brazing torch to a pressurized system may result in ignition of the refrigerant and oil mixture - Check the high and low pressures before applying heat.

WARNING



When using a high pressure gas such as dry nitrogen to pressurize a refrigeration or air conditioning system, use a regulator that can control the pressure down to 1 or 2 psig (6.9 to 13.8 kPa).

CAUTION

Brazing alloys and flux contain materials which are hazardous to your health.

Avoid breathing vapors or fumes from brazing operations. Perform operations only in well-ventilated areas.

Wear gloves and protective goggles or face shield to protect against burns.

Wash hands with soap and water after handling brazing alloys and flux.

IMPORTANT

Connect gauge set low pressure side to vapor line service valve and repeat procedure starting at paragraph 4 for brazing the liquid line to service port valve.

IMPORTANT

Allow braze joint to cool before removing the wet rag from the service valve. Temperatures above 250°F can damage valve seals.

IMPORTANT

Use silver alloy brazing rods with 5% minimum silver alloy for copper-to-copper brazing. Use 45% minimum alloy for copper-to-brass and copper-to-steel brazing.

WARNING



Fire, Explosion and Personal Safety Hazard.

Failure to follow this warning could result in damage, personal injury or death.

Never use oxygen to pressurize or purge refrigeration lines. Oxygen, when exposed to a spark or open flame, can cause fire and/or an explosion, that could result in property damage, personal injury or death.

1 CUT AND DEBUR

Cut ends of the refrigerant lines square (free from nicks or dents) and debur the ends. The pipe must remain round. Do not crimp end of the line.

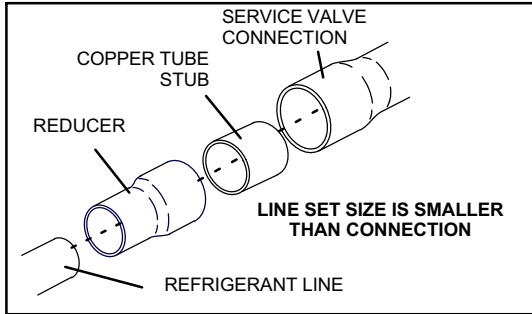
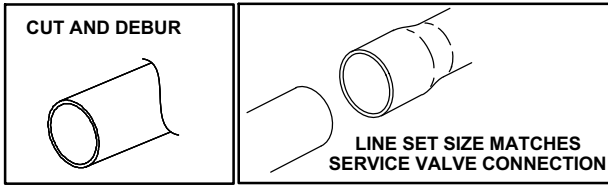

2 CAP AND CORE REMOVAL

Remove service cap and core from both the vapor and liquid line service ports.

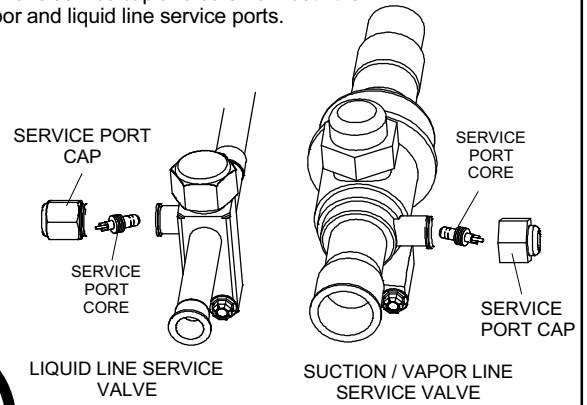

DO NOT CRIMP SERVICE VALVE CONNECTOR WHEN PIPE IS SMALLER THAN CONNECTION

3 ATTACH THE MANIFOLD GAUGE SET FOR BRAZING LIQUID AND SUCTION / VAPOR LINE SERVICE VALVES

Flow regulated nitrogen (at 1 to 2 psig) through the low-side refrigeration gauge set into the liquid line service port valve, and out of the suction / vapor line service port valve.

- A Connect gauge set low pressure side to liquid line service valve (service port).
- B Connect gauge set center port to bottle of nitrogen with regulator.
- C Remove Schrader valve in suction / vapor line service port to allow nitrogen to escape.

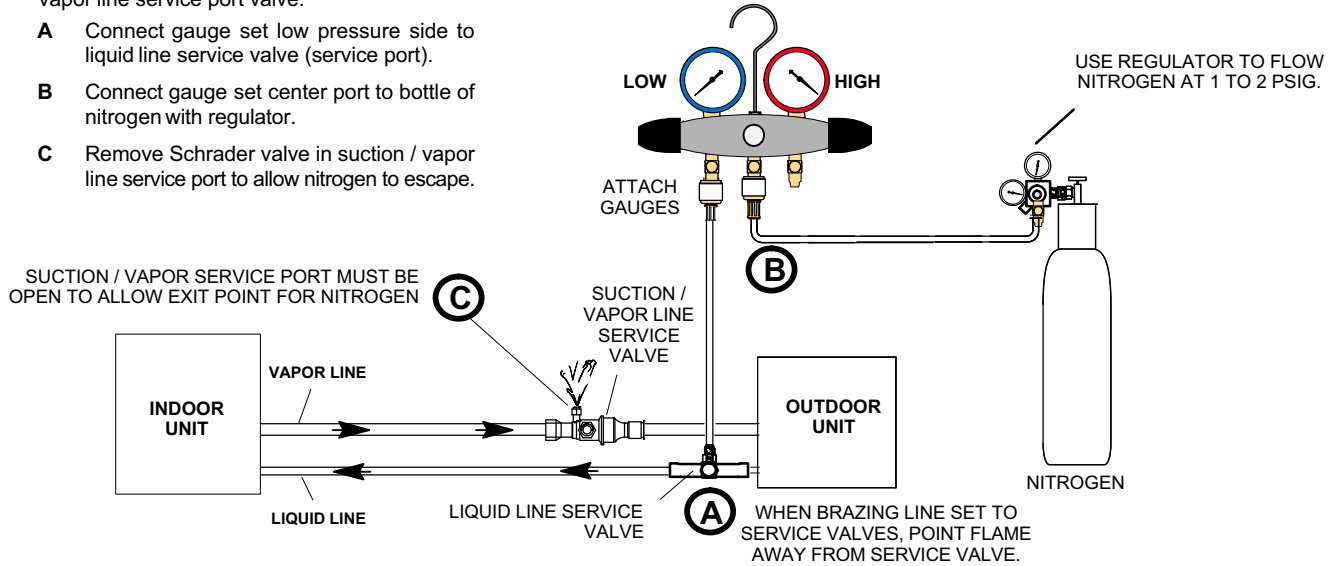

Figure 7. Brazing Procedures

4 WRAP SERVICE VALVES

To help protect service valve seals during brazing, wrap a saturated cloth around service valve bodies and copper tube stub. Use another saturated cloth underneath the valve body to protect the base paint.

5 FLOW NITROGEN

Flow regulated nitrogen (at 1 to 2 psig) through the refrigeration gauge set into the valve stem port connection on the liquid service valve and out of the suction / vapor valve stem port. See steps **3A**, **3B** and **3C** on manifold gauge set connections

6 BRAZE LINE SET

Wrap both service valves with a saturated cloth as illustrated here before brazing to line set.

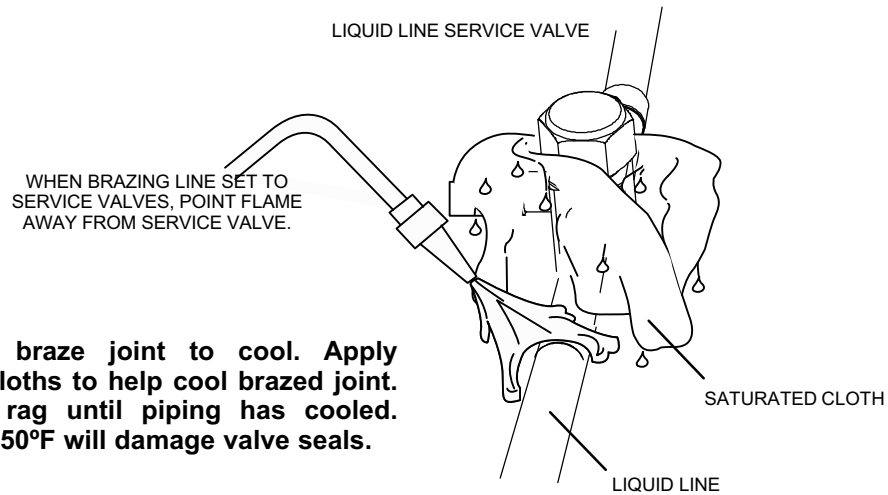

IMPORTANT — Allow braze joint to cool. Apply additional saturated cloths to help cool brazed joint. Do not remove wet rag until piping has cooled. Temperatures above 250°F will damage valve seals.

WARNING

1. **FIRE, PERSONAL INJURY, OR PROPERTY DAMAGE** will result if you do not wrap a wet cloth around both liquid and suction line service valve bodies and copper tube stub while brazing in the line set! The braze, when complete, must be quenched with water to absorb any residual heat.
2. Do not open service valves until refrigerant lines and indoor coil have been leak-tested and evacuated. Refer to procedures provided in this supplement.

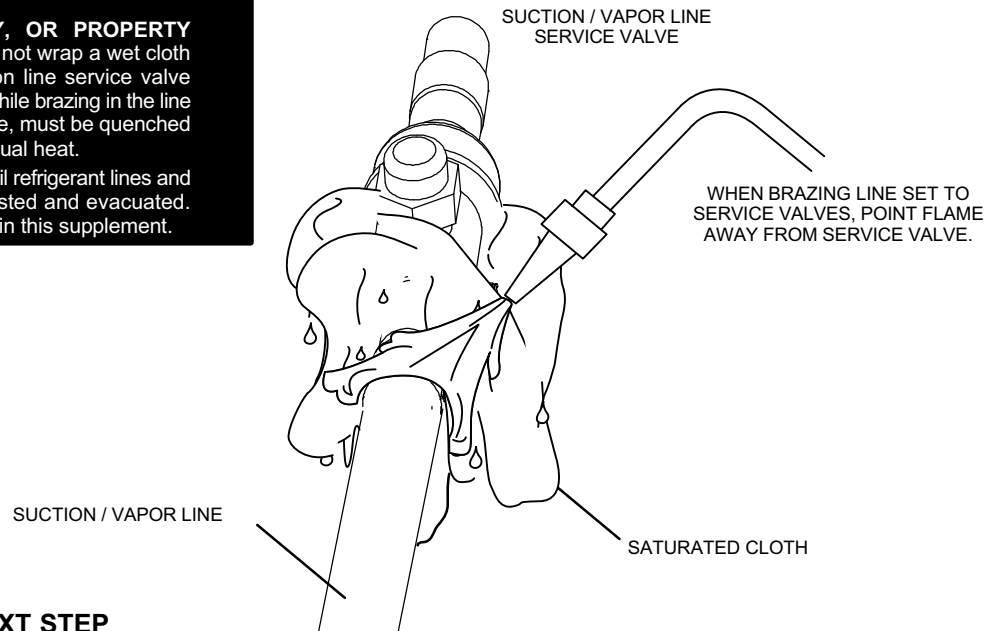

7 PREPARATION FOR NEXT STEP

After all connections have been brazed, disconnect manifold gauge set from service ports. Apply saturated rags to both services valves to cool piping. Once piping is cool, remove all wet cloths. Refer to the unit installation instructions for the next step in preparing the unit.

Figure 8. Brazing Procedures (continued)

Flushing Line Set and Indoor Coil

Flushing is only required if existing indoor coil and line set are to be used. Otherwise proceed to *Installing Indoor Metering Device* on page 13.

1A TYPICAL EXISTING FIXED ORIFICE REMOVAL PROCEDURE (UNCASED OR COIL SHOWN)

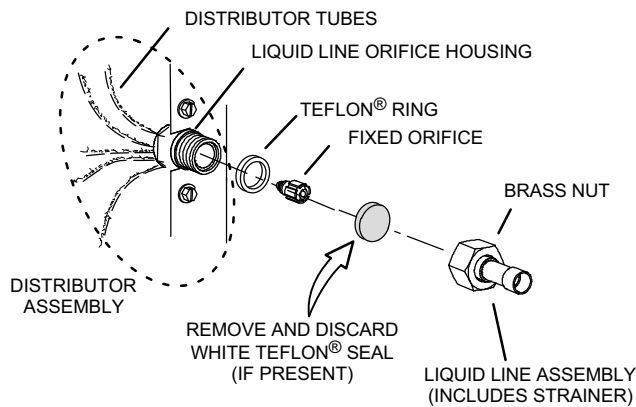

- A** On fully cased coils, remove the coil access and plumbing panels.
- B** Remove any shipping clamps holding the liquid line and distributor assembly.
- C** Using two wrenches, disconnect liquid line from liquid line orifice housing. Take care not to twist or damage distributor tubes during this process.
- D** Remove and discard fixed orifice, valve stem assembly if present and Teflon® washer as illustrated above.
- E** Use a field-provided fitting to temporary reconnect the liquid line to the indoor unit's liquid line orifice housing.

1B TYPICAL EXISTING EXPANSION VALVE REMOVAL PROCEDURE (UNCASED COIL SHOWN)

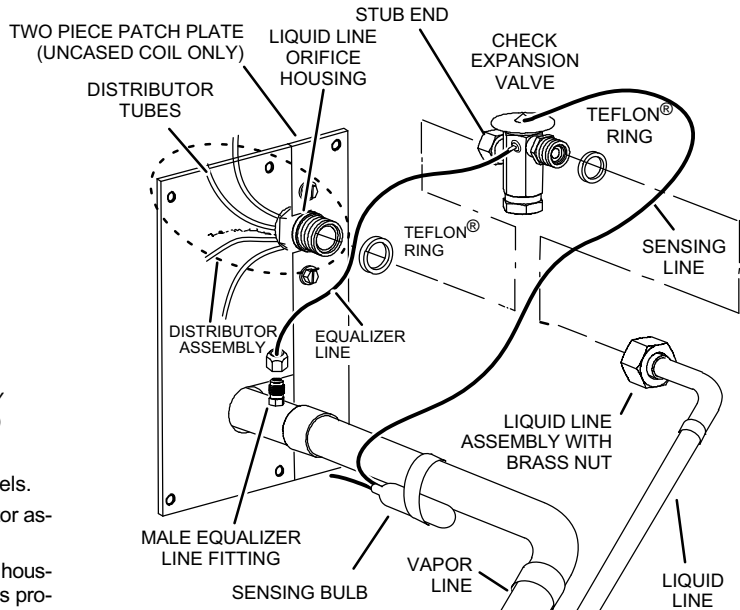

- A** On fully cased coils, remove the coil access and plumbing panels.
- B** Remove any shipping clamps holding the liquid line and distributor assembly.
- C** Disconnect the equalizer line from the check expansion valve equalizer line fitting on the vapor line.
- D** Remove the vapor line sensing bulb.
- E** Disconnect the liquid line from the check expansion valve at the liquid line assembly.
- F** Disconnect the check expansion valve from the liquid line orifice housing. Take care not to twist or damage distributor tubes during this process.
- G** Remove and discard check expansion valve and the two Teflon® rings.
- H** Use a field-provided fitting to temporary reconnect the liquid line to the indoor unit's liquid line orifice housing.

2 CONNECT GAUGES AND EQUIPMENT FOR FLUSHING PROCEDURE

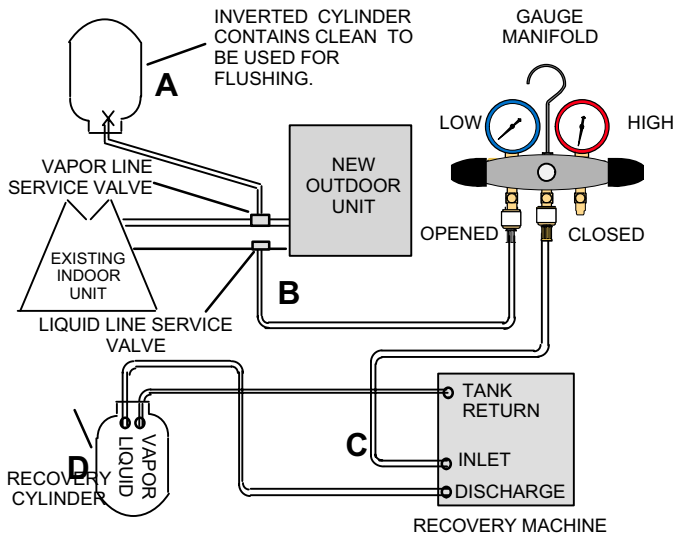

- A** Inverted cylinder with clean refrigerant to the vapor service valve.
- B** gauge set (low side) to the liquid line valve.
- C** gauge set center port to inlet on the recovery machine with an empty recovery tank to the gauge set.
- D** Connect recovery tank to recovery machines per machine instructions.

3 FLUSHING LINE SET

The line set and indoor unit coil must be flushed with at least the same amount of clean refrigerant that previously charged the system. Check the charge in the flushing cylinder before proceeding.

- A** Set the recovery machine for liquid recovery and start the recovery machine. Open the gauge set valves to allow the recovery machine to pull a vacuum on the existing system line set and indoor unit coil.
- B** Invert the cylinder of clean and open its valve to allow liquid refrigerant to flow into the system through the vapor line valve. Allow the refrigerant to pass from the cylinder and through the line set and the indoor unit coil before it enters the recovery machine.
- C** After all of the liquid refrigerant has been recovered, switch the recovery machine to vapor recovery so that all of the vapor is recovered. Allow the recovery machine to pull down to 0 the system.
- D** Close the valve on the inverted drum and the gauge set valves. Pump the remaining refrigerant out of the recovery machine and turn the machine off.

Figure 9. Removing Metering Device and Flushing

Installing Indoor Metering Device

This outdoor unit is designed for use in systems that use either an fixed orifice (RFC) (included with outdoor unit), or expansion valve metering device (purchased separately) at the indoor coil.

See the *Lennox TSA*S4 Engineering Handbook* for approved expansion valve kit match ups. The expansion valve unit can be installed internal or external to the indoor

coil. In applications where an uncased coil is being installed in a field-provided plenum, install the expansion valve in a manner that will provide access for field servicing of the expansion valve. Refer to below illustration for reference during installation of expansion valve unit. .

After installation of the indoor coil metering device, proceed to *Leak Test Line Set and Indoor Coil* on page 14.

INDOOR EXPANSION VALVE INSTALLATION

(Uncased Coil Shown)

Labels in diagram: TWO PIECE PATCH PLATE (UNCASED COIL ONLY), DISTRIBUTOR TUBES, DISTRIBUTOR ASSEMBLY, MALE EQUALIZER LINE FITTING (SEE EQUALIZER LINE INSTALLATION FOR FURTHER DETAILS), LIQUID LINE ORIFICE HOUSING, STUB END, EXPANSION VALVE, TEFLON® RING, SENSING LINE, EQUALIZER LINE, LIQUID LINE ASSEMBLY WITH BRASS NUT, VAPOR LINE, LIQUID LINE.

Sensing bulb insulation is required if mounted external to the coil casing. sensing bulb installation for bulb positioning.

- Remove the field-provided fitting that temporary reconnected the liquid line to the indoor unit's distributor assembly.
- Install one of the provided Teflon® rings around the stubbed end of the expansion valve and lightly lubricate the connector threads and expose surface of the Teflon® ring with refrigerant oil.
- Attach the stubbed end of the expansion valve to the liquid line orifice housing. Finger tighten and use an appropriately sized wrench to turn an additional 1/2 turn clockwise as illustrated in the figure above, or 20 ft-lb.
- Place the remaining Teflon® washer around the other end of the expansion valve. Lightly lubricate connector threads and expose surface of the Teflon® ring with refrigerant oil.
- Attach the liquid line assembly to the expansion valve. Finger tighten and use an appropriately sized wrench to turn an additional 1/2 turn clockwise as illustrated in the figure above or 20 ft-lb.

1/2 Turn

EQUALIZER LINE INSTALLATION

- Remove and discard either the flare seal cap or flare nut with copper flare seal bonnet from the equalizer line port on the vapor line as illustrated in the figure to the right.
- Remove and discard either the flare seal cap or flare nut with copper flare seal bonnet from the equalizer line port on the vapor line as illustrated in the figure to the right.

Labels: FLARE SEAL CAP, FLARE NUT, COPPER FLARE SEAL BONNET, MALE BRASS EQUALIZER LINE FITTING, VAPOR LINE.

SENSING BULB INSTALLATION

- Attach the vapor line sensing bulb in the proper orientation as illustrated to the right using the clamp and screws provided.

NOTE — Confirm proper thermal contact between vapor line and expansion bulb before insulating the sensing bulb once installed.

- Connect the equalizer line from the expansion valve to the equalizer vapor port on the vapor line. Finger tighten the flare nut plus 1/8 turn (7 ft-lbs) as illustrated below.

Labels: VAPOR LINE, BULB.

ON LINES SMALLER THAN 7/8", MOUNT SENSING BULB AT EITHER THE 3 OR 9 O'CLOCK POSITION.

ON 7/8" AND LARGER LINES, MOUNT SENSING BULB AT EITHER THE 4 OR 8 O'CLOCK POSITION. NEVER MOUNT ON BOTTOM OF LINE.

NOTE — NEVER MOUNT ON BOTTOM OF LINE.

1/8 Turn

Figure 10. Installing Indoor Expansion Valve

⚠ IMPORTANT

The Environmental Protection Agency (EPA) prohibits the intentional venting of HFC refrigerants during maintenance, service, repair and disposal of appliance. Approved methods of recovery, recycling or reclaiming must be followed.

⚠ IMPORTANT

If this unit is being matched with an approved line set or indoor unit coil which was previously charged with mineral oil, or if it is being matched with a coil which was manufactured before January of 1999, the coil and line set must be flushed prior to installation. Take care to empty all existing traps. Polyol ester (POE) oils are used in Lennox units charged with HFC-410A refrigerant. Residual mineral oil can act as an insulator, preventing proper heat transfer. It can also clog the expansion device, and reduce the system performance and capacity.

Failure to properly flush the system per the instructions below will void the warranty.

Leak Test Line Set and Indoor Coil

⚠ IMPORTANT

Leak detector must be capable of sensing HFC refrigerant.

After completing the leak testing the line set and indoor coil as outlined in figure 11, proceed to *Evacuating Line Set and Indoor Coil* on page 15.

⚠ WARNING



When using a high pressure gas such as dry nitrogen to pressurize a refrigeration or air conditioning system, use a regulator that can control the pressure down to 1 or 2 psig (6.9 to 13.8 kPa).

⚠ WARNING

Refrigerant can be harmful if it is inhaled. Refrigerant must be used and recovered responsibly.

Failure to follow this warning may result in personal injury or death.

1 CONNECT GAUGE SET

- A** Connect an HFC-410A manifold gauge set high pressure hose to the vapor valve service port.

NOTE — Normally, the high pressure hose is connected to the liquid line port. However, connecting it to the vapor port better protects the manifold gauge set from high pressure damage.

- B** With both manifold valves closed, connect the cylinder of HFC-410A refrigerant to the center port of the manifold gauge set.

NOTE — Later in the procedure, the HFC-410A container will be replaced by the nitrogen container.

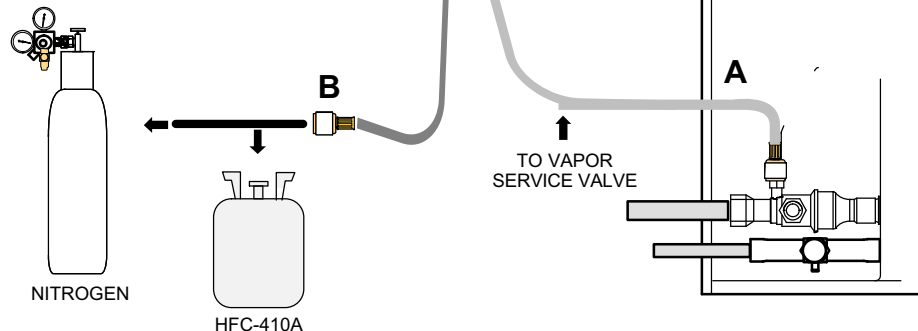

2 TEST FOR LEAKS

After the line set has been connected to the indoor and outdoor units, check the line set connections and indoor unit for leaks. Use the following procedure to test for leaks:

- A** With both manifold valves closed, connect the cylinder of HFC-410A refrigerant to the center port of the manifold gauge set. Open the valve on the HFC-410A cylinder (vapor only).
- B** Open the high pressure side of the manifold to allow HFC-410A into the line set and indoor unit. Weigh in a trace amount of HFC-410A. [A trace amount is a maximum of two ounces (57 g) refrigerant or three pounds (31 kPa) pressure]. Close the valve on the HFC-410A cylinder and the valve on the high pressure side of the manifold gauge set. Disconnect the HFC-410A cylinder.
- C** Connect a cylinder of dry nitrogen with a pressure regulating valve to the center port of the manifold gauge set.
- D** Adjust dry nitrogen pressure to 150 psig (1034 kPa). Open the valve on the high side of the manifold gauge set in order to pressurize the line set and the indoor unit.
- E** After a few minutes, open one of the service valve ports and verify that the refrigerant added to the system earlier is measurable with a leak detector.
- F** After leak testing disconnect gauges from service ports.

Figure 11. Leak Test

Evacuating Line Set and Indoor Coil

1 CONNECT GAUGE SET

NOTE — Remove cores from service valves (if not already done).

- A** Connect low side of manifold gauge set with 1/4 SAE in-line tee to vapor line service valve
- B** Connect high side of manifold gauge set to liquid line service valve
- C** Connect micron gauge available connector on the 1/4 SAE in-line tee.
- D** Connect the vacuum pump (with vacuum gauge) to the center port of the manifold gauge set. The center port line will be used later for both the HFC-410A and nitrogen containers.

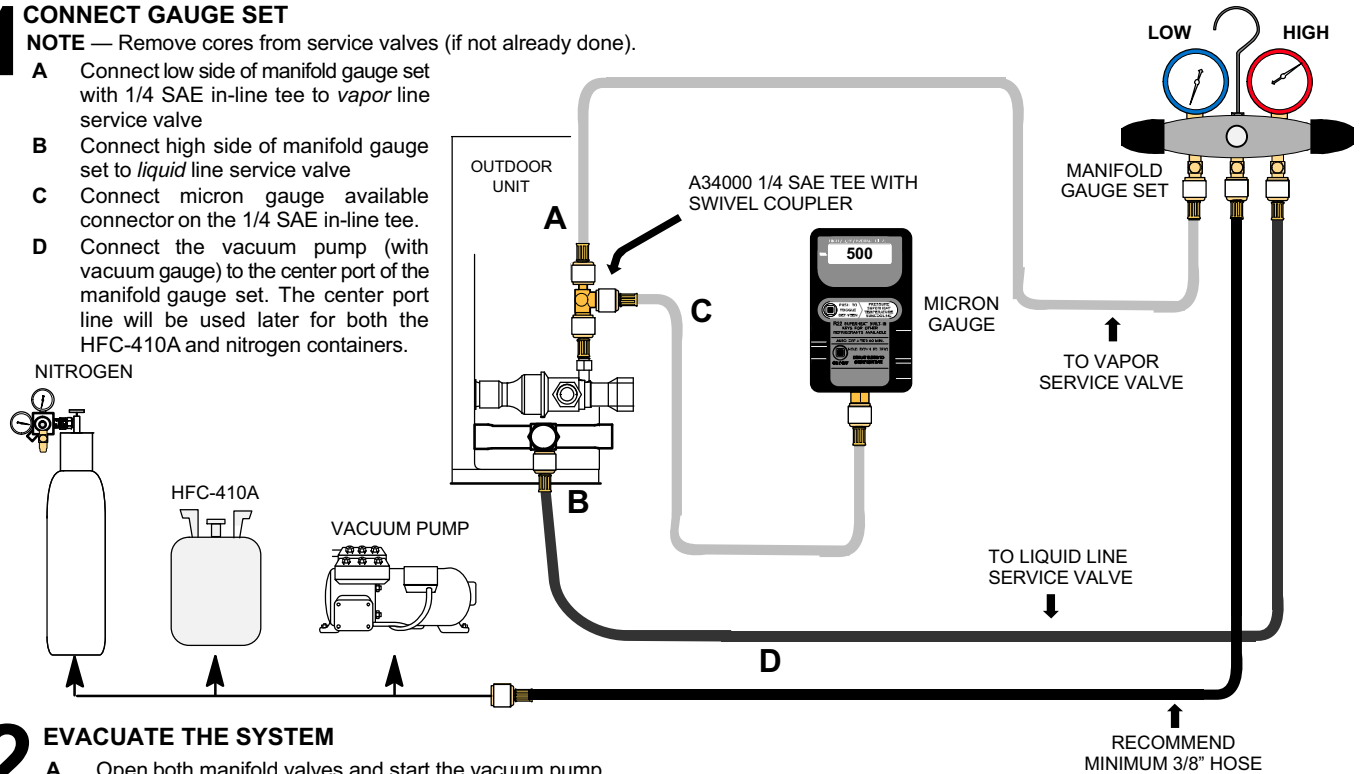

2 EVACUATE THE SYSTEM

- A** Open both manifold valves and start the vacuum pump.
- B** Evacuate the line set and indoor unit to an **absolute pressure** of 23,000 microns (29.01 inches of mercury).
 - NOTE** — During the early stages of evacuation, it is desirable to close the manifold gauge valve at least once. A rapid rise in pressure indicates a relatively large leak. If this occurs, **repeat the leak testing procedure**.
 - NOTE** — The term **absolute pressure** means the total actual pressure within a given volume or system, above the absolute zero of pressure. Absolute pressure in a vacuum is equal to atmospheric pressure minus vacuum pressure.
- C** When the absolute pressure reaches 23,000 microns (29.01 inches of mercury), perform the following:
 - Close manifold gauge valves
 - Close valve on vacuum pump
 - Turn off vacuum pump
 - Disconnect manifold gauge center port hose from vacuum pump
 - Attach manifold center port hose to a dry nitrogen cylinder with pressure regulator set to 150 psig (1034 kPa) and purge the hose.
 - Open manifold gauge valves to break the vacuum in the line set and indoor unit.
 - Close manifold gauge valves.
- D** Shut off the dry nitrogen cylinder and remove the manifold gauge hose from the cylinder. Open the manifold gauge valves to release the dry nitrogen from the line set and indoor unit.
- E** Reconnect the manifold gauge to the vacuum pump, turn the pump on, and continue to evacuate the line set and indoor unit until the absolute pressure does not rise above 500 microns (29.9 inches of mercury) within a 20-minute period after shutting off the vacuum pump and closing the manifold gauge valves.
- F** When the absolute pressure requirement above has been met, disconnect the manifold hose from the vacuum pump and connect it to an upright cylinder of HFC-410A refrigerant. Open the manifold gauge valve 1 to 2 psig in order to release the vacuum in the line set and indoor unit.
- G** Perform the following:
 - Close manifold gauge valves.
 - Shut off HFC-410A cylinder.
 - Reinstall service valve cores by removing manifold hose from service valve. Quickly install cores with core tool while maintaining a positive system pressure.
 - Replace stem caps and secure finger tight, then tighten an additional one-sixth (1/6) of a turn as illustrated.

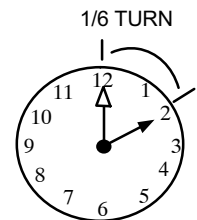

Figure 12. Evacuating System

Electrical Connections

Refer to the indoor unit installation instruction for additional wiring application diagrams and refer to unit nameplate for minimum circuit ampacity and maximum overcurrent protection size. Figures 14 and 15 illustrate typical outdoor unit wiring diagrams for the TSA*S4 series heat pumps.

- In the U.S.A., wiring must conform with current local codes and the current National Electric Code (NEC).
- In Canada, wiring must conform with current local codes and the current Canadian Electrical Code (CEC).

⚠ WARNING



Electric Shock Hazard. Can cause injury or death.

Line voltage is present at all components on units with single-pole contactors, even when unit is not in operation!

Unit may have multiple power supplies. Disconnect all remote electric power supplies before opening access panel.

Unit must be grounded in accordance with national and local codes.

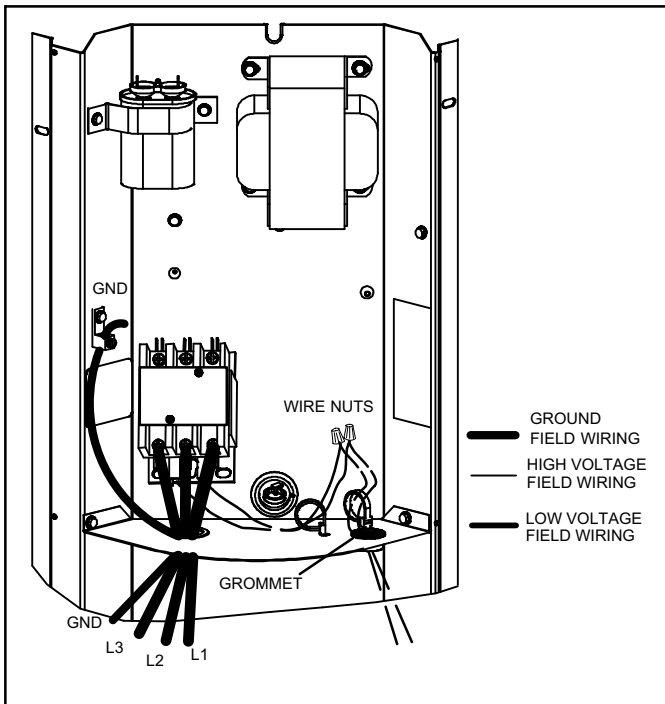

Figure 13. Separating High/Low Voltage Field Wiring (Typical Field Wiring)

WIRING CONNECTIONS

1. Install line voltage power supply to unit from a properly sized disconnect switch. Any excess high voltage field

wiring should be trimmed or secured away from the low voltage field wiring.

2. Ground unit at unit disconnect switch or to an earth ground.
3. Connect conduit to the unit using provided conduit bushing.
4. Install room thermostat (ordered separately) on an inside wall approximately in the center of the conditioned area and five feet (1.5 m) from the floor. It should not be installed on an outside wall or where it can be affected by sunlight, drafts or vibrations.

NOTE - For proper voltages, select thermostat wire gauge per the following table:

Table 3. Wire Run Lengths

Wire run length	AWG #	Insulation type
Less than 100 feet (30 m)	18	Color-coded with a minimum temperature rating of 35°C.
More than 100 feet (30 m)	16	

5. Install low voltage wiring from outdoor to indoor unit and from thermostat to indoor unit as illustrated in figures 14 and 15.
6. Do not bundle any excess 24VAC control wire inside control box. Run control wire through installed wire tie and tighten wire tie to provided low voltage strain relief and to maintain separation of field installed low and high voltage circuits.

NOTE - 24VAC, Class II circuit connections are made in the low voltage junction box

NOTE - Units are approved for use only with copper conductors.

NOTE - To facilitate conduit, a hole is in the bottom of the control box. Connect conduit to the control box using a proper conduit fitting.

NOTE - See unit wiring diagram for power supply connections. If indoor unit is not equipped with blower relay. It must be field-provided and installed (P-8-3251 or equivalent)

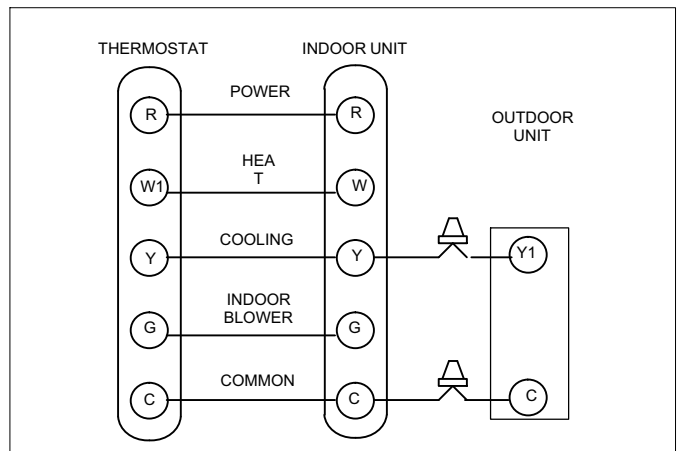

Figure 14. Typical Field Low Voltage Wiring

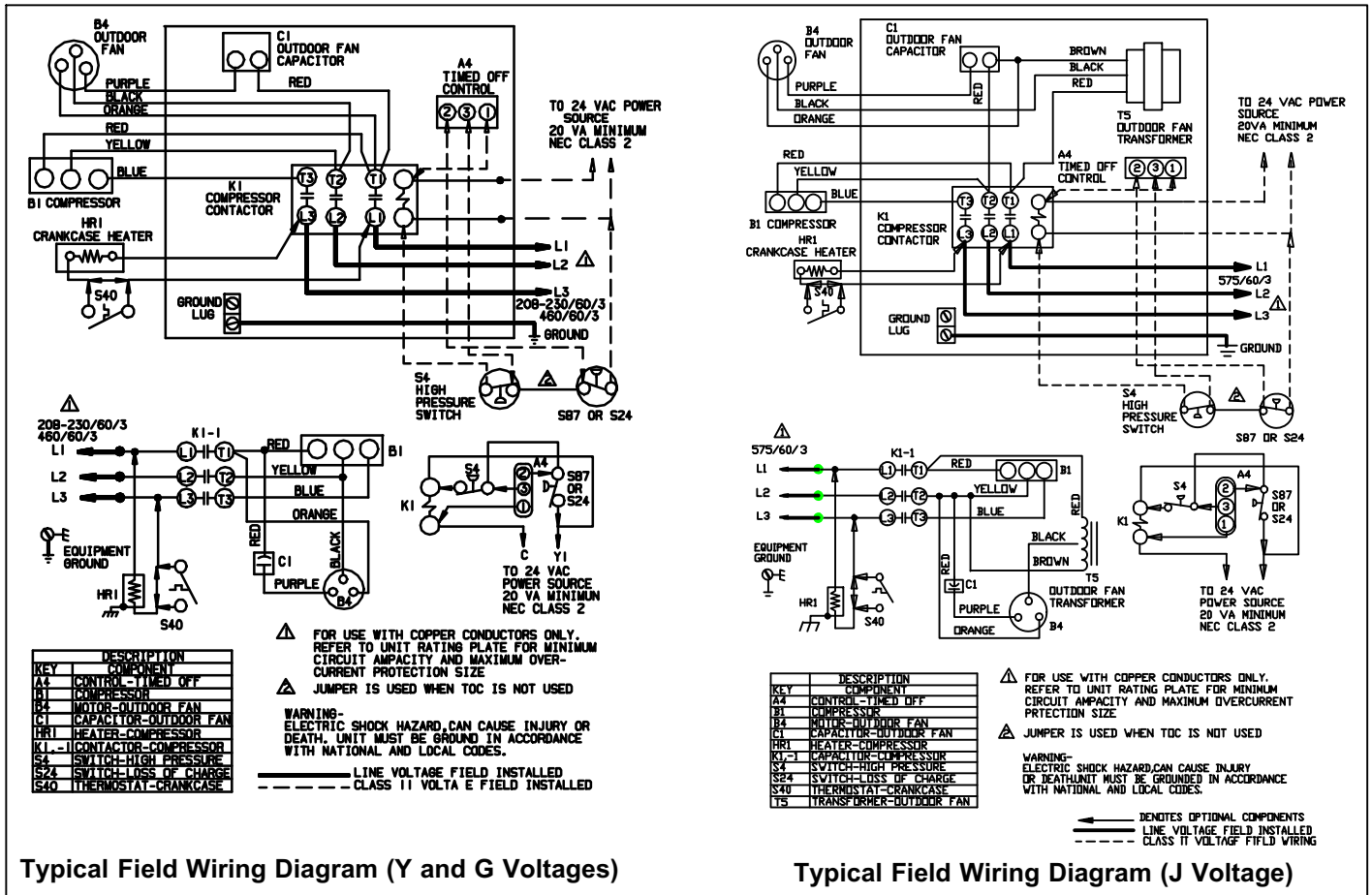

Figure 15. Typical Wiring Diagram

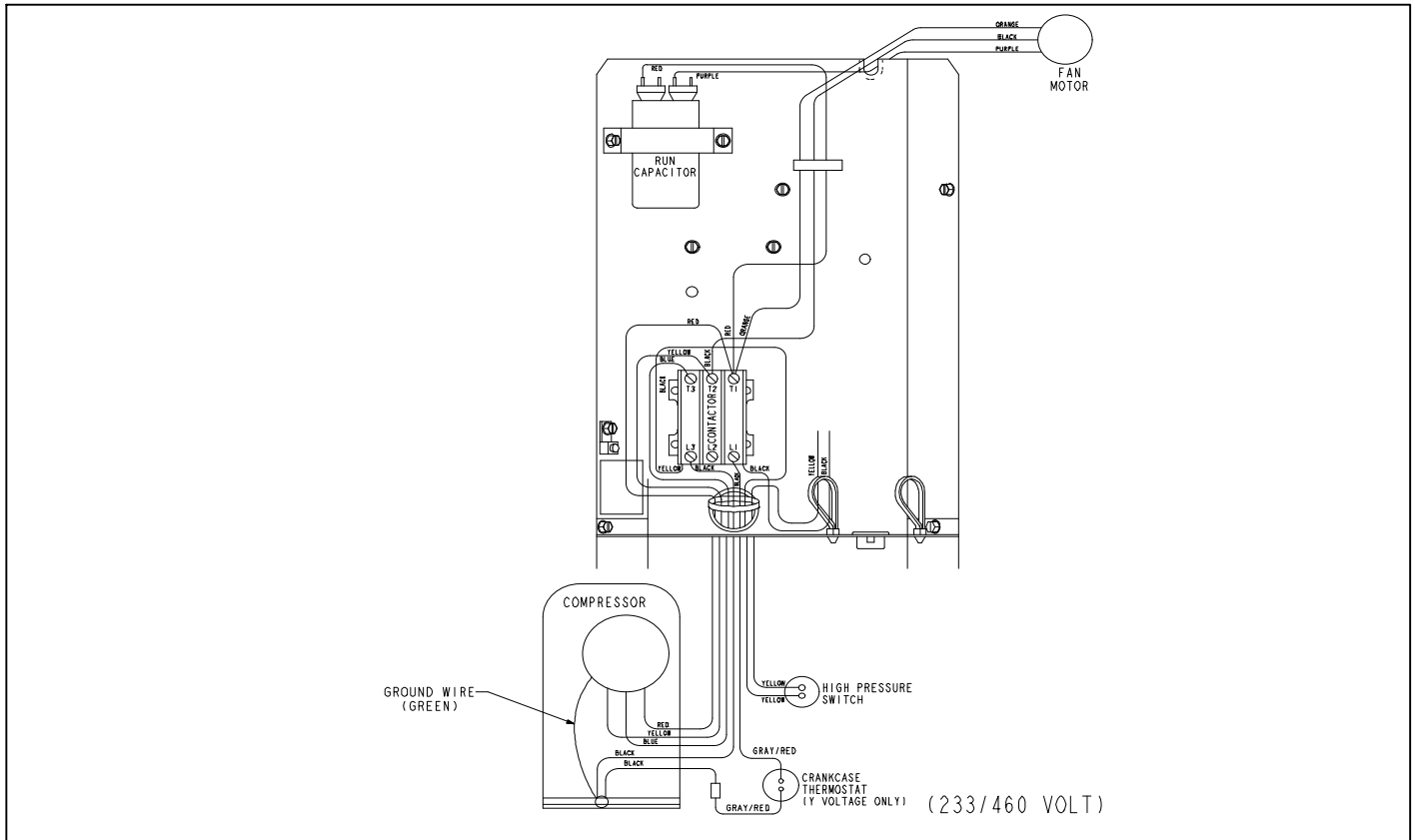

Figure 16. Typical Factory Wiring Diagram

Servicing Unit Delivered Void of Charge

If the outdoor unit is void of refrigerant, clean the system using the procedure described below.

1. Leak check system using procedure outlined on page 14.
2. Evacuate the system using procedure outlined on page 15.
3. Use nitrogen to break the vacuum and install a new filter drier in the system.
4. Evacuate the system again using procedure outlined on page 15.
5. Weigh in refrigerant using procedure outlined in figure 20.

Start-Up

⚠ IMPORTANT

Crankcase heater (if applicable) should be energized 24 hours before unit start-up to prevent compressor damage as a result of slugging.

1. Check that fan rotates freely.
2. Inspect all factory- and field-installed wiring for loose connections.

3. Open the liquid line and suction line service valves to release the refrigerant charge (contained in outdoor unit) into the system.
4. Replace the stem caps and tighten as specified in *Operating Service Valves* on page 3.
5. Check voltage supply at the disconnect switch. The voltage must be within the range listed on the unit's nameplate. If not, do not start the equipment until you have consulted with the power company and the voltage condition has been corrected.
6. Set the thermostat for a cooling demand. Turn on power to the indoor indoor unit and close the outdoor unit disconnect switch to start the unit.
7. Recheck voltage while the unit is running. Power must be within range shown on the nameplate.
8. Check system for sufficient refrigerate by using the procedures listed under *System Refrigerant*.

System Refrigerant

This section outlines procedures for:

1. Connecting gauge set for testing and charging;
2. Checking and adjusting indoor airflow;
3. Adding or removing refrigerant.

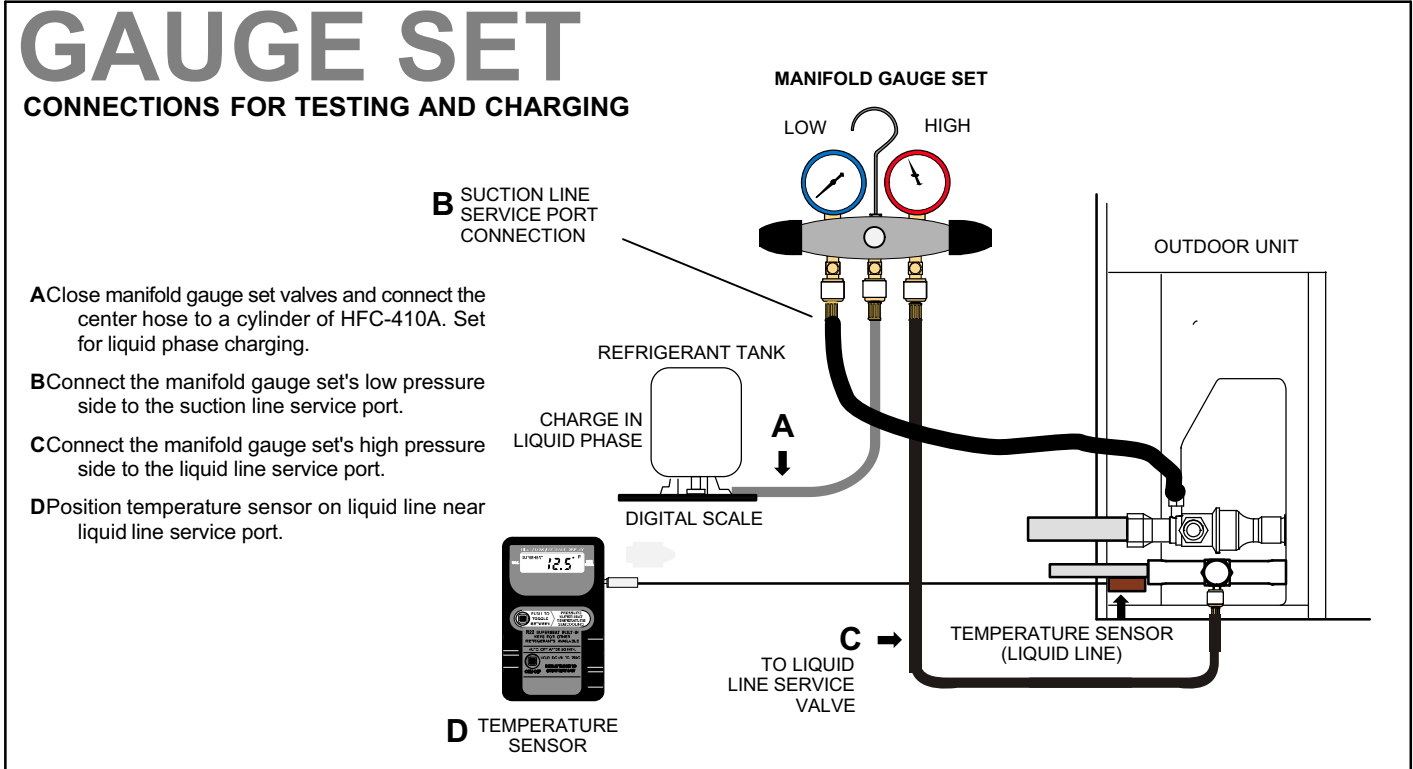

Figure 17. Manifold Gauge Set Setup and Connections

CHECKING AIR FLOW AT INDOOR COIL

Check airflow using the Delta-T (DT) process using the illustration in figure 18.

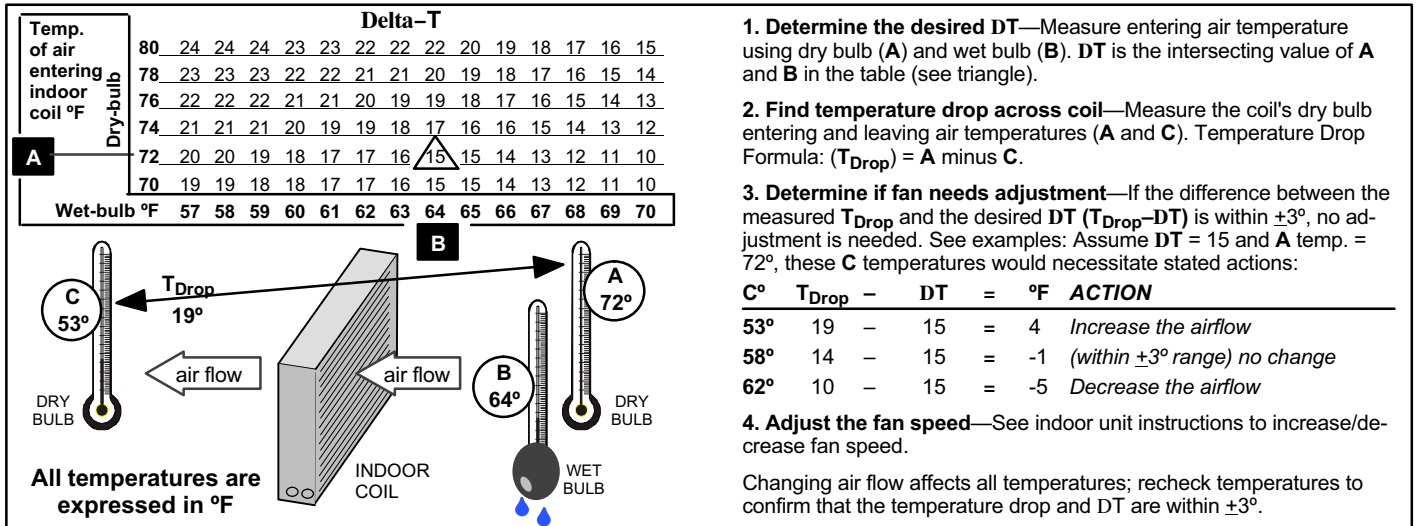

Figure 18. Checking Indoor Airflow over Evaporator Coil using Delta-T Chart

Use **WEIGH IN** method for adding initial refrigerant charge, and then use **SUBCOOLING** method for verifying refrigerant charge.

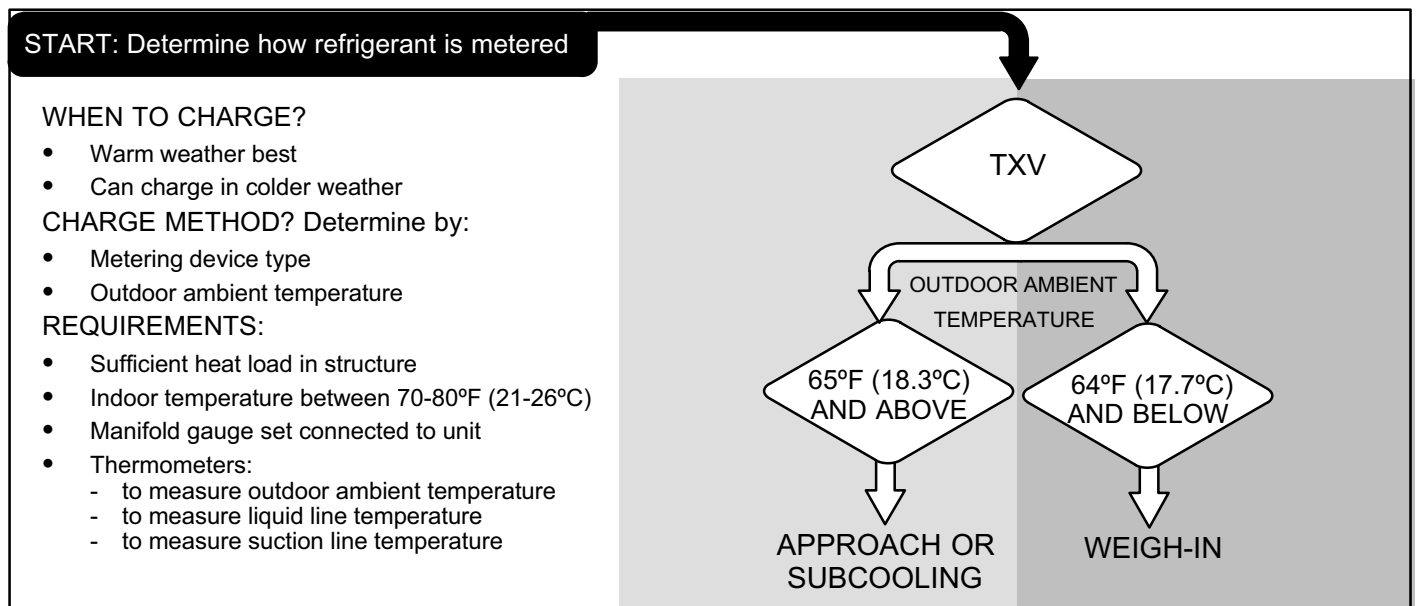

Figure 19. Determining Charge Method

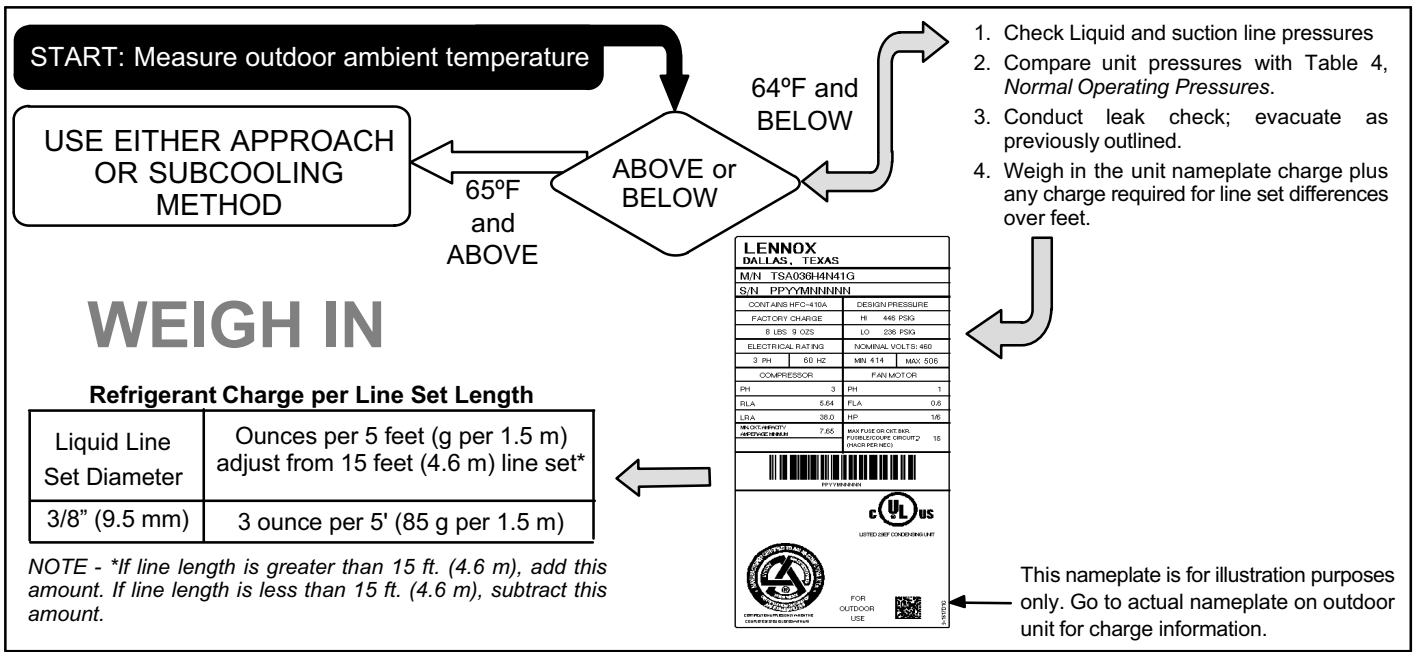

Figure 20. Weigh In Method

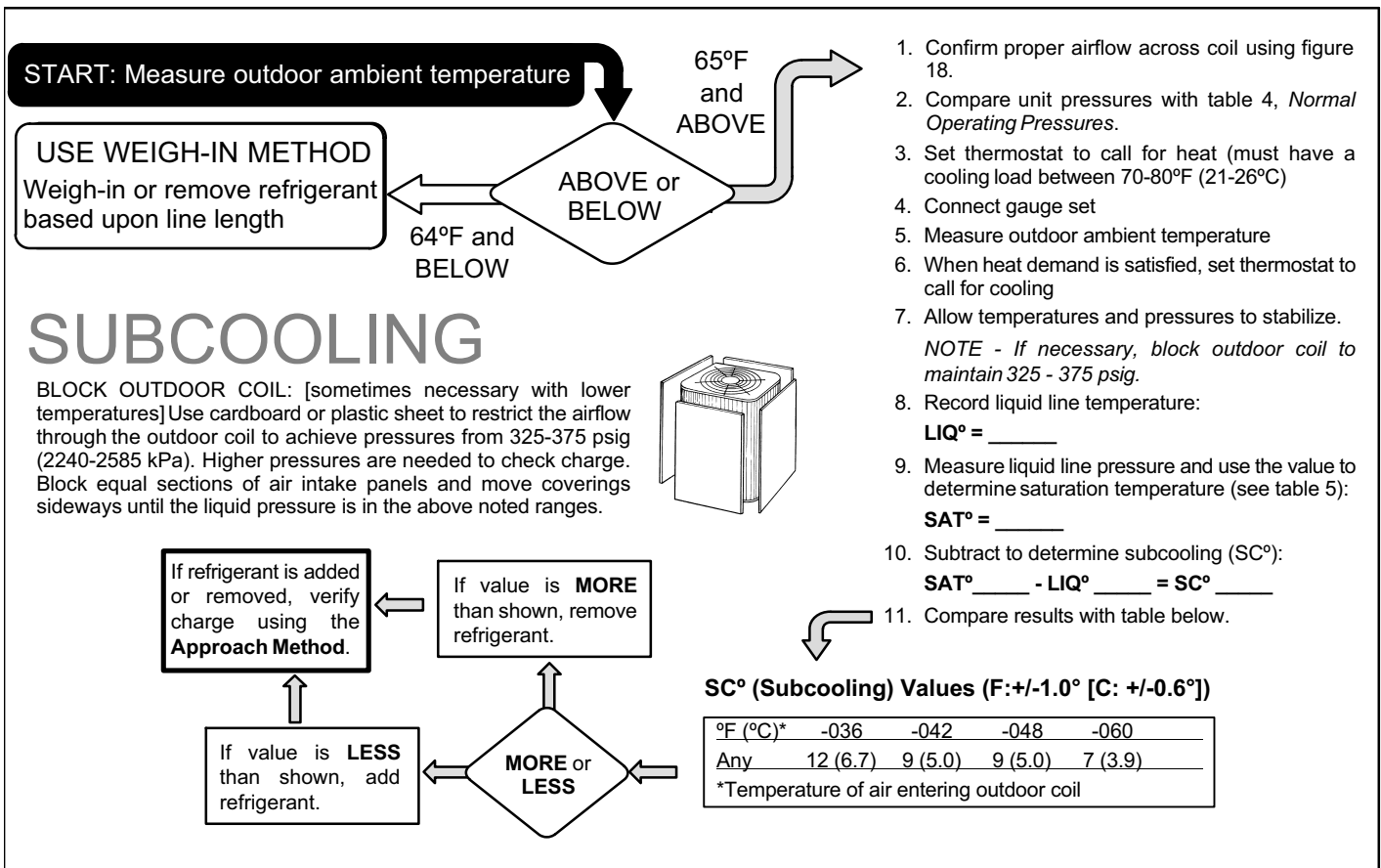

Figure 21. HFC-410A Subcooling TXV Charge

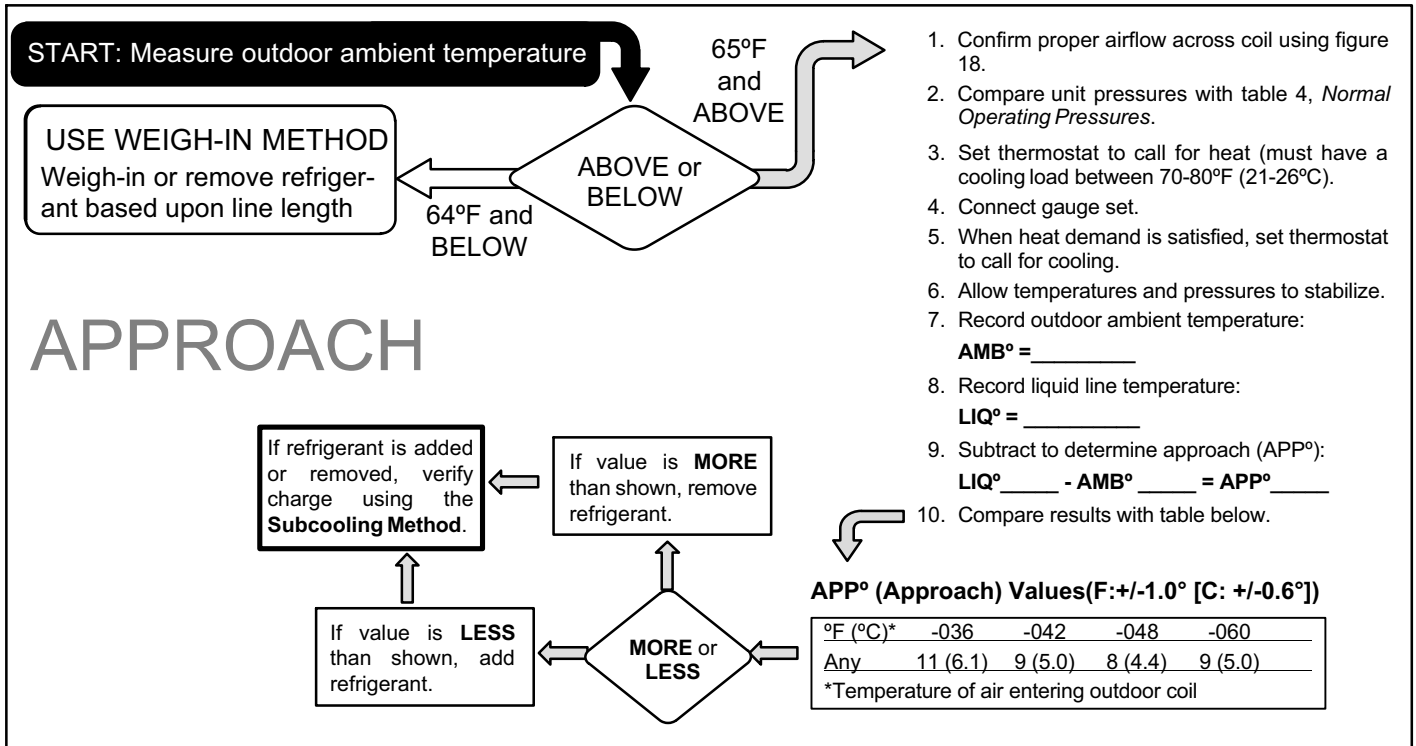

Figure 22. HFC-410A Approach TXV Charge

Table 4. HFC-410A Normal Operating Pressures (Liquid +10 and Suction +5 psig)

! IMPORTANT

Use this table to perform maintenance checks; it is not a procedure for charging the system. Minor variations in these pressures may be due to differences in installations. Significant deviations could mean that the system is not properly charged or that a problem exists with some component in the system.

TSA*S4	-036	-042	-048	-060
°F (°C)*	Liquid / Suction	Liquid / Suction	Liquid / Suction	Liquid / Suction
Expansion Valve (TXV)				
65 (18)	263 / 135	238 / 132	235 / 132	241 / 130
70 (21)	281 / 138	262 / 133	254 / 132	260 / 130
75 (24)	302 / 140	280 / 134	276 / 134	280 / 132
80 (27)	325 / 142	301 / 136	298 / 134	299 / 134
85 (29)	349 / 142	327 / 137	323 / 135	321 / 135
90 (32)	375 / 143	353 / 138	350 / 137	344 / 134
95 (35)	404 / 144	377 / 140	377 / 138	371 / 135
100 (38)	433 / 145	404 / 141	406 / 140	400 / 137
105 (41)	462 / 147	435 / 142	430 / 141	428 / 139
110 (43)	494 / 149	465 / 143	464 / 142	458 / 141
115 (45)	527 / 150	499 / 144	495 / 143	484 / 142

Table 5. HFC-410A Temperature (°F) - Pressure (Psig)

°F	Psig	°F	Psig	°F	Psig	°F	Psig	°F	Psig	°F	Psig	°F	Psig	°F	Psig
32	100.8	48	137.1	63	178.5	79	231.6	94	290.8	110	365.0	125	445.9	141	545.6
33	102.9	49	139.6	64	181.6	80	235.3	95	295.1	111	370.0	126	451.8	142	552.3
34	105.0	50	142.2	65	184.3	81	239.0	96	299.4	112	375.1	127	457.6	143	559.1
35	107.1	51	144.8	66	187.7	82	242.7	97	303.8	113	380.2	128	463.5	144	565.9
36	109.2	52	147.4	67	190.9	83	246.5	98	308.2	114	385.4	129	469.5	145	572.8
37	111.4	53	150.1	68	194.1	84	250.3	99	312.7	115	390.7	130	475.6	146	579.8
38	113.6	54	152.8	69	197.3	85	254.1	100	317.2	116	396.0	131	481.6	147	586.8
39	115.8	55	155.5	70	200.6	86	258.0	101	321.8	117	401.3	132	487.8	148	593.8
40	118.0	56	158.2	71	203.9	87	262.0	102	326.4	118	406.7	133	494.0	149	601.0
41	120.3	57	161.0	72	207.2	88	266.0	103	331.0	119	412.2	134	500.2	150	608.1
42	122.6	58	163.9	73	210.6	89	270.0	104	335.7	120	417.7	135	506.5	151	615.4
43	125.0	59	166.7	74	214.0	90	274.1	105	340.5	121	423.2	136	512.9	152	622.7
44	127.3	60	169.6	75	217.4	91	278.2	106	345.3	122	428.8	137	519.3	153	630.1
45	129.7	61	172.6	76	220.9	92	282.3	107	350.1	123	434.5	138	525.8	154	637.5
46	132.2	62	175.4	77	224.4	93	286.5	108	355.0	124	440.2	139	532.4	155	645.0
47	134.6			78	228.0			109	360.0			140	539.0		

System Operation

⚠ IMPORTANT

Some scroll compressor have internal vacuum protector that will unload scrolls when suction pressure goes below 20 psig. A hissing sound will be heard when the compressor is running unloaded. Protector will reset when low pressure in system is raised above 40 psig. **DO NOT REPLACE COMPRESSOR.**

HIGH PRESSURE SWITCH (S4)

TSA*S4 units are equipped with a high-pressure switch that is located in the liquid line of the compressor as illustrated in figure 1 on page 2.

The switch is a Single Pole, Single Throw (SPST), manual-reset switch which is normally closed and removes power from the compressor when discharge pressure rises above factory setting at 590 ± 10 psi. The manual-reset button can be identified by a red cap that is press to preform the reset function.

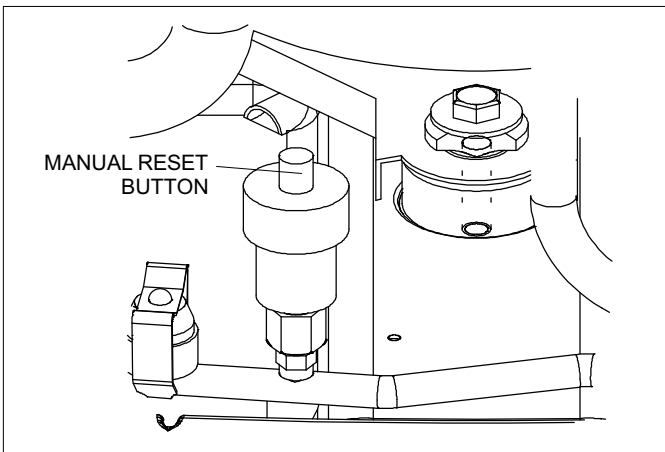

Figure 23. High Pressure Switch (S4) Manual Reset

CRANKCASE HEATER (HR1) AND THERMOSTAT SWITCH (S40) — Y VOLTAGE UNITS ONLY

All models sizes are equipped with a belly band type crankcase heater. HR1 prevents liquid from accumulating in the compressor. On Y voltage units, the HR1 is controlled by a single pole, single throw thermostat switch (S40) located on the liquid line (see figure 1 for location). On all other units, the heater is on when there is no compressor operation.

Maintenance

DEALER

Maintenance and service must be performed by a qualified installer or service agency. At the beginning of each cooling season, the system should be checked as follows:

Outdoor Unit

1. Outdoor unit fan motor is pre-lubricated and sealed. No further lubrication is needed.
2. Visually inspect all connecting lines, joints and coils for evidence of oil leaks.
3. Check all wiring for loose connections.
4. Check for correct voltage at unit (unit operating).
5. Check amp draw on outdoor fan motor.

Motor Nameplate: _____ **Actual:** _____.

6. Inspect drain holes in coil compartment base and clean if necessary.

NOTE - If insufficient cooling occurs, the unit should be gauged and refrigerant charge should be checked.

Outdoor Coil

Clean and inspect outdoor coil (may be flushed with a water hose). Ensure power is off before cleaning.

NOTE — It may be necessary to flush the outdoor coil more frequently if it is exposed to substances which are corrosive or which block airflow across the coil (e.g., pet urine, cottonwood seeds, fertilizers, fluids that may contain high levels of corrosive chemicals such as salts)

Sea Coast — Moist air in ocean locations can carry salt, which is corrosive to most metal. Units that are located near the ocean require frequent inspections and maintenance. These inspections will determine the

necessary need to wash the unit including the outdoor coil. Consult your installing contractor for proper intervals/procedures for your geographic area or service contract.

Indoor Unit

1. Clean or change filters.
2. Lennox blower motors are prelubricated and permanently sealed. No more lubrication is needed.
3. Adjust blower speed for cooling. Measure the pressure drop over the coil to determine the correct blower CFM. Refer to the unit information service manual for pressure drop tables and procedure.
4. *Belt Drive Blowers* - Check belt for wear and proper tension.
5. Check all wiring for loose connections.
6. Check for correct voltage at unit. (blower operating)
7. Check amp draw on blower motor.

Motor Nameplate: _____ **Actual:** _____.

Indoor Coil

1. Clean coil if necessary.
2. Check connecting lines, joints and coil for evidence of oil leaks.
3. Check condensate line and clean if necessary.

HOMEOWNER

Cleaning of the outdoor unit's coil should be performed by a trained service technician. Contact your dealer and set up a schedule (preferably twice a year, but at least once a year) to inspect and service your outdoor unit. The following maintenance may be performed by the homeowner.

IMPORTANT

Sprinklers and soaker hoses should not be installed where they could cause prolonged exposure to the outdoor unit by treated water. Prolonged exposure of the unit to treated water (i.e., sprinkler systems, soakers, waste water, etc.) will corrode the surface of steel and aluminum parts and diminish performance and longevity of the unit.

Outdoor Coil

The outdoor unit must be properly maintained to ensure its proper operation.

- Please contact your dealer to schedule proper inspection and maintenance for your equipment.
- Make sure no obstructions restrict airflow to the outdoor unit.
- Grass clippings, leaves, or shrubs crowding the unit can cause the unit to work harder and use more energy.
- Keep shrubbery trimmed away from the unit and periodically check for debris which collects around the unit.

Routine Maintenance

In order to ensure peak performance, your system must be properly maintained. Clogged filters and blocked airflow prevent your unit from operating at its most efficient level.

1. **Air Filter** — Ask your Lennox dealer to show you where your indoor unit's filter is located. It will be either at the indoor unit (installed internal or external to the cabinet) or behind a return air grille in the wall or ceiling. Check the filter monthly and clean or replace it as needed.

2. **Disposable Filter** — Disposable filters should be replaced with a filter of the same type and size.

NOTE — If you are unsure about the filter required for your system, call your Lennox dealer for assistance.

3. **Reusable Filter** — Many indoor units are equipped with reusable foam filters. Clean foam filters with a mild soap and water solution; rinse thoroughly; allow filter to dry completely before returning it to the unit or grille.

NOTE — The filter and all access panels must be in place any time the unit is in operation.

4. **Lennox Branded Air Filters** — are designed to remove airborne particles from the air passing through the filter.

5. **Indoor Unit** — The indoor unit's evaporator coil is equipped with a drain pan to collect condensate formed as your system removes humidity from the inside air. Have your dealer show you the location of the drain line and how to check for obstructions. (This would also apply to an auxiliary drain, if installed.)

Thermostat Operation

See the thermostat homeowner manual for instructions on how to operate your thermostat.

Preservice Check

If your system fails to operate, check the following before calling for service:

- Verify room thermostat settings are correct.
- Verify that all electrical disconnect switches are ON.
- Check for any blown fuses or tripped circuit breakers.
- Verify unit access panels are in place.
- Verify air filter is clean.
- If service is needed, locate and write down the unit model number and have it handy before calling.

Accessories

For update-to-date information, see any of the following publications:

- Lennox TSA*S4 Engineering Handbook
- Lennox Product Catalog
- Lennox Price Book

Cleaning Outdoor Coil

1. Make sure power is off before cleaning. Clean and inspect outdoor coil. The coil may be flushed with a water hose.
2. The outdoor coil is protected by an inner mesh screen and a wire cage (see figure 24). If debris has collected between the mesh screen and the coil and cannot be dislodged by spraying unpressurized water from

inside coil surface to the outside, the mesh may be removed by first removing the top of the unit which will allow for removal of the wire cage.

3. Then, using pliers to grip the head of the push pins, pull straight out to extract the push pins along one side of the coil. If necessary, remove the push pins along the back of the unit; it is usually unnecessary to fully remove the inner mesh screen.
4. Drape the mesh screen back and wash the coil. When all the debris has been removed from the coil, reinstall the mesh screen by positioning it in its original position and reinserting the push pin. No tool is required to push the pin back into the same slot in the fins.
5. If the push pin is loose and tends not to stay in place, brush the fins with a fin brush (22 fins/in). Line up the push pin a couple fins to the right or left of the original hole and re-insert the pin.

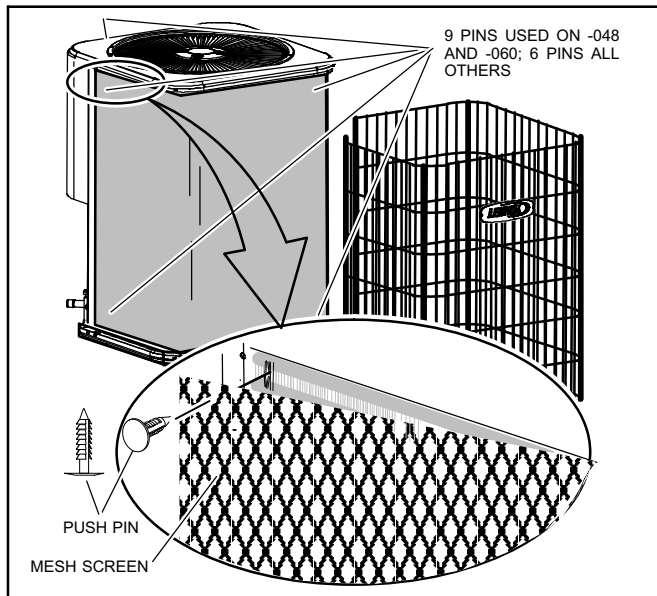

Figure 24. Cleaning Debris from Mesh

Start-Up and Performance Checklist		
Job Name _____	Job no. _____	Date _____
Job Location _____	City _____	State _____
Installer _____	City _____	State _____
Unit Model No. _____	Serial No. _____	Service Technician _____
Nameplate Voltage _____		
Rated Load Ampacity _____	Compressor _____	Outdoor Fan _____
Maximum Fuse or Circuit Breaker _____		
Electrical Connections Tight? <input type="checkbox"/>	Indoor Filter clean? <input type="checkbox"/>	Supply Voltage (Unit Off) _____
Indoor Blower RPM _____	S.P. Drop Over Indoor (Dry) _____	Outdoor Coil Entering Air Temp. _____
Discharge Pressure _____	Suction Pressure _____	Refrigerant Charge Checked? <input type="checkbox"/>
Refrigerant Lines: - Leak Checked? <input type="checkbox"/>	Properly Insulated? <input type="checkbox"/>	Outdoor Fan Checked? <input type="checkbox"/>
Service Valves: --- Fully Opened? <input type="checkbox"/>	Caps Tight? <input type="checkbox"/>	Thermostat
Voltage With Compressor Operating _____	Calibrated? <input type="checkbox"/>	Properly Set? <input type="checkbox"/> Level? <input type="checkbox"/>