

PARTS MANUAL

MODEL
Parts
Manual

EH650DC7160

01/13



SUBARU

Industrial Power Products

Subaru Industrial Power Products

905 Telser Road - Lake Zurich, IL 60047 - Phone 847-540-7300 - Fax 847-438-5012

e-mail: sales@subarupower.com - www.subarupower.com

© 2012 Subaru Industrial Power Products

Group Index

Group Name	Page
100 Crankcase.....	4
200 Crankshaft.....	8
300 Intake & Exhaust.....	10
315 Intake & Exhaust.....	12
400 Governor.....	14
500 Cooling & Starting.....	16
600 Fuel & Lubricant.....	18
640 Fuel & Lubricant.....	20
730 Electric Device.....	22
Part Number Index.....	24
Part Description Index.....	25

100 Crankcase

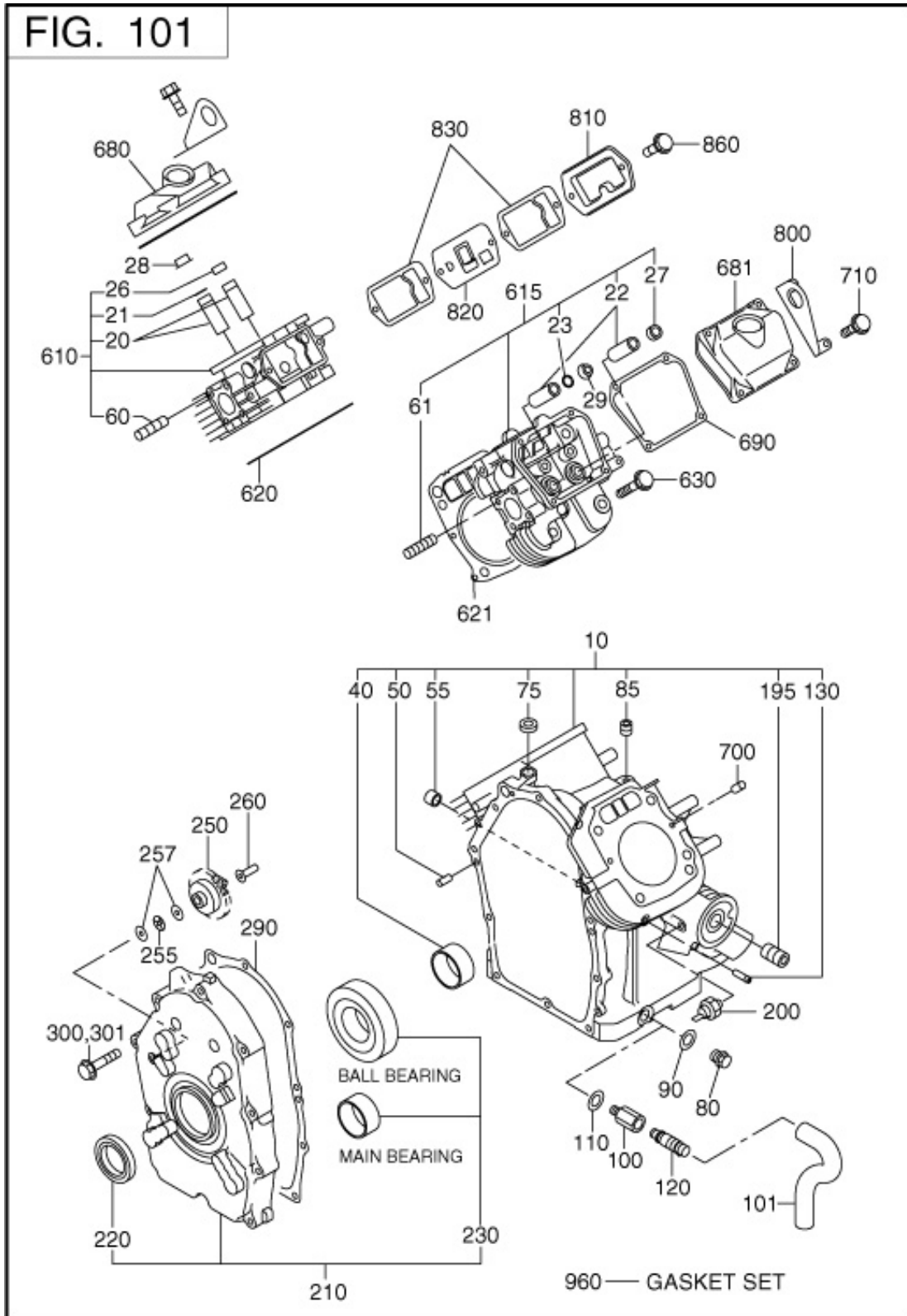

EH65/64/63

263010001W00

100 Crankcase

Ref	Part Number.	Description	Qty	Remark
10	263-10111-21	CRANK CASE CP	1	
20	263-14211-03	VALVE GUIDE	2	
21	056-51000-50	CLIP	1	
22	263-14211-03	VALVE GUIDE	2	
23	056-51000-50	CLIP	1	
26	132-07AA0-50	SEAL-INT VALVE	1	
27	132-07AA0-50	SEAL-INT VALVE	1	
28	263-35341-03	RETAINER PLATE	1	
29	263-35341-03	RETAINER PLATE	1	
40	263-15802-03	MAIN BEARING	1	
50	031-00801-10	DOWEL PIN	2	
55	263-55601-03	PIPE	2	
60	010-50802-90	STUD	4	
61	010-50802-90	STUD	4	
75	044-00800-10	OIL SEAL	1	
80	040-11400-30	PLUG	2	
85	235-15421-03	BLIND PLUG	1	
90	021-11400-20	GASKET	2	
130	159-65401-03	PIPE(PULSE)	1	
195	263-15901-03	UNION	1	
200	263-76102-H1	SWITCH OIL PRESSURE	1	
210	263-11002-51	MAINBEARING COVER CP	1	
220	044-04200-30	OIL SEAL	1	
230	X60-04500-20	BALL BEARING	1	
250	263-45003-11	GOVERNOR GEAR CP	1	
255	263-46215-A3	THRUST BEARING	1	
257	263-46214-03	WASHER	2	
260	277-41901-03	GOVERNOR SLEEVE	1	
290	263-16002-A3	GASKET (M.B COVER)	1	
300	011-00802-20	FLANGE BOLT	10	
610	263-13211-11	CYLINDER HEAD 1 CP	1	
615	263-13311-01	CYLINDER HEAD 2 CP	1	
620	263-15021-41	GASKET 1 (CYL HEAD)	1	
621	263-15121-31	GASKET 2 (CYL HEAD)	1	
630	011-01000-70	FLANGE BOLT	8	
680	263-15505-03	ROCKER COVER	1	
681	263-15503-03	ROCKER COVER	1	
690	263-16101-A3	GASKET(ROCKER COVER)	2	
700	031-00600-20	DOWEL PIN	4	

100 Crankcase

Ref	Part Number.	Description	Qty	Remark
710	011-00601-01	FLANGE BOLT	8	
800	280-19001-03	HOOK	2	
810	263-14301-03	BREATHER COVER	1	
820	280-14401-A1	BREATHER PLATE CP	1	
830	263-16006-03	GASKET(BREATHERPLATE	2	
860	011-00600-30	FLANGE BOLT	2	
960	263-99001-37	GASKET SET	1	

This Page Intentionally Left Blank

200 Crankshaft

FIG. 200

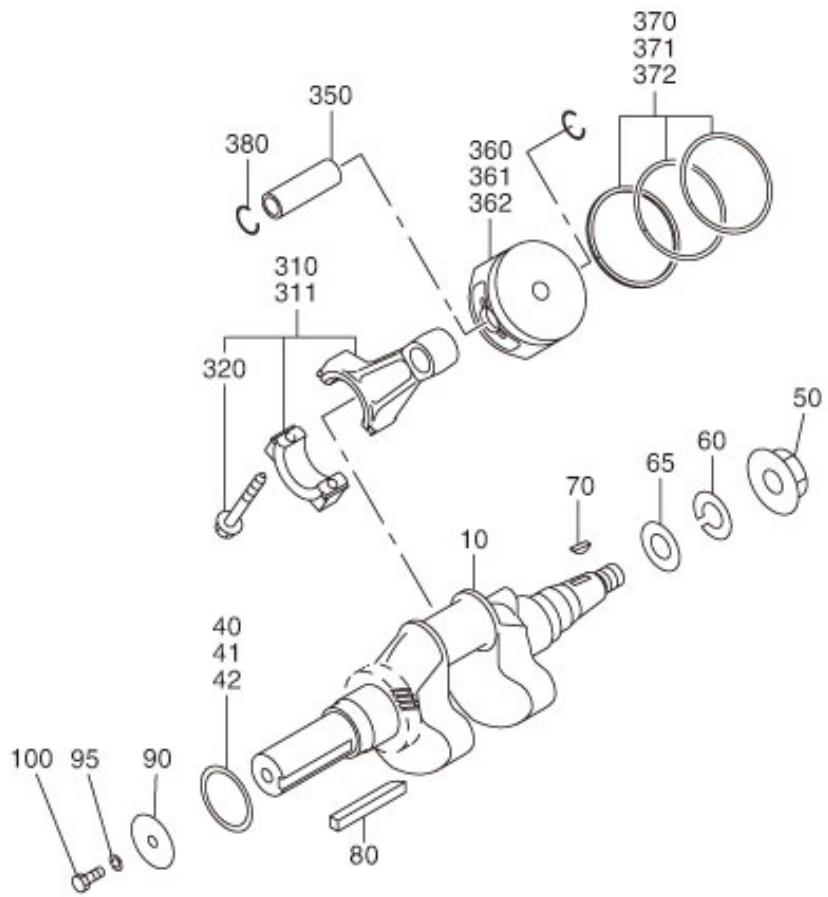

EH65/64/63

263020000W01

200 Crankshaft

Ref	Part Number.	Description	Qty	Remark
10	263-20922-11	CRANK SHAFT CP	1	
40	263-25012-A3	SPACER	1	
41	263-25013-A3	SPACER	1	
42	263-25014-A3	SPACER	1	
50	018-01800-10	FLANGE NUT	1	
65	003-10180-00	WASHER	1	
70	005-32054-01	WOODRUFF KEY	1	
310	263-22601-30	CONNECTING ROD AY	2	
320	001-05084-00	FLANGE BOLT	4	
350	263-23301-33	PISTON PIN	2	
360	263-23421-J3	PISTON	2	
361	263-23422-J3	PISTON	2	
362	263-23423-J3	PISTON	2	
370	263-23501-17	PISTON RING SET	2	
371	263-23502-17	PISTON RING SET	2	
372	263-23503-17	PISTON RING SET	2	
380	056-52100-20	CLIP	4	

300 Intake & Exhaust

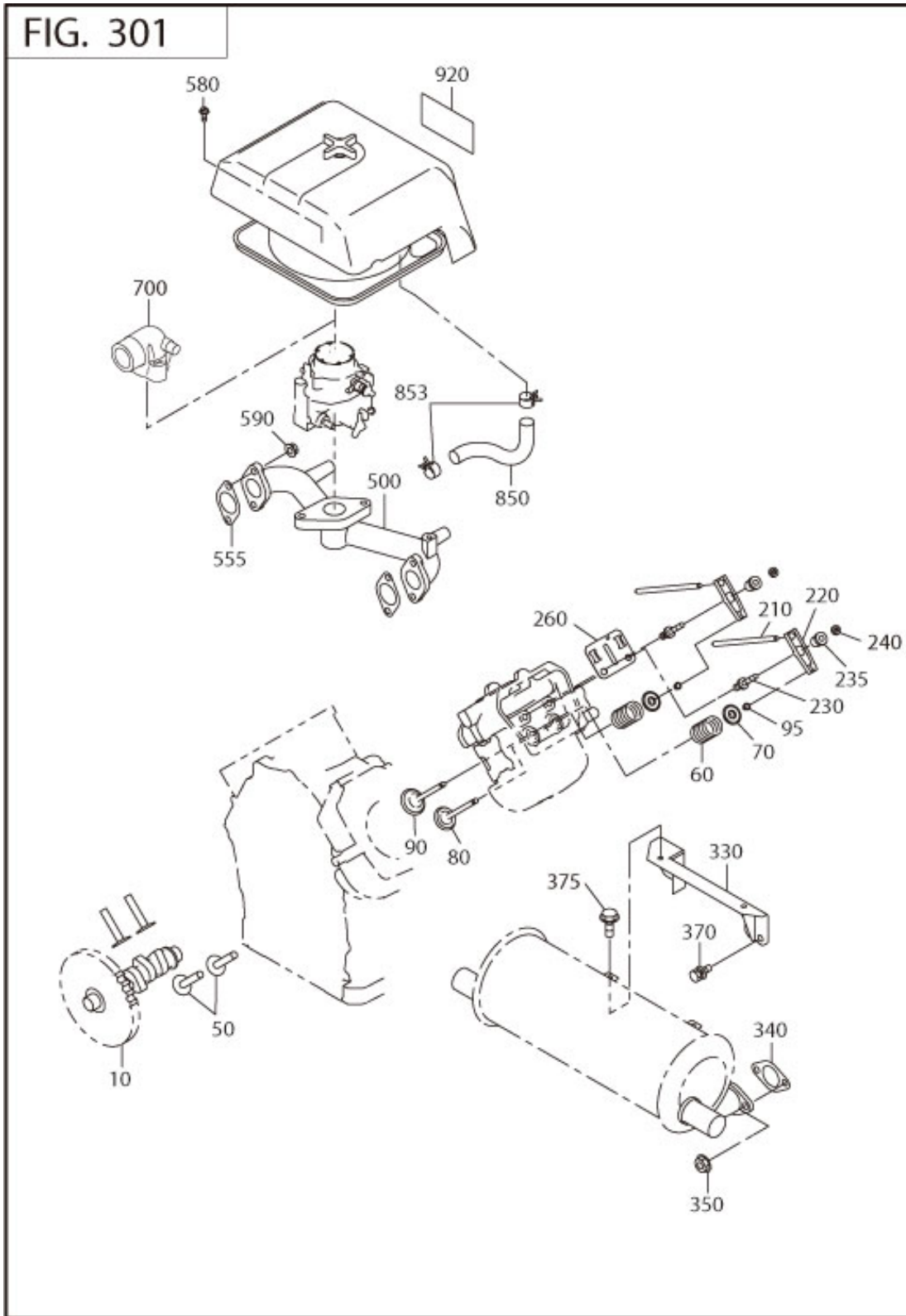

EH65/64/63

263030000W02

300 Intake & Exhaust

Ref	Part Number.	Description	Qty	Remark
10	280-31701-13	CAM SHAFT	1	
50	263-33301-A3	TAPPET	4	
60	246-33611-03	VALVE SPRING	4	
70	246-33711-13	SPRING RETAINER	4	
80	263-33401-H3	INTAKE VALVE	2	
90	263-33502-H3	EXHAUST VALVE	2	
95	246-35501-03	COLLET-VALVE	8	
210	263-35322-A1	PUSH ROD CP	4	
220	267-36102-03	ROCKER ARM	4	
230	263-35801-03	BOLT(PIVOT)	4	
235	267-35701-03	PIVOT	4	
240	017-00601-10	NUT	4	
260	263-37002-A3	GUIDE PLATE	2	
500	280-33005-H3	INTAKE MANIFOLD	1	
555	263-35503-A3	GASKET(IN MANIFOLD)	2	
580	X11-00600-20	FLANGE BOLT	3	
590	002-38080-00	FLANGE NUT	4	
850	263-18003-03	RUBBER PIPE	1	
853	263-68512-A3	HOSE CLAMP	2	
920	263-91721-03	LABEL(TRADE MARK)	1	

315 Intake & Exhaust

FIG. 315

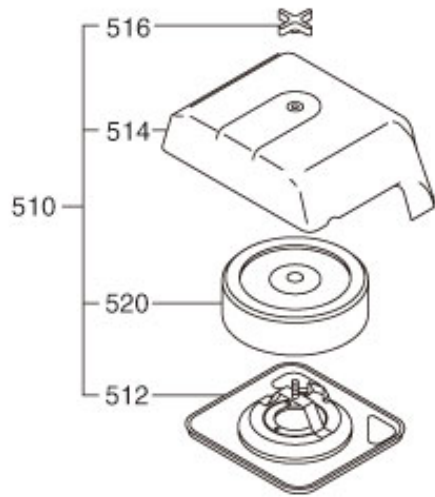

EH65/64/63

263031500W01

315 Intake & Exhaust

Ref	Part Number.	Description	Qty	Remark
510	20K-32601-A0	AIR CLEANER AY	1	
512	280-32626-A1	CLEANER BASE CP	1	
514	263-32630-03	CLEANER COVER	1	
516	263-32640-01	WING NUT	1	
520	263-32610-A1	CLEANER ELEMENT CP	1	

400 Governor

Ref	Part Number.	Description	Qty	Remark
10	263-42301-B3	GOVERNOR LEVER	1	
20	263-42201-A3	GOVERNOR SHAFT	1	
25	X23-00801-50	SPACER	1	
26	003-10080-00	WASHER	2	
30	20K-42701-03	GOVERNOR ROD	1	
40	20K-42801-03	ROD SPRING	1	
50	005-11060-01	SNAP PIN	1	
60	001-14063-00	BOLT AND WASHER AY	1	
70	018-60600-20	NUT	1	
80	263-42501-13	GOVERNOR SPRING	1	
130	280-46011-03	CHOKE CONTROL ROD	1	
140	261-45201-13	RETURN SPRING	2	
145	263-45030-03	SPRING(CONTROL)	1	
170	263-46021-B3	CHOKE LEVER	1	
180	226-43101-01	LINK PIVOT	1	
185	003-22100-00	WAVED WASHER	1	
190	263-43901-A3	CHOKE KNOB	1	
195	263-46010-03	CLAMP(CHOKE KNOB)	1	
197	X15-20500-10	TAPPING SCREW	1	
310	263-43312-A3	SPEED CONTROL LEVER	1	
315	263-47001-A3	BRACKET,RETURN SP	1	
340	227-43501-13	STOP PLATE	1	
350	263-45002-03	SPRING WASHER	1	
355	261-45301-03	SPACER	1	
360	011-50500-20	BOLT	2	
370	002-27050-00	NUT	2	
381	002-38060-00	FLANGE NUT	1	
395	261-43901-03	CLAMP	2	
396	001-17052-00	BOLT & WASHER AY	2	
435	263-45021-A2	BRACKET(SPD CONTROL)	1	
485	011-00600-20	FLANGE BOLT	3	

500 Cooling & Starting

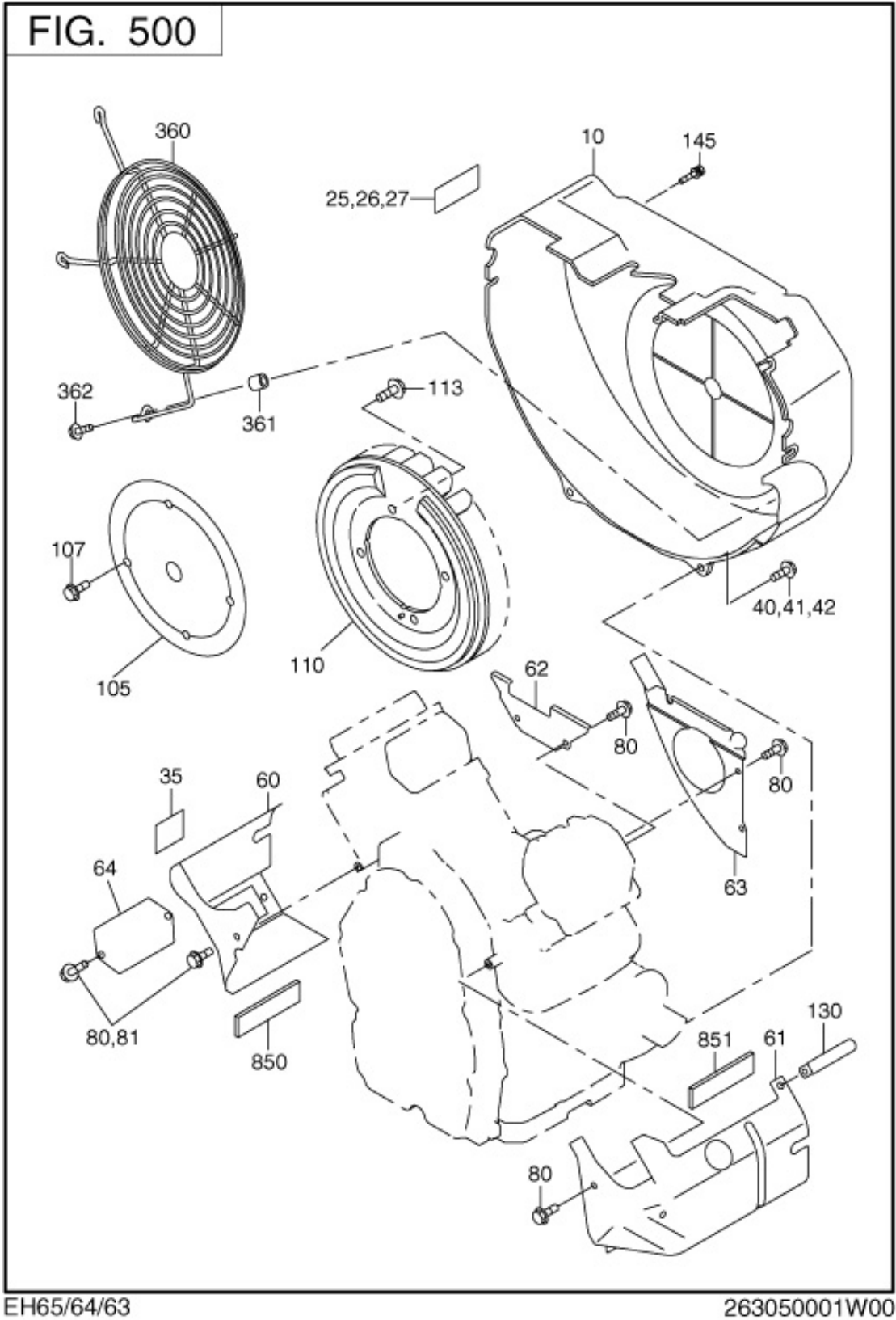

500 Cooling & Starting

Ref	Part Number.	Description	Qty	Remark
10	280-51201-A2	BLOWER HOUSING UN	1	
25	073-20044-50	LABEL(CAUTION)	1	
26	X73-20057-60	LABEL(WARNING)	1	
40	011-00600-30	FLANGE BOLT	8	
41	X11-00601-40	FLANGE BOLT	2	
60	263-52612-A1	CYLINDER BAFFLE 1 CP	1	
61	263-52704-A1	CYLINDER BAFFLE 2 CP	1	
62	280-52801-A2	CYLINDER BAFFLE 3	1	
63	263-52912-A2	CYLINDER BAFFLE 4 UN	1	
80	011-00600-20	FLANGE BOLT	8	
110	263-54101-H2	COOLING BLOWER UN	1	
113	001-14061-60	BOLT AND WASHER AY	4	

600 Fuel & Lubricant

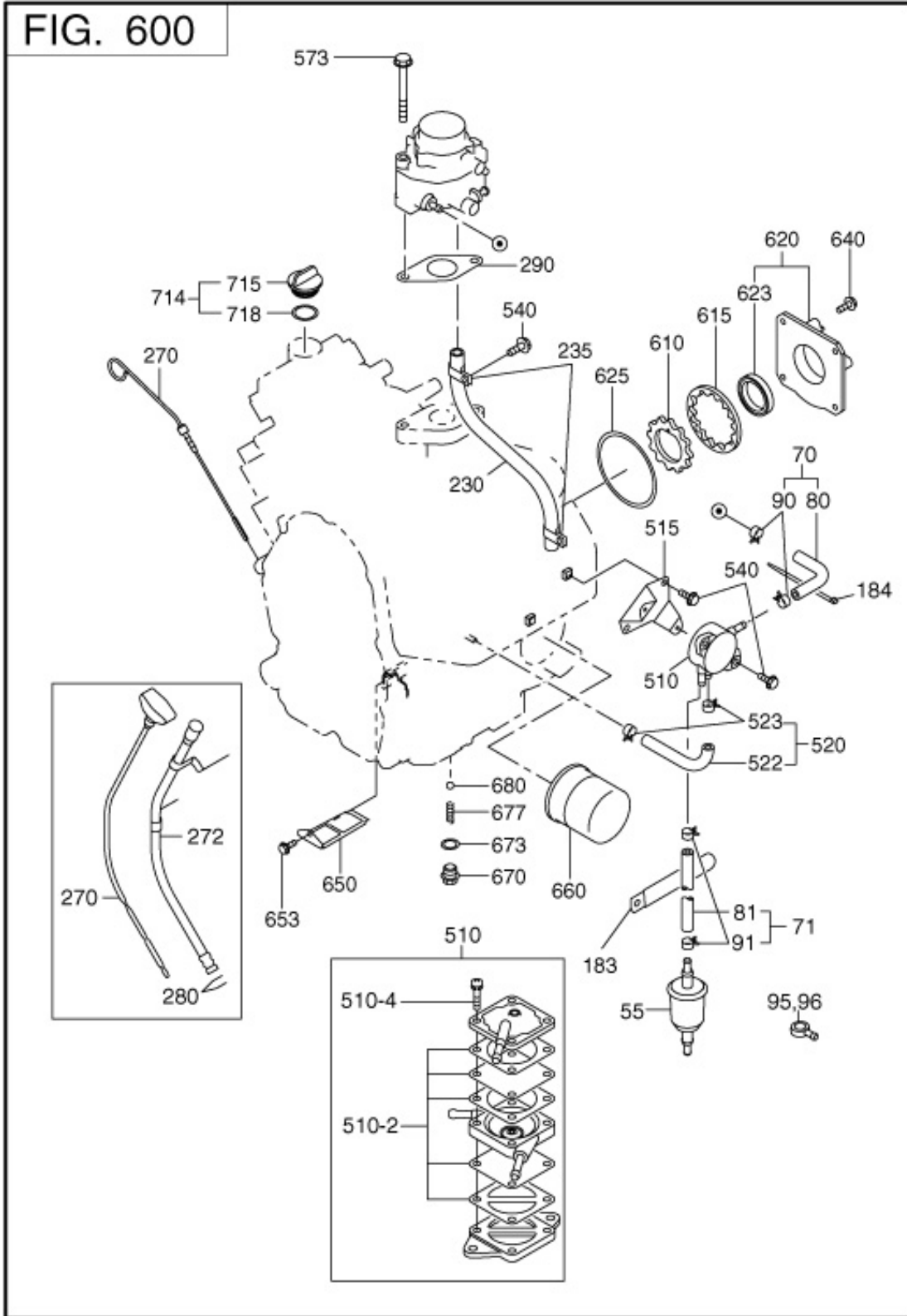

EH65/64/63

263060001W00

600 Fuel & Lubricant

Ref	Part Number.	Description	Qty	Remark
55	263-65012-A3	FILTER,FUEL	1	
80	X85-10616-60	RUBBER PIPE	1	
81	X85-10613-81	RUBBER PIPE	1	
90	263-68501-03	HOSE CLAMP	2	
91	263-68501-03	HOSE CLAMP	2	
230	085-10301-10	RUBBER PIPE	1	
235	206-75501-01	CLAMP CP	2	
270	263-63603-01	OIL GAUGE CP	1	
290	280-66202-03	GASKET(CARBURETOR)	1	
510	267-62201-10	FUEL PUMP AY	1	
515	263-65002-A3	BRACKET(FUEL PUMP)	1	
522	X85-10615-42	RUBBER PIPE	1	
523	263-68501-03	HOSE CLAMP	2	
540	011-00600-20	FLANGE BOLT	5	
573	002-38060-00	FLANGE NUT	4	
610	263-63901-13	INNER ROTOR	1	
615	263-63902-13	OUTER ROTOR	1	
620	263-64002-01	OIL PUMP COVER CP	1	
623	044-03501-70	OIL SEAL	1	
625	X24-08900-30	O RING	1	
640	011-00600-30	FLANGE BOLT	4	
650	263-64302-02	OIL PUMP FILTER UN	1	
653	263-65011-A3	FLANGE BOLT	1	
660	248-65801-00	OIL FILTER AY	1	
670	263-65001-13	PLUG(OIL RELIEF)	1	
673	003-70140-00	GASKET,ALUMINUM	1	
677	263-66001-03	SPRING(RELIEF VALVE)	1	
680	006-90308-00	STEEL BALL	1	
714	280-63602-A1	OIL FILLER CAP CP	1	
718	263-64414-A3	O RING	1	

640 Fuel & Lubricant

FIG. 640

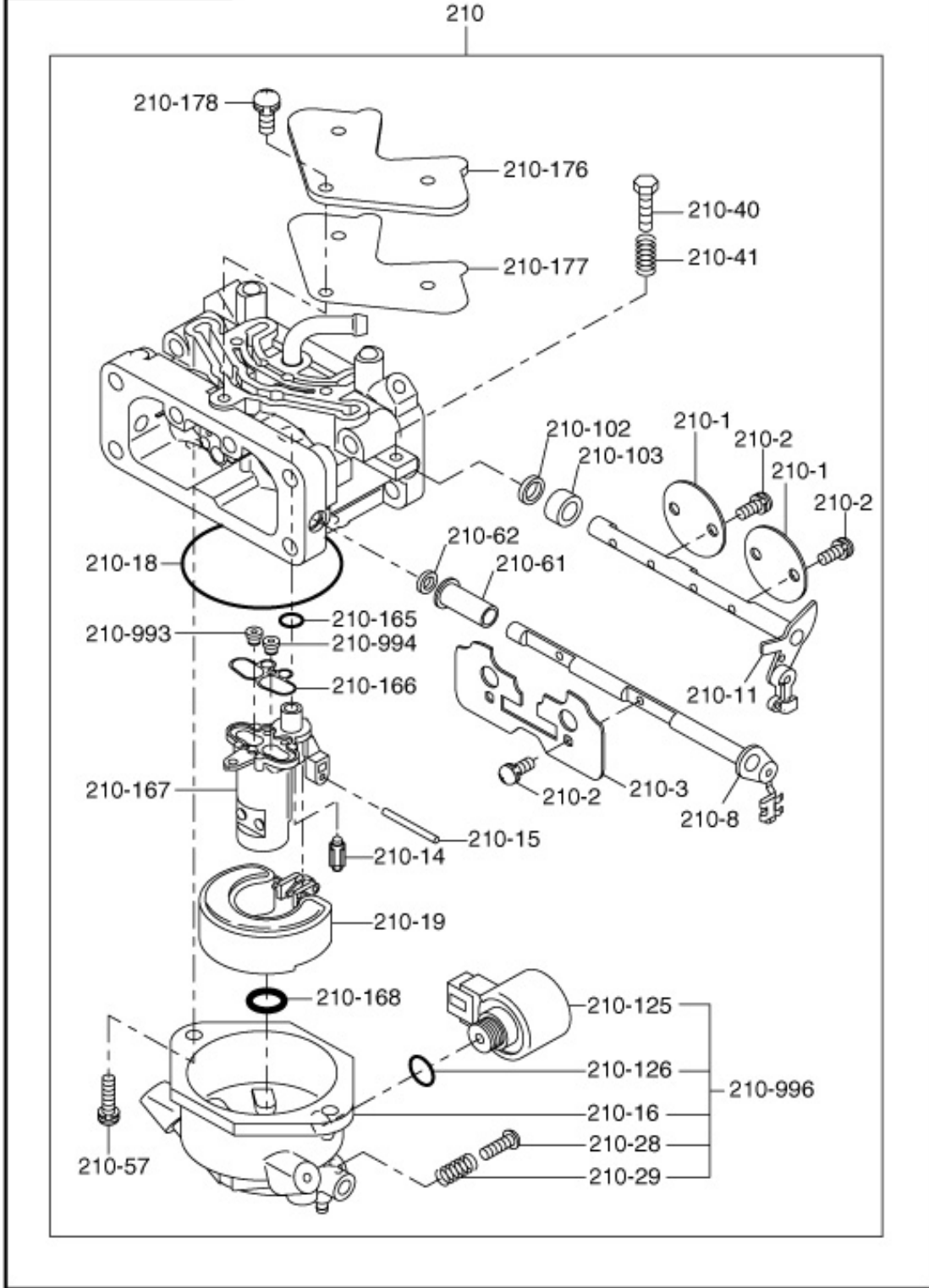

EH722

20K064000W00

640 Fuel & Lubricant

Ref	Part Number.	Description	Qty	Remark
210	263-62494-10	CARBURETOR AY	1	
-1	263-62539-08	VALVE, THROTTLE	2	
-2	258-62555-08	SCREW SET, VALVE	6	
-3	263-62529-08	VALVE, CHOKE	1	
-8	20K-62520-08	SHAFT ASSY, CHOKE	1	
-11	263-62538-08	SHAFT COMPL, THROTTLE	1	
-14	20K-62500-08	VALVE, FLOAT	1	
-15	20K-62515-08	PIN, FLOAT	1	
-16	20K-62556-08	CHAMBER ASSY, FLOAT	1	
-18	20K-62540-08	GASKET, FLOAT CHAMBER	1	
-19	263-62505-08	FLOAT	1	
-28	215-62353-08	SCREW, DRAIN	1	
-29	215-62446-08	SPRING, DRAIN	1	
-40	20K-62553-08	SCREW, THROTTLE ADJUST	1	
-41	258-62445-08	SPRING, ADJUST SCREW	1	
-57	20B-62453-08	SCREW, CHAMBER SET	2	
-61	20K-62560-08	COLLAR, CHOKE	1	
-62	263-62574-08	SEAL, THROTTLE SHAFT	1	
-102	20K-62550-08	SEAL, THROTTLE	1	
-103	20K-62561-08	COLLAR, THROTTLE	1	
-125	20K-62557-08	VALVE COMPL, SOLENOID	1	
-126	20B-62556-08	GASKET	1	
-165	20B-62541-08	O RING	1	
-166	20K-62541-08	GASKET, SPACER	1	
-167	20K-62554-08	SPACER, CARB	1	
-168	20B-62542-08	O RING	1	
-176	20K-62559-08	COVER, SLOW PASSAGE	1	
-177	20K-62558-08	GASKET, SLOW PASSAGE	1	
-178	107-62462-08	SCREW	3	
-993	20B-62430-08	JET COMPL, MAIN (L)	1	
-994	20B-62433-08	JET COMPL, MAIN (R)	1	
-996	20K-62555-08	CHAMBER COMPL, FLOAT	1	

730 Electric Device

FIG. 731

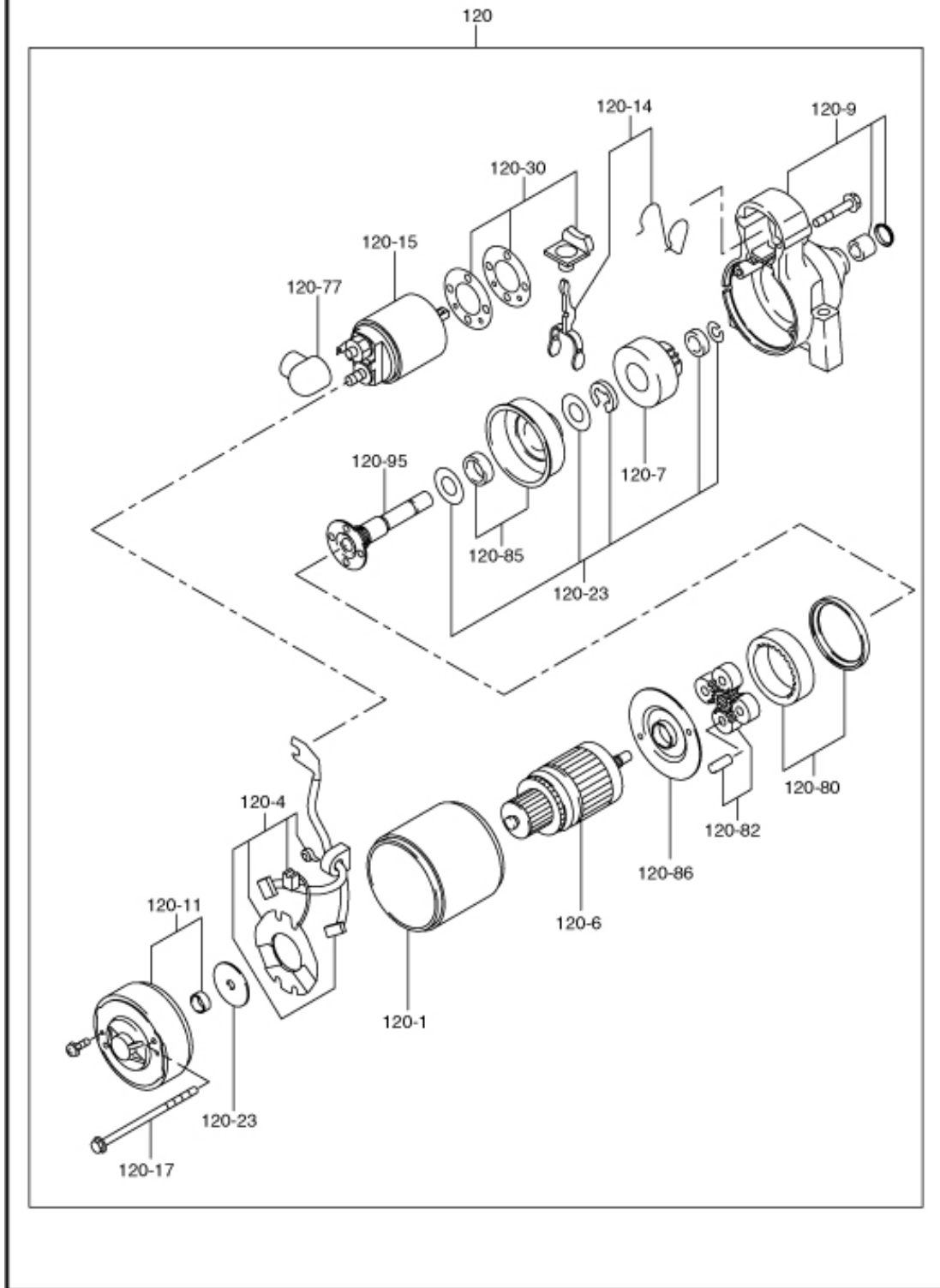

EH65/64/63

263073100W00

730 Electric Device

Ref	Part Number.	Description	Qty	Remark
120	263-70504-H0	STARTING MOTOR AY	1	
-1	263-70561-08	YOKE AY	1	
-4	245-70503-08	BRUSH HOLDER AY	1	
-6	263-70512-08	ARMATURE AY	1	
-7	263-70522-08	PINION AY	1	
-9	263-70503-08	GEAR CASE AY	1	
-11	263-70507-08	REAR COVER AY	1	
-14	245-70518-08	SHIFT LEVER SET	1	
-15	263-70515-08	MAGNETIC SWITCH AY	1	
-17	207-70524-08	THROUGH BOLT	2	
-23	245-70516-08	WASHER STOPPER SET	1	
-30	245-70520-08	DUST COVER KIT	1	
-77	207-70526-08	RUBBER CAP BS	1	
-80	263-70596-08	INTERNAL GEAR	1	
-82	263-70576-08	PLANET GEAR	3	
-85	245-70509-08	CENTER BRACKET(P)	1	
-86	263-70591-08	CENTER BRACKET (A)	1	
-95	263-70571-08	PINION SHAFT	1	

Part Number Index

The Part Number Index is a numeric index of all part numbers included in this manual. The index shows what page(s) the part is used on.

Part Number	Page	Part Number	Page	Part Number	Page
001-05084-00	9	226-43101-01	15	263-46214-03	5
001-14061-60	17	227-43501-13	15	263-46215-A3	5
001-14063-00	15	235-15421-03	5	263-47001-A3	15
001-17052-00	15	245-70503-08	23	263-52612-A1	17
002-27050-00	15	245-70509-08	23	263-52704-A1	17
002-38060-00	15, 19	245-70516-08	23	263-52912-A2	17
002-38080-00	11	245-70518-08	23	263-54101-H2	17
003-10080-00	15	245-70520-08	23	263-55601-03	5
003-10180-00	9	246-33611-03	11	263-62494-10	21
003-22100-00	15	246-33711-13	11	263-62505-08	21
003-70140-00	19	246-35501-03	11	263-62529-08	21
005-11060-01	15	248-65801-00	19	263-62538-08	21
005-32054-01	9	258-62445-08	21	263-62539-08	21
006-90308-00	19	258-62555-08	21	263-62574-08	21
010-50802-90	5	261-43901-03	15	263-63603-01	19
011-00600-20	15, 17, 19	261-45201-13	15	263-63901-13	19
011-00600-30	6, 17, 19	261-45301-03	15	263-63902-13	19
011-00601-01	6	263-10111-21	5	263-64002-01	19
011-00802-20	5	263-11002-51	5	263-64302-02	19
011-01000-70	5	263-13211-11	5	263-64414-A3	19
011-50500-20	15	263-13311-01	5	263-65001-13	19
017-00601-10	11	263-14211-03	5	263-65002-A3	19
018-01800-10	9	263-14301-03	6	263-65011-A3	19
018-60600-20	15	263-15021-41	5	263-65012-A3	19
021-11400-20	5	263-15121-31	5	263-66001-03	19
031-00600-20	5	263-15503-03	5	263-68501-03	19
031-00801-10	5	263-15505-03	5	263-68512-A3	11
040-11400-30	5	263-15802-03	5	263-70503-08	23
044-00800-10	5	263-15901-03	5	263-70504-H0	23
044-03501-70	19	263-16002-A3	5	263-70507-08	23
044-04200-30	5	263-16006-03	6	263-70512-08	23
056-51000-50	5	263-16101-A3	5	263-70515-08	23
056-52100-20	9	263-18003-03	11	263-70522-08	23
073-20044-50	17	263-20922-11	9	263-70561-08	23
085-10301-10	19	263-22601-30	9	263-70571-08	23
107-62462-08	21	263-23301-33	9	263-70576-08	23
132-07AA0-50	5	263-23421-J3	9	263-70591-08	23
159-65401-03	5	263-23422-J3	9	263-70596-08	23
206-75501-01	19	263-23423-J3	9	263-76102-H1	5
207-70524-08	23	263-23501-17	9	263-91721-03	11
207-70526-08	23	263-23502-17	9	263-99001-37	6
20B-62430-08	21	263-23503-17	9	267-35701-03	11
20B-62433-08	21	263-25012-A3	9	267-36102-03	11
20B-62453-08	21	263-25013-A3	9	267-62201-10	19
20B-62541-08	21	263-25014-A3	9	277-41901-03	5
20B-62542-08	21	263-32610-A1	13	280-14401-A1	6
20B-62556-08	21	263-32630-03	13	280-19001-03	6
20K-32601-A0	13	263-32640-01	13	280-31701-13	11
20K-42701-03	15	263-33301-A3	11	280-32626-A1	13
20K-42801-03	15	263-33401-H3	11	280-33005-H3	11
20K-62500-08	21	263-33502-H3	11	280-46011-03	15
20K-62515-08	21	263-35322-A1	11	280-51201-A2	17
20K-62520-08	21	263-35341-03	5	280-52801-A2	17
20K-62540-08	21	263-35503-A3	11	280-63602-A1	19
20K-62541-08	21	263-35801-03	11	280-66202-03	19
20K-62550-08	21	263-37002-A3	11	X11-00600-20	11
20K-62553-08	21	263-42201-A3	15	X11-00601-40	17
20K-62554-08	21	263-42301-B3	15	X15-20500-10	15
20K-62555-08	21	263-42501-13	15	X23-00801-50	15
20K-62556-08	21	263-43312-A3	15	X24-08900-30	19
20K-62557-08	21	263-43901-A3	15	X60-04500-20	5
20K-62558-08	21	263-45002-03	15	X73-20057-60	17
20K-62559-08	21	263-45003-11	5	X85-10613-81	19
20K-62560-08	21	263-45021-A2	15	X85-10615-42	19
20K-62561-08	21	263-45030-03	15	X85-10616-60	19
215-62353-08	21	263-46010-03	15		
215-62446-08	21	263-46021-B3	15		

Part Description Index

The Part Description Index is an alphabetical index of all part descriptions included in this manual. The index shows what page(s) the part is used on.

A
 AIR CLEANER AY.....13
 ARMATURE AY.....23

B
 BALL BEARING.....5
 BLIND PLUG.....5
 BLOWER HOUSING UN.....17
 BOLT.....15
 BOLT & WASHER AY.....15
 BOLT AND WASHER AY.....15, 17
 BOLT(PIVOT).....11
 BRACKET(FUEL PUMP).....19
 BRACKET(SPD CONTROL).....15
 BRACKET,RETURN SP.....15
 BREATHER COVER.....6
 BREATHER PLATE CP.....6
 BRUSH HOLDER AY.....23

C
 CAM SHAFT.....11
 CARBURETOR AY.....21
 CENTER BRACKET (A).....23
 CENTER BRACKET(P).....23
 CHAMBER ASSY, FLOAT.....21
 CHAMBER COMPL, FLOAT.....21
 CHOKE CONTROL ROD.....15
 CHOKE KNOB.....15
 CHOKE LEVER.....15
 CLAMP.....15
 CLAMP CP.....19
 CLAMP(CHOKE KNOB).....15
 CLEANER BASE CP.....13
 CLEANER COVER.....13
 CLEANER ELEMENT CP.....13
 CLIP.....5, 9
 COLLAR, CHOKE.....21
 COLLAR, THROTTLE.....21
 COLLET-VALVE.....11
 CONNECTING ROD AY.....9
 COOLING BLOWER UN.....17
 COVER, SLOW PASSAGE.....21
 CRANK CASE CP.....5
 CRANK SHAFT CP.....9
 CYLINDER BAFFLE 1 CP.....17
 CYLINDER BAFFLE 2 CP.....17
 CYLINDER BAFFLE 3.....17
 CYLINDER BAFFLE 4 UN.....17
 CYLINDER HEAD 1 CP.....5
 CYLINDER HEAD 2 CP.....5

D
 DOWEL PIN.....5
 DUST COVER KIT.....23

E
 EXHAUST VALVE.....11

F
 FILTER,FUEL.....19
 FLANGE BOLT.....5-6, 9, 11, 15, 17, 19
 FLANGE NUT.....9, 11, 15, 19
 FLOAT.....21
 FUEL PUMP AY.....19

G
 GASKET.....5, 21
 GASKET (M.B COVER).....5
 GASKET 1 (CYL HEAD).....5
 GASKET 2 (CYL HEAD).....5
 GASKET SET.....6
 GASKET(BREATHERPLATE).....6
 GASKET(CARBURETOR).....19
 GASKET(IN MANIFOLD).....11
 GASKET(ROCKER COVER).....5
 GASKET, FLOAT CHAMBER.....21
 GASKET, SLOW PASSAGE.....21
 GASKET, SPACER.....21
 GASKET,ALUMINUM.....19
 GEAR CASE AY.....23
 GOVERNOR GEAR CP.....5
 GOVERNOR LEVER.....15
 GOVERNOR ROD.....15
 GOVERNOR SHAFT.....15
 GOVERNOR SLEEVE.....5
 GOVERNOR SPRING.....15
 GUIDE PLATE.....11

H
 HOOK.....6
 HOSE CLAMP.....11, 19

I
 INNER ROTOR.....19
 INTAKE MANIFOLD.....11
 INTAKE VALVE.....11
 INTERNAL GEAR.....23

J
 JET COMPL, MAIN (L).....21
 JET COMPL, MAIN (R).....21

L
 LABEL(CAUTION).....17
 LABEL(TRADE MARK).....11
 LABEL(WARNING).....17
 LINK PIVOT.....15

M
 MAGNETIC SWITCH AY.....23

MAIN BEARING.....5
 MAINBEARING COVER CP.....5

N
 NUT.....11, 15

O
 O RING.....19, 21
 OIL FILLER CAP CP.....19
 OIL FILTER AY.....19
 OIL GAUGE CP.....19
 OIL PUMP COVER CP.....19
 OIL PUMP FILTER UN.....19
 OIL SEAL.....5, 19
 OUTER ROTOR.....19

P
 PIN, FLOAT.....21
 PINION AY.....23
 PINION SHAFT.....23
 PIPE.....5
 PIPE(PULSE).....5
 PISTON.....9
 PISTON PIN.....9
 PISTON RING SET.....9
 PIVOT.....11
 PLANET GEAR.....23
 PLUG.....5
 PLUG(OIL RELIEF).....19
 PUSH ROD CP.....11

R
 REAR COVER AY.....23
 RETAINER PLATE.....5
 RETURN SPRING.....15
 ROCKER ARM.....11
 ROCKER COVER.....5
 ROD SPRING.....15
 RUBBER CAP BS.....23
 RUBBER PIPE.....11, 19

S
 SCREW.....21
 SCREW SET, VALVE.....21
 SCREW, CHAMBER SET.....21
 SCREW, DRAIN.....21
 SCREW, THROTTLE ADJUST.....21
 SEAL, THROTTLE SHAFT.....21
 SEAL, THROTTLE.....21
 SEAL-INT VALVE.....5
 SHAFT ASSY, CHOKE.....21
 SHAFT COMPL, THROTTLE.....21
 SHIFT LEVER SET.....23
 SNAP PIN.....15
 SPACER.....9, 15
 SPACER, CARB.....21
 SPEED CONTROL LEVER.....15

Part Description Index (continued)

SPRING RETAINER.....11
SPRING WASHER.....15
SPRING(CONTROL).....15
SPRING(RELIEF VALVE).....19
SPRING, ADJUST SCREW.....21
SPRING, DRAIN.....21
STARTING MOTOR AY.....23
STEEL BALL.....19
STOP PLATE.....15
STUD.....5
SWITCH OIL PRESSURE.....5

T

TAPPET.....11
TAPPING SCREW.....15
THROUGH BOLT.....23
THRUST BEARING.....5

U

UNION.....5

V

VALVE COMPL, SOLENOID.....21
VALVE GUIDE.....5
VALVE SPRING.....11
VALVE, CHOKE.....21
VALVE, FLOAT.....21
VALVE, THROTTLE.....21

W

WASHER.....5, 9, 15
WASHER STOPPER SET.....23
WAVED WASHER.....15
WING NUT.....13
WOODRUFF KEY.....9

Y

YOKE AY.....23

This Page Intentionally Left Blank

PRINTED IN THE USA

Subaru Industrial Power Products

905 Telser Road - Lake Zurich, IL 60047

Phone 847-540-7300 - Fax 847-438-5012

e-mail: sales@subarupower.com - www.subarupower.com