

*Please Read These Instructions
Before Using Your Mower*

Mountfield

Operating Instructions

*for models
HP185 & SP185 Lawnmowers
with B&S 300 Series engine*



Product Codes:
299164623/SF
299264623/SF

**Do not return this product to store, please call
the Service Link Helpline**

**Products with petrol in cannot be accepted
back in store**

Supported by



For all your Warranty,
Parts and Service needs

0800 121 6585

www.servicelink.org.uk

EN ENGLISH (Original instructions)	
- Safety precautions	3-4
- Know your mower	4-6
- How to get mowing	7-9
- Maintenance	9-10
- Fault Finding	10
GUARANTEE	12

Thank you for purchasing a Mountfield lawnmower. This machine will give you many years of safe and reliable service if operated in accordance with these instructions. **Please read and understand these Operating Instructions before using your mower. Failure to do so could result in personal injury or damage to the equipment.**



NEVER TIP THE MOWER ON ITS SIDE AS THIS WILL FLOOD THE AIR FILTER WITH OIL.
To access the underside, lift the front wheels by lowering the handle until it rests on the ground.

SAFETY PRECAUTIONS

Your lawnmower should be used with due care and attention. Symbols have therefore been placed on various parts of the machine to remind you of the main precautions to be taken. Their meaning is explained below. You are also asked to carefully read the safety regulations in the applicable chapter of this handbook



1. **Warning:** Read the instructions manual before using the machine.
2. **Beware of thrown objects:** Keep other people at a safe distance whilst working.
3. **Beware of cutting:** Moving blades. Do not put hands or feet near the blades. Disconnect the spark plug before carrying out any repairs or maintenance.
4. Only for electric lawnmowers.
5. Only for electric lawnmowers.
6. **Warning:** the blade will continue to rotate for a while after you have switched off the lawnmower.

DESCRIPTION OF SYMBOLS ON CONTROLS (where foreseen)



10. Engine stop 11. Drive on

Maximum noise and vibration levels

Operator's ear noise pressure level..... db(A) 81
- Measurement uncertainty db(A) 0,5

Measured acoustic output level..... db(A) 95
- Measurement uncertainty db(A) 0,35

Guaranteed acoustic output level..... db(A) 96

Vibration level m/s 7,72
- Measurement uncertainty m/s 0,9

IDENTIFICATION LABEL

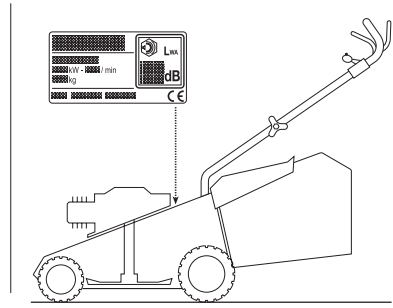
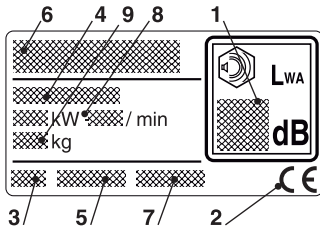

1. Acoustic power level
2. Conformity mark
3. Year of manufacture
4. Type of lawnmower
5. Serial number
6. Name and address of manufacturer
7. Article code
8. Engine power and speed
9. Weight in kilograms

As soon as you have purchased the machine, do not forget to write the identification numbers (3-4-5-7) in the spaces on the last page of the manual.

KNOW YOUR MOWER



The following safety precautions must be observed at all times. Please read them carefully.

TRAINING

- 1) **Read the instructions carefully.** Get familiar with the controls and proper use of the equipment. Learn how to stop the engine quickly
- 2) **Only use the lawnmower for the purpose for which it was designed, i.e. for cutting and collecting grass.** Any other use can be hazardous, causing damage to the machine. Examples of improper use may include, but are not limited to:
 - transport of people, children or animals on the machine;
 - being transported by the machine;
 - using the machine to tow or push loads;
 - using the machine for leaf or debris collection;
 - using the machine to trim hedges, or for cutting vegetation other than grass;
 - use of the machine by more than one person;
 - using the blade on surfaces other than grass.
- 3) Never allow children or people unfamiliar with these instructions to use the lawnmower. Local regulations may restrict the age of the operator.
- 4) **Never use the lawnmower:**
 - When people, especially children, or pets are nearby.
 - If the operator has taken medicine or substances that can affect his ability to react and concentrate.
- 5) Remember that the operator or user is responsible for accidents or hazards occurring to other people or their property.

PREPARATION

- 1) **While mowing, always wear sturdy footwear and long trousers. Do not operate the equipment when barefoot or wearing open sandals.**
- 2) Thoroughly inspect the area where the equipment is to be used and remove all objects which may be thrown by the machine or damage the cutter assembly and the engine (stones, sticks, metal wire, bones, etc.)
- 3) **WARNING: DANGER! Engine fuel is highly flammable:**
 - Store fuel in containers specifically designed for this purpose.
 - **Refuel using a funnel and outdoors only. Do not smoke while refuelling or whenever handling the fuel**
 - Add fuel before starting the engine. Never remove the cap of the fuel tank or add fuel while the engine is running or when the engine is hot.
 - If fuel is spilt, do not attempt to start the engine but move the machine away from the area of spillage and avoid creating any source of ignition until the fuel has evaporated and the vapour dispersed.
 - Replace all fuel tanks and containers caps securely.
- 4) Substitute faulty silencers. Never use the machine without silencer.
- 5) **Before use, always inspect the machine, especially the condition of the blades, and check that the screws and cutting assembly are not worn or damaged.** Replace worn or damaged blades and screws in sets to preserve balance.
- 6) Before mowing, attach the discharge opening guards (grass-catcher or stone-guard).

OPERATION

- 1) Do not operate the engine in a confined space where dangerous carbon monoxide fumes can collect.
- 2) Mow only in daylight or good artificial light.
- 3) If possible, avoid operating the equipment in wet grass.
- 4) Always be sure of your footing on slopes.
- 5) Walk, never run and do not allow yourself to be pulled along by the lawnmower.
- 6) Mow across the face of slopes, never up and down.
- 7) Exercise extreme caution when changing direction on slopes..
- 8) **Do not mow on slopes of more than 20°.**
- 9) Exercise extreme caution when pulling the lawnmower towards you
- 10) Stop the blade if the lawnmower has to be tilted for transportation when crossing surfaces other than grass, and when transporting the lawnmower to and from the area to be mowed.
- 11) Never operate the lawnmower with defective guards, or without safety devices, such as the stone-guard and/or grass-catcher, in place.
- 12) Do not change the engine governor settings or overspeed the engine.

- 13) On power-driven models, disengage the drive clutch before starting the engine.
- 14) Start the engine carefully, following the instructions and keeping feet well away from the blade.
- 15) Do not tilt the lawnmower when starting the engine. Start the engine on a flat surface that is free of obstacles and tall grass.
- 16) **Do not put hands or feet near or under rotating parts.** Keep clear of the discharge opening at all times.
- 17) Never pick up or carry a lawnmower while the engine is running.
- 18) **Stop the engine and disconnect the spark plug wire:**
 - Before carrying out any work underneath the cutting deck or before unclogging the chute;
 - Before checking, cleaning or working on lawnmower;
 - After striking a foreign object. Inspect the lawnmower for damage and make repairs before restarting and operating the lawnmower;
 - If the lawnmower begins to abnormally vibrate immediately look for the cause of the vibrations and take the mower to your local Mountfield Service Dealer.
- 19) **Stop the engine:**
 - Whenever you leave the lawnmower unattended. Remove the key from models with electric starters.
 - Before refuelling.
 - Every time you remove or replace the grass-catcher.
 - Before adjusting the grass cutting height.
- 20) Reduce the throttle before turning off the engine when you have finished mowing, following the instructions in the engine handbook.
- 21) When mowing, always keep to a safe distance from the rotating blade. This distance is the length of the handle.

MAINTENANCE AND STORAGE

- 1) Keep all nuts, bolts and screws tight to be sure the equipment is in safe working condition. Regular maintenance is essential for safety and performance.
- 2) Never store the equipment with fuel in the tank inside a building where vapour may reach a flame or a spark or a source of extreme heat.
- 3) Allow the engine to cool before storing in an enclosed space.
- 4) **To reduce the fire hazard, keep the engine, exhaust silencer, battery compartment and fuel storage area free of grass, leaves, or excessive grease.** Do not leave containers with grass cuttings in rooms.
- 5) Check the stone-guard and grass-catcher frequently for wear and deterioration.
- 6) If the fuel tank has to be drained, this should be done outdoors and when the engine is cool.
- 7) Wear strong work gloves when removing and reassembling the blade.
- 8) **Keep the blade balanced during sharpening.** All operations on the blade (dismantling, sharpening, balancing, remounting and/or replacing) require a certain familiarity and special tools. For safety reasons, these jobs are best carried out at a specialized centre.
- 9) **For safety reasons, never use the machine when it has worn or damaged parts. Parts are to be replaced and not repaired. Use genuine spare parts. Parts that are not of the same quality can damage the equipment and impair your safety.**
- 10) If the machine is not going to be used for 28 days or more please drain all fuel from the machine. Stale fuel can cause damage to the carburettor.

TRANSPORTATION AND HANDLING

- 1) Whenever the machine is to be handled, raised, transported or tilted you must:
 - wear strong working gloves;
 - grasp the machine at the points that offer a safe grip, taking account of the weight and its distribution.
 - use an appropriate number of people for the weight of the machine and the characteristics of the vehicle or the place where it has to be placed or collected.
- 2) During transport, fasten the machine securely with ropes or chains.

HOW TO GET MOWING

Your Mountfield lawnmower does not contain petrol or oil and these must be added before use.

Running the mower with insufficient oil can cause serious damage to the engine and will invalidate your warranty.



NEVER TIP THE MOWER ONTO ITS SIDE AS THIS WILL FLOOD THE AIR FILTER WITH OIL.

To access the underside of the machine lift the front wheels by lowering the handle to the ground.

Carefully remove the mower from the box and read these Operating Instructions. An Owner's Manual for the engine is also included. Please read this before starting the engine.



WARNING - Unpacking and completing the assembly should be done on a flat and stable surface, with enough space for machine handling and its packaging, always making use of suitable equipment. Disposal of the packaging should be done in accordance with the local regulations in force

HANDLE ASSEMBLY (Figure 1)

- Attach the bottom of the handle to the holes on the side of the cutter deck. Secure it using the bolts supplied. An allen key to tighten the nuts is located at the base of the handles.
- Fit the top handle using the nuts & bolts provided.
- Engage the Operator Presence Control (OPC) lever by pulling and holding it against the handle in order to release the engine brake. Pull the starter cord, and fit it into the cord guide as shown. Tighten the nut using a 10mm spanner. Failure to use the cord guide will result in premature cord wear.
- Secure the control cables using the clamp. Take care that the cables are not secured too tightly (this may impair how the mower operates) or impair removal of the grass collector. The clutch cable and control lever are only fitted to models with power drive (SP185).

Figure 1

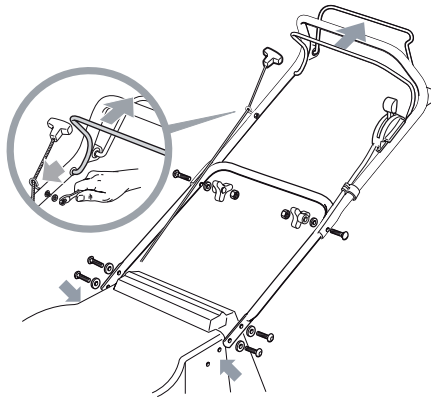

GRASS COLLECTOR (Figure 2)

Fabric grass collector: Fit the fabric bag over the steel frame and then snap the bag onto the plastic lid.

Figure 2

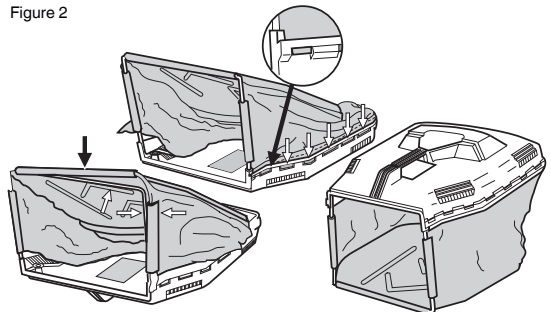

GRASS CUTTING

This machine cuts lawns in various modes; before starting work, prepare the machine based on how the lawn is to be mowed.

MAKE THIS ADJUSTMENT WHEN THE ENGINE IS OFF

HOW TO USE

- 1 "Mulching" – Chopping and depositing grass on the lawn
- 2 Cutting and collecting grass cuttings
- 3 Cutting and ejecting grass cuttings

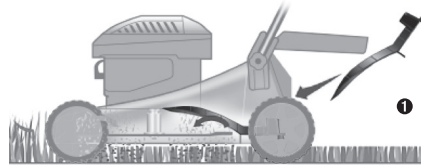

Standards of use

- 1) Always fit and dismantle the accessory with the engine off, after removing the ignition key (if supplied), or after disconnecting the cap from the engine spark plug.
- 2) Apply the "mulching" accessory and check that the fitted parts have been fastened correctly and securely.
- 3) You always need to work with the grass-catcher or stone-guard fitted properly even when using the "mulching" accessory.
- 4) Always avoid removing a large quantity of grass, to avoid blocking the cutting deck or overloading the engine and the cutting parts. Regulate the forward speed depending on the lawn conditions and the quantity of grass removed.

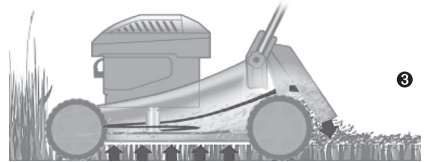
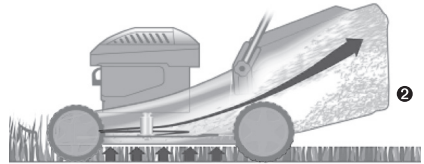

INSTRUCTIONS FOR ASSEMBLY AND DISMANTLING

Assembly

Lift the stone-guard and fit the deflector cap (1) in the outlet. Fasten it by fitting the two pins (2) into the holes provided until the fastener tooth clicks into place (3).

Dismantling

Lift the stone-guard and press down on the centre until the tooth (3) is released and remove the deflector cap (1).

STARTING YOUR MOWER

Read and understand the Safety Precautions before using your mower.

- Put Mountfield 4-stroke, or an SAE 10W-30 oil, in the oil filler (Figure 3). Do not overfill. The oil level should not be above the MAX mark on the dipstick. The oil tank capacity is 0,55 litre or 20 fluid oz of Mountfield oil, part number MX855, is available from any Mountfield stockist.
- Fill the fuel tank with UNLEADED petrol. Use only clean, fresh petrol - stale fuel may contain deposits that will clog the carburettor. Unleaded fuel can start to go stale after just 28 days. Do not overfill, the petrol level should be below the bottom of the fuel tank neck. Do not over tighten the fuel cap. The fuel cap breathes through the threads of the cap and over tightening can cause the engine to cut out.
- Ensure that the spark plug lead is securely connected to the spark plug.

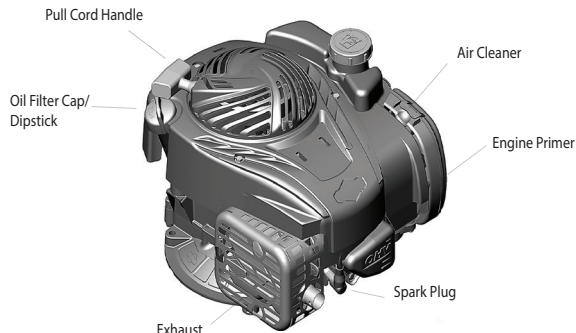

- When starting a new engine for the first time, firmly push the red primer 5 times. Then for all future starts, push the primer 3 times.

NOTE: If the engine runs out of fuel or has been stored for an extended period of time, it may be necessary to prime 5 times.

- 8 *NOTE: Priming is usually unnecessary when restarting a warm engine.*

NOTE: If you push the primer too many times, excessive fuel will flood the engine and it will be difficult to start.

- Pull and hold the Operator Presence Control (OPC) lever against the handle to disengage the engine brake.
THE ENGINE WILL NOT START, OR CONTINUE TO RUN, UNLESS THE OPC LEVER IS HELD AGAINST THE HANDLE
- Pull the starter cord with a strong smooth pull. Do not remove the pull cord from the guide.
- To engage the drive to the rear wheels on Self Propelled models, pull and hold the clutch lever against the handle.
- To stop the drive, release the clutch lever

NOTE: Using the primer is usually unnecessary when starting a warm engine. However, in cool weather it may be necessary to use the primer to start the engine.

STOPPING YOUR MOWER

- Release the Operator Presence Control (OPC) lever; this will engage the engine brake and operate the ignition safety cut out device.

ADJUSTING THE HEIGHT OF CUT

The height of cut adjustment not only determines the length of the cut grass, it also controls the airflow which carries clippings into the collector. If the discharge chute becomes blocked, increase the airflow by raising the height of cut. To prevent blockages when cutting long, thick grass, set the adjustment to the highest setting and cut the grass; then cut it again on a lower setting.

To adjust the height of cut:

- Stop the engine and disconnect the spark plug
- Put the mower on a level surface
- Adjust the cutting height lever by pulling outwards and moving into the required position (Figure 5)

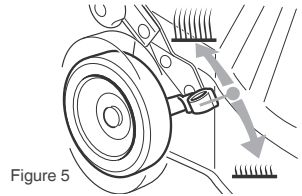
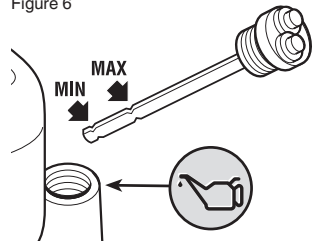

Figure 5

BEFORE EACH USE

- Always ensure that the mower is in a safe working condition. Inspect the cutter blade for damage; check safety devices and guards; check that all nuts, bolts and screws are secure.
- Check the oil level as follows:
 - a) Remove the oil filler cap and wipe the dipstick clean (Figure 6).
 - b) Refit the dipstick into the filler neck, do not screw it down. Remove the dipstick and check the oil level; oil should be at the MAX mark. The oil tank capacity is about 0,55 litre or 20 fluid oz.
 - c) If the oil level is low add Mountfield oil part number MX855 or a SAE 10W-30 oil, to the upper limit on the dipstick. Do not overfill; the oil level should not be above the MAX mark.
- Fill the fuel tank with unleaded petrol. Do not overfill, there is no need to fill tank to the top. The fuel tank need only contain enough fuel to complete the days mowing. If you run out of fuel, refilling must only be carried out once the engine has cooled. Fuel stored within the machine for 28 days or more can go stale and should be drained before further use.

Figure 6



MAINTENANCE



Stop the engine and disconnect the spark plug lead before working on the machine.

DO NOT TIP THE MOWER ONTO ITS SIDE AS THIS WILL FLOOD THE AIR FILTER WITH OIL.

To access the underside of the machine, lift the front wheels by lowering the handle until it rests on the ground.

CUTTER BLADE

Examine the cutter blade regularly for wear or damage.

- A slightly worn blade can be re-sharpened by your local dealer
- If the blade is damaged it should be replaced. Replacement blade kits are available from your Mountfield stockist. The part number for the blade kit is MS1196. If in doubt refer to your dealer, or telephone 0800 121 6585.

Blade must always be marked with part number ▲ 81004365/3

CLUTCH CABLE ADJUSTMENT (Self Propelled model only)

- Make sure that the clutch lever is fully released.
- Slacken the bottom nut and then tighten the top nut on the adjuster to take up any excess slack in the cable. The cable should have about 12mm of play on it (Figure 7).
- Engage the clutch lever and check that the rear wheels lock when the mower is pulled backwards.
- Start the mower and ensure it does not drive when the lever is disengaged.

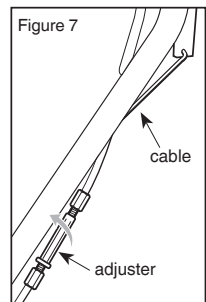

Figure 7

ENGINE

An engine Manufacturer's Owner's Manual is supplied with your mower.

Please read this, it provides detailed information on engine operation, maintenance and battery care. Repair work other than routine maintenance, should be carried out by an authorised dealer.

STORAGE

A little time spent on your mower after use will ensure many years of reliable mowing.

To access the underside of the cutter deck, ensure that the spark plug lead is disconnected. Then lift the front wheels by lowering the handle until it rests on the ground. Do not tip the mower onto its side, as this will flood the air filter with oil. Failure to maintain and care for your engine may invalidate the machine guarantee. Please see the guarantee statement for full terms and conditions.

AFTER EACH USE

- Remove any grass pulp from the underside of the cutter deck using a non-metallic instrument such as a piece of wood. Take care not to damage the paintwork.
- Examine the cutter blade for any damage. A damaged blade may upset the balance of your mower and cause excessive vibration. If in doubt refer to your dealer.
- Inspect the grass collector and clean it if necessary. If the mesh becomes clogged airflow will be reduced and impair grass collection.
- The handle can be folded down to reduce the amount of storage space required. Take care not to trap any of the operating cables when folding or unfolding the handle.
- Store the mower in a clean, dry area well away from any naked flames, sparks or heat source

LONG TERM - (if you are not using your mower for more than 28 days)

- Give the machine a thorough clean, paying particular attention to the underside
- Lubricate all moving parts
- At the end of the season, empty the fuel tank either by running the mower out of fuel or tip the machine backwards and onto the back right wheel to drain the fuel into a suitable container.

FAULT FINDING

PROBLEM	SOLUTION
Engine will not start	Check there is ample clean, fresh fuel in the tank. Any stale fuel needs to be drained from the machine.
	Check the cutter blade is not fouling the ground preventing free rotation.
	Check the petrol filler cap isn't on too tightly - it should only be finger tight.
Engine will not stop	Check the Operator Presence Control (OPC) lever is fully released.
	Remove spark plug lead to stop the engine using insulated gloves and refer to dealer.
Engine smokes	Engine may be overfilled with oil or may have been tipped.
Engine running unevenly	Check the petrol filler cap isn't too tight - it should only be finger tight. If fuel is over 28 days old it has gone stale and will need replacing.
Failure to cut grass properly	Stop the engine and disconnect the spark plug lead using heat resistant gloves.
	Check blade attachment bolt is tight.
	Check condition of blade. If seriously worn or damaged replace with a new one.
Failure to collect grass properly	Stop the engine and disconnect the spark plug lead using heat resistant gloves
	Check and make sure there is no build up of grass inside the casing.
	Check grass collector is allowing air to flow through the fabric. If it is clogged it should be washed carefully.
	If the grass collector is not clogged raise the height of cut to increase airflow.
	Check to ensure the engine is running at the correct speed (approximately 3,000rpm)
If conditions are too severe to use the grass collector, remove it and work with the deflector in position	
Machine vibrates excessively	This will certainly indicate that the blade has become badly damaged. Stop the engine, disconnect the spark plug lead and examine the blade assembly. Refer to your local dealer.

Guarantee

Congratulations on the purchase of your Mountfield lawnmower. This product has been manufactured to the highest quality standards and is guaranteed for domestic use against faulty parts or manufacture for a period of 2 years from the date of purchase. Please note that if the machine is used commercially the guarantee period is 90 days from the date of purchase. If you experience any problem with your Mountfield lawnmower please call our technical helpline on 0800 121 6585 and our operators will endeavour to solve your problem. In the event your problem cannot be resolved over the phone the operator will refer you to one of our local authorised service centres.

This guarantee is subject to the following terms:





- This guarantee is not transferable. An original proof of purchase will be required in the event of a claim.
- The product must be serviced at the recommended intervals by an authorised service centre. A service schedule should be kept including invoicing and receipts. Please phone 0800 121 6585 to locate your nearest Mountfield service centre or visit www.servicelink.org.uk. Service procedures (for example carb cleaning, draining engine oil, blade sharpening, belt and cable adjustment) and consumable parts that require periodic replacement (for example the spark plug, air filter and oil) are not covered under this guarantee. This also applies to parts subject to fair wear and tear (for example wheels, bearings, starter cord, cables, belts and blade).
- Delivery and collection of the machine is your responsibility and not covered under this guarantee.
- The guarantee does not cover any breakages or damage that are a result of the following; misuse, alteration, improper assembly or adjustment, neglect or accident.
- Expenses and costs incurred from loss of utility will not be compensated.
- The guarantee does not cover machines that are transported outside of the UK & Eire.
- Where a mower is fitted with an engine not manufactured by Mountfield, the engine manufacturer guarantees the engine.

This guarantee is in addition to and does not detract from your contractual rights under statute or common law.

On delivery of your new Mountfield mower, we suggest that you complete the box to the right.

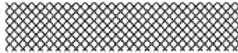
The information for your machine is on the serial number label, which is fixed on the cutter deck at the base of the handles. You will be asked for these details if you have any problems or require spare parts.

Please keep your receipt, proof of purchase will be required in the event of a claim.

	
Model:	
Type:	dB
(Year) S/N°	

Service Record	
<u>1st Service</u>	<u>2nd Service</u>
Date of service	Date of service
Next service due	Next service due
Dealer's Signature	Dealer's Signature
Dealer's Stamp:	Dealer's Stamp:

GGP UK LIMITED
Unit 8, Bluewater Estate, Bell Close, Plympton, Plymouth, Devon, PL7 4JH, England.

manufactured by GGP ITALY SpA Via del Lavoro, 6 I-31033 Castelfranco Veneto (TV) Italy