

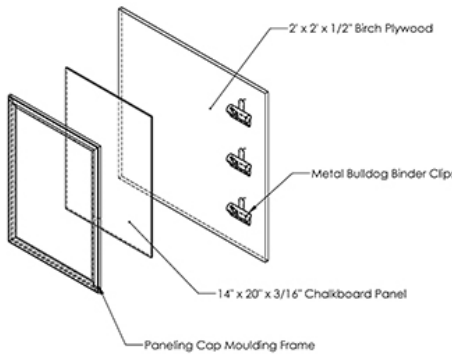

DIMENSIONS™



DIY PROJECT PLANS

YOU WILL NEED

- 1 - 2' x 2' x 1/2" birch project panel
- 1 - 2' x 4' x 3/16" chalkboard panel
- 1 - 1-1/8" x 3/8" x 8' panel cap moulding
- 3 - Metal bulldog binder clips
- 3 - #8 x 1/2" Truss-head screws/lath screws

Wood glue

Wood filler (optional)

Picture-hanging hardware or damage-free picture-hanging strips

Paint or stain and brushes
FINISHING IS OPTIONAL

TOOLS NEEDED

- Tape measure or long ruler
- Phillips-head screwdriver
- Mitre saw and mitre box or power miter saw

PROJECT COST

About \$35

ESTIMATED TIME

1 hour



Reminders, Recipes, Menus, Memories: So-Many-Uses Chalkboard with Clips

Let's get started!

STEP 1

Using a tape measure or a long ruler, measure, mark and cut your chalkboard to create a 14" x 20" panel. TIP: If the store where you buy your panel offers complimentary cutting, ask them to cut it for you.

STEP 2

Determine which side of your project panel will be the front, then measure and mark the location of your chalkboard's four corners. These should be 2" inside the top and bottom left corners (as shown below), and two more 14" to the right.

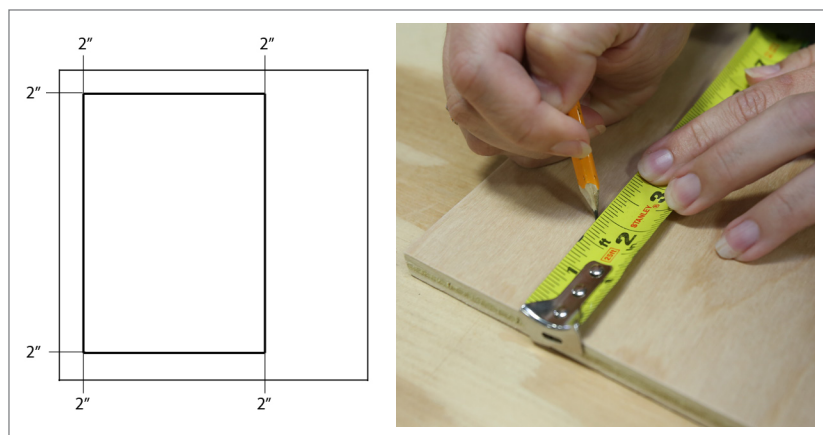

NOTE: If you choose to paint or stain your project panel, do so before making your marks. Just make sure you let each finishing step dry thoroughly before moving to the next.

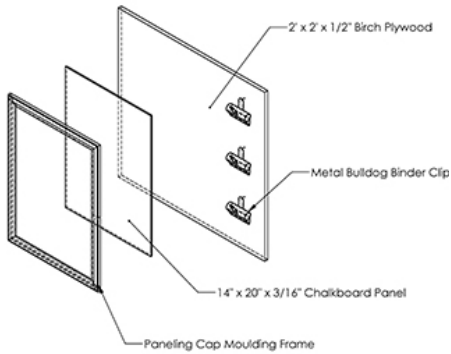

STEP 3

Apply wood glue to the back of the chalkboard panel. Carefully align the chalkboard to the corner marks on your project panel and press firmly into place.

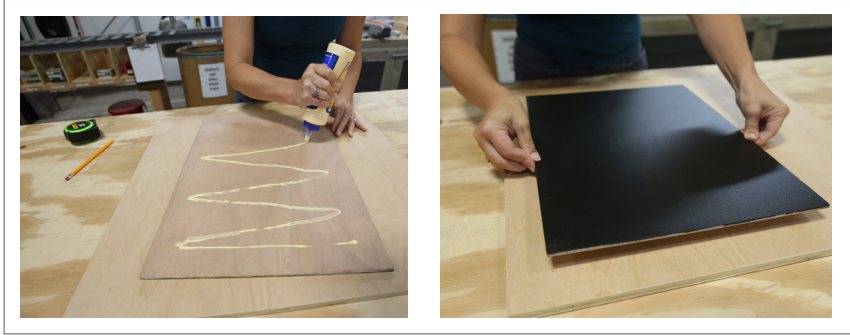

STEP 4

Use your mitre saw and box to cut two 20-3/4" cap moulding pieces and two 14-3/4" pieces. Next, with the moulding facing right-side-up, cut a 45-degree angle inward on each end.

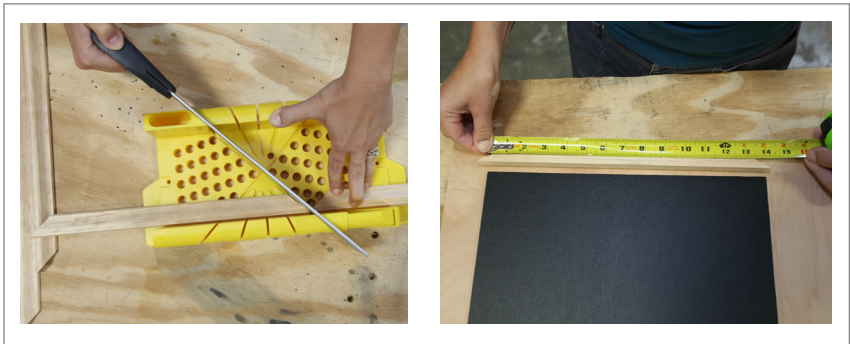

OPTIONAL

If you'd like to add a few small finishing nails to secure the moulding, use wood filler to hide the holes.

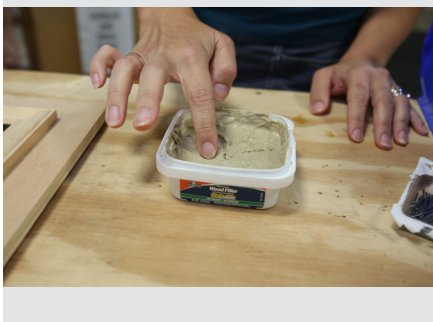
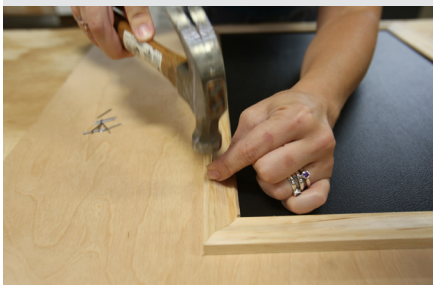

STEP 5

Run a bead of wood glue along the inside angle of each piece of cap moulding and press firmly against the four sides of the chalkboard.

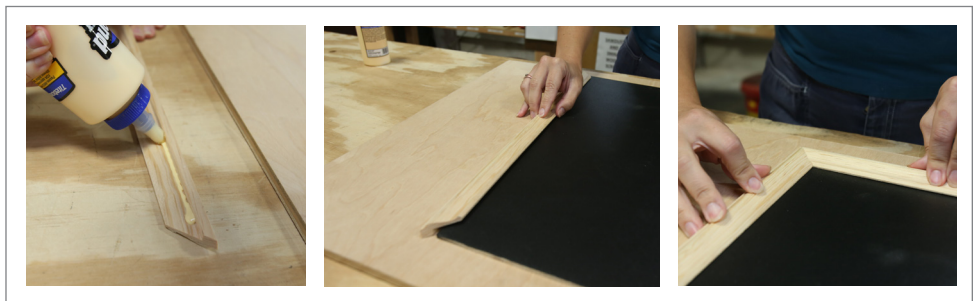



DIMENSIONS™

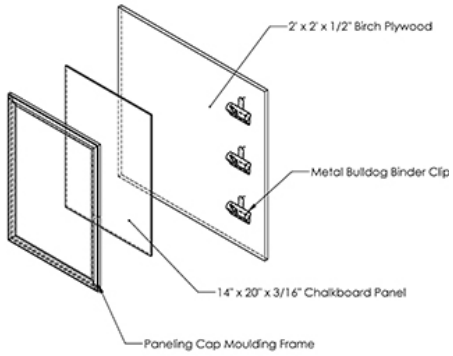

OPTIONAL

In place of binder clips, use hooks — or a combination of both!



STEP 6

Make a plan for where you'd like to attach your binder clips, then measure and mark them on your project panel. Secure the binder clips with the screws recommended in the You Will Need list on pg. 1.



YOU DID IT!

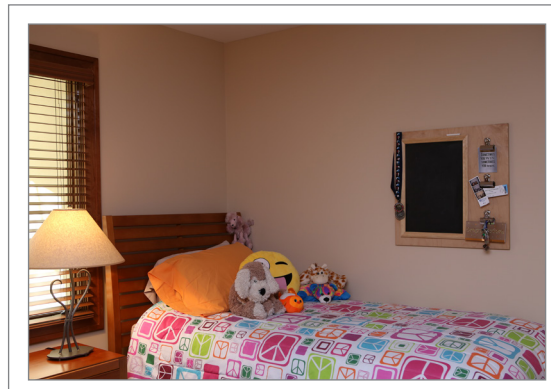



DIMENSIONS™

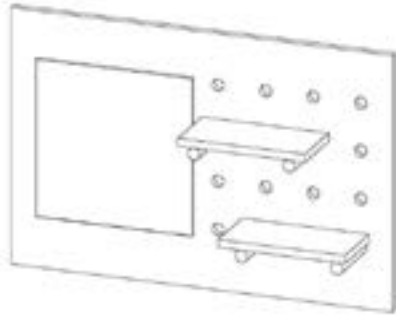

DIY PROJECT PLANS

YOU WILL NEED

1 - 3/4" birch plywood

2' x 2' project panel

1 - 3/4" x 48" dowel rod

1 - 12" x 12" mirror

Mirror adhesive and caulk gun

Medium-grit sandpaper

Wood glue

Picture-hanging hardware
or damage-free picture
hanging strips

Paint or stain and brushes
(Finishing your pegboard is optional;
we left ours unfinished for an ultra-
Scandinavian look.)

TOOLS NEEDED

Tape measure or long ruler

Pencil

Skill saw or table saw

Power drill with 3/4" router bit

PROJECT COST

About \$30

ESTIMATED TIME

1-2 hours



Entryway Pegboard with Mirror, Adjustable Shelves and Dowel Hooks

Let's get started!

STEP 1

Using a tape measure or a long ruler, measure and mark the following cuts on your project panel and dowel. Or...

TIP! If the store where you buy your project panel and dowel offers complimentary cutting, bring this with you and ask them to cut your panel as shown below. Then skip right to Step 3.

STEP 2

Use a skill saw or a table saw to cut your project panel into five pieces and the dowel into ten 4.5" lengths.

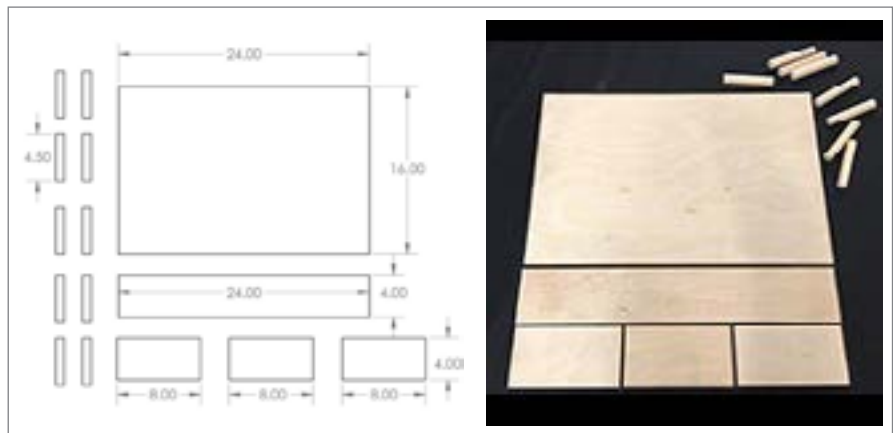

COMPANION PROJECT IDEA! Set aside the extra, unneeded 4" x 24" piece of panel and 3 or 4 lengths of dowel. After this project, use the same methods described here to make an additional 3- or 4-hook companion piece for more hanging space without needing to buy any additional materials or supplies.

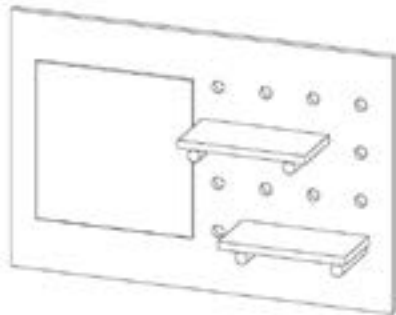

STEP 3

Use your measuring tape to mark the center of the dowel holes as shown below. Pay special attention to accuracy so they end up as evenly spaced as possible.

Center your mirror in the empty area to the left, about 1" from the left edge and 2" from the bottom. Mark its four corners with a pencil.

STEP 4

Use your power drill with a 3/4" router bit to drill through the center of your 16 dowel holes.

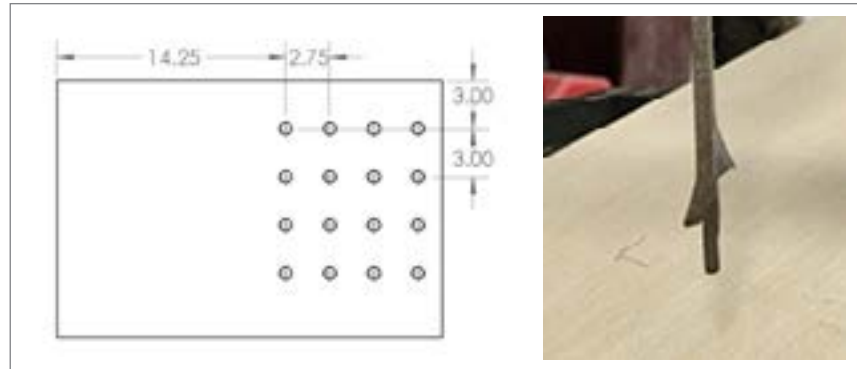

STEP 5

Sand the edges of the project panel and the inside of each dowel hole until smooth.



Note: This is the best time to paint or stain your project if desired. Just make sure you let each step dry thoroughly before moving on to the next.

OPTIONAL

If you'd like your pegboard to stand out 3/4" from the wall, use your skill saw to cut your extra 4" x 8" piece of panel widthwise into four small blocks of equal size (2" x 4" each). Turn your pegboard facedown and use your wood glue to secure a block in each corner.



STEP 6

Apply the mirror adhesive to the back of the mirror and press onto the pegboard at your corner marks.



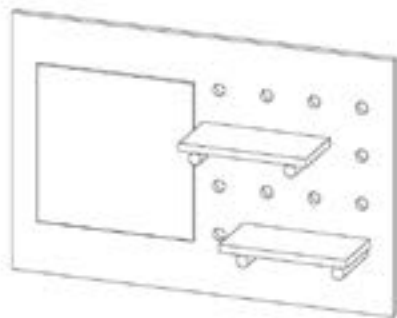

OPTIONAL

If you'd like to permanently secure the shelves in place, use a small paint brush to coat the inside of each hole, the inserted portion of each dowel, and the back of each shelf with wood glue. Set the shelves in place and allow glue to dry.

Note: This is why it's important to determine how you want to hang your pegboard and install that system in Step 7—because if you'd like to glue your shelves in place, it will be difficult to place your pegboard facedown to apply mounting strips or hanging hardware in Step 8.



STEP 7

Plan your wall mounting method. We used damage-free picture hanging strips, but if you'd prefer to use traditional picture-hanging hardware, you'll find a variety of options at your local hardware store. Be sure to follow the hardware manufacturer's installation instructions carefully, including the installation of any necessary wall anchors.

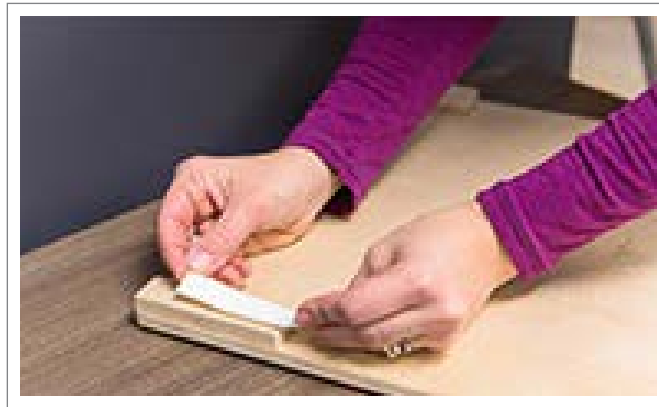

STEP 8

Decide where you'd like your shelves positioned by inserting four dowels — two per row of your choice with an open hole in between. Place your two remaining 4" x 8" pieces of project panel across them, creating shelves.

Next, hold one of your shelves firmly against the dowels and try moving it to a different position on your board. This is your moment of truth! How well did you evenly space your holes? If your dowel shelves can be moved to any other position on the pegboard, YOU DID IT! A+!

Once you've determined your shelf placements, carefully mark the position of each dowel on the underside of each shelf and use your wood glue to adhere them.

Hang your masterpiece, add your shelves and use your extra dowels to dress it up any way you'd like. Enjoy!

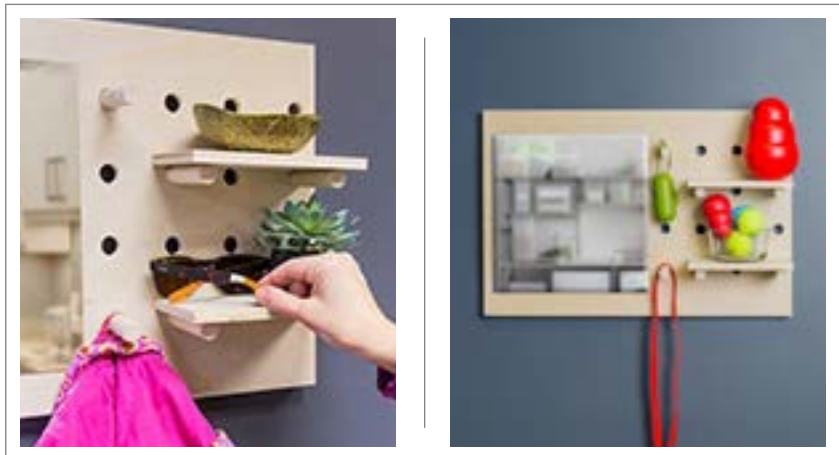



DIMENSIONS™



DIY PROJECT PLANS

YOU WILL NEED

1 - Dimensions™ 3/4" x 2' x 4' birch plywood project panel cut into three 24" x 16" sections

4 - 3/8" x 24" threaded rods

16 - 3/8" nuts

7' of 3/4" black steel pipe (or furniture-grade PVC) cut to four 14" lengths and four 7" lengths

1 - 3/4" x 15.5" black steel pipe nipples

2 - 3/4" x 10" black steel pipe nipples

4 - 3/4" x 2" black steel pipe nipples

2 - 3/4" black iron 90° FPT x FPT elbows

2 - 3/4" black iron threaded tees

4 - 3/4 in. black iron 90° FPT x MPT street elbows

4 - 3/4" black iron FPT floor flanges

16 - 3/4" black screws

4 - 4" general-duty rubber swivel caster wheels with brakes

16 - 3/4" slotted hex washer head sheet metal screws

Denatured alcohol and a soft rag for cleaning pipes and fittings

Optional: Clear polyurethane, paint or stain of your choice

(Project Plans cont. on pg. 2)



Pipes-and-Fittings DIY Bar Cart

Let's get started!

STEP 1

Using a tape measure, mark the cuts needed to your 2' x 4' project panel as indicated in the gray box to the left. Make your cuts using a table saw or follow the tip below. Then use the rest of the list on the left to gather all remaining items needed to complete your project.

TIP: If the store where you buy your panels offers complimentary cutting, bring this plan with you and ask them to make your cuts.

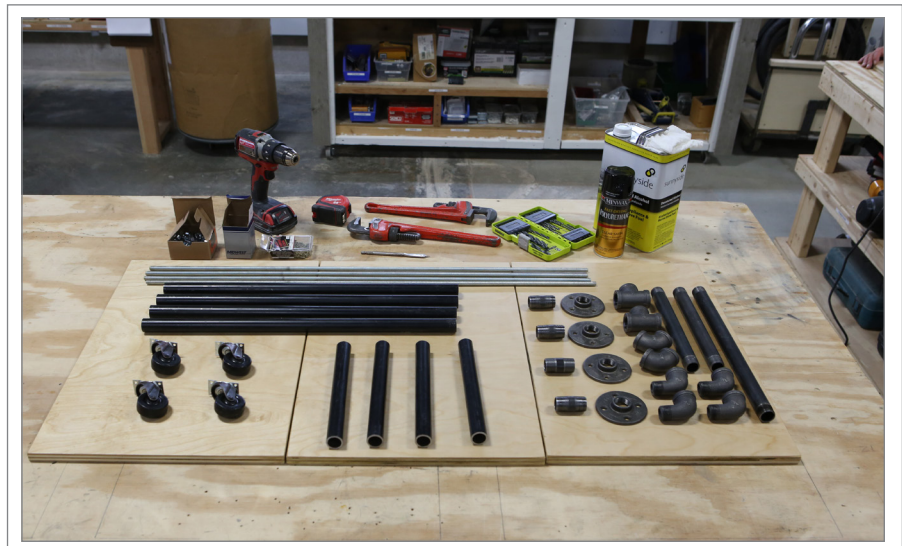



DIMENSIONS™



DIY PROJECT PLANS CONT.

TOOLS NEEDED

Tape measure
Pencil
Table saw if making your own cuts
Power drill and bit set
7/16" spade bit
Sand paper or power sander
Standard adjustable wrench set
Level
2 - 12" pipe wrenches

PROJECT COST

About \$170

ESTIMATED TIME

2 hours

STEP 2

From the short ends of each panel, measure and mark 3-3/8" in and 2-1/8" down (top-row photos).

Using a 7/16" spade bit, center carefully and drill through-holes at each of your 12 marks (bottom-row photos).

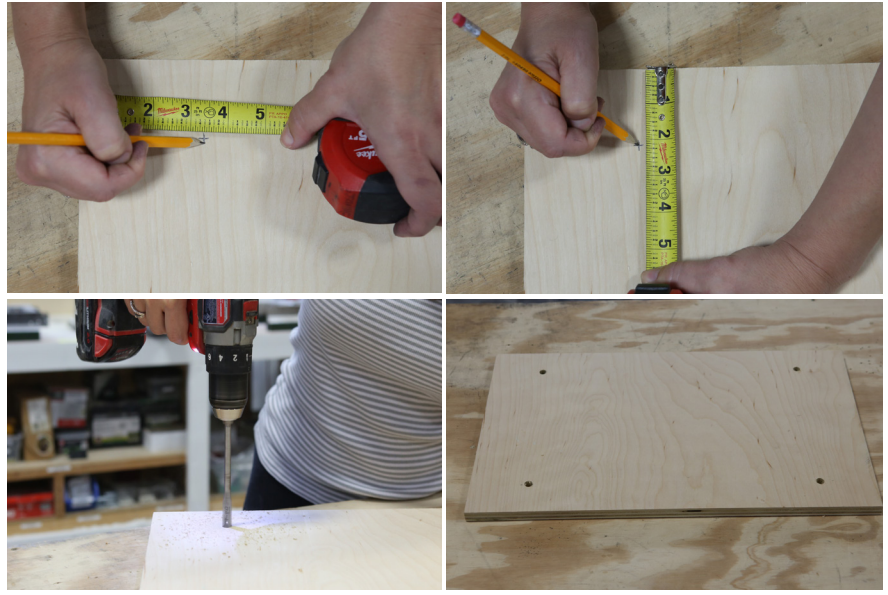

STEP 3

Sand your panels with either sand paper or a power sander and wipe clean (top left photo below).

If you wish, spray one or two coats of clear polyurethane, stain or paint your panels following the manufacturer's instructions (top right photo).

Use denatured alcohol to clean all pipes and fittings with a clean rag (bottom photo).





DIMENSIONS™



STEP 4

Thread one nut about 1-1/2" up each threaded rod and follow with a washer (top left photo).

Insert the short end of the rod through each of your bored holes (top right photo).

Add a washer and thread a nut flush to the end of each rod (middle photo).

Stand your project upright on a flat surface and tighten the four top nuts using a pair of standard adjustable wrenches – one to hold the bottom nut in place and one to tighten the top nut. Check for level and adjust nut heights if necessary (bottom photos).

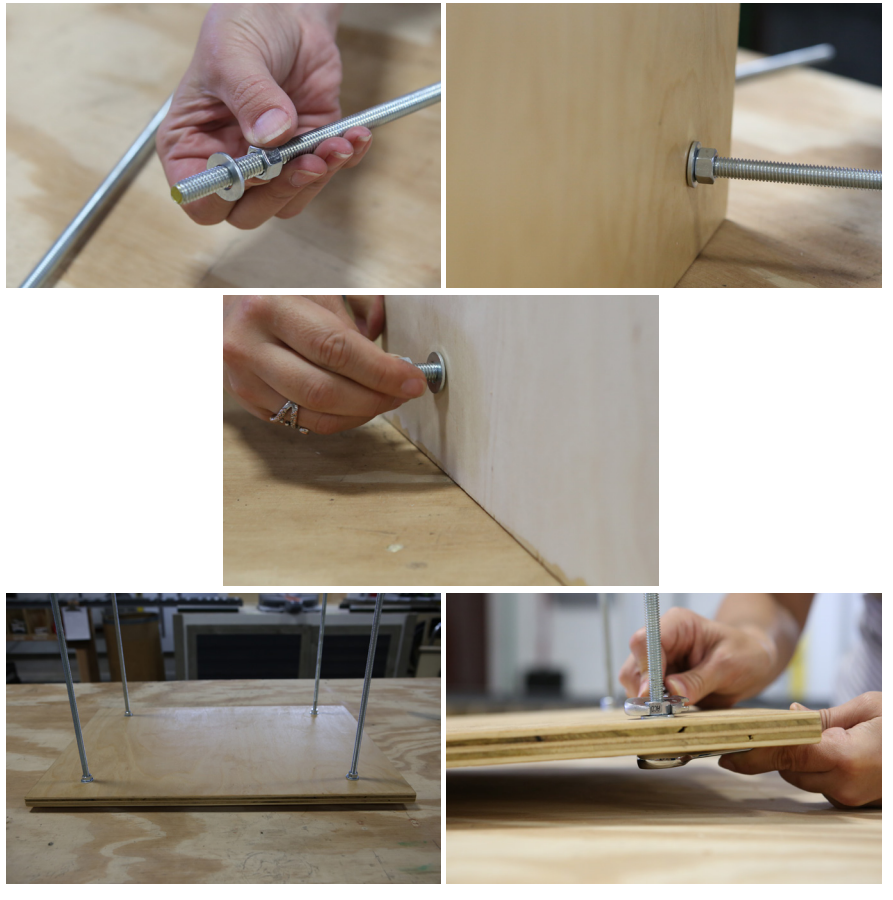



DIMENSIONS™



STEP 5

Place a 14" section of black pipe over each rod. Then, using the holes in a second panel, place the panel down over the rods (top photos). Drop a washer over each and thread a nut all the way down (middle photos). Tighten lightly with a wrench. **NOTE:** Before tightening, use a level to ensure each pipe is vertically straight and hold in place (bottom photo).

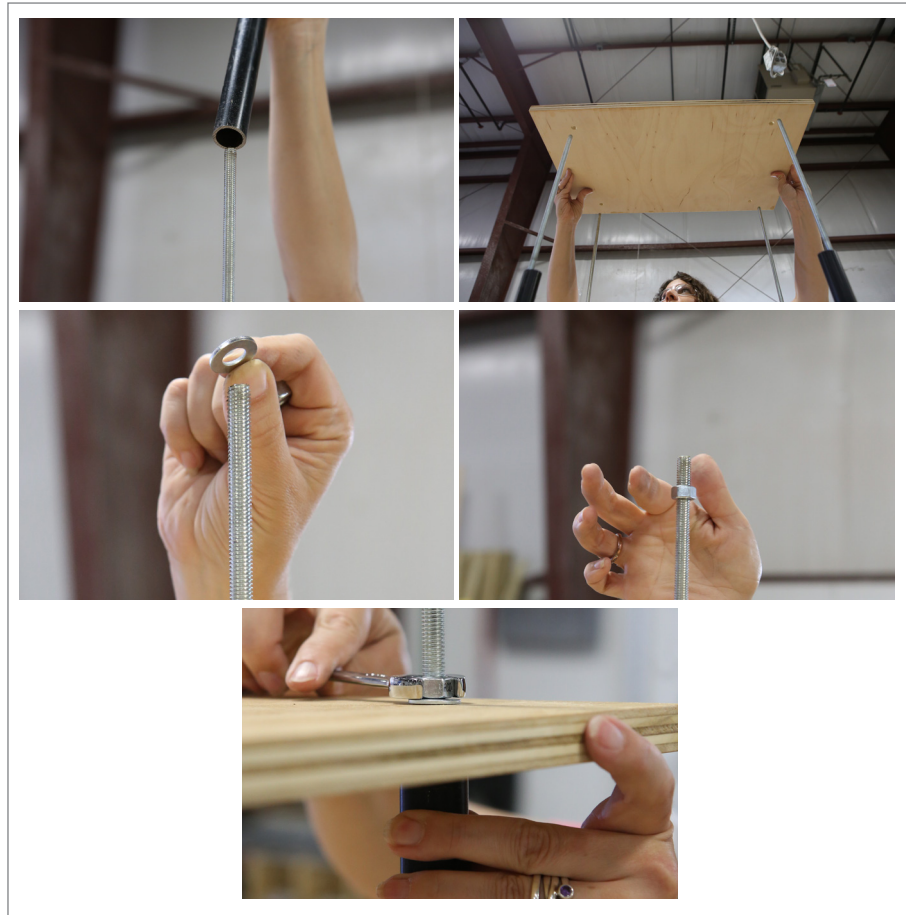

STEP 6

Place each 7" piece of black pipe over each rod, then place the last panel down over the rods (top photos below). Drop a washer over each rod and tighten a nut to each (bottom photos). **NOTE:** Before tightening completely, use a level to ensure each pipe is vertically straight.

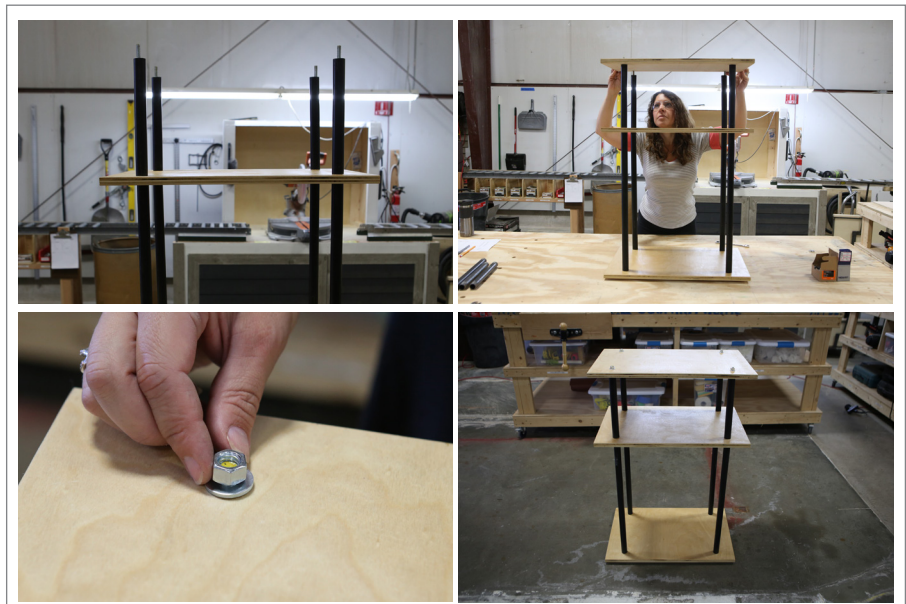



DIMENSIONS™



Below, top: Completed assembly
Bottom: Place the whole assembly over the nuts on the top shelf of your bar cart.

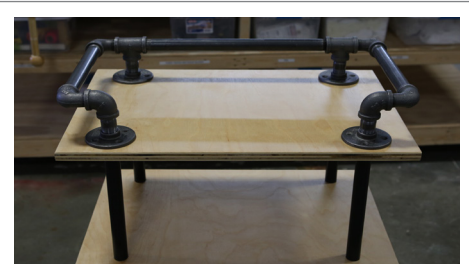

STEP 7

Lay out your black steel threaded pipe nipples and fittings as shown in the photo to the left. Assemble as follows using pipe wrenches to adjust each pipe nipple and fitting into position as you go:

1. At each end of the 15.5" pipe nipple, attach a tee followed by a street elbow (first-row photos)
2. Attach a 10" pipe nipple to each street elbow (second-row photos)
3. Attach a 90° elbow to each 10" pipe nipple (third-row photos)
4. Attach a street elbow to each 90° elbow (fourth-row photos)
5. Attach a 2" pipe nipple to each street elbow **and** to each of the two tees. Set assembly on a flat surface and adjust 2" nipple heights until level. Attach the four flange feet and adjust to level (fifth-row photos).





DIMENSIONS™



STEP 8

Mark and predrill 16 **pilot holes** for the 3/4" black screws (top-row photos below). Use a drill extender to attach the flange feet to the top shelf of the bar cart using a Phillips head driver bit (bottom-row photos).



STEP 9

Lay the bar cart on its side. On the underside of the bottom shelf, place a caster wheel at each corner and mark for predrilling (top left photo below).

Measure and mark your drill bit with a piece of tape to avoid drilling all the way through the bottom shelf (top right photo).

Predrill 16 pilot holes for the 3/4" slotted hex washer head screws (bottom left photo).

Attach the caster wheels to the bottom of the bar cart using a hex head driver bit (bottom right photo).





DIMENSIONS™

YOU DID IT!

Enjoy your bar cart in your home, on your deck, in your office or give it as a gift. No matter how or where you use it – for drinks and fun with friends and family, as a coffee station or as a great-looking storage and organizational piece – everyone will love its personality and style.

