

# Agilent GC Injector 80



## User Manual

# Notices

© Agilent Technologies, Inc. 2010

No part of this manual may be reproduced in any form or by any means (including electronic storage and retrieval or translation into a foreign language) without prior agreement and written consent from Agilent Technologies, Inc. as governed by United States and international copyright laws.

## Manual Part Number

G6502-90000

## Edition

08/2010

Printed in Germany

Agilent Technologies  
Hewlett-Packard-Strasse 8  
76337 Waldbronn

**This product may be used as a component of an in vitro diagnostic system if the system is registered with the appropriate authorities and complies with the relevant regulations. Otherwise, it is intended only for general laboratory use.**

## Warranty

**The material contained in this document is provided “as is,” and is subject to being changed, without notice, in future editions. Further, to the maximum extent permitted by applicable law, Agilent disclaims all warranties, either express or implied, with regard to this manual and any information contained herein, including but not limited to the implied warranties of merchantability and fitness for a particular purpose. Agilent shall not be liable for errors or for incidental or consequential damages in connection with the furnishing, use, or performance of this document or of any information contained herein. Should Agilent and the user have a separate written agreement with warranty terms covering the material in this document that conflict with these terms, the warranty terms in the separate agreement shall control.**

## Technology Licenses

The hardware and/or software described in this document are furnished under a license and may be used or copied only in accordance with the terms of such license.

## Restricted Rights Legend

If software is for use in the performance of a U.S. Government prime contract or subcontract, Software is delivered and licensed as “Commercial computer software” as defined in DFAR 252.227-7014 (June 1995), or as a “commercial item” as defined in FAR 2.101(a) or as “Restricted computer software” as defined in FAR 52.227-19 (June 1987) or any equivalent agency regulation or contract clause. Use, duplication or disclosure of Software is subject to Agilent Technologies’ standard commercial license terms, and non-DOD Departments and Agencies of the U.S. Government will

receive no greater than Restricted Rights as defined in FAR 52.227-19(c)(1-2) (June 1987). U.S. Government users will receive no greater than Limited Rights as defined in FAR 52.227-14 (June 1987) or DFAR 252.227-7015 (b)(2) (November 1995), as applicable in any technical data.

## Safety Notices

### CAUTION

A **CAUTION** notice denotes a hazard. It calls attention to an operating procedure, practice, or the like that, if not correctly performed or adhered to, could result in damage to the product or loss of important data. Do not proceed beyond a **CAUTION** notice until the indicated conditions are fully understood and met.

### WARNING

A **WARNING** notice denotes a hazard. It calls attention to an operating procedure, practice, or the like that, if not correctly performed or adhered to, could result in personal injury or death. Do not proceed beyond a **WARNING** notice until the indicated conditions are fully understood and met.

# In This Book

This book describes the Agilent GC Injector 80 (G6502B).

## **1 General Information**

This chapter provides safety information and gives an introduction on how to use this manual.

## **2 Operating Instructions**

This chapter explains the operational parameters of the System

## **3 Agilent GC Injector 80 Description and Installation**

This chapter gives an overview and information about the installation of your Agilent GC Injector 80 System.

## **4 Appendices**

This chapter provides addition information on definition of terms, naming convention, injection cycle, firmware, external connectors and accessories.

# Contents

<b>1</b>	<b>General Information</b>	<b>5</b>
	Safety Information	6
	How to Use this Manual	12
<b>2</b>	<b>Operating Instructions</b>	<b>13</b>
	Using the Control Terminal	15
	Methods	18
	Job and Job Queue	21
	Utility Functions	24
	Logfile	33
	Info Functions	34
	Setup Functions	38
<b>3</b>	<b>Agilent GC Injector 80 Description and Installation</b>	<b>41</b>
	General System Overview	43
	Installation	49
	Object Positions	59
	Syringes	71
	Interfacing the GC PAL to other Devices	75
	Loader Program	78
	Special Functions	79
	Troubleshooting	99
	Replacing Parts	103
	Maintaining the Autosampler System	107
<b>4</b>	<b>Appendices</b>	<b>109</b>
	Definition of Terms	110
	Conventions of Naming	113
	Injection Cycles	114
	Software Flow Chart	128
	External Connectors	132
	Accessories	137



# 1 General Information

Safety Information 6

How to Use this Manual 12

This chapter provides safety information and gives an introduction on how to use this manual.



## Safety Information



### **General Considerations**

The GC Injector 80 System User Manual and the corresponding “Addendum” for a specific module must be consulted by the user under all circumstances before a unit is put in use.

Changes or modifications to this unit not expressly approved by the party responsible for compliance could void the user’s authority to operate the equipment.

The user shall be made aware that if the equipment is used in a manner not specified by the manufacturer, the protection provided by the equipment may be impaired.

When using the GC Injector 80 System, follow the generally accepted procedures for quality control and methods development.

When you use the GC Injector 80 System in the field of chromatographic analysis and you observe a change in the retention of a particular compound, in the resolution between two compounds, or in peak shape, immediately determine the reason for the changes. Until you determine the cause of a change, do not rely on the separation results.

### **Electrical Hazards**

Every analytical instrument has specific hazards, so be sure to read and comply with the following precautions. They will help ensure the safe, long-term use of your GC Injector 80 System.

The Installation Category (Over voltage Category) for this instrument is Level II. The Level II Category pertains to equipment that receives its electrical power from the local level, such as an electrical wall outlet.

Only use fuses of the type and current rating specified. Do not use repaired fuses and do not short-circuit the fuse holder.



The supplied power cord must be inserted into a power outlet with a protective earth contact (ground). When using an extension cord, make sure that the cord also has an earth contact.



Do not change the external or internal grounding connections. Tampering with or disconnecting these connections could endanger you and/or damage the GC Injector 80 System.

The instrument is properly grounded in accordance with these regulations when shipped. You do not need to make any changes to the electrical connections or the instrument's chassis to ensure safe operation.



The combination of a GC Injector 80 System with a LC/MS System does require the safety measure as described by the LC/MS System manufacturer. Detailed instructions for the safety grounding on the LC/MS system are outlined in the corresponding operating/installation manual.

Agilent Technologies recommends to use a grounding cable connected on one side at the Injection Valve, Loop or any other suitable direct metallic contact and the other side at an appropriate grounding point at the LC/MS System. This supplementary grounding measure will support the safety strategy of the LC/MS System manufacturer.



Do not turn the instrument on if you suspect that it has incurred any kind of electrical damage. Instead disconnect the power cord and contact a Agilent Technologies representative for a product evaluation. Do not attempt to use the instrument until it has been evaluated. Electrical damage may have occurred if the GC Injector 80 System shows visible signs of damage, exposure to any liquids or has been transported under severe stress.

Damage can also result if the instrument is stored for prolonged periods under unfavorable conditions (e.g. subjected to heat, water, etc.).

## 1 General Information

### Safety Information



In any case disconnect the power cord(s) from the power supply or from the different power supplies if optional devices are installed before attempting any type of maintenance.

Capacitors inside the instrument may still be charged even if the instrument is turned off.



To avoid damaging electrical parts, do not disconnect an electrical assembly while power is applied to the GC Injector 80 system. Once the power is turned off, wait approximately 30 seconds before you disconnect an assembly.

The instrument includes a number of integrated circuits. These circuits may be damaged if exposed to excessive line voltage fluctuations and/or power surges.



Never try to repair or replace any components of the instrument that is not described in this manual without the assistance of a Agilent Technologies representative.

There are no operator-serviceable or replaceable parts inside the power supply(ies) or in the GC Injector 80 System. If a power supply is not functioning, contact a Agilent Technologies representative.



The power supply for the GC Injector 80 Instrument has the symbols 1/0 on the label for the power switch to switch ON/OFF.

Any additional power supply for other devices like, Cooled Stack or a Valve Module shows the symbols as shown below on the label for the power switch:



The symbols shall warn the user that in a emergency case more than one power supply has to be turned OFF or more than one power cord has to be pulled from power supply or from the wall outlet to shut down the complete GC Injector 80 System.



If the basic GC Injector 80 System is installed, than a single power supply is installed only. Turning OFF the power supply or pulling this single power cord in an emergency case will stop the complete GC Injector 80 System.

It is important that the power supply (ies) are in a location where the power ON and OFF switch is accessible and easy to operate, and where it is possible to unplug the AC power cord from the power supply/wall outlet in case of emergency.

### Other Hazards



To avoid injury during GC Injector 80 System operation, keep your hands away from the syringe.



Do not operate the GC Injector 80 System without the safety shield. The safety shield must be installed for safe operation.



To avoid injury, observe safe laboratory practice when you handle solvents, change tubing, or operate the GC Injector 80 System. Know the physical and chemical properties of the solvents you use. See the Material Safety Sheets from the manufacturer for the solvents in use.



Use caution when working with any polymer tubing under pressure:

- Always wear eye protection when near pressurized polymer tubing.
- Do not use polymer tubing that has been severely stressed or kinked.
- Do not use polymer tubing, in particular not PEEK or Tefzel tubing, with Tetrahydrofuran (THF), Dimethylsulfoxid (DMSO), chlorinated organic solvents, concentrated mineral acids, such as Nitric, Phosphoric or Sulfuric acids, or any related compounds to above listings.



Do not use vials without a sealing cap, microtiter or deepwell plates without a plate seal. Vapor phase from organic solvents can be hazardous and flammable. Acidic vapor phase can cause corrosion to critical mechanical parts.

## 1 General Information

### Safety Information

#### Disposal



Do not dispose of this equipment or parts thereof unsorted in municipal waste. Follow local municipal waste ordinances for proper disposal provisions to reduce the environmental impact of waste electrical and electronic equipment (WEEE). European Union customers: Call your local customer service representative responsible for the PAL System for complimentary equipment pick-up and recycling.

#### Lithium battery














An onboard lithium battery buffers the electronic memories, when the instrument is turned off. Replace it only with the same or equivalent type recommended by the equipment manufacturer.

Battery: Panasonic VL 2330, soldered directly on the electronic board. Discharged lithium batteries shall be disposed off locally according to national waste disposal regulations for batteries.

There are no operator-serviceable parts on the electronic boards. If an electronic board fails, contact a Agilent Technologies representative.

**Table 1** Commonly Used Symbols

Symbol	Description
	Caution or refer to User Manual
	Caution, Risk of Needle-Stick Puncture
	Caution, Hot Surface or High Temperature
	Direct Current
	Alternating Current
	Protective Conductor Terminal, Ground
	Fuse
I	Electrical Power ON. Used with Main GC Injector 80 Power Supply.
0	Electrical Power OFF. Used with Main GC Injector 80 Power Supply.
	Electrical Power ON for Only Part of the System. Used with Optional Device(s)
	Electrical Power OFF for Only Part of the System. Used with Optional Device(s)
	Caution, Risk of Electrical shock (high voltage)
	Disposal, Do not dispose in municipal waste. Follow local waste regulations to reduce electrical and electronic waste (WEEE).

## How to Use this Manual

The manual is divided into following major sections:

- Safety Information
- Operating Instructions
- Specifications
- Product Warranty
- Description and Installation
- Troubleshooting
- Replacing Parts
- Maintaining PAL System
- Appendices

The “[Operating Instructions](#)” on page 13 are intended for infrequent users or new users who already have experience using automated systems to perform standard analytical methods.

### NOTE

The system must be installed and set up properly before the Operating Instructions can be used.

---

Users who are installing a system or accessories, or who need to adjust an installed system, should consult “[Agilent GC Injector 80 Description and Installation](#)” on page 41.

The Appendices provide useful information such as the Software Flow Chart, Definition of Terms, Injection Cycle parameter descriptions, or the accessories guide.



## 2 Operating Instructions

Using the Control Terminal	15
Menu Screens	16
Function Keys	17
ESCape and STOP Keys	17
Scroll Knob and ENTER Button	17
Methods	18
Creating Methods	18
Edit / View Methods	20
Delete Methods	20
Job and Job Queue	21
Building and Starting a Job Queue	22
Aborting a Job Queue	23
Restarting an Aborted Job Queue	23
Utility Functions	24
Syringe	25
Tray	27
Injector	28
Wash Station	29
Vial	30
Dilutors	31
Tools	32
Logfile	33
Info Functions	34
Hardware	35
Software	35
Maintenance	36
Free Objects / Free Items	37



## 2 **Operating Instructions**

How to Use this Manual

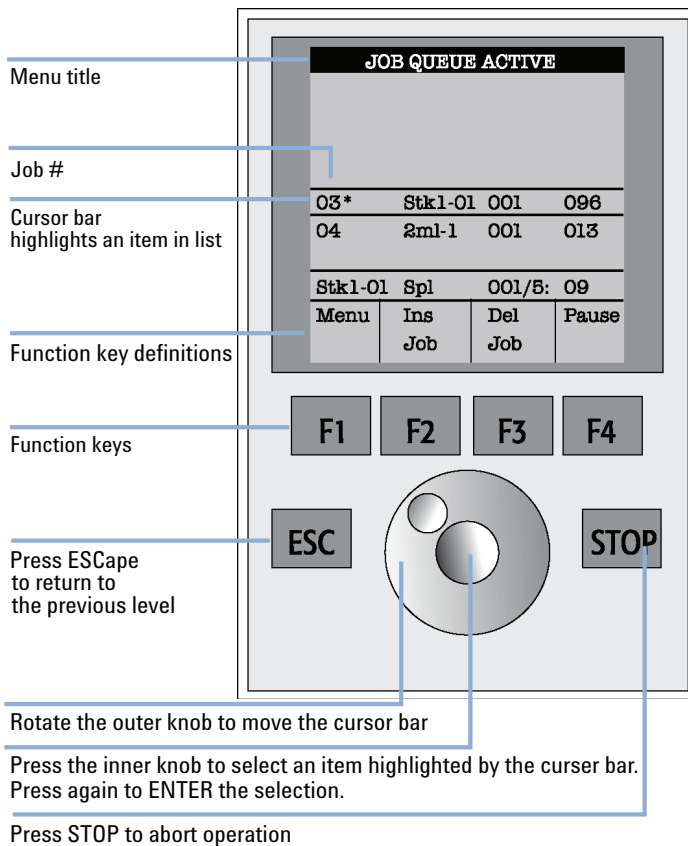
Setup Functions	38
Sounds	39
Time	39
Objects	40

This chapter explains the operational parameters of the System

## Using the Control Terminal

The following procedures present the key steps required to set up and process multiple groups of samples with the GC Injector 80. They are intended to provide an overview for new users and a reminder for infrequent users. The GC Injector 80 and all accessories should be installed with Objects defined correctly. A syringe of the specific type called for by a particular method should also be installed.

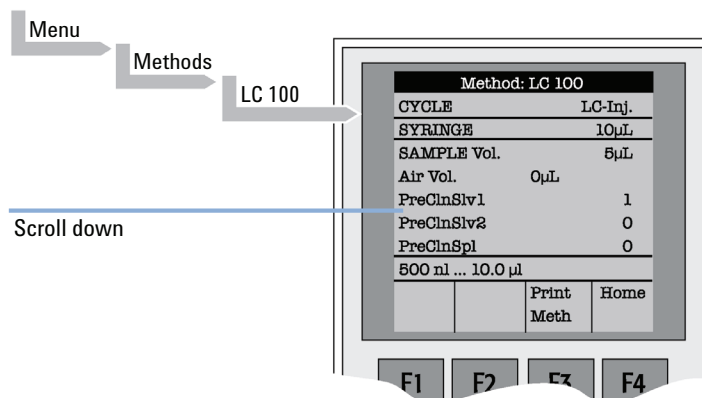
Figure 1 on page 15 illustrates the GC Injector 80 control terminal and the conventions used to enter, edit, and view information.



**Figure 1** GC Injector 80 Control Terminal and Conventions

## Menu Screens

Different menu screens are displayed, depending on the system operating status and the particular function being accessed by the operator. All menu screens have the same basic format. The menu title is displayed at the top of the screen. A list of items is displayed below the title. The date and time, or status, are shown in the highlighted area above the Function key labels on the bottom of the screen.



**Figure 2** Accessing a Method Screen



## Function Keys

Options for a particular menu are assigned to the corresponding function keys (**F1**, **F2**, **F3**, **F4**) directly below each function key label.

Pressing the function key labeled as **Home** will always return to the **Job Queue** menu.

## ESCAPE and STOP Keys

Press **ESCAPE** to return to the previous menu. Press **STOP** to abort the current **Cycle**, **Job**, or **Job Queue**.

## Scroll Knob and ENTER Button

Rotate the outer knob to scroll through items in a menu list. To select a highlighted item press the central knob (**ENTER**). Then use the outer knob to scroll through available options for that item or to change a numeric value. Then press the inner knob again to *ENTER* the displayed option. The inner knob is also used for other operations that require an *ENTER* operation to continue or complete an operation.

## Methods

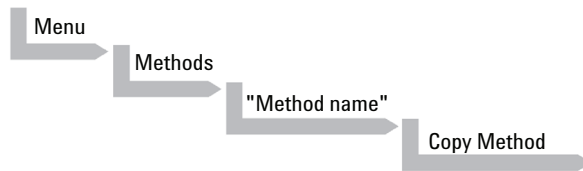
### Creating Methods

Methods can be defined by the user and assigned names up to eight characters in length. **Methods** can be created, copied, edited, and viewed from the Methods menu. Methods can be viewed (but not edited) from the Job Queue menus.

Methods are created by either copying an existing Method or creating a new Method.

**To copy a Method, complete the sequence as follows:**

1

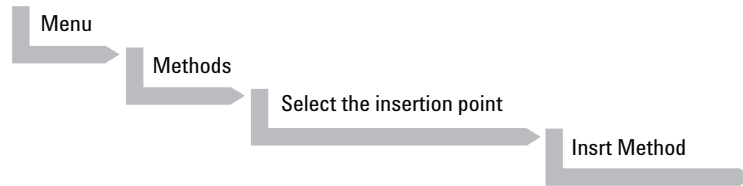


You will be prompted to enter a name for the new Method.

- 2 Use the scroll knob and the left-right arrow function keys (**F2** and **F3**) to select among alphanumeric characters and spaces. Press the **ENTER** function key (**F4**) to accept the name.

To create a new Method, complete the following steps:

**1**



**2** Assign and enter a new Method name as above.

After a copy of the Method has been created, the Method parameters will display and can be edited. The Cycle and Syringe entries cannot be changed.

**3** If the Method is new (i.e. added), select and enter a Cycle that is appropriate for the application.

**4** Select the specific Syringe to be used by the Method.

**NOTE**

Once a Method has been created and saved, the Cycle and Syringe cannot be changed. To use a different Cycle or Syringe, a new Method must be created.

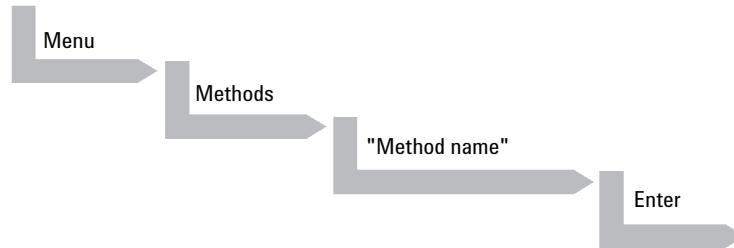
**5** Assign Parameter values according to the application requirements. Consult “[Injection Cycles](#)” on page 114 for details on specific items.

## Edit / View Methods

Method parameters (excluding Cycle and Syringe) can be viewed and changed from the Method menu as follows:

Complete the following menu selections:

1

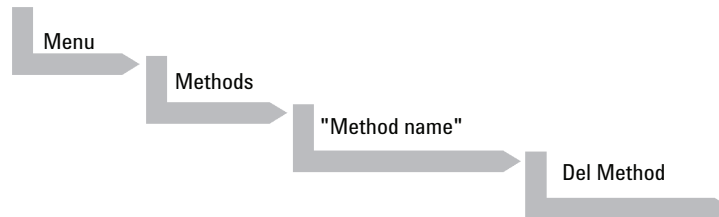


- 2 Scroll to and select the parameter to be changed. Assign the new value and press **ENTER**.
- 3 Exit from Parameter List by pressing either the **Home** function key (**F4**) to return to the top-level **Job Queue** menu or **ESC** to return to the previous menu.
- 4 Method contents may be viewed from the **Job Queue** displays by selecting the desired Job, pressing **ENTER**, followed by the **View Method** function key.

## Delete Methods

Methods can be deleted from the **Methods** menu. Methods in use by an active **Job** cannot be deleted.

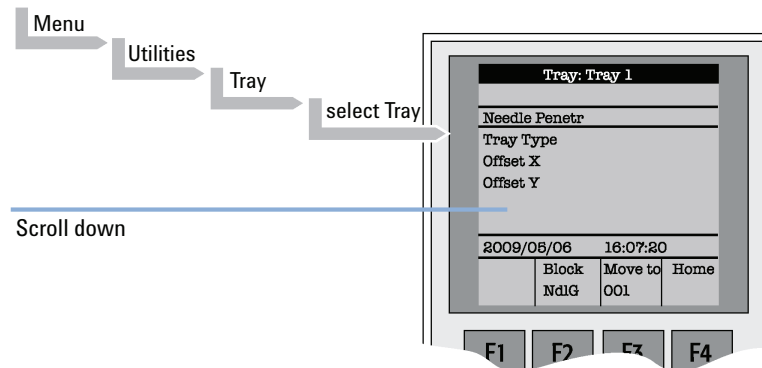
- 1 Complete the following menu selections to delete a Method.



## Job and Job Queue

A **Job** bundles the specified Tray with the designated vials (samples) and with the Method to run those samples. Another term often used for “Job” in the chromatographic field is “sequence”. If more than one **Job** is prepared, the term **Job Queue** is used.

**Before a Job can be activated the operator must verify that the Tray Type matches the specified Tray and vial size (type). This step is done in Utilities class.**

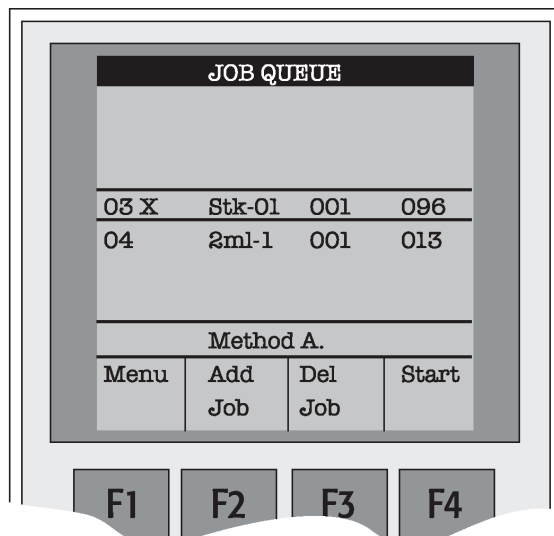


**Figure 3 Verifying Tray with corresponding Tray Type**

- 1 Select the corresponding Tray Type. By activating **F3** the injection unit can be moved to the first position and to another two corner positions to verify the correct selection of the Tray Type and teaching position.

## Building and Starting a Job Queue

- 1 Power up the module. The **JOB QUEUE** screen is displayed.



**Figure 4** Example Job Queue Screen

- 2 Load a sample Tray onto an available location in a Tray Holder. Note the corresponding Tray name.

### NOTE

If a sample Tray contains 10 ml sample vials and the "HS-Inj" cycle is used, insert the supplied adapters into the Agitator sample positions.

- 3 Add a new Job for the Tray. Press the **Add Job** key to bring up the default Job.
- 4 For **TRAY**, select the Tray name (e.g. Tray 1) that corresponds to the location of the Tray that was just loaded.
- 5 Enter the *First* and *Last* sample number for this Job.
- 6 Select and enter the sample processing *Method* for this Job.
- 7 Press the **Home** function key (**F4**) to return to the **JOB QUEUE** screen.
- 8 To add additional samples to be processed, repeat steps 2 - 7.

- 9 If necessary, replace and/or clean the syringe (liquid versions only). Press the **Menu** key to see the available options for changing (**F1 - Change Syringe**) and cleaning (**F2 - Clean Syringe**). To completely remove air bubbles, the syringe should be primed manually. (See “[Syringe Priming](#)” on page 71)
- 10 If only one Job is to be processed, select the Job with the scroll knob. Press **Start** key. In the dialog box "**Select Job(s) to Process**" select one of the following options:
  - **All** (Entire Job Queue starting from the top)
  - **Selected** (Job selected with the cursor bar)
  - **Resume** (Continue with the next Job after the one aborted)

## Aborting a Job Queue

- 1 Press **STOP**
- 2 Select one of the available options (**Continue**, **Sample**, **Job**, or **Job Queue**).
  - Select **Continue** to resume processing with the current sample.
  - Select **Sample** if there is a problem with only the current sample. Processing will resume with the next sample.
  - Select **Job** to abort processing all samples in the current Job. Processing will resume with the next Job. The aborted Job is marked with an **X**.
  - Select **Job Queue** to abort processing all Jobs. The **JOB QUEUE** screen will be displayed. The aborted Job is marked with an **X**.

## Restarting an Aborted Job Queue

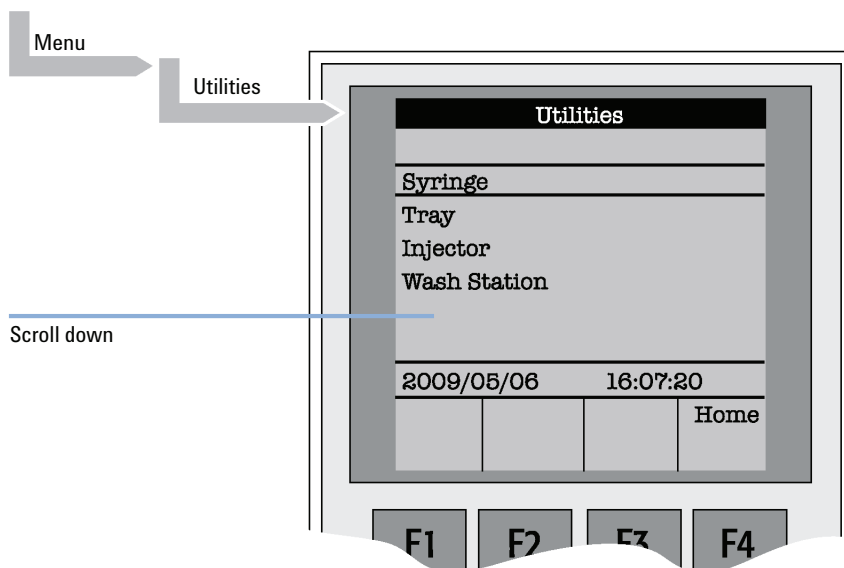
- 1 Press the **START** key.
- 2 Select the **Resume** option. The Job after the last one marked as aborted will be started.

## Utility Functions

**Utility functions**, selectable from the **Menu** screen, provide quick access to checking operations and parameters that may need to be changed. These functions are available for the actual Syringe, Trays, Injectors, and the Wash Station. They allow access to key functions without having to set up and execute a Method and Job.

**NOTE**

If an item is used in the sample processing cycle, the appropriate **Utility** value will be overwritten by the **Method** value.



**Figure 5** Selecting Utilities Functions



## Syringe

The following functions are available by pressing a Function Key:

**Table 2** Syringe - Function Key

Function Key	Description
<b>F1Chang Syr</b>	The syringe is moved to a position in which the syringe assembly can be completely lowered to facilitate removal of the syringe adapter. The syringe can then be removed from the adapter and replaced. A prompt will be displayed to specify the new syringe. The syringe must be installed before pressing <b>Enter</b> . (See "Syringes" on page 71)
<b>F2Clean Syr</b>	This Function is used to clean or prime the syringe prior to use. After selecting <b>F2</b> either <b>Wash1</b> or <b>Wash2</b> can be selected.
<b>F3Set Pos</b>	<b>Set Pos</b> is used to define the Chang Syr position
<b>F4HOME</b>	The Injection Unit moves to its <b>HOME</b> position and the <b>Job Queue</b> Menu is displayed.

The following Syringe items may be changed by selecting the particular item:

**Table 3** Syringe Items

Item	Description
<b>Actual ID</b>	Indicates the identification number (ID) of the currently inserted syringe. If the syringe detection system is set to manual, the message <b>Syringe: No syringe</b> is displayed.
<b>Fill Volume</b>	This parameter serves to control the filling of the syringe. It can occur that air bubbles remain below the plunger after the first pull up. If the plunger is moved up and down several times (see Fill Strokes), these air bubbles are worked out. With this operation the syringe can be completely filled even when using very small sample volumes.
<b>Fill Strokes</b>	Number of fill strokes. All fill strokes, except the last one, use the selected fill volume. If the selected sample volume is higher than the fill volume, the sample volume is used for all fill strokes. If zero is selected the plunger is pulled up only once using the sample volume value.

## 2 Operating Instructions

### Utility Functions

**Table 3** Syringe Items

<b>Item</b>	<b>Description</b>
<b>Pullup Del</b>	By using this item, a delay time can be selected between sample pullup and ejection while filling the syringe. When the plunger reaches the zero position during the fill strokes, the system waits half the <b>Pullup Del</b> time. This allows for an air bubble to float away from the needle tip. This feature is especially useful for removing any air bubble in the syringe and handling viscous fluids.
<b>Fill Speed</b>	Speed of plunger movement used in all syringe filling operations.
<b>Eject Speed</b>	Speed of plunger movement used in all syringe eject operations except sample injection.
<b>Inject Speed</b>	Speed of plunger movement for sample injection. Typically used for <b>Fill Strokes</b> .
<b>Plunger Chnge Pos</b>	Plunger position during <b>Change Syringe</b> operation. The syringe plunger is moved to a position where the syringe can be removed and replaced. The value may be changed for different types of syringes.

## Tray

After selecting the particular Tray to be accessed, the following functions are available:

**Table 4** Tray - Function Key

Function Key	Description
<b>F2Block NdIG</b>	<b>F2</b> activates Needle Guide blocking. The option after activation is " <b>Rel NdIG</b> ", releasing Needle Guide Blocking. It may be used to test the functionality of the solenoid that blocks the needle guide.
<b>F3Movto nnn</b>	This function serves as a quick check to determine if the X,Y,Z-coordinates are defined correctly for the selected Tray. To use this utility the selected Tray, including the sample vials, must be present. After pressing " <b>Movto 001</b> " the Injection Unit moves to sample position no.1. This procedure can be repeated for the last sample position in the first row and the last sample position.
<b>F4HOME</b>	The Injection Unit moves to its <b>HOME</b> position and the <b>Job Queue</b> Menu is displayed.

The following Tray items may be changed by selecting the particular item:

**Table 5** Tray - Items

Item	Description
<b>Needle Penetr</b>	Needle penetration depth into the sample vial. The needle penetration depth for the selected Tray can be changed by entering the desired value.
<b>Tray Type</b>	The Tray Type which is selected for the Tray is shown. If the Tray enables the use of different Tray Types it can be changed at this position.
<b>Tray Offset X</b>	If necessary, a correction to the ideal X-position of "Position 1" can be made by using " <b>Tray Offset X</b> ".
<b>Tray Offset Y</b>	If necessary, a correction to the ideal Y-position of "Position 1" can be made by using " <b>Tray Offset Y</b> ".
<b>Tray Offset Z</b>	If necessary, a correction to the ideal Z-position of "Position 1" can be made by using " <b>Tray Offset Z</b> ".

## Injector

After selecting the particular Injector to be accessed, the following functions are available:

**Table 6** Injector - Function Key

Function Key	Description
<b>F3Movto Inj</b>	The Injection Unit moves to the selected injector position. With this function, e.g. the injectors <b>LC Vlv1</b> , <b>Waste</b> and <b>Waste2</b> can be accessed. By selecting the parameter " <b>Needle Penetr</b> " on the same screen, the Injector Needle Penetration value can be checked or changed.
<b>F4HOME</b>	The Injection Unit moves to its <b>HOME</b> position and the <b>Job Queue</b> Menu is displayed.

The following Injector item can be changed by selecting the particular item:

**Table 7** Injector - Parameters

Item	Description
<b>Needle Penetr</b>	By selecting the parameter " <b>Needle Penetr</b> " the Injector Needle Penetration value can be checked and/or changed. To ensure reproducible sample injections and minimize carry-over it is critical that the needle penetration depth be accurately set.

## Wash Station

After selecting the specific Wash Station, the following Functions are available:

**Table 8** Wash Station - Function Key

Function Key	Description
<b>F3Movto Wash</b>	The injection unit moves to the selected Wash Station port. By selecting the Parameter " <b>Needle Penetr</b> " on the same screen the Wash Station Needle Penetration value can be checked or changed.
<b>F4HOME</b>	The Injection Unit moves to its <b>HOME</b> position and the <b>Job Queue</b> Menu is displayed.

The following Wash Station Parameter may be changed by selecting the particular item:

**Table 9** Wash Station - Items

Item	Description
<b>Needle Penetr</b>	By selecting the Parameter " <b>Needle Penetr</b> " the Wash Station Needle Penetration value can be checked and/or changed.
<b>Rinse Time</b>	If <b>Rinse Time</b> is activated (value > 0), the solenoid of a Fast or Active Wash Station opens for the specified time after the syringe needle has been removed from the wash port (after completion of the syringe wash cycle). The solvent flows into the wash port without the restriction of the needle; be aware of higher solvent consumption.

## Vial

After selecting the specific Vial type, the following functions are available:

**Table 10** Vial - Function Key

Function Key	Description
<b>F3Movto Vial</b>	The injection unit moves to the selected vial type. By selecting the parameter " <b>Needle Penetr</b> " on the same screen, the Wash Station Needle Penetration value can be checked or changed.
<b>F4HOME</b>	The Injection Unit moves to its <b>HOME</b> position and the <b>Job Queue</b> Menu is displayed.

**Table 11** Vial - Items

Item	Description
<b>Needle Penetr</b>	By selecting the parameter " <b>Needle Penetr</b> " the Wash Station needle penetration value can be checked and/or changed.

## Dilutors

After selecting the specific Dilutor, the following functions are available:

**Table 12** Dilutors - Function Key

Function Key	Description
<b>F1Prime</b>	The Dilutor syringe is primed with solvent after activating the <b>F1</b> function.
<b>F2Chang DSyr</b>	Activating <b>F2</b> moves the plunger of the Dilutor Syringe to standby position to allow easy access to change the syringe.
<b>F4HOME</b>	The Injection Unit moves to its <b>HOME</b> position and the <b>Job Queue</b> Menu is displayed.

The following Dilutor items can be changed by selecting the particular item:

**Table 13** Dilutor - Items

Item	Description
<b>Syringe</b>	Indicates the Dilutor side-port syringe inserted in the Z-axis. This function allows selecting another syringe size.
<b>Syr Dilut Pos</b>	Activating this function moves the plunger of the side port syringe up by the specified distance. This allows adjustment of the plunger tip of the side port syringe exactly above the lower side port (solvent inlet). This fine tuning is necessary after changing a side port syringe to allow unrestricted solvent flow.
<b>Dilutor Syr</b>	Indicates Dilutor Syringe is installed. If the syringe size is changed, this item must be adapted accordingly. The syringe-specific dimensions are coordinated by this function.
<b>Prime Volume</b>	A volume to prime the Dilutor Syringe can be specified. The allowed range can be fourfold higher than the actual syringe volume. This allows filling and emptying a dilutor syringe more often than just once.
<b>Pullup Delay</b>	Using this item permits selecting a delay time between solvent filling and ejection while filling (or priming) the syringe.
<b>Fill Speed</b>	Speed of plunger movement of Dilutor Syringe used in all syringe filling operations.
<b>Eject Speed</b>	Speed of Dilutor Syringe plunger movement used in all dilutor syringe eject operations.
<b>Eject Delay</b>	Using this item permits selecting a delay time between solvent ejection and filling while filling (or priming) the syringe.

## Tools

**NOTE**

The Object class “**Tools**” is available with GC Injector 80 Firmware level 3.0.X , 4.1.X. or higher.

After selecting the specific tool, the following functions become available:

**Table 14** Tools - Function Key

Function Key	Description
<b>F1Chk Offs</b>	The item “ <i>Check Offset</i> ” can be used to verify the offset from the syringe needle tip to the tool tip. This item is mainly used for the <b>MALDI</b> tool; it is not active for the <b>MHE</b> tool.
<b>F4HOME</b>	The injection unit moves to its <b>HOME</b> position and the Job Queue Menu is displayed.

The following tool items may be changed by selecting the particular item:

**Table 15** Tools - Items

Item	Description
<b>Teach Point</b>	The reference point at which to teach the Object ( <b>Tool</b> ; <b>MHETool</b> ) is selectable. In the case of the <b>MHETool</b> , no extra position is necessary. The Parking Station is the fix point. Select “ <b>None</b> .”
<b>ToolOffset X</b>	If necessary, a correction to the ideal X-position of the <b>MHETool</b> can be made by using “ <b>ToolOffsetXX</b> ”.
<b>ToolOffset Y</b>	If necessary, a correction to the ideal Y-position of the <b>MHETool</b> can be made by using “ <b>ToolOffsetY</b> ”
<b>ToolOffset Z</b>	If necessary, a correction to the ideal Z-position of the <b>MHETool</b> can be made by using “ <b>ToolOffsetZ</b> ” A “ <b>ToolOffsetZ</b> ” of -48 mm is necessary to position the <b>MHETool</b> on the sample vial.



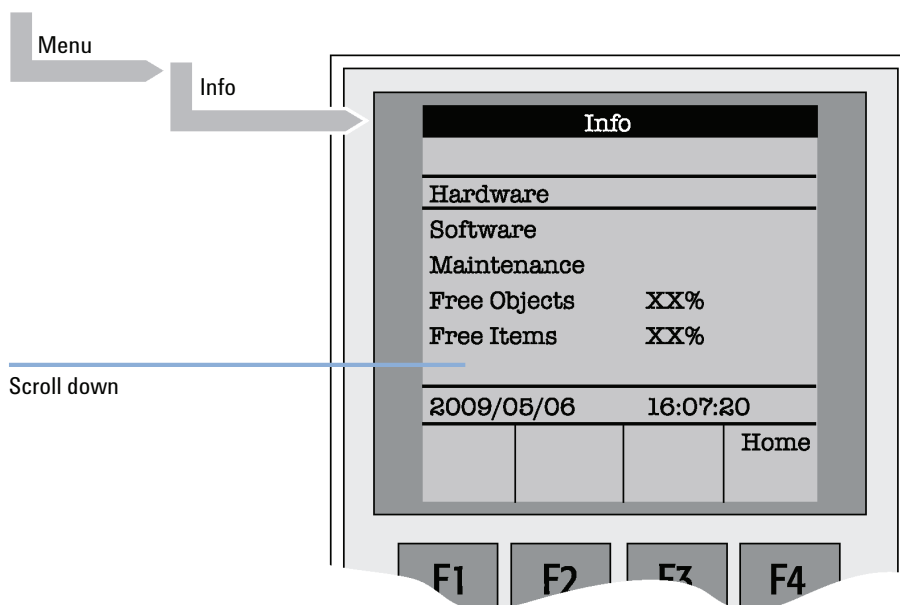
## Logfile

The GC Injector 80 logfile cannot be read-out directly on the terminal display.

However, “**F3**” does allow a print out. A serial printer has to be connected to port “SER2” for the GC Injector 80 System. If a serial printer is not available use a serial/parallel converter.

## Info Functions

Info functions, selectable from the Menu screen, provide quick access to information to be viewed. These info functions are available for the **Hardware**, **Software**, **Maintenance**, **Free Objects**, and **Free Items**. All items with the exception of “**Maintenance**” are read only.



**Figure 6** Selecting Info Functions

## Hardware

**Table 16** Hardware

<b>Item</b>	<b>Description</b>
<b>CPU SNo</b>	The serial number (SNo.) of the PCB “APR CPU” is displayed.
<b>CPU ID</b>	Version number of the PCB “APR CPU”.
<b>MOTIO ID</b>	Version number of the PCB “APR CPU”.

## Software

**Table 17** Software

<b>Item</b>	<b>Description</b>
Firmware	Firmware level of System
Head Firmware	Version level of the firmware Injection Unit
Terminal FW	Version level of the firmware Terminal
Altera Firmware	Version level of the Altera component firmware

## Maintenance

Table 18 Maintenance

Item	Description
<b>PlgStrokeCnt</b>	This is a counter for syringe plunger movements. The actual number of strokes is displayed. If the counter reaches the set limit ( <b>PlgStrokeLim</b> ) a warning is displayed at the next start of a job (run). The system continues but signals the user to verify syringe conditions. The counter can be set back to zero to restart. There is only one counter for a syringe. If syringe types are changed the system continues to count as if it were the same type.
<b>PlgStrokeLim</b>	An upper limit for the syringe plunger strokes can be set.
<b>Inject Count</b>	This counter monitors the number of injections. The number of penetrations into the GC injector is a helpful tool for the user to decide on a replacement of parts of the injector system. The actual number of injections (valve switches) is displayed. If the counter reaches the set limit ( <b>PlgStrokeLim</b> ), a warning is displayed at the next start of a job (run) ( <b>Inject Limit</b> ). The same counter is used for valve switches (HPLC technique).
<b>Inject Limit</b>	An upper limit for the number of injections can be set.

### NOTE

Counters for the plunger movement and injector penetrations are available with Firmware level 2.5.X or higher.

## Free Objects / Free Items

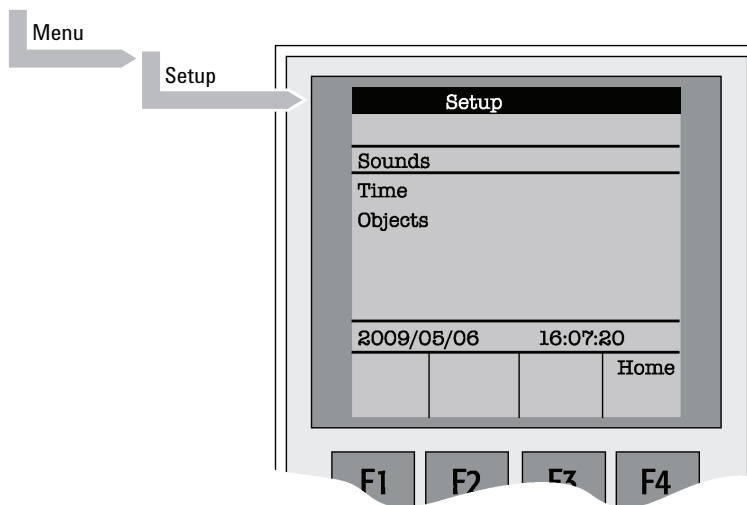
In addition to the core software, the Firmware contains data for the **Firmware Objects**. There are different classes of Objects, such as Syringes, Trays, Tray Holders, etc. Each class of Objects contains **Items**. The items contain the actual data such as X-, Y-, Z-positions.

The data are stored in a flash memory backed up by a battery. To optimize RAM and Flash memory use, a certain section of memory has been reserved by the software for each of the Objects and Object Items.

The percentage shown in the **Info** section provides an indication as to how much of the reserved software space is still available.

## Setup Functions

The **Setup** functions, selectable from the Menu screen, allow access to various functions for the sampler system. The **Sound**, **Time** and **Objects** are basic functions used at installation or if changes have been made over time.



**Figure 7** Selecting Setup Functions

## Sounds

**Table 19** Sounds

Item	Description
<b>Message Box</b>	A specific dual beep tone signals that a pop-up window (Message Box) for user intervention appears on the screen. This beep signal can be turned on or off.
<b>Warn Move</b>	A beep sound is heard at the start of the module movement. It is advisable to keep this function turned on for safety reasons.
<b>End Cycle</b>	A beep sound is heard at the end of a cycle. Select as desired.
<b>End Job</b>	A beep sound is heard at the end of a cycle. Select as desired.

## Time

**Table 20** Time - Item

Item	Description
<b>Year</b>	The year can be set for the module internal clock
<b>Month</b>	The month can be set for the module internal clock.
<b>Day of Month</b>	The day can be set for the module internal clock.
<b>Hours</b>	The hours can be set for the module internal clock.
<b>Minutes</b>	The minutes can be set for the module internal clock.
<b>Seconds</b>	The seconds can be set for the module internal clock.

After setting or resetting the date and time, use **F1**

“**Set Time**” to store.

## **Objects**

The various module Firmware Object classes can be selected and the functions most used by the user are directly accessible.

For detailed listing see “[Flow Chart based on Firmware Level 2.5.X.](#)” on page 128.





### 3

## Agilent GC Injector 80 Description and Installation

General System Overview	43
Specifications	45
Performance Specifications	45
Electrical Specifications	46
Physical Specifications	47
Operating and Environmental Requirements	47
Sound Pressure Level	48
Installation	49
Unpacking the Components	49
Assembling the Agilent GC Injector 80	50
Electrical Connections	58
Object Positions	59
Defining Object Reference Positions	59
Description of Object Reference Positions	62
Syringes	71
Selecting Syringes	71
Syringe Priming	71
Installing a Syringe	72
Removing a Syringe	74
Interfacing the GC PAL to other Devices	75
Synchronization and Output Signals	75
Loader Program	78
Special Functions	79
How to Access “Extended User Mode”	79
Section “F3-Setup”	80
Section “F3-Setup” / Objects	86



### 3 Agilent GC Injector 80 Description and Installation

#### Setup Functions

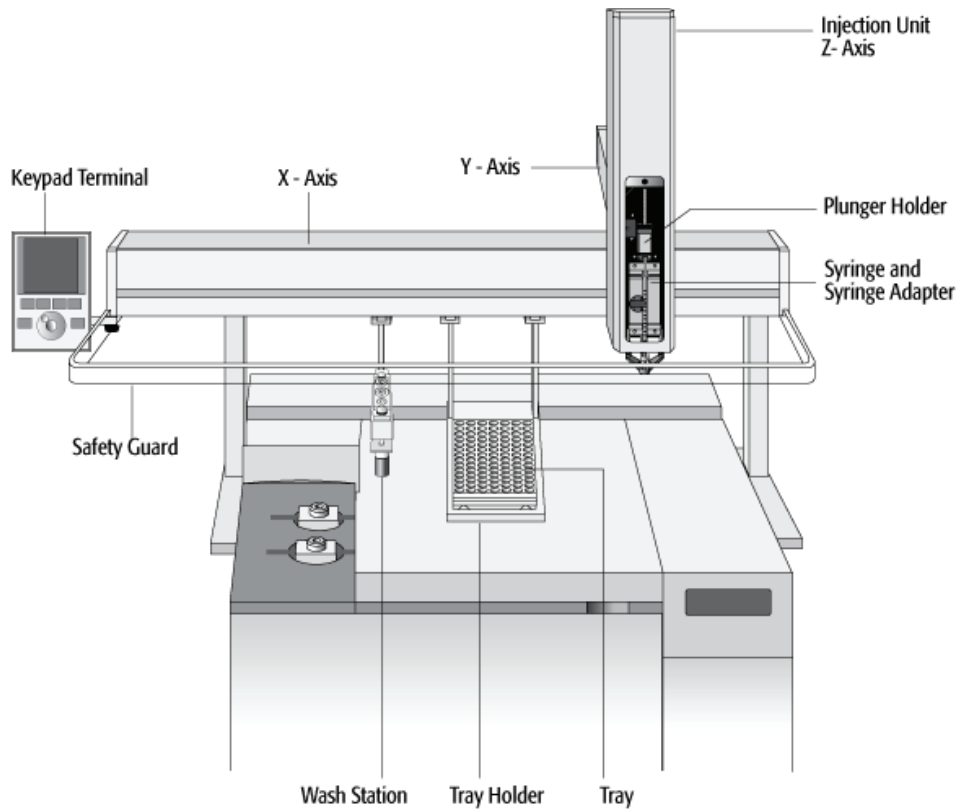
Troubleshooting	99
No or very low detector signal is observed.	99
Syringe does not fill properly.	100
Sample peaks/responses are not reproducible.	100
Excessive carryover between samples	101
Unexplained collisions of the Injection Unit.	101
“Object Not Detected” (Object e.g. Tray1, LCVlv1, Stk1- 01)	102
Invalid Motor Status Motor Aux.	102
Replacing Parts	103
Warnings and Cautions	103
Control Board	104
Injection Unit	106
Maintaining the Autosampler System	107

This chapter gives an overview and information about the installation of your Agilent GC Injector 80 System.

## General System Overview

**NOTE**

Agilent reserves the right to make improvements and/or changes to the product specifications without notice.



**Figure 8** GC Injector 80 Major System Components

### 3 Agilent GC Injector 80 Description and Installation

#### General System Overview

The standard GC Injector 80 includes the following hardware:

- 1 X-, Y-axes assembly
- 1 Injection Unit, Z-axis
- 1 Tray Holder/Tray for 1 ml / 2 ml vials
- 1 10 µl Syringe Kit for liquid injections
- 1 Wash Station with 2 x 10 ml Wash, 2 x 10 ml Waste and 1 x 10 ml Standard Vials
- 1 Keypad terminal
- 1 Safety guard
- 1 GC mounting kit (optional)

## Specifications

### Sample Capacity

- 98 x 2 ml vials per Tray
- 200 x 1 ml vials per Tray
- 32 x 10 ml / 20 ml vials per Tray (up to three Trays can be configured)
- 108 x 2 ml vials per Stack Cooler 2 DW (2 x 54 vials)
- 216 x 2 ml vials per Stack 4 DW (without cooling/heating)
- 2 Micro-Deepwell plates per Stack Cooler 2 DW
- 4 Micro-Deepwell plates per Stack 4 DW

### Thermostatted Sample Tray

- Tray Cooler, optional, 4 °C – 70 °C
- Stack Cooler 2 DW, optional, 4 °C – 40 °C

### Liquid Injection Range

- 1 µl – 10 µl with standard 10 µl syringe
- Down to 0.1 µl with sandwich technique or
- Optional 1.2 µl syringe
- Up to 50 - 500 µl with optional 500 µl syringe

### Replicate Injections

- 1 – 99 from one vial

### Minimum Sample Volume

- 1 µl from a 3 µl sample in 1 ml tapered micro vial in liquid injection mode

## Performance Specifications

The performance specifications are available as part of a specific, separate document.

## Electrical Specifications

**Table 21** Electrical Specifications

<b>Parameter</b>	<b>Requirement</b>
Protection Class <sup>1</sup>	Class I
Over Voltage Category <sup>2</sup>	Category II
Pollution Degree <sup>3</sup>	2
Moisture Protection <sup>4</sup>	Normal (IPX0)
Voltage	36 VDC
Current	3.2 A
Fuse	T6.3 A/250 V
<b>System Power Supply</b>	
Input line voltage	Grounded AC, 100 to 240 V
Input line frequency	50 /60 Hz
Input power	4 A
Output voltage	36 VDC
Output current	4.16 A

<sup>1</sup> Protection class describes the insulating scheme used in the instrument to protect the user from electrical shock. Class I identifies a single level of insulation between live parts (wires) and exposed conductive parts (metal panels), in which the exposed conductive parts are connected to a grounding system. In turn this grounding system is connected to the third pin (ground pin) on the electrical power plug.

<sup>2</sup> Over Voltage category II pertains to instruments that receive their electrical power from a local level such as an electrical wall outlet.

<sup>3</sup> This is a measure of pollution on electrical circuits that may produce a reduction of the dielectric strength or surface resistivity. Degree 2 refers to normally only non-conductive pollution. Occasionally, however, a temporary conductivity caused by condensation must be expected.

<sup>4</sup> Normal (IPX0) – IPX0 means that there is NO Ingress Protection against any type of dripping or sprayed water. The X is a place holder to identify protection against dust if applicable.

## Physical Specifications

**Table 22** Physical specifications

Parameter	Requirements
<b>GC Injector 80 Systems</b>	
Height	598 mm (23.5 in)
Depth	385 mm (15.2 in)
Width	828 mm (32.6 in)
Weight	10 kg (22 lbs.) without accessories

## Operating and Environmental Requirements

**Table 23** Operating and Environmental Requirements

Parameter	Requirements
Operating Temperature Range	4 to 40 °C (39 to 104 °F)
Maximum Relative Humidity	75 %, non-condensing
Bench Space	At least 16 cm (6 in.) at the rear. Access to power switch(es) and power cord(s). Clean, level and smooth surface. Solid bench plate.
Vibration	Negligible
Static electricity	Negligible

## Sound Pressure Level

**Table 24** Sound Pressure Level

<b>Parameter</b>	<b>Requirements</b>
Sound Pressure Level	Measured value: 62 dBA <sup>1</sup> (PAL System used for measurement) One meter from the equipment in the direction of maximum sound pressure level. According to UL 610107A-1, 1st edition, clause 12.5. Limit < 85 dBA

<sup>1</sup> dBA = "A weighted" sound pressure level



## Installation

### Unpacking the Components

A GC Injector 80 system is shipped in one box. The box contains the X-, Y-axes assembly, the Injection Unit, the Keypad Terminal, connecting cables, power supply, Syringe kit, Tray Holder, Tray, Wash Station assembly, Safety Guard and miscellaneous parts.

Optional parts, such the GC Mounting kit, Stacks, SPME Option, etc. are normally packed in a separate box.

- 1** Open the box and first remove the accessory boxes and the Injection Unit before attempting to remove the X-, Y-axes assembly.
- 2** Carefully lift the X-,Y-axes assembly and remove it from the box. Hold the Y-axis in place while the assembly is being removed from the box. Set the X-,Y-axes assembly on a bench.
- 3** Unpack the remaining small boxes and any other accessories.
- 4** When placing the sampler onto a GC, make sure that no objects interfere with either the Y-axis or the Injection Unit throughout the entire range of potential movement.

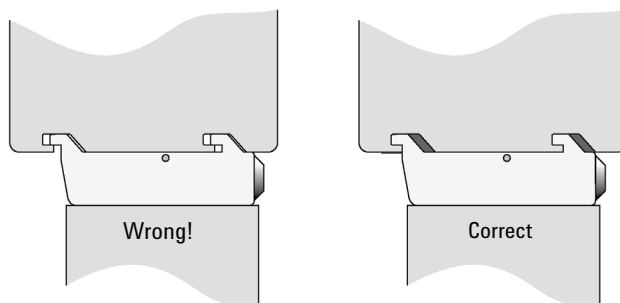
## Assembling the Agilent GC Injector 80

- 1 Mount the correct GC mounting kit onto the GC.
- 2 Loosen the two mounting clamp Torx screws of the vertical legs.
- 3 Place the X-, Y-axes assembly on top and fit the mounting kit legs into the groove in the X- axis. Be sure that the clamps fit completely into the grooves.

OR

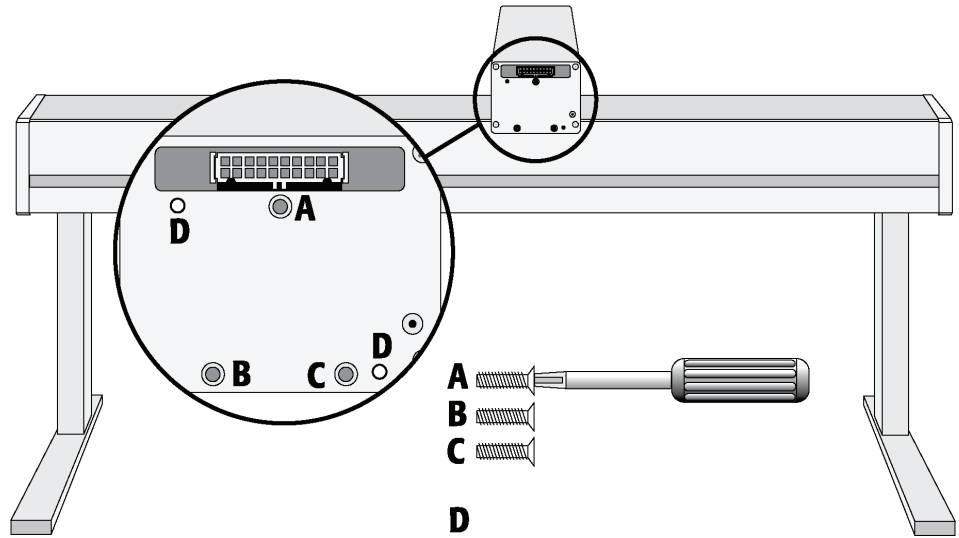
Alternately tighten the two Torx screws until the legs are firmly in place.

- 4 Double check whether the leg claws are correctly attached to the X-axis (see [Figure 9](#) on page 50).



**Figure 9** Attachment of Mounting Claws

## Installing the Injection Unit



**Figure 10** Attaching the Injection Unit (shown freestanding for clarity)

### NOTE

Installation of the Injection Unit should be done carefully. When installing it for the first time, have someone hold it in place while the mounting screws are inserted.

### NOTE

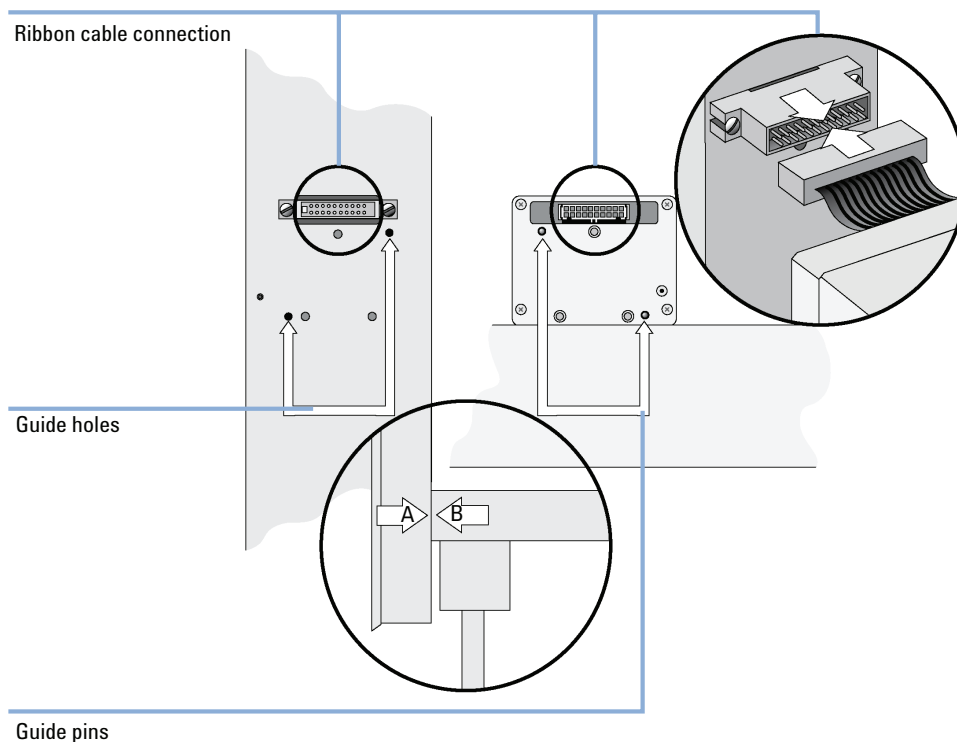
Depending on the GC module and its dimensions, it is advisable to install the Injection Unit (Z-axis) first, before the autosampler is fixed on the GC with the mounting kit. The slider may not be able to extend fully due to horizontal GC-surface interference (Y-axis not long enough to avoid surface).

- 1 Remove the three Torx mounting screws *A*, *B*, and *C*, used to fix the Injection Unit to the Y-axis

### 3 Agilent GC Injector 80 Description and Installation

#### Installation

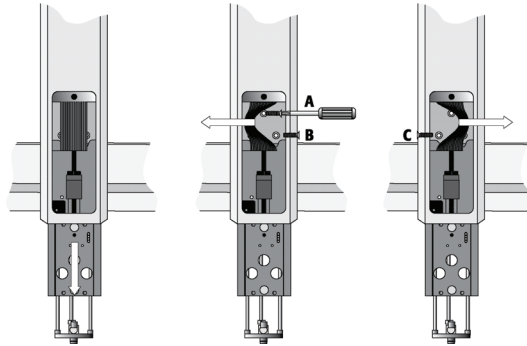
2 Connect the ribbon cable (see [Figure 11](#) on page 52).



**Figure 11** Connecting the Injection Unit Ribbon Cable

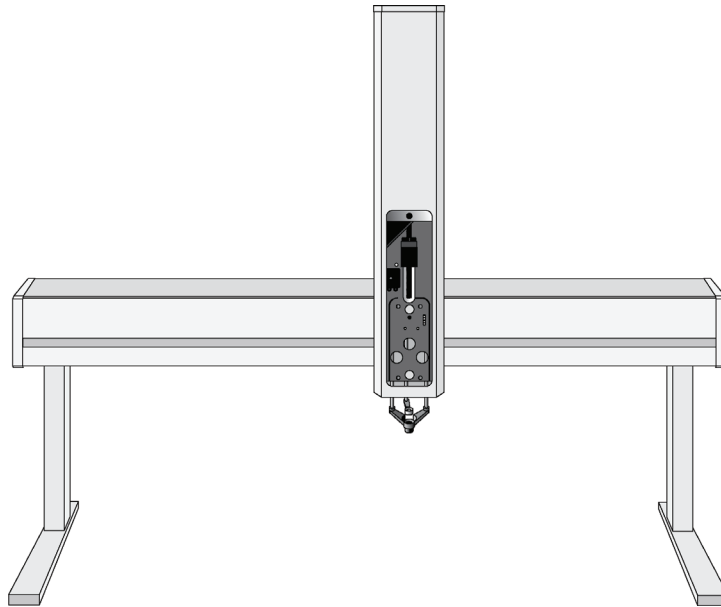
- 3 Hold the Injection Unit in place against the Y-axis. Make sure the two locating pins on the Y-axis fit into the two guide pin holes on the Injection Unit.
- 4 Position the Injection Unit to the left or right end of the X-axis. The extended Injection Unit will be lower than the GC top cover. Extend the slider of the Z-axis to the full stop. Locate the three large holes behind the ribbon cable, above the black anodized frame (slider) in the back- panel of

the axis. Place one of the screws onto the end of the supplied Torx driver. Insert the and securely tighten the Torx screw A (see Figure 12 on page 53).



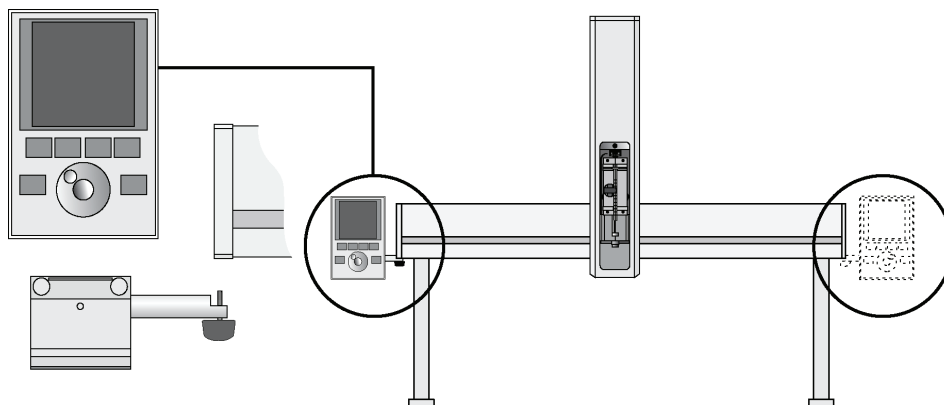
**Figure 12** Inserting the Injection Unit Mounting Torx Screws

- 5 Install the two remaining Torx screws *B*, *C* in the left and right mounting holes, respectively. It may be necessary to move the elastic cord slightly to the left to insert the Torx screw *C* into the right-hand hole.



**Figure 13** GC Injector 80 with Injection Unit and Standalone Supports

### Installing the Keypad Terminal and Safety Shield



**Figure 14** Installing Keypad Terminal

- 1** Install the safety shield on the left and right sides to the outside of the X-axis. Use the provided, longer thumbscrew on the side where you plan to install the keypad.
- 2** Install the Keypad mounting bracket on either the right or left side of the X-axis.
- 3** Connect one end of the white coiled cable (Part No. SS8J-700) to the Keypad and the other end to the TERMINAL (SER3) interface jack on the rear side of the X-axis. For details see “[Electrical Connections](#)” on page 58.
- 4** Place the Keypad terminal onto its mounting bracket.

## Installing the Power Supply

- 1 Locate the power supply, the DC power cable, and the AC power cable.
- 2 Set the power supply switch to the *OFF* position.
- 3 Connect one end of the DC power cable to the power supply and the other end to the *POWER* connector at the rear side of the X-axis.
- 4 Connect the female end of the AC power cable to the power supply. Then connect the male end to an AC power outlet.

### NOTE

Before proceeding with the remaining steps, make sure the power to the Autosampler System is switched off.

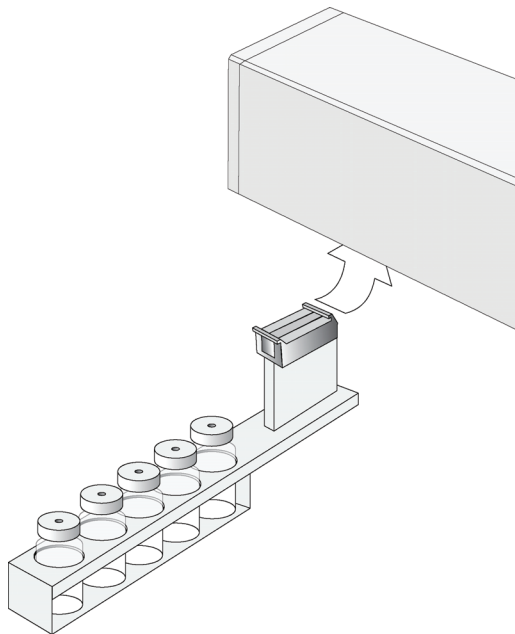
---

### 3 Agilent GC Injector 80 Description and Installation

#### Installation

#### Installing the Wash Station

- 1 Attach the Wash Station assembly to the X-axis.



**Figure 15** Installing the Wash Station

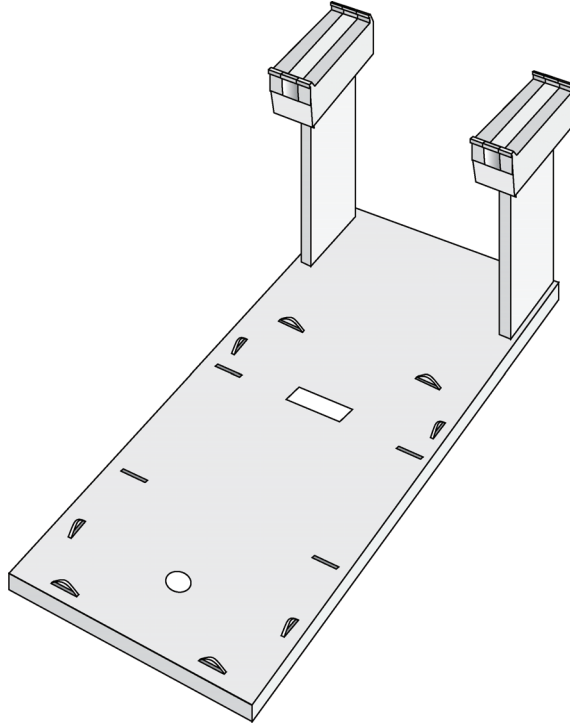
#### NOTE

Other types of wash stations, such as Fast Wash Station or Active Wash Station, cannot be installed on the GC PAL system. The Control-GC board does not provide an electrical connector for these types of wash stations.



## Installing a Trayholder

- 1 Loosen the two Torx screws on the two mounting clamps located on top of the Tray Holder legs.



**Figure 16** Installing a Tray Holder

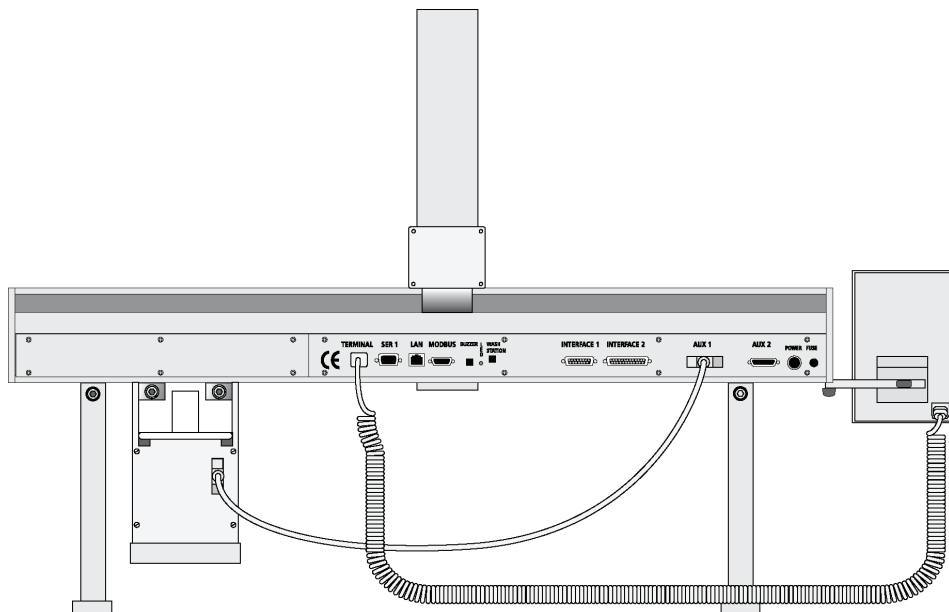
- 2 Install the Tray Holder with the mounting clamp teeth fitting into the grooves on the bottom of the X-axis.
- 3 Be sure that the clamps fit completely into the grooves. Alternately tighten the two Torx screws until the two mounting clamps are firmly in place.
- 4 Double check if the two Tray Holder clamps are correctly attached to the X-axis.

## Electrical Connections

**NOTE**

Always switch OFF the module power supply before connecting or disconnecting any accessories cable!

- 1 Before defining the module object positions, make sure the Keypad Terminal is correctly connected to the module X-axis rear side (see Figure 17).

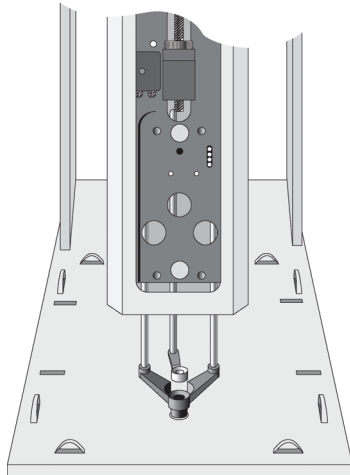


**Figure 17** Electrical Connections for GC Sampler

## Object Positions

### Defining Object Reference Positions

The objective is to define the Reference Positions for all autosampler Objects. Make sure the Tray Holder(s), Agitator and Wash Station are properly mounted to the autosampler X-axis. The following description is an example of how to teach the reference position for a Tray Holder. The described procedure is common to all autosampler Objects.



**Figure 18** Object Reference Position

#### NOTE

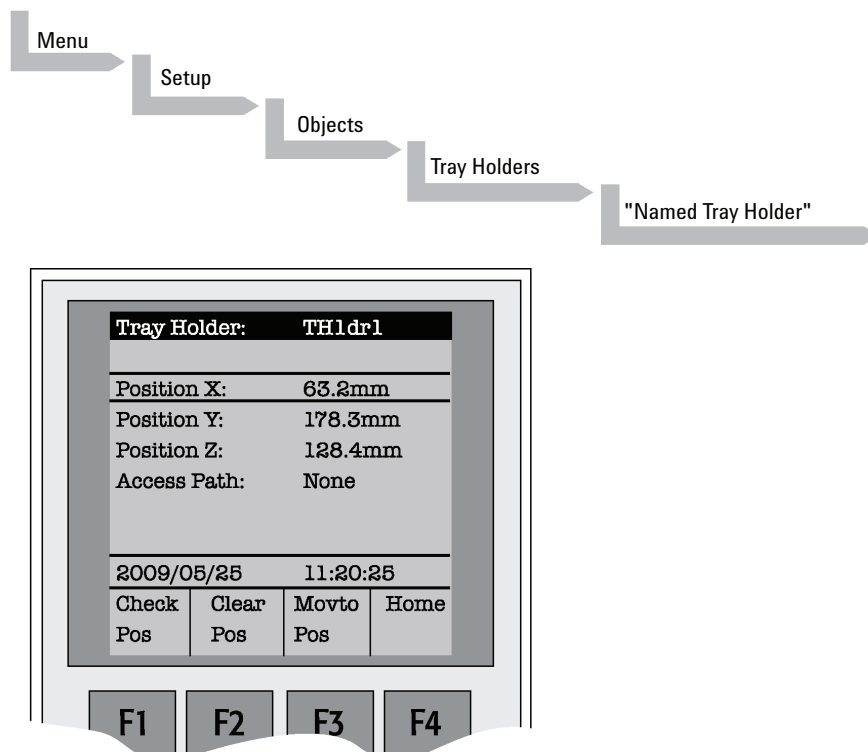
Remove the Syringe Adapter from the Injection Unit before performing the following steps.

For a Tray Holder, the *Reference Position* is a hole (slightly larger than the lower needle guide) in the base plate of the holder. The lower needle guide should be centered in the hole with the bottom of the needle guide flush with the bottom of the base plate (see [Figure 18](#) on page 59).

### 3 Agilent GC Injector 80 Description and Installation

#### Object Positions

- 1 Switch ON the autosampler power supply.
- 2 Observe the keypad display. The model name will display along with the software version number. The **Job Queue** menu screen will then display.
- 3 When the "**Job Queue**" menu displays, complete the following sequence (common to all objects):



**Figure 19** Menu Screen Object Trayholder

---

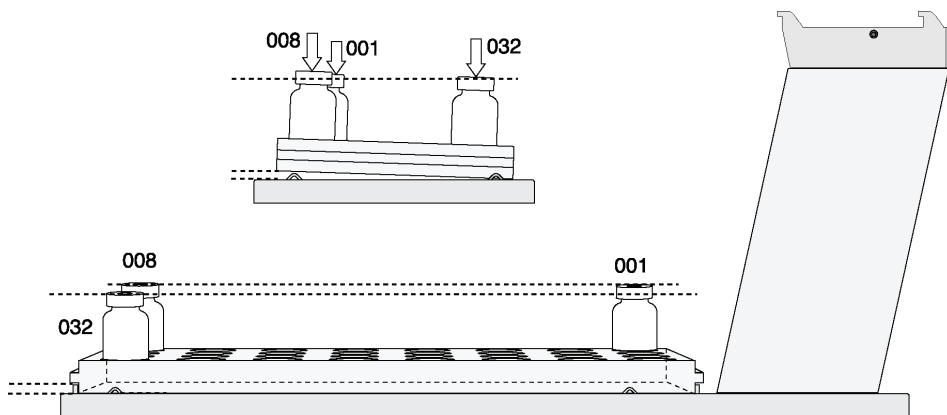
1 "**Named Tray Holder**" represents a predefined Tray Holder, (e.g. TH1dr1).

---

- 4 After selecting "**Named Tray Holder**" the X- Y- Z-positions for the object will be displayed (see [Figure 19](#) on page 60).
- 5 Highlight item **Position X** with the cursor bar and press **ENTER**. The Injection Unit will move to the previously defined X-axis position.

- 6 Rotate the outer knob to adjust the X-axis position to the Tray Holder reference position.
- 7 Press the inner knob to *ENTER* the **Position X** value.
- 8 Repeat steps 5-7 for **Position Y** and **Position Z**.
- 9 If **F3 "Moveto Zero"** is activated, the Injection Unit will move to the **HOME** position;
- 10 Verify the defined **X-, Y-, Z-positions** by pressing **F1 "Check Pos"**.

Figure 20 on page 61 illustrates possibilities of correction. Details for teaching are given below.



**Figure 20** Inclined Tray, Corrections for X-, Y-, Z-Axes

**NOTE**

Firmware level 3.0.X permits correcting for an inclined surface, for example a Tray Holder or Tray where the Z-axis position in front differs from the rear position. For applications such as the PAL MALDI Option, perfect alignment of the MALDI tip is vital. This compensation for the Z-axis position is provided in the firmware class **"Tool"**.

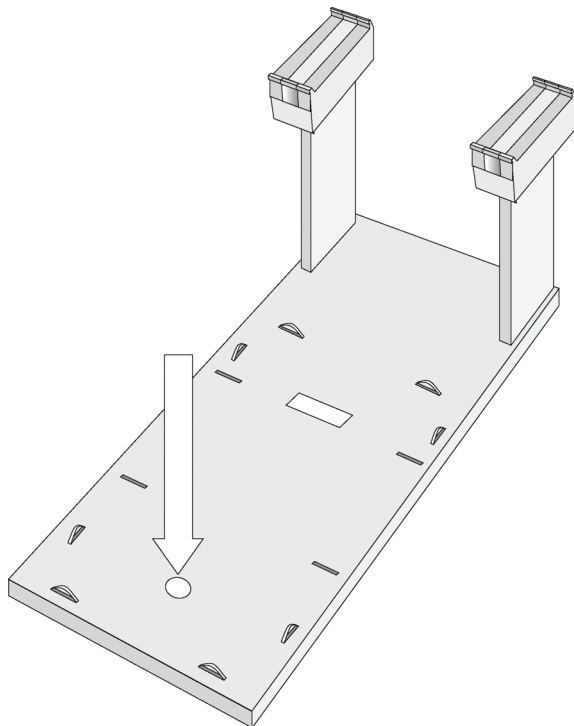
For the device **"PAL MHE Tool"** the PAL Firmware Object Class **"Tool"** is also required. See specific Addendum to PAL User Manual.

Note that these functions are not available for the injector. The injector is operated solely on PAL Firmware level 2.4.X or higher, but neither with firmware level 3.X.X. nor with level 4.X.X.

Figure 20 on page 61 illustrates possibilities of correction.

## Description of Object Reference Positions

### Trayholder (e.g. THldr1)



**Figure 21** Tray Holder Reference Position

For Tray Holder, the *Reference Position* is a hole in the base plate of the Holder. The lower needle guide should be centered in the hole with the bottom of the needle guide flush with the bottom of the base plate.

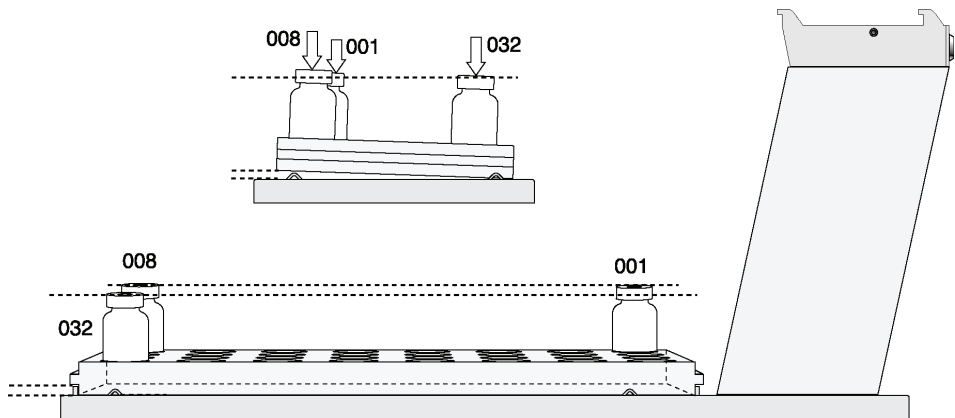
Figure 21 on page 62 shows the example of a Tray Holder for a single Tray, e.g. "THldr1" for "Tray 1" with Tray Type "VT98".

## Trays

In general it is not necessary to teach a Tray position. The Tray Holder has a teaching position, as described above. A Tray is assigned to the Tray Holder. The numbers (values) for the relevant items are stored in the firmware object “Tray”. To complete the combination of a Tray Holder and a Tray, it is necessary to assign the corresponding “Tray Type” to the “Tray.” The “Tray Type” contains the geometric data for the Tray and information, such as how many samples are in a row and a column in the Tray. A Tray Type defines the pattern and sampling sequence of sample location within a Tray. For details, see below.

As described above, the Tray is physically placed in the Tray Holder, the firmware assigns the Tray to the Tray Holder and the Tray Type to the Tray. This is routine procedure as long as no special circumstances need be considered, such as customized Trays or Tray Types.

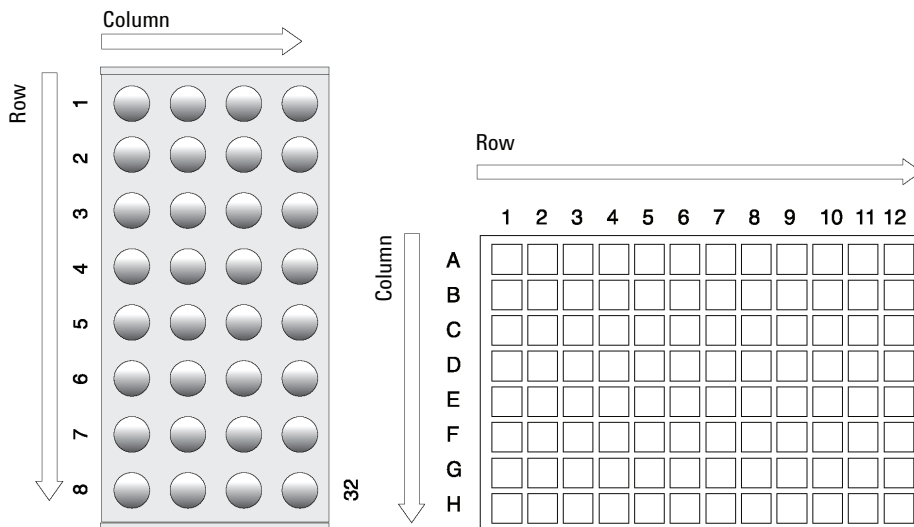
Autosampler Firmware level 4.1.X now makes a correction possible if the Tray surface is not exactly horizontal and planar but is inclined in one or more axes. At level 4.1.X this is standard and a dialog window pops up the moment the Tray has been checked-out at the corners to verify vial positions and heights. How to correct a possible inclination is explained below.



**Figure 22** Demonstrating a possible Inclination of Tray in X-, Y-, Z-Axes.

### Definition of a Tray Row and Column

The autosampler system defines Rows and Columns by the order in which samples are treated. A “Row” is not associated with an X- or Y-axis. The definition is visualized below with Tray Type VT32 and DW96:



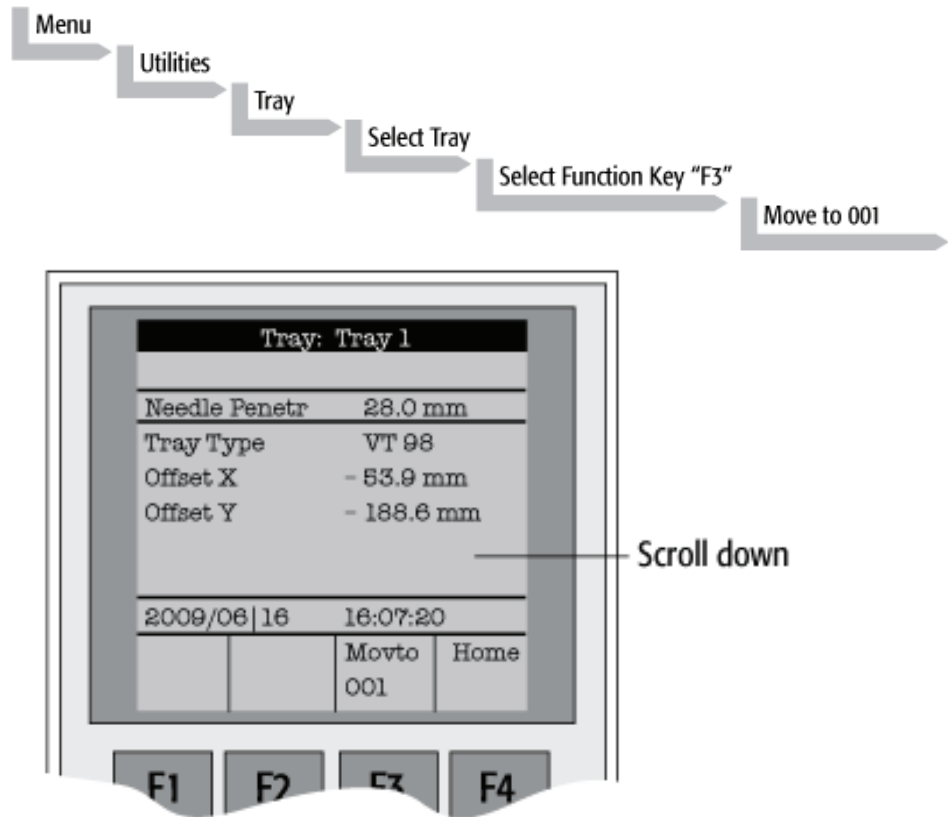
**Figure 23** Tray Type VT32 and Tray Type DW96



### Correction for Sample Position in X-, Y- or Z-Axes

The following description of the correction is done by using the path to the “Utilities” section.

After selecting the Utilities function “Trays”, verify whether the Tray Type assigned corresponds to the Tray placed into the Tray Holder. If this is verified, the vial positions can be checked at the three corners of the Tray. This is activated by the “F3” function key.



**Figure 24** Adjusting “Offset X,Y,Z” for Tray Position 001

### 3 Agilent GC Injector 80 Description and Installation

#### Object Positions

The Injection Unit moves to Tray position no. 001. With the help of the inserted syringe is it possible to check the optimized position of the needle tip matching with the vial or well position. In case the position is off, make corrections in X-, Y- or Z-positions.

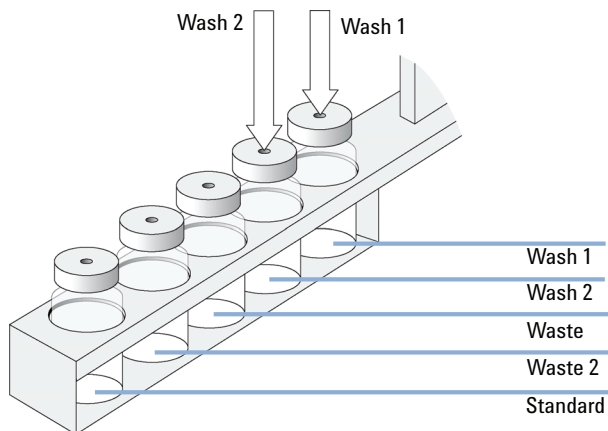
Continue with function key “**F3**” to move to the next corner to verify this position. If the position matches, continue with function key “**F3**” to move the unit to the third corner position. If a deviation of the ideal position is observed in second or third corner, the corrections have to be made on the position no. 001. The offset is bound to position no. 001.

#### NOTE

Activating one of the parameters Offset X-, Y-, or Z-axis at the positions of second or third corner can bend the syringe needle.

---

### Wash Station: Wash1/Wash2 Reference Point



**Figure 25** Wash Station Wash1/Wash2 Reference Point

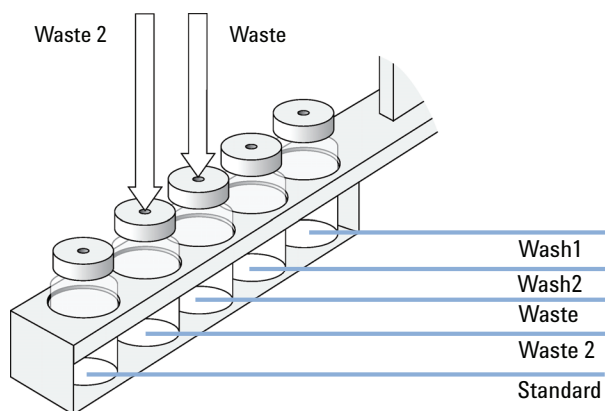
For the Wash Station, the reference positions are the two holes in the wash vial caps (see [Figure 25](#) on page 67, Wash1 and Wash2). The lower needle guide should be centered in these holes with the bottom of the lower needle guide lightly touching the surface of the caps.

### Wash Station: Waste/Waste2 Reference Point

**NOTE**

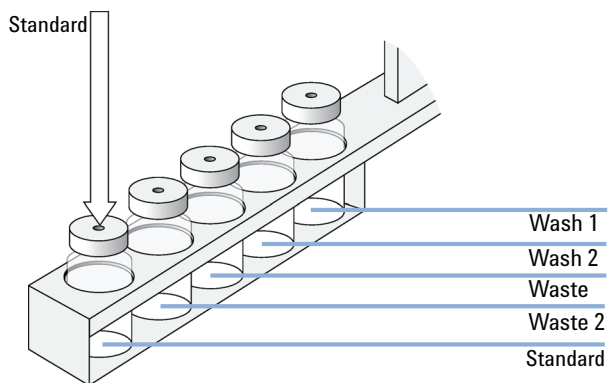
The Waste positions represent an "Injector" within the autosampler software. It is defined in the Object class "Injectors".

For Waste / Waste2 the reference positions are the two holes in the wash vial caps (see [Figure 26](#) on page 68). The lower needle guide should be centered in these holes with the bottom of the lower needle guide lightly touching the surface of the caps.



**Figure 26** Wash Station Waste/Waste2 Reference Position

### Vials (e.g. "Standard" Position in Wash Station)



**Figure 27** Wash Station Standard Reference Position

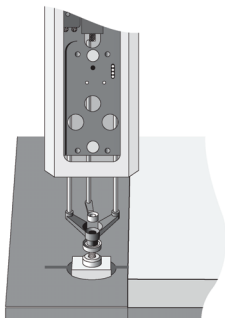
The position "Standard" on the Standard GC Wash Station is defined in the autosampler Firmware class "Vials". This position can be used for a standard, an internal standard, a reagent solution, a calibrator solution or any other type of solution. The advantage to the user is that a large quantity of solution is available and can be defined by "Job" (conventionally known as "Sample List" or "Sequence" in other systems).

The reference position is the hole in the vial cap. Teaching this position is identical for Wash or Waste vials.

### 3 Agilent GC Injector 80 Description and Installation

#### Object Positions

#### Injectors (e.g. GC-Inj1)



**Figure 28** GC Injectors (e.g. GC Inj1) Reference Position

#### NOTE

For certain GC models, centering rings are provided with the GC mounting kit. If such a centering ring is available, it should not only be used for teaching the injector position but also for routine work. The ring stabilizes the needle guide of the autosampler Injection Unit at the moment of needle penetration. It acts as a guide tool and prevents needle bending.

For the GC Inj1 (GC Inj2) the reference position is the appropriate GC Injection port. The lower needle guide should be centered on the port with the bottom of the lower needle guide lightly touching its surface.

#### NOTE

After all positions have been set, perform a firmware backup of the existing configuration by using the PAL Loader software. For instructions, see “[Loader Program](#)” on page 78.

# Syringes

## Selecting Syringes

The standard GC Injector 80 is shipped with one syringe kit:

p/n	Description
G6500-60012	GC Syringe Kit, 10 $\mu$ L Consisting of: 1 pc syringe adapter 1 pc plunger holder 2 pcs Syringe (p/n G6500-80116)

The supplied syringe kits cover the standard liquid and GC injection technique. However, certain applications may require different syringe sizes. Consult *"GC PAL Accessories"* for details.

## Syringe Priming

It is critical that syringes be primed before beginning sample preparation. Prime every liquid syringe first manually before inserting into the PAL system. Afterwards, the syringe can be primed and tested by using the Utility function **"Clean Syr"**.

## Installing a Syringe

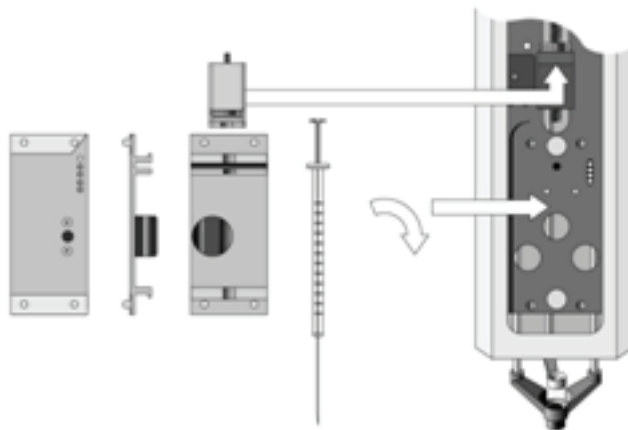
### NOTE

Before a syringe is inserted, the position “**Change Syr**” should first be verified. The position “**Change Syringe**” should not be located above an object where the needle could collide with a vial, as for example.

Path: **Menu > Utilities > Syringe > function key “F3” “Change Pos”**.

Move the Injection Unit to a location where a collision cannot occur by selecting the X- and Y- axes. The value for the Z-axis is given as a default and a change of this position is not necessary in standard operation.

- 1 Select **Menu** and press **F1/Chang Syr**. The Injection Unit will move to a location that will facilitate installation of the syringe.
- 2 Place the blue plunger holder into the injection unit.
- 3 Place the syringe in the appropriate syringe adapter. Pull the plunger out to approximately 20 % of it's length (see [Figure 29](#) on page 72).



**Figure 29** Syringe and Syringe Adapter for Liquid Injections

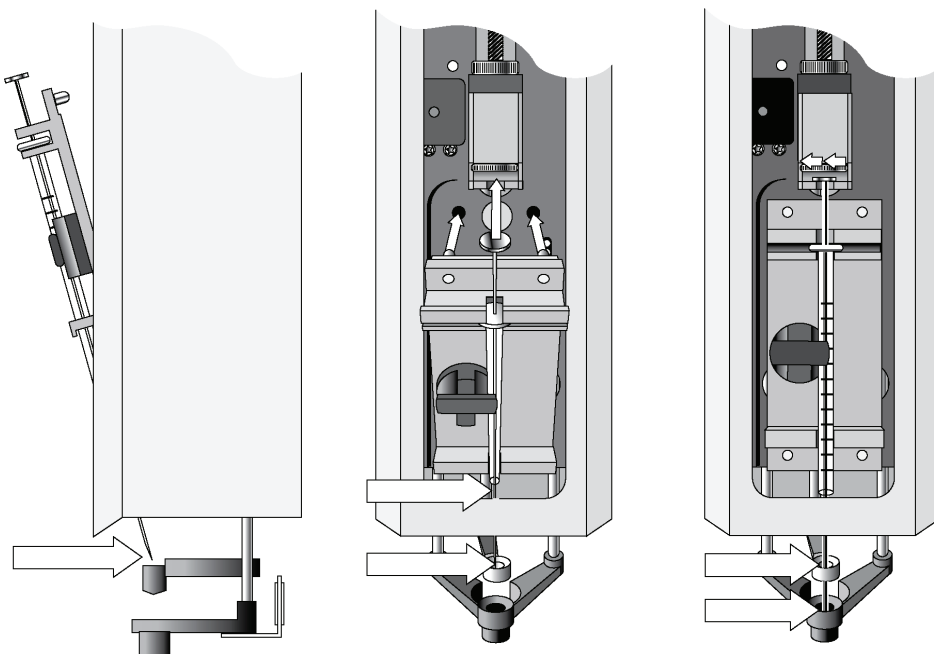
- 4 If necessary, loosen the plunger retaining screw in the plunger holder.
- 5 Move the syringe, installed in the syringe adapter, partially into the Injection Unit. First, guide the needle into the upper needle guide and then into the lower needle guide (see [Figure 30](#) on page 73).
- 6 Insert the plunger button into the plunger holder. Allow the syringe adapter to "click" into place by magnetic force against the syringe carrier.



7 Tighten the plunger retaining screw against the plunger button.

8 Press "Home".

The plunger moves down until it hits the mechanical stop. This position is stored as the syringe's zero volume position. The Injection Unit then returns to the *HOME* position.



**Figure 30** Installing and Removing a Syringe for Liquid Injections

## Removing a Syringe

- 1** Select "**Menu**" and press **F1/Chang Syr**. The Injection Unit will move to a location that facilitates removal of the syringe.
- 2** Loosen the plunger retaining screw. Move the plunger slightly out of the plunger holder.
- 3** Pull the syringe adapter out and then carefully upward to remove the syringe adapter, with the syringe, from the Injection Unit.

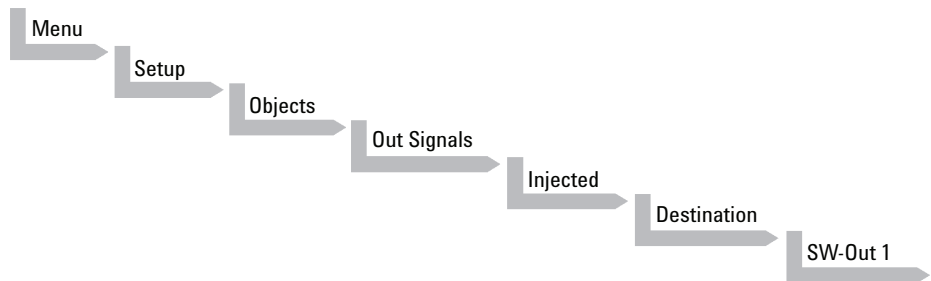
## Interfacing the GC PAL to other Devices

### Synchronization and Output Signals

Synchronization Signals (**Sync Signals**) are inputs that tell the module when to wait or proceed with a sample-processing step. Output Signals (**Out Signals**) are sent from the module to external devices to indicate status or completion of particular processing steps. These signals are classified as Objects. Physical Events (e.g. TTL-In1) are also Objects and may be assigned to named signals. Module Cycles require that certain signals such as "**Start**", "**Inject**", and "**Injected**" be defined.

See [Table 25](#) on page 76 for the GC Injector 80 Events and signal assignments associated with the standard GC Injector 80 "**GC-Inj**" and "**GC-Dual**" cycles.

Certain types of integration of the system into data handling or control software, such as ChemStation, Masshunter or EZChrom accomplish synchronization of the Ready/Start signal directly via software control (RS232/LAN). A synchronization cable is not required and the Sync Signal **Start** must be set to **Immediat**.



To assign a physical Event (e.g. SW-Out 1) to an existing signal Object (**Injected**) complete the following menu selections:

System is shipped with all Cycle events pre-defined as shown in the table below. If a different physical signal needs to be used, then it will be necessary to assign a new Event to the Object signal.

### 3 Agilent GC Injector 80 Description and Installation

#### Interfacing the GC PAL to other Devices

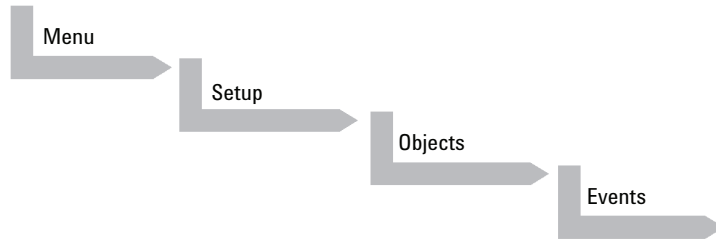
If a signal is to be ignored, then its corresponding Event must be set to **Immediat**.

**Table 25** Standard Assignment for Module Injection Cycles

Standard Assignment for Module Injection Cycles	Description	Default Events	INTERFACE1 Pin #
<b>Start JobQueue</b> (Sync Signal)	Start a Job Queue (Job). Prerequisite is a defined <b>Job</b> with a method assigned. Useful for automated, unattended, timed sampling.	Immediate	
<b>Start</b> (Sync Signal)	Start a cycle (Input from LC or data system)	TTL-In1	7 8(GND)
<b>Start2</b> (Sync Signal)	Continue the cycle <b>GC-Dual</b> for the second sample	Immediate	
<b>Inject</b> (Sync Signal)	Inject READY to INJECT	Immediate	
<b>Inject2</b> (Sync Signal)	Inject the second sample for GC-Dual cycle	Immediate	
<b>Injected</b> (Out Signal)	Activated at the moment the sample has been injected	SW-Out1	3 4
<b>Injectd2</b> (Out Signal)	Activated at the moment the second sample has been injected	Off	
<b>Prepare</b> (Out Signal)	Sends a signal to the GC prior to injection to turn off the Inlet Purge Flow.	SW-Out2	5 12
<b>Running</b> (Out Signal)	Active as long as the Job Queue is being processed and the system is not in an error state	Off	

Pins 4 (SW-Out1 Common), 8 (Ground) and 12 (SW-Out2 Common) are tied together in the Remote Cable (G6500-82013).

If an item of the class **Sync Signal** is assigned to an output signal, such as **TTL-In1**, then this TTL contact must be defined as either **Active High** or **Active Low**, as expected by the GC system. This is defined in the Firmware class **Events**.



Select the corresponding item and set the mode accordingly.

The setting is provided with the schematic description of the GC Sync Cable supplied with the specific GC Mounting Kit.

## Loader Program

The purpose of PAL Loader Software is to create a backup file of the complete PAL System Firmware. The core software (firmware) and all PAL Firmware Objects, including all settings (Items), the local methods, and jobs are saved in one file.

The system requires PAL Loader software, “Loader” version 2.1.X or higher, and PAL Firmware 4.1.X or higher. Earlier revisions of the loader software and of the PAL firmware are not compatible. .

### NOTE

The new PAL Loader Software is backwards compatible. The software can be used for all PAL Firmware levels.

---

The name of the \*.exe file has been changed intentionally to avoid conflicts when old and new versions are installed on the same computer:

- PAL Loader version 1.1.1: PALLOAD.exe  
PAL Firmware level up to and including 3.X.X
- PAL Loader version 2.1.X: Setup PALloader (.exe)  
PAL Firmware level as of 4.1.X but backwards compatible with lower levels

## Special Functions

This section describes special functions which can be activated by the “**PAL Extended User Mode**”.

The purpose of having two software access levels is to display discrete items and sections of the firmware at each level. Settings which need to be done rarely, perhaps at the time of installation of the System, are hidden at level 1 (User Level) and revealed at level 2 (Extended User Level). This also protects the System in group use. Nevertheless, the important points should be known by the user and are described below.

### How to Access “Extended User Mode”

Extended User Mode can be accessed by the following path:



**The above path as shown is an abbreviation for the following steps:**

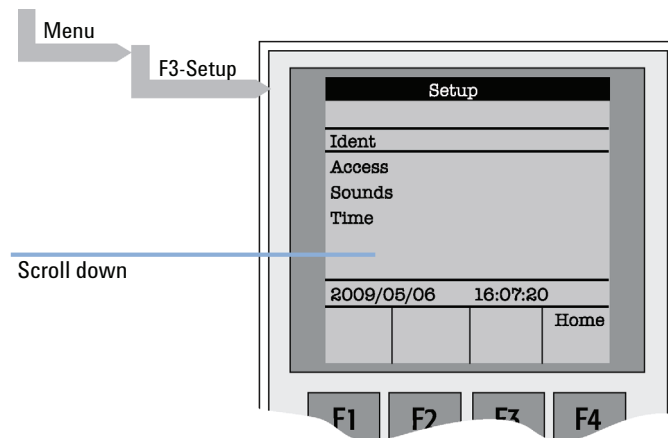
- 1 Menu/** scroll the cursor to **Setup/**
- 2 Press “F3” /**
- 3 Activate “Setup”** by pressing the center of the selector knob.

In this User Manual or in technical notes, only the following will be referred to:

**Menu > F3-Setup.**

## Section “F3-Setup”

The path to access this section is shown in [Figure 31](#) on page 80. This “**Setup**” section at the Extended User Level provides various options to access other classes which are not visible at the User Level. Some classes are known but may show some new items. Details are described in [Table](#) on page 81.



**Figure 31** Selecting “**Setup**” in Extended User Mode



Object	Description
Ident	The "Identification" of the system provides the opportunity to assign Users, site, and system names. The serial number of the System can be entered at this level. Remark: After loading a fresh Firmware Backup file, the SNo. is displayed as "XXXXXX".
Access	Access can be selectively opened or limited to different users for the " <b>Job</b> ", " <b>Method</b> " or " <b>Setup</b> ".
Sounds	The "Beep" sound can be adjusted to specific needs. For safety reasons it is advisable to keep the default settings, especially the " <b>Warn Move</b> ", turned ON to signal the start of the System to the user.
Time	The internal clock can be set. Remark: If the clock is fast, reset all items, from " <b>Year</b> " to " <b>Seconds</b> " and use the mandatory " <b>F1</b> " " <b>Set Time</b> ".
Communication <sup>1</sup>	The communication mode, serial or LAN, can be selected and conditions are defined.
System <sup>2</sup>	Basic parameters can be predefined for specific needs. Details see " <a href="#">System</a> " on page 82.
Service <sup>2</sup>	Basic service tests can be activated. Details see " <a href="#">Service</a> " on page 85.
Objects	Accessing the Firmware class " <b>Objects</b> " in the Extended User mode provides more detailed possibilities for object items. At this level an Object can be copied or deleted by using the specific function keys. This provides quick access to add e.g. a second or third injector.

<sup>1</sup> Available beginning with PAL Firmware Level 4.1.X.

<sup>2</sup> Explained in detail below.

## System

The following “**System**” Items can be changed by selecting the particular item.

Beginning with Firmware Level 4.1.X, an intermediate step was added. After selecting “**System**”, the new “**Settings**” level follows. Activating “**Settings**” opens up the described Items below.

Item	Description
<b>Syr Detect</b>	The syringe detection can be turned off in cases of sensor failure or if a special syringe with unknown ID is installed. Turning OFF the syringe identification sensor automatically displays a dialog box enabling the selection of syringe identification manually.
<b>Start Ref</b>	This item provides the choice of referencing all axes at the start of the system or suppressing the referencing. It is advisable to use this function actively to detect a possible loss of steps.
<b>Stop XY Error</b>	This function allows turning off the automatic recovery of the system after detection of a collision (loss of steps of a stepper motor). <b>Stop XY Error = ON:</b> Automated recovery turned OFF <b>Stop XY Error = OFF:</b> Automated recovery turned ON In Firmware level 2.3.X the new feature that recovers automatically after detecting a collision has been implemented. Firmware level 2.6.2 provides the possibility of disabling automated recovery. If recovery is turned OFF, the system always checks its position before moving to the injection port for injection. This can lead to an extra move, crossing over the X-,Y-axes sensors – if the injection port is at the opposite end of the X-axis relative to the sample location, (zero X-axis position in-between sample location and injection port). For critical application fields, e.g. clinical analyses, it is advisable to turn off the automated recovery; <b>Stop XY Error= ON.</b>
<b>PlgPathCheck<sup>1</sup></b>	The plunger travel path is monitored to ensure that the plunger tip reaches the syringe zero point in all cases – compared to original plunger referencing and defining the syringe zero point. If an error is detected, the System stops operation. This feature is useful if sample solutions with particles need to be handled, or if the syringe type is not adequate for the solution composition, or if the syringe plunger is blocked or even bent, such an error will be recognized and the system will come to an emergency stop.
<b>PlgChnge Pos</b>	Changing a syringe using the Menu function “ <b>Chnge Syr</b> ” moves the plunger up to the position specified by this item. For normal use, accept the default values.

Item	Description
<b>Init Syr at</b>	<p>The syringe plunger can be initialized (referenced) at “<b>Home</b>” or “<b>Waste</b>” position.</p> <p>If samples with a high danger of toxicity are treated, it is advisable to use the “<b>Waste</b>” position for referencing.</p>
<b>Inj Signal</b>	<p>An Autosampler is usually the master in a total chromatographic system. The other components send a “<b>Ready</b>” signal to enable a start of the Autosampler. At the moment of injection a Start signal is sent from the System to the other component(-s) of the entire system. With this “<b>Inj Signal</b>” item the status at which the signal is sent out can be defined. The syringe is filled with the defined sample volume.</p> <p><b>PlgUp</b> = Start signal at the moment the plunger starts moving down for injection.</p> <p><b>PlgDown</b> = Start signal at the moment the plunger reached zero point from syringe (recommended for large volume injection, but not in combination with Agilent Chemstation).</p> <p><b>ValveSw</b> = Start signal sent at the moment the injection valve is switched, HPLC technique.</p> <p><b>PreInj</b> = Start signal sent at a time before injection, as with a sample preparation device started before a GC or LC system. Minus time relative to chromatographic start time.</p>
<b>Vial PrePress</b>	<p>This item can be activated to avoid a vacuum if a relatively large amount of sample is taken out of a small volume vial. If e.g. a volume of 50 µL is specified for injection, the PAL system first takes 50 µL ambient air and “injects” this volume into the sealed vial, causing overpressure in the vial. After this step, the sample volume can be aspirated without forming a vacuum.</p> <p>This functionality is only valid for liquid sampling, not for the Headspace technique.</p> <p>Starting with Firmware level 4.1.X, this item is also active in combination with Cycle Composer.</p>
<b>LC-Inj</b>	Standard cycle for HPLC technique.
<b>LC-Cut</b>	Cycle for column switching with two valves, HPLC technique.
<b>GC-Inj</b>	<p>Standard Cycle for GC technique.</p> <p>Details on method parameters see “<a href="#">Injection Cycles</a>” on page 114 and “<a href="#">Software Flow Chart</a>” on page 128.</p>
<b>GC-InS</b>	<p>Standard cycle covering GC Sandwich technique.</p> <p>Details on method parameters see “<a href="#">Injection Cycles</a>” on page 114 and “<a href="#">Software Flow Chart</a>” on page 128.</p>

### 3 Agilent GC Injector 80 Description and Installation

#### Special Functions

Item	Description
<b>GC-Dual</b>	Cycle for GC technique which allows injecting two samples in two different injectors. The start signal is sent after injection of both sample solutions. Details on method parameters see “Injection Cycles” on page 114 and “Software Flow Chart” on page 128.
<b>HS-Inj</b>	Standard cycle for GC headspace technique.
<b>SPME</b>	Standard cycle for GC SPME technique, Solid Phase Micro Extraction, Fiber technique. Details on method parameters see “Software Flow Chart” on page 128.
<b>TTS Sotax</b>	The two cycles are dedicated cycles for “dissolution applications”. TTS cycle is used for transdermal patches and the Sotax cycle is used for tablet dissolution.

<sup>1</sup> Available beginning with Firmware Level 4.1.X.

#### NOTE

Standard injection cycles are selectable and activated directly from the System. Any deviation from a standard cycle, a Cycle Composer Macro, or Cycle Editor (ICC-CE) Cycle must be programmed for customized requirements.

## Service

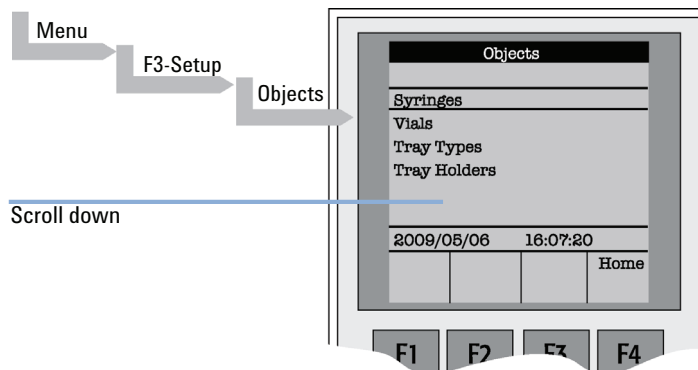
“**Service**” items may be changed by selecting the particular item (see [Table](#) on page 85).

Item	Description
<b>Check Motors</b>	Every stepper motor can be moved separately. This function is useful to check out a specific motor or to perform an endurance test after a repair. The Start and Stop positions of the test path can be selected. The motor Current, Speed, and Acceleration are selectable (accept default value to be sure). A Pause time can be specified. A Cycle Limit and Actual Cycle Counter are useful tools for endurance tests.
<b>Test Head</b>	This tests the functionality of the Injection Unit (“ <b>Head</b> ”). Two tests can be activated by the function keys: <b>“F1” Check Plg:</b> The stepper motor of the plunger drive is tested. Sensor check. <b>“F2” Check Z:</b> The vial detection sensor and “ <b>Needle Guide Blocking</b> ” function is tested. These tests are only required if any erratic behavior of the System is observed. In such cases contact a representative of Agilent Technologies.
<b>Test Switches</b>	<b>X-Limit</b> = Actual status of X-axis sensor. Move the X-Y-Carriage manually across the limit switch to verify activation of the sensor. <b>Y-Limit</b> = Actual status of X-axis sensor. Move the Y-axis manually to the Y-zero point (at X-axis), crossing over the limit switch to verify activation of the sensor. <b>Z-Limit</b> = Actual status of Z-axis sensor. Move the syringe slider assembly manually up to the zero Z-axis point, crossing over the limit switch to verify activation of the sensor. <b>Aux1 Limit</b> = Actual status of Aux1 limit sensor <b>Aux2 Limit</b> = Actual status of Aux2 limit sensor <b>Plg –Pos</b> = Actual status of Plg –Pos <b>Needle Guide</b> = Actual status of needle guide sensor

## Section “F3-Setup” / Objects

The same as is described above applies for the section “**Objects**” opened in Extended User Mode. New classes are visualized and known classes may contain new items accessible only on the level of the Extended User Mode.

To open this level, use the following path:



**Figure 32** Selecting “Objects” in Extended User Mode

Object	Description
<b>Syringes</b>	At this level all loaded syringes are selectable. At the <b>Utilities</b> user level only the active syringe is visible.
<b>Vials</b>	The Firmware Objects accessed on the Extended User Mode have more specific items selectable than at the User level. Tolerances or ranges such as, e.g. <b>Maximum Penetration</b> can be defined and limited for the user such that this value cannot be exceeded. In the Object <b>Tray Types</b> , details for the various Items are described more closely.
<b>Tray Types</b>	The object class <b>Tray Type</b> is only accessible via the Extended User Level. All loaded Tray Types are visible and selectable. Details, see " <a href="#">Tray Type</a> " on page 90.
<b>Tray Holders</b>	The Firmware Objects accessed on the Extended User Level have more specific items selectable than at the User level. Depending on the type of Tray Holder, e.g. an Access and Restore Path or a Heater and Agitator (motor) is assigned. Typical example, the Tray Holder <b>Agitator</b> .
<b>Trays</b>	All loaded Trays are visible and accessible. A Tray must be assigned to a Tray Holder. A <b>TrayTypeGroup</b> identification checks if the specified Tray Type is allowed in this combination. The offsets X-,Y-, Z and the inclination corrections for a row or column are explained in the <b>Utilities Functions</b> section. The <b>Path Offset X-,Y-, Z</b> is used only if a <b>Path</b> is assigned to the specified Tray Holder, typically a Stack or Agitator uses a Path.
<b>Wash Stations</b>	The Wash Station and its positions <b>Wash1</b> and <b>Wash2</b> are visible and selectable. Details , see " <a href="#">Wash Stations</a> " on page 97.
<b>Injectors</b>	The Firmware Objects accessed on the Extended User Mode have more specific items selectable than at the User Level. Tolerances or ranges such as <b>Maximum Penetration</b> can be defined and limited for the user so that this value cannot be exceeded. In the <b>Tray Types</b> Object, details for the various Items are described. Furthermore, in this Firmware Object class a <b>Valve</b> and/or a <b>Heater</b> can be assigned. Note that the Wash Station Positions <b>Waste</b> and <b>Waste2</b> are listed in this <b>Injectors</b> class.
<b>Valves</b>	The Valves and Valve Drives connected and controlled by an <b>AUX</b> interface are listed in this Object class. For more details, see the Valves and Valve Drives Addendum. Note that the valves controlled by serial communication (Serial Valves or Multiposition Valves) are in the Firmware Object class <b>Serial Valves</b> .

### 3 Agilent GC Injector 80 Description and Installation

#### Special Functions

Object	Description
<b>Agitators</b>	At this level items such as <b>Motor Drive</b> , <b>Minimum Speed</b> and <b>Maximum Speed</b> are selectable for the <b>Agitator</b> Object. The range can be set for the speed. The other items are available directly as Method parameters.
<b>Dilutors</b>	The Firmware Objects accessed in the Extended User Mode have more specific items selectable than at the User level. Tolerances or ranges such as <b>Maximum Fill Speed</b> can be defined and limited for the user so that this value cannot be exceeded. Items such as <b>Prime Volume</b> , <b>Waste to</b> , <b>Motor Drives</b> , or <b>Scale Length</b> are specific items that remain hidden at the User level.
<b>Tools</b>	The Object class <b>Tools</b> is used to handle another device, such as the MHE-Tool (Multiple Headspace Extraction Tool) or MALDI Tool. For details, see the specific Addendum for the User Manual.
<b>Positions</b>	The various positions used with the System are selectable at this level. Positions such as <b>Home</b> , <b>Change Syringe</b> , or a Path Point, reference the Paths for a specified Tray Holder directly, such as <b>Agitator</b> or <b>Stack</b> . Selecting an item, e.g. <b>Home</b> will provide <b>F1</b> , <b>Check Pos</b> on the screen. Activating this function provides the possibility of verifying X-, Y-, Z-axes values for this particular position.
<b>Paths</b>	A Path defines specific movements for the Injection Unit, which represent a repetitive task assigned to a Tray Holder. Typical examples are opening and closing a drawer from a Stack or opening the lid of an Agitator. The Path is composed of several steps (points) which are added up in a sequence. Each individual step (point) can be positioned by teaching X-, Y-, Z-axes. In most cases the return path is in the reverse order of the starting path. Example <b>AgiOpnL</b> and <b>AgiClsL</b> . If one setting of a point is changed, this change will be valid for the return path as well.
<b>Sync Signals</b>	The various synchronization signals are described in “ <a href="#">Synchronization and Output Signals</a> ” on page 75. At this level no other functionality, as shown at the user level, is provided.
<b>Out Signals</b>	The various Out-Signals are described in “ <a href="#">Synchronization and Output Signals</a> ” on page 75. At this level no other functionality, as shown at the user level, is provided.



Object	Description
<b>Events</b>	<p>The various synchronization signals are described in “<a href="#">Synchronization and Output Signals</a>” on page 75. At this level no other functionality, as shown at the user level, is provided. Three events are newly available at this extended user level:</p> <p><b>Pwr-Out1</b>, <b>Pwr-Out2</b> and <b>FlushVlv</b>. The main purpose of these three power-out signals is to activate a solenoid, such as for the Wash Station or the Gas Flush Valve. At this level the functionality of the signal can be tested.</p>
<b>Out Exp Box</b>	<p>The Out Expansion Box provides 8 TTL contacts and 8 relay contacts (24 V contact closure). The optional module (box) is connected and controlled by Interface 2.</p>
<b>RS232</b>	<p>This Object allows selecting the serial ports for the specific needs. Choices are:</p> <p><b>Remote</b>, <b>Terminal</b>, <b>Printer</b>, <b>Barcode</b>, <b>ExtDev</b>, <b>VICI-Vlv</b> (for serial valve drives), or <b>None</b>.</p>
<b>Motors<sup>1</sup></b>	<p>In the class <b>Motors</b> the Object <b>Motor-Y</b> is accessible in order to select the items Strategy and Path Speed.</p> <p>Three different settings are selectable for the Y-Motor movement strategy:</p> <ul style="list-style-type: none"> <li>• <b>Rectang</b> = normal movement as used for system. (On firmware level &lt; 4.01.X. this mode was called <b>Auto</b>.) XY-Simul = X,-Y-axes move simultaneously, which allows movement in a diagonal direction. (At firmware level &lt; 4.1.X this mode was called <b>Rectang</b>, but it was not active at lower levels.)</li> <li>• <b>Retract</b> = Y-axis moves from any point first to zero Y (back to the X-axis) before the X-movement is started. This mode allows bypassing an object (such as a large GC detector) which may be in the travel path if the default mode <b>Rectang</b> is used.</li> <li>• <b>Path Speed</b> = Y-axis motor speed in conjunction with a <b>Path</b>, example: Opening and closing a drawer of a Stack. In certain situations it is necessary to slow down the speed to open and close a drawer. Typical application example is fraction collection, collecting directly into a well plate. If the liquid level is high, the liquid can wash over into the next row if drawer movement is too fast.</li> </ul>

**NOTE**

At Firmware level 4.1.X these items of the Y motor have been made available at the Extended User Level.

<sup>1</sup> Available beginning at PAL Firmware Level 4.1.X

### Tray Type

The following object “**Tray Type**” Items may be changed by selecting the particular item. First select the desired Tray Type, such as “**VT32-20**”.

#### NOTE

The definition of Row and Column is given in “[Definition of a Tray Row and Column](#)” on page 64.

By reversing the first six entries, the order of injection can be changed.

Example: Tray Type “**VT32-20**” has a “**Row Length Y**” and a “**Col Length X**” defined. Reversing to “**Row Length X**” and “**Col Length Y**” would start with sampling from left to right, as used e.g. with Tray Type “**DW96**”.

The values of the items “**Spl Per Row**” and “**Spl Per Col**” must also be reversed.

---

Item	Description
<b>Row Length X</b>	Defines the Row length in the X-direction from the center of the first to the center of the last vial position, measured in mm.
<b>Row Length Y</b>	Defines the Row length in the Y-direction from the center of the first to the center of the last vial position, measured in mm.
<b>Col Length X</b>	Defines the Column length in the X-direction from the center of the first to the center of the last vial position, measured in mm.
<b>Col Length Y</b>	Defines the Column length in the Y-direction from the center of the first to the center of the last vial position, measured in mm.
<b>Spl Per Row</b>	Number of samples per Row.
<b>Spl Per Col</b>	Number of samples per Column
<b>Pattern<sup>1</sup></b>	<p>The pattern of the Row or Column arrangement has to be defined.</p> <ul style="list-style-type: none"> <li>• <b>Regular</b> = square arrangement (standard)</li> <li>• <b>Staggrd+</b> = Rows are arranged in staggered pattern. <ul style="list-style-type: none"> <li>• Offset of second Row is shifted by +50 %5 of hole pattern.</li> </ul> </li> <li>• <b>Staggrd-</b> = Rows are arranged in staggered pattern. <ul style="list-style-type: none"> <li>• Offset of second Row is shifted by -50 % of hole pattern.</li> </ul> </li> </ul> <p>See Graphics below.</p>
<b>TrayTypeGroup</b>	Software protection so that not every Tray Type can be placed on any Tray Holder. Example: VT32-20 cannot be fit into a Stack.
<b>Plate Thickn</b>	Thickness of Tray plate bottom (not the total height of the Tray). Measured in mm.
<b>Vial Height</b>	Total height of the vial including cap to seal if applicable. Measured in mm.
<div style="background-color: #cccccc; padding: 5px; display: inline-block;"><b>NOTE</b></div> <p>The sum of the plate thickness and vial height adds up to the total height This is the point where the Injection Unit expects an object.</p>	
<b>Vial Trnsprt<sup>2</sup></b>	<p>The mode to transport a vial is defined by:</p> <ul style="list-style-type: none"> <li>• <b>None</b> = No transport required. Example liquid sampling.</li> <li>• <b>Magnet</b> = Magnetic Transport. Requires magnetic vial caps. The Injection Unit moves to the side to slide the vial off when moved away.</li> <li>• <b>Needle</b> = Device is transported with the syringe needle inserted. Example: special vials where a magnetic cap cannot be crimped, e.g. <b>Vacutainer</b>.</li> </ul>

### 3 Agilent GC Injector 80 Description and Installation

#### Special Functions

Item	Description
<b>ZSlideOffRetr<sup>1</sup></b>	If magnetic transport is selected, the distance can be defined to move the syringe slider up (Z-direction), lifting up the vial by magnetic force. Measured in mm.
<b>YSlideOffDist<sup>1</sup></b>	If magnetic transport is selected, the distance can be defined to move the Injection Unit to the side, Y-direction, to slide the vial off. Measured in mm.
<b>Barcode</b>	If a Barcode Reader is installed, the mode has to be set for <b>AutoFix</b> . <b>None</b> = No Barcode Reader option requested for this Tray Type.
<b>Z Tolerance</b>	A tolerance window to give a plus/minus range (expressed in mm) where the Injection Unit must expect an object. If the value of this item is > 0, this is a relative detection mode and the sensor from the Injection Unit needle guide is active. If the value of this item is set to 0 the sensor of the needle guide is turned off and the syringe slider moves to an absolute value, Z-axis position as specified in the object.
<b>Z Retract</b>	The distance to lift up the syringe slider before the Y-, Z-axes assembly moves across the unit can be specified, expressed in mm.
<b>Max Penetr</b>	The maximum allowed Needle Penetration can be defined as a safety so that the user cannot destroy the needle tip by going too far down. The Tray Type is prepared for a specific vial size; this value is therefore unique to this combination. The maximum needle penetration must not exceed the length of the syringe needle, considering the loss due to needle guide, etc.. Typical needle length is 51 mm, maximum penetration must not exceed 48 mm.
<b>Needle Penetr</b>	This item is identical to that used on the User Level or, if available, as a method parameter of a local cycle. The value defined on these levels is mirrored to the Extended User level.
<b>Spl1 Offset X</b>	The X offset is defined as the distance from the outer edge of the Tray in the X-direction to the center of the vial position 1. Measured in mm.
<b>Spl1 Offset Y</b>	The Y offset is defined as the distance from the outer edge of the Tray in Y-direction to the center of the vial position 1. Measured in mm.
<b>Spl1 Offset Z</b>	The Z offset can be selected for special cases where, e.g. the syringe needle has to reach a deeper point before penetration into a vial. A Z offset value = 0 considers the Tray surface or vial top as the reference point. Measured in mm.

<sup>1</sup> Available beginning with Firmware Level 4.1.X

<sup>2</sup> Available beginning with Firmware Level 2.5.X

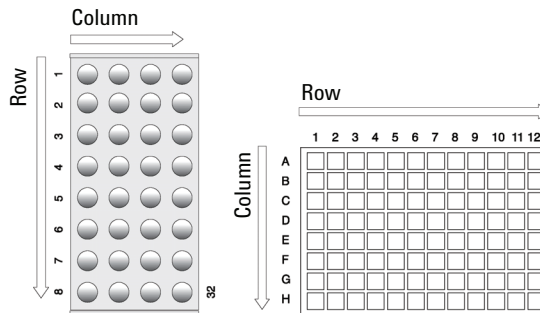
**NOTE**

The dimensions used for Row/Column Length or X-, Y-, Z-Offsets for Sample Number 1, are specific for a particular Tray Type. If a general adjustment for a Tray from a specific vendor – e.g. for a Deepwell Plate – has to be made, this should be done in the “**Tray Type**” class of Object. For fine tuning, the Offset items from the class “**Trays**” can be used.

Explanation for various Patterns in Tray Type:

**1 Pattern Type “Regular”.**

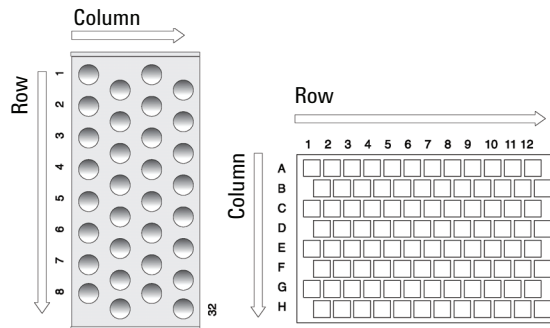
The sample or well positions are equal distributed.



**Figure 33** Pattern Tray Type “Regular”

**2 Pattern Type “Staggerd+”.**

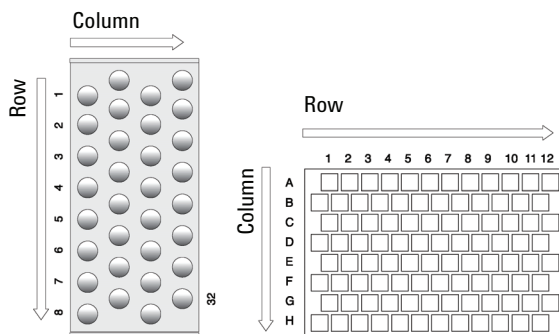
The sample or well positions are arranged in a staggered pattern. Offset of second Row is shifted by +50 % of hole pattern.



**Figure 34** Pattern Tray Type “Staggered+”

**3 Pattern Type “Staggrd-”.**

The sample or well positions are arranged in a staggered pattern. Offset of second Row is shifted by -50 % of hole pattern.



**Figure 35** Pattern Tray Type “Staggered-”

## Trays

The following object “**Tray**” Items can be changed by selecting the particular item. First select the desired Tray, such as “**Tray1**”.

Item	Description
<b>Tray Holder</b>	The Tray Holder to which the Tray is assigned is specified.
<b>TrayTypeGroup</b>	All Tray Type Groups which are allowed for this particular combination of Tray and Tray Holder are displayed. The “ <b>TrayTypeGroup</b> ” for the Tray Type itself is specified for each Tray Type.
<b>Tray Type</b>	The Tray Type to be used is linked to the Tray. This item is usually set at User Level in “ <b>Utilities &gt; Trays</b> ”. See above.
<b>Offset X</b>	The “X” offset is defined as the distance from the center of the teaching position from the Tray Holder to the edge of the Tray in X-direction. Measured in mm. This item is available at User Level in section “ <b>Utilities &gt; Tray</b> ” and can be used for fine tuning a Tray installed in a Tray Holder. Important for well-plates 384 installed in a Stack.
<div style="background-color: #cccccc; padding: 5px; display: inline-block;"><b>NOTE</b></div> Position#1 is the only correction point.	
<b>Offset Y</b>	The “Y” offset is defined as the distance from the center of the teaching position from the Tray Holder to the edge of the Tray in Y-direction. Measured in mm. This item is available at User Level in section “ <b>Utilities/Tray</b> ” and can be used for fine tuning a Tray installed in a Tray Holder. Important for well-plates 384 installed in a Stack.
<div style="background-color: #cccccc; padding: 5px; display: inline-block;"><b>NOTE</b></div> Position#1 is the only correction point.	

### 3 Agilent GC Injector 80 Description and Installation

#### Special Functions

Item	Description
<b>Offset Z</b>	<p>The "Z" offset is defined as the distance from the plate surface of the Tray Holder to the teaching point, black needle guide flush underneath plate of Tray Holder (which corresponds to plate thickness of Tray Holder). Measured in mm.</p> <p>This item is available at User Level in section "Utilities/Tray" and can be used for fine tuning a Tray installed in a Tray Holder. Important for well-plates 384 installed in a Stack.</p> <p><b>NOTE</b> Position#1 is the only correction point.</p>
<b>Path Offset X</b>	<p>The Path Offset "X" can be specific for a Tray, adjustment in X-direction. Expressed in mm.</p> <p><b>NOTE</b> This item is only valid if a Path is assigned to the Tray Holder as specified in this combination.</p>
<b>Path Offset Y</b>	<p>The Path Offset "Y" can be specific for a Tray, adjustment in Y-direction. Expressed in mm.</p> <p><b>NOTE</b> This item is only valid if a Path is assigned to the Tray Holder as specified in this combination.</p>
<b>Path Offset Z</b>	<p>The Path Offset "Z" can be specific for a Tray, adjustment in Z-direction. Expressed in mm.</p> <p><b>NOTE</b> This item is only valid if a Path is assigned to the Tray Holder as specified in this combination.</p>



## Wash Stations

The following object “**Wash Station**” items may be changed by selecting the particular item. First select the desired Wash Station, such as “**Wash1**”.

Item	Description
<b>Position X</b>	X-axis position for Wash Station.
<b>Position Y</b>	Y-axis position for Wash Station.
<b>Position Z</b>	Z-axis position for Wash Station.
<b>Z Tolerance</b>	<p>A tolerance window for a plus/minus range (expressed in mm) where the Injection Unit has to expect an object.</p> <ul style="list-style-type: none"> <li>• If the value of this item is <math>&gt; 0</math>, this is a relative detection mode and the sensor from the Injection Unit needle guide is active.</li> <li>• If the value of this item is set to “0” the sensor of the needle guide is turned off and the syringe slider moves to an absolute value, Z-axis position as specified in the object.</li> </ul>
<b>Z Retract</b>	The distance to lift up the syringe slider before the Y, Z-axes assembly moves across the unit can be specified, expressed in mm.
<b>Max Penetrat</b>	<p>The maximum allowed Needle Penetration can be defined as a safety so that the user cannot destroy the needle tip by going too far down. The maximum needle penetration must not exceed the length of the syringe needle, considering the loss due to needle guide, etc..</p> <p>Typical needle length is 51 mm, maximum penetration must not exceed 48 mm.</p>
<b>Needle Penetr</b>	This item is identical to that at the User Level. The value defined at this level is mirrored to the Extended User level.
<b>Type</b>	<p>The specific mode for the Wash Station in use has to be defined:</p> <ul style="list-style-type: none"> <li>• <b>Standard</b> = Standard Wash Station. Syringe is filled with wash solvent and expelled into Waste.</li> <li>• <b>Pulse</b> = A pulsed signal is sent to activate the device. Used for the “<b>Fast Wash Station</b>” and “<b>Active Wash Station</b>”.</li> <li>• <b>Flow</b> = Continuous flow of liquid by gravity. No electrical contact required for a solenoid.</li> <li>• <b>DLW</b> = Dynamic Load &amp; Wash. Item used to activate specific solenoid for DLW Wash Station. (Available beginning with Firmware Level 4.0.X)</li> </ul>
<b>Flow Control</b>	The power source to activate a Wash Station is specified. For the Fast, Active Wash Station and DLW the Event “ <b>Power-Out1</b> ” and “ <b>Power-Out2</b> ” are used.

### 3 Agilent GC Injector 80 Description and Installation

#### Special Functions

Item	Description
<b>Ndl Cln Path</b>	A Path can be assigned to the Wash Station.
<b>Waste to</b>	The Waste position is assigned to the Wash Station.
<b>Clean Volume</b>	A percentage of the syringe maximum volume is defined for the cleaning step.
<b>Clean Count</b>	The counter monitors the number of wash cycles. The setting in the method has the same functionality and the value is mirrored to the Extended User Level.
<b>Max Fill Spd</b>	The fill speed for the syringe is defined with this item. If the maximum value of the Fill Speed (10.0 ml/s) is selected, the system takes the injection syringe Fill Speed as defined in the method.
<b>Max Eject Spd</b>	The Eject Speed is the speed used to eject the wash solvent during the wash cycle. This speed is usually higher than the Fill Speed. If the maximum value of the Eject Speed (10.0 ml/s) is selected, the system takes the injection syringe Eject Speed as defined in the object class "Syringe".
<b>Rinse Time</b>	Rinse is the time to rinse the wash port with wash solvent after the wash cycle of the syringe has been finished. In the case of a Fast/Active Wash Station, the syringe needle is pulled out of the wash port. The wash solvent flows without restriction. As a result, higher solvent consumption has to be taken into consideration.

## Troubleshooting

### NOTE

The autosampler represents always one of several components in a chromatography system.

The following Troubleshooting Guide is limited to the autosampler.

---

### No or very low detector signal is observed.

#### Probable cause

- 1 Clogged syringe.
- 2 Bent needle.
- 3 No sample liquid is injected.
- 4 Sample volume too low.

#### Suggested actions

- Remove syringe and aspirate/dispense liquid manually. Clean syringe.
- Inspect and/or change syringe.
- Check and/or adjust Needle penetration into sample vial (see ["Utility Functions"](#) on page 24).
- Increase sample volume.

## Syringe does not fill properly.

### Probable cause

- 1 Air bubbles below Syringe plunger. Air bubbles may remain below the plunger after the first pull up. If the plunger is moved up and down several times, these air bubbles are worked out.

### Suggested actions

Increase method parameter "**Fill Strokes**".

## Sample peaks/responses are not reproducible.

### Probable cause

- 1 Dirty syringe.
- 2 Syringe pressure differences.
- 3 Vacuum created in sample vial.
- 4 Highly volatile solvent.
- 5 Not properly crimped vials.
- 6 Method Parameters

### Suggested actions

- Increase Pst Cln Slv1/Slv2 values in method.
- Use PreClnSlv1/Slv2 and PreClnSpl.

Increase Pullup Delay value.

Reduce sample volume in sample vial. Use setting under **F3-Setup > System > PrePressureVial**.

Use gastight syringe and sample tray cooling.

Check vial cap by attempting to rotate by hand. Loose caps may cause selective loss of lighter components from sample. Adjust crimping tool correctly.

Check recommended Method Parameters in "[Software Flow Chart](#)" on page 128. The following parameters are crucial and should be verified first: **Fill speed, Pullup delay, Injection Speed, Post Inj Delay**

## Excessive carryover between samples

### Probable cause

- 1 Dirty syringe.
- 2 Inappropriate wash solvent(s).
- 3 Wash Solvent and Waste vial septa too tight.

### Suggested actions

- Increase **Pst Inj Slv1/Slv2** values in method. Use **PreClnSlv1/Slv2** and **PreClnSpl**.
  - Check and, if necessary, replace vial septa from Wash/Waste vials.
- Use appropriate wash solvent(s).
- Check if the syringe fills completely when washing. If several cleaning cycles are programmed and many samples are processed, then vacuum in the Wash Solvent vials and overpressure in the Waste vials may build up. Cut away a segment of the Solvent and Waste septa to assure equalization of pressure.

## Unexplained collisions of the Injection Unit.

### Probable cause

- 1 Object(s) not defined correctly.

### Suggested actions

Define Object(s) correctly. (See [“Defining Object Reference Positions”](#) on page 59).

## **“Object Not Detected” (Object e.g. Tray1, LCVlv1, Stk1- 01)**

**Probable cause**

- 1 Incorrect Z value for the affected Object (e.g. GC Inj1, THldr1 or Agitator).

**Suggested actions**

Redefine Z value for the affected Object. (See [“Defining Object Reference Positions”](#) on page 59).

## **Invalid Motor Status Motor Aux.**

**Probable cause**

- 1 Control Board defective.

**Suggested actions**

Replace Control-GC Board.

## Replacing Parts

### Warnings and Cautions

#### WARNING

##### High voltage

**Capacitors inside the instrument may still remain charged even if the instrument is turned off.**

- Always disconnect the power cord(s) from the power supply or from the various power supplies if optional devices are installed before attempting any type of maintenance.
  - To avoid damaging electrical parts, do not disconnect an electrical assembly while power is applied to the PAL system. Once the power is turned Off, wait approximately 30 seconds before you disconnect an assembly.
-

## Control Board

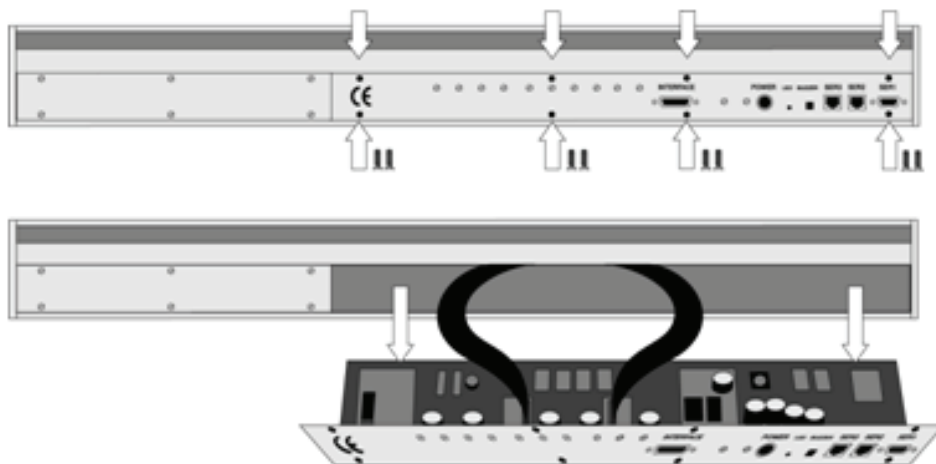
### Control GC Board

**Parts required**      **G6500-81003    PCB, CPU and MOTIO Board for GC Sampler 80**  
APR Control-GC   APR Control-GC

- 1 Follow the sequence shown in [Figure 36](#) on page 104 to detach and release the Control-GC board from its position inside the X-axis. As shown, remove the dummy cover first.
- 2 Carefully pull the two ribbon cable connectors upwards to free them from the board.
- 3 Install the replacement board in the reverse order.

#### NOTE

After reconnecting the two ribbon cables to the board, ensure that the cables are folded flat and can slide inside the X-axis without damage.



**Figure 36** Replacing Control-GC Board



## Control-xt Board

<b>Parts required</b>	<b>G6500-64220 PCB, xt Main Board</b>
1	APR Control
1	Agilent Control Software

### NOTE

The Control-xt board combines the MOTIO and the CPU boards in a single control board. This board operates only at Firmware level 4.1.X.

---

- 1** Follow the sequence shown in to detach and release the Control-xt board from its position inside the X-axis. As shown, remove the dummy cover first.
- 2** Carefully pull the two ribbon cable connectors upwards to free them from the board.
- 3** Install the replacement board in the reverse order.

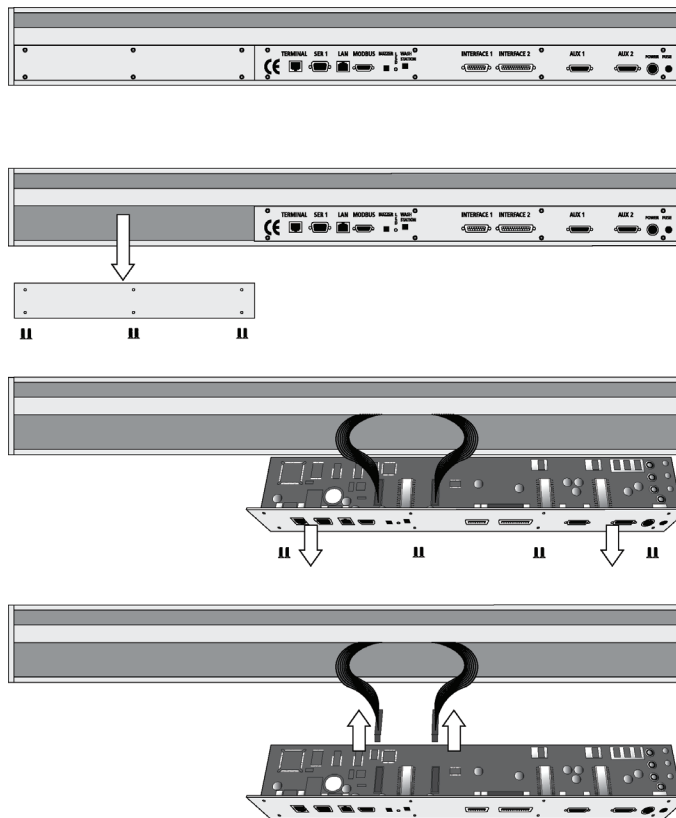
### NOTE

After reconnecting the two ribbon cables to the board, ensure that the cables are folded flat and can slide inside the X-axis without damage.

---

### 3 Agilent GC Injector 80 Description and Installation

#### Replacing Parts



**Figure 37** Replacing Control-xt Board

## Injection Unit

Follow the sequence of steps shown in “Assembling the Agilent GC Injector 80” on page 50.

## Maintaining the Autosampler System

Regularly performing maintenance helps ensure accuracy and precision of the autosampler system. Suggested intervals for maintenance procedures are given below to ensure uninterrupted operation. If you use the system extensively (for example, nights and weekends), or if you use corrosive solvents, you may need to perform the maintenance procedure more frequently.

Maintenance Step	Interval
Clean the outside of the instrument. Use only a soft lint-free cloth dampened with mild soap and water.	Weekly or as needed.
Clean Instrument, syringe and surfaces	Weekly or as needed.
Replace the syringe plunger	Syringe Plunger for a liquid syringe (Metal Plunger sealing against glass) should be cleaned on a regular basis with an aqueous alcohol solution. Be aware that this plunger type should not be used for samples with a high amount of matrices, for clinical or residue analysis. A polymer plunger tip would be more suitable. Syringe Plunger for a gas tight syringe (polymer tip) has to be replaced on a regular basis. The interval is highly dependent on the application, throughput, quality of sample solution (particles, etc.) washing solvent. It is advisable to check the tightness of the plunger on a regular basis to gain experience with the application.
Wash and Waste Solvent reservoirs	Weekly or as needed. Replace the Septum as well to avoid carry-over.

The other steps are described in the “Preventative Maintenance Procedure”.

Specific kits are available. Maintenance Kit for GC/LC System (p/n G6500-88088) includes the parts which must be changed annually.

### 3 Agilent GC Injector 80 Description and Installation

#### Maintaining the Autosampler System

**NOTE**

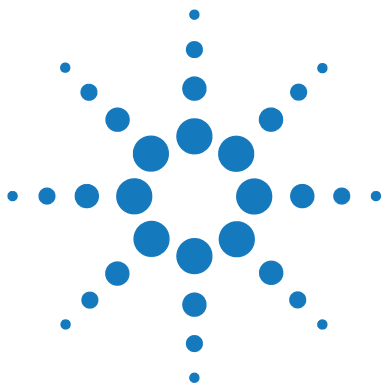
Contact your Agilent Technologies representative to perform an annual preventative maintenance on the autosampler system.

---

**NOTE**

There are no operator-serviceable or replaceable parts inside the power supply(ies) or the autosampler system. In case of any failure, contact a representative of Agilent Technologies.

---



## 4 Appendices

Definition of Terms	110
Conventions of Naming	113
Injection Cycles	114
"GC-Inj" Cycles	114
"GC-InjS" Cycle	118
"GC-Dual" Cycle	122
Software Flow Chart	128
Flow Chart based on Firmware Level 2.5.X.	128
External Connectors	132
Connector SER1	132
Connector TERMINAL or SER3	133
Connector INTERFACE 1*	134
Connector AUX1 *	135
Connector Power	136
Accessories	137

This chapter provides addition information on definition of terms, naming convention, injection cycle, firmware, external connectors and accessories.



## Definition of Terms

### Job Queue

A Job Queue is a list of sample processing Jobs. Jobs are executed in the order displayed on the JOB QUEUE menu screens. New Jobs may be added to the queue while samples are being processed.

### Job

A Job contains the information needed by the GC Injector 80 to process multiple samples by the same processing steps. The elements of a Job are a Method and a Tray that define the location of the samples to be processed. For identification, Jobs are automatically numbered from 01 to 99 and then restarting with 01 when they are added to the Job Queue.

### Cycle

A Cycle consists of the specific operations necessary to process one sample. The Cycle operations are repeated for each sample within a Job. Cycles are designed for specific applications.

### Method

A Method defines how the samples are processed. The elements of a Method are a Cycle, a Syringe and a Parameter List. Methods have names with up to eight characters and can be edited, copied, and deleted.

### Method Parameters

Method Parameters are associated with the Cycle operations. User-assigned Parameter values define how a processing operation is performed. A zero Parameter value will disable a Cycle operation. Cycle Parameters are application-specific.

### Tray Holder

A Tray Holder can hold one or more trays. Each Tray Holder has a reference position (X-, Y-, Z-coordinates) that defines its location.

## Tray

A Tray holds multiple samples. Trays are defined by designating the Tray Type (see below) and the Tray Holder. Tray names are used to identify the sample source within a Job.

## Tray Type

A Tray Type defines the pattern and sampling sequence of sample locations within a Tray.

## Stack

A Stack is a particular type of Tray Holder that is designed to hold micro-plates. A six-drawer Stack holds 12 standard microplates, two in each drawer.

A three-drawer Stack holds six deep-well micro-plates, two in each drawer.

## Object Manager

Software to load an Object List to an instrument if a Module (hardware module) has been added to the System. In a special mode Object Manager can also be used to create and maintain Object Lists.

## Object List

If a Module (hardware) is added to an instrument, several Objects have to be loaded into the firmware. These Objects are collected in an Object List and stored in a file with the extension “\*.pol”.

Object Lists are delivered together with Object Manager Software and are grouped into folders for the different kind of Modules (e.g. Syringes, Tray Holders, Valve Drives). The name of an Object List starts with the Module part number with variants added (e.g. first or second Stack). The name of the root folder includes the revision which is dependent on the firmware version (e.g. “**Object Lists Rev. K**“ for firmware 2.X and 3.X).

## Object Class

Each Object belongs to an Object Class (e.g. Syringes, Trays, Injectors).

The Object Class defines the Items of an Object.

### **Object Item**

An Object contains several Items which can be numerical values with a physical unit (e.g. X-, Y-, Z-Position, Penetration, Syringe Scale Length, Syringe Volume) or references to other objects.

**NOTE**

The term “Parameter” is reserved for “ATOM Parameter” (Firmware commands to be used for a Cycle).

---

### **Objects**

Objects are data structures describing the properties of physical modules. Certain modules (e.g. a Stack) require several objects.

### **Module**

Hardware module, either part of a standard system configuration (e.g. Agilent LC Injectors HTC/HTS, Agilent GC Sampler 80/120) or an optional addition (e.g. SPME Upgrade for Agilent GC Injector, MT/DW Tray, Stack, and Cooler Upgrades for Agilent LC Injectors HTC/HTS ). The term “Module” is intentionally used to differentiate from “Object”, which is reserved for the Firmware Object.



## Conventions of Naming

This section recommends standard naming convention for GC Injector 80 Trays, Tray Types, and Tray holders. Following these conventions will allow GC Injector 80 to be pre-configured for certain applications, will simplify software backups and application development, and will improve technical support and training.

**Table 26** Naming Convention

Tray Type	Tray Description
VT200	Vial Tray, 200 positions (10 x 20) For 7 mm micro-vials, 1 ml
VT98	Vial Trays, 98 positions (7 x 14) For 12 mm vials, 2 ml
VT78	Vial Tray, 78 positions (6 x 13) For 7 mm micro-vials, 1 ml (opposite side of 98 positions Tray)
VT54	Vial Tray, 54 positions (6 x 9) For 12 mm vials, 2 ml
VT21	Vial Tray, 21 Positions (7 x 14) For 12 mm vials, 2 ml (opposite side of 32 positions Tray)
VT32-10	Vial Tray, 32 positions (4 x 8) For 23 mm headspace vials, 10 ml
VT32-20	Vial Tray, 32 positions (4 x 8) For 23 mm headspace vials, 20 ml
MT96	Standard 96-position shallow microplate
DW96	Deep well 96-position microplate
MT384	High density 384-position shallow microplate

## Injection Cycles

### "GC-Inj" Cycles

**Table 27** "GC-Inj" Cycle

No.	Processing Step	Method Parameter	Object	(Class)	Used Object Value
1	Reference X, Y, Z axes and syringe plunger			(System)	<b>Start Ref = ON</b>
2	Wait for start signal		<b>Start</b>	(Sync Signals)	
3	Read Barcode if enabled		<b>TRAY</b>	(Tray Type)	<b>Barcode ? None</b>
4	Clean syringe with solvent from Wash1 selected number of times	<b>Pre Cln Slv1</b>	<b>SYRINGE</b>  <b>Wash1</b> <b>Waste</b>	(Syringes)  (Wash Stations) (Injectors)	<b>Fill Speed</b> <b>Eject Speed</b> <b>Needle</b> <b>Penetr</b> <b>Clean Volume</b> <b>Needle</b> <b>Penetr</b>
5	Clean syringe with solvent from Wash2 selected number of times	<b>Pre Cln Slv2</b>	<b>SYRINGE</b>  <b>Wash2</b> <b>Waste2</b>	(Syringes)  (Wash Stations) (Injectors)	<b>Fill Speed</b> <b>Eject Speed</b> <b>Needle</b> <b>Penetr</b> <b>Clean Volume</b> <b>Needle</b> <b>Penetr</b>
6	Rinse syringe with sample selected number of times	<b>Pre Cln Spl</b> <b>Sample</b> <b>Volume</b> <b>Fill Volume</b> <b>Fill Speed</b> <b>Pullup Delay</b>	<b>SYRINGE</b>  <b>TRAY</b> <b>Waste</b>	(Syringes)  (Tray Type) (Injectors)	<b>Eject Speed</b> <b>Needle</b> <b>Penetr</b> <b>Needle</b> <b>Penetr</b>

**Table 27** "GC-Inj" Cycle

No.	Processing Step	Method Parameter	Object	(Class)	Used Object Value
7	Fill syringe with sample using several filling strokes; aspirate air outside of vial if Air Volume = 0	<b>Sample Volume</b> <b>Air Volume</b> <b>Fill Volume</b> <b>Fill Speed</b> <b>Fill Strokes</b> <b>Pullup Del</b>	<b>SYRINGE</b>  <b>TRAY</b>	(Syringes)  (Tray Type)	<b>Eject Speed</b> <b>Overfill</b> <b>Needle Penetr</b>
8	Wait for Inject signal		<b>Inject</b>	(Sync Signals)	
9	Move to Injector	<b>Inject to</b>			
10	Drive needle to penetration depth	<b>Inject to</b>	<b>Motor Z</b>	(Injectors) (Motors)	<b>Needle Penetr</b> <b>Inj Penet Spd</b>
11	Delay	<b>Pre Inj Del</b>			
12	Activate Injected signal		<b>Injected</b>	(Out Signals)	<b>Pulse Time</b>
13	Activate Injectd+ signal		<b>Injectd+</b>	(Out Signals)	<b>Pulse Time</b>
14	Dispense syringe contents into GC Injector	<b>Inject Speed</b>			
15	Delay	<b>Pst Inj Del</b>			
16	Retract needle from injector		<b>Motor Z+</b>	(Motors)	<b>Inj Penet Spd</b>
17	Clean syringe with solvent from Wash1 selected number of times	<b>Pst Cln Slv1</b>	<b>SYRINGE</b> <b>Wash1</b> <b>Waste</b>	(Syringes) (Wash Stations) (Injectors)	<b>Fill Speed</b> <b>Eject Speed</b> <b>Needle Penetr</b> <b>Clean Volume</b> <b>Needle Penetr</b>

## 4 Appendices

### Injection Cycles

**Table 27** "GC-Inj" Cycle

<b>No.</b>	<b>Processing Step</b>	<b>Method Parameter</b>	<b>Object</b>	<b>(Class)</b>	<b>Used Object Value</b>
18	Clean syringe with solvent from Wash2 selected number of times	<b>Pst Cln Slv2</b>	<b>SYRINGE Wash2 Waste2</b>	(Syringes) (Wash Stations) (Injectors)	<b>Fill Speed Eject Speed Needle Penetr Clean Volume Needle Penetr</b>
19	Move to Home position		<b>Home</b>	(Positions)	

## "GC-Inj" Cycle Parameter Description

**Table 28** "GC-Inj" Cycle Method Parameter Description

<b>Parameter</b>	<b>Description</b>
<b>CYCLE</b>	GC-Inj
<b>SYRINGE</b>	Selected syringe
<b>Sample Volume</b>	Selected sample volume
<b>Air Volume</b>	Volume aspirated after the syringe needle is moved out of the sample liquid
<b>Pre Cln Slv1</b>	Pre injection syringe wash strokes with Solvent 1
<b>Pre Cln Slv2</b>	Pre injection syringe wash strokes with Solvent 2
<b>Pre Cln Spl</b>	Pre injection syringe wash strokes with Sample
<b>Fill Volume</b>	Fill Volume used for all filling strokes except the last one
<b>Fill Speed</b>	Speed of plunger movement used in all syringe filling operations
<b>Fill Strokes</b>	Number of fill Strokes
<b>Pullup Del</b>	Delay time between sample pullup and ejection
<b>Inject to</b>	Selected Injector
<b>Inject Speed</b>	Speed of plunger movement used during sample injection
<b>Pre Inj Del</b>	Delay time prior to sample injection
<b>Pst Inj Del</b>	Delay time after sample injection
<b>Pst Cln Slv1</b>	Post injection syringe wash strokes with Solvent 1
<b>Pst Cln Slv2</b>	Post injection syringe wash strokes with Solvent 2

## "GC-InjS" Cycle

**Table 29** "GC-InjS" Cycle

No.	Processing Step	Method Parameter	Object	(Class)	Used Object Value
1	Wait for Start signal		<b>Start</b>	(Sync Signals)	
2	Reference X, Y, Z axes and syringe plunger			(System)	<b>Start Ref = ON</b>
3	Read Barcode if enabled		<b>TRAY</b>	(Tray Type)	<b>Barcode ? None</b>
4	Clean syringe with solvent from Wash1 selected number of times	<b>Pre Cln Slv1</b>	<b>SYRINGE Wash1 Waste</b>	(Syringes) (Wash Stations) (Injectors)	<b>Fill Speed Eject Speed Needle Penetr Clean Volume Needle Penetr</b>
5	Clean syringe with solvent from Wash2 selected number of times	<b>Pre Cln Slv2</b>	<b>SYRINGE Wash2 Waste2</b>	(Syringes) (Wash Stations) (Injectors)	<b>Fill Speed Eject Speed Needle Penetr Clean Volume Needle Penetr</b>
6	Rinse syringe with sample selected number of times	<b>Pre Cln Spl Sample Volume Fill Volume Fill Speed Pullup Delay</b>	<b>SYRINGE TRAY Waste</b>	(Syringes) (Tray Type) (Injectors)	<b>Eject Speed Needle Penetr Needle Penetr</b>
7	Fill syringe with Solvent Plug from Slv Source; aspirate air outside of vial if Air Gap(s) <> 0	<b>Solvent Plug Slv Source Air Gap(s) Fill Speed Pullup Del</b>	<b>SYRINGE</b>	(Syringes) (Wash Stations, Vials)	<b>Fill Speed Overfill Needle Penetr</b>

**Table 29** "GC-InjS" Cycle

No.	Processing Step	Method Parameter	Object	(Class)	Used Object Value
8	Fill syringe with IntStd from Std Source; aspirate air outside of vial if air gap(s) <> 0	<b>IntStd</b> <b>Std Source</b> <b>Air Gap(s)</b> <b>Fill Speed</b> <b>Pullup Del</b>	<b>SYRINGE</b>	(Syringes) (Wash Stations, Vials)	<b>Fill Speed</b> <b>Overflow</b> <b>Needle Penetr</b>
9	Fill syringe with sample volume; aspirate air outside of vial if AirVolumeNdl <> 0	<b>Sample Volume</b> <b>AirVolumeNdl</b> <b>Fill Speed</b> <b>Pullup Del</b>	<b>SYRINGE</b> <b>TRAY</b>	(Syringes) (Tray Type)	<b>Fill Speed</b> <b>Overflow</b> <b>Needle Penetr</b>
10	Wait for Inject signal		<b>Inject</b>	(Sync Signals)	
11	Move to Injector	<b>Inject to</b>			
12	Drive needle to penetration depth	<b>Inject to</b>	<b>Motor Z+</b>	(Injectors) (Motors)	<b>Needle Penetr</b> <b>Inj Penet Spd</b>
13	Delay	<b>Pre Inj Del</b>			
14	Activate Injectd+ signal		<b>Injectd+</b>		<b>Pulse Time</b>
15	Dispense syringe contents into GC Injector	<b>Inject Speed</b>			
16	Delay	<b>Pst Inj Del</b>			
17	Retract needle from injector		<b>Motor Z+</b>	(Motors)	<b>Inj Penet Spd</b>
18	Clean syringe with solvent from Wash1 selected number of times	<b>Pst Cln Slv1</b>	<b>SYRINGE</b> <b>Wash1</b> <b>Waste</b>	(Syringes) (Wash Stations) (Injectors)	<b>Fill Speed</b> <b>Eject Speed</b> <b>Needle Penetr</b> <b>Clean Volume</b> <b>Needle Penetr</b>

## 4 Appendices

### Injection Cycles

**Table 29** "GC-InjS" Cycle

No.	Processing Step	Method Parameter	Object	(Class)	Used Object Value
19	Clean syringe with solvent from Wash2 selected number of times	<b>Pst Cln Slv2</b>	<b>SYRINGE Wash2 Waste2</b>	(Syringes) (Wash Stations) (Injectors)	<b>Fill Speed Eject Speed Needle Penetr Clean Volume Needle Penetr</b>
20	Move to Home position		<b>Home</b>	(Positions)	



## "GC-InjS" Cycle Parameter Description

**Table 30** "GC-InjS" Cycle Method Parameter Description

<b>Parameter</b>	<b>Description</b>
<b>CYCLE</b>	GC-InjS
<b>SYRINGE</b>	Selected syringe
<b>Sample Volume</b>	Selected sample volume
<b>Solvent Plug</b>	Volume aspirated to form sandwich with Solvent Plug
<b>Slv Source</b>	Source Vial for Solvent Plug
<b>IntStd</b>	Volume aspirated to form sandwich with Internal Standard or Reagent
<b>Std Source</b>	Source Vial for Internal Standard or Reagent
<b>Air Gap(s)</b>	Air Gap(-s) to separate Solvent Plug/IntStd/Reagent/Sample
<b>AirVolumeNdl</b>	Volume aspirated after syringe needle is moved out of the sample liquid
<b>Pre Cln Slv1</b>	Pre injection syringe wash strokes with Solvent 1
<b>Pre Cln Slv2</b>	Pre injection syringe wash strokes with Solvent 2
<b>Pre Cln Spl</b>	Pre injection syringe wash strokes with Sample
<b>Fill Speed</b>	Speed of plunger movement used in all syringe filling operations
<b>Pullup Del</b>	Delay time between sample pullup and ejection
<b>Inject to</b>	Selected Injector
<b>Inject Speed</b>	Speed of plunger movement used during sample injection
<b>Pre Inj Del</b>	Delay time prior to sample injection
<b>Pst Inj Del</b>	Delay time after sample injection
<b>Pst Cln Slv1</b>	Post injection syringe wash strokes with Solvent 1
<b>Pst Cln Slv2</b>	Post injection syringe wash strokes with Solvent 2

## "GC-Dual" Cycle

**Table 31** "GC-Dual" Cycle

No.	Processing Step	Method Parameter	Object	(Class)	Used Object Value
1	Reference X, Y, Z axes and syringe plunger			(System)	<b>Start Ref = ON</b>
2	Wait for Start signal		<b>Start</b>	(Sync Signals)	
3	Read Barcode if enabled		<b>TRAY</b>	(Tray Type)	<b>Barcode ? None</b>
4	Clean syringe with solvent from Wash1 selected number of times	<b>Pre Cln Slv1</b>	<b>SYRINGE Wash1 Waste</b>	(Syringes) (Wash Stations) (Injectors)	<b>Fill Speed Eject Speed Needle Penetr Clean Volume Needle Penetr</b>
5	Clean syringe with solvent from Wash2 selected number of times	<b>Pre Cln Slv2</b>	<b>SYRINGE Wash2 Waste2</b>	(Syringes) (Wash Stations) (Injectors)	<b>Fill Speed Eject Speed Needle Penetr Clean Volume Needle Penetr</b>
6	Rinse syringe with sample selected number of times	<b>Pre Cln Spl Sample Volume Fill Volume Fill Speed Pullup Delay</b>	<b>SYRINGE TRAY Waste</b>	(Syringes) (Tray Type) (Injectors)	<b>Eject Speed Needle Penetr Needle Penetr</b>
7	Fill syringe with sample using several filling strokes; aspirate air outside of vial if Air Volume = 0	<b>1. Sample Vol 1. Air Vol Fill Volume Fill Speed Fill Strokes Pullup Del</b>	<b>SYRINGE TRAY</b>	(Syringes) (Tray Type)	<b>Eject Speed Overfill Needle Penetr</b>
8	Wait for Inject signal		<b>Inject</b>	(Sync Signals)	

**Table 31** "GC-Dual" Cycle

No.	Processing Step	Method Parameter	Object	(Class)	Used Object Value
9	Move to Injector	<b>1. Inject to</b>			
10	Drive needle to penetration depth	<b>1. Inject to</b>	<b>Motor Z+</b>	(Injectors) (Motors)	<b>Needle Penetr Inj Penet Spd</b>
11	Delay	<b>Pre Inj Del</b>			
12	Activate Injected signal		<b>Injected</b>	(Out Signals)	<b>Pulse Time</b>
13	Activate Injectd+ signal		<b>Injectd+</b>	(Out Signal)	<b>Pulse Time</b>
14	Dispense syringe contents into first GC Injector	<b>Inject Speed</b>			
15	Delay	<b>Pst Inj Del</b>			
16	Retract needle from injector		<b>Motor Z +</b>	(Motors)	<b>Inj Penet Spd</b>
17	Clean syringe with solvent from Wash1 selected number of times	<b>Int Cln Slv1</b>	<b>SYRINGE Wash1 Waste</b>	(Syringes) (Wash Stations) (Injectors)	<b>Fill Speed Eject Speed Needle Penetr Clean Volume Needle Penetr</b>
18	Clean syringe with solvent from Wash2 selected number of times	<b>Int Cln Slv2</b>	<b>SYRINGE Wash2 Waste2</b>	(Syringes) (Wash Stations) (Injectors)	<b>Fill Speed Eject Speed Needle Penetr Clean Volume Needle Penetr</b>

**Table 31** "GC-Dual" Cycle

No.	Processing Step	Method Parameter	Object	(Class)	Used Object Value
19	Fill syringe with sample from job sample number incremented by 2. Sample Offs using several filling strokes; aspirate air outside of vial if Air Volume = 0	<b>2. Sample Offs</b> <b>2. Sample Vol</b> <b>2. Air Vol</b> <b>Fill Volume</b> <b>Fill Speed</b> <b>Fill Strokes</b> <b>Pullup Del</b>	<b>SYRINGE</b> <b>TRAY</b>	(Syringes) (Tray Type)	<b>Eject Speed</b> <b>Overfill</b> <b>Needle</b> <b>Penetr</b>
20	Wait for Inject2 signal		<b>Inject2</b>	(Sync Signals)	
21	Move to second GC Injector	<b>2. Inject to</b>			
22	Wait for time since first injection	<b>Inj Time Diff</b>			
23	Drive needle to penetration depth	<b>2. Inject to</b>	<b>Motor Z+</b>	(Injectors) (Motors)	<b>Needle</b> <b>Penetr</b> <b>Inj Penet Spd</b>
24	Delay	<b>Pre Inj Del</b>			
25		<b>Activate Injectd2 signal</b>	<b>Injectd2+</b>	(Out Signals)	<b>Pulse Time</b>
26	Dispense syringe contents into second GC Injector	<b>Inject Speed</b>			
27	Delay	<b>Pst Inj Del</b>	<b>Motor Z+</b>	(Motors)	<b>Inj Penet Spd</b>
28	Retract needle from injector				
29	Clean syringe and needle with solvent 1	<b>Pst Cln Slv1</b>	<b>SYRINGE</b> <b>Wash1</b> <b>Waste</b>	(Syringes) (Wash Stations) (Injectors)	<b>Fill Speed</b> <b>Eject Speed</b> <b>Needle</b> <b>Penetr</b> <b>Needle</b> <b>Penetr</b>

**Table 31** "GC-Dual" Cycle

<b>No.</b>	<b>Processing Step</b>	<b>Method Parameter</b>	<b>Object</b>	<b>(Class)</b>	<b>Used Object Value</b>
30	Clean syringe and needle with solvent 2	<b>Pst Cln Slv2</b>	<b>SYRINGE Wash2 Waste2</b>	(Syringes) (Wash Stations) (Injectors)	<b>Fill Speed Eject Speed Needle Penetr Needle Penetr</b>
31	Move to Home position		<b>Home</b>	(Positions)	

## "GC-Dual" Cycle Method Parameter Description

**Table 32** "GC-Dual" Cycle Method Parameter Description

<b>Parameter</b>	<b>Description</b>
<b>CYCLE</b>	GC-Dual
<b>SYRINGE</b>	Selected syringe
<b>1. Sample Vol</b>	Sample volume for first injection
<b>1. Air Vol</b>	Volume aspirated after the syringe needle is moved out of the sample liquid
<b>1. Inject to</b>	Injector used for first injection
<b>Inj Time Diff</b>	Time difference between first and second injection
<b>2. Sample Offs</b>	Offset from first sample number to second sample number
<b>2. Sample Vol</b>	Sample volume for first injection
<b>2. Air Vol</b>	Volume aspirated after the syringe needle is moved out of the sample liquid
<b>2. Inject to</b>	Injector used for second injection
<b>Pre Cln Slv1</b>	Wash cycles with Wash1 before first sample is aspirated
<b>Pre Cln Slv2</b>	Wash cycles with Wash2 before first sample is aspirated
<b>Pre Cln Spl</b>	Rinse cycles with sample before first sample is aspirated
<b>Int Cln Slv1</b>	Wash cycles with Wash1 before second sample is aspirated
<b>Int Cln Slv2</b>	Wash cycles with Wash2 before second sample is aspirated
<b>Pst Cln Slv1</b>	Wash cycles with Wash1 after second sample is aspirated
<b>Pst Cln Slv2</b>	Wash cycles with Wash2 after second sample is aspirated
<b>Fill Volume</b>	Fill Volume used for all Filling strokes except the last one
<b>Fill Speed</b>	Speed of plunger movement used to aspirate sample
<b>Fill Strokes</b>	Number of filling strokes
<b>Pullup Del</b>	Delay time between sample pullup and ejection
<b>Inject Speed</b>	Speed of plunger movement used during sample injection

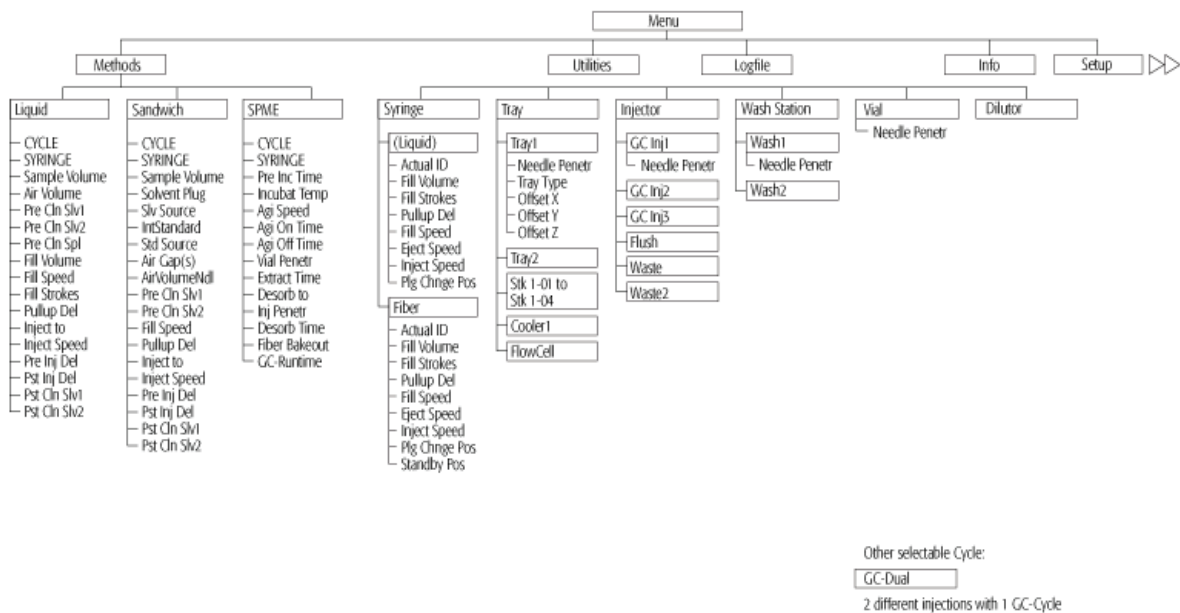
**Table 32** "GC-Dual" Cycle Method Parameter Description

<b>Parameter</b>	<b>Description</b>
<b>Pre Inj Del</b>	Delay time prior to sample injection
<b>Pst Inj Del</b>	Delay time after sample injection

## Software Flow Chart

### Flow Chart based on Firmware Level 2.5.X.

**PAL** SYSTEM GC Firmware Overview



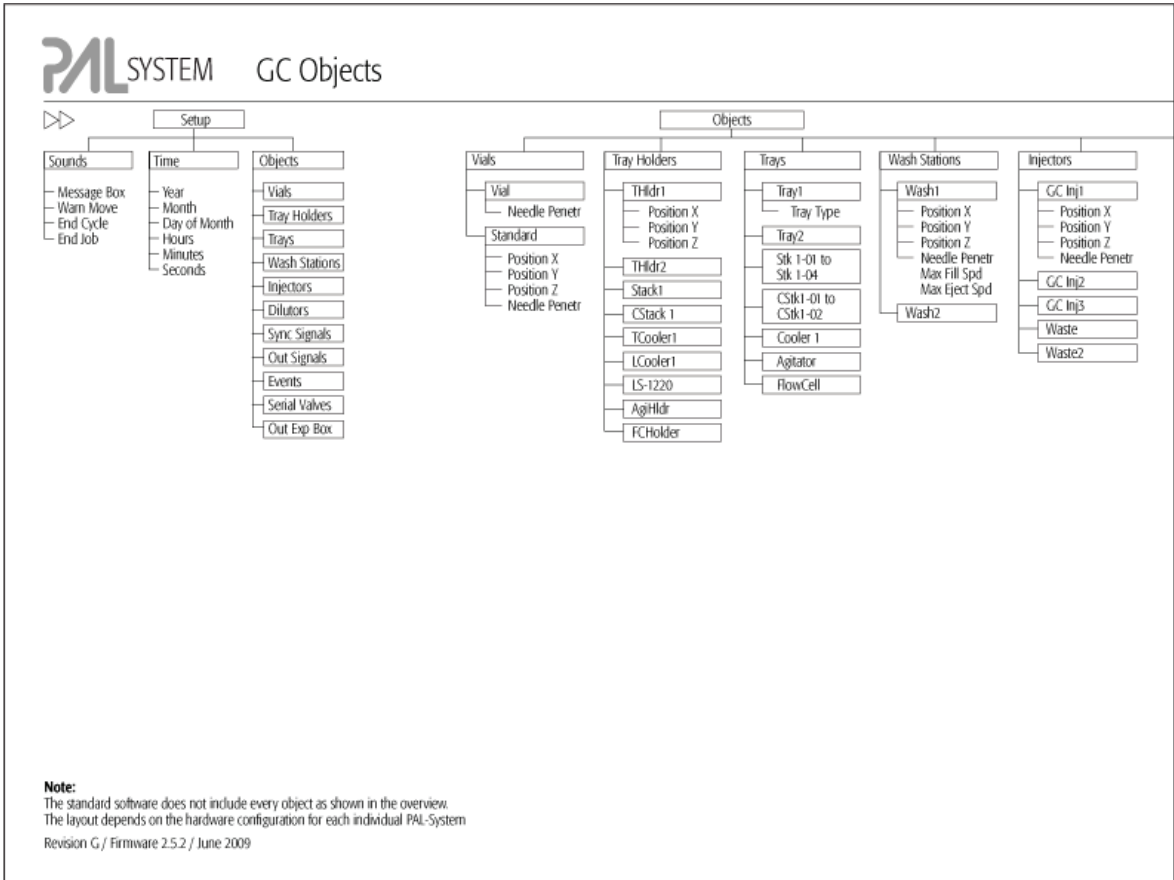
**Notes:**  
Plunger Stroke and Injection Counter  
Menu/Info/Maintenance

The standard software does not include every object as shown in the overview.  
The layout depends on the hardware configuration for each individual PAL-System

Revision G / Firmware 2.5.2 / June 2009

**Figure 38** GC Firmware Overview, Page 1

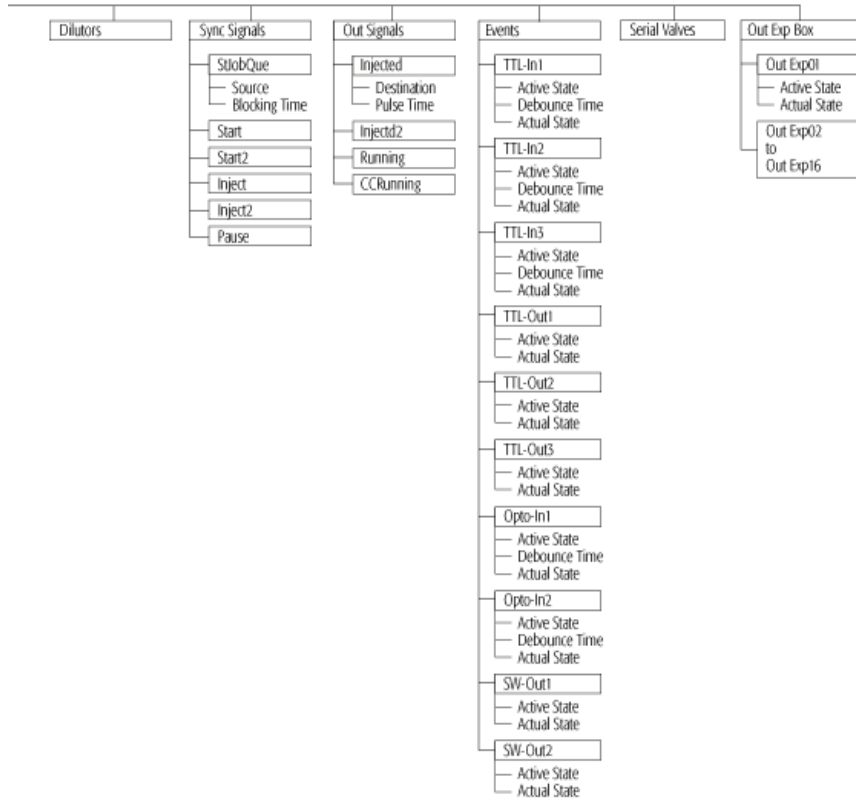




**Figure 39** GC Firmware Overview, Page 2

## 4 Appendices

### Software Flow Chart



PAL is a registered trademark of CTC Analytics AG | Switzerland

**Figure 40** GC Firmware Overview, Page 3

Method Cycle	Recommended PAL Method Parameters		
	Split Injection	On-Column Injection PTV Inject Cold	Packed Columns Flush Vapourising
<b>Liquid</b>			
CYCLE	GC -Inj	GC -Inj	GC -Inj
SYRINGE	10 µl	10 µl	10 µl
Sample Volume	1.0 µl	1.0 µl	1.0 µl
Air Volume	0.5 to 1.0 µl	0.5 to 1.0 µl	0.5 to 1.0 µl
Pre Cln SW1	3	3	3
Pre Cln SW2	0	0	0
Pre Cln Spl	2	2	2
Fill Volume	5 µl	5 µl	5 µl
Fill Speed	2 µl/s	2 µl/s	2 µl/s
Fill Strokes	5	5	5
Pullup Del	5 s	5 s	5 s
Inject to	GC Inj 1	GC Inj 1	GC Inj 1
Inject Speed	50 µl/s	1 to 5 µl/s	5 to 20 µl/s
Pre Inj Del	0 ms	0 ms	0 ms
Pat Inj Del	0 ms	3 to 5 s	5 to 20 s
Pat Cln SW1	3	3	3
Pat Cln SW2	0	0	0

- Eject Speed for 10 µL Syringe: 30-50 µL/s (Utilities / Syringe)
- Pre Clean Solvent 2 is used for samples with components having extremely different polarities.
- Pre Injection Delay is used for highly viscous samples. Length of time needle will be heated in hot injector.
- Needle Penetration Injector (Utilities / Injector). Value differs from injector manufacturer to manufacturer.

Method Cycle

**Headspace**

GC PAL can not be upgraded for the Headspace Technique.

Method Cycle	Recommended PAL Method Parameters		
	Split Injection	On-Column Injection PTV Inject Cold	Packed Columns Flush Vapourising
<b>Sandwich</b>			
CYCLE	GC -InjS	GC -InjS	GC -InjS
SYRINGE	10µl	10 µl	10 µl
Sample Volume	0.2 to 1 µl	0.2 to 1 µl	0.2 to 2 µl
Solvent Plug	0.5 to 1 µl	0.5 to 1 µl	0.5 to 1 µl
Slv Source	Wash	Wash	Wash
IntStandard	0 to 1 µl	0 to 1 µl	0 to 1 µl
Std Source	Standard	Standard	Standard
Air Gap(s)	0.5 to 1.0 µl	0.5 to 1.0 µl	0.5 to 1.0 µl
AirVolumeNcl	0.8 to 1.0 µl	0.8 to 1.0 µl	0.8 to 1.0 µl
Pre Cln SW1	3	3	3
Pre Cln SW2	0	0	0
Pre Cln Spl	2	2	2
Fill Speed	2 µl/s	2 µl/s	2 µl/s
Pullup Del	3 to 5 s	3 to 5 s	3 to 5 s
Inject to	GC Inj 1	GC Inj 1	GC Inj 1
Inject Speed	30 - 50 µl/s	1 - 5 µl/s	5 - 20 µl/s
Pre Inj Del	0 ms	0 ms	0 ms
Pat Inj Del	0 ms	3 to 5 s	5 to 20 s
Pat Cln SW1	3	3	3
Pat Cln SW2	0	0	0

- Sandwich Cycle: Mainly used to inject sample volumes < 1.0 µL with a 10 µL Standard Syringe.
- Solvent Plug: Select Source vial e.g. Position "Wash" from Wash Station
- IntStandard: Select Source Vial for Internal Standard or Reagent Solution e.g. Position "Standard" from Wash Station, Internal Standard will be added in the Syringe (not from one sample solution)
- Reagent: Example: Esterification of organic acids spontaneous in hot injector

Method Cycle

Recommended PAL Method Parameters

Remarks

**SPME**

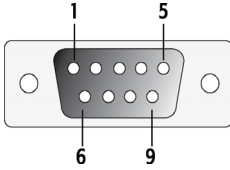
CYCLE	SPME	
SYRINGE	Fiber	
Pre Inc Time	0 or several minutes	Pre Incubation time to equilibrate sample before fiber is inserted
Incub Temp	35 to 200 °C	Application and fiber dependent
Agit Speed	250 to 750 rpm	Speed for pre-incubation process only
Agit On Time	5 s	On time for pre-incubation process and extract time
Agit Off Time	2 s	Off time for pre-incubation process and extract time
Vial Penetr	22 to 31 mm	Adjust sample volume in vial accordingly
Extract Time	open	Application dependent method development (ab-adsorption)
Desorb to	GC Inj 1	
Inj Penetr	35 to 45 mm	Depends on type of injector
Desorb Time	2 to 5 min	Thermal desorption within ms, longer time for fiber clearing
Fiber Bakeout	0	If time is > 0: Fiber conditioning station will be used for clearing
GC Runtime	open	GC Cycle time from "ready-to-ready" status

Part No.: PAL\_Firmware\_GC

Figure 41 GC Firmware Overview, Page 4

## External Connectors

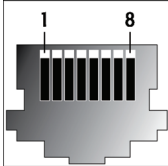
### Connector SER1

Connector SER1	Pin	Signal Name
		
	1	NC
	2	RXD
	3	TXD
	4	DTR <sup>1</sup>
	5	GND
	6	NC
	7	RTS <sup>2</sup>
	8	NC
	9	NC

<sup>1</sup> Bridged with Pin7; Special grounding, do not alter.

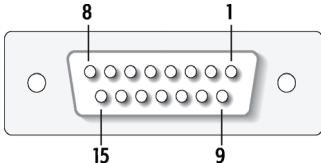
<sup>2</sup> Bridged with Pin 4; Do not alter.

## Connector TERMINAL or SER3

Connector TERMINAL or SER3	Pin	Signal Name
	1	GND
	2	RXD
	3	TXD
	4	NC
	5	NC
	6	+5 V
	7	NC
	8	GND

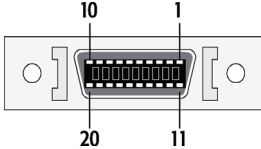
## Connector INTERFACE 1\*

\* APR Control-GC Injector 80 Board: "INTERFACE" and not "INTERFACE1"

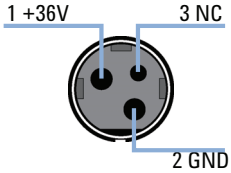
Connector INTERFACE 1	Pin	Signal Name
	1	Pwr-Out1 +
	2	Pwr-Out2 +
	3	SW-Out1 N0
	4	SW-Out1 COM
	5	SW-Out2 N0
	6	Opto-In1 +
	7	TTL-In1 +
	8	GND
	9	Pwr-Out1 -
	10	Pwr-Out2 -
	11	TTL-In2
	12	SW-Out2 COM
	13	TTL-In3
	14	Opto-In1 -
	15	+5 V

## Connector AUX1 \*

\* APRControl-GC Injector 80 Board: "AUX" and not "AUX1"

Connector AUX1	Pin	Signal Name
	1,2	Motor A1
	11, 12	Motor A2
	3, 4	Motor B1
	13, 14	Motor B2
	15, 18, 19	GND
	6	Temp +
	16	Temp -
	7	Sens
	17	+5 V
	8, 9	Heater
	10,20	+36 V

## Connector Power

Connector POWER	Pin	Signal Name
		
	1	+36 V
	2	GND
	3	NC



## Accessories

The accessories for the System are described on the web page  
<http://www.chem.agilent.com>.

# Index

## A

accessories 137  
 AUX1  
   connector 135

## B

board 104

## C

capacity  
   sample 45  
 carryover 101  
 components  
   unpacking 49  
 connector  
   AUX1 135  
   interface 1 134  
   power 136  
   SER1 132  
   SER3 133  
   terminal 133  
 control terminal 15  
 control 104  
 control-xt board  
   HTC 105  
 cycle  
   "GC-Dual" method parameter  
   description 126  
   "GC-Dual" 122  
   "gc-inj" parameter description 117  
   "GC-Inj" 114  
   "GC-InjS" method parameter  
   description 121  
   "GC-InjS" 118

## D

detector signal  
   no 99  
   very low 99  
 dilutor  
   function key 31  
   item 31

## E

electrical connections 58  
 electrical specifications 46  
 enter button 17  
 error message 99  
 extended user mode  
   access 79

## F

f3-setup 80, 86  
 free items 37  
 free objects 37  
 function key  
   wash station 29  
 function key  
   dilutor 31  
   injector 28  
 function keys 17  
 function key  
   syringe 25  
   tool 32  
   tray 27  
   vial 30  
 function  
   info 34

## H

hardware  
   item 35

## I

info function 34  
 injection cycle  
   "GC-Dual" 122  
   "GC-Inj" 114  
   "GC-InjS" 118  
 injection range  
   liquid 45  
 injection unit  
   collision 101  
   installing 51  
 injector  
   function key 28  
   item 28  
 injectors 70  
 installing  
   injection unit 51  
   keypad terminal 54  
   power supply 55  
   trayholder 57  
   wash station 56  
 interface 1  
   connector 134  
 item  
   dilutor 31  
   hardware 35  
   injector 28  
   maintenance 36  
   software 35

## Index

- tool 32
  - vial 30
  - wash station 29
- J**
- job queue
    - building and starting 22
  - job queue
    - aborting 23
    - restarting 23
  - job 21
- K**
- keypad terminal
    - installing 54
  - keys
    - ESCape and STOP 17
- L**
- loader program 78
- M**
- maintenance 107
    - item 36
  - menu screens 16
  - methods
    - creating 18
    - delete 20
    - edit/view 20
- N**
- naming
    - convention 113
- O**
- object
    - not detected 102
  - objects 40, 86
- output signals 75
- P**
- performance specification 45
  - power supply
    - installing 55
  - priming
    - syringe 71
- R**
- reference positions
    - defining 59
  - replicate injections 45
  - requirements
    - operating and environmental 47
- S**
- safety information 6
  - sample tray
    - thermostatted 45
  - sample volume 45
  - sample
    - capacity 45
  - scroll knob 17
  - service 85
  - setup functions 38
  - software
    - item 35
  - sound pressure level 48
  - sounds 39
  - special function 79
  - specifications
    - physical 47
  - synchronization 75
  - syringe
    - function key 25
    - installing 72
    - items 25
  - priming 71
  - removing 74
  - syringes 71
  - system 82
    - overview 43
- T**
- terms
    - definition 110
  - time 39
  - tool
    - function key 32
    - item 32
  - tools 32
  - tray column
    - definition 64
  - tray holder 62
  - tray row
    - definition 64
  - tray type 90
  - tray
    - function key 27
  - trayholder
    - installing 57
  - tray 27
    - items 27
  - trays 63, 95
  - troubleshooting 99
- U**
- utility functions 24
- V**
- vial
    - function key 30
    - item 30
  - vials
    - standard position 69

## Index

### W

wash station

wash 1/wash2 reference point 67

wash station

function key 29

installing 56

item 29

waste/waste2 reference point 68



[www.agilent.com](http://www.agilent.com)

## In This Book

This manual contains technical reference information about the Agilent GC Injector 80.

The manual describes the following:

- safety information,
- operating instructions,
- description and installation,
- troubleshooting,
- replacing parts and
- maintaining.

© Agilent Technologies 2010

Printed in Germany  
08/2010



G6502-90000