

Owner's Manual & Safety Instructions

Save This Manual Keep this manual for the safety warnings and precautions, assembly, operating, inspection, maintenance and cleaning procedures. Write the product's serial number in the back of the manual near the assembly diagram (or month and year of purchase if product has no number). Keep this manual and the receipt in a safe and dry place for future reference.

21c

350 LB. CAPACITY

HaulMaster®

52³/₄" LONG

TRUCK BED EXTENDER



Visit our website at: <http://www.harborfreight.com>
Email our technical support at: productsupport@harborfreight.com

69650

When unpacking, make sure that the product is intact and undamaged. If any parts are missing or broken, please call 1-888-866-5797 as soon as possible.

Copyright© 2021 by Harbor Freight Tools®. All rights reserved.

No portion of this manual or any artwork contained herein may be reproduced in any shape or form without the express written consent of Harbor Freight Tools. Diagrams within this manual may not be drawn proportionally. Due to continuing improvements, actual product may differ slightly from the product described herein. Tools required for assembly and service may not be included.

⚠ WARNING

Read this material before using this product. Failure to do so can result in serious injury. **SAVE THIS MANUAL.**

Specifications

Load Capacity	350 lb.
Hitch Receiver Size	Fits 2" Square Receivers
Note: A class 3 truck hitch is required.	

Important Safety Information

General Safety

1. Make sure the area in which the Extender is assembled is clean and well lit. *Cluttered or dark areas invite accidents.*
2. Keep children and bystanders away while assembling the Extender.
3. Stay alert, watch what you are doing and use common sense when using the Extender. Do not use the Extender while you are tired or under the influence of drugs, alcohol or medication. *A moment of inattention while using the Extender may result in serious personal injury.*

Extender Use and Care

1. Use the correct Extender for your application. *The correct Extender will do the job better and safer at the rate for which it was designed.*
2. Store the Extender out of reach of children and do not allow people unfamiliar with the Extender or these instructions to use the Extender. *Use of Extender by untrained people may not be safe.*
3. Maintain the Extender. Check for misalignment or binding of moving parts, breakage of parts and any other condition that may affect the Extender's operation. If damaged, have the Extender repaired before use. *Many accidents are caused by poorly maintained equipment.*
4. Use this Extender in accordance with these instructions and in the manner intended for this particular type of product, taking into account the area conditions and the task to be performed. *Use of this Extender for operations different from those intended could result in a hazardous situation.*

Service

Have this Extender serviced by a qualified repair person using only identical replacement parts. *This will ensure that the safety of the Extender is maintained.*

Specific Safety Rules

1. Follow DOT guidelines for installation and use.
2. Do not exceed 350 lb. capacity, evenly distributed. Be aware of dynamic loading! Sudden load movement may briefly create excess load causing product failure.
3. Secure load before moving.
4. Tie warning flag to the end of extended loads.
5. Turn vehicle's ignition OFF, set parking brake, and chock wheels before installing, loading, or unloading.
6. Use as intended only.
7. Inspect before use; do not use if parts loose or damaged.
8. Wear ANSI-approved safety goggles and heavy-duty work gloves during installation, loading, and unloading.
9. Maintain labels and nameplates on the Extender. These carry important safety information. If unreadable or missing, contact Harbor Freight Tools for a replacement.
10. Keep Extender clean and dry.
11. This product is not a toy. Keep it out of reach of children.
12. Make sure to secure load with ropes, and/or tie-downs before transporting.
13. Load heaviest items toward the center of the Extender.
14. Only use Extender with a properly installed Class III 2 inch hitch receiver capable of supporting the Extender and its load.
15. The warnings, cautions, and instructions discussed in this instruction manual cannot cover all possible conditions and situations that may occur. It must be understood by the operator that common sense and caution are factors which cannot be built into this product, but must be supplied by the operator.



SAVE THESE INSTRUCTIONS.

Setup - Before Use:



Read the **ENTIRE IMPORTANT SAFETY INFORMATION** section at the beginning of this manual including all text under subheadings therein before set up or use of this product.

Note: For additional information regarding the parts listed in the following pages, refer to Parts List and Assembly Diagram on page 7.

Turn vehicle's ignition OFF, set parking brake, and chock wheels before assembly.

Assembly

1. With the short end of the L-Extension (4) facing up, slide the long end into the receiver hitch (not included).
2. Insert an Angled Pin (2) through the hitch and L-Extension (4).
3. Secure with a R-Pin (3) through the hole in the Angled Pin (2).
4. Slide the Warning Flag (5) onto the remaining Angled Pin (2).
5. The T-Support (1) has five holes to change the height. Line up the hole on the T-Support (1) with the desired hole on the L-Extension (4).
6. Insert the Angled Pin (2) with the Warning Flag through T-Support and L-Extension.
7. Secure with the remaining R-Pin (3).
8. Pull out on the L-Extension and T-Support to make sure they are properly locked in place.

Functions

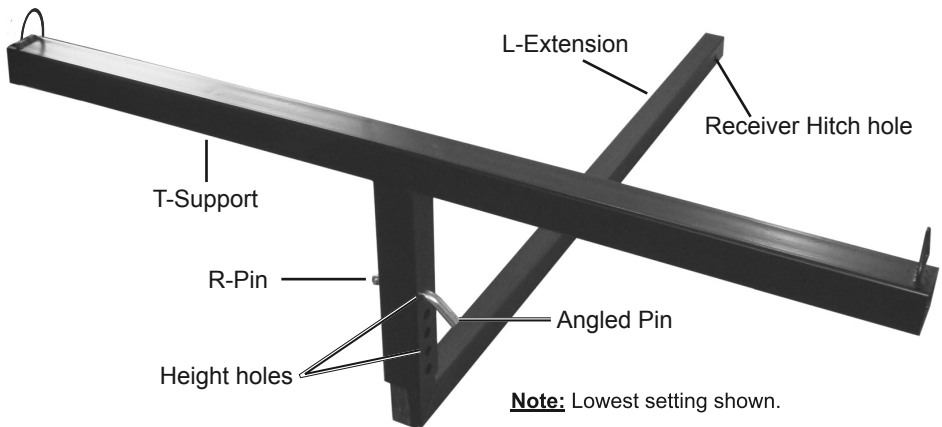

Figure A: Components

Operation Instructions



Read the ENTIRE IMPORTANT SAFETY INFORMATION section at the beginning of this document including all text under subheadings therein before set up or use of this product.

⚠️ WARNING

TO PREVENT SERIOUS INJURY: Make sure the vehicle is turned off and in gear or park, with the emergency brake engaged and the wheels blocked.

**Make sure the Extender is secured onto the vehicle.
Make sure the Extender is clean and dry before loading.**

Do not exceed this Extender's maximum weight capacity of 350 pounds.

All persons not involved in loading or unloading the Extender must stand clear of the unit.

1. Attach the Truck Extender to the vehicle as explained in the Assembly instructions.
2. Load the Truck Extender, making sure the objects are secured in the truck bed so they will not tip up out of the bed and over the Truck Extender.
3. Secure the load to the Truck Extender with appropriate lashing materials (not included).
4. Remove the Truck Extender from the vehicle when not in use.

NOTICE! Contact local Department of Transportation to verify all safety guidelines are being followed before transporting load.

CAUTION! Do not exceed 350 lb. capacity. Be aware of dynamic loading. Sudden load movement may briefly create excess load causing product failure.

Note: The Truck Extender and load will increase the overall vehicle length. Use care when parking, turning, or backing up with the load attached.



Maintenance and Servicing



Procedures not specifically explained in this manual must be performed only by a qualified technician.

⚠️ WARNING

TO PREVENT SERIOUS INJURY:

Remove load from the Extender before performing any maintenance or service.

Do not use damaged equipment. If the Extender is damaged have the problem corrected before further use.

Cleaning, Maintenance, and Lubrication

1. **BEFORE EACH USE**, inspect the general condition of the Extender. Check for:
 - loose hardware, weld fractures, excessive rust,
 - misalignment or binding of parts,
 - cracked or broken parts, bent pins, and
 - any other condition that may affect its safe operation.
2. Clean the Extender after each use. Make sure dirt, oil, grease, and debris are not on the Extender.

PLEASE READ THE FOLLOWING CAREFULLY

THE MANUFACTURER AND/OR DISTRIBUTOR HAS PROVIDED THE PARTS LIST IN THIS DOCUMENT AS A REFERENCE TOOL ONLY. NEITHER THE MANUFACTURER OR DISTRIBUTOR MAKES ANY REPRESENTATION OR WARRANTY OF ANY KIND TO THE BUYER THAT HE OR SHE IS QUALIFIED TO MAKE ANY REPAIRS TO THE PRODUCT, OR THAT HE OR SHE IS QUALIFIED TO REPLACE ANY PARTS OF THE PRODUCT. IN FACT, THE MANUFACTURER AND/OR DISTRIBUTOR EXPRESSLY STATES THAT ALL REPAIRS AND PARTS REPLACEMENTS SHOULD BE UNDERTAKEN BY CERTIFIED AND LICENSED TECHNICIANS, AND NOT BY THE BUYER. THE BUYER ASSUMES ALL RISK AND LIABILITY ARISING OUT OF HIS OR HER REPAIRS TO THE ORIGINAL PRODUCT OR REPLACEMENT PARTS THERETO, OR ARISING OUT OF HIS OR HER INSTALLATION OF REPLACEMENT PARTS THERETO.

Parts List and Assembly Diagram

Part	Description	Qty
1	T-Support	1
2	Angled Pin	2
3	R-Pin	2

Part	Description	Qty
4	L-Extension	1
5	Warning Flag (not shown)	1

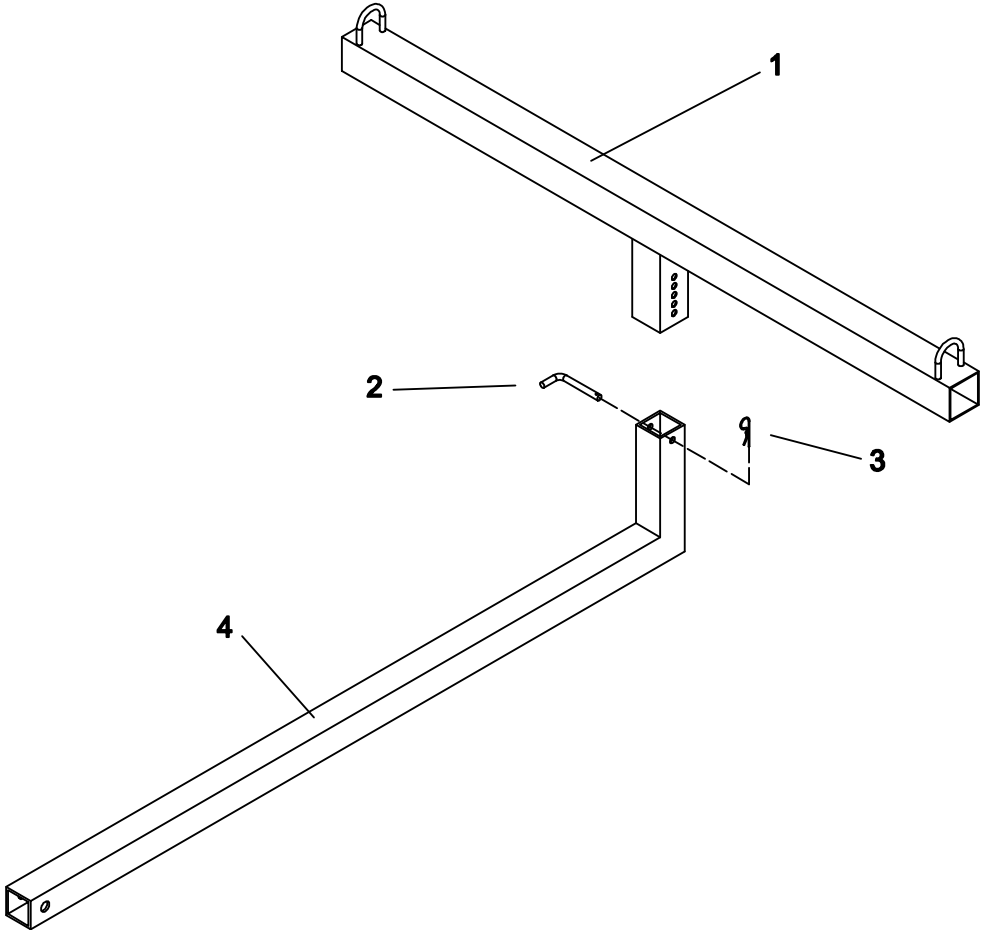

Record Serial Number Here:

Note: If product has no serial number, record month and year of purchase instead.

Note: Some parts are listed for illustration purposes only, and are not available individually as replacement parts. Specify UPC 193175311191 when ordering parts.

Limited 90 Day Warranty

Harbor Freight Tools Co. makes every effort to assure that its products meet high quality and durability standards, and warrants to the original purchaser that this product is free from defects in materials and workmanship for the period of 90 days from the date of purchase. This warranty does not apply to damage due directly or indirectly, to misuse, abuse, negligence or accidents, repairs or alterations outside our facilities, criminal activity, improper installation, normal wear and tear, or to lack of maintenance. We shall in no event be liable for death, injuries to persons or property, or for incidental, contingent, special or consequential damages arising from the use of our product. Some states do not allow the exclusion or limitation of incidental or consequential damages, so the above limitation of exclusion may not apply to you. THIS WARRANTY IS EXPRESSLY IN LIEU OF ALL OTHER WARRANTIES, EXPRESS OR IMPLIED, INCLUDING THE WARRANTIES OF MERCHANTABILITY AND FITNESS.

To take advantage of this warranty, the product or part must be returned to us with transportation charges prepaid. Proof of purchase date and an explanation of the complaint must accompany the merchandise. If our inspection verifies the defect, we will either repair or replace the product at our election or we may elect to refund the purchase price if we cannot readily and quickly provide you with a replacement. We will return repaired products at our expense, but if we determine there is no defect, or that the defect resulted from causes not within the scope of our warranty, then you must bear the cost of returning the product.

This warranty gives you specific legal rights and you may also have other rights which vary from state to state.

