

Getting Started with Traveo II Family MCUs

About this document

Scope and purpose

AN220118 briefly introduces you to Traveo™ II family, an Arm® Cortex®-M4F, M7, and M0+-based microcontroller. This application note also guides you to set up the Traveo II development environment.

Associated Part Family

CYT2/CYT3/CYT4 Series

Table of contents

About this document	1
Table of contents	1
1 Introduction	3
2 Feature Set	4
2.1 CYT2B Series	4
2.1.1 Function Summary.....	4
2.2 CYT4B Series	5
2.2.1 Function Summary.....	6
2.3 CYT4D Series	6
2.3.1 Function Summary.....	7
2.4 Other Series	8
3 Development Environment and Tools	9
3.1 Evaluation Board.....	9
3.1.1 Functions Available on the Base Board.....	9
3.1.2 Connection Diagram with Tools	10
3.2 Sample Driver Library.....	11
3.2.1 SDL Structure	11
3.2.2 CPU (CM0+ and CM4) Startup Sequence for CYT2B Series	14
3.2.3 CPU (CM0+ and CM7) Startup Sequence for CYT4B/CYT4D Series	15
3.2.4 Startup Flow Example.....	15
3.2.5 Sample Code	18
3.3 Peripheral Drivers.....	24
3.3.1 Peripheral Drivers List.....	24
3.4 Example Usage of SDL with GHS MULTI	26
3.4.1 Environment for SDL.....	26
3.4.2 Install GHS MULTI and SDL	26
3.4.3 Setup Debug Script and Configuration files.....	26
3.4.4 Setup with MULTI	27
3.4.4.1 Debugging with Download on the RAM.....	29
3.4.4.2 Debugging with download on the Flash Memory	32
3.5 Example Usage of SDL with IAR Embedded Workbench for Arm	35

Introduction

3.5.1	Environment for SDL.....	35
3.5.2	Install GHS MULTI and SDL	35
3.5.3	Setup with IAR EWARM.....	35
3.5.3.1	Debugging with Download on the RAM.....	35
3.5.3.2	Debugging with Download on the Flash Memory.....	38
3.6	Development Tools	41
3.7	Flash Programming Tools	41
4	Summary	42
5	Glossary	43
6	Related Documents	44
	Revision history.....	45

Introduction

1 Introduction

This application note provides an overview of the feature set and describes the development environment and tools to get started with the CYT2, CYT3, and CYT4 series of MCUs from the Traveo II family. Every member of these series includes an Arm® Cortex®-M based CPU core with CAN FD, memory, and analog and digital peripheral functions in a single chip. The CYT2 series has one Arm Cortex-M4F-based CPU (CM4) and Cortex-M0+-based CPU (CM0+). The CYT4 series has two Arm Cortex-M7-based CPUs (CM7) and CM0+. The CYT3 series has one CM7 and CM0+. The product lineup of the CYT2B series features 64-pin to 176-pin LQFP packages. The product lineup of the CYT4B series features 176-pin TEQFP to 320-BGA packages. The product lineup of the CYT4D series features 327-BGA and 500-BGA package. The product lineup of the CYT3BB and CYT4BB series features 100-pin TEQFP to 272-BGA packages. To better understand the functionality described and terminology used in this application note, it is a good idea to read the “Getting Started” chapter of the Architecture Technical Reference Manual (Architecture TRM). See [Related Documents](#) in this application note for more details.

Feature Set

2 Feature Set

2.1 CYT2B Series

CYT2B series comprises Traveo II MCUs targeted at automotive systems such as body-control units. These devices are based on Arm Cortex-M4 CPU for primary processing, along with a separate Cortex-M0+ CPU for peripheral and security processing. They are manufactured using an advanced 40-nm process. Each device supports automotive body-control functions such as Controller Area Network with Flexible Data rate (CAN FD) and Local Interconnect Network (LIN). These products enable a secure computing platform, and incorporate Cypress' low-power flash memory, along with multiple high-performance analog and digital functions. **Figure 1** shows the block diagram of CYT2B9.

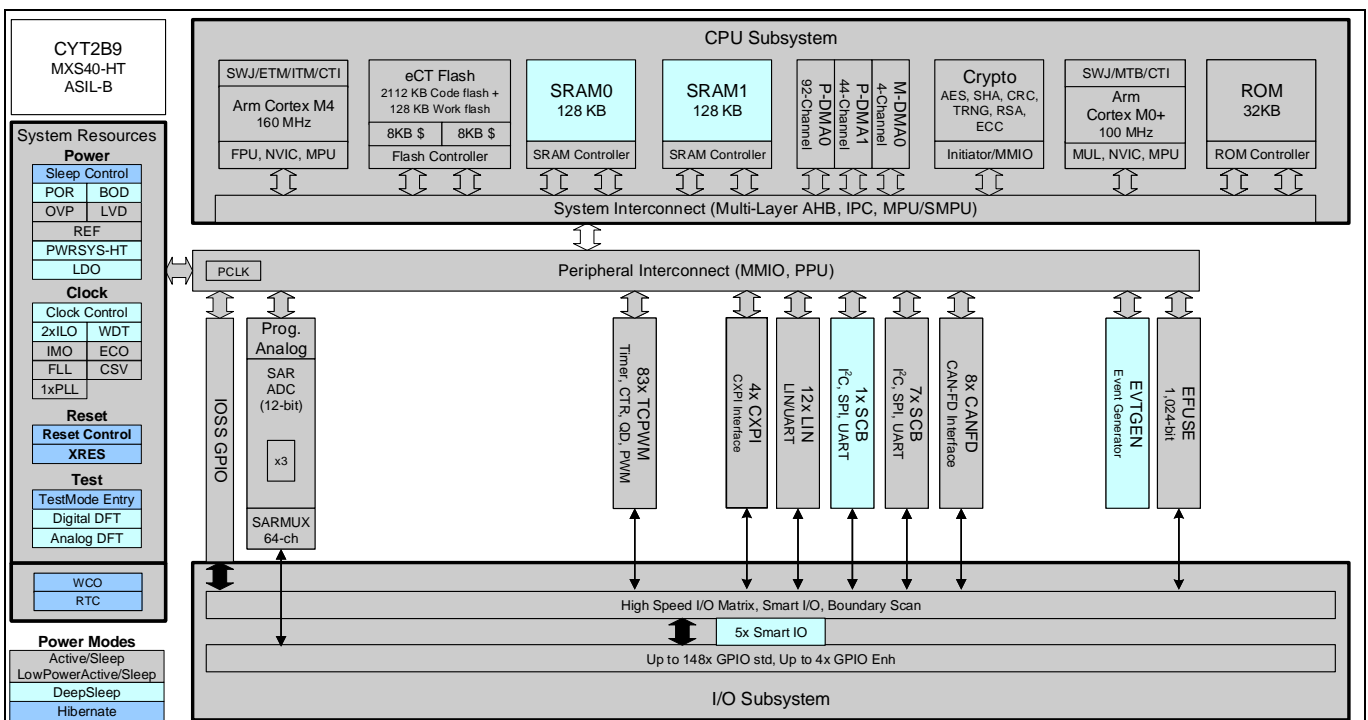

Figure 1 Block Diagram of CYT2B9

2.1.1 Function Summary

- Dual-CPU subsystem
 - 160-MHz 32-bit CM4 with single-cycle multiply, floating point, and Memory Protection Units (MPUs)
 - 100-MHz 32-bit CM0+ with MPU
- Integrated Memories
 - Up to 2112 KB (1984 KB + 128 KB) of code flash along with Up to 128 KB (96 KB + 32 KB) of work flash
 - Read-While-Write (RWW) allows updating the code flash/work flash while executing from code flash
 - Support for single and dual bank mode
- CAN FD
 - Increased data rate compared to classic CAN, only limited by physical layer topology and devices (transceivers)
 - Supports up to 8 Mbps
 - Supports up to six CAN FD channels

Feature Set

- Conforms to ISO 11898-1:2015 standard
- CXPI (supported only on CYT2B9; not supported on CYT2B7)
- Crypto engine
- Functional safety for ASIL-B
- Low-power 2.7 V to 5.5 V operation
- Debug interface
- JTAG controller and interface compliant with IEEE-1149.1-2001, SWD protocol
 - Flash programming on JTAG I/F and SWD
- Compatible with industry-standard tools
 - Green Hills Software (GHS) MULTI or IAR Embedded Workbench for Arm (EWARM) for code development and debugging
 - Supports Arm Embedded Trace Macrocell (ETM) Trace for Cortex-M4 processor
- Package lineup: LQFP-64/80/100/144/176 pin

2.2 CYT4B Series

CYT4B series comprises Traveo II MCUs targeted at automotive systems such as high-end body control units. These devices have two CM7 CPUs for primary processing, and a CM0+ CPU for peripheral and security processing. They are manufactured using an advanced 40-nm process. Each device supports automotive body control functions such as CAN FD, LIN, Gigabit Ethernet, and FlexRay. These products enable a secure computing platform, and incorporate Cypress' low-power flash memory, along with multiple high-performance analog and digital functions. **Figure 2** shows the block diagram of CYT4BF.

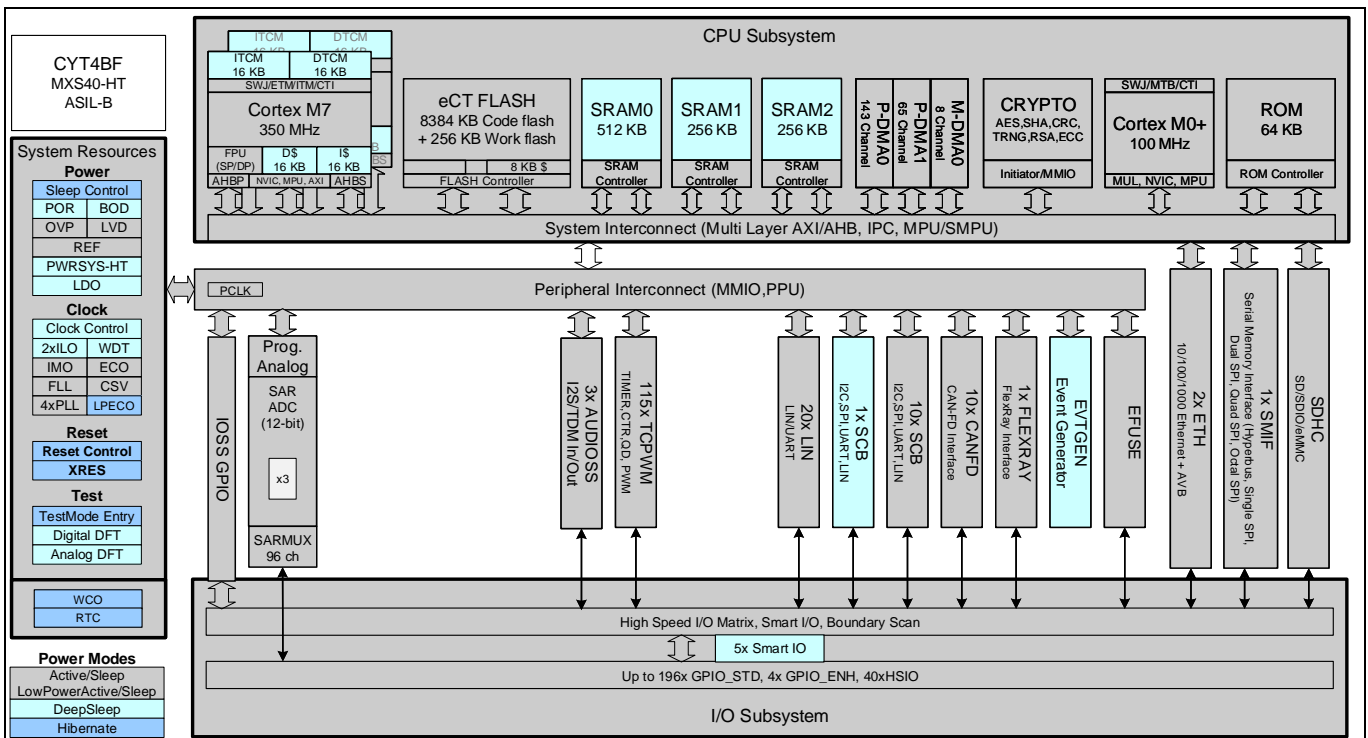

Figure 2 Block Diagram of CYT4BF

Feature Set

2.2.1 Function Summary

- Dual-CPU subsystem
 - Two 350-MHz 32-bit Arm Cortex-M7 CPUs, each with single-cycle multiply, and single/double-precision floating point unit (FPU) and memory protection units (MPUs)
 - 100-MHz 32-bit CM0+ with MPU
- Integrated memories
 - Up to 8384 KB (8128 KB + 256 KB) of code flash along with Up to 256 KB (192 KB + 64 KB) of work flash
 - Read-While-Write (RWW) allows updating the code flash/work flash while executing from code flash
 - Support for single and dual bank mode
- CAN FD
 - Increased data rate compared to classic CAN, only limited by physical layer topology and devices (transceivers)
 - Supports up to 8 Mbps
 - Supports up to 10 CAN FD channels
 - Conforms to ISO11898-1:2015 standard
- Ethernet MAC
 - Up to 2 ch × 10/100/1000
- FlexRay
 - 1 interface of FlexRay supporting ch A and ch B (option)
- SMIF (Serial Memory Interface)
 - HyperBus, Single SPI, Dual SPI, Quad SPI, Octal SPI
- SDHC
 - embedded MultiMedia Card (eMMC), or Secure Digital (SD), or SDIO (Secure Digital Input Output)
- Audio
 - Three Inter-IC Sound (I²S)/Time Division Multiplexing (TDM) interfaces
- Crypto engine
- Functional safety for ASIL-B
- Single power supply: $V_{DD} = 2.7\text{ V to }5.5\text{ V}$ (Up to 300 mA) / Dual power supply: $V_{DD} = 2.7\text{ V to }5.5\text{ V}$ and $V_{CCD} = 1.15\text{ V}$ (Exceeds 300 mA)
- Debug interface
- JTAG controller and interface compliant IEEE-1149.1-2001, SWD protocol
 - Flash programming on JTAG I/F and SWD
- Compatible with industry-standard tools
 - GHS/MULTI or IAR EWARM for code development and debugging
 - Supports Arm Embedded Trace Macrocell (ETM) Trace for Cortex-M7 processor
- Package lineup: TEQFP-176 pin, BGA-272, BGA-320

2.3 CYT4D Series

CYT4D series comprises Traveo II MCUs targeted at automotive systems such as instrument clusters and Head-Up Displays (HUD). These devices have a 2D Graphics engine, Sound Processing, two Arm Cortex-M7 CPUs for primary processing, and a CM0+ CPU for peripheral and security processing. These devices contain embedded peripherals supporting CAN FD, LIN, Clock Extension Peripheral Interface (CXPI), and Gigabit Ethernet. They are manufactured using an advanced 40-nm process. CYT4D incorporates Cypress' low-power flash memory,

Feature Set

multiple high-performance analog and digital peripherals, and enables the creation of a secure computing platform. **Figure 3** shows the block diagram of CYT4DN.

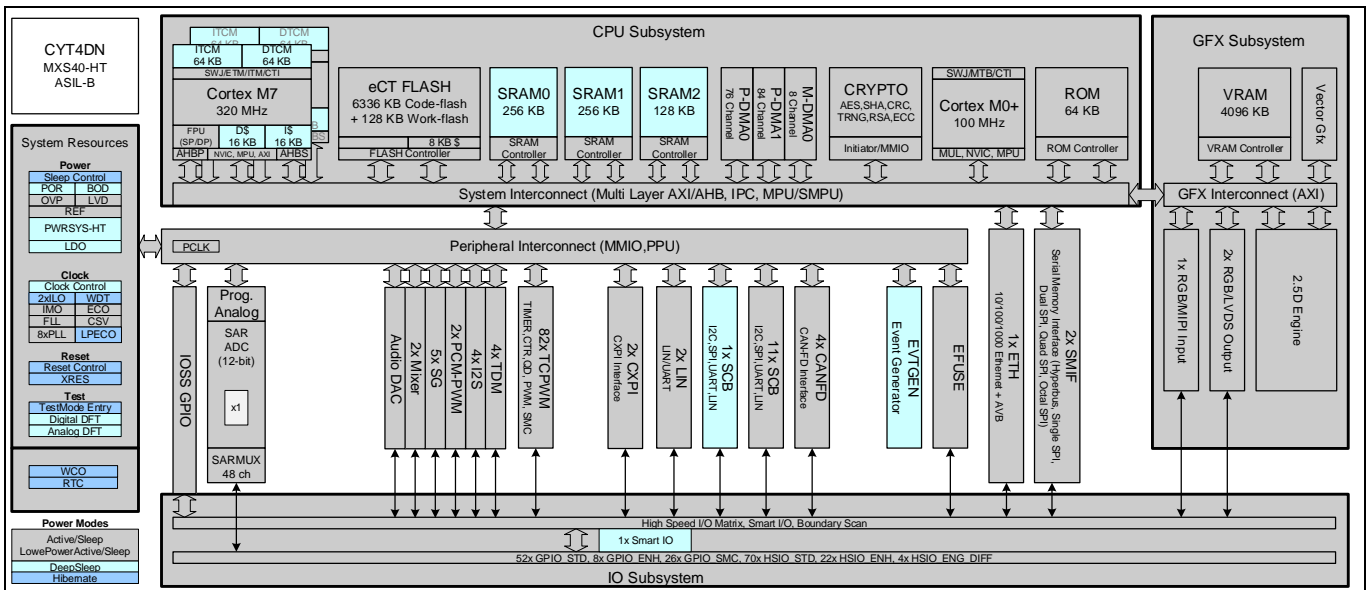

Figure 3 Block Diagram of CYT4DN

2.3.1 Function Summary

- Graphics subsystem
 - Supports 2D and 2.5D (perspective warping, 3D effects) graphics rendering
 - Up to 24-bit color resolution (RGB)
 - 4096 KB embedded video RAM memory (VRAM)
 - Up to two video output interfaces supporting two displays, including:
 - One parallel RGB (max display size: 1600 × 600)
 - Two FPD-link/LVDS single (max display size: 1920 × 720)
 - One FPD-link/LVDS dual (max display size is 2880 × 1080)
 - One Capture engine for video input processing for ITU 656 or parallel RGB/YUV input, which can either of the following:
 - RGB (maximum capture size 1600 × 600)
 - Four-Lane MIPI CSI-2 interface for up to Wide-HD resolution video input (maximum capture size 1920 × 720, two lanes and 2880 × 1080, four lanes)
 - ITU656 (standard camera capture, up to 800 × 480)
- Sound subsystem
 - Supports four I²S interfaces based on NXP I²S bus specifications for connecting digital audio devices
 - Four TDM interfaces
 - Two pulse-code modulation-pulse width modulation (PCM-PWM) interfaces
 - Up to five sound generator (SG) interfaces
 - Two PCM Audio stream mixers with five input streams
 - One audio digital-to-analog converter (DAC)

Feature Set

- Dual-CPU subsystem
 - Two 320-MHz 32-bit Arm Cortex-M7 CPUs, each with single-cycle multiply, and single/double-precision floating point unit (FPU) and memory protection units (MPUs)
 - 100-MHz 32-bit CM0+ with MPU
- Integrated memories
 - Up to 6336 KB (6080 KB + 256 KB) of code flash along with up to 128 KB (96 KB + 324 KB) of work flash
 - Read-While-Write (RWW) allows updating the code flash/work flash while executing from code flash
 - Support for single and dual bank mode
- CAN FD
 - Increased data rate compared to classic CAN, only limited by physical layer topology and devices (transceivers)
 - Supports up to 8 Mbps
 - Supports up to four CAN FD channels
 - Conforms to ISO11898-1:2015 standard
- Ethernet MAC
 - 1 ch × 10/100/1000
- SMIF (Serial Memory Interface)
 - HyperBus, Single SPI, Dual SPI, Quad SPI, Octal SPI
- Crypto engine
- Functional safety for ASIL-B
- Single power supply: $V_{DD} = 2.7\text{ V to }5.5\text{ V}$ (Up to 300 mA) / Dual power supply: $V_{DD} = 2.7\text{ V to }5.5\text{ V}$ and $V_{CCD} = 1.15\text{ V}$ (Exceeds 300 mA)
- Debug interface
- JTAG controller and interface compliant IEEE-1149.1-2001, SWD protocol
 - Flash programming on JTAG I/F and SWD
- Compatible with industry-standard tools
 - GHS/MULTI or IAR EWARM for code development and debugging
 - Supports Arm Embedded Trace Macrocell (ETM) Trace for Cortex-M7 processor
- Package lineup: BGA-500

2.4 Other Series

For the block diagram and function summary of other series, see the [device datasheet](#).

Development Environment and Tools

3 Development Environment and Tools

3.1 Evaluation Board

CYTVII-B-E-1M/CYTVII-B-8M/CYTVII-C-2D-6M Evaluation Kit is used by combining two boards. The CPU board (CYTVII-B-E-1M-xxx-CPU/CYTII-B-H-xxx-CPU) is meant to plug into the base board (CYTVII-B-E-BB). The CYTVII-C-2D-6M-xxx-CPU board is used standalone. Together with the base board, the CPU board provides access to all peripherals, resulting in a fully featured evaluation platform. CYTVII-B-E-1M-xxx-CPU/CYTII-B-H-8M-xxx-CPU/CYTVII-C-2D-6M-xxx-CPU has Cortex Debug, Cortex Debug+ETM, Arm Standard JTAG, and Arm Mictor-38 connectors for the debug interface. The evaluation board can be used for evaluation of device performance and development of software. For more information on board details, see the evaluation board user guide.

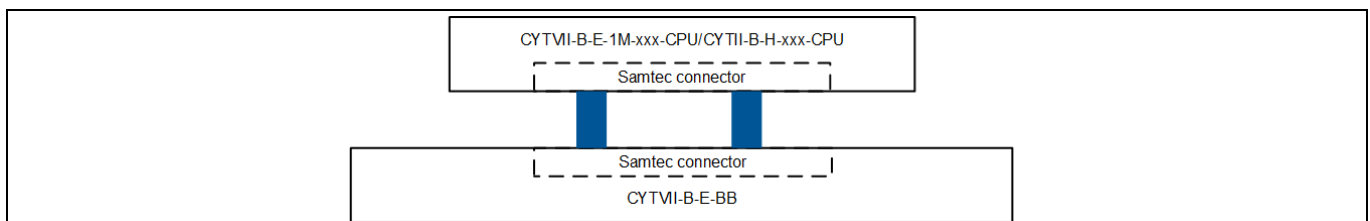

Figure 4 Evaluation Board

Table 1 CPU Board Part Number

Board	Part Number
	CYT2B7/B9 Series
CYTVII-B-E-1M -176-CPU	176-pin LQFP
CYTVII-B-E-1M -144-CPU	144-pin LQFP
CYTVII-B-E-1M -100-CPU	100-pin LQFP
CYTVII-B-E-1M -80-CPU	80-pin LQFP
CYTVII-B-E-1M -64-CPU	64-pin LQFP
	CYT4B Series
CYTVII-B-H-8M -320-CPU	320-ball BGA
CYTVII-B-H-8M -272-CPU	272-ball BGA
CYTVII-B-H-8M-176-CPU	176-pin TEQFP
	CYT4D Series
CYTVII-C-2D-6M-500-CPU	500-ball BGA
CYTVII-C-2D-6M-327-CPU	327-ball BGA

3.1.1 Functions Available on the Base Board

Table 2 Resource List of CYTVII-B-E-BB

Components	Description	Availability
CAN FD	Connector (D-sub 9-pin) and Transceiver (TJA1057GT, 6 channels and TJA1145T/FDJ, 4 channels)	10 channels
LIN	Connector (D-sub 9-pin) and Transceiver (TJA1021T/20)	6 channels
I ² C	Pin header	8 channels

Development Environment and Tools

CXPI	Connector (D-sub 9-pin) and Transceiver (S6BT112A)	1 channel
ADC	Pin header	72 channels
FlexRay	Connector (D-sub 9-pin) and Transceiver (AS8221)	2 channels
Potentiometer	For controlling ADC. (Alps RK09K1130A8G)	1
User Buttons	User Controlled	5 buttons
User LEDs	Green LED	10 LEDs

3.1.2 Connection Diagram with Tools

The CYT2, CYT3, and CYT4 series MCUs have JTAG/SWD ports to connect with a debugging tool. The debug pin of SWD is shared with JTAG and is also shared with other functions, for example, TCPWM/SCB/LIN/CAN. For details, see the [datasheet](#). **Figure 5** shows an example of the basic connection diagram for CYT2, CYT3, and CYT4 series.

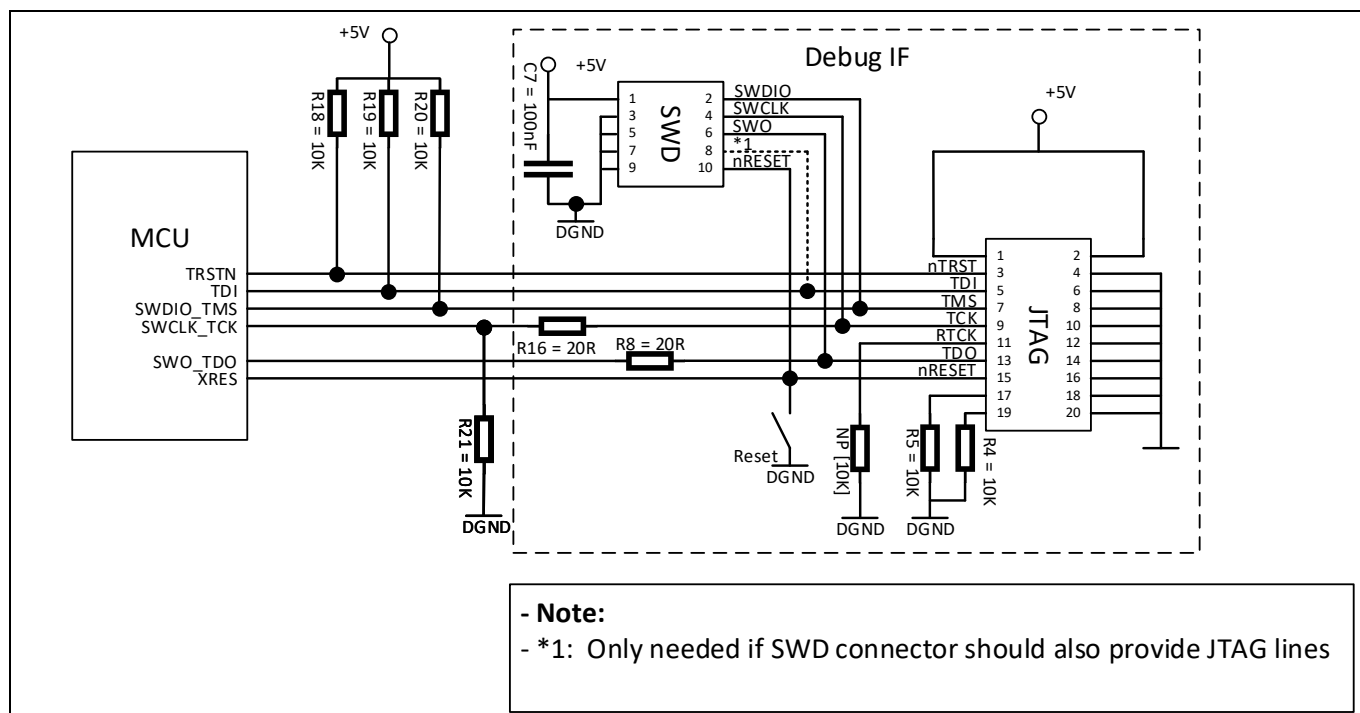

Figure 5 Basic Connection Diagram of CYT2, CYT3, CYT4 Series

Table 3 Cortex Debug + ETM Connector

Pin	Signal	Pin	Signal
1	VCC	2	SWDIO/TMS
3	GND	4	SWDCLK/TCK
5	GND	6	SWO/TDO/EXTa/TRACECTL
7	KEY	8	NC/EXTb/TDI
9	GNDDetect	10	nRESET
11	GND/TgtPwr+Cap	12	TRACECLK
13	GND/TgtPwr+Cap	14	TRACEDATA[0]
15	GND	16	TRACEDATA[1]

Development Environment and Tools

Code Listing 1

			drivers	
				canfd
				CAN FD API
				cy_canfd.c
				CAN FD source file
				cy_canfd.h
				CAN FD header file
				xxx
				xxx API
				cy_xxx.c
				xxx source file
				cy_xxx.h
				xxx header file
				mw
				button
				cy_button.c
				Button middleware source file
				cy_button.h
				Button middleware header file
				semihosting
				cy_semihosting.c
				Semihosting middleware source file
				cy_semihosting.h
				Semihosting middleware header file
				sw_timer
				cy_sw_tmr.c
				Software Timer middleware source file
				cy_sw_tmr.h
				Software Timer middleware header file
				flash
				cy_mw_flash.c
				Simplified Flash API source file
				cy_mw_flash.h
				Simplified Flash API header file
				startup
				ghs
				GHS
				startup_cm0plus.arm
				startup_cm4.arm
				startup_cm7.arm
				iar
				IAR
				startup_cm0plus.s
				startup_cm4.s
				startup_cm7.s
				startup.c
				C startup code
				startup_customize.h
				C startup code before main()
				tviiibelm
				TVII-B-E-1M folder
				hdr
				ip
				CANFD IP Register Definitions
				cyip_canfd.h
				CANFD IP definitions
				cyip_xxxxx.h
				xxxxx IP definitions
				:
				mcureg
				cyreg_canfd.h
				CANFD register definition header
				cyreg_xxxxx.h
				xxxxx register definition header

Development Environment and Tools

Code Listing 1

```

| | | | | :
| | | | | src
| | | | | drivers
| | | | | adc
| | | | | | cy_adc.c          ADC source file
| | | | | | cy_adc.h        ADC header file
| | | | | | cpu
| | | | | | flash
| | | | | | sysclk
| | | | | | sysfit
| | | | | examples
| | | | | | adc
| | | | | | canfd
| | | | | | :
| | | | | | system
| | | | | | | system_cyt2b7.h
| | | | | | | system_tviibelm_cm0plus.c
| | | | | | | system_tviibelm_cm4.c
| | | | | | cy_interrupt_map.c          System interrupt handlers
| | | | | | cy_interrupt_map_cm0plus.h System interrupt handlers CM0+ header file
| | | | | | cy_interrupt_map_cm4.h     System interrupt handlers CM4 header file
| | | | | | main_cm0plus.c             Main file for CM0+
| | | | | | main_cm4.c               Main file for CM4
| | | | | tools
| | | | | | ghs                      GHS MULTI workspaces
| | | | | | | _gpj
| | | | | | | | cym0plus.gpj
| | | | | | | | cm4.gpj
| | | | | | | | crypto_client.gpj
| | | | | | | | crypto_library.gpj
| | | | | | | | crypto_server.gpj
| | | | | | | | debugging.gpj
| | | | | | | | xxxx.gpj
| | | | | | | debugging              For debugging
| | | | | | | | tvii_debug.py
| | | | | | | | tviibelm.con
| | | | | | | | tviibelm.ghpcfg
| | | | | | | flash                  For Flash execution
| | | | | | | | cm0plus
| | | | | | | | cm4

```

Development Environment and Tools

Code Listing 1

					cm0plus_only.ghsmc	
					cm0plus_with_cm4.ghsmc	
					sram	For RAM execution
					cm0plus	
					cm4	
					cm0plus_only.ghsmc	
					cm0plus_with_cm4.ghsmc	
					iar	IAR workspaces
					debugging	
					flash	
					setting	
					sram	
					└-tviibe2m	TVII-B-E-2M folder
					└-tviibe4m	TVII-B-E-4M folder
					└-tviibe512k	TVII-B-E-512KB folder
					└-tviibh4m	TVII-B-H-4M folder
					└-tviibh8m	TVII-B-H-8M folder
					└-tviic2d4m	TVII-C-2D-4M folder
					└-tviic2d6m	TVII-C-2D-6M folder

3.2.2 CPU (CM0+ and CM4) Startup Sequence for CYT2B Series

The following steps describe the startup sequence:

1. System reset (@0x0000 0000).
 2. CM0+ executes ROM boot (@0x0000 0004).
 - a) Applies trims.
 - b) Applies debug access port (DAP) access restrictions and system protection from eFuse and supervisory flash.
 - c) Authenticates FlashBoot (only in SECURE life-cycle stage) and transfers control to it.
3. CM0+ executes FlashBoot (from supervisory flash @0x1700 2000).
 - a) Configures debug pins per the SWD/JTAG spec.
4. CM0+ starts execution of the user application.
 - a) Moves the CM0+ vector table to the SRAM (updates CM0+ vector table base).
 - b) Sets CM4_VECTOR_TABLE_BASE (@0x4020 0200) to the location of the CM4 vector table mentioned in flash (specified in the CM4 linker definition file).
 - c) Enables power for CM4.
 - d) Continues execution of the CM0+ user application.
5. CM4 executes ROM boot (@0x0000 0004).
 - a) CM4 branches to its reset handler.
 - b) Continues execution of the CM4 user application.

Development Environment and Tools

3.2.3 CPU (CM0+ and CM7) Startup Sequence for CYT4B/CYT4D Series

The following steps describe the startup sequence:

1. System reset (@0x0000 0000).
2. CM0+ executes ROM boot (@0x0000 0004).
 - a) Applies trims.
 - b) Applies debug access port (DAP) access restrictions and system protection from eFuse and supervisory flash.
 - c) Authenticates FlashBoot (only in SECURE life-cycle stage) and transfers control to it.
3. CM0+ executes FlashBoot (from supervisory flash @0x1700 2000).
 - a) Configures debug pins based on the SWD/JTAG spec.
4. CM0+ starts execution of the user application.
 - a) Moves the CM0+ vector table to the SRAM (updates the CM0+ vector table base).
 - b) Sets up wait states for different memory subsystems.
 - c) Sets up root clocks and enables core external supply (PMIC), graphics subsystem, and so on.
 - d) Sets clocks for CM7_0 (CLK_HF1) and CM7_1 (CLK_HF1).
 - e) Sets CM7_0 (CM7_0_VECTOR_TABLE_BASE @0x4020 0200) and CM7_1 (CM7_1_VECTOR_TABLE_BASE @0x4020 0600) vector tables to the respective locations and mentioned in flash (specified in the linker definition file).
 - f) Enables power for both the CPU cores CM7_0 and CM7_1.
 - g) Disables CPU_WAIT.
 - h) Continues execution of the CM0+ user application.
5. CM7_0 and/or CM7_1 executes directly from either code flash or SRAM.
 - a) CM7_0/CM7_1 branches to its reset handler.
 - b) Continues execution of the CM7_0/CM7_1 user application.

3.2.4 Startup Flow Example

The startup process is executed after the boot process completes. In the boot process, according to the lifecycle stage, protection status and debug access restriction setting are mainly performed, and application authentication is performed. In the startup process, initial settings necessary for program execution such as stack setting, RAM initialization, and clock settings are completed, and then execution jumps to the main routine. CM0+ executes the boot code after reset. CM4/CM7 will be activated after the boot process by the CM0+ user application.

Development Environment and Tools

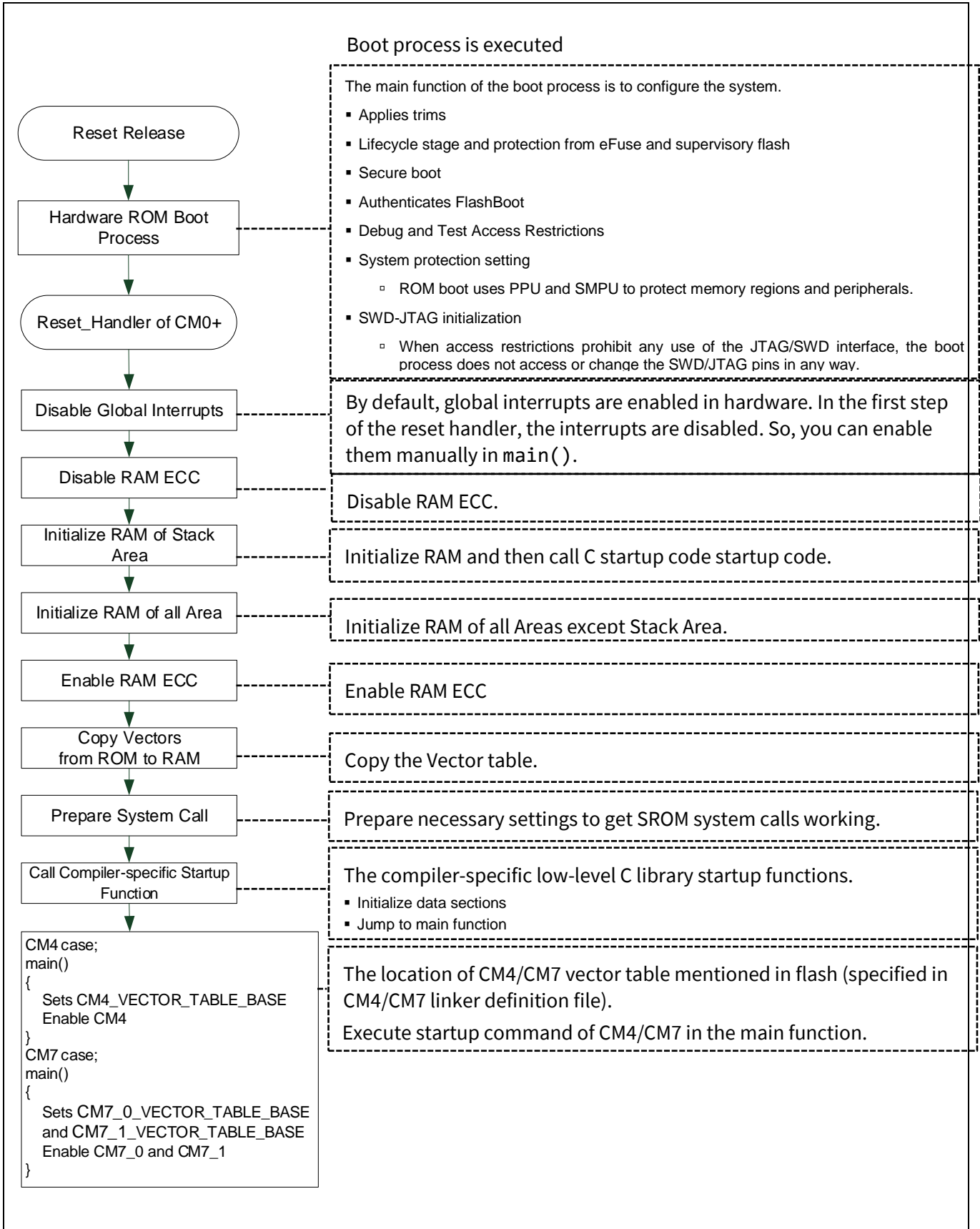

Development Environment and Tools

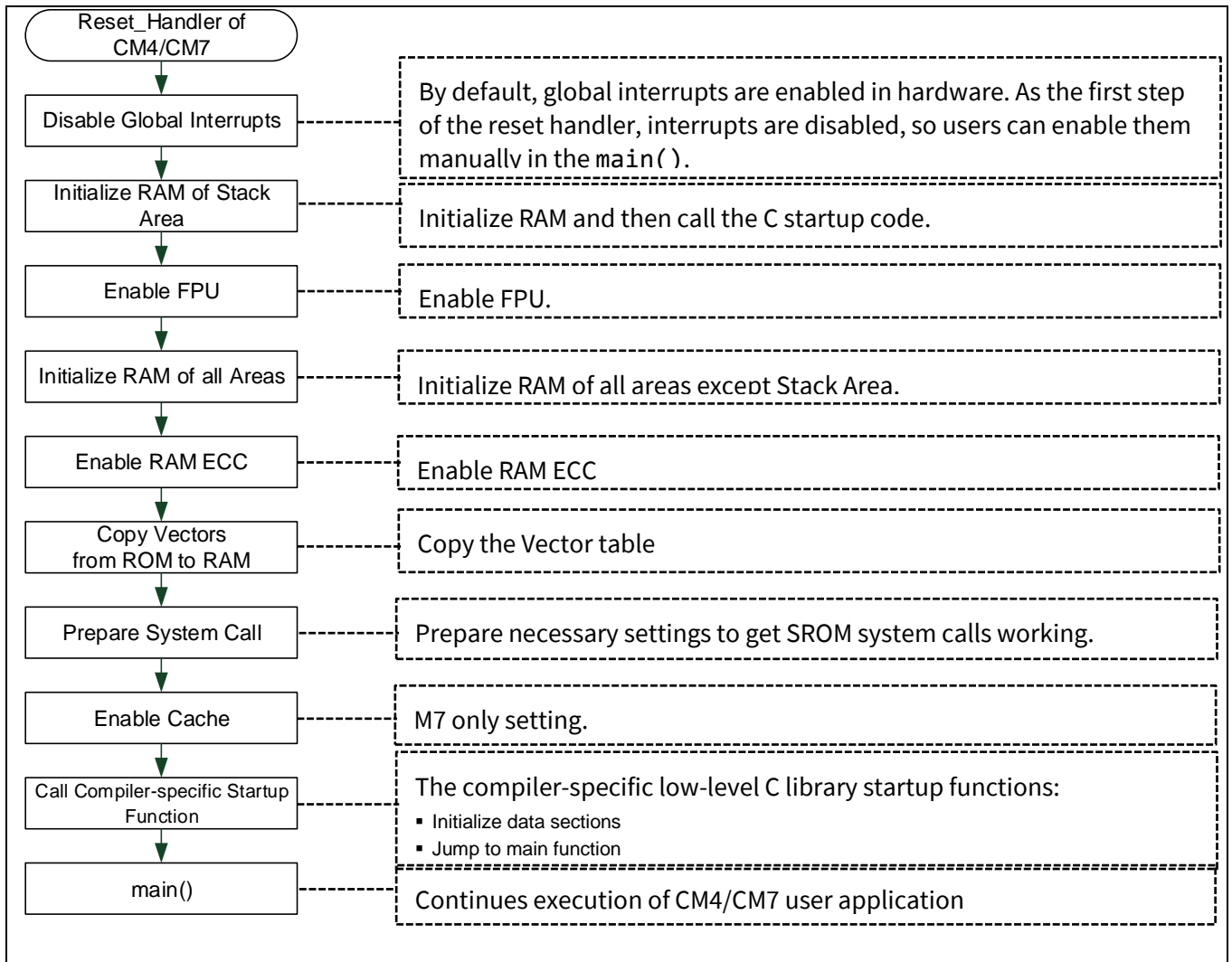

Figure 6 Device Startup Flow

Development Environment and Tools

3.2.5 Sample Code

Code Listing 2 Sample Code for CM0+ Startup

```

;*****
;* Start-up Code
;*****

    .weak Reset_Handler
    .section ".text", "ax"
    .thumb

Reset_Handler:
_start:

; Disable global interrupts
    CPSID    I

; Update Vector Table Offset Register with address of user ROM table
; (will be updated later to user RAM table address in C startup code)
    LDR    r0, =__vector_table
    LDR    r1, =VTOR
    STR    r0, [r1]
    DSB

; CM0+ bus width is 32-bit, but SRAM is built with 64-bit based ECC on Traveo II parts with
CM7 core
; Set CPUSS->RAMx_CTL0.ECC_CHECK_DIS bits to avoid causing unintentional ECC faults during
startup while SRAM ECC has not been initialized yet
; Generic code can be used, even if RAMx_CTL0 (x > 0) registers are not implemented in a
device
; or if no ECC_CHECK_DIS bits are available in the registers in case of m4cpuss with 32-bit
ECC SRAM
    MOVS    r0, #1
    LSLS    r0, r0, #19
    LDR    r1, =CPUSS_RAM0_CTL0
    LDR    r2, [r1]
    ORRS    r2, r0
    STR    r2, [r1]
    LDR    r1, =CPUSS_RAM1_CTL0
    LDR    r2, [r1]
    ORRS    r2, r0
    STR    r2, [r1]
    LDR    r1, =CPUSS_RAM2_CTL0
    LDR    r2, [r1]
    ORRS    r2, r0
    STR    r2, [r1]

; Initialize ECC of startup stack (needed for local variables in C startup code) by
processing 8 bytes per loop iteration,

```

Development Environment and Tools

Code Listing 2 Sample Code for CM0+ Startup

```

; because the ECC initialization feature uses this generic granularity that will cover any
memory (SRAM/TCM) in any TVII device
; Prerequisite: Stack Pointer (SP) has not been modified (from the vector table init value)
by above code (otherwise code must be adapted)
    MOVS r0, #0 ; clear value
    MOVS r1, #0 ; clear value
    LDR r2, Cy_u32StartupStackStartAddress
startup_stack_ecc_init_loop:
    STM r2!, {r0, r1}
    CMP r2, sp
    BNE startup_stack_ecc_init_loop

; Call C startup code (no ANSI C context established yet!)
    LDR r7, =Startup_Init
    BLX r7

; Call system library
    LDR r5, pool_myaddr
    SUB r5, r5, 1 ; unset the low order bit
myaddr:
    MOV r2, pc
    SUB r5, r2, r5 ; Now r5 contains picbase

    MOV r0, 0
    MOV fp, r0 ;* No previous frame *

    LDR r0, pool_baseptrs
    ADD r0, r0, r5 ;* Add in picbase *
    MOV r1, 0 ;* Clear argc reg *
    MOV r2, 0 ;* Clear argv reg *
    MOV r3, 0 ;* Clear envp reg *
    MOV r4, 0 ;* Clear global regs *
    MOV r5, 0
    MOV r6, 0

    LDR r7, =__ghs_ind_crt0
    BLX r7

; Note: Control flow does not necessarily return here.
; On some tool-chains (e.g. IAR) control flow will never return from
; the system library.
Cy_Main_Exited:
    B Cy_Main_Exited

    .endif _start

```

Code Listing 3 Sample Code for CM0+ Main Function

```
int main(void)
{
    __enable_irq(); /* Enable global interrupts. */
    /* Enable CM4. CY_CORTEX_M4_APPL_ADDR must be updated if CM4 memory layout is changed.
    */
    Cy_SysEnableCM4(CY_CORTEX_M4_APPL_ADDR);

    /* Place your initialization/startup code here (e.g. MyInst_Start()) */
    Cy_GPIO_Pin_Init(USER_LED0_PORT, USER_LED0_PIN, &user_led0_port_pin_cfg);

    for(;;)
    {
        DELAY(150000);
        Cy_GPIO_Inv(USER_LED0_PORT, USER_LED0_PIN);
    }
}
```

Code Listing 4 Sample Code for CM4 Startup

```
*****
; * Start-up Code
;*****
    .weak Reset_Handler
    .section ".text", "ax"
    .thumb2

Reset_Handler:
_start:

; Disable global interrupts
    CPSID    I

; Update Vector Table Offset Register with address of user ROM table
; (will be updated later to user RAM table address in C startup code)
    LDR    r0, =__vector_table
    LDR    r1, =VTOR
    STR    r0, [r1]
    DSB

; Initialize ECC of startup stack (needed for local variables in C startup code) by
; processing 8 bytes per loop iteration,
```

Development Environment and Tools

Code Listing 4 Sample Code for CM4 Startup

```

; because the ECC initialization feature uses this generic granularity that will cover any
memory (SRAM/TCM) in any TVII device
; Prerequisite: Stack Pointer (SP) has not been modified (from the vector table init value)
by above code (otherwise code must be adapted)
    MOVS r0, #0 ; clear value
    MOVS r1, #0 ; clear value
    LDR  r2, Cy_u32StartupStackStartAddress
startup_stack_ecc_init_loop:
    STRD r0, r1, [r2], #8
    CMP  r2, sp
    BNE  startup_stack_ecc_init_loop

; Call C startup code (no ANSI C context established yet!)
    LDR  r7, =Startup_Init
    BLX  r7

; Call system library
    LDR  r5, pool_myaddr
    SUB   r5, r5, 1 ; unset the low order bit
myaddr:
    MOV  r2, pc
    SUB   r5, r2, r5 ; Now r5 contains picbase

    MOV  r0, 0
    MOV  fp, r0 ;* No previous frame *

    LDR  r0, pool_baseptrs
    ADD  r0, r0, r5 ;* Add in picbase *
    MOV  r1, 0 ;* Clear argc reg *
    MOV  r2, 0 ;* Clear argv reg *
    MOV  r3, 0 ;* Clear envp reg *
    MOV  r4, 0 ;* Clear global regs *
    MOV  r5, 0
    MOV  r6, 0

    LDR  r7, =__ghs_ind_crt0
    BLX  r7

; Note: Control flow does not necessarily return here.
; On some tool-chains (e.g. IAR) control flow will never return from
; the system library.
Cy_Main_Exited:
    B    Cy_Main_Exited

    .endif _start

```

Code Listing 5 Sample Code for CM7 Startup

```

;*****
;* Start-up Code
;*****

    .weak Reset_Handler
    .section ".text", "ax"
    .thumb2

Reset_Handler:
_start:

; Disable global interrupts
    CPSID    I

; Update Vector Table Offset Register with address of user ROM table
; (will be updated later to user RAM table address in C startup code)
    LDR    r0, =__vector_table
    LDR    r1, =VTOR
    STR    r0, [r1]
    DSB

; Allow write access to Vector Table Offset Register and ITCM/DTCM configuration register
(CPUSS_CM7_X_CTL.PPB_LOCK[3] and CPUSS_CM7_X_CTL.PPB_LOCK[1:0])
    LDR    r1, =CPUSS_IDENTITY        ; first check master identity (CM7_0 or CM7_1?)
    LDR    r0, [r1]
    LSR    r0, r0, #8
    AND    r0, r0, #0xf
    CMP    r0, #MASTER_ID_CM7_0
    ITE    EQ                                ; load address of corresponding CPUSS_CM7_x_CTL
register
    LDREQ  r1, =CPUSS_CM7_0_CTL
    LDRNE  r1, =CPUSS_CM7_1_CTL
    LDR    r0, [r1]
    BIC    r0, r0, #0xb
    STR    r0, [r1]
    DSB

; Enable ITCM and DTCM
    LDR    r1, =ITCMCR
    LDR    r0, [r1]
    ORR    r0, r0, #0x7 ; Set ITCMCR.EN, .RMW and .RETEN fields
    STR    r0, [r1]

    LDR    r1, =DTCMCR
    LDR    r0, [r1]

```

Development Environment and Tools

Code Listing 5 Sample Code for CM7 Startup

```

    ORR    r0, r0, #0x7 ; Set DTCMCR.EN, .RMW and .RETEN fields
    STR    r0, [r1]

    DSB
    ISB

; Initialize ECC of startup stack (needed for local variables in C startup code) by
; processing 8 bytes per loop iteration,
; because the ECC initialization feature uses this generic granularity that will cover any
; memory (SRAM/TCM) in any TVII device
; Prerequisite: Stack Pointer (SP) has not been modified (from the vector table init value)
; by above code (otherwise code must be adapted)
    MOVS  r0, #0 ; clear value
    MOVS  r1, #0 ; clear value
    LDR   r2, Cy_u32StartupStackStartAddress
startup_stack_ecc_init_loop:
    STRD  r0, r1, [r2], #8
    CMP   r2, sp
    BNE  startup_stack_ecc_init_loop

; Call C startup code (no ANSI C context established yet!)
    LDR   r7, =Startup_Init
    BLX  r7

; Call system library
    LDR   r5, pool_myaddr
    SUB   r5, r5, 1 ; unset the low order bit
myaddr:
    MOV   r2, pc
    SUB   r5, r2, r5 ; Now r5 contains picbase

    MOV   r0, 0
    MOV   fp, r0 ; * No previous frame *

    LDR   r0, pool_baseptrs
    ADD   r0, r0, r5 ; * Add in picbase *
    MOV   r1, 0 ; * Clear argc reg *
    MOV   r2, 0 ; * Clear argv reg *
    MOV   r3, 0 ; * Clear envp reg *
    MOV   r4, 0 ; * Clear global regs *
    MOV   r5, 0
    MOV   r6, 0

    LDR   r7, =__ghs_ind_crt0
    BLX  r7

```

Development Environment and Tools

Code Listing 5 Sample Code for CM7 Startup

```

; Note: Control flow does not necessarily return here.
; On some tool-chains (e.g. IAR) control flow will never return from
; the system library.
Cy_Main_Exited:
    B    Cy_Main_Exited

    .endf _start
    
```

3.3 Peripheral Drivers

Peripheral drivers are a set of firmware drivers that provide APIs for accessing hardware. These APIs perform initialization and control activities of each peripheral.

3.3.1 Peripheral Drivers List

Table 4 lists the peripheral drivers that Cypress provides for SDL.

Table 4 Peripheral Drivers List

No.	Module	Description	Traveo II Family		
			CYT2B	CYT3B/4B	CYT4D
1	ADC	Analog-to-Digital Converter	✓	✓	✓
2	Audioss	Sound Subsystem for I2S, DAC, Mixer, PWM, SG, TDM	-	-	✓
3	AXIDMA	M-DMA on AXI bus	-	-	✓
4	CANFD	CAN FD	✓	✓	✓
5	CPU	Enables core of CPU-specific features	✓	✓	✓
6	CRYPTO	Cryptography	✓	✓	✓
7	CXPI	Manages communication over the CXPI interface	✓	-	✓
8	DMA	M-DMA, P-DMA	✓	✓	✓
9	ETHERNET	Basic Ethernet driver supporting Automotive and Gigabit Ethernet PHY	-	✓	✓
10	EVTGEN	Event generator	✓	✓	✓
11	FLASH	Code Flash, Work Flash	✓	✓	✓
12	FLEXRAY	Manages FlexRay communication	-	✓	-
13	FPDLINK	FPD-Link or LVDS	-	-	✓
14	GPIO	GPIO	✓	✓	✓
15	GFX_ENV	Graphics Environment Setup	-	-	✓
16	I ² S	Manage Inter-IC Sound. I2S is used to send digital audio streaming data to external I2S devices, such as audio codecs or simple DACs. It can also receive digital audio streaming data.	-	✓	-

Development Environment and Tools

No.	Module	Description	Traveo II Family		
			CYT2B	CYT3B/4B	CYT4D
17	IPC	Inter-Processor Communication	✓	✓	✓
18	LIN	Local Interconnect Network	✓	✓	✓
19	LVD	Provides LVD capabilities	✓	✓	✓
20	MCWDT	Multi-Counter Watchdog Timers	✓	✓	✓
21	MIPICSI2	Video Input	-	-	✓
22	MPU	Memory Protection Unit	✓	✓	✓
23	PROT	Protection Unit	✓	✓	✓
24	SCB	Serial Communication Block (SCB) - EZI2C, SCB - I2C, SCB - SPI, SCB - UART	✓	✓	✓
25	SD_HOST	Manages SD and eMMC devices	-	✓	-
26	SMART IO	Configure and access the Smart I/O hardware present between the GPIOs (pins) and HSIOMs (pin muxes) on select device ports. It can be used to perform simple logic operations on peripheral and GPIO signals at the GPIO port.	✓	✓	✓
27	SMIF	SPI-based communication interface for interfacing external memory devices to TVII. The SMIF supports Octal-SPI, Dual Quad-SPI, Quad-SPI, DSPI, and SPI. This interface also supports Hyper Bus interfaces like HyperRAM and HyperFlash devices.	-	✓	✓
28	SROM	Internal SROM driver	✓	✓	✓
29	SYSCLK	System Clock	-	✓	✓
30	SYSFLT	System Fault	✓	✓	✓
31	SYSINT	System Interrupt	✓	✓	✓
32	SYSLIB	System Library	✓	✓	✓
33	SYSPM	System Power Management	✓	✓	✓
34	SYSREGHC/ SYSPMIC	REGHC/PMIC Control and Status	-	✓	-
35	SYSRESET	Provides APIs for reading reset reason and clearing them	✓	✓	✓
36	SYSRTC	System Real-Time Clock	✓	✓	✓
37	SYSTICK	SysTick Timer	✓	✓	✓
38	SYSWDT	Free running Watchdog Timer	✓	✓	✓
39	TCPWM	Timer Counter PWM	✓	✓	✓
40	TRIGMUX	Trigger multiplexer	✓	✓	✓

Development Environment and Tools

3.4 Example Usage of SDL with GHS MULTI

3.4.1 Environment for SDL

This section describes the operation with CYT2B7 series SDL as an example.

SDL Operational Conditions:

- CPU: CYT2B7 series
- Target Board: Traveo II Evaluation board
- IDE: GHS MULTI V7.1.4 (compiler version 2017.1.4)
- Used API Module GPIO

3.4.2 Install GHS MULTI and SDL

Install GHS MULTI, set license, and set probe firmware in advance.

Install SDL according to SDL's instructions in advance.

3.4.3 Setup Debug Script and Configuration files

Using the scripts *tvii_detect.py* and *multi.irc*, in `C:\. . . \TVII_Sample_Driver_Library_revision\misc\tools\ghs\debugging\AppData_GHS`, you can execute the run process.

The process includes configuring probe, connecting target, and downloading the program into RAM. You will also be able to use detect the debugger script (D) button and load the program to the RAM (R) button.

Copy the files, *tvii_detect.py* and *multi.irc* to the `<%APPDATA%\GHS>` folder (that is, `C:\Users\<LOGIN_NAME>\AppData\Roaming\GHS`) on the PC.

If you are unable to find the *AppData* folder, follow these steps to display the hidden folders:

1. In Windows Explorer, go to the **View** tab.
2. Click **Options**.
3. In the Folder options dialog, go to the **View** tab.
4. Select Show hidden files, folders, and drives.
5. Click **OK**.

Development Environment and Tools

3.4.4 Setup with MULTI

1. Start the MULTI Project Manager and open the SDL project file:
`C:\...\TVII_Sample_Driver_Library_revision\tools\ghs\tviibe1m_template.gpj`

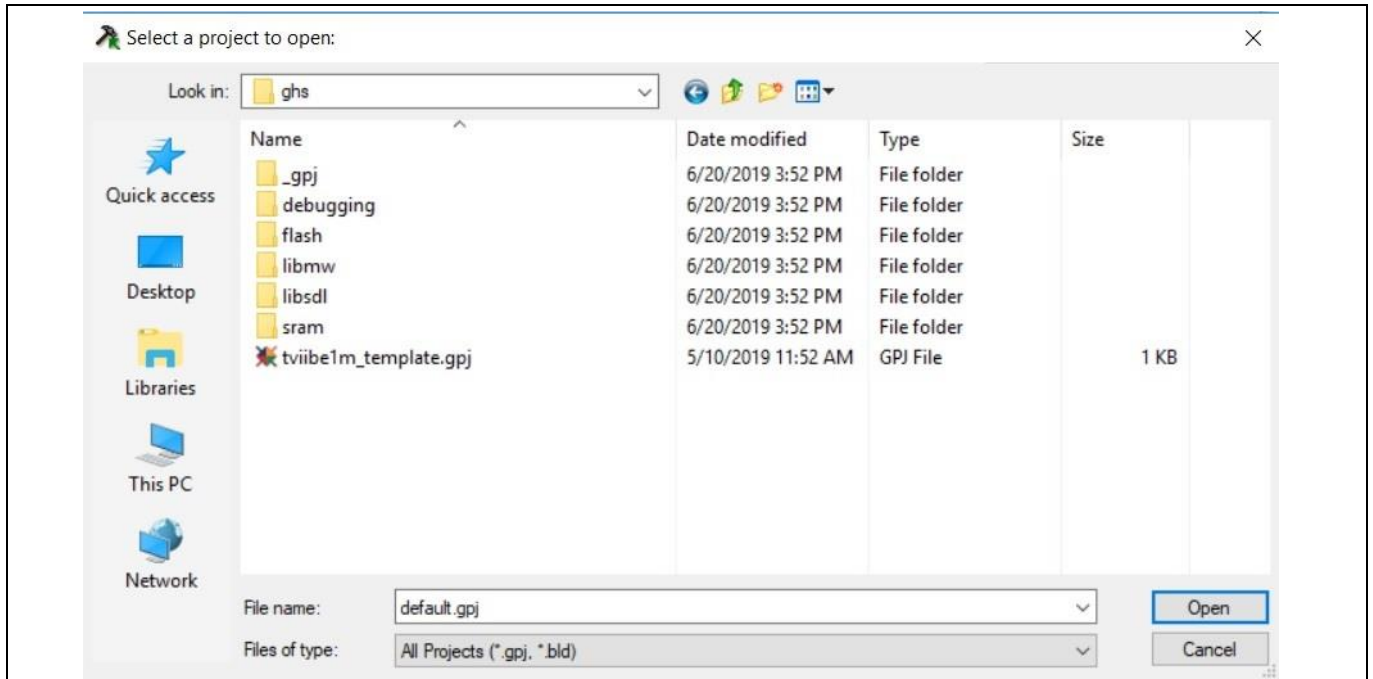

Figure 7 Select the SDL Project

Development Environment and Tools

- For the build, select *sram.gpj* and click the **hammer** icon as shown in **Figure 8**. The build starts and successful messages appear as shown in **Figure 9**.

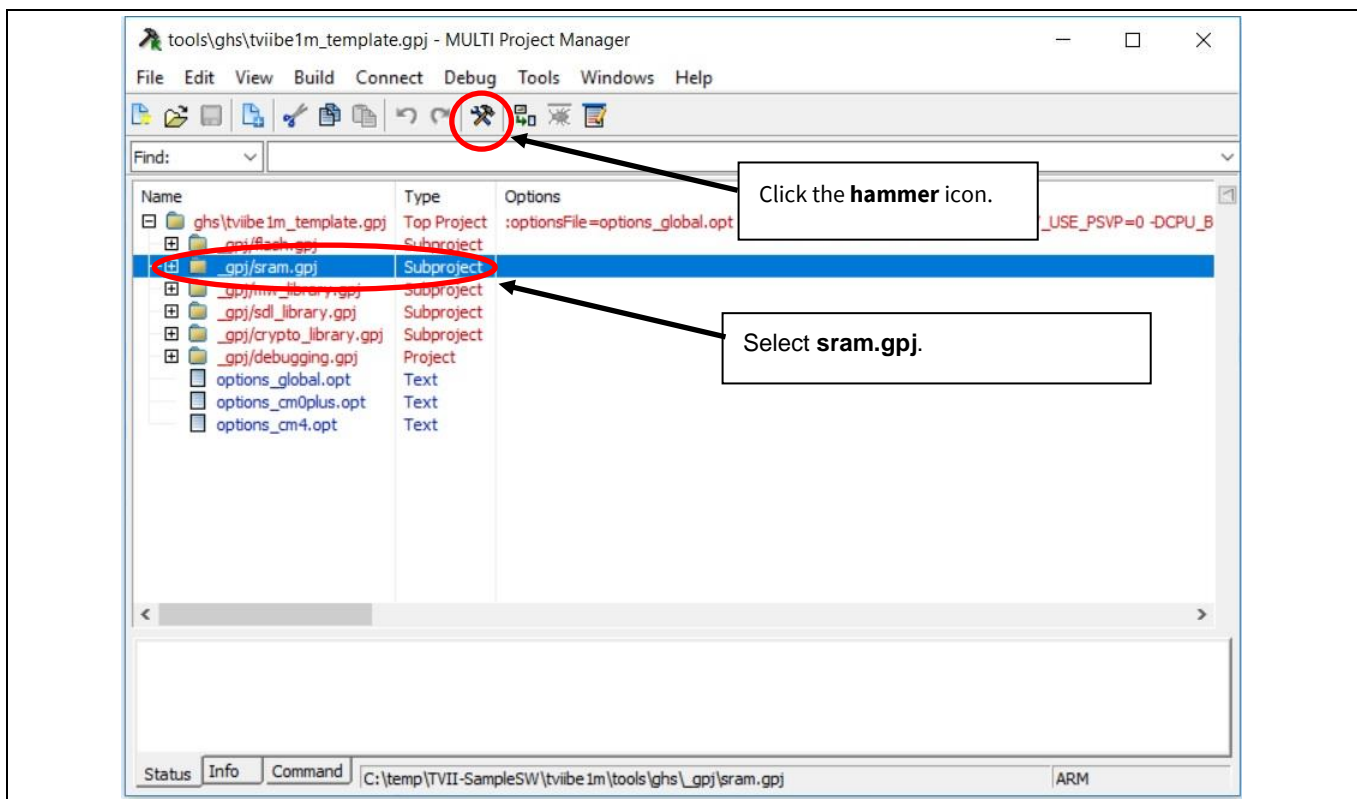

Figure 8 Build the Project of SDL Project

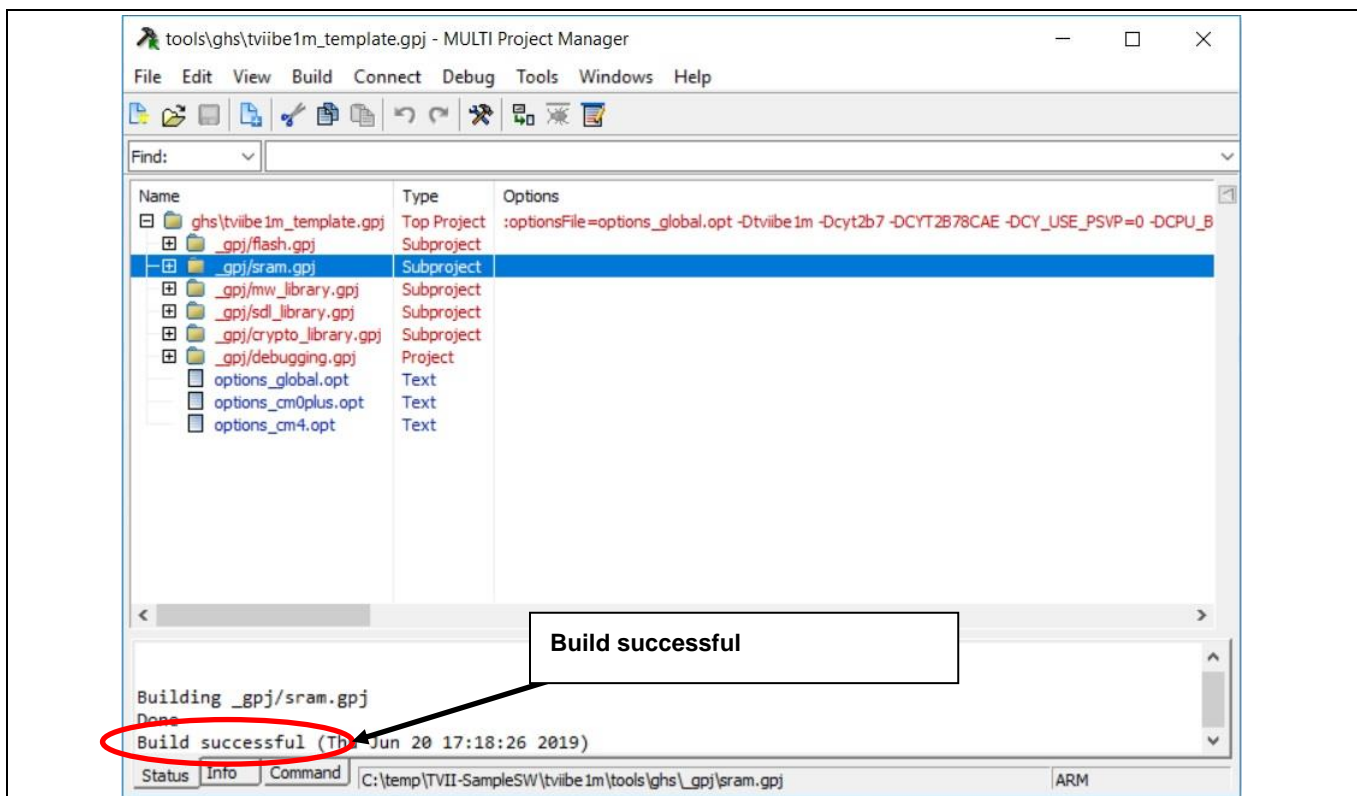

Figure 9 Build Successful of the Project of SDL Project

Development Environment and Tools

There are two debugging methods:

1. Debugging with Download on the RAM
2. Debugging with download on the Flash Memory

3.4.4.1 Debugging with Download on the RAM

1. For execution on the RAM, select `sram\cm0plus_with_cm4.gbsmc` and click the **Bug** icon as shown in **Figure 10**. Debugging of the program on the RAM begins.

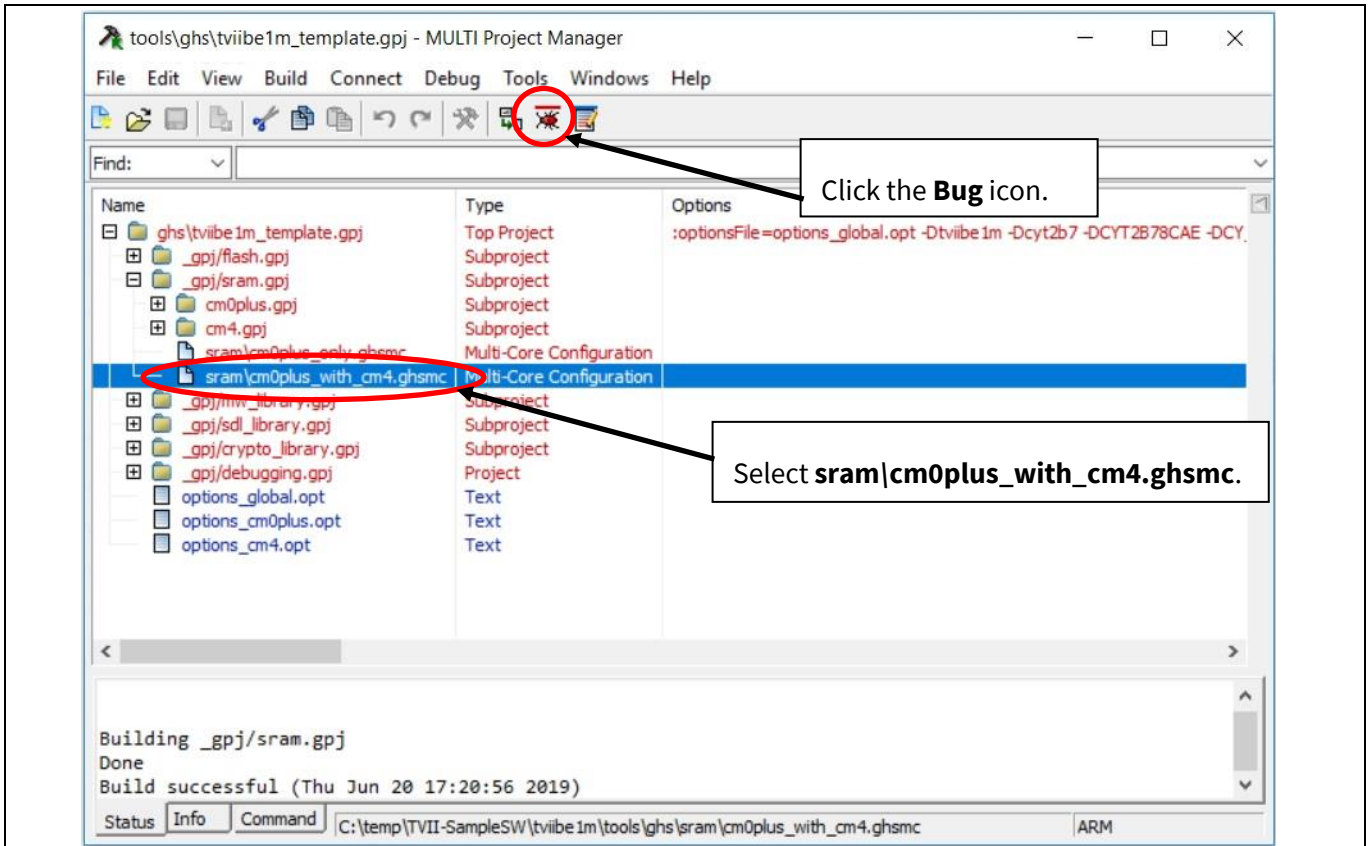

Figure 10 Debug the Project of SDL Project

Development Environment and Tools

- To enable the SDL project to detect the debugger script, click the **D** icon as shown in **Figure 11**.

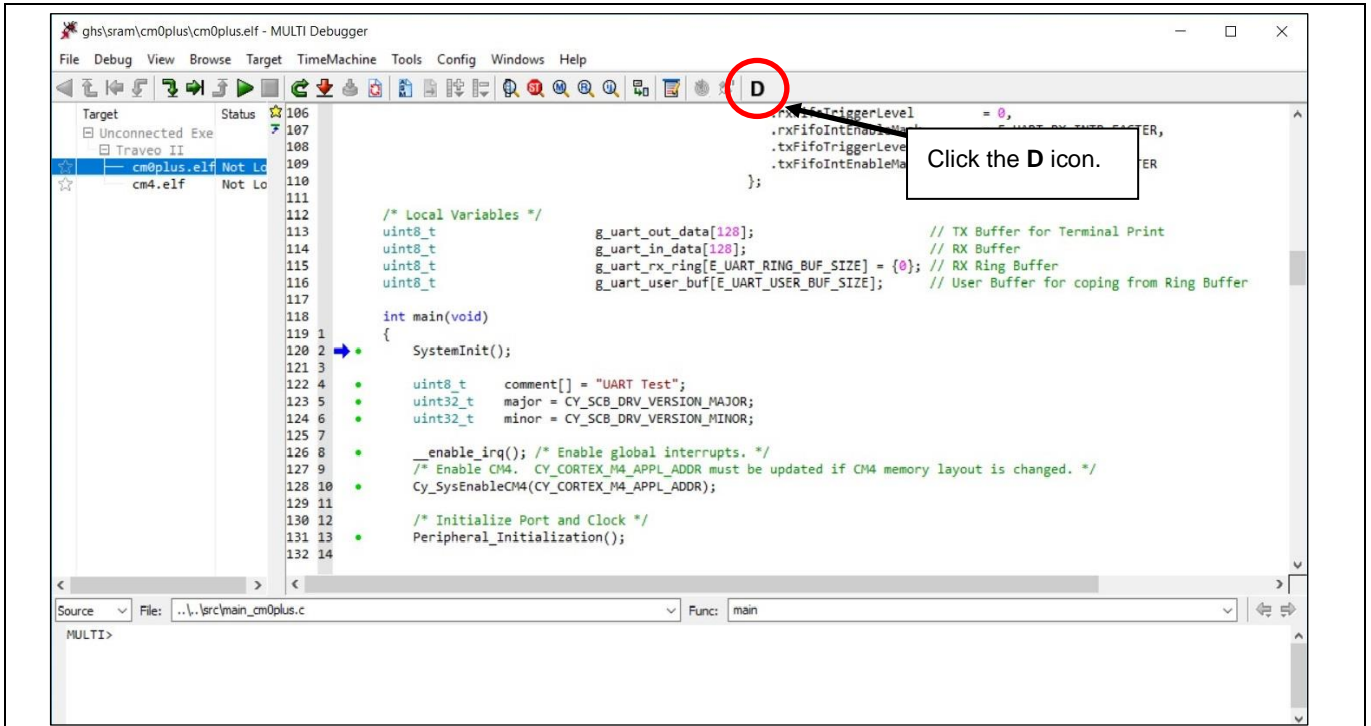

Figure 11 Debug the Project of SDL Project

- To load the program to the RAM, click the **R** icon as shown in **Figure 12**. Loading of the program to the RAM begins.

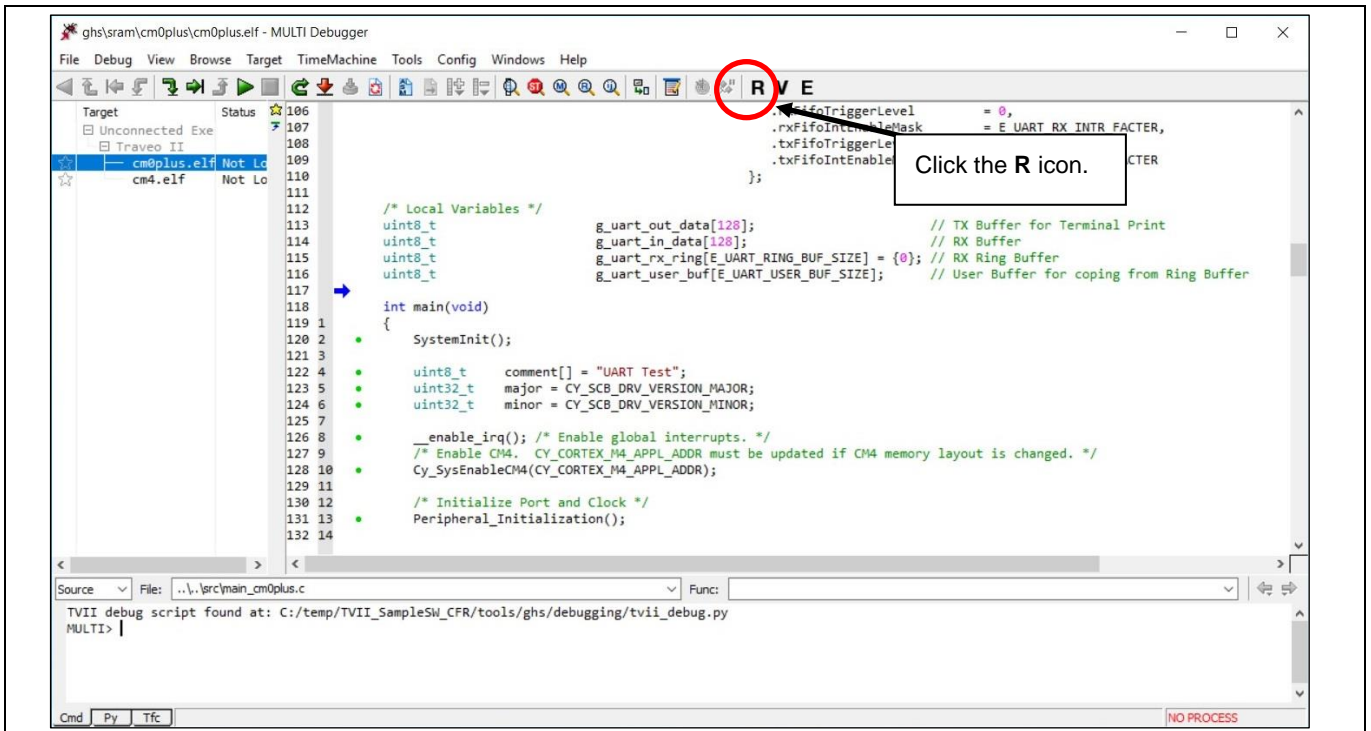

Figure 12 Load to RAM

Development Environment and Tools

4. Click the **run** icon as shown in **Figure 13**.

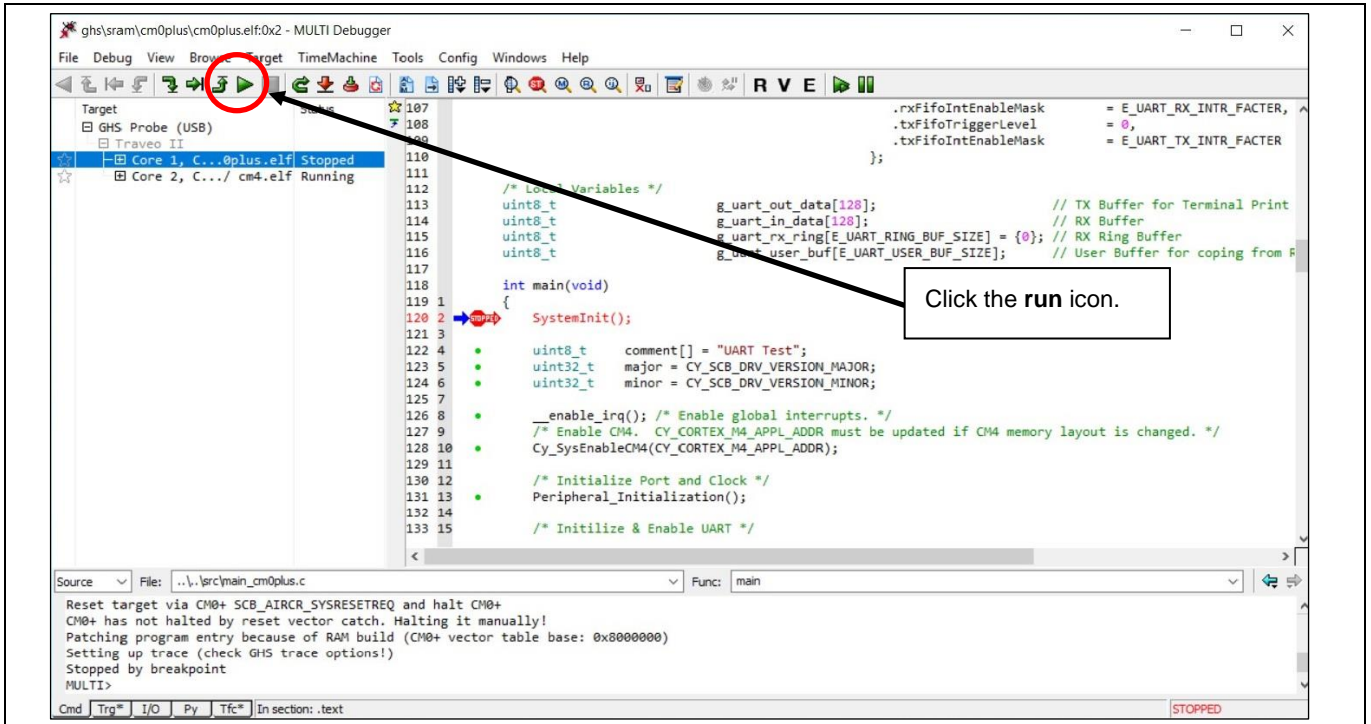

Figure 13 Execution on RAM

When these operations are performed, both CM0+ and CM4 programs will be in the program running state as shown in **Figure 14** and debugging will be possible. The board LED starts blinking.

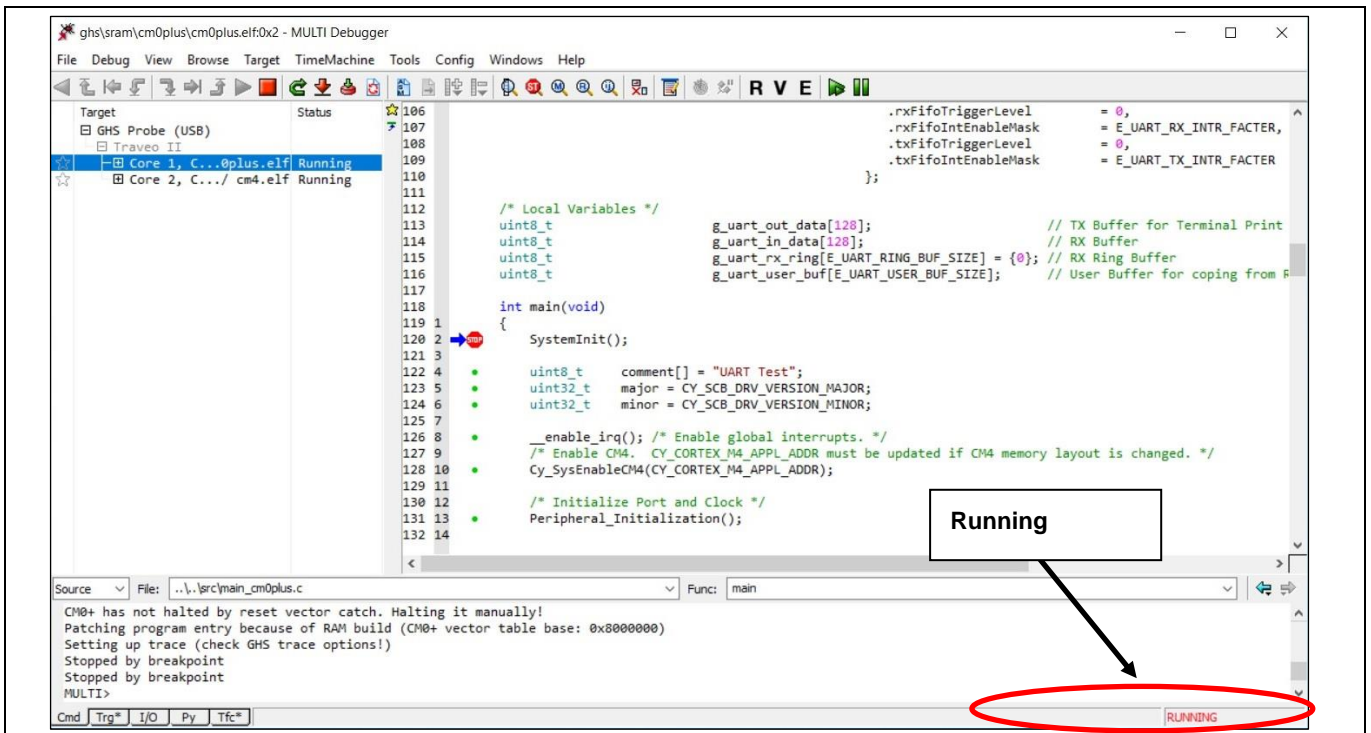

Figure 14 Running on the RAM

Development Environment and Tools

3.4.4.2 Debugging with download on the Flash Memory

1. For execution on the Flash memory, select `flash\cm0plus_with_cm4.ghsmc` and click the **Bug** icon as shown in **Figure 15**. Debugging of the program on the Flash memory begins.

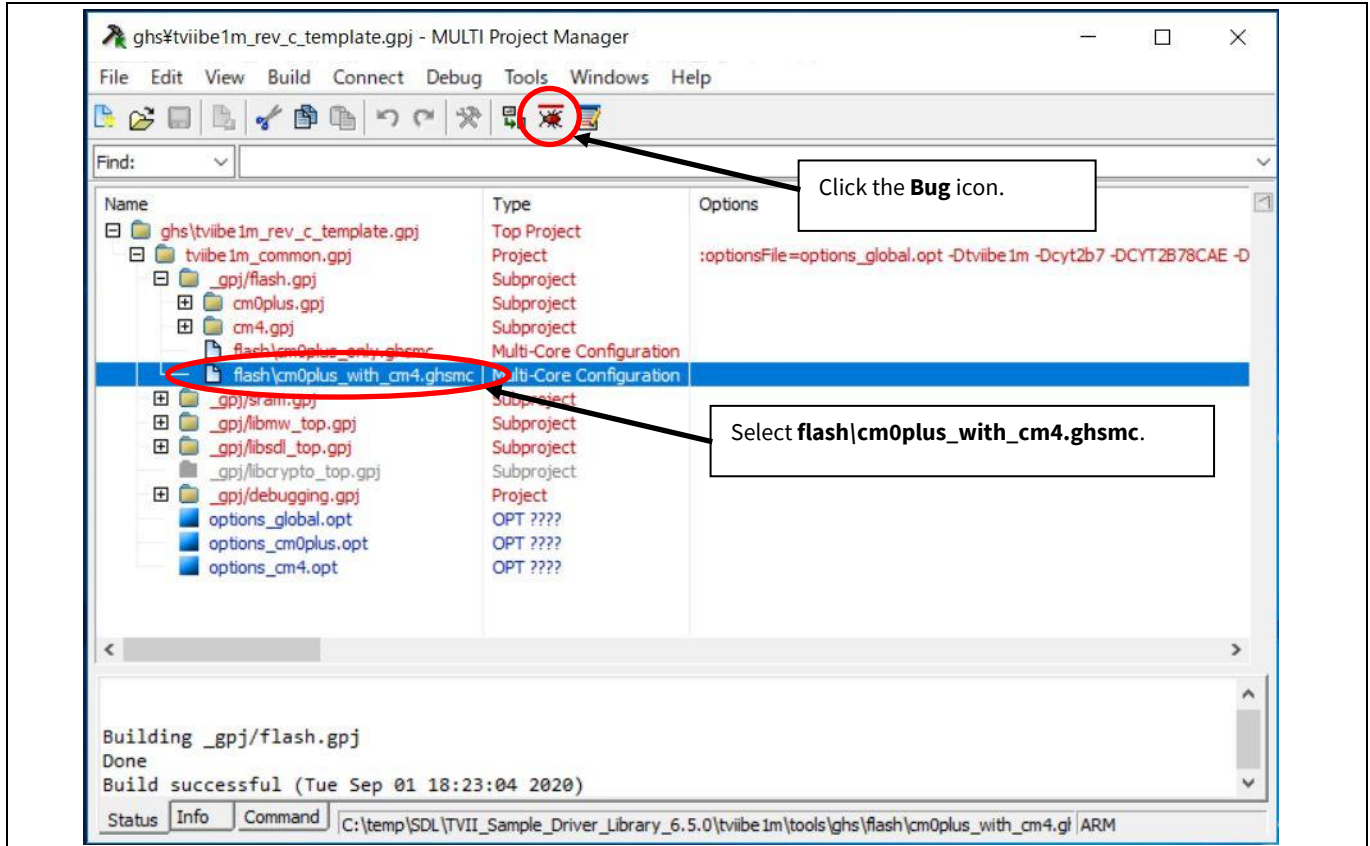

Figure 15 Debug the Project of SDL Project

Development Environment and Tools

2. To enable the SDL project to detect the debugger script, click the **D** icon as shown in **Figure 16**.

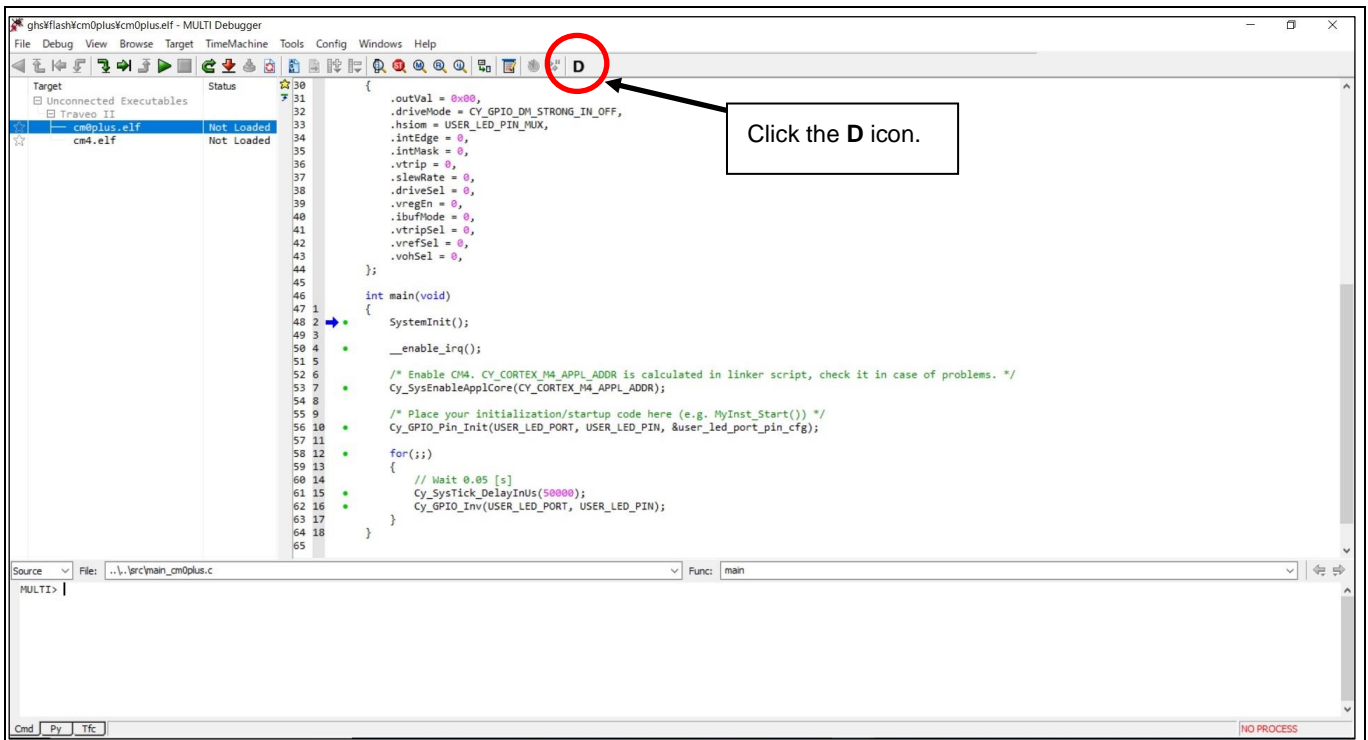

Figure 16 Debug the Project of SDL Project

3. To load the program to the Flash memory, click the **F** icon as shown in **Figure 17**. Loading of the program to the Flash memory begins.

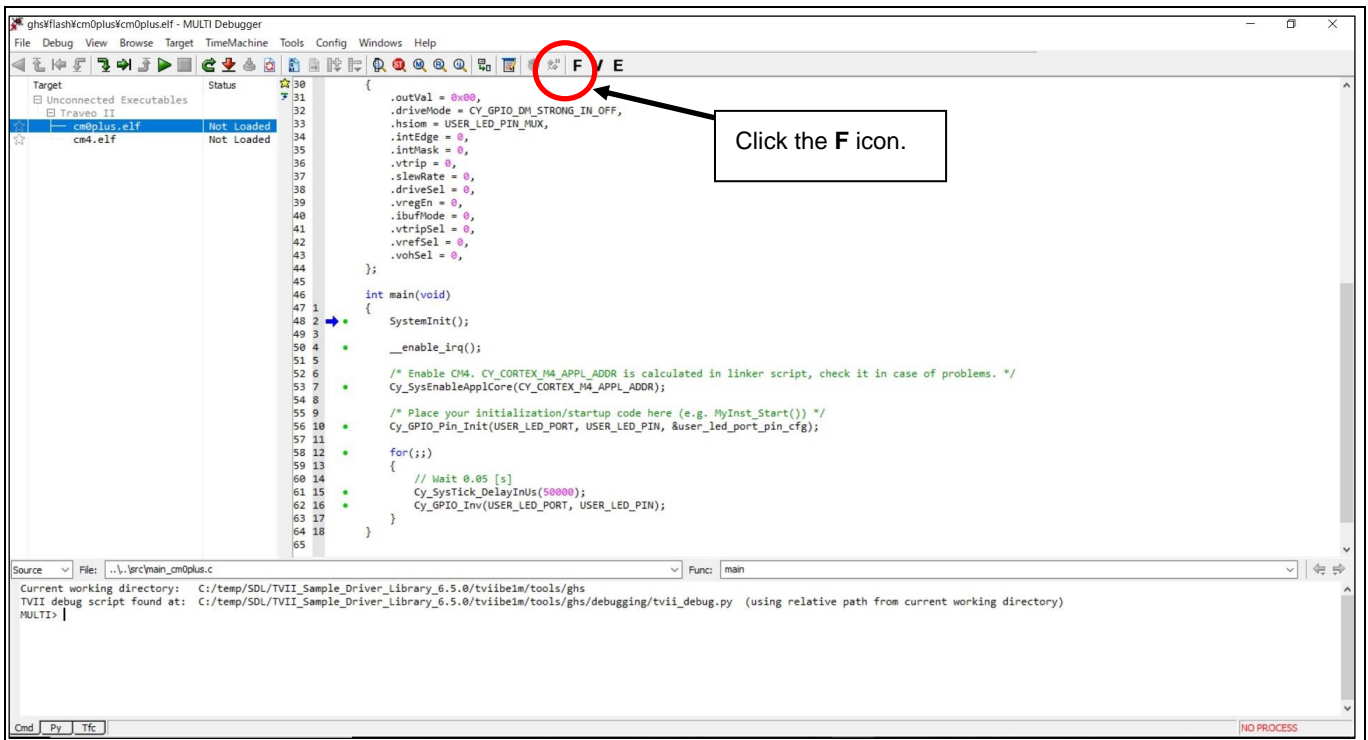

Figure 17 Load to Flash Memory

Getting Started with Traveo II Family MCUs

Development Environment and Tools

4. Click the **run** icon as shown in **Figure 18**.

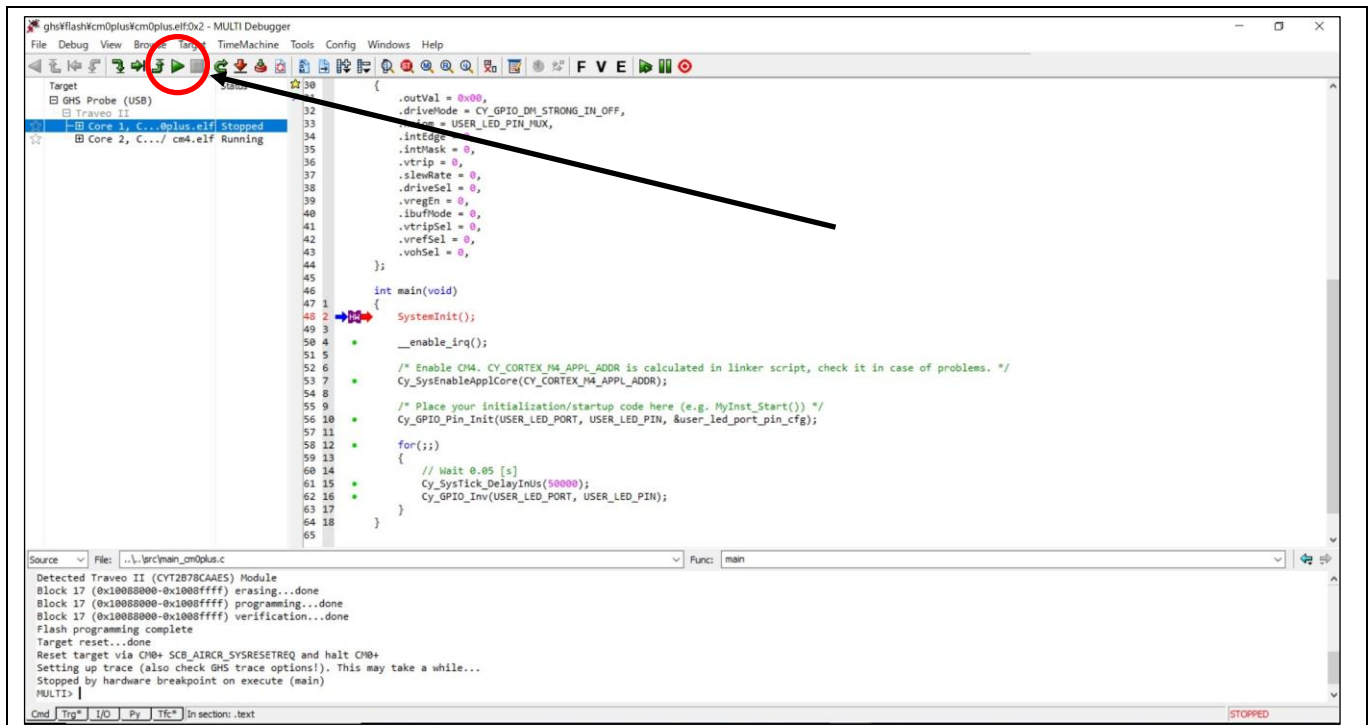

Figure 18 Execution on Flash Memory

When these operations are performed, both CM0+ and CM4 programs will be in the program running state and debugging will be possible. The board LED starts blinking.

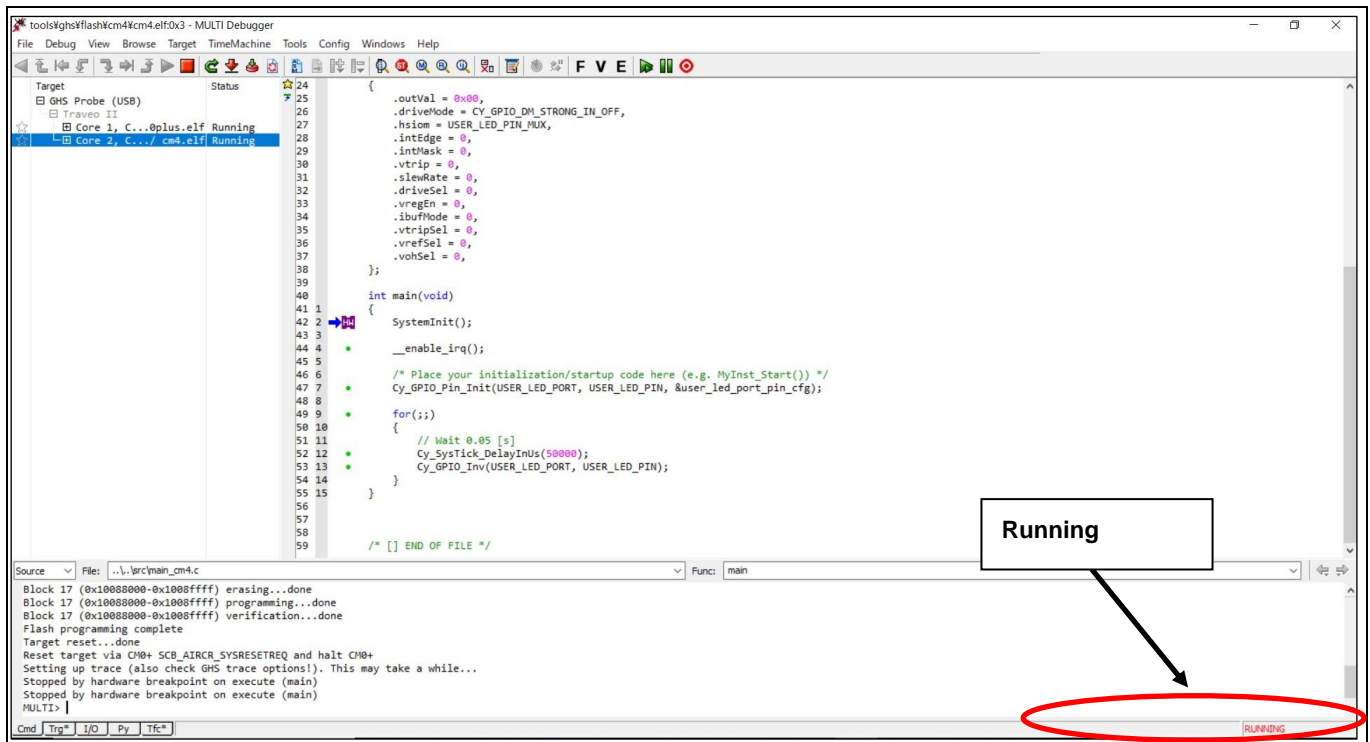

Figure 19 Running on the Flash Memory

Development Environment and Tools

3.5 Example Usage of SDL with IAR Embedded Workbench for Arm

3.5.1 Environment for SDL

This section describes the operation with CYT2B7 series SDL as an example.

SDL Operational Conditions:

- CPU: CYT2B7 series
- Target Board: Traveo II Evaluation board
- IDE: IAR Embedded Workbench for Arm (compiler version 8.42.1)
- Used API Module GPIO

3.5.2 Install GHS MULTI and SDL

Install IAR Embedded Workbench for Arm, set the license, and I-Jet in advance.

Install SDL according to SDL's instructions in advance.

3.5.3 Setup with IAR EWARM

There are two debugging methods:

- 1) Debugging with Download on the RAM
- 2) Debugging with Download on the Flash Memory

3.5.3.1 Debugging with Download on the RAM

1. Start IAR EW for Arm and open the SDL work space file:

`C: \... \TVII_Sample_Driver_Library_revision \tviibe1m \tools \iar \sram \tviibe1m_sram_cm0plus_template.eww`

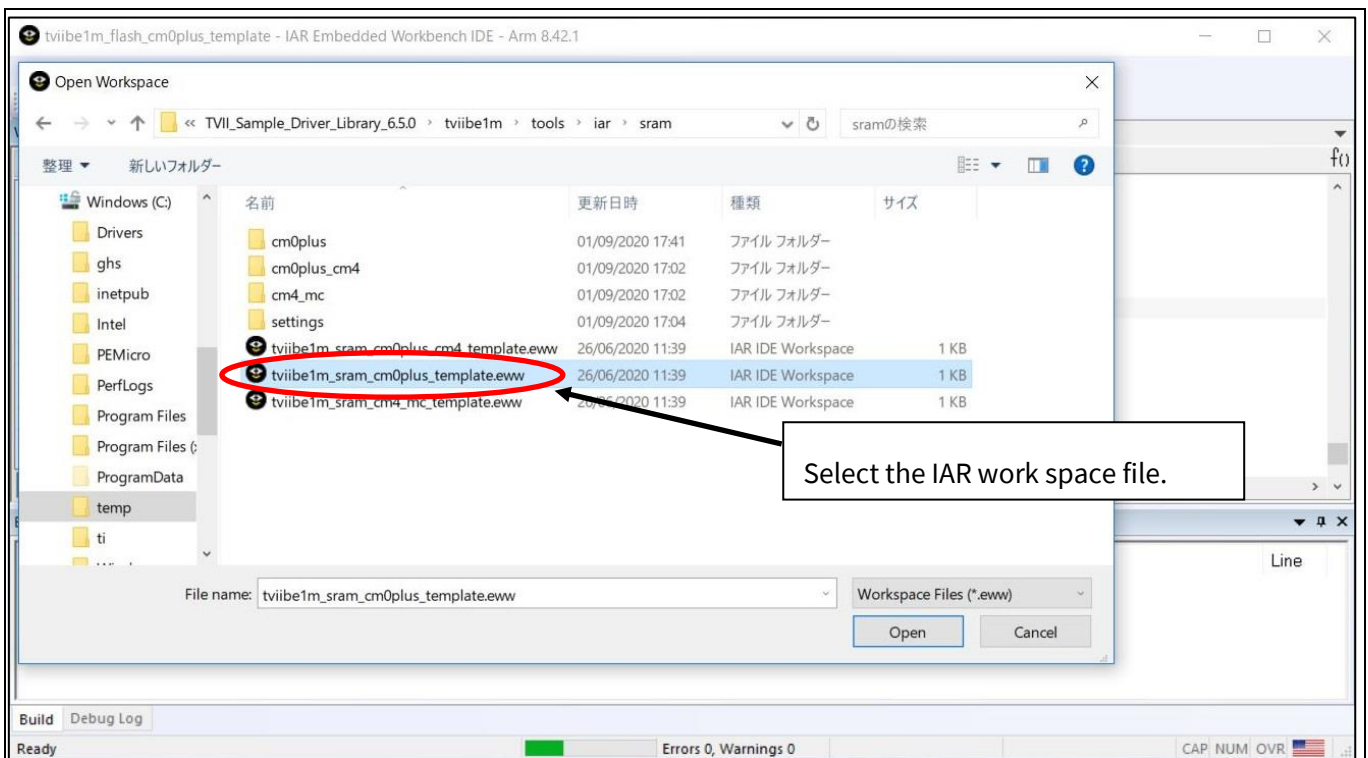

Figure 20 Select the SDL Workspace

Development Environment and Tools

- For the build, select *cm0plus.eww* on the workspace and right-click and select **Rebuild All** as shown in **Figure 21**. The Rebuild All process starts, and no errors and no warnings messages appear as shown in **Figure 22**.

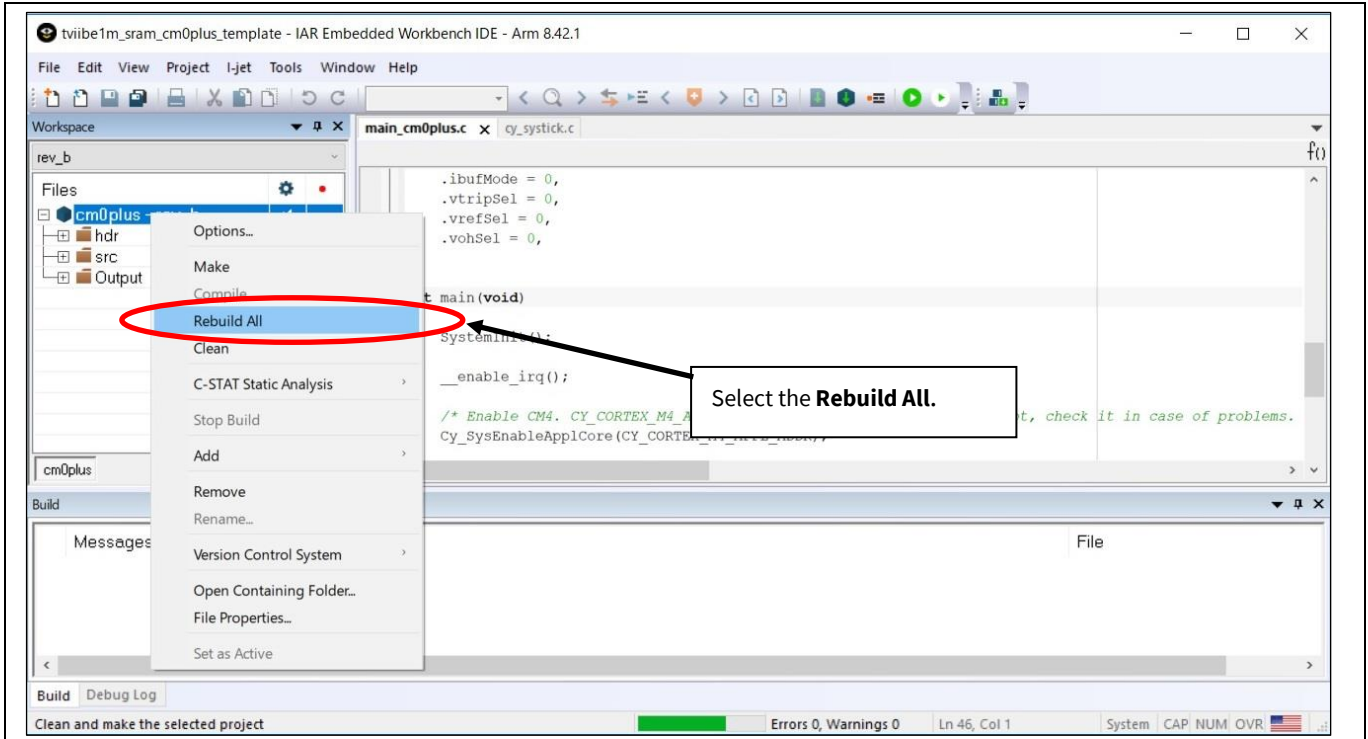

Figure 21 Rebuild the Project of SDL Project

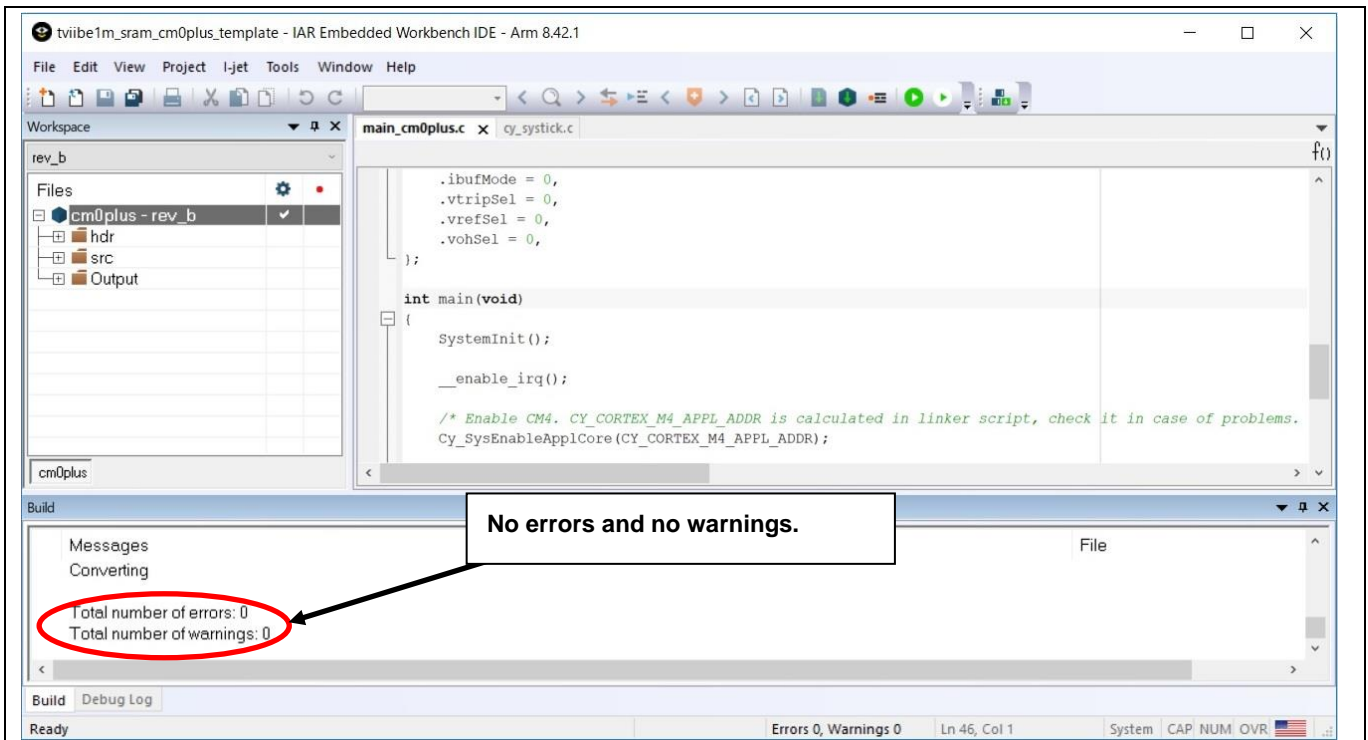

Figure 22 Rebuild Successful of the Project of SDL Project

Development Environment and Tools

3. To load the program to the RAM, click the **Download** icon as shown in **Figure 23**.

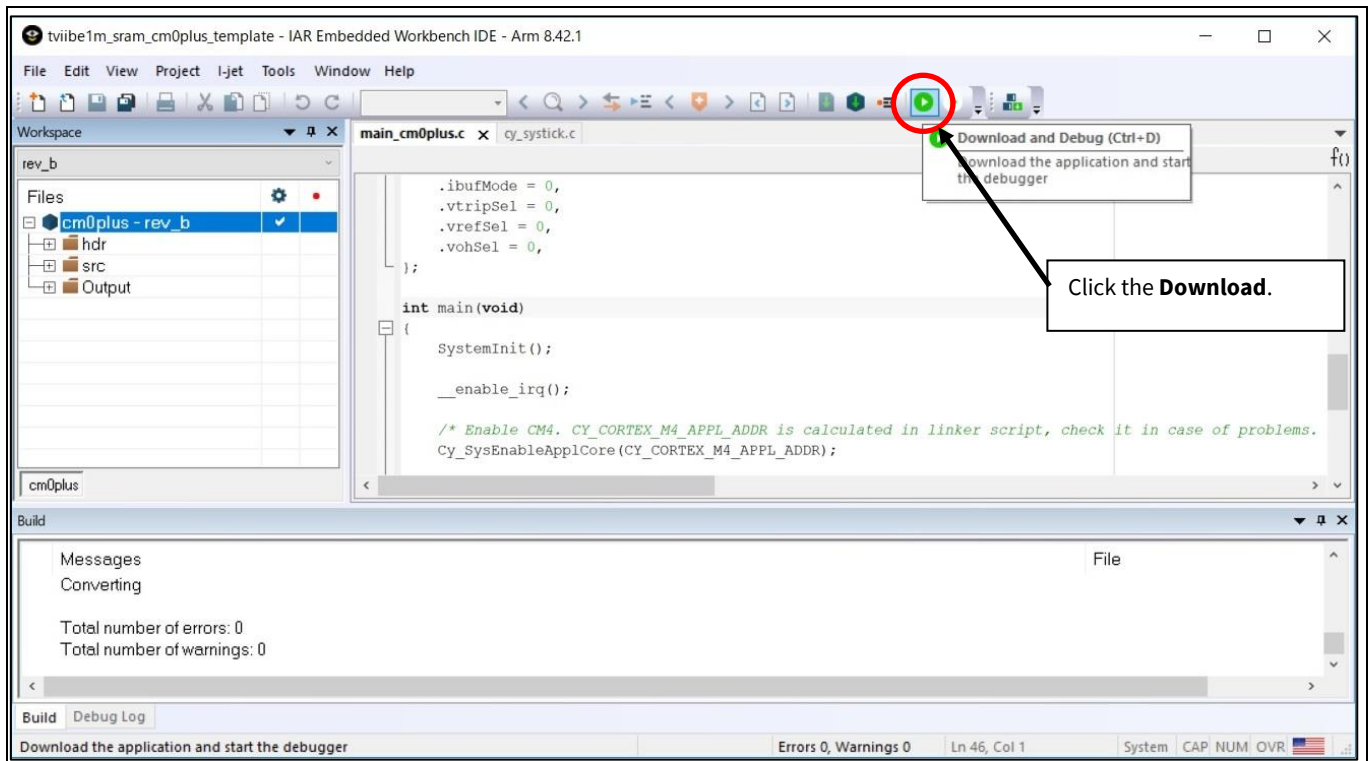

Figure 23 Debug the Project of SDL Project

4. Click the **Go** icon as shown in **Figure 24**.

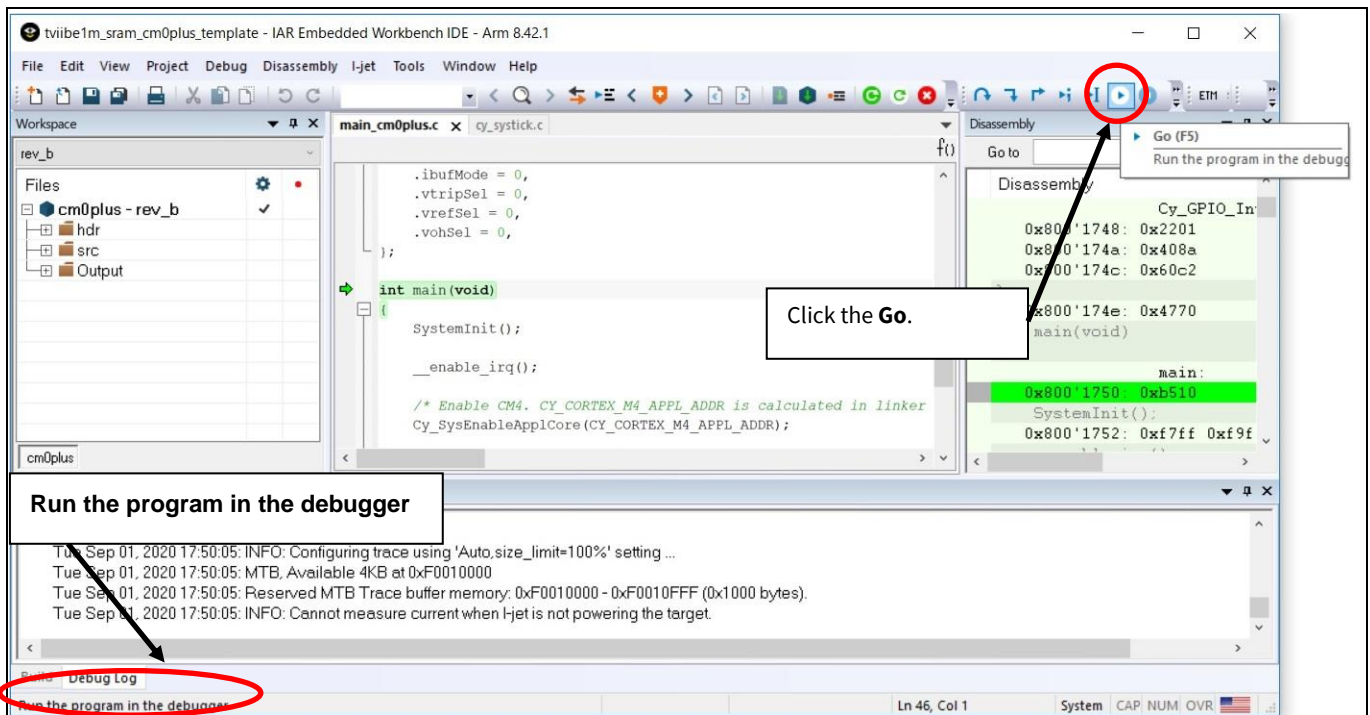

Figure 24 Execution on RAM

Development Environment and Tools

When these operations are performed, both CM0+ programs will be in the program running state and debugging will be possible as shown in **Figure 28**. The board LED starts blinking.

3.5.3.2 Debugging with Download on the Flash Memory

1. Start the IAR EW for Arm and open the SDL work space file:

`C:\...\TVII_Sample_Driver_Library_revision\tviibe1m\tools\iar\flash\tviibe1m_flash_cm0plus_template.eww`

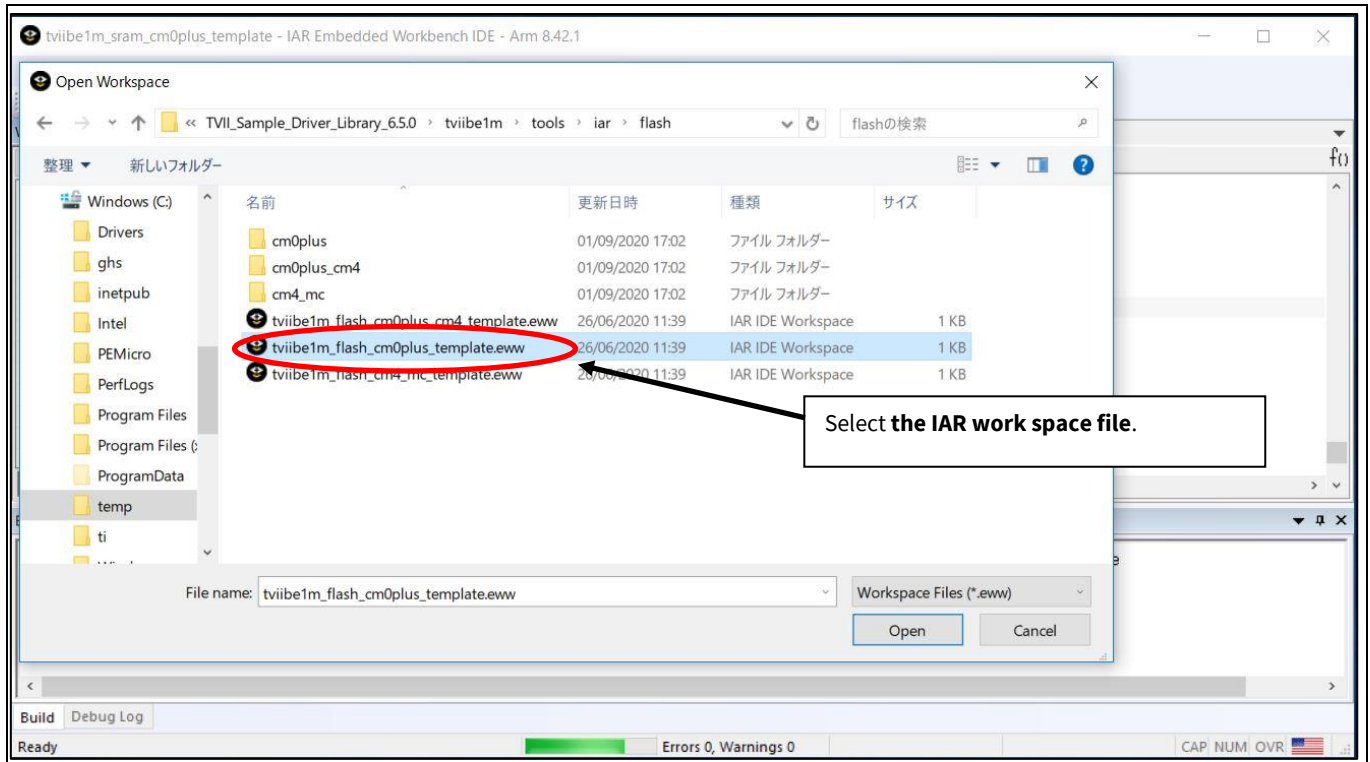

Figure 25 Select the SDL Workspace

Development Environment and Tools

- For the build, select *cm0plus.eww* on the workspace and right-click and select **Rebuild All** as shown in **Figure 26**. The Rebuild All process starts, and no errors and no warnings messages appear as shown in **Figure 27**.

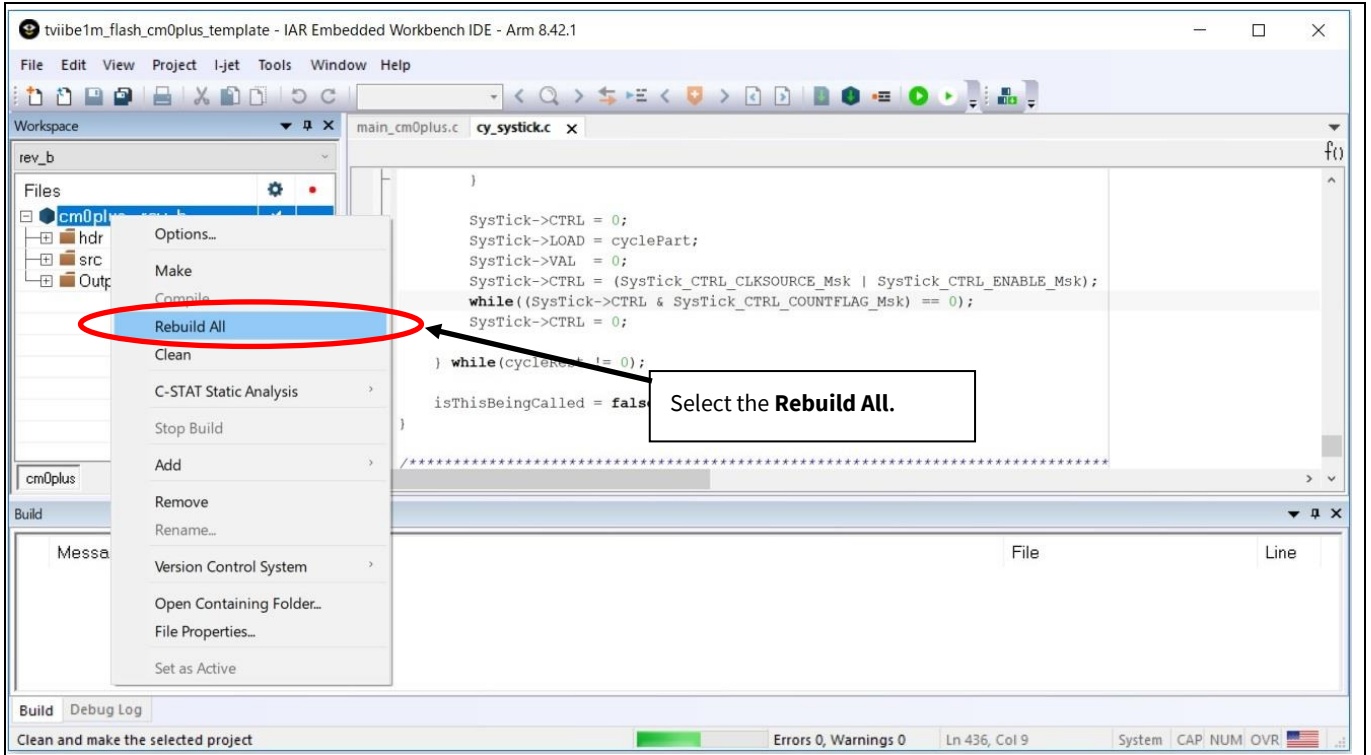

Figure 26 Rebuild the Project of SDL Project

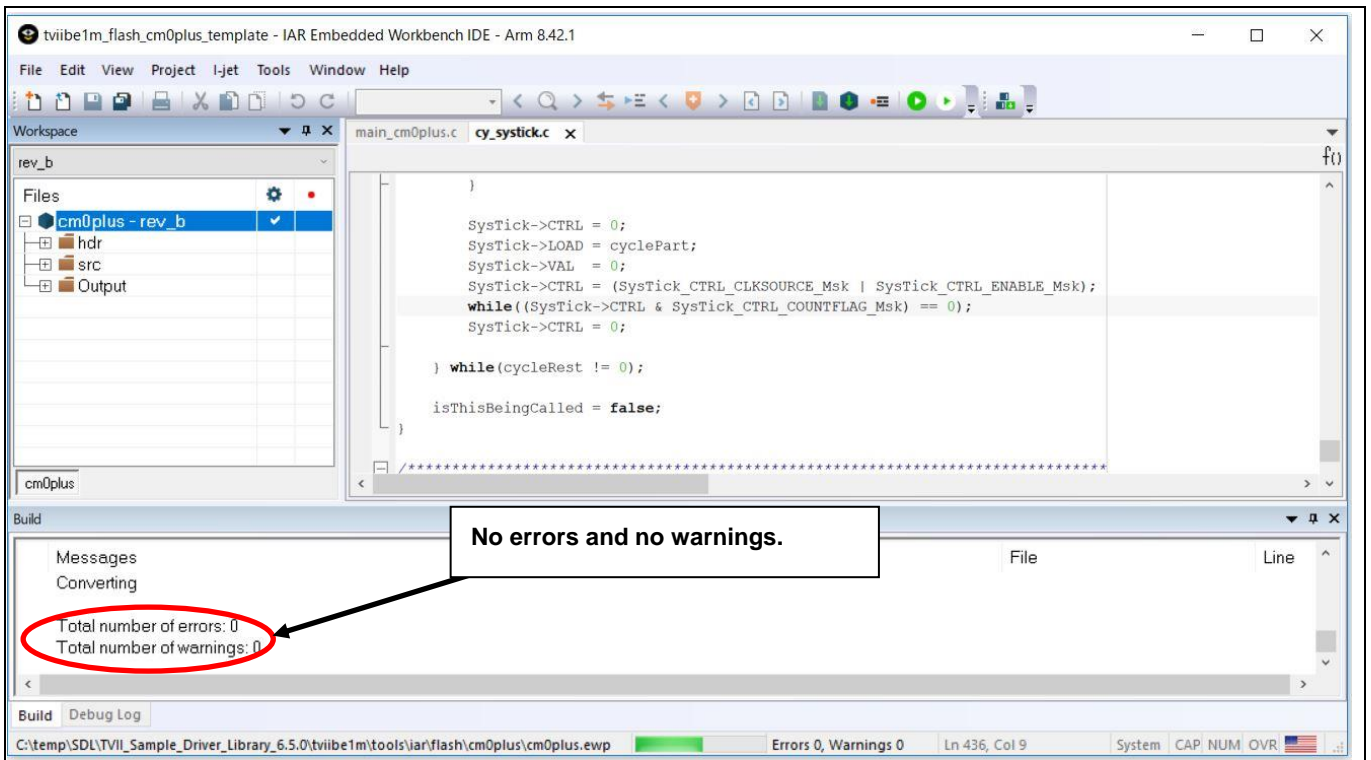

Figure 27 Rebuild Successful of the Project of SDL Project

Development Environment and Tools

3. To load the program to the Flash memory, click the **Download** icon as shown in **Figure 28**.

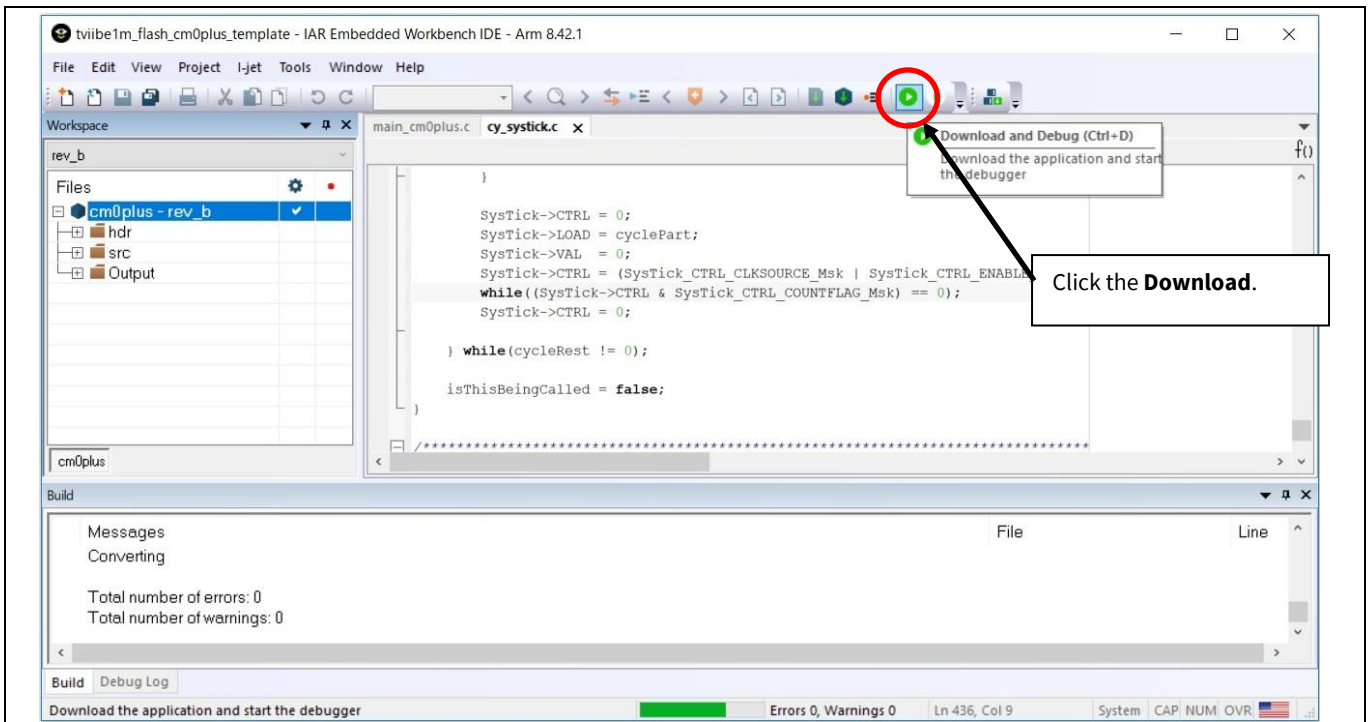

Figure 28 Debug the Project of SDL Project

4. Click the **Go** icon as shown in **Figure 29**.

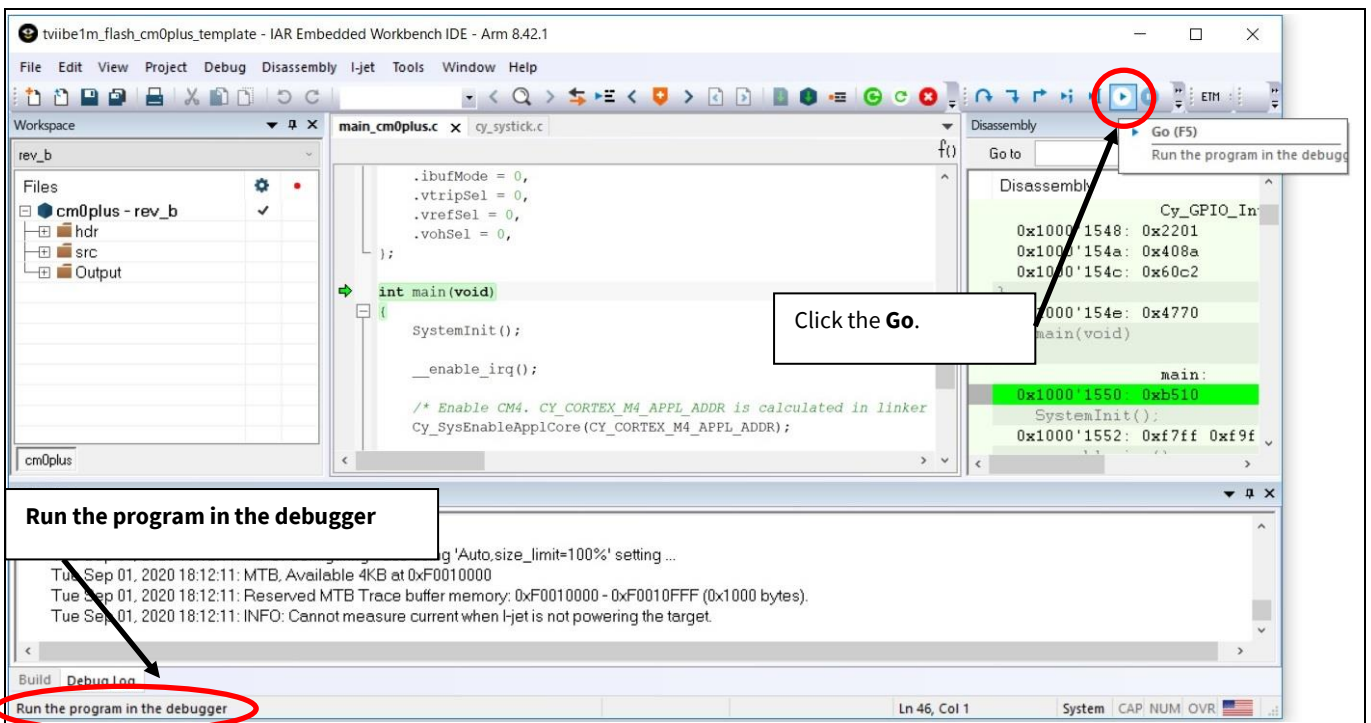

Figure 29 Execution on Flash memory

When these operations are performed, both CM0+ programs will be in the program running state and debugging will be possible as shown in **Figure 29**. The board LED starts blinking.

Development Environment and Tools

3.6 Development Tools

Table 5 lists the details of support development tools.

Table 5 Development Tools

Vender	Emulators/Probes	Compiler
Green Hills Software Ltd.	GHS Probe (5.6.4/5.6.6)	MULTI V7 (version 7.1.4)
IAR Systems AB	I -JET	Embedded Workbench for Arm (8.42.1)
iSYSTEM AG	i-TAG Family	-
Lauterbach GmbH	TRACE 32-ICE	-

3.7 Flash Programming Tools

Table 6 lists the supported flash programming tools. Cypress MiniProg3/4 programmer is for development purposes. For mass production purposes, JTAG programmer from a third-party is suitable.

Table 6 Flash Programming Tools

Vender	Flash Programmer	Software	Notes
Cypress Semiconductor Corp.	Minipro3	Cypress Programmer 1.0	Support only for CYT2B7
	Minipro4	Cypress Auto Flash Utility	
SEGGER Microcontroller GmbH	J-Link	J-Flash	
	Flasher Arm (for mass production)		
DTS Insight Corp.	NETIMPRESS AF430	Remote Controller AZ490	

CYTVII-B-E-1M-xxx-CPU/CYTVII-B-H-8M-xxx-CPU/CYTVII-C-2D-6M-xxx-CPU has the Cortex Debug Connector for both functions JTAG and SWD. SWD compatible with MiniProg3.

Table 7 lists the Pin assignment for Cortex Debug Connector.

Table 7 Cortex Debug Connector

Pin	Signal
1	VCC
2	SWDIO/TMS
3	GND
4	SWDCLK/TCK
5	GND
6	SWO/TDO
7	KEY
8	NC/TDI
9	GNDDetect
10	nRESET

Summary

4 Summary

This application note guided you to set up Traveo II development environment. Cypress provides a wealth of evaluation boards and sample software to help you get started with Traveo II family. To evaluate the CYT2/CYT3/CYT4 series evaluation boards, contact your sales representative or [Cypress Technical Support](#).

Glossary

5 Glossary

Table 8 Glossary

Terms	Description
ADC	Analog-to-Digital Converter
ASIL-B	Automotive Safety Integrity Level-B
CAN FD	Controller Area Network with Flexible Data rate
CMSIS	Cortex Microcontroller Software Interface Standard
Crypto	Cryptography Accelerator
CXPI	Clock Extension Peripheral Interface
DMA	Direct Memory Access
ETM	Embedded Trace Macrocell
EVTGEN	Event Generator
FDP-Link	Flat Panel Display Link
Gigabit Ethernet	1 Gbps Ethernet
GPIO	General-Purpose Input/Output
IPC	Inter-Processor Communication
JTAG	Joint Test Action Group
LIN	Local Interconnect Network
MCWDT	Multi-Counter Watchdog Timers
MPU	Memory Protection Unit
LVDS	Low Voltage Differential Signaling
MIPI	Mobile Industry Processor Interface
CSI2	Camera Serial Interface-2
PROT	Protection Unit
RWW	Read-While-Write
SCB	Serial Communication Block
SDL	Sample Driver Library
SWD	Single Wire Debug
SYSCLK	System Clock
SYSFLT	System Fault
SYSINT	System Interrupt
SYSLIB	System Library
SYSMPM	System Power Management
REGHC	High Current Regulator
SYSRTC	System Real-Time Clock
SYSTICK	Systick Timer
SYSWDT	Free running Watchdog Timer
TCPWM	Timer Counter PWM
TRIGMUX	Trigger Multiplexer

Related Documents

6 Related Documents

The following are the Traveo II family series application notes, datasheets and Technical Reference Manuals. Contact [Technical Support](#) to obtain these documents.

Table 9 Related Documents

Documents	Description
Application Notes	
Hardware Design Guide for the Traveo™ II Automotive Body Family	Describes how to set up a hardware environment for Traveo™ II.
Device Datasheet	
CYT2B7 Datasheet 32-Bit Arm® Cortex®-M4F Microcontroller Traveo™ II Family	Describes the functions and electrical specifications of the target product. It also includes product specific information such as Address Map, I/O Map, Pin Assignment, Alternate Function Pin Assignments, Interrupt Source List, Trigger Group, Peripheral Clocks, Faults, Bus Masters
CYT2B9 Datasheet 32-Bit Arm® Cortex®-M4F Microcontroller Traveo™ II Family	
CYT4BF Datasheet 32-Bit Arm® Cortex®-M7 Microcontroller Traveo™ II Family	
CYT4DN Datasheet 32-Bit Arm® Cortex®-M7 Microcontroller Traveo™ II Family	
CYT3BB/4BB Datasheet 32-Bit Arm® Cortex®-M7 Microcontroller Traveo™ II Family	
Architecture Technical Reference Manual	
Traveo™ II Automotive Body Controller Entry Family Architecture Technical Reference Manual (TRM)	Describes the architecture and functioning of product family
Traveo™ II Automotive Body Controller High Family Architecture Technical Reference Manual (TRM)	
Traveo™ II Automotive Cluster 2D Family Architecture Technical Reference Manual (TRM)	
Registers Technical Reference Manual	
Traveo™ II Automotive Body Controller Entry Registers Technical Reference Manual (TRM) for CYT2B7	Describes the registers list, the initial values, and attributes of the registers of product family
Traveo™ II Automotive Body Controller Entry Registers Technical Reference Manual (TRM) for CYT2B9	
Traveo™ II Automotive Body Controller High Registers Technical Reference Manual (TRM) for CYT4BF	
Traveo™ II Automotive Body Controller High Registers Technical Reference Manual (TRM) for CYT3BB/4BB	
Traveo™ II Automotive Cluster 2D Registers Technical Reference Manual (TRM)	

Revision history

Revision history

Document version	Date of release	Description of changes
**	2017-12-26	New application note.
*A	2019-01-24	Updated Associated Part Family as “Traveo II Family CYT2B/CYT4B Series”. Added target part numbers “CYT2B9 Series” and “CYT4BF Series” related information in all instances across the document.
*B	2019-05-07	Updated Associated Part Family as “Traveo™ II Family CYT2B/CYT4B/CYT4D Series”. Added target part numbers “CYT4D Series” related information in all instances across the document. Updated Feature Set: Added “CYT4D Series”. Updated Development Environment and Tools: Updated Peripheral Drivers: Updated Peripheral Drivers List: Updated “Table 4. Peripheral Drivers List”. Updated Example Usage of SDL with GHS MULTI: Added “Install GHS MULTI and SDL”. Added “Setup debug script and configuration files”. Updated Flash Programming Tools: Updated “Table 6. Flash Programming Tools”. Updated Glossary. Updated Related Documents.
*C	2020-03-24	Updated Associated Part Family as “Traveo™ II Family CYT2/CYT3/CYT4 Series”. Changed target part numbers from “CYT2B/CYT4B/CYT4D Series” to “CYT2/CYT4 Series” in all instances across the document. Added target part numbers “CYT3 Series” in all instances across the document.
*D	2020-09-14	Updated Development Environment and Tools: Updated Example Usage of SDL with GHS MULTI: Updated Setup with MULTI: Updated almost entire section. Added “Example Usage of SDL with IAR Embedded Workbench for Arm”.
*E	2021-03-29	Added Summary. Updated to Infineon template.

Trademarks

All referenced product or service names and trademarks are the property of their respective owners.

Edition 2021-03-29

Published by

Infineon Technologies AG

81726 Munich, Germany

© 2021 Infineon Technologies AG.

All Rights Reserved.

Do you have a question about this document?

Go to www.cypress.com/support

Document reference

002-20118 Rev. *E

IMPORTANT NOTICE

The information contained in this application note is given as a hint for the implementation of the product only and shall in no event be regarded as a description or warranty of a certain functionality, condition or quality of the product. Before implementation of the product, the recipient of this application note must verify any function and other technical information given herein in the real application. Infineon Technologies hereby disclaims any and all warranties and liabilities of any kind (including without limitation warranties of non-infringement of intellectual property rights of any third party) with respect to any and all information given in this application note.

The data contained in this document is exclusively intended for technically trained staff. It is the responsibility of customer's technical departments to evaluate the suitability of the product for the intended application and the completeness of the product information given in this document with respect to such application.

For further information on the product, technology, delivery terms and conditions and prices please contact your nearest Infineon Technologies office (www.infineon.com).

WARNINGS

Due to technical requirements products may contain dangerous substances. For information on the types in question please contact your nearest Infineon Technologies office.

Except as otherwise explicitly approved by Infineon Technologies in a written document signed by authorized representatives of Infineon Technologies, Infineon Technologies' products may not be used in any applications where a failure of the product or any consequences of the use thereof can reasonably be expected to result in personal injury.