

**Model TB750G
Right Angle Scattered Light
Turbidimeter**

IM 12E01A06-01E

◆ INTRODUCTION

■ Structure of this Manual

This manual describes the specifications, installation, operation, maintenance, and troubleshooting for the TB750G Right Angle Scattered Light Turbidimeter. To use this instrument correctly, read this manual thoroughly.

■ Specification Check

When the instrument arrives, unpack the package with care and check that the instrument has not been damaged during transportation. Please check that the product received meet the specified specifications by confirming the model code indicated on the nameplate. For details of the model code, refer to Section 2.4.1 on page 2-7.

■ Before Measurement

The TB750G turbidimeter is preset with defaults prior factory shipment. Before measurement, verify that these factory default settings meet the operating conditions and if necessary, reconfigure parameters. For checking the default settings and recording changed parameters, use an Operation Parameter Setting List at the end of this manual.

◆ Symbols and Notations Used in this Manual

■ Symbols

The following symbols are used in this manual.



WARNING

Indicates hazards, e.g., electric shock, which will result in serious personal injury or death if instructions are not followed.



CAUTION

Indicates that damage to software or hardware, or system failures could occur if instructions are not followed.



NOTE

Instructions needed to understand the operation and functions.



TIP

Supplementary information



SEE ALSO

Related items or pages

■ Notations

In this manual, operation keys, display messages, indicators, and LED lamps on the instrument are denoted in the following manner.

1. Operation keys are denoted by brackets [] – for example:

 : [YES] key

2. Indicators, messages, and numerical data on the display are denoted as follows:

Status indicator : [HOLD] indicator

Key indicator : [YES] indicator

Message display: { *WASH }

Data display: { 2.05 } (when lit), { 2.05 } (when flashing)

3. Status lamps and modes on the front panel are denoted as follows:

Contact status LED lamp: <●S1> (when lit), <○S1> (when not lit)

Measurement mode ▶ MEASURE: <MEASURE> mode

4. Flashing state on the display is denoted in light gray – for example:



(Flashing) (Lit)

◆ Notice

■ About this Manual

- This manual should be passed on to the end user.
- This manual should be read thoroughly before operating the instrument.
- This manual explains the functions contained in this product, but does not warrant that they will suit the particular purpose of the user.
- The contents of this manual shall not be reproduced or copied, in part or in whole, without permission.
- The contents of this manual are subject to change without prior notice.
- Every effort has been made to ensure the accuracy in the preparation of this manual. However, if any errors or omissions are noticed, please contact the nearest Yokogawa representative or sales office.

■ Protection, Safety, and Modification of the Product

- The safety instructions described in this manual should be strictly observed to ensure safety both of the product and the system controlled by the product.
- A protection or safety circuit should be installed externally, if needed. Do not attempt to modify or add such circuit to the inside of the equipment.

■ Limitation of Liability

- Yokogawa grants no warranties other than the express warranty set forth under the warranty provisions.
- Yokogawa shall not be liable to you or any third party for any damage, including consequential or incidental damages, arising out of or in connection with the use of this equipment, defects beyond our knowledge, or any other contingency beyond our control.

◆ After-Sales Warranty

- Do not modify the product.
- During the warranty period, for repair under warranty carry or send the product to the local sales representative or service office. Yokogawa will replace or repair any damaged parts and return the product to you.
- Before returning a product for repair under warranty, provide us with the model name and serial number and a description of the problem. Any diagrams or data explaining the problem would also be appreciated.
- If we replace the product with a new one, we won't provide you with a repair report.
- Yokogawa warrants the product for the period stated in the pre-purchase quotation. Yokogawa shall conduct defined warranty service based on its standard. When the customer site is located outside of the service area, a fee for dispatching the maintenance engineer will be charged to the customer.
- In the following cases, customer will be charged repair fee regardless of warranty period.
 - Failure of components which are out of scope of warranty stated in instruction manual.
 - Failure caused by usage of software, hardware or auxiliary equipment, which Yokogawa did not supply.
 - Failure due to improper or insufficient maintenance by user.
 - Failure due to misoperation, misuse or modification which Yokogawa does not authorize.
 - Failure due to power supply (voltage, frequency) being outside specifications or abnormal.
 - Failure caused by any usage out of scope of recommended usage.
 - Any damage from fire, earthquake, storms and floods, lightning, disturbances, riots, warfare, radiation and other natural changes.
- Yokogawa does not warrant conformance with the specific application at the user site. Yokogawa will not bear direct/indirect responsibility for damage due to a specific application.
- Yokogawa will not bear responsibility when the user configures the product into systems or resells the product.
- Maintenance service and supplying repair parts will be covered for five years after the production ends. For repair for this product, please contact the nearest sales office described in this instruction manual.

Model TB750G Right Angle Scattered Light Turbidimeter

IM 12E01A06-01E 5th Edition

CONTENTS

- ◆ INTRODUCTIONi
- ◆ Symbols and Notations Used in this Manualii
- ◆ Noticeiii
- ◆ After-Sales Warrantyiv
- 1. OVERVIEW 1-1
 - 1.1 Measurement Principle 1-2
 - 1.2 Turbidity Standards 1-3
 - 1.2.1 Zero Standard 1-3
 - 1.2.2 Turbidity Standards 1-3
 - 1.3 Formazin Standard Solution 1-4
 - 1.3.1 Preparing a Formazin Standard Stock Solution 1-4
 - 1.3.2 Preparing a Formazin Calibration Standard Solution 1-5
- 2. SPECIFICATIONS 2-1
 - 2.1 Standard Specifications 2-1
 - 2.2 Characteristics 2-6
 - 2.3 Optional Specifications 2-6
 - 2.4 Model and Codes 2-7
 - 2.4.1 TB750G Right Angle Scattered Light Turbidimeter 2-7
 - 2.4.2 Zero Turbidity Filter Assembly 2-7
 - 2.4.3 Accessories 2-8
 - 2.4.4 Consumables 2-8
 - 2.4.5 Head Tank 2-8
 - 2.5 External Dimensions 2-9
 - 2.5.1 TB750G Right Angle Scattered Light Turbidimeter 2-9
 - 2.5.2 Zero Turbidity Filter Assembly 2-10
 - 2.6 Piping Diagram 2-11
 - 2.7 Connection Diagram 2-11
- 3. INSTALLATION, PIPING, AND WIRING 3-1
 - 3.1 Installation 3-1
 - 3.1.1 Unpacking 3-1
 - 3.1.2 Installation Location 3-1
 - 3.1.3 Installation Dimensions 3-2
 - 3.1.4 Preparation 3-6

	3.1.5	Mounting the Converter and Detector	3-8
3.2	Wiring		3-11
	3.2.1	Wiring Required for the TB750G	3-11
	3.2.2	Cable Inlet Port	3-13
	3.2.3	Analog Output Wiring.....	3-14
	3.2.4	Contact Input (Remote Range Switching) Wiring.....	3-15
	3.2.5	Contact Output (S1, S2 and FAIL) Wiring.....	3-16
	3.2.6	Range Contact Output Wiring.....	3-18
	3.2.7	Serial Communication Wiring	3-19
	3.2.8	Checking Wiring between the Converter and the Detector	3-19
	3.2.9	Power and Ground Wiring	3-20
	3.2.10	External Ground Wiring for the Converter	3-21
	3.2.11	External Ground Wiring for the Detector.....	3-21
	3.2.12	Power Wiring for the Ultrasonic Oscillator (When Option Code “/US” is Specified).....	3-22
	3.2.13	Wiring to the Ultrasonic Transducer (When Option Code “/US” is specified)	3-23
3.3	Piping		3-24
	3.3.1	System Using an Open Head Tank.....	3-24
	3.3.2	System Using a Pressurized Head Tank	3-28
	3.3.3	System without a Head Tank	3-31
4.	OPERATION		4-1
	4.1	Preparation	4-1
	4.1.1	Installation, Piping and Wiring Check	4-1
	4.1.2	Supplying Power.....	4-1
	4.1.3	Warm-up	4-2
	4.1.4	Setting and Checking Parameters.....	4-2
	4.1.5	Zero and Span Calibrations (Using Filtered Water as Zero Reference).....	4-3
	4.1.6	Zero and Span Calibrations (2-point Calibration Using Standard Solutions).....	4-4
	4.1.7	Supplying a Water Sample and Adjusting the Flow Rate	4-6
	4.1.8	Operation Check.....	4-7
	4.2	Normal Operation	4-8
	4.2.1	When a Failure Occurs	4-8
	4.2.2	Inspection and Maintenance.....	4-8
	4.2.3	When Sample Water Supply is Cut Off.....	4-8
	4.2.4	When a Power Failure Occurs.....	4-8
	4.3	Operation Shutdown and Restart	4-8
	4.3.1	Shutdown	4-8
	4.3.2	Restart.....	4-8
5.	CONVERTER OPERATION		5-1
	5.1	Outline	5-1
	5.1.1	Operation, Setting, and Service Levels	5-1

5.1.2	Key Operations	5-2
5.1.3	Password	5-3
5.2	Key Operation Procedures	5-3
5.2.1	Operation Panel	5-3
5.2.2	Panel Display upon Power Up	5-5
5.2.3	Basic Key Operations	5-6
5.3	Setting Parameter List.....	5-8
5.3.1	Setting Parameters at the Operation Level	5-8
5.3.2	Setting Parameters at the Setting Level	5-9
5.3.3	Setting Parameters at the Service Level	5-10
6.	PROCEDURES FOR SETTING PARAMETERS.....	6-1
6.1	Parameter Setting at the Operation Level	6-1
6.2	Parameter Setting at the Setting Level	6-6
6.3	Parameter Setting at the Service Level	6-11
7.	MAINTENANCE.....	7-1
7.1	Inspection/Maintenance Items and Intervals	7-1
7.2	Removing Sediment from the Measurement Cell	7-2
7.3	Washing the Measurement Cell.....	7-3
7.4	Washing the Head Tank.....	7-5
7.5	Lamp Replacement.....	7-6
7.6	Calibration Using Turbidity Standards	7-7
7.6.1	Zero Calibration Using Zero Water	7-10
7.6.2	Span Calibration Using the Check Block.....	7-11
7.6.3	Span Calibration Using a Formazin Standard Solution	7-14
7.7	2-point Calibration Using Turbidity Standard Solutions	7-16
7.8	Grab Sample Calibration	7-19
7.9	Checking and Replacing Desiccants.....	7-21
7.10	Checking the Operation of Each Input/Output	7-22
7.10.1	Checking the Operation of the Analog Output	7-22
7.10.2	Checking the Operation of the Contact Output.....	7-23
7.10.3	Checking the Operation of the Contact Input	7-24
7.11	Replacing the Zero Turbidity Filter Element	7-25
7.12	Fuse Replacement	7-26
7.13	Pipe Cleaning	7-27
7.14	Cleaning the Front Covers of the Detector and the Converter	7-28
7.15	Spare Parts	7-28
8.	TROUBLESHOOTING	8-1
8.1	When a Failure Occurs and the FAIL Lamp Turns On.....	8-1
8.2	When a Failure Occurs but the FAIL Lamp Does Not Turn On	8-5
8.3	Error Code List	8-6
	Worksheet for Operation Parameter Setting.....	App-1

Customer Maintenance Parts List..... CMPL 12E01A06-01E
Revision Informationi

1. OVERVIEW

There are increasing demands for good quality water for both industrial-use and drinking water applications because of rapid industrial development and consumer demands for better quality of life. A large amount of the waste water from both applications has been drained or discharged into rivers, causing pollution to worsen year after year. This has caused serious social problems.

Therefore, turbidimeters, conventionally used for the operation and control of water purification plants, are nowadays being required to measure the amount of matter suspended in various sorts of industrial waste water and to measure the turbidity of chemical processes.

Since their sales began in 1959, Yokogawa's turbidimeters have been continuously developed and improved using various measurement principles suited for various applications. With its many achievements, Yokogawa has earned its customers' confidence.

Developed based on years of experience and applications in process fields, the TB750G Right Angle Scattered Light Turbidimeter provides highly reliable measurement and improved maintainability which improve upon what previous models could offer. A wide range of options are available to meet users' various needs.

The TB750G is a process turbidimeter employing the right angle light scattering method, and has the following features.

- Highly reliable measurement with excellent linearity and repeatability
 - Linearity: $\pm 2\%$ of reading or ± 0.01 NTU, whichever is greater
 - Repeatability: $\pm 1\%$ of reading or ± 0.002 NTU, whichever is greater
 - Display resolution: 0.001 NTU
- Easy-to-clean measurement cell
- Compact, lightweight converter and detector
- User configurable analog output range
 - Analog output range: 0-0.2 NTU to 0-100 NTU
- Analog output range switching (2 or 3 ranges)
- Enhanced self-diagnostic function as standard
 - Light source failure, input element failure, calibration failure, various circuit failures, etc.
- Detector designed to remove influence of air bubbles
- A wide range of measurement conditions
 - Low flow rate: 0.05 to 20 l/min
 - High pressure: Up to 500 kPa
 - Sample temperature: 0 to 50°C
- Detector can be connected for in-line analysis
- 2 analog outputs, 3 relay contact outputs, and 1 serial communication
- Many options available
- Ultrasonic transducer and oscillator for ultrasonic cleaning
- Various head tanks to accommodate application requirements

1.1 Measurement Principle

The measuring system of the TB750G turbidimeter, comprised of a detector and a converter, employs the right angle light scattering method. This section describes the structure of the measuring system and the measurement principle.

The detector is comprised of a measurement cell, a light source unit, and a sensing unit. A water sample flows upward through the measurement cell: it flows into the cell from the bottom and flows out from the top. A tungsten lamp enclosed in the light source unit sends light, through a lens, to the water in the measurement cell. The incident light passes through the water, and the transmitted light reaches a receiver, which is located on the opposite side of the light source unit, and is absorbed in a darkroom equivalent to a black body. The incident light is also scattered by turbidity particles in the water sample. The intensity of this scattered light, L , is proportional to the turbidity as shown below.

$$L = K \cdot Q \cdot S$$

Where:

K: a turbidity-derived constant

Q: the amount of lamp light

S: the turbidity

A turbidity element (a silicon photodiode) in the sensing unit detects light scattered at a right angle to the incident light beam and sends the output signal to the converter. A reference element incorporated in the light source unit measures the amount of lamp light, Q , and sends the detection signal to the converter.

The measuring circuit of the converter is housed, together with an operation panel and a terminal block for external wiring, in a sealed aluminum alloy enclosure. The circuit amplifies the input voltage from the sensing unit, calculates, displays the turbidity, and sends the analog output signal (4-20 mA DC) corresponding to the measuring range and the serial communication data. Either of 4-20 mA DC or 0-20 mA DC can be selected for analog output 2.

The turbidity reading and output signal are corrected for the change of the amount of lamp light based on the input from the reference element in the light source unit.

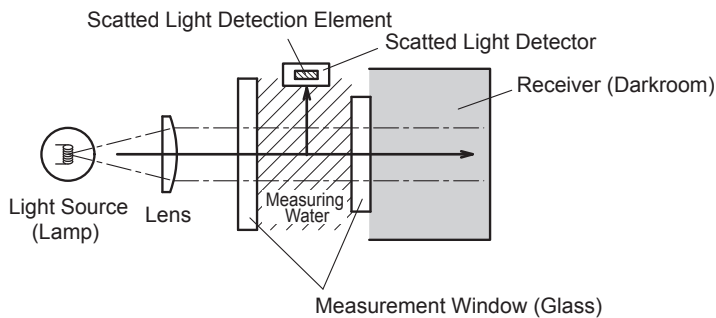

F1-1E.ai

Figure 1.1 Measurement Principle

1.2 Turbidity Standards

The turbidity standards are used as reference for adjusting a zero or span point of a turbidity meter.

1.2.1 Zero Standard

(1) Zero Turbidity Standard Solution

Filtered tap water is used as a zero turbidity standard solution for the TB750G turbidimeter. For zero calibration, tap water should be filtered in two steps: first through a 1 µm filter and then through a 0.2 µm filter. If the measuring range exceeds 2.0 NTU, tap water filtered only through a 1 µm filter, can be used.

Note: The instrument has been pre-calibrated for zero point using tap water filtered through a 0.2 µm filter as a zero turbidity standard solution at the factory before shipment.

(2) Zero Turbidity Filter

The specifications of the zero turbidity filter that can be purchased from Yokogawa is as follows.

Item	1 µm Zero Turbidity Filter	0.2 µm Zero Turbidity Filter
Part number	K9411UA	K9726EF
Piping connection	Rc1/2	Rc1/2
Maximum pressure	500 kPa	500 kPa
Cartridge material	Polypropylene	Polypropylene
Filter size	1 µm	0.2 µm
Accessory	Air vent plug	Air vent plug

1.2.2 Turbidity Standards

(1) Turbidity Standard Solution

A formazin solution is used as a turbidity standard solution for the TB750G turbidimeter.

Note: The instrument has been pre-calibrated for span point using a formazin standard solution at the factory before shipment.

(2) Check Block

A check block used for span check in regular maintenance, is supplied with the turbidimeter.

Note: The turbidity value indicated on the check block has been determined for the turbidimeter of interest based on zero and span calibrations at the factory; it is a unique value, specific to the turbidimeter. Be sure to use the check block supplied with the turbidimeter. Also, special care should be taken when handling a check block. Scratches or dirt on the surface of a check block may affect the turbidity value assigned to the block.



NOTE

Using the supplied check block for span calibration is not approved for US EPA applications. For US EPA applications, perform a 2-point calibration using standard solutions.

**NOTE**

Care must be exercised not to lose the check block supplied with the turbidimeter. The check block has a turbidity value unique to the turbidimeter of interest. Therefore, the same check block cannot be purchased again. If it is lost, contact Yokogawa.

1.3 Formazin Standard Solution

**WARNING**

- The reagents are harmful if inhaled or swallowed.
- In case of contact with skin, flush skin with plenty of soap and water. Seek medical advice, as appropriate, if symptoms appear.
- A Class A extinguisher should be provided in work area.
- Wear protective goggles, lab coat, and protective gloves to prevent skin contact. Use a vent hood in the indoor workplace.
- For details of the chemical handling, refer to the Material Safety Data Sheets (MSDS).

A turbidity standard calibration solution should be prepared by diluting a 400 NTU formazin standard stock solution. This section describes the procedures for preparing a standard stock solution and a diluted solution for calibration.

1.3.1 Preparing a Formazin Standard Stock Solution

(1) Reagents Required

- Hydrazine sulfate, $(\text{NH}_2)_2 \cdot \text{H}_2\text{SO}_4$
- Hexamethylene tetramine, $(\text{CH}_2)_6 \cdot \text{N}_4$

(2) Equipment Required

- Measuring flask, 2 x 100 ml
- Measuring flask, 1000 ml
- Volumetric pipette, 50 ml
- Analytical balance

Note: Class A volumetric flasks and pipets are required.

(3) Procedure

1. Weigh out $1.000 \text{ g} \pm 0.001 \text{ g}$ of hydrazine sulfate with a balance, place it in a 100-ml measuring flask, and add deionized water to make 100 ml (solution A).
2. Weigh out $10.00 \text{ g} \pm 0.01 \text{ g}$ of hexamethylene tetramine with a balance, place it in another 100-ml measuring flask, and add deionized water to make 100 ml (solution B).
3. Make sure that both reagents have been completely dissolved in solutions A and B, respectively. Pipette 50 ml each of solutions A and B into a 1000-ml measuring flask and mix well.
4. Allow the mixed solution to stand for 24 hours at $25 \pm 3^\circ\text{C}$.

5. Bring the total volume to 1000 ml with deionized water.

This is a 400 NTU formazin standard stock solution and its storage life is one month. To make a standard solution of the desired turbidity, dilute this stock solution with deionized water.

1.3.2 Preparing a Formazin Calibration Standard Solution

To make a formazin calibration standard solution, dilute the 400 NTU formazin standard stock solution.

(1) Precautions

- Use clean, high quality laboratory glassware and measure the volume needed accurately.
- To dilute the formazin standard stock solution, use deionized water or water filtered through a 0.2 µm zero turbidity filter.
- Before dilution, mix the stock solution thoroughly.

(2) Procedure

To make a 2000 ml formazin calibration standard solution of the desired turbidity, take the needed volume of the 400 NTU formazin standard stock solution and dilute to 2000 ml.

Turbidity	Aliquot of Stock Solution	Total Volume
20 NTU	100 ml	2000 ml
10 NTU	50 ml	2000 ml
5 NTU	25 ml	2000 ml
2 NTU	10 ml	2000 ml
1 NTU	5 ml	2000 ml

2. SPECIFICATIONS

2.1 Standard Specifications

TB750G Right Angle Scattered Light Turbidimeter

Measurement: Turbidity of finished water and water used in general processes

Measurement method: Right angle light scattering method

Measuring range: 0.000 to 100.0 NTU

Display: 4 digit LCD (6 digits in message area), negative value indication enabled/disabled

Unit: NTU

Resolution: 0.001 NTU

Turbidity standard: Formazin

Analog output:

Number of outputs: 2

Output signal:

Analog output 1: 4 to 20 mA DC, isolated

Analog output 2: 4 to 20 mA DC or 0 to 20 mA DC selectable,
isolated (Both analog outputs are not isolated.)

Load resistance: 550Ω max.

Output range: Configurable within the measuring range

Minimum range: 0 to 0.2 NTU

Maximum range: 0 to 100 NTU

Minimum span: 20% or more of upper limit of the range or 0.2 NTU, whichever is greater.

Note: When auto range switching is selected, lower limit of the range is 0 NTU.

Range switching: Enabled/disabled in either analog output 1 or 2. Not available in both outputs.

Manual (local) range/auto range/remote 2-range/remote 3-range switching
selectable.

Output signal in maintenance: Output hold enabled/disabled

Hold output: Last measured value or fixed value (between 2.0 and 22.0 mA for 4 to 20 mA DC
output; between 0.0 and 22.0 mA for 0 to 20 mA DC output) selectable

Output signal in FAIL: Output hold enabled/disabled

Hold output: Last measured value or fixed value (between 2.0 and 22.0 mA for 4 to 20 mA DC
output; between 0.0 and 22.0 mA for 0 to 20 mA DC output) selectable

Negative value indication: Enabled/disabled

Serial communication:

Number of outputs: 1

Communication signal: RS-422 or RS-232C, isolated

Communication specifications:

Data format: ASCII

Transmission speed: 9600 bps

Parity bit: Even parity

Stop bit: 1

Data length: 8 bits

Transmission method: Asynchronous, non-procedural

Communication description:

Turbidimeter status information:

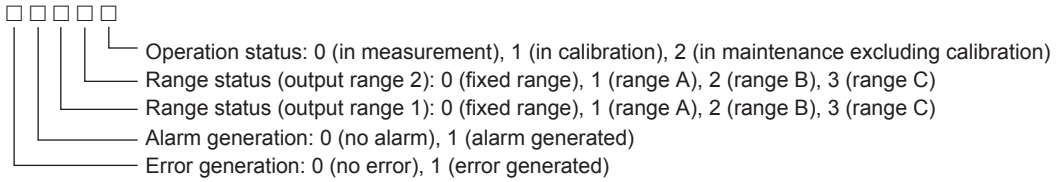

Error information 1 (hexadecimal):

Error code: E102 to E104

Bit configuration: 0 (no error), 1 (error generated)

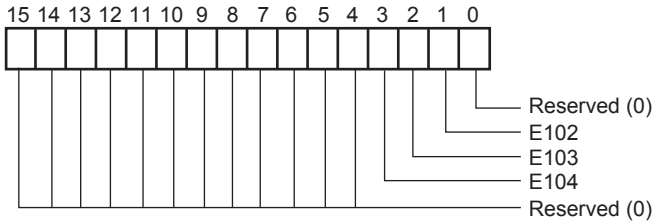

Error information 2 (hexadecimal):

Error code: E201 to E205

Bit configuration: 0 (no error), 1 (error generated)

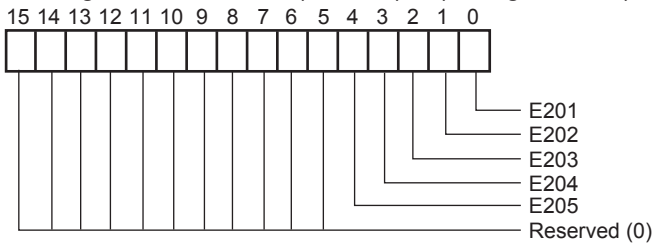

Error information 3 (hexadecimal):

Error code: E301 to E307

Bit configuration: 0 (no error), 1 (error generated)

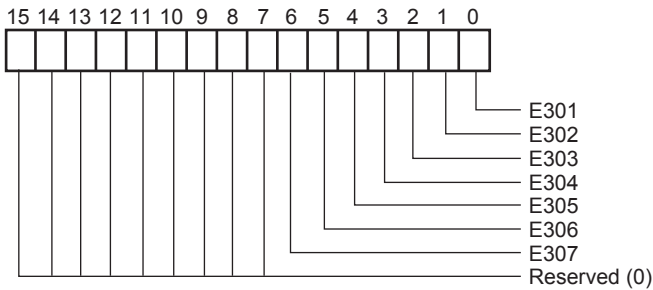

Error information 4 (hexadecimal):

Reserved

Bit configuration

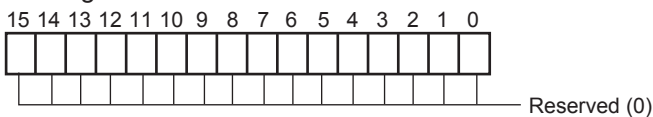

Error information 5 (hexadecimal):

Error code: E321, E322

Bit configuration: 0 (no error), 1 (error generated)

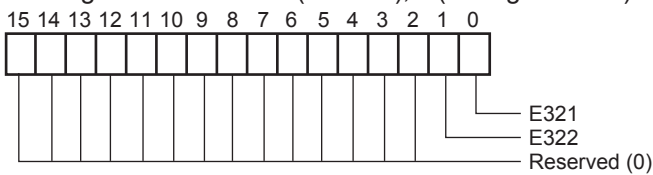

SUM: The last two digits of the total before SUM

Note: Return data when a communication error occurs



Example 2: When E205 and E301 errors are occurring,

Request command (receive data): CR2C7C_RL_F

Return data (transmit data): AR201010200000010000100000000AB_{C_RL_F}

(3) Output range switching

Output switching request command (receive data):

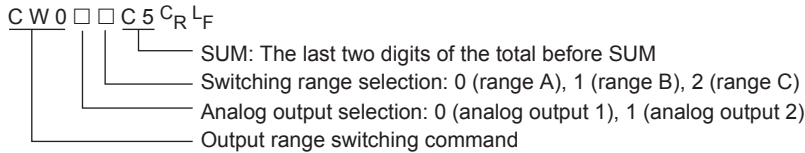

Return data (transmit data):

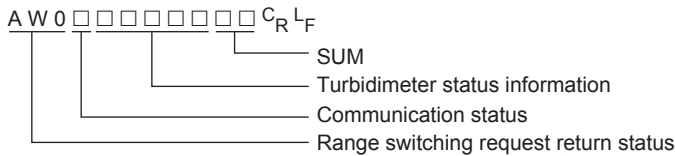

Communication status: See Note in case other than 0

0 (no communication error), 1 (parity error), 2 (framing error),

3 (overrun error), 4 (check sum error), 5 (command error)

Turbidimeter status information:

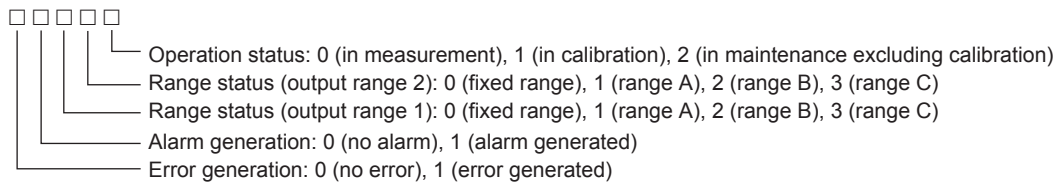

SUM: The last two digits of the total before SUM

Note: Return data when a communication error occurs



Example 3: When output range 1 is switched to range A,

Request command (receive data): CW0002A_{C_RL_F}

Return data (transmit data): AW00001000EB_{C_RL_F}

Transmission distance: RS-422: 1000 m max.

RS-232C: 10 m max.

Cable: RS-422: Twisted pair cable with shield (AWG 20 to 16)

RS-232C: Cable with shield

Contact output:

Type: Relay contact output

Number of contacts: 3

Action: On/Off

Function:

S1, S2: High/low alarm or in-maintenance selectable

FAIL: Failure

Rating: 250 VAC, 2A, 125 VA max. (resistance load) or 30 VDC, 3A, 60 W max. (resistance load), Form C (NC/NO/COM, 3 terminals)

Contact status:

Status	Contact S1, S2			Contact FAIL		
	LED	NO	NC	LED	NO	NC
In action	ON	Closed	Open	ON	Open	Closed
Not in action	OFF	Open	Closed	OFF	Closed	Open
Power OFF	OFF	Open	Closed	OFF	Open	Closed

Contact input:

Type: Voltage-free contact input
 Number of contacts: 2
 Function: Remote range switching
 On resistance: Input resistance 200Ω or less
 Off resistance: Input resistance 100 kΩ or greater
 Contact status:

Remote 2-range switching

Contact	When Range Switching is Selected	
	Range A	Range B
IN1-COM	Open	Closed

Remote 3-range switching

Contact	When Range Switching is Selected		
	Range A	Range B	Range C
IN1-COM	Open	Closed	Open
IN2-COM	Open	Open	Closed

Range contact output:

Type: Relay contact output
 Number of contacts: 3
 Action: On/Off
 Rating: 250 V AC, 2 A, 125 VA max. (resistance load) or 30 V DC, 3 A, 60 W max. (resistance load)

Contact status:

Contact	When Fixed Range is Selected	When Range Switching is Selected		
		Range A	Range B	Range C
RANGE A-COM	Open	Closed	Open	Open
RANGE B-COM	Open	Open	Closed	Open
RANGE C-COM	Open	Open	Open	Closed

Calibration:

Zero calibration: Zero water (filtered water with zero turbidity)
 Span calibration: Sensitivity calibration using check block or turbidity standard solutions
 2-point calibration: Turbidity standard solutions
 Grab sample calibration: Zero point and sensitivity correction using grab sample
 Self-diagnostics: Light source failure, input element failure, calibration failure, AD circuit failure, memory failure, etc.

Installation location: Indoor (Weather protection is required for outdoor installation)
 Ambient temperature: -5 to 50°C (Sample and tap water may need protection against freezing)

Ambient humidity: 5 to 95%RH (non-condensing)

Storage temperature: -30 to 70°C

Sample water conditions:

Flow rate: 0.05 to 20 l/min

Temperature: 0 to 50°C

Pressure: 500 kPa max.

Mounting: Pipe, wall, rack or panel mounting

Piping connection (detector):

Sample water inlet: Rc1/2 or 1/2NPT (optional)

Sample water outlet:	Rc1/2 or 1/2NPT (optional)
Drain port:	Rc1 or 1NPT (optional)
Cable inlet port (detector and converter):	DIN Pg 13.5 cable gland
Cable OD.:	6 to 12 mm
Dimensions:	
Detector:	378W x 174H x 265D mm
Converter:	144W x 144H x 142D mm
Material (main):	
Detector:	Aluminum alloy casting, modified PPE resin
Wetted parts:	Modified PPE resin, glass, fluoroc rubber, silicon rubber, SUS316
Converter:	Aluminum alloy casting, Polycarbonate resin
Construction:	JIS C 0920, IP65 Water-tight
Finish:	
Detector, Converter:	
Baked polyurethane resin coating (standard)	
Baked epoxy resin coating (optional)	
Color:	
Detector:	Spring Black (Munsell 3.3PB2.5/0.5 or equivalent), Mint green (Munsell 5.6BG3.3/2.9 or equivalent)
Converter:	Silver Gray (Munsell 3.2PB7.4/1.2 or equivalent)
Weight:	
Detector:	Approx. 5.8 kg
Converter:	Approx. 1.5 kg
Power supply:	100 to 240 VAC -15%/+10%, 50/60 Hz
Grounding:	Class D grounding
Grounding resistance of 100Ω or less	
Power consumption:	Converter + Detector: 50 VA max.
EMC Regulatory Arrangement in Australia and New Zealand:	 EN55011 Class A, Group 1
KC Marking:	Korea Electromagnetic Conformity Standard
A급 기기 (업무용 방송통신기자재)	
이 기기는 업무용(A급) 전자파적합기기로서 판매자 또는 사용자는 이 점을 주의하시기 바라며, 가정외의 지역에서 사용하는 것을 목적으로 합니다.	

2.2 Characteristics

Standard performance (under normal operating conditions)

Repeatability: $\pm 1\%$ of reading or ± 0.002 NTU, whichever is greater

Linearity: $\pm 2\%$ of reading or ± 0.01 NTU, whichever is greater

Response time: Within 2 minutes (90% response, sample water flow rate 3 l/min)

2.3 Optional Specifications

Head tank:

Simple head tank

Application: Turbidity is 10 NTU or less. To remove relatively large air bubbles.

Sample water conditions: Flow rate: 1 to 10 l/min

Turbidity: 2 to 10 NTU

Pressurized head tank for low turbidity

Application: Turbidity is 2 NTU or less. To remove air bubbles and to prevent them from occurring.

Sample water conditions: Flow rate: 0.05 to 10 l/min

Turbidity: 2 NTU or less

Pressure: 20 to 500 kPa

Transducer for ultrasonic cleaning
 (TUS400G Ultrasonic Oscillator should be purchased separately.)
 Zero turbidity filter
 When measuring range is 2.0 NTU or greater: 1 µm
 When measuring range is below 2.0 NTU: 1 µm + 0.2 µm

2.4 Model and Codes

2.4.1 TB750G Right Angle Scattered Light Turbidimeter

Model	Suffix code	Option code	Description
TB750G	-----	-----	Right angle scattered light turbidimeter
Turbidity standard and measuring range	-NTU	-----	Formazin, 0-0.2 NTU to 0-100 NTU
Application	-ST	-----	Standard
Output	-N1 -N2	-----	4 to 20 mA DC, RS-422 4 to 20 mA DC, RS-232C
Sampling system	-NN	-----	Without sampling system
Sampling system material and mounting	NN	-----	Without sampling system
Cable length between converter and detector	-1 -2 -3	-----	1 m 2 m 3 m
-	-NN	-----	Always -NN
Option	Detector process connection Mounting hardware Conduit adapter Head tank Tag plate Special painting Ultrasonic transducer	/NPT /U /R /PM /TBC /AFTG /ANSI /D1 /D2 /SCT /X1 /US	ANSI standard connection *1 Pipe mounting hardware (SUS) Rack or wall mounting hardware (SUS) Panel mounting hardware (SUS) Mounting hardware for Model 8562 or Model TB500G replacement (SUS) *2 G1/2 *3 1/2NPT *3 Pressurized head tank for low turbidity (recommended for 2.0 NTU or less) Simple head tank Stainless steel tag plate Epoxy painting *4 Transducer for ultrasonic cleaning *5

- *1: When option "/NPT" is specified, the piping connections of sample water inlet, sample water outlet, and drain port are 1/2NPT, 1/2NPT, and 1NPT respectively. Unless option "/NPT" is specified, they are Rc1/2, Rc1/2, and Rc1 respectively.
 - *2: This bracket is also available to the detector of Turbidimeter 1720E and 1720D manufactured by HACH. It is separate type, each for detector and converter.
 - *3: Conduit adapter is for power supply, output and input wiring provided by customer.
 - *4: Converter and detector case are painted with epoxy resin.
 - *5: Specify option "/US" (ultrasonic transducer) for ultrasonic cleaning. Also TUS400G Ultrasonic Oscillator should be purchased separately.
- Note: When ultrasonic cleaning is continuously used after the Model 8562 Turbidity Transmitter has been replaced with the TB750G Turbidimeter, this "/US" option must be specified.

2.4.2 Zero Turbidity Filter Assembly

Part Name	Part No.
Filter Assembly, 1µm	K9411UA
Filter Assembly, 0.2µm	K9726EF

2.4.3 Accessories

Item	Qty	Description
Lamp assembly	1	
Fuse, 3.15 A	2	3.15A
Desiccant	1	4 pcs, Part Number: K9657RJ
Silicon cloth	1	Part Number: K9210KS
Check block	1	

2.4.4 Consumables

Part Name	Part No.
Filter Element, 1 μ m	K9008ZD
Filter Element, 0.2 μ m	K9726EH
Lamp Assembly (for TB750G)	K9657PW
Fuse (3.15 A)	A1113EF
Desiccant (4 pcs) *1	K9657RJ

*1: Use within a year after purchasing.

2.4.5 Head Tank

Part Name	Part No.	Description
Pressurized head tank	K9725WA	Same as option code /D1
Simple head tank	K9658YA	Same as option code /D2

2.5 External Dimensions

2.5.1 TB750G Right Angle Scattered Light Turbidimeter

Converter

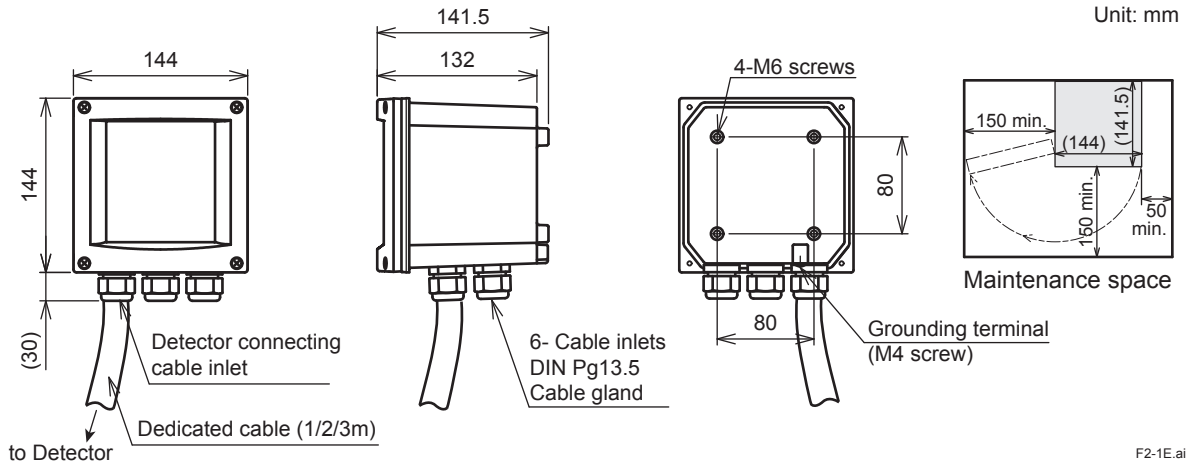

Detector

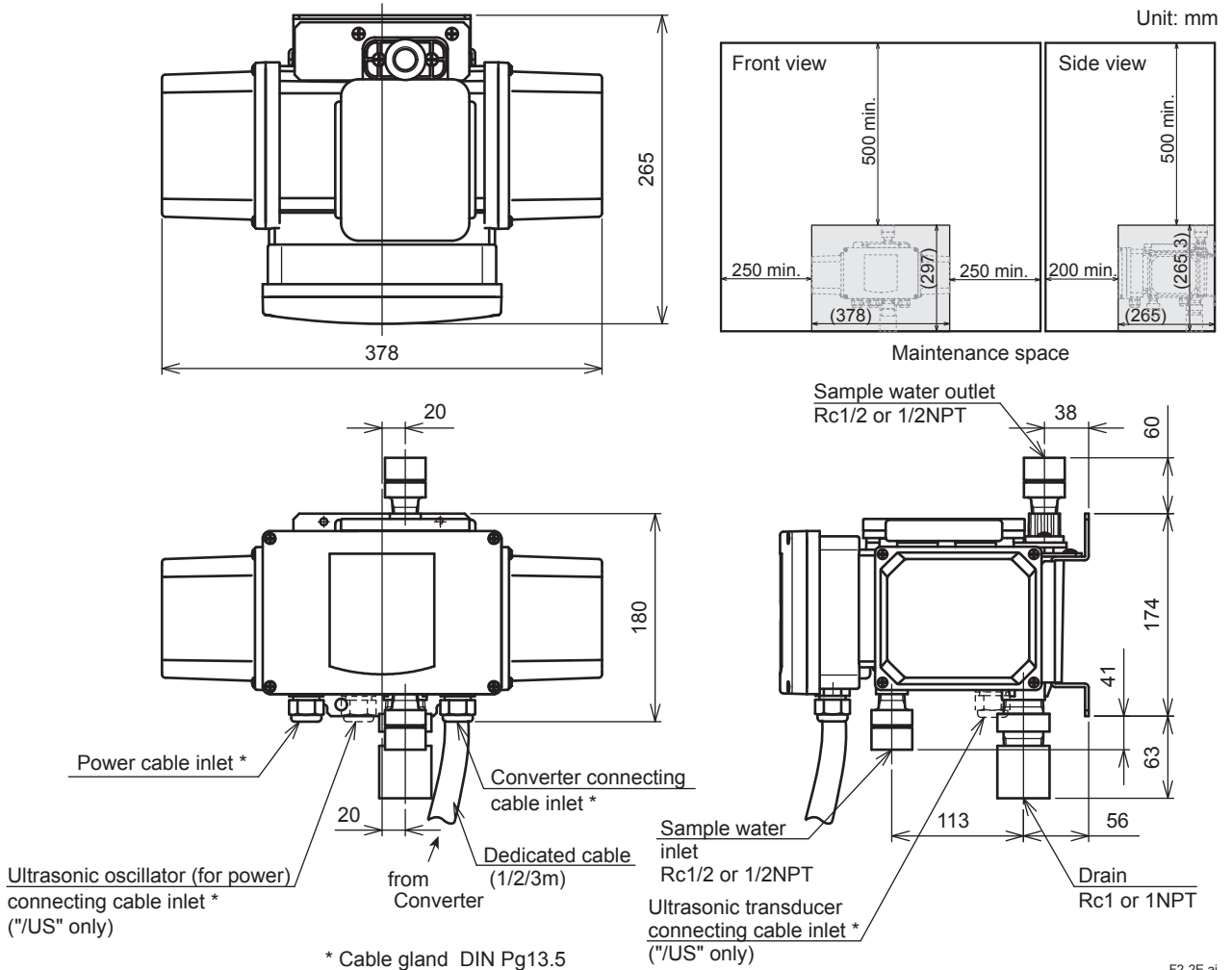

- Conduit adapter (option code: /AFTG, /ANSI)

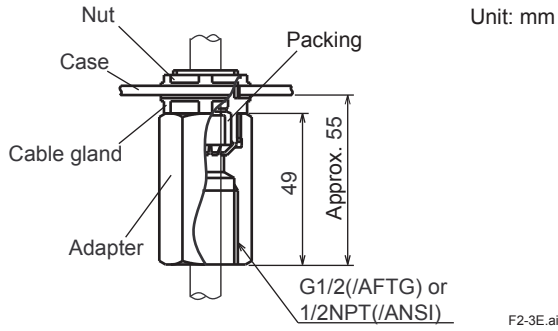

For external dimensions of mounting hardware (option code: /U, /R, /TBC) and head tank (option code: /D1, /D2), refer to Chapter 3.

2.5.2 Zero Turbidity Filter Assembly

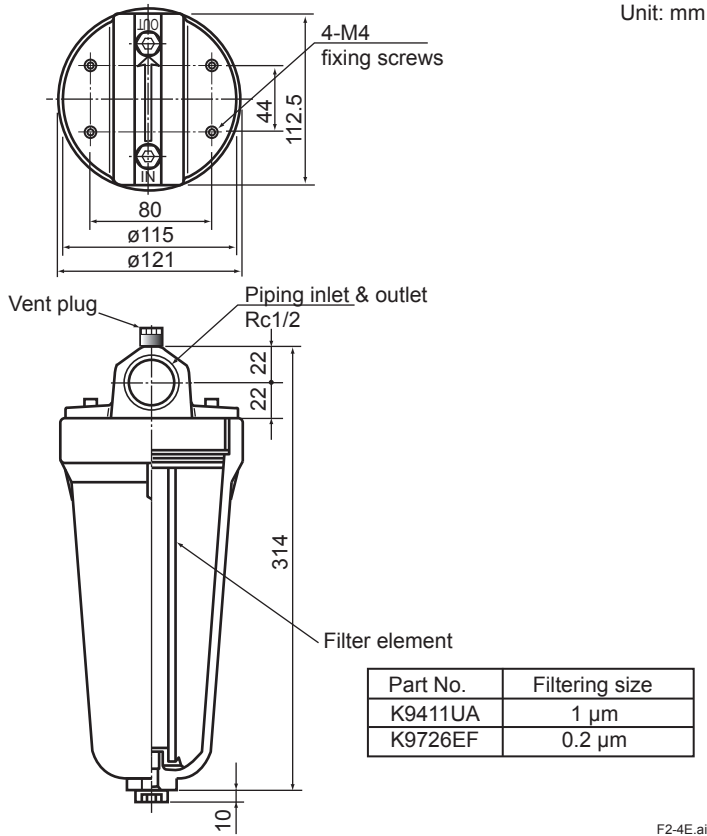

Part No.	Filtering size
K9411UA	1 μm
K9726EF	0.2 μm

2.6 Piping Diagram

The Piping diagram recommended is shown below. Refer to Section 3.3 for details.

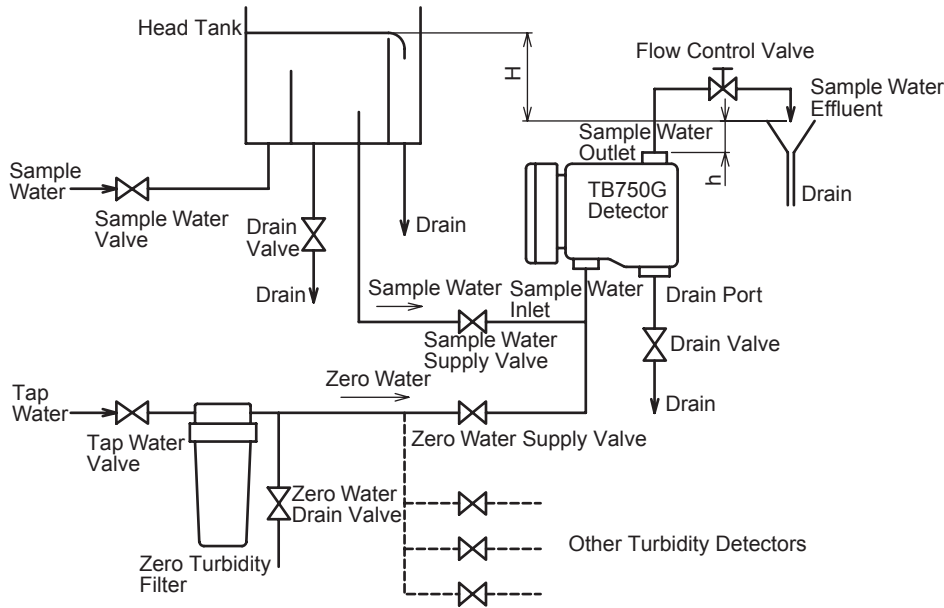

F2-5E.ai

2.7 Connection Diagram

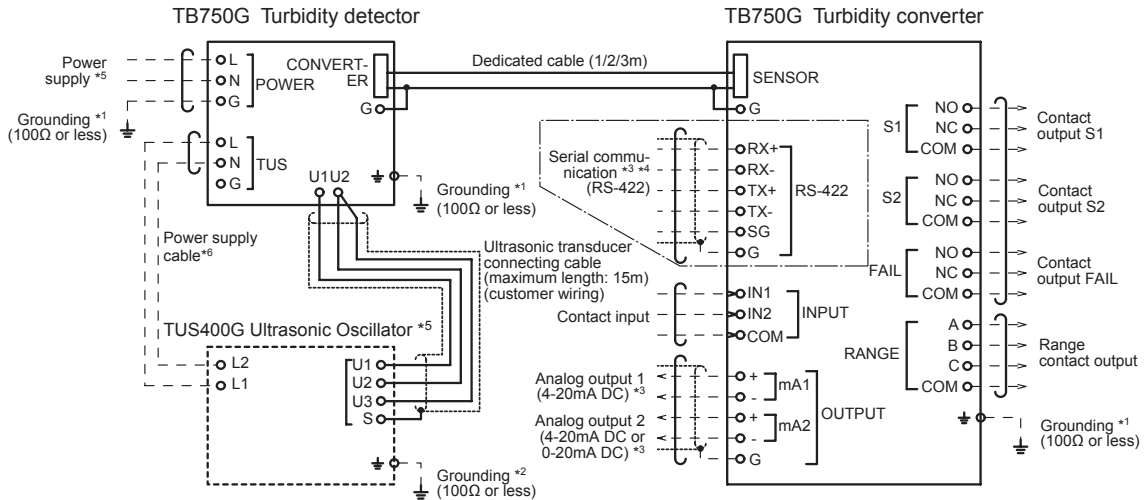

(Note) Dotted wiring is external wiring. Use cable with 6 to 12 mm OD for wiring.

*1 Power terminal "G" on detector, detector case, and converter case must be grounded (ground resistance: 100Ω or less).

*2 External grounding terminal of ultrasonic oscillator must be grounded (ground resistance: 100Ω or less).

*3 Use 2-conductor shielded cable for analog output wiring and serial communication wiring.

*4 The wiring configuration is described below in case that RS-232C serial communication is selected.

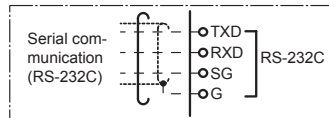

*5 When option code "/US" is specified, TUS400G should be purchased separately.

When TUS400G is used in system, the power supply to TB750G should be the same as the supply voltage specified in the MS Code of TUS400G.

*6 When "TB750G/US" and "TUS400G-NN-RC" or "TUS400G-NN-KC" is specified, refer to IM 19C1B4-01E for wiring.

F2-6E.ai

3. INSTALLATION, PIPING, AND WIRING

3.1 Installation

3.1.1 Unpacking

The TB750G turbidimeter has been carefully packed and then shipped to prevent damage during transportation. Upon receipt of the instrument, unpack with care.

3.1.2 Installation Location

The TB750G turbidimeter should be installed in a location:

- that is protected from direct sunlight and rain, i.e., the instrument should be installed indoors or in a cubicle;
- that is subject to minimal mechanical vibration;
- where no corrosive gases are present;
- that is not exposed to high temperature and humidity. The temperature should be in the range of -5 to 50°C, preferably at or around normal temperatures, and its fluctuation small. The humidity should be kept between 10 to 90%RH. Prevent condensation which may occur if the sample temperature is lower than the ambient temperature. Also, take protective measures to prevent a sample water and the tap water from freezing, if necessary;
- that provides adequate maintenance space and easy access for maintenance work;
- where the drain is provided; and,
- where the converter can be installed in the vicinity of the detector.

3.1.3 Installation Dimensions

Install the TB750G's converter and detector in pipes, racks or walls using their special mounting brackets, respectively. Note that these mounting brackets are supplied only when specified.

■ Pipe Mounting (Option Code “/U”)

Converter

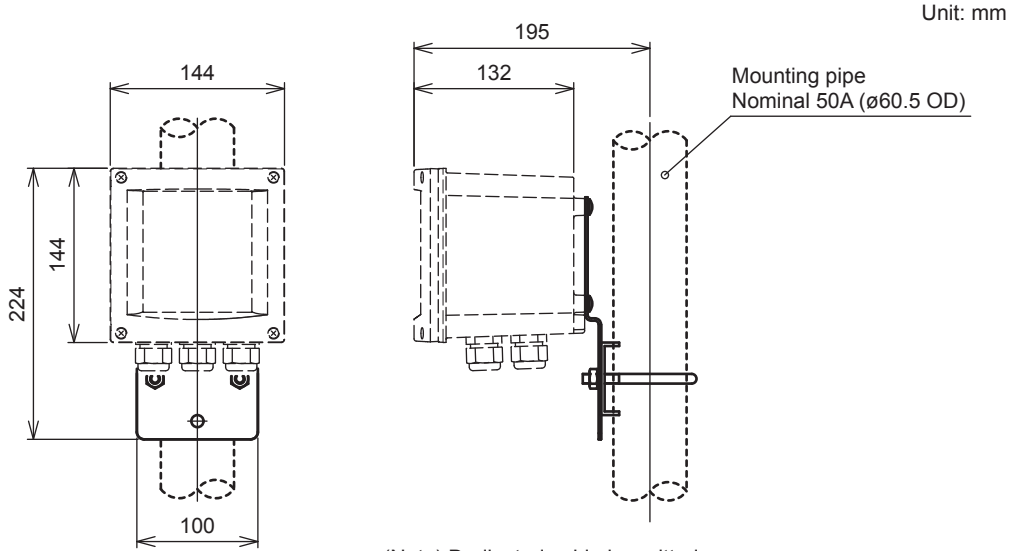

Detector

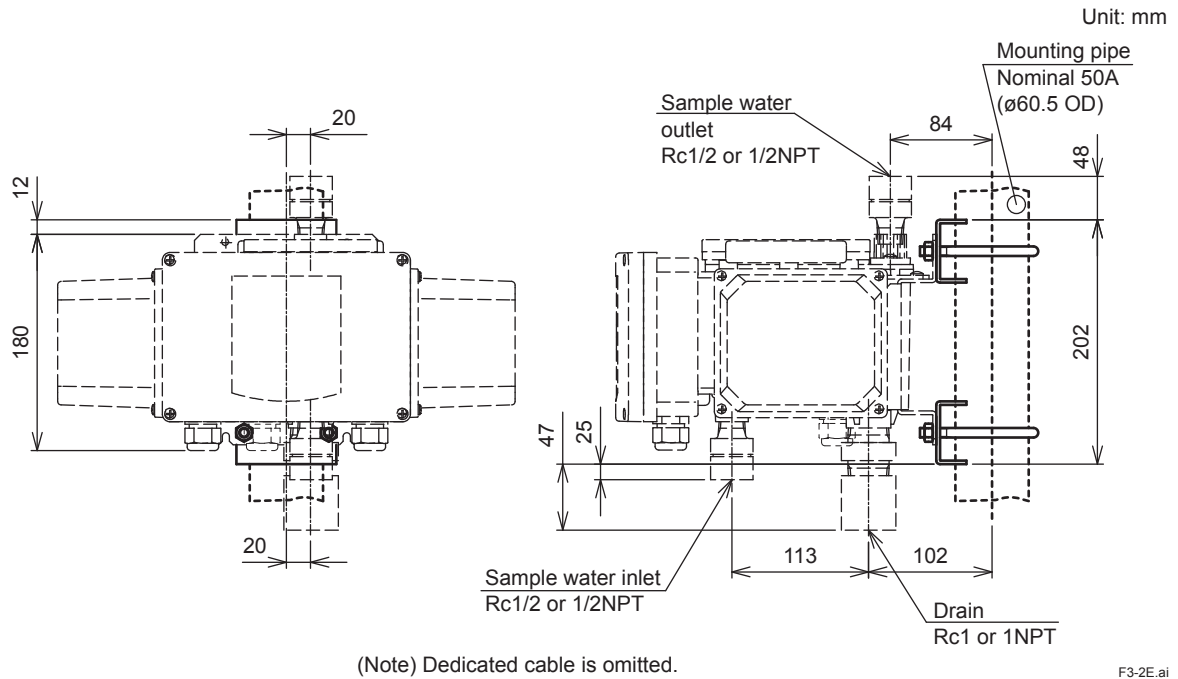

■ Rack/Wall Mounting (Option Code "R")

Converter

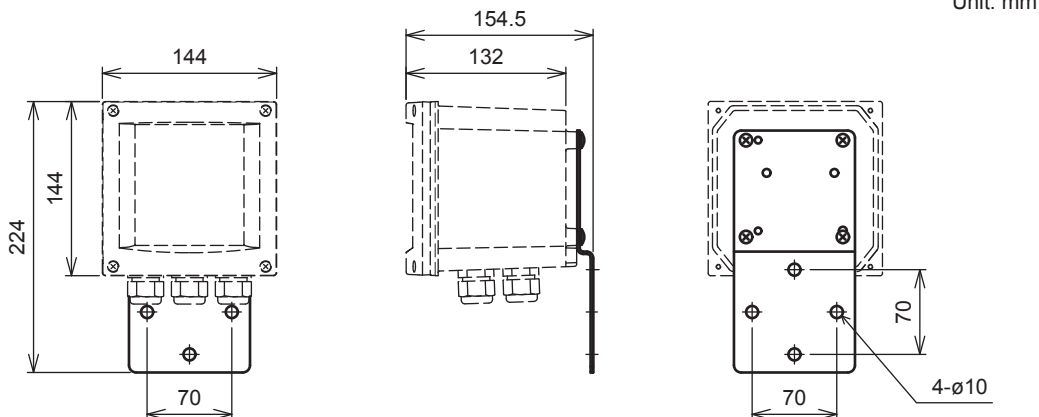

(Note) Dedicated cable is omitted.

F3-3E.ai

Detector

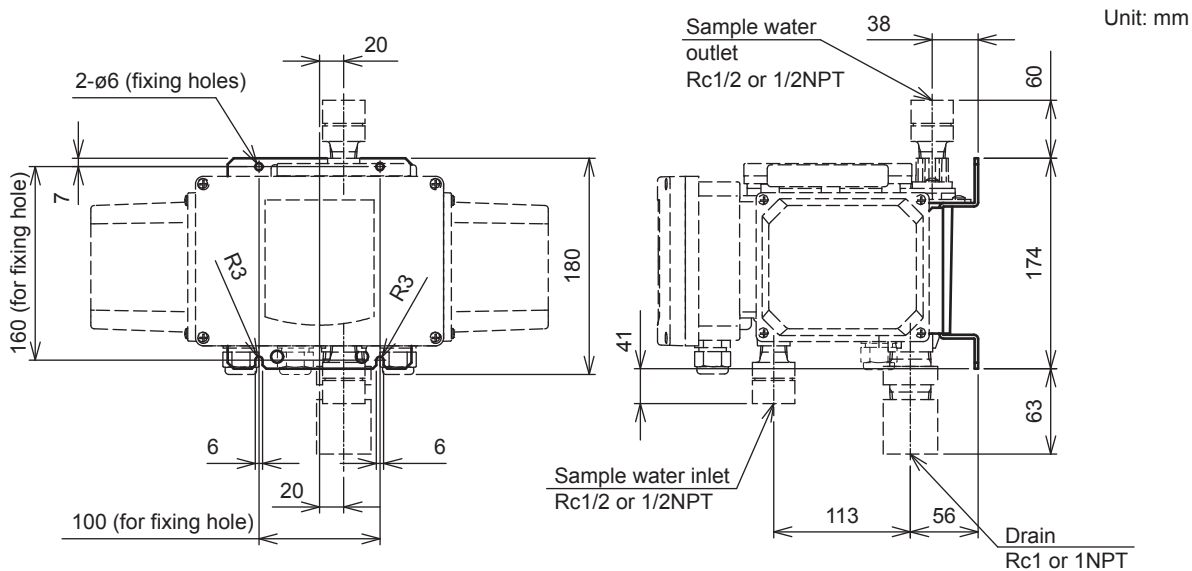

(Note) Dedicated cable is omitted.

F3-4E.ai

■ Panel Mounting (Option Code “/PM”)

Converter

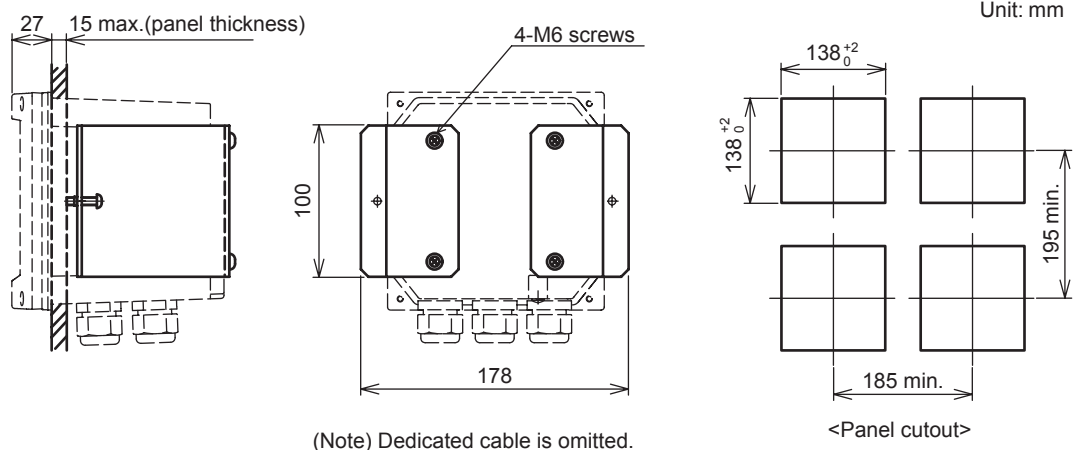

F3-5E.ai

Detector

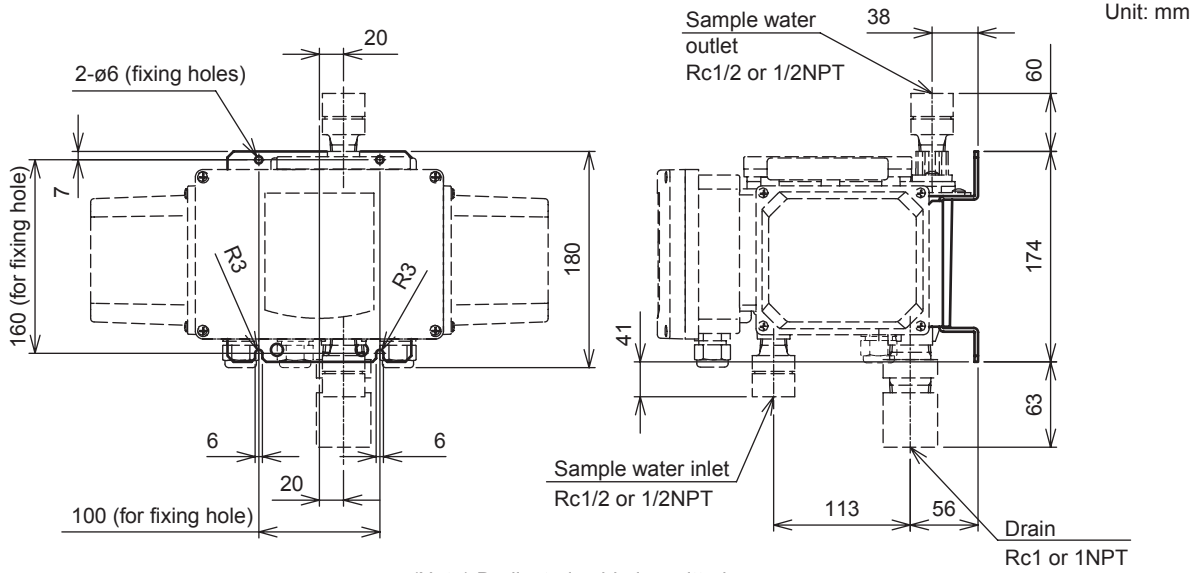

F3-6E.ai

■ Replacing Model 8562 or TB500G Detector (Option Code "/TBC")

Converter

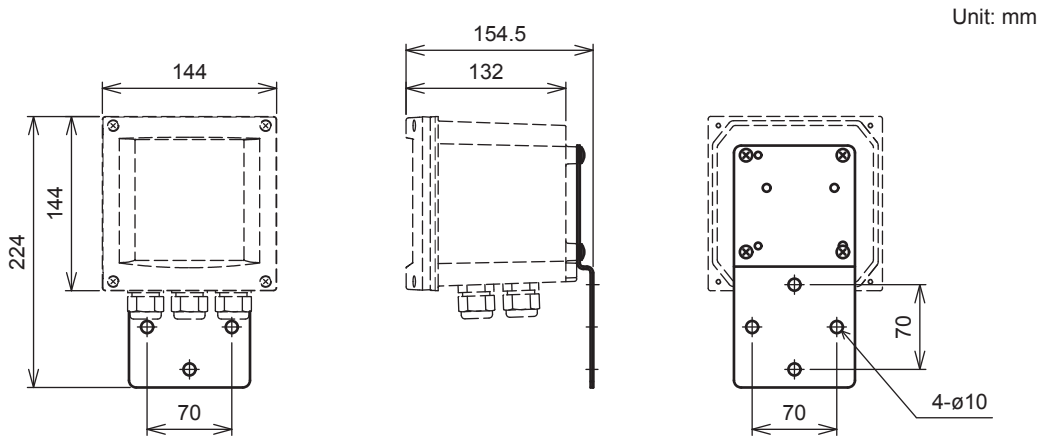

(Note) Dedicated cable is omitted.

F3-7E.ai

Detector

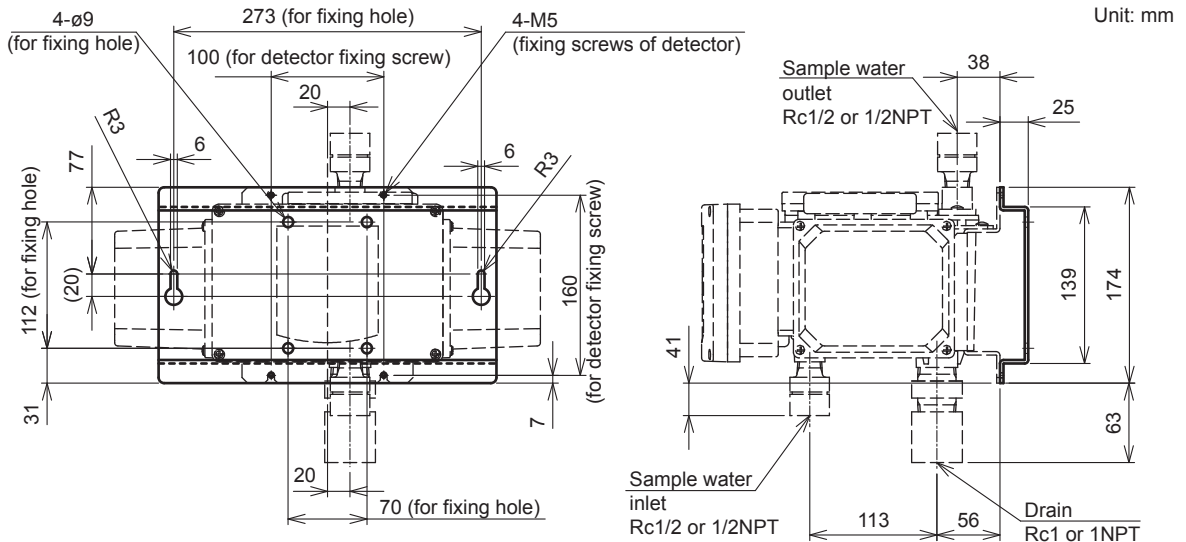

(Note) Dedicated cable is omitted.

F3-8E.ai

3.1.4 Preparation

Attaching Optional Parts

Optional parts, such as mounting brackets or conduit adapters, are supplied with the instrument when specified. To avoid misplacing any of these parts, it is recommended that they should be attached to the instrument before installation.

Preparing an Installation Site

Prepare an installation site for the TB750G so that easy operation and maintenance are allowed.

(1) Pipe Mounting

The TB750G is fixed to a stanchion (pipe) with a U-bolt. Construct a rigid pipe with an outside diameter of 60.5 mm vertically (or horizontally for converter).

(2) Wall Mounting

The TB750G converter is mounted on the wall with three M8 bolts (supplied by customer). Drill the holes in the wall as shown in Figure 3.1.

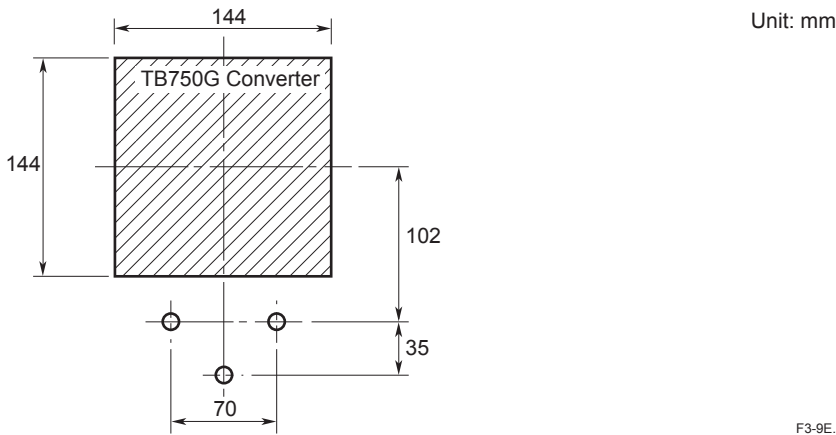

Figure 3.1 Drilling for Wall Mounting Converter

The TB750G detector is mounted on the wall with four M5 bolts (supplied by customer). Drill the holes in the wall as shown in Figure 3.2.

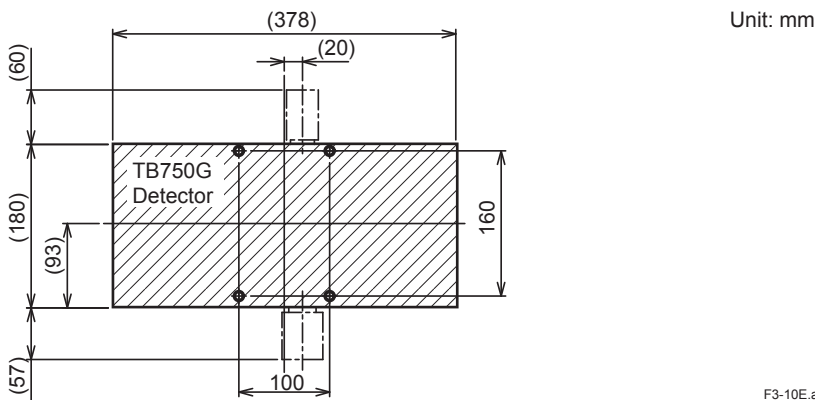
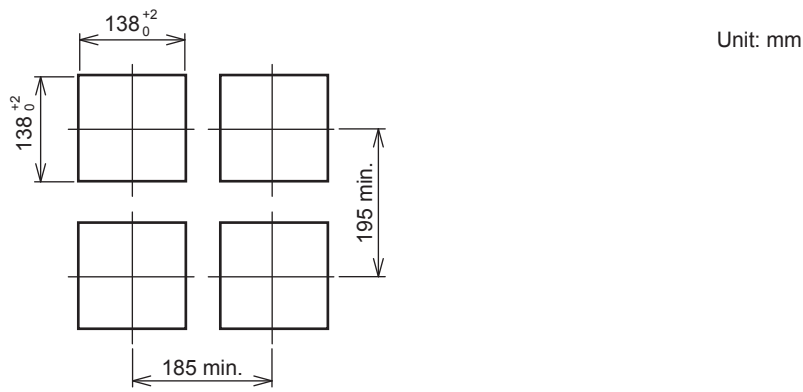

Figure 3.2 Drilling for Wall Mounting Detector

(3) Panel Mounting

In the mounting position of the TB750G converter, make a panel cutout as shown in Figure 3.3. The thickness of a panel should not exceed 15 mm.



F3-11E.ai

Figure 3.3 Cutout for Converter's Panel Mounting

As with (2) Wall Mounting, the TB750G detector is mounted on a panel with four M5 bolts (supplied by customer). Drill the holes in the panel as shown in Figure 3.2.

3.1.5 Mounting the Converter and Detector

(1) Pipe Mounting

Figures 3.4 and 3.5 show the pipe mounting brackets and the mounting procedures.

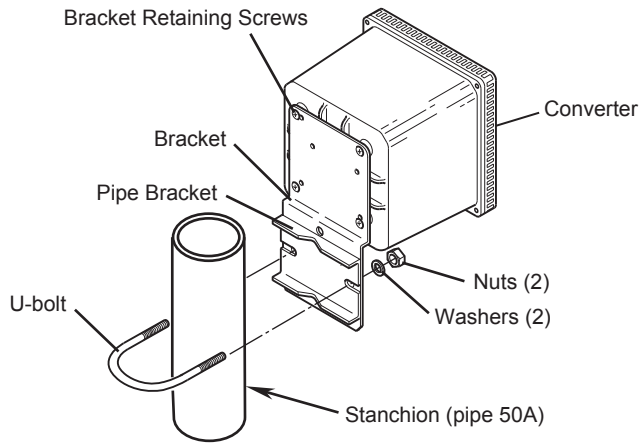

F3-12E.ai

Figure 3.4 Pipe Mounting, Converter

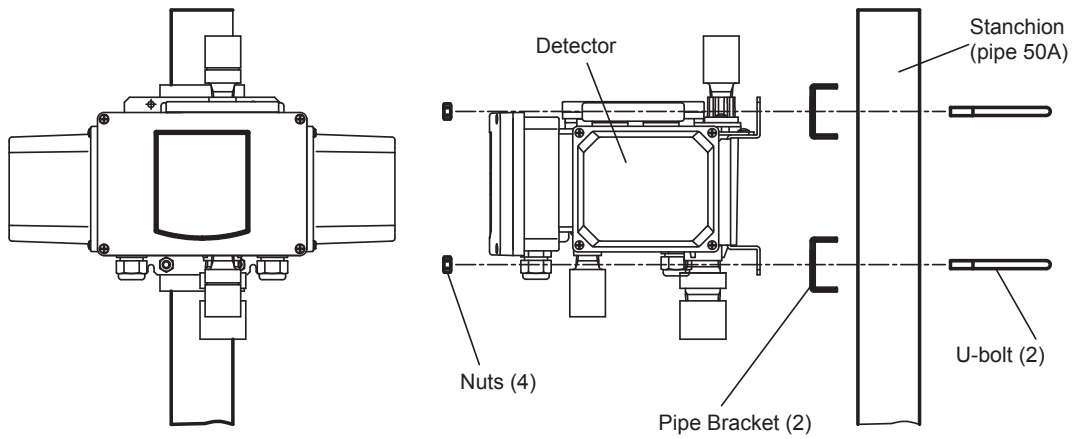

F3-13E.ai

Figure 3.5 Pipe Mounting, Detector

(2) Wall Mounting

Figures 3.6 and 3.7 show the wall mounting procedures.

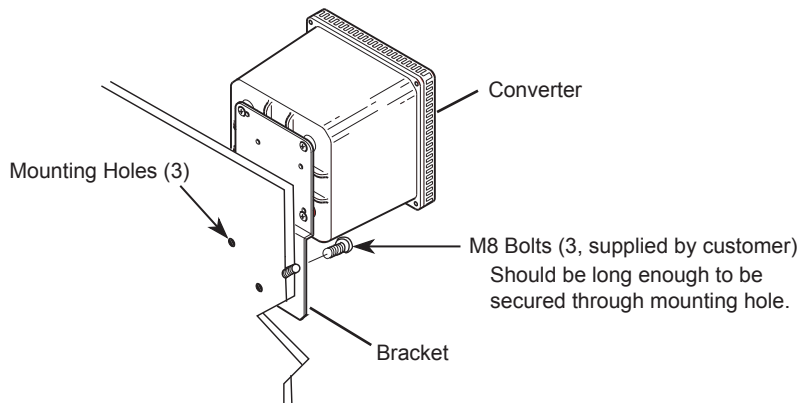

F3-14E.ai

Figure 3.6 Wall Mounting, Converter

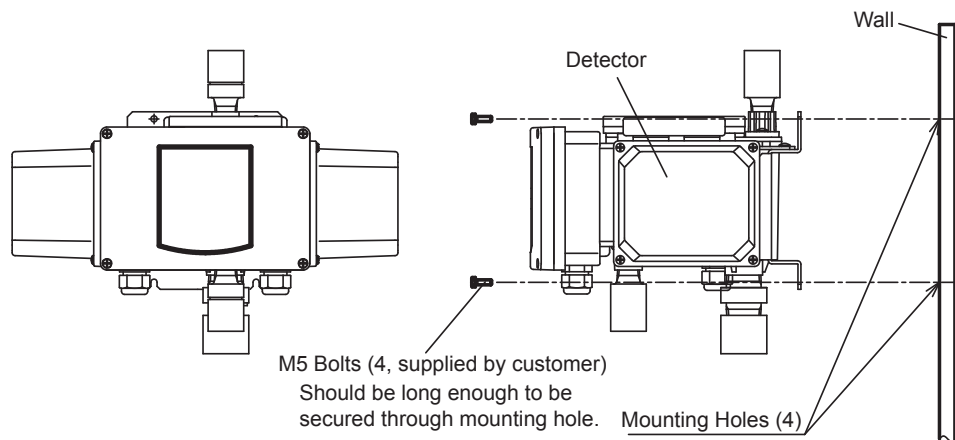

F3-15E.ai

Figure 3.7 Wall Mounting, Detector

(3) Panel Mounting

Figure 3.8 shows the panel mounting procedure for the converter.

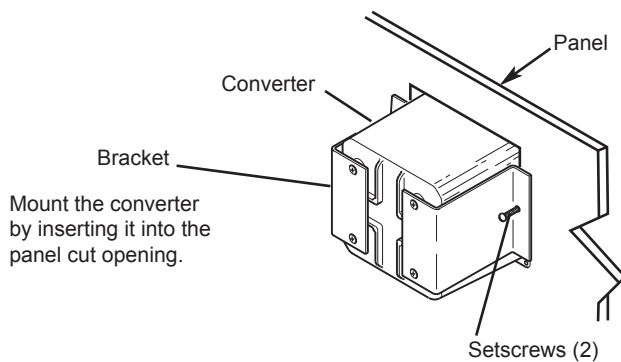

F3-16E.ai

Figure 3.8 Panel Mounting, Converter

The procedure for detector's panel mounting is the same as the one for its wall mounting. See Figure 3.7.

Depending on the installation position, the converter-detector connecting cable may need to be disconnected once. In that case, disconnect the cable end from the converter by following the instructions below.

< How to Disconnect the Converter-Detector Connecting Cable >

(a) Connector

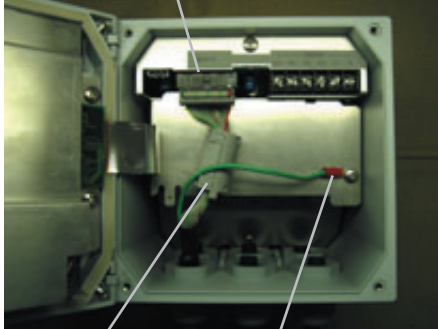

(c) Ferrite Core (b) Grounding Wire

1. Open the front cover of the converter.
Next, remove the following.

- (a) Connector
- (b) Grounding wire
- (c) Ferrite core

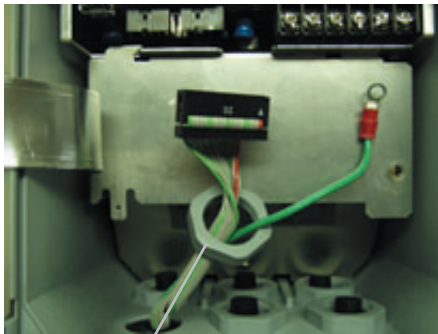

Cable Gland's Ring

2. Loosen the cable gland and pull out the cable gland's ring that is attached to the inside of the cable inlet port on the converter.

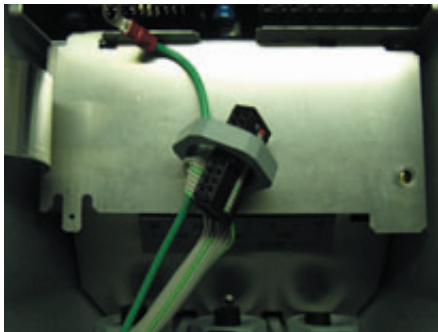

3. Slide the ring over the cable, the connector and the wire until it comes off. Orient the connector as shown in the picture to the left so that it goes through the ring.



4. Remove the cable and the wire from the converter by carefully pulling them out through the port.
To reconnect the cable to the converter, reverse the above steps.

Note: Remove all cable glands before inserting the converter into the panel cut opening.

F3-17E.ai

3.2 Wiring

3.2.1 Wiring Required for the TB750G

Wiring for the Converter

- (1) Analog output wiring
- (2) Contact input (remote range switching) wiring
- (3) Range contact output wiring
- (4) Contact output (S1, S2 and FAIL) wiring
- (5) Serial communication wiring
- (6) Checking wiring to the detector
- (7) External ground wiring

Wiring for the Detector

- (8) Power and ground wiring
- (9) External ground wiring
- (10) Power wiring for ultrasonic oscillator (when option code "/US" is specified)
- (11) Wiring to ultrasonic transducer (when option code "/US" is specified)



CAUTION

Before opening the front cover of the converter or the detector, turn off power to the TB750G turbidimeter. Make sure that the turbidimeter is not powered before wiring work. Do not touch terminals while the turbidimeter is being powered.



NOTE

The TB750G turbidimeter does not have an internal power switch. Be sure to provide a switch (double pole type, compliant with IEC 60947-1 and IEC 60947-3) in the power line as close to the instrument as possible. The "I" (on) and "O" (off) symbols should be indicated near the switch if they are not indicated on the switch.

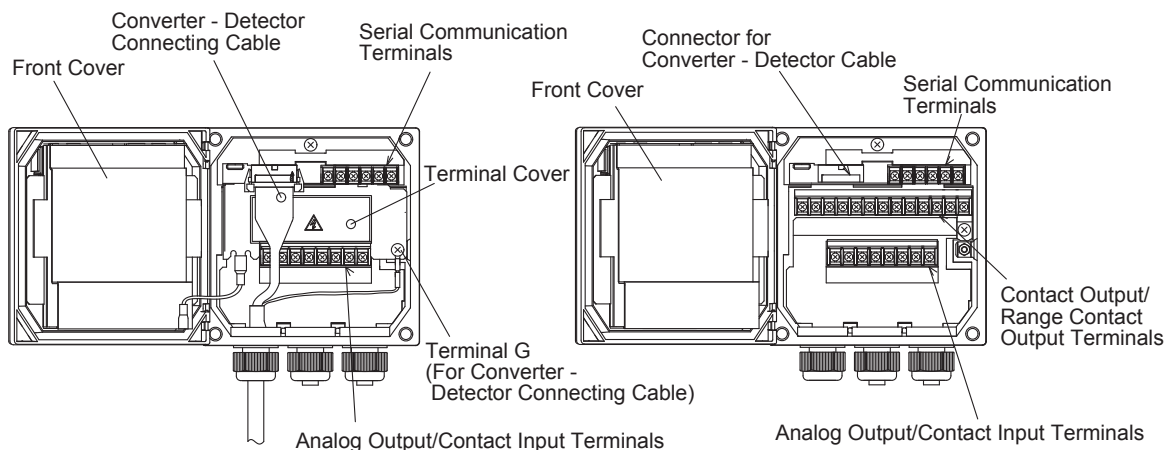
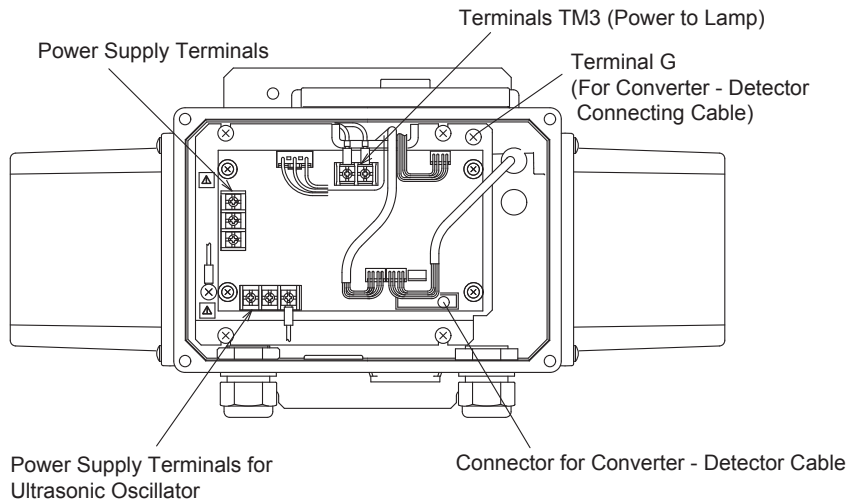

Figure 3.9 Internal View of the Converter

F3-18E.ai



F3-19E.ai

Figure 3.10 Internal View of the Detector

[Procedure for Wiring]

Procedure for Wiring to the Converter

Before wiring work, make sure that the power supply is disconnected from the TB750G converter. Remove the front cover by loosening the 4 setscrews holding the cover to the converter. Remove the terminal cover and also remove the grounding terminals of both the converter and the detector. Then, make the following wiring connections.

- (1) Analog output wiring
- (2) Contact input (remote range switching) wiring
- (3) Range contact output wiring
- (4) Contact output (S1, S2 and FAIL) wiring

Attach the terminal cover and also replace the grounding terminals of both the converter and the detector. Then, make the following wiring connection.

- (5) Serial communication wiring
- (6) Checking wiring to the detector
- (7) External ground wiring

Close the converter's front cover and tighten the 4 setscrews to fix the cover.

Procedure for Wiring to the Detector

Before wiring work, make sure that the power supply is disconnected from the TB750G turbidimeter. Remove the front cover by loosening the 4 setscrews holding the cover to the detector.

- (8) Power and ground wiring
- (9) External ground wiring
- (10) Power wiring for ultrasonic oscillator (when option code "/US" is specified)

Replace the front cover and tighten the 4 setscrews. Then, remove the left side cover on the detector by loosening the 4 setscrews holding the cover to the detector.

- (11) Wiring to ultrasonic transducer (when option code "/US" is specified)

Replace the side cover and tighten the 4 setscrews.

3.2.2 Cable Inlet Port

The TB750G converter has 6 cable inlet ports and the detector has 3 cable inlet ports. A cable gland corresponding to the cable with an outside diameter of 6 to 12 mm, is attached to each cable inlet port. Run each cable through the specified ports as shown in Figures 3.11 and 3.12. Unused cable inlet ports, if any, should be plugged to prevent dust or foreign matter from entering.

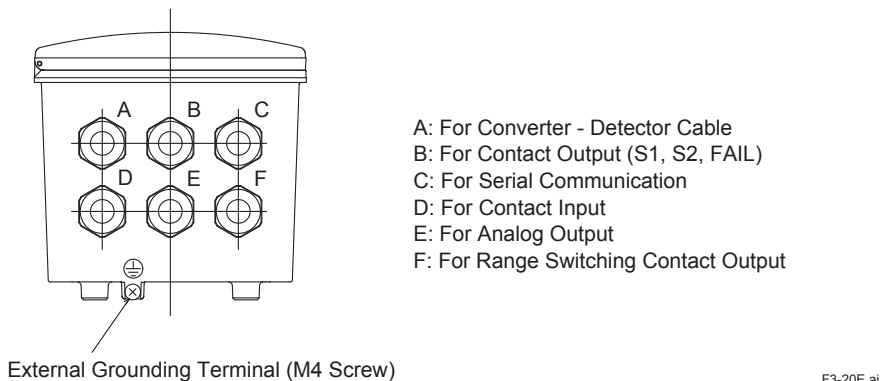

Figure 3.11 Cable Inlet Ports of the Converter

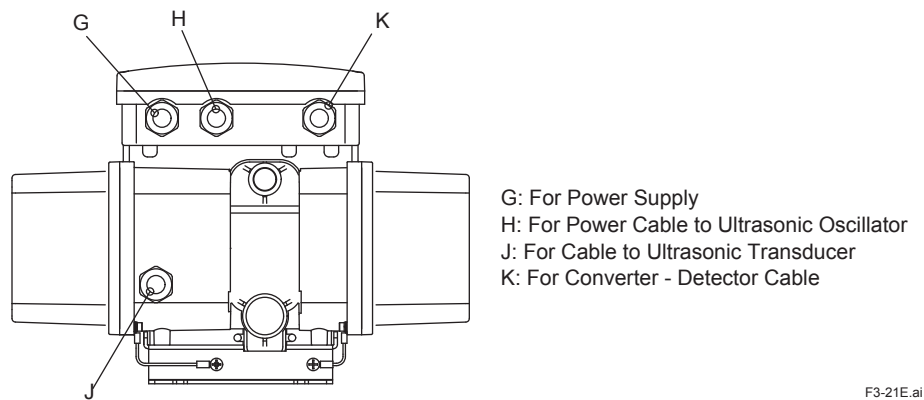

Figure 3.12 Cable Inlet Ports of the Detector

When conduits are used to protect cables, use adapters: six pieces are supplied when option code "/AFTG" is specified). Remove cable glands from cable inlet ports B, C, D, E, and F, and attach adapters and cable glands as shown in Figure 3.13.

No conduit work is done with cable inlet port A, a port for a cable connecting the converter and the detector. Use the cable glands originally attached to the port.

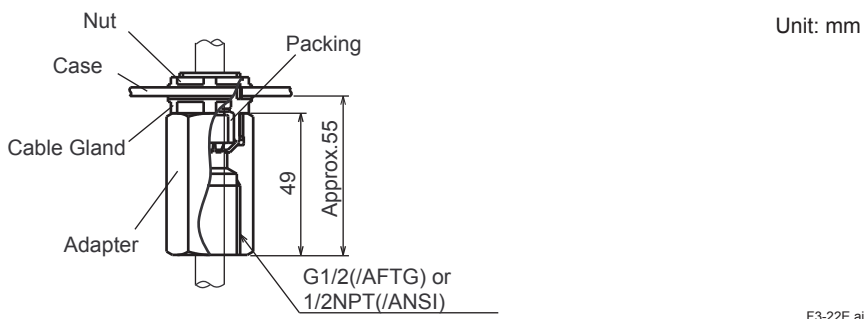

Figure 3.13 Conduit Adapter

3.2.3 Analog Output Wiring

This wiring is for transmitting an output signal of the converter to a receiver such as a recorder. Two outputs are available: output 1 (4-20 mA DC) and output 2 (4-20 or 0-20 mA DC).



CAUTION

Before opening the front cover of the converter or the detector, turn off power to the TB750G turbidimeter. Make sure that the turbidimeter is not powered before wiring work. Do not touch terminals while the turbidimeter is being powered.

[Cable Required]

Use a shielded cable with a finished outside diameter of 6 to 12 mm. The number of conductors is determined by that of signals: 2 or 4 conductors.

[Procedure]

(1) Terminating the cable.

Strip off approximately 40 mm of the insulation from the end of the cable. Cut off the exposed shield as short as possible and solder a lead wire for grounding (with approximately the same length as the conductor) to the remaining exposed shield. Wrap the soldered area with an insulating tape or relevant protection.

Then, terminate the ends of the lead wire and the conductors with crimp terminals corresponding to the M3 screw.

(2) Connecting the cable to the converter.

Connect the lead wire and the conductors of the cable to the specified terminals on the converter.

Output 1 (mA1):	Terminals (+) and (-)
Output 2 (mA2):	Terminals (+) and (-)
Grounding wire:	Terminal G



NOTE

The shield of the cable should be grounded only at the converter side. Leave the receiver end of the shield disconnected.

To run the cable through the cable gland, remove the assembled parts from the cable gland body at cable inlet port E and then slide these parts over the cable in order.

(3) Fixing the cable

Adjust the cable length housed in the converter and fix the cable by mounting the parts to the cable gland body.

3.2.4 Contact Input (Remote Range Switching) Wiring

Either of analog outputs can be used for range switching, for which any of manual (local) range switching, auto-range switching, remote 2-range switching, or remote 3-range switching can be selected. This wiring should be made when remote 2- range or 3-range switching is selected.

Contact input on-off signals are distinguished by resistance conditions shown in Table 3.1. Before wiring, ensure that the contacts meeting the conditions are used.

Table 3.1 On-Off Conditions of Contact Input for Remote Range Switching

	On Condition	Off Condition
Resistance (contact)	$\leq 200 \Omega$	$\geq 100 \text{ k}\Omega$

The contact input (for remote range switching) is turned on and off between terminals IN1 and COM and between terminals IN2 and COM.

The relationship between on-off contact input and output range is shown in Table 3.2.

Table 3.2 Contact Input and Output Range

• 2-Range Switching

Contact	When Range Switching is Selected	
	Range A	Range B
IN1-COM	Open	Closed

• 3-Range Switching

Contact	When Range Switching is Selected		
	Range A	Range B	Range C
IN1-COM	Open	Closed	Open
IN2-COM	Open	Open	Closed

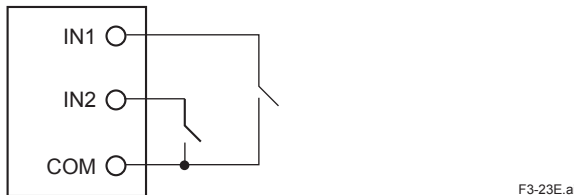

Figure 3.14 Contact Input for Remote Range Switching

[Cable Required]

Use a 2-conductor cable with a finished outside diameter of 6 to 12 mm.

[Procedure]

(1) Terminating the cable.

Strip off approximately 40 mm of the insulation from the end of the cable. Terminate the ends of each conductor with crimp terminals corresponding to the M3 screw.

(2) Connecting the cable to the converter.

Connect the conductors of the cable to the specified terminals on the converter.

Contact Input (INPUT): Terminals IN1, IN2 and COM

To run the cable through the cable gland, remove the assembled parts from the cable gland body at cable inlet port D and then slide these parts over the cable in order.

(3) Fixing the cable.

Adjust the cable length housed in the converter and fix the cable by mounting the parts to the cable gland body.

3.2.5 Contact Output (S1, S2 and FAIL) Wiring

This wiring is for releasing contact outputs S1 and S2 as the contacts for high/low alarms and maintenance, and for releasing contact output FAIL when an abnormality is detected. The rating and operation of the contact output relays are provided in Tables 3.3 and 3.4, respectively.

Table 3.3 Contact Rating

	AC	DC
Contact maximum permissible voltage	250 V	30 V
Contact maximum permissible current	2 A	3 A
Contact maximum permissible power (resistance load)	125 VA	60 W

Table 3.4 Contact Operation

Status	Contact S1, S2			Contact FAIL		
	LED	NO	NC	LED	NO	NC
In action	ON	Closed	Open	ON	Open	Closed
Not in action	OFF	Open	Closed	OFF	Closed	Open
Power OFF	OFF	Open	Closed	OFF	Open	Closed

Be sure to use the contacts meeting the conditions above.



CAUTION

Before opening the front cover of the converter for wiring work, be sure to turn off power to the TB750G turbidimeter. Do not touch terminals while the turbidimeter is being powered.

- If the contact capacity exceeds the rating (see Table 3.3), use an auxiliary relay to turn on and off the load.
- The contact relay has a limited life. If inductance (L) load such as an auxiliary relay or solenoid valve is used, a CR filter (for AC relay) or diode (for DC relay) must be inserted in parallel as a surge suppressor circuit for eliminating sparks. Otherwise, malfunction or relay failure may result.

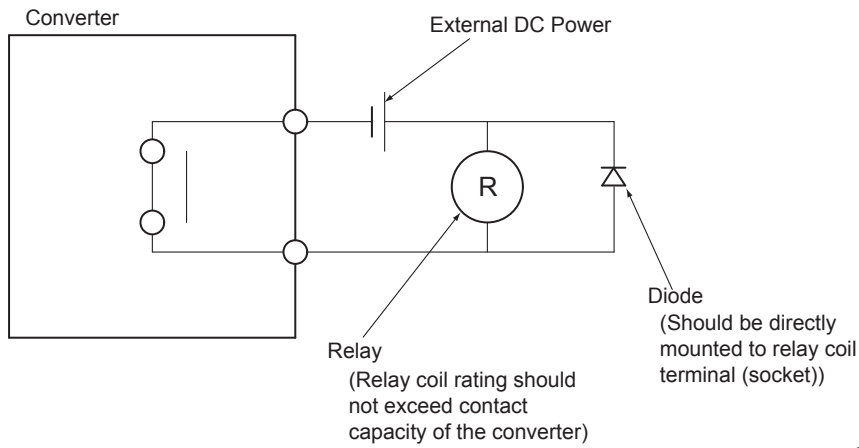

F3-24E.ai

Figure 3.15 Inserting Diode for DC Relay

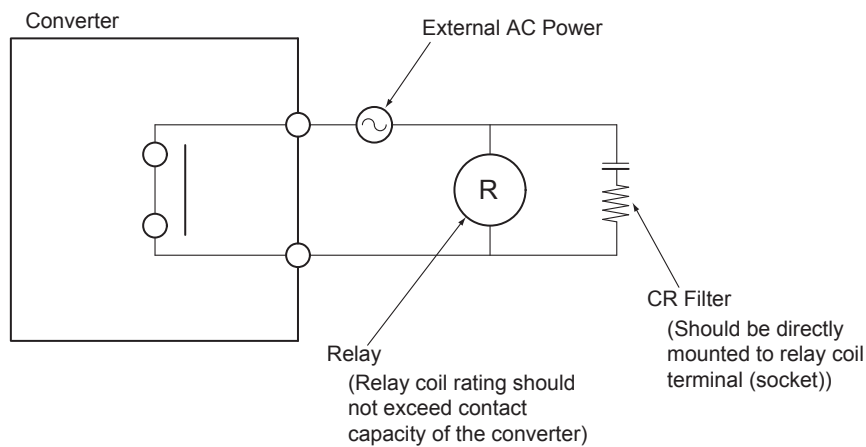

F3-25E.ai

Figure 3.16 Inserting CR Filter for AC Relay

[Cable Required]

Use a cable with a finished outside diameter of 6 to 12 mm. The number of conductors is determined by that of signals: 2 or 4 conductors.

[Procedure]

- (1) Terminating the cable.
Strip off approximately 40 mm of the insulation from the end of the cable. Terminate the ends of each conductor with crimp terminals corresponding to the M3 screw.
- (2) Connecting the cable to the converter.
Connect the conductors of the cable to the specified terminals on the converter. To run the cable through the cable gland, remove the assembled parts from the cable gland body at cable inlet port B and then slide these parts over the cable in order.
- (3) Fixing the cable.
Adjust the cable length housed in the converter and fix the cable by mounting the parts to the cable gland body.

3.2.6 Range Contact Output Wiring

As analog output range, three types of ranges can be configured and switched. This wiring should be made when using the range contact output.

The rating and operation of the range contact output relays are provided in Tables 3.5 and 3.6, respectively.

Table 3.5 Contact Rating

	AC	DC
Contact maximum permissible voltage	250 V	30 V
Contact maximum permissible current	2 A	3 A
Contact maximum permissible power (resistance load)	125 VA	60 W

Table 3.6 Contact Operation

Contact	When Fixed Range is Selected	When Range Switching is Selected		
		Range A	Range B	Range C
RANGE A-COM	Open	Closed	Open	Open
RANGE B-COM	Open	Open	Closed	Open
RANGE C-COM	Open	Open	Open	Closed

[Cable Required]

Use a 2-conductor cable with a finished outside diameter of 6 to 12 mm.

[Procedure]

- (1) Terminating the cable.

Strip off approximately 40 mm of the insulation from the end of the cable. Terminate the ends of each conductor with crimp terminals corresponding to the M3 screws.

- (2) Connecting the cable to the converter.

Connect the conductors of the cable to the specified terminals on the converter.

Range contact output (RANGE): Terminals A, B, C, and COM

To run the cable through the cable gland, remove the assembled parts from the cable gland body at cable inlet port F and then slide these parts over the cable in order.

- (3) Fixing the cable.

Adjust the cable length housed in the converter and fix the cable by mounting the parts to the cable gland body.



CAUTION

Before opening the front cover of the converter or the detector, turn off power to the TB750G turbidimeter. Make sure that the turbidimeter is not powered before wiring work. Do not touch terminals while the turbidimeter is being powered.

3.2.7 Serial Communication Wiring

This wiring is for the serial communication (RS-422 or RS-232C) of the turbidity, status, error details and other information. For details on specifications and transmission, see Section 2.1, “Standard Specifications.”

[Cable Required]

- RS-422: Twisted pair cable with shield (AWG 20 to 16), 1000 m max.
- RS-232C: Cable with shield, 10 m max.

[Procedure]

- (1) Terminating the cable.
 - Strip off approximately 40 mm of the insulation from the end of the cable. Solder a lead wire to the exposed shield at its root. Wrap the soldered area with an insulating tape or relevant protection. Cut the attached lead wire so that it has approximately the same length as the conductor. Terminate the ends of the lead wire and the conductors with crimp terminals corresponding the M4 screw.
 - (2) Connecting the cable to the converter.
 - For RS-422 communication
 - Serial communication (RS-422): Terminals RX+, RX-, TX+, TX-, SG and G
 - For RS-232C communication
 - Serial communication (RS-232C): Terminals TXD, RXD, SG and G
- For the connection to the receiver, see Figure 3.17.



CAUTION

The shield of the cable should be grounded only at the converter side. Leave the receiver end of the shield disconnected.

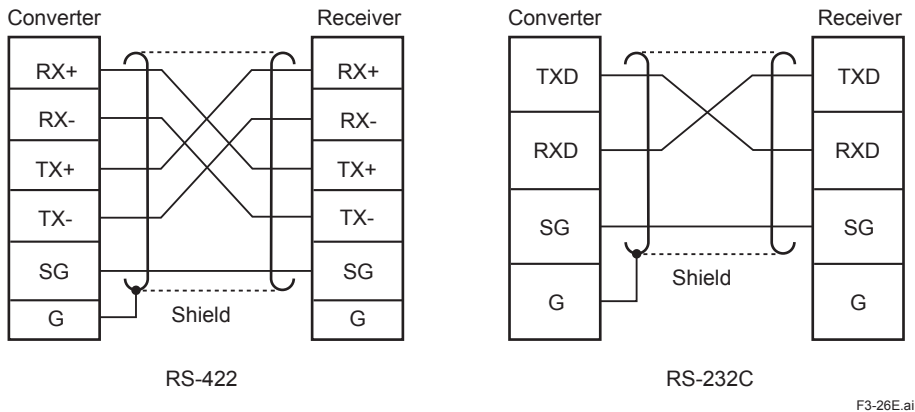

Figure 3.17 Serial Communication Wiring Diagram

3.2.8 Checking Wiring between the Converter and the Detector

A dedicated cable has been connected between the converter and the detector before shipment. Ensure that the cable is securely connected to terminals, SENSOR and G, on the converter. If the cable is disconnected from these terminals during the converter wiring work, reconnect it.

3.2.9 Power and Ground Wiring

The power wiring is for supplying a voltage of 85 to 264 V AC with a frequency of 50/60 Hz to the TB750G detector. Use a power supply where the voltage does not fluctuate outside the operating range.

The ground wiring is for grounding the grounded circuit inside the detector. Ground wiring should be connected to terminal G in the converter and grounded at the power supply side with JIS Class D grounding (ground resistance 100 Ω or less).



CAUTION

Before opening the front cover of the converter or the detector, turn off power to the TB750G turbidimeter. Make sure that the turbidimeter is not powered before wiring work. Do not touch terminals while the turbidimeter is being powered.



NOTE

The TB750G Right Angle Scattered Light Turbidimeter does not have an internal power switch. Be sure to provide a switch (double pole type, compliant with IEC 60947-1 and IEC 60947-3) in the power line as close to the instrument as possible. The "I" (on) and "O" (off) symbols should be indicated near the switch if they are not indicated on the switch.

[Cable Required]

Use a 3-conductor cable with a nominal size of at least 2 mm² and a finished outside diameter of 6 to 12 mm or 2-conductor shielded cable. The cable performance should also be equivalent to or exceeds that of a 600 V vinyl insulated wire (JIS C3307).

[Procedure]

- (1) Terminating the cable.
Strip off approximately 40 mm of insulation from the end of the cable. Terminate the ends of each conductor with crimp terminals corresponding to the M4 screw.
- (2) Connecting the cable to the detector.
Remove the terminal cover. Connect each conductor to terminals L, N and G on the detector.
Replace the terminal cover.
To run the cable through the cable gland, remove the assembled parts from the cable gland body at cable inlet port G and then slide these parts over the cable in order.
- (3) Fixing the cable.
Adjust the cable length housed in the detector and fix the cable by mounting the parts to the cable gland body.
- (4) Grounding.
The grounding wire (G) of the cable should be grounded at the power supply side with JIS Class D grounding (ground resistance 100 Ω or less).

3.2.10 External Ground Wiring for the Converter

The grounding terminal of the converter is located at the bottom of the back side as shown in Figure 3.18.

Ground the terminal with JIS Class D grounding (ground resistance 100 Ω or less) using a wire with a nominal size of at least 2 mm². The terminal screw size is M4. Attach a corresponding crimp terminal to the end of the wire.

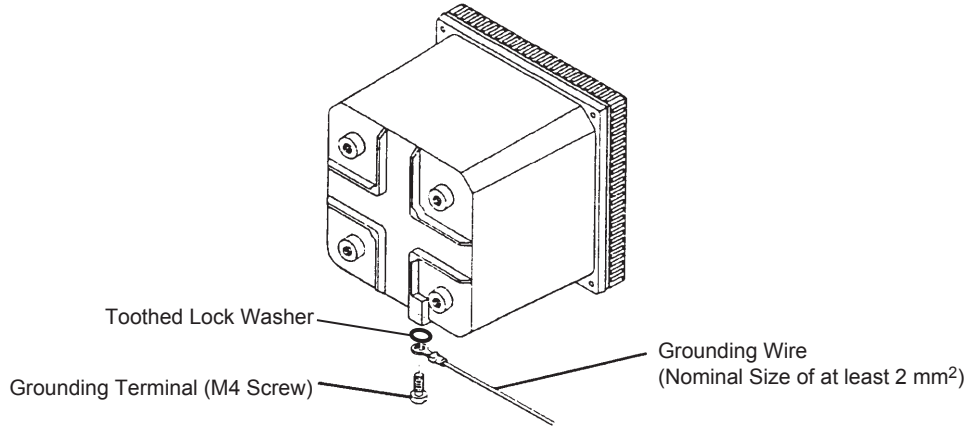

F3-27E.ai

Figure 3.18 Grounding Terminal

3.2.11 External Ground Wiring for the Detector

The grounding terminal of the detector is located at the top of the back side as shown in Figure 3.19.

Ground the terminal with JIS Class D grounding (ground resistance 100 Ω or less) using a wire with a nominal size of at least 2 mm². The terminal screw is M5. Attach a corresponding crimp terminal to the end of the wire.

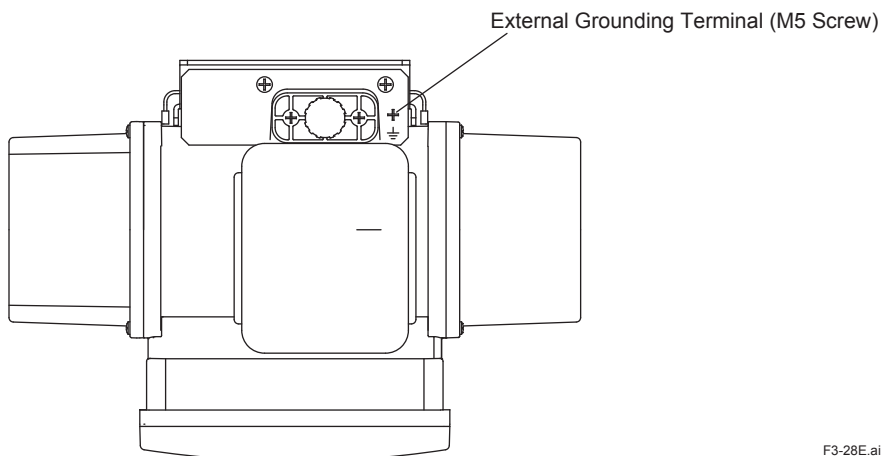

F3-28E.ai

Figure 3.19 Grounding Terminal

3.2.12 Power Wiring for the Ultrasonic Oscillator (When Option Code “/US” is Specified)

This wiring is for supplying a voltage to the TUS400G Ultrasonic Oscillator. When the TUS400G is used in the system, the power supply to the TB750G should be determined in accordance with the supply voltage specified for the TUS400G.



CAUTION

Before opening the front cover of the converter or the detector, turn off power to the TB750G turbidimeter. Make sure that the turbidimeter is not powered before wiring work. Do not touch terminals while the turbidimeter is being powered.

[Cable Required]

Use a 2-conductor cable with a nominal size of at least 0.5 mm² and a finished outside diameter of 6 to 12 mm. The cable performance should also be equivalent to or exceeds that of a 600 V vinyl insulated wire (JIS C3307).

[Procedure]

- (1) Terminating the cable.
Strip off approximately 40 mm of the insulation from both ends of the cable. Terminate the ends of each conductor with crimp terminals corresponding to the M4 screw.
- (2) Connecting the cable to the detector.
Remove the front cover of the TB750G detector and then remove the cover for the power terminals for the ultrasonic oscillator, terminal TUS. Connect the conductors of one end of the cable to terminals L and N. Replace the terminal cover.
To run the cable through the cable gland, remove the assembled parts from the cable gland body at the cable inlet port H and then slide these parts over the cable in order.
- (3) Fixing the cable.
Adjust the cable length housed in the detector and fix the cable by mounting the parts to the cable gland body.
- (4) Connecting the cable to the TUS400G.
Connect the conductors of the other end of the cable to power terminals L1 and L2 on the TUS400G. For details, see the TUS400G User's Manual, IM 19C01B04-01E.

3.2.13 Wiring to the Ultrasonic Transducer (When Option Code “/US” is specified)

This wiring is for connecting a dedicated cable for the ultrasonic transducer, supplied with the TUS400G Ultrasonic Oscillator.

[Procedure]

- (1) Remove the cover of the light source unit located on the left side of the TB750G detector.
- (2) Remove the cover for the terminals for ultrasonic transducer and connect the cable to terminals: conductor U1 to terminal U1 and conductors U2 and U3 to terminal U2. Replace the terminal cover.

To run the cable through the cable gland, remove the assembled parts from the cable gland body at cable inlet port J and then slide these parts over the cable in order.

- (3) Fix the cable. Adjust the cable length housed in the detector and fix the cable by mounting the parts to the cable gland body.
- (4) Connect the other end of the cable to terminals U1, U2, U3 and S on the TUS400G. For details, see the TUS400G User's Manual, IM 19C1B4-01E.

Note: If using an ultrasonic oscillator already installed, take the following procedure: terminate the turbidimeter end of the dedicated cable before wiring.

- (1) Cut off and remove the covering tube at the turbidimeter end of the dedicated cable.
- (2) Strip off approximately 100 mm of the insulation and the shield from the end of the removed covering tube.

Note: When TB750G/US and TUS400G (Application: “-NN” or “-RC”) is specified, noise filter assembly is inserted to power line of TUS400G. For details of wiring, see the TUS400G User's Manual, IM 19C1B4-01E.

3.3 Piping

There are three piping methods in accordance with the system configuration.

- (1) A system using an open head tank
- (2) A system using a pressurized head tank
- (3) A system without a head tank

Depending on the application, select the appropriate system configuration, and install pipes accordingly following the procedure described below.

3.3.1 System Using an Open Head Tank

This is a typical system and the piping diagram is shown in Figure 3.20. Air bubbles in a water sample are removed by an open head tank and the water sample is introduced into the detector at a stable flow rate. Calibration and maintenance such as measurement cell cleaning are efficiently performed by valve operation.

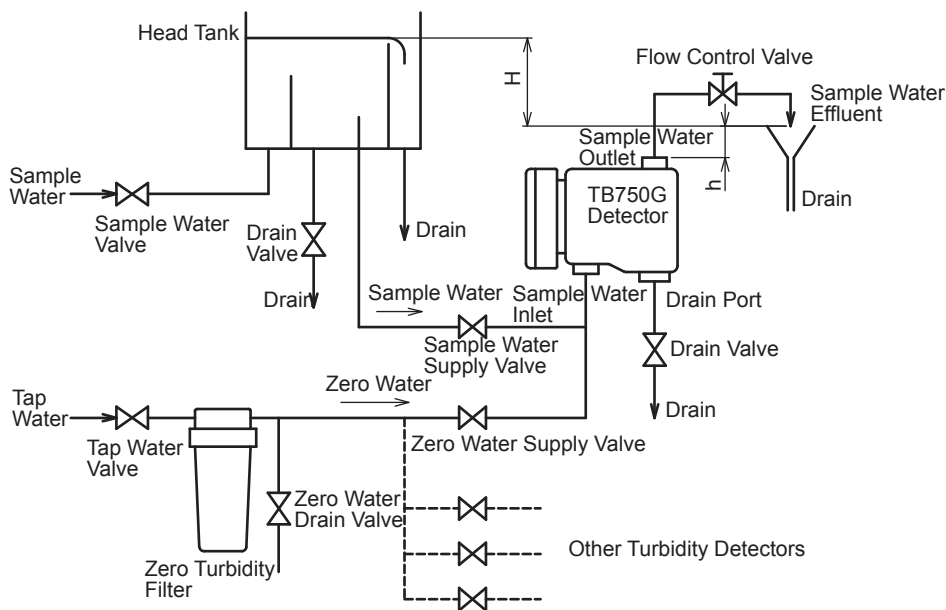

F3-29E.ai

Figure 3.20 Piping Diagram

(1) Piping of the Sample Line to the Detector

This piping is for introducing a water sample into the measurement cell of the detector. Install a head tank, valves and pipes by referring to the diagram in Figure 3.20.

1. For the piping to a head tank, use a hose/tube with sufficient diameter that provides adequate flow of water sample in order to prevent clogging. If pressure exists in a sample water, use an appropriate tube that can withstand the pressure, e.g., a rigid PVC tube.
2. To the sample water inlet of the detector, attach a 3-way (tee) or appropriate fitting corresponding to the inlet's connection size (Rc1/2 or 1/2 NPT). This allows switching of the sample flow and the zero water flow.
3. Connect a sample water supply valve to one end of the 3-way tee fitting, and then connect a hose/tube with sufficient diameter that provides adequate flow of water sample between the valve and the head tank.

4. Although the specified flow rate of the detector is in the range of 0.05 to 20 l/min, the actual flow rate should be at least 2 l/min by adjusting the head difference (H) of the head tank and selecting a hose/tube with appropriate diameter. This is due to the following reasons.
 - To increase the flow rate in the measurement cell of the detector to allow suspended matter to disperse uniformly.
 - To prevent suspended matter to accumulate in the measurement cell.
 - To dislodge air bubbles from the measurement cell and the measurement window surface.Depending on the piping method, a flow rate of 5 to 10 l/min is obtained at a head difference (H) of 1 m with piping with nominal diameter of 16A.
5. To prevent clogging or stagnation of air bubbles in the pipe line, install the pipes so that no bends or stagnation occurs.

(2) Piping of the Sample Line from the Detector

This piping is for draining a water sample from the measurement cell of the detector during measurement.

1. The sample water outlet of the detector is Rc1/2 (or 1/2 NPT female) thread. Install a fitting corresponding to the thread and connect a hose/tube with sufficient diameter that provides adequate flow of water sample, to route the water sample from the detector to a drain pipe.
2. As shown in Figure 3.20, the water sample from the detector should be discharged to the atmosphere at a point (h) higher than the measurement cell of the detector. If not, a siphon may be created and the measurement cell may not be filled with a water sample. In addition, if the sample inflow stops, the water sample will be drawn off and the measurement cell will be emptied, which can cause damage to the ultrasonic transducer, if used.

(3) Drain Piping

This piping is for draining a water sample from the measurement cell of the detector and a head tank during cleaning, calibration, or other maintenance.

1. The drain of the detector is Rc1 (or 1 NPT female) thread. Install a fitting corresponding to the thread and connect a hose/tube with sufficient diameter that provides adequate flow of water sample, to route the water sample from the detector to a drain pipe. Install the pipe so that no bends or stagnation occurs.
2. As shown Figure 3.20, install the pipe so that the water sample can be drained from the head tank to the drain pipe during measurement or maintenance.

(4) Piping of the Zero Water Line

This piping is for introducing tap water to a zero turbidity filter and then to the detector for zero calibration or measurement cell cleaning.

1. As shown in Figure 3.20, install a tap water valve and a zero water drain valve.
2. Connect a zero water supply valve to one end of the 3-way tee fitting attached to the sample water inlet of the detector.
3. Install a fitting corresponding to the piping connection of the zero turbidity filter and connect a hose/tube that can withstand the pressure of tap water, such as a rigid PVC tube. The flow rate of zero water supply should be in the range of 1 to 3 l/min.
4. For the specifications of the zero turbidity filter, see Section 1.2.

- To prevent corrosion of water inside the zero turbidity filter, allow water to flow through the filter and flow out from the zero water drain valve continuously at a flow rate of approximately 10 ml/min.

(5) Optional Simple Head Tank

An optional simple head tank with a vent to the atmosphere (option code "/D2"), shown in Figure 3.21, is available from Yokogawa. The piping diagram of the simple head tank is shown in Figure 3.22. The installation of and the piping for the simple head tank are described below.

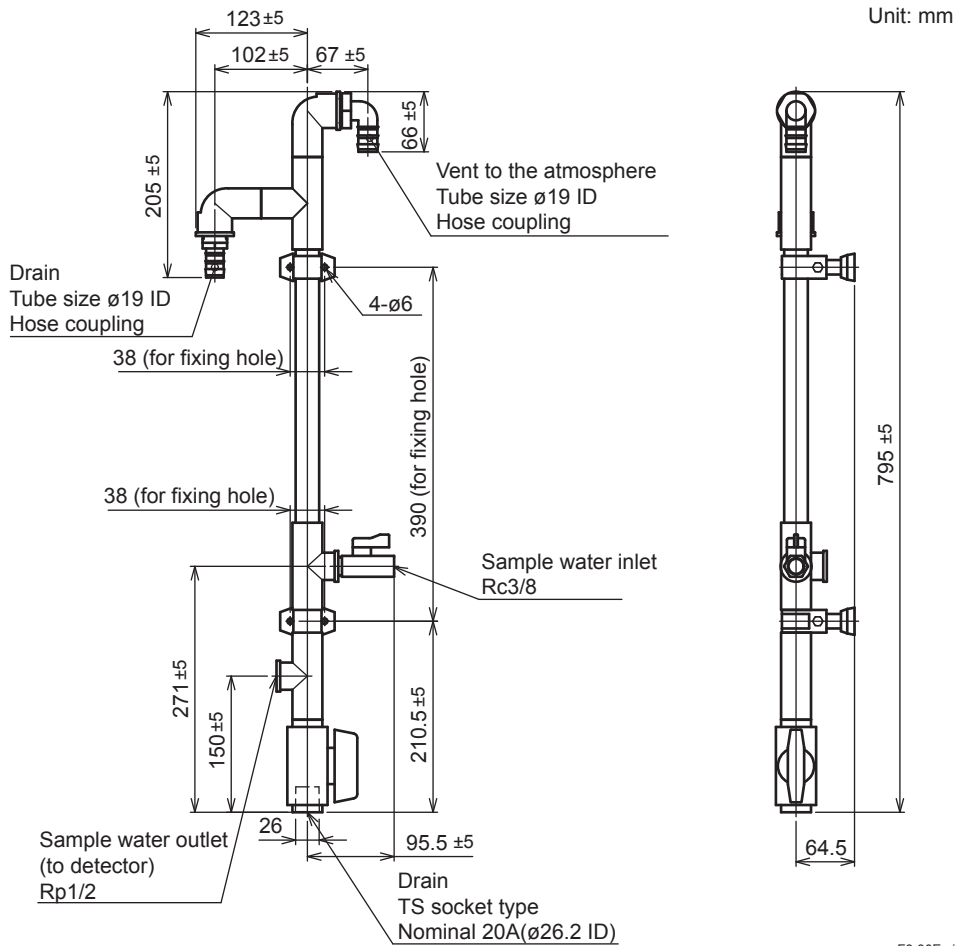
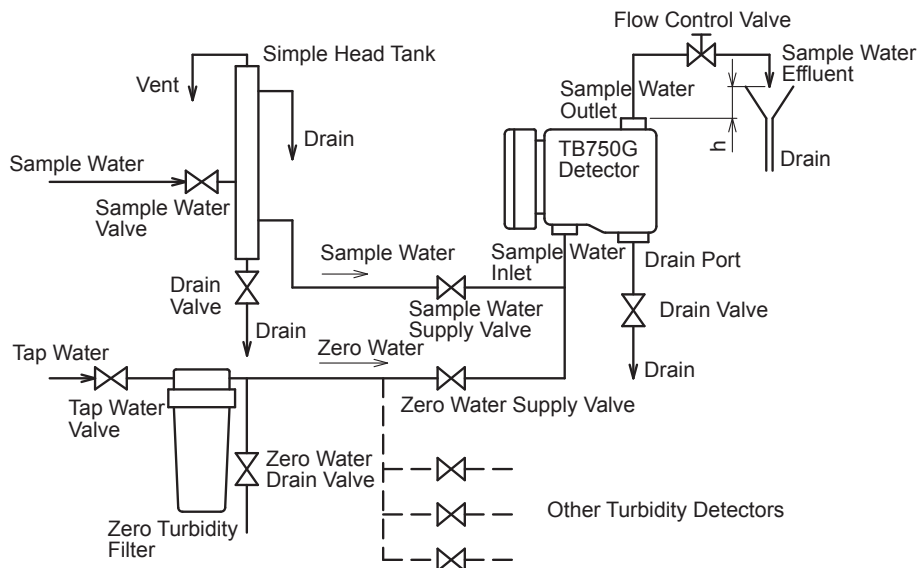

Figure 3.21 Simple Head Tank

F3-30E.ai



F3-31E.ai

Figure 3.22 Piping Diagram

[Installation and Piping of the Simple Head Tank]

1. To the sample water inlet of the detector, attach a 3-way (tee) or appropriate fitting corresponding to the inlet's connection size (Rc1/2 or 1/2 NPT). This allows switching of the sample flow and the zero water flow.
2. Install the simple head tank with the four M5 bolts (supplied by customer) so that the head tank is positioned higher than the detector.
3. To the sample water inlet (Rc3/8) of the simple head tank, connect a fitting corresponding to the connection size and a hose/tube with sufficient diameter that provides adequate flow of water sample. If pressure exists in a sample water, use an appropriate tube that can withstand the pressure, e.g., a rigid PVC tube.
If the flow rate of a water sample exceeds 10 l/min, install a bypass line before the simple head tank to control the flow rate.
4. Connect a fitting corresponding to the connection size and a hose/tube with sufficient diameter that provides adequate flow of water sample between the sample water outlet (Rp1/2) of the simple head tank and the sample water inlet of the detector.
5. Connect hoses with an inside diameter of 19 mm to the drain and the vent at the top of the head tank to drain the sample water to a drain pipe.
6. To the drain at the bottom of the simple head tank, connect a rigid PVC tube corresponding to nominal size 20A (26.2 mm ID) to drain the sample water to a drain pipe.
7. To the sample water outlet of the detector, connect the drain for controlling the flow rate.

3.3.2 System Using a Pressurized Head Tank

In a system using an open head tank, air bubbles may form from air dissolved in a water sample under the reduced pressure in piping and enter into the detector, resulting in an incorrect measurement. For low turbid waters where the effect of air bubbles is a concern, install a pressurized head tank to prevent pressure changes in the piping from the head tank to the detector outlet and thus prevent air bubbles from occurring in the pipe.



CAUTION

Sample water conditions and ambient temperature must meet the specifications: maximum pressure: 500 kPa; sample temperature: 0 to 50°C; ambient temperature: -5 to 50°C. Any failure to meet the specifications may damage the detector or other instruments.

When the sample pressure is reduced by using a pressure reducing valve or by other means, air bubbles may form in the piping. In that case, consider the use of an open head tank.

An optional pressurized head tank for low turbidity measurement (option code "/D1"), shown in Figure 3.23, is available from Yokogawa.

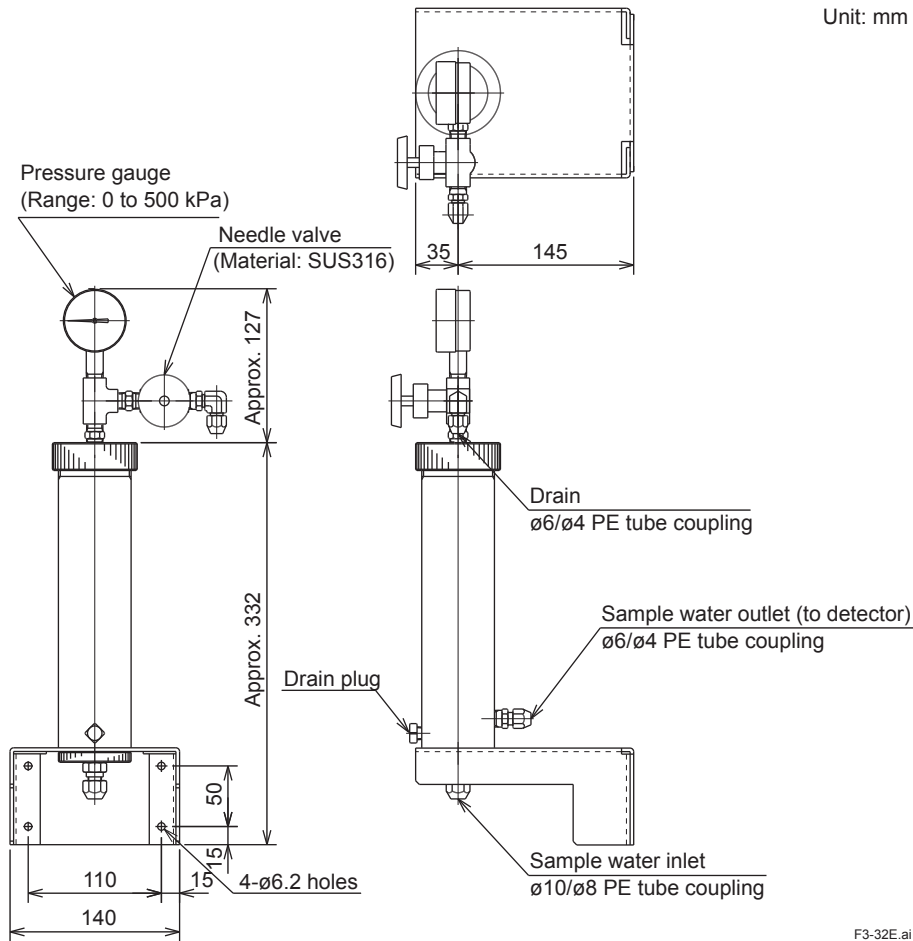
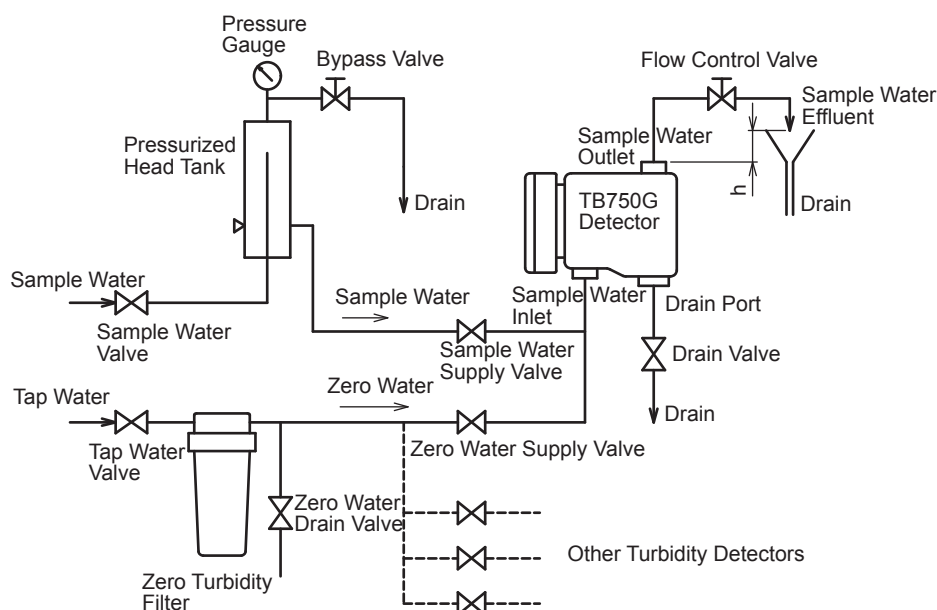

Figure 3.23 Pressurized Head Tank for Low Turbidity

The piping diagram of a system including the pressurized head tank is shown in Figure 3.24.



F3-33E.ai

Figure 3.24 Piping Diagram

(1) Piping of the Sample Line to the Detector

This piping is for introducing a water sample into the measurement cell of the detector. Install a pressurized head tank (for low turbidity), valves and pipes by referring to the diagram in Figure 3.24.

1. For the piping from a sampling point to a sample water valve, use a hose/tube with sufficient diameter that provides adequate flow of water sample in order to prevent clogging. The hose/tube also should withstand the sample pressure. The specified sample pressure when using a pressurized head tank is in the range of 20 to 500 kPa. One example is a rigid PVC tube with nominal size of 16 (22 mm OD).
2. For the piping between the valve and the pressurized head tank, use a 10 mm OD x 8 mm ID polyethylene tube and the corresponding fitting.
3. To the sample water inlet of the detector, attach a 3-way (tee) or appropriate fitting corresponding to the inlet's connection size (Rc1/2 or 1/2 NPT). This allows switching of the sample flow and the zero water flow.
4. For the piping between the pressurized head tank and the detector, connect a valve to one end of the 3-way tee fitting and connect a 6 mm OD x 4 mm ID polyethylene tube and the corresponding fitting between the valve and the pressurized head tank.
5. To the fitting on the bypass valve (needle valve) at the top of the pressurized head tank, connect a 6 mm OD x 4 mm ID polyethylene tube.
6. To prevent clogging or stagnation of air bubbles in the pipe line, install the pipes so that no bends or stagnation occurs.

(2) Piping of the Sample Line from the Detector

This piping is for draining a water sample from the measurement cell of the detector during measurement. As shown in the piping diagram in Figure 3.24, connect a needle valve to the sample water outlet of the detector. By adjusting the opening of this valve and the bypass valve (needle valve) at the top of the pressurized head tank, the pressure change in the piping between the head tank and the detector outlet is controlled, and thus the generation of air bubbles is prevented.

1. To the sample water outlet of the detector, connect a fitting, such as an elbow fitting, corresponding to the connection size (Rc1/2 or 1/2 NPT female) and a needle valve.
2. To the outlet of the needle valve, connect a 6 mm OD x 4 mm ID polyethylene tube using the corresponding fitting to drain the water sample to a drain pipe.
3. As shown in Figure 3.24, the water sample from the detector should be discharged to the atmosphere at a point higher than the measurement cell of the detector. If not, a siphon may be created and the measurement cell may not be filled with a water sample. In addition, if the sample inflow stops, the water sample will be drawn off and the measurement cell will be emptied, which can cause damage to the ultrasonic transducer, if used.

(3) Drain Piping

This piping is for draining a water sample from the measurement cell of the detector and a head tank during cleaning, calibration, or other maintenance.

1. The drain of the detector is Rc1 (or 1 NPT female) thread. Install a fitting corresponding to the thread and connect a hose/tube with sufficient diameter that provides adequate flow of water sample, to route the water sample from the detector to a drain pipe. Install the pipe so that no stagnation occurs.
2. As shown in Figure 3.24, install pipe so that the water sample can be drained from the head tank to the drain pipe.

(4) Piping of the Zero Water Line

This piping is for introducing tap water to a zero turbidity filter and then to the detector for zero calibration or measurement cell cleaning.

1. As shown in Figure 3.24, install a tap water valve and a zero water drain valve.
2. Connect a zero water supply valve to one end of the 3-waytee fitting attached to the sample water inlet of the detector.
3. Install a fitting corresponding to the piping connection of the zero turbidity filter and connect an hose/tube that can withstand the pressure of tap water, such as a rigid PVC tube. The flow rate of zero water supply should be in the range of 1 to 3 l/min.
4. For the specifications of the zero turbidity filter, see Section 1.2.
5. To prevent corrosion of water inside the zero turbidity filter, allow water to flow through the filter and flow out from the zero water drain valve continuously at a flow rate of approximately 10 ml/min.

3.3.3 System without a Head Tank

This is a simple system where a water sample is taken from the process and directly introduced into the detector. This system configuration can be used when a water sample contains a negligible amount of air bubbles or when the turbidity of a water sample is high and the effect of air bubbles is nonsignificant. By installing a throttle at the detector outlet side, it is possible to prevent pressure change and thus air bubbles from occurring in the piping from a sampling point to the detector outlet.



CAUTION

Sample water conditions and ambient temperature must meet the specifications: maximum pressure: 500 kPa; sample temperature: 0 to 50°C; ambient temperature: -5 to 50°C. Any failure to meet the specifications may damage the detector or other instruments.

When the sample pressure is reduced by using a pressure reducing valve or by other means, air bubbles may form in the piping. In that case, consider the use of an open head tank.

The piping diagram of a system without a head tank is shown in Figure 3.25.

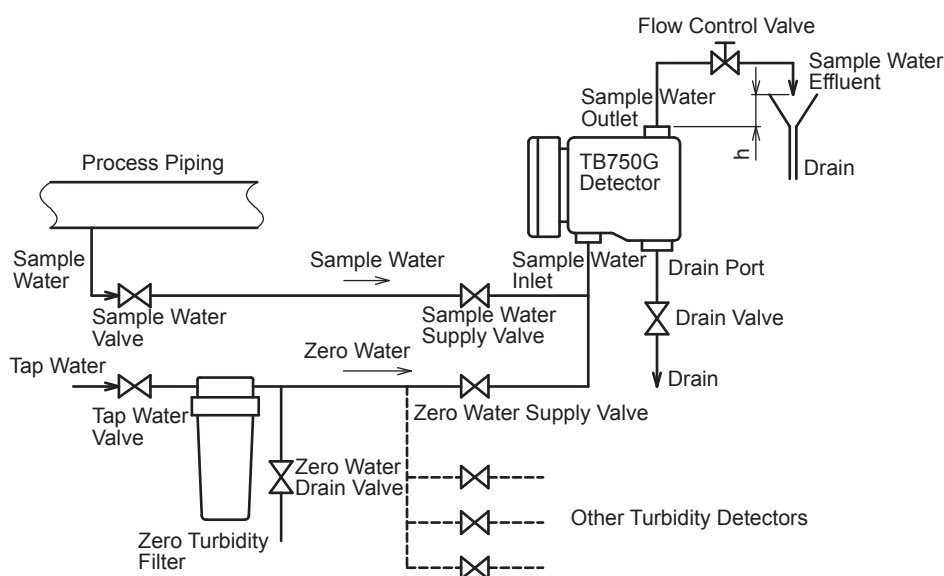

F3-34E.ai

Figure 3.25 Piping Diagram

(1) Piping of the Sample Line to the Detector

This piping is for introducing a water sample into the measurement cell of the detector. Install valves and pipes by referring to the diagram in Figure 3.25.

1. For the piping from a sampling point to the sample water valve in the sample line to the detector, use a hose/tube with sufficient diameter that provides adequate flow of water sample to prevent clogging. The hose/tube also should withstand the sample pressure. One example is a rigid PVC tube with nominal size of 16 (22 mm OD).
2. To the sample water inlet of the detector, connect a 3-way (tee) or appropriate fitting corresponding to the inlet's connection size (Rc1/2 or 1/2 NPT). This allows switching of the sample flow and the zero water flow.

3. For the piping between the sample water and the detector, connect a supply valve to one end of the 3-way tee fitting and connect a hose/tube that can withstand the flow and the pressure of a water sample between two valves using fittings corresponding to the connection sizes of each valve.
4. To prevent clogging or stagnation of air bubbles in the pipe line, install the pipes so that no bends or stagnation occurs.

(2) Piping of the Sample Line from the Detector

This piping is for draining a water sample from the measurement cell of the detector during measurement. As shown in Figure 3.25, connect a needle valve to the sample water outlet of the detector. By adjusting the opening of this needle valve, the pressure change in the piping between the sampling point and the detector outlet is controlled, and thus the generation of air bubbles is prevented.

1. To the sample water outlet of the detector, connect a fitting, such as an elbow fitting, corresponding to the connection size (Rc1/2 or 1/2 NPT female) and a needle valve.
2. To the outlet of the needle valve, connect a fitting corresponding to the valve connection size and a hose/tube that can withstand the flow and the pressure of a water sample. Route this hose/tube to a drain pipe.
3. As shown in Figure 3.25, the water sample from the detector should be discharged to the atmosphere at a point higher than the measurement cell of the detector. If no, a siphon may be created and the measurement cell may not be filled with a water sample. In addition, if the sample inflow stops, the water sample will be drawn off and the measurement cell will be emptied, which can cause damage to the ultrasonic transducer, if used.

(3) Drain Piping

This piping is for draining a water sample from the measurement cell of the detector during cleaning, calibration, or other maintenance.

1. The drain of the detector is Rc1 (or 1 NPT female) thread. Install a fitting corresponding to the thread and connect a hose/tube with sufficient diameter that provides adequate flow of water sample, to route the water sample from the detector to a drain pipe. Take care to install the pipe so that no stagnation occurs.
2. As shown in Figure 3.25, install a pipe so that the water sample drained from the detector to the drain pipe.

(4) Piping of the Zero Water Line

This piping is for introducing tap water passed through a zero turbidity filter, to the detector for zero calibration or measurement cell cleaning.

1. As shown in Figure 3.25, install a tap water valve and a zero water drain valve.
2. Connect a zero water supply valve to one end of the 3-way tee fitting attached to the sample water inlet of the detector.
3. Install a fitting corresponding to the piping connection of the zero turbidity filter and connect an hose/tube that can withstand the pressure of tap water, such as a rigid PVC tube. The flow rate of zero water supply should be in the range of 1 to 3 l/min.
4. For the specifications of the zero turbidity filter, see Section 1.2.
5. To prevent corrosion of water inside the zero turbidity filter, allow water to flow through the filter and flow out from the zero water drain valve continuously at a flow rate of approximately 10 ml/min.

4. OPERATION

4.1 Preparation

4.1.1 Installation, Piping and Wiring Check

Installation Check

Make sure that:

- the TB750G converter and detector are fixed firmly;
- any unused cable inlet ports are plugged with inserts. The front cover of the converter, and the front cover and the right and left side covers of the detector are seated tightly;
- the desiccants are fresh. The detector is of sealed construction and has desiccants inside. Open the left and right side covers, remove the desiccants, and check for softness with the hand. Desiccants soft textured in gel form should be replaced (see Section 7.8).

Wiring Check

Make sure that all the necessary wiring is made correctly. After checking, be sure to attach the terminal cover, the converter front cover and the detector front cover securely.

Piping Check

Make sure that all the necessary pipes, a head tank, a zero turbidity filter and valves are installed by referring to Section 3.3, "Piping."

4.1.2 Supplying Power

First ensure that the power supply to be used for the TB750G turbidimeter meets the specified voltage and frequency. Then, supply power to the TB750G turbidimeter. Upon power up, the software version number appears on the display and the instrument goes into the measurement state.

Main Operation in Measurement Mode (with Factory Parameter Settings)

- The display shows a turbidity reading in NTU. The message display shows the output current of analog output 1.
- A 4-20 mA DC analog output representing turbidity is provided.
- When the turbidimeter detects a failure, the FAIL lamp will turn on and the FAIL contact output will be activated. (NO contact will be closed; NC contact will open.)

4.1.3 Warm-up

Supply zero water to the turbidimeter and allow it to warm up. How to operate the valves is described based on the piping diagrams in Figures 3.20, 3.24, and 3.25.

- (1) Make sure that the valves (the valves on the sample and zero water lines before the detector and the drain valve) are closed.
- (2) The valve after the sample water outlet of the detector, if installed, should be opened completely.
- (3) Open the tap water valve and the zero water drain valve to introduce tap water and check for leakage.
- (4) Loosen the air vent plug on top of the zero turbidity filter and leave it open until tap water overflows from the filter. This is to remove air from the filter. Then close the plug tightly.
- (5) Adjust the opening of the tap water valve until the flow rate of zero water is in the range of 1 to 3 l/min. The flow rate of zero water should be determined by collecting it drained from the zero water drain valve in a beaker or graduated cylinder for a certain amount of time.
- (6) Close the zero water drain valve and open the zero water supply valve to introduce zero water to the detector.
- (7) Upon power up, the turbidimeter needs to warm up for at least one hour. This warm-up is needed also in terms of conditioning of the zero turbidity filter.

4.1.4 Setting and Checking Parameters

Set the relevant parameters to meet the individual operating conditions. Some factory defaults may be used without reconfiguration if appropriate. Even in that case make sure that important parameters are correctly set. If any defaults have been changed, it is good practice to record the changed settings, for example, in the Operation Parameter List at the end of this manual.

The types and operations of parameters are detailed in Chapter 6, which should be read through before parameter setting. For reference the main setting parameters are provided below.

Output Signal

Hold selection mode (operation level)
Output range setting mode (setting level)
Hold parameter setting mode (setting level)
Range switching parameter setting mode (service level: CODE 30)
Analog output 2 range selection mode (service level: CODE 33)
Hold during failure parameter setting mode (service level: CODE 35)
Negative nondisplay/nonoutput selection mode (service level: CODE 54)

Contact Output

Alarm setting mode (operation level)
Alarm setting mode (setting level)
Contact output S1 function selection mode (service level: CODE 40)
Contact output S2 function selection mode (service level: CODE 41)
Delay time/hysteresis setting mode (service level: CODE 44)
Alarm setting function selection mode (service level: CODE 51)

Other Functions

Spike detection parameter setting mode (service level: CODE 08)
Time constant setting mode (service level: CODE 37)
Auto return function selection mode (Service level: CODE 50)

4.1.5 Zero and Span Calibrations (Using Filtered Water as Zero Reference)

When warm-up with zero water flowing is completed and after the turbidity reading stabilizes, calibration should be performed.

Zero Calibration

- (1) Putting the converter into calibration mode (maintenance state).
 1. Press the [MODE] key on the converter.
 2. Check that {CALIB} is shown on the message display. Then, press the [YES] key to enter calibration mode.
- (2) Performing a zero calibration.
 1. Check that the reading stabilizes. Then, close the zero water supply valve at the sample water inlet of the detector.
 2. Check that {STD.CAL} is shown on the message display. Then, press the [YES] key to enter the calibration using standards.
 3. The message display will show {ZERO}. Press the [YES] key to enter the zero calibration.
 4. The message display will show {VALUE}. Check that the data display shows {0.000} and then press the [ENT] key.
 5. The turbidimeter starts the calibration (self-adjustment) with the flashing entire data display. Wait for a while.
 6. After the self-adjustment is completed, the message display will show {CAL.END}.
 7. Press the [NO] key. Check that {STD.CAL} is shown on the message display.

Span Calibration



NOTE

Precautions for Use of the Check Block:

Before using the check block, wash it with mild detergent and then rinse it with water. Do not wipe it dry and use it in wet condition. For cleaning procedures, refer to "How to Clean the Check Block" on Subsection 7.6.2..

Following the zero calibration, perform a span calibration using the check block.

- (1) Installing the check block.
 1. Make sure that the zero water supply valve at the sample water inlet of the detector is closed. Then, open the drain valve to drain zero water.
 2. Remove the rubber cover from the top of the detector.
 3. Remove the retaining plate on the window of the top cover by loosening the 2 setscrews.
 4. Detach the observation window and replace it with the check block. Fix it with the 2 setscrews securely.
- (2) Introducing zero water.
 1. Open the zero water supply valve at the sample water inlet of the detector to introduce zero water.
 2. Check that zero water is drained from the drain of the detector. Then, close the drain valve.
 3. Supply zero water for approximately 5 minutes.

- (3) Performing a span calibration.
 1. Check that the reading stabilizes. Then, close the zero water supply valve. Check that {STD. CAL} is shown on the message display. Then, press the [YES] key to enter the calibration using standards.
 2. The message display will show {ZERO}. Press the [NO] key. The display will show {SPAN} and then press the [YES] key to enter the span calibration.
 3. The message display will show {VALUE}. The data display should read the same value as the one described on the check block, and press the [ENT] key.
 4. The turbidimeter starts a calibration (self-adjustment) with the flashing entire data display. Wait for a while.

Note: Pressing the [ENT] key during the self-adjustment will abort the calibration. Do not press any keys unless you want to abort the calibration.
 5. After the self-adjustment is complete, the message display will show {CAL. END}.
- (4) Removing the check block.
 1. Open the drain valve of the detector to drain zero water.
 2. Remove the check block by loosening the 2 setscrews.
 3. Replace the observation window and fix the retaining plate with the 2 setscrews securely.
 4. Replace the rubber cover to the top of the detector.
- (5) Exiting from the calibration mode and putting the converter into the measurement mode.
 1. Check that {CAL.END} is shown on the message display. Press the [YES] key.
 2. Check that {HOLD} is shown on the message display. Press the [NO] key to cancel the maintenance state (output hold state) and put the converter into measurement mode.

4.1.6 Zero and Span Calibrations (2-point Calibration Using Standard Solutions)

This section describes how to perform a 2-point calibration using standard solutions. Prepare two types of turbidity standard solutions: one with approximately zero turbidity and the other with approximately span turbidity. For the turbidity standards used for calibration, see Section 1.3, "Formazin Standard Solution."

- (1) Putting the converter in calibration mode (maintenance state).
 1. Press the [MODE] key on the converter. The message display should show {CALIB}.
 2. Press the [YES] key to enter calibration mode.
- (2) Washing the measurement cell.
 1. Open the zero water supply valve to supply zero water to the detector.
 2. Close the drain valve after the detector. When the measurement cell is filled with the water, open the drain valve to drain.
 3. Repeat steps 1 and 2 at least three times to wash the inside of the measurement cell.
- (3) Rinsing the measurement cell with the zero calibration solution.
 1. Make sure that the zero water supply valve and the drain valve are closed.
 2. Remove the rubber cover from the top of the detector. Remove the top cover by loosening the 6 setscrews.
 3. Slowly pour the zero calibration solution into the measurement cell, taking care not to allow air bubbles to enter the cell. When the measurement cell is filled to approximately 90% with the solution, open the drain valve to drain the calibration solution.
 4. Continue to pour the zero calibration solution to rinse the measurement cell.

- (4) Supplying the zero calibration solution to the measurement cell.
1. Close the drain valve after the detector. Slowly pour the zero calibration solution into the measurement cell, using a funnel or relevant equipment, taking care not to allow air bubbles to enter the cell. Care should be taken that the end of the funnel does not contact with the solution level.

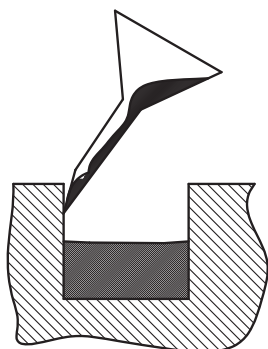

F4-1E.ai

Figure 4.1 How to Pour the Standard Solution

2. The measurement cell should be filled to 90% with the zero calibration solution. Replace the top cover, fix it securely with the 6 setscrews, and attach the rubber cover.
- (5) Performing a zero calibration.
1. Wait 3 to 5 minutes until the reading has stabilized. Check that {STD.CAL} is shown on the message display.
 2. Press the [NO] key. The message display should show {SMP.CAL}. Press the [YES] key.
 3. The message display should show {ZRSPN}. Press the [YES] key to select the zero calibration.
 4. The message display should show {VALUE.Z}.
 5. Set the decimal point position in the data display using the [>] key. Press the [ENT] key to accept the position.
e.g., "0.000"
 6. Set the value on the data display to the value of the zero calibration solution using the [>] and [^] keys and press the [ENT] key.
e.g., "0.020"
 7. The turbidimeter starts a calibration (self-adjustment) with the flashing entire data display. Wait for a while.
Note: Pressing the [ENT] key during the self-adjustment will abort the calibration. Do not press any keys unless you want to abort the calibration.
 8. After the self-adjustment is complete, the message display will show {SPAN}.
Note: At this stage, the zero calibration has not been yet reflected in measured values. A calibration factor will be calculated after the span calibration is completed.
- (6) Open the drain valve after the detector to drain the zero calibration solution.
- (7) Rinsing the measurement cell with the span calibration solution.
1. Make sure that the zero water supply valve and the drain valve are closed.
 2. Remove the rubber cover from the top of the detector. Remove the top cover by loosening the 6 setscrews.
 3. Slowly pour the span calibration solution into the measurement cell, taking care not to allow air bubbles to enter the cell. When the measurement cell is filled to approximately 90% with the solution, open the drain valve to drain the calibration solution.
 4. Continue to pour the span calibration solution to rinse the measurement cell.

- (8) Supplying the span calibration solution to the measurement cell.
 1. Close the drain valve after the detector. Slowly pour the span calibration solution into the measurement cell, using a funnel or relevant equipment, taking care not to allow air bubbles to enter the cell. Care should be taken that the end of the funnel does not contact with the solution level.
 2. The measurement cell should be filled to 90% with the span calibration solution. Replace the top cover, fix it securely with the 6 setscrews, and attach the rubber cover.
- (9) Performing a span calibration.
 1. Wait 3 to 5 minutes until the reading has stabilized. Check that {SPAN} is shown on the message display. Press the [YES] key to select the span calibration.
Note: Pressing the [NO] key is invalid.
 2. The message display should show {VALUE.S}.
 3. Set the decimal point position in the data display using the [>] key. Press the [ENT] key to accept the position.
e.g., "00.00"
 4. Set the value on the data display to the value of the span calibration solution using the [>] and [^] keys and press the [ENT] key.
e.g., "20.00"
 5. The turbidimeter starts a calibration (self-adjustment) with the flashing entire data display. Wait for a while.
Note: Pressing the [ENT] key during the self-adjustment will abort the calibration. Do not press any keys unless you want to abort the calibration.
 6. After the self-adjustment is complete, the message display will show {CAL.END}.
- (10) Open the drain valve after the detector to drain the span calibration solution.
- (11) Open the sample water supply valve to supply the water sample to the detector. It will take time for the complete replacement of the calibration solution in the measurement cell with the water sample.
- (12) Putting the converter in measurement mode.
 1. When {CAL.END} is shown on the message display, press the [YES] key.
 2. The message display should show {HOLD}. Press the [NO] key to exit from the maintenance state (output is held) and return to measurement mode.
Note: If the analog output hold function has been set to Disabled {*H.OFF} in SET HOLD mode at the setting level, a {HOLD} display in step 2 is not shown.
- (13) Calibration is now complete.
Note: After a 2-point calibration, a zero point correction or a sensitivity correction, the turbidity meter will not show the value indicated on the check block even if the check block is installed in zero solution in measurement mode. The value on the check block is valid only for STD.CAL.

4.1.7 Supplying a Water Sample and Adjusting the Flow Rate

Supply a sample water to the detector and adjust its flow rate.

System Using an Open Head Tank (See Piping Diagram in Figure 3.20)

- (1) Open the sample water valve to supply a water sample to the head tank.
- (2) Completely open the sample water supply valve to allow the water sample to flow into the detector.
- (3) Check that the water sample is drained from the detector drain. Then, close the drain valve.
- (4) Adjust the opening of the valve at the sample water out of the detector so that the water sample overflows and is surely drained from the head tank.

- (5) Measure the drainage volume at the sample water outlet of the detector using a beaker or relevant measure. The rate of flow to the detector must be in the range of 0.05 to 20 l/min.

System Using a Simple Head Tank (See Piping Diagram in Figure 3.22)

- (1) With the drain valve after the detector open completely, open the valve at the inlet of the simple head tank gradually and completely.
- (2) By gradually close the valve at the sample water out of the detector, adjust the flow rate so the water sample is thoroughly drained from the drain of the simple head tank.
- (3) Close the sample water supply valve while checking the turbidity reading until the influence of air bubbles disappears. Check that the water sample is overflowing from the drain of the simple head tank.

System Using a Pressurized Head Tank (See Piping Diagram in Figure 3.24)

- (1) Completely open the bypass valve at the top of the head tank, the sample water supply valve, and the needle valve at the sample water outlet of the detector.
- (2) Open the sample water valve to supply a water sample to the head tank.
- (3) Gradually close the bypass valve at the top of the head tank until the rate of flow from the sample water outlet of the detector is in the range of 0.05 to 10 l/min. The rate of drainage from the bypass valve should be secured to the extent that air bubbles are removed.
- (4) Pressure changes in the line between the sampling point and the detector outlet should be controlled to prevent air bubbles from occurring. For this, gradually close the valve at the sample water outlet of the detector until the pressure gauge at the tops of the pressurized head tank approximates the pressure of the water sample and until the rate of flow from the sample water outlet of the detector is in the range of 0.05 to 10 l/min. Check the pressure gauge at the top of the pressurized head tank. The gauge must read under 500 kPa.

System without a Head Tank (See Flow Diagram in Figure 3.25)

- (1) With the valve at the sample water outlet of the detector opened completely, open the sample water valve (immediately after the sampling point) in the sample line.
- (2) Open the sample water supply valve to supply a water sample to the detector.
- (3) Adjust the opening of the valve at the sample water out of the detector until the rate of flow from the sample water outlet of the detector is in the range of 0.05 to 20 l/min.
- (4) Pressure changes in the line between the sampling point and the detector outlet should be controlled to prevent air bubbles from occurring. For this, gradually close the needle valve at the sample water outlet of the detector until the rate of flow from the sample water outlet of the detector is in the range of 0.05 to 20 l/min. Before taking this procedure, make sure that the sample water pressure of the process is under 500 kPa.

4.1.8 Operation Check

After supplying the water sample and adjusting its flow rate, activate all the instruments in the loop configuration, such as ultrasonic cleaning equipment. Continue a test run for a while and make sure that the system is free of defects. Then, put the system into normal operation.

4.2 Normal Operation

The TB750G turbidimeter does not normally require any manual operations except when periodic cleaning/calibration is performed or when a failure occurs.

4.2.1 When a Failure Occurs

If the TB750G turbidimeter detects a failure, it provides a FAIL contact output. The message display shows the error number that tells what kind of failure has occurred. Check the number and take remedial actions accordingly and immediately. For details on error descriptions, refer to Chapter 8.

4.2.2 Inspection and Maintenance

The turbidimeter should be washed and calibrated at appropriate intervals so that the deviations of readings are within tolerance. For inspection/maintenance items and intervals, see Section 7.1.

4.2.3 When Sample Water Supply is Cut Off

The turbidity measurement is not affected by temporary suspension of sample water supply, but long-term suspension may interfere with the accuracy of the instrument. Since the TB750G cannot detect whether the sample water supply is stopped or not, periodical check of the sample line is needed.

4.2.4 When a Power Failure Occurs

The parameter settings and other information set in the turbidimeter will not disappear when power fails. After power is returned, the turbidimeter will recover to the measurement state. Note that the depending on how long the power outage has lasted, it takes approximately one hour for the detector to stabilize after power has been returned. The output signals during that period may not represent turbidity values correctly. Give attention to this if the turbidimeter is used for control.

4.3 Operation Shutdown and Restart

4.3.1 Shutdown

The parameter settings and other information set in the turbidimeter are retained even if power is turned off. If the instrument will be out of operation for a long period, power should be removed. Dirt or stains on the instrument should be washed off thoroughly when the turbidimeter is to be removed from the site. Rinse the inside of the measurement cell, and then empty the cell or keep zero water running through the cell.

4.3.2 Restart

When power is returned, the turbidimeter is put into the measurement state. It requires at least one hour for warm-up upon power up. After warm-up, check that the reading stabilizes well, and then perform calibration.

5. CONVERTER OPERATION

This chapter describes how to operate the converter to set various parameters.

5.1 Outline

5.1.1 Operation, Setting, and Service Levels

Parameters should be set in the relevant mode that is classified into three levels: operation, setting and service.

Upon power up, the turbidimeter enters the normal measurement state (measurement mode) and the pointer on the display indicates <MEASURE>.

The transition between measurement mode and three levels is outlined in Figure 5.1.

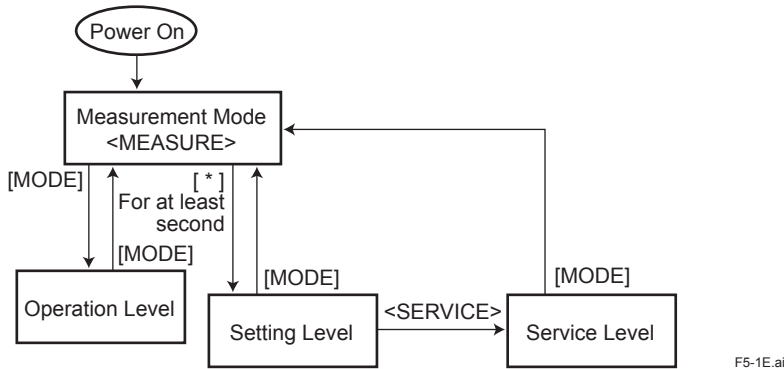

Figure 5.1 Transition between Measurement Mode and Three Levels

Operation Level

This is the level where, basically, operations regarding routine inspections and maintenance, such as calibration and manual cleaning, can be done. Also, the desired display item on the message display can be selected at this operation level.

Setting Level

There are modes where parameters regarding output signals and contact outputs can be set.

Service Level

The TB750G turbidimeter has various functions. At this level there are modes where functions can be selected according to need for the operation.

5.1.2 Key Operations

The TB750G offers interactive key operations through indications on the data and message displays, pointer positions (mode selection), and key indicators on the converter's front display.

For basic key operations, see Section 5.2.

Interactive Display

- **Flashing Pointer**

This is asking you whether to enter the mode the flashing pointer is indicating. Once you enter the mode, the pointer stops flashing and is lit continuously. When the turbidimeter is in a mode at the setting/service level, an asterisk (*) is indicated to the left of the item in the message display.

- **Flashing Key Indicator**

This is prompting you to select the desired operation from among the flashing key indicators on the display. Press the corresponding key.

- **Flashing Data Display (Numeric Character)**

This is asking you whether to change the value of the flashing digit. Change the value, if necessary, and move to another digit, using relevant keys. To exit from the flashing data display, press the [ENT] key.

How to Abort the Setting Procedure

Press the [MODE] key.

Normally, the [MODE] key is used to enter the operation level from measurement mode; however, it is also used to return to measurement mode from any mode other than measurement mode.

If the output signal hold function is activated when the [MODE] key is pressed in any mode other than measurement mode, the converter goes into "hold selection" mode.

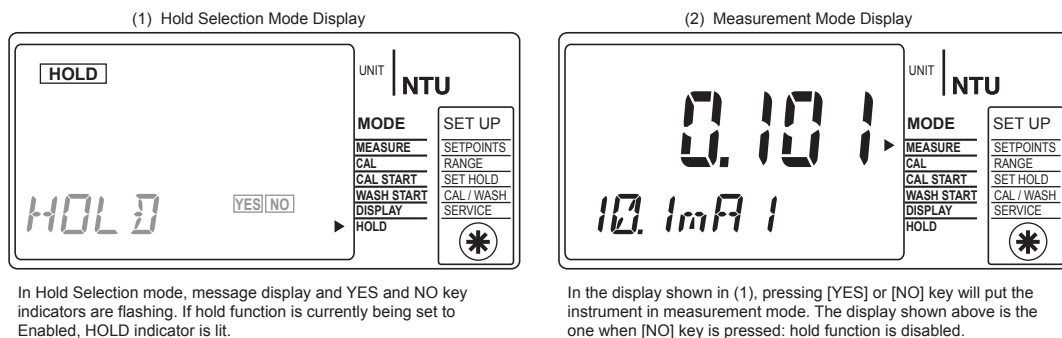

Figure 5.2 Display When [MODE] Key is Pressed in Mode Other Than Measurement Mode

Auto Return to Measurement Mode

If no key is operated for 10 minutes in any level, the converter will automatically return to measurement mode, except when the instrument is in calibration mode. This auto return function does not work when it is set to "0: Disabled" in CODE 50 (auto return function selection mode) at the service level.

5.1.3 Password

If a password is set in CODE 52 (password setting mode) at the service level, each level cannot be accessed without entering the relevant password.

A password prompt appears when you attempt to access:

- the operation level by pressing the [MODE] key in measurement mode;
- the setting level by pressing the [*] key in measurement mode; or
- the service level by pressing the [YES] key when {*SERV} appears on the message display.



F5-3E.ai

Figure 5.3 Example of Password Prompt Display

5.2 Key Operation Procedures

This section describes basic procedures for operating keys to demonstrate how to use the keys and how to check the instrument operation. For key operations for checking or changing parameter settings, see Chapter 6.

5.2.1 Operation Panel

Figure 5.4 shows the operation panel of the TB750G converter. The panel consists of an LCD screen, operation keys and lamps.

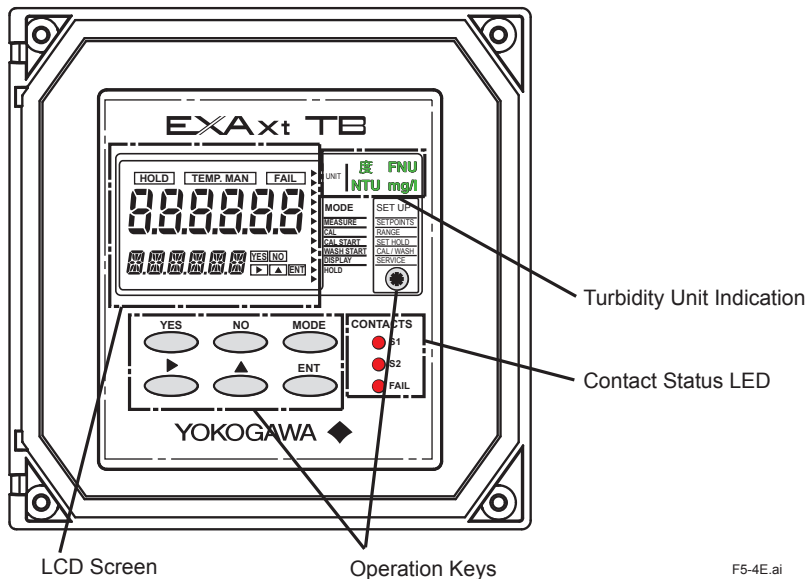

F5-4E.ai

Figure 5.4 Operation Panel

(1) LCD Screen

Figure 5.5 shows the LCD screen that consists of a data display, a message display, status indicators, key indicators, and a pointer.

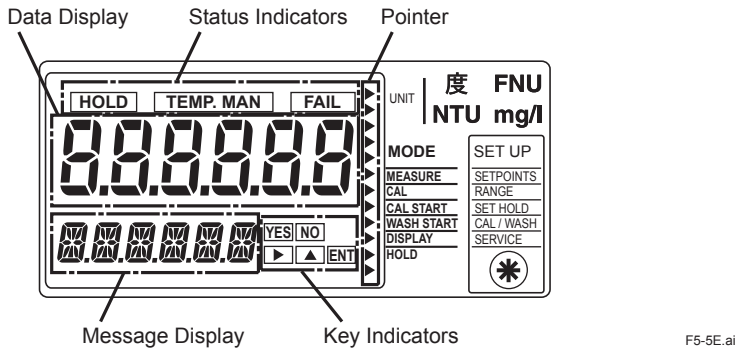

Figure 5.5 LCD Screen

Data display: Shows turbidity data.

Message display: Shows output current, message, etc.

Status indicators:

HOLD: Lit while analog output is being held.

TEMP.MAN: Not lit in operation. Instantaneously lit only when converter goes through an internal check upon power up.

FAIL: Lit continuously or flashes when a failure is detected.

Key indicators: Flashes when prompting (Note that >, ^, and ENT indicators flashes in the block even if only the ENT indicator prompts.)

Pointer: Lit when indicating the current (level) mode.

Flashes when asking you whether to enter the mode. Lit when the [YES] key is pressed to accept.

(2) Operation Keys

[YES]: To answer “yes.”

[NO]: To answer “no.”

[>]: To move the flashing digit to the next in parameter setting; To move the decimal point.

[^]: To increase the value of the flashing digit by one increment in parameter setting.

[ENT]: To accept the keyed-in values or item.

[MODE]: To enter the operation level from measurement mode. When in any mode other than measurement mode, this is to cancel the current procedure and return to measurement mode.

[*]: To enter the setting level from measurement mode. Only this key should be pressed and held for at least one second to prevent accidental key presses.

(3) Lamps

Contact status LED: Lit when S1/S2/FAIL contact is activated.

Turbidity unit indication: Turbidity unit indication is lit.

5.2.2 Panel Display upon Power Up

The TB750G converter operates at the rated voltage. Before operating, the installation, piping and wiring should be made in accordance with the instructions in Chapter 3.



CAUTION

Before opening the front cover of the converter or the detector, turn off power to the TB750G turbidimeter. Make sure that the turbidimeter is not powered before wiring work. Do not touch terminals while the turbidimeter is being powered.



NOTE

The TB750G turbidimeter does not have an internal power switch. Be sure to provide a switch (double pole type, compliant with IEC 60947-1 and IEC 60947-3) in the power line as close to the instrument as possible. The “I” (on) and “O” (off) symbols should be indicated near the switch if they are not indicated on the switch.

Upon power up, the converter will go into measurement mode; if the turbidimeter is set to factory defaults, the data display will show turbidity values in NTU and the message display will show output current values.

If the converter detects a failure, the FAIL indicator will turn on and an error code will appear on the message display. The FAIL contact status lamp will turn on only when a level-1 error occurs. If a failure occurs, refer to Chapter 8.

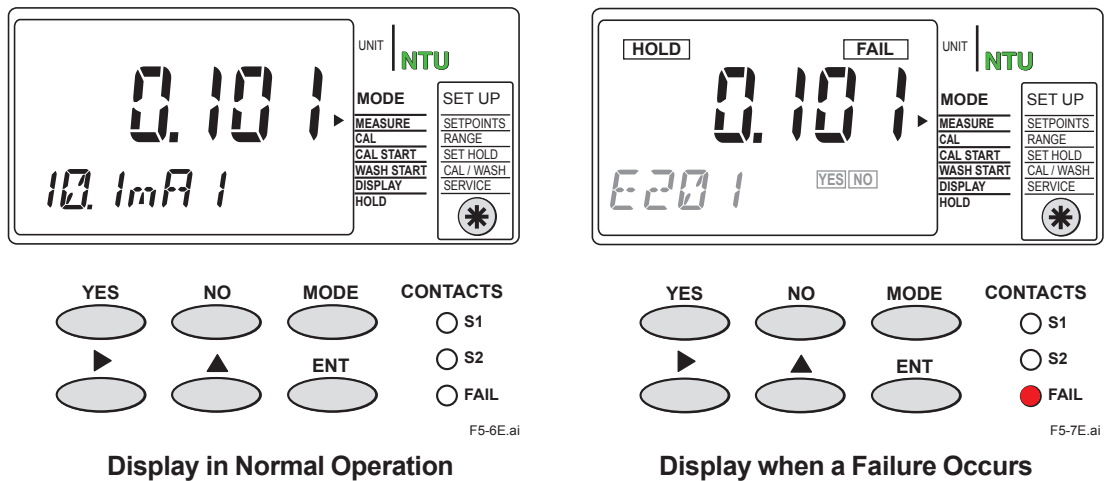

Figure 5.6 Examples of Measurement Mode Displays

5.2.3 Basic Key Operations

Key operation can be done by touching keys over the front cover. With the front cover attached, operate keys to check that the instrument responds accordingly.

Note the following two points for mode switching.

- Pressing the [MODE] key when in any mode other than measurement mode, will return the instrument to measurement mode.
- If the turbidimeter is set to factory defaults, it will return to measurement mode via the HOLD display.

(1) Mode Switching at the Operation Level (see Chapter 6 for details)

1. Press the [MODE] key once. The display shown in Figure 5.7 (1) appears.

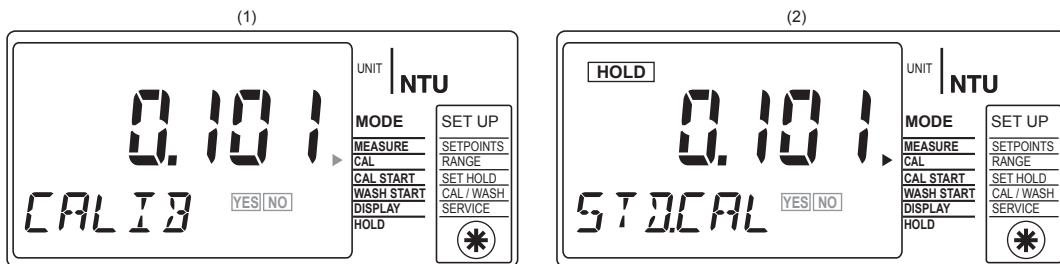

Pointer is flashing at <CAL> mode and YES and NO key indicators are flashing. This is asking you whether to enter calibration mode and prompting you to answer by pressing [YES] or [NO] key.

Display shown above appears when [YES] key is pressed. Pointer stops flashing and {STD.CAL} appears on message display with next prompts. HOLD indicator depends on setting.

F5-8E.ai

Figure 5.7 Examples of Displays at the Operation Level

2. When the display shown in Figure 5.7 (1) appears, press the [NO] key. Another mode will appear. Each time the [NO] key pressed, the display switches and shows another mode prompt screen. After the display cycles through the mode menus, it returns to the one shown in Figure 5.7 (1).

(2) Switching to the Setting Level (see Chapter 6 for details)

To switch to the setting level, press and hold the [*] key for at least one second when in measurement mode.

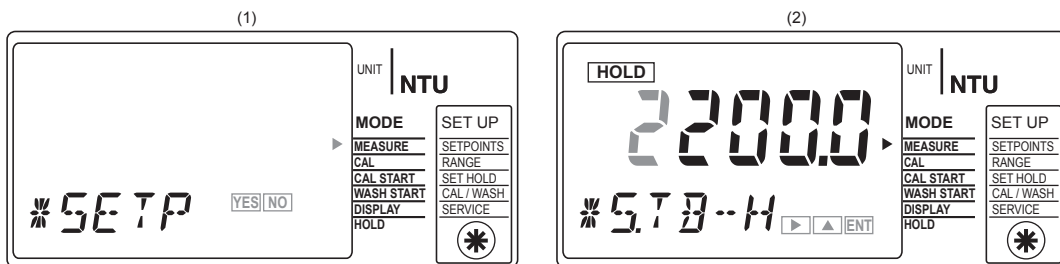

Pointer is flashing at <SETPOINTS> mode and YES and NO key indicators are flashing. This is asking you whether to enter alarm setting mode and prompting you to answer by pressing [YES] or [NO] key.

Display shown above appears when [YES] key is pressed. Pointer stops flashing, {*S.TB-H} appears on message display, and the leftmost digit of data display flashes, prompting data entry. HOLD indicator depends on setting.

F5-9E.ai

Figure 5.8 Examples of Displays at the Setting Level

Once the turbidimeter enters the setting or service level, a message with an asterisk (*) will appear.

(3) Entry of Numeric Values



NOTE

Keyed-in and accepted values will not disappear even if power is turned off. Tentatively keyed-in values should be reset.

As an example to demonstrate how to enter a numeric value, take the display shown in Figure 5.8 (2). A procedure for changing {2200.0} to {0050.0} is described below.

1. Press the [^] key repeatedly until flashing “2” changes into “0.”
2. Press the [>] key to move the flashing digit to next “2” and change it into “0” using the [^] key.
3. Press the [>] key to move the flashing digit to next “0” and change it into “5” using the [^] key.
4. Press the [ENT] key. The value of {0050.0} will be accepted and the display will move to the next setup prompt screen ({*S.TB-L}).

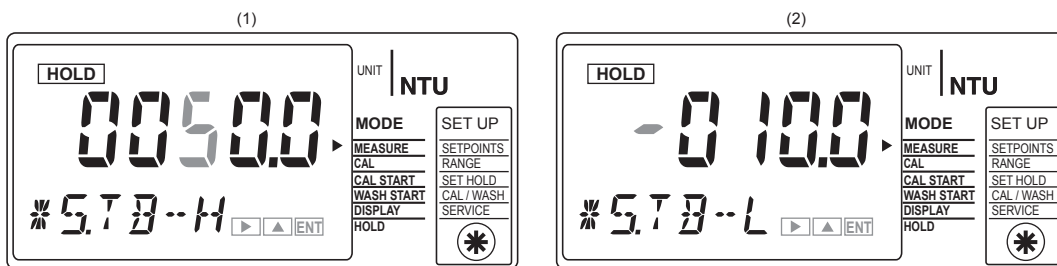

Display in step 3. HOLD indicator depends on setting.

Display when [ENT] is pressed in step 4. {*S.TB-L} appears on message display and the leftmost digit of data display flashes, prompting data entry. HOLD indicator depends on setting.

F5-10E.ai

Figure 5.9 Examples of Data Entry Displays

(4) Moving a Decimal Point

A decimal point can be moved in the significant digit of 4 (X.XXX to XXXX) or of 6 (X.XXXXXX to XXXXXX) using the [>] key. This is available only in:

- CALIB mode at the operation level: setting a turbidity value;
- CODE 11 at the service level: setting a zero calibration factor;
- CODE 17 at the service level: setting a turbidity value of the check block; and,
- CODE 18 at the service level: setting a turbidity value in the reference sensitivity calibration.

Procedure (In Case of the Significant Digit of 6)

1. Determining the decimal point.
The first display should show “0.00000” with the decimal point flashing. Move the flashing decimal point using the: Upon each press of the [>] key, the indication will change “0.00000” → “00.0000 → 000.000 → 0000.00 → 00000.0 → 000000 (no decimal point) and return to “0.00000.” When the desired indication is shown, press the [ENT] key to accept.
2. Setting the value.
Note that if the [>] key is pressed when the rightmost digit is flashing, the current decimal point will be flashing. Then, each press of the [>] key will cycle through the decimal point as described above, and then the leftmost digit will be flashing.

(5) Password Entry

To prevent unauthorized access, the operation, setting, and/or service levels can be individually protected by a password (nine password options selectable). If a password has been set for the level, a password prompt will appear when you attempt to access that level (see Section 5.1.3). When the instrument is shipped from the factory, no passwords are preset, thus a password prompt will not appear.

5.3 Setting Parameter List

Lists of setting parameters at each level are provided in this section.

5.3.1 Setting Parameters at the Operation Level**Table 5.1 Setting Parameters at the Operation Level**

Mode	Setting Parameter	Display	Setting Range	Default
CAL	Calibration	CALIB		(See page 6-2)
	Using turbidity standards, or using water sample	STD.CAL or SMP.CAL		
	Start	ZERO or SPAN or ZRSPN		
	Turbidity value	VALUE	0.001 to 2000[NTU] *1	
	Self-adjustment in process	ZERO or SPAN		
	End	CAL.END		
CAL START			Not available	
WASH START			Not available	
DISPLAY	Message display selection	DISP		(See page 6-4)
	Analog output 1 current	XX.XmA1		Output 1 current
	Analog output 2 current	XX.XmA2		
	Switchable output range state	RNG1/2-A/B/C		*2
(No pointer at mode display)	Alarm setting	* SETP		*3 (See page 6-4)
	High alarm setpoint	* S.TB-H	-010.0 to 2200.0[NTU] *1	2200.0 (NTU)
	Low alarm setpoint	* S.TB-L	-010.0 to 2200.0[NTU] *1	-010.0 (NTU)
HOLD	Hold selection	HOLD		*4 (See page 6-5)
	Hold selection			(Disabled)

*1: Although setting range is up to 2000 NTU, measuring range is up to 100 NTU.

*2: Skipped if analog output range switching selection {*RNGPR} is set to "0: Fixed" in CODE 30 at service level.

*3: Skipped if alarm setting function is set to "0: Disabled" in Code 51 at service level, or if either of function of contact output S1 or S2 is not set to "1: Alarm" in Code 40 or 41 at service level.

*4: Skipped if hold function is set to "*H.OFF: Disabled" in SET HOLD mode at setting level.

5.3.2 Setting Parameters at the Setting Level

Table 5.2 Setting Parameters at the Setting Level

Mode	Setting Parameter	Display	Setting Range	Default
SETPOINTS	Alarm setting	* SETP		(See page 6-7)
	High alarm setpoint	* S.TB-H	-010.0 to 2200.0[NTU]	2200.0 (NTU)
	Low alarm setpoint	* S.TB-L	-010.0 to 2200.0[NTU]	-010.0 (NTU)
RANGE	Analog output range setting	* RANGE		(See page 6-7)
	Fixed range for output 1, or fixed range for output 2	* FIXR.1 or * FIXR.2		
	Zero point	* ZERO	0000.00 to 2000.00[NTU]	0000.00 (NTU)
	Span point	* SPAN	0000.00 to 2000.00[NTU]	0100.00 (NTU)
	Local range selection	* LOCAL		
	Local range for output 1, or local range for output 2	*LCL.1 or *LCL.2	0, 1, 2	0 :Range A
SET HOLD	Hold parameter setting	* HOLD		(See page 6-9)
	Hold function enabled, or hold function disabled	* H.ON or * H.OFF	* H.ON (Enabled) * H.OFF (Disabled)	* H.ON :Enabled
	Last measured value, or fixed value	* H.LST or * H.FIX	* H.LST (Last measured value) * H.FIX (Fixed value)	* H.LST :Last measured value
	Fixed value for output 1	* H.mA1	02.0 to 22.0[mA]	22.0 (mA)
	Fixed value for output 2	* H.mA2	00.0 to 22.0[mA](0-20mA) 02.0 to 22.0[mA](4-20mA)	22.0 (mA)
CAL/WASH			Not available	
SERVICE				*2

*1: Skipped if alarm setting function is set to "0: Disabled" in Code 51 at service level, or if either of function of contact output S1 or S2 is not set to "1: alarm" in Code 40 or 41 at service level.

*2: For service level, see Section 6.3.

5.3.3 Setting Parameters at the Service Level

At the service level, enter the code number of the desired setting mode to access.

Table 5.3 Setting Parameters at the Service Level (1/3)

Code	Setting Parameter	Display	Setting Range	Default
CODE02	Input voltage display			(See page 6-11)
	Transmitted light detection element input display	<i>*IN1</i>		
	Scattered light detection element input display	<i>*IN2</i>		
	End	<i>*END</i>		
CODE08	Spike detection parameter setting			(See page 6-12)
	Spike detection function enabled or disabled	<i>*SPIKE</i>	0, 1	0 :Disabled
	Limit value	<i>*LIMIT</i>	000.000 to 999.999	999.999 (NTU)
	Hold time	<i>*HLD-T</i>	005 to 600[s]	030 (s)
	Sampling time	<i>*SMP-T</i>	001 to 600[s]	030 (s)
CODE11	Zero calibration factor display			(See page 6-15)
	Zero calibration factor display	<i>*CAL.A</i>		Depends on MS Code
CODE12	Slope display			(See page 6-15)
	Slope display	<i>*SL</i>		100.0 (%)
CODE13	Zero correction factor setting			(See page 6-15)
	Zero correction factor setting	<i>*CAL.B</i>	-9.000 to 09.000[NTU]	00.000 (NTU)
CODE14	Sensitivity correction factor setting			(See page 6-16)
	Sensitivity correction factor setting	<i>*CAL.K</i>	0.2500 to 4.0000	1.0000
CODE16	Standard solution/check block selection			(See page 6-16)
	Standard solution or check block	<i>*CAL.TP</i>	0, 1	1 :Check Block
CODE17	Check block turbidity setting			(See page 6-16)
	Check block turbidity	<i>*PLATE</i>	0.001 to 2000[NTU]	90.00 (NTU)
CODE30	Analog output range switching parameter setting			(See page 6-18)
	Range switching output selection	<i>*RNGPR</i>	0, 1, 2	0 :Fixed
	Range switching function selection	<i>*RSET</i>	0, 1, 2, 3	1 :Automatic
	Range A setting	<i>*RSET.A</i>		
	Zero point for range A	<i>*ZERO</i>	0000.00 to 2000.00[NTU]	0000.00 (NTU)
	Span point for range A	<i>*SPAN</i>	0000.00 to 2000.00[NTU]	0010.00 (NTU)
	Range B setting	<i>*RSET.B</i>		
	Zero point for range B	<i>*ZERO</i>	0000.00 to 2000.00[NTU]	0000.00 (NTU)
	Span point for range B	<i>*SPAN</i>	0000.00 to 2000.00[NTU]	0100.00 (NTU)
	Range C setting	<i>*RSET.C</i>		
	Zero point for range C	<i>*ZERO</i>	0000.00 to 2000.00[NTU]	0000.00 (NTU)
Span point for range C	<i>*SPAN</i>	0000.00 to 2000.00[NTU]	1000.00 (NTU)	
Automatic range switching point	<i>*AUTOR</i>	070 to 100[%]	080 (%)	
CODE33	Analog output 2 range selection			(See page 6-19)
	Range selection for output 2	<i>*mA2</i>	0, 1	0 :4.0-20.0mA
	Fixed value for hold	<i>*H.mA2</i>	00.0 to 22.0[mA](0-20mA) 02.0 to 22.0[mA](4-20mA)	22.0 (mA)
	Fixed value for hold during failure	<i>*FH.mA2</i>	00.0 to 22.0[mA](0-20mA) 02.0 to 22.0[mA](4-20mA)	22.0 (mA)

Table 5.3 Setting Parameters at the Service Level (2/3)

Code	Setting Parameter	Display	Setting Range	Default
CODE35	Hold during failure parameter setting			(See page 6-20)
	Hold function enabled or disabled	<i>*FHOLD</i>	0, 1	1 : Enabled
	Last measured value, or fixed value	<i>*FH.LST</i> / <i>*FH.FIX</i>	<i>*FH.LST</i> (Last measured value) <i>*FH.FIX</i> (Fixed value)	<i>*FH.FIX</i> :Fixed value
	Fixed value for output 1	<i>*FH.mA1</i>	02.0 to 22.0[mA]	22.0 (mA)
	Fixed value for output 2	<i>*FH.mA2</i>	00.0 to 22.0[mA](0-20mA) 02.0 to 22.0[mA](4-20mA)	22.0 (mA)
CODE37	Time constant setting			(See page 6-20)
	Time constant in measurement	<i>*TC</i>	000 to 120[s]	020 (s)
	Time constant in maintenance	<i>*TC-M</i>	000 to 120[s]	006 (s)
CODE40	Contact output S1 function selection			(See page 6-21)
	Function of contact output S1	<i>*S1</i>	0, 1, 2, 3	1 : Alarm
CODE41	Contact output S2 function selection			(See page 6-21)
	Function of contact output S2	<i>*S2</i>	0, 1, 2, 3	3 : Maintenance
CODE44	Delay time/hysteresis setting			(See page 6-22)
	Delay time	<i>*D.TIME</i>	000 to 199[s]	000 (s)
	Hysteresis	<i>*HYST</i>	000 to 100[%]	002 (%)
CODE50	Auto return function selection			(See page 6-22)
	Auto return function enabled or disabled	<i>*RET</i>	0, 1	0 : Disabled
CODE51	Alarm setting function selection			(See page 6-23)
	Alarm setting function enabled or disabled	<i>*MODE</i>	0, 1	0 : Disabled
CODE52	Password setting			(See page 6-23)
	Password	<i>*PASS</i>	0 to 9	0.0.0
CODE54	Negative nondisplay/nonoutput selection			(See page 6-24)
	Negative nondisplay/nonoutput enabled or disabled	<i>*MINUS</i>	0, 1	0.0 : Disabled. Disabled
CODE61	Turbidity unit selection			(See page 6-24)
	Turbidity unit	<i>*UNIT</i>	0, 1, 2	0 : NTU
CODE64	Software version display			(See page 6-24)
	Software version display	<i>*VER</i>		1.00
CODE66	Error "E2xx" error level selection			(See page 6-25)
	Error levels of errors "E201" to "E206"	<i>*201-6</i>	0, 1, 2	1.1.2.2.2.2
CODE67	Error "E3xx" error detection selection			(See page 6-25)
	Error detection for "E301" to "E306"	<i>*301-6</i>	0, 1	1.1.1.1.1.1
	Error detection for "E307"	<i>*307</i>	0, 1	1
	Error detection for "E311" to "E316"	<i>*311-6</i>	0, 1	1.1.1.1.1.1
	Error detection for "E317"	<i>*317</i>	0, 1	1
CODE71	Analog output test			(See page 6-26)
	Start test for output 1	<i>*AO1.T</i>		
	Test current flowing			
	End	<i>*END</i>		
	Start test for output 2	<i>*AO2.T</i>		
	Test current flowing			
CODE72	Contact output test			(See page 6-27)
	Test 1	<i>*DO.T1</i>	0, 1	Last measured value held
	Test 2	<i>*DO.T2</i>	0, 1	Last measured value held
	Test 1			
	Test 2			
	Test 1			
CODE73	Contact input test			(See page 6-27)
	Test	<i>*DI.T</i>		
CODE79	Initialization			(See page 6-28)
	Start	<i>*LOAD</i>		
	Default loading	<i>*WAIT</i>		

6. PROCEDURES FOR SETTING PARAMETERS

Parameters should be set and function should be selected properly according to application and measurement conditions. This chapter describes the procedures for setting parameters at:

- the operation level
- the setting level
- the service level

6.1 Parameter Setting at the Operation Level

There are calibration, alarm setup and other operation modes at the operation level.

- (1) CAL mode: Calibration, {CALIB}
- (2) DISPLAY mode: Message display selection, {DISP}
- (3) SETPOINTS mode: Alarm setting, {SETP}
- (4) HOLD mode: Hold selection, {HOLD}

This section describes the operating procedures for the above four modes at the operation level.

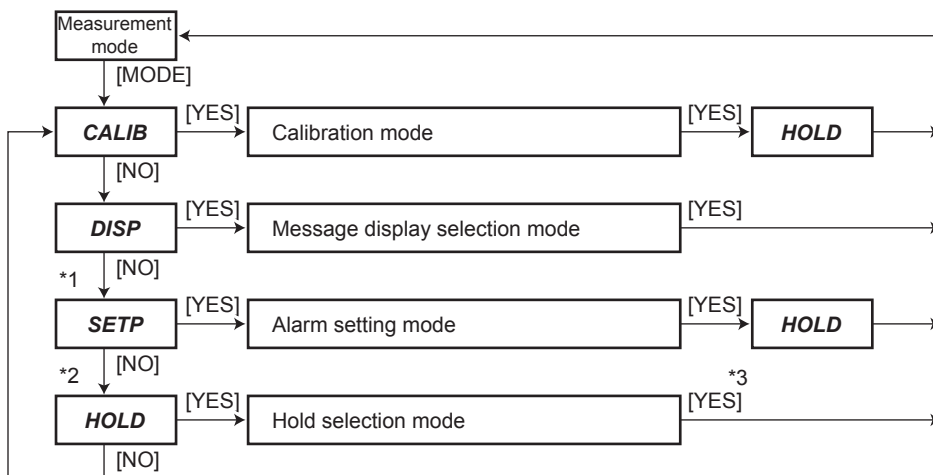

*1: Skipped if alarm setting function is set to "0: Disabled" in Code 51 at service level, or unless either of functions of contact output S1 or S2 is set to "1: Alarm" in Code 40 or 41 at service level.
*2: Skipped if hold function is set to "H.OFF: Disabled" in SET HOLD mode at setting level.
*3: If [YES] key is pressed, analog output is held in measurement mode.

F6-1E.ai

Figure 6.1 Operation Level Flow Chart

(1) CAL Mode: {CALIB}

As for the calibration mode, also refer to Sections 7.6 and 7.7.

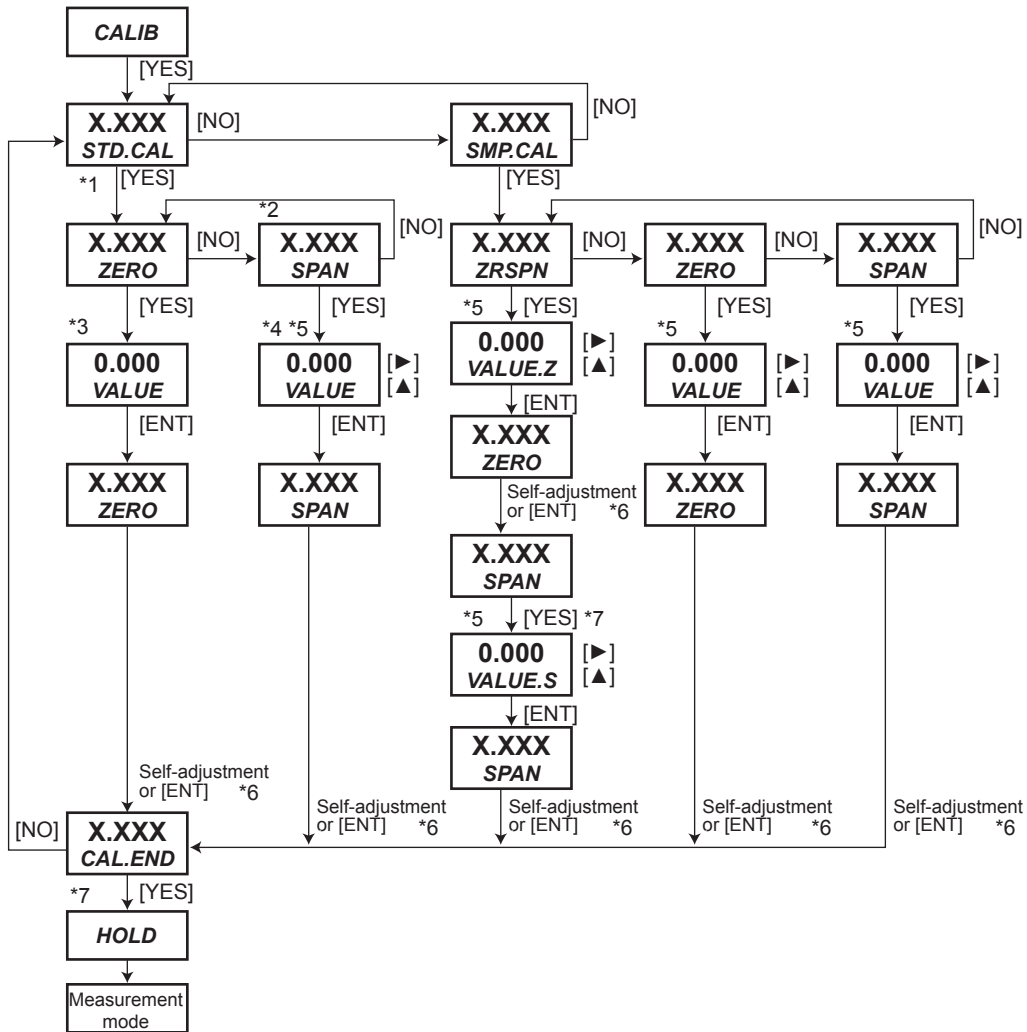

- *1: During the time between [YES] key press on {STD.CAL} display and [YES] or [NO] key press on {CAL.END} display or on error code display or [MODE] key press to abort, data display shows turbidity based on sensitivity correction factor (K)=1 and zero correction factor (B)=0. (Value not affected by SMP.CAL: Display by $T1 = \{(S0 / (SL / 100)) * (V - A)\}$, not by $T2 = K(T1 + B)$)
- *2: Span calibration in {STD.CAL} is performed using turbidity standards or check block that has been selected in CODE16.
- *3: In zero calibration, calibration value should be "0.000" and cannot be changed. Only [ENT] key is accepted to confirm.
- *4: In span calibration using check block, calibration value cannot be changed. Only [ENT] key is accepted to confirm.
- *5: First determine the decimal point using [>] key and then set value in the range of 0.000 to 20000 NTU.
- *6: Pressing [ENT] key during self-adjustment will abort the procedure, and the turbidity when [ENT] key is pressed will be used for calibration factor calculation.
- *7: Only [YES] key is accepted to confirm.

Note: Calibration factor will be updated when the calibration procedure is completed without cancellation or errors. If [YES][NO] key is pressed on error code display, the instrument goes to {CALIB} display. Error E203 or E204 appears after the instrument once returns to measurement display.

F6-2E.ai

Figure 6.2 CAL Mode Flow Chart

Zero/span calibration using Filtered Water as zero reference is generally performed on {STD.CAL} display. (See Equation 6.1.)

2-point calibration using standard solutions is performed on {SMP.CAL}.

If the turbidity measured by the instrument may differ from the one measured manually in a lab due to the difference of properties of the water sample and of turbidity measurement methods, the instrument can be adjusted so that it reads the same value as the one measured in a lab by performing a grab sample calibration on {SMP.CAL} display. In this case, the instrument determines zero and sensitivity correction factors in addition to the calibration factor determined based on the calibration using standards. (See Equation 6.2.)

$T1 = \{S0 / (SL / 100)\} * (V - A)$ Equation 6.1

$T2 = K(T1 + B)$ Equation 6.2

Where:

- T1: Turbidity based on turbidity standards
- S0: Reference sensitivity (reference turbidity standards)
Calculated in CODE 18, reference sensitivity calibration, at service level. This calibration is performed at the factory before shipment.
- SL: Slope, S0/S
Ratio of span calibration factor (S) determined when span calibration is performed using standards to reference sensitivity (S0). The value is displayed in CODE 12 at service level.
- A: Zero calibration factor (reference turbidity standards)
Calculated in zero calibration using standards. The value is displayed in CODE 11 at service level.
- V: Measuring signal, IN1/IN2
Ratio of transmitted light signal (IN1) to front scattered light signal (IN2).
- T2: Turbidity after zero and sensitivity corrections
- K: Sensitivity correction factor
Determined in span calibration using the water sample. The value can be displayed and changed in CODE 14 at service level.
- B: Zero correction factor
Determined in zero calibration using the water sample. The value can be displayed and changed in CODE 13 at service level.

(2) DISPLAY Mode: {DISP}

In this mode, a display item on the message display during measurement can be selected. Each press of the [NO] key cycles through the following three items.

1. {XX.XmA1}: Output current of analog output 1
2. {XX.XmA2}: Output current of analog output 2
3. {RNGX-Y}: Switchable analog output range

When the desired item is shown, press the [YES] key to accept it. The display moves to measurement mode (or hold selection mode). The default is the output current of analog output 1.

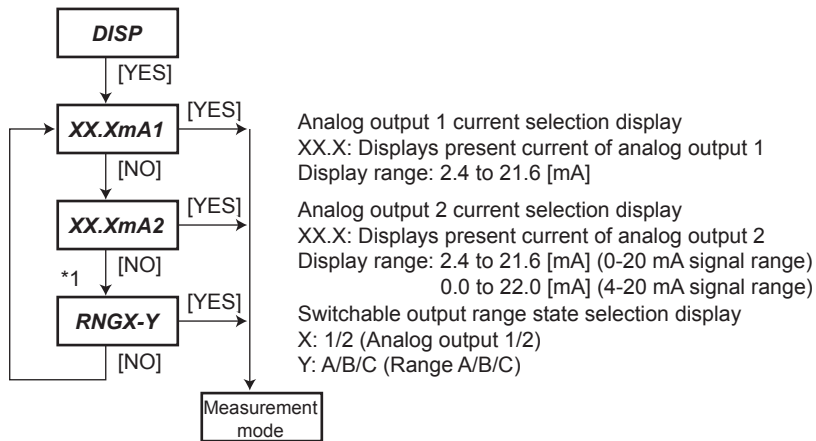

*1: Skipped if analog output range switching selection {*RNGPR} is set to "0: Fixed" in CODE 30 at service level.

F6-3E.ai

Figure 6.3 DISPLAY Mode Flow Chart

(3) SETPOINTS Mode: {SETP}

In this mode, a preset high/low alarm values can be changed. This function is available only when it is set to "Enabled" in CODE 51 at the service level. If the function is set to "Disabled," this mode will be skipped.

Operation in this mode is the same as that in the alarm setting mode at the setting level. See Subsection 6.2 (1) on page 6-7.

Note: The pointer is not shown on the display when this mode is in process.

(4) HOLD Mode: {HOLD}

In this mode whether the analog output is held or not in measurement mode, can be selected. This function is available when the hold function is set to “1: Enabled” in SET HOLD mode at the setting level. If the function is set to “0: Disabled,” this mode will be skipped.

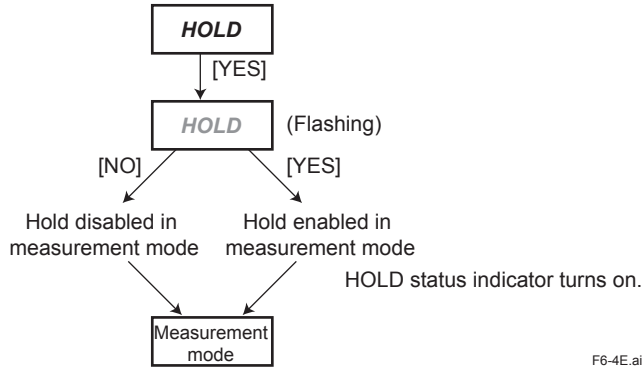

F6-4E.ai

Figure 6.4 HOLD Mode Flow Chart

If the hold function has been set to “1: Enabled” in SET HOLD mode at the setting level, the instrument automatically goes into this HOLD mode when it returns from any level to measurement mode, with the exception of DISPLAY mode.

6.2 Parameter Setting at the Setting Level

At the setting level parameters for output range or other settings can be configured. The function at this setting level will operate based on its set parameters when the function is set to enabled at the service level. Pay attention to the relationship between the mode at the setting level and the related mode at the service level.

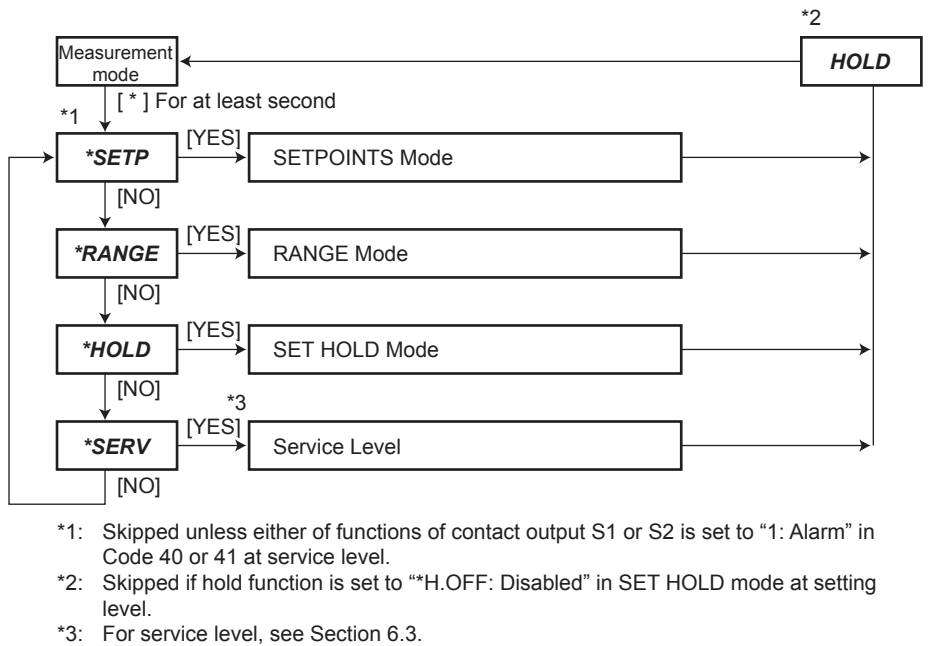

F6-5E.ai

Figure 6.5 Setting Level Flow Chart

There are three setting modes at the setting level:

- (1) SETPOINTS mode: Alarm setting, {*SETP}
- (2) RANGE mode: Analog output range setting, {*RANGE}
- (3) SET HOLD mode: Hold parameter setting, {*HOLD}

This section describes the operating procedures for the above three modes at the setting level in order of mode switching sequence.

(1) SETPOINTS Mode: {*SETP}

In this mode, a high and/or low alarm setpoints can be set. These setpoints are effective when a high/low alarm function is assigned to either one or both of contact outputs S1 and S2 in CODES 40 and/or 41 at the service level. If either of contact output function is not set to "1: Alarm," this mode will be skipped.

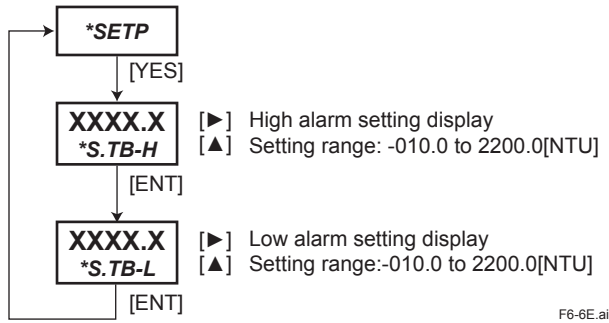

F6-6E.ai

Figure 6.6 SETPOINTS Mode Flow Chart

Note: The alarm function does not work during maintenance or while a level-1 error is occurring.

(2) RANGE Mode: {*RANGE}

In this mode, an output range corresponding to analog output 1 and 2 can be set. Enter turbidity values corresponding to a 4 mA (or 0 mA) output signal (zero point) and a 20 mA output signal (span point).

Enter the values so that the both of the following two conditions are met:

Zero point < span point

Span point - zero point ≥ 20% of span point or 0.20 NTU, whichever is greater.

Failure to meet these conditions will cause error “E351.”

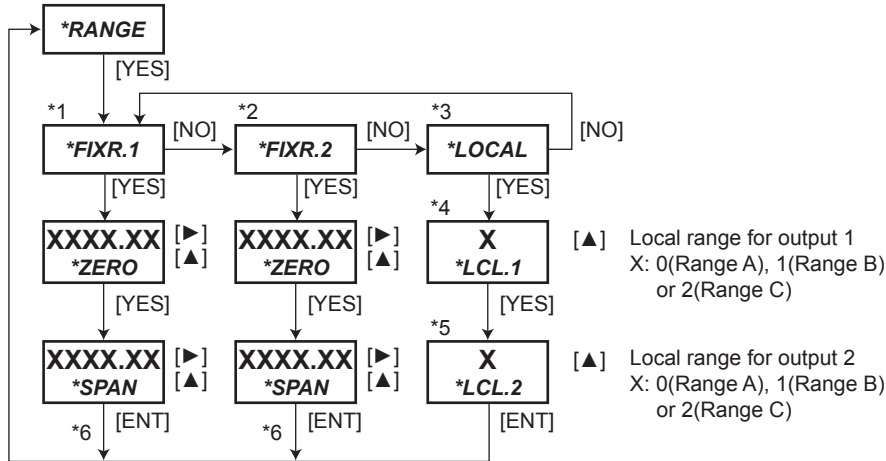

- *1: Skipped if analog output range switching selection {*RNGPR} is set to “1: Analog output 1” in CODE 30 at service level.
- *2: Skipped if analog output range switching selection {*RNGPR} is set to “2: Analog output 2” in CODE 30 at service level.
- *3: Displayed only if analog output range switching selection {*RNGPR} is set to “1: Analog output 1” or “2: Analog output 2” and range switching function selection {*RSET} is set to “0: Manual” in CODE 30 at service level.
- *4: Displayed only if analog output range switching selection {*RNGPR} is set to “1: Analog output 1” in CODE 30 at service level.
- *5: Displayed only if analog output range switching selection {*RNGPR} is set to “2: Analog output 2” in CODE 30 at service level.
- *6: Zero and span points should be set together. Only after span point has been entered, both zero and span points are accepted. Cancellation by pressing [MODE] key during the procedure will not change either of points.

F6-7E.ai

Figure 6.7 RANGE Mode Flow Chart

The setting range and factory default of each item that can be set in this mode are shown below.

Zero point of output 1: {*ZERO}

Setting range: 0000.00 to 2000.00 [NTU]

Factory default: 0000.00 [NTU]

Span point of output 1: {*SPAN}

Setting range: 0000.00 to 2000.00 [NTU]

Factory default: 0100.00 [NTU]

Zero point of output 2 {*ZERO}

Setting range: 0000.00 to 2000.00 [NTU]

Factory default: 0000.00 [NTU]

Span point of output 2: {*SPAN}

Setting range: 0000.00 to 2000.00 [NTU]

Factory default: 1000.00 [NTU]

(3) SET HOLD Mode: {*HOLD}

The following can be set with respect to the output signal hold.

- Whether the hold function is enabled {*H.ON} or disabled {*H.OFF}
- If the function is set to enabled, whether the output signal is held at the last measured value {*H.LST} or a fixed value {*H.FIX}
- If a fixed value is selected, a current value as a fixed value.

When the hold function is set to enabled, the output signal is held during maintenance.

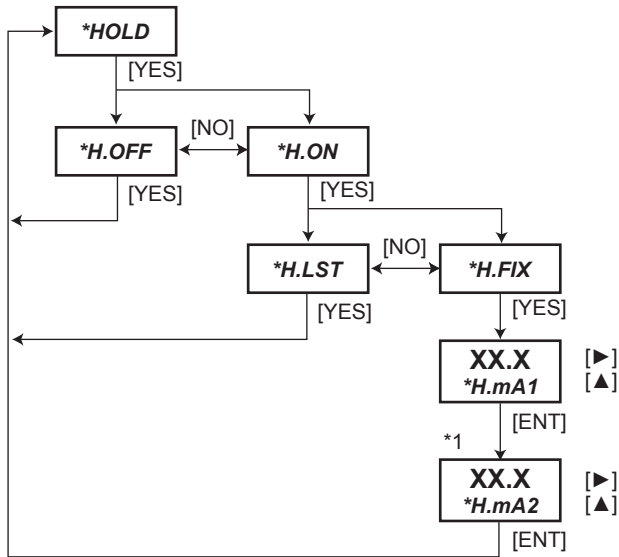

*1: The same display as the one in {*H.mA2} in CODE 35 at service level.

F6-8E.ai

Figure 6.8 SET HOLD Mode Flow Chart

Setting Procedures

- **Selecting Enabled {*H.ON} or Disabled {*H.OFF} for the Hold Function (Factory Default: {*H.ON})**
 1. When the display enters SET HOLD mode, {*H.OFF} or {*H.ON} will appear on the message display.
 2. If the desired option is shown, press the [YES] key. If not, press the [NO] key to toggle to the other option, then press the [YES] key.
 3. When Enabled {*H.ON} is selected here, the hold function starts at this point. Also, the HOLD mode at the operation level is activated; the display automatically goes into the mode when, for example, it returns from the setting or service level to measurement mode. For details, refer to Section 6.1 (4).
- **Selecting the Last Measured Value {*H.LST} or a Fixed Value {*H.FIX} (Factory Default: {*H.LST})**
 1. When Enabled {*H.ON} is selected, {*H.LST} or {*H.FIX} will appear on the message display.
 2. To hold the output signal at the measured value immediately before the hold function is activated, press the [YES] key when {*H.LST} is shown. To hold the output signal at a specified value, press the [YES] key when {*H.FIX} is shown. To toggle two options, press the [NO] key.
- **Setting a Fixed Value for Output 1 {*H.mA1} (Factory Default: 22.0 [mA])**
 1. When a Fixed Value {*H.FIX} is selected, {*H.mA1} will appear on the message display, prompting you to enter a output current value at which the output signal is held.
 2. Change the default value, if necessary, to the desired value using the [>] and [^] keys and press the [ENT] key to accept. If the entered value is outside the setting range: 02.0 to 22.0 mA, error "E352" will occur.
- **Setting a Fixed Value for Output 2 {*H.mA2} (Factory Default: 22.0 [mA])**
 1. When a Fixed Value {*H.FIX} is selected, {*H.mA2} will appear on the message display, prompting you to enter a output current value at which the output signal is held.
 2. Change the default value, if necessary, to the desired value using the [>] and [^] keys and press the [ENT] key to accept. If the entered value is outside the setting range: 02.0 to 22.0 mA for 4-20 mA output; 00.0 to 22.0 mA for 0-20 mA output, error "E352" will occur.

6.3 Parameter Setting at the Service Level

This section describes the setting procedures at the service level in order of code number. Each setting mode at the service level can be accessed by entering the relevant code number.



NOTE

Codes other than listed in Table 5.3 must not be entered. Changing preset parameters may interfere with normal operation of the instrument. As a general rule, if an improper code number is accidentally entered, press the [MODE] key to return to measurement mode.

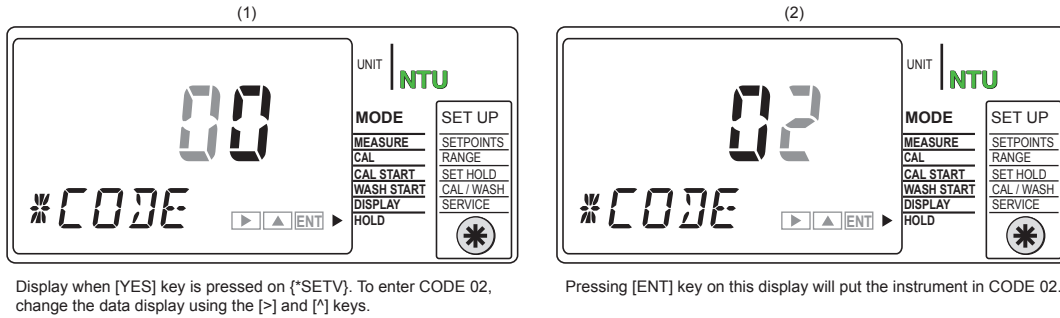

Figure 6.9 Entering a Code Number at the Service Level

CODE 02 Input Voltage Display Mode

Analog input signal values for turbidity measurement, are displayed in volt.

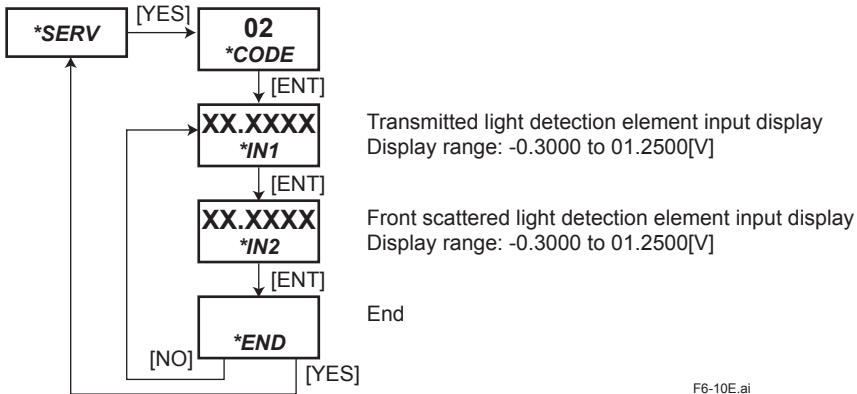

Figure 6.10 Input Voltage Display Mode Flow Chart

Note: This mode is only for displaying the values, not user configurable.

CODE 08 Spike Detection Parameter Setting Mode

The following four parameters in relation to the spike detection function that detect and remove sudden fluctuations in turbidity readings due to air bubbles or others, can be set.

- (1) Selecting enabled/disabled for the spike detection function
- (2) Setting a limit value
- (3) Setting a hold time
- (4) Setting a sampling time

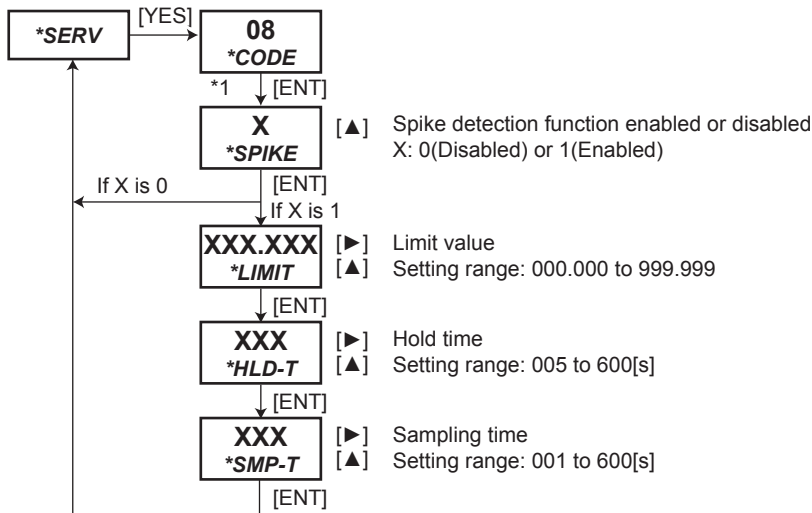

*1: Returns to {*SERV} display if spike detection function is working.

F6-11E.ai

Figure 6.11 Spike Detection Parameter Setting Mode Flow Chart

When the Spike Detection Function is Needed

Air bubbles or dust on the sample surface of the detector's measuring cell at which the light is scattered, can cause fluctuation in turbidity readings; generally a sudden rise in reading occurs. The fluctuation is dependent on the size of air bubbles or dust and their behavior on the sample surface.

It is recommended that a head tank for removing air bubbles be installed. A head tank is for removing air bubbles and thus for preventing them from reaching the detector. In rare cases, however, air bubbles occur and grow in the pipe between the head tank and the detector, and rise to the surface of the measuring cell, resulting in reading fluctuation. The converter has a signal averaging function with a user-configurable averaging factor. Small changes in readings due to air bubbles or dust can be covered to some degree by increasing the time constant. However, it is not good practice to set the time constant too high because it can cause a delay in the response of the turbidity signal.

The spike detection function is to detect and suppress a sudden change due to air bubbles or dust, in turbidity readings and outputs.

How It Functions

To suppress a sudden fluctuation due to air bubbles or dust, the TB750G:

- (1) checks a turbidity signal before averaging;
- (2) calculates the difference between the current signal and the previous signal;
- (3) compares the difference with the Limit Value;
- (4) if it is less than the Limit Value, proceeds to averaging and gives the turbidity reading;
- (5) if it is greater than the Limit Value, holds the output for a specified Hold Time period;
- (6) during that period, suspends the Limit Value check;
- (7) after the Hold Time has elapsed, averages signals without the Limit Value check for a specified Sampling Time period and gives turbidity readings; and,
- (8) after the Sampling Time has elapsed, performs the Limit Value check again.

Instructions for Use

The spike detection function is effective in processes where turbidity changes are relatively small under normal conditions, but it may not be suitable for processes where sudden changes occur often. Even if sudden changes do not usually occur, this function may be activated and may cause a delay in the response of the reading or output if stepwise turbidity changes occur occasionally. Therefore, before using this function carefully consider the process conditions, and in order to use it properly, determine optimum setpoints for the operating conditions while changing them little by little.

When using the function, pay attention to the following.

- (1) Adjust the Limit Value according to the degree of reading change due to air bubbles or dust.
- (2) If an excessively long Hold Time is set, the turbidimeter may not be able to detect a change in reading that may have occurred and should have been recognized as a real change.
- (3) If the function is responsible for the delay in the response of the turbidity reading, try setting the Sampling Time longer without changing the Hold Time.
- (4) When an abnormal turbidity reading is suspected, turn off the function once and wait for a while and see. The function may have prevented the turbidimeter from giving readings properly.

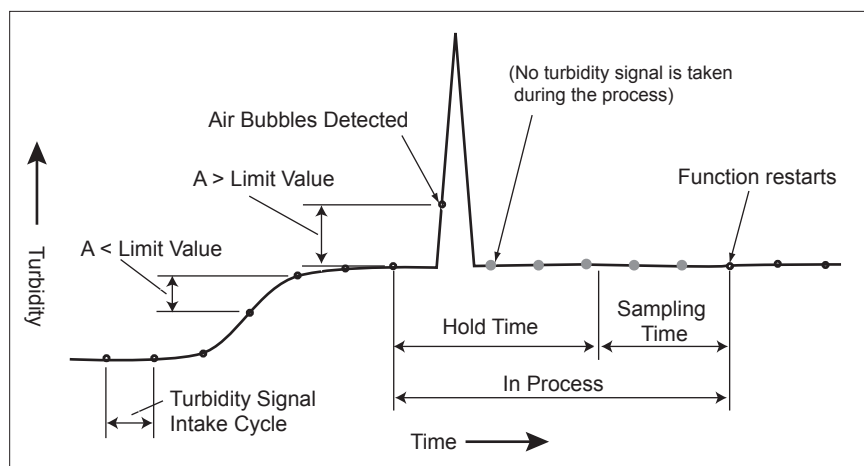

A: Difference between the current signal and the previous signal

F6-12E.ai

Figure 6.12 Spike Detection Function

How to Set Each Parameter

a. Limit Value

A limit value is used to determine whether a reading is a spike due to air bubbles or dust and is defined as a turbidity value in NTU. (The ratio of the sensitivity correction factor is also calculated automatically.)

For the Limit Value check, a pre-averaging turbidity value is used. To determine the Limit Value, it may be needed to know the degree of fluctuation in pre-averaging turbidity signals. Set the time constant for averaging in CODE 37 at the service level to 0 mode to allow the turbidimeter to give turbidity readings directly without averaging. Check readings to know the degree of fluctuation. Generally, the Limit Value is set to a value greater than the fluctuation.

b. Hold Time

When a signal exceeds the Detection Level, the readings and output signals are held for a specified Hold Time. The Hold Time should be long enough for removing air bubbles and dust from the sample surface. Normally, air bubbles and dust will run off the sample surface or disappear within a short time (in a few seconds). In practice, first set the Hold Time to a shorter time, and then increase it if the function does not work satisfactorily.

c. Sampling Time

After the Hold Time has elapsed, the turbidimeter gives readings without any processing for a specified Sampling Time to verify that no fluctuation occurs in turbidity readings. The time count begins after the Hold Time. It is unlikely that air bubbles or dust occur consecutively. Therefore, the Sampling Time may not need to be too short. If the Sampling Time is set too short, the response is delayed when a sudden change in turbidity actually occurs. First set the Sampling Time slightly longer. If something is wrong with the behavior, shorten the time.

Instructions for Use

Be careful when using the function since the following restrictions apply.

- (1) The function works only in measurement mode. As soon as the mode is changed, the Hold or Sampling timer is reset and the function stops.
- (2) During a Hold Time period, both turbidity readings (including communication data) and analog outputs are held.
- (3) The function does not run for approximately 5 seconds right after the turbidimeter is turned on.
- (4) If the turbidimeter is turned off then on again while the function is running, the timer is reset.

CODE 11 Zero Calibration Factor Display Mode

Zero calibration factor A calculated from a zero calibration (zero water), is displayed.

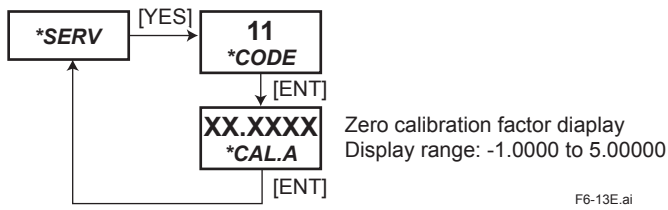

Figure 6.13 Zero Calibration Factor Display Mode Flow Chart

Note: This mode is only for displaying the values, not user configurable.

CODE 12 Slope Display Mode

Slope SL calculated from a span calibration (standard solution or check block), is displayed.

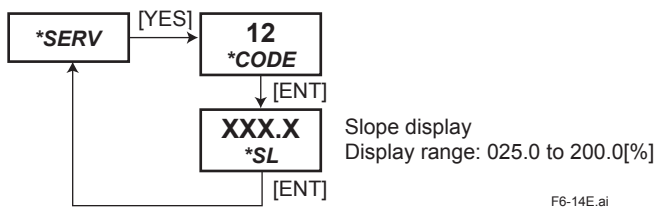

Figure 6.14 Slope Display Mode Flow Chart

Note: This mode is only for displaying the values, not user configurable.

CODE 13 Zero Correction Factor Setting Mode

Zero correction factor B calculated from the 2-point calibration or zero point correction, is displayed. The zero correction factor can also be changed.

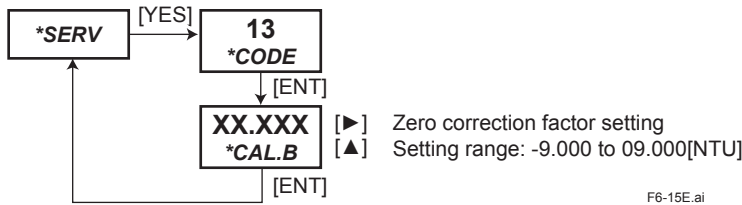

Figure 6.15 Zero Correction Factor Setting Mode Flow Chart

CODE 14 Sensitivity Correction Factor Setting Mode

Sensitivity correction factor K calculated from the 2-point calibration or sensitivity correction, is displayed. The sensitivity correction factor can also be changed.

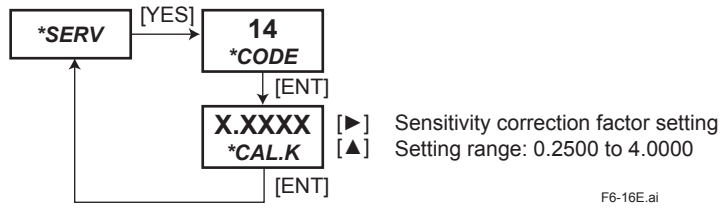

Figure 6.16 Sensitivity Correction Factor Setting Mode Flow Chart

CODE 16 Standard Solution/Check Block Selection Mode

Whether to use a standard solution or check block for span calibration, can be selected.

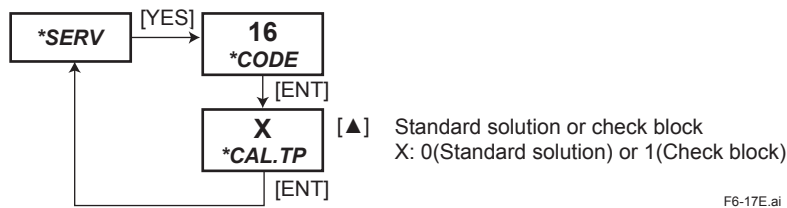

Figure 6.17 Standard Solution/Check Block Selection Mode Flow Chart

CODE 17 Check Block Turbidity Setting Mode

A turbidity value of the check block used for span calibration, can be set.

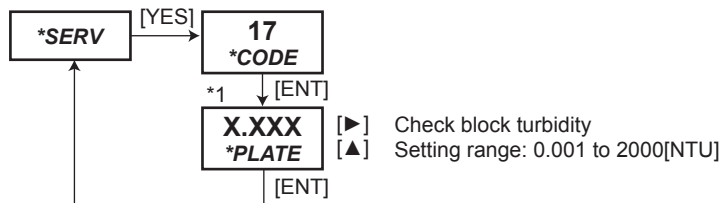
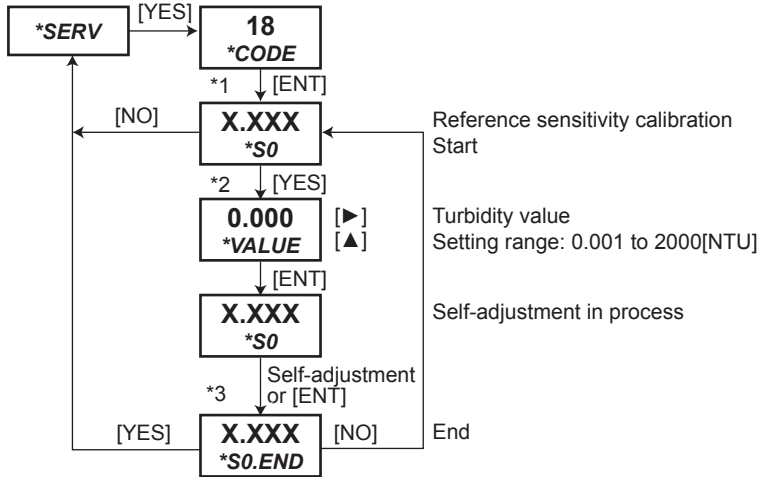

Figure 6.18 Check Block Turbidity Setting Mode Flow Chart

CODE 18 Reference Sensitivity Calibration Mode

This mode is for determining reference sensitivity S0 in calibration using turbidity standards that is performed at the factory before shipment. (Refer to Section 6.1 (1).) This mode should not be accessed in the field. The reference sensitivity, however, needs to be calibrated if the sensitivity is changed, for example, after optical components have been replaced due to the hardware failure, and the sensitivity cannot be adjusted in the normal calibration using standards. In that case, be sure to contact our Service.



- *1: During the time between the start and the end of the CODE 18 procedure, data display shows turbidity based on sensitivity correction factor K=1 and zero correction factor B=0.
- *2: First determine decimal point using [>] key and the set the value.
- *3: Pressing [ENT] key during self-adjustment will abort the procedure and the turbidity when [ENT] key is pressed will be used for calibration factor calculation.

Note: Calibration factor will be updated when the calibration procedure is completed without cancellation or errors. Cancellation or error before the display shows { *S0.END } will not update the factor. F6-19E.ai

Figure 6.19 Reference Sensitivity Calibration Mode Flow Chart

CODE 30 Analog Output Range Switching Parameter Setting Mode

Various parameters in relation to the analog output range switching function, can be set.

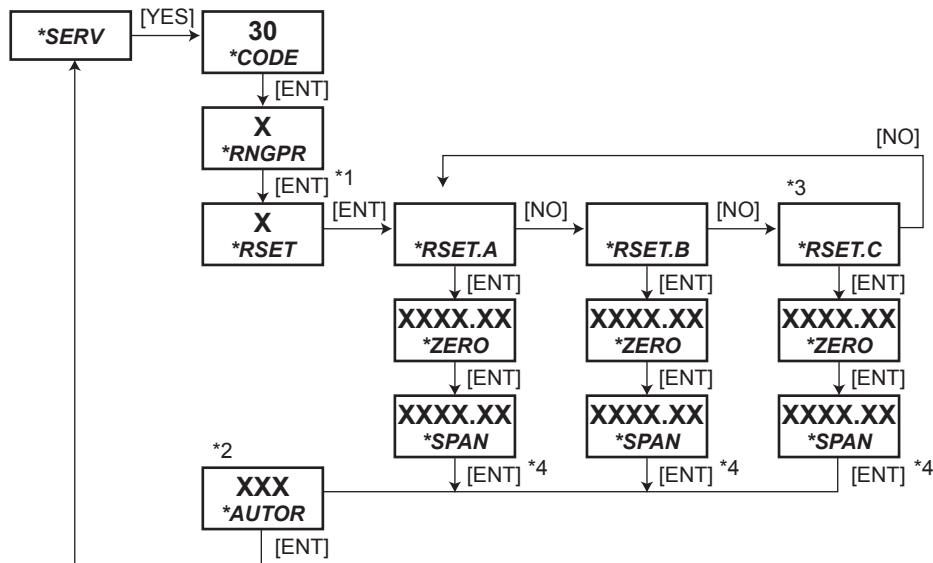

*1: Returns to {*SERV} display if {*RNGPR} is set to "0: Fixed."

*2: Displayed only if {*RSET} is set to "1: Automatic."

*3: Skipped if {*RSET} is set to "2: Remote 2 range."

*4: Zero and span points should be set together. Only after span point has been entered, both zero and span points are set. Cancellation by pressing [MODE] key during the procedure will not change either of points.

F6-20E.ai

Figure 6.20 Analog Output Range Switching Parameter Setting Mode Flow Chart

***RNGPR: Range switching output selection display**

Set "0" (fixed), "1" (analog output 1) or "2" (analog output 2) using [^] key.

***RSET: Range switching function selection display**

Set "0" (manual), "1" (automatic), "2" (remote 2 range) or "3" (remote 3 range) using [^] key.

***RSET.A (or B or C): Analog output range A (or B or C) initial setting display**

***ZERO: Range A (or B or C) zero point setting display**

Set the desired value within the range of 0000.00 to 2000.00 [NTU] using [^] and [>] keys.

***SPAN: Range A (or B or C) span point setting display**

Set the desired value within the range of 0000.00 to 2000.00 [NTU] using [^] and [>] keys.

Instructions for Setting Zero and Span Points

1. Zero point < span point
2. Span point – zero point ≥ 20% of span point or 0.20 NTU, whichever is greater
3. Span point of Range A < span point of Range B < span point of Range C

If the keyed-in value is outside the setting range, error "E351" (improper analog output range setting) will occur.

***AUTOR: Automatic range switching point setting display**

Set the desired value within the range of 070 to 100 [%] using [^] and [>] keys.

If the entered value is outside the setting range, error “E352” (improper range setting) will occur.

Switching Point

- The converter will switch from the low range to the high range when the turbidity value exceeds the switching point of the low range.
- The converter will switch from the high range to the low range when the turbidity value lowers 10% from the switching point of the low range.

CODE 33 Analog Output 2 Range Selection Mode

The analog output 2 signal range can be selected.

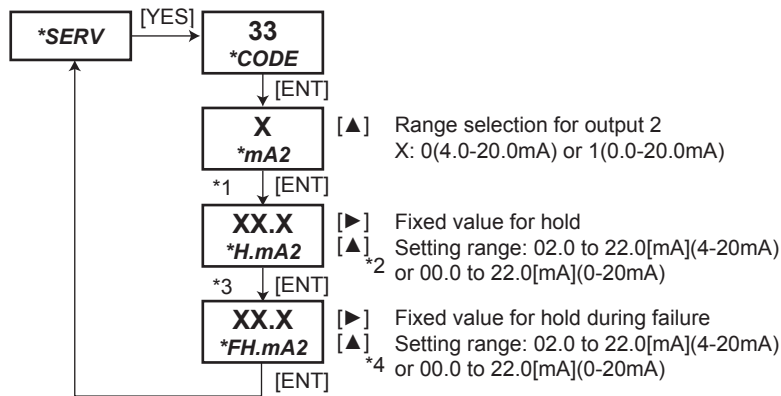

- *1: Displayed only if hold function is set to “*H.ON: Enabled” and fixed value {*H.FIX} is selected in SET HOLD mode at setting level.
- *2: The same display as the one in {*H.mA2} in SET HOLD mode at setting level.
- *3: Displayed only if {*FHOLD} is set to “1: Enabled” and fixed value {*FH.FIX} is selected in CODE 35 at service level.
- *4: The same display as the one in {*FH.mA2} in CODE 35 at service level.

F6-21E.ai

Figure 6.21 Analog Output 2 Range Selection Mode Flow Chart

CODE 35 Hold During Failure Parameter Setting Mode

This mode is activated only when a failure occurs. The following three parameters in relation to the analog output hold function when a failure occurs, can be set.

- (1) Selecting enabled or disabled for the hold function
- (2) Selecting the last measured value or a fixed value
- (3) Setting a fixed value for analog outputs 1 and 2, respectively

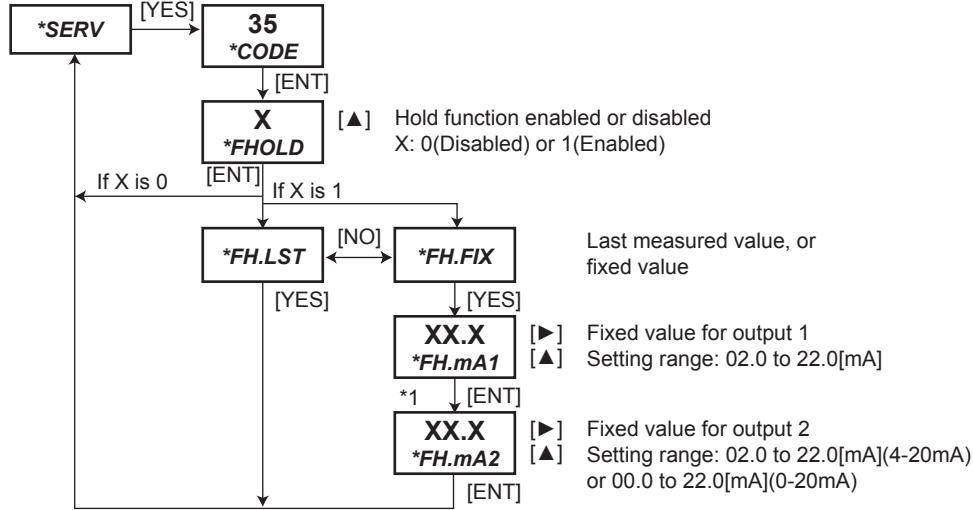

*1: The same display as the one in {*FH.mA2} in CODE 33 at service level.

F6-22E.ai

Figure 6.22 Hold During Failure Parameter Setting Mode Flow Chart

CODE 37 Time Constant Setting Mode

If the control action or the like is disturbed by fluctuation of measured value, the fluctuation in output signal can be smoothed by setting an appropriated time constant (63% response time).

In measurement mode, the time constant set in time constant in measurement display is used; in maintenance mode, the one set in time constant in maintenance display is used.

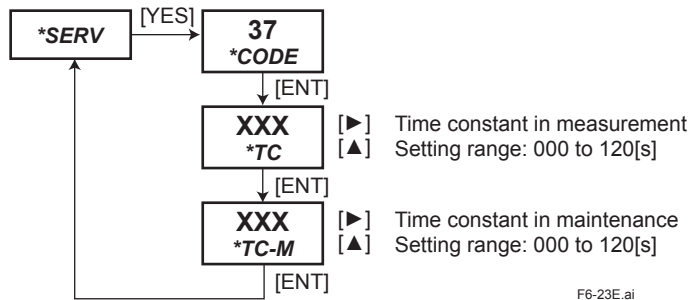

F6-23E.ai

Figure 6.23 Time Constant Setting Mode Flow Chart

CODE 40 Contact Output S1 Function Selection Mode

A function assigned to contact output S1 can be selected. Note that an option not available in the specifications will not start even if selected.

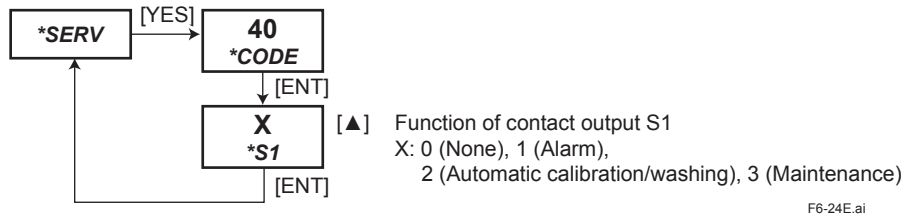

Figure 6.24 Contact Output S1 Function Setting Mode Flow Chart

CODE 41 Contact Output S2 Function Selection Mode

A function assigned to contact output S2 can be selected. Note that an option not available in the specifications will not start even if selected.

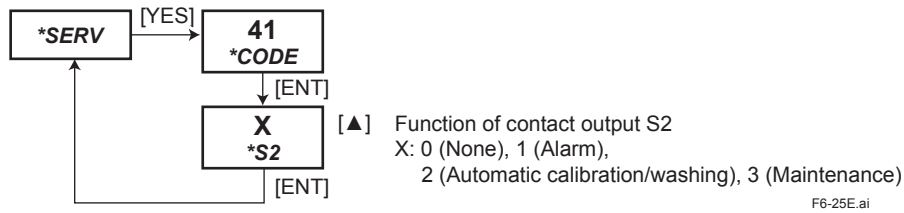

Figure 6.25 Contact Output S2 Function Selection Mode

CODE 44 Delay Time/Hysteresis Setting Mode

If the turbidity value crosses the high/low alarm setpoint rapidly, the alarm output will be switched rapidly. To prevent this, the following two parameters should be set.

- (1) A delay time
- (2) A hysteresis

Delay Time and Hysteresis for High/Low Alarm Contact Output

The alarm contact output is activated when a specified delay time elapses after the turbidity value has crossed the high/low alarm setpoint, not immediately after the turbidity value has crossed the setpoint. The output will be deactivated when the delay time elapses after the turbidity value has crossed the setpoint minus/plus a specified hysteresis. If the turbidity value goes above/below the setpoint minus/plus the hysteresis during the delay time, the delay time will be reset.

The delay time and hysteresis are available when a high/low alarm function is assigned to either of contact outputs S1 and S2. The hysteresis is defined as a percentage of the high alarm setpoint.

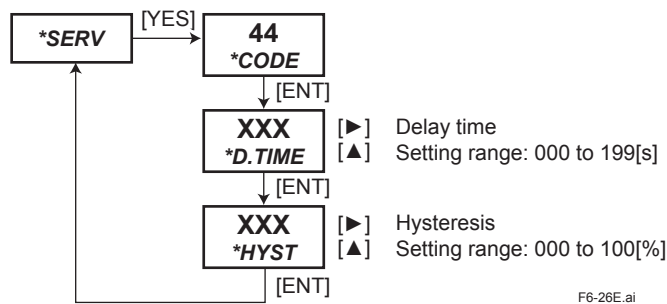

Figure 6.26 Delay Time/Hysteresis Setting Mode Flow Chart

CODE 50 Auto Return Function Selection Mode

Whether the auto return function is enabled or disabled, can be selected. The auto return function is that the instrument will automatically return to measurement mode if no keys are operated for 10 minutes in each level, with exception of calibration mode.

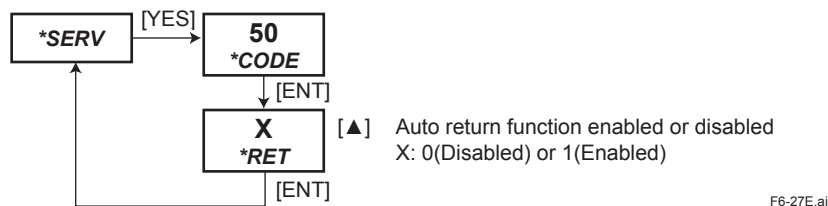
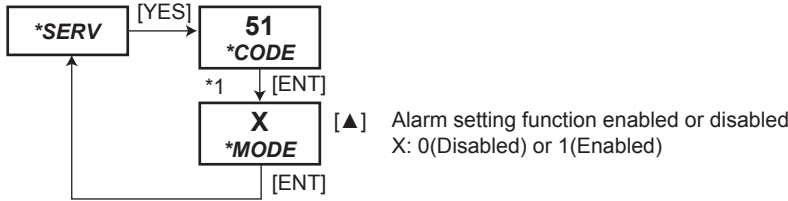

Figure 6.27 Auto Return Function Selection Mode Flow Chart

CODE 51 Alarm Setting Function Selection Mode

If Enabled is selected in this mode, the SETPOINTS mode can also be accessed from the operation level. The alarm setting mode is normally at setting level. Note that the pointer is not shown on the display when this mode at operation level is in process.



*1: Skipped unless either of functions of contact output S1 or S2 is set to "1: Alarm" in Code 40 or 41 at service level. Pressing [ENT] key in CODE 51 will return the instrument to { *SERV } introduction display.

F6-28E.ai

Figure 6.28 Alarm Setting Function Selection Mode Flow Chart

CODE 52 Password Setting Mode

A password can be set for each three level – the operation, setting and service levels – to prevent unauthorized access. A password can be selected for each level, respectively, from among nine options. If a password has been set, the level cannot be accessed without entering the relevant password.

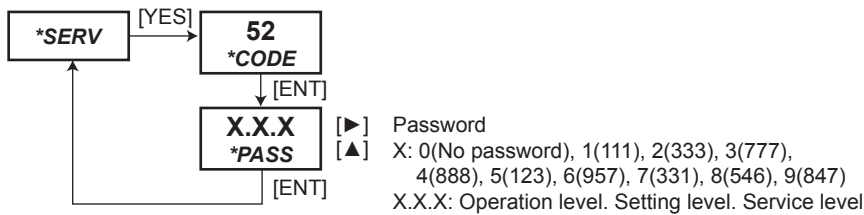

F6-29E.ai

Figure 6.29 Password Setting Mode Flow Chart

Password Prompt

If a password has been set, a password prompt will appear:

- in the operation level, when the [MODE] key is pressed in measurement mode;
- in the setting level, when the [*] key is pressed;
- in the service level, when the [YES] key is pressed with { *SERV } shown on the display.

See Section 5.1.3.

CODE 54 Negative Nondisplay/Nonoutput Selection Mode

Whether the negative nondisplay and/or negative nonoutput functions are enabled or disabled, can be selected.

If the negative nondisplay function is enabled, a negative turbidity reading will be hidden and a fixed "0" will be shown instead on both data and message displays. This function does not affect the analog output; a negative output value will be shown.

If the negative nonoutput function is enabled, a value of analog output 1 or 2 will be fixed at "0" when it goes negative. This function does not affect the reading; a negative reading will be shown.

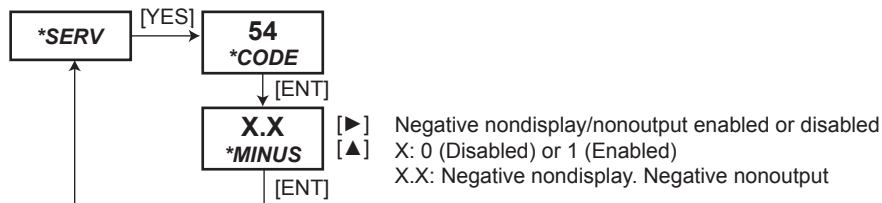

F6-30E.ai

Figure 6.30 Negative Nondisplay/Nonoutput Selection Mode Flow Chart

CODE 61 Turbidity Unit Selection Mode

A turbidity unit (lamp indication on the front panel) can be selected from among NTU, FNU, or mg/l.

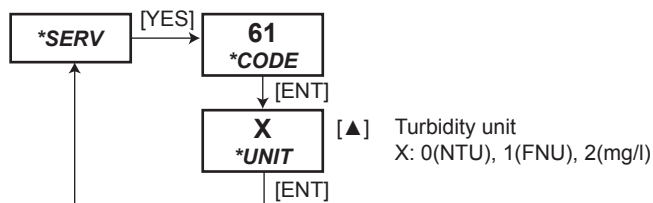

F6-31E.ai

Figure 6.31 Turbidity Unit Selection Mode Flow Chart

CODE 64 Software Version Display Mode

The software version number is displayed.

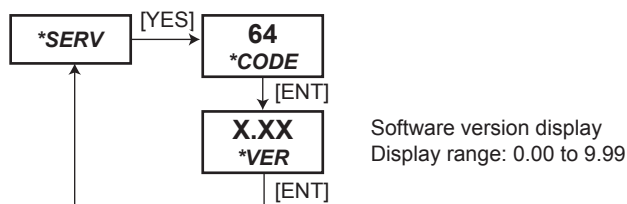

F6-32E.ai

Figure 6.32 Software Version Display Mode Flow Chart

Note: This mode is only for displaying the values, not user configurable.

CODE 66 “E2xx” Error Level Selection Mode

An error level of errors “E2xx” can be selected, respectively. A changed error level of the error is valid from the next occurrence of the error.



- * Disabled: Error detection function disabled, Level 1: Severe error, Level 2: Moderate error (For details, See Chapter 8.)
- ** Settings for reserved error code (E206) is invalid.

F6-33E.ai

Figure 6.33 “E2xx” Error Level Selection Mode Flow Chart

CODE 67 “E3xx” Error Detection Selection Mode

The error detection function can be set to enabled or disabled for error “E3xx,” respectively. Note that error levels of “E321,” “E351” and “E352” are exclusions. The error level for error “E3xx” is fixed to level 3 (minor error).

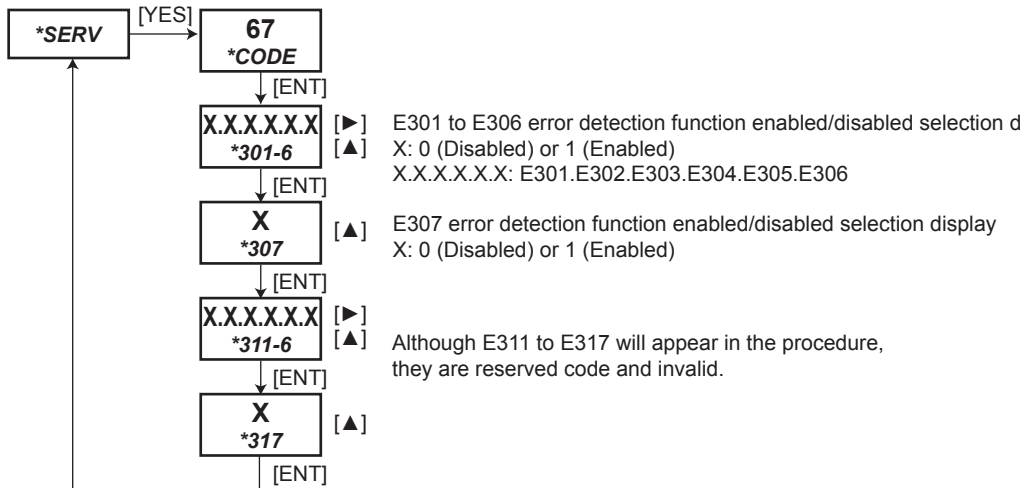

F6-34E.ai

Figure 6.34 “E3xx” Error Level Selection Mode Flow Chart

CODE 71 Analog Output Test Mode

A test current value is output to analog outputs 1 and 2. Refer to Section 7.9 (1).

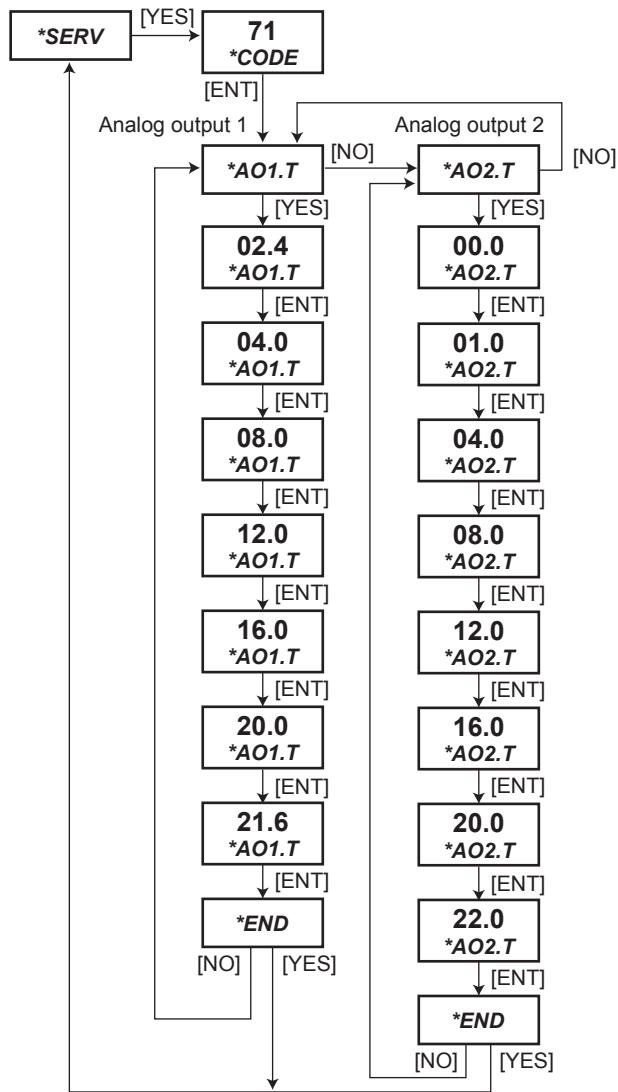

F6-35E.ai

Figure 6.35 Analog Output Test Mode Flow Chart

CODE 72 Contact Output Test Mode

In this mode the operation of each contact output can be checked. Refer to Section 7.9 (2).

On test display 1, the operation of contact outputs (S1, S2, FAIL) and range contact outputs (ranges A, B, C) can be checked. During the contact output (S1, S2, FAIL) check, the corresponding contact status LED should turn on.

On test display 2, the operation of contact output for power on/off of the ultrasonic oscillator and communication can be checked.

Note: Settings for unused contact are invalid.

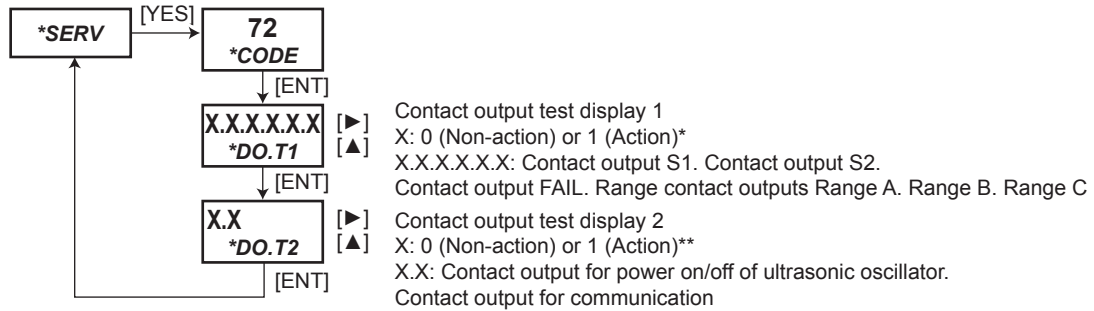

- * FAIL contact will open (deenergized) when in action, while S1, S2, and range contact will be closed (energized) when in action.
- ** Contact output for power on/off of ultrasonic oscillator will be closed (energized) when in action. Contact output for communication will open (deenergized) when in action (reset).

F6-36E.ai

Figure 6.36 Contact Output Test Mode Flow Chart

CODE 73 Contact Input Test Mode

The current contact input state is displayed. Refer to Section 7.9 (3).

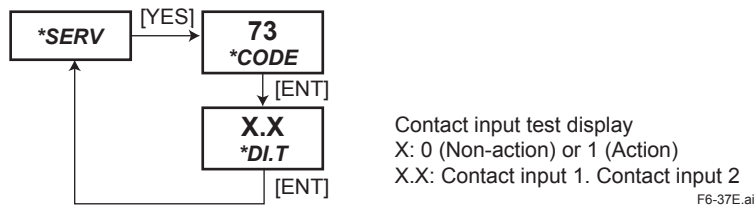

F6-37E.ai

Figure 6.37 Contact Input Test Mode Flow Chart

CODE 79 Initialization Mode

Parameters are collectively initialized to the defaults. To execute, enter a password of "709." The factory defaults are provided in an Operation Parameter Setting List at the end of this manual.

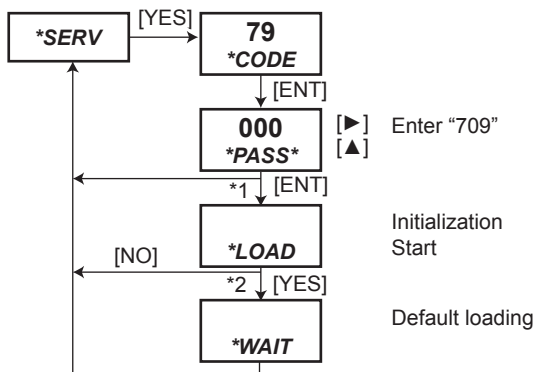

- *1: { *LOAD } will appear only if correct password is entered. Otherwise, the display will return to { *SERV }.
- *2: Pressing [YES] key on { *LOAD } display will start initialization to the defaults and "WAIT" is shown during the process. After completion, the display will automatically return to { *SERV }.

F6-38E.ai

Figure 6.38 Initialization Mode Flow Chart

7. MAINTENANCE

This chapter describes the inspection and maintenance required to keep the instrument in good operating condition.

7.1 Inspection/Maintenance Items and Intervals

The main inspection/maintenance items and their recommended intervals to keep the instrument in good operating condition, are provided in Table 7.1. Since the frequency of inspection/maintenance depends on the operating conditions, use the recommended intervals shown in Table 7.1 as a reference and perform inspection/maintenance at appropriate intervals.

Table 7.1 Inspection/Maintenance Items and Recommended Intervals

Inspection/Maintenance Item	Recommended Interval
Removal of sediment from measurement cell	As needed
Washing of measurement cell	Weekly
Washing of head tank	Monthly
Lamp replacement	Yearly
Calibration using turbidity standards	Monthly
Grab sample calibration	As needed
Checking and replacing desiccants	Monthly
Replacement of zero turbidity filter element	Yearly*
Fuse replacement	Yearly
Pipe cleaning	6 months
Cleaning of front covers of detector/converter	As needed

* This is an interval estimated if tap water used has an average turbidity of 0.4 NTU and runs at a flow rate of 2 l/min.

7.2 Removing Sediment from the Measurement Cell

If the turbidity of a water sample is high, suspended matter may settle to the bottom of the measurement cell. Remove the rubber cover from the top of the detector and visually check the measurement cell from the observation window. If sediment is visible, open and close the drain valve after the detector at least three times to remove the sediment.

- (1) Putting the converter in the maintenance state.
 1. Press the [MODE] key on the converter. Check the {CALIB} is shown on the message display.
 2. Press the [NO] key repeatedly. The message display should show {HOLD}. Press the [YES] key to enter analog output hold selection mode.
 3. Check that {HOLD} is flashing on the message display. Press the [YES] key to put the converter in the maintenance state (analog output signal is held). The HOLD indicator turns on.

Note: If the analog output hold function has been set to Disabled {*H.OFF} in SET HOLD mode at the setting level, steps 2 and 3 cannot be done. If analog output should be held during maintenance, select Enabled {*H.ON}. (The factory default is Enabled {*H.ON}.)

- (2) Remove the rubber cover from the top of the detector and visually check the measurement cell from the observation window for sediment.

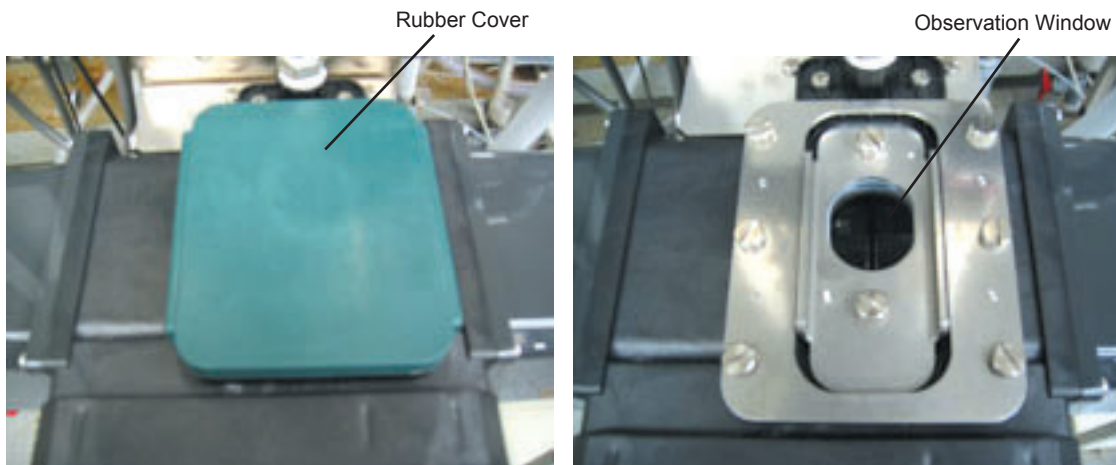

F7-1E.ai

Figure 7.1 Top of the Detector

- (3) If sediment is visible, open the drain valve after the detector to drain the water sample from the measurement cell.
- (4) Close the drain valve.
- (5) Repeat steps (3) and (4) at least three times, depending on the degree of sediment.
- (6) Visually check from the observation window that the measurement cell is filled with the water sample. Attach the rubber cover to the top of the detector.
- (7) Putting the converter in measurement mode.
 1. Press the [MODE] key on the converter. Check that the message display shows {CALB}.
 2. Press the [NO] key repeatedly until {HOLD} appears on the message display. Press the [YES] key to enter analog output hold selection mode.
 3. Check that {HOLD} is flashing on the message display. Press the [NO] key to exit from the maintenance state (analog hold is held) and return to measurement mode. The HOLD indicator turns off.
- (8) Sediment removal is now complete.

7.3 Washing the Measurement Cell

The measurement cell and window should be washed with mild detergent.

- (1) Putting the converter in the maintenance state.
 - 1. Press the [MODE] key on the converter. Check the {CALIB} is shown on the message display.
 - 2. Press the [NO] key repeatedly. The message display should show {HOLD}. Press the [YES] key to enter analog output hold selection mode.
 - 3. Check that {HOLD} is flashing on the message display. Press the [YES] key to put the converter in the maintenance state (analog output signal is held). The HOLD indicator turns on.

Note: If the analog output hold function has been set to Disabled {H.OFF} in SET HOLD mode at the setting level, steps 2 and 3 cannot be done. If analog output should be held during maintenance, select Enabled {H.ON}. (The factory default is Enabled {H.ON}.)

- (2) Draining the water sample.
 - 1. Close the sample water supply valve.
 - 2. Open the drain valve after the detector to drain the water sample.
- (3) Washing the measurement cell.
 - 1. Open the zero water supply valve to supply zero water to the detector.
 - 2. Close the drain valve. When the measurement cell is filled with the zero water, open the drain valve to drain.
 - 3. Repeat steps 1 and 2 at least three times.
- (4) Leave the drain valve open.
- (5) Remove the rubber cover from the top of the detector. Remove the detector top cover by loosening the 6 setscrews.

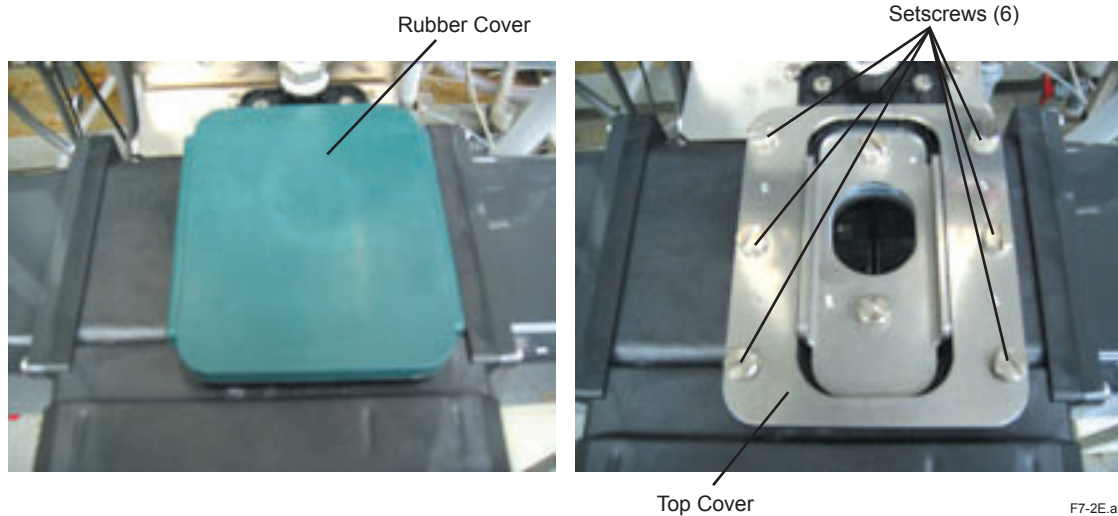

Figure 7.2 Top Cover of the Detector

F7-2E.ai

- (6) Thoroughly wash the inside of the measurement cell using a sponge or soft cloth soaked in mild detergent. Next, carefully wash the 3 glass windows using a brush or a sponge or soft cloth with cream cleanser. Rinse the inside with zero water (or tap water), as needed.

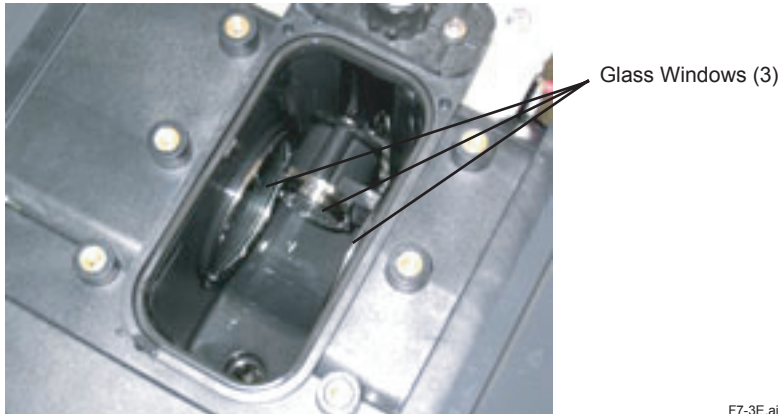

Figure 7.3 Inside the Detector Measurement Cell

- (7) Replace the top cover on the top of the detector and tighten the 6 setscrews.
- (8) Supply zero water to the detector. When the measurement cell is filled with the water, drain it. Repeat this at least three times to thoroughly rinse off detergent in the measurement cell. See step (3) for valve operation.
- (9) Replace the rubber cover on the detector top cover.
- (10) Putting the converter in measurement mode.
1. Press the [MODE] key on the converter. Check that the message display shows {CALB}.
 2. Press the [NO] key repeatedly until {HOLD} appears on the message display. Press the [YES] key to enter analog output hold selection mode.
 3. Check that {HOLD} is flashing on the message display. Press the [NO] key to exit from the maintenance state (analog hold is held) and return to measurement mode. The HOLD indicator turns off.
- (11) Washing is now complete.

7.4 Washing the Head Tank

This section describes the procedure for washing the head tank.

- (1) Putting the converter in the maintenance state.
 1. Press the [MODE] key on the converter. Check the {CALIB} is shown on the message display.
 2. Press the [NO] key repeatedly. The message display should show {HOLD}. Press the [YES] key to enter analog output hold selection mode.
 3. Check that {HOLD} is flashing on the message display. Press the [YES] key to put the converter in the maintenance state (analog output signal is held). The HOLD indicator turns on.

Note: If the analog output hold function has been set to Disabled {H.OFF} in SET HOLD mode at the setting level, steps 2 and 3 cannot be done. If analog output should be held during maintenance, select Enabled {H.ON}. (The factory default is Enabled {H.ON}.)

- (2) Close the sample water supply valve.
- (3) Draining water from the head tank and washing it.

The following describes how to wash two optional head tanks provided by Yokogawa.

[Pressurized head tank]

1. Close the sample water valve.
2. Loose and remove the drain plug attached to the side of the head tank, to drain the water sample.
3. Remove the cover on the top of the head tank. Wash inside the tank using a sponge or soft cloth soaked in mild detergent. Pour tap water into the tank from above and rinse off thoroughly.
4. Replace the drain plug and the top cover.
5. Open the sample water valve to run the water sample into the head tank and wait until the tank is refilled.

[Simple head tank]

With the sample water valve open, open and close the drain valve under the head tank at least three times to rinse out the head tank.

- (4) After washing the head tank, open the sample water supply valve to supply the water sample to the detector.
- (5) Putting the converter in measurement mode.
 1. Press the [MODE] key on the converter. Check that the message display shows {CALB}.
 2. Press the [NO] key repeatedly until {HOLD} appears on the message display. Press the [YES] key to enter analog output hold selection mode.
 3. Check that {HOLD} is flashing on the message display. Press the [NO] key to exit from the maintenance state (analog hold is held) and return to measurement mode. The HOLD indicator turns off.
- (6) Washing is now complete.

7.5 Lamp Replacement



CAUTION

Wait for some time to replace lamp assembly because lamp temperature is high just after lamp power was turned off.

Although the lamp has a normal service life of more than one year, it is recommended that the lamp be replaced at an interval of one year in terms of preventive maintenance. Some lamps may fail within one year.

The following describes how to replace the lamp.

- (1) Remove power from the TB750G turbidimeter.
- (2) Remove the cover of the light source unit on the left side of the detector by loosening the 4 setscrews.
- (3) Disconnect the terminals for lamp from the terminal block. Remove the lamp assembly by loosening the 2 setscrews.
- (4) Replace the lamp assembly with a new one. Mount the new lamp assembly with the 2 setscrews. Connect the terminals for lamp to the terminal block (LAMP).
- (5) Supply power to the TB750G turbidimeter.
- (6) Check that the lamp is lit. Replace and fix the cover of the light source unit by tightening the 4 setscrews.
- (7) After the lamp replacement, allow the turbidimeter to warm up for at least one hour. Then, perform calibrations instructed in Sections 7.6 to 7.8.
- (8) Lamp replacement is now complete.

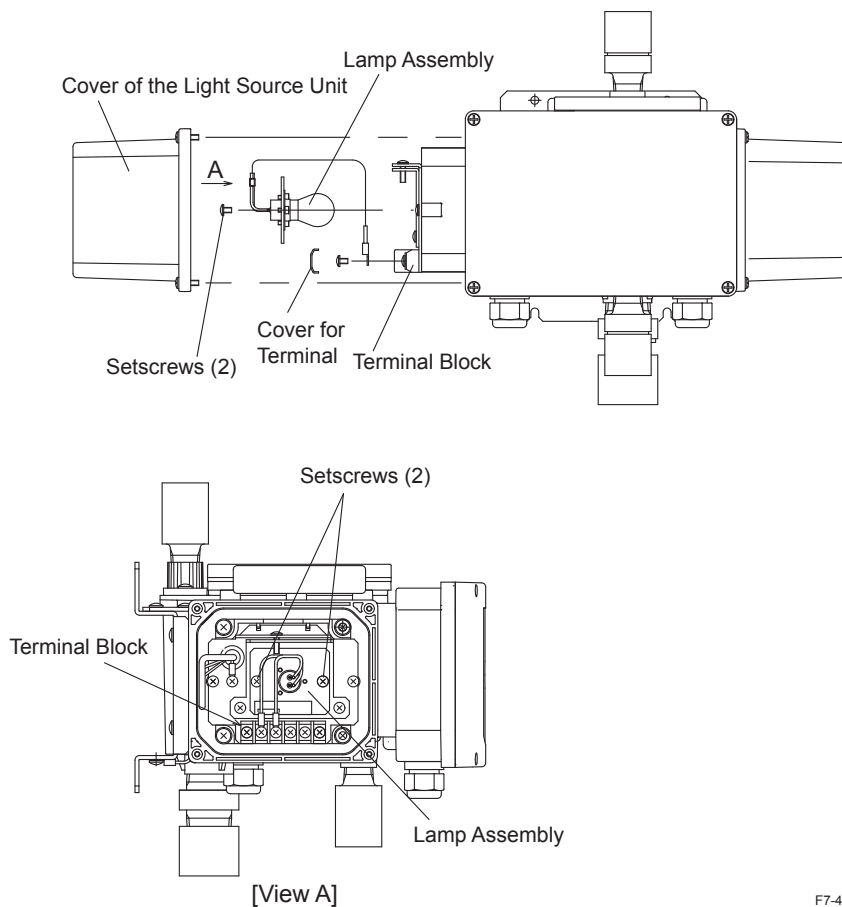

Figure 7.4 Lamp Replacement

F7-4E.ai



NOTE

Do not touch any other parts, which are fixed by enamel paint, except lamp setscrews to prevent optical alignment from changing.

7.6 Calibration Using Turbidity Standards

Calibration using turbidity standards for the TB750G should be performed:

- before starting operation the very first time, and before restarting after long downtime;
- after the lamp has been replaced;
- a measurement error exceeds the tolerance; and,
- at the regular maintenance work (monthly).

There are some calibration methods, as shown in Figure 7.5, for the calibration using turbidity standards.

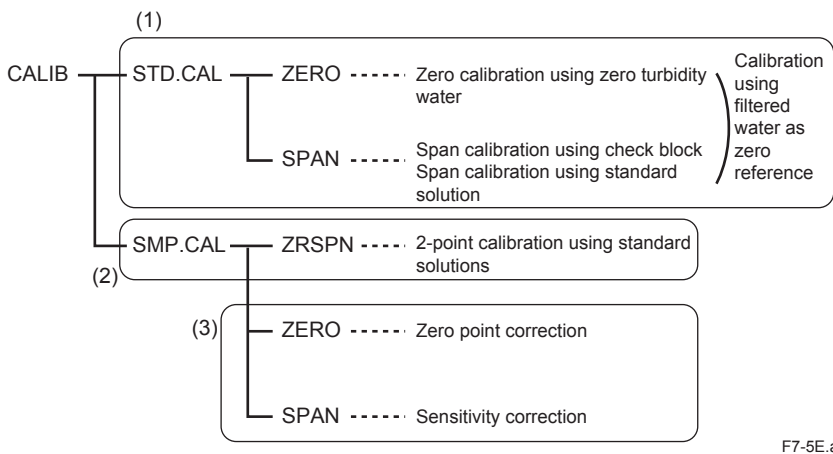

F7-5E.ai

Figure 7.5 Calibration Methods

- (1) Select when performing a calibration using 0.2 or 1.0 µm filtered water as zero reference.
- (2) Select when performing a 2-point calibration using standard solutions. Use this method to perform a calibration complying with EPA METHOD 180.1. (Refer to Section 7.7, "2-point Calibration Using Standard Solutions")
- (3) Select when performing a zero point or sensitivity correction after calibration (1) or (2). This method is a calibration using the water sample to adjust the meter reading to reflect the lab data. (Refer to Section 7.8, "Grab Sample Calibration.")

Note: The instrument has been pre-calibrated using 0.2 µm filtered water as zero reference at the factory before shipment.

The following illustrates the concept of the above calibration methods.

<Concept of Calibrations>

Legend:

---/○ : Before calibration Meas: Measured value
 —/● : After calibration Std: Turbidity standard
 SW: Sample water
 All numbers in figures are examples.

STD.CAL	ZERO		Zero calibration using zero turbidity water (0.2/1 μm filtered water as zero reference) • Not accept values other than 0. • Calculates -A to change calibration factor.
	SPAN		Span calibration using check block/standard solution • Calibrates so the instrument has reference sensitivity at the time of factory shipment. • Displays the value of check block if "1 (Check block)" is specified in CODE 16 at the service level.
SMP.CAL	ZRSPN		2-point calibration using calibration solutions • Not use filtered water as zero reference. • Turbidity value of zero calibration solution should be entered in {VALUE.Z}. • Turbidity value of span calibration solution should be entered in {VALUE.S}. • Calculates calibration factor after the inputs of zero and span values.
	ZERO		Zero correction • Uses water sample. Corrects deviation by adjusting measured value to the lab data of water sample.
	SPAN		Sensitivity correction • Uses water sample. Corrects sensitivity by adjusting measured value to the lab data of water sample.

F7-6E.ai

Figure 7.6 Concept of Calibration

Note: Either zero correction or sensitivity correction can be performed.

For instance, a sensitivity correction after a zero corrosion will move the zero point.

(1) Zero correction

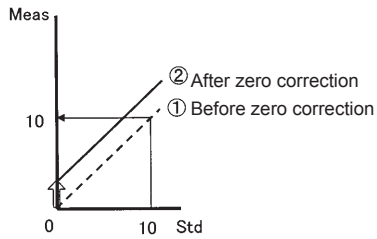

(2) Sensitivity correction

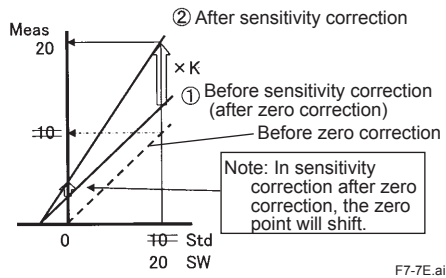

F7-7E.ai

Figure 7.7 Sensitivity correction after zero calibration

Procedures of each calibration are described below. For the turbidity standards used for calibration, see Section 1.2. If the turbidimeter is used in conjunction with an optional ultrasonic cleaning system, power to the ultrasonic transducer (TUS400G) should be removed before zero and span calibrations using turbidity standards.

Pressing the [MODE] key will abort the setting procedure.

7.6.1 Zero Calibration Using Zero Water

After washing the measurement cell, supply zero water and perform a zero calibration in calibration mode {STD.CAL} at the operation level.

- (1) Putting the converter in calibration mode (maintenance state).
 1. Press the [MODE] key on the converter. The message display should show {CALIB}.
 2. Press the [YES] key to enter calibration mode.
- (2) Draining the water sample.
 1. Close the sample water supply valve.
 2. Open the drain valve after the detector to drain the water sample.
- (3) Washing the measurement cell.
 1. Open the zero water supply valve to supply zero water to the detector.
 2. Close the drain valve after the detector. When the measurement cell is filled with the water, open the drain valve to drain.
 3. Repeat steps 1 and 2 at least three times to wash the inside of the measurement cell.
- (4) Supplying zero water.
 1. By adjusting the zero water supply valve, supply the zero water to the detector at a flow rate of 1 to 3 l/min.
 2. Check that the zero water is drained from the detector. Then, close the drain valve.
 3. To wet the zero turbidity filter, allow the zero water to run at a flow rate of 1 to 3 l/min for approximately 20 minutes. If the filter has been already wet, allow the zero water of approximately 10 liters to run.
- (5) Performing a zero calibration.
 1. After the reading has stabilized, close the zero water supply valve.
 2. The message display should show {STD.CAL}. Press the [YES] key to accept a calibration using standards.
 3. On the message display, {ZERO} will appear. Press the [YES] key to accept a zero calibration.
 4. On the message display, {VALUE} will appear, and on the data display, {0.000} should appear. Press the [ENT] key.
 5. The turbidimeter starts a calibration (self-adjustment) with the flashing entire data display. Wait for a while.
Note: Pressing the [ENT] key during the self-adjustment will abort the calibration. Do not press any keys unless you want to abort the calibration.
 6. After the self-adjustment is complete, the message display will show {CAL.END}.
- (6) To continue to perform a span calibration, press the [NO] key and proceed to step (4) in Subsection 7.6.2, "Span Calibration using the Check Block."
- (7) To end the zero calibration, open the drain valve after the detector to drain zero water.
- (8) Open the sample water supply valve to supply a water sample to the detector.
- (9) Putting the converter in measurement mode.
 1. When {CAL.END} is shown on the message display, press the [YES] key.
 2. The message display should show {HOLD}. Press the [NO] key to exit from the maintenance state (output is held) and return to measurement mode.
Note: If the analog output hold function has been set to Disabled {H.OFF} in SET HOLD mode at the setting level, a {HOLD} display in step 2 is not shown.
- (10) Zero calibration is now complete.

7.6.2 Span Calibration Using the Check Block



NOTE

Before using the check block, wash it with mild detergent and then rinse it with water. Do not wipe it dry and use it in wet condition. For cleaning procedures, refer to "How to Clean the Check Block".

A span calibration is normally performed using the supplied check block in span calibration mode {STD.CAL} at the operation level. A certain turbidity value is assigned to the check block after the TB750G turbidimeter has been calibrated with a formazin standard solution at the factory.



NOTE

The calibration should be performed using turbidity standards, which requires time-consuming procedures. As a convenient way of span calibration, a check block supplied can be used. For details of calibration using turbidity standards, see Subsection 7.6 3.



NOTE

Care must be exercised not to lose the check block supplied with the turbidimeter. The check block has a turbidity value unique to the turbidimeter of interest. Therefore, the same check block cannot be purchased again. If it is lost, contact Yokogawa.

- (1) Putting the converter in calibration mode (maintenance state).
 1. Press the [MODE] key on the converter. The message display should show {CALIB}.
 2. Press the [YES] key to enter calibration mode.
- (2) Draining the water sample.
 1. Close the sample water supply valve.
 2. Open the drain valve after the detector to drain the water sample.
- (3) Washing the measurement cell.
 1. Open the zero water supply valve to supply zero water to the detector.
 2. Close the drain valve after the detector. When the measurement cell is filled with the water, open the drain valve to drain.
 3. Repeat steps 1 and 2 at least three times to wash the inside of the measurement cell.
- (4) Installing the check block. Before installing, check that the check block is clean. If not, wash off the dirt following the cleaning procedure, "How to Clean the Check Block."
 1. Make sure that the zero water supply valve is closed and the drain valve is open.
 2. Remove the rubber cover from the top of the detector.
 3. Remove the retaining plate on the window of the top cover by loosening the 2 setscrews.

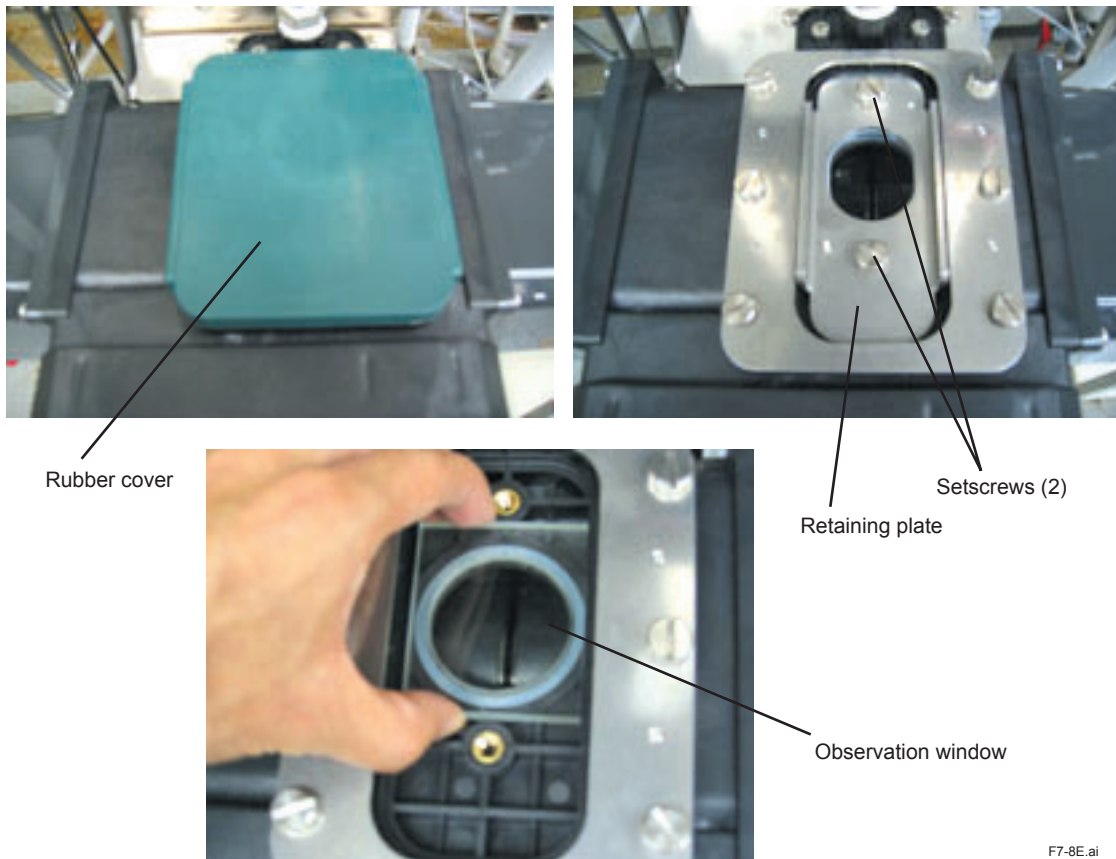

Figure 7.8 Top of the Detector

F7-8E.ai

4. Detach the observation window and replace it with the check block. Fix it with the 2 setscrews securely.

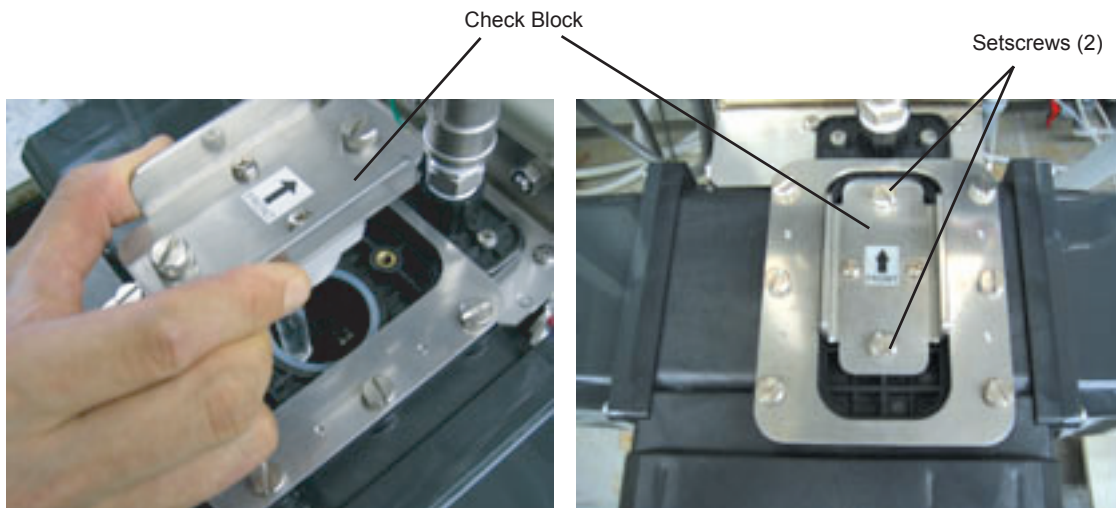

Figure 7.9 Check Block

F7-9E.ai

- (5) Introducing zero water.
 1. Open the zero water supply valve.
 2. By adjusting the zero water supply valve, supply the zero water to the detector at a flow rate of 1 to 3 l/min.
 3. Check that the zero water is drained from the detector. Close the drain valve.
 4. To wet the zero turbidity filter, allow the zero water to run at a flow rate of 1 to 3 l/min for approximately 20 minutes. If the filter has been already wet, allow the zero water of approximately 10 liters to run.
- (6) Performing a span calibration.
 1. Check that the reading stabilizes. Then, close the zero water supply valve. Check that {STD. CAL} is shown on the message display. Press the [YES] key to enter the calibration.
 2. The message display will show {ZERO}. Press the [NO] key. The display will show {SPAN} and then press the [YES] key to enter the span calibration.
 3. The message display will show {VALUE}. Check that the data display reads the same value as the one described on the check block, and press the [ENT] key.
 4. The turbidimeter starts a calibration (self-adjustment) with the flashing entire data display. Wait for a while.

Note: Pressing the [ENT] key during the self-adjustment will abort the calibration. Do not press any keys unless you want to abort the calibration.
 5. After the self-adjustment is complete, the message display will show {CAL.END}.
- (7) Removing the check block.
 1. Open the drain valve of the detector to drain zero water.
 2. Remove the check block by loosening the 2 setscrews.
 3. Replace the observation window and fix the retaining plate with the 2 setscrews securely.
 4. Replace the rubber cover to the top of the detector.
- (8) Open the sample water supply valve to supply the water sample to the detector.
- (9) Putting the converter in measurement mode.
 1. When {CAL.END} is shown on the message display, press the [YES] key.
 2. The message display should show {HOLD}. Press the [NO] key to exit from the maintenance state (output is held) and return to measurement mode.

Note: If the analog output hold function has been set to Disabled {H.OFF} in SET HOLD mode at the setting level, a {HOLD} display in step 2 is not shown.
- (10) Span calibration is now complete.

How to Clean the Check Block

Dust and dirt on the check block should be removed as follows.

Take the following steps to wash the check block with mild detergent.

1. Dissolve an adequate amount of mild detergent in tap water.
2. Soak and shake the check block in the solution to remove dirt on the surface.
3. If dirt still persists, gently rub the rod with a tissue paper in the solution to remove the dirt.
4. Thoroughly rinse off the washing solution with tap water.
5. When using the check block immediately, do not shake off the residual solution on the rod and use it in wet condition. For storage, shake off the residual solution and blot with a tissue paper. Take care not to hardily rub the rod when blotting.

**NOTE**

- Avoid rubbing hardy regardless of the material of the cloth.
- Do not use agents other than mild detergent for wash; avoid ethanol, acetone, and other solvents.
- Do not use fingers to wipe off the rod.
- Handle with care. Scratches on the rod may interfere with accurate measurement.

7.6.3 Span Calibration Using a Formazin Standard Solution

A span calibration can be performed using a formazin standard solution in span calibration mode {STD.CAL} at the operation level. For the preparation of the formazin calibration standards solution, see Section 1.3. As for the formazin calibration standard solution with a turbidity of 2 NTU or less, extreme care must be taken to prevent air bubbles from being contained when preparing and when introducing it to the measurement cell.

- (1) Selecting the standard solution in CODE 16 at the service level.
 1. Press the [*] key on the converter for at least one second to enter the setting level.
 2. Press the [NO] key repeatedly until {*SERV} appears on the message display. Press the [YES] key to enter the service level.
 3. The message display should show {*CODE}. Set the data display to "16" using the [>] and [^] keys. Then, press the [ENT] key.
 4. The message display should show {*CAL.TP}. Set the data display to "0" (standard solution) using the [>] and [^] keys. Then, press the [ENT] key.
 5. Check that the message display shows {*SERV}.
- (2) Putting the converter in calibration mode (maintenance state).
 1. Press the [MODE] key on the converter. The message display should show {CALIB}.
 2. Press the [YES] key to enter calibration mode.
- (3) Draining the water sample.
 1. Close the sample water supply valve.
 2. Open the drain valve after the detector to drain the water sample.
- (4) Washing the measurement cell.
 1. Open the zero water supply valve to supply zero water to the detector.
 2. Close the drain valve after the detector. When the measurement cell is filled with the water, open the drain valve to drain.
 3. Repeat steps 1 and 2 at least three times to wash the inside of the measurement cell.
- (5) Rinsing the measurement cell with the formazin calibration standard solution.
 1. Make sure that the zero water supply valve and the drain valve are closed.
 2. Remove the rubber cover from the top of the detector. Remove the top cover by loosening the 6 setscrews.
 3. Slowly pour the formazin calibration standard solution into the measurement cell, taking care not to allow air bubbles to enter the cell. When the measurement cell is filled to approximately 90% with the calibration standard solution, open the drain valve to drain the calibration solution.
 4. Continue to pour the calibration standard solution to rinse the measurement cell.

- (6) Supplying the formazin calibration standard solution.
1. Close the drain valve after the detector. Slowly pour the formazin calibration standard solution into the measurement cell, using a funnel or relevant equipment, taking care not to allow air bubbles to enter the cell. Care should be taken that the end of the funnel does not contact with the solution level. This is to prevent the contamination of the standard solution with dirt on the funnel.

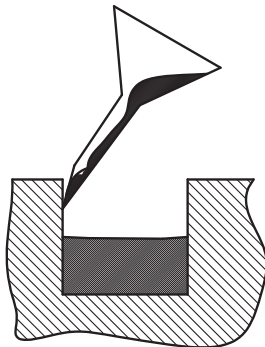

F7-10E.ai

Figure 7.10 How to Pour the Standard Solution

2. The measurement cell should be filled to 90% with the calibration standard solution. Replace the top cover, fix it securely with the 6 setscrews, and attach the rubber cover.
- (7) Performing a span calibration.
1. Wait 3 to 5 minutes until the reading has stabilized. Check that {STD.CAL} is shown on the message display. Press the [YES] key to enter the calibration using the standards.
 2. The message display should show {ZERO}. Press the [NO] key. The message display should show {SPAN}. Press the [YES] key to enter the span calibration.
 3. The message display should show {VALUE}.
 4. Set the decimal point position in the data display using the [>] key. Press the [ENT] key to accept the position.
e.g., "0.000" (when using a 2 NTU formazin calibration standard solution)
 5. Set the value on the data display to the value of the calibration standard solution using the [>] and [^] keys and press the [ENT] key.
e.g., "2.000" (when using a 2 NTU formazin calibration standard solution)
 6. The turbidimeter starts a calibration (self-adjustment) with the flashing entire data display. Wait for a while.
Note: Pressing the [ENT] key during the self-adjustment will abort the calibration. Do not press any keys unless you want to abort the calibration.
 7. After the self-adjustment is complete, the message display will show {CAL.END}.
- (8) Open the drain valve after the detector to drain the calibration standard solution.
- (9) Open the sample water supply valve to supply the water sample to the detector. It will take time for the replacement of the entire solution in the measurement cell: from the calibration standard solution to the water sample.
- (10) Putting the converter in measurement mode.
1. When {CAL.END} is shown on the message display, press the [YES] key.
 2. The message display should show {HOLD}. Press the [NO] key to exit from the maintenance state (output is held) and return to measurement mode.
Note: If the analog output hold function has been set to Disabled {*H.OFF} in SET HOLD mode at the setting level, a {HOLD} display in step 2 is not shown.
- (11) Span calibration is now complete.

7.7 2-point Calibration Using Turbidity Standard Solutions

A 2-point calibration of the TB750G is performed with turbidity standard solutions equivalent to zero water and to span water. After accepting both zero and span values, the meter calculates a calibration factor.

There are three ways to prepare calibration standard solutions for the 2-point calibration as follows.

- (1) Zero and span calibration standard solutions are prepared by the user.
- (2) A zero solution is prepared by the user and a span solution is commercially obtained.
- (3) Zero and span solutions are commercially obtained.

(1) Using user-prepared zero and span solutions

The turbidity of diluting water for calibration should be measured using a calibrated lab turbidimeter. A span solution should be prepared in accordance with the instructions in Section 1.3, "Formazin Standard Solution." If the turbidity of diluting water is high as against the measurement accuracy, add the turbidity of diluting water to the nominal turbidity of the prepared formazin standard solution.

Use diluting water as zero solution and a formazin solution as span solution for the calibration. As a zero solution, a formazin solution with a turbidity different from the span solution's may be used. To perform a calibration accurately, however, it is recommended that standard solutions with approximately zero turbidity and with span turbidity be used as zero and span solutions, respectively.

(2) Using a user-prepared zero solution and a commercially prepared span solution

A zero solution should be prepared and its turbidity should be measured using a calibrated lab turbidimeter. Use the prepared zero solution and commercially prepared span solution for the calibration. As stated above, a formazin solution with a turbidity different from the span solution's may be used as a zero solution.

(3) Using commercially prepared zero and span solutions

Supply commercially prepared zero and span solutions to perform the calibration.

The following describes how to perform a 2-point calibration.

Prepare zero and span solutions according to the above. As for the formazin calibration standard solution with a turbidity of 2 NTU or less, extreme care must be taken to prevent air bubbles from being contained when preparing and when introducing it to the measurement cell.

- (1) Putting the converter in calibration mode (maintenance state).
 1. Press the [MODE] key on the converter. The message display should show {CALIB}.
 2. Press the [YES] key to enter calibration mode.
- (2) Draining the water sample.
 1. Close the sample water supply valve.
 2. Open the drain valve after the detector to drain the water sample.

- (3) Washing the measurement cell.
 1. Open the zero water supply valve to supply zero water to the detector.
 2. Close the drain valve after the detector. When the measurement cell is filled with the water, open the drain valve to drain.
 3. Repeat steps 1 and 2 at least three times to wash the inside of the measurement cell.
- (4) Rinsing the measurement cell with the zero calibration solution.
 1. Make sure that the zero water supply valve and drain valve are closed.
 2. Remove the rubber cover from the top of the detector. Remove the top cover by loosening the 6 setscrews.
 3. Slowly pour the zero calibration solution into the measurement cell, taking care not to allow air bubbles to enter the cell. When the measurement cell is filled to approximately 90% with the solution, open the drain valve to drain the calibration solution.
 4. Continue to pour the zero calibration solution to rinse the measurement cell.
- (5) Supplying the zero calibration solution to the measurement cell.
 1. Close the drain valve after the detector. Pour the zero calibration solution into the measurement cell very slowly, using a funnel or relevant equipment, taking care not to allow air bubbles to enter the cell. Care should be taken that the end of the funnel does not contact with the solution level.

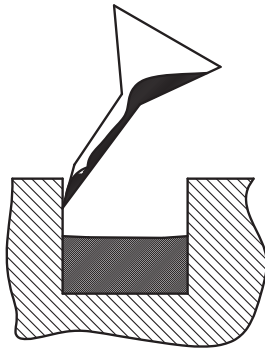

F7-11E.ai

Figure 7.11 How to Pour the Standard Solution

2. The measurement cell should be filled to 90% with the zero calibration solution. Replace the top cover, fix it securely with the 6 setscrews, and attach the rubber cover.
 - (6) Perform a zero calibration.
 1. Wait 3 to 5 minutes until the reading has stabilized. Check that {STD.CAL} is shown on the message display.
 2. Press the [NO] key. The message display should show {SMP.CAL}. Press the [YES] key.
 3. The message display should show {ZRSPN}. Press the [YES] key to select the zero calibration.
 4. The message display should show {VALUE.Z}.
 5. Set the decimal point position in the data display using the [>] key. Press the [ENT] key to accept the position.
e.g., "0.000"
 6. Set the value on the data display to the value of the zero calibration solution using the [>] and [^] keys and press the [ENT] key.
e.g., "0.020"
 7. The turbidimeter starts a calibration (self-adjustment) with the flashing entire data display. Wait for while.
- Note: Pressing the [ENT] key during the self-adjustment will abort the calibration. Do not press any keys unless you want to abort the calibration.

8. After the self-adjustment is complete, the message display will show {SPAN}.
- Note: At this stage, the zero calibration has not been yet reflected in measured values. A calibration factor will be calculated after the span calibration is completed.
- (7) Open the drain valve after the detector to drain the zero calibration solution.
- (8) Rinsing the measurement cell with the span calibration solution.
1. Make sure that the zero water supply valve and the drain valve are closed.
 2. Remove the rubber cover from the top of the detector. Remove the top cover by loosening the 6 setscrews.
 3. Slowly pour the span calibration solution into the measurement cell, taking care not to allow air bubbles to enter the cell. When the measurement cell is filled to approximately 90% with the solution, open the drain valve to drain the calibration solution.
 4. Continue to pour the span calibration solution to the measurement cell.
- (9) Supplying the span calibration solution to the measurement cell.
1. Close the drain valve after the detector. Pour the span calibration solution into the measurement cell very slowly, using a funnel or relevant equipment, taking care not to allow air bubbles to enter the cell. Care should be taken that the end of the funnel does not contact with the solution level.
 2. The measurement cell should be filled to 90% with the span calibration solution. Replace the top cover, fix it securely with the 6 setscrews, and attach the rubber cover.
- (10) Performing a span calibration.
1. Wait 3 to 5 minutes until the reading has stabilized. Check that {SPAN} is shown on the message display. Press the [YES] key to select the span calibration.
- Note: Pressing the [NO] key is invalid.
2. The message display should show {VALUE.S}
 3. Set the decimal point position in the data display using the [>] key. Press the [ENT] key to accept the position.
e.g. "00.00"
 4. Set the value on the data display to the value of the span calibration solution using the [>] and [^] keys and press the [ENT] key.
e.g., "20.00"
 5. The turbidimeter starts a calibration (self-adjustment) with the flashing entire data display. Wait for a while.
- Note: Pressing the [ENT] key during the self-adjustment will abort the calibration. Do not press any keys unless you want to abort the calibration.
6. After the self-adjustment is complete, the message display will show {CAL.END}.
- (11) Open the drain valve after the detector to drain the span calibration solution.
- (12) Open the sample water supply valve to supply the water sample to the detector. It will take time for the complete replacement of the calibration solution in the measurement cell with the water sample.
- (13) Putting the converter in measurement mode.
1. When {CAL.END} is shown on the message display, press the [YES] key.
 2. The message display should show {HOLD}. Press the [NO] key to exit from the maintenance state (output is held) and return to measurement mode.
- Note: If the analog output hold function has been set to Disabled {*H.OFF} in SET HOLD mode at the setting level, a {HOLD} display in step 2. is not shown.
- (14) Calibration is now complete.
- Note: After a 2-point calibration, a zero point correction or a sensitivity correction, the turbidity meter will not show the value indicated on the check block even if the check block is installed in zero solution in measurement mode. The value on the check block is valid only for STD.CAL.

7.8 Grab Sample Calibration

Even after the calibration using turbidity standards, the turbidity measured by the instrument may differ from the one measured manually in a lab. This is due to the difference of properties of the water sample and of turbidity measurement methods. A grab sample calibration is for correcting these differences. With the water sample running, adjust the instrument so that it reads the same value as the one measured in a lab.

This calibration should be performed when:

- the turbidity measured by the instrument has differed from the one measured manually in a lab even after the calibration using turbidity standards;
- the property of the water sample has changed with the seasons or because of other reasons.

A grab sample calibration comprises a zero shift calibration to correct the zero point and a span calibration to correct the sensitivity, and is performed in {SMP.CAL} mode at the operation level.

Procedure

- (1) Take an aliquot of the water sample and manually determine its turbidity in the lab.
- (2) Putting the converter in the maintenance state.
 1. Press the [MODE] key on the converter. The message display should show {CALIB}.
 2. Press the [YES] key to enter calibration mode.
- (3) Draining the water sample.
 1. Close the sample water supply valve.
 2. Open the drain valve after the detector to drain the water sample.
- (4) Washing the measurement cell.
 1. Open the zero water supply valve to supply zero water to the detector.
 2. Close the drain valve after the detector. When the measurement cell is filled with the water, open the drain valve to drain.
 3. Repeat steps 1 and 2 at least three times to wash the inside of the measurement cell.
- (5) Supplying the water sample.
 1. Close the zero water supply valve.
 2. Open the sample water supply valve to supply the water sample.
 3. Visually check that the water sample is drained from the drain of the detector. Then, close the drain valve.
- (6) Performing a grab sample calibration.
 1. Allow the water sample to flow at least 5 minutes. Make sure that the reading has stabilized and the message display shows {STD.CAL}.
 2. Press the [NO] key. The message display should show {SMP.CAL}. Press the [YES] key to enter the grab sample calibration.
 3. The message display will show {ZERO}.
 - To perform a zero calibration, press the [YES] key to enter the zero shift calibration (zero point correction).
 - To perform a span calibration (sensitivity correction), press the [NO] key. The message display should show {SPAN}. Then, press the [YES] key to enter the span calibration.
 4. The message display should show {VALUE}.
 5. Set the decimal point position in the data display using the [>] key. Press the [ENT] key to accept the position.
 - e.g., "0.000" (when the lab turbidity is 0.85 NTU)

6. Set the value on the data display to the lab value using the [>] and [^] keys and press the [ENT] key.
e.g., "0.850" (when the lab turbidity is 0.85 NTU)
 7. The turbidimeter starts a calibration (self-adjustment) with the flashing entire data display. Wait for a while.
Note: Pressing the [ENT] key during the self-adjustment will abort the calibration. Do not press any keys unless you want to abort the calibration.
 8. After the self-adjustment is complete, the message display will show {CAL.END}.
- (7) Putting the converter in measurement mode.
1. When {CAL.END} is shown on the message display, press the [YES] key.
 2. The message display should show {HOLD}. Press the [NO] key to exit from the maintenance state (output is held) and return to measurement mode.
Note: If the analog output hold function has been set to Disabled {*H.OFF} in SET HOLD mode at the setting level, a {HOLD} display in step 2 is not shown.
- (8) Calibration is now complete.

7.9 Checking and Replacing Desiccants

If the humidity in the detector (the light source unit and the receiver) is high when a water sample with low temperature runs into the measurement cell, condensation may form on the window glass. To prevent this, the light source unit and the receiver should be kept dry. Remove the desiccants from the light source unit and from the receiver, and check for softness with the hand. Desiccants that have become soft thoroughly in gel form should be replaced.

- (1) Putting the converter in the maintenance state.
 1. Press the [MODE] key on the converter. Check the {CALIB} is shown on the message display.
 2. Press the [NO] key. The message display should show {HOLD}. Press the [YES] key to enter analog output hold selection mode.
 3. Check that {HOLD} is flashing on the message display. Press the [YES] key to put the converter in the maintenance state (analog output signal is held). The HOLD indicator turns on.

Note: If the analog output hold function has been set to Disabled {*H.OFF} in SET HOLD mode at the setting level, steps 2 and 3 cannot be done. If analog output should be held during maintenance, select Enabled {H.ON}. (The factory default is Enabled {*H.ON}.)
- (2) Remove the covers of the light source unit and the receiver on both left and right sides of the detector by loosening the 4 setscrews.
- (3) Remove the desiccants and check for softness with the hand. Desiccants soft textured in gel form should be replaced.
- (4) Install the desiccants which printed side is putting inner side in place. Attach and securely fix the covers of the light source unit and the receiver on both left and right sides of the detector with the 4 setscrews.
- (5) Putting the converter in measurement mode.
 1. Press the [MODE] key on the converter. Check that the message display shows {CALB}.
 2. Press the [NO] key repeatedly until {HOLD} appears on the message display. Press the [YES] key to enter analog output hold selection mode.
 3. Check that {HOLD} is flashing on the message display. Press the [NO] key to exit from the maintenance state (analog hold is held) and return to measurement mode. The HOLD indicator turns off.
- (6) Desiccant check is now complete.

After checking or replacing desiccants, allow the instrument to warm up for at least one hour before measurement so that desiccants can remove moisture inside the detector.

7.10 Checking the Operation of Each Input/Output

Upon startup or when a failure occurs, the operation and status of each input/output (analog output, contact output, and contact input) can be checked in analog output test mode (CODE 71), contact output test mode (CODE 72) and contact input test mode (CODE 73) at the service level on the converter.

7.10.1 Checking the Operation of the Analog Output

Output currents of analog output 1 and 2 terminals can be checked in analog output test mode, CODE 71 at the service level on the converter, using a tester or relevant equipment.

- (1) Putting the converter in analog output test mode (CODE 71).
 1. Press the [*] key on the converter for at least one second to enter the setting level.
 2. Press the [NO] key repeatedly until {*SERV} appears on the message display. Press the [YES] key to enter the service level.
 3. The message display should show {*CODE}. Set the data display to "71" using the [>] and [^] keys. Then, press the [ENT] key.
- (2) Checking the operation of the analog output (for details, see Figure 6.35).
 1. Check that the message display shows either {*A01.T} (analog output 1) or {*A02.T} (analog output 2).
 2. Press the [NO] key to toggle the options and when the desired option is shown, press the [YES] key.
 3. The current value displayed on the data display will be output to the analog output terminal. For example, "02.4" on the data display means that a 2.4 mA current is output to analog output terminal. Connect a tester or relevant equipment to the analog output terminal, and check the output with it. The tester must read the same value as the one on display.
 4. Each press of the [ENT] key will change the current value. Check the reading each time with the tester.
 5. The message display will show {*END} when the test is completed.
 6. To continue the test to check the other analog output, press the [NO] key and repeat steps 1 through 5. To exit from the test mode, press the [YES] key.
- (3) Putting the converter in measurement mode.
 1. Check that the message display shows {*SERV}. Press the [MODE] key.
 2. The message display should show {HOLD}. Press the [NO] key to exit from the maintenance state (output is held) and return to measurement mode.

Note: If the analog output hold function has been set to Disabled {*H.OFF} in SET HOLD mode at the setting level, a {HOLD} display in step 2 is not shown.
- (4) Test is now complete.

If the test finds a defect, the converter needs adjustment or remedy. Contact our Service.

7.10.2 Checking the Operation of the Contact Output

The status of the contact output can be checked in contact output test mode, CODE 71 at the service level on the converter, using a tester or relevant equipment.

- (1) Putting the converter in analog output test mode (CODE 72).
 1. Press the [*] key on the converter for at least one second to enter the setting level.
 2. Press the [NO] key repeatedly until {*SERV} appears on the message display. Press the [YES] key to enter the service level.
 3. The message display should show {*CODE}. Set the data display to "72" using the [>] and [^] keys. Then, press the [ENT] key.
- (2) Checking the operation of the contact output (for details, see Figure 6.36).
 1. Check that the message display shows {*DO.T1} (Contact output test display 1).
 2. Set each digit on the data display to "0" (Non-action) or "1" (Action) using [>] and [^] keys. Each digit of the data display corresponds the contact output as follows.

Data display:	X.X.X.X.X
Digit No.	1.2.3.4.5.6.
Digit description:	1: S1 contact output
	2: S2 contact output
	3: FAIL contact output
	4: Range A contact output (RANGE-COM)
	5: Range B contact output (RANGE-COM)
	6: Range C contact output (RANGE-COM)
 3. When each digit of the data display is set to 0 (Non-action) or 1 (Action), the corresponding contact is put in the status accordingly. Connect a tester or relevant equipment to each contact output terminal and check the operation of each contact. The contact must operate in accordance with the test settings.
 4. Pressing the [ENT] key will move the display to {*DO.T2} (Contact output test display 2). This is a contact output test for internal circuitry and should be skipped. Press the [ENT] key to exit from the contact output test mode.
- (3) Putting the converter in measurement mode.
 1. Check that the message display shows {*SERV}. Press the [MODE] key.
 2. The message display should show {HOLD}. Press the [NO] key to exit from the maintenance state (output is held) and return to measurement mode.

Note: If the analog output hold function has been set to Disabled {*H.OFF} in SET HOLD mode at the setting level, a {HOLD} display in step 2 is not shown.
- (4) Test is now complete.

If the test finds a defect, the converter need replacement, for example, of contact relays. Contact our Service.

7.10.3 Checking the Operation of the Contact Input

The status of each contact input can be checked in contact input test mode, CODE 73 at the service level on the converter.

- (1) Putting the converter in analog output test mode (CODE 73).
 1. Press the [*] key on the converter for at least one second to enter the setting level.
 2. Press the [NO] key repeatedly until {*SERV} appears on the message display. Press the [YES] key to enter the service level.
 3. The message display should show {*CODE}. Set the data display to "73" using the [>] and [^] keys. Then, press the [ENT] key.
- (2) Checking the operation of the contact input (for details, see Figure 6.37).
 1. Check that the message display shows {*DI.T} (Contact input test display).
 2. The data display shows the current status of each contact input by 0 (Non-action) or 1 (Action). Each digit of the data display corresponds the contact input as follows

Data display:	X.X
Digit No.	1.2
Digit description:	1: Contact input 1 (IN1-COM)
	2: Contact input 2 (IN2-COM)
 3. Put the contact input terminal in non-action state (open) or action state (closed). The corresponding digit of the contact input must show the status accordingly.
 4. Upon completion of check, press the [ENT] key to exit from the contact input test mode.
- (3) Putting the converter in measurement mode.
 1. Check that the message display shows {*SERV}. Press the [MODE] key.
 2. The message display should show {HOLD}. Press the [NO] key to exit from the maintenance state (output is held) and return to measurement mode.

Note: If the analog output hold function has been set to Disabled {*H.OFF} in SET HOLD mode at the setting level, a {HOLD} display in step 2 is not shown.
- (4) Test is now complete.

If the test finds a defect, the converter need replacement, for example, of contact relays. Contact our Service.

7.11 Replacing the Zero Turbidity Filter Element

The zero turbidity filter element should be replaced at regular intervals.

- (1) Make sure that the zero water supply valve and the zero water drain valve after the zero turbidity filter are closed.
- (2) Close the tap water valve before the zero turbidity filter to stop supplying tap water.
- (3) Turn and remove the filter case. (Care should be taken. The internal water runs over.)
- (4) If the inside of the case is dirty, clean it with a brush or relevant tool.
- (5) Replace the filter element with a new one.
- (6) Reassemble the filter. Be sure to install the O-ring in place, otherwise water may leak.
- (7) Open the tap water valve before the zero turbidity filter to supply tap water and open the zero water drain valve after the filter to supply zero water. Check for leak.
- (8) Loosen the air vent valve on top of the zero turbidity filter until the tap water begins to leak out. After the air vent, tighten the valve securely.
- (9) Allow the water to flow for at least 20 minutes to wet the filter element.
- (10) Close the zero water drain valve after the zero turbidity filter.
- (11) Replacement is now complete.

Note: If the zero turbidity filter is not to be used for a prolonged time, remove, dry and store the filter element in a dry place.



NOTE

Do not mix up two different sizes (1 μm and 0.2 μm) of the zero turbidity filter element if installing two zero turbidity filters.

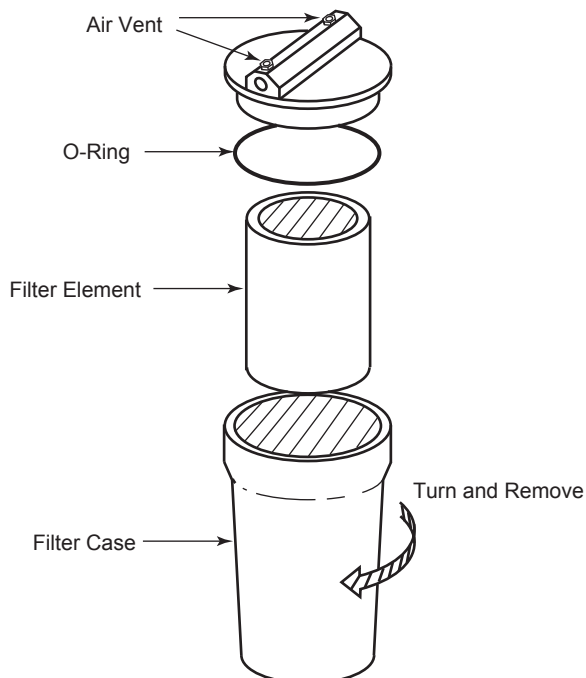

F7-12E.ai

Figure 7.12 Replacement of the Zero Turbidity Filter Element

7.12 Fuse Replacement

For preventive maintenance, it is recommended that the fuse be replaced at an interval of one year.

- (1) Remove power from the TB750G turbidimeter.
- (2) Remove the front cover of the detector by loosening the 4 setscrews.
- (3) Take the fuse holder out. (See Figure 7.13)
- (4) Replace the fuse with a new one.
- (5) Replace the front cover to the detector.
- (6) Turn on the power of the TB750G turbidimeter.
- (7) Allow the turbidimeter to warm up for at least 30 minutes before starting measurement.
- (8) Fuse replacement is now complete.

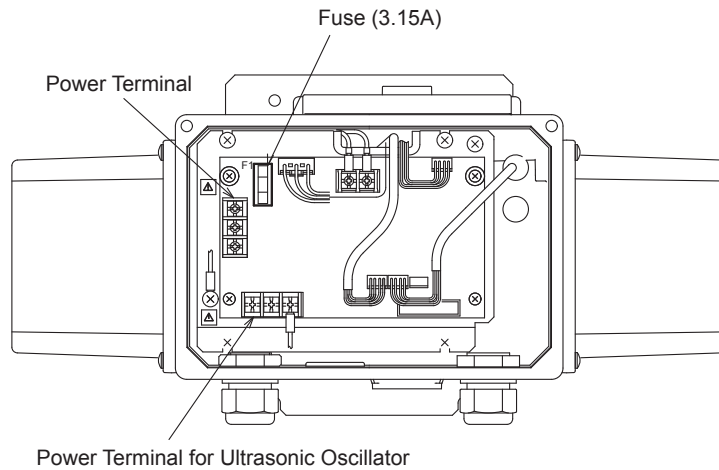

F7-13E.ai

Figure 7.13 Fuse Replacement



CAUTION

Before opening the front cover of the detector, turn off power to the TB750G turbidimeter. Make sure that the turbidimeter is not powered before work. Do not touch terminals while the turbidimeter is being powered.

7.13 Pipe Cleaning

Remove the pipes between the detector and the head tank, and clean them.

- (1) Putting the converter in the maintenance state.
 1. Press the [MODE] key on the converter repeatedly. Check the {CALIB} is shown on the message display.
 2. Press the [NO] key. The message display should show {HOLD}. Press the [YES] key to enter analog output hold selection mode.
 3. Check that {HOLD} is flashing on the message display. Press the [YES] key to put the converter in the maintenance state (analog output signal is held). The HOLD indicator turns on.
Note: If the analog output hold function has been set to Disabled {H.OFF} in SET HOLD mode at the setting level, steps 2 and 3 cannot be done. If analog output should be held during maintenance, select Enabled {H.ON}. (The factory default is Enabled {H.ON}.)
- (2) Close the sample water supply valve.
- (3) Close the sample water valve and open the drain valve of the head tank to drain the water from the head tank.
- (4) Check that the water in the head tank has been drained off. Remove the pipes between the detector and the head tank. Clean the inside using a long brush or relevant tool, and wash away with tap water. If pipes are heavily stained and dirt cannot be removed, replace them with new ones.
- (5) Reinstall the pipes between the detector and the head tank.
- (6) Open the sample water valve to supply a water sample to the head tank. Close the drain valve of the head tank.
- (7) Open the sample water supply valve to supply the water sample to the detector.
- (8) Putting the converter in measurement mode.
 1. Press the [MODE] key on the converter. Check that the message display shows {CALB}.
 2. Press the [NO] key repeatedly until {HOLD} appears on the message display. Press the [YES] key to enter analog output hold selection mode.
 3. Check that {HOLD} is flashing on the message display. Press the [NO] key to exit from the maintenance state (analog hold is held) and return to measurement mode. The HOLD indicator turns off.
- (9) Pipe cleaning is now complete.

7.14 Cleaning the Front Covers of the Detector and the Converter

The front covers of the detector and the converter are made of polycarbonate resin. The transparent window on the converter front cover is also made of weatherproof polycarbonate resin. Adhesion of oil or organic solvents may cause cloudiness or cracking. Dirt on the covers or window should be removed using a tissue paper or soft cloth soaked in water. For stubborn stains, use a tissue paper or soft cloth soaked in mild detergent to remove them. Then, wipe them off using a tissue paper or soft cloth soaked in water.



NOTE

Do not use organic solvents (ethanol, acetone, etc.) for cleaning the front covers of the converter (including the window) and the detector. Organic solvents may cause cloudiness or cracking.

7.15 Spare Parts

Spare parts are supplied with the instrument. Table 7.2 shows recommended replacement intervals. The intervals are determined in light of preventive maintenance, so accidental failures are excluded from considerations. The recommended intervals are subject to change because of field performances and others.

Table 7.2 Spare Part List

Item	Part Number	Recommended Interval*1
Lamp assembly	K9657PW	Yearly*2
Filter, 1 μm	K9008ZD	Yearly
Filter, 0.2 μm	K9726EH	Yearly
Fuse, 3.15 A, 1 piece	A1113EF	Yearly
Desiccant, 4 pcs*3	K9657RJ	Yearly

*1: Recommended intervals vary depending on the application.

*2: If an expired lamp life error (E203) or lamp intensity failure (E204) occurs, determine the cause and if necessary, replace the lamp with a new one.

*3: Use within a year after purchasing.

8. TROUBLESHOOTING

When a failure occurs in the converter or the detector, self-diagnostics detects it, the FAIL lamp turns on, and the FAIL indicator turns on and the error number appears on the display, signaling that the problem is occurring. From the error number, details of the error can be known. Inspect the instrument according to the instructions in Section 8.1.

Improper readings may occur that cannot be checked by self-diagnostics. If such a failure occurs but the FAIL lamp does not turn on, inspect the instrument according to the instructions in Section 8.2.

For inspections, a multimeter or tester that can measure DC/AC voltage, DC current, and resistance, are required. After the inspection, if part replacement or repair is needed, or if the cause of the problem cannot be located, contact Yokogawa.

8.1 When a Failure Occurs and the FAIL Lamp Turns On

When the FAIL lamp turns on during measurement, check the error number on the display and take the procedure corresponding to the number for troubleshooting. The error numbers and their descriptions are listed in Table 8.4.

Depending on the level of importance, the error codes are categorized into 3 parts: errors E1xx, E2xx, and E3xx. As for some errors in errors E2xx and E3xx, whether error detection is enabled or disabled can be selected (CODES 66 and 67).

The errors are divided into three levels – Level 1 (severe), Level 2 (moderate), and Level 3 (minor) – depending on the degree to which the error affects the performance of the instrument. While errors E1xx are preset to Level 1 and errors E3xx to Level 3 at the factory and both are not user configurable, errors E2xx are user selectable to either Level 1 or Level 2 (CODE 66).

Table 8.1 Error Level

Error Code	Error Detection (CODE No)	Error Level Selection		
		Level 1	Level 2	Level 3
E102 to E104	Enabled, fixed	√ (fixed)		
E201, E202	Enabled/disabled, selectable (CODE 66)	√ (default)	√	
E203 to E205	Enabled/disabled, selectable (CODE 66)	√	√ (default)	
E301 to E307	Enabled/disabled, selectable (CODE 67)			√ (fixed)
E321, E351, E352	Enabled, fixed			√ (fixed)

Table 8.2 Actions When an Error Occurs

Error Level	Output Hold*1	FAIL Lamp	FAIL Contact	FAIL Indicator	High/Low Alarm*2	If occurs during calibration, calibration will
Level 1	On	On	Deenergized	Lit	Disabled	Abort*3
Level 2	Off	Off	Energized	Lit	Enabled	Continue
Level 3	Off	Off	Energized	Flashing	Enabled	Continue

*1: When hold function is set to "1: Enabled" in CODE 35.

*2: When contact output function is set to "1: Alarm" in CODE 40 or 41, and alarm setting function is set to "1: Enabled" in CODE 51.

*3: If an error occurs during self-adjustment in calibration mode, the display will move to {CAL.END}.

(1) E102 (EEPROM failure), E103 (RAM failure), and E104 (AD converter failure)

Check	Possible Cause and Action
Turn power off and then back on.	If error occurs again, failure of memory or other function may have occurred. ==> Request repair service.

(2) E201 (Input voltage failure)

Check	Possible Cause and Action
Check if detection element input voltage is outside the range of -0.15 to 1.2 V. Check input voltage (IN1, IN2) in CODE 02.	Failure of detection element, preamplifier, amplifier, AD converter, etc. may have occurred. ==> Request repair service.

(3) E202 (Detection element failure)

Possible Cause and Action
Failure of detection element, preamplifier, amplifier, AD converter, etc, may have occurred. ==> Request repair service.

(4) E203 (Lamp life expired)

Check	Possible Cause and Action
Remove front cover of detector and measure lamp voltage at terminal TM3. The voltage must be 3.5 ± 0.1 VDC.	Lamp life has almost expired (disconnected). ==> Replacement is recommended. If lamp voltage is outside the range, board failure may have occurred. ==> Request repair service.

(5) **E204 (Lamp intensity failure)**

Check	Possible Cause and Action
Remove front cover of detector and measure lamp voltage at terminal TM3. The voltage must be 3.5 ± 0.1 VDC.	Lamp intensity has reduced to the degree that measurement error occurs. ==> Perform zero and span calibrations. Prepare the spare. If lamp voltage is outside the range, board failure may have occurred. ==> Request repair service.

(6) **E205 (Calibration failure)**

Check	Possible Cause and Action
Check error code E3xx.	Any of errors E301 to E307, or E321 is occurring. ==> Take action in accordance with instructions in the relevant error code.

(7) **E301 (Turbidity zero calibration coefficient A failure)**

Check	Possible Cause and Action
Measure turbidity of zero water at a lab.	If turbidity is high, zero filter element has failed. ==> Replace the zero filter element. Perform a zero calibration.
If turbidity is normal, check measurement cell window for dirt.	Dirt or air bubbles on window may interfere with accurate measurement. ==> Wash window with detergent. Perform a zero calibration.

(8) **E302 (Turbidity slope SL failure)**

Check	Possible Cause and Action
Measure turbidity of zero water at a lab.	If turbidity is high, zero filter element has failed. ==> Replace the zero filter element. Perform a zero calibration.
If turbidity is normal, check measurement cell window for dirt.	Dirt or air bubbles on window may interfere with accurate measurement. ==> Wash window with detergent. Perform a zero calibration.
Remove front cover of detector. Measure lamp voltage at terminal TM3. The voltage must be 3.5 ± 0.1 VDC.	If lamp voltage is within the range, lamp intensity may have reduced. ==> Replace with spare. If lamp voltage is outside the range, board failure may have occurred. ==> Request repair service.

(9) E303 (Turbidity check block failure)

Check	Possible Cause and Action
Check if value on check block agrees with value in CODE 17.	Improper setting of the value on check block causes calibration error. ==> Enter the correct value.
Check the check block for scratch or dirt.	Scratches interfere with correct calibration. ==> Contact Yokogawa Dirt interferes with correct calibration. ==> Wash off with water or using mild detergent.
Check cell window for dirt.	Dirt or air bubbles on the window causes measurement error. ==> Wash window with detergent. Recalibrate.
Remove front cover of detector. Measure lamp voltage at terminal TM3. The voltage must be 3.5 ±0.1 VDC.	If lamp voltage is within the range, lamp intensity may have reduced. ==> Replace with spare. If lamp voltage is outside the range, board failure may have occurred. ==> Request repair service.

(10) E304 (Turbidity zero correction factor B failure)

Check	Possible Cause and Action
Check if calibration has been performed within the range where zero shift can be done.	Calibration can be performed within the turbidity range of -9 to 9 NTU. ==> Perform calibration within this range.

(11) E305 (Turbidity sensitivity correction factor K failure)

Check	Possible Cause and Action
Check if span calibration has been performed within the range where span calibration can be done.	Calibration can be performed within the correction factor range of 0.25 to 4. ==> Perform calibration within this range.

(12) E306 (Turbidity reference sensitivity SO failure)

Check	Possible Cause and Action
Measure turbidity of calibration solution at a lab.	If turbidity is not the certified turbidity, calibration error has occurred. ==> Prepare fresh calibration solution. Perform a span calibration.
If turbidity is normal, check measurement cell window for dirt.	Dirt or air bubbles on window may interfere with accurate measurement. ==> Wash window with detergent. Perform a zero calibration.
Remove front cover of detector. Measure lamp voltage at terminal TM3. The voltage must be 3.5 ±0.1 VDC.	If lamp voltage is within the range, lamp intensity may have reduced. ==> Replace with spare. If lamp voltage is outside the range, board failure may have occurred. ==> Request repair service.

(13) E307 (Turbidity response time failure)

Check	Possible Cause and Action
Supply calibration solution to measurement cell in detector. Check for reading change.	If calibration is started while reading is changing sharply, the error may occur. ==> After reading has stabilized, perform calibration.



NOTE

After the lamp has been replaced, allow the instrument to undergo a shakedown period of at least one hour and then perform zero and span calibrations.

8.2 When a Failure Occurs but the FAIL Lamp Does Not Turn On

When a reading failure occurs that self-diagnostics cannot detect, inspect the instrument while referring to Table 8.3.

Table 8.3 Troubleshooting

Problem	Possible Cause	Check/Corrective Action
Large fluctuation of turbidity reading	Property of turbidity matter in a water sample.	Increase time constant.
Rapid change in turbidity reading	Air bubbles.	Close the valve at detector outlet to reduce the flow rate. Increase time constant. Set the spike detection function to Enabled in CODE 08.
Drift of turbidity reading	Stained measurement cell. Air bubbles on glass window. Condensation on glass window.	Wash glass window and measurement cell. Ultrasonic cleaning is also effective measure. Air bubble significantly affects measurement when sample water turbidity is 2 NTU or less. To prevent air bubbles from forming on glass, clean glass surface. Reduce flow rate by closing valve at detector outlet. Wet desiccant may cause condensation. Check desiccant, and replace it.

8.3 Error Code List

Table 8.4 Error Code List (1/2)

No.	Error	Occurrence	Problem	Return
E102	EEPROM write failure	All modes	Data is written in EEPROM and verified, and write failure occurs 3 consecutive times.	When power is turned off and then on again, and problem is eliminated. (Without [YES]/[NO] key press.)
E103	RAM failure	When power is turned on.	RAM area failure (3 consecutive times).	
E104	AD converter failure	All modes	AD converter failure (3 consecutive times).	
E201	Input voltage failure	All modes	Either IN1 or IN2 input voltage is outside the range of -0.15 to 1.2 V (fixed), including abnormal value 0x7FFF or 8000, for 5 consecutive seconds.	When problem is eliminated for 5 consecutive seconds. When [YES]/[NO] key is pressed, error code display disappears, at the same time during failure, error is once removed.
E202	Detection element failure	All modes	Either IN1 or IN2 input voltage is less than specified voltage for 5 consecutive seconds.	
E203	Lamp life expired	Zero calibration coefficient A rewriting timing. (excluding when E301 or E311 occurs.)*1	During zero calibration self-adjustment, input voltage IN1 is less than specified voltage for 5 consecutive seconds. (Not detected when E301 is occurring.) Rewriting of zero calibration coefficient A is performed.	
E204	Lamp intensity failure			
E205	Calibration failure	E301 to E307, E311 to E317, E321 during PC communication occurrence timing	Any of E301 to E307, E321 during PC communication is occurring.	

Table 8.4 Error Code List (2/2)

No.	Error	Occurrence	Problem	Return
E301	Turbidity zero calibration coefficient A failure	During zero calibration (zero water).	Turbidity zero calibration coefficient A newly determined after zero calibration (zero water or lamp OFF) is outside of the range of 0 to 5, or each coordinate value of newly determined linearized table is outside of the range of -99999 to 999999.	When problem is eliminated. When [YES]/[NO] key is pressed, error code display disappears, at the same time during failure, error is once removed.
E302	Turbidity slope SL failure	During span calibration (standard solution)	Turbidity slope value SL newly determined after span calibration (standard solution) is outside of the range of 25 to 200%, or each coordinate value of newly determined linearized table is outside of the range of -99999 to 999999.	
E303	Turbidity check block failure	During span calibration (check block)	Turbidity slope value SL newly determined after span calibration (check block) is outside of the range of 50 to 150%, or each coordinate value of newly determined linearized table is outside of the range of -99999 to 999999.	
E304	Turbidity zero correction factor B failure	During zero shift calibration	Turbidity zero correction factor B newly determined after zero shift calibration is outside of the range of -9 to 9.	
E305	Turbidity sensitivity correction factor K failure	During span calibration (sensitivity correction)	Turbidity sensitivity correction factor K newly determined after span calibration (sensitivity correction) is outside of the range of 0.25 to 4.	
E306	Turbidity reference sensitivity SO failure	During turbidity reference sensitivity calibration	Turbidity reference sensitivity SO newly set after span calibration (check block) is outside of the tolerance of 0.0001 to 2000, or each coordinate value of newly determined linearized table is outside of the range of -99999 to 999999.	
E307	Turbidity response time failure	All calibrations	Turbidity self-adjustment is not complete before self-adjustment time has elapsed.	
E321	Communication error	During communication with PC	Any communication error during communication with PC.	When problem is eliminated in the next communication (only one time is OK). When [YES]/[NO] key is pressed, error code display disappears, at the same time during failure, error is once removed. (excluding RS signal during communication with calibration/cleaning controller.)
E351	Analog output range setting failure	During parameter setting in RANGE mode or CODE 30.	Either of: (1) Zero point \geq span point, or (2) Span point - zero point $<$ 20% of span point or 0.20, whichever is greater (for turbidity) or (span point - zero point $<$ 5.00 (for color). When automatic range is selected in CODE 30, also possible: (3) At each span point, Range A \geq Range B, or (4) at each span point, Range B \geq Range C	When [YES]/[NO] key is pressed, error code display disappears and error is removed.
E352	Parameter setting failure	During parameter setting	Value outside the setting range is set in setting other than AO range setting.	

Worksheet for Operation Parameter Setting

Serial No.

Service Level (1)

Code/Setting Parameter	Display	Default Value *
CODE02 Input voltage display		(See page 6-11)			
Transmitted light detection element input display	* IN1				
Scattered light detection element input display	* IN2				
End	* END				
CODE08 Spike detection parameter setting		(See page 6-12)			
Spike detection function enabled or disabled	* SPIKE	0:Disabled			
Limit value	* LIMIT	999.999(NTU)			
Hold time	* HLD-T	030(s)			
Sampling time	* SMP-T	030(s)			
CODE11 Zero calibration factor display		(See page 6-15)			
Zero calibration factor display	* CAL.A	Depends on MS Code **			
CODE12 Slope display		(See page 6-15)			
Slope display	* SL	100.0(%)			
CODE13 Zero correction factor setting		(See page 6-15)			
Zero correction factor setting	* CAL.B	00.000(NTU)			
CODE14 Sensitivity correction factor setting		(See page 6-16)			
Sensitivity correction factor setting	* CAL.K	1.0000			
CODE16 Standard solution/check block selection		(See page 6-16)			
Standard solution or check block	* CAL.TP	1:Check Block			
CODE17 Check block turbidity setting		(See page 6-16)			
Check block turbidity	* PLATE	90.00(NTU)			
CODE30 Analog output range switching parameter setting		(See page 6-18)			
Range switching output selection	* RNGPR	0:Fixed			
Range switching function selection	* RSET	1:Automatic			
Range A setting	* RSET.A				
Zero point for range A	* ZERO	0000.00(NTU)			
Span point for range A	* SPAN	0010.00(NTU)			
Range B setting	* RSET.B				
Zero point for range B	* ZERO	0000.00(NTU)			
Span point for range B	* SPAN	0100.00(NTU)			
Range C setting	* RSET.C				
Zero point for range C	* ZERO	0000.00(NTU)			
Span point for range C	* SPAN	1000.00(NTU)			
Automatic range switching point	* AUTOR	080(%)			

* Default value is a value at the time of initializing in CODE79 (Initialization) of service level.

** This value differs from the value at the time of factory shipment.

Service Level (2)

Code/Setting Parameter	Display	Default Value *	.	.	.
CODE33 Analog output 2 range selection		(See page 6-19)			
Range selection for output 2	*mA2	0:4.0-20.0mA			
Fixed value for hold	*H.mA2	22.0(mA)			
Fixed value for hold during failure	*FH.mA2	22.0(mA)			
CODE35 Hold during failure parameter setting		(See page 6-20)			
Hold function enabled or disabled					
Last measured value, or	*FHOLD	1: Enabled			
Limit value	*FH.LST	*FH.FIX:Fixed			
Fixed value for output 1	/*FH.FIX	value			
Fixed value for output 2	*FH.mA1	22.0(mA)			
	*FH.mA2	22.0(mA)			
CODE37 Time constant setting		(See page 6-20)			
Time constant in measurement	*TC	020(s)			
Time constant in maintenance	*TC-M	006(s)			
CODE40 Contact output S1 function selection		(See page 6-21)			
Function of contact output S1	*S1	1: Alarm			
CODE41 Contact output S2 function selection		(See page 6-21)			
Function of contact output S2	*S2	3: Maintenance			
CODE44 Delay time/hysteresis setting		(See page 6-22)			
Delay time	*D.TIME	000(s)			
Hysteresis	*HYST	002(%)			
CODE50 Auto return function selection		(See page 6-22)			
Auto return function enabled or disabled	*RET	0: Disabled			
CODE51 Alarm setting function selection		(See page 6-23)			
Alarm setting function enabled or disabled	*MODE	0: Disabled			
CODE52 Password setting		(See page 6-23)			
Password	*PASS	0.0.0			
CODE54 Negative nondisplay/nonoutput selection		(See page 6-24)			
Negative nondisplay/nonoutput enabled or disabled	*MINUS	0.0: Disabled. Disabled			
CODE61 Turbidity unit selection		(See page 6-24)			
Turbidity unit	*UNIT	0: NTU			
CODE64 Software version display		(See page 6-24)			
Software version display	*VER	1.00			
CODE66 Error "E2xx" error level selection		(See page 6-25)			
Error levels of errors "E201" to "E206"	*201-6	1.1.2.2.2.2			
CODE67 Error "E3xx" error detection selection		(See page 6-25)			
Error detection for "E301" to "E306"	*301-6	1.1.1.1.1.1			
Error detection for "E307"	*307	1			
Error detection for "E311" to "E316"	*311-6	1.1.1.1.1.1			
Error detection for "E317"	*317	1			

Service Level (3)

Code/Setting Parameter	Display	Default Value *	.	.	.
CODE71 Analog output test		(See page 6-26)			
Start test for output 1	<i>*AO1.T</i>				
Test current flowing					
End	<i>*END</i>				
Start test for output 2	<i>*AO2.T</i>				
Test current flowing					
End	<i>*END</i>				
CODE72 Contact output test		(See page 6-27)			
Test 1	<i>*DO.T1</i>	Last measured value held			
Test 2	<i>*DO.T2</i>	Last measured value held			
CODE73 Contact input test		(See page 6-27)			
Test	<i>*DI.T</i>				
CODE79 Initialization		(See page 6-28)			
Start	<i>*LOAD</i>				
Default loading	<i>*WAIT</i>				

Setting Level

Code/Setting Parameter		Display	Default Value *	.	.	.
SETPOINTS	Alarm setting	*SETP	(See page 6-7)			
	High alarm setpoint	*S.TB-H	2200.0 (NTU)			
	Low alarm setpoint	*S.TB-L	-010.0 (NTU)			
RANGE	Analog output range setting	*RANGE	(See page 6-7)			
	Fixed range for output 1, or fixed range for output 2	*FIXR.1 or *FIXR.2				
	Zero point	*ZERO	0000.00 (NTU)			
	Span point	*SPAN	0100.00 (NTU)(*FIXR.1) 1000.00 (NTU)(*FIXR.2)			
	Local range selection	*LOCAL				
	Local range for output 1, or local range for output 2	*LCL.1 or *LCL.2	0 :Range A			
SET HOLD	Hold parameter setting	*HOLD	(See page 6-9)			
	Hold function enabled, or hold function disabled	*H.ON or *H.OFF	*H.ON :Enabled			
	Last measured value, or fixed value	*H.LST or *H.FIX	*H.LST :Last measured value			
	Fixed value for output 1	*H.mA1	22.0 (mA)			
	Fixed value for output 2	*H.mA2	22.0 (mA)			

Customer Maintenance Parts List

Model TB750G
Right Angle Scattered Light Turbidimeter

CONVERTER

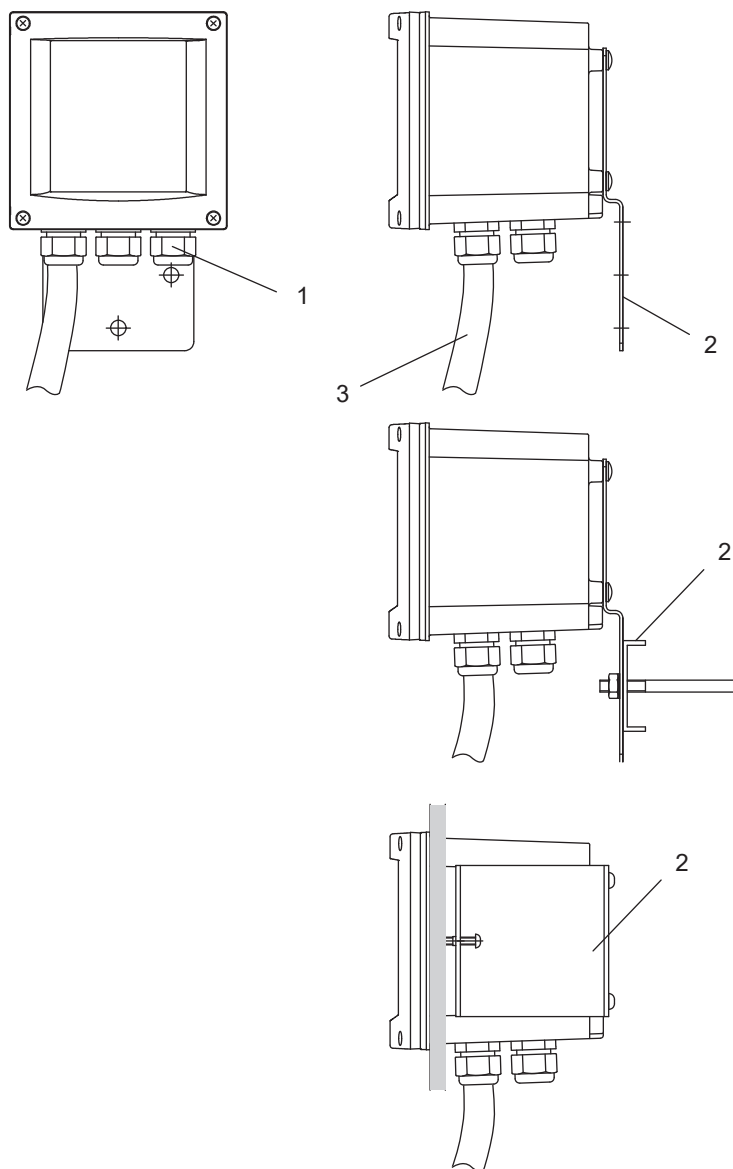

Item	Part No.	Qty	Description
1	L9811FV	1	Cable Gland
2	-	1	Mounting Hardware (Option Code, in case of /R) (Option Code, in case of /U) (Option Code, in case of /PM)
3	-	1	Cable
	K9657EA		1 m (for TB750G-NTU-....-1)
	K9657EB		2 m (for TB750G-NTU-....-2)
	K9657EC		3 m (for TB750G-NTU-....-3)

DETECTOR

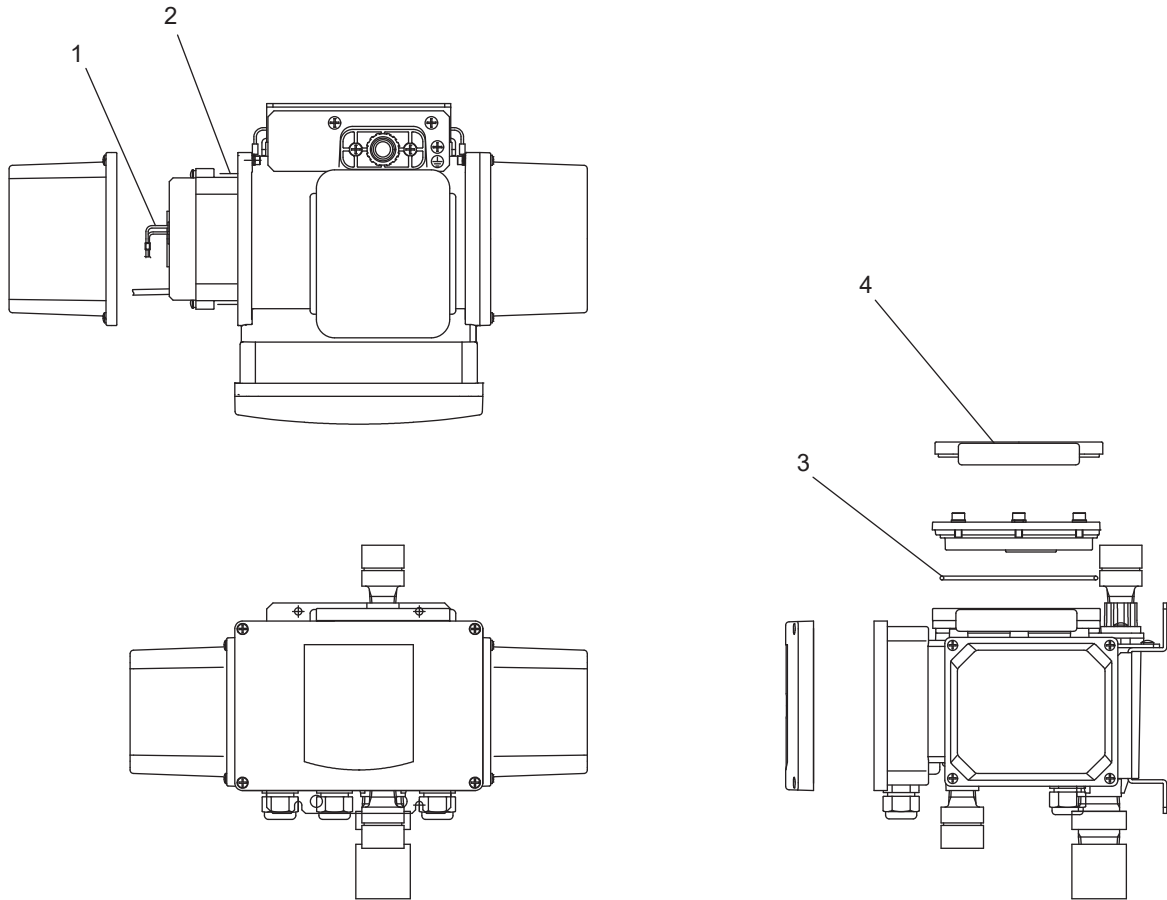

Item	Part No.	Qty	Description
1	K9657PW	1	Lamp Assembly
2	K9657RJ	1	Desiccant
3	K9657NS	1	Gasket
4	K9657NW	1	Cover

K9411UA ZERO TURBIDITY FILTER ASSEMBLY (1 micron filter)
K9726EF ZERO TURBIDITY FILTER ASSEMBLY (0.2 micron filter)

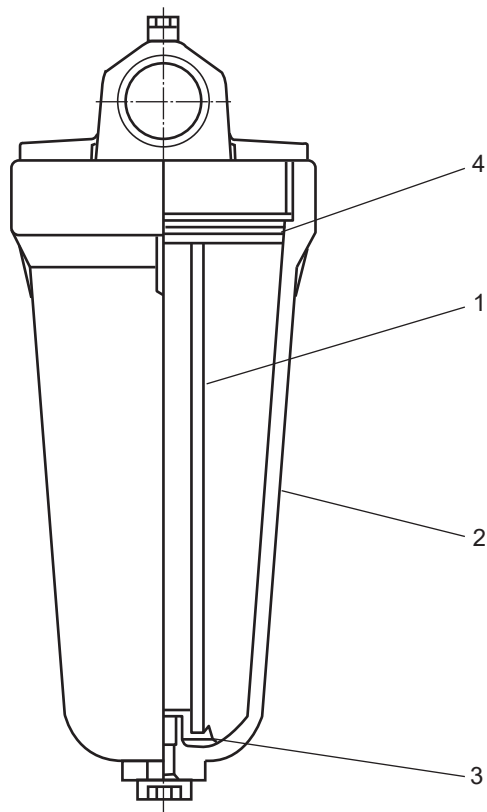

Item	Part No.	Qty	Description
1	-	1	Filter Element (1 micron) (0.2 micron)
2	K9411UB	1	Case
3	K9008ZE	1	Plate
4	K9411UD	1	O-Ring

Revision Information

- Title: Model TB750G Right Angle Scattered Light Turbidimeter
- Manual No.: IM 12E01A06-01E

Edition	Date	Remark (s)
5th	Jan. 2019	CMPL (Customer Maintenance Parts List) was revised.
4th	Feb. 2018	Error code E101 was entirely deleted. (p. 2-3, 8-1, 8-2, 8-6)
3rd	Mar. 2015	<ul style="list-style-type: none"> • p. 2-4 Some revision of Section 2.1, "Standard Specifications" (3) Output range switching: The unit of the "number of the contact" is eliminated. • p. 2-6, Some revision of Section 2.1, "Standard Specifications" : Finish of converter housing will be changed from polyester resin power coating to baked polyurethane resin coating. • p. 2-7, Addition of RCM (C-Tick) marking and KC marking. Some revision of Section 2.4, "Model and Codes" : Baked epoxy resin coating is also available (optional code /X1). • p. 2-8, • p. 2-11, • p. 3-4, Some revision of Consumables (note added). Some revision of 2.7 Connection Diagram. • p. 3-23, Some revision of Section 3.1.3, "Installation Dimensions" : Spell miss correction for Converter of Panel Mounting (Option Code "/PM"). Some revision of 3.2.12 Wiring to the Ultrasonic Transducer (When Option Code "/US" is specified). • p. 7-21, • p. 7-28, • p. 8-2, • p. 8-3, • p. 8-6, Some revision of Section 7.9, "Checking and Replacing Desiccants". Some revision of Spare Parts (note added). Some revision of E201 to E203 description. Some revision of E204 description. Some revision of Section 8.3, "Error Code List".
2nd	Mar. 2006	Addition of 2-point calibration and panel mounting (/PM) by a change of specifications.
1st	Aug. 2005	Newly published

