

**BLA Supplement: Clinical Review**

Application Type	Efficacy Supplement
STN	125566/51
CBER Received Date	February 25, 2016
PDUFA Goal Date	December 25, 2016
Division / Office	DCEPT/OTAT
Priority Review	No
Reviewer Name(s)	Megha Kaushal
Review Completion Date / Stamped Date	12/19/2016
Supervisory Concurrence	
Applicant	Baxalta US Inc.
Established Name	Antihemophilic Factor (Recombinant), PEGylated
Trade Name	Adynovate
Pharmacologic Class	N/A
Formulation(s), including Adjuvants, etc	Lyophilized powder in single-use vials
Dosage Form(s) and Route(s) of Administration	250, 500, 1000, or 2000 international units (IU) for intravenous use
Dosing Regimen	On-demand treatment and control of bleeding episodes & perioperative management: Estimated Increment of factor VIII (IU/dL or % of normal) = [Total Dose (IU)/body weight (kg)] x 2 (IU/dL per IU/kg); Dose (IU) = Body Weight (kg) x Desired factor VIII Rise (IU/dL or % of Normal) x 0.5 (IU/kg per IU/dL); Routine prophylaxis: Administer (b) (4) IU per kg body weight 2 times a week (40-60 IU per kg body weight in patients <12 years of age).
Indication(s) and Intended Population(s)	On-demand treatment and control of bleeding episodes; Perioperative management; Routine prophylaxis to reduce the frequency of bleeding episodes for adults and children
Orphan Designated (Yes/No)	No

**TABLE OF CONTENTS**

<b>GLOSSARY .....</b>	<b>1</b>
<b>1. EXECUTIVE SUMMARY .....</b>	<b>1</b>
1.1 Demographic Information: Subgroup Demographics and Analysis Summary .....	2
<b>2. CLINICAL AND REGULATORY BACKGROUND .....</b>	<b>4</b>
2.1 Disease or Health-Related Condition(s) Studied .....	4
2.2 Currently Available, Pharmacologically Unrelated Treatment(s)/Intervention(s) for the Proposed Indication(s) .....	4
2.3 Safety and Efficacy of Pharmacologically Related Products .....	4
2.4 Previous Human Experience with the Product (Including Foreign Experience) .....	5
2.5 Summary of Pre- and Post-submission Regulatory Activity Related to the Submission .....	5
2.6 Other Relevant Background Information .....	6
<b>3. SUBMISSION QUALITY AND GOOD CLINICAL PRACTICES .....</b>	<b>6</b>
3.1 Submission Quality and Completeness .....	6
3.2 Compliance With Good Clinical Practices And Submission Integrity .....	6
3.3 Financial Disclosures .....	6
<b>4. SIGNIFICANT EFFICACY/SAFETY ISSUES RELATED TO OTHER REVIEW DISCIPLINES .....</b>	<b>7</b>
4.1 Chemistry, Manufacturing, and Controls .....	7
4.2 Assay Validation .....	7
4.3 Nonclinical Pharmacology/Toxicology .....	7
4.4 Clinical Pharmacology .....	7
4.4.1 Mechanism of Action .....	8
4.4.2 Human Pharmacodynamics (PD) .....	8
4.4.3 Human Pharmacokinetics (PK) .....	8
4.5 Statistical .....	8
4.6 Pharmacovigilance .....	8
<b>5. SOURCES OF CLINICAL DATA AND OTHER INFORMATION CONSIDERED IN THE REVIEW .....</b>	<b>8</b>
5.1 Review Strategy .....	8
5.2 BLA/IND Documents That Serve as the Basis for the Clinical Review .....	9
5.3 Table of Studies/Clinical Trials .....	9
5.4 Consultations .....	9
5.4.1 Advisory Committee Meeting (if applicable) .....	10
5.4.2 External Consults/Collaborations .....	10
5.5 Literature Reviewed (if applicable) .....	10
<b>6. DISCUSSION OF INDIVIDUAL STUDIES/CLINICAL TRIALS .....</b>	<b>10</b>
<b>6.1 Trial #1 .....</b>	<b>10</b>
6.1.1 Objectives (Primary, Secondary, etc) .....	11
6.1.2 Design Overview .....	11
6.1.3 Population .....	12
6.1.4 Study Treatments or Agents Mandated by the Protocol .....	12
6.1.5 Directions for Use .....	12
6.1.6 Sites and Centers .....	13
6.1.7 Surveillance/Monitoring .....	13
6.1.8 Endpoints and Criteria for Study Success .....	13
6.1.9 Statistical Considerations & Statistical Analysis Plan .....	13
6.1.10 Study Population and Disposition .....	14

---

6.1.11 Efficacy Analyses .....	16
6.1.12 Safety Analyses.....	19
6.1.13 Study Summary and Conclusions .....	21
<b>6.2 Trial #2.....</b>	<b>21</b>
6.2.1 Objectives (Primary, Secondary, etc).....	22
6.2.2 Design Overview .....	22
6.2.3 Population.....	23
6.2.4 Study Treatments or Agents Mandated by the Protocol .....	23
6.2.5 Directions for Use .....	24
6.2.6 Sites and Centers.....	24
6.2.7 Surveillance/Monitoring .....	24
6.2.8 Endpoints and Criteria for Study Success.....	24
6.2.9 Statistical Considerations & Statistical Analysis Plan .....	25
6.2.10 Study Population and Disposition.....	25
6.2.11 Efficacy Analyses .....	27
6.2.12 Safety Analyses.....	30
<b>7. INTEGRATED OVERVIEW OF EFFICACY.....</b>	<b>31</b>
<b>7.1 Indication #1 .....</b>	<b>31</b>
7.1.1 Methods of Integration.....	31
7.1.2 Demographics and Baseline Characteristics.....	31
7.1.3 Subject Disposition .....	31
7.1.4 Analysis of Primary Endpoint(s) .....	31
7.1.5 Analysis of Secondary Endpoint(s) .....	32
7.1.6 Other Endpoints.....	32
7.1.7 Subpopulations.....	32
7.1.8 Persistence of Efficacy .....	32
7.1.9 Product-Product Interactions.....	32
7.1.10 Additional Efficacy Issues/Analyses .....	32
7.1.11 Efficacy Conclusions .....	32
<b>7.2 Indication #2 .....</b>	<b>32</b>
7.2.1 Methods of Integration.....	32
7.2.2 Demographics and Baseline Characteristics.....	32
7.2.3 Subject Disposition .....	32
7.2.4 Analysis of Primary Endpoint(s) .....	32
7.2.5 Analysis of Secondary Endpoint(s) .....	32
7.2.6 Other Endpoints.....	32
7.2.7 Subpopulations.....	32
7.2.8 Persistence of Efficacy .....	33
7.2.9 Product-Product Interactions.....	33
7.2.10 Additional Efficacy Issues/Analyses .....	33
7.2.11 Efficacy Conclusions .....	33
<b>8. INTEGRATED OVERVIEW OF SAFETY.....</b>	<b>33</b>
<b>8.1 Safety Assessment Methods .....</b>	<b>33</b>
<b>8.2 Safety Database .....</b>	<b>33</b>
8.2.1 Studies/Clinical Trials Used to Evaluate Safety .....	33
8.2.2 Overall Exposure, Demographics of Pooled Safety Populations .....	33
8.2.3 Categorization of Adverse Events .....	33
<b>8.3 Caveats Introduced by Pooling of Data Across Studies/Clinical Trials .....</b>	<b>33</b>
<b>8.4 Safety Results .....</b>	<b>33</b>
8.4.1 Deaths .....	33
8.4.2 Nonfatal Serious Adverse Events.....	33
8.4.3 Study Dropouts/Discontinuations .....	34
8.4.4 Common Adverse Events.....	34

---

---

8.4.5 Clinical Test Results .....	34
8.4.6 Systemic Adverse Events .....	34
8.4.7 Local Reactogenicity .....	34
8.4.8 Adverse Events of Special Interest .....	34
<b>8.5 Additional Safety Evaluations .....</b>	<b>34</b>
8.5.1 Dose Dependency for Adverse Events .....	34
8.5.2 Time Dependency for Adverse Events .....	34
8.5.3 Product-Demographic Interactions .....	34
8.5.4 Product-Disease Interactions .....	34
8.5.5 Product-Product Interactions .....	34
8.5.6 Human Carcinogenicity .....	34
8.5.7 Overdose, Drug Abuse Potential, Withdrawal, and Rebound .....	34
8.5.8 Immunogenicity (Safety) .....	34
<b>8.6 Safety Conclusions .....</b>	<b>35</b>
<b>9. ADDITIONAL CLINICAL ISSUES .....</b>	<b>35</b>
<b>9.1 Special Populations .....</b>	<b>35</b>
9.1.1 Human Reproduction and Pregnancy Data .....	35
9.1.2 Use During Lactation .....	35
9.1.3 Pediatric Use and PREA Considerations .....	35
9.1.4 Immunocompromised Patients .....	35
9.1.5 Geriatric Use .....	35
<b>9.2 Aspect(s) of the Clinical Evaluation Not Previously Covered .....</b>	<b>35</b>
<b>10. CONCLUSIONS .....</b>	<b>35</b>
<b>11. RISK-BENEFIT CONSIDERATIONS AND RECOMMENDATIONS .....</b>	<b>36</b>
11.1 Risk-Benefit Considerations .....	36
11.2 Risk-Benefit Summary and Assessment .....	38
11.3 Discussion of Regulatory Options .....	38
11.4 Recommendations on Regulatory Actions .....	38
11.5 Labeling Review and Recommendations .....	38
11.6 Recommendations on Postmarketing Actions .....	38
<b>GHEA SCORING .....</b>	<b>40</b>
<b>TABLE OF TABLES</b>	
Table 1: Demographics for Pediatric Study .....	3
Table 2: BIMO Inspection Sites .....	6
Table 3: List of Clinical Studies .....	9
Table 4: Study Procedures and Assessments .....	12
Table 5: Efficacy Rating Scale for Treatment of Bleeding Episodes .....	13
Table 6: Demographics .....	15
Table 7: ABR for the Pediatric Cohort .....	16
Table 8: Bleeding Episodes in Pediatric Cohort .....	17
Table 9: Demographics in Surgery Study .....	26
Table 10: Efficacy Score for Surgery .....	28
Table 11: Risk Benefit Table .....	37
<b>TABLE OF FIGURES</b>	
Figure 1: Treatment Schema .....	11
Figure 2: Subject Disposition .....	14
Figure 3: Dosing for Surgery .....	24
Figure 4: Subject Disposition .....	27

## GLOSSARY

ABR	Annualized Bleeding Rate
ADR	Adverse Drug Reaction
AE	Adverse Event
BIMO	Bioresearch Monitoring
BLA	Biologics License Application
BU	Bethesda Unit
CHO	Chinese Hamster Ovary
CMC	Chemistry, manufacturing, and controls
CI	Confidence Interval
eCTD	Electronic Common Technical Document
ED	Exposure Days
FAS	Full Analysis Set
GCP	Good Clinical Practices
GHEA	Global Hemostatic Efficacy Assessment
ICF	Informed Consent Form
IQR	Interquartile Range
IU	International Unit
PK	Pharmacokinetic
PMC	Postmarketing commitment
PMR	Postmarketing requirement
PREA	Pediatric Research Equity Act
PTP	Previously Treated Patient
PUP	Previously Untreated Patient
PVP	Pharmacovigilance Plan
rFVIII	Recombinant Factor VIII
SAE	Serious Adverse Event

### 1. Executive Summary

ADYNOVATE or BAX 855 (Antihemophilic Factor (Recombinant), PEGylated; rFVIII, PEGylated) is a lyophilized protein manufactured in Chinese Hamster Ovary (CHO) cells. The fusion protein consists of a full length form of recombinant antihemophilic factor (b) (4) to the marketed Antihemophilic Factor (Recombinant) product, ADVATE) covalently conjugated to a polyethylene glycol (PEG) reagent. The product consists of a mixture of rFVIII molecules with varying degrees of PEGylation (varying ratios in the number of molecules of PEG moiety conjugated covalently to each rFVIII moiety) with the mean ratio of (b) (4). The PEG enables an increase of the plasma half-life through the reduction of receptor-mediated clearance of the factor VIII molecule. As a result, ADYNOVATE is longer-acting and was developed for intravenous replacement therapy or prophylaxis on a less frequent basis than standard regimens in adult and adolescent patients with hemophilia A. The elimination half-life of ADYNOVATE is 14.3 hours compared to an average half-life of 8-12 hours in non-fusion protein plasma-derived or recombinant FVIII products.

ADYNOVATE is currently approved for adolescent and adult patients (12 years or older) with hemophilia A for on-demand treatment and control of bleeding episodes and routine prophylaxis to reduce the frequency of bleeding episodes. This submission proposes to expand the current indications to a) on-demand treatment and control of bleeding and routine prophylaxis in children (<12 years of age) and b) for perioperative management in children and adults. The basis to support licensure for the proposed indications for ADYNOVATE are as follows: a) data from a phase 3 prospective uncontrolled

multicenter pediatric study to evaluate the PK, efficacy, safety and immunogenicity of ADYNOVATE in 66 pediatric subjects (<12 years of age) to support routine prophylaxis (Study # 261202) and b) data from a phase 3 multicenter, open-label study of the efficacy and safety of ADYNOVATE in previously treated patients (PTPs) with severe hemophilia A undergoing surgical or other invasive procedures to support perioperative management (Study # 261204).

The pediatric study had two age-dependent cohorts: subjects below 6 years (n=32) and those 6 to 12 years of age (n=34). Subjects received twice-weekly prophylactic treatment with  $50 \pm 10$  IU/kg of ADYNOVATE over a period of 6 months or at least 50 exposure days (EDs), whichever occurred last. A subset of subjects (12 evaluable) within each age cohort underwent a PK evaluation prior to the start of prophylactic treatment. The primary objective was to assess the incidence of FVIII inhibitory antibodies ( $\geq 0.6$  Bethesda units [BU] using the (b) (4) Bethesda assay). No subject developed inhibitory antibodies to FVIII. The adverse events (AE) profile is consistent with that previously observed in adults and adolescents. The total median annualized bleeding rate (ABR) was 2 with an Interquartile Range (IQR) of [0, 3.9] with twice weekly dosing of  $50 \pm 10$  IU/kg of ADYNOVATE.

Fifteen surgeries were performed in 15 subjects in the interim analysis of the surgical study. Eleven surgeries were major and 4 were minor. The dose of ADYNOVATE to be administered depended on the type of the surgery performed and the intensity of the hemostatic challenge. Perioperative hemostatic efficacy was rated as excellent (blood loss less than or equal to that expected for the same type of procedure performed in a non-hemophilic patient, and required blood components for transfusions less than or similar to that expected in non-hemophilic population) for all 15 procedures. The intraoperative efficacy was rated as "excellent" (blood loss was less than or equal to that expected for the type of procedure performed in a non-hemophilic patient) for all 15 procedures, and postoperative efficacy (on postoperative Day 1, i.e., the day following the day of surgery) was rated as "excellent" for all 11 major surgeries, and 2 of 3 minor surgeries; efficacy in one minor surgery was rated as "good." Postoperative blood loss was observed in 5 major surgeries. Although 3 subjects had an overall perioperative blood loss in the range of 1210 mL to 1430 mL, none of them exceeded the maximum predicted perioperative blood loss of 1500 mL for major surgeries. No deaths and no related serious adverse events occurred. ADYNOVATE was shown to be safe and well tolerated and demonstrated hemostatic efficacy in both major and minor surgeries, although there was a limited amount of subjects in this study.

### **1.1 Demographic Information: Subgroup Demographics and Analysis Summary**

All subjects were male. The median age was 6 years of age in the pediatric study.

Table 1: Demographics for Pediatric and Surgery Study

Baseline Demographics  
(Study 261202: BAX 855 Safety Analysis Set)

	Statistic	Age < 6 (N = 32)	Age 6 to <12 (N = 34)	Total (N = 66)
Age (Years)	n	32	34	66
	Mean (SD)	3.7 (1.17)	8.1 (1.92)	6.0 (2.70)
	Median	4.0	8.0	6.0
	IQR (Q1, Q3)	2.00 (3.00, 5.00)	3.00 (6.00, 9.00)	4.00 (4.00, 8.00)
	Minimum, Maximum	1, 5	6, 11	1, 11
Sex				
Male	n (%)	32 (100.0)	33 (97.1)	65 (98.5)
Female	n (%)	0 (0.0)	1 (2.9)	1 (1.5)
Race				
Asian	n (%)	10 (31.3)	7 (20.6)	17 (25.8)
Japanese	n (%)	1 (3.1)	0 (0.0)	1 (1.5)
Chinese	n (%)	2 (6.3)	2 (5.9)	4 (6.1)
Indian	n (%)	2 (6.3)	0 (0.0)	2 (3.0)
Other	n (%)	5 (15.6)	5 (14.7)	10 (15.2)
Black Or African American	n (%)	2 (6.3)	2 (5.9)	4 (6.1)
White	n (%)	18 (56.3)	25 (73.5)	43 (65.2)
Other	n (%)	1 (3.1)	0 (0.0)	1 (1.5)
Other	n (%)	1 (3.1)	0 (0.0)	1 (1.5)
Multiple	n (%)	1 (3.1)	0 (0.0)	1 (1.5)

Source: BLA 125566/51 CSR 261202 Table 4 page 164/1240

	Statistic	Age < 6 (N = 32)	Age 6 to <12 (N = 34)	Total (N = 66)
Age (Years)	n	32	34	66
	Mean (SD)	3.7 (1.17)	8.1 (1.92)	6.0 (2.70)
	Median	4.0	8.0	6.0
	IQR (Q1, Q3)	2.00 (3.00, 5.00)	3.00 (6.00, 9.00)	4.00 (4.00, 8.00)
	Minimum, Maximum	1, 5	6, 11	1, 11
Sex				
Male	n (%)	32 (100.0)	33 (97.1)	65 (98.5)
Female	n (%)	0 (0.0)	1 (2.9)	1 (1.5)
Race				
Asian	n (%)	10 (31.3)	7 (20.6)	17 (25.8)
Japanese	n (%)	1 (3.1)	0 (0.0)	1 (1.5)
Chinese	n (%)	2 (6.3)	2 (5.9)	4 (6.1)
Indian	n (%)	2 (6.3)	0 (0.0)	2 (3.0)
Other	n (%)	5 (15.6)	5 (14.7)	10 (15.2)
Black Or African American	n (%)	2 (6.3)	2 (5.9)	4 (6.1)
White	n (%)	18 (56.3)	25 (73.5)	43 (65.2)
Other	n (%)	1 (3.1)	0 (0.0)	1 (1.5)
Other	n (%)	1 (3.1)	0 (0.0)	1 (1.5)
Multiple	n (%)	1 (3.1)	0 (0.0)	1 (1.5)

Source: BLA 125566/51 CSR 261202 page 164/1240

The limited sample size in Blacks and Hispanics makes it challenging to reach conclusions about the efficacy of ADYNOVATE in these races. Since the predilection for clinical bleeding is primarily dependent on the degree of factor VIII deficiency, race-related differences in efficacy of ADYNOVATE are expected to be minimal. Therefore, it

is reasonable to extrapolate the efficacy data from Whites and Asians to the other ethnic groups.

## 2. Clinical and Regulatory Background

Adynovate was licensed in 2015 for the treatment and control of bleeding episodes and routine prophylaxis in adolescents and adults. Please refer to Section 2.2 for a detailed list of FDA-approved products available for the treatment of Hemophilia A. These products have been approved in adults and children with Hemophilia A for the control and prevention of bleeding episodes, perioperative management of bleeding and routine prophylaxis to reduce the frequency of bleeding episodes. The development of activity-neutralizing antibodies (inhibitor) to a FVIII product is the main safety concern across this class of products. Previously untreated patients (PUPs) are at higher risk of developing inhibitors.

### 2.1 Disease or Health-Related Condition(s) Studied

Hemophilia A (HA) is a rare hereditary blood disorder caused by deficiency or dysfunction of Factor VIII (FVIII) resulting in bleeding. The hemophilia A gene is located on the X chromosome with an X-linked recessive inheritance pattern and spontaneous gene mutation in 30% cases, affecting 1 in 10,000 male births, with approximately 20,000 affected males in the United States. The relationship of bleeding severity correlates with clotting factor level. Patients with <0.01 IU/ mL or <1% of functional FVIII are categorized as severe with spontaneous bleeding into joints or muscles. Moderate severity and mild severity have clotting factor levels of 1-5% and 5 to <40%, respectively. To prevent joint destruction, the standard of care for children with severe HA is primary prophylaxis with infusions of FVIII. These regular infusions are initiated at the time of the first bleeding episode in a joint or earlier aiming to prevent joint damage. However, inhibitory antibodies to infused FVIII products develop in a substantial percentage of patients treated with either plasma-derived or recombinant FVIII products, making usual treatment with FVIII complicated. Prophylaxis has been shown to prevent complications later in life and to decrease the incidence of inhibitor formation.

### 2.2 Currently Available, Pharmacologically Unrelated Treatment(s)/Intervention(s) for the Proposed Indication(s)

Treatments for hemophilia A require replacement with Factor VIII. Factor VIII treatments include human plasma-derived and recombinant Factor VIII preparations which are the mainstay of therapy. FDA-approved recombinant Factor VIII products include Helixate (CSL Behring distributed form of Kogenate FS), Kogenate FS (Bayer (b) (4) ADVATE, Recombinate, Refacto and Xyntha. There are also other approved plasma-derived Factor VIII products including: Alphanate, Humate-P and Hemofil M.

### 2.3 Safety and Efficacy of Pharmacologically Related Products

ADYNOVATE is a fusion protein that consists of a full length form of recombinant antihemophilic factor (b) (4) to the marketed recombinant Antihemophilic Factor product (ADVATE), covalently conjugated to a polyethylene glycol (PEG) reagent. ADVATE was FDA approved in 2003. Safety concerns as stated in the prescribing information for ADVATE include hypersensitivity and Factor VIII inhibitors. ADVATE is indicated for the control and prevention of bleeding episodes, perioperative management and routine prophylaxis to prevent and reduce the frequency of bleeding episodes.



## 2.4 Previous Human Experience with the Product (Including Foreign Experience)

Human subjects were exposed for the first time to ADYNOVATE under IND 15299 and the original BLA 125566/0.

## 2.5 Summary of Pre- and Post-submission Regulatory Activity Related to the Submission

The evidence for safety and effectiveness for this product was collected under IND 15299. Multiple meetings were held with the FDA throughout the development process. Key Meetings included:

- A pre-IND meeting (CRMTS#6990) on May 14, 2009
- A pre-IND meeting (CRMTS#8603) was held on September 19, 2012, to discuss a proposed protocol that included a comparative study of at least two prophylaxis doses (Protocol 261303) and the sponsor's future plans for pediatric and surgical studies. The clinical development plan included a completed Phase 1 study (Protocol 261101), a Phase 2/3 study in PTPs  $\geq 12$  years, with > 150 EDs (Protocol 261201), a pediatric study in PTPs < 12 years of age (Protocol 261202), a surgery study in at least 5 subjects with at least 10 major surgeries (Protocol 261204), a study in PUPs (Protocol 261203) and a Continuation Study to obtain at least 100 EDs in at least 200 subjects was planned (Protocol 261302). The FDA found the clinical development program to be reasonable.
- On October 8, 2013, a written response to a meeting request (CRMTS#9063) was provided. Key agreements regarding the clinical issues included agreements that:
  - 1) No additional clinical analyses of the data obtained from the biochemical analyses [that] support comparability of ADVATE Bulk Drug Substance (BDS) manufactured at the (b) (4) Neuchatel manufacturing sites would be required.
  - 2) Cross-reference of the ADVATE BLA to support the ADYNOVATE BLA filing was acceptable.
  - 3) Four dosage strengths (250, 1000, 2000 IU/vial) may be licensed since the majority of the clinical data was obtained using the 500 and 1000 IU/vial, provided CMC specifications were met.
- On March 25, 2014 a pre-BLA meeting (CRMTS#9324) was held to discuss CMC, pre-clinical and clinical issues. Key agreements regarding the content of the BLA submission were reached regarding the following clinical issues: the statistical analysis plan, the completed studies (Protocol 261201 and 261101) that were necessary to support the BLA, the studies to be included in the Integrated Summary of Efficacy (ISE) and Integrated Summary of Safety (ISS) and the proposed language to the dosing and labeling section with regard to targeting trough levels and limiting dose. The sponsor was notified that they were required to submit:
  - 1) a pediatric assessment with data to support the safety and efficacy in pediatric subjects 12 to < 18 years,
  - 2) safety and efficacy data from at least 10 subjects undergoing 10 major surgical procedures, to support a labeled claim of perioperative management, and
  - 3) a planned action to address safety concerns.

An initial pediatric study plan (iPSP) was submitted on December 11, 2013. FDA provided additional comments; following which a revised iPSP and plans to defer studies

in subjects less than 12 years of age was submitted on March 10, 2014. Following review of this submission, FDA agreed to the revised iPSP and notified the sponsor that a pediatric assessment to support the efficacy and safety of this product in pediatric subjects 12 to < 18 years would be required in the BLA submission.

**2.6 Other Relevant Background Information**

N/A

**3. SUBMISSION QUALITY AND GOOD CLINICAL PRACTICES**

**3.1 Submission Quality and Completeness**

The submission was sufficiently organized to allow a complete clinical review without unreasonable difficulty. The submission consisted of five modules in the Common Technical Document Structure.

**3.2 Compliance With Good Clinical Practices And Submission Integrity**

CBER Bioresearch Monitoring issued inspection assignments for two foreign and one domestic clinical investigator study sites participating in these trials. Fifty-two (52) study sites participated in this study; 39 study sites enrolled subjects. The inspection report is in **Table 2**, below.

Table 2: BIMO Inspection Sites

Protocol	Site #	Location	Form FDA 483 Issued	Final Classification
261202	132	Cincinnati, Ohio	No	NAI
261202	511	Lviv, Ukraine	No	NAI
261204	322	Varna, Bulgaria	No	NAI

NAI: No Action Indicated

Please refer to BIMO review memo for full details.

**3.3 Financial Disclosures**

Covered clinical study (name and/or number): 261202, 261204, and 261302		
Was a list of clinical investigators provided:	Yes <input checked="" type="checkbox"/>	No <input type="checkbox"/> (Request list from applicant)
Total number of investigators identified: <u>52</u>		
Number of investigators who are sponsor employees (including both full-time and part-time employees): <u>0</u>		
Number of investigators with disclosable financial interests/arrangements (Form FDA 3455): <u>6</u>		
If there are investigators with disclosable financial interests/arrangements, identify the number of investigators with interests/arrangements in each category (as defined in 21		

CFR 54.2(a), (b), (c) and (f):		
Compensation to the investigator for conducting the study where the value could be influenced by the outcome of the study: _____		
Significant payments of other sorts: <u>5</u>		
Proprietary interest in the product tested held by investigator: _____		
Significant equity interest held by investigator in sponsor of covered study: <u>1</u>		
Is an attachment provided with details of the disclosable financial interests/arrangements:	Yes <input checked="" type="checkbox"/>	No <input type="checkbox"/> (Request details from applicant)
Is a description of the steps taken to minimize potential bias provided:	Yes <input type="checkbox"/>	No <input type="checkbox"/> (Request information from applicant)
Number of investigators with certification of due diligence (Form FDA 3454, box 3) <u>0</u>		
Is an attachment provided with the reason:	Yes <input type="checkbox"/>	No <input type="checkbox"/> (Request explanation from applicant)

#### 4. SIGNIFICANT EFFICACY/SAFETY ISSUES RELATED TO OTHER REVIEW DISCIPLINES

##### 4.1 Chemistry, Manufacturing, and Controls

ADYNOVATE (Antihemophilic Factor, Recombinant, PEGylated) is an extended half-life (T 1/2) recombinant human coagulation factor VIII (Antihemophilic Factor Recombinant; rFVIII) modified with polyethylene glycol (PEG) and expressed in Chinese Hamster Ovary (CHO) cells. The mean number of PEG moieties per rFVIII molecule is <sup>(b) (4)</sup> ADYNOVATE is manufactured using Baxter's Antihemophilic Factor (Recombinant) which is also the active substance in Baxter's licensed product ADVATE. ADYNOVATE is manufactured by covalently binding a branched PEG reagent with a molecular weight of 20 kDa to ADVATE. No human or animal materials are employed during the manufacturing process of ADYNOVATE.

No new CMC data was submitted with this supplement.

Please refer to the original BLA including the CMC Review Memo for further details.

##### 4.2 Assay Validation

Please refer to the CMC review memo from the original BLA for complete details.

##### 4.3 Nonclinical Pharmacology/Toxicology

No new Pharmacology/Toxicology data were submitted with this supplement. Please see Pharmacology/Toxicology review memo from the original BLA for complete details.

##### 4.4 Clinical Pharmacology

Please refer to the Clinical Pharmacology review memo for this efficacy supplement for complete details.

#### 4.4.1 Mechanism of Action

ADYNOVATE temporarily replaces the missing clotting factor VIII needed for effective hemostasis in patients with hemophilia A. Upon activation of the clotting cascade, FVIII is converted to activated FVIII and acts as a cofactor for activated factor IX, accelerating the conversion of factor X to activated factor X on phospholipid surfaces, which ultimately converts prothrombin to thrombin and leads to the formation of a fibrin clot.

#### 4.4.2 Human Pharmacodynamics (PD)

Plasma FVIII activity, as measured by a validated (b) (4) activated partial thromboplastin time (aPTT) clotting assay, is the primary marker for PD/PK determinations of FVIII products in human clinical samples. Plasma clotting time as measured by the aPTT is prolonged in patients with Hemophilia A. Treatment with ADYNOVATE normalizes the aPTT.

#### 4.4.3 Human Pharmacokinetics (PK)

A nonlinear mixed effects model was used to develop a population PK model for ADYNOVATE to estimate individual PK parameters by empirical Bayesian estimates from the model. In a one-stage clotting assay, the clearance of ADYNOVATE was approximately 14% higher in children <6 years of age than children 6 to <12 years of age. Volume of distribution at steady state ( $V_{ss}$ ) of ADYNOVATE was comparable between children <6 and 6 to <12 years of age. In the chromogenic assay, the clearance of ADYNOVATE was approximately 15% higher in children <6 years of age than children 6 to <12 years of age. Volume of distribution at steady state of ADYNOVATE was about 15% higher in children <6 years of age than children 6 to <12 years of age. The clearance of ADYNOVATE in children <6 years of age, children 6 to <12 years of age, adolescents (12 to <18 years), and adults was  $3.53 \pm 1.29$ ,  $3.11 \pm 0.76$ ,  $2.73 \pm 0.93$ , and  $2.27 \pm 0.84$  mL/hour per kg, respectively. Compared with adults the clearance of ADYNOVATE in children <6 years of age and children 6 to <12 years of age is 55% and 37% higher, respectively.

### 4.5 Statistical

No interim analysis was performed. No statistical issues were noted in this supplement. Please refer to the Statistical review memo for full details.

### 4.6 Pharmacovigilance

The analyses of the safety data did not identify safety issues in the use of ADYNOVATE for the treatment of bleeding episodes, long-term use in pediatric patients and those undergoing perioperative management with severe hemophilia.

## 5. SOURCES OF CLINICAL DATA AND OTHER INFORMATION CONSIDERED IN THE REVIEW

### 5.1 Review Strategy

The review of this supplement was based on the clinical data provided in BLA 125566/51.

## 5.2 BLA/IND Documents That Serve as the Basis for the Clinical Review

Documents pertinent to this review were provided in 125566/51 and IND 15299, including the clinical summary, overview, and clinical study reports (Sections 2.5, 2.7, 5.3.5.).

## 5.3 Table of Studies/Clinical Trials

The completed, in-progress, and planned post-marketing clinical trials are summarized in **Table 3** below.

Table 3: List of Clinical Studies

Study Number	Short Study Title and Description	Study Status Report (if Available)	Sample Size <sup>a</sup>	Main Criteria for Inclusion	Dose Range and Frequency
261101	<b>BAX 855 Dose-escalation Safety</b> Phase 1, first-in-human, prospective, open label, crossover, dose-escalation study to evaluate safety and PK parameters of single doses of BAX 855 compared to single doses of ADVATE	Complete CSR 261101	19	PTPs <sup>b</sup> 18 to 65 years FVIII <1%	Two sequential dose cohorts: Cohort 1: Single administration of 30 IU/kg BW of ADVATE followed by administration of the same dose of BAX 855 after a wash-out period >96 h Cohort 2: Single administration of 60 IU/kg BW of ADVATE followed by administration of the same dose of BAX 855 after a wash-out period >96 h Acute bleeding episodes: treated with ADVATE
261201	<b>BAX 855 Pivotal</b> Phase 2/3, multicenter, open label, 2-arm study to evaluate efficacy, safety, and PK parameters of BAX 855 and HRQoL	Complete CSR 261201	138	PTPs <sup>b</sup> 12 to 65 years FVIII <1%	<u>Prophylaxis</u> : 45 ± 5 IU/kg BW twice weekly for ≥50 EDs <sup>c</sup> or 6 months ± 2 weeks, whichever occurs last <u>On-demand</u> : 10 - 60 ± 5 IU/kg BW for an approximate duration of 6 months <u>Acute bleeding episodes</u> : treated with BAX 855 <u>PK evaluation</u> : ADVATE and BAX 855 at prophylactic dose level
261202	<b>BAX 855 Pediatric</b> Phase 3 prospective, uncontrolled, multicenter study to evaluate PK, efficacy, safety, and immunogenicity of BAX 855	Complete CSR 261202	66 2 age groups (32 aged <6 years and 34 aged 6 to <12 years)	PTPs <sup>b</sup> <12 years FVIII <1%	<u>Prophylaxis</u> : 50 ± 10 IU/kg BW over a period of 6 months, or at least 50 EDs <sup>c</sup> <u>Acute bleeding episodes</u> : treated with BAX 855 <u>PK evaluation</u> : ADVATE and BAX 855 at 60 ± 5 IU/kg
Study Number	Short Study Title and Description	Study Status Report (if Available)	Sample Size <sup>a</sup>	Main Criteria for Inclusion	Dose Range and Frequency
261204	<b>BAX 855 Surgery</b> Phase 3, prospective, open label multicenter study of efficacy and safety of BAX 855 in surgical or other invasive procedures	Ongoing Interim CSR 261204	~50 major and minor surgeries or other invasive procedures in ~40 subjects to evaluate ≥ 10 major surgical/invasive procedures in ≥5 subjects	PTPs <sup>b</sup> 2 to 75 years FVIII <1%	<u>Surgical prophylaxis</u> : dose tailored to achieve FVIII target levels of 80 - 100% of normal for major and 30 - 60% of normal for minor surgeries
261302	<b>BAX 855 Continuation</b> Phase 3b, prospective, open label, multicenter continuation study of safety and efficacy of BAX 855 in the prophylaxis of bleeding	Ongoing	250 (200 evaluable)	PTPs <sup>b</sup> who completed another BAX 855 study or BAX 855 naïve ≤75 years FVIII <1%	<u>Fixed Prophylaxis</u> <sup>d</sup> depending on age, given twice weekly <u>OR</u> <u>PK-tailored Prophylaxis to maintain trough FVIII level ≥3%</u> <u>For at least 100 EDs</u>

Study Number	Short Study Title and Description	Study Status Report (if Available)	Sample Size <sup>a</sup>	Main Criteria for Inclusion	Dose Range and Frequency
261203	<b>BAX 855 PUPs</b> Phase 3, multi-center, open-label study to investigate safety and immunogenicity of BAX 855 in PUPs	Ongoing	120 (100 evaluable)	PUPs <6 years, FVIII <1%, who have undergone <3 EDs <sup>c</sup> with ADVATE, BAX 855 or FFP	<u>Prophylaxis</u> : to be initiated before the age of 3 years or once the subjects has experienced 2 joint bleeds before the age of 3 years, whichever occurs first; 25 – 80 IU/kg at least once weekly <u>On-demand</u> : only if subject is <3 years of age and has less than 2 joint bleeds; 10 – 80 IU/kg depending on bleeding severity In case of FVIII inhibitors: high-dose regimen of 100 - 200 IU/kg daily or low-dose regimen of 50 IU/kg 3 x/week with or without bypassing agents
261303	<b>BAX 855 PK-guided Prophylaxis</b> Phase 3, prospective, randomized, open-label multi-center clinical study to compare the safety and efficacy of PK guided BAX 855 treatment regimen targeting 2 different FVIII trough levels	Ongoing	116 to have 96 evaluable patients (48 per treatment arm)	PTPs <sup>b</sup> who completed another BAX 855 study; if BAX 855 naïve; 12 - 65 years of age with FVIII <1%	PK-guided BAX 855 dose to maintain FVIII target trough levels of 1 - 3% or approx. 10% (8 - 12%) FVIII trough level 1 - 3%: approximately twice weekly FVIII trough level approx. 10% (8% - 12%): every other day

Abbreviations: BW = body weight; CSR = clinical study report; ED = exposure day; FFP = fresh-frozen plasma; FVIII = factor VIII; HRQoL = health-related quality of life; IU = International Unit; PK = pharmacokinetics; PTP = previously treated patient; PUP = previously untreated patient.

<sup>a</sup> Actual sample size for completed studies, planned sample size for ongoing and projected studies.

<sup>b</sup> Previously-treated patient (PTP): subject has hemophilia A, and has been treated with FVIII product previously.

<sup>c</sup> An exposure day (ED) is defined as any calendar day on which at least one infusion of BAX 855 was administered.

<sup>d</sup> In Protocol Amendment 4 (version 2014MAY23) dosing was revised. The option for prophylaxis every 5 days (Q5d) and every 7 days (Q7d), which was based on the subject's previous regimen and low bleeding history, was replaced with the option for PK-tailored prophylaxis; however, subjects on Q5d and Q7d prophylaxis could remain on those regimens until completion.

Source: BLA 125566/51 Clinical Overview Module 2.5 Table 1 page 13-15/158

## 5.4 Consultations

No consultations were requested by the review team.

### 5.4.1 Advisory Committee Meeting (if applicable)

N/A

### 5.4.2 External Consults/Collaborations

External Consultation was not obtained.

## 5.5 Literature Reviewed (if applicable)

Montgomery RR, Gill JC, Scott JP. Hemophilia and von Willebrand's Disease (2003). In: Nathan and Oski's Hematology of Infancy and Childhood, 6th, Nathan DG, Orkin SH, Ginsberg D, Look AT (Eds), WB Saunders, Philadelphia.

Guidelines for the Management of Hemophilia (2012). *World Federation of Hemophilia*, [www.wfh.org](http://www.wfh.org).

## 6. DISCUSSION OF INDIVIDUAL STUDIES/CLINICAL TRIALS

### 6.1 Trial #1

A Phase 3 prospective, uncontrolled, multicenter study evaluating pharmacokinetics, efficacy, safety, and immunogenicity of BAX 855 (pegylated full-length recombinant FVIII) in previously treated pediatric patients with severe hemophilia A.

### 6.1.1 Objectives (Primary, Secondary, etc)

The primary objective was to assess the incidence of FVIII inhibitory antibodies ( $\geq 0.6$  Bethesda units [BU] using the (b) (4) Bethesda assay).

The secondary objectives were:

1. To evaluate the PK parameters of BAX 855 in pediatric PTPs <12 years of age
2. To monitor incremental recovery (IR) of BAX 855 over time
3. To evaluate hemostatic efficacy of BAX 855 in the management of acute bleeding episodes and for prophylaxis over a period of 6 months
4. To assess all AEs possibly or probably related to BAX 855
5. To evaluate immunogenicity (binding antibodies to FVIII, BAX 855, PEG and Chinese hamster ovary [CHO]) proteins and clinically significant changes in routine laboratory parameters (hematology, clinical chemistry and lipids) and vital signs

The exploratory objective was to evaluate changes in health-related quality of life (HRQoL) and health resource use.

### 6.1.2 Design Overview

This was a Phase 3, prospective, uncontrolled, multicenter, open-label study to investigate PK, hemostatic efficacy, safety, immunogenicity and HRQoL in at least 60 pediatric PTPs with severe hemophilia A.

There were to be 2 age cohorts of 30 subjects each (25 evaluable), with the following age ranges: <6 years and 6 to <12 years. Subjects were to be enrolled to receive twice weekly prophylactic treatment with  $50 \pm 10$  IU/kg of ADYNOVATE over a period of 6 months or at least 50 EDs, whichever occurred last. A subset of subjects (12 evaluable) within each age cohort was to undergo a PK evaluation prior to the start of prophylactic treatment.

Figure 1: Treatment Schema

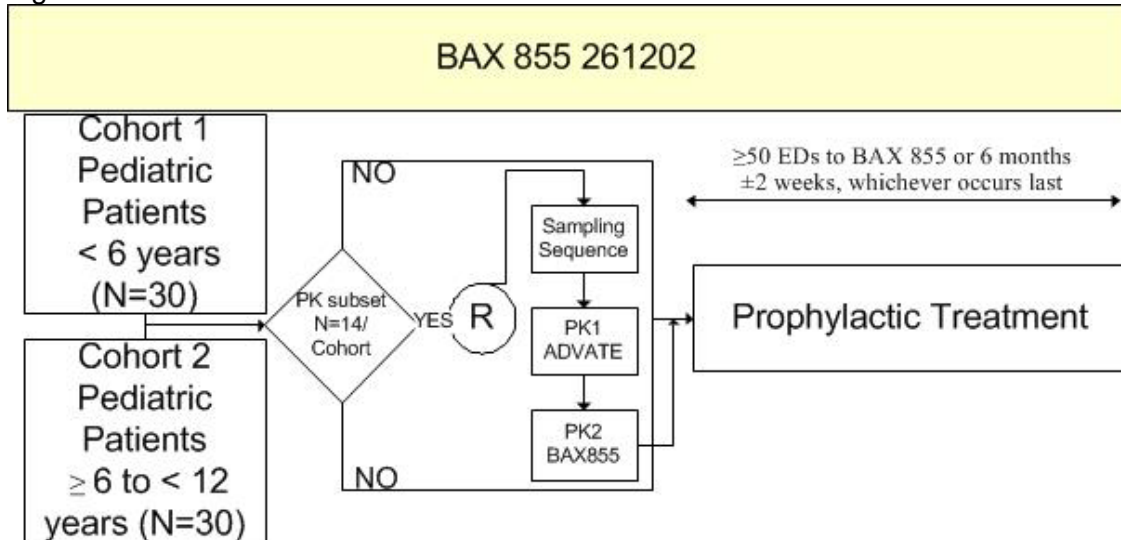

Source: BLA 125566/51 CSR 261202 page 44/1240

Treatment of breakthrough bleeds was with ADYNOVATE. The overall study duration was approximately 22 months from study initiation to study completion. After study completion, subjects were to have the option to transition into a continuation study to continue receiving ADYNOVATE until he/she accumulated a total of 100 EDs. Please see **Table 4** below.

Table 4: Study Procedures and Assessments

Schedule of Study Procedures and Assessments									
Procedures/ Assessments	Screening Visit	PK Assessments, if applicable			Baseline Visit	Prophylactic Treatment Study Visits			Study Completion/ Termination Visit <sup>a</sup>
		Pre infusion	Infusion	Post infusion		Week 5±1 or 10-15 EDs <sup>b</sup>	Week 12±2	Week 20 ±2 (By phone)	Month 6 ±2 weeks/ ≥50 EDs, whichever occurred last
Informed Consent <sup>c</sup>	X								
Eligibility Criteria	X								
Medical History, incl. Hemophilia History	X								
Laboratories <sup>d</sup>	X	X		X	X	X	X		X
Concomitant Medications <sup>e</sup>	X	X		X	X	X	X	X	X
Non-drug Therapies <sup>e</sup>	X	X		X	X	X	X	X	X
Adverse Events <sup>e</sup>		X		X	X	X	X	X	X
Bleeding Episodes <sup>e</sup>		X		X	X	X	X	X	X
Vital Signs <sup>f</sup>	X	X		X	X	X	X		X
Physical Exam <sup>g</sup>	X	X		X	X	X	X		X
IP Treatment <sup>h</sup>			X		X <sup>i</sup>	X	X		X
IP Dispense					X	X	X		
Issue subject diary	X								
Review subject diary		X		X	X	X	X	X	X
HRQoL <sup>j</sup>		X			X <sup>k</sup>				X
Health Resource Use <sup>l</sup>		X			X <sup>k</sup>	X	X		X

a. Included cases of withdrawal or discontinuation.

b At Week 5 ±1, or 10 to 15 EDs, whichever occurred last.

c. Occurred at enrollment (prior to any study-specific procedure).

d. At all assessments subjects were not to be actively bleeding. Assessments were only to be performed after a washout period of at least 72 hours following the infusion of ADVATE or any other non-modified FVIII concentrate and at least 84 to 96 hours following the infusion of BAX 855. In addition to the assessments shown, clinical laboratory assessments were to be performed whenever clinically indicated.

e Indicates that AEs, concomitant medications, non-drug therapies and bleeding episodes and their treatment were to be continuously monitored but specifically discussed and reviewed at these time points.

f Pulse, respiration, supine blood pressure and temperature were to be assessed within 15 minutes prior to start of infusion and 30 ±5 minutes following infusion. At baseline, and in the subset of subjects in the PK assessments, vital signs were also to be assessed 2 hours ±10 minutes after IP infusion.

g General appearance, head and neck, eyes and ears, nose and throat, chest, lungs, heart, abdomen, extremities and joints, lymph nodes, skin and neurological. Included height and weight at screening and weight at the pre-infusion assessments of each study visit and the presence/absence of target joints.

h BAX 855 was administered at the study site for PK assessment and the determination of IR. After a minimum washout period of 72 hours following the infusion of ADVATE and at least 84 to 96 hours after the last BAX 855 infusion, a pre-infusion blood sample was to be drawn and thereafter 60 ±5 IU/kg of ADVATE or BAX 855 administered, followed by a post-infusion blood draw at 15 to 30 minutes. Whenever possible, the IP treatment at the study site was to be in accordance with the subject's twice weekly BAX 855 prophylactic treatment regimen.

i For subjects undergoing PK assessments this was the first prophylactic infusion at a dose of 50 ±10 IU/kg; for those subjects NOT undergoing PK this was the first infusion of BAX 855 for FVIII IR determination at a dose of 60 ±5 IU/kg.

j HRQoL included: PedsQLTM, VAS Pain Scale, Patient Satisfaction Questionnaire and Physical Activity Question Set. The first HRQoL evaluation was to be performed during PK assessment with BAX 855 or baseline and at the Completion/Termination visit.

k Only for subjects who did not undergo PK assessment.

l Health Resource use included: hospitalization and length of stay, acute care visits, emergency room visits and days missed from school (ie, grade school, kindergarten, daycare).

Source: BLA 125566/51 CSR 261202 page 43/1240

### 6.1.3 Population

A total of 60 pediatric PTPs <12 years of age with severe Hemophilia A consisting of 30 subjects per age cohort were to be enrolled.

### 6.1.4 Study Treatments or Agents Mandated by the Protocol

Advate, ADYNOVATE

### 6.1.5 Directions for Use

The anticipated IV doses for prophylaxis were 40-60 IU/kg two times per week.



### 6.1.6 Sites and Centers

The trial was a multi-investigator, multicenter study. A total of 73 male subjects were enrolled at 39 investigational sites. 66 subjects were treated with at least one infusion of ADYNOVATE.

### 6.1.7 Surveillance/Monitoring

All study procedures were to be performed under direct supervision of the Investigator at the study site.

### 6.1.8 Endpoints and Criteria for Study Success

The primary outcome measure was the incidence of FVIII inhibitory antibodies. Secondary outcome measures included PK, hemostatic efficacy (measured by ABR, consumption of study drug, number of infusions per bleeding episode), safety, and exploratory outcome measures (Pediatric Quality of Life Inventory).

The rating scale for efficacy is below in **Table 5**:

Table 5: Efficacy Rating Scale for Treatment of Bleeding Episodes

<b>Efficacy Rating Scale for Treatment of Bleeding Episodes</b>	
Excellent	Full relief of pain and cessation of objective signs of bleeding (eg, swelling, tenderness and decreased range of motion in the case of musculoskeletal hemorrhage) after a single infusion. No additional infusion is required for the control of bleeding. Administration of further infusions to maintain hemostasis would not affect this scoring.
Good	Definite pain relief and/or improvement in signs of bleeding after a single infusion. Possibly requires more than 1 infusion for complete resolution.
Fair	Probable and/or slight relief of pain and slight improvement in signs of bleeding after a single infusion. Required more than 1 infusion for complete resolution.
None	No improvement or condition worsens.

Source: BLA 125566/51 CSR 261202 page 48/1240

### 6.1.9 Statistical Considerations & Statistical Analysis Plan

Please refer to the Statistical review memo for details.

The full analysis set (FAS) contained all subjects in the all subjects enrolled (ENR) set who received at least one dose of BAX 855 in either the PK part of the study or prophylaxis part of the study.

The efficacy of ADYNOVATE in the treatment of bleeds was to be summarized. This summary included overall hemostatic efficacy rating at resolution of bleed, number of infusions to control bleeding and total weight-adjusted dose per bleeding episode excluding any infusions given to maintain hemostasis after the bleeding was controlled. The proportion of bleeds including 95% CIs for the proportion of bleeds with an efficacy rating of "Excellent" and "Good" (summarized as one entity) was to be presented. The CI was to be determined using an exact Clopper-Pearson test.

All outcome measures descriptive statistics were to be presented by age. Point estimates (mean or median) and 95% confidence intervals (CIs) were computed. A Clopper-Pearson exact 95% CI was to be calculated for the number of subjects who developed inhibitory antibodies to FVIII. The ABR was to be analyzed in a generalized linear model framework assuming a negative binomial distribution with a logarithmic link function and presence or absence of target joints and age at screening <6 years versus 6 to <12 years as covariates, and the duration of the observation period in years as an offset. Point estimates and 95% CIs were to be estimated based on the model.

6.1.10 Study Population and Disposition

Seventy-three subjects enrolled in the study. Thirty-one subjects were dosed in the PK part of the study (14 were <6 years and 17 were 6 to <12 years). Sixty-six subjects received at least one infusion of ADYNOVATE. Sixty-one of sixty-six subjects had received FVIII prophylaxis prior to the study. Sixty-four subjects completed the study. One subject was female. The mean (SD) number of EDs to ADYNOVATE was 54 (±7.7) (median: 55; range: 9.0-65.0). Sixty-two subjects had at least 50 EDs to ADYNOVATE.

There were 9 screen failures. Among these, 2 subjects were initial screen failures but fulfilled the inclusion/exclusion criteria later and entered the study. Two subjects discontinued participation during the study. One subject was withdrawn due to deviations from the inclusion/exclusion criteria. One subject was withdrawn because the subject had increased number of bleeds.

The subject disposition is represented in **Figure 2** below:

Figure 2: Subject Disposition

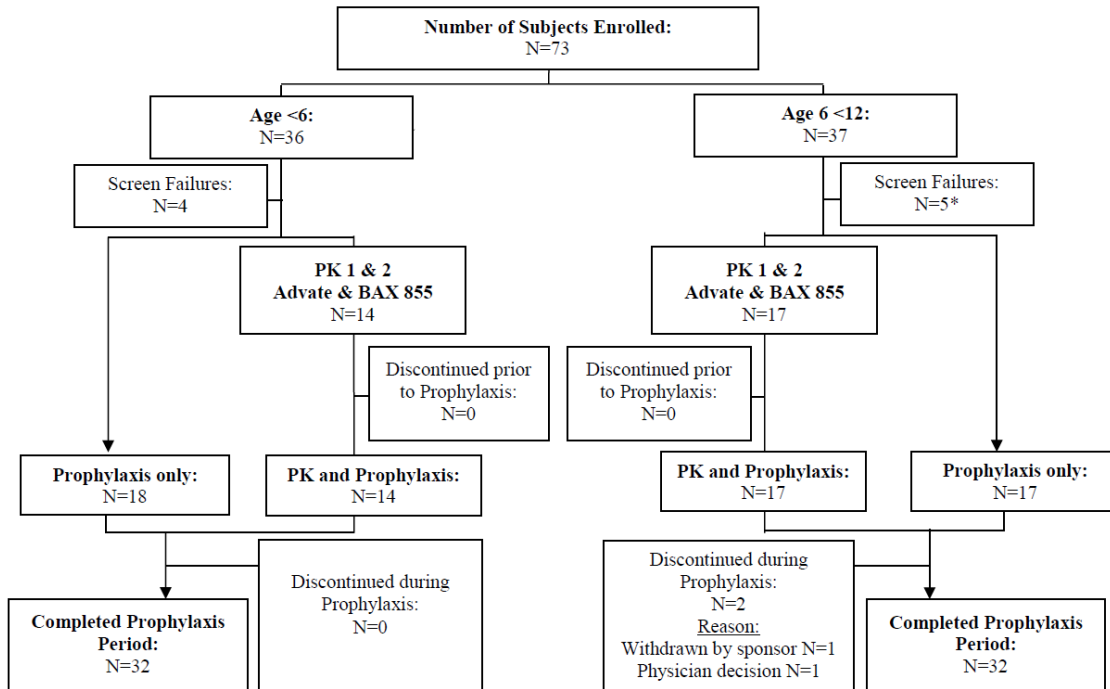

Source: BLA 125566/51 CSR 261202 page 67/1240

#### 6.1.10.1 Populations Enrolled/Analyzed

A full analysis set (FAS) contained all subjects enrolled who received at least one dose of ADYNOVATE in either the PK part of the study or prophylaxis part of the study. All efficacy analyses were performed on the FAS. The FAS was the primary analysis set.

The Per Protocol Analysis Set (PPAS) contained all subjects in the FAS who fulfilled the following compliance criteria for prophylactic treatment:

- Infusion interval of 5 or more days did not occur more than 5 times in the Observation Period
- The daily dose was below 40 IU/kg in no more than 10% of the infusions in the Observation Period.
- The daily dose was above 80 IU/kg in no more than 10% of the infusions in the Observation Period.

There were 66 subjects in the FAS and 65 subjects in the PPAS. One subject did not qualify for the PPAS because this subject received doses below 40 IU/kg for more than 10% of infusions. A total of 62 subjects had 50 EDs to ADYNOVATE.

#### 6.1.10.1.1 Demographics

The majority of subjects were White (65.2%) followed by Asians (25.8%). The demographic and baseline data are in Table 6 below:

Table 6: Demographics

	Statistic	Age < 6 (N = 32)	Age 6 to <12 (N = 34)	Total (N = 66)
Age (Years)	n	32	34	66
	Mean (SD)	3.7 (1.17)	8.1 (1.92)	6.0 (2.70)
	Median	4.0	8.0	6.0
	IQR (Q1, Q3)	2.00 (3.00, 5.00)	3.00 (6.00, 9.00)	4.00 (4.00, 8.00)
	Minimum, Maximum	1, 5	6, 11	1, 11
<b>Sex</b>				
Male	n (%)	32 (100.0)	33 (97.1)	65 (98.5)
Female	n (%)	0 (0.0)	1 (2.9)	1 (1.5)
<b>Race</b>				
Asian	n (%)	10 (31.3)	7 (20.6)	17 (25.8)
Japanese	n (%)	1 (3.1)	0 (0.0)	1 (1.5)
Chinese	n (%)	2 (6.3)	2 (5.9)	4 (6.1)
Indian	n (%)	2 (6.3)	0 (0.0)	2 (3.0)
Other	n (%)	5 (15.6)	5 (14.7)	10 (15.2)
Black Or African American	n (%)	2 (6.3)	2 (5.9)	4 (6.1)
White	n (%)	18 (56.3)	25 (73.5)	43 (65.2)
Other	n (%)	1 (3.1)	0 (0.0)	1 (1.5)
Other	n (%)	1 (3.1)	0 (0.0)	1 (1.5)
Multiple	n (%)	1 (3.1)	0 (0.0)	1 (1.5)

Source: BLA 125566/51 CSR 261202 page 164/1240

#### 6.1.10.1.2 Medical/Behavioral Characterization of the Enrolled Population

The average historical ABR was 8.5. Only five of the 66 subjects were previously on on-demand treatment and had seven or more bleeding episodes per year prior to the study. Fourteen of the subjects had at least one target joint at screening.

6.1.10.1.3 Subject Disposition

Twenty-five subjects had no bleeding episodes. Out of the remaining 41 with at least one bleeding episode, 31 had no target joints. The historical ABR was higher in subjects with at least one bleeding episode (10.9 versus 4.5) than in subjects with no bleeds during the study.

6.1.11 Efficacy Analyses

The primary endpoint included inhibitor development. The primary measure of hemostatic efficacy was the ABR. Please see below for details.

6.1.11.1 Analyses of Primary Endpoint(s)

Immunogenicity assessments were to include inhibitory antibodies to FVIII and binding antibodies to FVIII, PEG-FVIII, PEG, and CHO proteins. Please refer to safety section for analysis of these data.

6.1.11.2 Analyses of Secondary Endpoints

The ABR was analyzed for those <6 years and 6 to <12 years. The median ABR was 2 (range 0, 49.8) in all subjects. In subjects 6 to <12 years, the median was 2 (range 0, 49.8). The younger group (<6 years) had a median ABR of 1.95 (range: 0, 18.4). The following **Table 7** shows the ABR.

Table 7: ABR for the Pediatric Cohort

Parameter	Statistic	Statistic Unit	Age < 6 (N = 32)	Age 6 to <12 (N = 34)	Total (N = 66)
Annualized Bleeding Rate	Number of Subjects	n	32	34	66
	Bleeding Rate per Subject	Mean (SD)	2.40 (3.508)	4.76 (9.046)	3.61 (6.988)
		Median	1.95	2.00	2.00
		IQR (Q1, Q3)	3.850 (0.000, 3.850)	5.900 (0.000, 5.900)	3.900 (0.000, 3.900)
		Minimum, Maximum	0, 18.4	0, 49.8	0, 49.8
	Patients Included in Analysis		32	34	66
	Point Estimate for Mean		2.37	3.75	3.04
95% Confidence Interval for the Mean		[1.486 - 3.778]	[2.429 - 5.781]	[2.208 - 4.186]	

IQR = Inter quartile range. Q1 = First quartile. Q3 = Third quartile. SD = Standard deviation.  
N = Total number of subjects in the relevant analysis set.  
Point estimate and 95% confidence intervals obtained from a generalized linear model assuming a negative binomial distribution with logarithmic link function. The model includes the presence or absence of target joints and age category (< 6 versus ≥ 6 - <12) as covariates and the duration of the observation period as an offset.

Source: BLA 125566/51 CSR 261202 Source: Table 33 pg 77/1240

*Reviewer Comment: One subject with an ABR of 49.8 experienced two injuries at the left knee, but not specified as a target joint. The subject was withdrawn after 22 days of treatment upon the physician's decision.*

The median ABR for joint bleeds was 0 (IQR: 0, 1.9). The median ABR for target joint bleeds was 0 (IQR 0, 0). The median ABR of spontaneous bleeds was 0 (IQR: 0, 1.9). The median ABR for injury-related bleeds was 1.8. (0, 49.8)

During the 6-month prophylactic treatment, 25/66 (38%) subjects had no bleeding episodes. Overall, 48/66 (73%) had no joint bleeds. A total of 5/66 (8%) subjects had at least 1 target joint bleed (4 subjects in the older age cohort).

A total of 22/66 (33%) subjects had one or more spontaneous bleeds. The majority of spontaneous bleeds (87%) were treated with one infusion only. Overall, spontaneous bleeds had an efficacy rating of "excellent" or "good". Three bleeds were not reported. One was rated as fair. See **Table 8** below.

*Reviewer Comment:*

*There were 6 subjects that had 2 or more spontaneous bleeding episodes. For two of the subjects, the spontaneous bleeds occurred after an injury. All of the subjects had to be treated with ≥3 infusions of ADYNOVATE. This is appropriate for such an event and would now affect the interpretation of the data.*

Table 8: Bleeding Episodes in Pediatric Cohort

Parameter	Statistic	Age < 6 (N = 32)	Age 6 to <12 (N = 34)	Total (N = 66)
At Least One Bleeding Episode	n (%)	19 (59.4)	22 (64.7)	41 (62.1)
No Bleeding Episodes	n (%)	13 (40.6)	12 (35.3)	25 (37.9)
≤1 Bleeds	n (%)	22 (68.8)	19 (55.9)	41 (62.1)
At Least One Joint Bleed	n (%)	7 (21.9)	11 (32.4)	18 (27.3)
No Bleeds in Any Joint	n (%)	25 (78.1)	23 (67.6)	48 (72.7)
At Least One Target Joint Bleed	n (%)	1 (3.1)	4 (11.8)	5 (7.6)
No Bleeds in Target Joint	n (%)	31 (96.9)	30 (88.2)	61 (92.4)
At Least One Spontaneous/Unknown Bleed	n (%)	11 (34.4)	11 (32.4)	22 (33.3)
No Spontaneous/Unknown Bleeds	n (%)	21 (65.6)	23 (67.6)	44 (66.7)

n = Number of subjects in each category. N = Total number of subjects in the relevant analysis set.

% = Percentage of subjects in each category relative to the number of subjects in the relevant analysis set.

Source: BLA 125566/51 CSR 261202 Source: Table 51 pg 93/1240

Seventy treated bleeding episodes occurred in 34 subjects (25 episodes in 15 subjects <6 years and 45 treated episodes in 19 subjects of 6 to <12 years). A mean of 1.3±0.55

infusions were administered per bleed. Six bleeds were treated with 2 infusions and 6 bleeds were treated with 3 or more infusions. The mean average dose per infusion to treat a bleed was  $43.2 \pm 13.95$ . Bleeds were either minor or moderate in severity. No major bleeds occurred during prophylaxis. The overall mean time between the previous prophylactic infusion and the occurrence of bleeds was  $49.9 \pm 33.4$  hours.

Efficacy in the control of bleeding was defined as a rating of “excellent” or “good” in 63/70 (90%) of bleeds. Hemostatic efficacy was rated “fair” in 4/70 (5.7%) bleeding episodes in 2 subjects.

*Reviewer Comment:*

*There were 15 subjects that had bleeding episodes that were not treated with ADYNOVATE. Most of these episodes were categorized as minor in severity. This observation does not affect the interpretation of the data.*

The 66 subjects received a mean dose of  $51.1 \pm 5.5$  IU/kg (median 51.3; range 39.9-66.8) per prophylactic infusion. In those <6 years, the mean dose was  $51.3 \pm 4.9$  IU/kg (median 51.6; range 42.3-61.3). In subjects aged 6 to <12 years, the mean dose was  $51 \pm 6.0$  IU/kg (median 50.4; range 39.9-66.8).

*Reviewer Comment: After an information request to clarify the dosing for PTPs in this study, it was noted that those aged 2 to <6 years were dosed ranging from 43 IU/kg to 73 IU/kg and those aged 6 to <12 years received 42 IU/kg to 81 IU/kg. This data indicated that 50% required a dose >55 IU/kg in the younger age cohort. In the older age cohort, 32% required a dose >55 IU/kg. This dosing is higher than the proposed dose in the proposed prescribing information (PI) for those <12 years (40 -60 IU/kg). This clinical reviewer recommends a dose of 55-70 IU/kg twice weekly of ADYNOVATE to be administered to children <12 years.*

#### 6.1.11.3 Subpopulation Analyses

Thirty-three subjects had been on a regimen of three prophylactic infusions per week prior to entering the study. Their mean ABR decreased from 3.91 to 2.28 with twice weekly prophylaxis.

Fourteen of sixty-six (21.2%) subjects had at least one target joint at screening. Among the three subjects in the <6 years age cohort who had one target joint at screening, the target joint disappeared in two subjects during the course of the study. In the 11 subjects of the older cohort, two of three who had one target joint lost their target joint during the study. Four of seven who had two target joints lost both target joints and one lost one target joints. The subject who had three target joints lost two during the study. No new target joints developed during the study.

#### 6.1.11.4 Dropouts and/or Discontinuations

Seven major protocol deviations occurred in five subjects. The deviations included three involving the informed consent/assent, one deviation where a subject had only 89 pre-study exposure days (did not meet criteria of 150EDs) to FVIII and resulted in discontinuation by the sponsor, two deviations involving drug accountability, and one deviation included using vials of study drug from different lots.

#### 6.1.11.5 Exploratory and *Post Hoc* Analyses

Quality of life analyses formed part of the exploratory objectives of this study. The assessment of HRQoL, based on relevant questionnaires, was captured in electronic diaries.

In the overall population (FAS), an improvement over baseline was observed in the following domains: physical functioning, school functioning, psychosocial health summary, and physical health summary. For emotional functioning and social functioning, scores showed improvement, as well.

In the <6 years cohort, no trend could be observed in the change of QoL scores from baseline for subjects who had no bleeds compared to subjects who had bleeds during the study. Mean emotional functioning and social functioning scores were higher in subjects with no bleeds while mean physical functioning and school functioning scores were higher for subjects with bleeds during the study. In the 6 to <12 years cohort, an improvement over baseline was achieved by subjects with and without bleeding episodes during the study. Additionally, in this age cohort, mean improvement for the subjects without bleeding episodes was higher for all domains than mean improvement for subjects with bleeding episodes during the study.

#### 6.1.12 Safety Analyses

##### 6.1.12.1 Methods

The safety analyses were performed on the 66 subjects who received at least one infusion of ADYNOVATE. Each AE was to be evaluated by the investigator for seriousness, severity and causal relationship to drug exposure. Immunogenicity assessments were to include inhibitory antibodies to FVIII and binding antibodies to FVIII, PEG-FVIII, PEG, and CHO proteins. Binding antibodies to FVIII and PEG-FVIII, as well as to PEG, were to be measured using ELISA. Both immunoglobulin G (IgG) and immunoglobulin M (IgM) binding antibodies for FVIII, PEG-FVIII and PEG were to be routinely tested.

##### 6.1.12.2 Overview of Adverse Events

ADYNOVATE was safe and well tolerated in 66 treated subjects. None of the subjects developed anti-FVIII inhibitory antibodies. There was no death in this study. No SAEs were assessed by the investigator or the sponsor as related to ADYNOVATE treatment. There were no thrombotic AEs or AEs considered allergic reactions.

During treatment, 156 AEs (of which 152 were non-serious) occurred in 43 (65.2%) subjects. One AE in one subject was assessed by the investigator as related to ADYNOVATE, but was judged as not related by the sponsor. Four SAEs were reported in three subjects: three SAEs were of moderate severity (febrile neutropenia, pancytopenia and acute gastritis); one SAE was severe (abdominal pain). The most frequently reported AEs were infections and infestations followed by GI disorders and administration site conditions.

*Reviewer Comment: One moderate non-serious event of urticaria occurred 0.25 hours following the infusion and lasted for one day and was assessed by the investigator as an allergic reaction possibly related to ADYNOVATE. This subject has a medical history of atopy with ongoing allergic eosinophilia, eczema, asthma, allergic rhinitis, atopic dermatitis, and allergic conjunctivitis. As the subject had this significant history, this reviewer judges this event likely related to the study drug due to the timing of infusion and AE and as there were no other details provided of other sources of the urticarial reaction.*

One subject aged < 6 years had inhibitory antibodies to FVIII at screening which was not confirmed upon re-testing. For seven subjects, the inhibitor titer at screening could not be determined due to insufficient quantity of samples, presence of fibrin clots, or no specimen was received. At completion of the study, the inhibitor titer could not be determined in seven subjects. One of these subjects was withdrawn.

Four of the seven subjects were included in the primary analysis to determine the incidence of the inhibitor development whereas all seven subjects were included in the secondary analysis. Three subjects were excluded due to an insufficient quantity of plasma to test for inhibitors or the subjects only had 40 EDs.

*Reviewer Comment: Since the primary endpoint was inhibitor rate, those subjects who had no inhibitor titer at screening should not have been enrolled. For those that did not have an inhibitor titer at completion, six subjects had results for binding antibodies to FVIII and PEG-FVIII which were negative and would exclude the presence of an inhibitory antibody to FVIII.*

#### 6.1.12.3 Deaths

There were no deaths that occurred during the study.

#### 6.1.12.4 Nonfatal Serious Adverse Events

Four SAEs occurred in 3/66 of subjects. The first subject with moderate acute gastritis, the second had severe abdominal pain, and the third had moderate febrile neutropenia and moderate pancytopenia.

*Reviewer Comment: These SAEs are judged to be not related to the study drug. The first subject was diagnosed with gastritis approximately 12 hours after the study drug infusion. The second subject had acute abdominal pain and administration of study drug was temporally related. This subject was subsequently hospitalized and diagnosed with enterocolitis. This is judged unlikely related to the study drug. All subjects continued to receive the study drug without any other AEs. The third case of febrile neutropenia and pancytopenia also had a temporal relationship after study drug administration. The subject received antibiotics and recovered. This is also unlikely related to study drug and most likely viral suppression.*

#### 6.1.12.5 Adverse Events of Special Interest (AESI)

N/A



#### 6.1.12.6 Clinical Test Results

For all parameters, the majority of subjects had normal values at baseline and subsequent visits. One subject had an elevation in alkaline phosphatase during an episode of febrile neutropenia. This elevation was transient and resolved. One subject had an elevation in eosinophils which was related to an asthma exacerbation.

#### 6.1.12.7 Dropouts and/or Discontinuations

One subject was withdrawn by the physician 22 days after the first administration of ADYNOVATE due to insufficient response. The subject experienced two moderate soft tissue injuries to the left knee at 59.5 h and 55.5 h after prophylactic infusion which resolved after one and three infusions, respectively, of ADYNOVATE of 44 IU/kg each. A minor skin injury at 24 h after prophylactic infusion resolved after one infusion of 44 IU/kg.

*Reviewer Comment: The withdrawn subject had previously been on weekly prophylaxis and historical ABR of 1. The left knee bleed was trauma-related and the efficacy rating was fair due to the ongoing pain and swelling. It is unclear based on the report if the second bleed in the same location three days after the first was a rebleed or a new bleed. The bleed was reported to be resolved four days later. The infusion frequency for this subject was below the twice-weekly prophylactic schedule to be followed per protocol and may not have been sufficient to prevent injury-related bleeding.*

#### 6.1.13 Study Summary and Conclusions

ADYNOVATE was safe and well-tolerated in 66 pediatric PTPs with severe hemophilia A who received the drug twice weekly for prophylaxis and treatment of bleeding episodes. None of the subjects developed inhibitory antibody to FVIII ( $\geq 0.6$  BU) following treatment with BAX 855 (95% CI: 0.0000, 0.0627,  $n = 57$ ). Sixteen subjects showed a pre-existing antibody against FVIII (2), PEG-FVIII (14) or PEG (1) prior to first exposure of ADYNOVATE. Five subjects tested positive for binding antibodies after exposure to ADYNOVATE. Antibodies were transient and not detectable at subsequent time points or at completion of the study for two of those subjects. Another two subjects developed binding antibodies at completion of the study, and one subject had positive binding antibodies at Week 5, Week 12 and at study completion. No conclusion can be drawn regarding whether the binding antibodies in these three subjects are of transient or persistent nature. No impact on hemostatic efficacy or safety was observed in any of these subjects. Antibody response in the latter subjects will continue to be monitored in the continuation study. A total of four SAEs in three subjects were reported and were assessed as not related to the study drug. No thrombotic AEs and no AEs considered allergic reactions occurred. There was no trend toward abnormalities over time in the laboratory parameters.

## 6.2 Trial #2

A phase 3, multicenter, open-label study of efficacy and safety of PEGylated rFVIII in previously treated patients with severe Hemophilia A undergoing surgical or other invasive procedures.

*Reviewer Comment: An interim report was submitted with this BLA supplement as the applicant had submitted data including 10 major surgeries in 5 subjects. This was agreed upon in a pre-BLA meeting. Please see Section 2.5 above for details.*

#### 6.2.1 Objectives (Primary, Secondary, etc)

The primary objective is to evaluate the perioperative hemostatic efficacy of ADYNOVATE in male PTPs with severe hemophilia A undergoing major or minor elective or emergency surgical, dental, or other invasive procedure as determined by the global hemostatic efficacy assessment (GHEA) score.

The primary outcome measure is the Global Hemostatic Efficacy Assessment (GHEA) score, which is composed of 3 individual ratings:

- Assessment of intraoperative hemostatic efficacy of ADYNOVATE performed by the operating surgeon
- Assessment of postoperative hemostatic efficacy of ADYNOVATE performed on postoperative Day 1 (i.e., the day following the day of surgery) by the operating surgeon
- Assessment of perioperative hemostatic efficacy of ADYNOVATE performed by the investigator at discharge or on postoperative Day 14 (whichever is first)

*Reviewer Comment: The scores of the 3 individual ratings were added together to form a GHEA score. For a GHEA score to be rated "excellent", no individual assessment score should be less than 2. The rating assessments are included in Appendix 1 below.*

Secondary objectives included:

- To determine intra- and post-operative blood loss, volume of blood, red blood cells, platelets, and other blood products transfused, the occurrence of bleeding episodes and additional need for surgical intervention, and daily and total weight-adjusted consumption of BAX 855 per subject.
- To determine the safety of BAX 855 in subjects undergoing surgery, as assessed by occurrence of AEs and changes in vital signs and clinical laboratory parameters.
- To determine the PK parameters prior to major surgeries.
- To determine the Incremental Recovery (IR) following the initial bolus infusion prior to surgery.

#### 6.2.2 Design Overview

This was a phase 3, prospective, open-label, single group, uncontrolled, multicenter study to evaluate the efficacy and safety of ADYNOVATE in approximately 40 male PTPs, 2-75 years of age, with severe Hemophilia A who are undergoing approximately 50 major or minor surgeries. The goal was to evaluate 10 major surgical/invasive procedures in at least five subjects.

The study was to be divided into five periods: screening; preoperative, including PK assessment; intraoperative; postoperative; end of study.

Major and Minor surgeries were defined as the following:

Major: involved surgeries which require moderate or deep sedation, general anesthesia, or major conduction blockade for patient comfort and comprise major orthopedic (e.g., joint replacement), major abdominal, intracranial, cardiovascular, spinal and any other surgery which has a significant risk of large volume blood loss or blood loss into a confined anatomical space. Extractions of several teeth or extraction of the third molar and adeno-tonsillectomy in children were considered as major. In addition, minor surgeries/interventions are expected to require clinical surveillance or hospital treatment  $\geq 3$  days after the surgery/intervention.

Minor: comprised surgeries which can be safely and comfortably performed on a patient who has received local or topical anesthesia, without more than minimal preoperative medication or minimal intraoperative sedation. In addition, minor surgeries/interventions are expected to require clinical surveillance or hospital treatment  $\leq 3$  days after the surgery/intervention.

Study completion was to be defined by the end of study visit after discharge or once the subject resumed his previous treatment regimen, whichever occurred last.

### 6.2.3 Population

The main criteria for inclusion were a diagnosis of severe hemophilia and previous treatment with FVIII concentrated for  $\geq 150$  EDs.

The main criteria for exclusion were the presence of detectable FVIII inhibitory antibodies, history of inhibitory antibodies, and the need for major emergency surgery.

### 6.2.4 Study Treatments or Agents Mandated by the Protocol

Before major surgeries were performed, individual PK parameters were to be assessed over 96 hours following a single  $60 \pm 5$  IU/kg dose of ADYNOVATE. Of note, vials from different lots and potencies were not to be allowed for the PK infusion. If subjects had undergone PK determination in the parent study, then this assessment was not performed.

Within 60 minutes before initiating surgery, subjects received a loading dose of ADYNOVATE to raise the pre-infusion plasma level of FVIII to 80-100% of normal for major and to 30-60% of normal for minor procedures. Peak levels were not to exceed 180%. The dose and frequency of ADYNOVATE administered was individualized based on the subject's PK parameters. All subsequent infusions of ADYNOVATE were preceded by measurement of residual FVIII levels and dose adjustments were based on the most recent residual FVIII activity levels.

The dosing recommendations are in **Figure 3** below:

Figure 3: Dosing for Surgery  
**Dosing Recommendations for Major Surgeries**

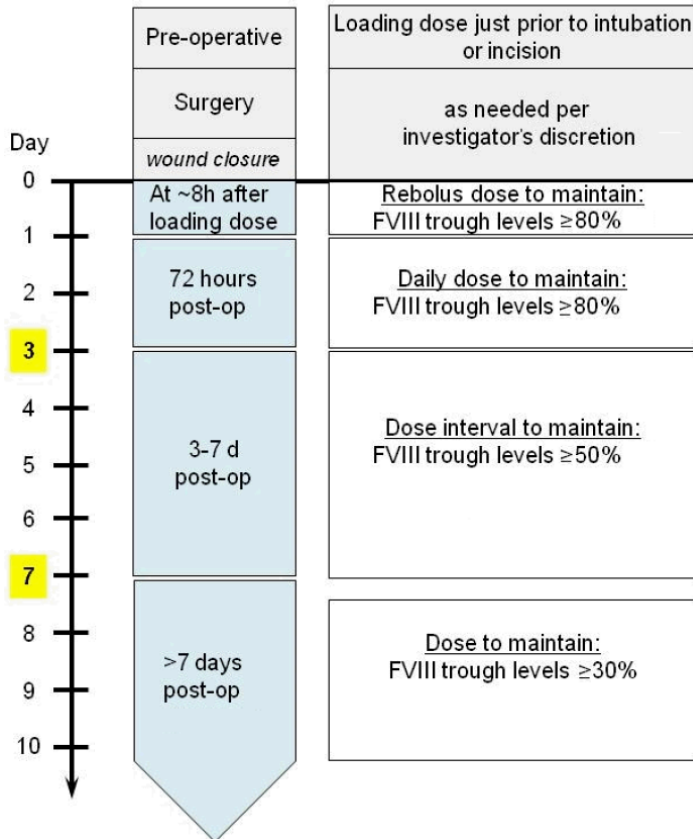

Source: BLA 125566/51 CSR 261204 Source: Figure 9.4-1 pg 26/140

### 6.2.5 Directions for Use

ADYNOVATE is formulated as a sterile, highly purified protein preparation in lyophilized form for intravenous infusion and is provided in single-dose vials, which contain nominally 250, 500, 1000, and 2000 IU rFVIII/vial, along with a vial of diluent (5 mL SWFI). Single-dose vials with a nominal potency of 3000 IU rFVIII/vial and 2 mL sterile water for injection were to be added during the course of the study. For the PK assessment, only 500 IU vials of the same batch are to be used (or 1000 IU vials of the same batch, if 500 IU vials are not available).

### 6.2.6 Sites and Centers

The 16 subjects in the safety analysis set were enrolled at 11 sites in seven countries (Bulgaria, Lithuania, Russia, Spain [two sites], Switzerland, United Kingdom, United States [four sites]).

### 6.2.7 Surveillance/Monitoring

All study procedures were to be performed under direct supervision of the Investigator at the study site.

### 6.2.8 Endpoints and Criteria for Study Success

The primary outcome measure was the Global Hemostatic Efficacy Assessment (GHEA)

score, which is composed of three individual ratings:

- 1) Assessment of intraoperative hemostatic efficacy of BAX 855 performed by the operating surgeon
- 2) Assessment of postoperative hemostatic efficacy of BAX 855 performed on postoperative Day 1 (i.e., the day following the day of surgery) by the operating surgeon
- 3) Assessment of perioperative hemostatic efficacy of BAX 855 performed by the investigator at discharge or on postoperative Day 14 (whichever is first)

#### 6.2.9 Statistical Considerations & Statistical Analysis Plan

The sample size of approximately 50 major and minor surgeries or other invasive procedures in approximately 40 subjects to evaluate a minimum of 10 major surgical/invasive procedures in at least five subjects was to be determined by the number of subjects requiring major elective and minor emergency or elective surgical, dental or other invasive procedures and not to be based on statistical considerations.

#### 6.2.10 Study Population and Disposition

##### 6.2.10.1 Populations Enrolled/Analyzed

There were 21 subjects enrolled. Two subjects were re-enrolled twice. Of the 21 subjects, 15 subjects completed the study following treatment with ADYNOVATE and underwent one procedure.

There were five subjects who did not complete the study at the data cut-off for this report: one screen failure, three were undergoing screening procedures, and one was withdrawn (the subject who was reenrolled).

The first subject who enrolled twice was withdrawn from the study after the PK assessment due to adverse events (diabetes-induced gastroparesis). No surgery was performed. The second subject underwent minor dermatological surgery. At the time of re-enrollment, the subject was undergoing screening procedures for a second surgery at the time of data cut-off.

A total of 17 subjects were exposed to ADYNOVATE and 15 underwent surgery. There were 11 major and four minor surgeries. All 15 subjects who underwent surgery completed the study and were included in the full analysis set.

The 11 major surgeries comprised six orthopedic (three knee replacements, two arthroscopic synovectomies, one elbow cyst extirpation) and five non-orthopedic procedures (three dental [multiple tooth extractions including one radicular cyst removal], one cardiovascular [mediport placement], one abdominal [gastric band insertion]). The four minor surgeries comprised one orthopedic (synoviorthesis), one dental, one dermatological and one endoscopy (radiosynovectomy) procedure.

##### 6.2.10.1.1 Demographics

Table 9: Demographics in Surgery Study

Demographic and Baseline Characteristics - discrete data (BAX 855 Surgery 261204: Safety Analysis Set)					
Parameter	Category	Major Surgeries N = 11 n (%)	Minor Surgeries N = 4 n (%)	Not done N = 2 n (%)	All Surgeries N = 17 n (%)
Severity of Hemophilia	Severe	10 (90.9)	4 (100.0)	2 (100.0)	16 (94.1)
	Not Severe	1 (9.1)	0 (0.0)	0 (0.0)	1 (5.9)
	Not Reported	0 (0.0)	0 (0.0)	0 (0.0)	0 (0.0)
Gender	All	11 (100.0)	4 (100.0)	2 (100.0)	17 (100.0)
	Male	11 (100.0)	4 (100.0)	2 (100.0)	17 (100.0)
	Female	0 (0.0)	0 (0.0)	0 (0.0)	0 (0.0)
Race	All	11 (100.0)	4 (100.0)	2 (100.0)	17 (100.0)
	Asian	0 (0.0)	1 (25.0)	0 (0.0)	1 (5.9)
	Black or African American	0 (0.0)	0 (0.0)	0 (0.0)	0 (0.0)
Race	White	11 (100.0)	3 (75.0)	2 (100.0)	16 (94.1)
	All	11 (100.0)	4 (100.0)	2 (100.0)	17 (100.0)
	Non-White	0 (0.0)	1 (25.0)	0 (0.0)	1 (5.9)
Ethnicity	All	11 (100.0)	4 (100.0)	2 (100.0)	17 (100.0)
	Non-Hispanic	10 (90.9)	3 (75.0)	2 (100.0)	15 (88.2)
	Hispanic	1 (9.1)	1 (25.0)	0 (0.0)	2 (11.8)
Geographical Region	All	11 (100.0)	4 (100.0)	2 (100.0)	17 (100.0)
	Eastern Europe <sup>a</sup>	7 (63.6)	0 (0.0)	0 (0.0)	7 (41.2)
	Western Europe <sup>b</sup>	2 (18.2)	2 (50.0)	0 (0.0)	4 (23.5)
	North America	2 (18.2)	2 (50.0)	2 (100.0)	6 (35.3)
	Not reported	0 (0.0)	0 (0.0)	0 (0.0)	0 (0.0)

Source: BLA 125566/51 CSR 261204 Source: Table 4 pg 80/140

#### 6.2.10.1.2 Medical/Behavioral Characterization of the Enrolled Population

All subjects were PTPs with Hemophilia A. All subjects, except one, had severe HA.

#### 6.2.10.1.3 Subject Disposition

Five subjects were previously treated in BAX 855 pivotal study 261201, and three of these were also treated in BAX 855 continuation study 261302. The remaining 11 subjects were newly recruited into this surgery study.

The subject disposition in **Figure 4** is below:

Figure 4: Subject Disposition

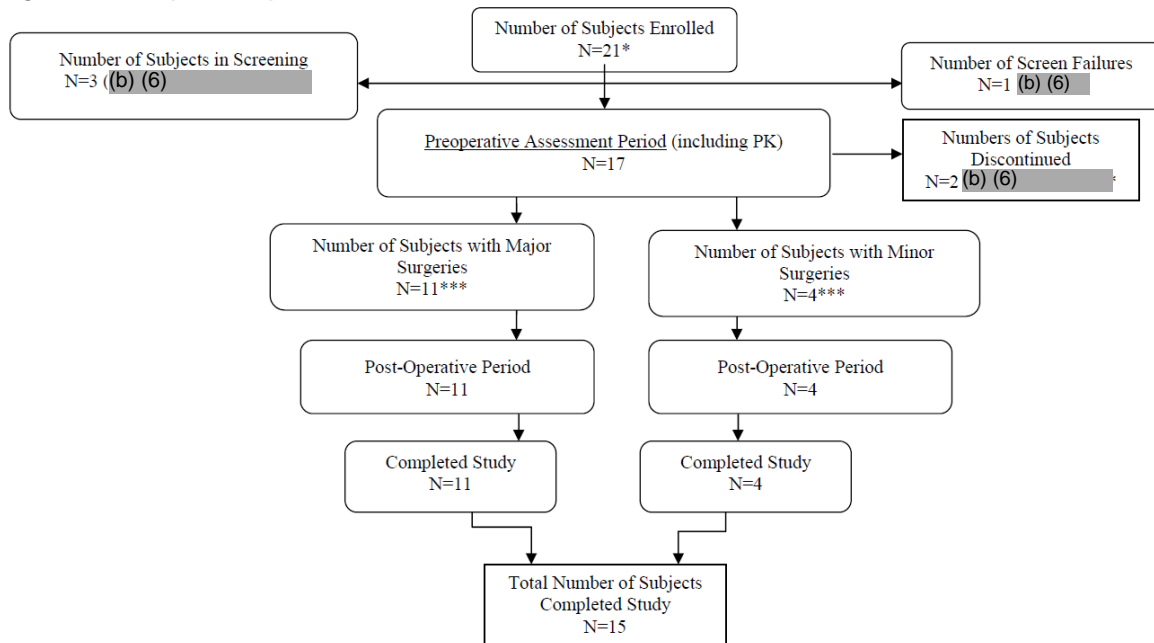

\* Number of unique subjects enrolled = 19.  
 \*\* Number of unique subjects discontinued = 1; Subjects (b) (6) are the same subject.  
 \*\*\* Each subject had one procedure.

Source: BLA 125566/51 CSR 261204 Source: Figure 10.1.1-1 pg 45/140

**Protocol Deviations:**

Eighty-seven deviations were reported in 14 subjects. Most were minor (93.1%). Six deviations were major and included two deviations in the “eligibility” category and four in the “protocol schedule” category. The four deviations included one subject who did not meet the inclusion criteria of a FVIII activity of less than 1%, but had a history of a documented level of <1%. The same subject did not have a washout period of 72 hours, and the shorter washout period could have resulted in the higher FVIII level. One subject was in another clinical trial and deviated from the criterion that at least 30 days must have elapsed prior to enrolling in another study. The subject started on ADYNOVATE 17 days after the last dose in the previous study. Surgery had been performed in this study without any AEs. Two subjects had blood tests for immunogenicity drawn too soon. For one subject, the time between the PK assessment and the day of surgery was outside the protocol- specified window, as the subject had surgery performed 68 days after the PK assessment.

**Reviewer Comment:**

*Of the four major deviations, these subjects’ deviations would not have affected the study outcomes. The impact of these is very low.*

**6.2.11 Efficacy Analyses**

Fifteen subjects underwent surgical procedures. Two subjects had discontinued the study prior to the surgery. All subjects were male and between 19 and 52 years of age at the time of enrollment. One subject was enrolled twice and one subject was withdrawn. One subject was Asian, and the rest were White. All subjects except one had a history of hemophilic arthropathy.

### 6.2.11.1 Analyses of Primary Endpoint(s)

The intraoperative efficacy of ADYNOVATE to provide hemostatic control was rated by the operating surgeon as “excellent” for all 15 procedures. The perioperative efficacy which was assessed at discharge or Day 14 was rated as “excellent” for all 15 procedures. The postoperative efficacy of ADYNOVATE, as assessed by the operating surgeon on postoperative Day 1 was rated as “excellent” for 13 procedures. One minor surgery was rated as “good” and another minor surgery was not rated at the time of data cut-off for this report.

Table 10: Efficacy Score for Surgery

**Primary Outcome Measure: Descriptive Statistics of Global Hemostatic Efficacy Assessment Score (GHEA)  
(Bax 855 Surgery 261204: Full Analysis Set)**

Assessment	Intraoperative <sup>a</sup> (Operating Surgeon's Assessment)			Postoperative <sup>b</sup> (Operating Surgeon's Assessment)			Perioperative <sup>c</sup> (Operating Surgeon's Assessment)		
	Type of Surgery			Type of Surgery			Type of Surgery		
	Major N = 11 n(% <sup>d</sup> )	Minor N = 4 n(% <sup>e</sup> )	All N = 15 n(% <sup>f</sup> )	Major N = 11 n(% <sup>d</sup> )	Minor N = 4 n(% <sup>e</sup> )	All N = 15 n(% <sup>f</sup> )	Major N = 11 n(% <sup>d</sup> )	Minor N = 4 n(% <sup>e</sup> )	All N = 15 n(% <sup>f</sup> )
Excellent	11 (100.0)	4 (100.0)	15 (100.0)	11 (100.0)	2 (50.0)	13 (86.7)	11 (100.0)	4 (100.0)	15 (100.0)
Good	0 (0.0)	0 (0.0)	0 (0.0)	0 (0.0)	1 (25.0)	1 (6.7)	0 (0.0)	0 (0.0)	0 (0.0)
Fair	0 (0.0)	0 (0.0)	0 (0.0)	0 (0.0)	0 (0.0)	0 (0.0)	0 (0.0)	0 (0.0)	0 (0.0)
None	0 (0.0)	0 (0.0)	0 (0.0)	0 (0.0)	0 (0.0)	0 (0.0)	0 (0.0)	0 (0.0)	0 (0.0)
Not Done	0 (0.0)	0 (0.0)	0 (0.0)	0 (0.0)	1 (25.0)	1 (6.7)	0 (0.0)	0 (0.0)	0 (0.0)
Total	11 (100.0)	4 (100.0)	15 (100.0)	11 (100.0)	4 (100.0)	15 (100.0)	11 (100.0)	4 (100.0)	15 (100.0)

<sup>a</sup>Assessment of intraoperative hemostatic efficacy of BAX 855.

<sup>b</sup>Assessment of postoperative hemostatic efficacy of BAX 855 at postoperative Day 1 (ie, the day following the day of surgery).

<sup>c</sup>Assessment of perioperative hemostatic efficacy of BAX 855 at discharge or Day 14, whichever is first.

<sup>d</sup>Percentage are computed based on the total number of assessments scores within major surgeries.

<sup>e</sup>Percentage are computed based on the total number of assessments scores within minor surgeries.

<sup>f</sup>Percentage are computed based on the total number of assessments scores of all surgeries.

Source: BLA 125566/51 CSR 261204 Source: Table 7 pg 85/140

The minor procedures included a dental and dermatologic procedure. The minor dental procedure that was rated as “good” had an intraoperative blood loss of 5 mL. The subject had oozing of blood from the gums post-operatively. Six days after the procedure, the subject had a small bleed and treated with Amicar and ADYNOVATE. No recurrent bleeding occurred after that.

*Reviewer Comment: The treatment for the minor bleeding is appropriate.*

For major surgeries, the median (Q1; Q3) overall perioperative blood loss was 50 mL (7; 1000). The median maximum perioperative blood loss was estimated to be 150 mL (20; 1500). Three subjects had an overall perioperative blood loss in the range of 1210 to 1430 mL, greater than the average of 1000 mL but less than the 1500 mL of blood loss.

### 6.2.11.2 Analyses of Secondary Endpoints

To determine intra- and post-operative blood loss, volume of blood, red blood cells, platelets, and other blood products transfused, the occurrence of bleeding episodes and additional need for surgical intervention, and daily and total weight-adjusted consumption of ADYNOVATE per subject were the secondary endpoints.

With a median (quartile 1 [Q1]; quartile 3 [Q3]) observed blood loss of 10.0 (5.0; 50.0) mL for major surgeries and 2.5 (0.0; 27.5) mL for minor surgeries, the actual



intraoperative blood loss was considerably lower than the predicted average (median) of 50.0 (6.0;150) mL for major surgeries and 2.5 (0.0; 102.5) mL for minor surgeries. Postoperative blood loss was observed in five major surgeries. Daily blood loss until postoperative Day 5 occurred in one subject who had knee replacement surgery; blood loss on postoperative Days 1, 2, and 4 occurred in one major abdominal surgery; blood loss on postoperative Days 1 and 2 occurred in two knee replacement surgeries; and blood loss on postoperative Day 1 occurred in one arthroscopic synovectomy. The median blood loss observed in major surgeries on postoperative Day 1 was 65 mL, which was higher than the median maximum blood loss of 50 mL, predicted by the surgeons preoperatively for the types of procedures. This was less than the estimated maximum postoperative blood loss of 1200 mL.

Three subjects had postoperative bleeding episodes occurred that were injury-related and not at the surgical location. Two subjects received blood transfusions.

Of 15 subjects who underwent surgery, four subjects with major surgery had bleeding episodes. Three subjects experienced one bleeding episode each; one subject experienced three bleeding episodes. None of these were at the surgical site.

*Reviewer Comment: The subject who had a knee replacement and postoperative blood loss for five days was assessed as an excellent rating. It may seem questionable whether blood loss for five days should be assessed as excellent, but this assessment is judged as appropriate due to the type of orthopedic surgery where the estimated blood loss can approach two liters. In this case, the overall blood loss was over one liter and the subject received a transfusion. One subject with major abdominal surgery experienced bleeding one day after surgery. This bleeding was not located at the surgical site, but did receive two transfusions for low hemoglobin.*

There were 230 ADYNOVATE infusions administered. Of these, 16 were PK infusions, 136 were administered for major surgery (11 subjects), nine for minor surgery (four subjects), nine for bleeding episodes (two subjects who underwent major surgery), and 60 for prophylactic infusions (seven subjects who underwent major surgery). One subject received 31 of the 60 prophylactic infusions.

For all surgeries (n=15), the mean  $\pm$ SD planned daily weight-adjusted dose was 35.7  $\pm$ 17.14 IU/kg (range: 9.1-100 IU/kg). The mean  $\pm$ SD actual daily weight-adjusted dose administered per subject (including PK infusions, prophylactic infusions and infusions administered for bleeding episodes) was similar: 34.9  $\pm$ 16.7 IU/kg (range: 9.1-99.2 IU/kg).

For major surgeries (n=11), the mean  $\pm$  SD planned daily weight-adjusted dose was 35.09  $\pm$ 17.076 IU/kg (median: 30.7 IU/kg, range: 9.1-100 IU/kg). For minor surgeries (n=4), the mean  $\pm$ SD planned daily weight-adjusted dose was 44.7  $\pm$ 16.4 IU/kg (median: 41.1 IU/kg, range: 20.8-69.3 IU/kg).

Fourteen subjects (13 unique subjects) received a PK infusion in this study. Two subjects had their PK infusion and assessment performed in the adult study. The PK infusion was administered at a dose of 60 $\pm$ 5 IU/kg. Terminal half-life ranged from 8.8 to 18.1 hours. In nine subjects, a half-life >14 hours was calculated. In the remaining six subjects, half-life ranged from 8.8 to 13.6 hours. A half-life <10 hours was only calculated for one subject

#### 6.2.11.3 Subpopulation Analyses

N/A

#### 6.2.11.4 Dropouts and/or Discontinuations

Four of the 21 subjects enrolled did not receive the study drug.

#### 6.2.11.5 Exploratory and Post Hoc Analyses

N/A

#### 6.2.12 Safety Analyses

##### 6.2.12.1 Methods

A safety review was planned once 10 major surgeries had been completed. The analysis was to include all major and minor surgeries performed until that time. The report submitted with this efficacy supplement contains the 11 major and 4 minor surgeries evaluated.

##### 6.2.12.2 Overview of Adverse Events

Fourteen AEs were reported for five subjects. Six AEs were of moderate severity, four were considered severe and four as mild. All AEs were considered by the investigators to be unrelated to the study drug, except one. This AE was an increase in ALT on postoperative Days 4-6 following orthopedic surgery. This was considered by the investigator to be related by the study drug but unrelated by the sponsor.

*Reviewer Comment: The respective ALT results were 48, 52, and 49 IU/L with a reference range of 6-43 IU/L. The ALT results on postoperative Day 2 and 7 were within normal range. This transient elevation of transaminases is judged to be not related. There was no other relevant history given to attribute this AE to another cause.*

None of the subjects developed inhibitory antibodies to FVIII. One subject had positive IgG binding antibody to FVIII at the termination visit, which was negative at screening. The same subject had a preexisting IgG binding antibody to PEG-FVIII at screening and at the completion/termination visit which did not increase during the study. There were no positive results of IgG binding antibody to PEG. None of the subjects developed binding antibodies to CHO proteins. There were no thrombotic events or related AEs considered allergic reactions by the investigators.

##### 6.2.12.3 Deaths

There were no deaths.

##### 6.2.12.4 Nonfatal Serious Adverse Events

Four SAEs occurred in one subject and was later discontinued from the study after the PK assessment and had no surgery. This subject was enrolled twice and had an esophageal ulcer and three episodes of diabetic gastroparesis.

##### 6.2.12.5 Adverse Events of Special Interest (AESI)

N/A

#### 6.2.12.6 Clinical Test Results

Laboratory results showed that less than 10% of the subjects had shifts from high/normal values to values below the lower limit of normal. No trends over time were observed for clinical chemistry parameters and hematology parameters.

#### 6.2.12.7 Dropouts and/or Discontinuations

One subject was enrolled twice and then withdrawn after the pre-surgical PK infusion due to AEs.

*Reviewer Comment: This subject had three events of diabetic gastroparesis and one esophageal ulcer. This event is evaluated to be not related to the study drug. Please refer to Section 6.2.12.*

#### 6.2.13 Study Summary and Conclusions

ADYNOVATE was safe and well tolerated for perioperative management in 11 major and 4 minor surgeries. No deaths and no related SAEs occurred. There were no AEs considered thrombotic events or related AEs considered allergic reactions by the investigator. None of the subjects developed inhibitory antibodies to FVIII. None of the subjects developed IgM binding antibodies, and there were no persistent IgG binding antibodies to FVIII, PEG-FVIII, and PEG. None of the subjects developed binding antibodies to CHO proteins.

ADYNOVATE was used in the perioperative management in 11 major surgeries in 15 subjects. Efficacy was rated as excellent, as the blood loss was less than or equal to the expected for the same type of procedure in a non-hemophilic population. Intraoperative hemostatic efficacy was also rated as excellent for all 15 procedures. Postoperative blood loss was observed in five major surgeries, but the maximum postoperative blood loss was not exceeded. There were three subjects with perioperative bleeding of over a liter but did not exceed the predicted perioperative blood loss of 1500 mL. Overall, ADYNOVATE showed efficacy for perioperative use in major surgery.

## 7. INTEGRATED OVERVIEW OF EFFICACY

### 7.1 Indication #1

N/A

#### 7.1.1 Methods of Integration

N/A

#### 7.1.2 Demographics and Baseline Characteristics

N/A

#### 7.1.3 Subject Disposition

N/A

#### 7.1.4 Analysis of Primary Endpoint(s)

N/A

7.1.5 Analysis of Secondary Endpoint(s)

N/A

7.1.6 Other Endpoints

N/A

7.1.7 Subpopulations

N/A

7.1.8 Persistence of Efficacy

N/A

7.1.9 Product-Product Interactions

N/A

7.1.10 Additional Efficacy Issues/Analyses

N/A

7.1.11 Efficacy Conclusions

N/A

**7.2 Indication #2**

N/A

7.2.1 Methods of Integration

N/A

7.2.2 Demographics and Baseline Characteristics

N/A

7.2.3 Subject Disposition

N/A

7.2.4 Analysis of Primary Endpoint(s)

N/A

7.2.5 Analysis of Secondary Endpoint(s)

N/A

7.2.6 Other Endpoints

N/A

7.2.7 Subpopulations

N/A

7.2.8 Persistence of Efficacy

N/A

7.2.9 Product-Product Interactions

N/A

7.2.10 Additional Efficacy Issues/Analyses

N/A

7.2.11 Efficacy Conclusions

N/A

8. INTEGRATED OVERVIEW OF SAFETY

**8.1 Safety Assessment Methods**

N/A

**8.2 Safety Database**

8.2.1 Studies/Clinical Trials Used to Evaluate Safety

a) phase 3 prospective uncontrolled multicenter pediatric study to evaluate the PK, efficacy, safety and immunogenicity of ADYNOVATE in 66 pediatric subjects (<12 years of age) to support routine prophylaxis (Study # 261202) and b) data from a phase 3 multicenter, open-label study of the efficacy and safety of ADYNOVATE in previously treated patients (PTPs) with severe hemophilia A undergoing surgical or other invasive procedures to support perioperative management (Study # 261204).

8.2.2 Overall Exposure, Demographics of Pooled Safety Populations

N/A

8.2.3 Categorization of Adverse Events

N/A

**8.3 Caveats Introduced by Pooling of Data Across Studies/Clinical Trials**

N/A

**8.4 Safety Results**

8.4.1 Deaths

There were no deaths.

8.4.2 Nonfatal Serious Adverse Events

N/A

8.4.3 Study Dropouts/Discontinuations

N/A

8.4.4 Common Adverse Events

N/A

8.4.5 Clinical Test Results

N/A

8.4.6 Systemic Adverse Events

N/A

8.4.7 Local Reactogenicity

N/A

8.4.8 Adverse Events of Special Interest

N/A

**8.5 Additional Safety Evaluations**

8.5.1 Dose Dependency for Adverse Events

N/A

8.5.2 Time Dependency for Adverse Events

N/A

8.5.3 Product-Demographic Interactions

N/A

8.5.4 Product-Disease Interactions

N/A

8.5.5 Product-Product Interactions

N/A

8.5.6 Human Carcinogenicity

N/A

8.5.7 Overdose, Drug Abuse Potential, Withdrawal, and Rebound

N/A

8.5.8 Immunogenicity (Safety)

No subject developed an inhibitory antibody to FVIII. No subject in this supplement developed IgG or IgM antibodies against PEG, PEG-FVIII, and CHO protein.

8.5.9 Person-to-Person Transmission, Shedding  
N/A

## 8.6 Safety Conclusions

No subject developed an inhibitory antibody to FVIII. No subject in this supplement developed IgG or IgM antibodies against PEG, PEG-FVIII, and CHO protein.

## 9. ADDITIONAL CLINICAL ISSUES

### 9.1 Special Populations

N/A

#### 9.1.1 Human Reproduction and Pregnancy Data

N/A

#### 9.1.2 Use During Lactation

N/A

#### 9.1.3 Pediatric Use and PREA Considerations

This supplement was presented to the Pediatric Review Committee (PeRC) on October 19, 2016. The PeRC concurred that the product has been fully assessed in patients 1 year to <18 years.

Please also refer to Sections 11.3 Discussion of Regulatory Options and 11.6 Recommendations on Postmarketing Actions below.

#### 9.1.4 Immunocompromised Patients

N/A

#### 9.1.5 Geriatric Use

N/A

### 9.2 Aspect(s) of the Clinical Evaluation Not Previously Covered

After submission of the interim report, 11 additional surgeries (one minor and 10 major) were conducted and were reported to be rated as "excellent." This report was included Amendment 51.9 and 51.12. The last subject was screened and scheduled for major surgery in September 2016. The final CSR is to be completed in the first quarter of 2017 and then data will be reviewed when submitted.

## 10. CONCLUSIONS

Overall, the completed pediatric study continued to show overall efficacy and safety of ADYNOVATE in subjects <12 years and in the perioperative study. There were no reports of hypersensitivity or vascular thrombotic events, nor any clusters of adverse events identified. The additional data from the adult and pediatric subjects continue to show low ABR and are in line with the parent studies. The interim report of the surgery study also continues to show efficacy in this cohort of subjects.

## 11. RISK-BENEFIT CONSIDERATIONS AND RECOMMENDATIONS

### 11.1 Risk-Benefit Considerations

Please see Table 11 below:



Table 11: Risk Benefit Table

Decision Factor	Evidence and Uncertainties	Conclusions and Reasons
<b>Analysis of Condition</b>	<ul style="list-style-type: none"> <li>Hemophilia A is a hereditary bleeding disorder characterized by recurrent bleeding, which if left untreated bleeds lead to chronic arthropathy, muscular atrophy and deformities.</li> <li>Treatment of bleeds may delay these complications, but does not prevent it.</li> <li>Primary prophylaxis with regular FVIII injections initiated at an early age is becoming the standard of care</li> </ul>	<ul style="list-style-type: none"> <li>Hemophilia A is a hereditary, life-threatening disease</li> <li>Hemophilia A can have a debilitating impact on physical and psychosocial well-being.</li> </ul>
<b>Unmet Medical Need</b>	<ul style="list-style-type: none"> <li>Numerous other plasma-derived factor VIII products also exist, but carry the same risks as other human plasma products, such as infection with known or future agents, acute hypersensitivity reactions, or immunogenicity with resistance to therapy.</li> </ul>	<ul style="list-style-type: none"> <li>None</li> </ul>
<b>Clinical Benefit</b>	<ul style="list-style-type: none"> <li>The benefit of this product derives from its ability to replace the deficient FVIII. The benefits of FVIII replacement include prevention of bleeding. This supplement demonstrated efficacy for bleeding prevention using within subjects comparisons of periods using an on demand regimen and periods using routine prophylaxis. The observed reduction in the annualized spontaneous bleeding rate indicates an effective capacity to provide this benefit.</li> </ul>	<ul style="list-style-type: none"> <li>The clinical evidence is adequate based on the results of all clinical studies.</li> <li>A second benefit is the product's ability to control bleeding and to prevent recurrence of bleeding at the initial site of injury.</li> <li>ADYNOVATE has clinical benefit for the perioperative treatment of both major and minor surgeries</li> </ul>
<b>Risk</b>	<ul style="list-style-type: none"> <li>The principal identified risks of hemophilia products are development of inhibitors, hypersensitivity reactions, and thromboembolic events. None of these events occurred in the clinical trials populations. An important limitation of the available data is that the group with the greatest risk for inhibitor development and hypersensitivity reactions, previously untreated patients, has yet to be studied.</li> </ul>	<ul style="list-style-type: none"> <li>ADYNOVATE was well tolerated with no major risks of inhibitor development, hypersensitivity reaction or thromboembolic events. An important limitation of the available data is that the group with the greatest risk for inhibitor development and hypersensitivity reactions, previously untreated patients, has yet to be studied.</li> </ul>
<b>Risk Management</b>	<ul style="list-style-type: none"> <li>This supplement fulfills two Pediatric PMR studies. The PUP study is ongoing.</li> </ul>	<ul style="list-style-type: none"> <li>The package insert and the current routine pharmacovigilance plan, including postmarketing studies in PUPs are adequate to manage the risks. There should be continued routine postmarketing pharmacovigilance.</li> </ul>

### **11.2 Risk-Benefit Summary and Assessment**

The formation of FVIII inhibitors was not observed in the studies in this supplement. None of the subjects showed allergic symptoms or decreased therapeutic effect. No hypersensitivity or thrombotic events were observed.

Due to the effective hemostasis in treatment and control of bleeding episodes and routine prophylaxis in children <12 years with hemophilia A and effectiveness in perioperative management, the benefits of ADYNOVATE are considered to outweigh the risks. Although ADYNOVATE has a somewhat longer half-life (1.4-1.5x) than non-fusion protein marketed rFVIII products, the extent of the practical advantage of this product has yet to be determined given that some of the currently licensed recombinant FVIII, including ADVATE, can also be dosed twice weekly for prophylaxis.

### **11.3 Discussion of Regulatory Options**

The available data support approval of the indications of on-demand treatment and control of bleeding episodes and routine prophylaxis in children (<12 years) with hemophilia A and perioperative management. This approval would fulfill the first two PREA PMRs (See Section 11.6 below), although FDA would require the Final study Report to be submitted for PMR #2.

### **11.4 Recommendations on Regulatory Actions**

I recommend approval of this efficacy supplement. Completion of all postmarketing studies is recommended.

### **11.5 Labeling Review and Recommendations**

A labeling review and negotiations with Baxter have been completed, resulting in several changes to the originally proposed draft package insert.

### **11.6 Recommendations on Postmarketing Actions**

As per the original BLA, the applicant has the following PMC/PMRs:

PMRs:

1) Deferred pediatric study under PREA for the on-demand treatment and control of bleeding episodes and routine prophylaxis to reduce the frequency of bleeding episodes in pediatric patients ages 0 to <12 years (A phase 3 prospective, uncontrolled, multi-center study to evaluate PK, efficacy, safety, and immunogenicity of ADYNOVATE in pediatric previously treated patients (PTPs) less than 12 years of age [clinical study 261202]).

2) Deferred pediatric study under PREA for the treatment of perioperative management of bleeding in pediatric patients ages two years to less than 17 years (A phase 3, prospective, open label, multi-center study of efficacy and safety of ADYNOVATE in the perioperative management of bleeding in PTPs age 2-75 years [clinical study 261204] – **PEDIATRIC COMPONENT ONLY**).

3) Deferred pediatric study under PREA for routine prophylaxis to compare the efficacy and safety of two different pharmacokinetics (PK) guided dosing regimens in pediatric patients ages 12 to < 17 years (A phase 3, prospective, randomized, multi-center clinical study comparing the safety and efficacy of ADYNOVATE following PK-guided prophylaxis targeting two different FVIII trough levels in subjects with severe Hemophilia A [clinical study 261303] - **PEDIATRIC COMPONENT ONLY**).

PMCs:

1) "A phase 3, prospective, open label, multi-center study of efficacy and safety of ADYNOVATE in the perioperative management of bleeding in PTPs age 2-75 years" [clinical study 261204] – **ADULT COMPONENT ONLY**.

2) "A phase 3b, prospective, open label, and multi-center continuation study of safety and efficacy of ADYNOVATE in the routine prophylaxis of bleeding to reduce the frequency of bleeding episodes in PTPs" age 12 years and above [clinical study 261302].

3) "A phase 3, prospective, randomized, multi-center clinical study comparing the safety and efficacy of BAX 855 [ADYNOVATE] following PK-guided prophylaxis targeting two different FVIII trough levels in subjects with severe Hemophilia A" [clinical study 261303] – **ADULT COMPONENT ONLY**.

4) "A phase 3, multi-center, open label study to investigate safety and immunogenicity of ADYNOVATE in previously untreated patients (PUPs)" [clinical study 261203]. This study will evaluate on-demand treatment and control of bleeding episodes in the setting of routine prophylaxis to reduce the frequency of bleeding episodes, as well as the perioperative management of bleeding.

GHEA SCORING

Appendix 1:  
GHEA scoring

<b>Table 1.</b> <b>Global Hemostatic Efficacy Assessment (GHEA)</b>	
<b>Assessment</b>	<b>GHEA Score</b>
Excellent	7 <sup>a</sup> to 9 (with no category scored < 2)
Good	5 to 7 <sup>a</sup> (with no category scored < 1)
Fair	3 to 4 (with no category scored < 1)
None	0 to 2 (or at least one category scored 0)

<sup>a</sup>. For a GHEA score of 7 to be rated “excellent” (with no individual assessment scores less than 2), at least 1 individual assessment score must be 3 and the other 2 individual assessment scores must be at least 2; otherwise a score of 7 is rated “good”.

<b>Table 2.</b> <b>Intraoperative Efficacy Assessment Scale</b>		
<b>A</b>	<i>At the time of discharge from the OR, the operating surgeon will assess the intraoperative hemostatic efficacy</i>	
<b>Rating</b>	<b>Criteria</b>	<b>Score</b>
Excellent	Intraoperative blood loss was less than or equal to that expected for the type of procedure performed in a non-hemophilic population ( $\leq 100\%$ )	3
Good	Intraoperative blood loss was up to 50% more than expected for the type of procedure performed in a non-hemophilic population (101-150%)	2
Fair	Intraoperative blood loss was more than 50% of that expected for the type of procedure performed in a non-hemophilic population ( $>150\%$ )	1
None	Uncontrolled hemorrhage that was the result of inadequate therapeutic response despite proper dosing, necessitating rescue therapy	0

<b>Table 3.</b> <b>Postoperative Efficacy Assessment Scale (Postoperative Day 1)</b>		
<b>B</b>	<i>On postoperative Day 1, the operating surgeon will assess the postoperative hemostatic efficacy by the operating surgeon</i>	
<b>Rating</b>	<b>Criteria</b>	<b>Score</b>
Excellent	Postoperative blood loss was less than or equal to ( $\leq 100\%$ ) that expected for the type of procedure performed in a non-hemophilic population	3
Good	Postoperative blood loss was up to 50% more (101-150%) than expected for the type of procedure performed in a non-hemophilic population	2
Fair	Postoperative blood loss was more than 50% ( $>150\%$ ) of that expected for the type of procedure performed in a non-hemophilic population	1
None	Significant postoperative bleeding that was the result of inadequate therapeutic response despite proper dosing, necessitating rescue therapy	0

<b>Table 4.</b> <b>Perioperative Efficacy Assessment Scale (Discharge Visit or Day 14, whichever is first)</b>		
<b>C</b>	<i>At the discharge Visit or Day 14, whichever is first, a hematologist will assess the perioperative efficacy</i>	
<b>Rating</b>	<b>Criteria</b>	<b>Score</b>
Excellent	Perioperative blood loss was less than or equal to ( $\leq 100\%$ ) that expected for the type of procedure performed in a non-hemophilic population, Required blood components for transfusions were less than or similar to that expected in non-hemophilic population	3
Good	Perioperative blood loss was up to 50% more (101-150%) than expected for the type of procedure performed in a non-hemophilic population Required blood components for transfusions were less than or similar to that expected in non-hemophilic population	2
Fair	Perioperative blood loss was more than 50% of that expected for the type of procedure performed in a non-hemophilic population ( $>150\%$ ) Required blood components transfusions were greater than that expected in non-hemophilic population	1
None	Significant perioperative bleeding that was the result of inadequate therapeutic response despite proper dosing, necessitating rescue therapy Required blood components for transfusions were substantially greater than that expected in non-hemophilic population	0

Source: Study Protocol Amendment 3 version 2014 Jan 30; page 27, 28

**\*\*\*Do Not Change Anything Below This Line\*\*\***