

530 Du/DuN Operating Manual

Contents

1 Declaration of conformity	4
2 Declaration of incorporation	5
3 When you unpack your pump	6
3.1 Unpacking your pump	6
3.2 Packaging disposal	6
3.3 Inspection	6
3.4 Components supplied	6
3.5 Storage	6
4 Information for returning pumps	7
5 Peristaltic pumps - an overview	8
6 Warranty	9
7 Safety notes	10
8 Pump specifications	13
8.1 Specification ratings	13
8.2 Weights	13
8.3 Pumphead options	14
9 Good pump installation practice	15
9.1 General recommendations	15
9.2 Dos and don'ts	16
10 Pump operation	17
10.1 Keypad Layout and Key IDs	17
10.2 Starting and stopping	18
10.3 Using up and down keys	18
10.4 Maximum speed	18
10.5 Change rotation direction	18
11 Connecting to a power supply	19
11.1 Conductor colour coding	20
12 Start-up check list	21
13 Control wiring	22
13.1 Upper D-connector	22
13.2 Lower D-connector	22

13.3 Standard - 25 way D: Inputs and Outputs	23
13.4 Standard - 25 way D: power supply limits	30
13.5 N - Modules Standard and SCADA	30
13.6 Standard N - Module	31
13.7 SCADA N-Module	35
13.8 Standard - 9 way D - RS232 Use	37
14 Switching the pump on for the first time	41
14.1 Selecting the display language	41
14.2 First-time start-up defaults	42
15 Switching the pump on in subsequent power cycles	44
16 Mode menu	45
17 Manual	46
17.1 START	46
17.2 STOP	47
17.3 INCREASING AND DECREASING FLOW RATE	47
17.4 MAX FUNCTION (Manual mode only)	48
18 Flow calibration	49
18.1 Setting the flow calibration	49
19 Analog mode	52
19.1 Analog calibration	53
19.2 Calibrate Input 1	54
19.3 Setting a high signal	55
19.4 Setting high flow calibration	57
19.5 Setting a low signal	57
19.6 Setting low flow calibration	59
19.7 Calibrating the scaling input	60
19.8 Setting a high signal	62
19.9 Setting high flow calibration	63
19.10 Setting a low signal	63
19.11 Setting low flow calibration	64
20 Network mode	66
20.1 Network settings	66
20.2 Protocol	67
20.3 Pump No	67
20.4 Baud rate	67
20.5 Stop bits	67
20.6 Save network settings	68

21 MemoDose mode	69
21.1 To configure MemoDose	69
21.2 Set flow rate	70
21.3 Resume interrupted doses	71
21.4 Master dose	72
21.5 Manual dosing	76
22 Main menu	77
22.1 Security settings	78
22.2 General settings	87
22.3 Control settings	98
22.4 Configure outputs	99
22.5 Configure inputs	101
22.6 Help	102
23 Troubleshooting	103
23.1 Leak detection	103
23.2 Error codes	104
23.3 Technical support	105
24 Drive maintenance	106
25 Drive spares	107
26 Pumphead replacement	108
26.1 Pumphead replacement	108
27 Tube replacement	109
27.1 Continuous tubing	109
27.2 Tube elements	110
28 Ordering information	112
28.1 Pump part numbers	112
28.2 Tubing and element part numbers	113
28.3 Pumphead spares	117
28.4 Pumping accessories	119
29 Performance data	121
29.1 Performance curves	121
30 Trademarks	126
31 Disclaimers	127
32 Publication history	128

1 Declaration of conformity



Watson-Marlow Ltd
Falmouth
Cornwall
TR11 4RU
England



EC Declaration of Conformity

Description	530 cased pumps
Models	S, SN, U, UN, Du, DuN, Bp, BpN
Conformity	Watson-Marlow Ltd declares that when this pump unit is used as a stand-alone pump it complies with Machinery Directive 2006/42/EC.
Standards	<p>Watson-Marlow Ltd declares that the above stated products are in conformance with the following harmonised standards and directives:</p> <p>Safety of Machinery-Electrical equipment of machines; BS EN 60204-1 Safety requirements for electrical equipment for measurement, control and laboratory use; BS EN 61010-1 UL 61010-1 Safety of machinery-Basic concepts, general principals of design BS EN ISO 12100-1 and BS EN ISO 12100-2 Degrees of protection provided by enclosures (IP code) BS EN 60529 Electro-Magnetic Compatibility Directive 2014/30/EU Electrical equipment for measurement, control and laboratory use. EMC requirements, general requirements; BS EN 61326-1 Low Voltage Directive 2006/95/EC</p>
Manufacturer	Watson-Marlow Ltd, TR11 4RU, England
Date	31.07.2015
Signature	 Simon Nicholson, Managing Director, Watson-Marlow Ltd

2 Declaration of incorporation



Watson-Marlow Ltd
Falmouth
Cornwall
TR11 4RU
England

Declaration of Incorporation

In accordance with the Machinery Directive 2006/42/EC that if this unit is to be installed into a machine or is to be assembled with other machines for installations, it shall not be put into service until the relevant machinery has been declared in conformity.

We hereby declare that:

Peristaltic Pump

Series: 530 cased pumps

the following harmonised standards have been applied and fulfilled for health and safety requirements:

Safety of Machinery – EN ISO 12100

Safety of Machinery – Electrical Equipment of Machines BS EN 60204-1

Quality Management System – ISO 9001

and the technical documentation is compiled in accordance with Annex VII(B) of the Directive.

We undertake to transmit, in response to a reasoned request by the appropriate national authorities, relevant information on the partly completed machinery identified above. The method of transmission shall be by mail or email.

The pump head is incomplete and must not be put into service until the machinery into which it is to be incorporated has been declared in conformity with the provisions of the Directive.

Person authorised to compile the technical documents:

A handwritten signature in black ink, appearing to read 'A. Green'.

Andrew Green, Design & Engineering Director, Watson-Marlow Ltd.

Place and date of declaration: Watson-Marlow Ltd, 31.07.2015

Responsible person:

A handwritten signature in black ink, appearing to read 'S. Nicholson'.

Simon Nicholson, Managing Director, Watson-Marlow Ltd

3 When you unpack your pump

3.1 Unpacking your pump

Unpack all parts carefully, retaining the packaging until you are sure all components are present and in good order. Check against the components supplied list, below.

3.2 Packaging disposal

Dispose of packaging materials safely, and in accordance with regulations in your area. The outer carton is made of corrugated cardboard and can be recycled.

3.3 Inspection

Check that all components are present. Inspect components for damage in transit. If anything is missing or damaged, contact your distributor immediately.

3.4 Components supplied

530 Components

- 530 pump drive unit, fitted with 520R2 or other pumphead if specified as a pump
- The designated power cable (attached to the pump drive unit)
- A 520N module providing pump ingress protection to IP66, NEMA 4X, if a 530SN, 530UN, 530DuN or 530BpN.

Note: the module is attached for transit, but must be removed to allow wiring up, voltage selection and fuse inspection and then re-affixed before the pump is operated.

- Product safety information booklet incorporating quick start manual

3.5 Storage

This product has an extended shelf life. However, care should be taken after storage to ensure that all parts function correctly. Please observe the storage recommendations and use-by dates which apply to tubing you may wish to bring into service after storage.

4 Information for returning pumps

In compliance with the UK Health and Safety at Work Act and the Control of Substances Hazardous to Health Regulations, you are required to declare the substances which have been in contact with product(s) you return to Watson-Marlow or its subsidiaries or distributors. Failure to do so will cause delays. Please ensure that you email us this information and receive a RGA (Returned Goods Authorisation) before you despatch the product(s). A copy of the RGA form must be attached to the outside of the packaging containing the product(s).

Please complete a separate decontamination certificate for each product and attach it to the outside of the packaging containing the product(s). A copy of the appropriate decontamination certificate can be downloaded from the Watson-Marlow website at www.wmftg.com

You are responsible for cleaning and decontaminating the product(s) before return.

5 Peristaltic pumps - an overview

Peristaltic pumps are the simplest possible pump, with no valves, seals or glands to clog or corrode. The fluid contacts only the bore of a tube, eliminating the risk of the pump contaminating the fluid, or the fluid contaminating the pump. Peristaltic pumps can operate dry without risk.

How they work

A compressible tube is squeezed between a roller and a track on an arc of a circle, creating a seal at the point of contact. As the roller advances along the tube, the seal also advances. After the roller has passed, the tube returns to its original shape, creating a partial vacuum which is filled by fluid drawn from the inlet port.

Before the roller reaches the end of the track, a second roller compresses the tube at the start of the track, isolating a packet of fluid between the compression points. As the first roller leaves the track, the second continues to advance, expelling the packet of fluid through the pump's discharge port. At the same time, a new partial vacuum is created behind the second roller into which more fluid is drawn from the inlet port.

Backflow and siphoning do not occur, and the pump effectively seals the tube when it is inactive. No valves are needed.

The principle may be demonstrated by squeezing a soft tube between thumb and finger and sliding it along: fluid is expelled from one end of the tube while more is drawn in at the other.

Animal digestive tracts function in a similar way.

Suitable applications

Peristaltic pumping is ideal for most fluids, including viscous, shear-sensitive, corrosive and abrasive fluids, and those containing suspended solids. They are especially useful for pumping operations where hygiene is important.

Peristaltic pumps operate on the positive displacement principle. They are particularly suitable for metering, dosing and dispensing applications. Pumps are easy to install, simple to operate and inexpensive to maintain.

6 Warranty

Watson-Marlow Ltd ("Watson-Marlow") warrants this product to be free from defects in materials and workmanship for five years from the date of shipment, under normal use and service.

Watson-Marlow's sole responsibility and the customer's exclusive remedy for any claim arising out of the purchase of any product from Watson-Marlow is, at Watson-Marlow's option: repair, replacement or credit, where applicable.

Unless otherwise agreed in writing, the foregoing warranty is limited to the country in which the product is sold.

No employee, agent or representative of Watson-Marlow has the authority to bind Watson-Marlow to any warranty other than the foregoing unless in writing and signed by a director of Watson-Marlow. Watson-Marlow makes no warranty of the fitness of its products for a particular purpose.

In no event:

- i. shall the cost of the customer's exclusive remedy exceed the purchase price of the product;
- ii. shall Watson-Marlow be liable for any special, indirect, incidental, consequential, or exemplary damages, however arising, even if Watson-Marlow has been advised of the possibility of such damages.

Watson-Marlow shall not be liable for any loss, damage, or expense directly or indirectly related to or arising out of the use of its products, including damage or injury caused to other products, machinery, buildings, or property. Watson-Marlow shall not be liable for consequential damages, including without limitation, lost profits, loss of time, inconvenience, loss of product pumped, and loss of production.

This warranty does not obligate Watson-Marlow to bear any costs of removal, installation, transportation, or other charges which may arise in connection with a warranty claim.

Watson-Marlow shall not be responsible for shipping damage of returned items.

Conditions

- o Products must be returned by pre-arrangement to Watson-Marlow, or a Watson-Marlow approved service centre.
- o All repairs or modifications must have been made by Watson-Marlow Ltd, or a Watson-Marlow approved service centre or with the express permission in writing of Watson-Marlow, signed by a manager or director of Watson-Marlow.
- o Any remote control or system connections must be made in accordance to Watson-Marlow recommendations.
- o All PROFIBUS systems must be installed or certified by a PROFIBUS approved installation engineer.

Exceptions

- o Consumable items including tubing and pumping elements are excluded.
- o Pumphead rollers are excluded.
- o Repairs or service necessitated by normal wear and tear or by lack of reasonable and proper maintenance are excluded.
- o Products which, in the judgement of Watson-Marlow, have been abused, misused, or subject to malicious or accidental damage or neglect are excluded.
- o Failure caused by electrical surge is excluded.
- o Failure caused by incorrect or sub-standard system wiring is excluded.
- o Damage by chemical attack is excluded.
- o Ancillaries such as leak detectors are excluded.
- o Failure caused by UV light or direct sunlight.
- o Any attempt to disassemble a Watson-Marlow product will invalidate the product warranty.

Watson-Marlow reserves the right to amend these terms and conditions at any time.

7 Safety notes

This safety information should be used in conjunction with the rest of this operating manual.

In the interests of safety, this pump and pumphead should only be used by competent, suitably trained personnel after they have read and understood the manual and considered any hazard involved. If the pump is used in a manner not specified by Watson-Marlow Ltd, the protection provided by the pump may be impaired. Any person who is involved in the installation or maintenance of this equipment should be fully competent to carry out the work. In the UK this person should also be familiar with the Health and Safety at Work Act 1974.



This symbol, used on the pump and in the manual, means: Caution, refer to accompanying documents.



This symbol, used on the pump and in the manual, means: Do not allow fingers to contact moving parts.



This symbol, used on the pump and in the manual, means: Caution, hot surface.



This symbol, used on the pump and in the manual, means: Caution, risk of electric shock.



This symbol, used on the pump and in the manual, means: Personal Protective Equipment (PPE) must be worn.



This symbol, used on the pump and in the manual, means: Recycle this product under the terms of the EU Waste Electrical and Electronic Equipment (WEEE) Directive.



Fundamental work with regard to lifting, transportation, installation, starting-up, maintenance and repair should be performed by qualified personnel only. The unit must be isolated from mains power while work is being carried out. The motor must be secured against accidental start-up.



Some pumps weigh more than 18kg (the exact weight depends on the model and pumphead - see on the pump). Lifting should be performed according to standard Health and Safety guidelines. Finger recesses are built into the sides of the lower shell for convenience in lifting; in addition, the pump can conveniently be lifted by grasping the pumphead and (where fitted) the 'N' module at the rear of the pump.



There is a user-replaceable type fuse in the fuse holder in the centre of the switch-plate at the back of the pump. In some countries, the mains power plug contains an additional replaceable fuse.



There are no user-serviceable fuses or parts inside this pump.

This pump must be used only for its intended purpose.

The pump must be accessible at all times to facilitate operation and maintenance. Access points must not be obstructed or blocked. Do not fit any devices to the drive unit other than those tested and approved by Watson-Marlow. Doing so could lead to injury to persons or damage to property for which no liability can be accepted.

The pump's main plug is the disconnecting device (for isolating the motor drive from the mains supply in an emergency). Do not position the pump so that it is difficult to disconnect the mains plug.



If hazardous fluids are to be pumped, safety procedures specific to the particular fluid and application must be put in place to protect against injury to persons.



This product does not comply with the ATEX directive and must not be used in explosive atmospheres.



Ensure the chemicals to be pumped are compatible with the pumphead, lubricant (where applicable), tubing, pipework and fittings to be used with the pump. Please refer to the chemical compatibility guide which can be found at: www.wmftg.com/chemical. If you need to use the pump with any other chemical please contact Watson-Marlow to confirm compatibility.



Pump will start as soon as power is applied if Auto restart is on and pump was running when power was disconnected.

There are moving parts inside the pumphead. Before opening the tool-unlockable guard or tool-unlockable track, ensure that the following safety directions are followed:



1. Ensure the pump is isolated from the mains power.

2. Ensure that there is no pressure in the pipeline.



3. If a tube failure has occurred, ensure that any fluid in the pumphead has been allowed to drain to a suitable vessel, container or drain.

4. Ensure that appropriate Personal Protective Equipment (PPE) is worn.



Primary operator protection from rotating parts of the pump is provided by the pumphead safeguard. Note that safeguards differ, depending on the type of pumphead. See the pumphead section of the manual.

8 Pump specifications

8.1 Specification ratings

Operating temperature	5C to 40C (41F to 104F)
Storage temperature	530: -40C to 70C (-40F to 158F)
Humidity (non-condensing)	80% up to 31C (88F) decreasing linearly to 50% at 40C (104F)
Maximum altitude	2000m (6560ft)
Power consumption	530: 135VA
Supply voltage	Filtered 100-120V/200-240V 50/60Hz 1pH
Maximum voltage fluctuation	+/-10% of nominal voltage. A well regulated electrical mains supply is required along with cable connections conforming to the best practice of noise immunity
Full load current	530: <0.6A@ 230V; <1.25A @ 115V
Fuse rating	530: Ceramic, 5x20mm, 2.5A, 250V AC, Time Delay
Installation category (overvoltage category)	II
Pollution degree	2
IP	IP31 to BS EN 60529 if supplied with N module then IP66 to BS EN 60529. Equivalent to NEMA 4X to NEMA 250 *(indoor use - protect from prolonged UV exposure)
dB rating 	530: < 70dB (A) @ 1m
Control ratio	530: 0.1-220rpm (2200:1)
Maximum speed	530: 220rpm

8.2 Weights

530	Drive only		+ 520R, 520R2		+ 520REL, 520REM, 520REH		+ 505L	
IP31	9.7kg	21lb 6oz	10.6kg	23lb 5oz	10.5kg	23lb 3oz	12.2kg	26lb 14oz
IP66	10.6kg	23lb 5oz	11.5kg	25lb 5oz	11.4kg	25lb 2oz	13.1kg	28lb 13oz

Weights warning



Some pumps weigh more than 18kg (the exact weight depends on the model and pumphead - see on the pump). Lifting should be performed according to standard Health and Safety guidelines. Finger recesses are built into the sides of the lower shell for convenience in lifting; in addition, the pump can conveniently be lifted by grasping the pumphead and (where fitted) the 'N' module at the rear of the pump.

8.3 Pumphead options

530 pump range

520R, 501RL, 313, 314, 505L, 505BA, 505CA, 314MC, 318MC:



9 Good pump installation practice

9.1 General recommendations

It is recommended that the pump is sited on a flat, horizontal, rigid surface, free from excessive vibration, to ensure the correct lubrication of the gearbox and correct pumphead operation. Allow a free flow of air around the pump to ensure that heat can be dissipated. Ensure that the ambient temperature around the pump does not exceed the recommended maximum operating temperature.

The STOP key on pumps supplied with a keypad will always stop the pump. However, it is recommended that a suitable local emergency stop device is fitted into the mains supply to the pump.

Do not stack the pumps more than the recommended maximum number. When the pumps are stacked, ensure that the ambient temperature around all the pumps in the stack does not exceed the recommended maximum operating temperature.



The pump may be set up so that the direction of rotor rotation is clockwise or counter-clockwise, whichever is convenient.

Please note, however, that for some pumpheads the tube life will be greater if the rotor rotates clockwise; and that performance against pressure will be maximised if the rotor rotates counter-clockwise. To achieve pressure in some pumpheads the pump must rotate counter-clockwise.

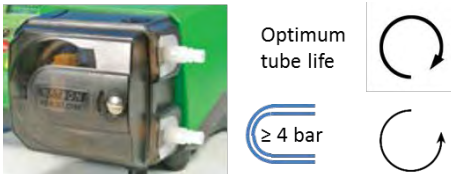

Peristaltic pumps are self-priming and self-sealing against backflow. No valves are required in inlet or discharge line, except those specified as below.



Users must fit a non-return valve between the pump and the discharge pipework to avoid the sudden release of pressurised fluid in the event of a pumphead or tube failure. This shall be fitted immediately after the discharge of the pump.

Valves in the process flow must be opened before the pump operates. Users are advised to fit a pressure relief device between the pump and any valve on the discharge side of the pump to protect against damage caused by accidental operation with the discharge valve closed.

9.2 Dos and don'ts

- Do not build a pump into a tight location without adequate airflow around the pump.
- Do keep delivery and suction tubes as short and direct as possible - though ideally not shorter than one metre - and follow the straightest route. Use bends of large radius: at least four times the tubing diameter. Ensure that connecting pipework and fittings are suitably rated to handle the predicted pipeline pressure. Avoid pipe reducers and lengths of smaller bore tubing than the pumphead section, particularly in pipelines on the suction side. Any valves in the pipeline must not restrict the flow. Any valves in the flow line must be open when the pump is running.
- Do ensure that on longer tube runs at least one metre of smooth bore, flexible tubing is connected to the inlet and discharge port of the pumphead to help to minimise impulse losses and pulsation in the pipeline. This is especially important with viscous fluids and when connecting to rigid pipework.
- Do use suction and delivery pipes equal to or larger than the tubing diameter bore. When pumping viscous fluids use pipe runs with a bore several times larger than the pump tube.
- Do site the pump at or just below the level of the fluid to be pumped if possible. This will ensure flooded suction and maximum pumping efficiency.
- Do run at slow speed when pumping viscous fluids. Flooded suction will enhance pumping performance, particularly for materials of a viscous nature.
- Do recalibrate after changing tubing, fluid or any connecting pipework. It is also recommended that the pump is recalibrated periodically to maintain accuracy.
- Do not pump any chemical not compatible with the tube or pumphead.
- Do not run the pump with no tube or element fitted to the pumphead.
- Do not strap the control and mains cable together.
- Do ensure if your product has an N module, that the module is fitted with the seals intact and properly located. Ensure that the holes for the cable glands are properly sealed to maintain the IP/NEMA rating.
- If your pump is a PROFIBUS variant do ensure that it is installed in accordance with PROFIBUS installation guidelines.
- Do not allow tight bends in any PROFIBUS signal cable.

Tube selection: The chemical compatibility guide published on the Watson Marlow website is for guidance. If in any doubt about the compatibility of a tube material and the duty fluid, request a Watson-Marlow tube sample card for immersion trials.

When using Marprene or Bioprene continuous tubing, do re-tension the tube after the first 30 minutes of running.

10 Pump operation

10.1 Keypad Layout and Key IDs



HOME key

When the HOME key is pressed it will return the user to the last known operating mode. If modifying pump settings when the HOME key is pressed, it will disregard any setting changes and return you to the last known operating mode.

FUNCTION keys

FUNCTION keys, when pressed, will perform the function displayed on the screen directly above the relevant function key.

^ and v keys

These keys are used to change the programmable values within the pump. These keys are also used to move the selection bar up and down in the menus.

MODE key

To change modes or mode settings, press the MODE key. The MODE key can be pressed at any time to enter the mode menu. If modifying pump settings when the MODE key is pressed, it will disregard any setting changes and return you to the MODE menu.

10.2 Starting and stopping



10.3 Using up and down keys



10.4 Maximum speed



10.5 Change rotation direction



11 Connecting to a power supply

A well regulated electrical mains supply is required along with cable connections conforming to the best practice of noise immunity. It is not recommended to site these drives alongside 'dirty' electrical mains devices, such as 3-phase contactors and inductive heaters without special attention being paid to unacceptable mains-borne noise.



Set the voltage selector to 115V for 100-120V 50/60Hz supplies or 230V for 200-240V 50/60Hz supplies. Always check the voltage selector switch before connecting to the mains supply or the pump will be damaged.

~100-120V



~200-240V



Make suitable connection to an earthed single-phase mains electricity supply.



If the pump type is one with an 'N' module, the voltage selector is not visible while the module is in place. It is mounted in the switch plate at the rear of the pump, protected from water by the 'N' module. The module must be removed to allow access to the switch plate. Do not switch the pump on unless you have checked that it is set to suit your power supply by removing the module and inspecting the switch and then refitting the module.



1.



2.



3.



4.



5.



6.



7.



8.



9.



10.



We recommend using a commercially available supply voltage surge suppression where there is excessive electrical noise.



Ensure that all power supply cables are adequately rated for the equipment.



The pump must be positioned so that the disconnection device is easily accessible when the equipment is in use.

11.1 Conductor colour coding

Conductor type	European colour	North American colour
Line	Brown	Black
Neutral	Blue	White
Ground	Green/Yellow	Green

12 Start-up check list

Note: See also Tube loading.

- Ensure that proper connections are achieved between the pump and suction and discharge piping.
- Ensure proper connection has been made to a suitable power supply.
- Ensure that the recommendations in the section "Good pump installation practice" on page 15 are followed.

13 Control wiring

13.1 Upper D-connector

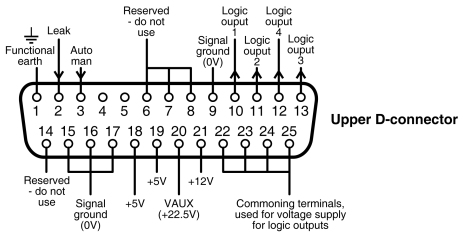

Recommended control cable: 7/0.2mm 24AWG screened. Cable screen should be earthed with a 360 deg connection to a conductive back-shell. This will be connected to pump mains EARTH via the D connector body. Mains Earth is also available on pin 1 Upper D and pin 13 Lower D.

13.2 Lower D-connector

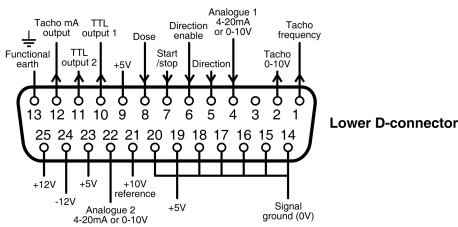

The 0V of this pump is DC isolated (floating) from the pump mains Earth. However, do not allow pump 0V to exceed 10V from the pump mains earth through connection with remote equipment, to avoid overstressing internal 0V to Earth EMI capacitors.



Never apply mains power to the D-connectors. Apply the correct signals to the pins shown. Limit signals to the maximum values shown. Do not apply voltage across other pins. Permanent damage, not covered by warranty, may result.



Keep 4-20mA and low voltage signals separate from mains power. Use separate glanded input cables.

















Ensure that multi strand wires are terminated with a crimp, suitable for the wire diameter. Failure to do so may result in electric shock.







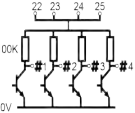

13.3 Standard - 25 way D: Inputs and Outputs

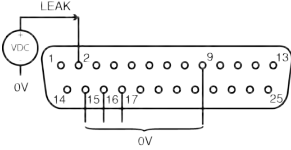



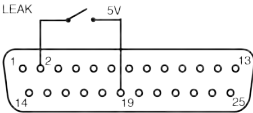

Note: Not all functions may be available, those available will depend on your pump model.



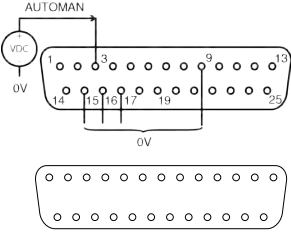

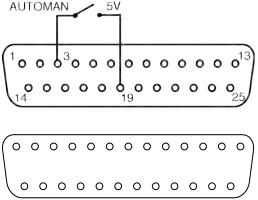
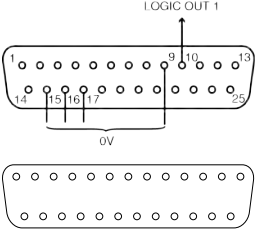

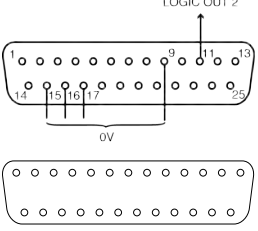
Key to symbols

 RUN	 INPUT	 DRY (NO LEAK)
 STOP	 OUTPUT	 WET (LEAK DETECTED)
 CLOCKWISE ROTATION	 MANUAL (KEYPAD) CONTROL	 KEYPAD DIRECTION CHANGE
 ANTI-CLOCKWISE ROTATION	 ANALOGUE (4-20mA/0-10V) CONTROL	 REMOTE DIRECTION CHANGE
 ALARM OUTPUT (OPEN COLLECTOR TO GROUND)	 START DOSE ON RISING EDGE	 ALARM PULL UP RESISTOR COMMON

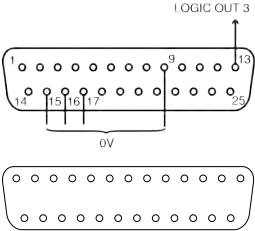

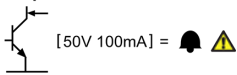
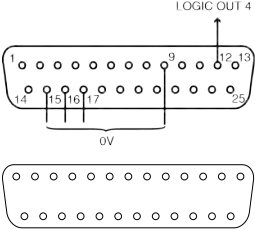

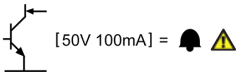
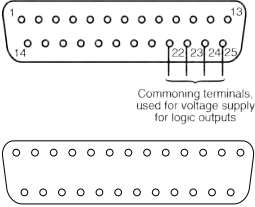

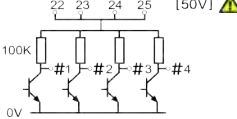
Wiring the upper D connector



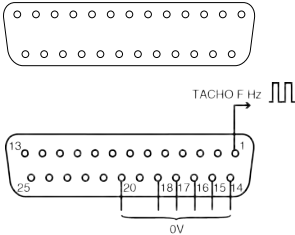

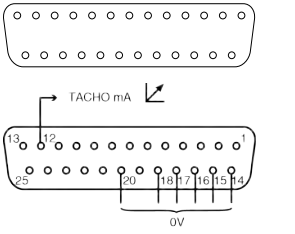

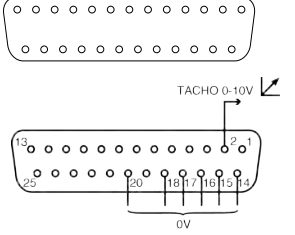



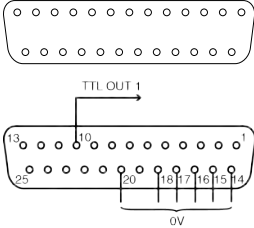

Signal Name	Input or output	Configurable	Signal response
<p>LEAK</p> 		Yes	<p>Leak = high</p> 0 =  1 [5-24V] =  
			<p>Leak = low</p> 0 =   1 [5-24V] = 

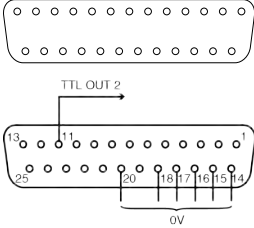



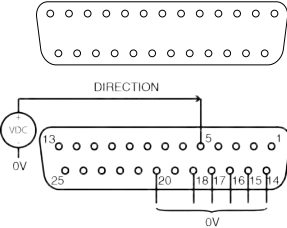



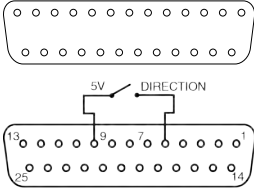

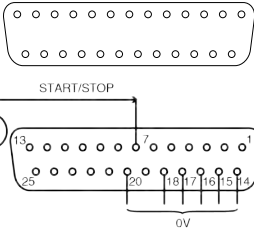
Signal Name	Input or output	Configurable	Signal response
<p>AUTO/MAN</p> 		No	$0 = \text{hand icon}$ $1 [5-24V] = \text{lightning bolt icon} \text{ warning icon}$
			
<p>LOGIC OUT 1</p> 		Yes	<p>Output 1</p>  $[50V 100mA] = \text{bell icon} \text{ warning icon}$
<p>LOGIC OUT 2</p> 		Yes	<p>Output 2</p>  $[50V 100mA] = \text{bell icon} \text{ warning icon}$







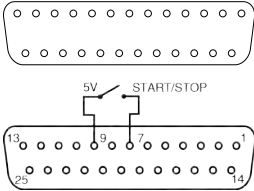

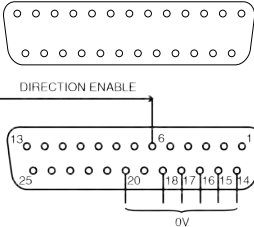
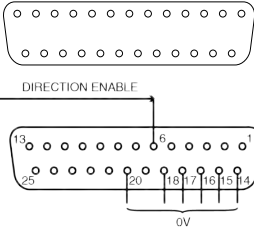
Signal Name	Input or output	Configurable	Signal response
<p>LOGIC OUT 3</p> 		<p>Yes</p>	<p>Output 3</p> 
<p>LOGIC OUT 4</p> 		<p>Yes</p>	<p>Output 4</p> 
<p>COMMON</p>  <p>Commoning terminals, used for voltage supply for logic outputs</p>		<p>No</p>	

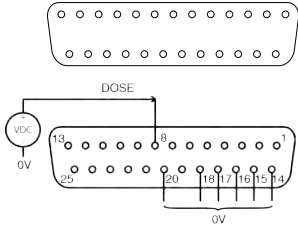

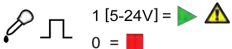
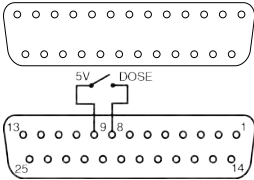
Wiring the lower D connector

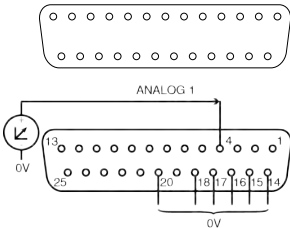
Function	Input or output	Configurable	Signal response
<p>TACHO FREQUENCY</p> 		No	5V TTL 1mA = 
<p>TACHO</p> 		No	0-10V/4-20mA
		No	0-10V

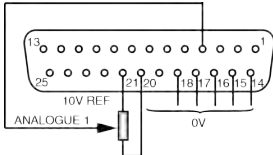
Function	Input or output	Configurable	Signal response
<p>TTL 1</p> 		<p>Yes</p>	<p>Output 1 5V TTL 1mA =  </p>
<p>TTL 2</p> 		<p>Yes</p>	<p>Output 2 5V TTL 1mA =  </p>
<p>DIRECTION</p> 		<p>No</p>	<p>0 =  1 [5-24V] =  </p>
			

Function	Input or output	Configurable	Signal response
<p>START/STOP</p> 		<p>Yes</p>	<p>Stop = high</p> <p>0 =  </p> <p>1 [5-24V] = </p> <p>Stop = low</p> <p>0 = </p> <p>1 [5-24V] =  </p>
			
<p>DIRECTION ENABLE</p> 			

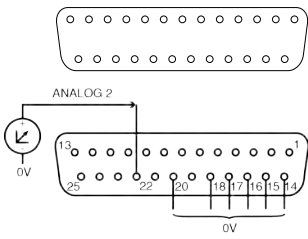
Function	Input or output	Configurable	Signal response
<p>DOSE</p> 		No	
		No	
<p>ANALOG 1</p> 		No	0-10V/4-20mA
		No	0-10V

Function	Input or output	Configurable	Signal response
ANALOG 2 		No	$0-10V/4-20mA$ $[34K/250R] = \nabla$

13.4 Standard - 25 way D: power supply limits

Signal	Connector	Pin numbers	Voltage	Load
5V Ref	Upper	18, 19	5V @ no load	Total of all pins 10mA max
	Lower	9, 19, 23		
12V Ref	Upper	21	12V @ no load	Total of all pins 10mA max
	Lower	25		
10V Ref	Lower	21	10V @ no load	Minimum load 4K7 ohms
VAUX	Upper	21	Nom 22V (18-35V unregulated)	10mA Nom (100mA fused)

13.5 N - Modules Standard and SCADA



The recommended cable and cable glands must be used for the IP66 (NEMA 4X) version of the pump; otherwise ingress protection may be impaired.



Ensure that the module cover is correctly secured at all times by all screws supplied. Failure to do so may compromise the IP66 (NEMA 4X) protection.



Ensure that unused openings on the module are sealed using the blanking plugs provided. Failure to do so may compromise the IP66 (NEMA 4X) protection.

13.6 Standard N - Module

Note: Not all functions may be available, those available will depend on your pump model.

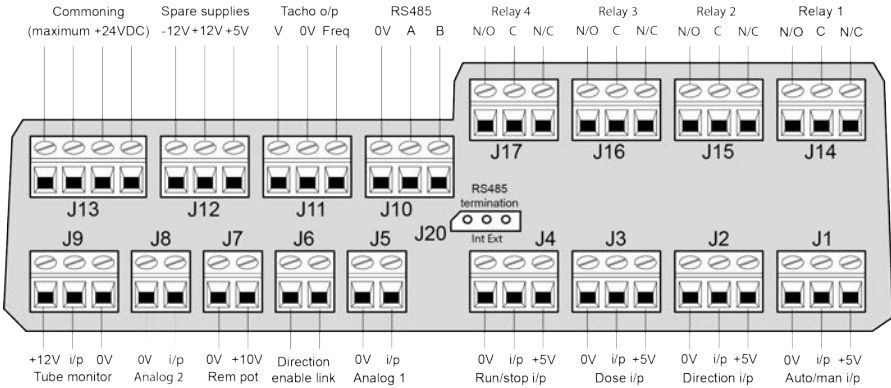















Recommended control cable: metric = 0.14sq mm - 2.5sq mm solid and 0.14sq mm - 1.5sq mm stranded. USA = 26AWG - 14AWG solid and 26AWG - 16AWG stranded. Cable: circular. Max/min outside diameter to ensure a seal when passed through the standard gland: 9.5mm-5mm. **The cable section must be circular to ensure a seal.**













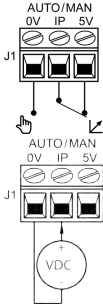

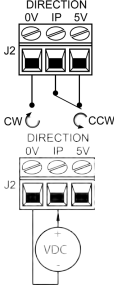

Never apply mains power to the terminals within the N module. Apply the correct signals to the terminals. Limit signals to the maximum values shown. Do not apply voltage across other terminals. Permanent damage, not covered by warranty, may result. The maximum rating on the relay contacts of this pump is 30V DC; maximum load 30W.

Note: Also suitable for low power: ie, 1mA at 5V DC minimum.

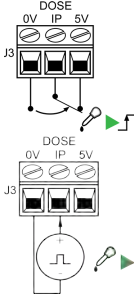





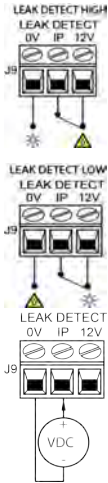

Key to symbols

 RUN	 INPUT	 DRY (NO LEAK)
 STOP	 OUTPUT	 WET (LEAK DETECTED)
 CLOCKWISE ROTATION	 MANUAL (KEYPAD) CONTROL	 KEYPAD DIRECTION CHANGE
 ANTI-CLOCKWISE ROTATION	 ANALOGUE (4-20mA/0-10V) CONTROL	 REMOTE DIRECTION CHANGE
	 EXTERNAL VOLTAGE INPUT	 START DOSE ON RISING EDGE

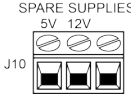
Standard N Module: Input/output Connectors

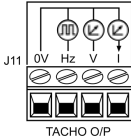
Connector No.	Function	Input or output	Configurable	Signal response
J1			No	<p>0 = </p> <p>1 [5-24V] =  </p>
J2			No	<p>0 = </p> <p>1 [5-24V] =  </p>
J3			No	<p>0 =   1 [5-24V] =  </p> <p>0 = </p>

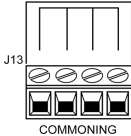
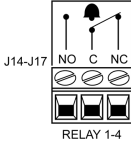
Connector No.	Function	Input or output	Configurable	Signal response
J4	<p>STOP HIGH RUN /STOP 0V IP 5V</p> <p>STOP LOW RUN /STOP 0V IP 5V</p> <p>RUN /STOP 0V IP 5V</p> <p>VDC</p>		Yes	<p>Stop = high</p> <p>0 = </p> <p>1 [5-24V] = </p> <p>Stop = low</p> <p>0 = </p> <p>1 [5-24V] = </p>
J5	<p>ANALOGUE 1 0V IP</p>		No	<p>0-10V/4-20mA [34K/250R] = </p>
J6	<p>DIRECTION EN 0V 1P</p>		No	<p>O/C = </p> <p>0 = </p>
J7	<p>REMOTE POT 0V 10V</p>		No	10V 10mA Max
J8	<p>ANALOGUE 2 0V IP</p>		No	<p>0-10V/4-20mA [34K/250R] = </p>

Connector No.	Function	Input or output	Configurable	Signal response
J9			Yes	<p>Leak = high</p> <p>0 = ☀</p> <p>1 [5-24V] = ⚠ ⚠</p> <p>Leak = low</p> <p>0 = ⚠ ⚠</p> <p>1 [5-24V] = ☀</p>
J10			No	10mA DC Max
J11			No	<p>Hz=5V TTL</p> <p>V=0-10V</p> <p>I=4-20mA</p>
J13				
J14,15,16,17			Yes	 <p>LOW=N/C</p> <p>HIGH=N/O</p> <p>24V DC MAX</p>

13.7 SCADA N-Module

Note: Not all functions may be available, those available will depend on your pump model.

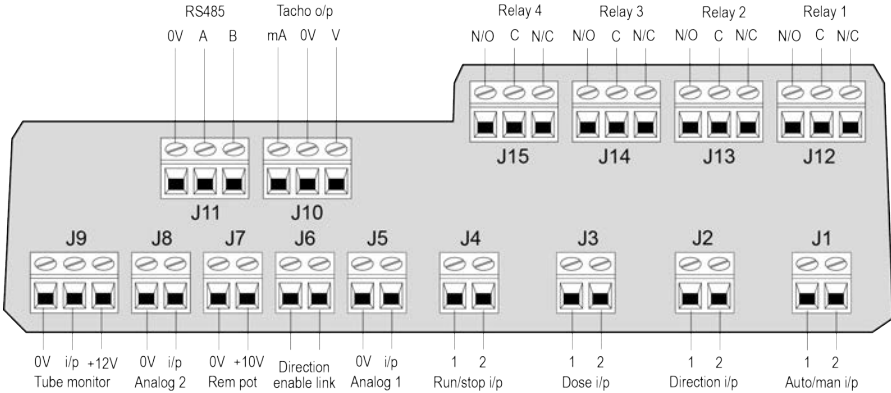















Recommended control cable: metric = 0.14sq mm - 2.5sq mm solid and 0.14sq mm - 1.5sq mm stranded. USA = 26AWG - 14AWG solid and 26AWG - 16AWG stranded. Cable: circular. Max/min outside diameter to ensure a seal when passed through the standard gland: 9.5mm-5mm. **The cable section must be circular to ensure a seal.**













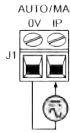



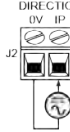



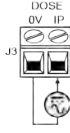





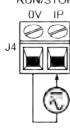



Never apply mains power above 130V AC to the terminals within the SCADA module. Apply the correct signals to the terminals shown. Limit signals to the maximum values shown. Do not apply voltage across other terminals. Permanent damage, not covered by warranty, may result.

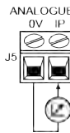





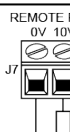

The maximum rating on the relay contacts of this pump is 1250VA.

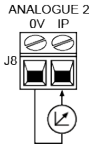
Key to symbols

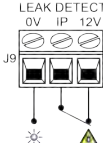
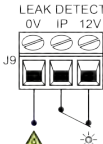
 RUN	 INPUT	 DRY (NO LEAK)
 STOP	 OUTPUT	 WET (LEAK DETECTED)
 CLOCKWISE ROTATION	 MANUAL (KEYPAD) CONTROL	 KEYPAD DIRECTION CHANGE
 ANTI-CLOCKWISE ROTATION	 ANALOGUE (4-20mA/0-10V) CONTROL	 REMOTE DIRECTION CHANGE
	 AC (ALTERNATING CURRENT) INPUT	 START DOSE ON RISING EDGE

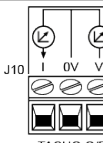
SCADA N Module: Input/output Connectors

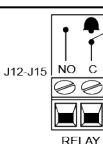
Connector No.	Function	Input or Output	Configurable	Signal Response
J1	AUTO/MAN OV IP 		No	0 =  1 [110VAC] = 
J2	DIRECTION OV IP 		No	0 =  1 [110VAC] = 
J3	DOSE OV IP 		No	  1 [110VAC] =  0 = 
J4	RUN/STOP OV IP 		Yes	Stop = high 0 =  1 [110VAC] =  Stop = low 0 =  1 [110VAC] = 
J5	ANALOGUE 1 OV IP 		No	0-10V/4-20mA [34K/250R] = 
J6	DIRECTION EN OV IP 		No	O/C =  0 = 
J7	REMOTE POT OV 10V 		No	10V 10mA Max

Connector No.	Function	Input or Output	Configurable	Signal Response
J8	ANALOGUE 2 0V IP 		No	0-10V/4-20mA [34K/250R] = ↗
J9	LEAK DETECT 0V IP 12V  LEAK DETECT 0V IP 12V 		Yes	Leak = high 0 = ☀ 1 [5-24V] = ⚠ ⚠ Leak = low 0 = ⚠ ⚠ 1 [5-24V] = ☀
J10	 TACHO O/P		No	0-10V 4-20mA
J12,J13,J14,J15	 RELAY 1-4		Yes	 LOW=N/C HIGH=N/O 110VAC MAX

13.8 Standard - 9 way D - RS232 Use

Recommended control cable: 7 strands 0.2mm 24AWG screened, circular, up to 25 core. The cable screen should be earthed either through the metalwork of the shell by use of the screened back shell.

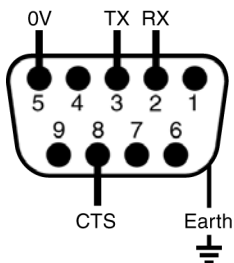

Network commands and protocol

The 530 pump allows you to choose whether you would like to use the historical basic protocol or the new enhanced protocol.

New enhanced protocol

Command strings have a comma separated format, without spaces and with an optional checksum, enclosed within a start of message (SOM) indicator and an end of message (EOM) indicator.

SOM,address,command,parameter,(parameter,parameter,...)checksum,EOM

e.g. <1,SP,103.2,CS>

Message structure - additional definitions

SOM <

Address range: 1 to 16 for RS232 and 1 to 32 with RS485, leading zeros are not required but can be present

EOM >

Command	Parameter	Meaning
CA	-	Clear LCD display
CH	-	Home the cursor
DO	Num1, or Num1,Num2	Set and run one dose of Num1 tach pulses. Note that "Num2", is optional and specifies the number of drip tach pulses (maximum 11000) (see Note 2)
TC	-	Clear the cumulative tachometer count
SP	Num1 or Num1,Num2	Set speed to Num1 RPM (Range 0.1 - 999.9 in steps of 0.1)
SI	-	Increment the speed by 1 RPM
SD	-	Decrement the speed by 1 RPM
GO	-	Start running
ST	-	Stop running
RC	-	Change direction
RR	-	Set direction to clockwise
RL	-	Set direction to counter-clockwise
RS	-	Return status (see Note 3)
RT	-	Return the total deci pump revolutions count
W	"Line1","Line2","Line3","Line4",	Display text on 1 to 4 lines (lines 2,3 and 4 are optional so that between 1 and 4 lines can be displayed). The text must be enclosed by a comma, as shown. The allowable characters are: ! # % ' () + , - . / 0 1 2 3 4 5 6 7 8 9 ; < = > ? A B C D E F G H I J K L M N O P Q R S T U V W X Y Z a b c d e f g h i j k l m n o p q r s t u v w x y z
ZY	-	Return) for stopped or 1 for running. This is returned to the sender in the following format: SOM, address,) or 1, checksum, EOM e.g. <1,0,47>

NOTES: New enhanced protocol	
Note 1:	The Checksum is calculated as the 1's complement of the least significant 8 bits of the unsigned sum of the individual bytes that form the message (excluding the checksum, SOM and EOM indicators) converted into two ASCII-HEX characters. The sender can choose to omit the checksum and can instead enter ??
Note 2:	The correlation between the tachometer pulses and the motor rotation is fixed and provides a measurable and absolute way of monitoring the number of revolutions of the gearbox output shaft - 10892 pulses per revolution. This in turn allows the count to be equated to the amount of material dispensed - assuming that the pumphead type and tube size are known.
Note 3:	The status is returned to the sender in the following format: SOM,address,pumptype,ml/rev/pumphead,tubesize,speed,CW or CCW ,pumpnumber,pump revs count,0 or 1 (for stopped or running),Leak detect (0=Inactive, 1=Active),Auto/Manual(0=Manual, 1=Auto),Adapter detect(0=not fitted,1=fitted),Direction enable(0=disabled, 1=enabled),Spare1 input4 (0=inactive, 1=active),Spare2 input5 (0=inactive,1=active),checksum,EOM e.g. <1,530Du,15.12,520R,9.6,220.0,CW,123456789,12345,1,0,0,0,0,0,CS>
Note 4:	The following commands shall not be executed if the pump network ID in the command is replaced with all zeros, indicating a broadcast message for all pumps. RS,RT,ZY
Note 5:	There is a timeout on this protocol, once a start of message is received a timer shall be started. If the end of message is not received before the time expires, the message shall be deleted and the pump shall continue to wait for the next message. The timeout is pre-calculated for each baud rate

Historical basic protocol

Command	Parameter	Meaning
nCA	-	Clear display
nCH	-	Home the cursor
nDO	xxxxxxxxx <,yyyyy>	Set and run one dose of xxxxxxxxxxxx tacho pulses, with optional drip of yyyyy (maximum 11,000) tacho pulses. See Note 1
nTC	-	Clear the cumulative tachometer count
nSP	xxx.x	Set speed to xxx.x rpm
nSI	-	Increment the speed by 1 rpm
nSD	-	Decrement the speed by 1 rpm
nGO	-	Start running
nST	-	Stop running
nRC	-	Change direction
nRR	-	Set direction to clockwise
nRL	-	Set direction to counter-clockwise

Command	Parameter	Meaning
nRS	-	Return status. See Note 2
nRT	-	Return the cumulative tachometer count
nW	[line1]~[line2]~[line3]~[line4]@	Display text on 1 to 4 lines with ~ as the line delimiter. Terminated by the @ character. See Note 3
nZY	-	Return 0 for stopped or 1 for running.
NOTES: Historical basic protocol		
Note 1: The correlation between the tachometer pulses and the motor rotation is fixed and provides a measurable and absolute way of monitoring the number of revolutions of the gearbox output shaft - 10,892 pulses per revolution. This in turn allows the count to be equated to the amount of material dispensed - assuming that the pumphead type and tube size are known.		
Note 2: The status is returned to the sender in the following format: [pump type] [ml/rev] [pumphead] [tube size] [speed] [CW/CCW] P/N [pump number] [tacho count] [0/1(stopped / running)] ! For example: 520Du 15.84 520R 9.6MM 220.0 CW P/N 1 123456789 1 !		
Note 3: 1 to 4 lines of text can be written with ~ as the line delimiter and @ as the message end. i.e., 1W520Du@ and 1W520Du~@ are both valid commands		
Note 4: In all cases, 'n' can be any number from 1 to 16 inclusive, and by exception the # symbol can be used as an all-drives command; but not with the RS, RT or ZY commands, as the results would be indeterminate.		

14 Switching the pump on for the first time

Power up the pump. The pump displays the start-up screen with the Watson-Marlow Pumps logo for three seconds.



2. Your selected language will now be displayed on screen. Choose **CONFIRM** to continue. All text will now appear in your chosen language.



14.1 Selecting the display language

1. Use the ^/v keys to select your chosen language, and press **SELECT**.



3. Choose **REJECT** to return to the language choice screen. This then proceeds to the home screen.



14.2 First-time start-up defaults

The pump is preset with operational parameters as shown in table below.

Parameter	530 default
Language	Not set
Default mode	Manual
Default manual speed	220rpm
Pump status	Stopped
Max speed	220rpm
Direction	CW
Pumphead	520R2
Tube size	9.6mm
Tube material	Bioprene
Flow calibration	15.12 ml/rev
Flow units	rpm
SG value	1
Keypad lock	Disabled
Auto-restart	OFF
Analog signal type	mA
Analog scaling type	mA
Analog min current	5mA
Analog max current	19mA
Analog min flow rate/rpm	0rpm
Analog max flow rate/rpm	220rpm
Beeper	ON
Security code	Not set
MemoDose flow rate	Mid flow rate of chosen pumphead
MemoDose volume	100ml
Pump number baud rate	9600
Stop bits	2
Profibus node address	126
Remote start/stop input	High = stop
Leak detector input	High = leak
Input 4	Disabled
Input 5	Disabled
Output 1	Run/stop
Output 1 - status	High = run

Parameter	530 default
Output 2	Direction
Output 2 - status	High = CW
Output 3	Auto/man
Output 3 - status	High = auto
Output 4	General alarm
Output 4 - status	High = alarm

The pump is now ready to operate according to the defaults listed above.

Note: The display background colour changes according to running state as follows:

- White background indicates pump stopped
- Grey background indicates pump running
- Red background indicates error or alarm

All operating parameters may be changed by means of key-presses (see section "Pump operation" on page 17).

15 Switching the pump on in subsequent power cycles

Subsequent power-up sequences will jump from the start-up screen to the home screen.

- The pump runs a power-on test to confirm proper functioning of the memory and hardware. If a fault is found, an error code is displayed.
- The pump displays the start-up screen with the Watson-Marlow Pumps logo for three seconds followed by the home screen
- Start-up defaults are those in place when the pump was switched off last

Check that the pump is set to operate as you require it. The pump is now ready to operate.

All operating parameters may be changed by means of key-presses (see "Pump operation" on page 17).

Power interruption

This pump has an auto restart feature which, when active, will restore the pump to the operating state it was in when power was lost.

Stop/start power cycles

Do not power up/power down the pump more than 20 times in an hour, whether manually or by means of the auto-restart facility. We recommend remote control where a high frequency of stop/start cycles is required.



Pump will start as soon as power is applied if Auto restart is on and pump was running when power was disconnected.

16 Mode menu

Press **MODE** to display the Change mode menu.

Use the \wedge and \vee keys to scroll through the available modes:

- Manual (default)
- Flow calibration
- Analog
- Network
- MemoDose
- CANCEL

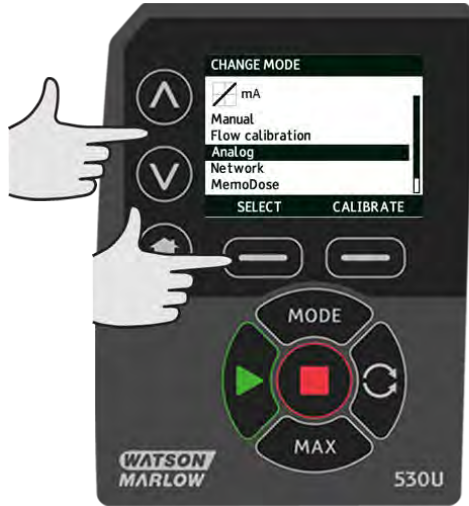

Use **SELECT** to choose mode. Use the right hand function key to alter mode settings.

17 Manual

All settings and functions of the pump in manual mode are set and controlled by means of key-presses. Immediately after the start-up display sequence detailed in: "Switching the pump on in subsequent power cycles" on page 44, the manual mode home screen will be displayed unless auto restart is enabled.

If enabled, the pump will return to the last known operating state when the power was lost. When the pump is running it displays an animated clockwise arrow. In normal operation, the direction of flow is into the bottom port of the pumphead and out of the top port.

If an exclamation mark (!) is displayed, it indicates that Auto restart is on (see "Main menu" on page 77). If a padlock icon shows, it indicates that the keypad lock is on.

17.1 START



Starts the pump at the current flow displayed, and the display background changes to grey. If the pump is running, pressing this has no effect.

17.2 STOP



Stops the pump. The display background changes to white. If the pump is not running pressing this has no effect.

17.3 INCREASING AND DECREASING FLOW RATE



Using the \wedge and \vee keys will increase or decrease the flow rate.

Decreasing flow rate

- A single key press will decrease flow rate by the least significant digit of the chosen flow rate unit.
- Repeat key presses as required to achieve the desired flow rate.
- Hold down the key for flow rate scrolling.

Increasing flow rate

- A single key press will increase flow rate by the least significant digit of the chosen flow rate unit.
- Repeat key presses as required to achieve the desired flow rate.
- Hold down the key for flow rate scrolling.

17.4 MAX FUNCTION (Manual mode only)



- Press and hold the **MAX** key to run at maximum flow.
- Release the key to stop the pump.
- The volume dispensed and time elapsed are displayed while the **MAX** key is pressed and held.

18 Flow calibration

This pump displays flow rate in ml/min.

18.1 Setting the flow calibration

Using the \wedge / \vee keys, scroll to **Flow calibration** and press **CALIBRATE**.



Using the \wedge / \vee keys, enter the maximum flow rate limit and press **ENTER**.



Press **START** to begin pumping a volume of fluid for calibration.



Press **STOP** to stop pumping fluid for the calibration.



Use the \wedge / \vee keys to enter the actual volume of fluid pumped.



To accept the new calibration press **ACCEPT** or **RE-CALIBRATE** to repeat the procedure. Press **HOME** or **MODE** to abort.



The pump is now calibrated.

19 Analog mode

In this remote operating mode the flow rate will be proportional to the external milliamp or voltage signal input received by the pump. The relationship between the external analog signal and the flow rate is determined by configuring the two points A and B as shown in the graph below. The rate of flow can be proportional or inversely proportional to the analog input.

The default values stored in the pump are A (5mA, 0 rpm) and B (19mA, 220 rpm).

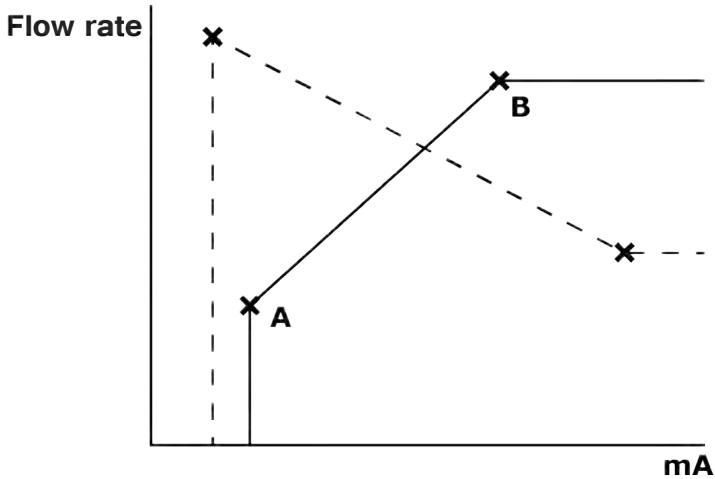

When the analog signal received is greater than the level defined by point A, the run status output will be energised as the pump is running.

To select Analog mode select **MODE**. Using the \wedge / \vee keys, scroll to **Analog** and press **SELECT**.



The analog signal being received by the pump is displayed, for information only, on the INFO screen. Press **INFO** to display this information.



19.1 Analog calibration

The pump must be stopped before attempting to calibrate the values.

High and low signals must be within range. If the signal sent is out of range you will not be able to set the signal input value and progress to the next step in the process.

Select **MENU**, then select **MODE** menu. Using the \wedge / \vee keys, scroll to **Analog** and press **CALIBRATE**.



19.2 Calibrate Input 1

Using the \wedge / \vee keys, scroll to **Analog Input** and press **SELECT**.



Select the input signal type using the \wedge / \vee keys and press **SELECT**.

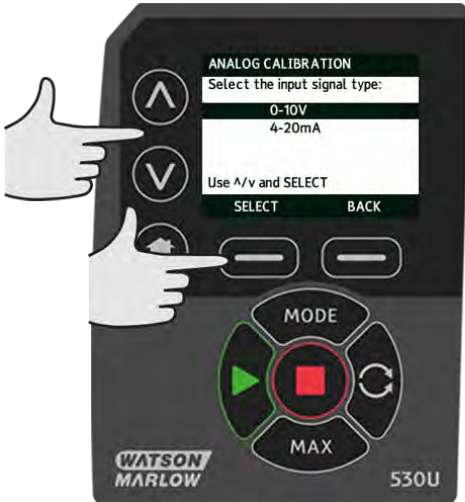

The pump gives the option to enter the high and low mA or V signals manually or via the analog input. Entering mA values is described here, however the process for entering V signals is identical.

Choose whether to enter the current values manually via the keypad, or whether to apply the current signals electrically to the analog input.



19.3 Setting a high signal

Send the high signal input to the pump, or enter the current value using the ^ / v keys.



ACCEPT appears when high mA signal is within tolerance limits. Press **ACCEPT** to accept the high signal input or **CANCEL** to return to the previous screen.

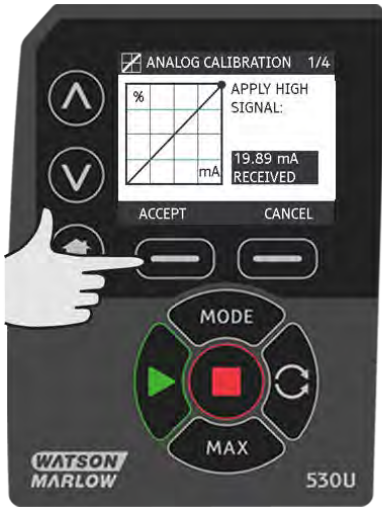

19.4 Setting high flow calibration

Using the \wedge / \vee keys, scroll to the desired flow rate. Select **SET FLOW** or press **BACK** to return to the previous screen.



19.5 Setting a low signal

Send the low signal input to the pump, or enter the current value using the \wedge / \vee keys.



If the range between the low and high signal is less than 1.5mA, the following error message will be displayed.



ACCEPT appears when low mA signal is within tolerance limits. Press **ACCEPT** to accept the low signal input or **CANCEL** to return to the previous screen.

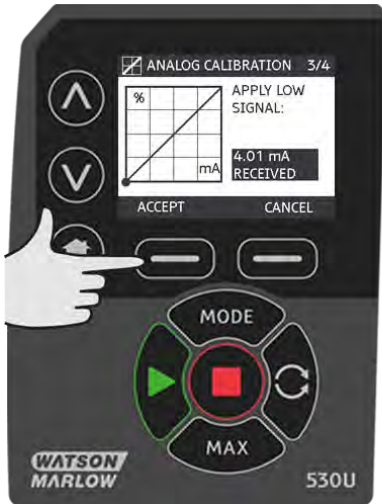

19.6 Setting low flow calibration

Using the \wedge / \vee keys, scroll to the desired scale factor. Select **SET FLOW**.

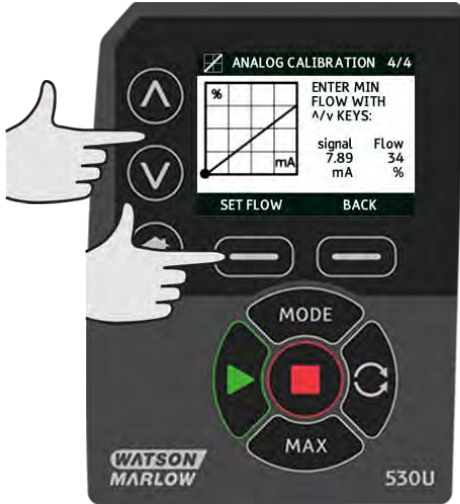

This proceeds to the screen confirming calibration is complete. Select **ANALOG** to start in analog mode or **MANUAL** to continue in manual mode.

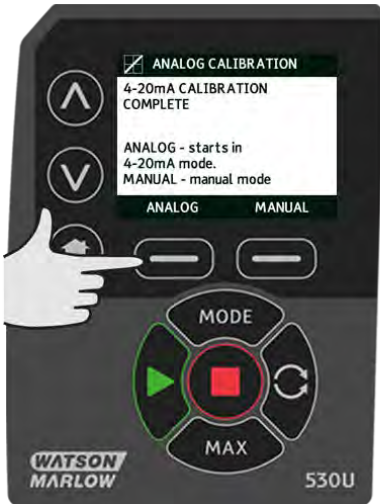

19.7 Calibrating the scaling input

It is possible to scale the speed of the pump remotely by one of these methods: a voltage analog signal within the range 0-10V; or a current analog signal within the range 4-20mA. The speed of the pump as set by Analog 1 is scaled in proportion to the signal from Analog 2 according to the formula $y=as$, where a is the speed set by Analog 1, s is the scaling set by Analog 2, and y is the scaled rotation speed.

Using the \wedge / \vee keys, scroll to **Scaling input** and press **SELECT**.



Select the input signal type, using the \wedge / \vee keys, and press **SELECT**.

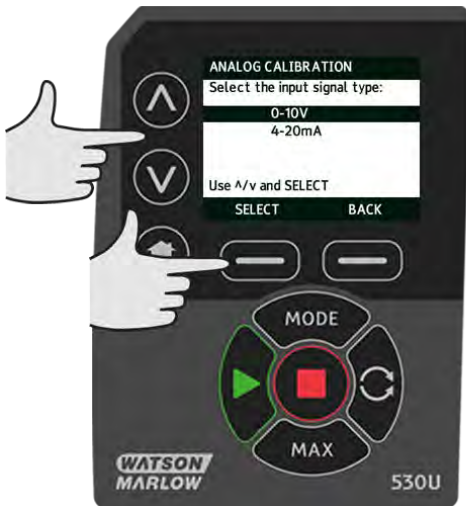

The pump gives the option to enter the high and low mA or V signals manually or via the analog input. Entering mA values is described here and the process for entering Voltage signals is identical.

Choose whether to enter the current values manually via the keypad, or whether to apply the current signals electrically to the analog input.



19.8 Setting a high signal

Send the high signal input to the pump, or enter the current value using the \wedge / \vee keys.



ACCEPT appears when high mA signal is within tolerance limits. Press **ACCEPT** to accept the high signal input or **CANCEL** to return to the previous screen.



19.9 Setting high flow calibration

Using the \wedge / \vee keys, scroll to the desired scale factor. Select **SET SCALE** or press **BACK** to return to the previous screen.

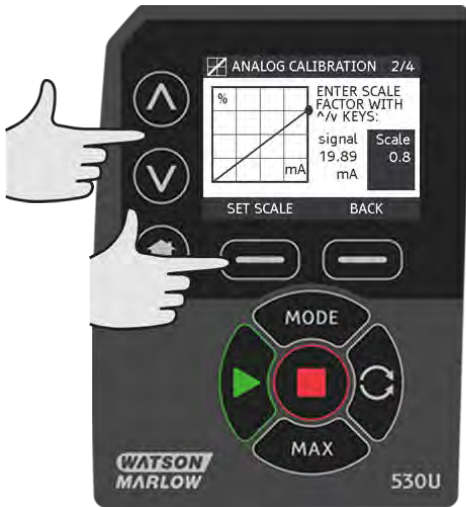

19.10 Setting a low signal

Send the low signal input to the pump, or enter the current value using the \wedge / \vee keys.

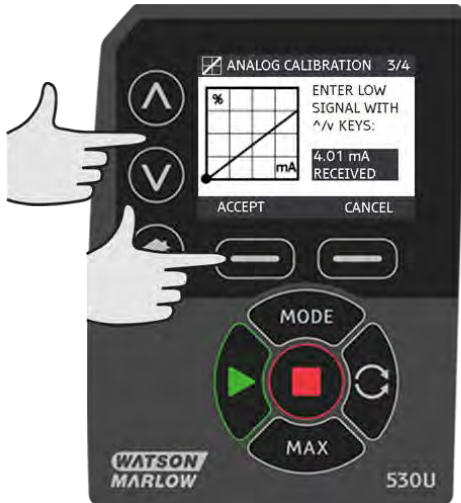

ACCEPT appears when low mA signal is within tolerance limits. Press **ACCEPT** to accept the low signal input or **CANCEL** to return to the previous screen.

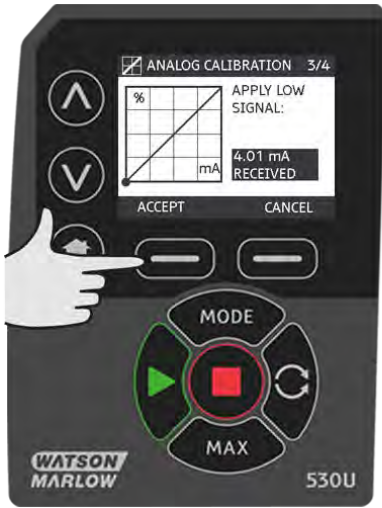

19.11 Setting low flow calibration

Using the \wedge / \vee keys, scroll to the desired flow rate. Select **SET SCALE**.

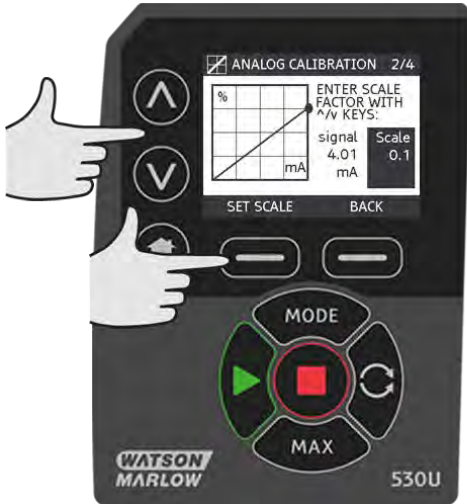

This proceeds to the screen confirming calibration is complete. Select **ANALOG** to start in analog mode or **MANUAL** to continue in manual mode.

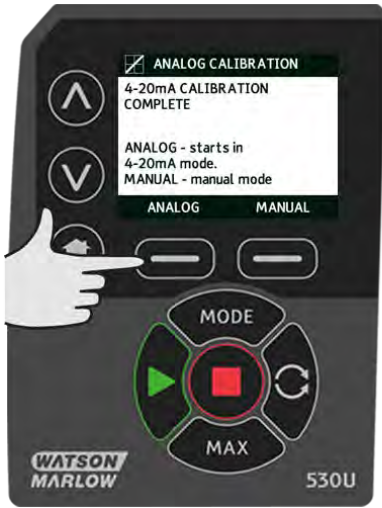

20 Network mode

Check that the pump is ready to run before selecting network operation. Remote control signals may start the pump without warning.

20.1 Network settings

- Select **MODE**
- Using the \wedge/\vee keys, scroll to **Network** and press **SETTINGS**.



RS232 or RS485 are automatically assigned according to the network connection type. If connected to an RS232 network, the following screen is displayed. If connected to an RS485 network, the screen will indicate an RS485 connection.



20.2 Protocol

RS232 or RS485 is automatically assigned according to the network connection.

20.3 Pump No

Pump No will be highlighted first. Adjust the pump number using the \wedge / \vee keys and press **NEXT** to assign the pump number.



Note: If the network protocol is RS485 the maximum number that can be assigned to the pump is 32, otherwise it is 16.

20.4 Baud rate

The baud rate will now be highlighted. Adjust using the \wedge / \vee keys and press **NEXT** to assign and move on.

The following table shows the available baud rates.

	RS232	RS485
Baud rates	1200	1200
	2400	2400
	4800	4800
	9600	9600
	—	19200

20.5 Stop bits

With **Stop bits** highlighted, use the \wedge / \vee keys to select the required value and **NEXT** to change an alternative setting or **FINISH** to save the network settings.

20.6 Save network settings

The following screen is displayed:



Press **SAVE** to save the new network settings or **DISCARD** to discard the new settings and return to the HOME screen.

21 MemoDose mode

Each time the pump is started by pressing **START**, it records the number of pumphead revolutions which occur until **STOP** is pressed. The number of revolutions is proportional to the volume of fluid which has been dispensed: the dose. MemoDose mode allows the user to repeat-dose a precise volume of fluid. This can be achieved by dispensing a master dose, or entering a dose volume manually using the keypad. MemoDose can repeat this dose exactly or proportionately.

21.1 To configure MemoDose

- Select **MODE**
- Using the ^/∨ keys, scroll to **MemoDose** and press **SETTINGS**

Note: the pump must be stopped to enter MemoDose Settings.



21.2 Set flow rate

Using the \wedge / \vee keys, scroll to **Flow rate** and press **SELECT**.



Using the \wedge / \vee keys, enter the dose flow rate and press **SELECT**.



21.3 Resume interrupted doses

MemoDose Mode gives you the opportunity to resume interrupted doses following a power cycle (Note: Auto-restart must be on for this to function). Alternatively interrupted doses can be discarded and a new dose started when power is resumed.

From the MemoDose settings screen, use the \wedge / \vee keys to scroll to **Resume Interrupted Dose** and press **ENABLE**. The red cross will become a green tick to indicate that Resume interrupted dose is enabled. If this function is enabled the **ENABLE** key becomes **DISABLE**. If this is pressed interrupted doses will be discarded after a power cycle.



If resume interrupted doses has been set the following warning screen is displayed, press **CONFIRM** to save this setting.

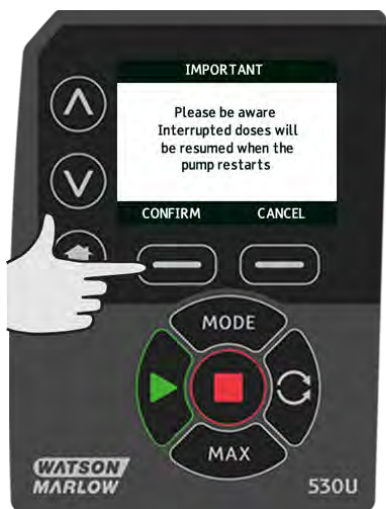

If resume interrupted doses has NOT been set the following warning screen is displayed, press **CONFIRM** to save this setting.



21.4 Master dose

Using the ^/∨ keys, scroll to **Master dose** and press **SELECT**.



The following screen is displayed; press **MANUAL** to enter a dose via the keypad or **DOSE** to dispense a master dose.



Dispensing a master dose

Press **START** to begin dispensing the Master Dose.



Press **STOP** to finish dispensing the Master Dose.



Manual dose entry

Press **MANUAL** on the master dose screen. Using the \wedge / \vee keys enter the required dose volume and press **SELECT** to record the master dose or **CANCEL** to return to MemoDose Settings.



Save dose volume

Press **SAVE** to record the Master Dose or **CANCEL** to return to MemoDose settings.

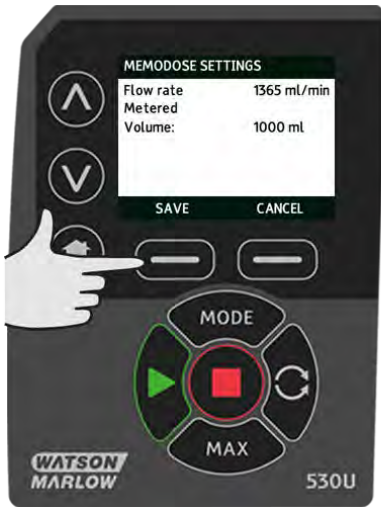

When MemoDose SETTINGS are complete the following screen is displayed; press **MEMODOSE** to start in MemoDose Mode or **BACK** to return to MemoDose settings.

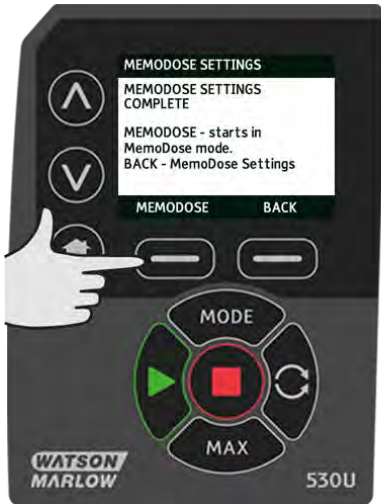

21.5 Manual dosing

From the MemoDose Home screen, press **START** to deliver a dose. The screen displays the dose flow rate and the dose remaining counting down from 100% to 0%.



If the delivered dose differs from the volume required, the percentage may be adjusted within the limits 1% to 999% of the master dose. Use the \wedge / \vee keys to alter the percentage. The new dose size is displayed as a percentage on the home screen.



If **STOP** is pressed during dosing, the pump stops. Pressing **START** will resume, or discard, the interrupted dose depending on the settings in "MemoDose mode" on page 69.

22 Main menu

To access the main menu press the **MENU** button from one of the HOME screens or INFO screens.



This will display the main menu as shown below. Use the \wedge / \vee keys to move the selection bar between the available options.

Press **SELECT** to choose an option.

Press **EXIT** to return to the screen from where the MENU was called.

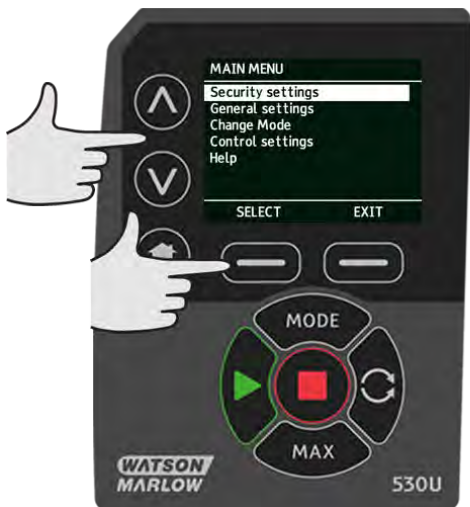

22.1 Security settings

Security settings can be changed by selecting **SECURITY SETTINGS** from the Main menu.

Auto keypad lock

Press **ENABLE/DISABLE** to switch on/off the Auto keypad lock. When active the keypad will 'lock' after 20 seconds of inactivity.



Once locked it will display the screen below when any key is pressed. To unlock the keypad press the two **UNLOCK** keys together.



The padlock icon will appear on the operating mode home screen to show that keypad lock is activated.



Note that the STOP key will always work whether the keypad is locked or not.

PIN protection

Using the ^ / v keys select **PIN protection** from the SECURITY SETTINGS menu and press **ENABLE/DISABLE** to switch on/off the PIN protection. If PIN protection has been enabled, a Master level PIN will be required to disable PIN lock.

Setting Master PIN

Setting the Master PIN protects all functionality. The Master is able to selectively enable functionality for two additional operators. These are defined as User 1 and User 2. They will be able to access this functionality by entering a PIN code assigned to them by the Master user. To set the Master PIN, scroll to Master level and press **ENABLE**.



To define a four digit Master PIN, use the \wedge / \vee keys to select each digit from 0-9. Once you have the required digit press the **NEXT DIGIT** key. After selecting the fourth digit press **ENTER**.



Now press **CONFIRM** to check that the number entered is the PIN you require. Press **CHANGE** to return to PIN entry.



The following screen will be displayed to indicate that the Master PIN has been applied to access all functionality. Press **NEXT** to selectively enable functionality access for User 1 and User 2.



Configure User 1 security settings

The PIN PROTECTION level screen will be displayed with User 1 highlighted, press **ENABLE** to configure User 1 security settings or scroll to configure an alternative User.

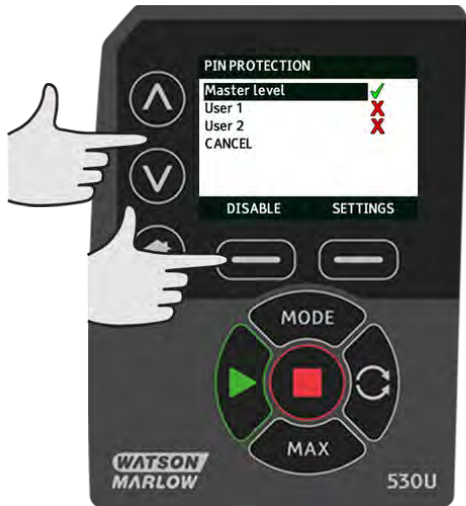

ENABLE user 1 security settings displays the PIN entry screen for User 1. To define a four digit User 1 PIN, use the ^/∨ keys to select each digit from 0-9. Once you have the required digit press the **NEXT DIGIT** key. After selecting the fourth digit press **ENTER**.



Now press **CONFIRM** to verify that the number entered is the PIN you require. Press **CHANGE** to return to PIN entry.



To define the allowed functionality, use the \wedge/\vee keys to select the functionality and press **ENABLE**. User 1 PIN will allow access to only the enabled functionality, to disable functionality, highlight the enabled functionality and press **DISABLE**. When all the required functionality has been enabled, press **FINISH**.



Configure User 2 security settings

The PIN PROTECTION level screen will be displayed with User 2 highlighted, press **ENABLE** to configure User 2 security settings or scroll to configure an alternative User.



ENABLE user 2 security settings displays the PIN entry screen for User 2. To define a four digit User 2 PIN, use the \wedge / \vee keys to select each digit from 0-9. Once you have the required digit press the **NEXT DIGIT** key. After selecting the fourth digit press **ENTER**.



To define the allowed functionality, use the \wedge / \vee keys to select the functionality and press **ENABLE**. User 2 PIN will allow access to only the enabled functionality, to disable functionality, highlight the enabled functionality and press **DISABLE**. When all the required functionality has been enabled, press **FINISH**.

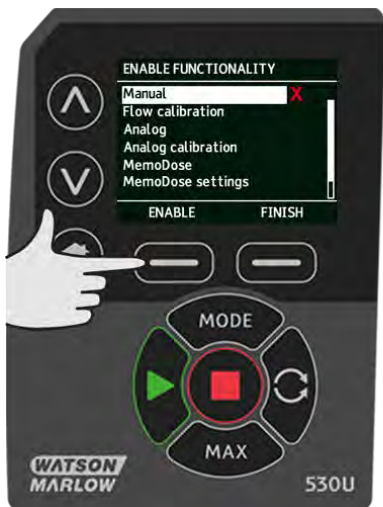

Note: Once Security Settings for User 1 and User 2 have been set by the Master, only the Master PIN will allow access to Security Settings.

The HOME screen will be displayed. A PIN is now required to access all functionality. The Master PIN accesses all pump functionality and the User 1 and User 2 PINs access only the defined functionality. To enter the PIN, use the ^ / v keys to select each digit from 0-9. Once you have the required digit press the **NEXT DIGIT** key. After selecting the fourth digit press **ENTER**.



If an incorrect PIN has been entered the following screen will be displayed. NOTE: this screen will also display if the PIN entered does not allow access to that functionality.



If a PIN number is entered that is already in use, the following screen will be displayed, press **CHANGE** to input an alternative PIN or **EXIT** to abort

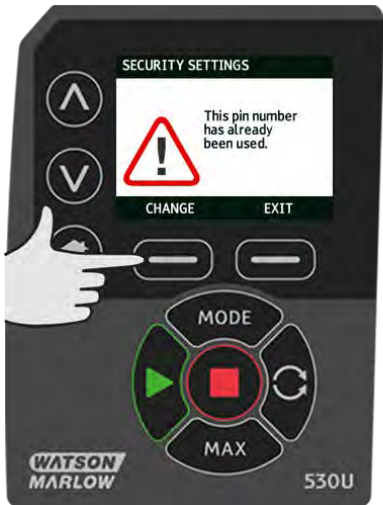

If the PIN entered does not allow access to the functionality the following screen will be displayed.



Keypad beep

From SECURITY settings scroll to Keypad beep using the \wedge / \vee keys and select **ENABLE**. The pump will now beep at every key press.



22.2 General settings

To view the general settings menu, select **GENERAL SETTINGS** from the main menu.

Auto restart

This pump offers an auto restart feature. If active on power loss, it restores the pump when power returns to the operating state it was in when power was lost.

For example, if the pump was running in analog mode prior to power loss, it would return to the same operating mode and continue to run at a proportional speed to the analog input.

Press **ENABLE/DISABLE** to turn the auto restart feature on/off.

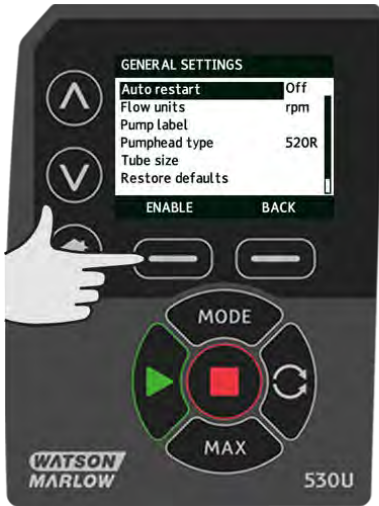

Do not use auto restart for more than 20 mains power starts per hour. We recommend remote control where a high number of starts is required.



Pump will start automatically if start conditions are met.

The ! icon is displayed on the home screens to indicate that the auto restart feature is active.



Flow units

The current chosen flow unit is displayed on the right hand side of the screen. To change flow units move the selection bar over the flow unit menu entry and press **SELECT**.

Use the ^/∨ keys to move the selection bar over the required flow unit, then press **SELECT**. All flow rates displayed on screens will now be in the chosen units.



If a mass flow unit is selected, the specific gravity of the fluid must be entered. The following screen is displayed.



Use the ^/v keys to enter the value of the specific gravity, and press **SELECT**.

Pump label

The pump label is a user defined 20 digit alphanumeric label which is displayed in the header bar of the home screen. To define or edit the pump label, move the selection bar over the Pump label menu entry and press **SELECT**. If a pump label has been previously defined, this will be displayed on screen to allow editing, otherwise it will display the default label "WATSON-MARLOW".

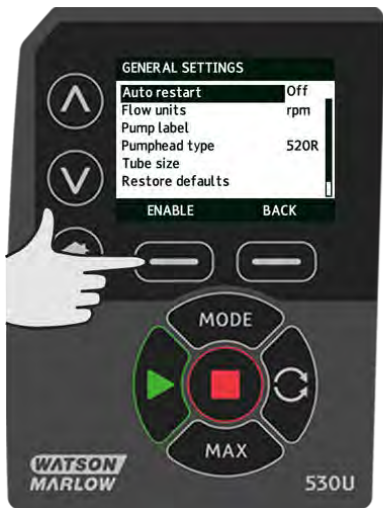

Use the ^/v keys to scroll through the available characters for each digit. The available characters are 0-9, A-Z and SPACE.

Press **NEXT** to move onto the next character, or **PREVIOUS** to move back to the previous character.



Press **FINISH** to save the entry and return to the general settings menu.



Pumphead type

Select GENERAL SETTINGS from the main menu.

Use the \wedge / \vee keys to move the selection bar over **Pumphead type** and press **SELECT**. The following screen will be displayed.

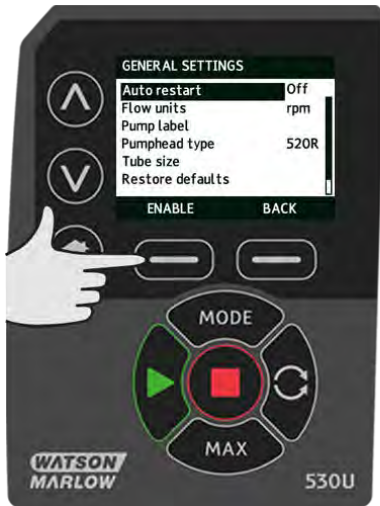

Use the \wedge / \vee keys to move the selection bar over **Pumphead** and press **SELECT**.

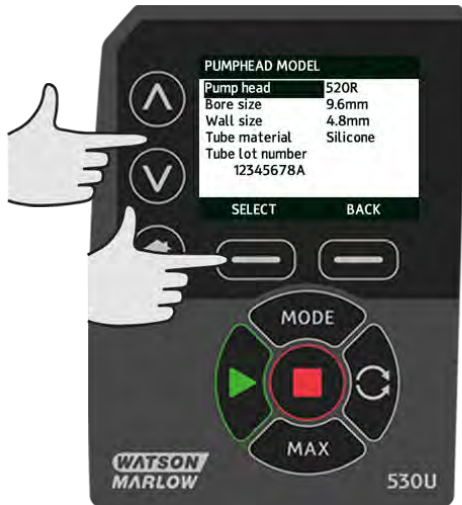

Use the \wedge / \vee keys to move the selection bar over the required pumphead type and press **SELECT**.



Tube size and tube material

Select **Tube size** from GENERAL SETTINGS, then use the \wedge / \vee keys to move the selection bar over **Bore size** and press **SELECT**.



Use the ^ / v keys to move the selection bar over the tube size to be used and press **SELECT**.



If a LoadSure element has been selected then the tube size is displayed as pressure and bore.



This screen also allows you to select the tube material used.

Use the \wedge / \vee keys to move the selection bar over **Tube material** and press **SELECT**.

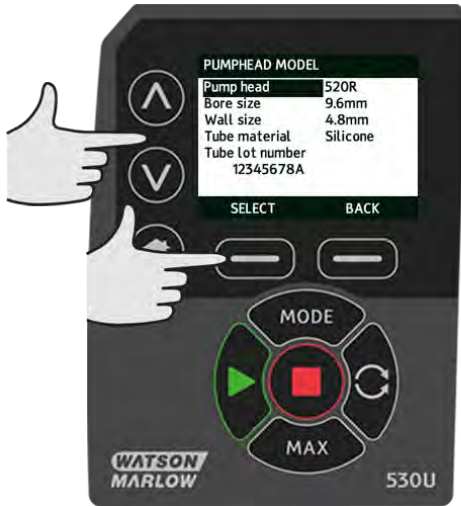

Use the \wedge / \vee keys to move the selection bar over the tube material to be used and press **SELECT**.



The PUMPHEAD MODEL screen allows the tube Lot Number to be recorded for future reference. Use the ^ /v keys to move the selection bar over **Tube lot number** and press **SELECT**.

Use the ^ /v keys to scroll through the available characters for each digit. The available characters are 0-9, A-Z, and SPACE.

Press **NEXT** to move onto the next character, or **PREVIOUS** to move back to the last character.



Press **FINISH** to save the entry and return to the general settings menu.

Restore defaults

To restore the factory default settings select **Restore defaults** from the general settings menu.

There are two confirmation screens to ensure that this function is not carried out in error.

Press **CONFIRM** followed by **RE-CONFIRM** to restore the defaults.



Language

Select language from the general settings menu to choose an alternative display language for the pump. The pump must be stopped before changing the language.

Use the \wedge / \vee keys to move the selection bar to your required language. Press **SELECT** to confirm.



Your selected language will now be displayed on screen. Press **CONFIRM** to continue, all displayed text will now appear in your chosen language.

Press **REJECT** to return to the language choice screen.



MODE menu

Selecting **MODE** menu from the main menu will navigate you to access the sub-menu shown below. This is the same as pressing the **MODE** key. Please see "Mode menu" on page 45 for further details.

22.3 Control settings

Select **CONTROL SETTINGS** from the main menu to access the sub menu shown below. Use the \wedge / \vee keys to move the selection bar. Press **SELECT** to choose the required function.



Speed limit

The maximum speed the pump is capable of running at is 220 rpm.

Select **Speed limit** from the control settings menu to define a lower maximum speed limit for the pump.

This speed limit will be applied to all operating modes.

Use the \wedge / \vee keys to adjust the value and press **SAVE** to set.

Applying a speed limit automatically re-scales the analog speed control response.

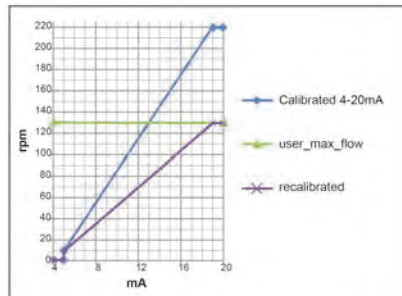
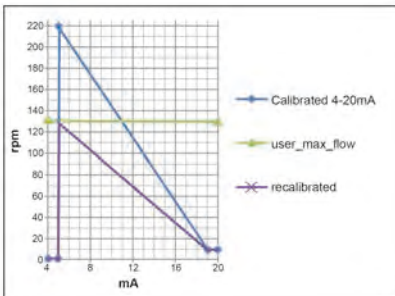

Reset run hours

Select **Reset run hours** from the control settings menu.

Select **RESET** to zero the run hours counter. The run hours counter can be viewed by pressing **INFO** from your home screen. The following screen will be displayed. Press **RESET** to reset the run hours or **CANCEL** to return to the CONTROL SETTINGS menu.



22.4 Configure outputs

Select **Configure outputs** from the CONTROL SETTINGS menu.

Use the \wedge / \vee keys and press **SELECT** to choose which output to configure.

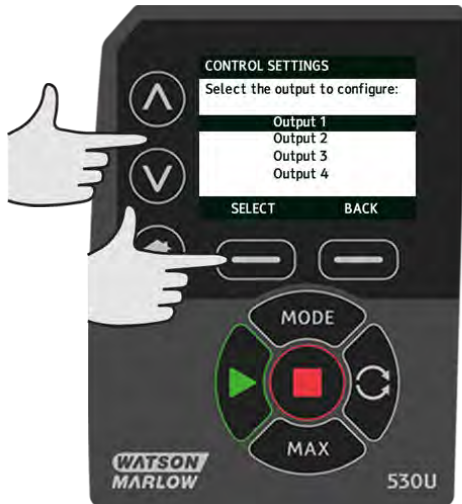

Use the \wedge / \vee keys and press **SELECT** to choose which pump status you require for the chosen output. The tick symbol indicates the current setting.



Use the \wedge / \vee keys and press **SELECT** to choose the logic state of the chosen output. Press **SELECT** to program the output or **BACK** to cancel.

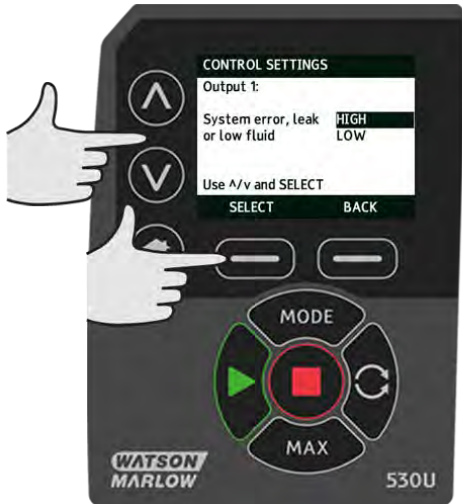

22.5 Configure inputs

Select **Configure inputs** from the CONTROL SETTINGS menu.

Use the \wedge / \vee keys and press **SELECT** to choose which input to configure.



Use the \wedge / \vee keys and press **SELECT** to choose the logic state of the chosen output.

Press **SELECT** to program the output or **BACK** to cancel.



NOTE: On this model, Inputs 4 and 5 are configured for a pressure sensor.

22.6 Help

Select Help from the main menu to access the help screens.

HELP AND ADVICE

See www.wmftg.com
for further information
and technical support.

Model:
530 Du
Tube reorder code:
933.0016.016

SOFTWARE

BACK

SOFTWARE VERSIONS

Main Processor Code:
1.2
HMI Processor Code:
1.2
HMI Screen Resources:
1.2
PROFIBUS Processor Code:
1.2

BOOTLOADER

BACK

BOOTLOADER VERSIONS

Main Processor Code:
1.2
HMI Processor Code:
1.2

BACK

23 Troubleshooting

If the pump display remains blank when the pump is switched on, make the following checks:

- Check that the mains power is available to the pump.
- Check the fuse in the wall plug if one is present.
- Check the position of the voltage selector switch.
- Check the mains power switch at the rear of the pump.
- Check the fuse in the fuse holder in the centre of the switch plate at the rear of the pump.

If the pump runs but there is little or no flow, make the following checks:

- Check that fluid is supplied to the pump.
- Check for any kinks or blockages in the lines.
- Check that any valves in the line are open.
- Check that the tube and rotor are in the pumphead.
- Check that the tube is not split or burst.
- Check that the correct wall-thickness tube is being used.
- Check the direction of rotation.
- Check that the rotor is not slipping on the drive shaft.

If the pump turns on, but will not run:

- Check the remote stop function and configuration.
- Check the mode you are in, are you in analog mode.
- Try to operate and run the pump in manual mode.

23.1 Leak detection

If a Watson-Marlow leak detector has been fitted to the pumphead, and a leak is detected; the pump will display the following message:



Follow the instructions in "Tube replacement" on page 109 to replace your tube or tubing element.

If this message is repeated when power is returned to the pump check that the leak detector is clean and free of debris and cycle the power to the pump.

Note: If this message is cleared by pressing the HOME key and reconfiguring the input, the leak input is now being ignored.

23.2 Error codes

If an internal error occurs, an error screen with a red background is displayed. Note: Signal out of range, over signal and leak detected error screens report the nature of an external condition. They do not flash.

Error code	Error condition	Suggested action
Er 0	FRAM write error	Attempt to reset by switching power OFF/ON. Or seek support.
Er 1	FRAM corruption	Attempt to reset by switching power OFF/ON. Or seek support.
Er 2	FLASH write error during drive update	Attempt to reset by switching power OFF/ON. Or seek support.
Er 3	FLASH corruption	Attempt to reset by switching power OFF/ON. Or seek support.
Er 4	FRAM shadow error	Attempt to reset by switching power OFF/ON. Or seek support.
Er 9	Motor stalled	Stop pump immediately. Check pumphead and tube. Power OFF/ON may reset. Or seek support.
Er10	Tacho fault	Stop pump immediately. Power OFF/ON may reset. Or seek support.
Er14	Speed error	Stop pump immediately. Power OFF/ON may reset. Or seek support.
Er15	Over current	Stop pump immediately. Power OFF/ON may reset. Or seek support.
Er16	Over voltage	Stop pump immediately. Check supply. Power OFF/ON may reset.
Er17	Under voltage	Stop pump immediately. Check supply. Power OFF/ON may reset.
Er19	Over temperature	Stop pump immediately. Turn OFF. Seek support.
Er20	Signal out of range	Check analog control signal range. Trim signal as required. Or seek support.
Er21	Over signal	Reduce the analog control signal.
Er30	Over power	Turn OFF. Check power supply. Check pumphead and tubing. Wait 30 minutes. Power ON may reset. Or seek support.
Err50	Communication error	Attempt to reset by switching power OFF/ON. Or seek support.

23.3 Technical support

Watson-Marlow Fluid Technology Group
Falmouth, Cornwall
TR11 4RU
UK
Telephone: +44 (0) 1326 370370
Fax: +44 (0) 1326 376009
Email: aftersales.uk@wmftg.com
www.wmftg.com

24 Drive maintenance

There are no user serviceable parts inside the pump. The unit should be returned to Watson-Marlow for service.

25 Drive spares

Description	Part No.
Replaceable main fuse, type T2, 2.5A H 250V 20mm	FS0064
Foot	MN2507M
Module seal	MN2516B
Module PCB(SCADA)	MNA2066A
Module PCB (NEMA)	MNA2069A
Module switch cover	MN2505M
Glands (STD)	GR0056
Glands (EMC)	GR0075
Blanking plugs	GR0057
Sealing washer for blanking plug and gland	GR0058
Snap-fit vent	MN2513B

26 Pumphead replacement



Always isolate the pump from the mains power supply before opening any guard or track, or performing any positioning, removal or maintenance operation.

26.1 Pumphead replacement

520R

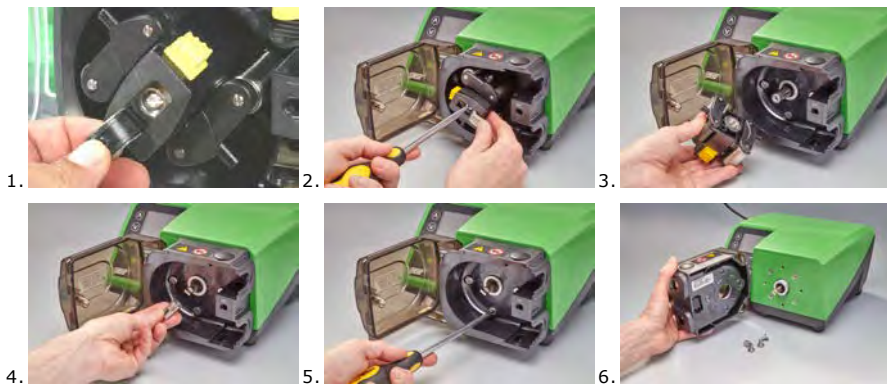

27 Tube replacement



Always isolate the pump from the mains power supply before opening any guard or track, or performing any positioning, removal or maintenance operation.

27.1 Continuous tubing

520R and 520R2

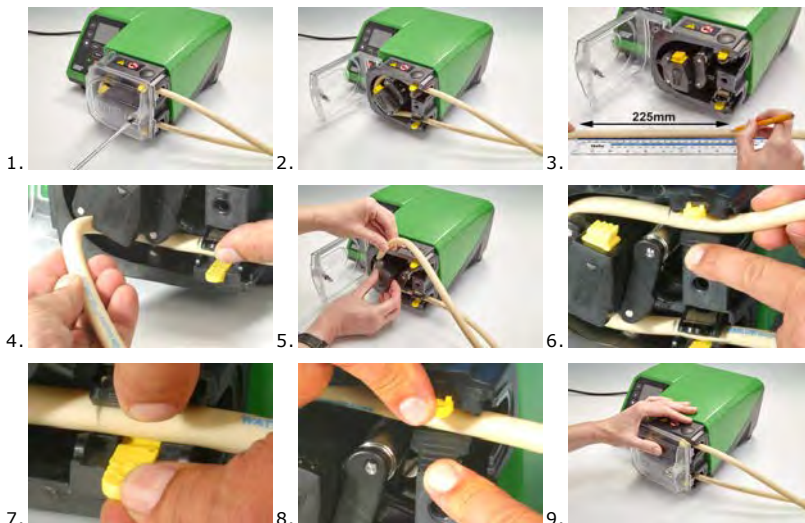

505L

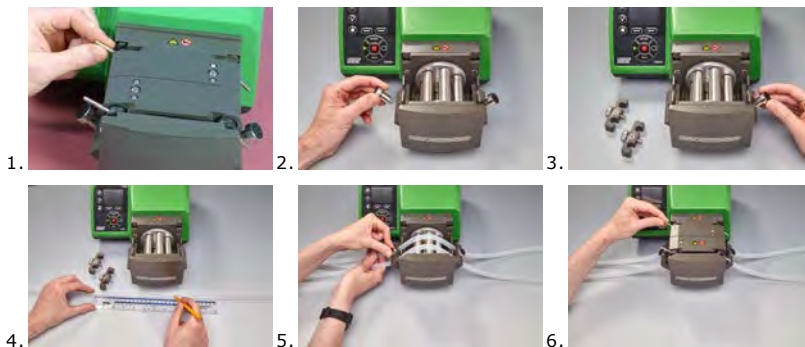

$\leq 8.0\text{mm} = 145\text{mm}$,
 $9.6\text{mm} = 150\text{mm}$

27.2 Tube elements



520REL, 520REM and 520REH

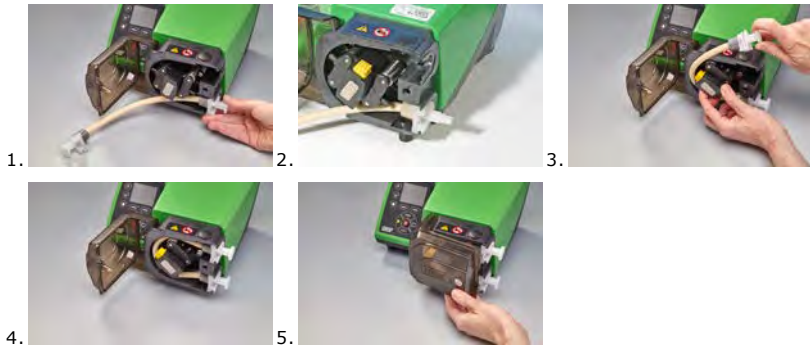

Sanitary connectors



Industrial connectors



505L

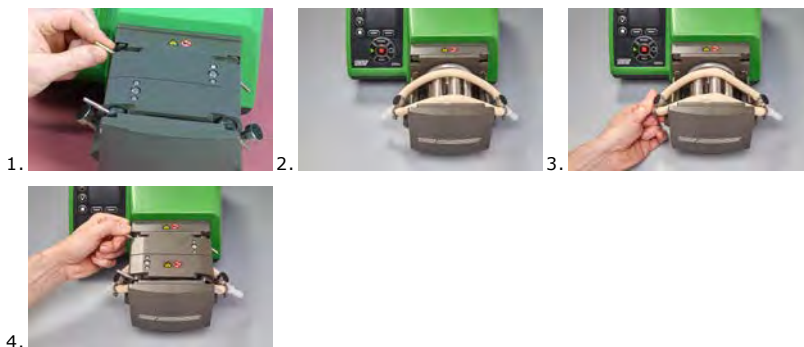

General guide to cleaning with solvents

Chemical	Cleaning precautions
Aliphatic hydrocarbons	Remove guard. Minimize rotor cap and clutch boot exposure to less than one minute (risk of attack).
Aromatic hydrocarbons	Remove guard. Minimize rotor cap and clutch boot exposure to less than one minute (risk of attack).
Ketone solvents	Remove guard. Minimize rotor cap and clutch boot exposure to less than one minute (risk of attack).
Halogenated/chlorinated solvents	Not recommended: possible risk to polycarbonate tube clamp adjusters and polypropylene tube clamp locators.
Alcohols, general	No precaution necessary.
Glycols	Minimize rotor cap and clutch boot exposure to less than one minute (risk of attack).
Estersolvents	Remove guard. Minimize rotor cap and tube clamp location cap exposure to less than one minute (risk of attack).
Ether solvents	Not recommended: possible risk to polycarbonate tube clamp adjusters and polypropylene tube clamp locators.



28.2 Tubing and element part numbers

1.6mm wall tubing for 520R pumphheads

					
mm	inch	#	Marprene	Bioprene	Sta-Pure PFL
0.5	1/50	112	902.0005.016	933.0005.016	—
0.8	1/32	13	902.0008.016	933.0008.016	—
1.6	1/16	14	902.0016.016	933.0016.016	965.0016.016
3.2	1/8	16	902.0032.016	933.0032.016	965.0032.016
4.8	3/16	25	902.0048.016	933.0048.016	965.0048.016
6.4	1/4	17	902.0064.016	933.0064.016	965.0064.016
8.0	5/16	18	902.0080.016	933.0080.016	965.0080.016
mm	inch	#	PVC	Fluorel	Neoprene
0.8	1/32	13	—	—	920.0008.016
1.6	1/16	14	950.0016.016	970.0016.016	920.0016.016
3.2	1/8	16	950.0032.016	970.0032.016	920.0032.016
4.8	3/16	25	950.0048.016	970.0048.016	920.0048.016
6.4	1/4	17	950.0064.016	970.0064.016	920.0064.016
8.0	5/16	18	950.0080.016	970.0080.016	920.0080.016
mm	inch	#	Pumpsil	Sta-Pure PCS	
0.5	1/50	112	913.A005.016	—	
0.8	1/32	13	913.A008.016	—	
1.6	1/16	14	913.A016.016	960.0016.016	
3.2	1/8	16	913.A032.016	960.0032.016	
4.8	3/16	25	913.A048.016	960.0048.016	
6.4	1/4	17	913.A064.016	960.0064.016	
8.0	5/16	18	913.A080.016	960.0080.016	

Note: 1.6mm wall Chem-Sure and Sta-Pure tubing are supplied in 305mm lengths.

2.4mm wall tubing for 520R2 pumpheads

					
mm	inch	#	Marprene	Bioprene	Pumpsil
0.5	1/50	—	—	—	913.A005.024
0.8	1/32	—	—	—	913.A008.024
1.6	1/16	119	902.0016.024	903.0016.024	913.A016.024
3.2	1/8	120	902.0032.024	903.0032.024	913.A032.024
4.8	3/16	15	902.0048.024	903.0048.024	913.A048.024
6.4	1/4	24	902.0064.024	903.0064.024	913.A064.024
8.0	5/16	121	902.0080.024	903.0080.024	913.A080.024
9.6	3/8	122	902.0096.024	903.0096.024	913.A096.024
mm	inch	#	Chem-Sure	Sta-Pure	
0.8	1/32	—	—	—	
1.6	1/16	119	965.0016.024	960.0016.024	
3.2	1/8	120	965.0032.024	960.0032.024	
4.8	3/16	15	965.0048.024	960.0048.024	
6.4	1/4	24	965.0064.024	960.0064.024	
8.0	5/16	121	965.0080.024	960.0080.024	

Note: 2.4mm wall Chem-Sure and Sta-Pure tubing are supplied in 355mm lengths.

2.4mm wall elements for 520RE pumpheads

0-2 bar (0-30 psi) pressure rated elements						
Industrial						
mm	inch	#	Marprene TL	Pumpsil	Neoprene	Chem-Sure
3.2	1/8	16	902.0032.PFQ	913.A032.PFQ	920.0032.PFQ	965.0032.PFQ
6.4	1/4	17	902.0064.PFQ	913.A064.PFQ	920.0064.PFQ	965.0064.PFQ
9.6	3/8	122	902.0096.PFQ	913.A096.PFQ	920.0096.PFQ	965.0096.PFQ
Sanitary						
mm	inch	#	Bioprene TL	Pumpsil	Sta-Pure	Chem-Sure
3.2	1/8	16	903.0032.PFT	913.A032.PFT	920.0032.PFT	965.0032.PFT
6.4	1/4	17	903.0064.PFT	913.A064.PFT	920.0064.PFT	965.0064.PFT
9.6	3/8	122	903.0096.PFT	913.A096.PFT	920.0096.PFT	965.0096.PFT

2-4 bar (30-60 psi) pressure rated elements				
Industrial				
mm	inch	#	Marprene TM	Chem-Sure
3.2	1/8	16	902.P032.PFQ	965.M032.PFQ
6.4	1/4	17	902.P064.PFQ	965.M064.PFQ
Sanitary				
mm	inch	#	Bioprene TM	Sta-Pure
3.2	1/8	16	903.P032.PFT	960.M032.PFT
6.4	1/4	17	903.P064.PFT	960.M064.PFT

4-7 bar (60-100 psi) pressure rated elements

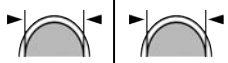

Industrial

mm	inch	#	Marprene TM	Sta-Pure
3.2	1/8	16	902.H032.PFQ	960.H032.PFQ

Sanitary

mm	inch	#	Bioprene TM	Sta-Pure
3.2	1/8	16	903.H032.PFT	960.H032.PFT

28.3 Pumphead spares

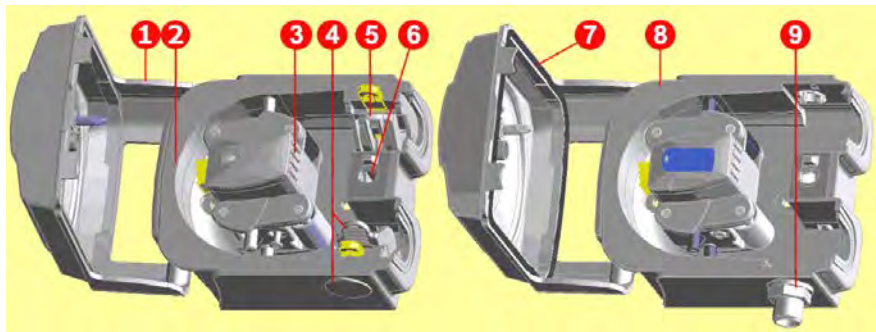

	520R/520R2	520REL/520REM/520REH
	053.1011.100	520R
	053.1011.2L0	520R2
	053.1011.EL0	520REL
	053.1011.EM0	520REM
	053.1011.EH0	520REH
1	MNA2050A (520R, 520R2)	Pumphead guard complete with tool-unlockable latch
2	MNA2045A (520R, 520R2)	Track assembly for cased pumps complete with spring-loaded tube clamps
3	MNA2043A (520R - 1.6mm wall tube) MNA2001 (520R2 - 2.4mm wall tube) MNA2138A (grey) (520REL) MNA2139A (beige) (520REM) MNA2140A (blue) (520REH)	Rotor assembly complete with pumping rollers, follower rollers and tube guide rollers
4	MNA2006A (520R, 520R2) MN2002M (520R, 520R2) MN2131M (520RE)	Bottom (LH) tube clamp Tube clamp location plug Drain plug
5	MNA2005A (520R, 520R2) MN2002M (520R, 520R2)	Top (RH) tube clamp Tube clamp location plug
6	MN2034B MN2005M	Guard latch spring Guard latch spring cartridge
7	MNA2147A (520RE)	Pumphead guard complete with seal and tool-lockable latch

	520R/520R2	520REL/520REM/520REH
8	MNA2144A (520RE)	Track assembly for cased pumps
9	MN2023T and MN2003T (520RE)	Drain port and nut

Parts may be ordered individually.

28.4 Pumping accessories

Accessory	Description	Part code	Pump compatibility
520ANC	Network cable, RS232, with 9-pin D-connectors	059.3121.000	530Du, 530Di
520ANX	Network extension cable with 9-pin D-connectors	059.3122.000	530Du, 530Di
520ANA	Network adaptor, 25-pin to 9-pin D-connectors	059.3123.000	
520AB	Batch records cable with 9-pin D-connectors	059.3125.000	530Di
520AF	Foot switch with 25-pin D-connector	059.3002.000	530U, 530Du, 530Di
520AH	Hand switch with 25-pin D-connector	059.3022.000	530U, 530Du, 530Di
505LTC	Tube clamp set for 505L pumphead	059.4001.000	530Di
505AS	Filling stand	059.5001.000	All models
520AL	Dispensing lance for use with 520AFN filling needles	059.5052.000	All models
505AFN	Filling needle set	059.5101.000	All models
	Filling needle 1.6mm bore	059.5100.016	All models
	Filling needle 3.2mm bore	059.5100.032	All models
	Filling needle 4.8mm bore	059.5100.048	All models
	Filling needle 6.4mm bore	059.5100.064	All models
	Filling needle 8.0mm bore	059.5100.080	All models
	Tube monitor with 25-pin D-connector	059.4501.520	530U, 530Du, 530Di
	Tube monitor, bare lead	059.450N.520	530UN, 530DuN, 530DiN
520AD	Leak detector kit	059.8121.000	530U, 530Du, 530Di

Accessory	Description	Part code	Pump compatibility
520AD	Leak detector kit	059.8131.000	530UN, 530DuN, 530DiN

29 Performance data

29.1 Performance curves

Flow rates of suction and discharge pressures for the pumphead at different drive speeds.

This data was produced pumping water at ambient temperature.

Marpene continuous tubing, 1.6mm wall, 200rpm, clockwise rotation

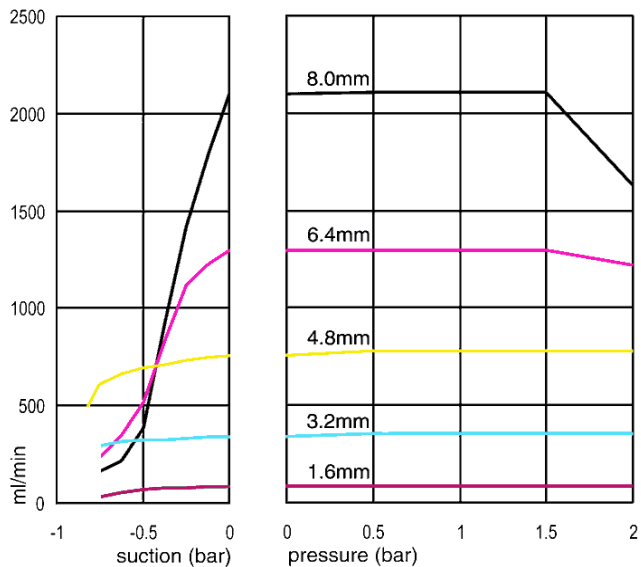

Marpene continuous tubing, 1.6mm wall, 200rpm, counter-clockwise rotation

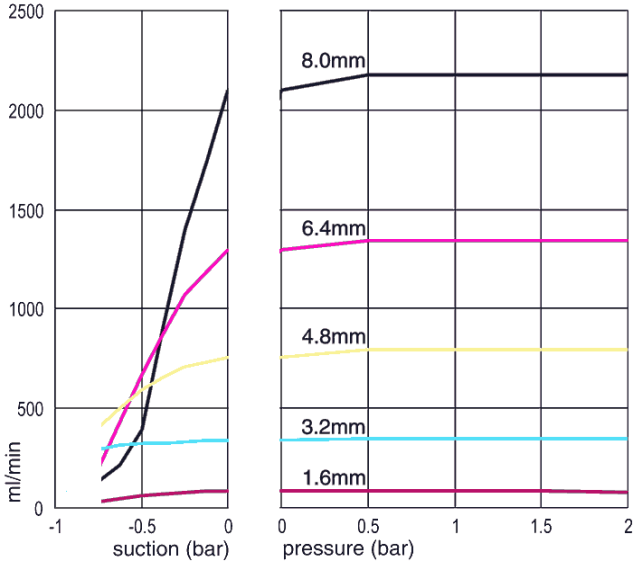

Marpene continuous tubing, 2.4mm wall, 200rpm, clockwise rotation

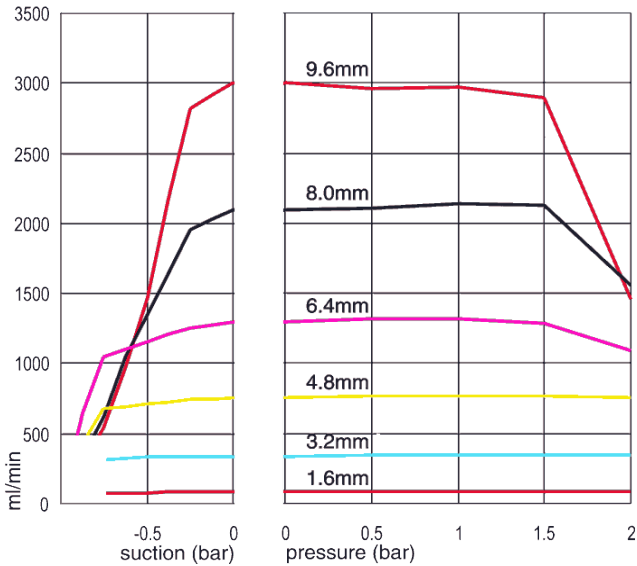

Marpene continuous tubing, 2.4mm wall, 200rpm, counter-clockwise rotation

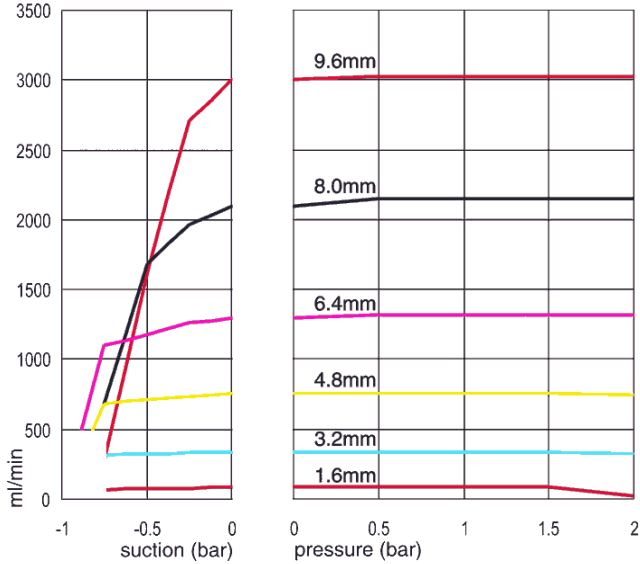

Marpene TL element, 0-2 bar (0-30psi), 200rpm, counter-clockwise rotation

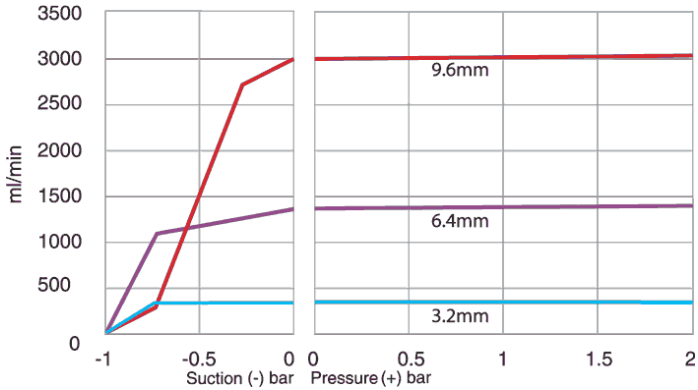

Sta-Pure element, 0-2 bar (0-30psi), 200rpm, counter-clockwise rotation

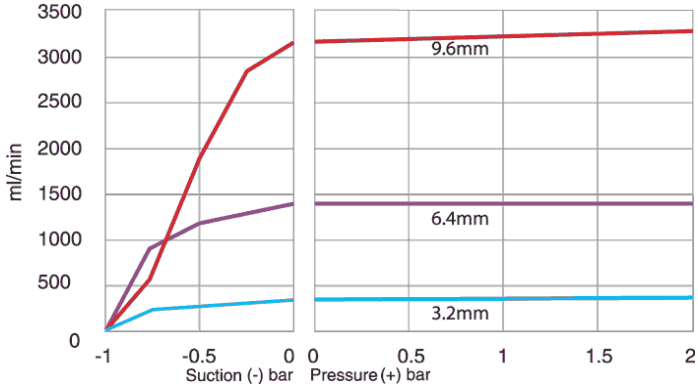

Marprene TM element, 2-4 bar (20-60psi), 200rpm, counter-clockwise rotation

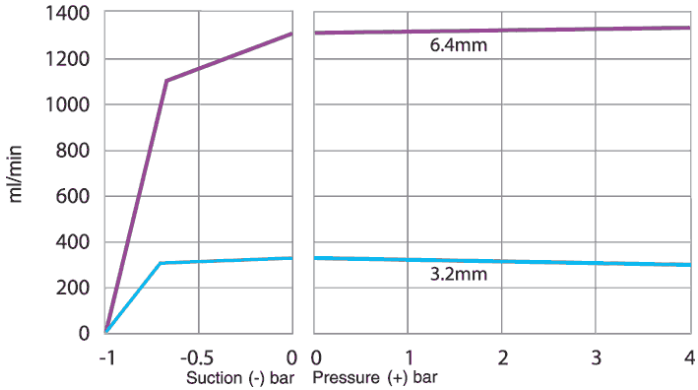

Sta-Pure element, 2-4 bar (30-60psi), 200rpm, counter-clockwise rotation

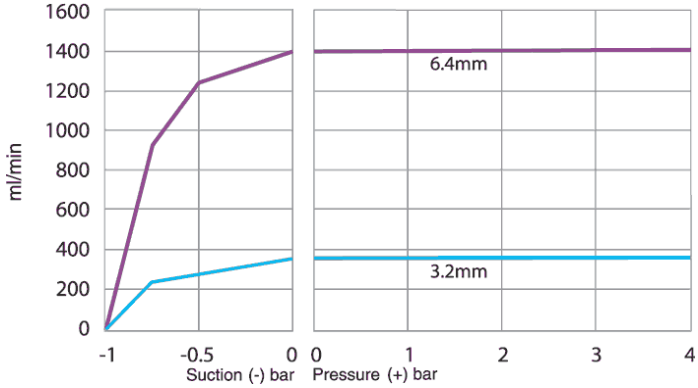

Marprene TH element, 4-7 bar(60-100psi), 200rpm, counter-clockwise rotation

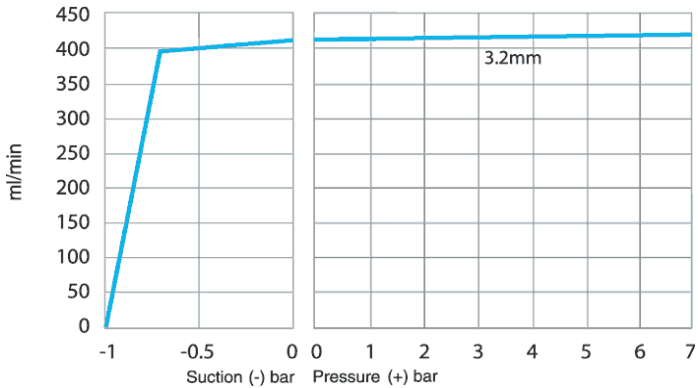

30 Trademarks

Watson-Marlow, Bioprene, Pumpsil, LoadSure and Marprene are trademarks of Watson-Marlow Limited.

Fluorel is a trademark of 3M.

Sta-Pure PCS and Sta-Pure PFL are trademarks of W.L.Gore and Associates.

31 Disclaimers

The information contained in this document is believed to be correct but Watson-Marlow Fluid Technology Group accepts no liability for any errors it contains and reserves the right to alter specifications without notice.

WARNING: This product is not designed for use in and should not be used for, patient-connected applications.

32 Publication history

m-530dun-gb-01 530 Du/DuN pump

First published 12.15