



SERVICE MANUAL

Commercial Disposers

- SS-50
- SS-75
- SS-100
- SS-125
- SS-150
- SS-200
- SS-300
- SS-500
- SS-750
- SS-1000



TABLE OF CONTENTS

GENERAL INFORMATION 3

 SAFETY SIGNALS 3

 COMMERCIAL DISPOSERS 3

 PRIOR TO SERVICE CALL 3

 AFTER COMPLETING SERVICE 3

 COMMERCIAL DISPOSER PARTS LIMITED WARRANTY 4

 SERIAL NUMBER DATE CODE 4

SPECIFICATIONS 5

 COLD WATER FLOW & DRAIN LINE DIAMETER 5

 DIMENSIONS 5

 ELECTRICAL REQUIREMENTS 7

 RECOMMENDED INSTALLATION 8

 REMOVING DISPOSER 9

 INSTALLING DISPOSER 9

PREPARATION FOR REPAIR 9

 COMMON REPAIR AREAS 10

 TERMINAL BOX & TRIM BAND 11

GRINDING CHAMBER 12

 REPLACING WATER INLET 12

 REPLACING SHREDDER GASKET 12

 REPLACING STATIONARY SHREDDER 13

 REPLACING ROTATING SHREDDER 14

 REPAIRING UPPER END BELL ASSEMBLY 15

UPPER END BELL (UEB) 15

ELECTRICAL REPAIRS 18

 OVERLOAD PROTECTOR 18

 CAPACITOR 19

 BOTTOM COVER AND FAN 20

 LOWER END FRAME (LEF) 21

 REPLACING START SWITCH (1 PHASE MODELS) 21

 STATOR 22

 MOTOR LEADS CONNECTIONS 23

WIRING DIAGRAMS 24

TROUBLESHOOTING 27

EXPLODED VIEWS & PARTS LISTS 32

GENERAL INFORMATION

Safety Signals

This symbol indicates potential personal injury hazards. Obey all safety messages accompanying this symbol to avoid possible injury or death.

DANGER indicates an imminently hazardous situation which, if not avoided, **will** result in death or serious injury.

WARNING indicates a potentially hazardous situation which, if not avoided, **could** result in death or serious injury.

CAUTION indicates a potentially hazardous situation which, if not avoided, **may** result in minor or moderate injury.

Commercial Disposers

InSinkErator® manufactures commercial food waste disposers with motors ranging from 1/2 horsepower through 10 horsepower.

The basic assembly of all SS Series commercial disposers is identical. However, electrical connections vary depending upon the disposer specifications, power supply, and electrical controls.

Specification Decal

The specification decal (Figure 1) located on the motor trim cover indicates

- complete model number (example - SS150-24)
- serial number (includes manufactured date)
- amperage
- voltage
- phase
- horsepower.

NOTE: The correct part sheet (as designated by the complete model number) must be referenced to order replacement parts.

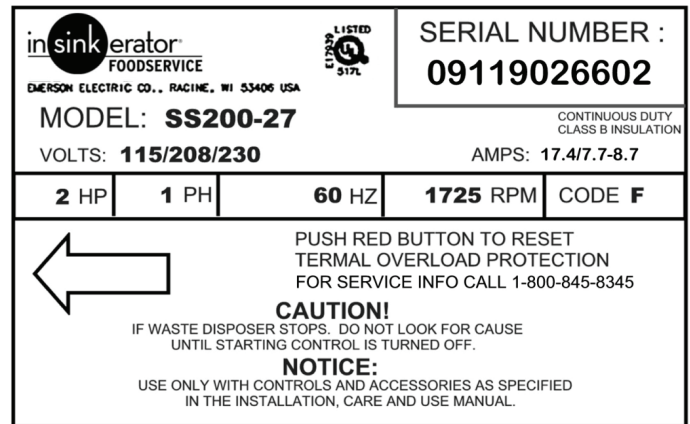

Figure 1. Specification Decal

Prior to Service Call

- Obtain the model number, serial number, voltage and phase from the customer to prepare for the service call.
- Date of installation.
- Obtain the service history of the disposer.
- Make sure the customer has tried resetting the overload protector and has checked for foreign objects jammed in the grind chamber (see “Troubleshooting” on page 25).
- Before troubleshooting for mechanical problems, determine if the problem is electrical:
 - To determine if the problem is in the switch or the disposer, bypass all electrical starting and/or electrical controls and run the disposer direct.
 - Make sure the disposer electrical specifications match the electric power supply.
 - Make sure the motor lead connections are correct for the corresponding power supply and starting controls.
 - Determine if there are electrical problems with other kitchen appliances. This may indicate a problem in the building’s electrical circuitry.

After Completing Service

Test the disposer for proper operation and ensure that the fittings are secure and do not leak.

SPECIFICATIONS

Cold Water Flow & Drain Line Diameter

Disposer	Water Flow GPM (LPM)	Drain Line Diameter Inches (MM)
SS-50	3 (11)	1-1/2" (38)
SS-75	3 (11)	1-1/2" (38)
SS-100	5 (19)	1-1/2" (38)
SS-125	5 (19)	1-1/2" (38)
SS-150	7 (26)	2" NPT (51)
SS-200	7 (26)	2" NPT (51)
SS-300	8 (30)	3" NPT (51)
SS-500	8 (30)	3" NPT (51)
SS-750	10 (38)	3" NPT (51)
SS-1000	10 (38)	3" NPT (51)

Dimensions

IMPORTANT: Use the following dimension charts for adaptor height in place of InSinkEerator sink bowl height when mounting directly to a sink. *Dimensions - Models SS-50, SS-75, SS-100 & SS-125.*

Sink Bowl	Flange O.D. X	Work Table Hole Y	Flange I.D. Z	Height
12" (304.8 mm)	13-1/2" (342.9 mm)	12-1/4" (311.2 mm)	12" (304.8 mm)	6-1/2" (165.1 mm)
15" (381 mm)	16-1/2" (419.1 mm)	15-1/4" (387.4 mm)	15" (381.0 mm)	6-1/2" (165.1 mm)
18" (457.2 mm)	19-1/2" (495.3 mm)	18-1/4" (463.6 mm)	18" (457.2 mm)	6-1/2" (165.1 mm)
Adaptors	X	Y	Z	Height
No. 5*	Fits Standard Sink Opening: 3-1/2" - 4" (88.9 mm - 101.6 mm)			2-3/4" (69.9 mm)
No. 6	7-13/16" (198.4 mm)	6-7/8" (174.6 mm)	6-5/8" (168.3 mm)	1-3/16" (30.7 mm)
No. 7	9-1/8" (231.8 mm)	7-7/8" (200.0 mm)	7-5/8" (193.7 mm)	2-1/16" (52.4 mm)

NOTE:

- Adaptors are available upon request for all competitor sink bowls or cones.
- Please have sink/bowl cone type with the necessary dimensions when ordering adaptors.

* It is recommended to add legs (Part No. 11757C) with No. 5 Mounting Assembly.

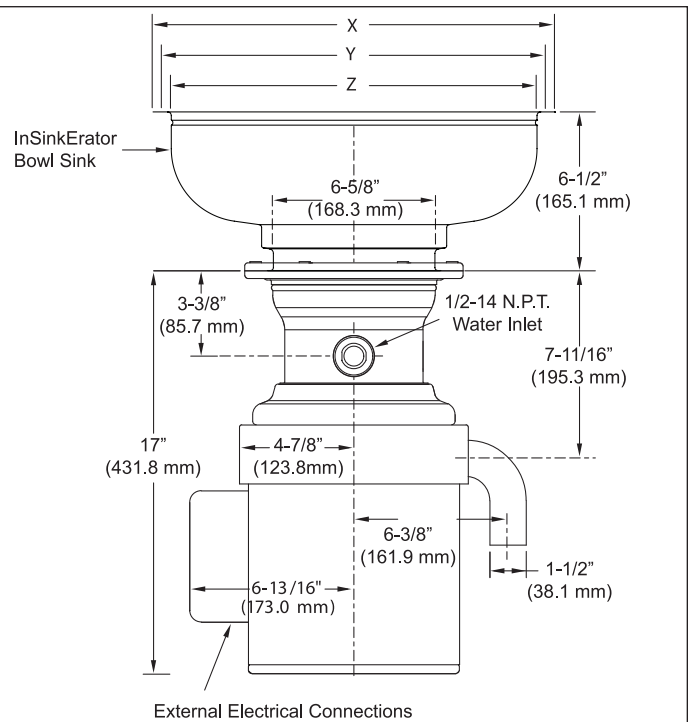

Figure 2. Dimensions - Models SS-50, SS-75, SS-100 & SS-125

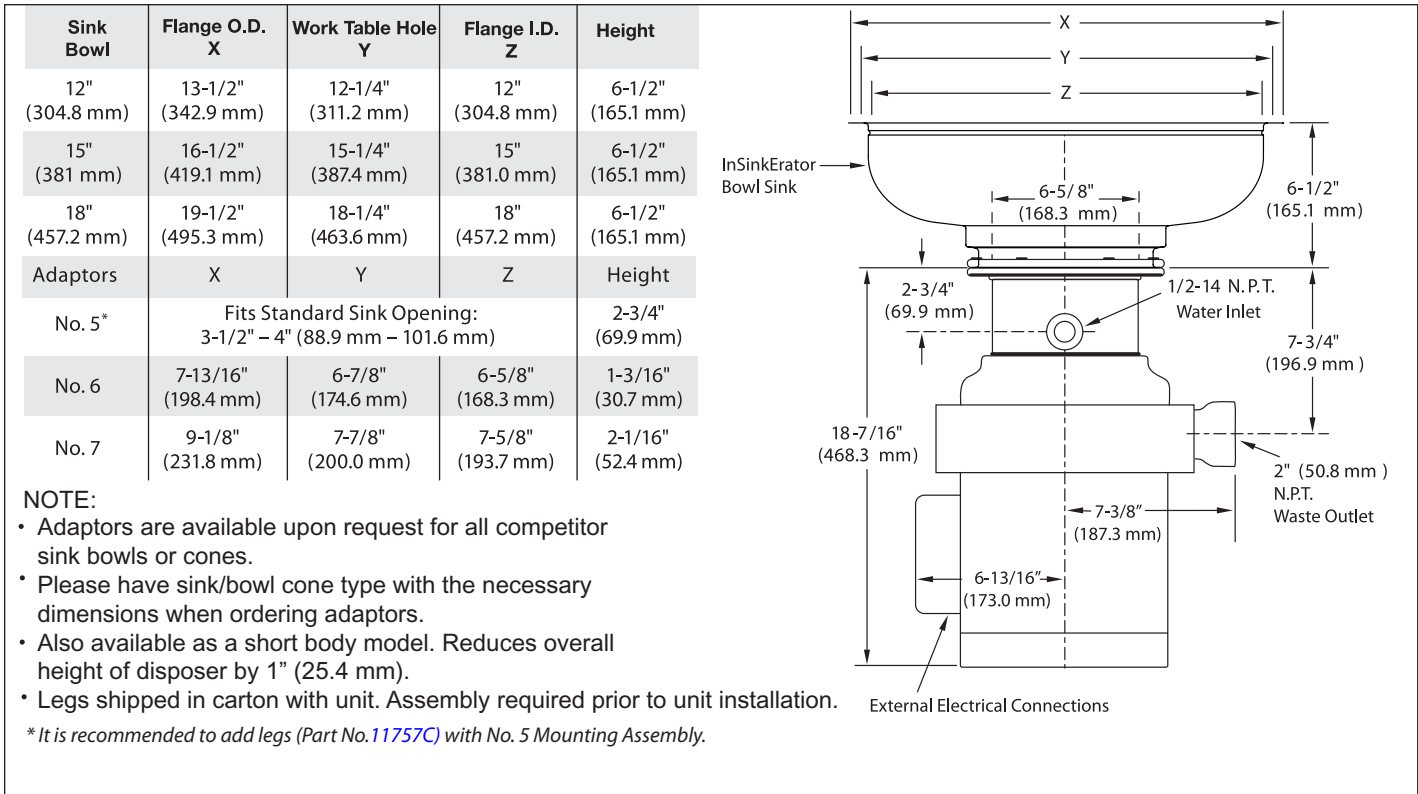

Figure 3. Dimensions - Models SS-150 & SS-200

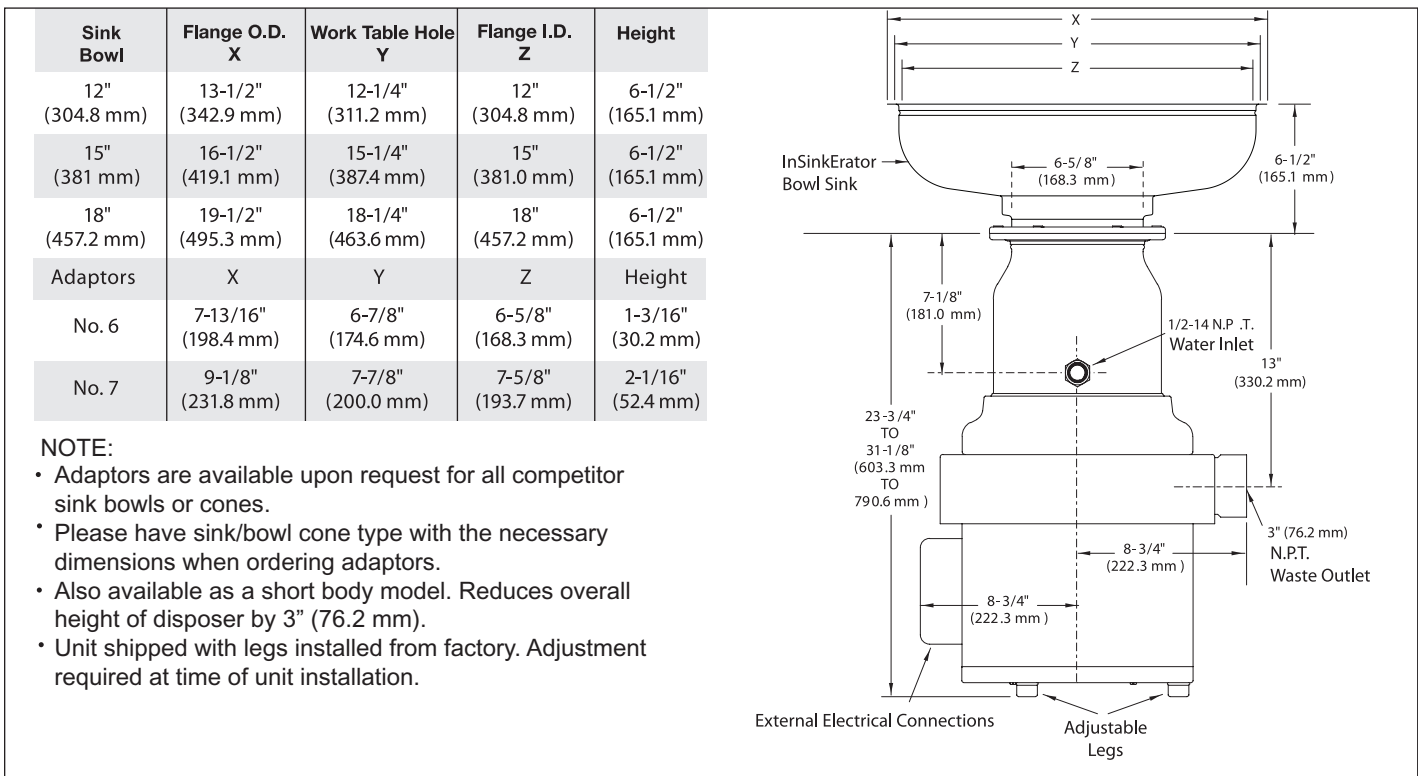

Figure 4. Dimensions - Models SS-300, SS-500, SS-750 & SS1000

Electrical Requirements

The electrical wiring on disposers shipped from the factory are not connected for a specific voltage. Refer to the Standard Motor Connection Wiring Diagram attached to the inside of the disposer terminal box cover for the correct voltage connections.

Standard disposer voltages are:

- 115/208/230 volts for single phase electrical power
- 208/230/460 volts for three phase electrical power

NOTE: All amp ratings denote amp draw during a grind load.

NOTE: The disposer motor phase and voltage must be the same as the line or power supply.



ELECTRIC SHOCK! The disposer must be permanently grounded.

SS-50 1/2 H.P.	-26	115/208-230V, 60Hz, 1 Ph, 8.4/4.0/4.2 amps, UL
	-27	208-230/460V, 60Hz, 3 Ph, 2.0/2.1/1.1 amps, UL
	-28	115/208-230V, 60Hz, 1 Ph, 8.4/4.0/4.2 amps, CSA
	-29	208-230/460V, 60Hz, 3 Ph, 2.0/2.1/1.1 amps, CSA
SS-75 3/4 HP	-27	115/208-230V, 60Hz, 1 Ph, 10.0/4.3/5.0 amps, UL
	-28	208-230/460V, 60Hz, 3 Ph, 2.0/2.4/1.2 amps, UL
	-29	115/208-230V, 60Hz, 1 Ph, 10.4/4.3/5.0 amps, CSA
	-30	208-230/460V, 60Hz, 3 Ph, 2.0/2.4/1.2 amps, CSA
SS-100 1 H.P.	-28	115/208-230V, 60Hz, 1 Ph, 11.6/5.1/5.7 amps, UL
	-29	208-230/460V, 60Hz, 3 Ph, 2.2/3.0/1.5 amps, UL
	-30	115/208-230V, 60Hz, 3 Ph, 11.6/5.1/5.7 amps, CSA
	-31	208-230/460V, 60Hz, 3 Ph, 2.2/3.0/1.5 amps, CSA
SS-125 1-1/4 H.P.	-25	115/208-230V, 60Hz, 1 Ph, 10.6/4.5/5.3 amps, UL
	-26	208-230/460V, 60Hz, 3 Ph, 3.5/4.0/2.0 amps, UL
	-27	15/208-230V, 60Hz, 1 Ph, 10.6/4.5/5.3 amps, CSA
	-28	208-230/460V, 60Hz, 3 Ph, 3.5/4.0/2.0 amps, CSA
SS-150 1-1/2 H.P.	-34	115/208-230V, 60Hz, 1 Ph, 12.2/5.7/6.1, amps, UL
	-36	208-230/460V, 60 Hz, 3 Ph, 3.2/4.6/2.3 amps, UL
	-37	208-230/460V, 60 Hz, 3 Ph, 3.2/4.6/2.3 amps, CSA
	-38	115/208-230V,, 60 Hz, 1 Ph, 12.2/5.7/6.1 amps, UL , short body
	-39	208-230/460V, 60 Hz, 3 Ph, 3.2/4.6/2.3 amps, UL , short body
	-35	115/208-230V, 60 Hz, 1 Ph, 12.2/5.7/6.1 amps, CSA
SS-200 2 H.P.	-27	115/208-230V, 60 Hz, 1 Ph, 17.4/7.7/8.7 amps, UL
	-29	208-230/460V, 60 Hz, 3 Ph, 3.3/5.0/2.5 amps UL
	-31	115/208-230V, 60 Hz, 1 Ph, 17.4/7.7/8.7 amps, UL , short body
	-32	208-230/460V, 60 Hz, 3 Ph, 3.3/5.0/2.5 amps, UL , short body
	-28	115/208-230, 60 Hz, 1 Ph, 17.4/7.7/8.7 amps, CSA
	-30	208-240/460V 60Hz, 3 Ph, 3.3/5.0/2.5 amps, CSA
SS-300 3 H.P.	-25	208-230/460V, 60 Hz, 3 Ph, 6.0/7.4/3.7 amps, UL
	-27	208-230/460V, 60 Hz, 3 Ph, 6.0/7.4/3.7 amps, UL , short body
	-26	208-230/460V, 60 Hz, 3 Ph, 6.0/7.4/3.7 amps, CSA
SS-500 5 H.P.	-28	208-230/460V, 60 Hz, 3 Ph, 8.4/8.8/4.4 amps, UL
	-30	208-230/460V, 60 Hz, 3 Ph, 8.4/8.8/4.4 amps, UL , short body
	-29	208-230/460V, 60 Hz, 3 Ph, 8.4/8.8/4.4 amps, CSA

SS-750 7-1/2 H.P.	-13	208-230/460V, 60 Hz, 3 Ph, 9.7/12.4/6.2 amps, UL
	-15	208-230/460V, 60 Hz, 3 Ph, 9.7/12.4/6.2 amps, UL , short body
	-14	208-230/460V, 60 Hz, 3 Ph, 9.7/12.4/6.2 amps, CSA
SS-1000 10 H.P.	-10	208-230/460V, 60 Hz, 3 Ph, 11.0/13.0/6.5 amps, UL
	-12	208-230/460V, 60 Hz, 3 Ph, 11.0/13.0/6.5 amps, UL , short body
	-11	208-230/460V, 60 Hz, 3 Ph, 11.0/13.0/6.5 amps, CSA

Recommended Installation

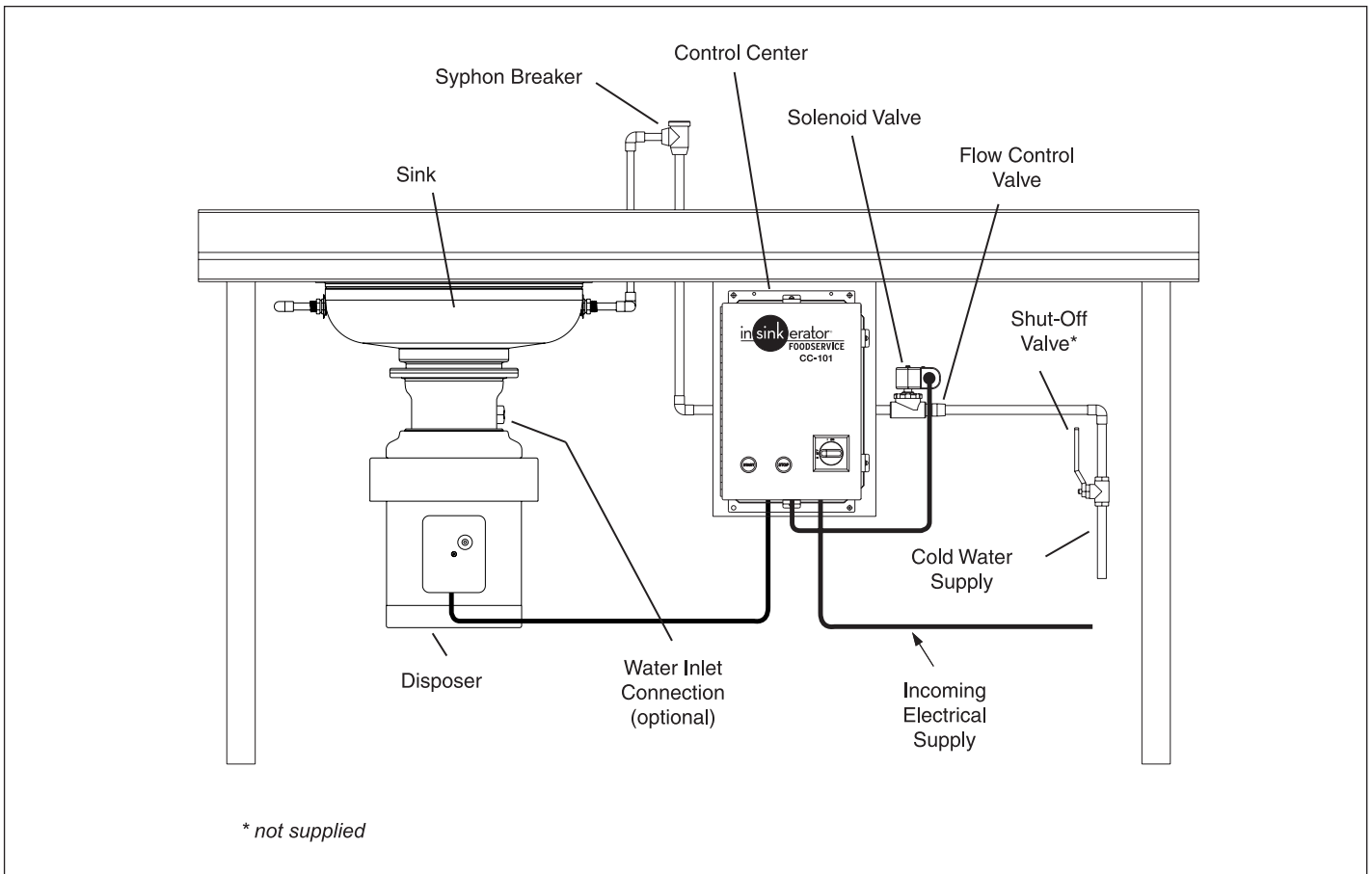

Figure 5. Recommended Installation

PREPARATION FOR REPAIR

⚠ DANGER

ELECTRIC SHOCK! Turn off water and electrical supply. Discharge capacitor with 1000 ohm jumper wire (1 Phase only). Do not use a screwdriver to discharge or capacitor may be damaged.



Removing Disposer

1. Turn off electrical supply and water supply to disposer.
2. Disconnect cold water connection from disposer body water inlet (if connected).
3. Disconnect waste line from disposer.
4. Remove terminal box retaining screw and terminal box cover. See "Terminal Box & Trim Band" on page 9. Mark motor lead wires and electrical supply wires, then disconnect wires and grounding wire from disposer.

NOTE: Make sure sink can bear weight of disposer before legs are loosened. In some cases, support disposer before loosening or removing legs.

5. If equipped with legs and legs interfere with removing disposer from mounting flange, pull O-ring down disposer leg, turn each leg clockwise to raise legs and gain floor clearance.
6. Remove disposer from mounting flange by turning disposer or loosening bolts as necessary (depending on mounting flange).
7. To remove legs, remove black cap plug from bottom of support leg (Figure 6). Insert slotted screwdriver into open end of leg support tube and turn stud counterclockwise until free of upper end bell. Pull leg from disposer.

Installing Disposer

⚠ DANGER

ELECTRIC SHOCK! Turn off water and electrical supply. Discharge capacitor with jumper wire (1 Phase only).

1. If unit was equipped with legs, insert leg assemblies through end cover guide holes. Insert screwdriver into open end of leg support tube and turn stud clockwise to install. Install O-ring, washer and cap to each leg (Figure 6).

NOTE: On models SS-150 thru SS-200, legs are optional and recommended where the disposer is mounted to a thin gauge sink (16 gauge minimum), dish table, using a #5 mounting assembly or non-InSinkErator mounting adaptors. On models SS-300 and above, legs are factory installed and recessed on the unit.

2. Attach disposer to the mounting assembly by positioning in mounting flange and turning disposer into flange or tightening bolts (depending on specific mounting).
3. Adjust legs so unit is supported evenly. Push O-ring up flush with bottom of unit.

4. Connect electrical supply wires to the motor leads. Reference the wiring diagram attached to the inside of the terminal box or the *Wiring Diagrams* section of the Disposer Control Center Installation manual.
5. Reinstall terminal box.

⚠ DANGER

ELECTRIC SHOCK! Make sure electrical wires are not pinched or damaged when installing terminal box cover.

6. Connect waste line to disposer.
7. Connect cold water supply to disposer body water inlet (if previously installed).
8. Turn on electrical and water supply.
9. Test the disposer to ensure the cutting elements revolve and the water flows automatically. Make sure the disposer is securely mounted and does not leak from any of the connections.

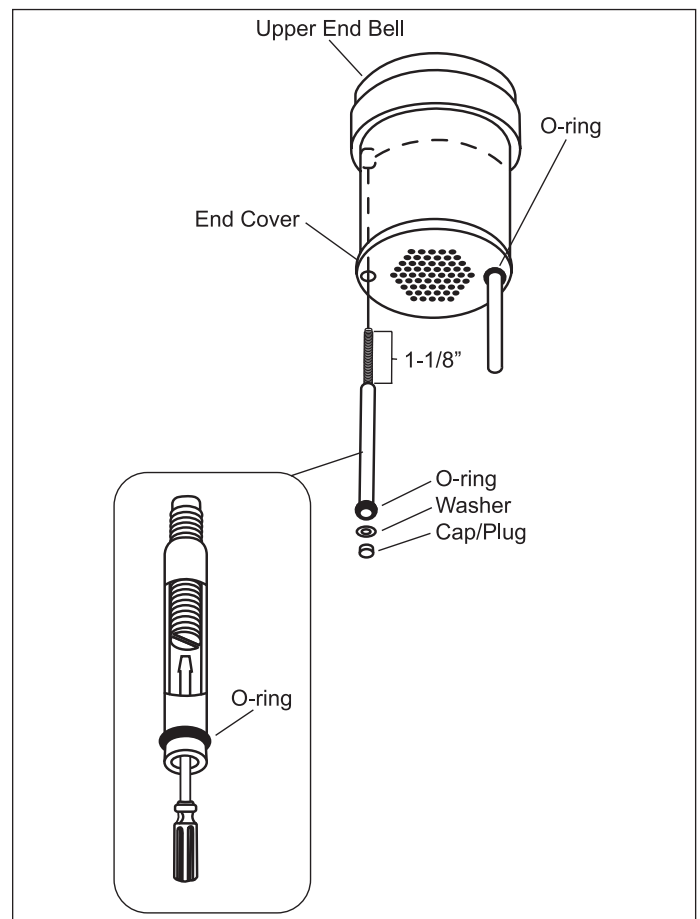

Figure 6. Disposer Leg

Common Repair Areas

GRIND CHAMBER

- Stationary Shredder Gasket
- Stationary Shredder
- Rotating Shredder

UPPER END BELL (UEB)

- Seals & Bearings

ELECTRICAL

- Overload
- Capacitor
- Stator
- Rotor & Centrifugal Switch
- Lower End Frame (LEF)



Figure 7. Common Repair Areas

Terminal Box & Trim Band

⚠ DANGER

ELECTRIC SHOCK! Turn off water and electrical supply. Discharge capacitor with 1000 ohm jumper wire (1 Phase only). Do not use a screwdriver to discharge or capacitor may be damaged.



NOTE: Terminal box and trim band are removed for all repairs except overload and start capacitor.

Removal

1. Remove screw and terminal box (Figure 8).
2. Remove two screws securing trim band (Figure 9).
3. Spread the trim seam. While pivoting trim band upward and forward, slip band over terminal box bracket and remove band from disposer.

Installation

⚠ DANGER

ELECTRIC SHOCK! Make sure electrical wires are not pinched or damaged when installing terminal box cover

1. Insert trim band onto unit. Secure with two screws and tighten.
2. Install terminal box with overload protector positioned through rubber grommet. Take care not to pinch lead wires in terminal box.
3. Secure with screw.



Figure 8. Terminal Box



Figure 9. Trim Band

GRINDING CHAMBER

Replacing Water Inlet

NOTE: It is not necessary to remove the disposer to repair water inlet.

Water Inlet Kit part number is [13956](#).

1. Using a wrench, remove water inlet from upper body (Figure 10).
2. Remove any burrs on water inlet hole.
3. Wrap Teflon tape around new water inlet fitting and insert fitting through water inlet hole from inside of upper body.
4. Place O-ring in groove in water inlet nut. A small amount of grease may be used to hold O-ring in place during installation.
5. From outside of body, attach water inlet nut to water inlet fitting. Tighten nut with wrench.

NOTE: Water inlet fitting and nut are joined with a left-hand thread.

Replacing Shredder Gasket

1. Remove disposer. See “Removing Disposer” on page 7.
2. Remove screws securing tailpipe and gasket from upper end bell assembly (Figure 10).
3. Remove terminal box and trim band (Figure 10).
4. Remove screws securing body and cover assembly to upper end bell assembly (Figure 10).
5. Lift cover and upper body assembly off upper end bell assembly
6. Separate the upper body assembly from the cover.
7. Remove old gasket. Install new gasket to bottom edge of upper body (Figure 11).
8. Place cover over upper body.
9. Place cover and upper body assembly onto upper end bell assembly. There are two tabs on the inside of the cover. These tabs fit into the two side grooves on the upper end bell with the waste outlet aligned with the waste outlet cutout.
10. Secure in place with screws.
11. Install trim band and terminal box. See “Terminal Box & Trim Band” on page 9.
12. Re-install tailpipe gasket and tailpipe using screws (Figure 10).
13. Install disposer. See “Installing Disposer” on page 7.

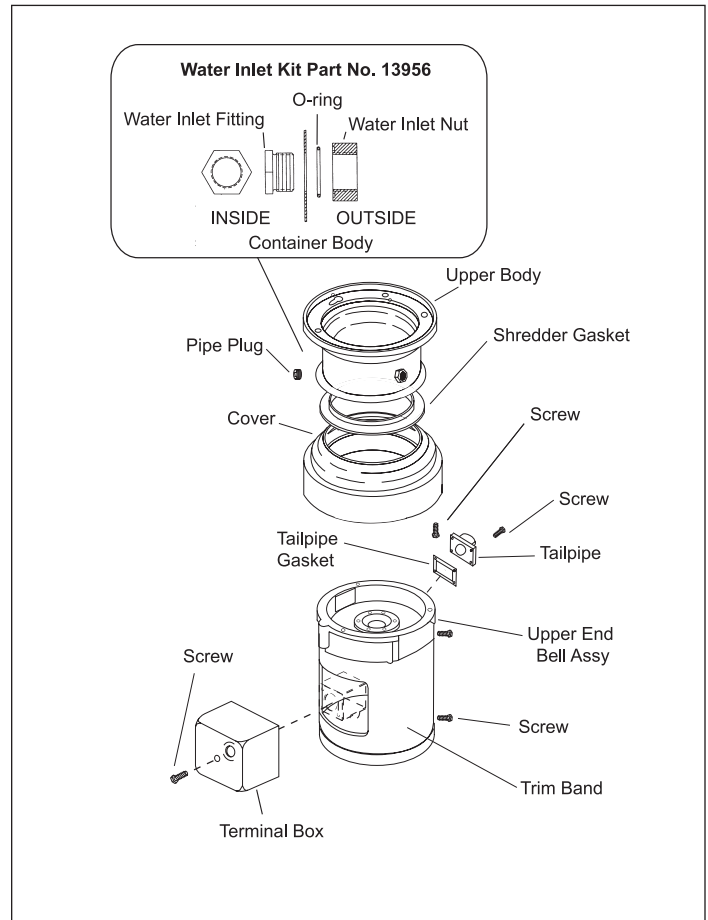

Figure 10. Cover and Upper Body Assembly



Figure 11. Replacing Shredder Gasket

Replacing Stationary Shredder

Removal

1. Remove disposer. See “Removing Disposer” on page 7.
2. Remove cover and upper body assembly. Perform steps 2 – 5 under “Replacing Shredder Gasket” on page 10.
3. Lubricate the full outside diameter of the shredder ring with penetrating oil.
4. Place a 1”D x 1-1/4”L long piece of pipe or similar sized hex socket over rotating shredder nut (Figure 12).
5. Using a 5/16” thick flat bar, rest bar on top of pipe or socket with flat end under shredder teeth. Strike jam release bar with a soft non-metallic mallet (rawhide, nylon, leather, wood) to break the seal and remove stationary shredder.

CAUTION Do not strike stationary shredder or shredder could be damaged.

Installation

1. Clean old silicone and dirt from upper end bell.
2. Apply water resistant silicone sealant around bottom of stationary shredder.
3. Place stationary shredder on upper end bell, aligning one stationary shredder groove with upper end bell weep hole (Figure 13). Strike stationary shredder firmly on alternate sides with soft mallet until securely seated.

CAUTION Do not use metal hammer or die cast stationary shredder will break.

4. Turn rotating shredder by hand and make sure it rotates freely.
5. Install cover and upper body. Perform steps 8–13 under “Replacing Shredder Gasket” on page 10.



Figure 12. Removing Stationary Shredder

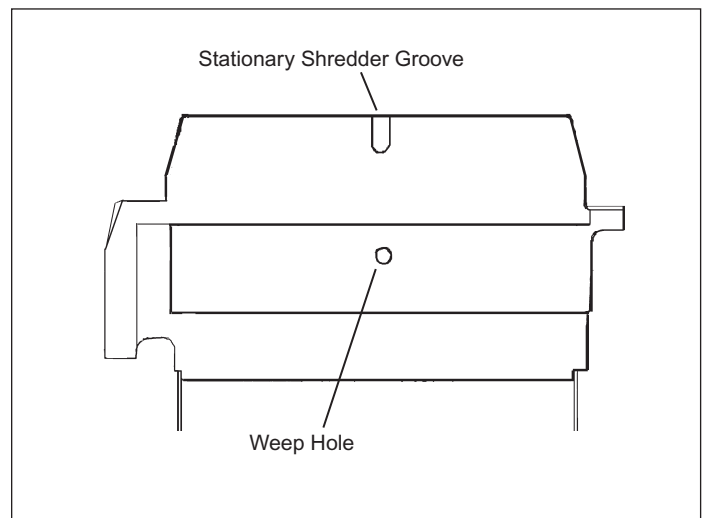

Figure 13. Aligning Stationary Shredder

Replacing Rotating Shredder

Removal

1. Remove disposer. See “Removing Disposer” on page 7.
2. Remove stationary shredder. See “Replacing Stationary Shredder” on page 11.
3. Lubricate shredder nut and shaft threads with penetrating oil.
4. Secure rotating shredder with a vice-grips or channel lock pliers and remove rotating shredder nut using a socket or box wrench (Figure 14).
5. Place gear puller onto rotating shredder as shown (Figure 15).

CAUTION Do not attempt to use gear puller to remove the shredder without following step 5. Tighten the puller until it creates resistance on the rotating puller, then proceed to step 6.

6. Tighten puller until snug. Tap around shredder hub 6-8 times. Tighten puller 1/4 turn (maximum) and repeat. Shredder will release from shaft after a number of repetitions.

Installation

1. Place rotating shredder on shaft, aligning shredder keyways with shaft keys. Tap with a soft mallet until seated.
2. Install fiber washer, steel washer and self-locking hex mounting nut (Figure 16).
3. Hold rotating shredder with vise-grips or channel lock and tighten mounting nut with socket or box wrench (Figure 14).
4. Install stationary shredder. Perform Installation procedure under See “Replacing Stationary Shredder” on page 11.
5. Install disposer. See “Installing Disposer” on page 7.



Figure 14. Rotating Shredder Nut

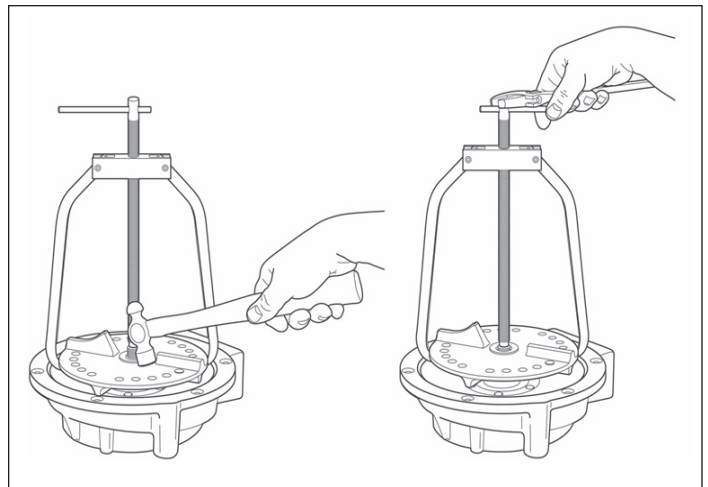

Figure 15. Removing Rotating Shredder

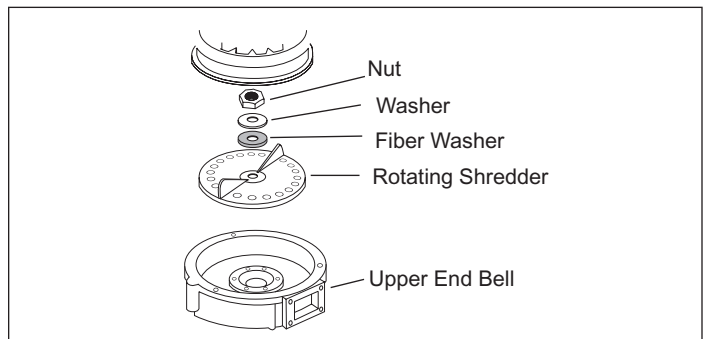

Figure 16. Installing Rotating Shredder

UPPER END BELL (UEB)

Repairing Upper End Bell Assembly

1. Remove disposer. See "Removing Disposer" on page 7.
2. Turn unit right side up and remove body and upper cover assembly, stationary shredder and rotating shredder. See "Replacing Rotating Shredder" on page 12.
3. Turn unit upside down and remove lower cover, fan and stator. See "Removing the Stator" on page 20.
4. Remove two woodruff keys (one each side) from rotor shaft and remove shield and spacer sleeve (Figure 17).
5. Remove screws securing seal assembly to upper end bell. Work flat head screwdriver under seal lip and pry up to remove seal assembly (Figure 18).
6. Remove third woodruff key from rotor shaft. Slide O-ring and slinger off rotor shaft (Figure 19).



Figure 17. Spacer Sleeve



Figure 18. Seal



Figure 19. O-ring and Slinger

7. Carefully remove rotor shaft from upper end bell (Figure 22).

NOTE: Do not remove lower bearing or centrifugal switch (1 Phase only) from rotor. If centrifugal switch is damaged, rotor shaft assembly must be replaced

If bearing is damaged, press bearing off rotor shaft, supporting rotor shaft by the bearing. Press new bearing onto shaft until fully seated on shaft groove.

8. Remove water and oil seal, bearing set and spacer from motor side of UEB (Figure 20).

NOTE: On SS-300, SS-500, SS-750 and SS-1000 units, remove steel thrust washer.

CAUTION Do not attempt to remove large snap ring from center of upper end bell. Snap ring cannot be removed without damaging upper end bell.

9. Using wood block and mallet, knock both bearing races out from UEB.

10. Clean upper end bell of all grease, dirt and sealant. Clean outside diameter of bearing cup and wipe dry with clean rag (Figure 21).

11. Coat inner wall of bearing cavity with #242 Loctite and fully seat new race (bevel side outwards). Turn end bell over and repeat for other side.

12. Lubricate new bearing pack with Texaco RV1939 or equivalent and install bearing pack into cavity on motor side of UEB.

13. Place new water & oil seal squarely into end bell recess (motor side). Using a wood block or soft mallet, tap seal into end bell recess until it is flush with casting.

NOTE: On SS-300 and SS-500 (serial # 70,000 and above) and SS-750 and SS-1000 units, install steel thrust washer.

14. Carefully insert rotor assembly into UEB from motor side.
15. Install stator, lower end frame, fan and bottom cover. See "Stator" on page 20.

16. Install slinger and O-ring (Figure 19). O-ring should fit snug against slinger.

17. Install lower woodruff key into shaft keyway.

18. Install spacer sleeve with channel fitting over O-ring, aligning sleeve notch with woodruff key (Figure 22).

19. Coat machined face and groove (with 6 holes) of upper end bell with water proof silicone sealant (Figure 21).

20. Install seal assembly and secure with screws (Figure 18).

21. Install shield and two woodruff keys.



Figure 20. Water and Oil Seal



Figure 21. Cleaning Upper End Bell

22. Install stationary and rotating shredder. See Installation under "Replacing Stationary Shredder" on page 11 and "Replacing Rotating Shredder" on page 12.
23. Place cover and upper body assembly onto upper end bell assembly. There are two tabs on the inside of the cover. These tabs fit into the two side grooves on the upper end bell with the waste outlet aligned with the waste outlet cutout.
24. Install trim band and terminal box. See "Terminal Box & Trim Band" on page 9.
25. Re-install tailpipe gasket and tailpipe using screws ("Cover and Upper Body Assembly" on page 10).
26. Install disposer. See "Installing Disposer" on page 7.

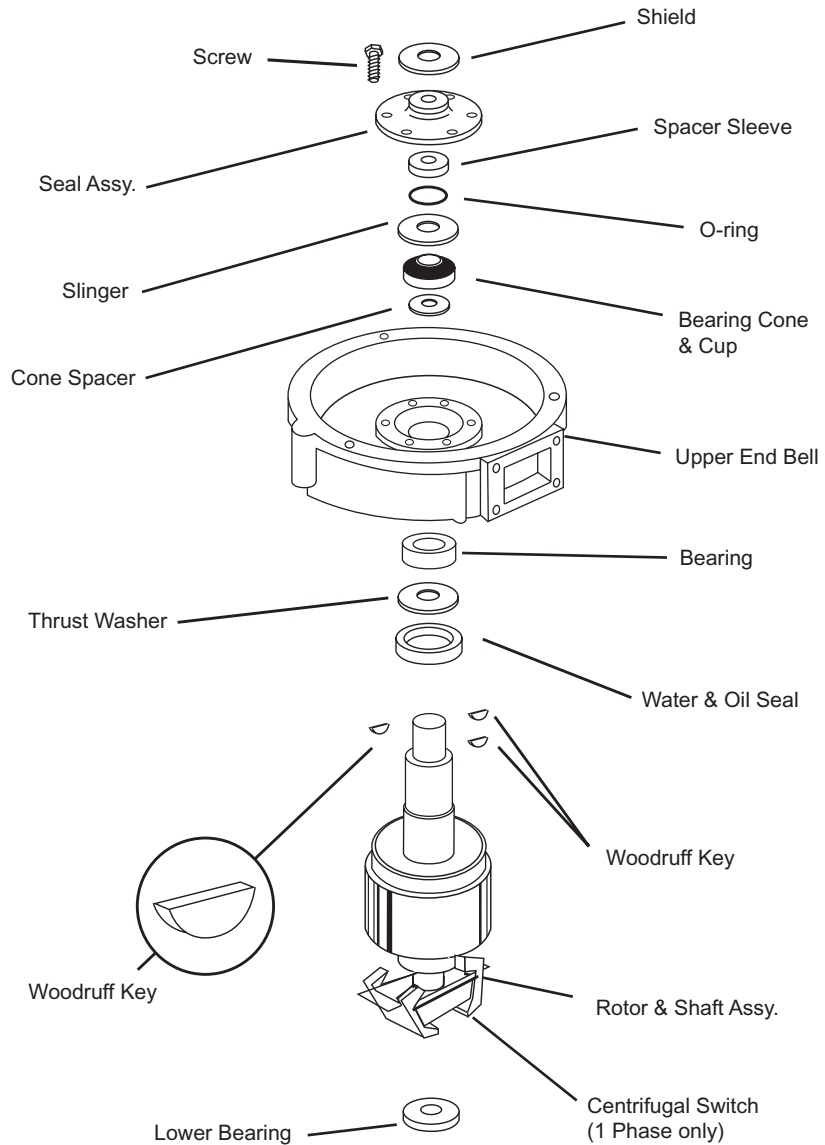

Figure 22. Upper End Bell and Rotor Assembly

ELECTRICAL REPAIRS

Overload Protector

Testing Overload Protector

⚠ DANGER **ELECTRIC SHOCK!** Turn off water and electrical supply. Discharge capacitor with 1000 ohm jumper wire (1 Phase only). Do not use a screwdriver to discharge or capacitor may be damaged.



⚠ CAUTION Do not use a screwdriver to discharge or capacitor may be damaged.

1. Remove screw and terminal box (Figure 23).
2. Remove two screws securing overload protector to bracket and pull out from unit. Disconnect overload wires from stator.
3. Push red button in and check continuity between all terminals and center post using an ohmmeter.
 - 3 terminals – 1 Ø
 - 6 terminals – 3 Ø
4. There should be continuity between all terminals and center post. Replace overload protector if circuit is open on any terminal and center post combination.
5. Re-install terminal box as described previously on this page.

Replacing Overload Protector

1. Remove screw and terminal box (Figure 23).
2. Disconnect wires.
3. Remove two screws securing overload protector to bracket, disconnect wires and remove protector.
4. Connect new switch wires and tuck wires into bracket and secure new protector to bracket using two screws.
5. Re-install terminal box and screw.

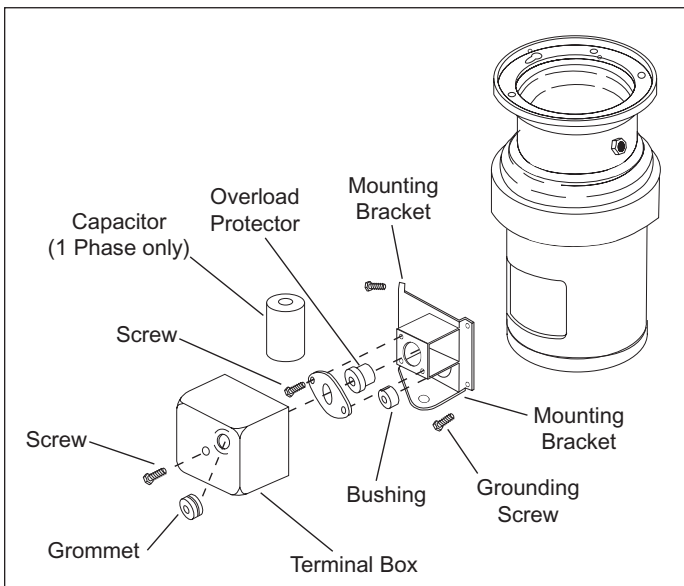

Figure 23. Terminal Box and Components

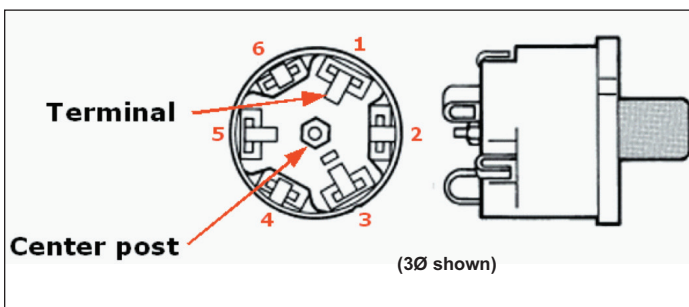

Figure 24. Testing Overload Protector

Capacitor

(1 Phase units only)

Testing Capacitor

⚠ DANGER

ELECTRIC SHOCK! A charged capacitor will hold an electric charge until it is discharged or shorted out. **DO NOT** touch capacitor terminals or electric shock may occur.

⚠ DANGER

ELECTRIC SHOCK! Turn off water and electrical supply. Discharge capacitor with 1000 ohm jumper wire (1 Phase only). Do not use a screwdriver to discharge or capacitor may be damaged.



⚠ CAUTION

Do not use a screwdriver to discharge or capacitor may be damaged.

1. Remove screw and terminal box (Figure 23).
2. Insert a flat blade screwdriver between capacitor clip and capacitor and gently pry capacitor from bracket.
3. Mark and remove lead wires from capacitor terminals. If flag connectors are not present, cut lead wires approximately 1" from terminal on capacitor.
4. Set ohmmeter to highest scale. Connect ohmmeter probes to capacitor terminals (Figure 25).
 - If meter does not move, capacitor is open. Replace it.
 - If meter needle jumps to zero and stays there, capacitor is shorted. Replace it.
 - If meter needle jumps to zero and slowly rises toward infinity, capacitor is working.

Installing Capacitor

1. Reconnect wires to capacitor (flag connectors if present - otherwise solder into place).
2. Snap capacitor into place on bracket.
3. Install screw and terminal box (Figure 23).



Figure 25. Testing Capacitor

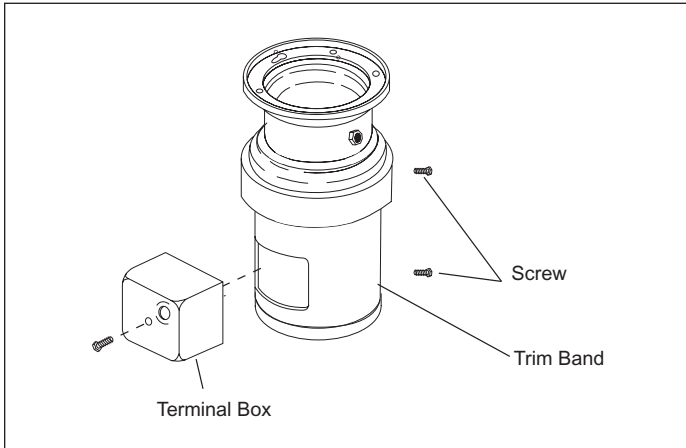

Figure 26. Terminal Box and Trim Band

Bottom Cover and Fan Removal

1. Remove disposer. See “Removing Disposer” on page 7.
2. Remove terminal box and trim band (Figure 26).
3. Place disposer upside down on a flat surface.
4. Remove the three thru bolts, bottom cover and three spacers (Figure 27).
5. Remove snap ring securing fan, then remove fan (Figure 28).

Installation

1. Install fan to shaft with tab on fan engaged in shaft keyway.
2. Install bottom cover with three spacers and secure with three thru-bolts. Secure thru bolts to upper end bell.

NOTE: When positioning bottom cover, make sure two leg holes line up with leg mounting holes on upper end bell assembly.

3. Reinstall trim band and terminal box (Figure 26).
4. Re-install disposer. See “Installing Disposer” on page 7.



Figure 27. Bottom Cover and Fan



Figure 28. Fan

Lower End Frame (LEF)

Removal

1. Remove disposer. See "Removing Disposer" on page 7.
2. Remove bottom cover and fan. See "Bottom Cover and Fan" on page 18.
3. Place a reference mark over the seam between the lower end frame and stator (Figure 30).
4. Remove lower end frame by lightly tapping thru bolt guides with rawhide or nylon mallet (Figure 30).

Replacing Start Switch

(1 Phase Models)

1. Remove lower end frame as described above.
1. Mark and disconnect wires from start switch (Figure 29).
2. Secure new start switch to lower end frame with two screws.
3. Connect wires to switch.

Installation

1. Make sure pre-load spring is seated fully into lower end frame.
2. Align the reference mark on the lower end frame and stator. Gently tap lower end frame in place on stator (Figure 30).
3. Reinstall fan and bottom cover. See "Bottom Cover and Fan" on page 18.
4. Reinstall disposer. See "Installing Disposer" on page 7.

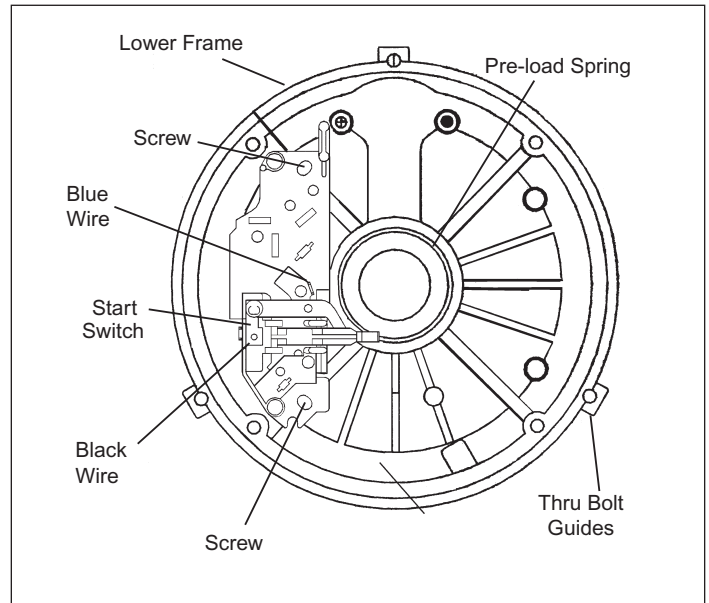

Figure 29. Start Switch - 1 Phase Only



Figure 30. Marking and Removing Lower End Framer

Stator

Removing the Stator

1. Remove disposer. See “Removing Disposer” on page 7.
2. Remove terminal box, trim band and lower end frame. See “Lower End Frame (LEF)” on page 19.
3. Mark and disconnect wires from start switch (1 phase only, see Figure 29).
4. Disconnect stator wires from overload protector.
5. On 1 phase models, remove capacitor wires by either removing flag connectors or heating solder joints on capacitor
6. Remove screws and mounting bracket from stator assembly (Figure 31).
7. Place scribe marks on upper end bell assembly to align with terminal mounting bracket holes on stator (Figure 32).
8. Lay assembly on its side. Gently tap on rotor shaft assembly with a soft non-metallic (rubber or nylon) mallet to separate stator from upper end bell assembly.

WARNING Stator is not secured to upper end bell and may drop out.

Testing Stator Windings

Using an ohmmeter, test the start and run windings for continuity. If testing indicates open, shorted, or grounded across any combination, replace the stator.

Testing 1 Phase Stator

1. **Disconnect and isolate** all stator leads.
2. Capacitor, overload protector and start switch should be tested individually before testing stator. Disconnect all three and isolate wires from stator before conducting stator test.
3. Using an ohmmeter, check continuity across leads (Figure 33):
 - #2 and #9 start windings,
 - #1 and #4 run windings,
 - #3 and #8 run windings.
4. Check all leads individually to ground. If any continuity is found, replace stator.

Testing 3 Phase Stator

1. Disconnect and isolate all stator leads.
2. Using an ohmmeter, check continuity across leads (Figure 34).
 - #1 and #4 #7 and #13
 - #2 and #5 #8 and #14
 - #3 and #6 #9 and #15
3. Check all leads individually to ground. If any continuity is found, replace stator.

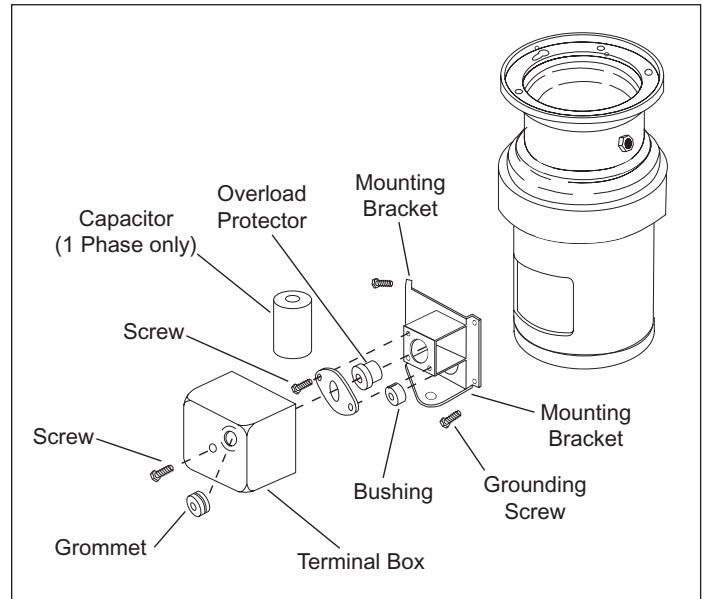

Figure 31. Terminal Box and Components

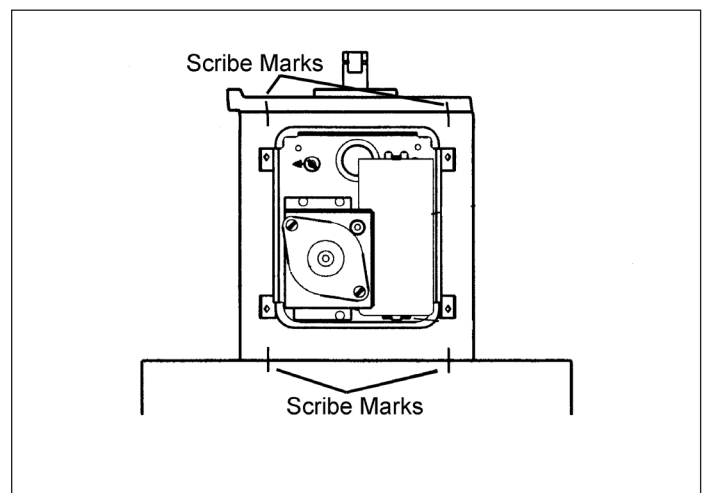

Figure 32. Scribe Marks on Lower End Frame

Installing the Stator

1. Install mounting bracket to new stator (Figure 31).
2. Reconnect stator wires to overload protector and capacitor (if equipped). Reconnect wires to capacitor.
3. Install lower end frame. On 1 phase models, install start switch. Reconnect stator wires to start switch (Figure 29). See “Lower End Frame (LEF)” on page 19.
4. Align mounting bracket holes on new stator with scribe marks on upper end bell assembly (Figure 32). Gently tap stator into place on upper end bell assembly.

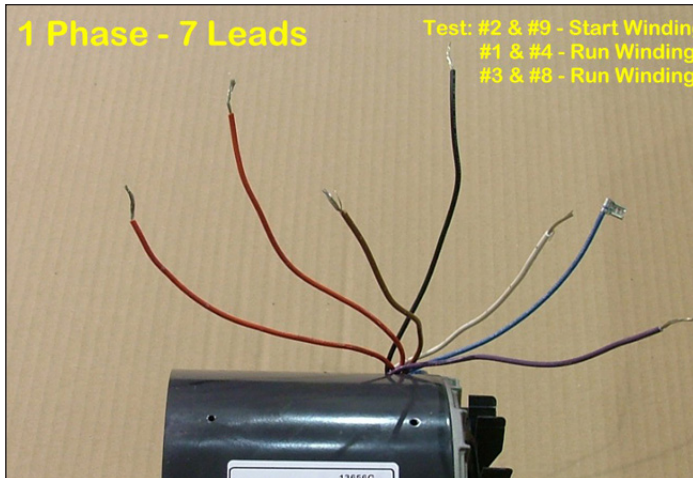

Figure 33. Testing 1 Phase Stator

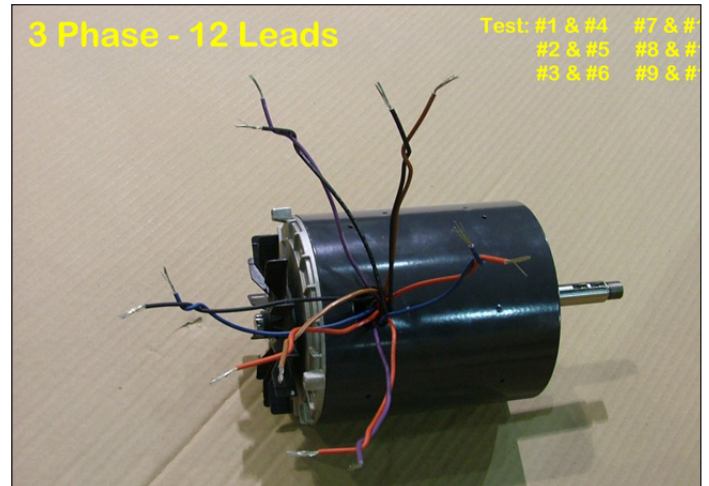

Figure 34. Testing 3 Phase Stator

5. Install bottom cover and fan. See “Bottom Cover and Fan” on page 18.
6. Install trim band and terminal box. See “Terminal Box & Trim Band” on page 9.
7. Install disposer. See “Installing Disposer” on page 7.

Motor Leads connections

Commercial disposers produced since April, 1985 are manufactured with tri-voltage motors.

115/208/230V	Single Phase	7 leads
208/230/460V	Three Phase	12 leads

NOTE: SS-50 through SS-200 – 1 and 3 phase commercial disposers produced prior to January 2009 (0901 date code) may not be color coded and may incorporate black wire leads with white lettering.

Commercial disposers produced before April, 1985 were manufactured with single- or dual-voltage motors. These models are not repairable and must be replaced if service is required. Contact InSinkErator to verify current replacement model.

115/230V	Single Phase	7 leads
208V	Single Phase	7 leads
230/460V	Three Phase	12 leads
208V	Three Phase	3 leads

NOTE: For information on servicing InSinkErator Control Centers, refer to the instructions included with the Control Center.

⚠ DANGER

Electrical Shock!

Turn off electrical supply to the disposer before attempting any service work. Use a voltmeter or circuit tester to ensure that power is off.

Installation must conform to local electrical codes.

WIRING DIAGRAMS

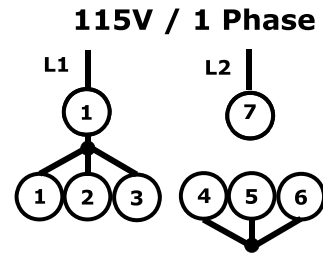
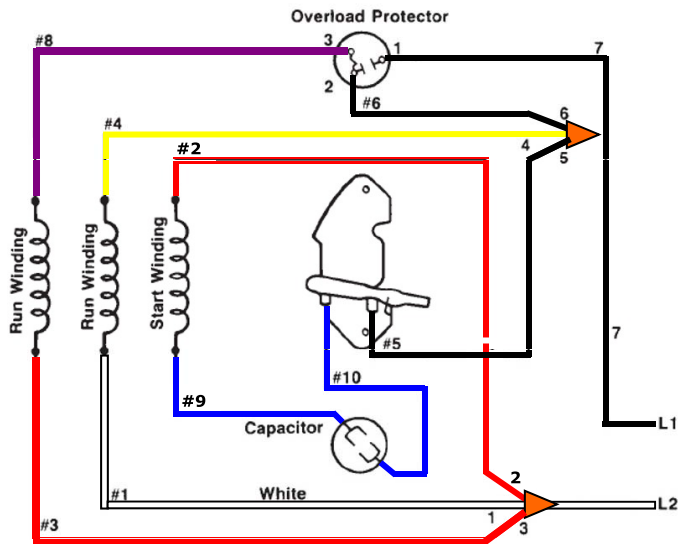

Flag connectors on #9
And #10 at capacitor

Note: #4 wire may be
yellow or brown.

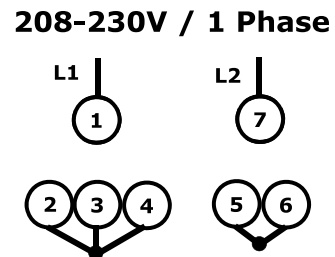
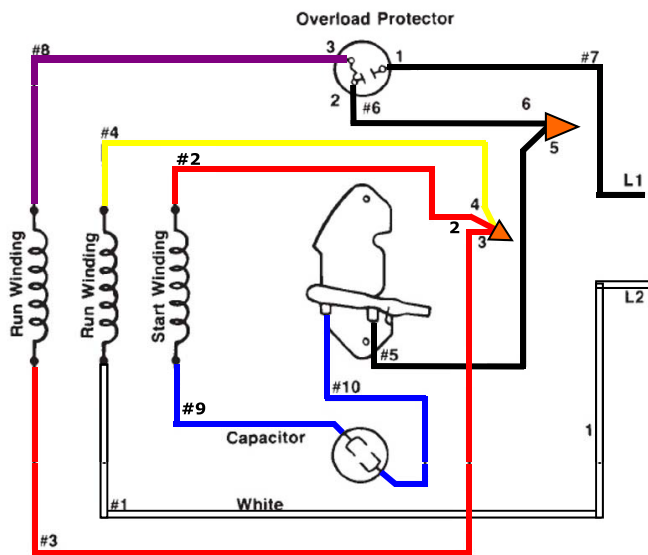

Flag connectors on #9
And #10 at capacitor

Note: #4 wire may be
yellow or brown.

Figure 35. 1 Phase

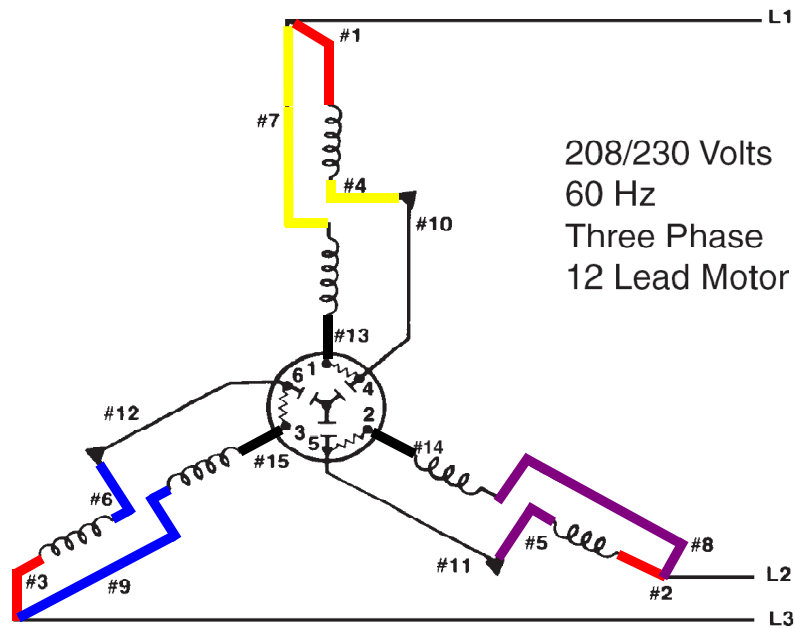

Note: SS300 - SS1000 supplied with black and white leads.

Note: #4 or #7 wire may be yellow or brown.

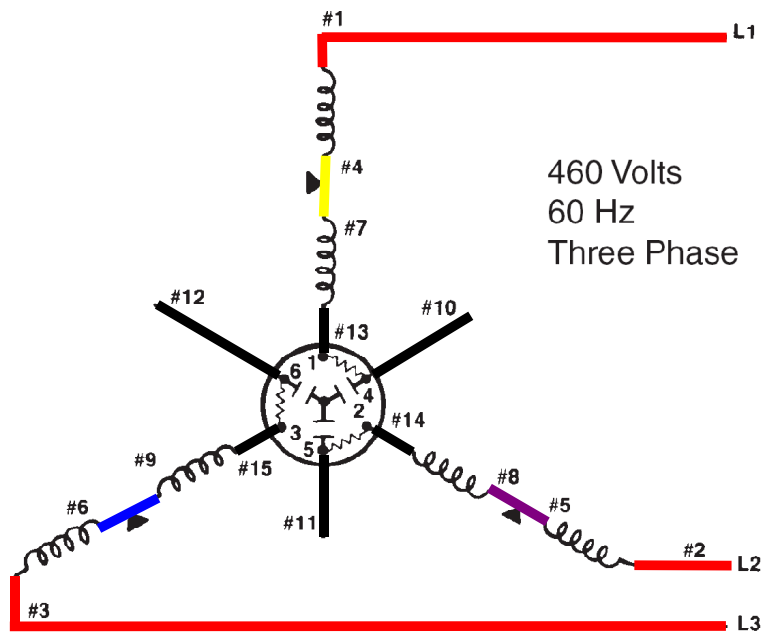

Note: SS300 - SS1000 supplied with black and white leads.

Note: #4 wire may be yellow or brown.

Figure 36. 3 Phase

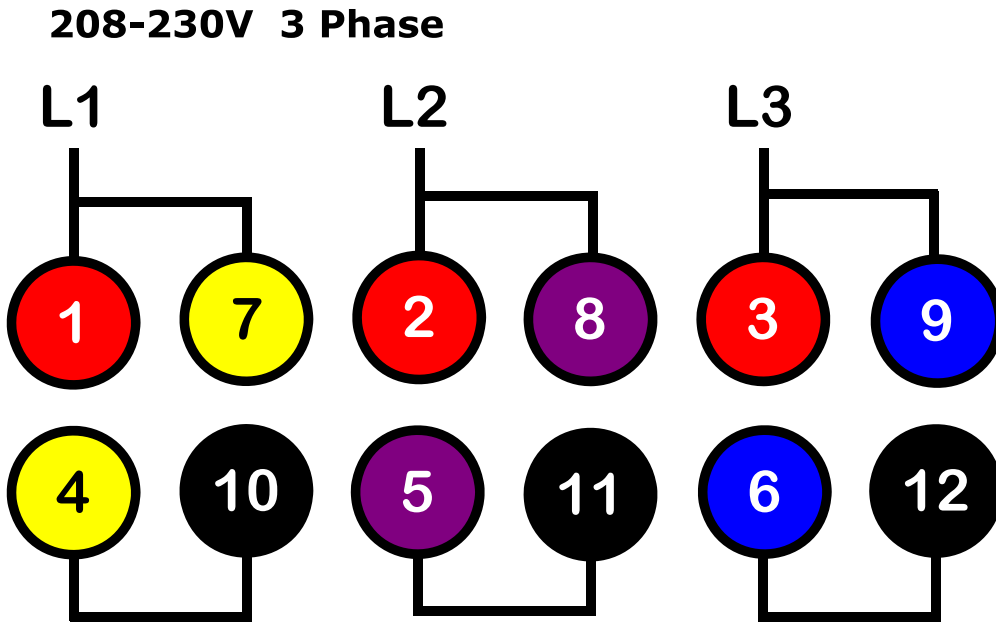

Note: #4 and #7 may be either yellow or brown.

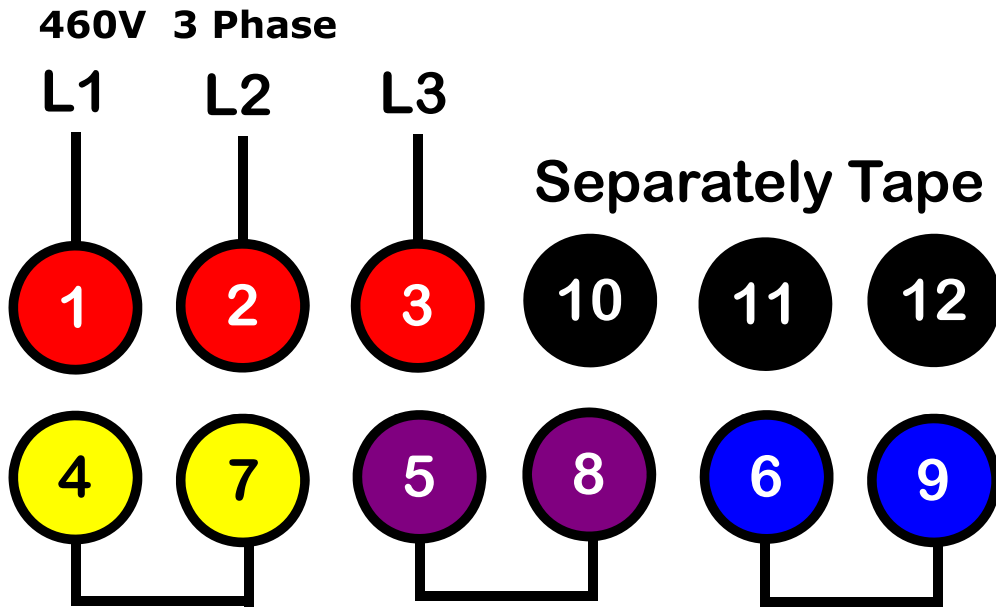

Note: #4 and #7 may be either yellow or brown.

Figure 37. 3 Phase Motor Connections

TROUBLESHOOTING



Disconnect power before troubleshooting or servicing the disposer.



Troubleshooting problems other than those listed in this section should be performed by qualified service personnel. Any troubleshooting performed by untrained personnel could result in electrical shock or damage to the disposer.

If the problem is electrical:

- To determine if the problem is in the switch or the disposer, bypass all electrical starting and/or electrical controls and run the disposer direct.
- Make sure the disposer electrical specifications match the electric power supply.
- Make sure the motor lead connections are correct for the corresponding power supply and starting controls.
- Determine if there are electrical problems with other kitchen appliances. This may indicate a problem in the building's electrical circuitry.

Problem	Cause	Solution
Disposer will not start but water runs.	Overload protector tripped.	Allow 5 minute cooling period and reset overload protector.
	Overload protector burned out; open circuits.	Test and replace overload protector. See "Overload Protector" on page 16.
	Stator burned out; open windings	Test stator. See "Stator" on page 20. Inspect for pinched (grounded/shorted) stator lead wires.
	Jammed rotating shredder.	Turn the control to the OFF position and complete the following steps: <ol style="list-style-type: none"> 1. Insert the dejamming bar (slot down) through the sink opening. Place the slot over one end of the raised bars found on the top of the rotating shredder. 2. Using an adjustable wrench or a pipe wrench for leverage, twist the dejamming bar back and forth to free the jam. The rotating shredder should move freely when the jam is released. 3. Remove all foreign matter that caused the stoppage. 4. Allow the disposer to cool for 3-5 minutes after it stops running. Press the red reset button to reset the overload protector. Never strike the reset button with an object. 5. If the disposer remains inoperative after following these steps, contact the nearest InSinkErator Factory Authorized Service Center. Call 1-800-558-5700 to obtain the telephone number of the nearest center.
	Water in stator area.	Inspect and fix water leak. See Water in Stator in this section.
Disposer will not start and water does not run.	No power to disposer.	Replace switch or repair control center. Check for blown fuses or tripped circuit breaker.
	Disposer control switch not connected or faulty.	Connect or repair/replace control switch.

Problem	Cause	Solution
Motor hums but does not run; water runs.	Jammed rotating shredder. Stator/lower end frame/upper end bell misaligned (thru bolts loose, bent, or broken).	See previous “Jammed rotating shredder” solution. Remove and realign sections. Ensure thru bolts are not bent or broken. Replace bolts if necessary.
	Rotor shaft binding against stator core.	Check inside diameter of stator core and outside diameter of rotor shaft core for score marks and replace stator or rotor shaft if necessary. See “Stator” on page 20 or “Lower End Frame (LEF)” on page 19. Check for worn bearings and replace if necessary. See “Repairing Upper End Bell Assembly” on page 13.
	Start switch inoperative (1 Phase only).	Replace start switch. See “Replacing Start Switch (1 Phase Models)” on page 19.
	Stator windings open.	Test stator windings and replace stator if open. See “Stator” on page 20. Check for water leaks and repair as necessary.
	Weak capacitor charge (1 Phase only).	Test capacitor and replace if necessary. See “Testing Capacitor” on page 17.
	Improper voltage to disposer.	Test power supply for proper voltage and phase, and correct if necessary.
	Incorrect wiring at motor and/or starting switch or solenoid valve.	Refer to the appropriate wiring diagram.
Disposer runs briefly, then trips overload protector.	Centrifugal actuator stuck open or closed, or actuator spring is loose (1 Phase only).	Inspect centrifugal actuator. Replace rotor assembly.
	Start switch contacts arced (1 Phase only).	Replace start switch. See “Replacing Start Switch (1 Phase Models)” on page 19.
	Stator windings shorted.	Test stator windings and replace stator if open. See “Stator” on page 20. Check for water leaks and repair as necessary.
	Water in stator.	Inspect and fix water leak. See Water in Stator in this section.
	Disposer jammed.	See previous “Jammed Rotating Shredder” solution.
	Improper power supply.	Electrical supply must be connected by an electrician.
	Improper wiring connection.	See applicable wiring diagram and reconnect wiring.
	Electrical supply line overloaded.	Connect disposer to another circuit. Disposer should only be on appliance circuit.
Faulty or improperly connected overload protector.	See applicable wiring diagram for correct connections and/or replace overload if necessary. See “Overload Protector” on page 16.	
Disposer runs slow and/or stops when food waste is inserted.	Low voltage power supply connected to high voltage stator connections.	See applicable wiring diagram and reconnect motor leads for corresponding voltage.

Problem	Cause	Solution
Overload protector is tripped or fuse/circuit breaker blows immediately after starting disposer.	Direct short in stator windings.	Test stator windings and replace stator if open. See "Stator" on page 20.
	Incorrect wiring connections.	See applicable wiring diagram in installation manual.
	Start switch wired incorrectly.	See applicable wiring diagram and correct connections.
	Contact on start switch is welded (1 Phase only).	Replace contact or start switch. See "Replacing Start Switch (1 Phase Models)" on page 19.
	Incorrect voltage.	Check disposer electrical specifications, power supply, and stator lead connections.
	Improper fuse or circuit breaker.	Check fuse or circuit breaker and have an electrician correct if necessary.
Disposer motor runs but little or no water runs.	Faulty overload protector.	Test and replace overload protector if necessary. See "Overload Protector" on page 16.
	Water supply is shut off.	Open water supply valve and adjust for the recommended gallons per minute (GPM). See "Cold Water Flow & Drain Line Diameter" on page 3.
	Faulty water solenoid.	Replace water solenoid.
	Low water pressure.	Consult plumber regarding solution.
	Improperly installed or inoperative time delay relay.	See applicable wiring diagram for proper connections. Replace time delay relay if faulty.
Water in stator.	Bearing seals worn.	Replace with bearing and seal kit. See "Repairing Upper End Bell Assembly" on page 13.
	Upper end bell cracked or eroded.	Replace upper end bell. See "Repairing Upper End Bell Assembly" on page 13.
	Water sprayed into motor during cleaning.	Instruct cleaning crew no to spray disposer with water.
Disposer squeals during operation.	Bearings are worn.	Replace with bearing and seal kit. See "Repairing Upper End Bell Assembly" on page 13.
	Rotor core loose on rotor shaft assembly.	Replace rotor shaft assembly. See "Repairing Upper End Bell Assembly" on page 13.
Disposer vibrates excessively.	Excessive water entering disposer.	Adjust water flow to recommended gallons per minute (GPM). See "Cold Water Flow & Drain Line Diameter" on page 3. If unit is installed with #5 mounting assembly, drain water from sink before operating disposer.
	Disposer overloaded with hard food waste or non-biodegradable material.	Clear disposer of waste and do not overload.
Water leaks at mounting or waste discharge.	Improper installation.	See Installation Guide and reinstall disposer.
	Loose mounting screws.	Tighten all mounting screws. Tighten locking ring if #5 mounting assembly is used.
	Pinched or broken mounting gasket.	Replace mounting gasket.

Problem	Cause	Solution
Water leaks from grind chamber area.	Stationary shredder gasket faulty.	Replace gasket. See "Replacing Shredder Gasket" on page 10.
	Water inlet connection loose in body.	Replace water inlet connection. See "Cold Water Flow & Drain Line Diameter" on page 3.
	Bottom cover loose or damaged.	Tighten or replace cover. See "Bottom Cover and Fan" on page 18.
	Stationary shredder damaged.	Replace it. See "Replacing Stationary Shredder" on page 11.
Water leaks from siphon breaker.	Loose plumbing connections.	Tighten plumbing connections.
	Improper installation.	See Installation Guide and reinstall disposer.
Water does not drain or drains slowly.	Drain line blocked.	Clean drain lines from dispose to main sewer. Vent lines may also required cleaning.
	Waste outlet centerline is below drain line centerline.	Adjust plumbing so drain line centerline is below waste outlet connections.
	Improper drain line slope.	Adjust the drain line slope to a minimum fall of 1/4" per foot.
	Grind elements worn or broken.	Replace rotating and/or stationary shredder. See "Replacing Stationary Shredder" on page 11 and "Replacing Rotating Shredder" on page 12.
Water splashes from disposer during operation.	Excessive water entering disposer and/or excessive water pressure.	Reinstall solenoid valve with arrow pointing downstream. Disassemble solenoid valve, clean and reinstall. Adjust water amount entering disposer. See "Cold Water Flow & Drain Line Diameter" on page 3. If water pressure can not be adjusted, install safety baffle, silver guard, and/or cover.
Water splashes from sink bowl.	Spray nozzle not installed properly.	Spray nozzle should be angled downward approximately 15° - 20°.
Water runs continuously after disposer is turned off.	Solenoid valve installed backward.	Arrow on solenoid must point downstream.
	Solenoid valve dirty.	Replace solenoid valve.
	Diaphragm bleeder hole out of position.	Replace solenoid valve.
	Water pressure too high.	Reduce water pressure.
	Normal operation with time delay relay.	Time delay relay can be set for five seconds to ten minute post flush.
Defective time delay relay.	Check time delay relay circuitry with volt meter and replace if necessary.	

Problem	Cause	Solution
Grinding elements worn excessively.	Disposer undersized for application.	Replace disposer with correct size. See “Serial Number Date Code” on page 2.
	Large amounts of highly abrasive material ground regularly.	Replace rotating shredder and/or stationary shredder. See “Replacing Stationary Shredder” on page 11 and “Replacing Rotating Shredder” on page 12. Do not grind abrasive material such as glass, crockery, ceramic, or clam shells.
	Non-biodegradable material ground.	Replace rotating shredder. See “Replacing Rotating Shredder” on page 12. Do not grind non-biodegradable material.
	Excessive water entering disposer.	Adjust water to recommended gallons per minute (GPM). See “Cold Water Flow & Drain Line Diameter” on page 3.
Disposer does not grind food waste.	Insufficient grind time.	Do not turn unit off until all food waste has been ground and flushed away. Allow water to run for 3 minutes after grinding is complete.
	Grinding elements worn.	Replace rotating shredder and/or stationary. See “Replacing Rotating Shredder” on page 12 and “Replacing Stationary Shredder” on page 11.
	Stationary shredder teeth plugged.	Disconnect power from disposer and clean stationary shredder grinder teeth.
	High drain time/too much water.	Restriction to waste line downstream of disposer. Clear clog.
Disposer runs only when bypassing electrical controls.	Inoperable or improperly installed controls.	Reference control wiring diagrams and rewire accordingly or replace if inoperable.

EXPLODED VIEWS & PARTS LISTS

SS-50 / SS-75 / SS-100 / SS-125

Small Capacity - 1 Phase UL & CSA

115/208-230V 60 Hz

UL Approved	SS-50-26	SS-75-27	SS-100-28	SS-125-25
CSA Approved	SS-50-28	SS-75-29	SS-100-30	SS-125-27

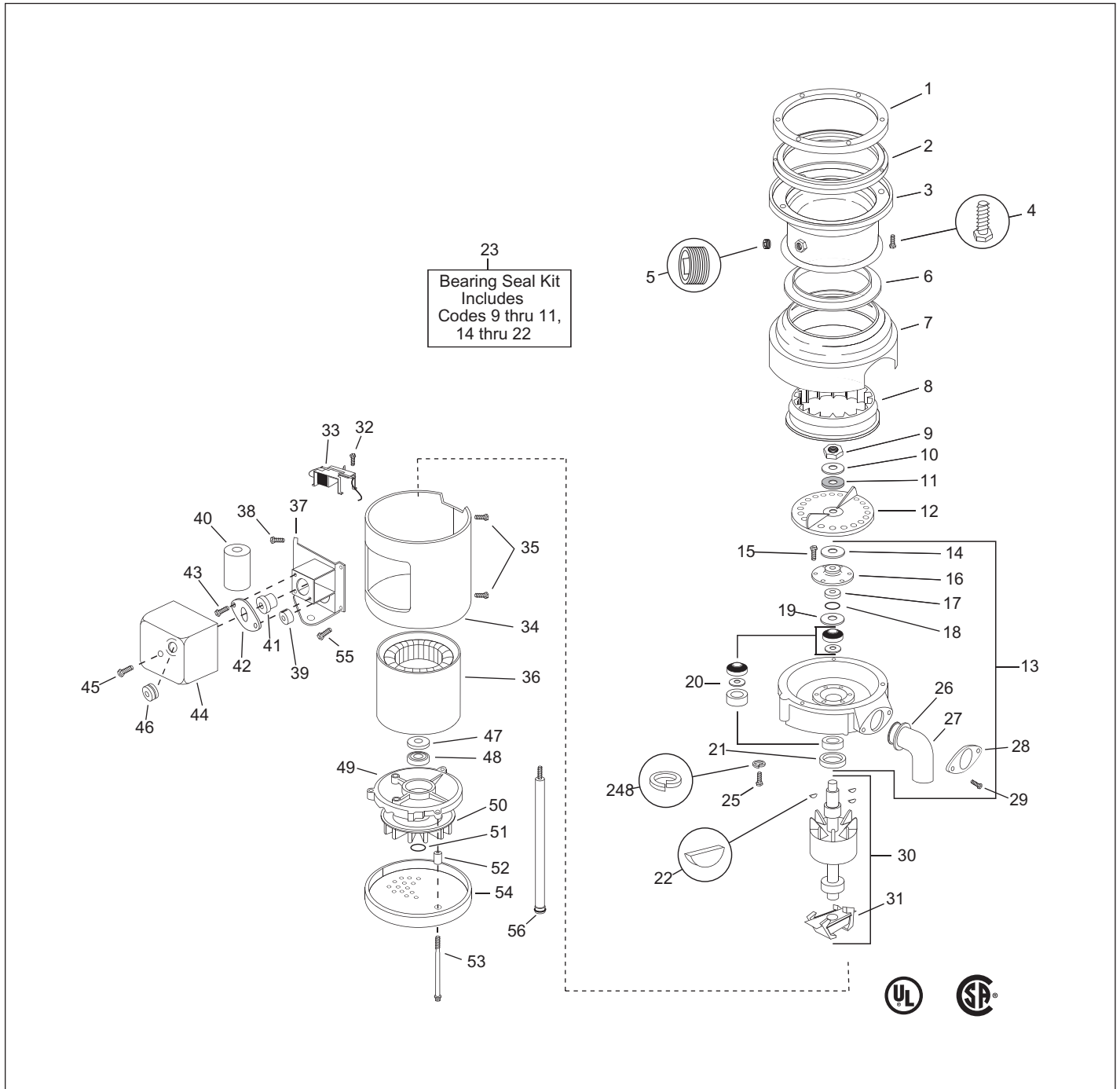

SS-50 / SS-75 / SS-100 / SS-125
Small Capacity - 1 Phase UL & CSA
115/208-230V 60 Hz

Item	Part No.	Description	Qty	Item	Part No.	Description	Qty
1	11004	Mounting Flange	1	28	1461	Flange, Tailpipe	1
2	11016	Gasket, Mounting	1	29	1468	Screw, 1/4-20 x 1/2"	2
3	11020A	Upper Body Assy.	1	30	See Chart A	Rotor & Shaft Assy. (includes item 31)	1
4	1491	Screw, 1/4-20 x 3/4"	6	31	Not Repairable	Centrifugal Actuator	1
5	11277	Pipe Plug	1	32	8221	Screw, 8-32 x 1/2"	2
6	11006	Gasket, Shredder	1	33	13707	Start Switch	1
7	12442ZZ	Body and Cover Assy.	1	34	12370ZZ	Trim Band	1
8	14664	Stationary Shredder	1	35	1836A	Screw, 8-32 x 1/2"	4
9	11260	Nut	1	36	See Chart A	Stator Assy.	1
10	12445	Washer	1	37	12433KZZ	Bracket Assy.	1
11	12142	Fiber Washer	1	38	11448	Screw, 8-18 x 1/4"	1
12	12944ZZ	Rotating Shredder	1	39	12384	Bushing	1
13	13722	Upper End Bell Assy (includes items 14-22)	1	40	11868	Capacitor	1
14	12936	Shield	1	41	See Chart A	Overload Protector	1
15	1269	Screw, 8-18 x 1/2"	6	42	12378	Clamp, Overload	1
16	12934A	Seal Assy.	1	43	8221	Screw, 8-32 x 1/2"	1
17	12935	Spacer Sleeve	1	44	13396ZZ	Terminal Box Assy. (includes 46)	1
18	12860	O-ring	1	45	12381	Screw, 8-32 x 1-1/4"	1
19	12319	Slinger	1	46	12383	Grommet, Overload	1
20	12610	Upper Bearing Assy.	1	47	13709	Lower Bearing	1
21	12326	Water & Oil Seal	1	48	13678	Pre-Load Spring	1
22	11322	Woodruff Key	3	49	13710	Lower End Frame	1
23	13080	Bearing Seal Kit (includes items 9-11 & 14-22)	1	50	13676ZZ	Fan	1
24	11444	Lock Washer	3	51	13677ZZ	Retaining Ring	1
25	3135	Screw, 1/4-20 x 1"	3	52	12490	Tube Spacer	3
26	1470	Gasket, Tailpipe	1	53	11940A	Thru Bolt	3
27	8219	Tailpipe	1	54	12396	Bottom Cover	1
				55	2466A	Screw, Ground	1
				56	11757B	Foot Tube Assy. (optional)	2

Chart A

Item	Description	Qty	SS-50	SS-75	SS-100	SS-125
30	Rotor & Shaft Assy. with Centrifugal Actuator	1	13674ZZ	13674AZZ	13274BZZ	13274CZZ
36	Stator Assy.	1	13713	13713A	13713B	13713C
41	Overload Protector	1	13422AK	13422J	13422E	13422C

SS-50 / SS-75 / SS-100 / SS-125

Small Capacity - 3 Phase UL & CSA

208-230/460V 60 Hz

UL Approved SS-50-27 SS-75-28 SS-100-29 SS-125-26

CSA Approved SS-50-29 SS-75-30 SS-100-31 SS-125-28

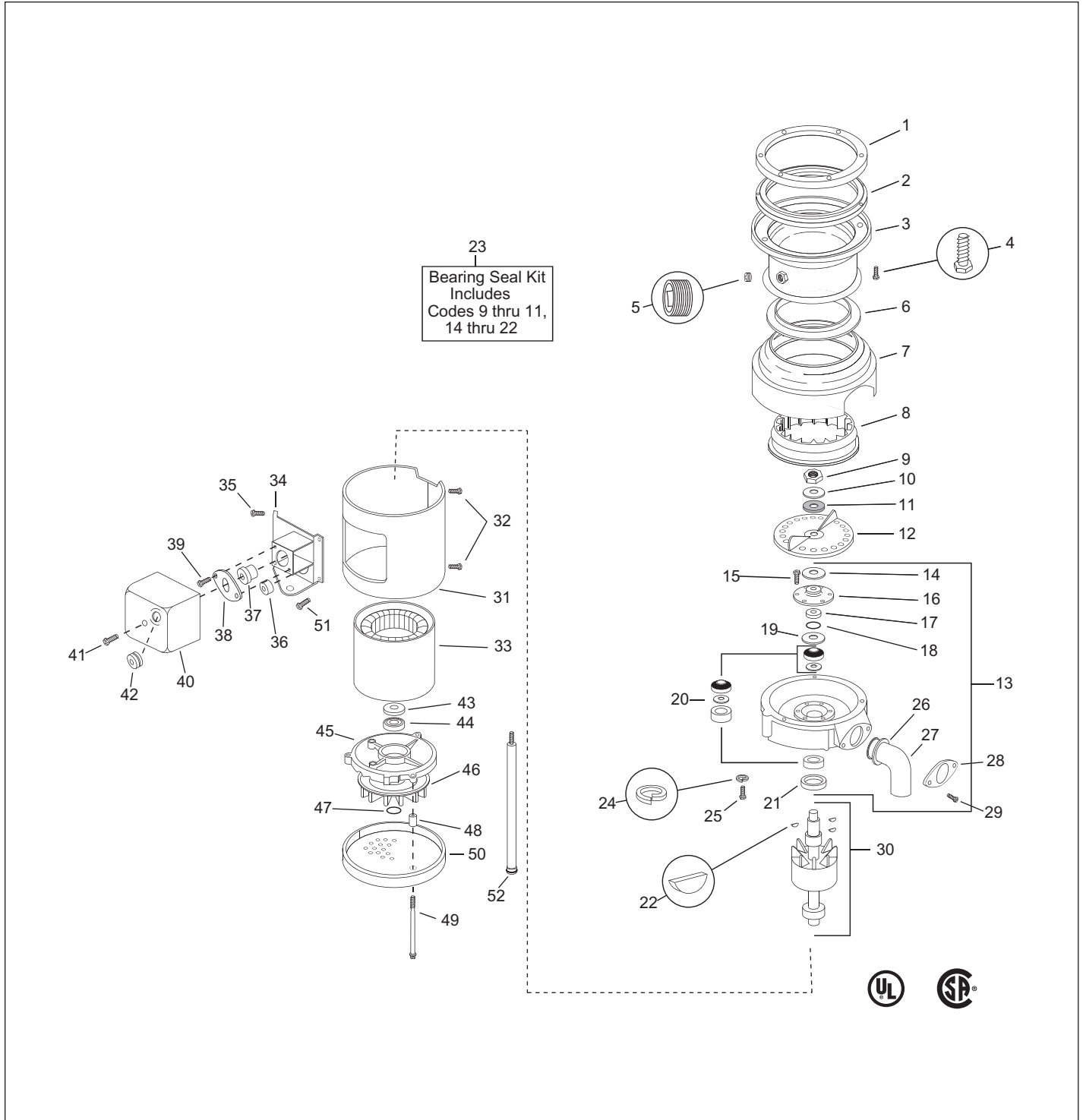

SS-50 / SS-75 / SS-100 / SS-125

Small Capacity - 3 Phase UL & CSA

208-230/460V 60 Hz

Item	Part No.	Description	Qty	Item	Part No.	Description	Qty
1	11004	Mounting Flange	1	26	1470	Gasket, Tailpipe	1
2	11016	Gasket, Mounting	1	27	8219	Tailpipe	1
3	11020A	Upper Body Assy.	1	28	1461	Flange, Tailpipe	1
4	1491	Screw, 1/4-20 x 3/4"	6	29	1468	Screw, 1/4-20 x 1/2"	2
5	11277	Pipe Plug	1	30	See Chart A	Rotor & Shaft Assy.	1
6	11006	Gasket, Shredder	1	31	12370ZZ	Trim Band	1
7	12442ZZ	Body and Cover Assy.	1	32	1836A	Screw, 8-32 x 1/2"	2
8	14664	Stationary Shredder	1	33	See Chart A	Stator Assy.	1
9	11260	Nut	1	34	12433EZZ	Mounting Bracket Assy.	1
10	12445	Washer	1	35	11448	Screw, 8-18 x 1/4"	4
11	12142	Fiber Washer	1	36	12384	Bushing	1
12	12944ZZ	Rotating Shredder	1	37	See Chart A	Overload Protector	1
13	13722	Upper End Bell Assy (includes items 14-22)	1	38	12378	Clamp, Overload	1
14	12936	Shield	1	39	8221	Screw, 8-32 x 1/2"	2
15	1269	Screw, 8-18-1/2"	6	40	13396ZZ	Terminal Box (includes 42)	1
16	12934A	Seal Assy.	1	41	12381	Screw, 8-32 x 1-1/4"	1
17	12935	Spacer Sleeve	1	42	12383	Grommet, Overload	1
18	12860	O-ring	1	43	13709	Lower Bearing	1
19	12319	Slinger	1	44	13678	Pre-load Spring	1
20	12610	Upper Bearing Assy.	1	45	13747	Lower End Frame	1
21	12326	Water & Oil Seal	1	46	13676ZZ	Fan	1
22	11322	Woodruff Key	3	47	13677ZZ	Retaining Ring	1
23	13080	Bearing Seal Kit (includes items 9-11 & 14-22)	1	48	12490	Tube Spacer	3
24	11444	Lock Washer	3	49	11940A	Thru Bolt	3
25	3135	Screw, 1/4-20 x 1"	3	50	12396	Bottom Cover	1
				51	2466A	Screw, Ground	1
				52	11757B	Foot Tube Assy. (optional)	2

Chart A

Item	Description	Qty	SS-50	SS-75	SS-100	SS-125
33	Rotor & Shaft Assy.	1	13674EZZ	13674GZZ	13274HZZ	13274JZZ
33	Stator Assy.	1	13714	13714A	13714B	13714C
37	Overload Protector	1	13422H	13422K	13422N	13422M

SS-150 / SS-200

Medium Capacity - 1 Phase UL & CSA

208-230/460V 60 Hz

Standard UL	SS-150-34	SS-200-27
Short Body UL	SS-150-38	SS-200-31
CSA Approved	SS-150-35	SS-200-28

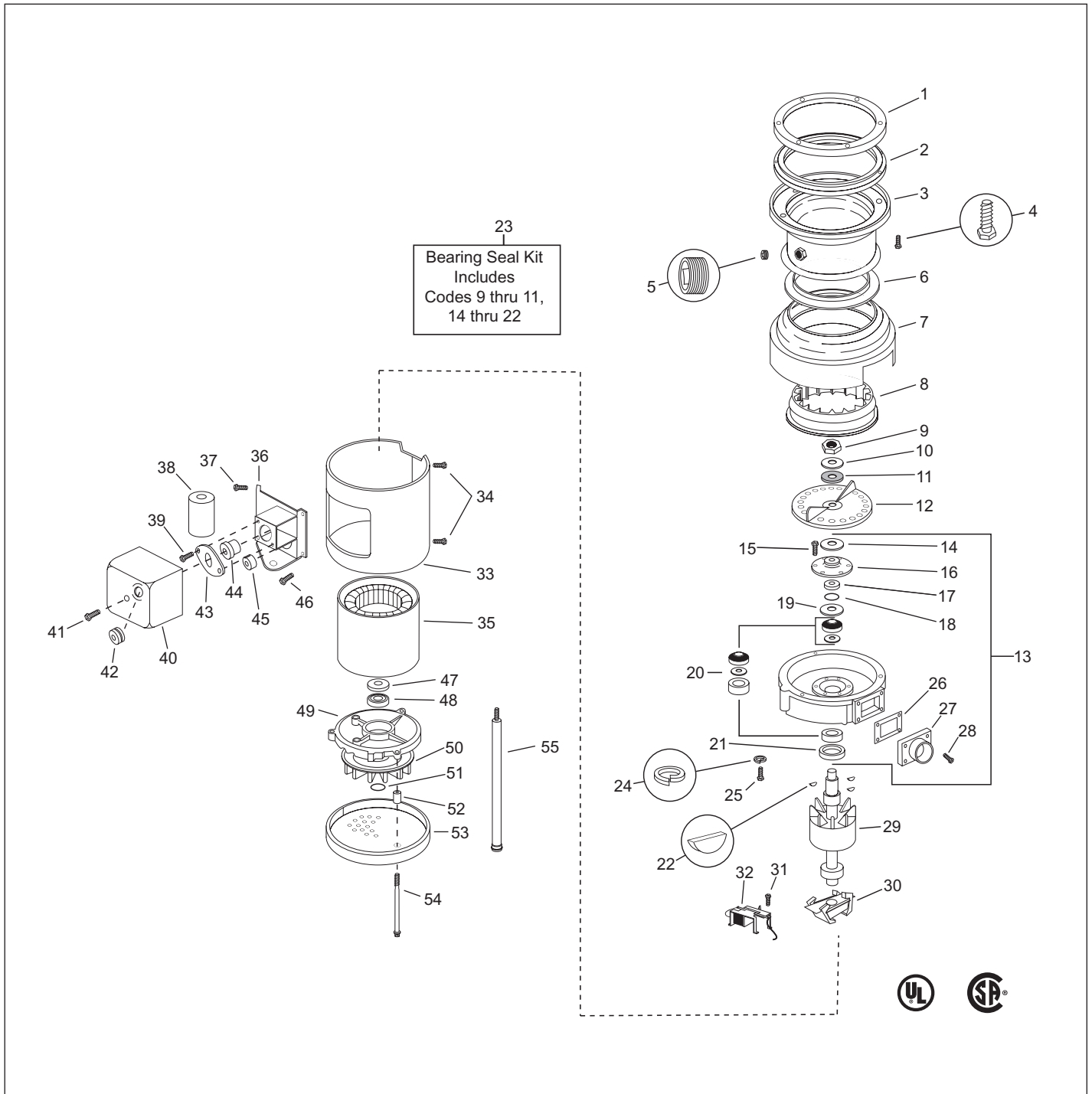

SS-150 / SS-200

Medium Capacity - 1 Phase UL & CSA

115/208-230V 60 Hz

Item	Part No.	Description	Qty	Item	Part No.	Description	Qty
1	11004	Mounting Flange	1	28	13369	Screw, 1/4-20 x 3/4"	4
2	11016	Gasket, Mounting	1	29	See Chart A	Rotor & Shaft Assy. (includes item 30)	1
3	See Chart A	Upper Body Assy.	1	30	Not Repairable	Centrifugal Actuator	1
4	1491	Screw, 1/4-20 x 3/4"	6	31	8221	Screw, 8-32 x 1/2"	2
5	11277	Pipe Plug	1	32	13707	Start Swtich	1
6	11007	Gasket, Shredder	1	33	12426ZZ	Trim Band	1
7	12443ZZ	Body and Cover Assy.	1	34	1836A	Screw, 8-32 x 1/2"	2
8	14663	Stationary Shredder	1	35	See Chart A	Stator Assy.	1
9	11260	Nut	1	36	12433KZZ	Mounting Bracket Assy.	1
10	12445	Washer	1	37	11448	Screw, 8-18 x 1/4"	4
11	12142	Fiber Washer	1	38	11868	Capacitor	1
12	12946ZZ	Rotating Shredder	1	39	8221	Screw, 8-32 x 1/2"	2
13	13723	Upper End Bell Assy (includes items 14-22)	1	40	13396ZZ	Terminal Box Assy.	1
14	12936	Shield	1	41	12381	Screw, 8-32 x 1-1/4"	1
15	1269	Screw, 8-18-1/2"	6	42	12383	Grommet, Overload	1
16	12934A	Seal Assy.	1	43	12378	Clamp, Overload	1
17	12935	Spacer Sleeve	1	44	See Chart A	Overload Protector	1
18	12860	O-ring	1	45	12384	Bushing	1
19	12319	Slinger	1	46	2466A	Screw	1
20	12610	Upper Bearing Assy.	1	47	13709	Lower Bearing	1
21	12326	Water & Oil Seal	1	48	13678	Pre-load Spring	1
22	11322	Woodruff Key	3	49	13710	Lower End Frame	1
23	13080	Bearing Seal Kit (includes items 9-11 & 14-22)	1	50	13676ZZ	Fan	1
24	11444	Lock Washer	6	51	13677ZZ	Retaining Ring	1
25	11524	Screw, 1/4-20 x 1/2"	6	52	12490	Spacer Tube	3
26	11459	Gasket, Tailpipe	1	53	12432	Bottom Cover	1
27	13997	Flange, Tailpipe	1	54	12382A	Thru Bolt	3
				55	11757B	Foot Tube Assy (optional)	2

Chart A

Item	Description	Qty	SS-150	Short SS-150	SS-200	Short SS-200
3	Upper Body Assy	1	11024A	11024C	11024A	11024C
29	Rotor & Shaft Assy. with Centrifugal Actuator	1	13675ZZ	13675ZZ	13675AZZ	13675AZZ
35	Stator Assy.	1	13713D	13713D	13713E	13713E
44	Overload Protector	1	13422S	13422S	13422BA	13422BA

SS-150 / SS-200

Medium Capacity - 3 Phase UL & CSA

208-230/460V 60 Hz

Standard UL	SS-150-36	SS-200-29
Short Body UL	SS-150-39	SS-200-32
CSA Approved	SS-150-37	SS-200-30

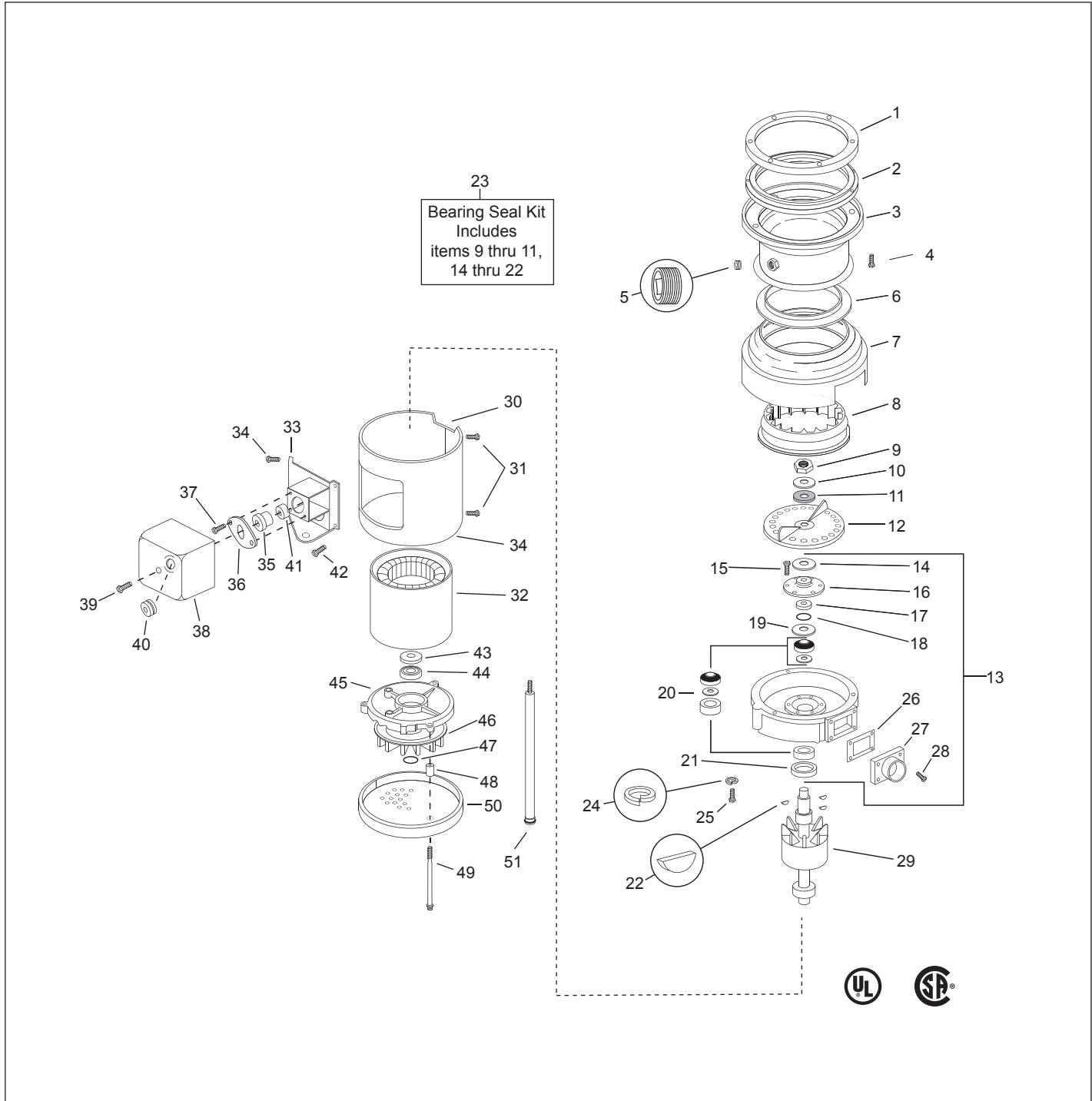

SS-150 / SS-200

Medium Capacity - 3 Phase UL & CSA

208-230/460V 60 Hz

Item	Part No.	Description	Qty	Item	Part No.	Description	Qty
1	11004	Mounting Flange	1	24	11444	Lock Washer	6
2	11016	Gasket, Mounting	1	25	11524	Screw, 1/4-20 x 1/2"	6
3	See Chart A	Upper Body Assy.	1	26	11459	Gasket, Tailpipe	1
4	1491	Screw, 1/4-20 x 3/4"	6	27	13997	Flange, Tailpipe	1
5	11277	Pipe Plug	1	28	13369	Screw, 1/4-20 x 3/4"	4
6	11007	Gasket, Shredder	1	29	See Chart A	Rotor & Shaft Assy.	1
7	12443ZZ	Body and Cover Assy.	1	30	12426ZZ	Trim Band	1
8	14663	Stationary Shredder	1	31	1836A	Screw, 8-32 x 1/2"	2
9	11260	Nut	1	32	See Chart A	Stator Assy.	1
10	12445	Washer	1	33	12433EZZ	Mounting Bracket Assy.	1
11	12142	Fiber Washer	1	34	11448	Screw, 8-18 x 1/4"	4
12	12946ZZ	Rotating Shredder	1	35	See Chart A	Overload Protector	1
13	13723	Upper End Bell Assy (includes items 14-22)	1	36	12378	Clamp, Overload	1
14	12936	Shield	1	37	8221	Screw, 8-32 x 1/2"	2
15	1269	Screw, 8-18 x 1/2"	6	38	13396ZZ	Terminal Box Assy.	1
16	12934A	Seal Assy.	1	39	12381	Screw, 8-32 x 1-1/4"	1
17	12935	Spacer Sleeve	1	40	12383	Grommet, Overload	1
18	12860	O-ring	1	41	12384	Bushing	1
19	12319	Slinger	1	42	2466A	Screw, Ground	1
20	12610	Upper Bearing Assy.	1	43	13709	Lower Bearing	1
21	12326	Water & Oil Seal	1	44	13678	Pre-load Spring	1
22	11322	Woodruff Key	3	45	13747	Lower End Frame	1
23	13080	Bearing Seal Kit (includes items 9-11 & 14-22)	1	46	13676ZZ	Fan	4
				47	13677ZZ	Retaining Ring	1
				48	12490	Tube Spacer.	3
				49	12382A	Thru Bolt	3
				50	12432	Bottom Cover	1
				51	11757B	Foot Tube Assy.	2

Chart A

Item	Description	Qty	SS-150	Short SS-150	SS-200	Short SS-200
3	Upper Body Assy	1	11024A	11024C	11024A	11024C
29	Rotor & Shaft Assy.	1	13675CZZ	13675CZZ	13275DZZ	13275DZZ
32	Stator Assy.	1	13714D	13714D	13714E	13714E
35	Overload Protector	1	13422M	13422M	13422P	13422P

SS-300 / SS-500 / SS-750 / SS-1000

large Capacity - 3 Phase UL & CSA

208-230/460V 60 Hz

Standard UL	SS-300-25	SS-500-28	SS-750-13	SS-1000-10
Short Body UL	SS-300-27	SS-500-30	SS-750-15	SS-1000-12
CSA Approved	SS-300-26	SS-500-29	SS-750-14	SS-1000-11

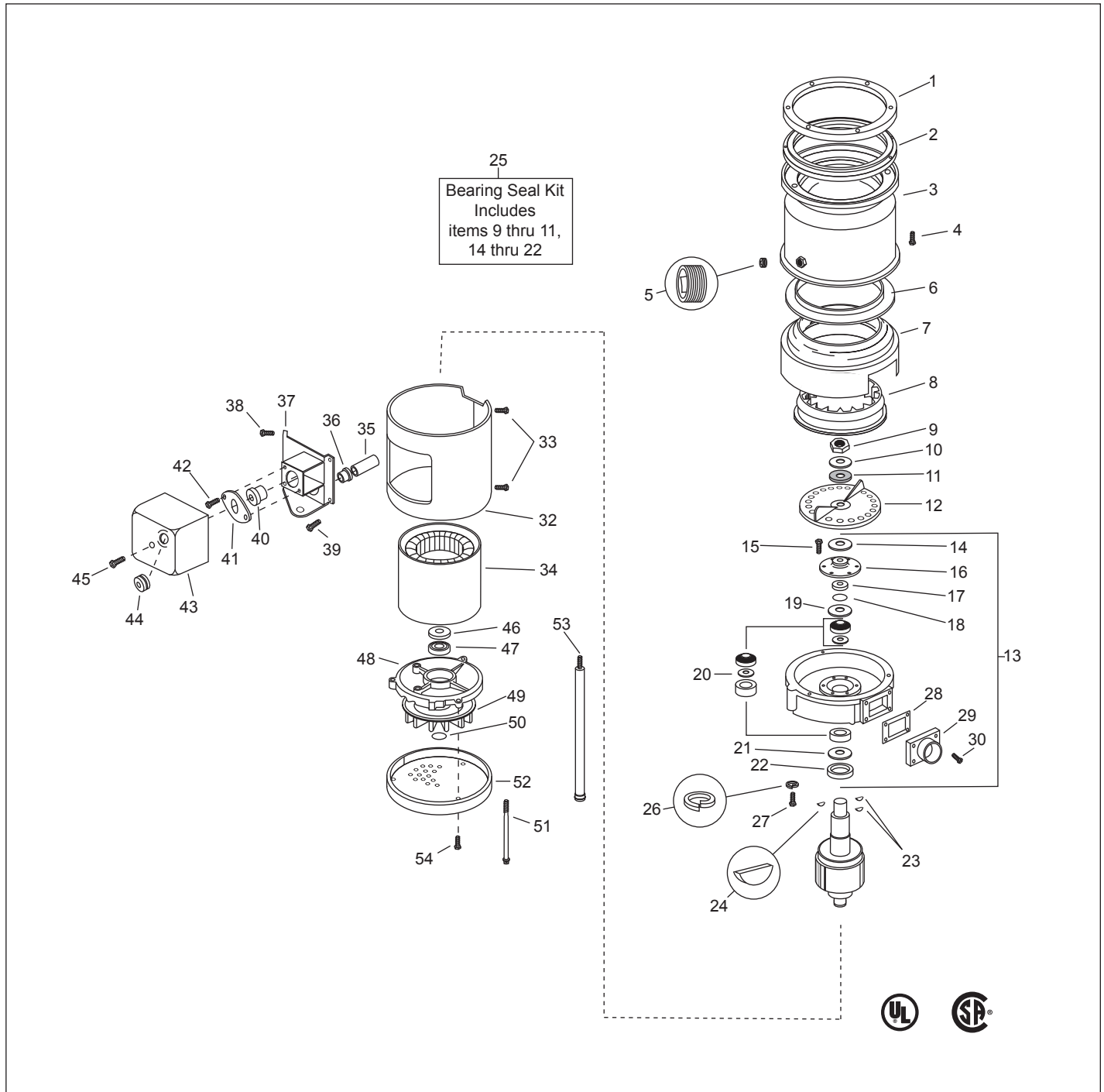

SS-300/SS-500/SS-750/SS-1000

large Capacity - 3 Phase UL & CSA

208-230/460V 60 Hz

Item	Part No.	Description	Qty	Item	Part No.	Description	Qty
1	11004	Mounting Flange	1	26	11444	Lock Washer	6
2	11016	Gasket, Mounting	1	27	11524	Screw, 1/4-20 x 1/2"	6
3a	See Chart A	Upper Body Assy.	1	28	11457	Gasket, Tailpipe	1
3b				29	13998	Flange, Tailpipe	1
4	1491	Screw, 1/4-20 x 3/4"	6	30	3130	Screw	4
5	11277	Pipe Plug	1	31	See Chart A	Rotor & Shaft Assy.	1
6	11008	Gasket, Shredder	1	32	11721ZZ	Trim Band	1
7	11725ZZ	Body and Cover Assy.	1	33	1836A	Screw, 8-32 x 1/2"	2
8	14662	Stationary Shredder	1	34	See Chart A	Stator Assy.	1
9	11255	Nut	1	35	12357ZZ	Insulation Tubing	1
10	11256	Washer	1	36	12384	Bushing	1
11	12143	Fiber Washer	1	37	See Chart A	Bracket	1
12	13273ZZ	Rotating Shredder	1	38	11448	Screw, 8-18 x 1/4"	4
13	13320	Upper End Bell Assy (includes items 14-22)	1	39	2466A	Screw, Ground	1
14	13266	Shield	1	40	See Chart A	Overload Protector	1
15	1269	Screw, 8-18 x 1/2"	12	41	12378	Clamp, Overload	1
16	13260	Seal Assy.	1	42	01836A	Screw	2
17	13265	Spacer Sleeve	1	43	13396ZZ	Terminal Box Assy.	1
18	12859	O-ring	1	44	12383	Grommet, Overload	1
19	11729	Slinger	1	45	12381	Screw	1
20	12638	Upper Bearing Assy.	1	46	12415	Bearing	1
21	11821	Thrust Washer	1	47	13678	Pre-Load Spring	1
22	13398	Water & Oil Seal	1	48	11672	Lower End Frame	1
23	11320	Woodruff Key	2	49	12395	Fan	1
24	11322	Woodruff Key	1	50	12635	Retaining Ring	1
25	13281A	Bearing Seal Kit (includes items 9-11 & 14-22)	1	51	8039	Thru Bolt	4
				52	11748	Bottom Cover	1
				53	11757A	Foot Tube Assy.	3
				54	8221	Screw	3

Chart A

Item	Description	Qty	SS-300	SS-500	SS-750	SS-1000
3a	Upper Body Assy. (standard)	1	11232	11232	11232	11232
3b	Upper Body Assy. (short)	1	11232B	11232B	11232B	11232B
31	Rotor & Shaft Assy.	1	13270ZZ	13270AZZ	13270ZZ	13270AZZ
34	Stator Assy.	1	13079	13079A	13079B	13079C
37	Bracket	1	12433AZZ	12433BZZ	12433BZZ	12433BZZ
40	Overload Protector	1	13422AW	13422B	13422AC	13422AC



*The Emerson logo is a trademark
and a service mark of Emerson Electric Co.
InSinkErator is a division of Emerson
Electric Co. Patents Pending.*



4700 21st Street
Racine, WI 53406-5093
www.insinkerator.com