OWNER'S MANUAL

RIDE+

Electric Bicycle

powered by



BOSCH

Active Line Gen. 3 (25 km/h)
Intuvia - Purion (AUS)



TREK



IT IS IMPORTANT TO READ THE WARNINGS AND INSTRUCTIONS IN THIS MANUAL BEFORE RIDING YOUR NEW BICYCLE.

WELCOME

WELCOMETOOURBIKEFAMILY

Thank you for purchasing your new bike.

We believe in bikes. We make high quality bikes that are built to last. That is why each bike we make comes with a limited lifetime warranty.

We wish you many carefree and enjoyable cycling kilometers with your new bike!

However, if you experience any problems with your bike, do not hesitate to contact your local retailer.

If the problem persists, please call our customer service for a solution.

www.trekbikes.com

CONTENTS

Page

Welcome.....	1
Drive unit.....	3
Intuvia controller.....	11
Purion controller.....	25
Powerpack / Power tube.....	37
Charger.....	49
Contact.....	61

Active Line



Drive Unit 25 km/h

BDU310: 0 275 007 046



BOSCH

en Original instructions

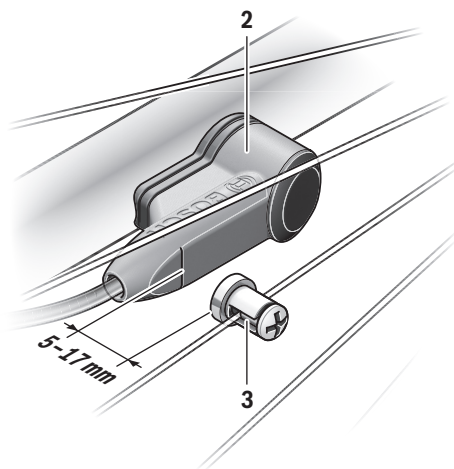

**A**

Safety Notes



Read all safety warnings and all instructions. Failure to follow the warnings and instructions may result in electric shock, fire and/or serious injury.

Save all safety warnings and instructions for future reference.

The term “battery” is used in these instructions to mean all original Bosch eBike rechargeable battery packs.

- ▶ **Do not open the drive unit yourself. The drive unit must be repaired only by qualified experts and only with original spare parts.** This will ensure that the safety of the drive unit is maintained. Unauthorised opening of the drive unit will void warranty claims.
- ▶ **All components mounted to the drive unit and all other components of the eBike drive (e. g., the chainwheel, chainwheel seat, pedals) may be replaced only with identical components or components specifically approved for your eBike by the bicycle manufacturer.** This protects the drive unit against overload and damage.
- ▶ **Remove the battery pack from the eBike before beginning work (e.g. inspection, repair, assembly, maintenance, work on the chain, etc.) on the eBike, transporting it by car or plane, or storing it.** Unintentional activation of the eBike system poses a risk of injury.
- ▶ **The eBike system can be activated by pushing the eBike backwards or by turning the pedals backwards.**
- ▶ **The push-assistance function may only be used when pushing the eBike.** Danger of injury when the wheels of the eBike do not have ground contact while using the push-assistance function.
- ▶ **When the push-assistance function is activated, the pedals turn at the same time.** When the push-assistance function is activated, make sure that there is enough space between your legs and the turning pedals. There is a risk of injury.
- ▶ **Use only original Bosch battery packs approved for your eBike by the manufacturer.** Using other battery packs can lead to injuries and pose a fire hazard. When using other battery packs, Bosch shall not assume any liability and warranty.

- ▶ **After a ride, do not allow your unprotected hands or legs to come into contact with the aluminium housing of the drive unit.** Under extreme conditions, such as continuously high torques at low travel speeds, or when riding up hills or carrying loads, very high temperatures may be reached on the aluminium housing.

The temperatures that may be reached at the drive unit housing are influenced by the following factors:

- Ambient temperature
- Ride profile (route/gradient)
- Ride duration
- Assistance modes
- User behaviour (personal effort)
- Total weight (rider, eBike, luggage)
- Motor cover on the drive unit
- Heat dissipation properties of the bicycle frame
- Type of drive unit and type of gear-shifting

- ▶ **Do not make any modifications to your eBike system or fit any other products which would be suitable for increasing the performance of your eBike system.** This normally reduces the lifetime of the system and risks damage to the drive unit and the bike. There is also a risk of losing the guarantee and warranty claims on the bike you have purchased. By handling the system improperly you are also endangering your safety and that of other road users, thus running the risk of high personal liability costs and possibly even criminal prosecution in the event of accidents attributable to manipulation.
- ▶ **Please observe all national regulations on registering and using eBikes.**
- ▶ **Read and observe the safety warnings and instructions in all operating instructions of the eBike system and in the operating instructions of your eBike.**

Product Description and Specifications

Intended Use

The drive unit is intended only for driving your eBike and must not be used for other purposes.

In addition to the functions shown here, changes to software relating to troubleshooting and functional enhancements may be introduced at any time.

Product Features

The numbering of the components shown refers to the illustrations on the graphic pages at the beginning of the manual. Individual illustrations in these operating instructions may differ slightly from the actual circumstances depending on the equipment of your eBike.

- 1 Drive unit Active Line
- 2 Speed sensor
- 3 Spoke magnet of the speed sensor

Technical Data

Drive Unit		Active Line
Article number		0 275 007 046
Rated continuous output	W	250
Torque at drive, max.	Nm	40
Rated voltage	V $\overline{---}$	36
Operating temperature	°C	- 5 ... + 40
Storage temperature	°C	- 10 ... + 50
Degree of protection		IP 54 (dust and splash water protected)
Weight, approx.	kg	3
Bosch eBike system uses FreeRTOS (see www.freertos.org)		

Bike lights ¹⁾		
Voltage, approx. ²⁾	V $\overline{---}$	12
Maximum output		
– Front light	W	17.4
– Taillight	W	0.6

1) Not possible via the eBike battery pack in all country-specific versions, depending on the statutory regulations

2) When changing the bulbs, ensure that the bulbs are compatible with the Bosch eBike system (ask your bicycle dealer) and that the specified voltage matches. Bulbs must be replaced only with bulbs of the same voltage.

► **Incorrectly inserted bulbs can be destroyed!**

Assembly

Inserting and removing the battery pack

For inserting and removing the eBike battery pack in/from the eBike, please read and observe the battery pack operating instructions.

Checking the Speed Sensor (see figure A)

The speed sensor **2** and its spoke magnet **3** must be mounted in such a manner that the spoke magnet, after a turn of the wheel, moves past the speed sensor with a clearance of at least 5 mm, yet no more than 17 mm.

Note: If the distance between speed sensor **2** and spoke magnet **3** is too small or too large, or if the speed sensor **2** is not properly connected, the speed indication will fail, and the eBike drive unit will operate in emergency mode.

In this case, loosen the screw of the spoke magnet **3** and fasten the spoke magnet to the spoke in such a manner that it runs past the mark of the speed sensor at the correct clearance. If the speed is still not being indicated in the speed indication after this, please contact an authorised bicycle dealer.

Operation

Initial Operation

Requirements

The eBike system can only be activated when the following requirements are met:

- A sufficiently charged battery pack is inserted (see battery pack operating instructions).
- The on-board computer is properly inserted in the holder (see on-board computer operating instructions).
- The speed sensor is connected properly (see "Checking the Speed Sensor", page English – 2).

Switching the eBike System On/Off

Options for **switching on** the eBike system:

- If the on-board computer is already switched on when you insert it into the holder, then the eBike system will be switched on automatically.
- With the on-board computer and the eBike battery pack inserted, briefly press the On/Off button of the on-board computer (see on-board computer operating instructions).
- With the on-board computer inserted, push the On/Off button on the eBike battery (bicycle manufacturer solutions are possible whereby there is no access to the battery On/Off button; see the battery operating instructions).

The drive is activated as soon as you step on the pedals (except when in the push aid feature, see "Switching the Push-assistance mode On/Off", page English – 3). The motor output depends on the settings of the assistance level on the on-board computer.

As soon as you stop pedaling when in normal operation, or as soon as you have reached a speed of 25 km/h, the assistance from the eBike drive is switched off. The drive is automatically re-activated as soon you start pedaling again and the speed is below 25 km/h.

Options for **switching off** the eBike system:

- Press the On/Off button of the on-board computer.
- Switch off the eBike battery using its On/Off button (bicycle manufacturer-specific solutions are possible whereby there is no access to the battery On/Off button; see the bicycle manufacturer operating instructions).
- Remove the on-board computer out of its holder.

If the eBike is not moved **and** no button is pressed on the on-board computer for 10 minutes, the eBike system will shut down automatically in order to save energy.

eShift (optional)

eShift is the integration of electronic gear shifting systems into the eBike system. The eShift components are electrically connected to the drive unit by the manufacturer. The separate operating instructions describe how to operate the electronic gear-shifting systems.

Setting the Assistance Level

On the on-board computer you can set how much the eBike drive assists you while pedalling. The assistance level can be changed at any time, even while cycling.

Note: For individual versions, it is possible that the assistance level is pre-set and cannot be changed. It is also possible that less assistance levels are available for selection than listed here.

The following assistance levels (max.) are available:

- **“OFF”**: The motor assistance is switched off, and the eBike can be moved as a normal bicycle only by pedalling. The push assistance cannot be activated in this assistance level.
- **“ECO”**: Effective assistance at maximum efficiency for maximum cruising range
- **“TOUR”**: Uniform assistance, for touring with long cruising range
- **“SPORT”**: Powerful assistance for sportive riding off road as well as for urban traffic
- **“TURBO”**: Maximum assistance, supporting highest cadence for sportive riding

The motor output requested appears on the display of the on-board computer (not on Purion). The maximum motor output depends on the selected assistance level.

Assistance Level	Assistance Factor*
“ECO”	40%
“TOUR”	100%
“SPORT”	170%
“TURBO”	250%

* The assistance factor may vary on the individual versions.

Switching the Push-assistance mode On/Off

The push-assistance feature makes it easier to push the eBike. The speed in this function depends on the set gear and cannot exceed 6 km/h (max.). The lower the set gear, the lower the speed in the push-assistance function (at full output).

► **The push-assistance function may only be used when pushing the eBike.** Danger of injury when the wheels of the eBike do not have ground contact while using the push-assistance function.

To **activate** the push-assistance function, briefly press button **“WALK”** on your on-board computer. After activation, press button **“+”** within 3 s and keep it pressed. The eBike drive is switched on.

Note: The push assistance cannot be activated in the **“OFF”** assistance level.

The push assistance is **switched off** as soon as one of the following occurs:

- You release the **“+”** button;
- The wheels of the eBike are prevented from turning (e.g. by braking or being hit by your leg);
- The speed exceeds 6 km/h.

Note: On some systems the push-assistance function can be started directly by pressing the **“WALK”** button.

Depending on the statutory specifications in some countries, the push-assistance function may vary by region.

Switching bike lights on/off

In the version which has the bike lights powered by the eBike system, the front and rear lights can be switched on and off at the same time via the on-board computer.

Notes on Riding with the eBike System

When does the eBike Drive Unit Operate?

The eBike drive unit assists you when riding, as long as you step into the pedals. Without pedalling, there is no assistance. The motor output always depends on the amount of your pedaling power.

When applying less pedaling power, the assistance or support will be lower than when applying a lot of pedaling power. This applies independent of the assistance Level.

The eBike drive automatically switches off at speeds in excess of 25 km/h. When the speed falls below 25 km/h, the drive is automatically available again.

An exception applies to the push-assistance function, in which the eBike can be pushed at low speed without pedalling. The pedals may also rotate when the push assistance is used.

The eBike can also be ridden as a normal bicycle without assistance at any time, by either switching off the eBike system or setting the assistance level to **“OFF”**. The same applies when the battery pack is empty.

Interaction of the eBike System with the Bicycle Gears

The bicycle gears should be used as with a normal bicycle, even with eBike motor assistance (please observe the operating instructions of your eBike).

Independent of the type of gearing, it is recommended to briefly interrupt the pedaling while changing gears. This makes changing gears easier and reduces the wear of the drive train.

By selecting the right gear, you can increase the speed and range with the same pedaling effort.

Gathering First Experience

It is recommended to gather first experience with the eBike away from roads with heavy traffic.

Test the various assistance levels. Start with the lowest assistance level. As soon as you feel confident, you can ride your eBike in traffic like any other bike.

Test the operating range of your eBike under different conditions before planning longer and more challenging rides.

Influences on the Operating Range

The range is affected by a number of factors, such as:

- Assistance level
- Speed
- Gear changing behaviour
- Tyre type and tyre pressure
- Age and condition of the battery
- Route profile (gradients) and conditions (road surface)
- Headwind and ambient temperature
- Weight of eBike, driver and luggage.

For this reason, it is not possible to precisely predict the range before and during a trip. General rules:

- With the **same** assistance level on the eBike drive: The less energy you need to exert in order to reach a certain speed (e.g. by changing gears optimally), the less energy the eBike drive will consume and the higher the range per battery charge will be.
- The **higher** the assistance level under otherwise same conditions, the lower the range.

Careful Handling of the eBike

Please observe the operating and storage temperatures of the eBike components. Protect the drive unit, on-board computer and battery against extreme temperatures (e.g. from intense sunlight without adequate ventilation). The components (especially the battery pack) can become damaged through extreme temperatures.

Maintenance and Service

Maintenance and Cleaning

When changing the bulbs, ensure that the bulbs are compatible with the Bosch eBike system (ask your bicycle dealer) and that the specified voltage matches. Bulbs must be replaced only with bulbs of the same voltage.

Do not immerse any components, including the drive unit, in water or clean them with pressurised water.

Have your eBike system checked by an expert at least once a year (including mechanical parts, up-to-dateness of system software).

For service or repairs on the eBike, please refer to an authorised bicycle dealer.

After-sales Service and Application Service

In case of questions concerning the eBike system and its components, please refer to an authorised Bosch eBike dealer.

For contact data of authorised Bosch eBike dealers, please refer to www.bosch-ebike.com

Disposal



The drive unit, on-board computer including operating unit, battery pack, speed sensor, accessories and packaging should be disposed of in an environmentally correct manner.

Do not dispose of eBikes and their components into household waste!

Only for EC countries:



According to the European Guideline 2012/19/EU, electrical devices/tools that are no longer usable, and according to the European Guideline 2006/66/EC, defective or used battery packs/batteries, must be collected separately and disposed of in an environmentally correct manner.

Subject to change without notice.

Active Line

Robert Bosch GmbH

Bosch eBike Systems
72703 Reutlingen
GERMANY

www.bosch-ebike.com

0 275 007 AD4 (2017.04) T / 52 WEU

Active Line



Intuvia

BUI251: 1 270 020 906

BUI255: 1 270 020 909



BOSCH

en Original instructions



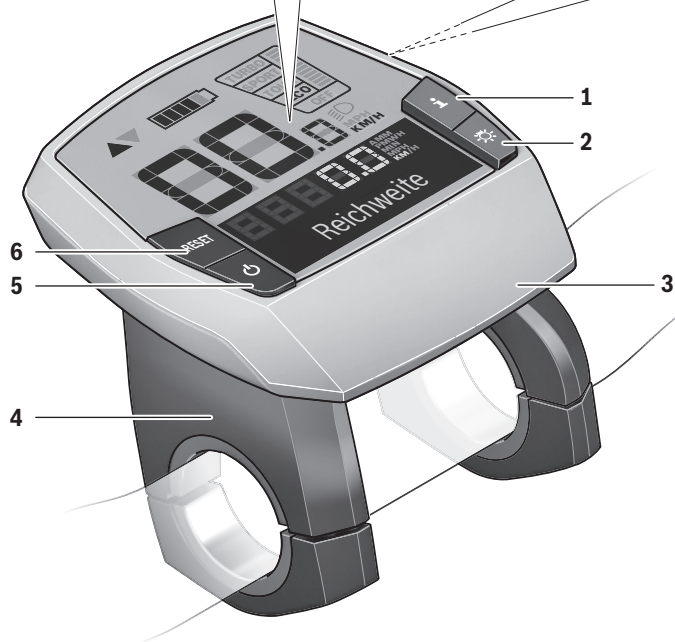
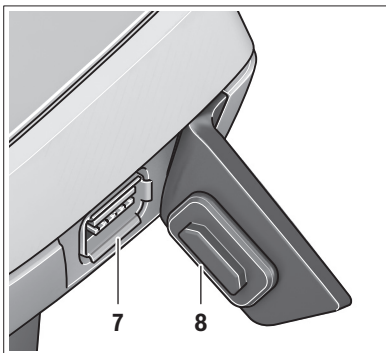
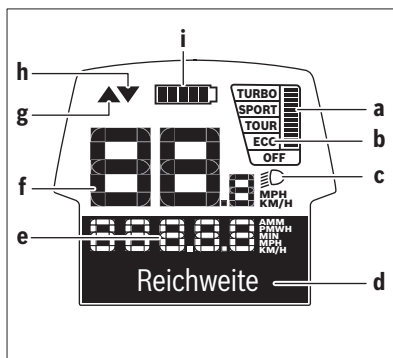

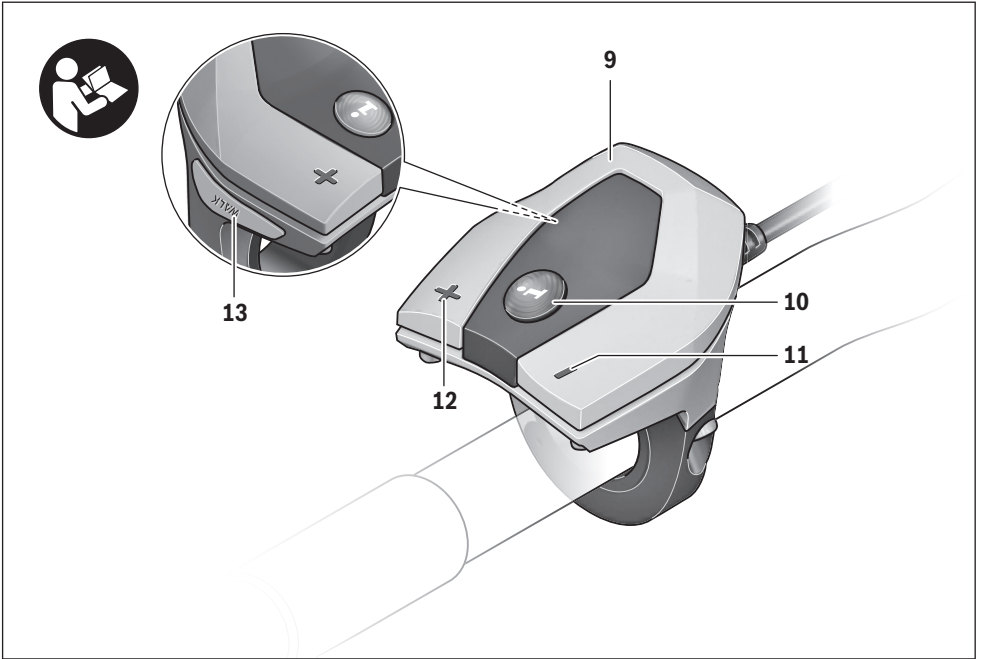

A

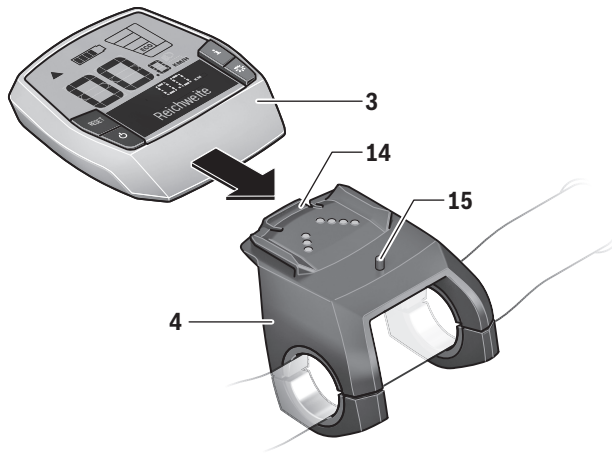

Safety Notes



Read all safety warnings and all instructions. Failure to follow the warnings and instructions may result in electric shock, fire and/or serious injury.

Save all safety warnings and instructions for future reference.

The term “battery” is used in these instructions to mean all original Bosch eBike rechargeable battery packs.

- ▶ **Do not use the on-board computer as a handle.** Lifting the eBike up by the on-board computer can cause irreparable damage to the on-board computer.
- ▶ **Make sure to not be distracted by the display of the on-board computer.** If you do not focus exclusively on the traffic, you risk being involved in an accident. If you want to make entries in your on-board computer other than switching the assistance level, stop and enter the appropriate data.
- ▶ **Read and observe the safety warnings and instructions in all operating instructions of the eBike system and in the operating instructions of your eBike.**

Product Description and Specifications

Intended Use

The Intuvia on-board computer is designed to control Bosch eBike systems and display riding data.

In addition to the functions shown here, changes to software relating to troubleshooting and functional enhancements may be introduced at any time.

Product Features

The numbering of the components shown refers to the illustrations on the graphic pages at the beginning of the manual. Individual illustrations in these operating instructions may differ slightly from the actual circumstances depending on the equipment of your eBike.

- 1 Display-function button “I”
- 2 Bike lights button
- 3 On-board computer
- 4 Holder for on-board computer
- 5 On/Off button for on-board computer
- 6 “RESET” button

- 7 USB port
- 8 Protective cap of USB port
- 9 Operating unit
- 10 Display-function button “I” on the operating unit
- 11 Decrease assistance level/scroll down button “-”
- 12 Increase assistance level/scroll up button “+”
- 13 Push-assistance button “WALK”
- 14 Lock latch for on-board computer
- 15 Locking screw for on-board computer
USB charging cable (Micro A – Micro B)*

* not illustrated; available as accessory

Display elements of on-board computer

- a Drive unit assistance indicator
- b Assistance-level indicator
- c Light indicator
- d Text indication
- e Value indication
- f Speed indication
- g Shift recommendation: higher gear
- h Shift recommendation: lower gear
- i Battery charge-control indicator

Technical Data

On-board computer		Intuvia
Article number		1 270 020 906/909
Max. charging current, USB connection	mA	500
Charging voltage, USB connection	V	5
USB charging cable ¹⁾		1 270 016 360
Operating temperature	°C	- 5 ... + 40
Storage temperature	°C	- 10 ... + 50
Charging temperature	°C	0 ... + 40
Internal lithium-ion battery	V	3.7
	mAh	230
Protection type ²⁾		IP 54 (dust and splash water protected)
Weight, approx.	kg	0.15

1) Not included in standard scope of delivery
2) When USB cover is closed

Bosch eBike system uses FreeRTOS (see www.freertos.org)

Assembly

Inserting and removing the battery pack

For inserting and removing the eBike battery pack in/from the eBike, please read and observe the battery pack operating instructions.

Inserting and removing the on-board computer (see figure A)

To **insert** the on-board computer **3**, slide it from the front into the holder **4**.

To **remove** the on-board computer **3**, press the lock latch **14** and slide the on-board computer toward the front out of the holder **4**.

► Remove the on-board computer when you park the eBike.

It is possible to secure the on-board computer against removal in the holder. To do so, remove the holder **4** from the handlebar. Put the on-board computer in the holder. Screw the locking screw **15** (thread M3, 8 mm long) from below into the thread provided in the holder. Mount the holder back onto the handlebar.

Note: The locking screw is not designed to prevent theft.

Operation

Initial Operation

Requirements

The eBike system can only be activated when the following requirements are met:

- A sufficiently charged battery pack is inserted (see battery pack operating instructions).
- The on-board computer is properly inserted in the holder (see “Inserting and removing the on-board computer”, page English – 2).
- The speed sensor is connected properly (see drive unit operating instructions).

Switching the eBike System On/Off

Options for **switching on** the eBike system:

- If the on-board computer is already switched on when you insert it into the holder, then the eBike system will be switched on automatically.
- When the on-board computer and the eBike battery pack are inserted, briefly press the On/Off button **5** of the on-board computer.
- With the on-board computer inserted, push the On/Off button on the eBike battery (bicycle manufacturer solutions are possible whereby there is no access to the battery On/Off button; see the battery operating instructions).

The drive is activated as soon as you step on the pedals (except for in the push assistance function or in assistance level “OFF”). The motor output depends on the settings of the assistance level on the on-board computer. As soon as the system is activated, “**Active Line/Performance Line**” will appear briefly on the display.

As soon as you stop pedaling when in normal operation, or as soon as you have reached a speed of 25/45 km/h, the assistance from the eBike drive is switched off. The drive is automatically re-activated as soon you start pedaling again and the speed is below 25/45 km/h.

Options for **switching off** the eBike system:

- Press the On/Off button **5** of the on-board computer.
- Switch off the eBike battery using its On/Off button (bicycle manufacturer-specific solutions are possible whereby there is no access to the battery On/Off button; see the bicycle manufacturer operating instructions).
- Remove the on-board computer out of its holder.

If the eBike is not moved **and** no button is pressed on the on-board computer for 10 minutes, the eBike system will shut down automatically in order to save energy.

eShift (optional)

eShift is the integration of electronic gear shifting systems into the eBike system. The eShift components are electrically connected to the drive unit by the manufacturer. The separate operating instructions describe how to operate the electronic gear-shifting systems.

Displays and configurations of the on-board computer

Energy supply of the on-board computer

If the on-board computer is in the holder **4**, a sufficiently charged battery pack is inserted in the eBike and the eBike system is turned on, then the on-board computer is powered by the battery pack of the eBike.

If the on-board computer is removed from the holder **4**, the energy is supplied via an internal battery pack. If the internal battery pack is weak when the on-board computer is switched on, “**Attach to bike**” will appear in text indication **d** for 3 s. The on-board computer will then turn off again.

To charge the internal battery pack, put the on-board computer back in the holder **4** (when a battery pack is inserted in the eBike). Switch the eBike battery pack on by its On/Off button (see battery pack operating instructions).

You can also charge the on-board computer via the USB port. Open the protective cap **8**. Connect the USB port **7** of the on-board computer via a suitable USB cable to a standard USB charger or the USB port of a computer (5 V charging voltage, max. 500 mA charging current). “**USB connected**” will appear in text indication **d** of the on-board computer.

Switching on/shutting down the on-board computer

To **switch on** the on-board computer, briefly press the On/Off button **5**. The on-board computer can also be switched on when it is not inserted in the holder (if the internal battery pack is sufficiently charged).

To **switch off** the on-board computer, press the On/Off button **5**.

If the on-board computer is not inserted in the holder, it automatically switches off after 1 minute to save energy if no button is pressed.

► **If you are not going to be using your eBike for several weeks, remove the on-board computer from its mount.**

Store the on-board computer in a dry environment at room temperature. Regularly recharge the on-board computer's battery (at least every 3 months).

Battery Charge-control Indicator

The battery charge-control indicator **i** displays the charge level of the eBike battery pack, not that of the on-board computer's internal battery pack. The charge level of the eBike battery pack can also be checked on the LEDs of the battery pack itself.

On indicator **i**, each bar of the battery pack symbol is equivalent to a capacity of approx. 20 %:

 The eBike battery pack is fully charged.

 The eBike battery pack should be recharged.

 The LEDs of the charge-control indicator on the battery pack extinguish. The capacity for assisting the drive has been used up, and assistance is gently switched off. The remaining capacity is made available for the lighting and the on-board computer. The indicator flashes.

The capacity of the eBike battery pack is enough for about 2 hours of lighting. This does not account for other consumers (e.g. automatic gearbox, charging external devices at the USB port).

If the on-board computer is removed from the holder **4**, the last displayed battery charge level is saved.

If an eBike is operated with two battery packs, the battery charge-control indicator **i** displays the level of **both** battery packs.

 If an eBike has two battery packs inserted into it and both battery packs are charged on the bike, the charging progress of both battery packs will be indicated on the display (the left-hand battery pack is being charged in the illustration). You can tell by the flashing indicator on the battery pack which of the two battery packs is being charged.

Setting the Assistance Level

On the operating unit **9** you can set how much the eBike drive assists you while pedalling. The assistance level can be changed at any time, even while cycling.

Note: For individual versions, it is possible that the assistance level is pre-set and cannot be changed. It is also possible that less assistance levels are available for selection than listed here.

If the manufacturer has configured the eBike with “**eMTB Mode**” and an Intuvia on-board computer is being used on the bicycle, “**eMTB Mode**” will appear briefly on the display when the “**SPORT**” assistance level is selected. In “**eMTB Mode**”, the assistance factor and torque are dynamically adjusted as a function of the force you exert on the pedals. “**eMTB Mode**” is only available for Performance Line CX drives.

The following assistance levels (max.) are available:

- “**OFF**”: The motor assistance is switched off, and the eBike can be moved as a normal bicycle only by pedalling. The push assistance cannot be activated in this assistance level.
- “**ECO**”: Effective assistance at maximum efficiency for maximum cruising range
- “**TOUR**”: Uniform assistance, for touring with long cruising range
- “**SPORT**”/“**eMTB**”:
 “**SPORT**”: Powerful assistance for sportive riding off road as well as for urban traffic
 “**eMTB**”: Optimal assistance whatever the terrain, rapid acceleration when starting from a standstill, improved dynamics and top performance.
- “**TURBO**”: Maximum assistance, supporting highest cadence for sportive riding

To **increase** the assistance level, press the “**+**” **12** button on the operating unit until the desired assistance level appears in the display **b**. To **decrease** the assistance level, press the button “**-**” **11**.

The requested motor output is displayed in indicator **a**. The maximum motor output depends on the selected assistance level.

When the on-board computer is removed from the holder **4**, the last indicated assistance level is stored; the motor-output indicator **a** remains empty.

Interaction of the eBike System with the Bicycle Gears

The bicycle gears should be used as with a normal bicycle, even with eBike motor assistance (please observe the operating instructions of your eBike).

Independent of the type of gearing, it is recommended to briefly interrupt the pedaling while changing gears. This makes changing gears easier and reduces the wear of the drive train.

By selecting the right gear, you can increase the speed and range with the same pedaling effort.

For this reason, follow the shift recommendations provided by indications **g** and **h** on your display. If indication **g** is displayed, you should shift to a higher gear with lower cadence. If indication **h** is displayed, you should select a lower gear with higher cadence.

Switching bike lights on/off

In the model in which the lighting is powered by the eBike system, the front and rear lights can be switched on and off at the same time via the on-board computer with button **2**.

When the lighting is switched on “**Lights on**” appears and when the lighting is switched off “**Lights off**” appears for approx. 1 s in text indication **d**. The lighting symbol **c** is displayed when the light is on.

Switching the bike light on and off has no effect on the back lighting of the display.

Switching the Push-assistance mode On/Off

The push-assistance feature makes it easier to push the eBike. The speed in this function depends on the set gear and cannot exceed 6 km/h (max.). The lower the set gear, the lower the speed in the push-assistance function (at full output).

► **The push-assistance function may only be used when pushing the eBike.** Danger of injury when the wheels of the eBike do not have ground contact while using the push-assistance function.

To **activate** the push-assistance function, briefly press button “**WALK**” on your on-board computer. After activation, press button “**+**” within 3 s and keep it pressed. The eBike drive is switched on.

Note: The push assistance cannot be activated in the “**OFF**” assistance level.

The push assistance is **switched off** as soon as one of the following occurs:

- You release the “**+**” **12** button;
- The wheels of the eBike are prevented from turning (e.g. by braking or being hit by your leg);
- The speed exceeds 6 km/h.

Note: On some systems the push-assistance function can be started directly by pressing the “**WALK**” button.

The push-assistance function is subject to local regulations; the way it works may therefore differ from the description above.

Displays and configurations of the on-board computer

Speed and Distance Indication

The **speed indication f** always displays the current speed.

The following functions are available in the **function indication** (combination of text indication **d** and value indication **e**):

- “**Clock**”: Current time
- “**Max. speed**”: Maximum speed achieved since the last reset
- “**Avg. speed**”: Average speed achieved since the last reset

- “**Trip time**”: Trip time since the last reset
- “**Range**”: Estimated range of the available battery-pack charge (for constant conditions such as assistance level, route profile, etc.)
- “**Odometer**”: Display of the total distance travelled with the eBike (cannot be reset)
- “**Trip distance**”: Distance covered since the last reset

To **switch between display functions**, press button “**i**” **1** on the on-board computer or button “**i**” **10** on the operating unit repeatedly until the required function is displayed.

To **reset “Trip distance”, “Trip time” and “Avg. speed”**, switch to any of the three functions and then press and hold the “**RESET**” button **6** until the indication is set to zero. This also resets the values of the other two functions.

To **reset the “Max. speed”**, switch to this function and then press and hold the “**RESET**” button **6** until the indication is set to zero.

To **reset “Range”**, switch to this function and then press the “**RESET**” button **6** until the display is reset to the value of the factory setting.

If the on-board computer is removed from the holder **4**, all values of the features are saved and can still be displayed.

Displaying/Adapting Basic Settings

The basic settings can be displayed and changed regardless of whether the on-board computer is inserted in the holder **4** or not. Some settings are visible and changeable only when the operating computer is inserted. Some menu items may be missing depending on the equipment of your eBike.

To access the basic settings menu, press and hold the “**RESET**” button **6** and the “**i**” button **1** until “**Configuration**” is displayed in text indication **d**.

To **switch between the basic settings**, press button “**i**” **1** on the on-board computer repeatedly until the required basic setting is displayed. If the on-board computer is inserted in the holder **4**, you can also press button “**i**” **10** on the operating unit.



To **change the basic settings**, press the On/Off button **5** next to indication “**-**” to reduce or scroll down, or the lighting button **2** next to indication “**+**” to increase or scroll up.

If the on-board computer is inserted in the holder **4**, it is also possible to change using buttons “**-**” **11** and “**+**” **12** on the operating unit.

To exit the function and save a changed setting, press the “**RESET**” button **6** for 3 s.

The following basic settings are available:

- “**- Clock +**”: The current time can be set here. Pressing and holding the setting buttons fast-forwards the setting speed.
- “**- Wheel circum. +**”: You can change this value pre-set by the manufacturer by $\pm 5\%$. This menu item is displayed only when the on-board computer is in the holder.

- “– **English +**”: You can change the language of the text indications. You can choose between German, English, French, Spanish, Italian, Portuguese, Swedish, Dutch and Danish.
- “– **Unit km/mi +**”: The speed and distance can be displayed either in kilometres or miles.
- “– **Time format +**”: The time can be displayed either in the 12 hour or 24 hour format.
- “– **Shift recom. on/off +**”: You can switch the indication of a shift recommendation on and off.
- “**Power-on hours**”: Indicates the total travel duration with the eBike (not changeable).
- “**Displ. vx.x.x.x**”: This is the software version of the display.
- “**DU vx.x.x.x**”: This is the software version of the drive unit. This menu item is displayed only when the on-board computer is in the holder.
- “**DU# xxxxxxxx**”: This is the serial number of the drive unit. This menu item is displayed only when the on-board computer is in the holder.
- “ **Service MM/YYYY**”: This menu item is displayed when the bike manufacturer has set a fixed service appointment.
- “ **Serv. xx km/mi**”: This menu item is displayed when the bike manufacturer has set a fixed service appointment after a certain mileage has been reached.
- “**Bat. vx.x.x.x**”: This is the software version of the battery pack. This menu item is displayed only when the on-board computer is in the holder.
- “**1. Bat. vx.x.x.x**”: When using 2 battery packs this is the software version of one of the battery packs. This menu item is displayed only when the on-board computer is in the holder.
- “**2. Bat. vx.x.x.x**”: When using 2 battery packs this is the software version of the other battery pack. This menu item is displayed only when the on-board computer is in the holder.

Error Code Indication

The components of the eBike system are continuously and automatically monitored. When an error is detected, the respective error code is indicated in text indication **d**.

Press any button on the on-board computer **3** or on the operating unit **9** to return to the standard indication.

Depending on the type of error, the drive unit is automatically shut off, if required. Continued travel without assistance from the drive unit is possible at any time. However, have the eBike checked before attempting new trips.

► **Have all repairs performed only by an authorised bike dealer.**

Code	Cause	Corrective Measure
410	One or more buttons of the on-board computer are blocked.	Check if any buttons are blocked, e.g. from dirt or debris. Clean the buttons, if required.
414	Connection problem of the operating unit	Have connections and contacts checked.
418	One or more buttons of the operating unit are blocked.	Check if any buttons are blocked, e.g. from dirt or debris. Clean the buttons, if required.
419	Configuration error	Restart the system. If the problem persists, contact your Bosch eBike dealer.
422	Connection problem of the drive unit	Have connections and contacts checked.
423	Connection problem of the eBike battery pack	Have connections and contacts checked.
424	Communication error among the components	Have connections and contacts checked.
426	Internal time-out error	Restart the system. If the problem persists, contact your Bosch eBike dealer. In this error status, it is not possible to display or adjust the wheel circumference in the basic settings menu.
430	Internal battery pack of the on-board computer is empty.	Charge the on-board computer (in the holder or via the USB port).
431	Software version error	Restart the system. If the problem persists, contact your Bosch eBike dealer.
440	Internal error of the drive unit	Restart the system. If the problem persists, contact your Bosch eBike dealer.

Code	Cause	Corrective Measure
450	Internal software error	Restart the system. If the problem persists, contact your Bosch eBike dealer.
460	Error at USB connection	Remove the cable from the USB connection of the on-board computer. If the problem persists, contact your Bosch eBike dealer.
490	Internal error of the on-board computer	Have the on-board computer checked.
500	Internal error of the drive unit	Restart the system. If the problem persists, contact your Bosch eBike dealer.
502	Bike lighting error	Check the light and the associated wiring. Restart the system. If the problem persists, contact your Bosch eBike dealer.
503	Error of the speed sensor	Restart the system. If the problem persists, contact your Bosch eBike dealer.
510	Internal sensor error	Restart the system. If the problem persists, contact your Bosch eBike dealer.
511	Internal error of the drive unit	Restart the system. If the problem persists, contact your Bosch eBike dealer.
530	Battery pack error	Switch off the eBike, remove the eBike battery pack and reinsert the eBike battery pack. Restart the system. If the problem persists, contact your Bosch eBike dealer.
531	Configuration error	Restart the system. If the problem persists, contact your Bosch eBike dealer.
540	Temperature error	The eBike is outside of the permissible temperature range. Switch off the eBike system and allow the drive unit to either cool down or heat up to the permissible temperature. Restart the system. If the problem persists, contact your Bosch eBike dealer.
550	An improper load was detected.	Remove load. Restart the system. If the problem persists, contact your Bosch eBike dealer.
580	Software version error	Restart the system. If the problem persists, contact your Bosch eBike dealer.
591	Authentication error	Switch off the eBike system. Remove the battery pack and reinsert it. Restart the system. If the problem persists, contact your Bosch eBike dealer.
592	Incompatible component	Insert a compatible display. If the problem persists, contact your Bosch eBike dealer.
593	Configuration error	Restart the system. If the problem persists, contact your Bosch eBike dealer.
595, 596	Communication error	Check the wiring to the transmission and restart the system. If the problem persists, contact your Bosch eBike dealer.
602	Internal battery pack error while charging	Unplug the charger from the battery pack. Restart the eBike system. Plug the charger into the battery pack. If the problem persists, contact your Bosch eBike dealer.
602	Internal battery pack error	Restart the system. If the problem persists, contact your Bosch eBike dealer.
603	Internal battery pack error	Restart the system. If the problem persists, contact your Bosch eBike dealer.

Code	Cause	Corrective Measure
605	Battery pack temperature error	The eBike is outside of the permissible temperature range. Switch off the eBike system and allow the drive unit to either cool down or heat up to the permissible temperature. Restart the system. If the problem persists, contact your Bosch eBike dealer.
605	Battery pack temperature error while charging	Unplug the charger from the battery pack. Allow the battery pack to cool. If the problem persists, contact your Bosch eBike dealer.
606	External battery pack error	Check the wiring. Restart the system. If the problem persists, contact your Bosch eBike dealer.
610	Battery pack voltage error	Restart the system. If the problem persists, contact your Bosch eBike dealer.
620	Charging error	Replace the charger. Contact your Bosch eBike dealer.
640	Internal battery pack error	Restart the system. If the problem persists, contact your Bosch eBike dealer.
655	Multiple battery pack errors	Switch off the eBike system. Remove the battery pack and reinsert it. Restart the system. If the problem persists, contact your Bosch eBike dealer.
656	Software version error	Contact your Bosch eBike dealer so that he can perform a software update.
7xx	Transmission error	Please observe the operating instructions provided by the transmission manufacturer.
No display	Internal error of the on-board computer	Restart your eBike system by switching it off and back on.

Power Supply of External Devices via USB Connection

With the USB connection, it is possible to operate and charge most devices whose power supply is possible via USB (e.g., various mobile phones).

Prerequisite for charging is that the on-board computer and a sufficiently charged battery pack are inserted in the eBike.

Open the protective cap **8** of the USB port on the on-board computer. Connect the USB connection of the external device to the USB port **7** on the on-board computer using the USB charging cable Micro A – Micro B (available from your Bosch eBike dealer).

Once the consumer has been disconnected, the USB connection must be sealed again carefully with the protective cap **8**.

► **A USB connection is not a waterproof plug-in connection. When riding in the rain, an external device must not be connected and the USB connection must be completely sealed with the protective cap 8.**

Maintenance and Service

Maintenance and Cleaning

Do not immerse any components, including the drive unit, in water or clean them with pressurised water.

Clean your on-board computer using a soft cloth dampened only with water. Do not use any detergents.

Have your eBike system checked by an expert at least once a year (including mechanical parts, up-to-dateness of system software).

The bicycle manufacturer or dealer may also base the service date on the distance travelled and/or a period of time. In this case, the on-board computer will show you every time it is switched on that the service date is due in the text indication **d** by displaying “ Service” for 4 s.

For service or repairs on the eBike, please refer to an authorised bicycle dealer.

After-sales Service and Application Service

In case of questions concerning the eBike system and its components, please refer to an authorised Bosch eBike dealer.

For contact data of authorised Bosch eBike dealers, please refer to www.bosch-ebike.com

Transport

- ▶ **If you transport your eBike attached to the outside of your car, e.g. on a bike rack, remove the on-board computer and the eBike battery to avoid damaging them.** (If the on-board computer cannot be fitted onto a bracket, it is not possible to remove it from the bicycle. In this case, the on-board computer may remain on the bicycle.)

The battery packs are subject to the Dangerous Goods Legislation requirements. Private users can transport undamaged battery packs by road without further requirements.

When being transported by commercial users or third parties (e.g. air transport or forwarding agency), special requirements on packaging and labelling must be observed (e.g. ADR regulations). If necessary, an expert for hazardous materials can be consulted when preparing the item for shipping.

In case of questions concerning transport of the battery packs, please refer to an authorised Bosch eBike dealer. The Bosch eBike dealers can also provide suitable transport packaging.

Disposal



The drive unit, on-board computer including operating unit, battery pack, speed sensor, accessories and packaging should be disposed of in an environmentally correct manner.

Do not dispose of eBikes and their components into household waste!

Only for EC countries:



According to the European Guideline 2012/19/EU, electrical devices/tools that are no longer usable, and according to the European Guideline 2006/66/EC, defective or used battery packs/batteries, must be collected separately and disposed of in an environmentally correct manner.

The integrated battery pack in the on-board computer may only be removed for disposal. Opening the housing shell can destroy the on-board computer.

Please return battery packs and on-board computers that are no longer usable to an authorised bicycle dealer.



Li-ion:

Please observe the instructions in section "Transport", page English – 8.

Subject to change without notice.

en EU Declaration of Conformity

Intuvia

Article number

We declare under our sole responsibility that the stated products comply with all applicable provisions of the directives and regulations listed below and are in conformity with the following standards.
 Technical file at: *

Intuvia

1 270 020 903
 1 270 020 906
 1 270 020 909

2014/30/EU
 2011/65/EU

EN 55022:2010
 EN 55024:2010



BOSCH

* Robert Bosch Power Tools GmbH (PT/ECS)
 70538 Stuttgart
 GERMANY

Claus Fleischer
 Senior Vice President

Gunter Flinspach
 Vice President

ppa C.F. i.v. Flinspach

Bosch eBike Systems, 72703 Reutlingen, GERMANY
 Reutlingen, 01.04.2016

Active Line

Robert Bosch GmbH

Bosch eBike Systems
72703 Reutlingen
GERMANY

www.bosch-ebike.com

1 270 020 XBI (2017.04) T / 99 WEU

Active Line



Purion

BUI210: 1 270 020 916 | 1 270 020 925

BUI215: 1 270 020 917 | 1 270 020 926



BOSCH

en Original instructions



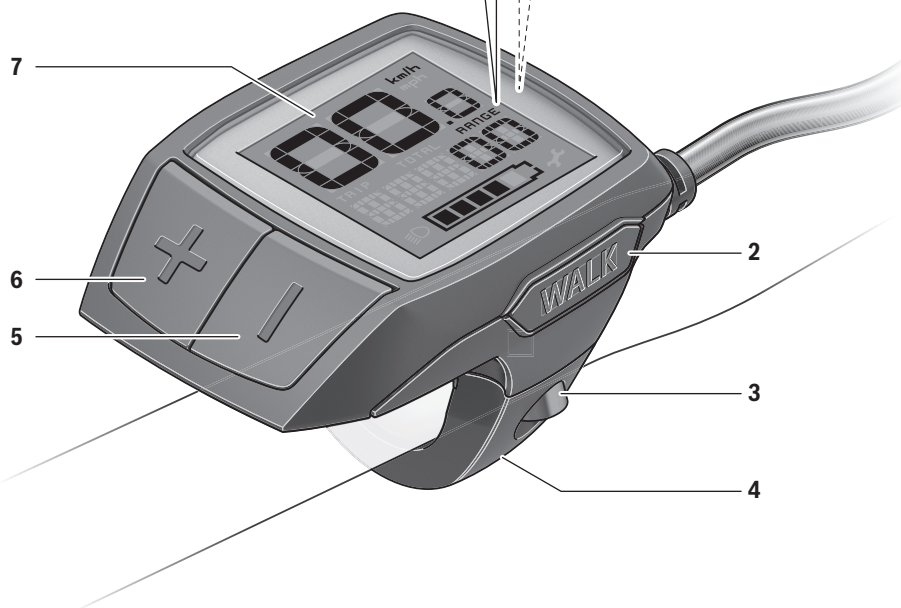
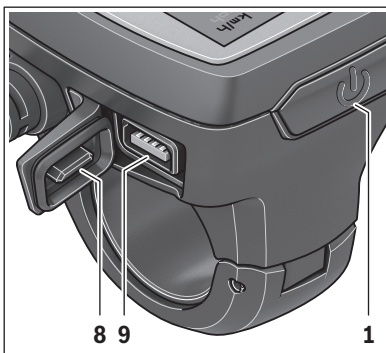
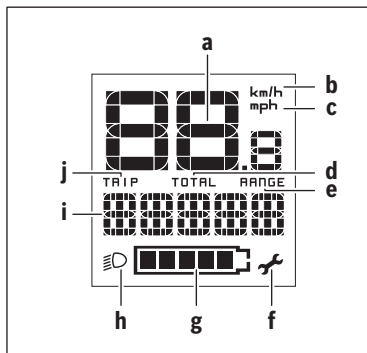

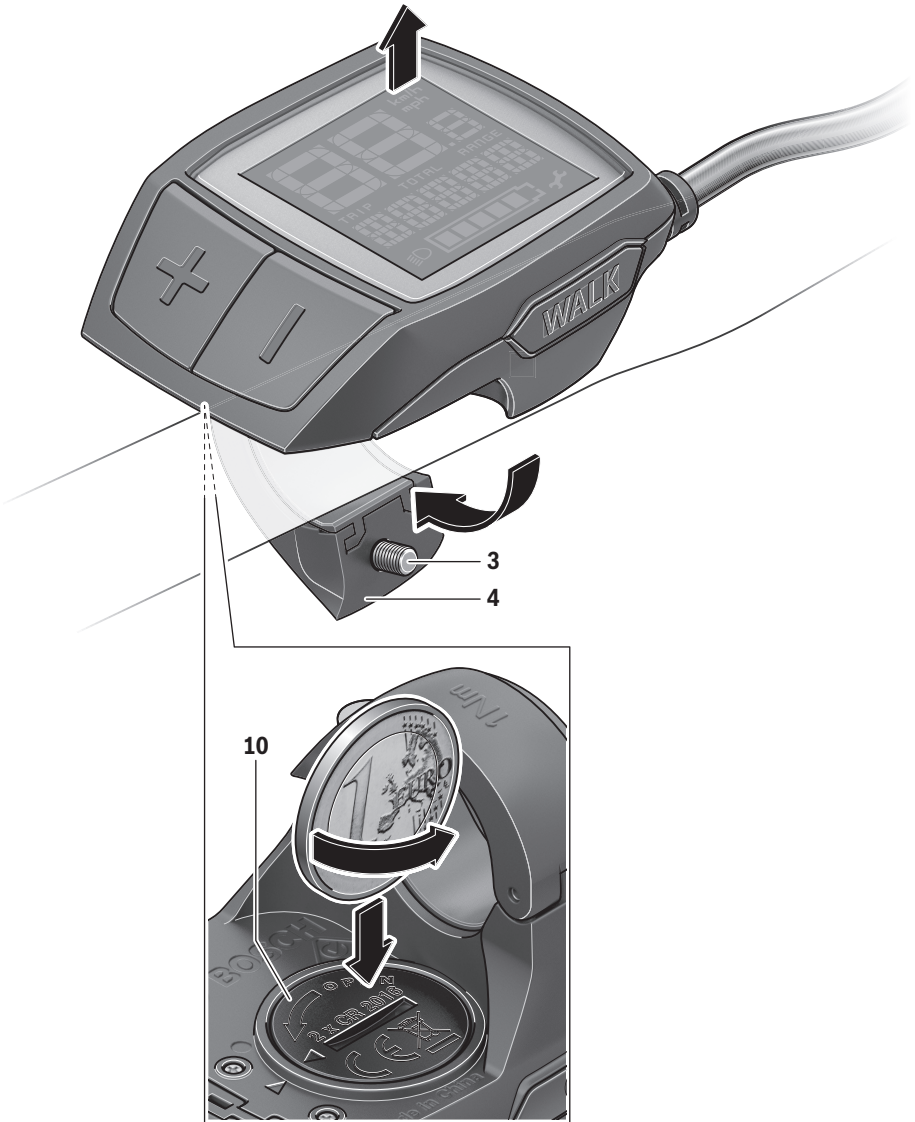
A

Safety Notes



Read all safety warnings and all instructions. Failure to follow the warnings and instructions may result in electric shock, fire and/or serious injury.

Save all safety warnings and instructions for future reference.

The term “battery” is used in these instructions to mean all original Bosch eBike rechargeable battery packs.

- ▶ **Make sure to not be distracted by the display of the on-board computer.** If you do not focus exclusively on the traffic, you risk being involved in an accident.
- ▶ **Read and observe the safety warnings and instructions in all operating instructions of the eBike system and in the operating instructions of your eBike.**

Product Description and Specifications

Intended Use

The Purion on-board computer is designed to control Bosch eBike systems and display riding data.

In addition to the functions shown here, changes to software relating to troubleshooting and functional enhancements may be introduced at any time.

Product Features

The numbering of the components shown refers to the illustrations on the graphic pages at the beginning of the manual. Individual illustrations in these operating instructions may differ slightly from the actual circumstances depending on the equipment of your eBike.

- 1 On/Off button for on-board computer
- 2 Push-assistance button “WALK”
- 3 Fastening screw for on-board computer
- 4 Holder for on-board computer
- 5 Decrease assistance level button “-”
- 6 Increase assistance level button “+”
- 7 Display
- 8 Protective cap of USB port
- 9 USB diagnostic socket (for servicing purposes only)
- 10 Battery lid

Display elements of on-board computer

- a Speed indication
- b km/h unit indicator
- c mph unit indicator
- d Total distance indicator “TOTAL”
- e Range indicator “RANGE”
- f Service indicator
- g Battery charge-control indicator
- h Light indicator
- i Assistance level indicator/value indicator
- j Trip distance indicator “TRIP”

Technical Data

On-board computer	Purion	
Article number		1 270 020 916/925 1 270 020 917/926
Batteries ¹⁾		2 x 3 V CR2016
Operating temperature	°C	-5 ... +40
Storage temperature	°C	-10 ... +50
Protection type ²⁾		IP 54 (dust and splash water protected)
Weight, approx.	kg	0.1
1) We recommend using the batteries offered by Bosch. You can purchase them from your bicycle dealer (part number: 1 270 016 819). 2) When USB cover is closed Bosch eBike system uses FreeRTOS (see www.freertos.org)		

Operation

Initial Operation

Requirements

The eBike system can only be activated when the following requirements are met:

- A sufficiently charged battery pack is inserted (see battery pack operating instructions).
- The speed sensor is connected properly (see drive unit operating instructions).

Switching the eBike System On/Off

Options for **switching on** the eBike system:

- Press the On/Off button **1** of the on-board computer with the eBike battery pack inserted.
- Press the On/Off button of the eBike battery pack (see battery pack operating instructions).

The drive is activated as soon as you step on the pedals (except for in the push assistance function or in assistance level “OFF”). The motor output depends on the settings of the assistance level on the on-board computer.

As soon as you stop pedaling when in normal operation, or as soon as you have reached a speed of 25/45 km/h, the assistance from the eBike drive is switched off. The drive is automatically re-activated as soon you start pedaling again and the speed is below 25/45 km/h.

Options for **switching off** the eBike system:

- Press the On/Off button **1** of the on-board computer.
- Switch off the eBike battery using its On/Off button (bicycle manufacturer-specific solutions are possible where by there is no access to the battery On/Off button; see the bicycle manufacturer operating instructions).

The system shuts down after being switched off; this takes approximately 3 seconds. It cannot be switched back on immediately until shutdown has been completed.



If the eBike is not moved **and** no button is pressed on the on-board computer for 10 minutes, the eBike system will shut down automatically in order to save energy.

Note: Always switch off the eBike system when you park the eBike.

Note: If the batteries of the on-board computer are empty, you can still switch on your eBike using the bike's battery pack. It is, however, recommended that you replace the internal batteries as soon as possible in order to avoid damage.

Displays and configurations of the on-board computer

Symbols and their meaning

Symbol	Explanation
	short button press (less than 1 second)
	medium button press (between 1 second and 2.5 seconds)
	long button press (longer than 2.5 seconds)

Energy supply of the on-board computer

The on-board computer is supplied with voltage by two CR2016 button cells.

Changing the Batteries (see figure A)

If the on-board computer shows “**LOW BAT**” on the display, remove the on-board computer from the handlebars by unscrewing the fastening screw **3** of the on-board computer. Open the battery lid **10** using a suitable coin, remove the used batteries and insert new CR 2016 batteries. You can obtain the batteries recommended by Bosch from your bicycle dealer.

When inserting batteries, pay attention to the correct polarity.

Close the battery compartment again and fasten the on-board computer to your eBike's handlebars using the fastening screw **3**.

Battery Charge-control Indicator

The battery charge-control indicator **g** displays the charge level of the eBike battery pack. The charge level of the eBike battery pack can also be checked on the LEDs of the battery pack itself.

On indicator **g**, each bar of the battery pack symbol is equivalent to a capacity of approx. 20 %:



The eBike battery pack is fully charged.



The eBike battery pack should be recharged.



The LEDs of the charge-control indicator on the battery extinguish. The capacity for assisting the drive has been used up, and assistance is gently switched off. The remaining capacity is made available for the lighting. The indicator flashes.

The capacity of the eBike battery pack is enough for about 2 hours of lighting.

Switching the Push-assistance mode On/Off

The push-assistance feature makes it easier to push the eBike. The speed in this function depends on the set gear and cannot exceed 6 km/h (max.). The lower the set gear, the lower the speed in the push-assistance function (at full output).

► **The push-assistance function may only be used when pushing the eBike.** Danger of injury when the wheels of the eBike do not have ground contact while using the push-assistance function.

To **activate** the push-assistance function, short-press  the button “**WALK**” on your on-board computer. After activation, press button “**+**” within 3 s and keep it pressed. The eBike drive is switched on.

Note: The push assistance cannot be activated in the “**OFF**” assistance level.

The push assistance is **switched off** as soon as one of the following occurs:

- You release the “**+**” **6** button;
- The wheels of the eBike are prevented from turning (e.g. by braking or being hit by your leg);
- The speed exceeds 6 km/h.

Note: On some systems the push-assistance function can be started directly by pressing the “**WALK**” button.

Setting the Assistance Level



On the on-board computer you can set how much the eBike drive assists you while pedalling. The assistance level can be changed at any time, even while cycling.

Note: For individual versions, it is possible that the assistance level is pre-set and cannot be changed. It is also possible that less assistance levels are available for selection than listed here.



When the eBike is configured in “eMTB Mode” by the manufacturer, the assistance level “SPORT” is replaced by “eMTB”. In “eMTB Mode”, the assistance factor and torque are dynamically adjusted as a function of the force you exert on the pedals. “eMTB Mode” is only available for Performance Line CX drives.

The following assistance levels (max.) are available:

- “OFF”: The motor assistance is switched off, and the eBike can be moved as a normal bicycle only by pedalling. The push assistance cannot be activated in this assistance level.
- “ECO”: Effective assistance at maximum efficiency for maximum cruising range
- “TOUR”: Uniform assistance, for touring with long cruising range
- “SPORT”/“eMTB”:
 “SPORT”: Powerful assistance for sportive riding off road as well as for urban traffic
 “eMTB”: Optimal assistance whatever the terrain, rapid acceleration when starting from a standstill, improved dynamics and top performance.
- “TURBO”: Maximum assistance, supporting highest cadence for sportive riding

To **increase** the assistance level, short-press  the button “+” 6 on the on-board computer repeatedly until the required assistance level appears in indicator **i**. To **decrease** the assistance level, short-press  the button “-” 5.

Switching bike lights on/off

In the version which has the bike lights powered by the eBike system, medium-press  the button “+” to switch on the front and rear lights at the same time. To switch off the bike lights, long-press  the button “+”.



The lighting symbol **h** is displayed when the light is on.

Switching the bike light on and off has no effect on the back lighting of the display.



Displays and configurations of the on-board computer

Speed and Distance Indication

The **speed indication a** always displays the current speed.

Indicator **i** always displays the last setting as standard. Repeatedly medium-press  the button “-” to display the trip distance “TRIP”, the total distance “TOTAL” and the range of the battery pack “RANGE” one after the other. (Short-pressing  the button “-” will decrease the assistance level!)

























The trip distance “TRIP” is reset by simultaneously long-pressing  the buttons “+” and “-”. The display will initially show “RESET”. If you continue to press both buttons, the trip distance “TRIP” will be set to “0”.

You can switch the displayed values from kilometres to miles by holding down button “-”  and briefly pressing the On/Off button 1 .

The versions of the subsystems can be displayed for the purposes of servicing. With the system **switched off**, simultaneously press buttons “-” and “+” and then press the On/Off button 1 .

The USB socket is reserved for connecting diagnostic systems. The USB socket does not have any other function.

► **The USB connection must always be completely sealed with the protective cap 8.**

Action	Buttons	Duration
Switch on on-board computer		Any
Switch off on-board computer		Any
Increase assistance	+ 	
Decrease assistance	- 	
Display “TRIP”, “TOTAL”, “RANGE”, assistance modes	- 	
Switch on bike lights	+ 	
Switch off bike lights	+ 	
Reset trip distance	- + 	
Activate push assistance	WALK	1. 
Perform push assistance	+ 	2. Any
Switch from kilometres to miles	-  ⏻ 	1. Hold 2. 
Display the versions 1)2)	- +  ⏻ 	1. Hold 2. 
Set display brightness 3)	- +  ⏻ 	1. Hold 2. 
	- or +	

1) The eBike system must be switched off.

2) The information is shown as scrolling text.

3) The display must be switched off.

Error Code Indication

The components of the eBike system are continuously and automatically monitored. If an error is detected, the corresponding error code will appear in the speed indication **a**.

Depending on the type of error, the drive unit is automatically shut off, if required. Continued travel without assistance from the drive unit is possible at any time. However, have the eBike checked before attempting new trips.

► **Have all repairs performed only by an authorised bike dealer.**

Code	Cause	Corrective Measure
410	One or more buttons of the on-board computer are blocked.	Check if any buttons are blocked, e.g. from dirt or debris. Clean the buttons, if required.
414	Connection problem of the operating unit	Have connections and contacts checked.
418	One or more buttons of the operating unit are blocked.	Check if any buttons are blocked, e.g. from dirt or debris. Clean the buttons, if required.
419	Configuration error	Restart the system. If the problem persists, contact your Bosch eBike dealer.
422	Connection problem of the drive unit	Have connections and contacts checked.
423	Connection problem of the eBike battery pack	Have connections and contacts checked.
424	Communication error among the components	Have connections and contacts checked.
426	Internal time-out error	Restart the system. If the problem persists, contact your Bosch eBike dealer. In this error status, it is not possible to display or adjust the wheel circumference in the basic settings menu.
430	Internal battery pack of the on-board computer is empty.	Charge the on-board computer (in the holder or via the USB port).
431	Software version error	Restart the system. If the problem persists, contact your Bosch eBike dealer.
440	Internal error of the drive unit	Restart the system. If the problem persists, contact your Bosch eBike dealer.
450	Internal software error	Restart the system. If the problem persists, contact your Bosch eBike dealer.
460	Error at USB connection	Remove the cable from the USB connection of the on-board computer. If the problem persists, contact your Bosch eBike dealer.
490	Internal error of the on-board computer	Have the on-board computer checked.
500	Internal error of the drive unit	Restart the system. If the problem persists, contact your Bosch eBike dealer.
502	Bike lighting error	Check the light and the associated wiring. Restart the system. If the problem persists, contact your Bosch eBike dealer.
503	Error of the speed sensor	Restart the system. If the problem persists, contact your Bosch eBike dealer.
510	Internal sensor error	Restart the system. If the problem persists, contact your Bosch eBike dealer.
511	Internal error of the drive unit	Restart the system. If the problem persists, contact your Bosch eBike dealer.
530	Battery pack error	Switch off the eBike, remove the eBike battery pack and reinsert the eBike battery pack. Restart the system. If the problem persists, contact your Bosch eBike dealer.

Code	Cause	Corrective Measure
531	Configuration error	Restart the system. If the problem persists, contact your Bosch eBike dealer.
540	Temperature error	The eBike is outside of the permissible temperature range. Switch off the eBike system and allow the drive unit to either cool down or heat up to the permissible temperature. Restart the system. If the problem persists, contact your Bosch eBike dealer.
550	An improper load was detected.	Remove load. Restart the system. If the problem persists, contact your Bosch eBike dealer.
580	Software version error	Restart the system. If the problem persists, contact your Bosch eBike dealer.
591	Authentication error	Switch off the eBike system. Remove the battery pack and reinsert it. Restart the system. If the problem persists, contact your Bosch eBike dealer.
592	Incompatible component	Insert a compatible display. If the problem persists, contact your Bosch eBike dealer.
593	Configuration error	Restart the system. If the problem persists, contact your Bosch eBike dealer.
595, 596	Communication error	Check the wiring to the transmission and restart the system. If the problem persists, contact your Bosch eBike dealer.
602	Internal battery pack error while charging	Unplug the charger from the battery pack. Restart the eBike system. Plug the charger into the battery pack. If the problem persists, contact your Bosch eBike dealer.
602	Internal battery pack error	Restart the system. If the problem persists, contact your Bosch eBike dealer.
603	Internal battery pack error	Restart the system. If the problem persists, contact your Bosch eBike dealer.
605	Battery pack temperature error	The eBike is outside of the permissible temperature range. Switch off the eBike system and allow the drive unit to either cool down or heat up to the permissible temperature. Restart the system. If the problem persists, contact your Bosch eBike dealer.
605	Battery pack temperature error while charging	Unplug the charger from the battery pack. Allow the battery pack to cool. If the problem persists, contact your Bosch eBike dealer.
606	External battery pack error	Check the wiring. Restart the system. If the problem persists, contact your Bosch eBike dealer.
610	Battery pack voltage error	Restart the system. If the problem persists, contact your Bosch eBike dealer.
620	Charging error	Replace the charger. Contact your Bosch eBike dealer.
640	Internal battery pack error	Restart the system. If the problem persists, contact your Bosch eBike dealer.
655	Multiple battery pack errors	Switch off the eBike system. Remove the battery pack and reinsert it. Restart the system. If the problem persists, contact your Bosch eBike dealer.
656	Software version error	Contact your Bosch eBike dealer so that he can perform a software update.
7xx	Transmission error	Please observe the operating instructions provided by the transmission manufacturer.
No display	Internal error of the on-board computer	Restart your eBike system by switching it off and back on.

Maintenance and Service

Maintenance and Cleaning

Do not immerse any components, including the drive unit, in water or clean them with pressurised water.

Clean your on-board computer using a soft cloth dampened only with water. Do not use any detergents.

Have your eBike system checked by an expert at least once a year (including mechanical parts, up-to-dateness of system software).

The bicycle manufacturer or dealer may also store a distance travelled for the service date in the system. In this case, the on-board computer will show you that the service date is due by displaying f “🔧”.

For service or repairs on the eBike, please refer to an authorised bicycle dealer.

After-sales Service and Application Service

In case of questions concerning the eBike system and its components, please refer to an authorised Bosch eBike dealer.

For contact data of authorised Bosch eBike dealers, please refer to www.bosch-ebike.com

Disposal



The drive unit, on-board computer including operating unit, battery pack, speed sensor, accessories and packaging should be disposed of in an environmentally correct manner.

Do not dispose of eBikes and their components into household waste!

Only for EC countries:



According to the European Guideline 2012/19/EU, electrical devices/tools that are no longer usable, and according to the European Guideline 2006/66/EC, defective or used battery packs/batteries, must be collected separately and disposed of in an environmentally correct manner.

Please return battery packs and on-board computers that are no longer usable to an authorised bicycle dealer.



Subject to change without notice.

en EU Declaration of Conformity

Purion

Article number

We declare under our sole responsibility that the stated products comply with all applicable provisions of the directives and regulations listed below and are in conformity with the following standards.
 Technical file at: *

Purion	1 270 020 916/925	2014/30/EU	EN 55022:2010
	1 270 020 917/926	2011/65/EU	EN 55024:2010
		 BOSCH	* Bosch eBike Systems 72703 Reutlingen GERMANY
		Claus Fleischer Senior Vice President 	Gunter Flinspach Vice President  i. V. Flinspach
		Bosch eBike Systems, 72703 Reutlingen, GERMANY Reutlingen, 01.04.2016	

Active Line

Robert Bosch GmbH

Bosch eBike Systems
72703 Reutlingen
GERMANY

www.bosch-ebike.com

1 270 020 XBP (2017.05) T / 83 WEU

Active Line



PowerPack 300 | 400 | 500 PowerTube 500

BBS240: 0 275 007 547 | BBS245: 0 275 007 548 | BBR240: 0 275 007 513
BBS260: 0 275 007 510 | BBS265: 0 275 007 512 | BBR260: 0 275 007 514 | BBR265: 0 275 007 522
BBS270: 0 275 007 529 | BBS275: 0 275 007 530 | BBR270: 0 275 007 531 | BBR275: 0 275 007 532
BBP280: 0 275 007 539 | BBP281: 0 275 007 540



BOSCH

en Original instructions



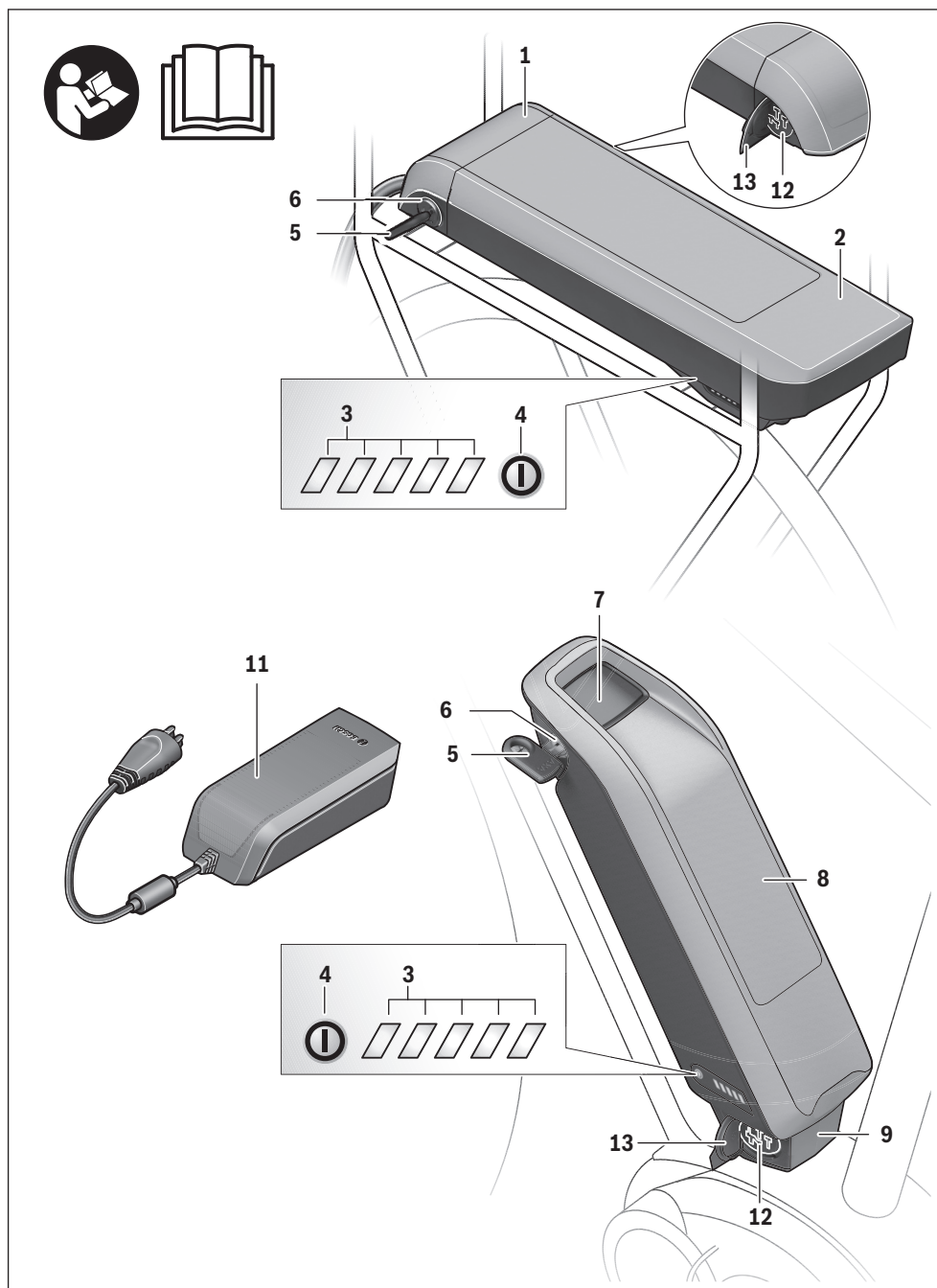

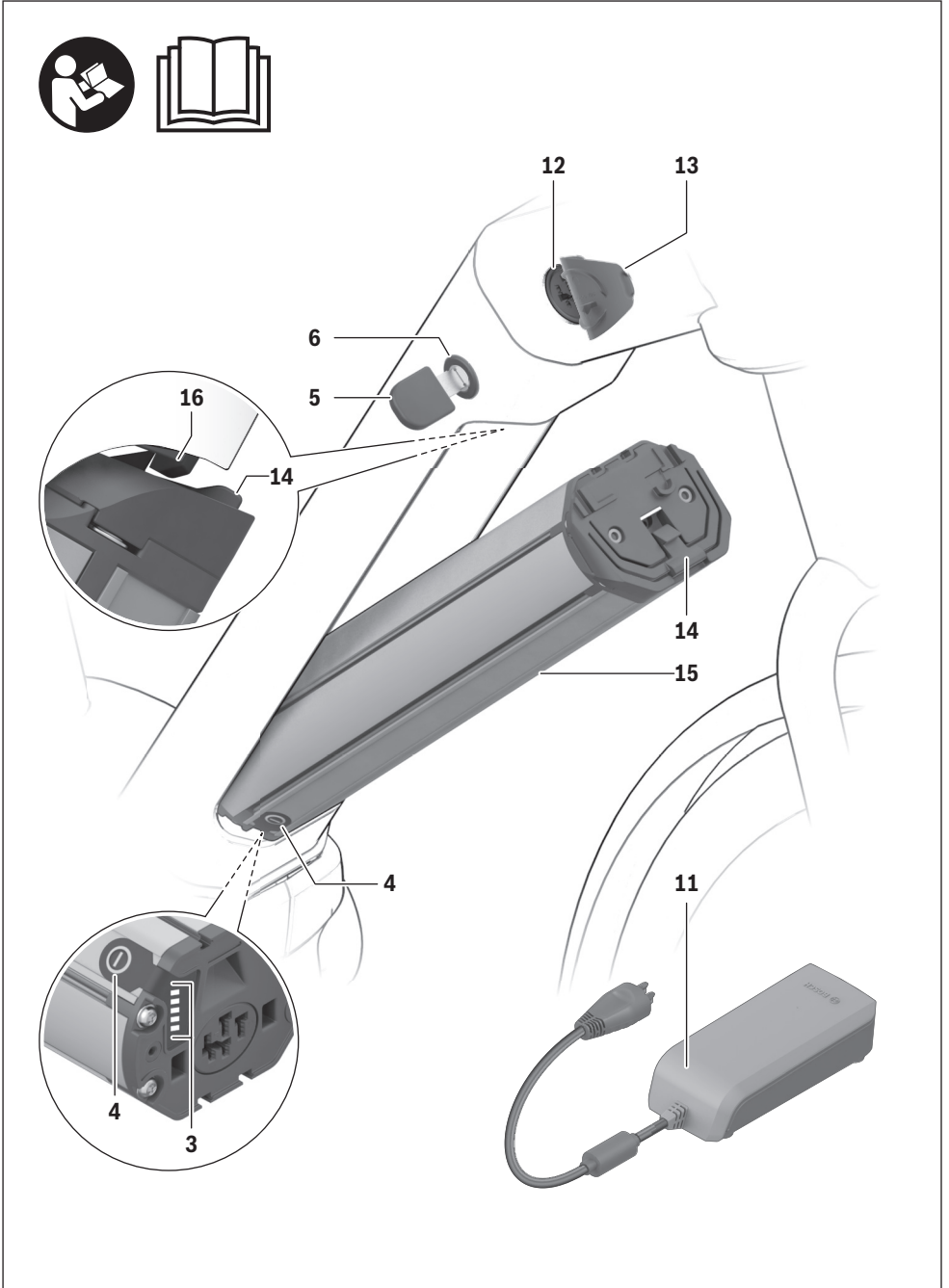

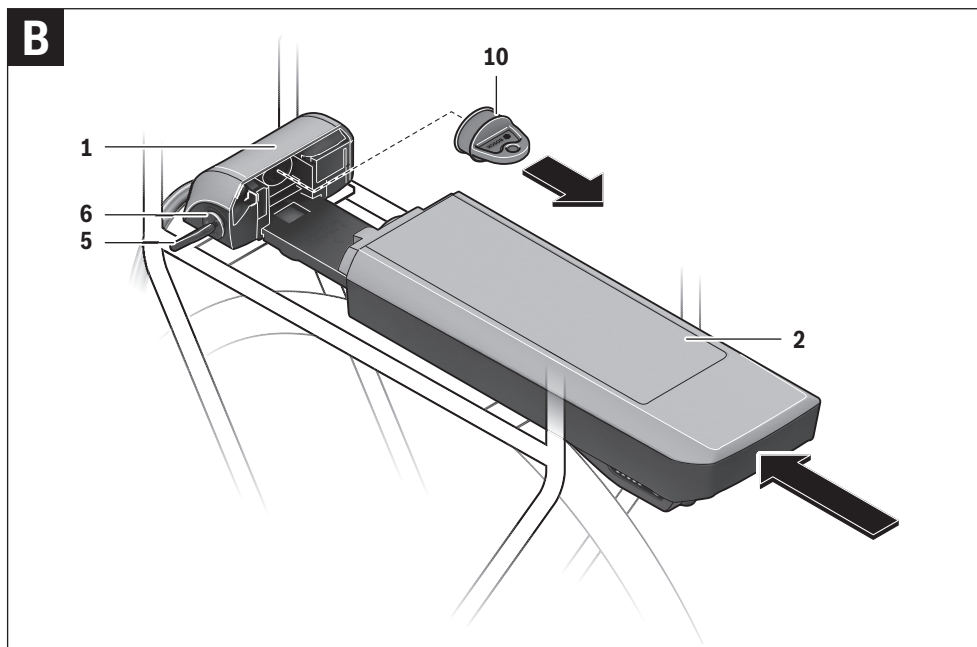
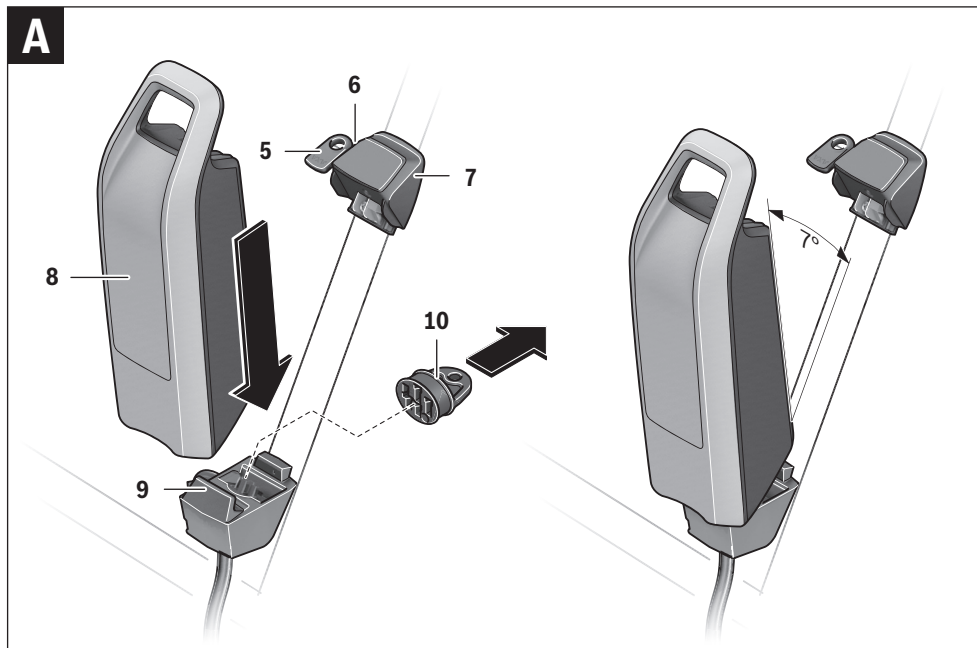

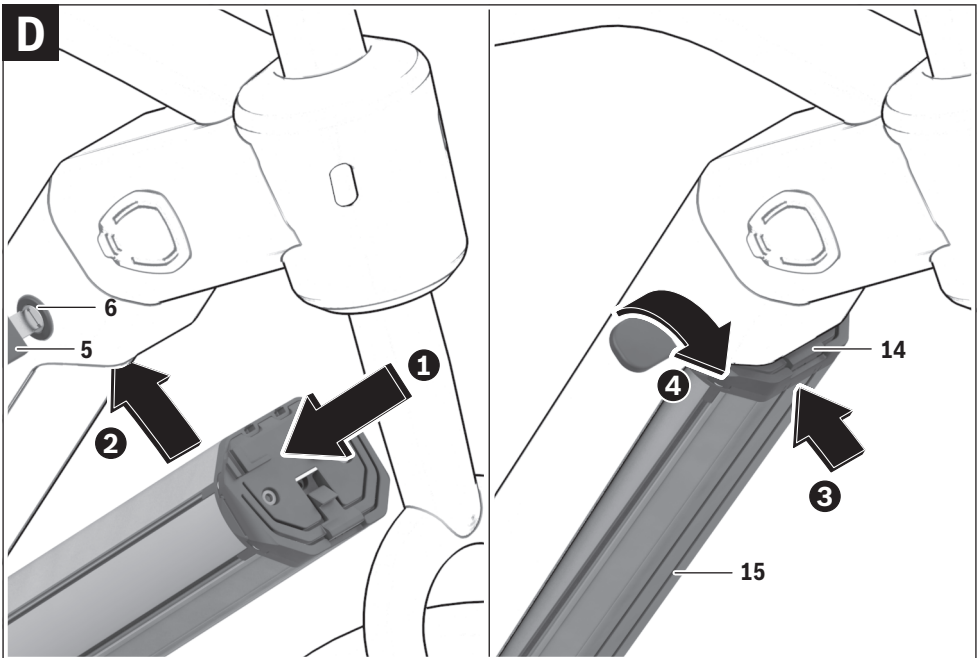
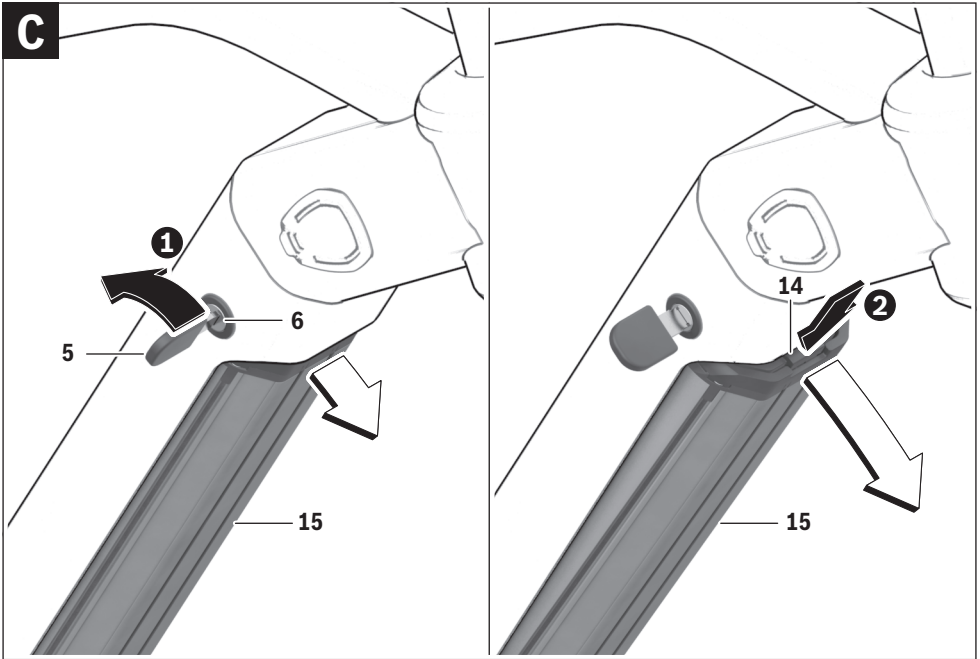

Safety Notes



Read all safety warnings and all instructions.

Failure to follow the warnings and instructions may result in electric shock, fire and/or serious

injury. The contents of lithium-ion battery cells are flammable under certain conditions. You must therefore ensure that you have read and understood the rules of conduct set out in these operating instructions.

Save all safety warnings and instructions for future reference.

The term “battery” is used in these instructions to mean all original Bosch eBike rechargeable battery packs.

- ▶ **Remove the battery pack from the eBike before beginning work (e.g. inspection, repair, assembly, maintenance, work on the chain, etc.) on the eBike, transporting it by car or plane, or storing it.** Unintentional activation of the eBike system poses a risk of injury.
- ▶ **Do not open the battery pack.** Danger of short-circuiting. Opening the battery pack voids any and all warranty claims.



Protect the battery against heat (e.g. prolonged sun exposure) and fire and from being submerged in water. Do not store or operate the battery near hot or flammable objects.

There is a risk of explosion.

- ▶ **Keep the battery pack not being used away from paper clips, coins, keys, nails, screws or other small metal objects, that can make a connection from one terminal to another.** Shorting the battery-pack terminals together may cause burns or a fire. For short-circuiting damage caused in this manner, any and all warranty claims through Bosch shall be invalid.
- ▶ **Avoid mechanical loads and exposure to high temperatures.** These can damage the battery cells and cause the flammable contents to leak out.
- ▶ **Do not place the charger or battery pack near to flammable materials. Charge battery packs only when dry and in a fireproof area.** There is a risk of fire due to the heat generated during charging.
- ▶ **The eBike battery must not be left unattended while charging.**

- ▶ **Under abusive conditions, liquid may be ejected from the battery pack. Avoid contact. If contact accidentally occurs, flush with water. If liquid contacts eyes, additionally seek medical help.** Liquid ejected from the battery pack may cause skin irritations or burns.
- ▶ **Battery packs must not be subjected to mechanical impacts.** There is a risk that the battery pack will be damaged causing vapours to escape. The vapours can irritate the respiratory system. Provide for fresh air and seek medical attention in case of complaints.
- ▶ **The battery may give off fumes if it becomes damaged or is used incorrectly. Provide a fresh air supply and seek medical advice in the event of pain or discomfort.** These fumes may irritate the respiratory tract.
- ▶ **Charge the battery pack only with original Bosch battery chargers.** When using non-original Bosch chargers, the danger of fire cannot be excluded.
- ▶ **Use the battery pack only together with eBikes that have an original Bosch eBike drive system.** This is the only way to protect the battery pack against dangerous overload.
- ▶ **Use only original Bosch battery packs approved for your eBike by the manufacturer.** Using other battery packs can lead to injuries and pose a fire hazard. When using other battery packs, Bosch shall not assume any liability and warranty.
- ▶ **Do not use the rack-type battery pack as a handle.** Lifting the eBike up by the battery pack can cause damage to the battery pack.
- ▶ **Read and observe the safety warnings and instructions in all operating instructions of the eBike system and in the operating instructions of your eBike.**
- ▶ **Keep the battery pack out of reach of children.**
- ▶ The safety of both our products and customers is important to us. Our PowerPacks are lithium-ion batteries which have been developed and manufactured in accordance with the latest technology. We comply with or exceed the requirements of all relevant safety standards. When charged, these lithium-ion batteries contain a high level of energy. In the case of a fault (which may not be detectable from the outside), lithium-ion batteries can, in very rare cases and under unfavourable conditions, catch fire.

Product Description and Specifications

Product Features

The numbering of the product features refers to the illustrations on the graphics pages.

All representations of bike components, with exception of the battery packs and their holders, are schematic and can deviate from your eBike.

In addition to the functions shown here, changes to software relating to troubleshooting and functional enhancements may be introduced at any time.

- 1 Holder of the rack-type battery pack
- 2 Rack-type battery pack
- 3 Operation and charge-control indicator

- 4 On/Off button
- 5 Key of the battery pack lock
- 6 Battery-pack lock
- 7 Upper holder of the standard battery pack
- 8 Standard battery pack
- 9 Bottom holder of the standard battery pack
- 10 Cover lid (Supplied only on eBikes with 2 battery packs)
- 11 Battery charger
- 12 Socket for charge connector
- 13 Charge socket cover
- 14 PowerTube safety restraint
- 15 PowerTube frame battery
- 16 PowerTube safety hook

Technical Data

Lithium-ion battery pack	PowerPack 300	PowerPack 400	PowerPack 500	PowerTube
Article number	0 275 007 547 ^{S)} * 0 275 007 548 ^{S)} * 0 275 007 549 ^{S)} * 0 275 007 513 ^{R)} *	0 275 007 510 ^{S)} 0 275 007 512 ^{S)} 0 275 007 514 ^{R)} 0 275 007 522 ^{R)} 0 275 007 525 ^{R)} 0 275 007 526 ^{R)}	0 275 007 529 ^{S)} 0 275 007 530 ^{S)} 0 275 007 531 ^{R)} 0 275 007 532 ^{R)}	0 275 007 539 0 275 007 540
Rated voltage	V= 36	36	36	36
Rated capacity	Ah 8.2	11	13.4	13.4
Energy	Wh 300	400	500	500
Operating temperature	°C -10 ... +40	-10 ... +40	-10 ... +40	-10 ... +40
Storage temperature	°C -10 ... +60	-10 ... +60	-10 ... +60	-10 ... +60
Allowable charging temperature range	°C 0 ... +40	0 ... +40	0 ... +40	0 ... +40
Weight, approx.	kg 2.5/2.6	2.5/2.6	2.6/2.7	2.8
Degree of protection	IP 54 (dust and splash water protected)	IP 54 (dust and splash water protected)	IP 54 (dust and splash water protected)	IP 54 (dust and splash water protected)

S) Standard battery pack

R) Rack-type battery pack

* Cannot be used in combination with other batteries in systems with two batteries

Assembly

- **Place down the battery pack only on clean surfaces.** In particular, avoid soiling the charge socket and the contacts, e. g. by means of sand or soil.

Checking the Battery Pack Before Using for the First Time

Check the battery pack before charging it or using it with your eBike for the first time.

For this, press the On/Off button **4** to switch on the battery pack. When no LED of the charge-control indicator **3** lights up, the battery pack may be damaged.

When at least one, but not all LEDs of the charge-control indicator **3** is lit, then fully charge the battery pack before using for the first time.

- **Do not attempt to charge or use a damaged battery pack.** Please refer to an authorised Bosch eBike dealer.

Charging the Battery Pack

► **Use only the Bosch charger provided with your eBike or an identical original Bosch charger.** Only this charger is matched to the lithium-ion battery pack used in your eBike.

Note: The battery pack is supplied partially charged. To ensure full battery pack capacity, completely charge the battery pack in the charger before using for the first time.

For charging the battery pack, read and observe the operating instructions of the charger.

The battery can be charged at any level of charge. Interrupting the charging process does not damage the battery pack.

The battery pack is equipped with a temperature control indicator, which enables charging only within a temperature range between 0 °C and 40 °C.



When the battery pack is not within the charging-temperature range, three LEDs of the charge-control indicator **3** flash. Disconnect the battery pack from the charger until its temperature has adjusted.

Do not connect the battery pack to the charger until it has reached the allowable charging temperature.

Charge-control Indicator

When the battery pack is switched on, the five green LEDs of the charge-control indicator **3** indicate the charge condition of the battery pack.

In this, each LED indicates approx. 20 % capacity. When the battery pack is completely charged, all five LEDs light up.

The charge level of the switched on battery pack is also shown on the display of the on-board computer. When doing so, read and observe the operating instructions of the drive unit and on-board computer.

If the capacity of the battery pack is below 5 %, all LEDs of the charge-control indicator **3** on the battery pack go out. However there is another display function of the on-board computer.

After charging, disconnect the battery from the charger and the charger from the network.

Using Two Battery Packs for One eBike (optional)

An eBike can also be equipped with two battery packs by the manufacturer. In this case, one of the charge sockets is not accessible or is sealed by the bicycle manufacturer with a sealing cap. Charge the battery packs only at the accessible charge socket.

► **Never open charge sockets that have been sealed by the manufacturer.** Charging at a previously sealed charge socket can lead to irreparable damage.

If you have an eBike that is designed for two battery packs and you want to use it with only battery pack, cover off the contacts of the unused socket using the cover lid **10** provided because otherwise the open contacts pose a risk of short-circuiting (see figures A and B).

Charging with Two Battery Packs Inserted

If two battery packs are mounted on one eBike, both battery packs can be charged using the unsealed connection. The charging process will charge both battery packs alternately, automatically switching between both battery packs numerous times. The charging times add up.

Both battery packs are also discharged alternately during operation.

If you take the battery packs out of the holders, you can charge each battery pack individually.

Charging with One Battery Pack Inserted

If only one battery pack is inserted, then you can charge only the battery pack that has the accessible charge socket on the bike. You can charge the battery pack with the sealed charge socket only when you take the battery pack out of the holder.

Inserting and removing the battery pack

► **Always switch off the battery pack and the eBike system when you insert the battery pack into the holder or when you take it out of the holder.**

Inserting and removing a standard battery (see figure A)

In order for the battery pack to be inserted, the key **5** must be inserted into the lock **6** and the lock must be unlocked.

To **insert the standard battery pack 8**, place it with the contacts on the lower holder **9** on the eBike (the battery pack can be inclined up to 7° to the frame). Tilt it into the upper holder **7** until it engages.

Check if the battery pack is tightly seated. Always lock the battery pack with lock **6**, as otherwise the lock can open and the battery pack could fall out of the holder.

After locking, always remove the key **5** from the lock **6**. This prevents the key from falling out and the battery pack from being removed from unauthorised persons when the eBike is parked.

To **remove the standard battery pack 8**, switch it off and unlock the lock with the key **5**. Tilt the battery pack out of the upper holder **7** and pull it out of the lower holder **9**.

Inserting and removing a rack battery (see figure B)

In order for the battery pack to be inserted, the key **5** must be inserted into the lock **6** and the lock must be unlocked.

To **insert the rack-type battery pack 2**, slide it with the contacts facing ahead until it engages in the holder **1** of the rear rack/carrier.

Check if the battery pack is tightly seated. Always lock the battery pack with lock **6**, as otherwise the lock can open and the battery pack could fall out of the holder.

After locking, always remove the key **5** from the lock **6**. This prevents the key from falling out and the battery pack from being removed from unauthorised persons when the eBike is parked.

To **remove the rack-type battery pack 2**, switch it off and unlock the lock with the key **5**. Pull the battery pack out of the holder **1**.

Removing a PowerTube frame battery (see figure C)

- ❶ To remove the PowerTube frame battery, **15** open the lock **6** using the key **5**. The battery will be unlocked and fall into the safety restraint **14**.
- ❷ Press on the safety restraint from above. The battery will be unlocked completely and fall into your hand. Pull the battery out of the frame.

Note: As a result of **varying** designs, the frame battery may have to be inserted and removed using a different method. In this case, consult the bicycle documentation provided by your bicycle manufacturer.

Inserting a PowerTube frame battery (see figure D)

In order for the battery pack to be inserted, the key **5** must be inserted into the lock **6** and the lock must be unlocked.

- ❶ To insert the PowerTube frame battery, **15** place it so that its contacts are in the lower bracket of the frame.
- ❷ Push the battery upwards until it is held by the safety restraint **14**.
- ❸ Press the battery upwards until you hear it engage. Check that the battery is secure.
- ❹ Always secure the battery by closing the lock **6** – otherwise, the lock may open and the battery may fall out of the bracket.

After locking, always remove the key **5** from the lock **6**. This prevents the key from falling out and the battery pack from being removed from unauthorised persons when the eBike is parked.

Operation

Initial Operation

- ▶ **Use only original Bosch battery packs approved for your eBike by the manufacturer.** Using other battery packs can lead to injuries and pose a fire hazard. When using other battery packs, Bosch shall not assume any liability and warranty.

Switching On and Off

Switching on the battery pack is one of the ways of switching on the eBike system. When doing so, read and observe the operating instructions of the drive unit and on-board computer.

Before switching on the battery pack or the eBike system, check that the lock **6** is locked.

To **switch on** the battery pack, press the On/Off button **4**. The LEDs of indicator **3** light up and at the same time indicate the charge condition.

Note: If the capacity of the battery pack is below 5 %, no LED on the charge-control indicator **3** lights up. It is only visible on the on-board computer, if the eBike system is switched on.

To **switch off** the battery pack, press the On/Off button **4** again. The LEDs of indicator **3** go out. This also switches off the eBike system.

If no power is drawn from the eBike drive for about 10 minutes (e.g. because the eBike is not moving) and no button is pressed on the on-board computer or the operating unit of the eBike, the eBike system and therefore also the battery pack will shut down automatically to save energy.

The battery pack is protected against deep discharging, overcharging, overheating and short-circuiting through the “Electronic Cell Protection (ECP)”. In case of hazardous situations, a protective circuit automatically switches off the battery pack.



When a defect of the battery pack is detected, two LEDs of the charge-control indicator **3** flash. In this case, please refer to an authorised Bosch eBike dealer.

Notes for Optimum Handling of the Battery Pack

The battery-pack life can be prolonged when being properly maintained and especially when being operated and stored at the right temperatures.

With increasing age, however, the battery-pack capacity will diminish, even when properly maintained.

A significantly reduced operating period after charging indicates that the battery pack is worn out and must be replaced. You can replace the battery pack yourself.

Recharging the Battery Pack prior to and during Storage

When not using the battery pack for a longer period, charge it to approx. 60 % (3 to 4 LEDs lit on the charge-control indicator **3**).

Check the charge condition after 6 months. When only one LED of the charge-control indicator **3** lights up, recharge the battery pack again approx. 60 %.

Note: When the battery pack is stored discharged (empty) for longer periods, it can become damaged despite the low self-discharging feature and the battery-pack capacity may be strongly reduced.

It is not recommended to have the battery pack connected permanently to the charger.

Storage Conditions

Store the battery pack in a dry, well-ventilated location. Protect the battery pack against moisture and water. Under unfavourable weather conditions, it is recommended e.g. to remove the battery pack from the eBike and store it in an enclosed location until being used again.

Store the eBike batteries in the following locations::

- in a room with a smoke alarm
- away from combustible or easily flammable objects
- away from heat sources

Store the batteries at temperatures between 0 °C and 20 °C. Never store them at temperatures below – 10 °C or above +60 °C. To ensure that the lifetime is as long as possible, storage at approx. 20 °C (room temperature) is recommended.

Take care that the maximal storage temperature is not exceeded. As an example, do not leave the battery pack in a vehicle in summer and store it out of direct sunlight.

It is recommended to not store the battery pack on the bike.

Maintenance and Service

Maintenance and Cleaning

- ▶ **The battery must not be submerged in water or cleaned using a jet of water.**

Keep the battery clean. Clean it carefully with a soft, damp cloth.

Clean and lightly grease the connector pins occasionally.

When the battery pack is no longer operative, please refer to an authorised Bosch eBike dealer.

After-sales Service and Application Service

In case of questions concerning the battery packs, please refer to an authorised bicycle dealer.

- ▶ **Note down the manufacturer and the number of the key 5.** In case of loss of the keys, please refer to an authorised bicycle dealer. Please provide the name of the manufacturer and the number of the key.

For contact data of authorised Bosch eBike dealers, please refer to www.bosch-ebike.com

Transport

- ▶ **If you carry your eBike outside of your car, e.g. on a luggage rack, remove the eBike battery pack in order to avoid damaging it.**

The battery packs are subject to the Dangerous Goods Legislation requirements. Private users can transport undamaged battery packs by road without further requirements.

When being transported by commercial users or third parties (e.g. air transport or forwarding agency), special requirements on packaging and labelling must be observed (e.g. ADR regulations). If necessary, an expert for hazardous materials can be consulted when preparing the item for shipping.

Dispatch battery packs only when the housing is undamaged. Tape or mask off open contacts and pack up the battery pack in such a manner that it cannot move around in the packaging. Inform your parcel service that the package contains dangerous goods. Please also observe the possibility of more detailed national regulations.

In case of questions concerning transport of the battery packs, please refer to an authorised Bosch eBike dealer. The Bosch eBike dealers can also provide suitable transport packaging.

Disposal



Battery packs, accessories and packaging should be sorted for environmental-friendly recycling.

Do not dispose of the battery packs into household waste!

Tape or mask off the contact surfaces of the battery pack's terminals with adhesive tape before disposing of battery packs.

Do not touch heavily damaged eBike batteries with your bare hands. Electrolyte may escape and cause skin irritation. Store the battery in a safe location outdoors. Cover the pins if necessary and inform your dealer. They will help you to dispose of it properly.

Only for EC countries:



According to the European Guideline 2012/19/EU, electrical devices/tools that are no longer usable, and according to the European Guideline 2006/66/EC, defective or used battery packs/batteries, must be collected separately and disposed of in an environmental-ly correct manner.

Please return battery packs that are no longer usable to an authorised bicycle dealer.



Li-ion:



Please observe the instructions in section "Transport", page English – 5.

Subject to change without notice.

en EU Declaration of Conformity
PowerPack
PowerTube

Article number

We declare under our sole responsibility that the stated products comply with all applicable provisions of the directives and regulations listed below and are in conformity with the following standards.
 Technical file at: *

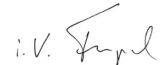
PowerPack PowerTube	0 275 007 547...548	2014/30/EU	EN 55014-1:2006 + A1:2009 + A2:2011
	0 275 007 510	2011/65/EU	EN 55014-2:1997 + A1:2001 + A2:2008
	0 275 007 512...514		EN 61000-3-2:2014
	0 275 007 522		EN 61000-3-3:2013
	0 275 007 529...532		UN 38.3 Rev. 5
	0 275 007 539...540		EN 15194:2009 + A1:2011
		 BOSCH	* Bosch eBike Systems 72703 Reutlingen GERMANY
		Claus Fleischer Senior Vice President	Gunter Flinspach Vice President
		 	i. V. Flinspach
		Bosch eBike Systems, 72703 Reutlingen, GERMANY Reutlingen, 28.03.2017	

Active Line

Robert Bosch GmbH

Bosch eBike Systems
72703 Reutlingen
GERMANY

www.bosch-ebike.com

0 275 007 XPX (2017.05) T / 71 WEU

Active Line

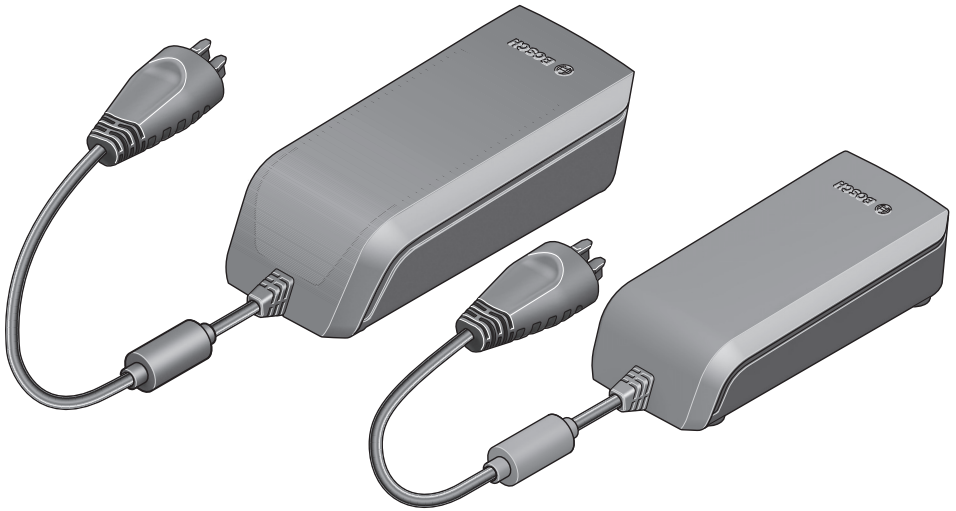

Charger

BCS220: 0 275 007 907

BCS230: 0 275 007 915

BCS212: 0 275 007 923



BOSCH

en Original instructions



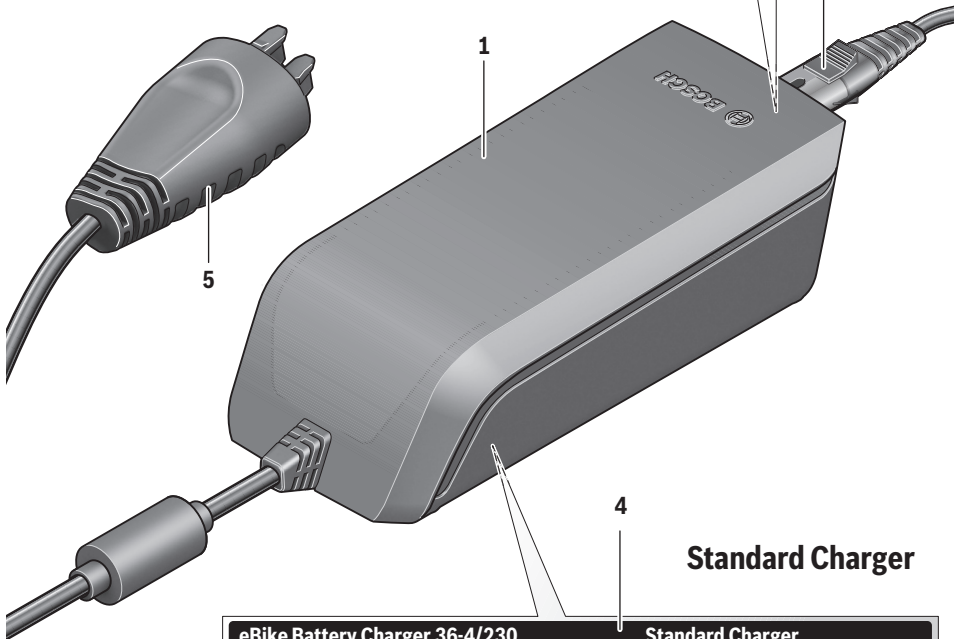
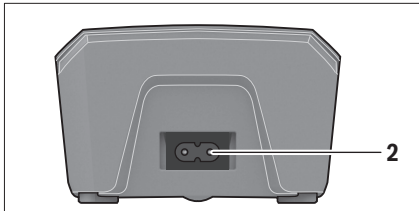

Standard Charger

<p>eBike Battery Charger 36-4/230 0 275 007 907 Input: 230V ~ 50Hz 1.5A Output: 36V === 4A Made in [] Robert Bosch GmbH, Reutlingen</p>	<p>Standard Charger Li-Ion Use ONLY with BOSCH Li-Ion batteries</p>
<p>eBike Battery Charger 36-4/100-230 0 275 007 923 Input: 100V - 230V ~ 50-60Hz 2.2A Output: 36V === 4A Made in PRC Robert Bosch GmbH, Reutlingen</p>	<p>警告</p> <ul style="list-style-type: none"> • 使用前には、必ず取り扱い説明書をお読みください。 • 指定のボッシュ リチウムイオンバッテリー以外の充電に使用しないでください。 • 屋内専用です。雨に濡らしたり、湿気の多い場所で使用しないでください。 • 燃えやすい物の側で、使用しないでください。 • 分解や、改造をしないでください。 • 使用前にはコードの損傷を確認し、コードが損傷した物は使用しないでください。

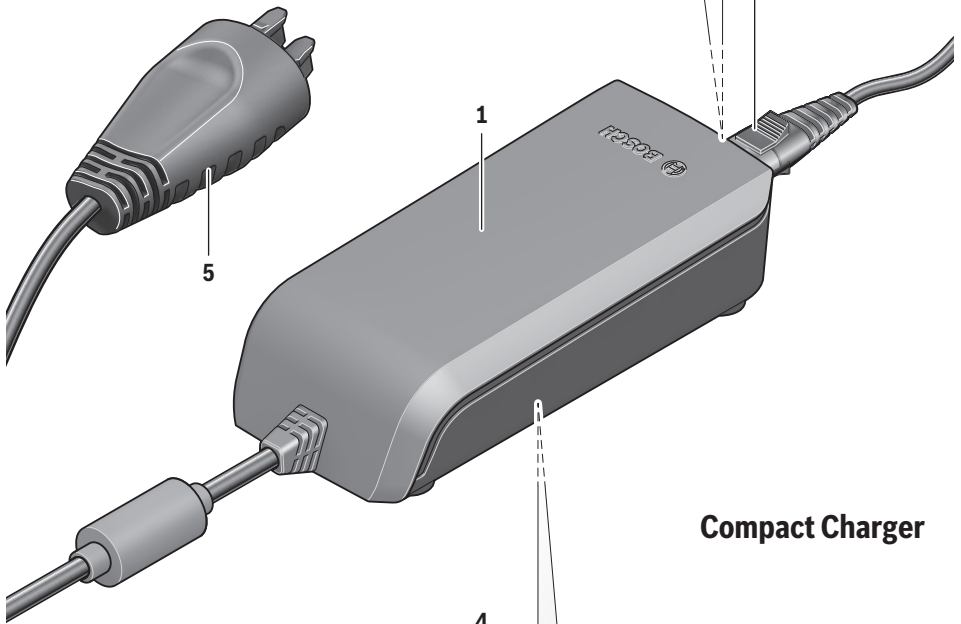
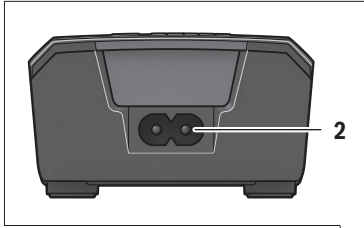

Compact Charger

<p>eBike Battery Charger 36-2/100-240 0 275 007 915 Input: 100-240V ~ 50/60 Hz 1.6A Output: 36V --- 2A Made in Robert Bosch GmbH, Reutlingen</p>	<p>Active/Performance Line Li-Ion USE ONLY with BOSCH Li-Ion batteries</p>

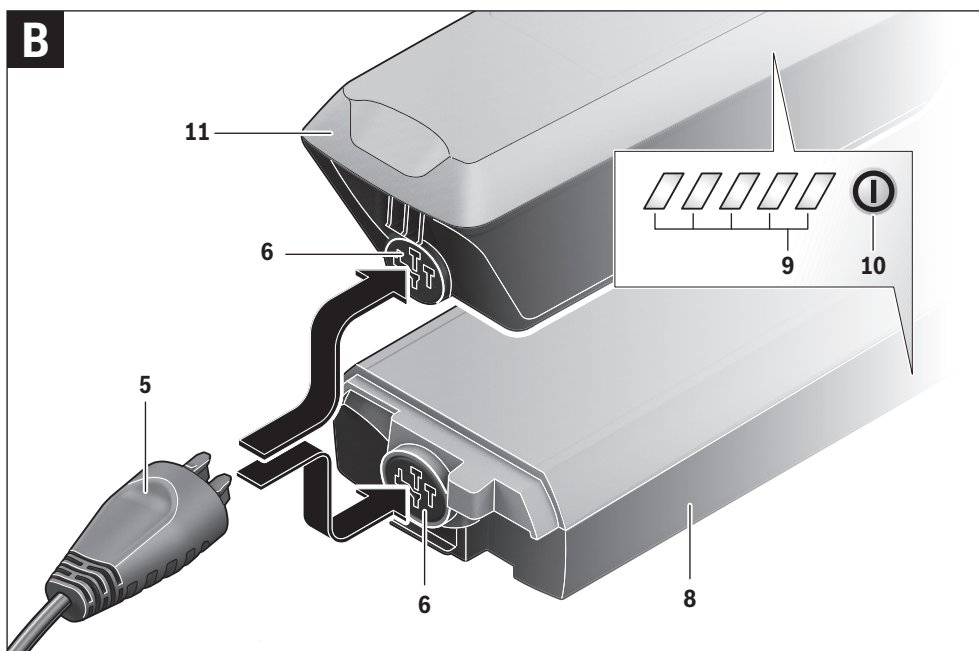
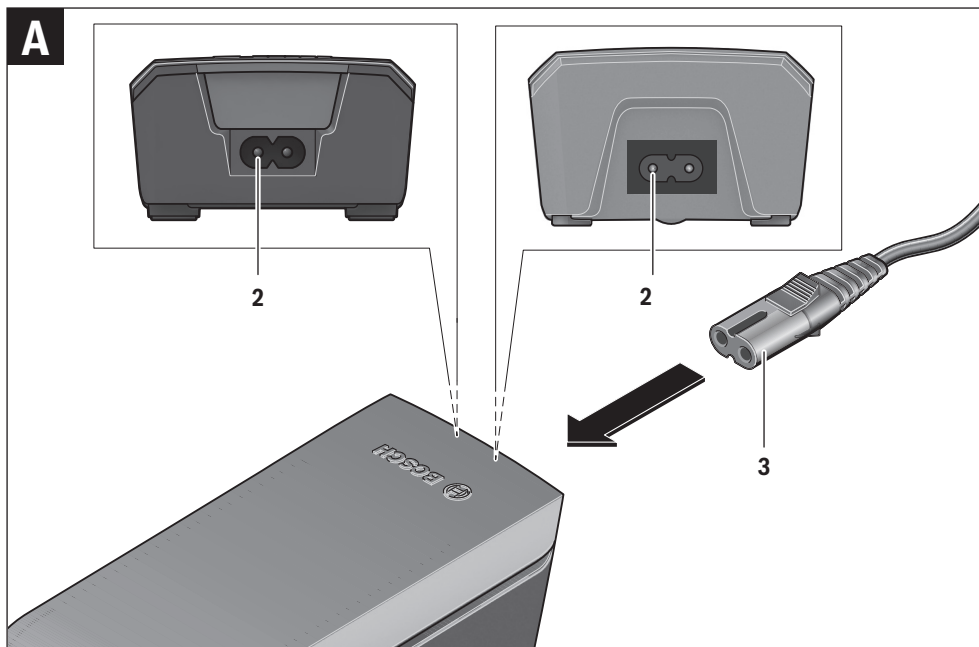

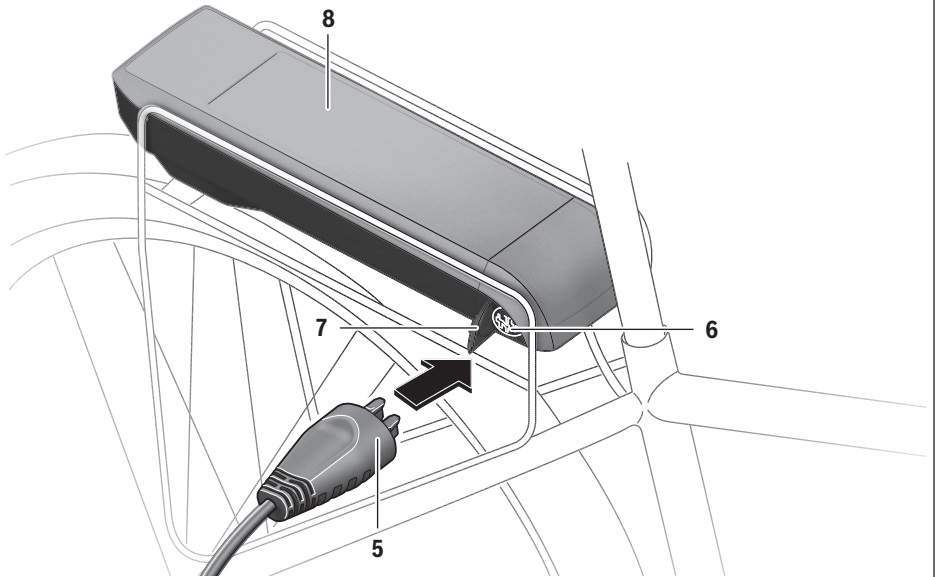
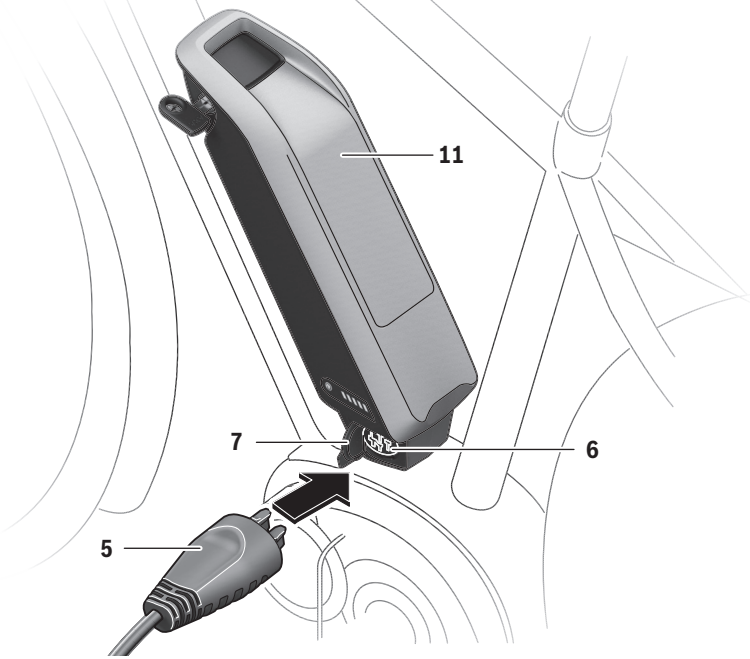
C

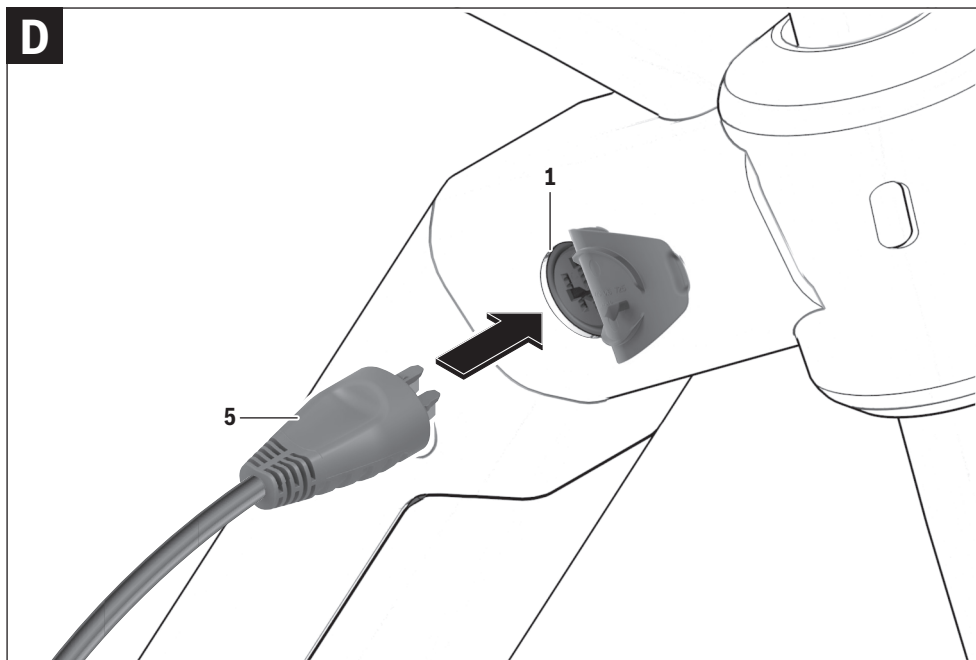

Safety Notes



Read all safety warnings and all instructions. Failure to follow the warnings and instructions may result in electric shock, fire and/or serious injury.

Save all safety warnings and instructions for future reference.

The term "battery" is used in these instructions to mean all original Bosch eBike rechargeable battery packs.



Keep the charger away from rain or moisture. The penetration of water into a battery charger increases the risk of an electric shock.

- ▶ **Only charge eBike-approved Bosch lithium-ion battery packs. The battery-pack voltage must match the battery-pack charging voltage of the charger.** Otherwise there is danger of fire and explosion.
- ▶ **Keep the battery charger clean.** Contamination can lead to danger of an electric shock.
- ▶ **Always check the charger, cable and plug before use. Do not use the charger if you discover any damage. Do not open the charger.** Damaged chargers, cables and plugs increase the risk of electric shock.
- ▶ **Do not operate the battery charger on easily inflammable surfaces (e. g., paper, textiles, etc.) or surroundings.** The heating of the battery charger during the charging process can pose a fire hazard.
- ▶ **Use caution when touching the charger during the charging procedure. Wear protective gloves.** Especially in high ambient temperatures, the charger can heat up considerably.
- ▶ **The battery may give off fumes if it becomes damaged or is used incorrectly. Provide a fresh air supply and seek medical advice in the event of pain or discomfort.** These fumes may irritate the respiratory tract.
- ▶ **Do not place the charger or battery pack near to flammable materials. Charge battery packs only when dry and in a fireproof area.** There is a risk of fire due to the heat generated during charging.
- ▶ **The eBike battery must not be left unattended while charging.**

- ▶ **Supervise children during use, cleaning and maintenance.** This will ensure that children do not play with the charger.
- ▶ **Children or persons that owing to their physical, sensory or mental limitations or to their lack of experience or knowledge, are not capable of securely operating the charger, may only use this charger under supervision or after having been instructed by a responsible person.** Otherwise, there is danger of operating errors and injuries.
- ▶ **Read and observe the safety warnings and instructions in all operating instructions of the eBike system and in the operating instructions of your eBike.**
- ▶ A sticker in English is adhered to the bottom of the charger (marked **4** in the diagram on the graphics page). This says: Use ONLY with BOSCH lithium-ion batteries.

Product Description and Specifications

In addition to the functions shown here, changes to software relating to troubleshooting and functional enhancements may be introduced at any time.

Product Features

The numbering of the components shown refers to the illustrations on the graphic pages at the beginning of the manual. Individual illustrations in these operating instructions may differ slightly from the actual circumstances depending on the equipment of your eBike.

- 1 Battery charger
- 2 Charger socket
- 3 Plug-in connector
- 4 Safety warnings, charger
- 5 Charge connector
- 6 Socket for charge connector
- 7 Charge socket cover
- 8 Rack-type battery pack
- 9 Operating/state of charge indicator
- 10 Battery on/off button
- 11 Standard battery pack

Technical Data

Battery Charger		Standard Charger (36 – 4/230)	Standard Charger (36 – 4/100-230)	Compact Charger (36 – 2/100-240)
Article number		0 275 007 907	0 275 007 923	0 275 007 915
Rated voltage	V~	207 ... 264	90 ... 264	90 ... 264
Frequency	Hz	47 ... 63	47 ... 63	47 ... 63
Output voltage	V=	36	36	36
Charging current (max.)	A	4	4	2
Charging time				
– PowerPack 300, approx.	h	2.5	2.5	5
– PowerPack 400, approx.	h	3.5	3.5	6.5
– PowerPack 500, approx.	h	4.5	4.5	7.5
Operating temperature	°C	– 5 ... + 40	– 5 ... + 40	– 5 ... + 40
Storage temperature	°C	– 10 ... + 50	– 10 ... + 50	– 10 ... + 50
Weight, approx.	kg	0.8	0.8	0.6
Degree of protection		IP 40	IP 40	IP 40

The values given are valid for a nominal voltage [U] of 230 V. For different voltages and models for specific countries, these values can vary.

Operation

Initial Operation

Connecting the charger to the mains (see figure A)

► **Observe the mains voltage!** The voltage of the power supply must correspond with the data given on the nameplate of the battery charger. Battery chargers marked with 230 V can also be operated with 220 V.

Plug the charger plug **3** of the power cord into the charger socket **2** of the charger.

Connect the mains cable (country-specific) to the mains supply.

Charging the removed battery (see figure B)

Switch the battery pack off and remove it from the holder of the eBike. For this, read and observe the operating instructions of the battery pack.

► **Place down the battery pack only on clean surfaces.** In particular, avoid soiling the charge socket and the contacts, e. g. by means of sand or soil.

Insert the charger plug **5** of the battery charger into the socket **6** on the battery pack.

Charging the battery on the Bike (see figures C and D)

Switch the battery off. Clean the cover of the charge socket **7**. Prevent especially the charge socket and the contacts from getting dirty, e. g. by sand or soil. Lift the cover of the charge socket **7** and plug the charge connector **5** into the charge socket **6**.

► **Charge the battery only in accordance with all safety instructions.** If this is not possible, remove the battery from the holder and charge it in a more suitable location. When doing so, read and observe the operating instructions of the battery.

Charging with Two Battery Packs Inserted

If two battery packs are mounted on one eBike, both battery packs can be charged using the unsealed connection. The charging process will charge both battery packs alternately, automatically switching between both battery packs numerous times. The charging times add up.

Both battery packs are also discharged alternately during operation.

If you take the battery packs out of the holders, you can charge each battery pack individually.

Charging Procedure

The charging procedure begins as soon as the charger is connected to the battery or the charge socket on the bike and the main power supply.

Note: Charging is only possible if the temperature of the eBike battery is within the permitted charging temperature range.

Note: The drive unit is deactivated during the charging procedure.

The battery can be charged with and without the on-board computer. When charging without the on-board computer, the charging procedure can be observed on the battery charge-control indicator.

When the on-board computer is connected, a corresponding message is shown on the display.

The charging state is displayed by the battery charge-control indicator **9** on the battery and by the bars on the on-board computer.

During the charging procedure, the LEDs of charge-control indicator **9** on the battery pack light up. Each continuously lit LED is equivalent to a charge capacity of approx. 20 %. The flashing LED indicates the charging of the next 20 %.

Once the eBike battery is fully charged, the LEDs extinguish immediately and the on-board computer is switched off. The charging procedure is terminated. The charging state can be displayed for 3 seconds by pressing the on/off button **10** on the eBike battery.



Disconnect the charger from the main power supply and the battery pack from the charger.

When disconnecting the battery pack from the charger, the battery pack is automatically switched off.

Note: If you have charged on the bike, carefully close the charge socket **6** with the cover **7** after the charging procedure so that no dirt or water can get in.

If the charger is not disconnected from the battery after charging, after a few hours the charger will switch itself back on, check the charging state of the battery and begin the charging procedure again if necessary.

Troubleshooting – Causes and Corrective Measures

Cause	Corrective Measure
 <p>Battery pack defective</p>	<p>Two LEDs of the battery pack flashing</p> <p>Refer to an authorised bicycle dealer.</p>
 <p>Battery pack too warm or too cold</p>	<p>Three LEDs of the battery pack flashing</p> <p>Disconnect the battery from the charger until the charging temperature range has been reached.</p> <p>Do not connect the battery pack to the charger until it has reached the allowable charging temperature.</p>
 <p>The charger is not charging.</p>	<p>No LEDs flashing (one or more LEDs will remain permanently lit depending of the state of charge of the eBike battery).</p> <p>Refer to an authorised bicycle dealer.</p>

Cause	Corrective Measure
No charging procedure possible (no indication on battery pack)	
Plug not inserted correctly	Check all plug connections.
Contacts of battery pack soiled	Carefully clean the contacts of the battery pack.
Socket outlet, cable or charger defective	Check mains voltage, have charger checked through bicycle dealer
Battery pack defective	Refer to an authorised bicycle dealer.

Maintenance and Service

Maintenance and Cleaning

If the charger should fail, please refer to an authorised bicycle dealer.

After-sales Service and Application Service

In case of questions concerning the charger, please refer to an authorised bicycle dealer.

For contact data of authorised Bosch eBike dealers, please refer to www.bosch-ebike.com

Disposal

Battery chargers, accessories and packaging should be sorted for environmental-friendly recycling.

Do not dispose of battery chargers into household waste!

Only for EC countries:









According to the European Directive 2012/19/EU on waste electrical and electronic equipment and its transposition into national law, chargers that are no longer usable must be collected separately and sorted for environmental-friendly recycling.

Subject to change without notice.

en EU Declaration of Conformity
Charger Article number

We declare under our sole responsibility that the stated products comply with all applicable provisions of the directives and regulations listed below and are in conformity with the following standards.
 Technical file at: *

Standard Charger	0 275 007 907	2014/35/EU	EN 60335-1:2012
		2014/30/EU	EN 60335-2-29:2004+A2:2010
		2009/125/EC	EN 61000-3-2:2014
		2011/65/EU	EN 61000-3-3:2013
			EN 55014-1:2006+A1:2009+A2:2011
			EN 55014-2:1997+A1:2001+A2:2008
		 BOSCH	* Robert Bosch Power Tools GmbH (PT/ECS) 70538 Stuttgart GERMANY
		Claus Fleischer Senior Vice President	Gunter Flinspach Vice President
		 	i. V. Flinspach
		Bosch eBike Systems, 72703 Reutlingen, GERMANY Reutlingen, 01.04.2016	
Compact Charger	0 275 007 915	2014/35/EU	EN 60335-1:2012
		2014/30/EU	EN 60335-2-29:2004 + A2:2010
		2009/125/EC	EN 61000-3-2:2014
		2011/65/EU	EN 61000-3-3:2013
			EN 55014-1:2006+A1:2009+A2:2011
			EN 55014-1:1997+A1:2001+A2:2008
		 BOSCH	* Robert Bosch Power Tools GmbH (PT/ECS) 70538 Stuttgart GERMANY
		Claus Fleischer Senior Vice President	Gunter Flinspach Vice President
		 	i. V. Flinspach
		Bosch eBike Systems, 72703 Reutlingen, GERMANY Reutlingen, 01.04.2016	

Active Line

Robert Bosch GmbH

Bosch eBike Systems
72703 Reutlingen
GERMANY

www.bosch-ebike.com

0 275 007 XCX (2017.04) T / 51 WEU

CONTACT

Limited warranty

Your bicycle is covered by a Lifetime Limited Warranty.

Please visit our web site for details.

Contact

Address and telephone number:

Trek Australia

Customer Service

PO Box 1747

Fyshwick, ACT 2609

Telephone number: +61 2 6173 2400

Internet: www.trekbikes.com

For Service and Warranty, please contact your local dealer.

Please refer to the Trek website (Menu/Support) for the latest revision of this manual. New features, as described in the latest manual, may not be applicable on your RIDE+ bicycle.

P/N 562522 Rev A, June 2017

© 2017 Trek Bicycle Corporation. All rights reserved.

