



NH₃ Evaporator

Ammonia Applications 12-108 Tons

MANIP

> > USED FOR MEDIUM TO LARGE INDUSTRIAL AMMONIA APPLICATIONS –
MANUFACTURED WITH STAINLESS STEEL TUBES.

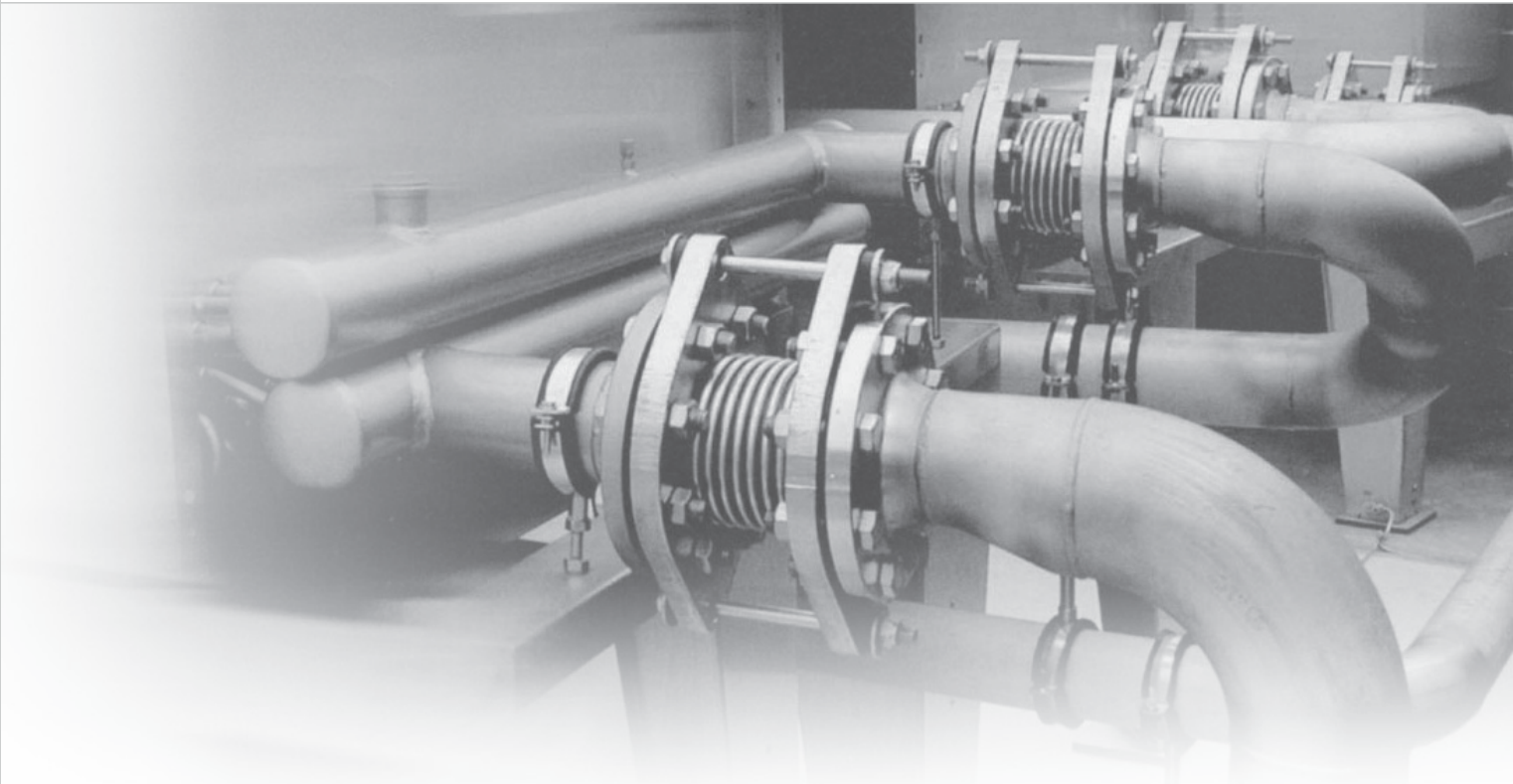

The Global Leader

In Heat Exchange Technology

With seven decades of experience and commitment to total client satisfaction, Guntner has earned a reputation as the global leader in heat exchange technology. Supported by the best R&D engineers in the business, cutting-edge technology, and eight manufacturing facilities around the world, Guntner continues to break new ground in the demanding market of finned heat exchangers for industrial refrigeration, HVAC, and process cooling applications. Our high standards and dedication to society and the environment around us have earned us the respect of the industry, and the privilege of long-term relationships with our customers around the world.



...keep(s) your quality

The Guntner Product Calculator



With the Guntner product calculator “MPC,” we are able to offer you more than just an overview of prices or the complete product range. This thermodynamic selection program enables you to calculate your own tailored selections based on precise and actual thermodynamics rather than factors or multipliers. A team of experts stand by to guide you through the selection process.

The program can be updated via the internet ensuring that you always have the most exact and precise information for proper selection.

We recommend using Guntner’s Product Calculator for exact thermodynamic calculations. Varying conditions such as refrigerants, humidity levels and material combinations are all taken into account by the software to most accurately select products to fit your specific needs.

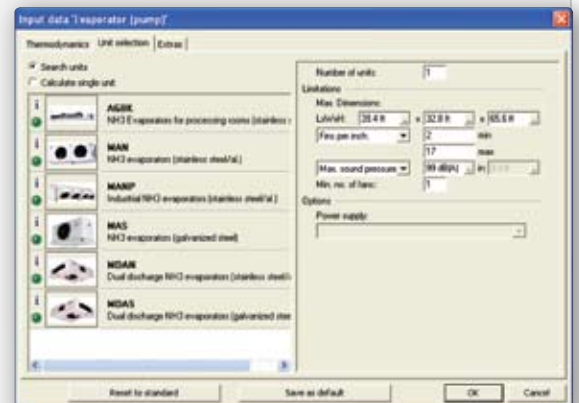
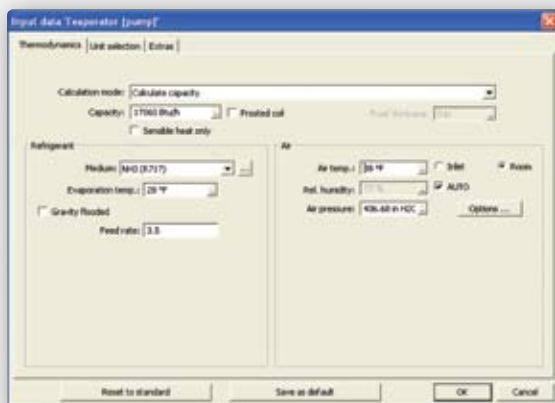

>> CALCULATIONS MADE EASY WITH OUR PRECISE MPC SOFTWARE

Standard Features of Construction



CASING: All models come with a choice of horizontal, 45 degree or 90 degree down air discharge.

All casings are made of corrosion resistant galvanized steel sheet casing, powder coated – color RAL 9003 (Signal White) and suitable for all stringent food industry applications.

Construction detail takes accessibility into account and does not allow for “tight spots.” All parts are easily accessible for service and cleaning purposes.

Fan orifices are optimized by manufacturer to ensure maximum efficiency, air throw and airflow. All fans are individually compartmentalized within complete tube sheets to allow for fan cycling, capacity control and reduction of operating costs.

Products have easily removable side and front panels that come complete with PVC handles for access to internal and electrical components. Inspection panels are positioned in 90 degree down blow ducts for motor access.

TRAY: All models have corrosion resistant, light-weight Aluminum (AlMg3) and are seawater resistant.

Trays are powder coated color - RAL 9003 (Signal White). All trays come in our unique “fold down” design and can be either folded down or completely removed, if required for cleaning purposes. The “sloped design” ensures maximum and efficient drainage during defrost cycle. Drain connections of the trays are sized and positioned to ensure complete drainage.



TUBE: Tubing is manufactured from the highest quality 304 stainless steel in accordance with ASME B31.5 5/8" (15mm) tubing.

Parallel, "in-line," 1.969" x 1.969" (50 x 50mm) allows the reduced air-side pressure to drop through the coil.

Tubes are mechanically expanded to ensure mechanical bonding coupled with the best heat transfer efficiency ratio from fin to tube.

Patented "floating coil" with support tubes does not permit the refrigerant carrying tubes to come into contact with the tube/end plates and eliminates the risk of tube failure at the end plates (Patent No. EP0209107B1).

All coils are pressure tested to 450 psig with dry air under water.

FINS: Aluminum fins with a corrugated pattern provide enhanced air turbulence, guaranteeing contact with all surface areas within the coil block.

100% drawn die formed finned collars are standard and result in accurate fin spacings of 6.3, 3.6, 2.5 and 2.1 FPI (4, 7, 10 and 12mm).

All fins are manufactured with a continuous fin sheet in order to reduce the risk of frost build-up, air-side pressure drops, dust, dirt and bacteria - simplifying any cleaning procedure.

COIL CIRCUITING: Each unit is specifically circuited to optimize coil performance and capacity (consult with selection software to obtain optimum circuiting for each application).

Horizontal headers are standard for smaller capacities. For larger capacities vertical headers are utilized.

All headers and connections are manufactured with 304 stainless steel in accordance with ASME B31.5. However, a carbon steel stub connection is provided for ease of installation.

FANS & MOTORS: The coolers are differentiated between high and low velocity for freezer or chiller applications.

Standard selections are available at 0", 1/4" and 1/2" of ESP.

Standard motors are completely enclosed with sealed bearings and low temperature grease, when required.

Motors range from 11/2 to 71/2 HP and come with standard NEMA frame sizes.

All models employ direct drive axial fans with a maximum speed of 1,160 rpm. Units include die cast aluminum impellers used for low temperature applications.

The glass reinforced nylon (PAG) impellers are used for medium temperature applications.

Standard voltages are 230V and 460V for 60Hz applications.

ELECTRICAL: Each fan motor is factory wired to an individual, external NEMA 4X junction box. A single point connection is provided on all coolers at a common external NEMA 4X junction box. All external wiring is housed within liquid tight flexible conduit.

Optional Features

CONSTRUCTION MATERIALS

- The entire casing unit, tube sheets and tray are manufactured with either 304 or 316 stainless steel.
- Insulated pan (required by the USDA for certain food / processing applications).
- Epoxy coated aluminum or stainless steel (304 or 316) fins.
- Variable fin spacings.
- Choice of coil handing.
- Units are supplied standard with carbon steel connections but can be ordered with either stainless steel, flanges or threaded connections.
- Powder coated to the color of your choice – dependant on quantity.
- Galvanized steel finish – no paint.
- Intake hoods.
- Re-heat coils – separated from the cooling coil by an air gap.
- Support channel to hang cooler.
- Extended legs.

FANS AND MOTORS

- Two speed, high efficiency or explosion proof motors.
- Blow through option on some models (dimensions will differ).
- 575/3/60 or 400/3/50 motors.

DEFROST OPTIONS

- Hot gas coil only.
- Hot gas coil and pan – series or parallel piped.
- Factory installed check valve for series or parallel flow.
- Water defrost – consult with factory (dimensions will differ).

ELECTRICAL

- No wiring.
- All motors wired to common / individual non-fused disconnect.
- All motors wired to common fused disconnect with thermal protection for each motor.
- All motors wired to fused disconnect with single starter and thermal protection for each motor.
- Various wiring options are available – consult with factory for an alternative to suit your specific requirements.

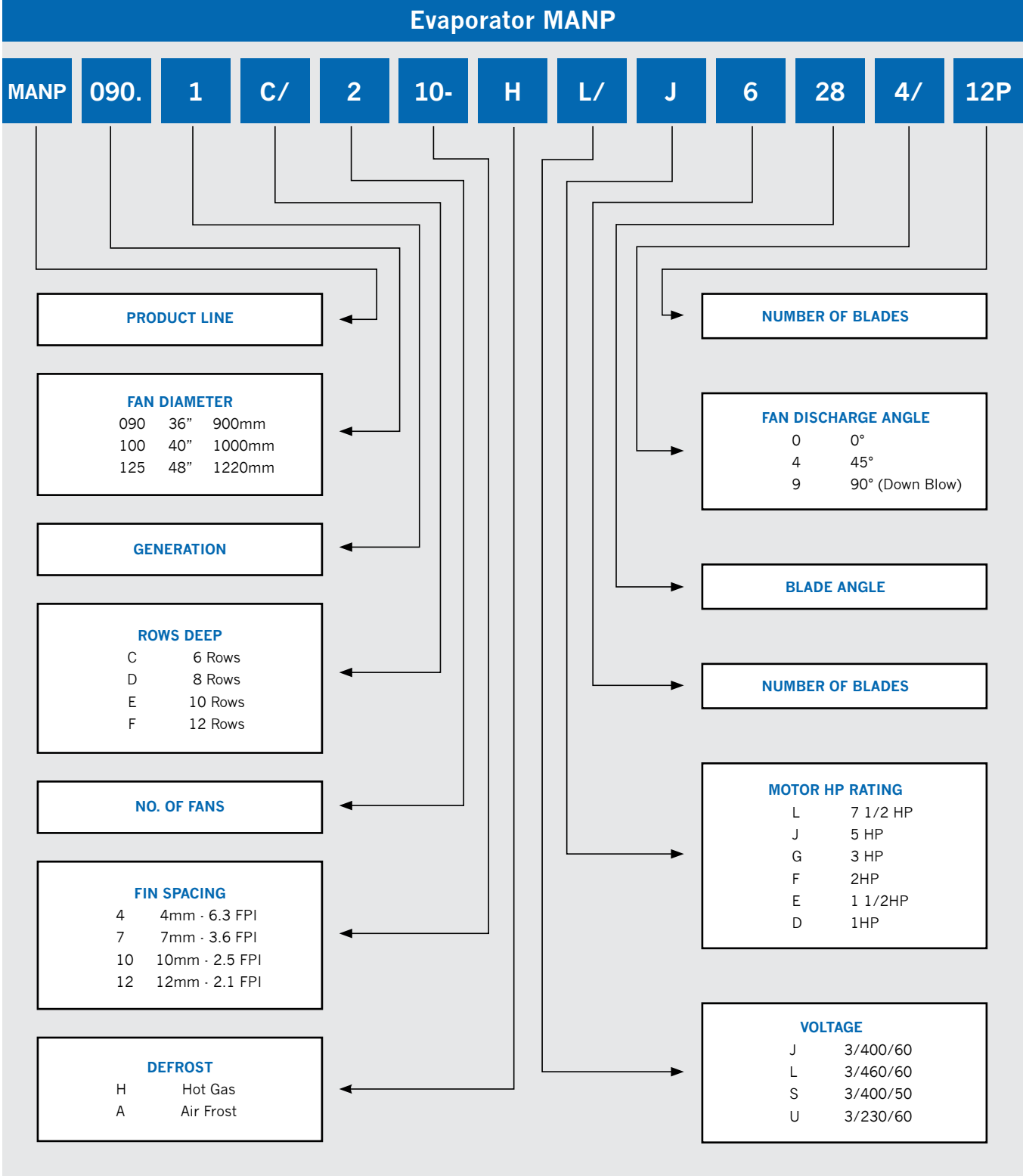

Performance Data: 2 Fan Models

> > HIGH VELOCITY

MODEL NO. MANP	COIL CAPACITY					
	ESP: 0 in H ₂ O		ESP: 1/4 in H ₂ O		ESP: 1/2 in H ₂ O	
	Btu/hr /°F TD	Air Flow cfm	Btu/hr /°F TD	Air Flow cfm	Btu/hr /°F TD	Air Flow cfm
090.1C/27-	18,279	31,571	17,825	29,476	17,265	27,039
090.1D/27-	24,957	30,524	24,386	28,605	23,577	26,168
090.1E/27-	31,555	29,653	30,673	27,475	29,740	25,297
090.1F/27-	37,947	28,782	36,802	26,604	35,631	24,420
100.1D/27-	32,516	39,576	31,807	37,175	30,928	34,444
100.1E/27-	39,349	38,375	38,389	35,974	40,026	33,467
100.1F/27-	49,467	37,281	48,293	34,891	46,874	32,266
125.1D/27-	43,220	52,019	42,150	48,534	40,757	44,320
125.1E/27-	54,523	50,277	53,063	46,651	51,211	42,437
125.1F/27-	65,581	48,676	63,716	45,050	61,406	40,836
090.1C/210-	15,883	32,089	15,420	29,829	15,489	27,475
090.1D/210-	21,830	30,959	21,221	28,840	20,487	26,427
090.1E/210-	27,862	30,347	27,015	28,087	26,088	25,733
090.1F/210-	33,559	29,217	32,614	27,204	31,453	24,862
100.1D/210-	27,868	40,118	27,224	37,834	26,424	35,103
100.1E/210-	35,438	39,023	34,635	36,845	33,570	34,008
100.1F/210-	42,909	38,046	41,853	35,762	40,577	33,031
125.1D/210-	36,136	52,890	35,158	49,405	33,861	45,050
125.1E/210-	47,015	51,148	45,800	47,804	44,071	43,449
125.1F/210-	55,600	49,988	53,811	46,215	51,861	42,142
090.1C/212-	14,398	32,266	14,037	30,347	13,718	28,782
090.1D/212-	19,183	31,489	18,659	29,476	18,727	27,039
090.1E/212-	24,525	30,783	23,843	28,782	23,855	26,168
090.1F/212-	29,761	30,088	28,868	27,910	28,959	25,556
100.1D/212-	24,491	40,777	23,877	38,375	23,590	35,644
100.1E/212-	31,260	39,788	30,498	37,398	29,588	34,773
100.1F/212-	37,936	38,811	36,995	36,516	35,842	33,796
125.1D/212-	31,770	53,914	30,845	50,277	31,013	46,062
125.1E/212-	42,451	52,454	41,209	48,829	39,729	44,614
125.1F/212-	49,167	51,148	47,586	47,369	47,801	43,155



MODEL NO. MANP	COIL			SOUND PRESSURE LEVEL Db(A)	FAN DATA	
	Surface Area	Tube Volume	Fin Spacing		Motor	
	ft ²	ft ³	ft		Hp	RPM
090.1C/27-	3,744	3.04	3.6	85	5	1,160
090.1D/27-	4,992	4.05		85	5	1,160
090.1E/27-	6,240	5.06		85	5	1,160
090.1F/27-	7,488	6.07		85	5	1,160
100.1D/27-	6,240	5.06		87	7 1/2	1,160
100.1E/27-	7,800	6.33		87	7 1/2	1,160
100.1F/27-	9,360	7.59		87	7 1/2	1,160
125.1D/27-	8,321	6.71		86	7 1/2	1,160
125.1E/27-	10,402	8.39		86	7 1/2	1,160
125.1F/27-	12,482	10.07		86	7 1/2	1,160
090.1C/210-	2,696	3.04	2.5	85	5	1,160
090.1D/210-	3,594	4.05		85	5	1,160
090.1E/210-	4,493	5.06		85	5	1,160
090.1F/210-	5,391	6.07		85	5	1,160
100.1D/210-	4,493	5.06		87	7 1/2	1,160
100.1E/210-	5,616	6.33		87	7 1/2	1,160
100.1F/210-	6,739	7.59		87	7 1/2	1,160
125.1D/210-	5,991	6.71		86	7 1/2	1,160
125.1E/210-	7,489	8.39		86	7 1/2	1,160
125.1F/210-	8,987	10.07		86	7 1/2	1,160
090.1C/212-	2,289	3.04	2.1	85	5	1,160
090.1D/212-	3,052	4.05		85	5	1,160
090.1E/212-	3,815	5.06		85	5	1,160
090.1F/212-	4,579	6.07		85	5	1,160
100.1D/212-	3,815	5.06		87	7 1/2	1,160
100.1E/212-	4,769	6.33		87	7 1/2	1,160
100.1F/212-	5,723	7.59		87	7 1/2	1,160
125.1D/212-	5,088	6.71		86	7 1/2	1,160
125.1E/212-	6,360	8.39		86	7 1/2	1,160
125.1F/212-	7,632	10.07		86	7 1/2	1,160

Performance Data: 3 Fan Models

> > HIGH VELOCITY

MODEL NO. MANP	COIL CAPACITY					
	ESP: 0 in H ₂ O		ESP: 1/4 in H ₂ O		ESP: 1/2 in H ₂ O	
	Btu/hr /°F TD	Air Flow cfm	Btu/hr /°F TD	Air Flow cfm	Btu/hr /°F TD	Air Flow cfm
090.1C/37-	28,251	47,357	27,559	44,214	26,715	40,559
090.1D/37-	38,608	45,786	37,668	42,907	36,486	39,252
090.1E/37-	48,736	44,479	47,433	41,212	45,999	37,946
090.1F/37-	58,703	43,172	56,988	39,906	55,209	36,630
100.1D/37-	48,850	59,364	47,761	55,762	46,476	51,666
100.1E/37-	61,720	57,563	60,259	53,961	58,736	50,200
100.1F/37-	74,317	55,921	72,493	52,337	70,502	48,399
125.1D/37-	63,322	78,028	61,761	72,801	62,697	66,480
125.1E/37-	79,863	75,415	77,706	69,976	78,867	63,655
125.1F/37-	96,025	73,013	98,044	67,575	94,534	61,254
090.1C/310-	22,788	48,134	22,131	44,744	23,255	41,212
090.1D/310-	32,215	46,439	31,301	43,261	31,195	39,641
090.1E/310-	41,119	45,521	39,807	42,131	39,667	38,599
090.1F/310-	49,485	43,826	48,078	40,806	47,875	37,292
100.1D/310-	40,849	60,176	39,921	56,751	38,701	52,654
100.1E/310-	51,975	58,534	50,816	55,268	49,175	51,012
100.1F/310-	62,909	57,069	61,375	53,643	59,420	49,547
125.1D/310-	55,676	79,335	54,147	74,108	52,203	67,575
125.1E/310-	70,571	76,721	68,754	71,707	66,158	65,173
125.1F/310-	85,568	74,982	82,961	69,323	79,948	63,213
090.1C/312-	21,593	48,399	21,048	45,521	20,589	43,172
090.1D/312-	29,178	47,234	28,392	44,214	27,406	40,559
090.1E/312-	37,289	46,174	36,276	43,172	34,887	39,252
090.1F/312-	45,269	45,132	43,931	41,866	42,373	38,334
100.1D/312-	37,012	61,165	36,096	57,563	35,020	53,467
100.1E/312-	45,798	59,682	44,635	56,098	43,327	52,160
100.1F/312-	57,336	58,216	55,932	54,773	54,219	50,694
125.1D/312-	48,964	80,871	47,525	75,415	45,822	69,093
125.1E/312-	62,421	78,681	21,661	7,322	58,409	113,700
125.1F/312-	75,724	76,721	73,419	71,053	70,643	109,980



MODEL NO. MANP	COIL			SOUND PRESSURE LEVEL Db(A)	FAN DATA	
	Surface Area	Tube Volume	Fin Spacing		Motor	
	ft ²	ft ³	fpi		Hp	RPM
090.1C/37-	5,633	4.48	3.6	86	5	1,160
090.1D/37-	7,511	5.98		86	5	1,160
090.1E/37-	9,389	7.47		86	5	1,160
090.1F/37-	11,266	8.97		86	5	1,160
100.1D/37-	9,389	7.47		88	7 1/2	1,160
100.1E/37-	11,736	9.34		88	7 1/2	1,160
100.1F/37-	14,083	11.21		88	7 1/2	1,160
125.1D/37-	12,516	9.92		87	7 1/2	1,160
125.1E/37-	15,645	12.40		87	7 1/2	1,160
125.1F/37-	18,774	14.89		87	7 1/2	1,160
090.1C/310-	4,056	4.48	2.5	86	5	1,160
090.1D/310-	5,408	5.98		86	5	1,160
090.1E/310-	6,759	7.47		86	5	1,160
090.1F/310-	8,111	8.97		86	5	1,160
100.1D/310-	6,759	7.47		88	7 1/2	1,160
100.1E/310-	8,449	9.34		88	7 1/2	1,160
100.1F/310-	10,139	11.21		88	7 1/2	1,160
125.1D/310-	9,011	9.92		87	7 1/2	1,160
125.1E/310-	11,264	12.40		87	7 1/2	1,160
125.1F/310-	13,517	14.89		87	7 1/2	1,160
090.1C/312-	3,444	4.48	2.1	86	5	1,160
090.1D/312-	4,592	5.98		86	5	1,160
090.1E/312-	5,741	7.47		86	5	1,160
090.1F/312-	6,889	8.97		86	5	1,160
100.1D/312-	5,741	7.47		88	7 1/2	1,160
100.1E/312-	7,176	9.34		88	7 1/2	1,160
100.1F/312-	8,611	11.21		88	7 1/2	1,160
125.1D/312-	7,653	9.92		87	7 1/2	1,160
125.1E/312-	9,566	12.40		87	7 1/2	1,160
125.1F/312-	11,479	14.89		87	7 1/2	1,160

Performance Data: 4 Fan Models

> > HIGH VELOCITY

MODEL NO. MANP	COIL CAPACITY					
	ESP: 0 in H ₂ O		ESP: 1/4 in H ₂ O		ESP: 1/2 in H ₂ O	
	Btu/hr /°F TD	Air Flow cfm	Btu/hr /°F TD	Air Flow cfm	Btu/hr /°F TD	Air Flow cfm
090.1C/47-	36,588	63,143	35,662	58,952	34,569	54,079
090.1D/47-	49,939	61,048	48,793	57,210	47,170	52,337
090.1E/47-	63,083	59,305	61,364	54,950	59,493	50,594
090.1F/47-	75,924	57,563	73,649	53,208	71,278	48,840
100.1D/47-	63,279	79,152	61,849	74,349	60,156	68,887
100.1E/47-	79,880	76,751	78,036	71,948	75,922	66,933
100.1F/47-	96,113	74,561	93,800	69,782	91,019	64,532
125.1D/47-	86,139	104,037	84,001	97,069	81,297	88,640
125.1E/47-	108,651	100,553	105,847	93,302	102,120	84,873
125.1F/47-	130,698	97,351	126,979	90,100	122,363	81,671
090.1C/410-	31,783	64,179	30,839	59,658	29,820	54,950
090.1D/410-	43,664	61,919	42,474	57,681	40,972	52,854
090.1E/410-	55,716	60,694	54,069	56,174	52,171	51,465
090.1F/410-	67,168	58,434	65,281	54,408	62,894	49,723
100.1D/410-	55,377	80,224	54,086	75,668	52,525	70,206
100.1E/410-	70,442	78,046	68,895	73,690	66,704	68,016
100.1F/410-	85,319	76,092	83,271	71,524	80,633	66,062
125.1D/410-	72,099	105,780	70,084	98,811	67,555	90,100
125.1E/410-	91,441	102,295	88,963	95,609	85,569	86,898
125.1F/410-	110,854	99,976	107,370	92,431	103,382	84,285
090.1C/412-	28,788	64,532	28,061	60,694	27,475	57,563
090.1D/412-	39,871	62,978	38,838	58,952	37,476	54,079
090.1E/412-	49,077	61,565	47,708	57,563	47,690	52,337
090.1F/412-	59,552	60,176	57,719	55,821	57,934	51,112
100.1D/412-	48,672	81,554	47,489	76,751	47,904	71,289
100.1E/412-	62,140	79,576	60,617	74,797	61,119	69,547
100.1F/412-	75,452	77,622	73,564	73,031	74,138	67,593
125.1D/412-	63,314	107,828	64,141	100,553	61,872	92,125
125.1E/412-	80,766	104,908	78,388	97,657	78,829	89,229
125.1F/412-	97,994	102,295	94,917	94,738	95,364	86,309



MODEL NO. MANP	COIL			SOUND PRESSURE LEVEL Db(A)	FAN DATA	
	Surface Area	Tube Volume	Fin Spacing		Motor	
	ft ²	ft ³	fpi		Hp	RPM
090.1C/37-	7,521	5.93	3.6	87	5	1,160
090.1D/37-	10,028	7.91		87	5	1,160
090.1E/37-	12,535	9.88		87	5	1,160
090.1F/37-	15,042	11.86		87	5	1,160
100.1D/37-	12,535	9.88		89	7 1/2	1,160
100.1E/37-	15,669	12.35		89	7 1/2	1,160
100.1F/37-	18,803	14.82		89	7 1/2	1,160
125.1D/37-	16,709	13.13		87	7 1/2	1,160
125.1E/37-	20,886	16.42		87	7 1/2	1,160
125.1F/37-	25,063	19.70		87	7 1/2	1,160
090.1C/310-	5,415	5.93	2.5	87	5	1,160
090.1D/310-	7,220	7.91		87	5	1,160
090.1E/310-	9,025	9.88		87	5	1,160
090.1F/310-	10,830	11.86		87	5	1,160
100.1D/310-	9,025	9.88		89	7 1/2	1,160
100.1E/310-	11,281	12.35		89	7 1/2	1,160
100.1F/310-	13,537	14.82		89	7 1/2	1,160
125.1D/310-	12,030	13.13		87	7 1/2	1,160
125.1E/310-	15,037	16.42		87	7 1/2	1,160
125.1F/310-	18,044	19.70		87	7 1/2	1,160
090.1C/312-	4,599	5.93	2.1	87	5	1,160
090.1D/312-	6,132	7.91		87	5	1,160
090.1E/312-	7,664	9.88		87	5	1,160
090.1F/312-	9,197	11.86		87	5	1,160
100.1D/312-	7,664	9.88		89	7 1/2	1,160
100.1E/312-	9,581	12.35		89	7 1/2	1,160
100.1F/312-	11,497	14.82		89	7 1/2	1,160
125.1D/312-	10,216	13.13		87	7 1/2	1,160
125.1E/312-	12,770	16.42		87	7 1/2	1,160
125.1F/312-	15,325	19.70		87	7 1/2	1,160

Dimensions: 2 Fan Models

> > HIGH VELOCITY

MODEL NO. MANP	UNIT DIMENSIONS									CONNECTIONS				
	L inch	B inch	M inch	H inch	L1 inch	LR inch	SL inch	WB inch	WL inch	Refrigerant		Hot Gas	Drain	Net Weight
										in NPS	out NPS	in NPS	NPT	lb
090.1C/27-	169 1/2	89 1/8	60 5/8	50 1/4	67 1/2	22 1/4	57 1/4	23 1/2	47 1/4	1/2	2	3/4	2	2,661
090.1D/27-	169 1/2	89 1/8	60 5/8	50 1/4	67 1/2	22 1/4	57 1/4	23 1/2	47 1/4	1/2	2	1	2	2,817
090.1E/27-	169 1/2	89 1/8	60 5/8	50 1/4	67 1/2	22 1/4	57 1/4	23 1/2	47 1/4	1/2	2 1/2	1	2	2,987
090.1F/27-	169 1/2	89 1/8	60 5/8	50 1/4	67 1/2	22 1/4	57 1/4	23 1/2	47 1/4	3/4	2 1/2	1	2	3,146
100.1D/27-	169 1/2	91 7/8	72 1/2	62	67 1/2	22 1/4	57 1/4	27	46 1/8	3/4	2 1/2	1	2	3,441
100.1E/27-	169 1/2	91 7/8	72 1/2	62	67 1/2	22 1/4	57 1/4	27	46 1/8	3/4	2 1/2	1 1/4	2	3,649
100.1F/27-	169 1/2	91 7/8	72 1/2	62	67 1/2	22 1/4	57 1/4	27	46 1/8	1	3	1 1/4	2	3,847
125.1D/27-	185	91 1/2	84 1/4	73 3/4	75 1/4	22 1/4	57 1/4	30 1/4	62	3/4	2 1/2	1 1/4	2	3,862
125.1E/27-	185	91 1/2	84 1/4	73 3/4	75 1/4	22 1/4	57 1/4	30 1/4	62	1	3	1 1/4	2	4,145
125.1F/27-	185	91 1/2	84 1/4	73 3/4	75 1/4	22 1/4	57 1/4	30 1/4	62	1	3	1 1/4	2	4,416
090.1C/210	169 1/2	89 1/8	60 5/8	50 1/4	67 1/2	22 1/4	57 1/4	23 1/2	47 1/4	1/2	1 1/4	3/4	2	2,648
090.1D/210	169 1/2	89 1/8	60 5/8	50 1/4	67 1/2	22 1/4	57 1/4	23 1/2	47 1/4	1/2	1 1/2	1	2	2,804
090.1E/210	169 1/2	89 1/8	60 5/8	50 1/4	67 1/2	22 1/4	57 1/4	23 1/2	47 1/4	1/2	2	1	2	2,967
090.1F/210	169 1/2	89 1/8	60 5/8	50 1/4	67 1/2	22 1/4	57 1/4	23 1/2	47 1/4	3/4	2	1	2	3,126
100.1D/210	169 1/2	91 7/8	72 1/2	62	67 1/2	22 1/4	57 1/4	27	46 1/8	3/4	2 1/2	1	2	3,433
100.1E/210	169 1/2	91 7/8	72 1/2	62	67 1/2	22 1/4	57 1/4	27	46 1/8	3/4	2 1/2	1 1/4	2	3,638
100.1F/210	169 1/2	91 7/8	72 1/2	62	67 1/2	22 1/4	57 1/4	27	46 1/8	1	3	1 1/4	2	3,834
125.1D/210	185	91 1/2	84 1/4	73 3/4	75 1/4	22 1/4	57 1/4	30 1/4	62	3/4	2 1/2	1 1/4	2	3,851
125.1E/210	185	91 1/2	84 1/4	73 3/4	75 1/4	22 1/4	57 1/4	30 1/4	62	1	3	1 1/4	2	4,118
125.1F/210	185	91 1/2	84 1/4	73 3/4	75 1/4	22 1/4	57 1/4	30 1/4	62	1	3	1 1/4	2	4,398
090.1C/212	169 1/2	89 1/8	60 5/8	50 1/4	67 1/2	22 1/4	57 1/4	23 1/2	47 1/4	1/2	1 1/4	3/4	2	2,606
090.1D/212	169 1/2	89 1/8	60 5/8	50 1/4	67 1/2	22 1/4	57 1/4	23 1/2	47 1/4	1/2	1 1/2	1	2	2,747
090.1E/212	169 1/2	89 1/8	60 5/8	50 1/4	67 1/2	22 1/4	57 1/4	23 1/2	47 1/4	1/2	2	1	2	2,897
090.1F/212	169 1/2	89 1/8	60 5/8	50 1/4	67 1/2	22 1/4	57 1/4	23 1/2	47 1/4	1/2	2	1	2	3,038
100.1D/212	169 1/2	91 7/8	72 1/2	62	67 1/2	22 1/4	57 1/4	27	46 1/8	1/2	2	1	2	3,362
100.1E/212	169 1/2	91 7/8	72 1/2	62	67 1/2	22 1/4	57 1/4	27	46 1/8	3/4	2 1/2	1 1/4	2	3,538
100.1F/212	169 1/2	91 7/8	72 1/2	62	67 1/2	22 1/4	57 1/4	27	46 1/8	3/4	2 1/2	1 1/4	2	3,726
125.1D/212	185	91 1/2	84 1/4	73 3/4	75 1/4	22 1/4	57 1/4	30 1/4	62	3/4	2 1/2	1 1/4	2	3,746
125.1E/212	185	91 1/2	84 1/4	73 3/4	75 1/4	22 1/4	57 1/4	30 1/4	62	3/4	2 1/2	1 1/4	2	3,999
125.1F/212	185	91 1/2	84 1/4	73 3/4	75 1/4	22 1/4	57 1/4	30 1/4	62	1	3	1 1/4	2	4,242

DRAWINGS FOR ALL MODELS

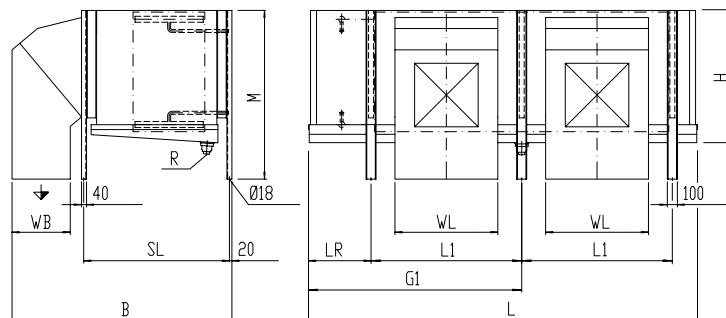

Dimensions: 3 Fan Models

> > HIGH VELOCITY

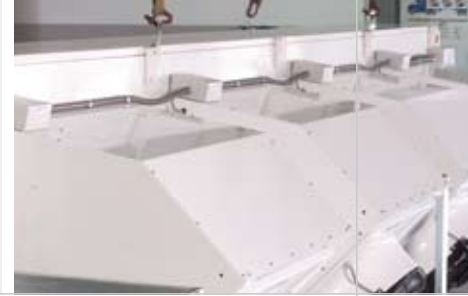

MODEL NO. MANP	UNIT DIMENSIONS									CONNECTIONS				
	L inch	B inch	M inch	H inch	L1 inch	LR inch	SL inch	WB inch	WL inch	Refrigerant		Hot Gas	Drain	Net Weight
										in NPS	out NPS	in NPS	NPT	lb
090.1C/37-	237	89 1/8	60 5/8	50 1/4	67 1/2	22 1/4	57 1/4	23 2/4	47 1/4	1/2	2	1	2x2	3,790
090.1D/37-	237	89 1/8	60 5/8	50 1/4	67 1/2	22 1/4	57 1/4	23 2/4	47 1/4	3/4	2 1/2	1	2x2	4,032
090.1E/37-	237	89 1/8	60 5/8	50 1/4	67 1/2	22 1/4	57 1/4	23 2/4	47 1/4	3/4	2 1/2	1 1/4	2x2	4,275
090.1F/37-	237	89 1/8	60 5/8	50 1/4	67 1/2	22 1/4	57 1/4	23 2/4	47 1/4	1	3	1 1/4	2x2	4,522
100.1D/37-	237	91 7/8	72 1/2	62	67 1/2	22 1/4	57 1/4	27	46 1/8	3/4	2 1/2	1 1/4	2x2	4,932
100.1E/37-	237	91 7/8	72 1/2	62	67 1/2	22 1/4	57 1/4	27	46 1/8	1	3	1 1/4	2x2	5,238
100.1F/37-	237	91 7/8	72 1/2	62	67 1/2	22 1/4	57 1/4	27	46 1/8	1	4	1 1/2	2x2	5,542
125.1D/37-	260 1/4	91 1/2	84 1/4	73 3/4	75 1/4	22 1/4	57 1/4	30 1/4	62	1	3	1 1/4	2x2	5,523
125.1E/37-	260 1/4	91 1/2	84 1/4	73 3/4	75 1/4	22 1/4	57 1/4	30 1/4	62	1	4	1 1/2	2x2	5,935
125.1F/37-	260 1/4	91 1/2	84 1/4	73 3/4	75 1/4	22 1/4	57 1/4	30 1/4	62	1 1/4	4	2	2x2	6,338
090.1C/310	237	89 1/8	60 5/8	50 1/4	67 1/2	22 1/4	57 1/4	23 1/2	47 1/4	1/2	2	1	2x2	3,785
090.1D/310	237	89 1/8	60 5/8	50 1/4	67 1/2	22 1/4	57 1/4	23 1/2	47 1/4	1/2	2	1	2x2	4,023
090.1E/310	237	89 1/8	60 5/8	50 1/4	67 1/2	22 1/4	57 1/4	23 1/2	47 1/4	3/4	2 1/2	1 1/4	2x2	4,261
090.1F/310	237	89 1/8	60 5/8	50 1/4	67 1/2	22 1/4	57 1/4	23 1/2	47 1/4	3/4	2 1/2	1 1/4	2x2	4,502
100.1D/310	237	91 7/8	72 1/2	62	67 1/2	22 1/4	57 1/4	27	46 1/8	3/4	2 1/2	1 1/4	2x2	4,918
100.1E/310	237	91 7/8	72 1/2	62	67 1/2	22 1/4	57 1/4	27	46 1/8	1	3	1 1/4	2x2	5,220
100.1F/310	237	91 7/8	72 1/2	62	67 1/2	22 1/4	57 1/4	27	46 1/8	1	4	1 1/2	2x2	5,523
125.1D/310	260 1/4	91 1/2	84 1/4	73 3/4	75 1/4	22 1/4	57 1/4	30 1/4	62	1	3	1 1/4	2x2	5,505
125.1E/310	260 1/4	91 1/2	84 1/4	73 3/4	75 1/4	22 1/4	57 1/4	30 1/4	62	1	4	1 1/2	2x2	5,913
125.1F/310	260 1/4	91 1/2	84 1/4	73 3/4	75 1/4	22 1/4	57 1/4	30 1/4	62	1 1/4	4	2	2x2	6,312
090.1C/312	237	89 1/8	60 5/8	50 1/4	67 1/2	22 1/4	57 1/4	23 1/2	47 1/4	1/2	2	1	2x2	3,721
090.1D/312	237	89 1/8	60 5/8	50 1/4	67 1/2	22 1/4	57 1/4	23 1/2	47 1/4	1/2	2	1	2x2	3,929
090.1E/312	237	89 1/8	60 5/8	50 1/4	67 1/2	22 1/4	57 1/4	23 1/2	47 1/4	3/4	2 1/2	1 1/4	2x2	4,153
090.1F/312	237	89 1/8	60 5/8	50 1/4	67 1/2	22 1/4	57 1/4	23 1/2	47 1/4	3/4	2 1/2	1 1/4	2x2	4,367
100.1D/312	237	91 7/8	72 1/2	62	67 1/2	22 1/4	57 1/4	27	46 1/8	3/4	2 1/2	1 1/4	2x2	4,810
100.1E/312	237	91 7/8	72 1/2	62	67 1/2	22 1/4	57 1/4	27	46 1/8	3/4	3	1 1/4	2x2	5,084
100.1F/312	237	91 7/8	72 1/2	62	67 1/2	22 1/4	57 1/4	27	46 1/8	1	4	1 1/2	2x2	5,353
125.1D/312	260 1/4	91 1/2	84 1/4	73 3/4	75 1/4	22 1/4	57 1/4	30 1/4	62	3/4	3	1 1/4	2x2	5,357
125.1E/312	260 1/4	91 1/2	84 1/4	73 3/4	75 1/4	22 1/4	57 1/4	30 1/4	62	1	4	1 1/2	2x2	5,736
125.1F/312	260 1/4	91 1/2	84 1/4	73 3/4	75 1/4	22 1/4	57 1/4	30 1/4	62	1	4	2	2x2	6,100

DRAWINGS FOR ALL MODELS

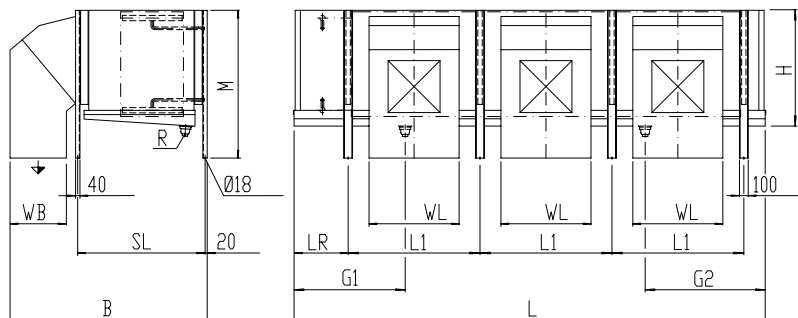

Dimensions: 4 Fan Models

> > HIGH VELOCITY

MODEL NO. MANP	UNIT DIMENSIONS									CONNECTIONS				Net Weight lb
	L inch	B inch	M inch	H inch	L1 inch	LR inch	SL inch	WB inch	WL inch	Refrigerant		Hot Gas	Drain	
										in NPS	out NPS	in NPS	NPT	
090.1C/47-	304 1/2	89 1/8	60 5/8	50 1/4	67 1/2	22 1/4	57 1/4	23 1/2	47 1/4	1/2	2	1	2x2	4,932
090.1D/47-	304 1/2	89 1/8	60 5/8	50 1/4	67 1/2	22 1/4	57 1/4	23 1/2	47 1/4	3/4	2 1/2	1 1/4	2x2	5,247
090.1E/47-	304 1/2	89 1/8	60 5/8	50 1/4	67 1/2	22 1/4	57 1/4	23 1/2	47 1/4	3/4	2 1/2	1 1/4	2x2	5,580
090.1F/47-	304 1/2	89 1/8	60 5/8	50 1/4	67 1/2	22 1/4	57 1/4	23 1/2	47 1/4	1	3	1 1/2	2x2	5,895
100.1D/47-	304 1/2	91 7/8	72 1/2	62	67 1/2	22 1/4	57 1/4	27	46 1/8	3/4	2 1/2	1 1/4	2x2	6,433
100.1E/47-	304 1/2	91 7/8	72 1/2	62	67 1/2	22 1/4	57 1/4	27	46 1/8	1	3	1 1/2	2x2	6,825
100.1F/47-	304 1/2	91 7/8	72 1/2	62	67 1/2	22 1/4	57 1/4	27	46 1/8	1	4	2	2x2	7,218
125.1D/47-	335 1/2	91 1/2	84 1/4	73 3/4	75 1/4	22 1/4	57 1/4	30 1/4	62	1	3	1 1/2	2x2	7,180
125.1E/47-	335 1/2	91 1/2	84 1/4	73 3/4	75 1/4	22 1/4	57 1/4	30 1/4	62	1	4	2	2x2	7,714
125.1F/47-	335 1/2	91 1/2	84 1/4	73 3/4	75 1/4	22 1/4	57 1/4	30 1/4	62	1 1/4	4	2	2x2	8,261
090.1C/410	304 1/2	89 1/8	60 3/4	50 1/4	67 1/2	22 1/4	57 1/4	23 1/2	47 1/4	3/4	2	1	2x2	4,914
090.1D/410	304 1/2	89 1/8	60 3/4	50 1/4	67 1/2	22 1/4	57 1/4	23 1/2	47 1/4	3/4	2 1/2	1 1/4	2x2	5,227
090.1E/410	304 1/2	89 1/8	60 3/4	50 1/4	67 1/2	22 1/4	57 1/4	23 1/2	47 1/4	1	2 1/2	1 1/4	2x2	5,547
090.1F/410	304 1/2	89 1/8	60 3/4	50 1/4	67 1/2	22 1/4	57 1/4	23 1/2	47 1/4	1	3	1 1/2	2x2	5,864
100.1D/410	304 1/2	91 7/8	72 1/2	62	67 1/2	22 1/4	57 1/4	27	46 1/8	1	2 1/2	1 1/4	2x2	6,398
100.1E/410	304 1/2	91 7/8	72 1/2	62	67 1/2	22 1/4	57 1/4	27	46 1/8	1	3	1 1/2	2x2	6,792
100.1F/410	304 1/2	91 7/8	72 1/2	62	67 1/2	22 1/4	57 1/4	27	46 1/8	1	4	2	2x2	7,191
125.1D/410	335 1/2	91 1/2	84 1/4	73 3/4	75 1/4	22 1/4	57 1/4	30 1/4	62	1	3	1 1/2	2x2	7,156
125.1E/410	335 1/2	91 1/2	84 1/4	73 3/4	75 1/4	22 1/4	57 1/4	30 1/4	62	1 1/4	4	2	2x2	7,683
125.1F/410	335 1/2	91 1/2	84 1/4	73 3/4	75 1/4	22 1/4	57 1/4	30 1/4	62	1 1/4	4	2	2x2	8,225
090.1C/412	304 1/2	89 1/8	60 5/8	50 1/4	67 1/2	22 1/4	57 1/4	23 1/2	47 1/4	1/2	2	1	2x2	4,826
090.1D/412	304 1/2	89 1/8	60 5/8	50 1/4	67 1/2	22 1/4	57 1/4	23 1/2	47 1/4	3/4	2 1/2	1 1/4	2x2	5,112
090.1E/412	304 1/2	89 1/8	60 5/8	50 1/4	67 1/2	22 1/4	57 1/4	23 1/2	47 1/4	3/4	2 1/2	1 1/4	2x2	5,401
090.1F/412	304 1/2	89 1/8	60 5/8	50 1/4	67 1/2	22 1/4	57 1/4	23 1/2	47 1/4	1	3	1 1/2	2x2	5,694
100.1D/412	304 1/2	91 7/8	72 1/2	62	67 1/2	22 1/4	57 1/4	27	46 1/8	3/4	2 1/2	1 1/4	2x2	6,250
100.1E/412	304 1/2	91 7/8	72 1/2	62	67 1/2	22 1/4	57 1/4	27	46 1/8	1	3	1 1/2	2x2	6,614
100.1F/412	304 1/2	91 7/8	72 1/2	62	67 1/2	22 1/4	57 1/4	27	46 1/8	1	4	2	2x2	6,975
125.1D/412	335 1/2	91 1/2	84 1/4	73 3/4	75 1/4	22 1/4	57 1/4	30 1/4	62	1	3	1 1/2	2x2	6,953
125.1E/412	335 1/2	91 1/2	84 1/4	73 3/4	75 1/4	22 1/4	57 1/4	30 1/4	62	1	4	2	2x2	7,445
125.1F/412	335 1/2	91 1/2	84 1/4	73 3/4	75 1/4	22 1/4	57 1/4	30 1/4	62	1 1/4	4	2	2x2	7,928

DRAWINGS FOR ALL MODELS

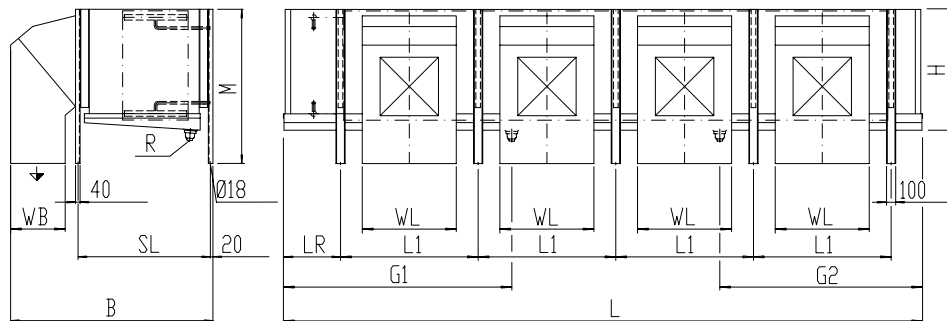

Options for Fan Discharge

> > HIGH VELOCITY



DRAWINGS FOR ALL MODELS

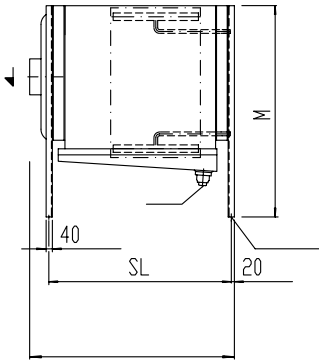

0° ANGLE

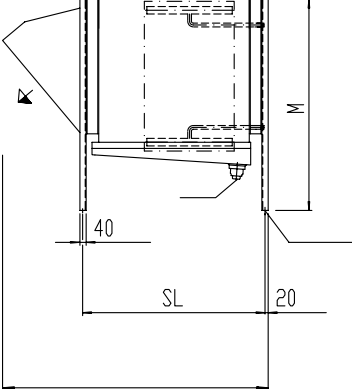

45° ANGLE

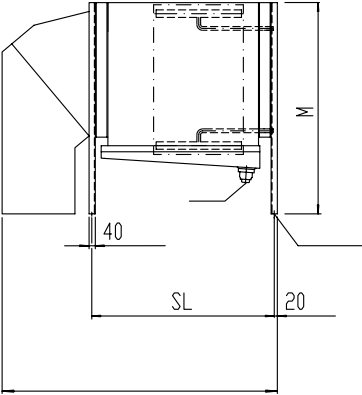

90° ANGLE

Performance Data: 2 Fan Models

> > LOW VELOCITY

MODEL NO. MANP	COIL CAPACITY					
	ESP: 0 in H ₂ O		ESP: 1/4 in H ₂ O		ESP: 1/2 in H ₂ O	
	Btu/hr /°F TD	Air Flow cfm	Btu/hr /°F TD	Air Flow cfm	Btu/hr /°F TD	Air Flow cfm
090.1C/24-	32,009	20,930	31,609	20,059	31,694	20,235
100.1B/24-	33,117	27,251	32,737	26,168	31,982	24,096
100.1C/24-	40,278	26,380	39,949	25,615	38,947	23,437
100.1D/24-	53,524	25,403	52,783	24,202	51,544	22,342
125.1C/24-	52,096	33,420	51,771	32,702	53,028	35,597
125.1D/24-	70,085	31,677	69,323	30,512	71,216	33,420
125.1E/24-	87,250	29,935	85,976	28,476	88,745	31,677
125.1F/24-	103,206	28,334	101,520	26,886	105,540	30,371
090.1C/27-	21,170	22,496	20,917	21,624	21,021	21,978
090.1D/27-	29,014	21,624	28,648	20,753	28,783	21,106
100.1C/27-	26,199	28,346	25,878	27,251	25,282	25,297
100.1D/27-	36,362	27,251	35,977	26,380	35,101	24,308
100.1E/27-	45,597	26,380	45,112	25,509	43,955	23,437
125.1C/27-	35,314	35,750	35,246	35,597	36,015	38,069
125.1D/27-	48,310	34,008	48,241	33,855	49,391	36,621
125.1E/27-	60,938	33,420	60,453	32,548	62,009	35,315
125.1F/27-	72,289	32,254	71,551	31,242	75,834	34,149
090.1D/210-	23,496	21,978	23,207	21,189	23,368	21,624
090.1E/210-	29,251	19,753	29,600	20,494	29,781	20,930
100.1C/210-	21,308	28,676	21,033	27,581	20,501	25,615
100.1D/210-	29,445	27,805	29,097	26,816	28,384	24,862
100.1E/210-	37,558	26,922	37,116	25,945	36,156	23,979
125.1C/210-	28,426	36,468	28,390	36,327	29,020	38,799
125.1D/210-	39,208	35,162	38,992	34,585	40,010	37,351
125.1E/210-	49,538	34,149	49,191	33,420	50,554	36,327
125.1F/210-	60,989	33,278	60,357	32,254	61,888	34,879

MODEL NO. MANP	COIL			SOUND PRESSURE LEVEL Db(A)	FAN DATA					
	Surface Area ft ²	Tube Volume ft ³	Fin Spacing fpi		Motor					
					Esp: 0		Esp: 1/4		Esp: 1/2	
				Hp	RPM	Hp	RPM	Hp	RPM	
090.1C/24-	6,359	3.04	6.3	77	1 1/2	1,160	2	1,160	3	1,160
100.1B/24-	6,624	3.16		78	2	1,160	3	1,160	3	1,160
100.1C/24-	7,949	3.80		78	2	1,160	3	1,160	3	1,160
100.1D/24-	10,598	5.06		78	2	1,160	3	1,160	3	1,160
125.1C/24-	10,600	5.03		77	2	850	3	850	5	1,160
125.1D/24-	14,133	6.71		77	2	850	3	850	5	1,160
125.1E/24-	17,666	8.39		77	2	850	3	850	5	1,160
125.1F/24-	21,199	10.07		77	2	850	3	850	5	1,160
090.1C/27-	3,744	3.04	3.6	77	1 1/2	1,160	2	1,160	3	1,160
090.1D/27-	4,992	4.05		77	1 1/2	1,160	2	1,160	3	1,160
100.1C/27-	4,680	3.80		78	2	1,160	3	1,160	3	1,160
100.1D/27-	6,240	5.06		78	2	1,160	3	1,160	3	1,160
100.1E/27-	7,800	6.33		78	2	1,160	3	1,160	3	1,160
125.1C/27-	6,241	5.03		77	2	850	3	850	5	1,160
125.1D/27-	8,321	6.71		77	2	850	3	850	5	1,160
125.1E/27-	10,402	8.39		77	2	850	3	850	5	1,160
125.1F/27-	12,482	10.07	77	2	850	3	850	5	1,160	
090.1D/210-	3,594	4.05	2.5	77	1 1/2	1,160	2	1,160	3	1,160
090.1E/210-	4,493	5.06		77	1 1/2	1,160	2	1,160	3	1,160
100.1C/210-	3,369	3.80		78	2	1,160	3	1,160	3	1,160
100.1D/210-	4,493	5.06		78	2	1,160	3	1,160	3	1,160
100.1E/210-	5,172	5.86		78	2	1,160	3	1,160	3	1,160
125.1C/210-	4,493	5.03		77	2	850	3	850	5	1,160
125.1D/210-	5,991	6.71		77	2	850	3	850	5	1,160
125.1E/210-	7,489	8.39		77	2	850	3	850	5	1,160
125.1F/210-	8,987	10.07	78	2	850	3	850	5	1,160	

Performance Data: 3 Fan Models

> > LOW VELOCITY

MODEL NO. MANP	COIL CAPACITY					
	ESP: 0 in H ₂ O		ESP: 1/4 in H ₂ O		ESP: 1/2 in H ₂ O	
	Btu/hr /°F TD	Air Flow cfm	Btu/hr /°F TD	Air Flow cfm	Btu/hr /°F TD	Air Flow cfm
090.1C/34-	47,285	31,395	46,715	30,088	46,847	30,353
100.1B/34-	48,749	40,877	48,184	39,252	47,023	36,145
100.1C/34-	59,270	39,570	58,757	38,423	57,281	35,156
100.1D/34-	76,677	27,510	83,202	36,304	81,328	33,514
125.1C/34-	79,691	50,129	79,196	49,052	81,149	53,396
125.1D/34-	107,670	47,516	106,483	45,768	109,305	50,129
125.1E/34-	134,165	44,903	132,045	42,713	136,425	47,516
125.1F/34-	158,947	42,501	156,315	40,330	162,626	45,556
090.1C/37-	31,761	33,743	31,380	32,437	31,536	32,966
090.1D/37-	43,528	32,437	42,972	31,130	43,190	31,660
100.1C/37-	39,492	42,519	39,047	40,877	38,155	37,946
100.1D/37-	54,552	40,877	53,986	39,570	52,691	36,463
100.1E/37-	68,737	39,570	68,081	38,264	66,365	35,156
125.1C/37-	50,847	53,626	50,777	53,396	51,888	57,104
125.1D/37-	71,098	51,012	70,992	50,783	72,715	54,932
125.1E/37-	88,533	50,129	87,882	48,823	90,090	52,972
125.1F/37-	109,535	48,381	108,498	46,863	111,585	51,224
090.1D/310-	35,236	32,966	34,828	31,783	35,044	32,437
090.1E/310-	43,871	29,629	44,395	30,742	44,695	31,395
100.1C/310-	32,795	43,013	32,380	41,371	31,569	38,423
100.1D/310-	44,835	41,707	44,301	40,224	43,175	37,292
100.1E/310-	55,848	40,118	57,149	38,917	55,760	35,968
125.1C/310-	40,910	54,703	40,855	54,491	41,762	58,199
125.1D/310-	58,854	52,743	58,528	51,877	60,073	56,027
125.1E/310-	74,703	51,224	74,182	50,129	76,230	54,491
125.1F/310-	91,416	49,917	90,596	48,381	92,899	52,319



MODEL NO. MANP	COIL			SOUND PRESSURE LEVEL Db(A)	FAN DATA					
	Surface Area ft ²	Tube Volume ft ³	Fin Spacing fpi		Motor					
					Esp: 0		Esp: 1/4		Esp: 1/2	
Hp	RPM	Hp	RPM	Hp	RPM					
090.1C/34-	9,567	4.5	6.3	78	1 1/2	1,160	2	1,160	3	1,160
100.1B/34-	9,966	4.7		79	2	1,160	3	1,160	3	1,160
100.1C/34-	11,959	5.6		79	2	1,160	3	1,160	3	1,160
100.1D/34-	15,945	7.5		79	2	1,160	3	1,160	3	1,160
125.1C/34-	15,943	7.4		78	2	850	3	850	5	1,160
125.1D/34-	21,257	9.9		78	2	850	3	850	5	1,160
125.1E/34-	26,571	12.4		78	2	850	3	850	5	1,160
125.1F/34-	31,885	14.9		78	2	850	3	850	5	1,160
090.1C/37-	5,633	4.5	3.6	78	1 1/2	1,160	2	1,160	3	1,160
090.1D/37-	7,511	6.0		78	1 1/2	1,160	2	1,160	3	1,160
100.1C/37-	7,041	5.6		79	2	1,160	3	1,160	3	1,160
100.1D/37-	9,389	7.5		79	2	1,160	3	1,160	3	1,160
100.1E/37-	11,736	9.3		79	2	1,160	3	1,160	3	1,160
125.1C/37-	9,387	7.4		78	2	850	3	850	5	1,160
125.1D/37-	12,516	9.9		78	2	850	3	850	5	1,160
125.1E/37-	15,645	12.4		78	2	850	3	850	5	1,160
125.1F/37-	18,774	14.9	78	2	850	3	850	5	1,160	
090.1D/310-	5,408	6.0	2.5	78	1 1/2	1,160	2	1,160	3	1,160
090.1E/310-	6,759	7.5		78	1 1/2	1,160	2	1,160	3	1,160
100.1C/310-	5,070	5.6		79	2	1,160	3	1,160	3	1,160
100.1D/310-	6,759	7.5		79	2	1,160	3	1,160	3	1,160
100.1E/310-	8,449	9.3		79	2	1,160	3	1,160	3	1,160
125.1C/310-	6,758	7.4		78	2	850	3	850	5	1,160
125.1D/310-	9,011	9.9		78	2	850	3	850	5	1,160
125.1E/310-	11,264	12.4		78	2	850	3	850	5	1,160
125.1F/310-	13,517	14.9	78	2	850	3	850	5	1,160	

Performance Data: 4 Fan Models

> > LOW VELOCITY

MODEL NO. MANP	COIL CAPACITY					
	ESP: 0 in H ₂ O		ESP: 1/4 in H ₂ O		ESP: 1/2 in H ₂ O	
	Btu/hr /°F TD	Air Flow cfm	Btu/hr /°F TD	Air Flow cfm	Btu/hr /°F TD	Air Flow cfm
090.1C/44-	64,026	41,860	63,222	40,118	63,394	40,471
100.1B/44-	65,906	54,503	65,188	52,337	65,636	48,193
100.1C/44-	80,168	52,760	79,566	51,230	77,570	46,875
100.1D/44-	108,800	50,806	107,373	48,405	104,857	44,685
125.1C/44-	103,549	66,839	102,898	65,403	105,369	71,195
125.1D/44-	139,629	63,355	138,198	61,024	141,885	66,839
125.1E/44-	173,838	59,870	171,297	56,951	176,854	63,355
125.1F/44-	205,785	56,668	202,291	53,773	210,450	60,741
090.1C/47-	42,334	44,991	41,857	43,249	42,065	43,955
090.1D/47-	58,060	43,249	57,282	41,507	57,609	42,213
100.1C/47-	53,046	56,692	52,452	54,503	51,212	50,594
100.1D/47-	72,710	54,503	72,009	52,760	70,183	48,617
100.1E/47-	92,405	52,760	91,455	51,018	89,118	46,875
125.1C/47-	68,480	71,501	68,388	71,195	69,861	76,139
125.1D/47-	93,609	68,016	93,468	67,710	95,761	73,243
125.1E/47-	119,336	66,839	118,366	65,097	121,353	70,630
125.1F/47-	144,094	64,508	142,649	62,484	146,736	68,299
090.1D/410-	46,964	43,955	46,448	42,378	46,736	43,249
090.1E/410-	58,509	39,505	59,164	40,989	59,609	41,860
100.1C/410-	42,624	57,351	42,073	55,162	41,031	51,230
100.1D/410-	58,901	55,609	58,214	53,631	57,782	49,723
100.1E/410-	75,130	53,843	74,245	51,889	72,319	47,957
125.1C/410-	56,681	72,937	56,609	72,654	57,912	77,598
125.1D/410-	78,223	70,324	77,828	69,170	79,808	74,703
125.1E/410-	99,990	68,299	99,228	66,839	101,948	72,654
125.1F/410-	121,550	66,557	120,367	64,508	123,427	69,759

MODEL NO. MANP	COIL			SOUND PRESSURE LEVEL Db(A)	FAN DATA					
	Surface Area ft ²	Tube Volume ft ³	Fin Spacing fpi		Motor					
					Esp: 0		Esp: 1/4		Esp: 1/2	
				Hp	RPM	Hp	RPM	Hp	RPM	
090.1C/44-	12773	5.9	6.3	79	1 1/2	1,160	2	1,160	3	1,160
100.1B/44-	13306	6.2		80	2	1,160	3	1,160	3	1,160
100.1C/44-	15967	7.4		80	2	1,160	3	1,160	3	1,160
100.1D/44-	21289	9.9		80	2	1,160	3	1,160	3	1,160
125.1C/44-	21283	9.9		78	2	850	3	850	5	1,160
125.1D/44-	28377	13.1		78	2	850	3	850	5	1,160
125.1E/44-	35472	16.4		78	2	850	3	850	5	1,160
125.1F/44-	42566	19.7		78	2	850	3	850	5	1,160
090.1C/47-	7521	5.9	3.6	79	1 1/2	1,160	2	1,160	3	1,160
090.1D/47-	10028	7.9		79	1 1/2	1,160	2	1,160	3	1,160
100.1C/47-	9401	7.4		80	2	1,160	3	1,160	3	1,160
100.1D/47-	12535	9.9		80	2	1,160	3	1,160	3	1,160
100.1E/47-	15669	12.4		80	2	1,160	3	1,160	3	1,160
125.1C/47-	12531	9.9		78	2	850	3	850	5	1,160
125.1D/47-	16709	13.1		78	2	850	3	850	5	1,160
125.1E/47-	20886	16.4		78	2	850	3	850	5	1,160
125.1F/47-	25063	19.7	78	2	850	3	850	5	1,160	
090.1D/410-	7220	7.9	2.5	79	1 1/2	1,160	2	1,160	3	1,160
090.1E/410-	9025	9.9		79	1 1/2	1,160	2	1,160	3	1,160
100.1C/410-	6769	7.4		80	2	1,160	3	1,160	3	1,160
100.1D/410-	9025	9.9		80	2	1,160	3	1,160	3	1,160
100.1E/410-	11281	12.4		80	2	1,160	3	1,160	3	1,160
125.1C/410-	9022	9.9		78	2	850	3	850	5	1,160
125.1D/410-	12030	13.1		78	2	850	3	850	5	1,160
125.1E/410-	15037	16.4		78	2	850	3	850	5	1,160
125.1F/410-	18044	19.7	78	2	850	3	850	5	1,160	

Dimensions: 2 Fan Models

>> LOW VELOCITY

MODEL NO. MANP	UNIT DIMENSIONS									CONNECTIONS				
	L inch	B inch	M inch	H inch	L1 inch	LR inch	SL inch	WB inch	WL inch	Refrigerant		Hot Gas	Drain	Net Weight
										in NPS	out NPS	in NPS	NPT	lb
090.1C/24-	169 1/2	89 1/4	60 5/8	50 1/4	67 1/2	22 1/4	57 1/4	23 1/2	47 1/4	3/4	2	3/4	2	2,831
100.1B/24-	169 1/2	91 7/8	72 1/2	62	67 1/2	22 1/4	57 1/4	27	46 1/8	3/4	2 1/2	3/4	2	3,078
100.1C/24-	169 1/2	91 7/8	72 1/2	62	67 1/2	22 1/4	57 1/4	27	46 1/8	3/4	2 1/2	1	2	3,221
100.1D/24-	169 1/2	91 7/8	72 1/2	62	67 1/2	22 1/4	57 1/4	27	46 1/8	1	3	1	2	3,510
125.1C/24-	185	91 1/2	84 1/4	73 3/4	75 1/4	22 1/4	57 1/4	30 1/4	62	1	2 1/2	1	2	3,679
125.1D/24-	185	91 1/2	84 1/4	73 3/4	75 1/4	22 1/4	57 1/4	30 1/4	62	1	3	1 1/4	2	4,072
125.1E/24-	185	91 1/2	84 1/4	73 3/4	75 1/4	22 1/4	57 1/4	30 1/4	62	1	3	1 1/4	2	4,451
125.1F/24-	185	91 1/2	84 1/4	73 3/4	75 1/4	22 1/4	57 1/4	30 1/4	62	1 1/4	4	1 1/4	2	4,839
090.1C/27-	169 1/2	89 1/4	60 5/8	50 1/4	67 1/2	22 1/4	57 1/4	23 1/2	47 1/4	1/2	2	3/4	2	2,632
090.1D/27-	169 1/2	89 1/4	60 5/8	50 1/4	67 1/2	22 1/4	57 1/4	23 1/2	47 1/4	3/4	2 1/2	1	2	2,798
100.1C/27-	169 1/2	91 7/8	72 1/2	62	67 1/2	22 1/4	57 1/4	27	46 1/8	3/4	2 1/2	1	2	2,972
100.1D/27-	169 1/2	91 7/8	72 1/2	62	67 1/2	22 1/4	57 1/4	27	46 1/8	1/2	2	1	2	3,172
100.1E/27-	169 1/2	91 7/8	72 1/2	62	67 1/2	22 1/4	57 1/4	27	46 1/8	1	3	1 1/4	2	3,382
125.1C/27-	185	91 1/2	84 1/4	73 3/4	75 1/4	22 1/4	57 1/4	30 1/4	62	1/2	2	1	2	3,349
125.1D/27-	185	91 1/2	84 1/4	73 3/4	75 1/4	22 1/4	57 1/4	30 1/4	62	3/4	2 1/2	1 1/4	2	3,624
125.1E/27-	185	91 1/2	84 1/4	73 3/4	75 1/4	22 1/4	57 1/4	30 1/4	62	1	3	1 1/4	2	3,893
125.1F/27-	185	91 1/2	84 1/4	73 3/4	75 1/4	22 1/4	57 1/4	30 1/4	62	1 1/4	4	1 1/4	2	4,173
090.1D/210-	169 1/2	89 1/4	60 5/8	50 1/4	67 1/2	22 1/4	57 1/4	23 1/2	47 1/4	3/4	2 1/2	1	2	2,791
090.1E/210-	169 1/2	89 1/4	60 5/8	50 1/4	67 1/2	22 1/4	57 1/4	23 1/2	47 1/4	3/4	2 1/2	1	2	2,950
100.1C/210-	169 1/2	91 7/8	72 1/2	62	67 1/2	22 1/4	57 1/4	27	46 1/8	3/4	2 1/2	1	2	2,965
100.1D/210-	169 1/2	91 7/8	72 1/2	62	67 1/2	22 1/4	57 1/4	27	46 1/8	3/4	2	1	2	3,155
100.1E/210-	169 1/2	91 7/8	72 1/2	62	67 1/2	22 1/4	57 1/4	27	46 1/8	1	3	1 1/4	2	3,371
125.1C/210-	185	91 1/2	84 1/4	73 3/4	75 1/4	22 1/4	57 1/4	30 1/4	62	1/2	2	1	2	3,340
125.1D/210-	185	91 1/2	84 1/4	73 3/4	75 1/4	22 1/4	57 1/4	30 1/4	62	1	3	1 1/4	2	3,613
125.1E/210-	185	91 1/2	84 1/4	73 3/4	75 1/4	22 1/4	57 1/4	30 1/4	62	1	3	1 1/4	2x2	3,880
125.1F/210-	185	91 1/2	84 1/4	73 3/4	75 1/4	22 1/4	57 1/4	30 1/4	62	1 3/4	4	1 1/4	2x2	4,156

DRAWINGS FOR ALL MODELS

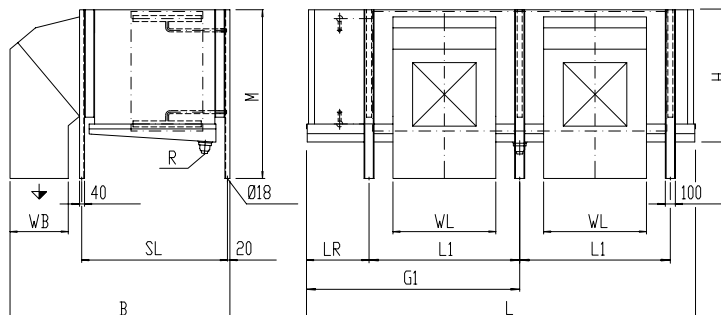

Dimensions: 3 Fan Models

> > LOW VELOCITY



MODEL NO. MANP	UNIT DIMENSIONS									CONNECTIONS				
	L inch	B inch	M inch	H inch	L1 inch	LR inch	SL inch	WB inch	WL inch	Refrigerant		Hot Gas	Drain	Net Weight
										in NPS	out NPS	in NPS	NPT	lb
090.1C/34-	237	89 1/4	60 5/8	50 1/4	67 1/2	0	57 1/4	23 1/2	47 1/4	1	2 1/2	1	2x2	4,059
100.1B/34-	237	91 7/8	72 1/2	62	67 1/2	0	57 1/4	27	46 1/8	3/4	2 1/2	1	2x2	4,387
100.1C/34-	237	91 7/8	72 1/2	62	67 1/2	0	57 1/4	27	46 1/8	3/4	2 1/2	1	2x2	4,594
100.1D/34-	237	91 7/8	72 1/2	62	67 1/2	0	57 1/4	27	46 1/8	1	3	1 1/4	2x2	5,018
125.1C/34-	260 1/4	91 1/2	84 1/4	73 3/4	75 1/4	0	57 1/4	30 1/4	62	1 1/4	4	1 1/4	2x2	5,256
125.1D/34-	260 1/4	91 1/2	84 1/4	73 3/4	75 1/4	0	57 1/4	30 1/4	62	1 1/4	4	1 1/4	2x2	5,811
125.1E/34-	260 1/4	91 1/2	84 1/4	73 3/4	75 1/4	0	57 1/4	30 1/4	62	1 1/4	4	1 1/2	2x2	6,389
125.1F/34-	260 1/4	91 1/2	84 1/4	73 3/4	75 1/4	0	57 1/4	30 1/4	62	1 1/4	5	2	2x2	6,953
090.1C/37-	237	89 1/4	60 5/8	50 1/4	67 1/2	0	57 1/4	23 1/2	47 1/4	3/4	2 1/2	1	2x2	3,761
090.1D/37-	237	89 1/4	60 5/8	50 1/4	67 1/2	0	57 1/4	23 1/2	47 1/4	3/4	2 1/2	1	2x2	4,001
100.1C/37-	237	91 7/8	72 1/2	62	67 1/2	0	57 1/4	27	46 1/8	1	2 1/2	1	2x2	4,217
100.1D/37-	237	91 7/8	72 1/2	62	67 1/2	0	57 1/4	27	46 1/8	1	3	1 1/4	2x2	4,526
100.1E/37-	237	91 7/8	72 1/2	62	67 1/2	0	57 1/4	27	46 1/8	1 1/4	3	1 1/4	2x2	4,821
125.1C/37-	260 1/4	91 1/2	84 1/4	73 3/4	75 1/4	0	57 1/4	30 1/4	62	3/4	2 1/2	1 1/4	2x2	4,764
125.1D/37-	260 1/4	91 1/2	84 1/4	73 3/4	75 1/4	0	57 1/4	30 1/4	62	1 1/4	4	1 1/4	2x2	5,157
125.1E/37-	260 1/4	91 1/2	84 1/4	73 3/4	75 1/4	0	57 1/4	30 1/4	62	1 1/4	4	1 1/2	2x2	5,569
125.1F/37-	260 1/4	91 1/2	84 1/4	73 3/4	75 1/4	0	57 1/4	30 1/4	62	1 1/4	5	2	2x2	5,970
090.1D/310-	237	89 1/4	60 5/8	50 1/4	67 1/2	0	57 1/4	23 1/2	47 1/4	1	3	1	2x2	3,990
090.1E/310-	237	89 1/4	60 5/8	50 1/4	67 1/2	0	57 1/4	23 1/2	47 1/4	3/4	2 1/2	1	2x2	4,231
100.1C/310-	237	91 7/8	72 1/2	62	67 1/2	0	57 1/4	27	46 1/8	3/4	2 1/2	1	2x2	4,204
100.1D/310-	237	91 7/8	72 1/2	62	67 1/2	0	57 1/4	27	46 1/8	1	3	1 1/4	2x2	4,513
100.1E/310-	237	91 7/8	72 1/2	62	67 1/2	0	57 1/4	27	46 1/8	1	3	1 1/4	2x2	4,804
125.1C/310-	260 1/4	91 1/2	84 1/4	73 3/4	75 1/4	0	57 1/4	30 1/4	62	3/4	2 1/2	1 1/4	2x2	4,751
125.1D/310-	260 1/4	91 1/2	84 1/4	73 3/4	75 1/4	0	57 1/4	30 1/4	62	1	3	1 1/4	2x2	5,139
125.1E/310-	260 1/4	91 1/2	84 1/4	73 3/4	75 1/4	0	57 1/4	30 1/4	62	1 1/4	4	1 1/4	2x2	5,536
125.1F/310-	260 1/4	91 1/2	84 1/4	73 3/4	75 1/4	0	57 1/4	30 1/4	62	1 1/4	4	2	2x2	5,944

DRAWINGS FOR ALL MODELS

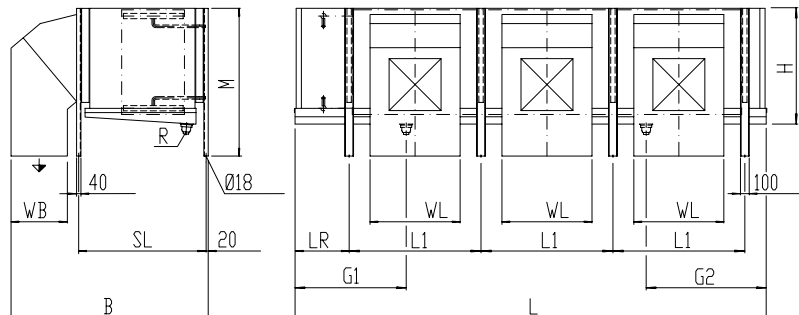

Dimensions: 4 Fan Models

> > LOW VELOCITY

MODEL NO. MANP	UNIT DIMENSIONS									CONNECTIONS				Net Weight lb
	L inch	B inch	M inch	H inch	L1 inch	LR inch	SL inch	WB inch	WL inch	Refrigerant		Hot Gas	Drain	
										in NPS	out NPS	in NPS	NPT	
090.1C/44-	304 1/2	89 1/4	60 5/8	50 1/4	67 1/2	22 1/4	57 1/4	23 1/2	47 1/4	1	3	1	2x2	5,282
100.1B/44-	304 1/2	91 7/8	72 1/2	62	67 1/2	22 1/4	57 1/4	27	46 1/8	3/4	2 1/2	1 1/4	2x2	5,686
100.1C/44-	304 1/2	91 7/8	72 1/2	62	67 1/2	22 1/4	57 1/4	27	46 1/8	1 1/4	3	1 1/4	2x2	5,961
100.1D/44-	304 1/2	91 7/8	72 1/2	62	67 1/2	22 1/4	57 1/4	27	46 1/8	1 1/4	4	1 1/4	2x2	6,532
125.1C/44-	335 1/2	91 1/2	84 1/4	73 3/4	75 1/4	22 1/4	57 1/4	30 1/4	62	1 1/4	4	1 1/4	2x2	6,823
125.1D/44-	335 1/2	91 1/2	84 1/4	73 3/4	75 1/4	22 1/4	57 1/4	30 1/4	62	1 1/4	4	1 1/2	2x2	7,562
125.1E/44-	335 1/2	91 1/2	84 1/4	73 3/4	75 1/4	22 1/4	57 1/4	30 1/4	62	1 1/2	5	2	2x2	8,307
125.1F/44-	335 1/2	91 1/2	84 1/4	73 3/4	75 1/4	22 1/4	57 1/4	30 1/4	62	1 1/2	5	2	2x2	9,070
090.1C/47-	304 1/2	89 1/4	60 5/8	50 1/4	67 1/2	22 1/4	57 1/4	23 1/2	47 1/4	1	3	1	2x2	4,888
090.1D/47-	304 1/2	89 1/4	60 5/8	50 1/4	67 1/2	22 1/4	57 1/4	23 1/2	47 1/4	1	4	1 1/4	2x2	5,205
100.1C/47-	304 1/2	91 7/8	72 1/2	62	67 1/2	22 1/4	57 1/4	27	46 1/8	1	3	1 1/4	2x2	5,467
100.1D/47-	304 1/2	91 7/8	72 1/2	62	67 1/2	22 1/4	57 1/4	27	46 1/8	1 1/4	4	1 1/4	2x2	5,877
100.1E/47-	304 1/2	91 7/8	72 1/2	62	67 1/2	22 1/4	57 1/4	27	46 1/8	1 1/4	4	1 1/2	2x2	6,270
125.1C/47-	335 1/2	91 1/2	84 1/4	73 3/4	75 1/4	22 1/4	57 1/4	30 1/4	62	1 1/4	4	1 1/4	2x2	6,155
125.1D/47-	335 1/2	91 1/2	84 1/4	73 3/4	75 1/4	22 1/4	57 1/4	30 1/4	62	1 1/4	4	1 1/2	2x2	6,676
125.1E/47-	335 1/2	91 1/2	84 1/4	73 3/4	75 1/4	22 1/4	57 1/4	30 1/4	62	1 1/2	5	2	2x2	7,220
125.1F/47-	335 1/2	91 1/2	84 1/4	73 3/4	75 1/4	22 1/4	57 1/4	30 1/4	62	1 1/2	5	2	2x2	7,756
090.1D/410-	304 1/2	89 1/4	60 5/8	50 1/4	67 1/2	22 1/4	57 1/4	23 1/2	47 1/4	1	3	1 1/4	2x2	5,183
090.1E/410-	304 1/2	89 1/4	60 5/8	50 1/4	67 1/2	22 1/4	57 1/4	23 1/2	47 1/4	1	3	1 1/4	2x2	5,500
100.1C/410-	304 1/2	91 7/8	72 1/2	62	67 1/2	22 1/4	57 1/4	27	46 1/8	3/4	2 1/2	1 1/4	2x2	5,454
100.1D/410-	304 1/2	91 7/8	72 1/2	62	67 1/2	22 1/4	57 1/4	27	46 1/8	1	3	1 1/4	2x2	5,849
100.1E/410-	304 1/2	91 7/8	72 1/2	62	67 1/2	22 1/4	57 1/4	27	46 1/8	1 1/4	4	1 1/2	2x2	6,248
125.1C/410-	335 1/2	91 1/2	84 1/4	73 3/4	75 1/4	22 1/4	57 1/4	30 1/4	62	1 1/4	4	1 1/4	2x2	6,138
125.1D/410-	335 1/2	91 1/2	84 1/4	73 3/4	75 1/4	22 1/4	57 1/4	30 1/4	62	1 1/4	4	1 1/2	2	6,601
125.1E/410-	335 1/2	91 1/2	84 1/4	73 3/4	75 1/4	22 1/4	57 1/4	30 1/4	62	1 1/2	5	2	2	7,191
125.1F/410-	335 1/2	91 1/2	84 1/4	73 3/4	75 1/4	22 1/4	57 1/4	30 1/4	62	1 1/4	5	2	2	7,721

DRAWINGS FOR ALL MODELS

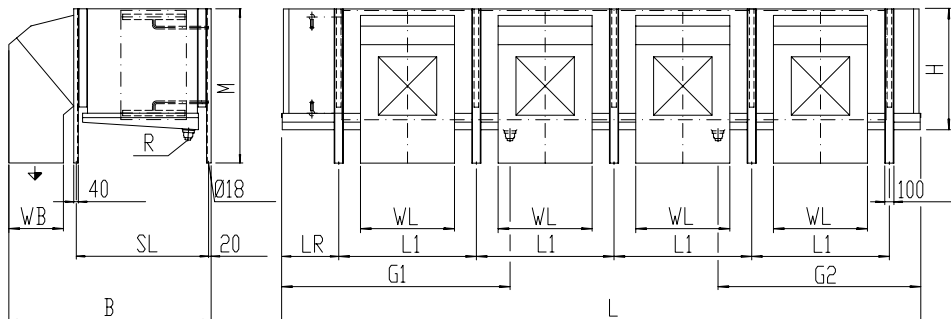

Options for Fan Discharge

> > LOW VELOCITY



DRAWINGS FOR ALL MODELS

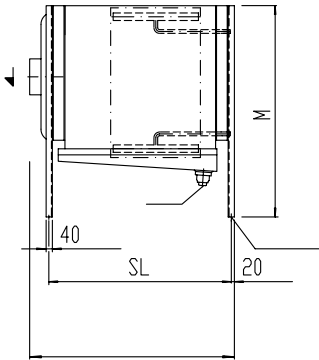

0° ANGLE

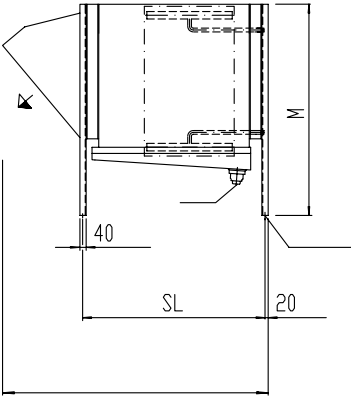

45° ANGLE

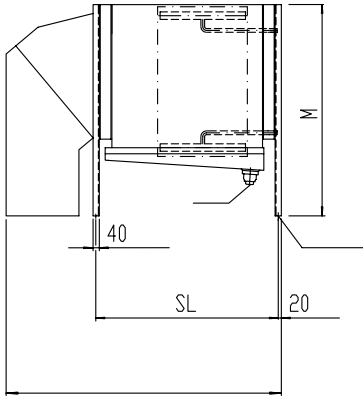

90° ANGLE

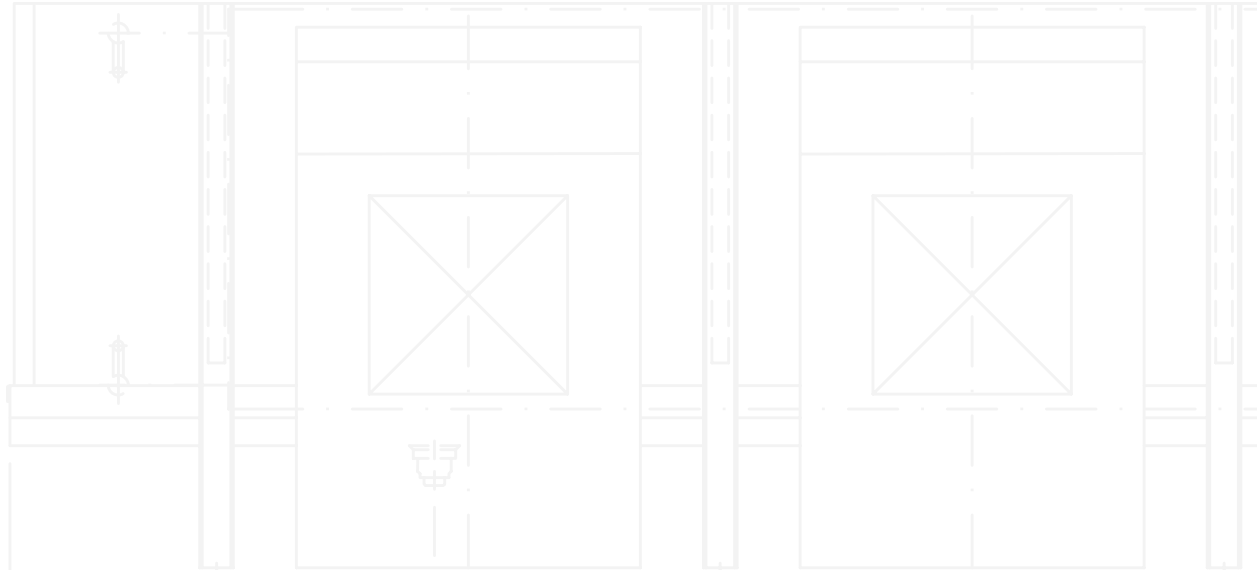

Form 610.30-SED1 (JAN 8)
Supersedes: Nothing (New Information)
Subject to change without notice
Printed in USA I WAY 1M 108 .20
© 2008 Johnson Controls Inc. - ALL RIGHTS RESERVED



FRICK
100 CV Avenue
Waynesboro, PA 17268 USA
Phone: 717-762-2121
FAX: 717-762-1305