

K Series

Motor Graders



Engine	120K		12K		140K		160K	
Engine Model	Cat® C7 ACERT™		Cat C7 ACERT		Cat C7 ACERT		Cat C7 ACERT	
Base Power (1st gear) – Net	93 kW	125 hp	108 kW	145 hp	128 kW	171 hp	139 kW	186 hp
Base Power (1st gear) – Net (Metric)	127 hp		147 hp		174 hp		189 hp	
Weights – Typically Equipped								
Gross Vehicle Weight	13 843 kg	30,519 lb	16 710 kg	36,839 lb	17 510 kg	38,603 lb	18 275 kg	40,289 lb
Gross Vehicle Weight – Maximum								
Gross Vehicle Weight	17 000 kg	37,478 lb	22 870 kg	50,420 lb	22 870 kg	50,420 lb	22 870 kg	50,420 lb
Moldboard								
Blade Width	3.7 m	12 ft	3.7 m	12 ft	3.7 m	12 ft	4.3 m	14 ft

K Series Features

Cat C7 Engine

Optimum power and fuel efficiency, combined with Power Management and Electronic Throttle Control, assure maximum productivity.

Power Train

The Power Shift transmission features direct drive and electronic control for smooth, powerful shifts at any speed.

Balanced Hydraulics

Proportional hydraulic flow gives operators outstanding "feel" and predictable movements.

Machine Safety

Cat machines are designed with features to help protect the operator and others around the job site.

Serviceability

Grouped service points make daily maintenance easier and faster, while enhanced diagnostics and monitoring help reduce downtime.



Contents

Power Train.....	3
Cat C7 Engine.....	3
Hydraulics	4
Structures/Drawbar-Circle-Moldboard	5
Work Tools and Attachments.....	6
Operator Station.....	7
Integrated Technologies.....	8
Safety	9
Complete Customer Support.....	10
Sustainability	10
Serviceability.....	11
120K Motor Grader Specifications.....	12
12K Motor Grader Specifications.....	15
140K Motor Grader Specifications.....	18
160K Motor Grader Specifications.....	21
K Series Specifications.....	24
K Series Standard Equipment.....	25
K Series Optional Equipment	26
Notes.....	27

The K Series Motor Grader is the machine you can count on when you need to get work done. Cat motor graders help you make the most of your investment by delivering maximum productivity and durability. The Cat C7 engine, direct-drive power shift transmission and load sensing hydraulics work together to ensure the power and precision you need to work in demanding conditions. And Cat motor graders are backed by the world-class Cat dealer network to keep you up and running.

Power Train

Reliable performance

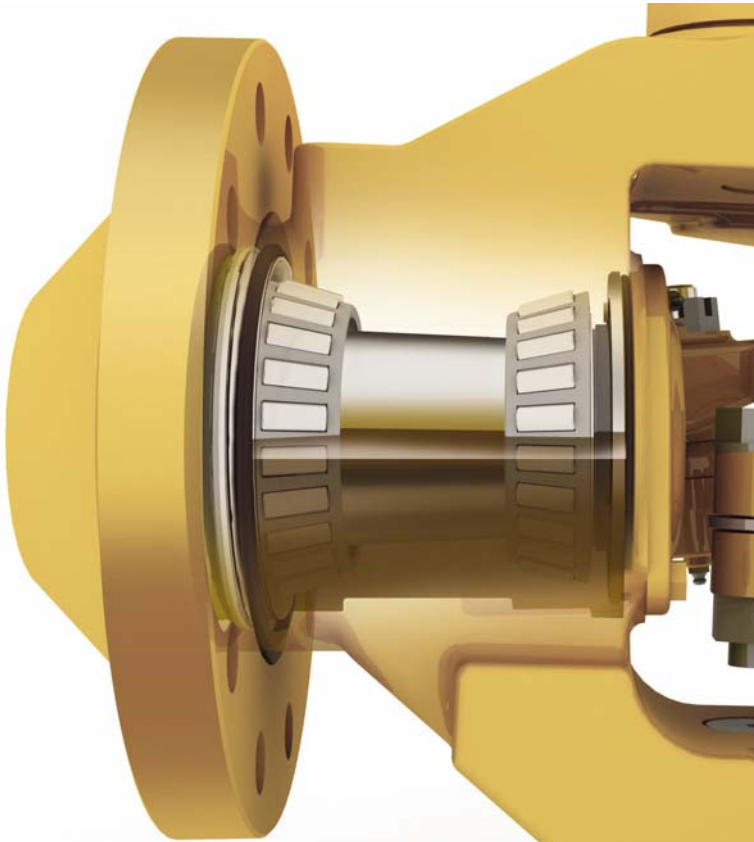

Smooth Shifting Transmission

- Full Electronic Clutch Pressure Control ensures smooth shifting and directional changes.
- Shift Torque Management helps to smooth gear changes without the use of the inching pedal, helping the operator to remain focused on the task at hand.
- Load Compensation ensures consistent shift quality regardless of blade or machine load.
- Optional Autoshift automatically shifts the transmission at optimal points for easier operation.

Oil Disc Brakes – Completely Sealed, Adjustment Free

Oil-bathed, air actuated and spring-released, located at each tandem wheel to eliminate power train braking loads and to reduce service time. The large brake surface area provides dependable braking capability and extended life before rebuild.

Front Axle with Cat Live Spindle Design

Cat sealed spindle keeps the bearings free from contaminants and lubricated in a lightweight oil to reduce owning and operating costs. A larger tapered roller bearing is outboard where the load is greater, extending bearing life.

Cat C7 Engine

Maximum power and efficiency

Power Management

The Cat C7 engine with ACERT Technology uses electronic control, precision fuel delivery and refined air management to provide outstanding performance and lower emissions.

Variable Horse Power (VHP) is standard to provide more power in the higher gears. The Electronic Throttle Control provides easier, more precise and consistent throttle operation. Engine Over-Speed Protection prevents downshifting until an acceptable safe travel speed has been established.



Hydraulics

Balanced hydraulics deliver consistent, precise and responsive control



Balanced Flow, Independent Oil Supply

Hydraulic flow is proportioned to ensure all implements operate simultaneously. Independent oil supply prevents cross-contamination and provides proper oil cooling, which means less heat build-up and extended component life.

Implement Control Valves

Provide outstanding operator “feel” and predictable system response for unmatched implement control. To help maintain exact blade settings, lock valves are built into all control valves. Line relief valves are also incorporated into selected control valves to protect the cylinders from over pressurization.

Load-Sensing Hydraulics

A load sensing variable displacement pump and advanced hydraulic valves provide superior implement control and better machine performance. Continuously matching hydraulic flow and pressure to power demands creates less heat and reduces power consumption.

Consistent and Predictable Movement

The hydraulic system valves are specifically designed for each hydraulic function on the motor grader. They compensate for differences in flow requirements, based on cylinder size and the difference in surface volume between the rod end (blue) and barrel end (red) of the cylinder. The result is predictable, consistent hydraulic speeds whether extending or retracting the cylinder.





Structures/Drawbar-Circle-Moldboard

Designed for strength and durability

Frame Structure – Provides Consistency and Strength

Front frame is a continuous top and bottom plate construction. Flanged box section design removes welds from high stress areas, improving reliability and durability. The rear frame structure has two box section channels with fully welded differential case for a solid working platform. An integrated bumper ties the rear frame together into a cohesive unit to handle high stress loads.

Drawbar, Circle and Moldboard

The K Series drawbar is designed for high strength and optimum durability for any application.

The circle stands up to high stress loads. Raised wear surfaces prevent circle teeth wear against the drawbar. The 64 uniformly spaced circle teeth are flame cut and heat induction hardened to resist wear, and the circle is secured to the drawbar by four (120K) or six (12K, 140K, 160K) support shoes for maximum support.

The moldboard provides optimal curvature and large throat clearance that helps move all soil types quickly and efficiently. These features deliver excellent load distribution and minimal material buildup in the circle area while allowing large blade loads to roll freely.

Blade Lift Accumulators

This optional feature uses accumulators to help absorb impact loads to the moldboard by allowing vertical blade travel. Blade lift accumulators reduce unnecessary wear and help to avoid unintended machine movement for increased operator safety.

Work Tools and Attachments

Allows expansion of machine versatility, utilization, and performance



Moldboard Options

Standard moldboard length is 3.7 m (12 ft) (120K, 12K, 140K) and 4.3 m (14 ft) (160K), with an optional 4.3 m (14 ft) (12K, 140K only) moldboard available from the factory. Moldboard extensions are available to increase moldboard surface area and extend reach capability.

Ground Engaging Tools

A wide variety of cutting edges and end bits are available, all designed for maximum service life and productivity.

Rear Ripper/Scarifier

The K Series optional ripper/scarifier is made to penetrate tough material fast and rip thoroughly for easier material movement with the moldboard. The ripper includes three shanks with the ability to add two more if needed. Nine scarifier shanks can also be added for additional versatility (12K, 140K, 160K only).

Front Mounted Groups

A front mounted push plate/counterweight or front blade can be ordered.

Mid-Mount Scarifier

Positioned between the front axle and the circle to break up tough material that the blade can then move, all in a single pass. The V-type scarifier can accommodate up to 11 teeth.

Snow Removal Work Tools

Includes snow wings, angle blades, and V-plows. Multiple mounting options are available, increasing machine versatility. (Availability may differ by region.)



1) 120K ripper 2) 12K,140K,160K ripper



Operator Station

Caterpillar sets the standard for comfort, convenience and visibility

Designed for Productivity

K Series cabs are designed to keep operators comfortable, relaxed and productive. Features like low effort pedals and controls, adjustable implement controls and adjustable steering wheel angle help make work easier on the operator. A clear view to the moldboard heel and tandem tires enhance productivity and safe operation. Rocker switches and transmission shifter are backlit for night time operation.

In-dash Instrument Cluster

The instrument panel, with easy-to read, high-visibility gauges and warning lamps, places vital machine information and diagnostic capability in easy view of the operator. The dash includes an engine coolant temperature gauge, an articulation gauge, voltage gauge and fuel level gauge. Service brake air pressure gauges are also standard. Speedometer and tachometer are optional. All major systems are monitored by warning lights.

Additional Cab Features

Additional cab features include storage area, an adjustable control console and coat hook. Optional offerings include power port, air conditioner/heater, suspension seat, defroster fan, sun shade, backup lights, Product Link™ ready, and AccuGrade™ System ready.

NOTE: Some attachments are not available in all regions.

Integrated Technologies

Solutions to make work easier and more efficient



Cat AccuGrade

AccuGrade uses positioning and guidance technologies, machine sensors, and automatic blade control to help operators get to grade faster, easier and more efficiently. Digital design plans, real-time cut/fill data, and in-cab guidance give operators detailed information to work more confidently and achieve greater accuracy, in fewer passes, using less material.

Operators can stay on grade and improve productivity and accuracy by nearly 50 percent over conventional methods. Grade stakes and checkers are minimized, making the work site safe, efficient, and cost effective. AccuGrade technologies include Cross Slope, Sonic, Laser, GPS, and/or Universal Total Station (UTS).

AccuGrade Attachment Ready Option (ARO)

K Series machines can be equipped with the AccuGrade ARO. It can be ordered as a factory or dealer installed option.

The attachment option includes built-in mounting points and internal wiring, making installation of the AccuGrade grade control system faster and easier.

Cat Product Link

Product Link helps take the guesswork out of equipment management with remote monitoring capabilities for your machine or your entire fleet. Track asset location, hours, fuel usage, diagnostic codes, idle time and more through the secure VisionLink™ user interface. Knowing where your equipment is, what it's doing and how it's performing enables you or your Cat dealer to manage your fleet in real-time so you can maximize efficiency, improve productivity, and lower operating costs.





Safety

Designed with safety in mind

ROPS/FOPS Cab Offers Low Sound and Vibration Levels

The operator sound pressure level for the cab offered by Caterpillar, when properly installed, maintained and tested with the doors closed, meets or exceeds requirements set forth in ISO 6394:2008. The quiet environment helps improve operator working conditions.

Brake Systems and Machine Protection

Brakes located at each tandem wheel offer the largest total brake surface area in the industry, delivering dependable stopping power and longer brake life. Standard circle drive slip clutch protects the drawbar, circle and moldboard from shock loads when the blade encounters an immovable object. Blade lift accumulators help absorb impact loads to the moldboard by allowing vertical blade travel.

Electrical Disconnect Switch and Engine Shutoff Switch

Disconnect switch provides ground-level lockout of the electrical system to prevent inadvertent machine starts. Engine shutoff allows anyone nearby to shut the machine down in case of an emergency.

Additional Safety Features

Laminated glass on the front windows and lockable doors to reduce theft and vandalism are available with the optional cab. Brake lights, conveniently located grab rails, back up lights and alarm also help ensure a safe work environment.

Complete Customer Support

When uptime counts



Renowned Cat Dealer Support

From helping you choose the right machine to financing and ongoing support, your Cat dealer provides the best in sales and service.

Manage your costs with preventive maintenance programs like S•O•SSM fluids analysis, coolant sampling and guaranteed maintenance contracts.

Stay productive with best-in-class parts availability. Your Cat dealer can help you boost your profits with operator training.

And when it's time for component replacement, your Cat dealer can help you save even more. Genuine Cat Remanufactured parts carry the same warranty and reliability as new products at savings of 40 to 70 percent for power train and hydraulic components.

Sustainability

Thinking generations ahead

- Integrated machine systems and technologies improve productivity for greater accuracy, lower fuel use and reduced machine wear.
- Replaceable wear parts save maintenance time and cost, and extend major component life.
- Ecology drains help make draining fluids more convenient and help prevent spills.
- Major components are built to be rebuilt, eliminating waste and saving customers money by giving the machine and/or major components a second – and even third life.
- A variety of safety features help safeguard operators and others on the job site.



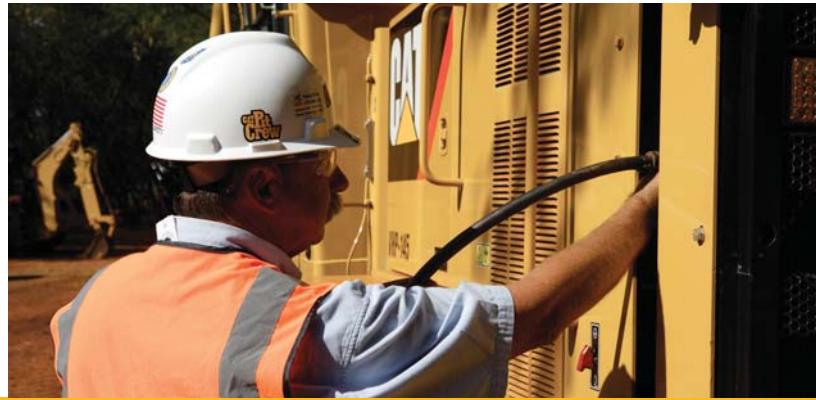

Serviceability

Convenient service points make routine maintenance quick and easy

Grouped Service Points on the left side to help ensure proper maintenance

Easy access to service areas speeds up maintenance and ensures that routine service is performed on time. Ecology drains shorten service times and help prevent spills. Radiator cleanout access gives the operator the ability to clear away debris and other materials that build up around the radiator.

Extended Service Intervals Reduce Downtime, Operating Cost

• 500 hour engine oil changes • 4,000 hour hydraulic oil changes • 12,000 hour engine coolant changes

Diagnostics and Machine Monitoring

The dash cluster panel provides enhanced machine information and diagnostic capability, which allows faster servicing of the transmission and engine.

O-Ring Face Seals

O-Ring face seals create a reliable connection and are used in all hydraulic circuits to minimize the possibility of oil leaks.

Separate Wiring Harnesses

Modular harness design provides simple disconnects for major machine repairs or rebuilds which reduces machine downtime.

Cat Electronic Technician

Cat Electronic Technician is a two-way communication tool that gives service technicians easy access to stored diagnostic data, reducing machine downtime and lowering operating costs.

120K Motor Grader Specifications

Engine		
Engine Model	Cat C7 ACERT	
Base Power (1st gear) – Net	93 kW	125 hp
Base Power (1st gear) – Net (Metric)		127 hp
VHP Range – Net	93-108 kW	125-145 hp
VHP – gears		
1-2 Net	93 kW	125 hp
3 Net	101 kW	135 hp
4-8 Net	108 kW	145 hp
1-2 Gross	103 kW	138 hp
3 Gross	110 kW	148 hp
4-8 Gross	118 kW	158 hp
Displacement	7.2 L	439 in ³
Bore	105 mm	4.1 in
Stroke	127 mm	5 in
Torque Rise	50%	
Maximum Torque Net	774 N·m	571 ft-lb
Speed @ rated power	2,000 rpm	
Number of cylinders	6	
Derating altitude	3048 m	10,000 ft
Fan Speed Maximum	1,575 rpm	
High Ambient Capability	50° C	122° F

- Net power is tested per ISO 9249, SAE J1349, and EEC 80/1269 standards in effect at the time of manufacture.
- Net power advertised is the power available at rated speed of 2,000 rpm, measured at the flywheel when engine is equipped with fan, air cleaner, muffler and alternator.
- Maximum torque measured at 1,000 rpm in gears 4-8.

Power Train		
Forward/Reverse Gears	8 forward/6 reverse	
Transmission	Direct drive, Powershift	
Brakes		
Service	Air actuated, multiple oil-disc	
Service, surface area	18 606 cm ²	2,884 in ²
Parking	Air actuated, multiple oil-disc	
Secondary	Dual Circuit	

- Brakes meet the following standards: SAE J/ISO 3450 JAN 98.

Operating Specifications		
Top Speed		
forward	47.5 km/h	29.5 mph
reverse	37.5 km/h	23.3 mph
Turning Radius, outside front tires	7.3 m	23 ft 11 in
Steering Range – left/right	47.5 Degrees	
Articulation Angle – left/right	20 Degrees	
Forward		
1st	4.1 km/h	2.5 mph
2nd	5.5 km/h	3.4 mph
3rd	8.0 km/h	5.0 mph
4th	11.1 km/h	6.9 mph
5th	17.5 km/h	10.8 mph
6th	23.7 km/h	14.8 mph
7th	32.7 km/h	20.3 mph
8th	47.5 km/h	29.5 mph
Reverse		
1st	3.2 km/h	2.0 mph
2nd	6.0 km/h	3.7 mph
3rd	8.7 km/h	5.4 mph
4th	13.8 km/h	8.6 mph
5th	25.8 km/h	16.0 mph
6th	37.5 km/h	23.3 mph

- Maximum travel speeds calculated at high idle on standard machine configuration with 14.00-24 12PR (G-2) tires.

Hydraulic System		
Circuit Type	Load Sensing, Closed Center, PPC	
Pump Type	Variable Piston	
Pump Output Standard Pump	159.1 L/min	42 gal/min
Optional High Output Pump	210.5 L/min	55.6 gal/min
Maximum System Pressure	25 500 kPa	3,699 psi
Standby Pressure	3600 kPa	522.1 psi
Reservoir Tank Capacity	24.5 L	6.5 gal

- Pump output measured at 2,150 rpm

Moldboard		
Blade Width	3.7 m	12 ft
Moldboard		
height	610 mm	24 in
thickness	22 mm	0.9 in
Arc Radius	413 mm	16.3 in
Throat Clearance	58 mm	2.3 in
Cutting Edge		
width	152 mm	6 in
thickness	16 mm	0.6 in
End Bit		
width	152 mm	6 in
thickness	16 mm	0.6 in
Blade Pull		
base GVW	8112 kg	17,884 lb
maximum GVW	10 623 kg	23,420 lb
Down Pressure		
base GVW	5594 kg	12,332 lb
maximum GVW	9317 kg	20,540 lb

- Blade Pull calculated at 0.9 traction coefficient, which is equal to ideal no-slip conditions, and Gross Vehicle Weight (GVW).

120K Motor Grader Specifications

Blade Range

Circle Centershift		
right	656 mm	25.8 in
left	658 mm	25.8 in
Moldboard Sideshift		
right	663 mm	26 in
left	512 mm	20.2 in
Maximum Blade Position Angle	90 Degrees	
Blade Tip Range		
forward	40 Degrees	
backward	5 Degrees	
Maximum shoulder reach outside of tires		
right	1928 mm	75.9 in
left	1764 mm	69.4 in
Maximum lift above ground	410 mm	16.1 in
Maximum depth of cut	775 mm	30.5 in

Ripper

Ripping depth – maximum	262 mm	10.3 in
Ripper shank holders, quantity	5	
Ripper shank holder spacing	533 mm	21 in
Penetration force	4083 kg	9,001 lb
Pryout force	2108 kg	4,648 lb
Machine length increase, beam raised	1058 mm	41.7 in

Scarifier

Mid, V-Type:		
Working width	1184 mm	46.6 in
Scarifying depth, maximum	229 mm	9 in
Scarifier shank holders quantity	11	
Scarifier shank holder spacing	116 mm	4.6 in

- The mid-mount scarifier is positioned under the drawbar between the moldboard and front axle.

Frame

Circle		
diameter	1530 mm	60.2 in
blade beam thickness	30 mm	1.2 in
Drawbar		
height	127 mm	5 in
width	76.2 mm	3 in
Front axle		
height to center	615 mm	24.2 in
wheel lean, left/right	18 Degrees	
total oscillation per side	32 Degrees	
Front-top/bottom plate		
width	280 mm	11 in
thickness	22 mm	0.9 in
Front-side plates		
width	236 mm	9.3 in
thickness	10 mm	0.4 in
Front-linear weights		
minimum	134 kg/m	90 lb/ft
maximum	172 kg/m	115 lb/ft
Front-section modulus		
minimum	1619 cm ³	99 in ³
maximum	3681 cm ³	225 in ³

Tandems

Height	438 mm	17.24 in
Width	172 mm	6.77 in
Sidewall thickness		
inner	1 mm	1 in
outer	16 mm	0.63 in
Drive chain pitch	44.5 mm	1.75 in
Wheel axle spacing	1510 mm	59.45 in
Tandem oscillation		
front up	15 Degrees	
front down	25 Degrees	

120K Motor Grader Specifications

Service Refill

Fuel Capacity	305 L	80.6 gal
Cooling system	40 L	10.6 gal
Engine Oil	18 L	4.8 gal
Transmission/ Differential/ Final Drives	48 L	12.7 gal
Tandem housing (each)	49 L	12.9 gal
Front wheel spindle bearing housing	0.5 L	0.1 gal
Circle drive housing	7 L	1.9 gal

Weights

Gross Vehicle Weight – Base		
total	12 133 kg	26,749 lb
front axle	3120 kg	6,878 lb
rear axle	9013 kg	19,871 lb
Gross Vehicle Weight – Typically Equipped		
total	13 843 kg	30,519 lb
front axle	3970 kg	8,751 lb
rear axle	9873 kg	21,768 lb
Gross Vehicle Weight – Maximum		
total	17 000 kg	37,478 lb
front axle	5197 kg	11,456 lb
rear axle	11 803 kg	26,022 lb

- Base weight calculated on standard machine configuration with 13.00-24 12PR (G-2) tires, full fuel tank, coolant, lubricants and operator.
- Typical operating weight calculated on standard machine configuration with Cab High Profile ROPS, 14.00-24 12PR (G-2) tires, mid mount scarifier, full fuel tank, coolant, lubricants and operator.
- Maximum Vehicle Weight includes all compatible attachments with Cab High Profile ROPS, 14.00-24 12PR (G-2) tires, full fuel tank, coolant, lubricants and operator.

Standards

ROPS/FOPS	ISO 3471:1994/ ISO 3449:2005
Steering	ISO 5010:2007
Brakes	ISO 3450:1996
Sound	ISO 6394:2008 ISO 6396:2008

- These standards are met when the machine is equipped with a cab.
- The static operator sound pressure level is 77 dB(A) when “ISO 6394:2008” is used to measure the value for an enclosed cab. The measurement was conducted with the cab doors and the cab windows closed. The cab was properly installed and maintained.

12K Motor Grader Specifications

Engine

Engine Model	Cat® C7 ACERT™	
Base Power (1st gear) – Net	108 kW	145 hp
Base Power (1st gear) – Net (Metric)		147 hp
VHP Range – Net	108-123 kW	145-165 hp
VHP – gears		
1-2 Net	108 kW	145 hp
3 Net	116 kW	156 hp
4-8 Net	123 kW	165 hp
1-2 Gross	118 kW	158 hp
3 Gross	125 kW	168 hp
4-8 Gross	133 kW	178 hp
Displacement	7.2 L	439 in ³
Bore	105 mm	4.1 in
Stroke	127 mm	5 in
Torque Rise	50%	
Maximum Torque Net	881 N·m	650 ft·lb
Speed @ rated power	2,000 rpm	
Number of cylinders	6	
Derating altitude	3048 m	10,000 ft
Fan Speed Maximum	1,575 rpm	
High Ambient Capability	50° C	122° F

- Net power is tested per ISO 9249, SAE J1349, and EEC 80/1269 standards in effect at the time of manufacture.
- Net power advertised is the power available at rated speed of 2,000 rpm, measured at the flywheel when engine is equipped with fan, air cleaner, muffler and alternator.
- Maximum torque measured at 1,000 rpm in gears 4-8.

Power Train

Forward/Reverse Gears	8 forward/6 reverse	
Transmission	Direct Drive, powershift	
Brakes		
Service	Air actuated, multiple oil-disc	
Service, surface area	23 948 cm ² 3,712 in ²	
Parking	Air actuated, multiple oil-disc	
Secondary	Dual circuit	

- Brakes meet the following standards: SAE J/ISO 3450 JAN 98.

Operating Specifications

Top Speed		
forward	46.6 km/h	29.0 mph
reverse	36.8 km/h	22.9 mph
Turning Radius, outside front tires	7.5 m	24 ft 7 in
Steering Range – left/right	47.5 Degrees	
Articulation Angle – left/right	20 Degrees	
Forward		
1st	4.0 km/h	2.5 mph
2nd	5.4 km/h	3.4 mph
3rd	7.9 km/h	4.9 mph
4th	10.9 km/h	6.8 mph
5th	17.1 km/h	10.6 mph
6th	23.3 km/h	14.5 mph
7th	32.0 km/h	19.9 mph
8th	46.6 km/h	29.0 mph
Reverse		
1st	3.2 km/h	2.0 mph
2nd	5.9 km/h	3.7 mph
3rd	8.6 km/h	5.3 mph
4th	13.5 km/h	8.4 mph
5th	25.3 km/h	15.7 mph
6th	36.8 km/h	22.9 mph

- Maximum travel speeds calculated at high idle on standard machine configuration with 14.00-24 12PR (G-2) tires.

Hydraulic System

Circuit Type	Load Sensing, Closed Center, PPPC	
Pump Type	Variable piston	
Pump Output Standard Pump	159.1 L/min	42 gal/min
Optional High Output Pump	210.5 L/min	55.6 gal/min
Maximum System Pressure	25 500 kPa	3,698.5 psi
Standby Pressure	3600 kPa	522.1 psi
Reservoir Tank Capacity	55 L	14 gal

- Pump output measured @ 2,150 rpm.

Moldboard

Blade Width	3.7 m	12 ft
Moldboard		
height	610 mm	24 in
thickness	22 mm	0.9 in
Arc Radius	413 mm	16.3 in
Throat Clearance	120 mm	4.7 in
Cutting Edge		
width	152 mm	6 in
thickness	16 mm	0.6 in
End Bit		
width	152 mm	6 in
thickness	16 mm	0.6 in
Blade Pull		
base GVW	8838 kg	19,485 lb
maximum GVW	13 379 kg	29,496 lb
Down Pressure		
base GVW	6405 kg	14,121 lb
maximum GVW	13 964 kg	30,785 lb

- Blade Pull calculated at 0.9 traction coefficient, which is equal to ideal no-slip conditions, and Gross Vehicle Weight (GVW).

12K Motor Grader Specifications

Blade Range

Circle Centershift		
right	728 mm	28.7 in
left	752 mm	29.6 in
Moldboard Sideshift		
right	663 mm	26.1 in
left	512 mm	20.2 in
Maximum Blade Position Angle	90 Degrees	
Blade Tip Range		
forward	40 Degrees	
backward	5 Degrees	
Maximum shoulder reach outside of tires		
right	1809 mm	71.2 in
left	1859 mm	73.2 in
Maximum lift above ground	480 mm	18.9 in
Maximum depth of cut	735 mm	28.9 in

Ripper

Ripping depth – maximum	462 mm	18.2 in
Ripper shank holders, quantity	5	
Ripper shank holder spacing	533 mm	21 in
Penetration force	8444 kg	18,615 lb
Pryout force	10 353 kg	22,825 lb
Machine length increase, beam raised	970 mm	38.2 in
Scarifier shank holder quantity	9	

Scarifier

Mid, V-Type		
Working width	1184 mm	46.6 in
Scarifying depth, maximum	292 mm	11.5 in
Scarifier shank holders quantity	11	
Scarifier shank holder spacing	116 mm	4.6 in
Rear		
Working width	2300 mm	90.6 in
Scarifying depth, maximum	411 mm	16.2 in
Scarifier shank holders quantity	9	
Scarifier shank holder spacing	267 mm	10.5 in

• The mid-mount scarifier is positioned under the drawbar between the moldboard and front axle.

Frame

Circle		
diameter	1530 mm	60.2 in
blade beam thickness	30 mm	1.2 in
Drawbar		
height	127 mm	5 in
width	76 mm	3 in
Front axle		
height to center	615 mm	24.2 in
wheel lean, left/right	18 Degrees	
total oscillation per side	32 Degrees	
Front-top/bottom plate		
width	305 mm	12 in
thickness	25 mm	1 in
Front-side plates		
width	242 mm	9.5 in
thickness	12 mm	0.5 in
Front-linear weights		
minimum	165 kg/m	112 lb/ft
maximum	213 kg/m	144 lb/ft
Front-section modulus		
minimum	2083 cm ³	127 in ³
maximum	4785 cm ³	291 in ³
Tandems		
Height	506 mm	19.9 in
Width	201 mm	7.9 in
Sidewall thickness		
inner	16 mm	0.6 in
outer	18 mm	0.7 in
Drive chain pitch	51 mm	2 in
Wheel axle spacing	1522 mm	59.9 in
Tandem oscillation		
front up	15 Degrees	
front down	25 Degrees	

12K Motor Grader Specifications

Service Refill

Fuel Capacity	305 L	80.6 gal
Cooling system	40 L	10.6 gal
Engine Oil	18 L	4.8 gal
Transmission/ Differential/ Final Drives	60 L	15.9 gal
Tandem housing (each)	64 L	16.9 gal
Front wheel spindle bearing housing	0.5 L	0.1 gal
Circle drive housing	7 L	1.9 gal

Weights

Gross Vehicle Weight – Base		
total	13 492 kg	29,744 lb
front axle	3672 kg	8,095 lb
rear axle	9820 kg	21,650 lb
Gross Vehicle Weight – Typically Equipped		
total	16 710 kg	36,839 lb
front axle	4553 kg	10,038 lb
rear axle	12 157 kg	26,802 lb
Gross Vehicle Weight – Maximum		
total	22 870 kg	50,420 lb
front axle	8005 kg	17,647 lb
rear axle	14 866 kg	32,773 lb

- Base weight calculated on standard machine configuration with 13.00-24 12PR (G-2) tires, full fuel tank, coolant, lubricants and operator.
- Typical operating weight calculated on standard machine configuration with Cab High Profile ROPS, rear ripper, push block, 14.00-24 12PR (G-2) tires, full fuel tank, coolant, lubricants and operator.
- Maximum Vehicle Weight includes all compatible attachments with Cab High Profile ROPS, 13.00-24 12PR (G-2) tires, full fuel tank, coolant, lubricants and operator.

Standards

ROPS/FOPS	ISO 3471:1994/ ISO 3449:2005
Steering	ISO 5010:2007
Brakes	ISO 3450:1996
Sound	ISO 6394:2008 ISO 6396:2008

- These standards are met when the machine is equipped with a cab.
- The static operator sound pressure level is 77 dB(A) when “ISO 6394:2008” is used to measure the value for an enclosed cab. The measurement was conducted with the cab doors and the cab windows closed. The cab was properly installed and maintained.

140K Motor Grader Specifications

Engine		
Engine Model	Cat® C7 ACERT™	
Base Power (1st gear) – Net	128 kW	171 hp
Base Power (1st gear) – Net (Metric)		174 hp
VHP Range – Net	128-143 kW	171-191 hp
VHP – gears		
1-2 Net	128 kW	171 hp
3 Net	135 kW	181 hp
4-8 Net	143 kW	191 hp
1-2 Gross	140 kW	188 hp
3 Gross	147 kW	198 hp
4-8 Gross	155 kW	208 hp
Displacement	7.2 L	439 in ³
Bore	105 mm	4.1 in
Stroke	127 mm	5 in
Torque Rise	46%	
Maximum Torque Net	996 N·m	735 lb ft
Speed @ rated power	2,000 rpm	
Number of cylinders	6	
Derating altitude	3048 m	10,000 ft
Fan Speed Maximum	1,925 rpm	
High Ambient Capability	50° C	122° F

- Net power is tested per ISO 9249, SAE J1349, and EEC 80/1269 standards in effect at the time of manufacture.
- Net power advertised is the power available at rated speed of 2,000 rpm, measured at the flywheel when engine is equipped with fan, air cleaner, muffler and alternator.
- Maximum torque measured at 1,000 rpm in gears 4-8.

Power Train		
Forward/Reverse Gears	8 forward/6 reverse	
Transmission	Direct drive, Power shift	
Brakes		
Service	Air actuated, multiple oil-disc	
Service, surface area	23 948 cm ² 3,712 in ²	
Parking	Air actuated, multiple oil-disc	
Secondary	Dual circuit	

- Brakes meet the following standards: SAE J/ISO 3450 JAN 98.

Operating Specifications		
Top Speed		
forward	47.3 km/h	29.4 mph
reverse	37.4 km/h	23.2 mph
Turning Radius, outside front tires	7.5 m	24 ft 9 in
Steering Range – left/right	47.5 Degrees	
Articulation Angle – left/right	20 Degrees	
Forward		
1st	4.1 km/h	2.5 mph
2nd	5.5 km/h	3.4 mph
3rd	8.0 km/h	5.0 mph
4th	11.0 km/h	6.9 mph
5th	17.4 km/h	10.8 mph
6th	23.6 km/h	14.7 mph
7th	32.5 km/h	20.2 mph
8th	47.3 km/h	29.4 mph
Reverse		
1st	3.2 km/h	2.0 mph
2nd	6.0 km/h	3.7 mph
3rd	8.7 km/h	5.4 mph
4th	13.7 km/h	8.5 mph
5th	25.7 km/h	16.0 mph
6th	37.4 km/h	23.2 mph

- Maximum travel speeds calculated at high idle on standard machine configuration with 17.50-25 12PR (G-2) tires.

Hydraulic System		
Circuit Type	Load Sensing, Closed Center, Proportional Priority Pressure Compensating System	
Pump Type	Variable Piston	
Pump Output Standard Pump	159.1 L/min	42 gal/min
Optional High Output Pump	210.5 L/min	55.6 gal/min
Maximum System Pressure	25 500 kPa	3,698.5 psi
Standby Pressure	3600 kPa	522.1 psi
Reservoir Tank Capacity	55 L	14.5 gal

• Pump output measured @ 2,150 rpm.

Moldboard		
Blade Width	3.7 m	12 ft
Moldboard		
height	610 mm	24 in
thickness	22 mm	0.9 in
Arc Radius	413 mm	16.3 in
Throat Clearance	120 mm	4.7 in
Cutting Edge		
width	152 mm	6 in
thickness	16 mm	0.6 in
End Bit		
width	152 mm	6 in
thickness	16 mm	0.6 in
Blade Pull		
base GVW	9108 kg	20,080 lb
maximum GVW	13 379 kg	29,496 lb
Down Pressure		
base GVW	7278 kg	16,044 lb
maximum GVW	13 963 kg	30,784 lb

- Blade Pull calculated at 0.9 traction coefficient, which is equal to ideal no-slip conditions, and Gross Vehicle Weight (GVW).

140K Motor Grader Specifications

Blade Range

Circle Centershift		
right	728 mm	28.7 in
left	752 mm	29.6 in
Moldboard Sideshift		
right	663 mm	26.1 in
left	512 mm	20.2 in
Maximum Blade Position Angle	90 Degrees	
Blade Tip Range		
forward	40 Degrees	
backward	5 Degrees	
Maximum shoulder reach outside of tires		
right	1978 mm	77.9 in
left	1896 mm	74.6 in
Maximum lift above ground	480 mm	18.9 in
Maximum depth of cut	735 mm	28.9 in

Ripper

Ripping depth – maximum	462 mm	18.2 in
Ripper shank holders, quantity	5	
Ripper shank holder spacing	533 mm	21 in
Penetration force	8694 kg	19,166 lb
Pryout force	11 673 kg	25,735 lb
Machine length increase, beam raised	970 mm	38.2 in
Scarifier shank holder quantity	9	

Scarifier

Mid, V-Type		
Working width	1184 mm	46.6 in
Scarifying depth, maximum	229 mm	9 in
Scarifier shank holders quantity	11	
Scarifier shank holder spacing	116 mm	4.6 in
Rear		
Working width	2300 mm	90.6 in
Scarifying depth, maximum	266 mm	10.5 in
Scarifier shank holders quantity	9	
Scarifier shank holder spacing	267 mm	10.5 in

- The mid-mount scarifier is positioned under the drawbar between the moldboard and front axle.

Frame

Circle		
diameter	1530 mm	60.2 in
blade beam thickness	35 mm	1.4 in
Drawbar		
height	127 mm	5 in
width	76.2 mm	3 in
Front axle		
height to center	628 mm	24.7 in
wheel lean, left/right	18 Degrees	
total oscillation	32 Degrees	
Front-top/bottom plate		
width	305 mm	12 in
thickness	25 mm	1 in
Front-side plates		
width	242 mm	9.5 in
thickness	12 mm	0.5 in
Front-linear weights		
minimum	165 kg/m	112 lb/ft
maximum	213 kg/m	144 lb/ft
Front-section modulus		
minimum	2083 cm ³	127 in ³
maximum	4785 cm ³	291 in ³
Tandems		
Height	506 mm	19.9 in
Width	201 mm	7.9 in
Sidewall thickness		
inner	16 mm	0.6 in
outer	18 mm	0.7 in
Drive chain pitch	51 mm	2 in
Wheel axle spacing	1522 mm	59.9 in
Tandem oscillation		
front up	15 Degrees	
front down	25 Degrees	

140K Motor Grader Specifications

Service Refill

Fuel Capacity	305 L	80.6 gal
Cooling system	40 L	10.6 gal
Engine Oil	18 L	4.8 gal
Transmission/ Differential/ Final Drives	60 L	15.9 gal
Tandem housing (each)	64 L	16.9 gal
Front wheel spindle bearing housing	0.5 L	0.1 gal
Circle drive housing	7 L	1.9 gal

Weights

Gross Vehicle Weight – Base		
total	14 292 kg	31,508 lb
front axle	4172 kg	9,197 lb
rear axle	10 120 kg	22,311 lb
Gross Vehicle Weight – Typically Equipped		
total	17 510 kg	38,603 lb
front axle	5053 kg	11,140 lb
rear axle	12 457 kg	27,463 lb
Gross Vehicle Weight – Maximum		
total	22 870 kg	50,420 lb
front axle	8005 kg	17,647 lb
rear axle	14 866 kg	32,773 lb

- Base weight calculated on standard machine configuration with 14.00-24 12PR (G-2) tires, full fuel tank, coolant, lubricants and operator.
- Typical operating weight calculated on standard machine configuration with Cab High Profile ROPS, rear ripper, push block, 14.00-24 12PR (G-2) tires, full fuel tank, coolant, lubricants and operator.
- Maximum Vehicle Weight includes all compatible attachments with Cab High Profile ROPS, 17.50-25 12PR (G-2) tires, full fuel tank, coolant, lubricants and operator.

Standards

ROPS/FOPS	ISO 3471:1994/ ISO 3449:2005
Steering	ISO 5010:2007
Brakes	ISO 3450:1996
Sound	ISO 6394:2008 ISO 6396:2008

- These standards are met when the machine is equipped with a cab.
- The static operator sound pressure level is 77 dB(A) when “ISO 6394:2008” is used to measure the value for an enclosed cab. The measurement was conducted with the cab doors and the cab windows closed. The cab was properly installed and maintained.

160K Motor Grader Specifications

Engine

Engine Model	Cat C7 ACERT	
Base Power (1st gear) – Net	139 kW	186 hp
Base Power (1st gear) – Net (Metric)		189 hp
VHP Range – Net	139-154 kW	186-206 hp
VHP – gears		
1-2 Net	139 kW	186 hp
3 Net	147 kW	196 hp
4-8 Net	154 kW	206 hp
1-2 Gross	151 kW	203 hp
3 Gross	159 kW	213 hp
4-8 Gross	166 kW	223 hp
Displacement	7.2 L	439 in ³
Bore	105 mm	4.1 in
Stroke	127 mm	5 in
Torque Rise	46%	
Maximum Torque Net	1076 N·m	794 lb ft
Speed @ rated power	2,000 rpm	
Number of cylinders	6	
Derating altitude	3048 m	10,000 ft
Fan Speed Maximum	1,925 rpm	
High Ambient Capability	50° C	122° F

- Net power is tested per ISO 9249, SAE J1349, and EEC 80/1269 standards in effect at the time of manufacture.
- Net power advertised is the power available at rated speed of 2,000 rpm, measured at the flywheel when engine is equipped with fan, air cleaner, muffler and alternator.
- Maximum torque measured at 1,000 rpm in gears 4-8.

Power Train

Forward/Reverse Gears	8 forward/6 reverse	
Transmission	Direct drive, Power shift	
Brakes		
Service	Air actuated, multiple oil-disc	
Service, surface area	23 948 cm ²	3,712 in ²
Parking	Air actuated, multiple oil-disc	
Secondary	Dual circuit	

- Brakes meet the following standards: SAE J/ISO 3450 JAN 98.

Operating Specifications

Top Speed		
forward	46.9 km/h	29.1 mph
reverse	37.0 km/h	23.0 mph
Turning Radius, outside front tires	7.5 m	24 ft 9 in
Steering Range – left/right	47.5 Degrees	
Articulation Angle – left/right	20 Degrees	
Forward		
1st	4.1 km/h	2.5 mph
2nd	5.5 km/h	3.4 mph
3rd	8.1 km/h	5.0 mph
4th	11.1 km/h	6.9 mph
5th	17.2 km/h	10.7 mph
6th	23.4 km/h	14.6 mph
7th	32.2 km/h	20.0 mph
8th	46.9 km/h	29.1 mph
Reverse		
1st	3.2 km/h	2.0 mph
2nd	6.0 km/h	3.7 mph
3rd	8.8 km/h	5.4 mph
4th	13.6 km/h	8.4 mph
5th	25.4 km/h	15.8 mph
6th	37.0 km/h	23.0 mph

- Maximum travel speeds calculated at rated rpm on standard machine configuration with 17.50-25 12PR (G-2) tires.

Hydraulic System

Circuit Type	Load Sensing, Closed Center, Proportional Priority Pressure Compensating System	
Pump Type	Variable Piston	
Pump Output Standard Pump	159.1 L/min	42 gal/min
Optional High Output Pump	210.5 L/min	55.6 gal/min
Maximum System Pressure	25 500 kPa	3,698.5 psi
Standby Pressure	3600 kPa	522.1 psi
Reservoir Tank Capacity	55 L	14.5 gal

- Pump output measured @ 2,150 rpm.

Moldboard

Blade Width	4.3 m	14 ft
Moldboard height	686 mm	27 in
thickness	25 mm	1 in
Arc Radius	413 mm	16.3 in
Throat Clearance	90 mm	3.5 in
Cutting Edge width	203 mm	8 in
thickness	16 mm	0.6 in
End Bit width	152 mm	6 in
thickness	16 mm	0.6 in
Blade Pull base GVW	9626 kg	21,221 lb
maximum GVW	13 379 kg	29,496 lb
Down Pressure base GVW	7609 kg	16,775 lb
maximum GVW	13 964 kg	30,785 lb

- Blade Pull calculated at 0.9 traction coefficient, which is equal to ideal no-slip conditions, and Gross Vehicle Weight (GVW).

160K Motor Grader Specifications

Blade Range

Circle Centershift		
right	728 mm	28.7 in
left	752 mm	29.6 in
Moldboard Sideshift		
right	943 mm	37.1 in
left	851 mm	33.5 in
Maximum Blade Position Angle	90 Degrees	
Blade Tip Range		
forward	40 Degrees	
backward	5 Degrees	
Maximum shoulder reach outside of tires		
right	2261 mm	89 in
left	2223 mm	87.5 in
Maximum lift above ground	452 mm	17.8 in
Maximum depth of cut	790 mm	31.1 in

Ripper

Ripping depth – maximum	462 mm	18.2 in
Ripper shank holders, quantity	5	
Ripper shank holder spacing	533 mm	21 in
Penetration force	9095 kg	20,051 lb
Pryout force	12 112 kg	26,703 lb
Machine length increase, beam raised	970 mm	38.2 in
Scarifier shank holder quantity	9	

Scarifier

Mid, V-Type		
Working width	1184 mm	46.6 in
Scarifying depth, maximum	229 mm	9 in
Scarifier shank holders quantity	11	
Scarifier shank holder spacing	116 mm	4.6 in
Rear		
Working width	2300 mm	90.6 in
Scarifying depth, maximum	266 mm	10.5 in
Scarifier shank holders quantity	9	
Scarifier shank holder spacing	267 mm	10.5 in

- The mid-mount scarifier is positioned under the drawbar between the moldboard and front axle.

Frame

Circle		
diameter	1553 mm	61.1 in
blade beam thickness	40 mm	1.6 in
Drawbar		
height	127 mm	5 in
width	76.2 mm	3 in
Front axle		
height to center	628 mm	24.7 in
wheel lean, left/right	18 Degrees	
total oscillation	32 Degrees	
Front-top/bottom plate		
width	305 mm	12 in
thickness	25 mm	1 in
Front-side plates		
width	242 mm	9.5 in
thickness	12 mm	0.5 in
Front-linear weights		
minimum	165 kg/m	112 lb/ft
maximum	213 kg/m	144 lb/ft
Front-section modulus		
minimum	2083 cm ³	127 in ³
maximum	4785 cm ³	291 in ³
Tandems		
Height	572 mm	22.5 in
Width	201 mm	7.9 in
Sidewall thickness		
inner	16 mm	0.6 in
outer	18 mm	0.7 in
Drive chain pitch	51 mm	2 in
Wheel axle spacing	1522 mm	59.9 in
Tandem oscillation		
front up	15 Degrees	
front down	25 Degrees	

160K Motor Grader Specifications

Service Refill

Fuel Capacity	344 L	91 gal
Cooling system	40 L	10.6 gal
Engine Oil	18 L	4.8 gal
Transmission/ Differential/ Final Drives	60 L	15.9 gal
Tandem housing (each)	80 L	21.1 gal
Front wheel spindle bearing housing	0.5 L	0.1 gal
Circle drive housing	7 L	1.8 gal

Weights

Gross Vehicle Weight – Base		
total	15 057 kg	33,195 lb
front axle	4362 kg	9,616 lb
rear axle	10 695 kg	23,579 lb
Gross Vehicle Weight – Typically Equipped		
total	18 275 kg	40,289 lb
front axle	5243 kg	11,559 lb
rear axle	13 032 kg	28,731 lb
Gross Vehicle Weight – Maximum		
total	22 870 kg	50,420 lb
front axle	8005 kg	17,647 lb
rear axle	14 866 kg	32,773 lb

- Base weight calculated on standard machine configuration with 14.00-24 12PR (G-2) tires, full fuel tank, coolant, lubricants and operator.
- Typical operating weight calculated on standard machine configuration with Cab High Profile ROPS, rear ripper, push block, 14.00-24 12PR (G-2) tires, full fuel tank, coolant, lubricants and operator.
- Maximum Vehicle Weight includes all compatible attachments with Cab High Profile ROPS, 17.50-25 12PR (G-2) tires, full fuel tank, coolant, lubricants and operator.

Standards

ROPS/FOPS	ISO 3471:1994/ ISO 3449:2005
Steering	ISO 5010:2007
Brakes	ISO 3450:1996
Sound	ISO 6394:2008 ISO 6396:2008

- These standards are met when the machine is equipped with a cab.
- The static operator sound pressure level is 77 dB(A) when “ISO 6394:2008” is used to measure the value for an enclosed cab. The measurement was conducted with the cab doors and the cab windows closed. The cab was properly installed and maintained.

K Series Specifications

Dimensions

All dimensions are approximate.

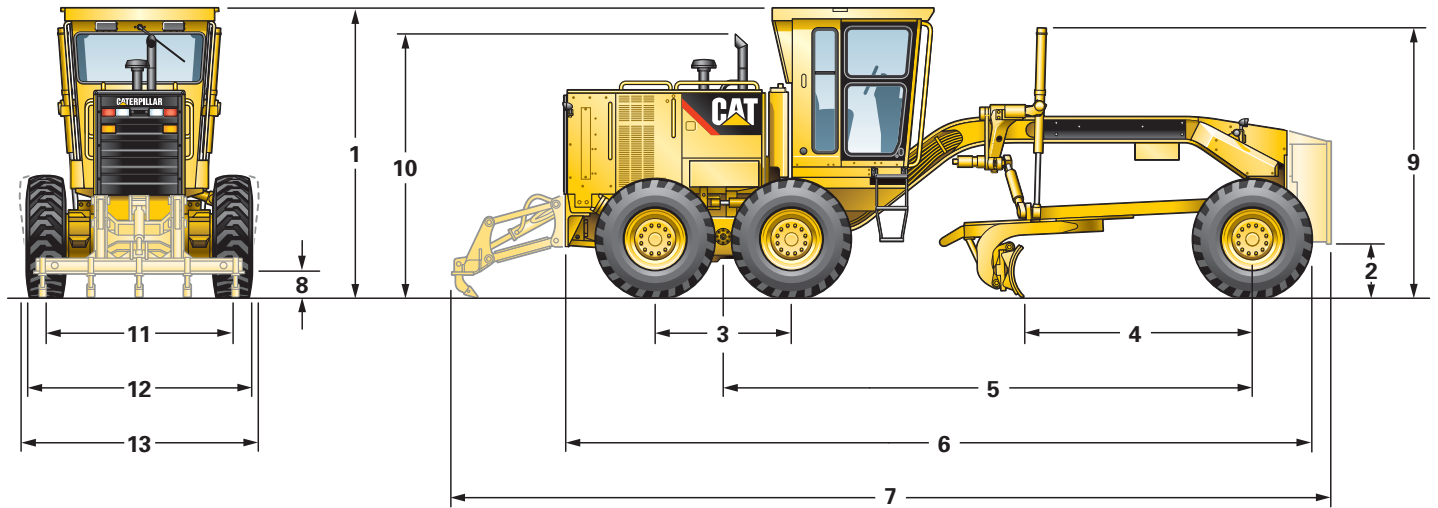

	120K		12K		140K		160K	
	mm	in	mm	in	mm	in	mm	in
1 Height – ROPS Cab	3326	131.0	3354	132.0	3354	132.0	3354	132.0
Height – Non-ROPS Cab	3321	130.7	3348	131.8	3348	131.8	3348	131.8
Height – ROPS Canopy	3326	131.0	3354	132.0	3354	132.0	3354	132.0
2 Ground Clearance – Center Front Axle	602	23.7	626	24.6	626	24.6	626	24.6
3 Length – Between Tandem Axles	1510	59.4	1523	60.0	1523	60.0	1523	60.0
4 Length – Front Axle to Moldboard	2598	102.3	2598	102.3	2598	102.3	2598	102.3
5 Length – Front Axle to Mid Tandem	5870	231.1	6086	239.6	6086	239.6	6086	239.6
6 Length – Front Tire to Rear of Machine	8265	325.4	8504	334.8	8504	334.8	8504	334.8
7 Length – Counterweight to Ripper	9769	384.6	10 013	394.2	10 013	394.2	10 013	394.2
8 Ground Clearance, Trans. Case	341	13.4	362	14.3	362	14.3	362	14.3
9 Height – Top of Cylinders	2885	113.6	3049	120.0	3049	120.0	3049	120.0
10 Height to Exhaust Stack	2865	112.8	2895	114.0	2895	114.0	2895	114.0
11 Width – Tire Center Lines	2056	80.9	2065	81.3	2065	81.3	2065	81.3
12 Width – Outside Rear Tires	2439	96.0	2452	96.6	2452	96.6	2452	96.6
13 Width – Outside Front Tires	2449	96.4	2481	97.7	2481	97.7	2481	97.7

Standard equipment may vary. Consult your Cat dealer for details.

ELECTRICAL

Alternator, 115 Ampere
Backup alarm, reversing lights
Batteries, maintenance free 750 CCA
Electrical system, 24 volt
Horn, electric
Lights, stop and tail
Motor, starting
Product Link Ready
Working lights

OPERATOR ENVIRONMENT

Accelerator
Control console, adjustable
Gauge cluster (includes voltmeter, articulation, engine coolant temperature, air brake pressure and fuel level)
Guard rails, operator station
Hydraulic controls, load sensing (right/left blade lift, circle drive, centershift, sideshift, front wheel lean and articulation)
Indicator lights (includes high beam, LH and RH turn, low engine oil pressure, throttle lock, check engine, transmission filter bypass and check, centershift pin, brake air pressure, parking brake engaged, auto shift)
Key start/stop switch
Meter, hour
Power steering, hydraulic
Seat, vinyl-covered static
Seat belt
Steering wheel, tilt, adjustable
Storage area, cooler/lunch box
Throttle, electronic control

POWER TRAIN

Air cleaner, dry type radial seal with service indicator and automatic dust ejector
Air to air after cooler (ATAAC)
Blower fan
Brakes, oil disc, four-wheel air actuated
Differential with lock/unlock
Engine, Cat C7 with ACERT Technology, diesel with automatic engine derate and idle control. Meets non-current U.S. EPA Tier 2 and EU Stage II emission standards.
Fuel water separator
Muffler, under hood
Parking brake, multi-disc, sealed and oil cooled
Prescreener
Priming pump, fuel, resiliently mounted
Sediment drain, fuel tank
Tandem drive
Transmission, 8 speed forward and 6 speed reverse, power shift, direct drive with electronic shift control and overspeed protection
VHP (Variable Horse Power)

OTHER STANDARD EQUIPMENT

Bumper, rear
CD ROM Parts Book
Circle drive slip clutch
Cutting edges, 152 mm × 16 mm (6 in × 5/8 in) curved DH-2 steel
Doors, Engine compartment
Drawbar, 4 shoe (120K) or 6 shoe (12K, 140K, 160K) replaceable nylon composite wear strips
Endbits, 16 mm (5/8 in) DH-2 steel
Frame, articulated with safety lock
Fuel tank, 305 L (80.6 gal)
Fuel tank, 344 L (91 gal) (160K only)
Ground level engine shutdown
Link bar, 7 position
Moldboard, 3658 mm × 610 mm × 22 mm (12 ft × 24 in × 7/8 in) blade with hydraulic sideshift and mechanical tip (120K, 12K, 140K)
Moldboard, 4267 mm × 686 mm × 25 mm (14 ft × 27 in × 1 in) blade with hydraulic sideshift and tip (160K only)
S-O-S ports, engine, hydraulic, transmission and cooling
Toolbox with padlock
Vandalism protection – including cap locks for hydraulic tank, radiator access cover, fuel tank, engine and transmission oil check/fill and lockable battery boxes.

ANTIFREEZE

Extended Life Coolant to -35° C (-30° F)

K Series Optional Equipment

Optional equipment may vary. Consult your Caterpillar dealer for details.

	kg	lb		kg	lb		kg	lb
GUARDS			RIPPER/SCARIFIER (12K, 140K, 160K only)			HYDRAULICS		
Guard, transmission	98	216	Ripper/Scarifier, rear mounted*	-961	-2,119	Pump, hydraulic, high capacity (210 L/min 55.7 gal/min)	2	4
OPERATOR ENVIRONMENT			Scarifier, mid mounted, V-type			Hydraulic arrangements with one or more additional hydraulic valves are available for rear ripper, mid-mount scarifier, dozer, snow plow and snow wing.		
Air conditioner with heater	91	201	LIGHTS (12K, 140K, 160K only)			BLADES, MOLDBOARDS		
Heater, cab	14	31	Bar mounted, low, directional and headlights	13	29	Moldboard, Deluxe (120K only)		
CAB/CANOPY			Cab and bar mounted, high, directional, headlights and work lights			Blade, 3658 mm × 610 mm × 22 mm (12' × 24" × 7/8") with hydraulic side shift and tip and 5/8" end bits cutting edge 203 mm × 19 mm (8" × 3/4")		
Cab, ROPS*	0	0	POWER TRAIN			Moldboard (12K, 140K, 160K only)		
Cab, Non-ROPS*	-182	-401	Autoshift	2	4	Blade, 4267 mm × 610 mm × 22 mm (14' × 24" × 7/8")	93	205
Canopy, ROPS*	-118	-260	OTHER ATTACHMENTS			Blade, front		
Seat, vinyl adjustable	14	31	Product Link	5	10	Cutting edge, 203 mm × 19 mm (8" × 3/4"). For use with 14' blade	1180	2,601
Seat, cloth, contour	11	24	Snow Wing Mounting, frame-ready	91	201	Endbits, overlay, reversible pair for use with 203 mm (8") cutting edges	11	24
Fan, defroster, front window	2	4	AccuGrade ARO					
Fan, defroster, rear window	2	4	Dryer, air	13	29			
Sun shade, rear	3	7	Push plate, counterweight*	-907	-2,000			
Wiper/washer, rear	7	15	Accumulator, blade lift	77	170			
Wipers, intermittent front	1	2	Battery, extreme duty (1400 CCA)	14	31			
Mirrors, dual inside	1	2	Ether, starting aid	1	2			
Mirrors, outside mounted	8	18	Heater, engine coolant, 220V	1	2			
Power port, 12V accessory	2	4						
Radio ready entertainment	5	11						
Tachometer/Speedometer	1	2						

* Weights represent changes to Typically Equipped machine weights.

K Series Motor Graders

For more complete information on Cat products, dealer services, and industry solutions, visit us on the web at www.cat.com

© 2013 Caterpillar Inc.
All rights reserved

Materials and specifications are subject to change without notice. Featured machines in photos may include additional equipment. See your Cat dealer for available options.

CAT, CATERPILLAR, SAFETY.CAT.COM, their respective logos, "Caterpillar Yellow" and the "Power Edge" trade dress, as well as corporate and product identity used herein, are trademarks of Caterpillar and may not be used without permission.

AEHQ6891 (01-2013)

