

Rosemount™ 400 and 400 VP

Contacting Conductivity Sensors

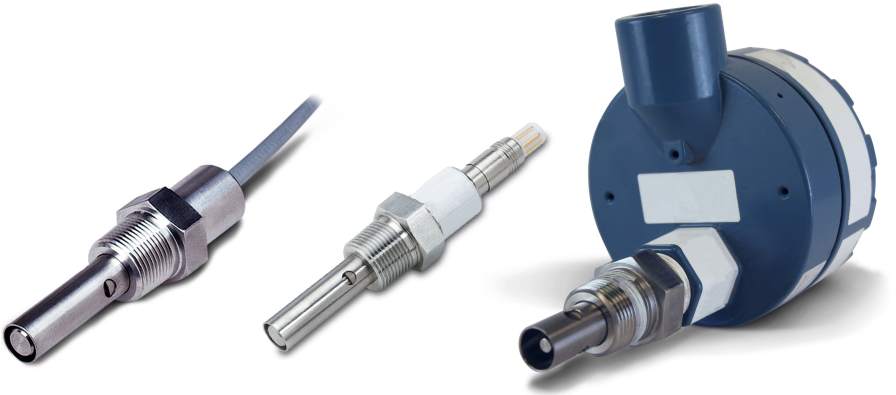

Essential Instructions

Read this page before proceeding!

Emerson designs, manufactures, and tests its products to meet many national and international standards. Because these instruments are sophisticated technical products, you must properly install, use, and maintain them to ensure they continue to operate within their normal specifications. You must adhere to the following instructions and integrate them into your safety program when installing, using, and maintaining Emerson's Rosemount products. Failure to follow the proper instructions may cause any one of the following situations to occur: loss of life, personal injury, property damage, damage to this instrument, and warranty invalidation.

- Read all instructions prior to installing, operating, and servicing the product.
- If you do not understand any of the instructions, contact your Emerson representative for clarification.
- Follow all warnings, cautions, and instructions marked on and supplied with the product.
- Inform and educate your personnel in the proper installation, operation, and maintenance of the product.
- To ensure proper performance, use qualified personnel to install, operate, update, program, and maintain the product.
- When replacement parts are required, ensure that qualified people use replacement parts specified by Emerson. Unauthorized parts and procedures can affect the product's performance, place the safe operation of your process at risk, and VOID YOUR WARRANTY. Look-alike substitutions may result in fire, electrical hazards, or improper operation.
- Ensure that all equipment doors are closed and protective covers are in place, except when maintenance is being performed by qualified people, to prevent electrical shock and personal injury.

Note

The information contained in this document is subject to change without notice.

WARNING

Hazardous area installation

Installations near flammable liquids or in hazardous area locations must be carefully evaluated by qualified on site safety personnel.

To secure and maintain intrinsically safe installation, use an appropriate transmitter/safety barrier/sensor combination. The installation system must be in accordance with the governing approval agency (FM, CSA, or BASEEFA/CENELEC) hazardous area classification requirements. Consult your transmitter Reference Manual for details.

Proper installation, operation, and servicing of this sensor in a hazardous area installation are entirely the operator's responsibility.

WARNING

Physical access

Unauthorized personnel may potentially cause significant damage to and/or misconfiguration of end users' equipment. This could be intentional or unintentional and needs to be protected against.

Physical security is an important part of any security program and fundamental to protecting your system. Restrict physical access by unauthorized personnel to protect end users' assets. This is true for all systems used within the facility.

Contents

Specifications..... 5

Install the sensor..... 7

Calibrate and maintain..... 22

Troubleshoot..... 27

Accessories..... 31

1 Specifications

Wetted materials	
Electrodes	Titanium
Insulator	Glass filled PEEK
Hex block	316 stainless steel
O-ring	EPDM
Temperature range	
Standard	32 to 221 °F (0 to 105 °C)
With optional integral junction box	32 to 392 °F (0 to 200 °C)
Maximum pressure	
250 psig (1825 kPa [abs])	
Vacuum	
At 1.6-in. Hg (5.2 kPa), air leakage is less than 0.005 SCFM (0.00014 m ³ /min.)	
Cell constants	
0.01, 0.1, and 1.0/cm	
Process connection	
¾-in. (19.1 mm) male national pipe thread (MNPT)	
Cable length	
10 ft. (3 m) standard; for longer cable lengths, choose option -60 (integral junction box) and order interconnecting cable separately; interconnecting VP6 cables sold separately (see Accessories).	

Table 1-1: Weights and Shipping Weights

Rounded up to the nearest 1 lb. or 0.5 kg.

Sensor	Weight	Shipping weight
Rosemount 400 with 10-ft. (3.1 m) integral cable	1 lb. (0.5 kg)	2 lb. (1.0 kg)
Rosemount 400 with 50-ft. (15.2 m) integral cable	4 lb. (2.0 kg)	5 lb. (2.5 kg)
Rosemount 400VP with Variopol cable connection	1 lb. (0.5 kg)	2 lb. (1.0 kg)

Table 1-1: Weights and Shipping Weights (continued)

Sensor	Weight	Shipping weight
Rosemount 400 with integral junction box	3 lb. (1.5 kg)	4 lb. (2.0 kg)

Table 1-2: Flow Cell (24092-02) Specifications

Wetted materials	
Body and nut	Polycarbonate and polyester
¼-in. (6.4 mm) fittings	316 stainless steel
O-ring	Silicone
Process connection	
Compression fittings for ¼-in. (6.4 mm) OD tubing	
Temperature range	
32 to 158 °F (0 to 70 °C)	
Maximum pressure	
90 psig (722 kPa [abs])	

2 Install the sensor

Keep $\frac{1}{4}$ in. (6.4 mm) clearance between electrodes and piping. The electrodes must be completely submerged in the process liquid (i.e., to the level of the threaded connection). See [Figure 2-1](#) to [Figure 2-6](#) for recommended orientation and installation. You can install Rosemount 400/400VP sensors with 0.1 and 1.0/cm cell constants in $\frac{3}{4}$ -in. (19.1 mm) pipe tees. You can also install the sensors in 1-in. (25.4 mm) tees with a $\frac{3}{4}$ -in. (19.1 mm) bushing.

If the sensor is installed in a pipe tee or flow cell with the sample draining to open atmosphere, bubbles may accumulate on the electrodes. Trapped bubbles will cause errors. As bubbles accumulate, the conductivity reading normally drifts down. In the plastic flow cell, bubbles are readily visible. To control bubble formation, apply a small amount of back pressure to the flow cell or pipe tee.

Figure 2-1: Sensor Orientation

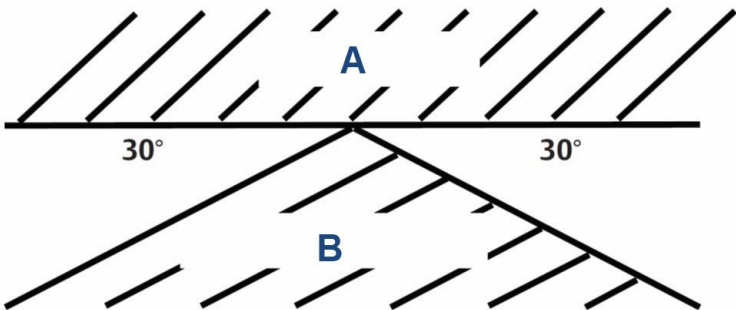

- A. Trapped air
- B. Trapped sludge

Figure 2-2: Direct Insertion in a Pipe

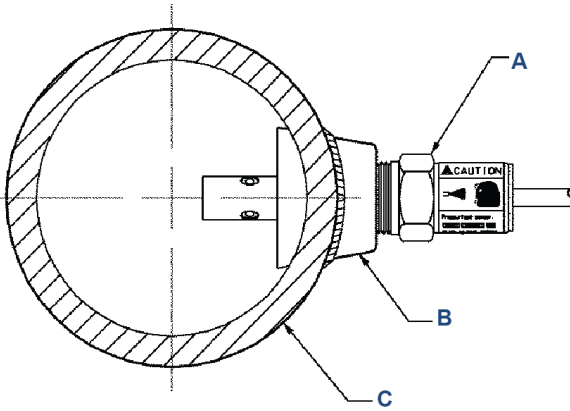

- A. Sensor
- B. Weldolet
- C. Process piping

Figure 2-3: Insertion in a Pipe Tee

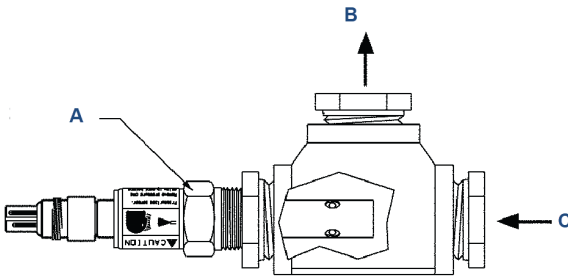

1-in. (25.4 mm) pipe tee with 3/4-in. (19.1 mm) bushing shown

- A. Sensor
- B. Outlet
- C. Inlet

Figure 2-4: Insertion in a Pipe Tee

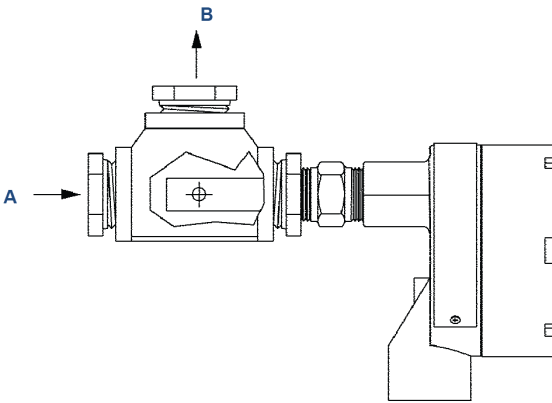

1-in. pipe tee with 3/4-in. bushing shown.

- A. Inlet
- B. Outlet

Figure 2-5: Insertion in a Pipe Tee

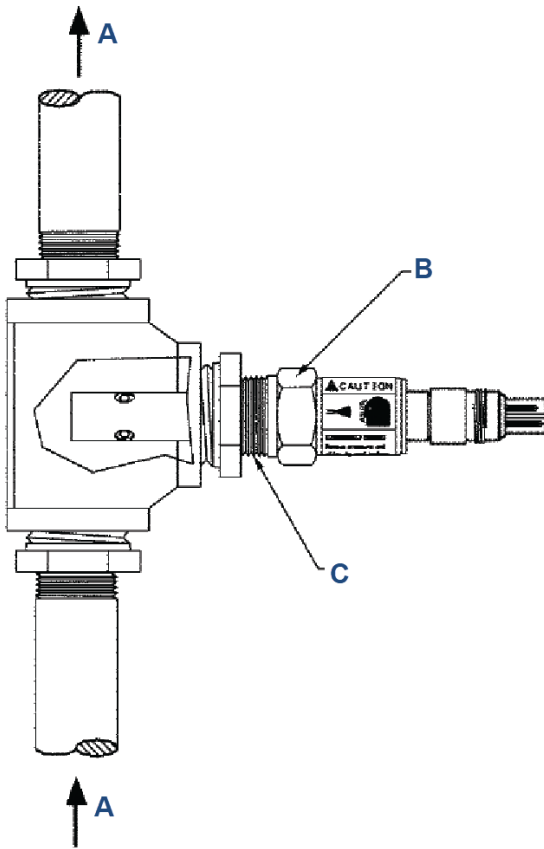

- A. Flow
- B. Sensor
- C. $\frac{3}{4}$ -in. (19.1 mm) male national pipe thread (MNPT), typical

Figure 2-6: Insertion in a Flow Cell (24091-02)

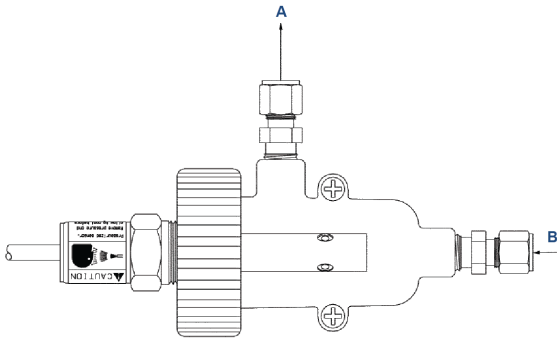

- A. Outlet
- B. Inlet

Figure 2-7: Rosemount 400 with Integral Cable Connection Dimensional Drawing

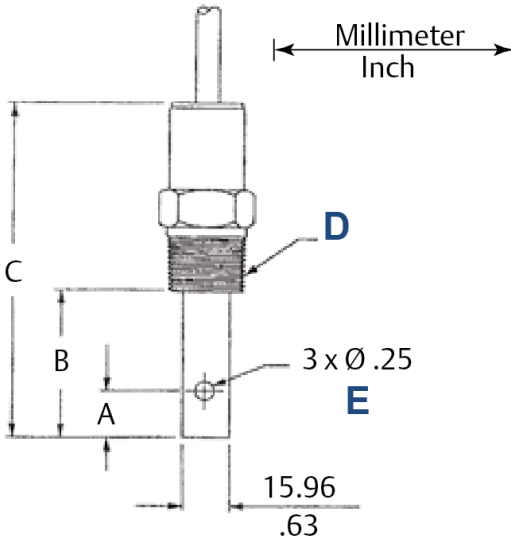

- A. Dimension (see [Table 2-1](#))
- B. Dimension (see [Table 2-1](#))
- C. Dimension (see [Table 2-1](#))
- D. 3/4-in. (19.1 mm) - 14 national pipe thread (NPT)
- E. Equally spaced

Table 2-1: Rosemount 400 with Integral Cable Connection Dimensions

Sensor configuration	A		B		C	
	in.	mm	in.	mm	in.	mm
0.01/cm	1.59	40.39	1.98	50.34	4.52	114.8
0.1/cm	0.687	17.45	1.11	28.15	3.65	92.71
1.0/cm	0.667	16.94	1.13	28.70	3.67	93.22
0.01/cm (with extended insertion length)	1.59	40.39	5.49	139.4	8.00	203.2
0.1/cm (with extended insertion length)	0.687	17.45	5.49	139.4	8.00	203.2
1.0/cm (with extended insertion length)	0.667	16.94	5.49	139.4	8.00	203.2

Figure 2-8: Rosemount 400 with Integral Junction Box Dimensional Drawing

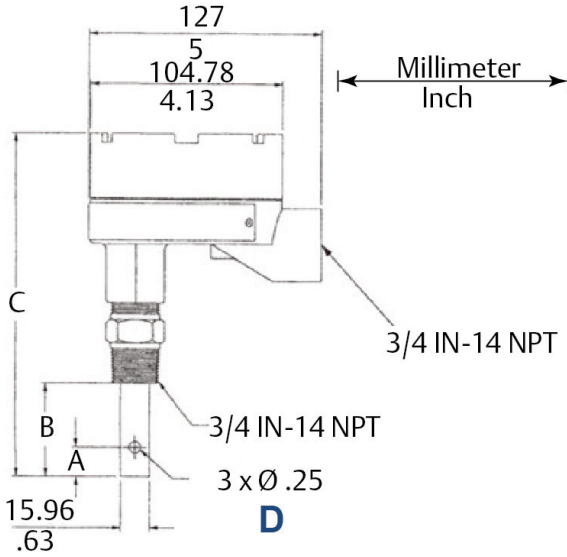

- A. Dimension (see Table 2-2)
- B. Dimension (see Table 2-2)
- C. Dimension (see Table 2-2)
- D. Equally spaced

Table 2-2: Rosemount 400 with Integral Junction Box Dimensions

Sensor configuration	A		B		C	
	in.	mm	in.	mm	in.	mm
0.01/cm	1.59	40.39	1.98	50.34	7.41	188.2
0.1/cm	0.687	17.45	1.11	28.15	6.49	164.9
1.0/cm	0.667	16.94	1.13	28.70	6.51	165.4
0.01/cm (with extended insertion length)	1.59	40.39	5.49	139.4	10.90	276.9

Table 2-2: Rosemount 400 with Integral Junction Box Dimensions (continued)

Sensor configuration	A		B		C	
	in.	mm	in.	mm	in.	mm
0.1/cm (with extended insertion length)	0.687	17,45	5.49	139,4	10.90	276,9
1.0/cm (with extended insertion length)	0.667	16.94	5.49	139.4	10.90	276.9

Figure 2-9: Rosemount 400VP with Variopol Cable Connection

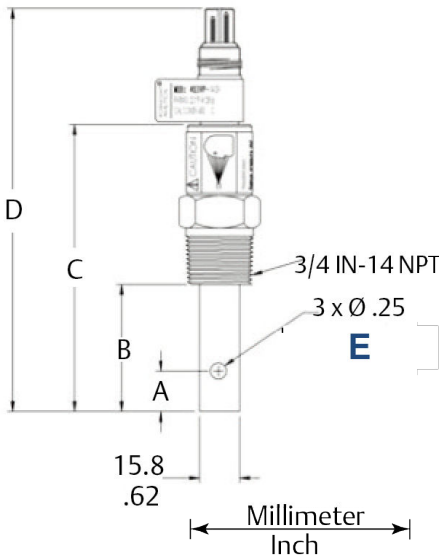

- A. Dimension (see [Table 2-3](#))
- B. Dimension (see [Table 2-3](#))
- C. Dimension (see [Table 2-3](#))
- D. Dimension (see [Table 2-3](#))
- E. Equally spaced

Table 2-3: Rosemount 400VP with Variopol Cable Dimensions

Sensor configuration	A		B		C		D	
	in.	mm	in.	mm	in.	mm	in.	mm
0.01/cm	1.59	40.39	1.98	50.34	4.43	112.5	6.3	160.0
0.1/cm	0.67	17.0	1.10	27.9	3.47	90.4	5.43	137.9
1.0/cm	0.67	17.0	1.10	27.9	3.58	90.9	5.45	138.4
0.01/cm (with extended insertion length)	1.59	40.39	5.48	139.2	7.91	200.9	9.78	284.4
0.1/cm (with extended insertion length)	0.67	17.0	5.48	139.2	7.91	200.9	9.78	284.4
1.0/cm (with extended insertion length)	0.67	17.0	5.48	139.2	7.91	200.9	9.78	284.4

2.1 Wire the sensor

For additional wiring information, refer to [Emerson.com/RosemountLiquidAnalysisWiring](https://www.emerson.com/en-us/rosemount-liquid-analysis-wiring).

Table 2-4: Wire Color and Connections in Sensor

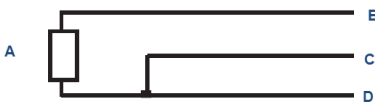
Color	Function
Gray	Connects to outer electrode
Clear	Coaxial shield for gray wire
Orange	Connects to inner electrode
Clear	Coaxial shield for orange wire
Red	 <p>A. Resistance temperature device (RTD) B. RTD in C. RTD sense D. RTD return</p>
White with red stripe	
White	
Clear	Shield for all RTD lead wires

2.2 Wire the sensor to the transmitter

Figure 2-10: Wiring for Rosemount 56, 1056 and 1057 transmitters

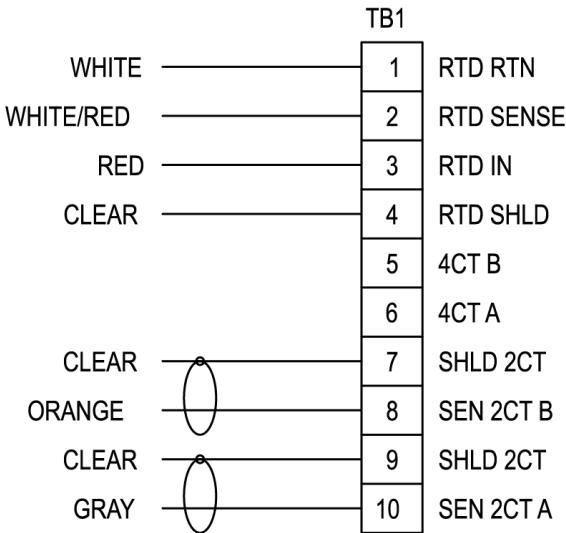

Table 2-5: Wiring for Rosemount 56, 1056, and 1057 Transmitters

Terminal number	Wire color	Connects to
1	White	Resistance temperature device (RTD) return
2	White/red	RTD sense
3	Red	RTD in
4	Clear	RTD shield
5	N/A	4CT-B
6	N/A	4CT-A
7	Clear	Shield 2CT
8	Orange	Sensor 2CT-B
9	Clear	Shield 2CT
10	Gray	Sensor 2CT-A

Figure 2-11: Wiring for Rosemount 1066 transmitter

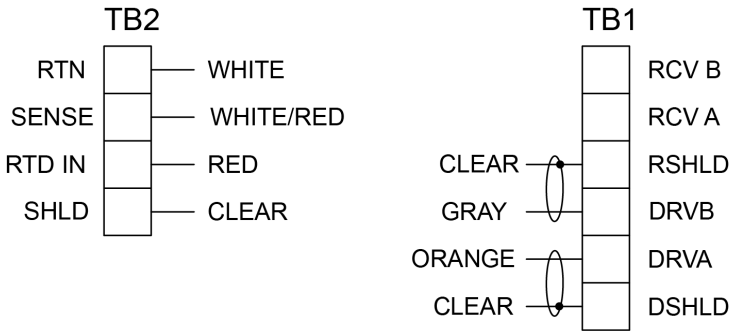

Table 2-6: Wiring for Rosemount 1066 Transmitter

Terminal block	Wire color	Connects to
TB2	White	RTD return
TB2	White/red	RTD sense
TB2	Red	RTD in
TB2	Clear	Shield
TB1	N/A	Receive B
TB1	N/A	Receive A
TB1	Clear	Receive shield
TB1	Gray	Drive B
TB1	Orange	Drive A
TB1	Clear	Drive shield

Figure 2-12: Wiring for Rosemount 5081 transmitter

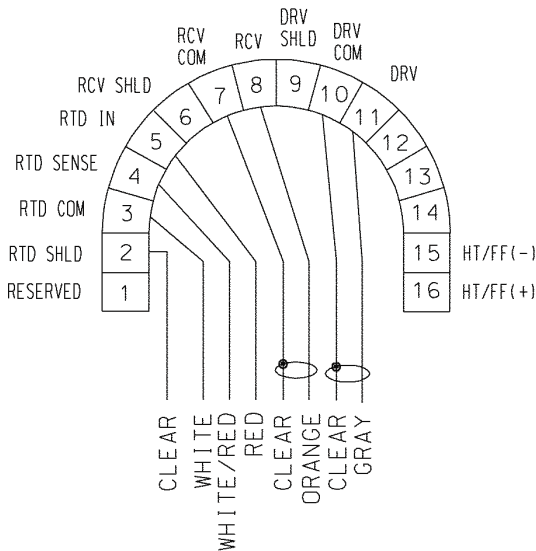

Table 2-7: Wiring for Rosemount 5081 Transmitter

Terminal number	Wire color	Connects to	Terminal number	Wire color	Connects to
1	N/A	Reserved	9	N/A	Drive shield
2	Clear	RTD shield	10	Clear	Drive common
3	White	RTD return	11	Gray	Drive
4	White/red	RTD sense	12	N/A	N/A
5	Red	RTD in	13	N/A	N/A
6	N/A	Receive shield	14	N/A	N/A
7	Clear	Receive common	15	N/A	HART®/ FOUNDATION™ Fieldbus (-)
8	Orange	Receive	16	N/A	HART/ FOUNDATION Fieldbus (+)

2.2.1 Wire through junction box

Rosemount 400 Contacting Conductivity Sensors can have an optional integral junction box mounted on the end of the sensor.

See [Figure 2-13](#) for wiring instructions. If wiring through a remote junction box (PN 23550-00), wire point-to-point. Use cable 23747-00 (factory-terminated) or 9200275 (raw cable).

Figure 2-13: Sensor-Mounted Junction Box Wiring

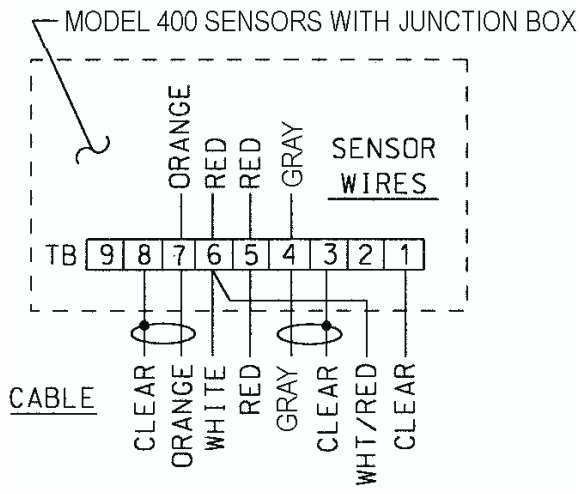

Table 2-8: Wiring Sensor to Junction Box

Terminal number	Sensor wire color	Junction box cable color
1	N/A	Clear
2	N/A	N/A
3	N/A	Clear
4	Gray	Gray
5	White	White
6	White	Red and white/red
7	Orange	Orange
8	N/A	Clear
9	N/A	N/A

Note

- The gray sensor wire is connected to the junction box, which makes electrical contact with the OUTER electrode.
 - Terminals in junction box are not numbered. Refer to transmitter wiring diagram for connections at transmitter.
-

Figure 2-14: Pin out diagram for Rosemount 400VP with Variopol cable connection

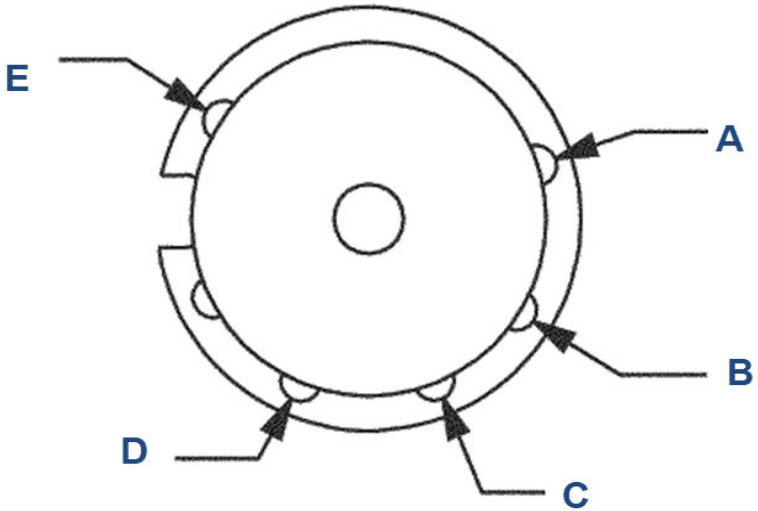

- A. Resistance temperature device (RTD) in
 - B. RTD return
 - C. Outer electrode
 - D. RTD sense
 - E. Inner electrode
-

3 Calibrate and maintain

3.1 Calibrating the sensor

Emerson calibrates the sensors at the factory, so they do not need calibration when they are first placed in service. Simply enter the cell constant printed on the label into the transmitter.

After a period of service, you may need to calibrate the sensor. For more information on calibration, refer to the [Application Data Sheet](#).

3.1.1 Calibrate using a standard solution

If using a standard solution, choose one having conductivity in the recommended operating range for the sensor cell constant.

Procedure

1. Immerse the rinsed sensor in the standard solution and adjust the transmitter reading to match the conductivity of the standard.
2. Calibrate the sensor.
For an accurate calibration:
 - a. Choose a calibration standard near the midpoint of the recommended conductivity range for the sensor.
 - b. Do not use calibration standards having conductivity less than 100 $\mu\text{S}/\text{cm}$.
 - c. Turn off automatic temperature compensation in the transmitter.
 - d. Use a standard for which the conductivity as a function of temperature is known.
 - e. Use a good quality calibrated thermometer with an error rate less than ± 0.1 °C to measure the temperature of the standard.
 - f. Follow good laboratory practice. Rinse the beaker and sensor at least twice with standard. Be sure the rinse solution reaches between the inner and outer electrodes by tapping and swirling the sensor while it is immersed in the standard.
 - g. Be sure air bubbles are not trapped between the electrodes. Place the sensor in the standard and tap and swirl to release bubbles. Note the reading and repeat. If readings agree, no trapped bubbles are present. Repeat until two subsequent readings agree.

3.1.2 Calibrate using a reference meter and sensor

Take the following precautions for a successful calibration:

1. If the normal conductivity of the process liquid is less than about $1.0 \mu\text{S}/\text{cm}$, adjust the conductivity so that it is near the upper end of the operating range.

The difference between the conductivity measured by the process and reference meter usually has both a fixed (constant error) and relative (proportional error) component. Because the cell constant calibration assumes the error is proportional only, calibration at low conductivity allows the fixed component to have an outsized influence on the result.

For example, assume the only difference between reference meter and process sensor is fixed, and the process sensor always reads $0.002 \mu\text{S}/\text{cm}$ high. If the process sensor is calibrated at $0.100 \mu\text{S}/\text{cm}$, the new cell constant will be changed by $0.100/0.102$ or two percent. If the sensor is calibrated at $0.500 \mu\text{S}/\text{cm}$, the change will be only $0.500/0.502$ or 0.4 percent.

Calibration at higher conductivity produces a better result, because it minimizes the effect of the offset.

2. Orient the sensors so that air bubbles always have an easy escape path and cannot get trapped between the electrodes.
3. Turn off automatic temperature compensation in the transmitter. Almost all process conductivity transmitters feature automatic temperature compensation in which the transmitter applies one of several temperature correction algorithms to convert the measured conductivity to the value at a reference temperature, typically 77°F (25°C).

Although temperature correction algorithms are useful for routine measurements, do not use them during calibration for the following two reasons:

- a. No temperature correction is perfect. If the assumptions behind the algorithm do not perfectly fit the solution being measured, the temperature-corrected conductivity will be in error.
- b. If the temperature measurement itself is in error, the corrected conductivity will be in error.

The purpose of calibrating the sensor is to determine the cell constant. To minimize the error in the cell constant, eliminate all sources of avoidable error, e.g., temperature compensation.

4. Keep tubing runs between the sensors short and adjust the sample flow as high as possible. Short tubing runs and high flow ensure that

the temperature of the liquid does not change as it flows from one sensor to another.

If the process temperature is appreciably different from ambient, high flow may not be enough to keep the temperature constant. In this case, you may need to pump sample at room temperature from a reservoir through the sensors. Because such a system is likely to be open to atmosphere, saturate the liquid with air to prevent drift caused by absorption of atmospheric carbon dioxide.

5. To prevent contamination of low conductivity ($< 1 \mu\text{S}/\text{cm}$) process liquids, use clean tubing to connect the sensors. To prevent drift caused desorption of ionic contaminants from tube walls, keep the sample flow greater than 6 ft./sec (1.8 m/sec).

Procedure

1. Connect the process sensors and reference sensor in series and allow the process liquid to flow through all sensors.
2. Calibrate the process sensor by adjusting the process transmitter reading to match the conductivity measured by the reference meter. See [Figure 3-1](#) for the calibration setup.

Figure 3-1: In Process Calibration Setup

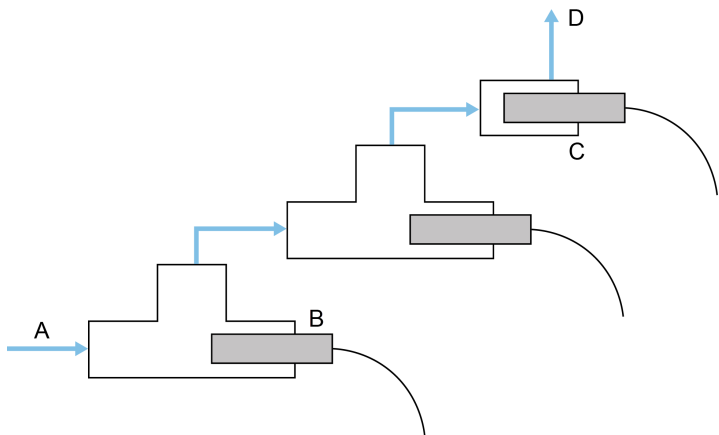

- A. Sample inlet
- B. In process sensors
- C. Reference sensor
- D. Sample output

Note

[Figure 3-1](#) shows two process sensors connected in series with a reference sensor. The horizontal sensor orientation ensures good

circulation of the process liquid past the electrodes. The staircase orientation provides an escape path for bubbles.

This method is ideal for calibrating the sensors used in low conductivity water (0.01/cm cell constants), because the calibration system is closed and cannot be contaminated by atmospheric carbon dioxide.

3.1.3 Calibrate using a grab sample

Use the grab sample method when it is impractical to remove the sensor for calibration or to connect a reference sensor to the process line.

Procedure

Take a sample of the process liquid, measuring its conductivity using a reference instrument and adjusting the reading from the process transmitter to match the measured conductivity.

Take the sample from a point as close to the process sensor as possible.

Keep temperature compensation turned on. There is likely to be a lag time between sampling and analysis, so temperature is likely to change.

Be sure the reference and process instruments are using the same temperature correction algorithm.

Only use grab sample calibration when the conductivity is fairly high.

- a. The temperature compensation algorithm will most likely be linear slope.
- b. Confirm that both instruments are using the same temperature coefficient in the linear slope calculation.
- c. If the reference meter does not have automatic temperature correction, calculate the conductivity at 77 °F (25 °C) using the equation:

$$C_{25} = \frac{C_t}{1 + \alpha(t - 25)}$$

where: C_{25} = the conductivity at 25 °C

C_t = the conductivity at t °C

α = the temperature coefficient expressed as a decimal fraction

- d. Confirm the temperature measurements in both the process and reference instruments are accurate, ideally to within ± 0.5 °C.
- e. Follow good laboratory practice when measuring the conductivity of the grab sample.
 - Rinse the beaker and sensor at least twice with sample. Be sure the rinse solution reaches between the inner and outer

electrodes by tapping and swirling the sensor while it is immersed in the sample.

- Be sure air bubbles are not trapped in the sensor. Place the sensor in the sample and tap and swirl to release bubbles. Note the reading. Then, remove the sensor and return it to the sample. Tap and swirl again and note the reading. If the two readings agree, there are no trapped bubbles. If they do not agree, bubbles are present. Continue the process until two subsequent readings agree.
 - While measuring, do not allow the sensor to touch the sides and, particularly, the bottom of the beaker. Keep at least ¼ in. (6 mm) clearance.
- f. Be sure to compensate for process conductivity changes that might have occurred while the grab sample was being tested. Rosemount conductivity transmitters (Rosemount 1056, 1066, and 56) do this automatically. They save the value of the process conductivity at the time the sample was taken and use that value to calculate the new cell constant when you enter the result of the grab sample test. Older transmitters do not remember the process conductivity value. Therefore, you must enter a value adjusted by an amount proportional to the change in the process conductivity. For example, suppose the process conductivity is 810 $\mu\text{S}/\text{cm}$ when the sample is taken and 815 $\mu\text{S}/\text{cm}$ when the test result is entered. If the grab sample conductivity is 819 $\mu\text{S}/\text{cm}$, enter $(815/810) \times 819$ or 824 $\mu\text{S}/\text{cm}$.

3.2 Clean the sensor

Procedure

Use a warm detergent solution and a soft brush or pipe cleaner to remove oil and scale.

You can also use isopropyl alcohol to remove oily films. Avoid using strong mineral acids to clean conductivity sensors.

4 Troubleshoot

4.1 Off-scale reading

Potential cause

Wiring is incorrect.

Recommended action

Verify and correct wiring.

Potential cause

Temperature element is open or shorted.

Recommended action

Check temperature element for open or short circuits.

See [Figure 4-1](#).

Figure 4-1: Checking the Temperature Element

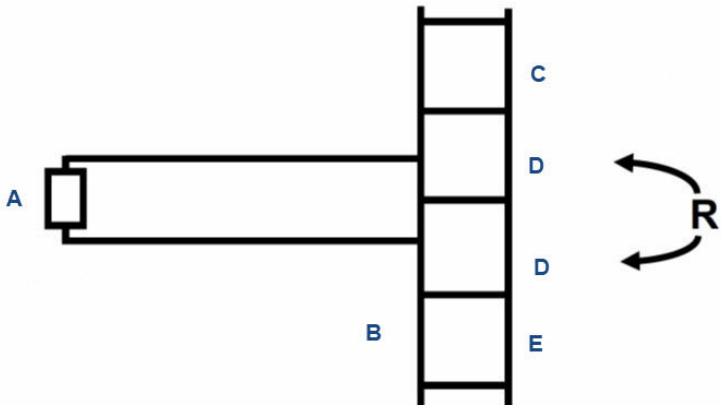

- A. Resistance temperature device
- B. Terminal strip in sensor junction box
- C. Orange
- D. Red
- E. Gray

Potential cause

Sensor is not in process stream.

Recommended action

Submerge sensor completely in process stream.

Potential cause

Variopool cable is not properly seated.

Recommended action

Loosen connector and reset.

Potential cause

Sensor has failed.

Recommended action

Perform isolation checks.

See [Figure 4-2](#).

Figure 4-2: Checking the Continuity and Leakage

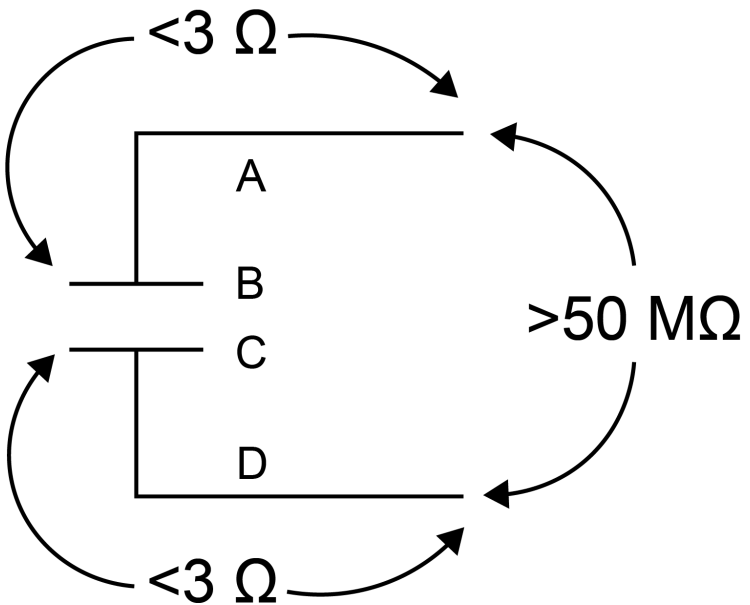

- A. Orange
- B. Inner
- C. Outer
- D. Gray

4.2 Noisy reading

Potential cause

Sensor is improperly installed in process stream.

Recommended action

Submerge sensor completely in process stream.

Potential cause

Variopol cable is not properly seated.

Recommended action

Loosen connector and reset.

4.3 Reading seems wrong (lower or higher than expected)

Potential cause

Bubbles trapped in sensor.

Recommended actions

1. Ensure the sensor is properly oriented in pipe or flow cell.
See [Figure 2-1](#).
2. Apply back pressure to flow cell.

Potential cause

Wrong temperature correction algorithm is being used.

Recommended action

Check that the temperature correction is appropriate for the sample.
See transmitter Reference Manual for more information.

Potential cause

Wrong cell constant.

Recommended action

Verify that the correct cell constant has been entered in the transmitter and that the cell constant is appropriate for the conductivity of the sample.

See transmitter Reference Manual.

4.4 Sluggish response

Potential cause

Electrodes are fouled.

Recommended action

Clean electrodes.

Potential cause

Sensor is installed in dead area in piping.

Recommended action

Move sensor to a location more representative of the process liquid.

4.5 Check the temperature element

Procedure

Disconnect leads and measure resistance shown.

The measured resistance should be close to the value in the following table.

Temperature (°C)	Resistance in ohms	
	Pt 100	Pt 1000
0	100.0	1000
10	103.9	1039
20	107.8	1078
30	111.7	1117
40	115.5	1155
50	119.4	1194

See [Figure 4-1](#).

4.6 Check the continuity and leakage

Procedure

Disconnect electrode leads and measure resistance and continuity as shown in [Figure 4-2](#).

The sensor must be dry when checking resistance between electrode leads.

5 Accessories

Part number	Description
23747-06	Junction box for a remote cable connection
9200275	Connecting cable, unterminated, specify length
23747-00	Connecting cable, terminated, specify length
24091-02	Low flow cell for Rosemount 400/400VP sensors
05010781899	Conductivity standard SS-6, 200 $\mu\text{S}/\text{cm}$, 32 oz. (0.95 L)
05010797875	Conductivity standard, SS-6A, 200 $\mu\text{S}/\text{cm}$, 1 gal. (3.78 L)
05010782468	Conductivity standard, SS-5, 1000 $\mu\text{S}/\text{cm}$, 32 oz. (0.95 L)
05010783002	Conductivity standard SS-5A, 1000 $\mu\text{S}/\text{cm}$, 1 gal. (3.78 L)
05000705464	Conductivity standard, SS-1, 1409 $\mu\text{S}/\text{cm}$, 32 oz. (0.95 L)
05000709672	Conductivity standard, SS-1A 1409 $\mu\text{S}/\text{cm}$, 1 gal. (3.78 L)
05010782147	Conductivity standard SS-7, 5000 $\mu\text{S}/\text{cm}$, 32 oz. (0.95 L)
05010782026	Conductivity standard SS-7A, 5000 $\mu\text{S}/\text{cm}$, 1 gal. (3.78 L)
23747-06	2.5-ft. (0.8 m) interconnecting VP6 cable
23747-04	6.4-ft. (1.2 m) interconnecting VP6 cable
23747-02	10-ft. (3.0 m) interconnecting VP6 cable
23747-07	15-ft. (4.6 m) interconnecting VP6 cable
23747-08	20-ft. (6.1 m) interconnecting VP6 cable
23747-09	25-ft. (7.6 m) interconnecting VP6 cable
23747-10	30-ft. (9.1 m) interconnecting VP6 cable
23747-03	50-ft. (15.2 m) interconnecting VP6 cable
23747-11	100-ft. (30.5 m) interconnecting VP6 cable



GLOBAL HEADQUARTERS

6021 Innovation Blvd.
Shakopee, MN 55379

 +1 866 347 3427

 +1 952 949 7001

 RMTNA.RCCPO@Emerson.com

NORTH AMERICA

Emerson Automation Solutions
8200 Market Blvd
Chanhassen, MN 55317

 Toll Free +1 800 999 9307

 F +1 952 949 7001

 RMTNA.RCCPO@Emerson.com

EUROPE

Emerson Automation Solutions
Neuhofstrasse 19a PO Box 1046
CH-6340 Baar
Switzerland

 +41 (0) 41 768 6111

 +41 (0) 41 768 6300

 RMTNA.RCCPO@Emerson.com

MIDDLE EAST AND AFRICA

Emerson Automation Solutions
Emerson FZE
Jebel Ali Free Zone
Dubai, United Arab Emirates, P.O. Box
17033

 +971 4 811 8100

 +971 4 886 5465

 RMTNA.RCCPO@Emerson.com

ASIA-PACIFIC

Emerson Automation Solutions
1 Pandan Crescent
Singapore 128461
Republic of Singapore

 +65 6 777 8211

 +65 6 777 0947

 RMTNA.RCCPO@Emerson.com

 [LinkedIn.com/company/Emerson-Automation-Solutions](https://www.linkedin.com/company/Emerson-Automation-Solutions)

 [Twitter.com/rosemount_news](https://twitter.com/rosemount_news)

 [Facebook.com/Rosemount](https://www.facebook.com/Rosemount)

 [Youtube.com/RosemountMeasurement](https://www.youtube.com/RosemountMeasurement)

©2020 Emerson. All rights reserved.

The Emerson logo is a trademark and service mark of Emerson Electric Co. Rosemount is a mark of one of the Emerson family of companies. All other marks are the property of their respective owners.