



Modular Pumping Packages

TABLE OF CONTENTS

Section/Para	Page	Section/Para	Page
1 INTRODUCTION	1-1	5.3 OIL TANK AND RESERVOIR 15 AMP LOW-LEVEL ASSEMBLY MAINTENANCE (OPTIONS L1, L2 and L3)	5-2
1.1 GENERAL	1-1	5.4 OIL TANK RESERVOIR 10-WATT LOW-LEVEL ASSEMBLY MAINTENANCE (OPTIONS L5, L6 AND L7)	5-4
1.2 GENERAL SYSTEM OPERATION	1-2	5.5 GREASE RESERVOIR LOW-LEVEL ASSEMBLY MAINTENANCE (OPTION L4)	5-5
2 RESERVOIRS AND TANKS	2-1	6 HIGH-PRESSURE AND BLOWOUT SWITCHES	6-1
2.1 DESCRIPTION	2-1	6.1 DESCRIPTION	6-1
2.2 MOUNTING INSTRUCTIONS	2-1	6.2 HIGH-PRESSURE SWITCH ADJUSTMENT	6-2
2.3 PREPARATION FOR USE	2-2	6.3 MOUNTING INSTRUCTIONS	6-3
2.4 GREASE RESERVOIR MAINTENANCE (OPTIONS GP1 THROUGH GP5 AND GM1 THROUGH GM4)	2-3	6.4 HIGH-PRESSURE SWITCH MAINTENANCE (OPTION P1)	6-3
2.5 OIL RESERVOIR MAINTENANCE (OPTIONS OP1 THROUGH OP4)	2-7	6.5 RESERVOIR BLOWOUT SWITCH MAINTENANCE (OPTIONS P2 and P3)	6-4
2.6 OIL TANK MAINTENANCE (OPTIONS T1, T2 and T3)	2-11	6.6 TANK BLOWOUT SWITCH MAINTENANCE (OPTION P4)	6-6
3 PUMPS	3-1	7 PNEUMATIC SOLENOID OPTIONS	7-1
3.1 DESCRIPTION	3-1	8 CONTROLLERS	8-1
3.2 PREPARATION FOR USE	3-3	8.1 DESCRIPTION	8-1
3.3 PNEUMATIC PUMP MAINTENANCE (OPTIONS A1 THROUGH A6)	3-3	8.2 WIRING	8-2
3.4 HYDRAULIC PUMP MAINTENANCE (OPTIONS H1 AND H3)	3-9	9 SYSTEM OPERATION	9-1
3.5 HYDRAULIC PUMP MAINTENANCE (OPTION H2)	3-13	9.1 GENERAL	9-1
4 MANIFOLDS	4-1	9.2 SYSTEM INFORMATION	9-1
4.1 DESCRIPTION	4-1	9.3 OPERATING TIPS	9-1
4.2 PREPARATION FOR USE	4-1	9.4 MATERIAL CONSIDERATIONS	9-2
4.3 MAINTENANCE	4-1	10 TROUBLESHOOTING	10-1
5 LOW-LEVEL SWITCHES	5-1	10.1 GENERAL	10-1
5.1 DESCRIPTION	5-1		
5.2 MOUNTING INSTRUCTIONS	5-1		

LIST OF ILLUSTRATIONS

Number	Title	Page	Number	Title	Page
1-1.	Modu-Flo Functional Schematic	1-3	5-2.	Oil Tank and Reservoir 10-Watt Low-Level Assembly	5-5
2-1.	Grease Reservoir - Exploded View	2-5	5-3.	Grease Reservoir Low-Level Assembly	5-6
2-2.	Oil Reservoir - Exploded View	2-9	6-1.	High-Pressure Switch	6-2
2-3.	Oil Tank - Exploded View	2-13	6-2.	High-Pressure Switch (Rear View)	6-4
3-1.	Typical Pump Operation	3-2	6-3.	Reservoir Blowout Switch Assembly (Front View)	6-5
3-2.	Pneumatic Pump, Exploded View	3-7	6-4.	Tank Blowout Switch Assembly	6-7
3-3.	Hydraulic Pump Options H1 and H3 - Exploded View	3-11	7-1.	Pneumatic Solenoid	7-1
3-4.	Hydraulic Pump Option H2 - Exploded View	3-15	8-1.	DC Timer Wiring Schematic	8-2
4-1.	Typical Manifold Assembly	4-3	8-2.	AC Timer Wiring Schematic	8-2
5-1.	Oil Tank and Reservoir 15 Amp Low-Level Assembly	5-3	8-3.	TC1000 Timer/Counter Wiring Schematic	8-3
			8-4.	WMP Maxi-Monitor Wiring Schematic	8-3

LIST OF TABLES

Number	Title	Page
2-1.	Reservoirs and Tanks	2-2
2-2.	Grease Reservoir Parts List	2-4
2-3.	Oil Reservoir Parts Lists	2-8
2-4.	Oil Tank Parts List	2-12
3-1.	Pumps	3-2
3-2.	Pneumatic Pump Parts List	3-5
3-3.	Hydraulic Pump Options H1 and H3 Parts List	3-10
3-4.	Hydraulic Pump Option H2 Parts List	3-14
4-1.	Operating Ports on Modu-Flo Manifolds	4-2
4-2.	Manifolds and Manifold Accessories	4-2
5-1.	Low-Level Switch Assemblies	5-2
5-2.	Oil Tank and Reservoir 15 Amp Low-Level	

Assemblies Parts List	5-3
-----------------------------	-----

Number	Title	Page
5-3.	Oil Tank and Reservoir 10-Watt Low-Level Assemblies Parts List	5-5
5-4.	Grease Reservoir Low-Level Assembly Parts List	5-6
6-1.	Blowout Discs and Kits	6-1
6-2.	High-Pressure and Blowout Switch Assemblies	6-2
6-3.	Pressure Switch Settings	6-3
6-4.	High-Pressure Switch Parts List	6-4
6-5.	Reservoir Blowout Switch Parts List	6-5
6-6.	Tank Blowout Switch Parts List	6-6
7-1.	Pneumatic Solenoid Parts List	7-1
10-1.	Modu-Flo Troubleshooting	10-1

OPERATION AND SERVICE INSTRUCTIONS

Modu-Flo® System

SECTION 1

INTRODUCTION

1.1	GENERAL.....	1-1
	1.1.1 Standard Components.....	1-1
	1.1.2 Modu-Flo Options.....	1-1
1.2	GENERAL SYSTEM OPERATION.....	1-1

1.1 GENERAL

1.1.1 Standard Components. A wide choice of modular components may be assembled to meet a given application.

1.1.1.1 All Modu-Flo systems consist of the following components:

- a. A reservoir or tank for holding the lubricant. Reservoirs are cylindrical units for grease or oil and are equipped with a spring-loaded follower for grease applications. Tanks are rectangular and are used for applications using oil. Further information on reservoirs may be found in Section 2.
- b. A pump for dispensing a specific volume of lubricant. Pumps may be pneumatically or hydraulically operated. A selection of power ratios and displacement ranges are available. Further information on pumps may be found in Section 3.
- c. A manifold attached to the base of the reservoir to provide a mounting base for any pump. The manifold has all the necessary porting to allow lubricant to flow from the reservoir to the pump and from the pump to the lubricant lines. Ports are also provided for pneumatic or hydraulic inputs to operate the pump. Accessories such as gauges and blowout assemblies are available and may be connected to the manifold. If the pump is to be located some distance from the reservoir, a wall-mounted manifold is available. Further information on manifolds is contained in Section 4.

1.1.2 Modu-Flo Options.

1.1.2.1 Options which are available for any system include the following:

- a. Low-level switches which mount to the reservoir or tank and provide a low-level fault signal to a customer-designated component. Level switch options are described in Section 5.
- b. High-pressure indicators which are installed into the pump outlet circuit and provide an over-pressure signal to external components. Pressure switch options are discussed in Section 6.
- c. A pneumatic solenoid valve which mounts directly to the manifold. The solenoid valve is a three-way, normally-closed type. Use of the solenoid allows the pump to be cycled by various controller options. The solenoid is equipped with a manual override button which may be used to simplify system testing, line filling and line bleeding.
- d. Several types of controllers are used which can be adapted to the system. Controller options are discussed in Section 8. Controllers available are as follows:
 - (1) Timers which may be set to cycle the pump at given intervals. Both AC and DC models are available.
 - (2) A TC-1000 timer can operate the lube system on either a time or machine cycle basis. It is available in 12 or 24 VDC or 115 or 230 VAC.
 - (3) A WMP Maxi-Monitor which provides a dispense signal on either a time or machine cycle basis. The WMP also monitors and displays the status of the lube system it is controlling. The Maxi-Monitor is available in either 115 or 230 VAC.

1.2 GENERAL SYSTEM OPERATION

1.2.1 Figure 1-1 shows a functional schematic of a Modu-Flo system.

1.2.1.1 The following steps outline the operating sequence of a Modu-Flo system:

- a. Lubricant stored in the reservoir or tank flows to the manifold. The manifold may be mounted directly to the reservoir or tank, or it may be mounted on a wall.
- b. The manifold directs lubricant into the pump to fill the pump chamber.
- c. A controller energizes a solenoid valve to dispense and the solenoid sends air or hydraulic fluid to the manifold. Porting in the manifold directs the air or hydraulic fluid to the pump, causing the pump to dispense lube to the manifold outlet port.
- d. When the controller releases the solenoid, air or hydraulic fluid is redirected, causing the pump to retract. On single-acting pneumatic pumps a spring pushes the pump to the retracted position.
- e. Lubricant from the reservoir flows through the manifold and refills the empty chamber in the pump.
- f. A pressure gauge, blowout disc, and high-pressure switch are options which may be connected to the output lube on the manifold. A signal from the pressure switch can be used to actuate an alarm or warning light.
- g. Low-level switch options are available for all tanks or reservoirs. The switch provides an electrical signal when lubricant level is low.

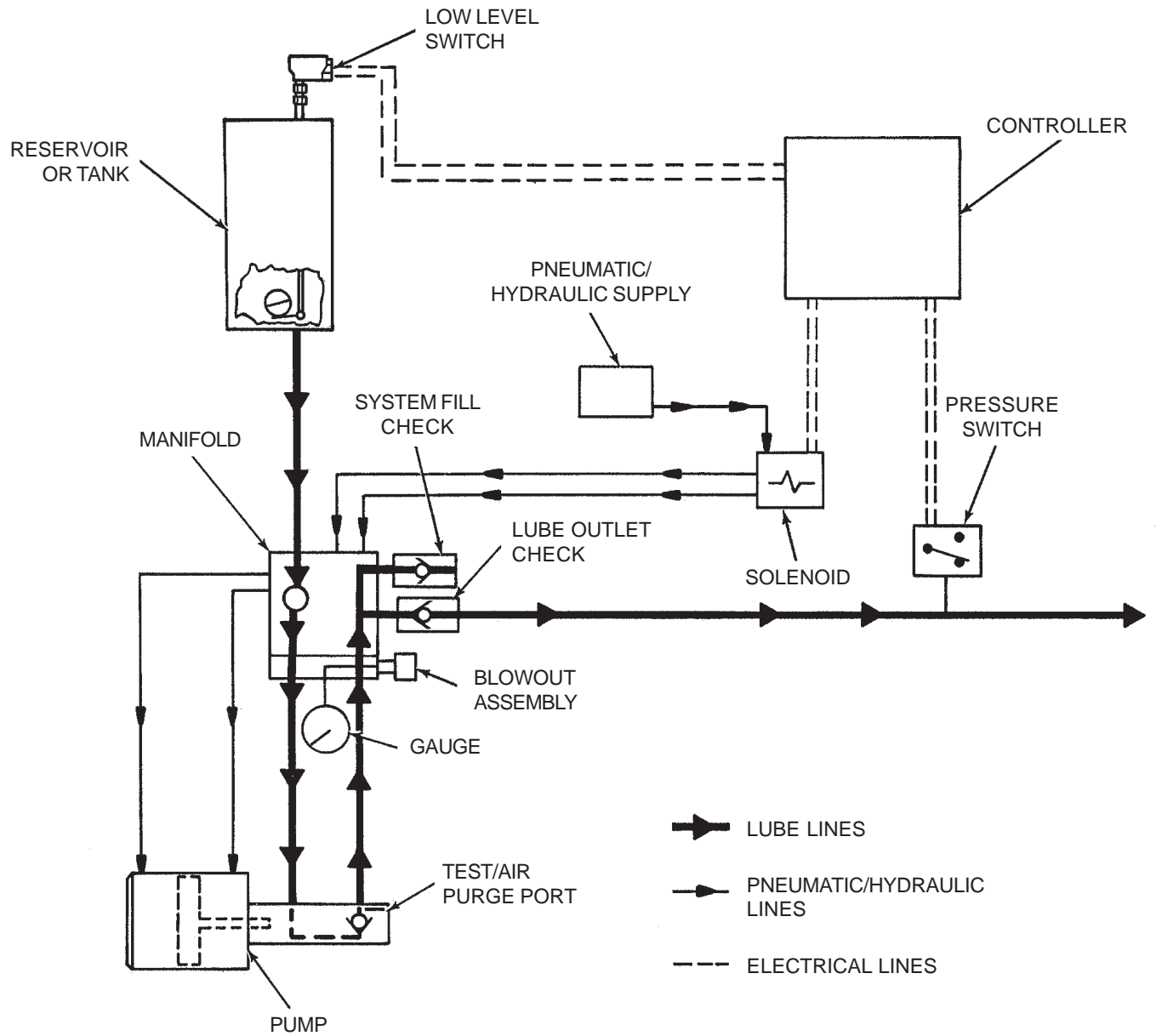

Figure 1-1. Modu-Flo Functional Schematic

OPERATION AND SERVICE INSTRUCTIONS

Modu-Flo® System

SECTION 2

RESERVOIRS AND TANKS

<p>2.1 DESCRIPTION 2-1</p> <p style="padding-left: 20px;">2.1.1 Reservoir Description 2-1</p> <p style="padding-left: 20px;">2.1.2 Tank Description 2-1</p> <p style="padding-left: 20px;">2.1.3 Reservoirs and Tanks Available 2-1</p> <p>2.2 MOUNTING INSTRUCTIONS 2-1</p> <p>2.3 PREPARATION FOR USE 2-2</p> <p style="padding-left: 20px;">2.3.1 Filling Oil Reservoirs and Tanks 2-2</p> <p style="padding-left: 20px;">2.3.2 Filling Grease Reservoirs 2-2</p> <p>2.4 GREASE RESERVOIR MAINTENANCE (OPTIONS GP1 THROUGH GP5 AND GM1 THROUGH GM4) 2-3</p> <p style="padding-left: 20px;">2.4.1 General 2-3</p> <p style="padding-left: 20px;">2.4.2 Grease Reservoir Maintenance 2-3</p> <p style="padding-left: 20px;">2.4.3 Disassembly of Grease Reservoirs 2-3</p> <p style="padding-left: 20px;">2.4.4 Assembly of Grease Reservoirs 2-3</p>	<p style="padding-left: 20px;">2.4.5 Grease Reservoir Parts Lists 2-3</p> <p>2.5 OIL RESERVOIR MAINTENANCE (OPTIONS OP1 THROUGH OP4) 2-7</p> <p style="padding-left: 20px;">2.5.1 General 2-7</p> <p style="padding-left: 20px;">2.5.2 Oil Reservoir Maintenance 2-7</p> <p style="padding-left: 20px;">2.5.3 Disassembly of Oil Reservoir 2-7</p> <p style="padding-left: 20px;">2.5.4 Assembly of Oil Reservoir 2-7</p> <p style="padding-left: 20px;">2.5.5 Oil Reservoir Parts Lists 2-7</p> <p>2.6 OIL TANK MAINTENANCE (OPTIONS T1, T2 and T3) 2-11</p> <p style="padding-left: 20px;">2.6.1 General 2-11</p> <p style="padding-left: 20px;">2.6.2 Oil Tank Maintenance 2-11</p> <p style="padding-left: 20px;">2.6.3 Disassembly of Oil Tanks 2-11</p> <p style="padding-left: 20px;">2.6.4 Assembly of Oil Tanks 2-11</p> <p style="padding-left: 20px;">2.6.5 Oil Tank Parts List 2-11</p>
--	---

2.1 DESCRIPTION

2.1.1 Reservoir Description. Reservoirs are cylindrical in shape and are used for either grease or oil lubricants. If a reservoir is to be used for grease it will be equipped with a spring-loaded follower which will apply pressure on the grease to force it into the pump. Reservoirs use cylinders made of metal or plastic. If a metal cylinder is used, the reservoir will be equipped with a level indicator to allow a visual check of lubricant level. Plastic cylinders are clear, allowing personnel to actually see the amount of lubricant present. The base of all reservoirs has the necessary tapped holes for either direct mounting of a manifold or for installing hose or tubing to a remote-located manifold.

2.1.2 Tank Description. Tanks are rectangular weldments used for holding oil. All tanks are equipped with a sight glass to allow personnel to easily check the lubricant level. A pad mounted to the tank base provides the necessary tapped holes for either direct mounting of a manifold or for installing hose or tubing to a remote-located manifold.

2.1.3 Reservoirs and Tanks Available. Table 2-1 lists the tanks and reservoirs available for use. Listings in the option column are used to identify the reservoir or tank selected when a Modu-Flo system is ordered. The option used is

designated by the entry in the ordering code as shown below:

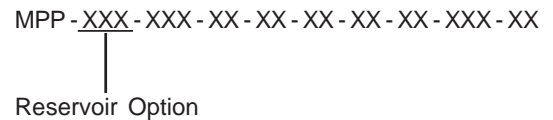

2.2 MOUNTING INSTRUCTIONS

2.2.1 Reservoirs and tanks may be mounted to any vertical surface. All units have 7/16 inch holes for attaching bolts or screws. Cylindrical reservoirs have two holes, six inches apart, drilled in the base bracket. All tanks have four holes drilled in flanges according to the following rectangular dimensions:

- 9-7/8 wide by 7 inches high for T1 tanks
- 11-1/8 wide by 7 inches high for T2 tanks
- 16-3/8 wide by 7 inches high for T3 tanks

2.2.1.1 Make sure the mounting location allows clearance for any accessories attached to the tank or reservoir. Oil reservoirs and all tanks have a fill cup on the top. Make sure there is enough room above the fill cup to permit personnel to perform a filling operation without difficulty. Drill the required holes and attach the reservoir or tank to the vertical surface. Securely tighten all attaching hardware. Make sure that the reservoir or tank is level.

Table 2-1. Reservoirs and Tanks

Part Number	Type (Use)	Reservoir Capacity		Option
521-001-060	Tank (oil)	12 pint	(5.68 liters)	T1
521-001-070	Tank (oil)	24 pint	(11.4 liters)	T2
521-001-080	Tank (oil)	40 pint	(18.9 liters)	T3
185-100-080	Reservoir, Plastic (oil)	5 pint	(2.37 liters)	OP1
185-100-060	Reservoir, Plastic (oil)	12 pint	(5.68 liters)	OP2
185-100-070	Reservoir, Plastic (oil)	20 pint	(9.46 liters)	OP3
185-100-750	Reservoir, Plastic (oil)	6 pint	(2.84 liters)	OP4
185-100-040	Reservoir, Plastic (grease)	5 lbs	(2.27 kg)	GP1
185-100-000	Reservoir, Plastic (grease)	12 lbs	(5.44 kg)	GP2
185-100-010	Reservoir, Plastic (grease)	20 lbs	(9.07 kg)	GP3
185-100-760	Reservoir, Plastic (grease)	6 lbs	(2.72 kg)	GP4
185-101-080	Reservoir, Plastic (grease)	3 lbs	(1.36 kg)	GP5
185-100-050	Reservoir, Metal (grease)	5 lbs	(2.27 kg)	GM1
185-100-020	Reservoir, Metal (grease)	12 lbs	(5.44 kg)	GM2
185-100-030	Reservoir, Metal (grease)	20 lbs	(9.07 kg)	GM3
185-100-770	Reservoir, Metal (grease)	6 lbs	(2.72 kg)	GM4
185-101-100 *	Reservoir, Plastic (grease)	40 lbs	(18.14 kg)	--
185-101-110 *	Reservoir, Plastic (grease) w/low level indicator	40 lbs	(18.14 kg)	--
185-100-120 *	Reservoir, Plastic (grease) w/low level micro switch	40 lbs	(18.14 kg)	--

* These assemblies are not available through the normal MPP system, only by ordering the full part number.

2.3 PREPARATION FOR USE

NOTE

Before filling any reservoir or tank, a manifold should be attached to the base. The manifold has a check valve built into it which will prevent the lubricant from dripping out of the reservoir or tank. If the system has a remote-located manifold, make sure there is hose or tubing connected from the bottom of the reservoir or tank to the remote manifold.

2.3.1 Filling Oil Reservoirs and Tanks. Reservoirs and tanks for oil have a fill cup mounted on top. Wipe the area around the fill cup to avoid contamination during filling. Open the fill cup cap and slowly pour the oil into the fill cup. A strainer attached to the fill cup will remove large particles which may be present in the oil. When filling is complete, close fillcup cap and wipe any spillage.

2.3.2 Filling Grease Reservoirs.

WARNING

If a high-pressure, high-volume supply pump is used to fill grease reservoirs, excess pressure may not be completely released by the bleed hole in the reservoir wall. This could cause the reservoir to fracture, exposing personnel to flying particles and lubricant. Safety glasses must be worn during filling operations and the supply pump must be turned off and disconnected when filling is complete.

2.3.2.1 Filling of grease reservoirs requires that an external supply source be connected to the fill stud located in the base of the reservoir. To avoid introducing air into the system, make sure there is enough grease in the supply source to fill

the reservoir without being disconnected. Operate the supply source at a steady speed to allow air-free filling of the reservoir. Too fast of a fill speed may result in air pockets. The level of grease is checked by visual means. In reservoirs with plastic cylinders, the grease level may be seen through the cylinder. Reservoirs with metal cylinders have a level-indicator rod mounted on the cap which will indicate when the fill is complete.

NOTE

Excess lube forced into the reservoir after it has reached full level will be vented from a bleed hole in the reservoir tube. (See Warning above.)

2.3.2.2 When filling is complete, turn off the supply source and disconnect it from the fill stud. A check valve in the fill stud will prevent lubricant from being forced back out. A plastic dust cap is attached to the fill stud and should be installed over the fill stud to keep dirt from entering the system.

NOTE

For first time grease filling, or if the grease reservoir has been allowed to go empty, open the petcock in the bottom right side of the reservoir. Slowly begin to fill the reservoir, allowing air trapped under follower to exhaust out the open petcock. When grease free of air flows from the petcock, close petcock and continue to fill the reservoir until follower is at vent hole in reservoir tube (any remaining air and small amount of grease will exit vent).

Loosen system mainline connection at pump outlet. Operate pump until lubricant free of air flows from outlet port. Tighten mainline connection at pump. Pump is now free of air.

Note, for extreme cases where the pump will not take a prime, it may be helpful to inject several

ounces of heavy oil through the grease fill quick disconnect. The pump will then prime on oil pulling the grease behind it. If it becomes necessary to use this method, all injected oil should be discharged at the loosened system supply connection along with any air.

Refer to bulletin 12411 (Portable Filler-Pak) for manual operated fill pump.

2.4 GREASE RESERVOIR MAINTENANCE (OPTIONS GP1 THROUGH GP5 AND GM1 THROUGH GM4)

2.4.1 General. Maintenance tips, disassembly, and assembly procedures for grease reservoirs are discussed in Paragraphs 2.4.2, 2.4.3 and 2.4.4. An exploded view of a typical grease reservoir is shown in Figure 2-1 and should be referred to during the discussion.

2.4.2 Grease Reservoir Maintenance.

2.4.2.1 Maintenance on the grease reservoir consists of the steps described below:

- a. Visually inspect the reservoir for lubricant leaking between reservoir tube (8, Figure 2-1) and base (10). This may indicate a bad gasket (9) or that the hex nuts (12) are not tight. Torque the nuts to 5 ft lbs. If the leakage continues, replace gasket (9). Check for cracks and nicks in tube (8). Replace the tube as required.
- b. Visually inspect the reservoir tube (8) for dents which may restrict the movement of the follower cups (6 and 7). Replace the tube as required.

WARNING

Disconnect and lock out power before opening electrical enclosures or conduit connections. Serious injury may result from electrical shock.

2.4.3 Disassembly of Grease Reservoirs. Figure 2-1 shows a typical grease reservoir but does not include other Modu-Flo components which may be mounted to the reservoir. These components include the manifold, pump, level switches and high-pressure blowout switches. Disassembly of the reservoir may require that some of these components be removed. The manifold and pump do not normally require removal, but may be removed if desired. The level and blowout switches may or may not require removal, depending on the level of disassembly required. The electrical connections to the switches probably should be disconnected in order to remove various parts without restriction of movement by the electrical cord. The removal of these components is explained in other sections of the manual. Refer to the table of contents to find where the components are discussed.

2.4.3.1 The disassembly procedure may be performed with the reservoir mounted to the mounting surface. However, some mounting locations may be too restrictive to provide access to all components. If your particular installation requires dismantling of the reservoir, make sure the reservoir is drained of lubricant before removing the attaching hardware. This will reduce the weight of the reservoir and reduce

the chance of spillage. The disassembly procedure is as follows:

WARNING

Do not attempt to remove retaining ring (2) or cable assembly (5) (Figure 2-1) (or retaining ring (25) or guide rod (5) for Option GP5). Injury could result from sudden expansion of spring (4).

- a. Slowly open petcock (11) and allow lubricant to be forced from the reservoir into a bucket or similar container. Remove fill stud (15) and petcock (11) if necessary. Properly dispose of emptied grease.
- b. Remove hex nuts (12) and lockwashers (13) from tie rods (1). Remove tie rods (1) from cap (3).
- c. Lift reservoir tube (8) from base (10) keeping reservoir cap (3) in position on top of the tube.
- d. Slide reservoir tube (8) away from reservoir cap (3) until it is free of follower cup (7).
- e. Remove gasket (9) from bottom of reservoir tube (8).
- f. Further disassembly is only possible at the factory. If damage is apparent on the follower cups (6 and 7), cable assembly or guide rod (5), spring (4) or reservoir cap (3) the unit cannot be serviced and the reservoir assembly must be replaced.

2.4.4 Assembly of Grease Reservoirs.

NOTE

Before assembly, lubricate followers and tube inner diameter with the lubricant which is used in the system.

2.4.4.1 Assemble the grease reservoir according to the following procedure:

- a. Slide reservoir tube (8, Figure 2-1) over follower cup (7) being careful not to distort the follower cup lips. Slide reservoir tube (8) up until it contacts reservoir cap (3).
- b. Install new gasket (9) on bottom of reservoir tube (8).
- c. Place reservoir tube (8) with gasket (9) on base (10) and rotate reservoir cap (3) until holes in the cap line up with holes in the base (10).
- d. Install tie rods (1) through holes in reservoir cap (3) and base (10).
- e. Install lockwashers (13) and hex nuts (12) on tie rods (1) and torque to 5 ft lbs.
- f. Install fill stud (15), dust cap (14) and petcock (11) in base. Make sure petcock (11) is in the closed position.

2.4.4.2 When the assembly steps listed in the above paragraph have been completed, any Modu-Flo components which were removed to ease disassembly should be reinstalled on the reservoir.

2.4.5 Grease Reservoir Parts Lists. Table 2-2 identifies the parts indexed in Figure 2-1.

Table 2-2. Grease Reservoir Parts List

Item Number	Part Number	Description	Quantity
	185-100-040	RESERVOIR ASSEMBLY, 5 lbs (2.27 kg), plastic (GP1)	--
	185-100-000	RESERVOIR ASSEMBLY, 12 lbs (5.44 kg), plastic (GP2)	--
	185-100-010	RESERVOIR ASSEMBLY, 20 lbs (9.07 kg), plastic (GP3)	--
	185-100-760	RESERVOIR ASSEMBLY, 6 lbs (2.72 kg), plastic (GP4)	--
	185-101-080	RESERVOIR ASSEMBLY, 3 lbs (1.36 kg), plastic (GP5)	--
	185-100-050	RESERVOIR ASSEMBLY, 5 lbs (2.27 kg), metal (GM1)	--
	185-100-020	RESERVOIR ASSEMBLY, 12 lbs (5.44 kg), metal (GM2)	--
	185-100-030	RESERVOIR ASSEMBLY, 20 lbs (9.07 kg), metal (GM3)	--
	185-100-770	RESERVOIR ASSEMBLY, 6 lbs (2.72 kg), metal (GM4)	--
1	415-700-272	BOLT, Tie (5 lb., 12 lb.)	3
	415-700-271	BOLT, Tie (20 lb.)	3
	415-700-273	BOLT, Tie (6 lb.)	3
	415-020-190	BOLT, Tie (3 lb.)	3
2		RING, Retaining	1
3		CAP, Reservoir	1
4		SPRING	1
5		CABLE ASSEMBLY	1
6		GUIDE ROD	1
7		GUIDE, Follower	1
9	501-423-001	CUP Seal	1
		GASKET (6" Tube) (3,6,12, 20 lb.)	1
10	501-414-000	GASKET (4" Tube) (5 lb.)	1
	521-000-500	BASE, Aluminum (6" Tube) (6, 12, 20 lb.)	1
	521-000-530	BASE (4" Tube) (5 lb.)	1
	521-008-950	BASE, Black (6" Tube) (3 lb.)	1
11	501-970-000	PETCOCK	1
12	410-040-020	NUT, Hex, 5/16-18	3
13	421-010-020	LOCKWASHER, 5/16 inch	3
14	506-165-000	CAP, Dust	1
15	506-189-001 *	Reservoir Fill Stud	1
16	410-060-120	NUT, Hex, 5/16-18	1
17	511-041-000	PLATE, Backup	1
18	521-003-630	INDICATOR, Level (12 lb. Metal)	1
	521-003-640	INDICATOR, Level (20 lb. Metal)	1
	521-004-310	INDICATOR, Level (6 lb. Metal)	1
	521-003-620	INDICATOR, Level (5 lb. Metal)	1
19	185-100-720+	TUBE, Reservoir, plastic, 13 inches (330.2mm) x 4 inches (100 mm) outer diameter (5 lb.)	1
	185-100-730+	TUBE, Reservoir, plastic, 13 inches (330.2 mm) x 6.0 inches (152.4 mm) outer diameter (12 lb.)	1
	185-100-740+	TUBE, Reservoir, plastic, 20 inches (508 mm) x 6.0 inches (152.4 mm) outer diameter (20 lb.)	1
	185-100-990+	TUBE, Reservoir, plastic, 8.5 inches (215.9 mm) x 6.0 inches (152.4 mm) outer diameter (6 lb.)	1
	185-100-191+	TUBE, Reservoir, plastic, 5 inches (127 mm) x 6.0 inches (152.4 mm) outer diameter (3 lb.)	1
	185-101-187+	TUBE, Reservoir, metal, 13 inches (330.2 mm) x 4 inches (100 mm) outer diameter (5 lb.)	1
	185-101-188+	TUBE, Reservoir, metal, 13 inches (330.2 mm) x 6.0 inches (152.4 mm) outer diameter (12 lb.)	1
	185-101-189+	TUBE, Reservoir, metal, 20 inches (508 mm) x 6.0 inches (152.4 mm) outer diameter (20 lb.)	1
	185-101-190+	TUBE, Reservoir, metal, 8.5 inches (215.9 mm) x 6.0 inches (152.4 mm) outer diameter (6 lb.)	1

Items 2 through 7 are not serviceable by the user; replace entire reservoir.

* Mating fill coupler 506-322-000 (order separately)
 + Reservoir Tube Kit includes gasket (item 9).

Table 2-2. Grease Reservoir Parts List - Continued

Item Number	Part Number	Description	Quantity
20	439-060-181	GASKET, Top Vent (3 lb.)	1
21		BUSHING, Follower	1
22		WASHER, Follower	1
23		WASHER, Support	1
24		NUT, Jam, 3/4-16	1
25		O-RING	1
26		RING, Retaining	1
27	527-000-230	PLUG, Low Level (3 lb.)	1
28	527-000-240	GASKET (3 lb.)	1

Items 21 through 26 are not serviceable by the user; replace entire reservoir.

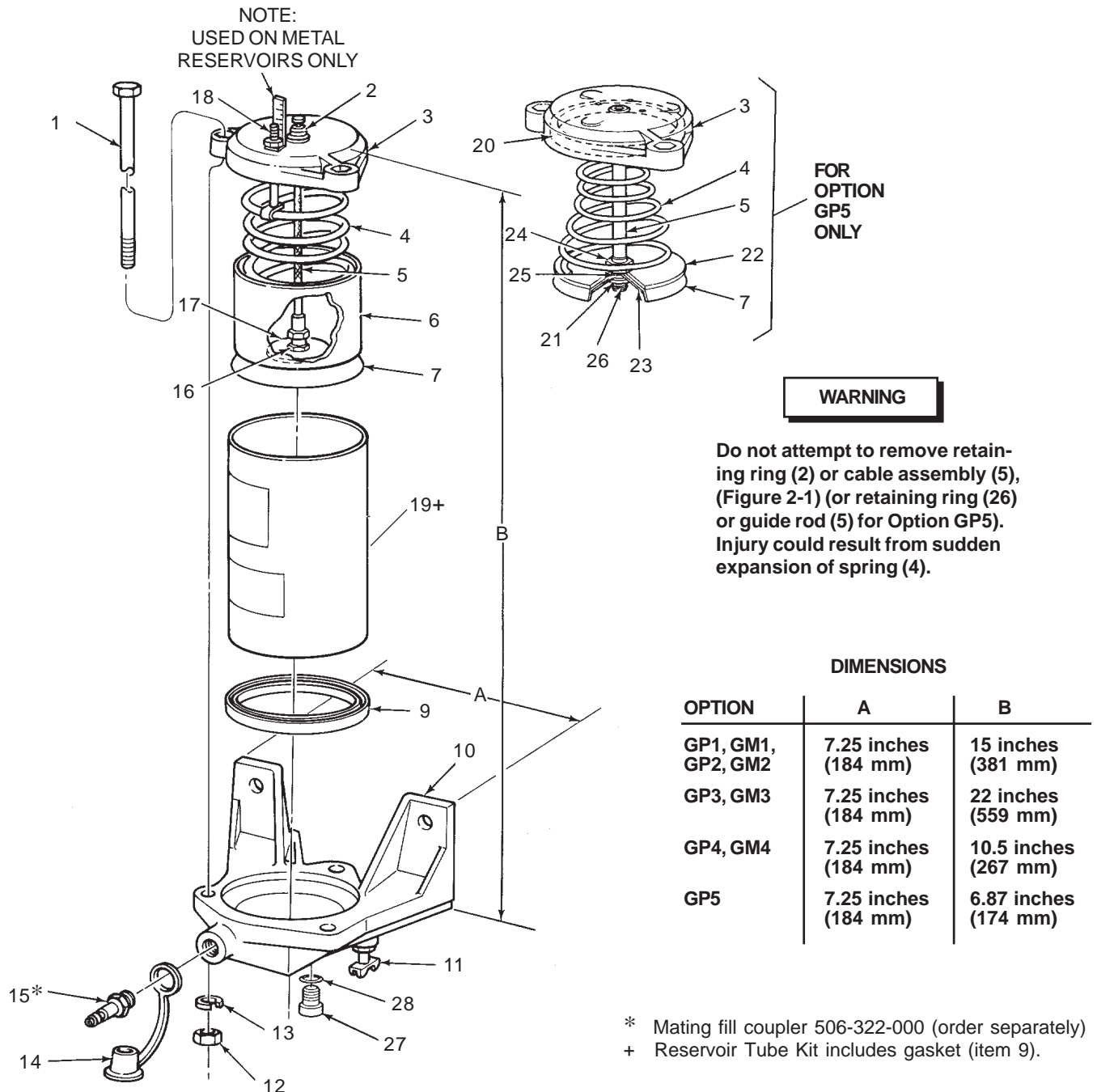

Figure 2-1. Grease Reservoir - Exploded View

2.5 OIL RESERVOIR MAINTENANCE (OPTIONS OP1 THROUGH OP4)

2.5.1 General. Maintenance tips, disassembly, and assembly procedures for oil reservoirs are discussed in Paragraphs 2.5.2, 2.5.3 and 2.5.4. An exploded view of a typical oil reservoir is shown in Figure 2-2 and should be referred to during the discussion.

2.5.2 Oil Reservoir Maintenance.

2.5.2.1 Maintenance on the oil reservoir consists of the following:

- a. Visually check for oil leakage between reservoir tube (6, Figure 2-2) and base (8). Leakage may indicate that the gasket (7) is defective or that nuts (9) are not tight. Torque nuts (9) to 5 ft lbs. If leakage continues, replace gasket (7). Check for cracks and nicks on tube (6). Replace the tube as required.
- b. Visually check screen (2) in fill cup (3) to make sure it is not clogged. If necessary, remove the screen for cleaning.
- c. Check reservoir bottom for debris. Clean as required.

WARNING

Disconnect and lock out power before opening electrical enclosures or conduit connections. Serious injury may result from electrical shock.

2.5.3 Disassembly of Oil Reservoir. Figure 2-2 shows a typical oil reservoir but does not include other Modu-Flo components which may be mounted to the reservoir. These components include the manifold, pump, level switches and high-pressure blowout switches. Disassembly of the reservoir may require that some of these components be removed. The manifold and pump do not normally require removal, but may be removed if desired. The level and blow-out switches may or may not require removal, depending on the level of disassembly required. The electrical connections to the switches should be disconnected in order to remove various parts without restriction of movement by the electrical cord. The removal of these components is explained in other sections of the manual. Refer to the table of contents to find where the components are discussed.

2.5.3.1 The disassembly procedure may be performed with the reservoir mounted to the mounting surface. However, some mounting locations may be too restrictive to provide access to all components. If your particular installation requires dismounting of the reservoir, make sure the reservoir

is drained of lubricant before removing the attaching hardware. This will reduce the weight of the reservoir and reduce the chance of spillage. The disassembly procedure is as follows:

- a. Remove pipe plug (4, Figure 2-2) from base (8) and allow oil to drain from reservoir into bucket or similar container. Properly dispose of emptied oil.
- b. Remove three hex nuts (9) and three lockwashers (10) from tie rods (1). Remove tie rods (1) from reservoir cap (5).
- c. Remove reservoir cap (5) from reservoir tube (6).
- d. Remove fill screen (2) from fill cup (3) and clean screen.
- e. Remove reservoir tube (6) from base (8).
- f. Remove and discard gasket (7) from reservoir tube (6).

2.5.4 Assembly of Oil Reservoir.

NOTE

Before assembly, lubricate followers and tube inner diameter with the lubricant which is used in the system.

2.5.4.1 Assemble the oil reservoir according to the following procedure:

- a. Install screen (2, Figure 2-2) in fill cup (3).
- b. Install new gasket (7) on reservoir tube (6).
- c. Position reservoir tube (6) on base (8) and position reservoir cap (5) on tube.
- d. Rotate reservoir cap (5) until tie rods (1) can be installed through holes in cap and in base (8). The heads of tie rods (1) must fit into the hexagon depressions on the upper surface of the reservoir cap (5).
- e. Install lockwashers (10) and hex nuts (9) on tie rods (1). Torque nuts to 5 ft lbs.
- f. Install pipe plug (4) in base (8).

2.5.4.2 When the assembly steps listed in the above paragraph have been completed, any Modu-Flo components which were removed to ease disassembly should be reinstalled on the reservoir.

2.5.5 Oil Reservoir Parts Lists. Table 2-3 identifies the parts indexed in Figure 2-2.

Table 2-3. Oil Reservoir Parts Lists

Item Number	Part Number	Description	Quantity
	185-100-080	RESERVOIR ASSEMBLY, 5 pint (2.37 liters), plastic (OP1)	--
	185-100-060	RESERVOIR ASSEMBLY, 12 pint (5.68 liters), plastic (OP2)	--
	185-100-070	RESERVOIR ASSEMBLY, 20 pint (9.46 liters), plastic (OP3)	--
	185-100-750	RESERVOIR ASSEMBLY, 6 pint (2.84 liters), plastic (OP4)	--
1	415-700-272	BOLT, Tie (5 pint, 12 pint)	3
	415-700-273	BOLT, Tie (6 pint)	3
	415-700-271	BOLT, Tie (20 pint)	3
2	534-304-003	SCREEN (40 Mesh)	1
3	534-147-000	CUP, Fill	1
4	508-975-000	PLUG, Pipe, 1/4 inch NPT	3
5	521-000-600	CAP, Reservoir (4" Tube) (5 pint)	1
	501-474-029	CAP, Reservoir (6" Tube) (6,12, 20 pint)	1
6	185-100-720+	TUBE, Reservoir, 13 inches (330.2 mm) x 4 inches 1 (100 mm) outer diameter (5 pint)	
	185-100-990+	TUBE, Reservoir, 8.5 inches (215.9 mm) x 6.0 inches (152.4 mm) outer diameter (6 pint)	1
	185-100-730+	TUBE, Reservoir, 13 inches (330.2 mm) x 6.0 inches (152.4 mm) outer diameter (12 pint)	1
	185-100-740+	TUBE, Reservoir, 20 inches (508 mm) x 6.0 inches (152.4 mm) outer diameter (20 pint)	
7	501-414-000	GASKET (4" Tube) (5 pint)	1
	501-423-001	GASKET (6" Tube) (6, 12, 20 pint)	1
8	521-000-530	BASE (4" Tube) (5 pint)	1
	521-000-500	BASE (6" Tube) (6, 12, 20 pint)	1
9	410-040-020	NUT, Hexagon, 5/16-18	3
10	421-010-020	LOCKWASHER, 5/16 inch	3

+ Reservoir Tube Kit includes gasket (Item 7).

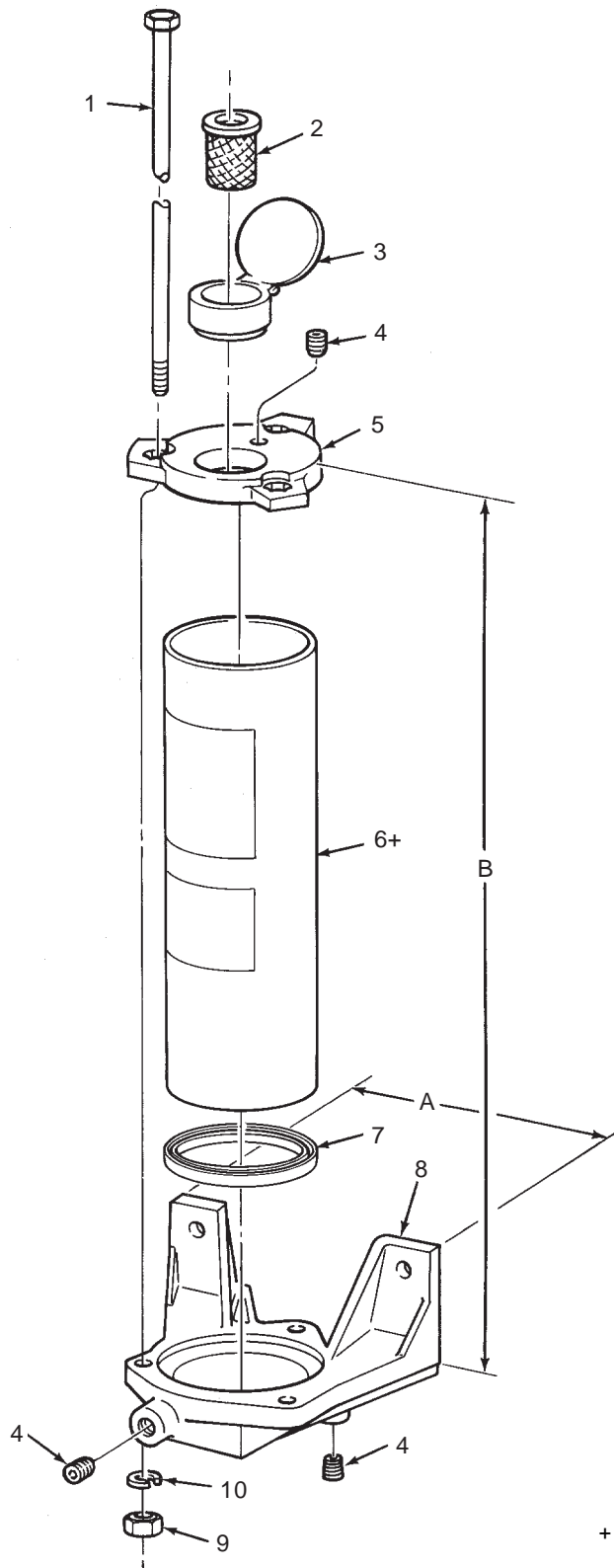

DIMENSIONS

OPTION	A	B
OP1, OP2	7.25 inches (184 mm)	15 inches (381 mm)
OP3	7.25 inches (184 mm)	22 inches (559 mm)
OP4	7.25 inches (184 mm)	10.5 inches (267 mm)

+ Reservoir Tube Kit includes gasket (Item 7).

Figure 2-2. Oil Reservoir - Exploded View

2.6 OIL TANK MAINTENANCE (OPTIONS T1, T2 and T3)

2.6.1 General. Maintenance tips, disassembly and assembly procedures for oil tanks are discussed in Paragraphs 2.6.2, 2.6.3 and 2.6.4. An exploded view of a typical oil tank is shown in Figure 2-3 and should be referred to during the discussion.

2.6.2 Oil Tank Maintenance.

2.6.2.1 Maintenance on the oil tanks consists of the following:

- a. Visually check for oil leakage between the tank (9, Figure 2-3), the pump mounting pad (12) and the level sight glass (11). Leakage in either of these areas indicates the components are loose or that gasket (10) or o-ring (13) is defective. The cover (1) will need to be removed to either tighten the components or replace defective seals.
- b. Visually check fill screen (4) to make sure it is not clogged. If necessary, remove the screen for cleaning.
- c. Check that the tank is securely fastened to the wall or supporting structures. Securely tighten any loose attaching hardware.

WARNING

Disconnect and lock out power before opening electrical enclosures or conduit connections. Serious injury may result from electrical shock.

2.6.3 Disassembly of Oil Tanks. Figure 2-3 shows a typical oil tank but does not include other Modu-Flo components which may be mounted to the tank. These components include the manifold, pump, level switches and blow-out switches. Disassembly of tank may require that some of these components be removed. The manifold and pump do not normally require removal, but may be removed if desired. The level and blowout switches may or may not require removal, depending on the level of disassembly required. The electrical connections to the switches should be disconnected in order to remove various parts without restriction of movement by the electrical cord. The removal of these components is explained in other sections of the manual. Refer to the table of contents to find where these components are discussed.

2.6.3.1 The disassembly procedure may be performed with the tank mounted to the mounting surface. However, some mounting locations may be too restrictive to provide access to all components. If your particular installation requires dismantling of the tank, make sure the tank is drained of lubricant before removing the attaching hardware. This will reduce the weight of the tank and reduce the chance of spillage. The disassembly procedure is as follows:

- a. Remove pipe plug (3, Figure 2-3) from base of tank weldment (9) and allow oil to drain into bucket or similar container. Properly dispose of emptied oil.

- b. Remove self-threading screws (2) attaching cover (1) to tank weldment (9) and remove cover and cover gasket (6).
- c. Remove fill screen (4) from fill cup (5) and clean screen.
- d. Remove two screws (7) and aluminum gaskets (8) to release pump mounting pad (12) from tank weldment (9). Remove and discard o-ring (13) from pump mounting pad (12).

NOTE

Step e should be performed only if the sight glass is dirty or leaking. Threads cut on nylon studs of sight glass may prevent the sight glass from being used.

- e. Remove four self-threading nuts (14) and remove sight glass (11) and gasket (10). Discard gasket (10) and sight glass (11).

2.6.4 Assembly of Oil Tanks.

NOTE

Before assembly, lubricate all o-rings with the lubricant which is used in the system.

2.6.4.1 Assemble the oil tanks according to the following procedure:

- a. Install one aluminum gasket (8, Figure 2-3) on each screw (7) and insert threads of screws through holes in bottom of tank weldment (9).
- b. Install new o-ring (13) in pump mounting pad (12) and align threaded holes in pump mounting pad with screws (7) protruding from bottom of tank weldment (9). Thread screws (7) into pump mounting pad (12) until pump mounting pad is snug against bottom of tank weldment (9). Torque screws (7) to 10 ft lbs.
- c. Position new gasket (10) on sight glass (11) and install sight glass on tank weldment (9). Secure sight glass (11) with four self-threading nuts (14).
- d. Install screen (4) into fill cup (5).
- e. Position cover gasket (6) and cover (1) on tank weldment (9) and secure with self-threading screws (2).
- f. Install pipe plug (3) in bottom of tank weldment (9).

2.6.4.2 When the assembly steps listed in the above paragraph have been completed, any Modu-Flo components which were removed to ease disassembly should be reinstalled on the tank.

2.6.5 Oil Tank Parts List. Table 2-4 identifies the parts indexed in Figure 2-3.

Table 2-4. Oil Tank Parts List

Item Number	Part Number	Description	Quantity
	521-001-060	RESERVOIR ASSEMBLY, 12 pint, (5.68 liters) (T1)	--
	521-001-070	RESERVOIR ASSEMBLY, 24 pint, (11.4 liters) (T2)	--
	521-001-080	RESERVOIR ASSEMBLY, 40 pint, (18.9 liters) (T3)	--
1	521-000-810	COVER, (12 pint)	1
	521-000-830	COVER, (24 pint)	1
	521-000-850	COVER, (40 pint)	1
2	415-640-040	SCREW, Self-threading, 1/4-28 x 5/16 inch (12 pint)	6
	415-640-040	SCREW, Self-threading, 1/4-28 x 5/16 inch (24, 40 pint)	8
3	508-975-000	PLUG, Pipe, 1/4 inch NPT	2
4	534-304-003	SCREEN (40 Mesh)	1
5	534-147-000	CUP, Fill	1
6	521-003-420	GASKET, Cover, (12 pint)	1
	521-003-380	GASKET, Cover, (24 pint)	1
	521-003-340	GASKET, Cover, (40 pint)	1
7	419-170-010 *	SCREW, Socket-head, 3/8-16 x 1/2 inch	2
8	439-050-060 *	GASKET, 3/8 stat-o-seal	2
9		WELDMENT, Reservoir	1
		Not available as a item replacement	
10	439-060-110	GASKET	1
11	438-028-283	SIGHT GLASS	1
12	521-000-921 *	PAD, Pump mounting	1
13	423-700-096 *	O-RING	1
14	410-701-986	NUT, Self-threading	4
15	421-010-010	Lockwasher, 1/4 inch (12 pint)	6
	421-010-010	Lockwasher, 1/4 inch (24, 40 pint)	8
16	412-150-040+	Plug, 3/8 NPT	1

* Reservoirs with separate aluminum pump mounting pads only. Steel pump mounting pads are welded in place and are not replaceable.

+ Used on reservoirs with front pressure-fill port only.

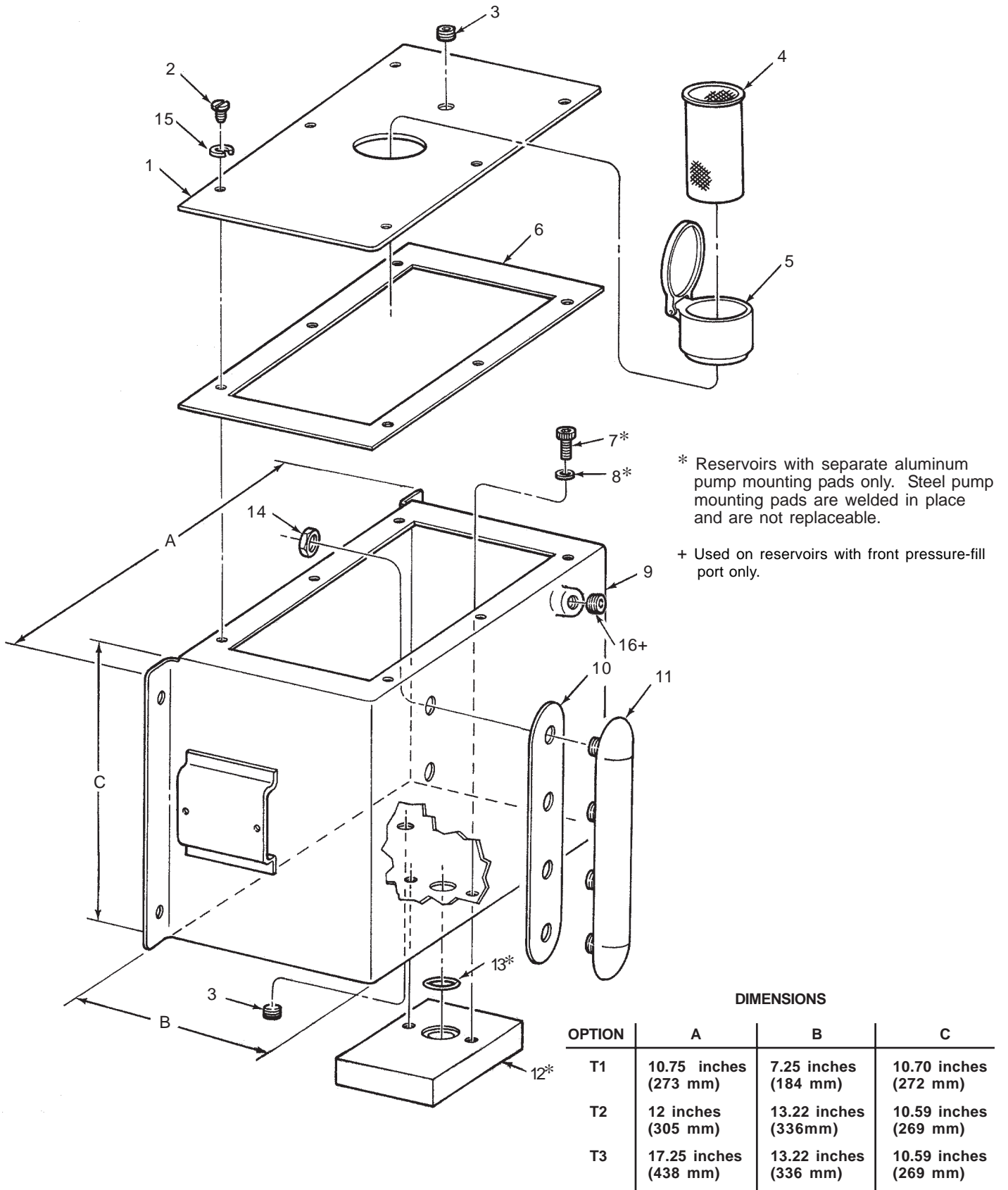

Figure 2-3. Oil Tank - Exploded View

OPERATION AND SERVICE INSTRUCTIONS

Modu-Flo® System

SECTION 3

PUMPS

3.1 DESCRIPTION	3-1	3.4.3 Disassembly of Hydraulic Pump Options H1 and H3	3-9
3.1.1 General	3-1	3.4.4 Assembly of Hydraulic Pump Options H1 and H3	3-9
3.2 PREPARATION FOR USE	3-3	3.4.5 Hydraulic Pump Options H1 and H3 Parts List	3-10
3.2.1 Mounting	3-3	3.5 HYDRAULIC PUMP MAINTENANCE (OPTION H2)	3-13
3.2.2 Output Adjustment	3-3	3.5.1 General	3-13
3.3 PNEUMATIC PUMP MAINTENANCE (OPTIONS A1 THROUGH A6)	3-3	3.5.2 Hydraulic Pump Option H2 Maintenance Tips	3-13
3.3.1 General	3-3	3.5.3 Disassembly of Hydraulic Pump Option H2	3-13
3.3.2 Pneumatic Pump Maintenance Tips	3-3	3.5.4 Assembly of Hydraulic Pump Option H2	3-13
3.3.3 Disassembly of Pneumatic Pump	3-3	3.5.5 Hydraulic Pump Option H2 Parts List	3-14
3.3.4 Assembly of Pneumatic Pump	3-4		
3.3.5 Pneumatic Pump Parts List	3-4		
3.4 HYDRAULIC PUMP MAINTENANCE (OPTIONS H1 and H3)	3-9		
3.4.1 General	3-9		
3.4.2 Hydraulic Pump Options H1 and H3 Maintenance Tips	3-9		

3.1 DESCRIPTION

3.1.1 General. There are six models available for use. Three models are pneumatically operated and three are hydraulically operated. The pneumatic models may be single or double acting. An internal spring will return the piston to the reload position in single-acting pumps. All hydraulic models are double-acting.

3.1.1.1 All models are designed to mount directly to either the pump-to-reservoir manifold or the pump-to-wall manifold. When the pump is properly mounted on a manifold, the manifold will have all the porting for air and lubricant connections to and from the pump.

3.1.1.2 Operating sequences for single-acting and double-acting pumps are listed below. Figure 3-1 shows a sectional view of a typical pump and will help in understanding pump operation.

a. With single-acting models, air under pressure is supplied through the inlet port (SA) to chamber (C). This moves the air and lube pistons to the right. This closes the lube inlet port and forces the lubricant already in chamber (B) past the check valve and into the system. Air in chamber (A) must vent out port (DA). A plastic pipe plug with a vent hole is installed in port (DA). After a preset time interval the solenoid valve shuts off the air supply and vents chamber (C) through port (SA). The spring returns the air and lube pistons, opening chamber (B) to the lube reservoir. This completes a

single pump cycle and chamber (B) is primed, ready for the next cycle.

b. The double-acting models have an additional air or hydraulic supply line connected to port (DA). When the pistons have been moved to the right, air or hydraulic supply to port (SA) is shut off and vented. Then, air or hydraulic fluid under pressure is supplied to port (DA), which returns the pistons to their original position. This more powerful return action allows an increased cycle rate of the pump.

3.1.1.3 All pneumatic pumps have a lube-to-air pressure ratio of 30:1. The pumps operate on input pressure ranging from 40 to 150 psi (3 to 10 bar). The HLJ-5M and HLJ-25M hydraulic pumps have a lube-to-hydraulic ratio of 5.5:1. The HLJ-5X has a lube-to-hydraulic ratio of 2.2:1. The hydraulic pumps operate on input pressures ranging from 200 to 2000 psi (14 to 138 bar). It should be noted that lower input pressures may prevent the pumps from building sufficient pressure to crack a rupture disc or activate a high-pressure device. In pneumatic systems, with an inlet air pressure of 40 psi (3 bar), only 1200 psi (83 bar) could be developed. In hydraulic systems, with 200 psi (14 bar) only 1100 psi (76 bar) could be developed. Neither of these pressures would be high enough to crack a 1450 psi disc. The system could be blocked and not functioning without giving any indication to plant personnel. The supply pressure, either pneumatic or hydraulic, should be adjusted high enough to ensure that a blocked line will cause sufficient pressure to be developed.

3.1.1.4 In pneumatically-operated systems, pressure surges often occur when the solenoid is energized. These surges can be minimized by installing air flow devices in the solenoid pneumatic lines.

3.1.1.5 Table 3-1 lists the available pumps along with other data. Note that the part number on the pneumatic pump is the same for two different pump models. This is because any pneumatic pump may be used as either single- or

double-acting. Listings in the option column are used to identify the pump selected when a Modu-Flo system is ordered. The option used is designated by the entry in the ordering code as shown below:

MPP - XXX - XXX - XX - XX - XX - XX - XXX - XX
 |
 Pump Option

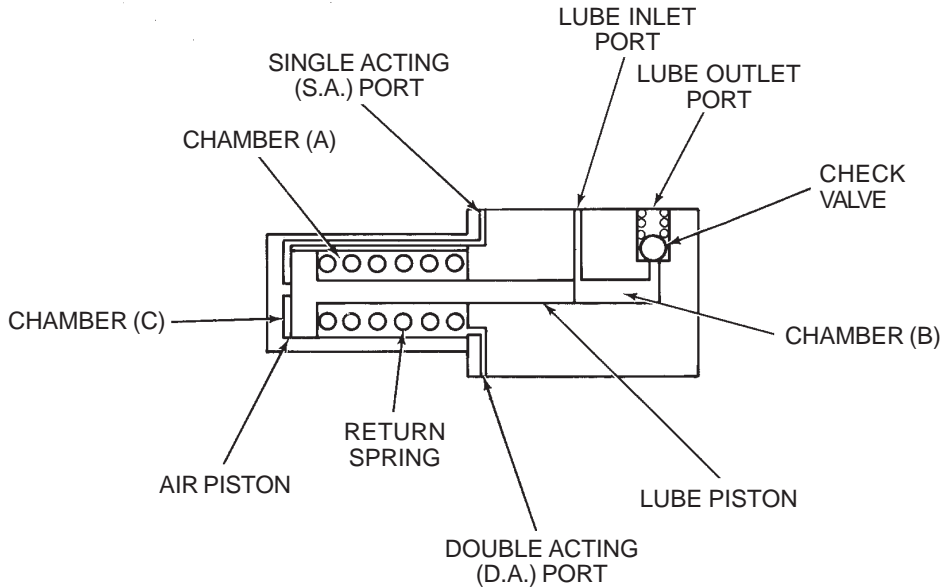

Figure 3-1. Typical Pump Operation

Table 3-1. Pumps

Part Number	Model	Action	Output Displacement Range cu in (cm ³) per stroke	Maximum Strokes/ Minute	Input Volume Per Full Stroke/Cycle cu.in. (cm ³)	Option
A. Pneumatic Pumps						
521-000-001	AL-5	Single Double	0.010 to 0.030 (0.164 to 0.492)	65 100	1.06 (17.4) 2.09 (34.3)	A1
521-000-021	AL-25	Single Double	0.030 to 0.120 (0.492 to 1.966)	25 100	4.20 (68.8) 8.28 (135.7)	A3
521-000-041	AL-50	Single Double	0.060 to 0.240 (0.983 to 3.933)	20 60	8.40 (137.6) 16.56 (271.4)	A5
B. Hydraulic Pumps						
521-000-011	HLJ-5	Double	0.010 to 0.030 (0.164 to 0.492)	100	0.35 (5.7)	H1
521-000-031	HLJ-25	Double	0.030 to 0.120 (0.492 to 1.966)	50	1.38 (22.6)	H2
521-005-900	HLJ-5X	Double	0.030 to 0.092 (0.492 to 1.51)	100	1.28 (21.0)	H3

3.2 PREPARATION FOR USE

3.2.1 Mounting. Any pump mounts directly to any manifold with four socket-head capscrews. Care must be taken to ensure that the outlet of the manifold is lined up with the inlet on the pump. The face of the pump which mates with the manifold has several o-rings. When the pump is being installed, care must be taken to ensure these o-rings are not moved out of position. The o-rings provide a seal for the movement of air and lubricant between the manifold and pump. If an o-ring is missing, air or lubricant may leak. After being secured to the manifold, no further connections can be made to the pump.

3.2.2 Output Adjustment. Adjustment of the pump output may be made with the pump removed from or still attached to the manifold.

3.2.2.1 The procedure for output adjustment is listed below. The items referenced are found in Figure 3-2. The adjustment procedure is the same for both pneumatic and hydraulic pumps.

- a. Remove adjustment cap (22) from adjustment screw (13), holding jam nut (21) if necessary.
- b. Butt adjustment cap (22) against jam nut (21) and use the stamped numbers on the cap to determine how much adjustment is needed.
- c. Loosen jam nut (21) and use a flat screwdriver to turn adjustment screw (13). Turn adjustment screw in for less output, turn out for more output.
- d. Tighten jam nut (21) and install adjustment cap (22) over the adjustment screw (13).

3.2.2.2 When adjusting pump output, one complete turn of the adjusting screw will change the output by the following amounts:

- a. 0.0018 cubic inch for pump options A1 and A2.
- b. 0.006 cubic inch for pump options A3 and A4.
- c. 0.009 cubic inch for pump options A5 and A6.
- d. 0.0018 cubic inch for pump option H1.
- e. 0.006 cubic inch for pump option H2 and H3.

3.3 PNEUMATIC PUMP MAINTENANCE (OPTIONS A1 THROUGH A6)

3.3.1 General. Maintenance tips, disassembly and assembly procedures for pneumatic pumps are discussed in Paragraphs 3.3.2 through 3.3.4. An exploded view of a typical pneumatic pump is shown in Figure 3-2 and should be referred to during the discussion.

3.3.2 Pneumatic Pump Maintenance Tips.

3.3.2.1 The only maintenance required on the pneumatic pump is to check for the following:

- a. Check four socket-head screws (11, Figure 3-2) to make sure they are tight. Loose screws could allow air and/or lubricant to leak between the pump and the manifold. This condition could result in erratic pump output.

- b. Check jam nut (21) to make sure it is tight against adjustment screw body (19). If the jam nut is loose, the adjustment screw (13) could rotate and cause the pump output to change. This condition could also result in lubricant leakage or in air being sucked into the lubricant.

3.3.2.2 If internal components of the pump are defective it will usually result in erratic pump operation or output. Section 9 of this manual lists causes and solutions for problems which could occur in the Modu-Flo system. Before disassembling any pump, refer to Section 10. The problem may be caused by other conditions which can be checked first before disassembling the pump.

3.3.3 Disassembly of Pneumatic Pump. The procedure below describes complete disassembly of a pump. However, you only need to disassemble to your specific area of concern.

3.3.3.1 The disassembly procedure for the pneumatic pump is as follows:

NOTE

Figure 3-2 shows air cylinder (7) separated from pump body (10). To achieve disassembly to this level requires special tools to remove air cylinder retainer (23). Normally, this level of disassembly is only performed at the factory. If scoring or wear marks are evident on the inner diameter of air cylinder (7) or pump body (10), the pump assembly cannot be serviced and should be replaced.

- a. Separate pump from manifold by removing four socket-head screws (11, Figure 3-2). Remove and discard three o-rings (9) and one o-ring (18).
- b. Remove enclosure screw (14). Remove and discard gasket (15). Remove check valve spring (16), ball (32), and check seat (29). Remove and discard o-ring (30) from seat (29).
- c. Remove adjustment screw body (19) and o-ring (12) from pump body (10). Discard o-ring (12). Removal of adjustment screw (13) from adjustment screw body (19) will change output setting when pump is reassembled. If adjustment screw (13) requires removal, perform the following:
 - (1) Remove adjustment screw cap (22) from adjustment screw (13). Butt the adjustment screw cap (22) against jam nut (21) and use the stamped numbers on the cap to measure how far the adjustment screw (13) extends from the jam nut. Record this dimension.
 - (2) Remove jam nut (21) and two gaskets (20). Discard gaskets.
 - (3) Remove adjustment screw (13) by screwing it towards the hex portion of the adjustment screw body (19) until it is free.
- d. Remove retainer ring (4).

- e. Insert wooden dowel or soft rod into pump body (10) and push lube piston (5) until cylinder cap (3) is out of air cylinder (7). Remove and discard o-ring (2) from cylinder cap (3).
- f. Continue to push lube piston (5) through pump body (10) until air piston (1) is exposed and can be removed from air cylinder (7). Remove air piston (1), lube piston (5), and piston-return spring (24) from air cylinder (7).
- g. Remove retainer ring (25) and spring retainer (26) from air piston (1).
- h. Remove retainer ring (27) to separate lube piston (5) from air piston (1). Remove and discard o-rings (6 and 28).

3.3.4 Assembly of Pneumatic Pump.

3.3.4.1 Assemble the pneumatic pump according to the following procedure:

NOTE

Use new o-rings, gaskets and return spring when assembling pump. Lubricate all o-rings and sliding parts with the lubricant which is used in the system.

- a. Install new o-ring (6) on lube piston (5).
- b. Install new o-ring (28) on air piston (1). Install lube piston (5) into air piston (1) and secure with retainer ring (27).
- c. Install spring retainer (26) in air piston (1) and secure with retainer ring (25).
- d. Install piston-return spring (24) in air cylinder (7). Push air piston (1) through air cylinder (7) and into pump body (10).
- e. Install new o-ring (2) on cylinder cap (3) and secure in air cylinder (7) with retainer ring (4).
- f. Insert smaller end of adjustment screw (13) into adjustment screw body (19). Rotate adjustment screw (13) until smaller end is protruding from hex portion of adjustment screw body (19).
- g. Install new o-ring (12) on adjustment screw body (19) and install adjustment screw body in pump body (10). Tighten securely.
- h. Install jam nut (21) and two new gaskets (20), one on each side of jam nut, on adjustment screw (13). Butt adjustment screw cap (22) against jam nut (21) and turn adjustment screw (13) until the length it extends beyond the jam nut is the same as the length recorded during disassembly.
- i. Install adjustment screw cap (22) on adjustment screw (13).
- j. Install new o-ring (30) on check seat (29) and install seat into pump body.
- k. Install steel ball (32) and check valve spring (16) into pump body (10). Place new gasket (15) on enclosure screw (14). Install enclosure screw (14) into pump body (10) and tighten securely.
- l. Install three new o-rings (9) and one new o-ring (18) into pump body (10). Securely attach to manifold with four socket-head screws (11).

3.3.4.2 When the assembly steps listed above have been completed, adjust the pump output as described in Paragraph 3.2.2.

3.3.5 **Pneumatic Pump Parts List.** Table 3-2 identifies the parts indexed in Figure 3-2.

Table 3-2. Pneumatic Pump Parts List

Item Number	Part Number	Description	Quantity
	521-000-001	PUMP ASSEMBLY (AL5)	--
	521-000-021	PUMP ASSEMBLY (AL25)	--
	521-000-041	PUMP ASSEMBLY (AL50)	--
1	521-000-110	PISTON, Air (AL5)	1
	521-000-220	PISTON, Air (AL25)	1
	521-000-400	PISTON, Air (AL50)	1
2	422-010-290+	O-RING, Part of kit 560-001-021 (AL5)	1
	422-010-350+	O-RING, Part of kit 560-001-031 (AL25)	1
	422-010-380+	O-RING, Part of kit 560-001-041 (AL50)	1
3	521-000-100	CAP, Cylinder (AL5)	1
	521-000-210	CAP, Cylinder (AL25)	1
	521-000-390	CAP, Cylinder (AL50)	1
4	418-050-310+	RING, Retainer, part of kit 560-001-021 (AL5)	1
	418-050-450+	RING, Retainer, part of kit 560-001-031 (AL25)	1
	418-050-520+	RING, Retainer, part of kit 560-001-041 (AL50)	1
5 *		PISTON, Lube	1
6	527-000-790+	O-RING, Part of kit 560-001-021 (AL5)	1
	423-700-111+	O-RING, Part of kit 560-001-031 (AL25)	1
	423-700-112+	O-RING, Part of kit 560-001-041 (AL50)	1
7	521-000-080	CYLINDER, Air (AL5)	1
	521-000-200	CYLINDER, Air (AL25)	1
	521-000-450	CYLINDER, Air (AL50)	1
8	422-010-200+	O-RING, Part of kits 560-001-021, 560-001-031 and 560-001-041	1
9	423-700-113+	O-RING, Part of kits 560-001-021, 560-001-031 and 560-001-041	5
10 *		BODY, Pump	1
11	419-130-070+	SCREW, Socket-head, 1/4-20 x 1-1/4 inch	4
12	422-011-140+	O-RING, Part of kits 560-001-021, 560-001-031 and 560-001-041	1
13	521-003-000	SCREW, Adjustment (AL5)	1
	521-003-010	SCREW, Adjustment (AL25)	1
	521-003-020	SCREW, Adjustment (AL50)	1
14	521-008-460	SCREW, Enclosure	1
15	500-132-000+	GASKET, Part of kits 560-001-021, 560-001-031 and 560-001-041	1
16	511-893-000+	SPRING, Check valve, part of kits 560-001-021, 560-001-031 and 560-001-041	1
17	401-030-030+	BALL, Steel, 3/16 inch diameter, part of kits 560-001-021, 560-001-031 and 560-001-041	1
18	423-700-114+	O-RING, Part of kit 560-001-021, 560-001-031, 560-001-041	1
19	521-003-030	BODY, Adjustment screw (AL5)	1
	521-003-040	BODY, Adjustment screw (AL25)	1
	521-003-050	BODY, Adjustment screw (AL50)	1
20	439-040-050+	GASKET, Part of kit 560-001-021 (AL5)	2
	439-040-070+	GASKET, Part of kit 560-001-031 (AL25)	2
	439-040-080+	GASKET, Part of kit 560-001-041 (AL50)	2
21	410-702-028+	NUT, Jam, hexagon, 5/16-24 (AL5)	1
	410-702-033+	NUT, Jam, hexagon, 7/16-20 (AL25)	1
	410-702-034+	NUT, Jam, hexagon, 1/2-20 (AL50)	1
22	521-002-970	CAP, Adjustment screw (AL5)	1
	521-002-980	CAP, Adjustment screw (AL25)	1
	521-002-990	CAP, Adjustment screw (AL50)	1
23	521-000-150	RETAINER, Air cylinder	1
24	521-000-070+	SPRING, Piston return, part of kit 560-001-021 (AL5)	1
	521-000-480+	SPRING, Piston return, part of kit 560-001-031 (AL25)	1
	521-000-420+	SPRING, Piston return, part of kit 560-001-041 (AL50)	1
25	418-050-110+	RING, Retainer, part of kit 560-001-021 (AL5)	1
	418-050-160+	RING, Retainer, part of kits 560-001-031 and 560-001-041 (AL25 AL50)	1
26	521-000-520	RETAINER, Spring (AL5)	1
	521-000-510	RETAINER, Spring (AL25)	1
	521-000-430	RETAINER, Spring (AL50)	1

+ Included in Repair Kit. Refer to Page 3-6

* Not Available as Replacement Parts.

Table 3-2. Pneumatic Pump Parts List - Continued

Item Number	Part Number	Description	Quantity
27	418-150-050+	RING, Retainer, part of kit 560-001-021 (AL5)	1
	418-150-070+	RING, Retainer, part of kit 560-001-031 (AL25)	1
	418-150-080+	RING, Retainer, part of kit 560-001-041 (AL50)	1
28	423-700-118+	O-RING, Part of kit 560-001-021 (AL5)	1
	423-700-119+	O-RING, Part of kit 560-001-031 (AL25)	1
	423-700-120+	O-RING, Part of kit 560-001-041 (AL50)	1
29	521-008-450+	SEAT, Check valve, part of kits 560-001-021, 560-001-031, and 560-001-041	1
30	422-010-080+	O-RING, Part of kits 560-001-021, 560-001-031, and 560-001-041	1
33	521-000-050	SCREW, Enclosure	1
34	401-010-010+	BALL, Steel 1/8" Dia.	1
35	417-450-020+	SCREW, Set 10-32"x1/4"	1
36	411-700-763+	ROLL PIN	1
--	560-001-021	REPAIR KIT (consists of Items 2, 4, 6, 8, 9, 11, 12, 15 thru 18, 20, 21, 24, 25, 27 thru 30 and 34 thru 36) (AL5)	1
	560-001-031	REPAIR KIT (consists of Items 2, 4, 6, 8, 9, 11, 12, 15 thru 18, 20, 21, 24, 25, 27 thru 30 and 34 thru 36) (AL25)	1
	560-001-041	REPAIR KIT (consists of Items 2, 4, 6, 8, 9, 11, 12, 15 thru 18, 20, 21, 24, 25, 27 thru 30 and 34 thru 36) (AL50)	1
--	521-001-391	PUMP ADJUSTMENT ASSEMBLY (consists of Items 13 and 19 thru 22) (AL5)	1
--	521-001-401	PUMP ADJUSTMENT ASSEMBLY (consists of Items 13 and 19 thru 22) (AL25)	1
--	521-001-411	PUMP ADJUSTMENT ASSEMBLY (consists of Items 13 and 19 thru 22) (AL50)	1

+ Included in Repair Kit. Refer to Repair Kits above.

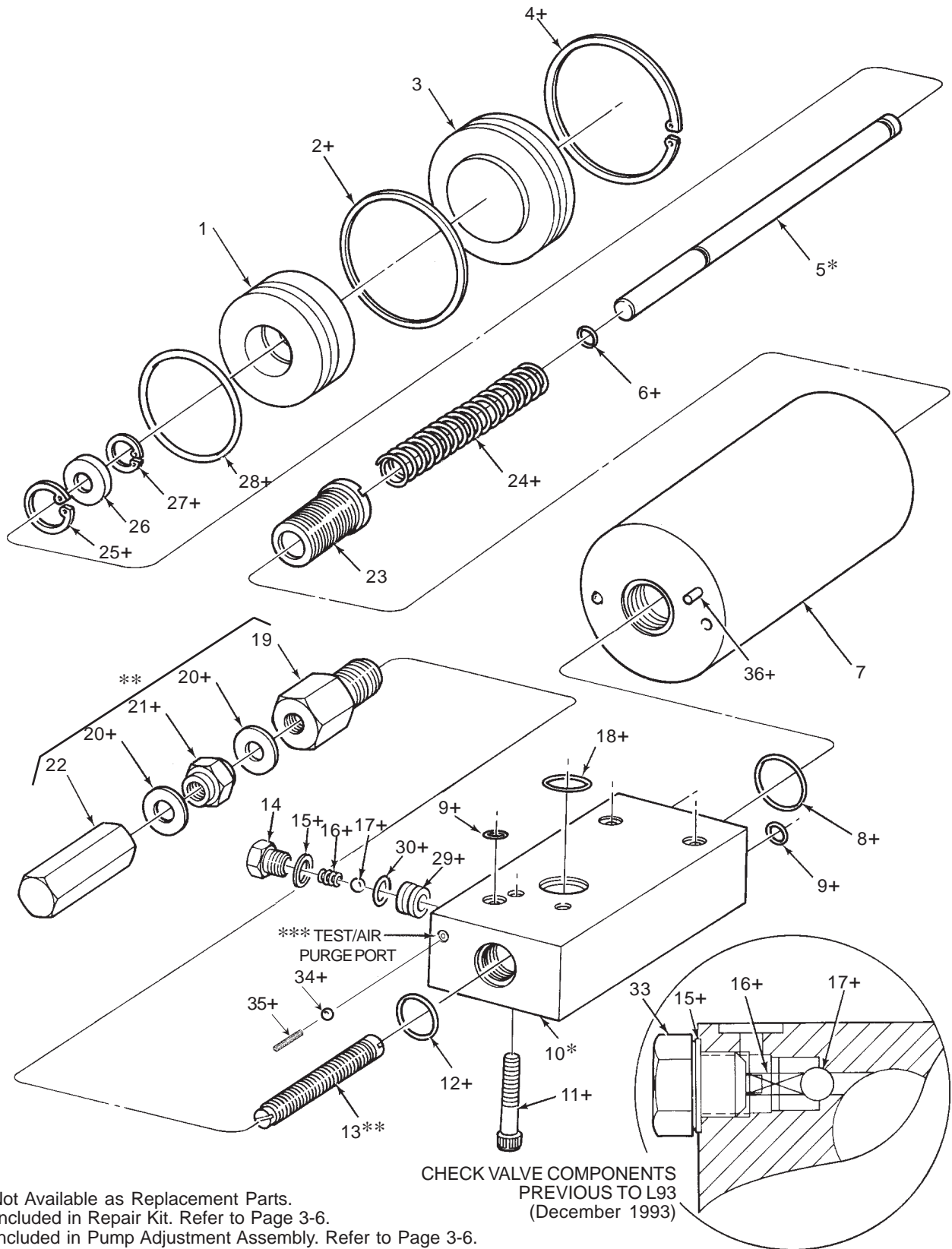

Figure 3-2. Pneumatic Pump, Exploded View

3.4 HYDRAULIC PUMP MAINTENANCE (OPTIONS H1 and H3)

3.4.1 General. Maintenance tips, disassembly and assembly procedures for Options H1 and H3 hydraulic pump are discussed in Paragraphs 3.4.2 through 3.4.4. An exploded view of the pump is shown in Figure 3-3 and should be referred to during the discussion.

3.4.2 Hydraulic Pump Options H1 and H3 Maintenance Tips.

3.4.2.1 The only maintenance required on the hydraulic pump Options H1 and H3 is to check for the following:

- a. Check four socket-head screws (8, Figure 3-3) to make sure they are tight. Loose screws could allow hydraulic fluid and/or lubricant to leak between the pump and the manifold. This condition could result in erratic pump output.
- b. Check for leakage past gasket (12). Replace gasket if required.
- c. Check jam nut (19) to make sure that it is tight against adjustment screw body (17). If the jam nut is loose, the adjustment screw (10) could rotate and cause the pump output to change. This condition could also result in lubricant leakage or in air being sucked into the lubricant.

3.4.2.2 If internal components of the pump are defective it will usually result in erratic pump operation or output. Section 10 of this manual lists causes and solutions for problems which could occur in the Modu-Flo system. Before disassembling any pump, refer to Section 10. The problem may be caused by other conditions which can be checked first before disassembling the pump.

3.4.3 Disassembly of Hydraulic Pump Options H1 and H3. The procedure below describes complete disassembly of a pump. However, you only need to disassemble to your specific area of concern.

3.4.3.1 The disassembly procedure for the hydraulic pump Options H1 and H3 is as follows:

- a. Separate pump from manifold by removing four socket-head screws (8). Remove and discard three o-rings (15) and one o-ring (16).
- b. Remove enclosure screw (11). Remove and discard gasket (12), check valve spring (13), steel ball (24), check seat (22), and o-ring (23).
- c. Remove adjustment screw body (17) and o-ring (9) from body (7). Discard o-ring (9). Removal of adjustment screw (10) from adjustment screw body (17) will change output setting when pump is reassembled. If adjustment screw (10) requires removal, perform the following:
 - (1) Remove adjustment screw cap (20) from adjustment screw (10). Butt the adjustment screw cap (20) against jam nut (19) and use the stamped numbers on the cap to measure how far the adjustment screw (10) extends from the jam nut. Record this dimension.

(2) Remove jam nut (19) and two gaskets (18). Discard gaskets (18).

(3) Remove adjustment screw (10) by screwing it towards the hex portion of the adjustment screw body (17) until it is free.

d. Remove cylinder cap (6) from body (7). Remove and discard o-ring (5).

e. Removal of the piston and its associated components is different for each option. Perform the appropriate following steps:

(1) For Option H1, use a wood dowel or a soft rod to push hydraulic piston (2) and lube piston (1) from pump body (7). Remove and discard o-rings (4) and (21). Inspect piston (2) and pump body (7) inner diameter for scoring or wear marks. If damage is present the pump assembly cannot be serviced and should be replaced.

(2) For Option H3, use a wood dowel or a soft rod to push the piston (27) from the pump body (7). Remove and discard o-rings (26 and 29) and backup rings (25 and 28). Inspect piston (27) and pump body (7) inner diameter for scoring or wear marks. If damage is present, the pump assembly cannot be serviced and should be replaced.

f. For the H1 option only, separate hydraulic piston (2) and lube piston (1) by removing groove pin (3).

3.4.4 Assembly of Hydraulic Pump Options H1 and H3.

NOTE

Use new o-rings and gaskets when assembling pump. Lubricate all o-rings and sliding parts with the lubricant which is used in the system.

3.4.4.1 Assemble the hydraulic pump Options H1 and H3 according to the following procedure:

a. For the H1 option only, insert lube piston (1) into hydraulic piston (2). Install groove pin (3) to secure the assembly.

b. Assembly of the piston and its associated components is different for each option. Perform the appropriate following steps:

(1) For Option H1, install new o-ring (4) on hydraulic piston (2). Install new o-ring (21) on lube piston (1). Insert pistons into body (7).

(2) For Option H3, install new o-ring (26) and backup rings (25) on cylinder cap end of piston (27). Install new o-ring (29) and backup rings (28) on the other end of the piston (27).

c. Install new o-ring (5) on cylinder cap (6). Screw cylinder cap (6) into body (7) and securely tighten it.

d. Insert smaller end of adjustment screw (10) into adjustment screw body (17). Rotate adjustment screw (10) until smaller end is protruding from hex portion of adjustment screw body (17).

e. Install new o-ring (9) on adjustment screw body (17) and install adjustment screw body in body (7). Tighten securely.

- f. Install jam nut (19) and two new gaskets (18), one on each side of jam nut, on adjustment screw (10). Butt adjustment screw cap (20) against jam nut (19) and turn adjustment screw (10) until the length it extends beyond the jam nut is the same as the length recorded during disassembly.
- g. Install adjustment screw cap (20) on adjustment screw (10).
- h. Install new o-ring (23) on check seat (22) and install seat assembly into pump body.
- i. Install steel ball (24) and check valve spring (13) into

- body (7). Place new gasket (12) on enclosure screw (11). Screw enclosure screw into body (7) and tighten securely.
- j. Install three new o-rings (15) and one o-ring (16) into body (7). Securely attach pump assembly to manifold with four socket-head screws (8).

3.4.4.2 When the assembly steps listed above have been completed, adjust the pump output as described in Paragraph 3.2.2.

3.4.5 Hydraulic Pump Options H1 and H3 Parts List. Table 3-3 identifies the parts indexed in Figure 3-3.

Table 3-3. Hydraulic Pump Options H1 and H3 Parts List

Item Number	Part Number	Description	Quantity
	521-000-011	PUMP ASSEMBLY, HLJ-5 (Option H1)	--
	521-005-900	PUMP ASSEMBLY, HLJ-5X (Option H3)	--
1 *		PISTON, Lube (HLJ-5)	1
2	521-000-190	PISTON, Hydraulic (HLJ-5)	1
3	411-101-630+	PIN, Groove, part of kit 560-001-051 (HLJ-5)	1
4	422-021-110+	O-RING, Part of kit 560-001-051 (HLJ-5)	1
5	422-011-160+	O-RING, Part of kit 560-001-051 (HLJ-5)	1
	422-021-160+	O-RING, Part of kit 560-001-940 (HLJ-5X)	1
6	521-000-180	CAP, Cylinder	1
7 *		BODY, Pump, HLJ-5	1
8	419-130-070	SCREW, Socket-head, 1/4-20 x 1-1/4 inch, part of repair kit 560-001-051	4
9	422-011-140+	O-RING, Part of kit 560-001-051 (HLJ-5)	1
	422-021-140+	O-RING, Part of kit 560-001-940 (HLJ-5X)	1
10	521-003-000	SCREW, Adjustment	1
11	521-008-460	SCREW, Enclosure	1
12	500-132-000+	GASKET, Part of kits 560-001-051 and 560-001-940	1
13	511-893-000+	SPRING, Check valve, part of kits 560-001-051 and 560-001-940	1
14	401-030-030+	BALL, Steel, 3/16 inch, part of kits 560-001-051 and 560-001-940	1
15	423-700-113+	O-RING, Part of kits 560-001-051 and 560-001-940	3
16	423-700-114+	O-RING, Part of kits 560-001-051 and 560-001-940	1
17	521-003-030	BODY, Adjustment screw (HLJ-5)	1
	521-005-710	BODY, Adjustment screw (HLJ-5X)	1
18	439-040-050+	GASKET, Stat-O-Seal, part of kit 560-001-051 (HLJ-5)	2
	439-050-050+	GASKET, Stat-O-Seal, part of kit 560-001-940 (HLJ-5X)	2
19	410-702-028	NUT, Jam, Part of Kit 560-001-051	1
20	521-002-970	CAP, Adjustment screw (HLJ-5)	1
	521-010-360	CAP, Adjustment screw (HLJ-5X)	1
21	527-000-790+	O-RING, Part of kit 560-001-051 (HLJ-5)	1
22	521-008-450+	SEAT, Check valve, part of kits 560-001-051 and 560-001-940	1
23	422-010-080+	O-RING, Part of kits 560-001-051 and 560-001-940	1
25	423-700-057+	RING, Backup, part of kit 560-001-940 (HLJ-5X)	2
26	423-700-060+	O-RING, Part of kit 560-001-940 (HLJ-5X)	1
27*		PISTON (HLJ-5X)	1
28	423-700-058+	RING, Backup, part of kit 560-001-940 (HLJ-5X)	2
29	423-700-059+	O-RING, Part of kit 560-001-940 (HLJ-5X)	1
30	521-000-050	SCREW, Enclosure	1
31	401-010-010	BALL, Steel 1/8" Dia., Part of Kit 560-001-051	1
32	417-450-020	SCREW, Set 10-32"x1/4"	1
--	560-001-051	REPAIR KIT (consists of Items 3, 4, 5, 8, 9, 12 thru 16, 18, and 21 thru 23)	1
--	560-001-940	REPAIR KIT (consists of Items 5, 9, 12 thru 16, 18, 22 thru 26, 28 and 29)	1
--	521-001-391	PUMP ADJ. ASSEMBLY (consists of Items 10 & 17 thru 20) (HLJ-5)	1

* Not Available as Replacement Parts.

+ Included in Repair Kit.

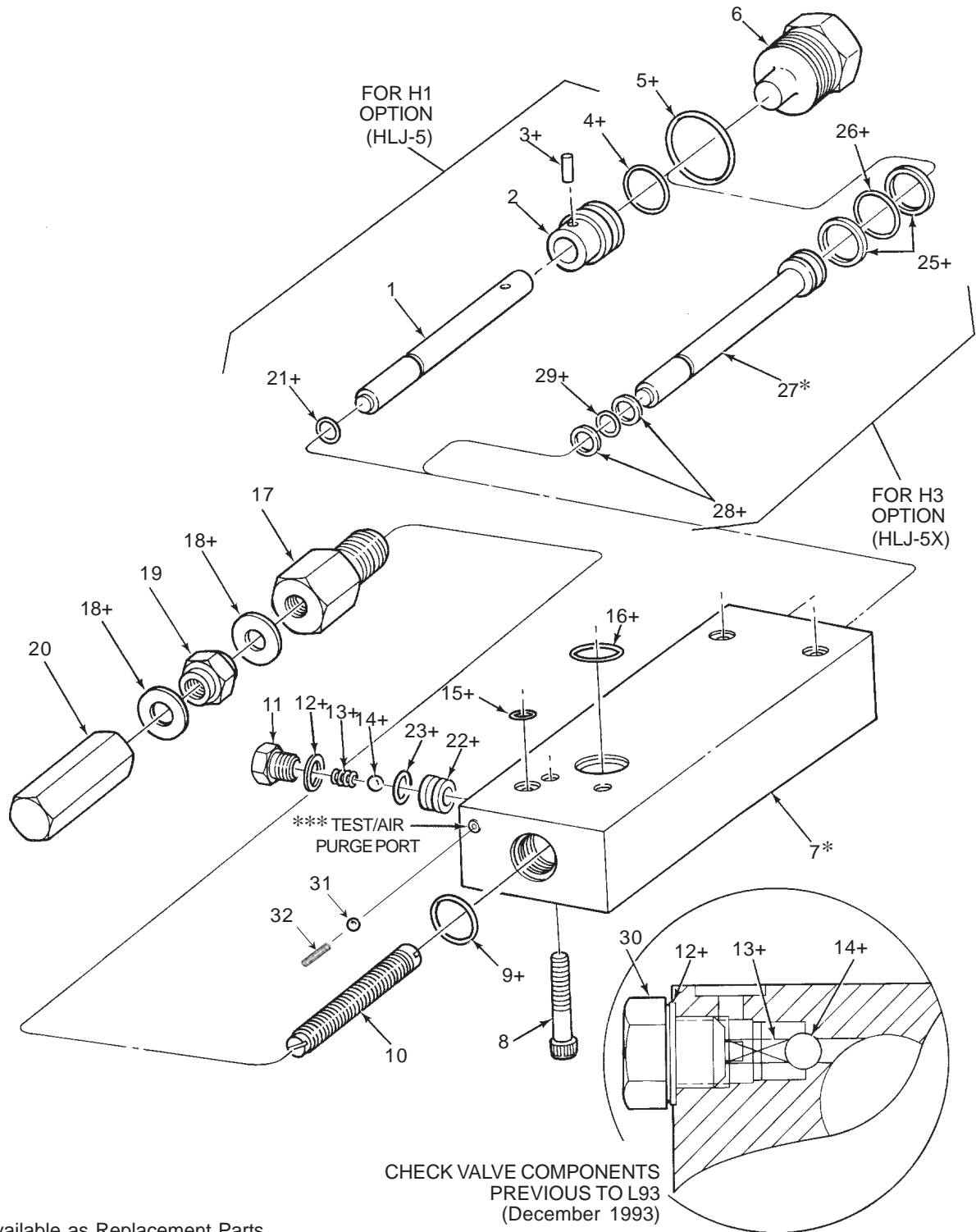

* Not Available as Replacement Parts.
 + Included in Repair Kit. Refer to Page 3-10 for Repair Kits

*** SEE NOTE ON PAGE 4.2

Figure 3-3. Hydraulic Pump Options H1 and H3 - Exploded View

3.5 HYDRAULIC PUMP MAINTENANCE (OPTION H2)

3.5.1 General. Maintenance tips, disassembly and assembly procedures for hydraulic pump Option H2 are discussed in Paragraphs 3.5.2 through 3.5.4. An exploded view of the pump is shown Figure 3-4 and should be referred to during the discussion.

3.5.2 Hydraulic Pump Option H2 Maintenance Tips.

3.5.2.1 The only maintenance required on the hydraulic pump Option H2 is to check for the following:

- a. Check four socket-head screws (11, Figure 3-4) to make sure they are tight. Loose screws could allow air and/or lubricant to leak between the pump and the manifold. This condition could result in erratic pump output.
- b. Check for leakage past gasket (15). Replace gasket if required.
- c. Check jam nut (21) to make sure it is tight against adjustment screw body (19). If the jam nut is loose, the adjustment screw (13) could rotate and cause the pump output to change. This condition could also result in lubricant leakage or in air being sucked into the lubricant.

3.5.2.2 If internal components of the pump are defective it will usually result in erratic pump operation or output. Section 9 of the manual lists causes and solutions for problems which could occur in the Modu-Flo system. Before disassembling any pump, refer to Section 9. The problem may be caused by other conditions which can be checked first before breaking down the pump.

3.5.3 Disassembly of Hydraulic Pump Option H2. The procedure below describes complete disassembly of a pump. However, you only need to disassemble to your specific area of concern.

3.5.3.1 The disassembly procedure for the hydraulic pump Option H2 is as follows:

NOTE

Figure 3-4 shows hydraulic cylinder (7) separated from body (10). To achieve disassembly to this level requires special tools to remove hydraulic cylinder retainer (23). Normally, this level of disassembly is only performed at the factory. If scoring or wear marks are evident on the inner diameter of hydraulic cylinder (7) or body (10), the pump cannot be serviced and should be replaced.

- a. Separate pump from manifold by removing four socket-head screws (11). Remove and discard three o-rings (9) and one o-ring (18).
- b. Remove enclosure screw (14). Remove and discard gasket (15), check valve spring (16), steel ball (29), check seat (25), and o-ring (26).
- c. Remove adjustment screw body (19) and o-ring (12) from body (10). Discard o-ring (12). Removal of adjustment screw (13) from adjustment screw body (19) will change output setting when pump is reas-

sembled. If adjustment screw (13) requires removal, perform the following:

- (1) Remove adjustment screw cap (22) from adjustment screw (13). Butt the adjustment screw cap (21) against jam nut (22) and use the stamped numbers on the cap to measure how far the adjustment screw (13) extends from the jam nut. Record this dimension.
- (2) Remove jam nut (21) and two gaskets (20). Discard gaskets.
- (3) Remove adjustment screw (13) by screwing it towards the hex portion of the adjustment screw body (19) until it is free.
- d. Remove cylinder cap (6). Remove and discard o-ring (5).
- e. Use wooden dowel or soft rod to push hydraulic piston (2) and lube piston (1) from hydraulic cylinder (7). Remove and discard o-rings (4 and 9) and backup rings (24).
- f. Separate hydraulic piston (2) from lube piston (1) by removing groove pin (3).

3.5.4 Assembly of Hydraulic Pump Option H2.

NOTE

Use new o-rings and gaskets when assembling pump. Lubricate all o-rings and sliding parts with the lubricant which is used in the system.

3.5.4.1 Assemble the hydraulic pump Option H2 according to the following procedure:

- a. Insert lube piston (1) into hydraulic piston (2). Insert groove pin (3) to secure the assembly.
- b. Install new o-ring (4) and backup rings (24) on hydraulic piston (2). Install new o-ring (9) on lube piston (1). Push piston assembly through hydraulic cylinder (7) into body (10).
- c. Install new o-ring (5) on cylinder cap (6). Screw cylinder cap into hydraulic cylinder (7) and tighten securely.
- d. Insert smaller end of adjustment screw (13) into adjustment screw body (19). Rotate adjustment screw (13) until smaller end is protruding from hex portion of adjustment screw body (19).
- e. Install new o-ring (12) on adjustment screw body (19) and install adjustment screw body in body (10). Tighten securely.
- f. Install jam nut (21) and two new gaskets (20), one on each side of jam nut, on adjustment screw (13). Butt adjustment screw cap (22) against jam nut (21) and turn adjustment screw (13) until the length it extends beyond the jam nut is the same as the length recorded during disassembly.
- g. Install adjustment screw cap (22) on adjustment screw (13).
- h. Install new o-ring (26) on check seat (25) and install check seat assembly into pump body. Install new ball (29) and new check valve spring (16) into body (10).

- Place new gasket (15) on enclosure screw (14). Screw enclosure screw (14) into body (10) and tighten securely.
- i. Install three new o-rings (9) and one new o-ring (18) into body (10). Securely attach pump to manifold using four socket-head screws (11).

3.5.4.2 When the assembly steps listed above have been completed, adjust the pump output as described in Paragraph 3.2.2.

3.5.5 Hydraulic Pump Option H2 Parts List. Table 3-4 identifies the parts indexed in Figure 3-4.

Table 3-4. Hydraulic Pump Option H2 Parts List

Item Number	Part Number	Description	Quantity
	521-000-031	PUMP ASSEMBLY, HL-25 (Option H2)	--
1 *		PISTON, Lube	1
2	521-000-310	PISTON, Hydraulic	1
3	411-101-660+	PIN, Groove, part of kit 521-001-061	1
4	422-021-160+	O-RING, Part of kit 521-001-061	1
5	422-011-220+	O-RING, Part of kit 521-001-061	1
6	521-000-300	CAP, Cylinder	1
7	521-000-290	CYLINDER, Hydraulic	1
8	422-010-200+	O-RING, Part of kit 521-001-061	1
9	423-700-111+	O-RING, Part of kit 521-001-061	1
10 *		BODY, Pump	1
11	419-130-070+	SCREW, Socket-head, 1/4-20 x 1-1/4 inch	4
12	422-011-140+	O-RING, Part of kit 521-001-061	1
13	521-003-010	SCREW, Adjustment	1
14	521-008-460	SCREW, Enclosure	1
15	500-132-000+	GASKET, Part of kit 521-001-061	1
16	511-893-000+	SPRING, Check valve, part of kit 521-001-061	1
17	401-030-030+	BALL, Steel, 3/16 inch, part of kit 521-001-061	1
18	423-700-114+	O-RING, Part of kit 560-001-061	1
19	521-003-040	BODY, Adjustment screw	1
20	439-040-070+	GASKET, Stat-O-Seal, part of kit 521-001-061	2
21	410-702-033+	NUT, Jam, 7/16-20	1
22	521-002-980	CAP, Adjustment screw	1
23	521-000-330	RETAINER	1
24	423-700-063+	RING, Backup, part of kit 560-001-061	1
25	521-008-450+	SEAT, Check valve, part of kit 560-001-061	1
26	422-010-080+	O-RING, Part of kit 560-001-061	1
27	423-700-113+	O-RING, Part of kit 560-001-061	5
30	521-000-050	SCREW, Enclosure	1
31	401-010-010+	BALL, Steel 1/8" Dia.	1
32	417-450-020+	SCREW, Set 10-32"x1/4"	1
33	411-700-763+	ROLL PIN	1
--	560-001-061	REPAIR KIT (consists of Items 3, 4, 5, 8, 9, 11,12, 15 thru 18, 20, 21, 24 thru 27 and 31 thru 33)	1
--	521-001-401	PUMP ADJUSTMENT ASSEMBLY (consists of Items 13 and 19 thru 22)	1

* Not Available as Replacement Parts

+ Included in Repair Kit.

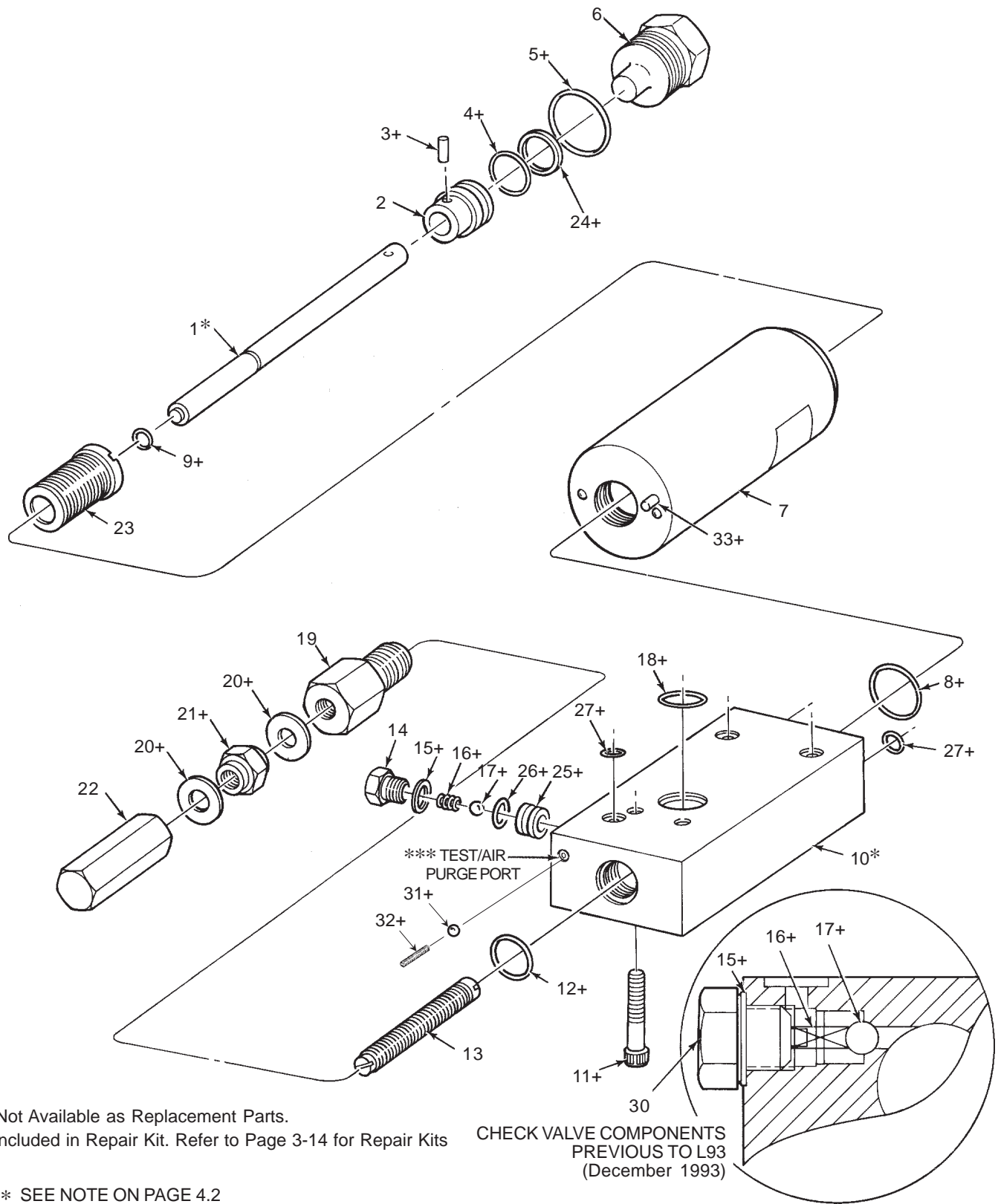

Figure 3-4. Hydraulic Pump Option H2 - Exploded View

OPERATION AND SERVICE INSTRUCTIONS

Modu-Flo® System

SECTION 4

MANIFOLDS

4.1 DESCRIPTION 4-1
 4.1.1 General 4-1
 4.2 PREPARATION FOR USE 4-1
 4.2.1 Mounting 4-1
 4.2.2 Connection to Other Components 4-1
 4.3 MAINTENANCE 4-1

4.1 DESCRIPTION

4.1.1 General. Two modular-design manifolds are available. Either manifold is designed to have any of the pneumatic or hydraulic pumps mount directly to it. The pump-to-reservoir manifold attaches directly to the base of the lubricant reservoir or tank. The pump-to-wall manifold is used to mount the lubricant pump in a remote location, separate from the lubricant reservoir or tank.

4.1.1.1 The manifolds contain the pneumatic (or hydraulic) porting and lubricant lines necessary to operate the pump and to direct the lubricant flow. A shutoff is built into the manifold to prevent lubricant from leaking from the reservoir or tank when the pump is removed.

4.1.1.2 Table 4-1 lists the operating ports used on the manifolds. Each port is identified by stamped lettering. Table 4-2 lists the part numbers of the manifolds accessories. Manifolds and accessories can be ordered separately or as a combination package. Figure 4-1 shows a typical manifold with various accessories connected to the lube ports.

4.2 PREPARATION FOR USE

4.2.1 Mounting. Pump-to-reservoir manifolds mount directly to the base of the reservoir or tank with two 3/8-16

socket-head screws. Pump-to-wall manifolds require that the surface that the manifold will be attached to has two 3/8-16 tapped holes 2-1/4 inches apart. The manifold must be mounted so that when the pump is mounted the enclosure screw on the pump will be on top. This will ensure proper bleeding and priming of the system.

4.2.2 Connection to Other Components. Four 1/4-20 tapped holes are provided on the manifold for pump attachment. The holes are laid out in a way that prevents the pump from being mounted incorrectly. The operating ports, listed in Table 4-1, must be connected by hose or tubing to their appropriate locations.

4.3 MAINTENANCE

4.3.1 There is little maintenance required on the manifold assemblies. All fittings and accessories used on the unit should be tightened to avoid leakage. If any accessory shows evidence of failure it may be removed by simply unscrewing it from the manifold. Refer to disassembly procedures in Section 2 for draining techniques. The pump does not need to be removed from the manifold but it may be desired if space is limited.

NOTE

Ensure all lubricant is drained from reservoir before removing manifold.

Table 4-1. Operating Ports on Modu-Flo Manifolds

Port Name	Function
DA (Double Acting)	Single-acting model pumps: Port is fitted with a plastic vent orifice plug so that air can be exhausted on piston return stroke. Double acting model pumps: Port has air or hydraulic supply connected to it. Fluid directed to this port causes the pump to retract to the loading position.
GAUGE	Port for attaching a pressure gauge to indicate pump output pressure. This port is common to the LUBE OUT port.
IND	Port for attaching a blowout or pressure indicating assembly. This port is common to the LUBE OUT port.
SYS FILL	Port for attaching an inlet check valve. This allows the lubrication lines to be filled by an outside source of lubricant so that the pump does not cycle excessively when filling the system.
LUBE OUT	Port that the system being lubricated is connected to. An outlet check valve is installed here.
SA (Single Acting)	Port has a pneumatic or hydraulic supply source connected to it. Fluid directed to this port causes the pump to dispense.
TEST **	Port is used for bleeding air out of pump. Back out setscrew one or two turns while pump is in the dispense stroke. Close setscrew when pump is on return stroke to prevent air from being sucked in. Repeat process until air-free lubricant comes from vent hole.
LUBE IN Pump-to-Wall (Remote) Manifold Only	Port that the lubricant reservoir or tank outlet is connected to.
** On newer units, the test port has been relocated to the adjustment end of the pump body. The use and function of this port is the same in either location.	

Table 4-2. Manifolds and Manifold Accessories

Item	Part Number
Pump-to-Reservoir Manifold Only	521-001-540
Pump-to-Reservoir Manifold Assembly: Includes outlet check valve, System fill check valve,blowout assembly, and pressure gauge	521-001-180
Pump-to-Wall (Remote) Manifold Assembly: Includes outlet check valve, system fill check valve, and blowout assembly	521-001-170
Pump-to-Reservoir Manifold Combination: Includes outlet check valve, system fill check valve, tubed blowout assembly, and pressure gauge	521-001-790
Pump-to-Wall (Remote) Manifold Combination: Includes outlet check valve, system fill check valve, and blowout assembly for high pressure alarm.	521-001-780
Outlet Check Valve	509-360-030
System Fill Check Valve	509-365-030
Elbow, 1/4 inch pipe	509-113-000
Pipe Plug, 1/4 inch	508-975-000
Plastic Vent Plug, 1/4 inch (Located in D.A. Port) (Yellow)	521-001-160
Standard Blowout Assembly (1450 psi)	509-206-100
Tubed Blowout Assembly (1450 psi)	509-220-101
*Bag of 6 Discs (1450 psi)	560-900-270
Standard Pressure Gauge (0-3,000 psi)	543-362-000
Liquid-filled Pressure Gauge (0-3,000 psi)	543-711-380
Manifold to Reservoir O-Ring (Buna-N) (Included with pump to reservoir manifold assemblies)	422-010-210

* Refer to Section 6 for kits in other pressure ranges.

Above items are for manifolds with 1/4" NPSF ports. Consult factory for manifolds and accessories with SAE, BSPP, and metric threads.

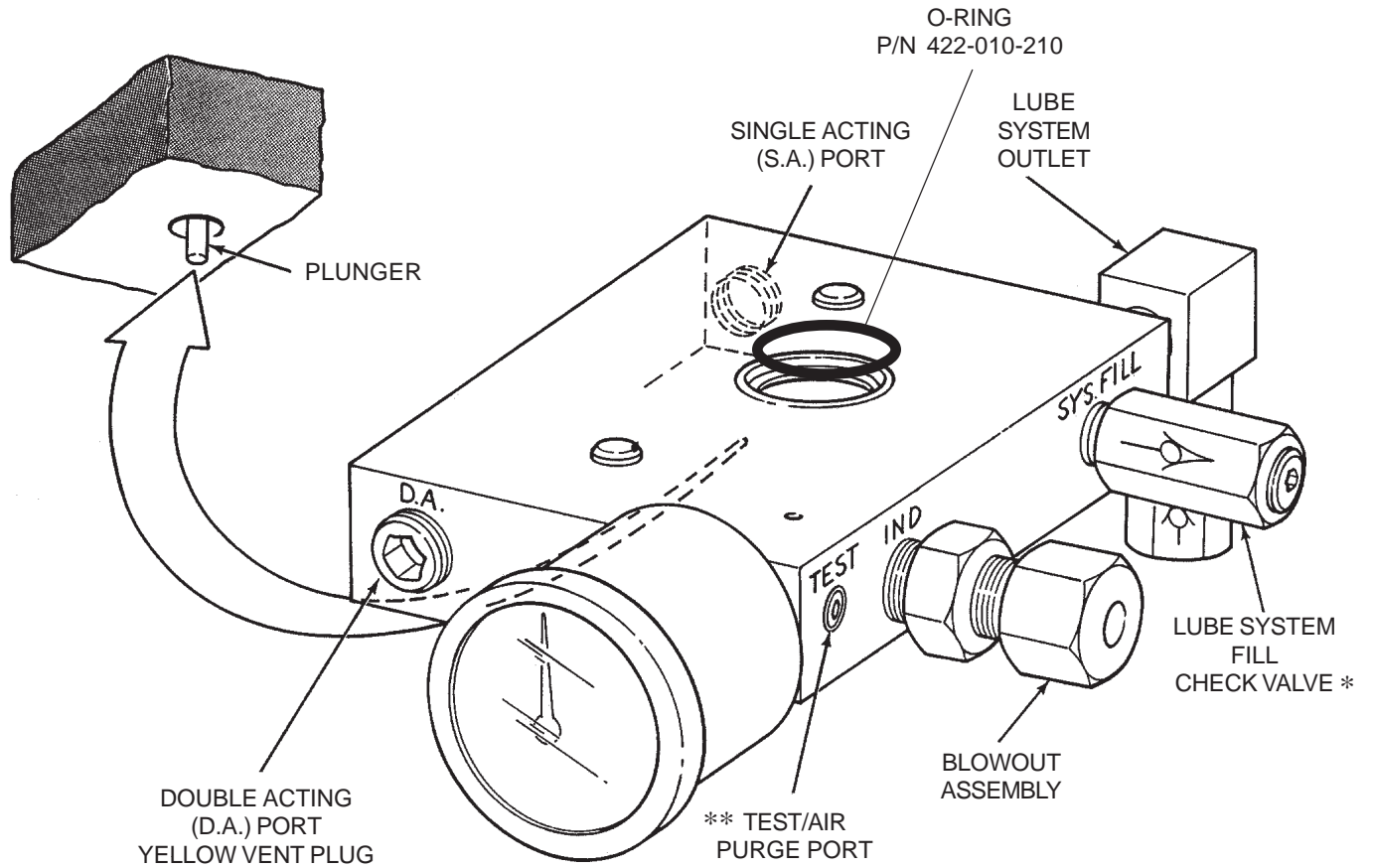

* This port is used to manually fill system lube lines. This is not the reservoir fill port. See figure 2-1 on page 2-5, item 15 for location of grease reservoir fill.

** On newer units, the test port has been relocated to the adjustment end of the pump body. The use and function of this port is the same in either location.

Figure 4-1. Typical Manifold Assembly

OPERATION AND SERVICE INSTRUCTIONS

Modu-Flo® System

SECTION 5

LOW-LEVEL SWITCHES

5.1 DESCRIPTION	5-1	5.4.1 General	5-4
5.1.1 General	5-1	5.4.2 Oil Tank and Reservoir 10-Watt Low-Level Assembly Maintenance Tips	5-4
5.2 MOUNTING INSTRUCTIONS	5-1	5.4.3 Disassembly of Oil Tank and Reservoir 10-Watt Low-Level Assemblies	5-4
5.2.1 Oil Reservoirs and Tanks	5-1	5.4.4 Assembly of Oil Tank and Reservoir 10-Watt Low-Level Assemblies	5-4
5.2.2 Grease Cylinders	5-1	5.4.5 Oil Tank and Reservoir 10-Watt Low-Level Assemblies Parts List	5-4
5.3 OIL TANK AND RESERVOIR 15 AMP LOW-LEVEL ASSEMBLY MAINTENANCE (OPTIONS L1, L2 and L3)	5-2	5.5 GREASE RESERVOIR LOW-LEVEL ASSEMBLY MAINTENANCE (OPTION L4)	5-5
5.3.1 General	5-2	5.5.1 General	5-5
5.3.2 Oil Tanks and Reservoir 15 Amp Low-Level Assembly Maintenance Tips	5-2	5.5.2 Grease Reservoir Low-Level Assembly Maintenance Tips	5-5
5.3.3 Disassembly of Oil Tank and Reservoir 15 Amp Low-Level Assemblies	5-2	5.5.3 Disassembly of Grease Reservoir Low-Level Assembly	5-5
5.3.4 Assembly of Oil Tank and Reservoir 15 Amp Low-Level Assemblies	5-2	5.5.4 Assembly of Grease Reservoir Low-Level Assembly	5-6
5.3.5 Oil Tank and Reservoir 15 amp Low-Level Assemblies Parts List	5-3	5.5.5 Grease Reservoir Low-Level Assembly Parts List	5-6
5.4 OIL TANK RESERVOIR 10-WATT LOW-LEVEL ASSEMBLY MAINTENANCE (OPTIONS L5, L6 AND L7)	5-4		

5.1 DESCRIPTION

5.1.1 General. Several varieties of assemblies are available to provide a signal when the lubricant level is low. Low-level switch assemblies used on oil tanks or reservoirs depend on floats that fall with the depletion of lubricant and actuate contacts on the switch. Switch assemblies used on grease reservoirs are actuated when a cable attached to the grease follower is pulled away from the switch as the follower reaches the low position. Switch assemblies used in oil reservoirs and grease reservoirs are rated 15 amps. Optional 10-watt assemblies are available for oil tanks and reservoirs.

5.1.1.1 The low-level assemblies with a 15 amp rating are often used to activate a warning device such as a light or alarm. The optional 10-watt assemblies are used to provide input to controllers which may be programmed to use the input signal as desired.

5.1.1.2 Table 5-1 lists the low-level assemblies available for use. Listings in the option column are used to identify the assembly selected when a Modu-Flo system is ordered.

The option used is designated by the entry in the ordering code as shown below.

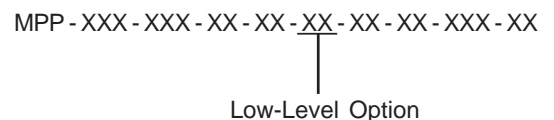

5.2 MOUNTING INSTRUCTIONS

5.2.1 Oil Reservoirs and Tanks. To install any low-level switch in a reservoir or tank requires the removal of the tank cover or reservoir cap. All covers or caps are equipped with a 1/4 inch NPT tapped hole. The low-level switch has an adapter which threads into the hole. For complete instructions on mounting these units, refer to Paragraphs 5.3.4 and 5.4.4.

5.2.2 Grease Cylinders. The low-level switch for grease cylinders consists of the switch itself mounted to a bracket which is, in turn, attached to the top of the grease cylinder. For complete instructions on mounting these units refer to Paragraph 5.5.4.

Table 5-1. Low-Level Switch Assemblies

Part Number	Switch Type	Switch Rating AC	Used On	Option
521-001-030	Single-pole, double-throw	15 amps at 115, 230 or 480 VAC	5- and 12-pint oil cylindrical reservoirs	L1
521-001-040	Single-pole, double-throw	15 amps at 115, 230 or 480 VAC	20-pint oil cylindrical reservoir	L2
521-001-050	Single-pole, double-throw	15 amps at 115, 230 or 480 VAC	6-pint oil cylindrical reservoir and all tanks	L3
456-010-171	Single-pole, single-throw	10 watts at 115 VAC	6-pint oil cylindrical reservoir and oil tanks	L7
456-010-172	Single-pole, single-throw	10 watts at 115 VAC	5- and 12-pint oil cylindrical reservoir	L5
456-010-173	Single-pole, single-throw	10 watts at 115 VAC	20 pint oil cylindrical reservoir	L6
521-001-110	Single-pole, double-throw	15 amps at 115, 230 or 480 VAC, 0.5 amp at 115 VDC, 0.25 amp at 230 VDC	All grease cylindrical reservoirs	L4

5.3 OIL TANK AND RESERVOIR 15 AMP LOW-LEVEL ASSEMBLY MAINTENANCE (OPTIONS L1, L2 and L3)

5.3.1 General. Maintenance tips, disassembly and assembly procedures for low-level options L1, L2 and L3 are discussed in Paragraphs 5.3.2, 5.3.3 and 5.3.4. A typical low-level assembly is shown in Figure 5-1 and should be referred to during this discussion.

5.3.2 Oil Tanks and Reservoir 15 Amp Low-Level Assembly Maintenance Tips. No maintenance is required on the low-level assemblies used on oil tanks and reservoirs. If the oil level runs down and the assembly fails to perform as required, the unit may have to be disassembled to replace a defective switch. Before attempting disassembly, check all electrical connections to make sure they are secure and check for any physical obstruction which might be preventing the float from operating.

5.3.3 Disassembly of Oil Tank and Reservoir 15 Amp Low-Level Assemblies.

5.3.3.1 The disassembly procedure is as follows:

WARNING

Disconnect and lock out all power from the assembly before attempting disassembly. Serious injury may result from electrical shock.

- a. Turn off all electrical power and all air supplies to the lube system.
- b. Remove cover from reservoir (Refer to Section 2.).
- c. Unscrew union nut (5, Figure 5-1) from switch adapter (2).
- d. Unscrew switch adapter (2) from switch (1).
- e. Remove actuating rod, part of low-level lower assembly (4), from remaining assembly.
- f. Unscrew low-level lower assembly (4) from low-level adapter (3).
- g. Unscrew low-level adapter (3) from the reservoir cover. Remove low-level adapter (3) from union nut (5).

5.3.4 Assembly of Oil Tank and Reservoir 15 Amp Low-Level Assemblies.

5.3.4.1 The assembly procedure is as follows:

NOTE

The procedure listed below is based on installing a new assembly in a tank or reservoir. If your assembly was removed for repairs, steps a and b do not apply.

- a. Remove cover from reservoir (Refer to Section 2.).
- b. Remove 1/4 inch pipe plug from reservoir cover. Insert low-level adapter (3, Figure 5-1) into union nut (5). Screw low-level adapter (3) into the reservoir cover and tighten securely.

c. Screw low-level lower assembly (4) into low-level adapter (3) and tighten securely.

e. Screw switch adapter (2) into switch (1) and tighten securely.

NOTE

If float portion of low-level lower assembly was removed during disassembly, apply Locktite to the attaching bolt and securely attach the float to the arm.

f. Screw union nut (5) onto switch adapter (2) and tighten securely.

g. Install cover on reservoir (Refer to Section 2.).

h. Wire switch in accordance with local electrical codes.

d. Insert the actuating rod, part of low-level lower assembly (4), into this assembly.

5.3.5 Oil Tank and Reservoir 15 Amp Low-Level Assemblies Parts List. Table 5-2 identifies the parts indexed in Figure 5-1.

Table 5-2. Oil Tank and Reservoir 15 Amp Low-Level Assemblies Parts List

Item Number	Part Number	Description	Quantity
	521-001-030	LOW-LEVEL ASSEMBLY (5 pint, 12 pint)	--
	521-001-040	LOW-LEVEL ASSEMBLY (20 pint)	--
	521-001-050	LOW-LEVEL ASSEMBLY (6 pint)	--
1	514-116-001+	SWITCH	1
2 *		ADAPTER, Switch	1
3 *		ADAPTER, Low-level	1
4 *		LOW-LEVEL LOWER ASSEMBLY	1
5 *		NUT, Union	1

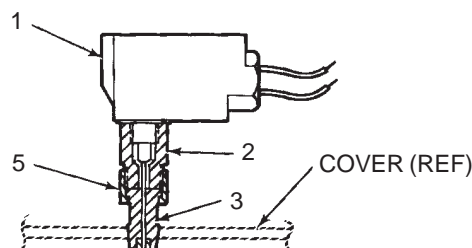

+ When replacing item (1) switch only, remove lock nut from new switch plunger housing before assembling switch to item (2) adapter.

* Not available as replacement parts.

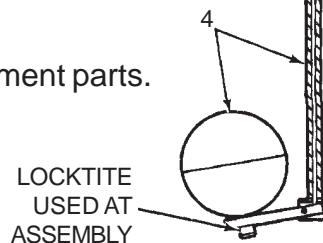

Figure 5-1. Oil Tank and Reservoir 15 Amp Low-Level Assembly

5.4 OIL TANK RESERVOIR 10-WATT LOW-LEVEL ASSEMBLY MAINTENANCE (OPTIONS L5, L6 AND L7)

5.4.1 General. Maintenance tips, disassembly and assembly procedures for low-level options L5, L6 and L7 are discussed in Paragraphs 5.4.2, 5.4.3 and 5.4.4. A sectional view of a low-level assembly is shown in Figure 5-2 and should be referred to during the discussion.

5.4.2 Oil Tank and Reservoir 10-Watt Low-Level Assembly Maintenance Tips. No maintenance is required on the 10-watt low-level assemblies used on oil tanks and reservoirs. If the oil level runs down and the assembly fails to perform as required the unit may have to be disassembled to replace a defective switch. Before attempting disassembly, check all electrical connections to make sure they are secure and check for any physical obstructions which might be preventing the float from operating.

5.4.3 Disassembly of Oil Tank and Reservoir 10-Watt Low-Level Assemblies.

5.4.3.1 The disassembly procedure for oil tank and reservoir 10-watt low-level assemblies is as follows:

WARNING

Disconnect and lock out all power from the assembly before attempting disassembly. Serious injury may result from electrical shock.

- a. Turn off all electrical power and air supplies to the lube system.
- b. Disconnect the two 22 AWG wires from the terminal box. Disconnect adapter (1, Figure 5-2) from the conduit.
- c. Remove the cover from the tank or reservoir (Refer to Section 2.).

- d. Unscrew nipple (2) from adapter (1). Be careful not to twist the wires too much.
- e. Unscrew nipple (2) from coupling (3).
- f. Unscrew coupling (3) from switch (4).
- g. Unscrew adapter (1) from the reservoir cover.

5.4.4 Assembly of Oil Tank and Reservoir 10-Watt Low-Level Assemblies.

5.4.4.1 The assembly procedure is as follows:

NOTE

The procedure listed below is based on installing a new assembly in a tank or reservoir. If your assembly was removed for repairs, steps a and b do not apply.

- a. Remove the cover from the reservoir (Refer to Section 2.).
- b. Remove the 1/4 inch pipe plug from the cover. Screw adapter (1, Figure 5-2) in and tighten it securely.
- c. Guide the two 22 AWG wires from switch (4) through coupling (3). Screw coupling (3) onto switch (4) and tighten securely.
- d. Guide two 22 AWG wires through nipple (2). Screw nipple into coupling (3).
- e. Guide the two 22 AWG wires through adapter (1). Screw nipple into adapter (1). Be careful not to twist the wires too much. Tighten the connection.
- f. Connect switch (4) in accordance with local electrical codes.

5.4.5 Oil Tank and Reservoir 10-Watt Low-Level Assemblies Parts List. Table 5-3 identifies the parts indexed in Figure 5-2.

Table 5-3. Oil Tank and Reservoir 10-Watt Low-Level Assemblies Parts List

Item Number	Part Number	Description	Quantity
	456-010-172	LOW-LEVEL ASSEMBLY (5 pint, 12 pint)	--
	456-010-173	LOW-LEVEL ASSEMBLY (20 pint)	--
	456-010-171	LOW-LEVEL ASSEMBLY (6 pint)	--
1	541-603-001	SWITCH, 10 watts, 115 VAC, NC SPST	1
	541-603-002	OPTIONAL SWITCH, 10 watts, 115 VAC, NO, SPST	
2 *		COUPLING	1
3 *		NIPPLE	1
4 *		ADAPTER	1

Figure 5-2. Oil Tank and Reservoir 10-Watt Low-Level Assembly

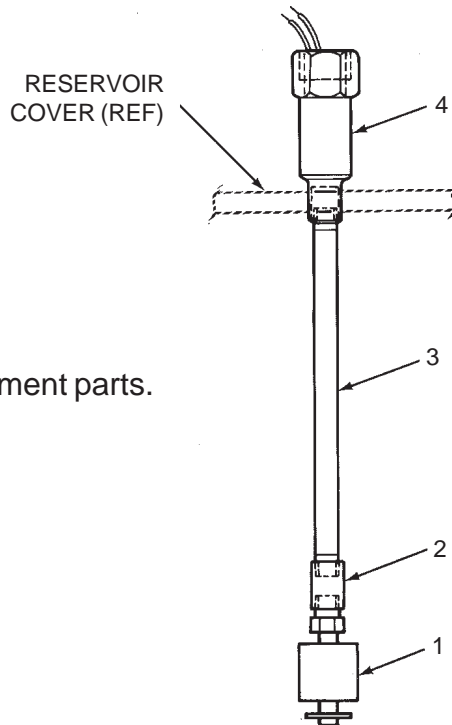

* Not available as replacement parts.

5.5 GREASE RESERVOIR LOW-LEVEL ASSEMBLY MAINTENANCE

(OPTION L4)

5.5.1 General. Maintenance tips, disassembly and assembly procedures for low-level assembly option L4 are discussed in Paragraphs 5.5.2, 5.5.3 and 5.5.4. A sectional view of a typical assembly is shown in Figure 5-3 and should be referred to during the discussion.

5.5.2 Grease Reservoir Low-Level Assembly Maintenance Tips. No maintenance is required on the low-level assemblies used on grease reservoirs. If the grease level runs down and the assembly fails to perform as required, the low level assembly may have to be disassembled to

replace a defective switch. Before attempting disassembly, check all electrical connections to make sure they are secure and check for any physical obstruction which might be preventing the switch from operating.

5.5.3 Disassembly of Grease Reservoir Low-Level Assembly.

5.5.3.1 The disassembly procedure for the grease reservoir low-level assembly is as follows:

WARNING

Disconnect and lock out all power from the assembly before attempting disassembly. Serious injury may result from electrical shock.

- a. Disconnect and lock out all electrical power and air supplies to the lube system.
- b. Disconnect switch (1, Figure 5-3) from terminal box. Remove switch (1) from bracket (2).
- c. Remove retainer ring (3) and spring (5).
- d. Remove three self-tapping screws (4) and bracket (2).

5.5.4 Assembly of Grease Reservoir Low-Level Assembly.

5.5.4.1 The procedure for assembly of the grease reservoir low-level assembly is as follows:

- a. Attach bracket (2) to grease reservoir cover using three self-tapping screws (4).
- b. Place spring (5) over tip of level indicator.
- c. Compress spring (5) and place retainer ring (3) between spring and tip of level indicator.
- d. Attach switch (1) to bracket (2).
- e. Wire switch (1) in accordance with local electrical codes.

5.5.5 Grease Reservoir Low-Level Assembly Parts List. Table 5-4 identifies the parts indexed in Figure 5-3.

Table 5-4. Grease Reservoir 15 Amp Low-Level Assembly Parts List

Item Number	Part Number	Description	Quantity
1	521-001-110	LOW-LEVEL SWITCH ASSEMBLY (Option L4)	--
	529-726-001	SWITCH	1
2	514-191-001	BRACKET	1
3	060251	RING, Retainer	1
4	415-210-010	SCREW, Self-tapping	3
5	542-939-000	SPRING	1

Figure 5-3. Grease Reservoir Low-Level Assembly

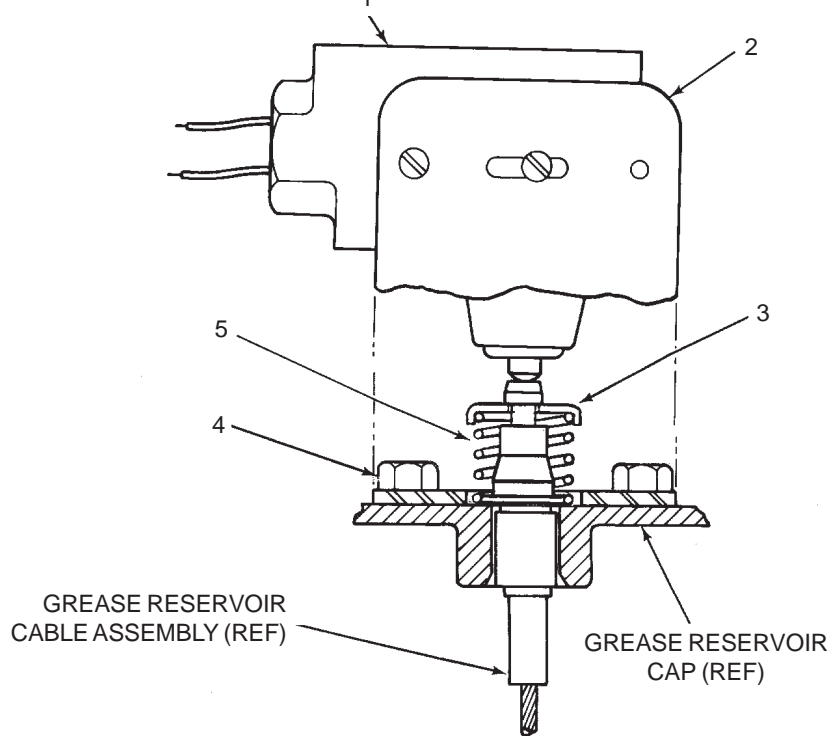

**OPERATION AND
SERVICE INSTRUCTIONS**

**Modu-Flo®
System**

SECTION 6

HIGH-PRESSURE AND BLOWOUT SWITCHES

<p>6.1 DESCRIPTION 6-1</p> <p>6.1.1 High-Pressure Switches 6-1</p> <p>6.1.2 Blowout Switches 6-1</p> <p>6.1.3 Blowout Disc 6-1</p> <p>6.1.4 High-Pressure and Blowout Switch Options 6-2</p> <p>6.2 HIGH-PRESSURE SWITCH ADJUSTMENT 6-2</p> <p>6.2.1 General 6-2</p> <p>6.2.2 High-Pressure Switch Adjustment Procedures 6-2</p> <p>6.3 MOUNTING INSTRUCTIONS 6-3</p> <p>6.4 HIGH-PRESSURE SWITCH MAINTENANCE (OPTION P1) 6-3</p> <p>6.4.1 General 6-3</p> <p>6.4.2 High-Pressure Switch Maintenance Tips 6-3</p>	<p>6.4.3 Assembly/Disassembly of High-Pressure Switch 6-3</p> <p>6.4.4 High-Pressure Switch Parts Lists 6-3</p> <p>6.5 RESERVOIR BLOWOUT SWITCH MAINTENANCE (OPTIONS P2 and P3) 6-4</p> <p>6.5.1 General 6-4</p> <p>6.5.2 Reservoir Blowout Switch Maintenance Tips 6-4</p> <p>6.5.3 Assembly/Disassembly of Blowout Switch .. 6-4</p> <p>6.5.4 Reservoir Blowout Switch Parts Lists 6-4</p> <p>6.6 TANK BLOWOUT SWITCH MAINTENANCE (OPTION P4) 6-6</p> <p>6.6.1 General 6-6</p> <p>6.6.2 Tank Blowout Switch Maintenance Tips 6-6</p> <p>6.6.3 Assembly/Disassembly of Blowout Switch .. 6-6</p> <p>6.6.4 Tank Blowout Switch Parts List 6-6</p>
---	---

6.1 DESCRIPTION

6.1.1 High-Pressure Switches. High-pressure switches may be plumbed into the lubricant output circuit to provide an electrical signal when excessive pressure is being approached. The pressure switch is factory set at 1150 psig (79 bar) and is used with a standard blowout disc rated at 1450 psig (100 bar). When output pressure reaches 1150 psig (79 bar), contacts on the switch will actuate and provide a warning signal to an external device. If the problem causing the high pressure is not corrected, the pressure will continue to rise. When pressure reaches 1450 psig (100 bar) the blowout disc will rupture and relieve the pressure. The setting of the pressure switch is adjustable. Adjustment procedures are discussed in Paragraph 6.2.2.

6.1.2 Blowout Switches. High-pressure blowout switch assemblies may be plumbed into the lubricant circuit to provide an electrical signal when the blowout disc has ruptured. On these assemblies, a tubed blowout assembly is used. The tubed blowout allows lubricant to flow from the ruptured blowout disc, through tubing up to an indicator assembly. The indicator assembly has a built-in check valve which will allow the lubricant to reach a pressure sufficient enough to extend a plunger. The extended plunger actuates a switch which will allow a signal to be sent to an alarm or other device. Lubricant from the indicator is directed through tubing and is returned to the inlet port on the reservoir or

tank. The indicator will retain the plunger in the extended position even if lubricant pressure is reduced. The plunger must be manually depressed to release the switch and return the indicator to its normal position.

6.1.3 Blowout Disc. The standard blowout disc, rated at 1450 psig (100 bar), may be used on any unit. This assembly does not provide any electrical signal when the blowout pressure has been reached. The blowout disc will rupture at the high pressure and the lubricant escaping from the blown disc will provide a visual indication of failure. Discs rated at higher pressures than 1450 psig (100 bar) are available separately in kits of six. For identification purposes, discs are color coded. Table 6-1 lists the discs available and the kit number for each.

Table 6-1. Blowout Discs and Kits

Disc Part No.	Color	Rating psi (bar)	Kit No. (contains 6 discs)
509-292-000	Yellow	1450 (100)	560-900-270
509-293-000	Red	1750 (121)	560-900-280
509-294-000	Orange	2050 (141)	560-900-290
509-295-000	Aluminum	2350 (162)	560-900-300
509-297-000	Blue	2950 (203)	560-900-320
509-298-000	Purple	3250 (224)	560-900-330

6.1.3.1 When any pressure or blowout switch is actuated, personnel must determine the cause for the rise in pressure. After the cause has been corrected, any blowout discs which have been ruptured will need to be replaced with an approved disc.

6.1.4 **High-Pressure and Blowout Switch Options.** Table 6-2 lists the pressure and blowout switch options available for use. Listings in the option column are used to identify the assembly selected when a Modu-Flo system is ordered. The option used is designated by the entry in the ordering code as shown below:

MPP - XXX - XXX - XX - XX - XX - XX - XX - XXX - XX
 |
 Pressure Indicator Option

6.2 HIGH-PRESSURE SWITCH ADJUSTMENT

6.2.1 **General.** The high-pressure switch assembly has an adjustable range from 400 to 4700 psi (28 to 324 bar). If the pressure setting is to be changed from the standard factory setting of 1150 psi (79 bar) the blowout disc must also be changed. To prevent system damage, the pressure switch setting should not exceed 80 percent of the blowout disc rating. Table 6-3 lists the blowout discs available and the maximum pressure switch setting to be used.

Table 6-2. High-Pressure and Blowout Switch Assemblies

Part Number	Description	Electrical Ratings	Used On	Option
521-001-220	Pressure Switch Kit	5 amp at 115/230 VAC	Any reservoir	P1
521-001-190	Blowout Assembly	15 amp at 115,230 or 480 VAC 0.5 amp at 115 VDC 0.25 amp at 230 VDC	5-pint or 5-pound cylindrical reservoir	P2
521-001-200	Blowout Assembly	15 amp at 115, 230 or 480 VAC 0.5 amp at 115 VDC 0.25 amp at 230 VDC	6, 12 or 20-pint or pound cylindrical reservoir	P3
521-001-210	Blowout Assembly	15 amp at 115, 230 or 480 VAC 0.5 amp at 115 VDC 0.25 amp at 230 VDC	All tanks	P4
509-206-100	Blowout Disc 1450 psi	None	All units	P5

6.2.2 High-Pressure Switch Adjustment Procedures.

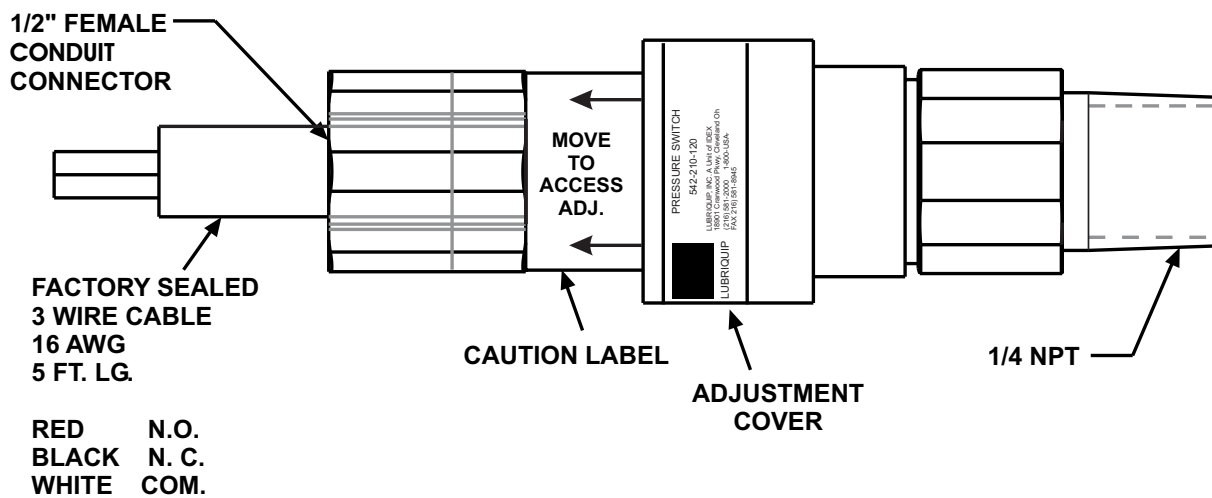

Figure 6-1. High-Pressure Switch

Table 6-3. Pressure Switch Settings

Disc Color	Disc Rating psi (bar)	Maximum Recommended Pressure Switch Setting psi (bar)
Yellow	1450 (100)	1160 (80)
Red	1750 (121)	1450 (100)
Orange	2050 (141)	1640 (113)
Aluminum	2350 (162)	1880 (130)
Blue	2950 (203)	2360 (163)
Purple	3250 (224)	2600 (179)

6.2.2.1 The adjustment procedure for the high-pressure switch is as follows:

WARNING

- Disconnect and lock out all power from the assembly before attempting disassembly. Serious injury may result from electrical shock.
 - To avoid possible system damage, change the blowout disc to match the new pressure switch setting. (Refer to Paragraph 6.2.1.)
- a. Turn off electrical power to the lube system.
 - b. Connect control to pressure source.
 - c. With power disconnected, slide cover toward electrical terminations while twisting it to overcome friction.
 - d. Connect power to terminals or leads.
 - e. Insert screwdriver into adjustment slot and turn clockwise to increase setting or counter-clockwise to decrease setting.

For setting on rise, apply desired pressure and turn adjustment (clockwise facing cable end of pressure switch) until switch clicks and/or tester confirms contact transfer (Circuit across N.O. and COM. terminals closes). For setting on fall, apply pressure equal to normal system operating pressure. Reduce source pressure to set point value. Turn adjustment counter-clockwise until switch clicks and/or tester confirms contact transfer (circuit across N.C. and COM. closes).
 - f. After completing adjustments, slide cover closed order adjustment compartment. Recheck set point.

6.3 MOUNTING INSTRUCTIONS

6.3.1 All high-pressure switches and blowout options are connected to the outlet of the manifold and mounted to various locations on the reservoir or tank. Refer to assembly Paragraphs 6.4.3, 6.5.3 and 6.6.3 for specific assembly instructions.

6.4 HIGH-PRESSURE SWITCH MAINTENANCE (OPTION P1)

6.4.1 General. Maintenance tips, disassembly and assembly procedures for the high-pressure switch are discussed in Paragraphs 6.4.2 and 6.4.3. A typical pressure switch is shown in Figure 6-2 and should be referred to during the discussion.

6.4.2 High-Pressure Switch Maintenance Tips. No maintenance is required on the high-pressure switch. If the switch is suspected to be defective, check all wiring to the switch before removing any components.

NOTE

Relieve system pressure before removing any components.

6.4.3 Assembly/Disassembly of High-Pressure Switch. Figure 6-2 shows a typical high-pressure switch mounted to a manifold. All components of the unit are connected by pipe threads and are easily assembled or disassembled. The blowout assembly (3) is connected to the IND port of the manifold and the pressure switch (1) is connected by fittings to the LUBE OUT port of the manifold. Normally, the only components which may require removal or replacement are the pressure switch (1) and the blowout disc (5). The pressure switch (1) is easily screwed out after all electrical connections are removed.

6.4.3.1 The blowout disc replacement procedure is as follows:

- a. Remove pressure relief nut (6) from adapter fitting (4).
- b. Remove blowout disc (5).
- c. Install new blowout disc (5) in pressure relief nut (6).
- d. Install pressure relief nut (6) on adapter fitting (4) and torque to 5 ft lbs.

6.4.4 Pressure Switch Parts Lists. Table 6-4 identifies the parts indexed in Figure 6-2.

Table 6-4. High-Pressure Switch Parts List

Index Number	Part Number	Description	Quantity
	521-001-220	HIGH-PRESSURE SWITCH ASSEMBLY (Option P1)	--
1	542-210-120	SWITCH, Pressure	1
2	412-380-020	TEE, Male, 1/4 inch pipe	1
3	509-206-100	BLOWOUT ASSEMBLY, 1450 psi	1
4	--	. FITTING, Adapter	1
5	--	. DISC, Blowout	1
6	--	. NUT, Pressure relief	1

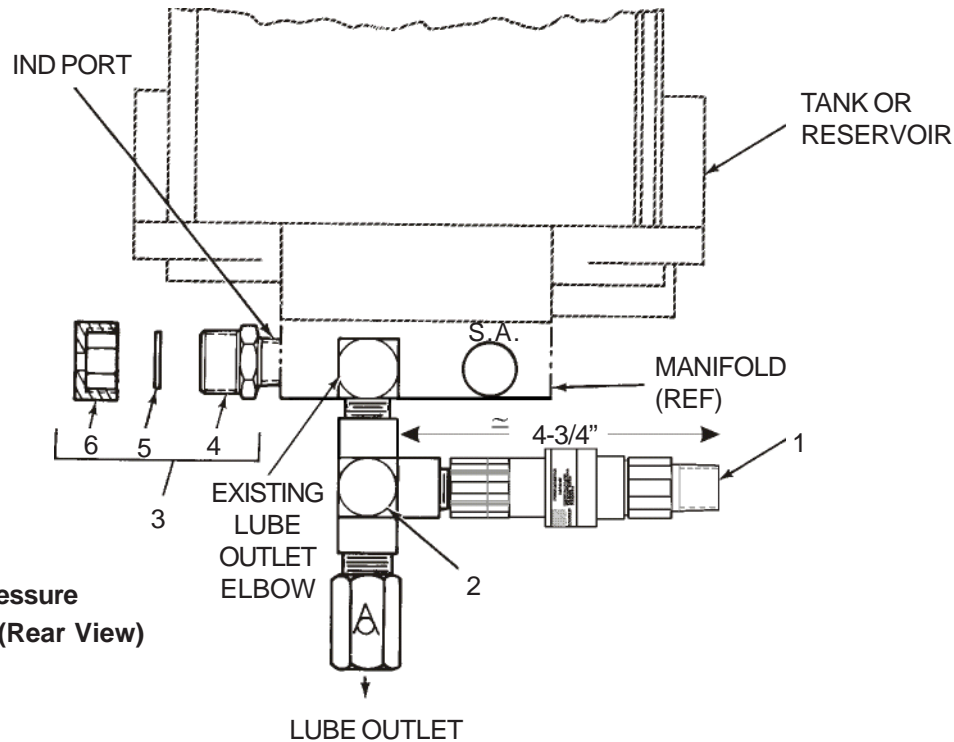

Figure 6-2. High-Pressure Switch (Rear View)

6.5 RESERVOIR BLOWOUT SWITCH MAINTENANCE (OPTIONS P2 and P3)

6.5.1 General. Maintenance tips, disassembly, and assembly instructions for reservoir blowout switches are discussed in Paragraphs 6.5.2, and 6.5.3. A typical reservoir with blowout switch is shown in Figure 6-3 and should be referred to during the discussion.

6.5.2 Reservoir Blowout Switch Maintenance Tips. No maintenance is required on the blowout switch. If the switch assembly is suspected to be defective, check all wiring to the switch before removing any components.

WARNING

Disconnect and lock out all power from the assembly before attempting disassembly. Serious injury may result from electrical shock.

NOTE

Relieve system pressure before removing any components.

6.5.3 Assembly/Disassembly of Blowout Switch. Figure 6-3 shows a typical blowout switch mounted on a reservoir. All components are connected by pipe threads and tubing and are easily assembled or disassembled. The blowout body (14) is connected to the IND port on the manifold. The return elbow (15) is piped into the fill port of the reservoir. Normally, the only components which may require removal are the switch (5), indicator assembly (10), and blowout disc. Access to these components is easily achieved after removal of any connective tubing.

6.5.4 Reservoir Blowout Switch Parts Lists. Table 6-5 identifies the parts indexed on Figure 6-3.

Table 6-5. Reservoir Blowout Switch Parts List

Item Number	Part Number	Description	Quantity
	521-001-190	HIGH-PRESSURE BLOWOUT SWITCH ASSEMBLY (5 pint/lb)	--
	521-001-200	HIGH-PRESSURE BLOWOUT SWITCH ASSEMBLY (6, 12 or 20 pint/lb)	--
1	521-000-760	BRACKET, Mounting, for 5 lb and 5 pt	1
	521-000-770	BRACKET, Mounting, for 6 lb, 12 lb, 20 lb, 6 pt, 12 pt, and 20 pt	1
2	416-701-992	SCREW, Round head, 6-32 x 1-3/8 inch, part of Part No. 511-573-030	2
3	421-070-050	LOCKWASHER, No. 6, part of part No. 511-573-030	4
4	410-030-050	NUT, Hex, 6-32, part of Part No. 511-573-030	2
5	529-726-001	SWITCH, Part of Part No. 511-573-030	1
6	501-967-001	BRACKET, Switch, part of Part No. 511-573-030	1
7	419-110-020	SCREW, Socket-head, 10-24 x 1/2 inch	2
8	417-060-060	SETSCREW, 1/4-20 x 1/2 inch	2
9	435-370-020	FITTING, Elbow, 1/8 NPT x 1/4 inch tube	2
10	511-160-001	INDICATOR ASSEMBLY, Part of Part No. 511-573-030	1
11+		TUBING, Copper, 1/4 inch outer diameter x 0.030 wall	3 ft
12	509-223-000	SPUD, Union	1
13	509-224-000	NUT, Union	1
14	509-208-000	BODY, Blowout	1
15	412-270-030	ELBOW, 1/4 inch NPT	1
16	412-380-020	TEE, 1/4 inch NPT	1
17	509-365-030	CHECK VALVE ASSEMBLY	1
18	435-360-030	FITTING, Straight, 1/4 tube x 1/4 inch NPT	1
--	511-573-030	BLOWOUT AND SWITCH ASSEMBLY	1
--	560-900-270*	BLOWOUT DISCS, Bag of 6, 1450 psi	1
19	435-360-020	FITTING, Straight, 1/4 inch tube x 1/8 inch NPT	1

* See Table 6-1 for other disc pressure ratings.

+ Tubing purchased separately

Figure 6-3. Reservoir Blowout Switch Assembly (Front View)

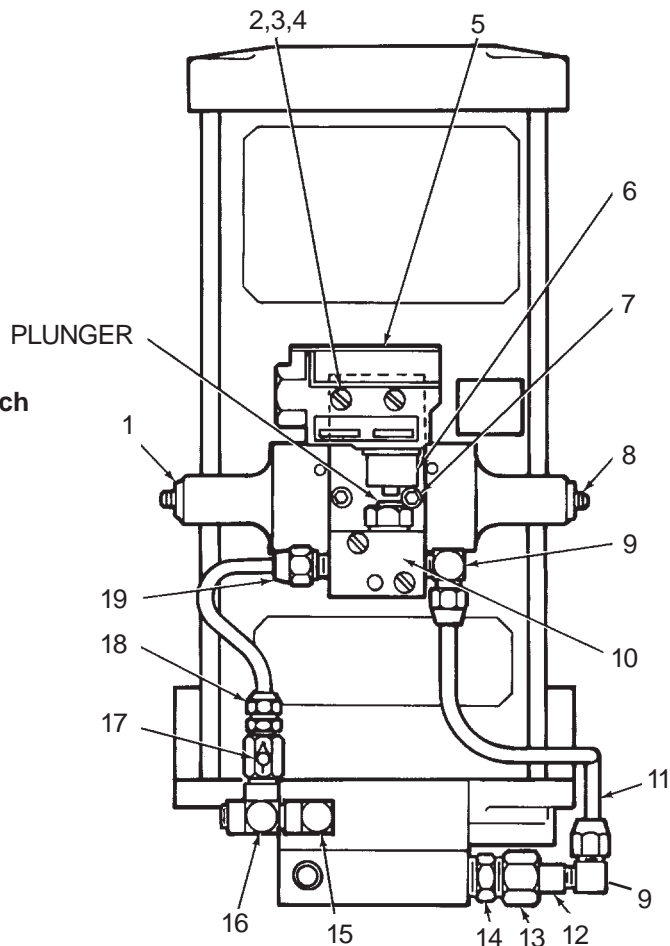

6.6 TANK BLOWOUT SWITCH MAINTENANCE (OPTION P4)

NOTE

Relieve system pressure before removing any components.

6.6.1 General. Maintenance tips, disassembly, and assembly instructions for tank blowout switches are discussed in Paragraphs 6.6.2 and 6.6.3. A typical tank with blowout switch is shown in Figure 6-4 and should be referred to during the discussion.

6.6.2 Tank Blowout Switch Maintenance Tips. No maintenance is required on the blowout switch. If this switch assembly is suspected to be defective, check all wiring to the switch before removing any components.

WARNING

Disconnect and lock out all power from the assembly before attempting disassembly. Serious injury may result from electrical shock.

6.6.3 Assembly/Disassembly of Blowout Switch. Figure 6-4 shows a typical blowout switch mounted on a tank. All components are connected by pipe threads and tubing and are easily assembled or disassembled. The blowout body (15) is connected to the IND port on the manifold. The return elbow (12) is piped into the fill port of the reservoir. Normally, the only components which may require removal are the switch (6), indicator assembly (8) and blowout disc. Access to these components is easily achieved after removal of any connective tubing.

6.6.4 Tank Blowout Switch Parts List. Table 6-6 identifies the parts indexed on Figure 6-4.

Table 6-6. Tank Blowout Switch Parts List

Item Number	Part Number	Description	Quantity
	521-001-210	BLOWOUT SWITCH ASSEMBLY (Option P4)	--
1	435-360-020	FITTING, Straight, 1/8 NPT x 1/4 inch tube	2
2	416-701-992	SCREW, Round head, 6-32 x 1-3/8 inch, included in Part No. 511-573-020	2
3	421-070-050	LOCKWASHER, No. 6, included in part Kit No. 511-573-020	4
4	410-030-050	NUT, Hex, No. 6-32, included in Part No. 511-573-020	2
5	419-110-020	SCREW, Socket-head, 10-24 x 1/2 inch	2
6	529-726-001	SWITCH, Included in part No. 511-573-020	1
7	501-967-001	BRACKET, Switch, included in part No. 511-573-020	1
8	511-160-001	INDICATOR ASSEMBLY, Included in part No. 511-573-020	1
9	435-370-020	FITTING, Elbow, 1/8 NPT x 1/4 inch tube	1
10	412-380-020	TEE, 1/4 NPT	1
11	509-365-030	CHECK VALVE ASSEMBLY	1
12	435-370-030	FITTING, Elbow, 1/4 inch male pipe x 1/4 inch tube	1
13	509-223-000	SPUD, Union	1
14	509-224-000	NUT, Union	1
15	509-208-000	BODY, Blowout	1
16+		TUBING, Copper, 1/4 inch outer diameter x 0.030 wall	4 ft
--	511-573-020	BLOWOUT SWITCH ASSEMBLY	1
--	560-900-270 *	BLOWOUT DISCS, Bag of 6, 1450 psi	1

* See Table 6-1 for other disc pressure ratings.

+ Tubing purchased separately

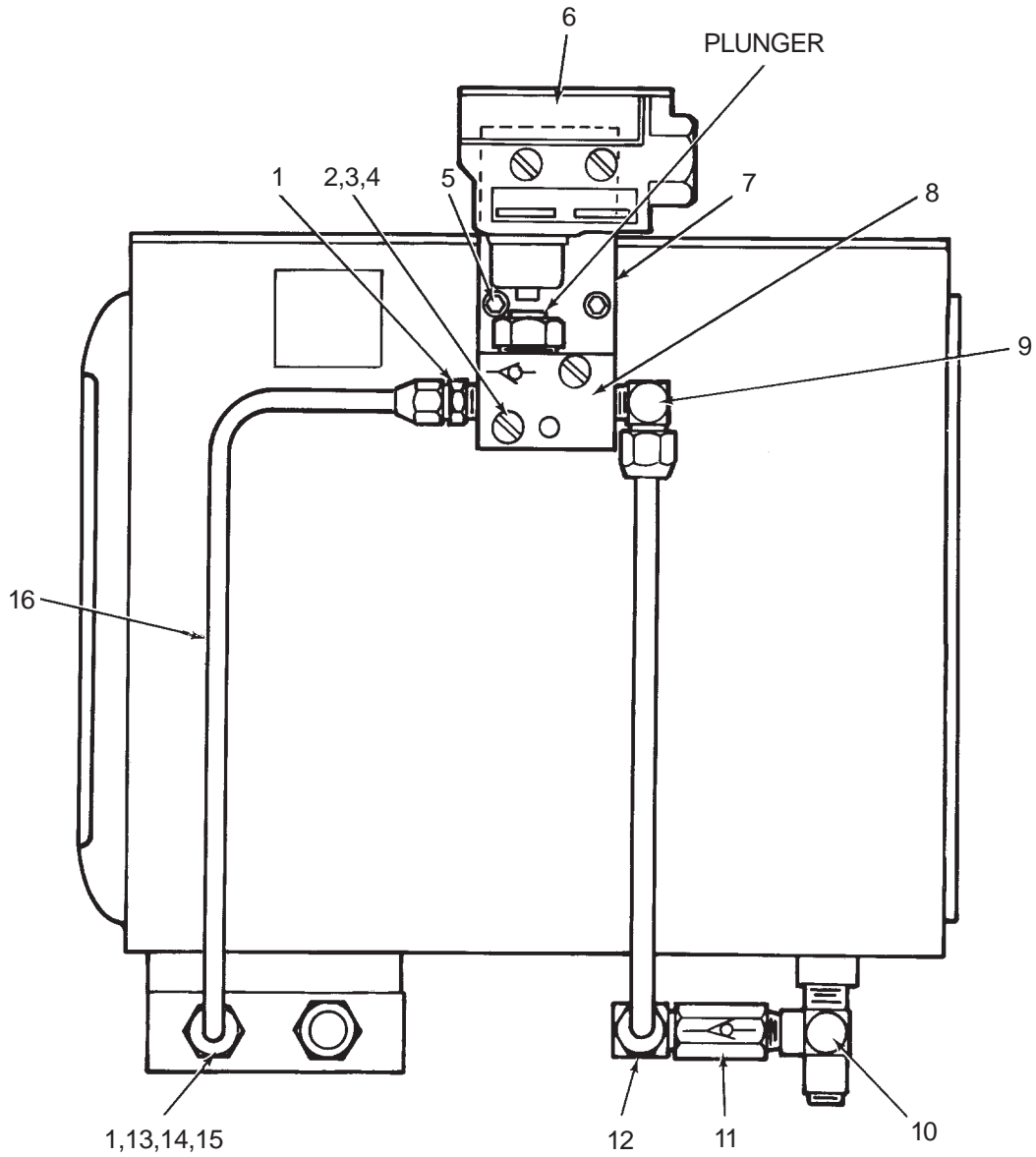

Figure 6-4. Tank Blowout Switch Assembly (Side View)

OPERATION AND SERVICE INSTRUCTIONS

Modu-Flo® System

SECTION 7

PNEUMATIC SOLENOID

7.1 DESCRIPTION 7-1
 7.2 OPERATION 7-1
 7.3 INSTALLATION 7-1

7.1 DESCRIPTION

The Pneumatic Solenoid Valve option S1 is designed for use in 115 VAC applications, while the S2 option is for 24 VDC applications. The solenoid valve is supplied with the selection plate in a normally closed configuration, making the solenoid a two way valve. It comes equipped with a manual override operator and with 18 inch long #18 AWG coil lead wires.

7.2 OPERATION

When voltage is applied to the solenoid coil, the valve is opened, allowing air to flow through to the pump manifold

and to the pneumatic piston in the pump. As air is being supplied, the pneumatic piston moves forward and pushes the lube piston forward which discharges lubricant to the system. When voltage is dropped out, air flow is stopped. The pneumatic and lube piston are returned by the piston return spring, thus allowing the pump to reprime for the next cycle.

7.3 INSTALLATION

Installing the solenoid valve to the pump manifold requires making sure the o-rings (4) are in place. Mount the solenoid valve to the pump manifold port stamped "SA" with the valve bolt. Torque to 10-15 ft. lbs.

Table 7-1. Pneumatic Solenoid Parts List

Item Number	Part Number	Description	Quantity
	521-001-020	115 VAC SOLENOID ASSEMBLY (S1)	
	521-002-100	24 VDC SOLENOID ASSEMBLY (S2)	
1	521-000-540	115 VAC SOLENOID VALVE WITH COIL	1
	521-004-550	24 VDC SOLENOID VALVE WITH COIL	1
2	521-000-550	MANIFOLD BLOCK	1
3	521-000-560	BOLT-MOUNTING	1
4	422-010-160	O-RING	2
5	416-060-120	SCREW-#8-32 X 1-1/4	2
6	521-000-542	NO/NC "PORT PLATE", PART OF ITEM 1	1

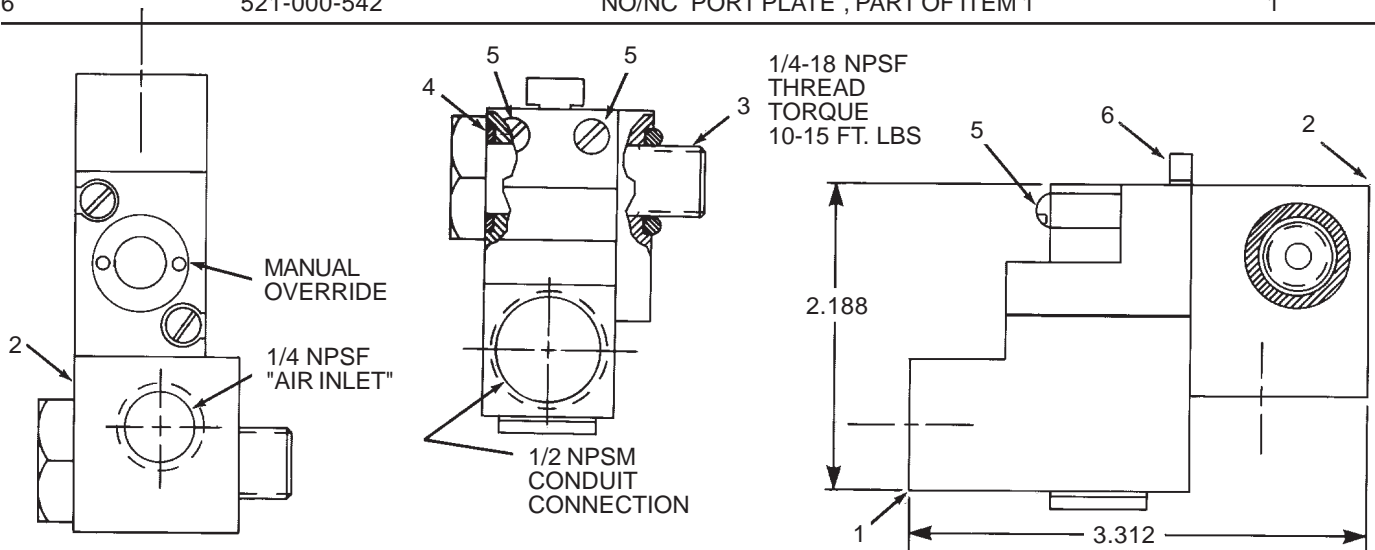

Figure 7-1. Pneumatic Solenoid

OPERATION AND SERVICE INSTRUCTIONS

Modu-Flo® System

SECTION 8

CONTROLLERS

8.1 DESCRIPTION	8-1	8.2 WIRING	8-2
8.1.1 DC Timer	8-1	8.2.1 DC Timer	8-2
8.1.2 AC Timer	8-1	8.2.2 AC Timer	8-2
8.1.3 TC-1000 Timer/Counter	8-1	8.2.3 TC-1000 Timer/Counter	8-3
8.1.4 WMP Maxi-Monitor	8-1	8.2.4 Maxi-Monitors	8-3

8.1 DESCRIPTION

8.1.1 DC Timer. The DC timer is a solid-state, 12 to 32 VDC unit that energizes a DC solenoid when it is time to start a lubrication cycle. The solenoid actuates the lubrication pump. The interval between cycles is adjustable from 1 to 10 minutes in eight steps. The duration of the lubrication cycle is not adjustable and is 30 seconds long. The DC Timer also features elapsed-time memory to ensure that the interval between cycles is maintained during equipment shutdown. A manual run button simplifies startup, testing, and venting of lubrication lines and points. The manual run button initiates one 30 second cycle each time it is depressed. Refer to Paragraph 8.2.1 for installation instructions. Refer to bulletin 14511 for additional information.

8.1.2 AC Timer. The AC timer is a solid-state, 115/230 VAC, 50/60 Hz unit that energizes a solenoid valve when it is time to start a lubrication cycle. The solenoid valve (See Paragraph 8.1.1) activates the lubrication pump. The total cycle time is adjustable from 0.5 minute to 32 hours. The duration of the lubrication pump cycle is adjustable from 12 seconds to 13 minutes. The AC timer has a built-in memory to keep the timer active for 1-1/2 hours during power failures and machine shutdowns. This feature eliminates the prelube cycle when power is reapplied after short shutdowns. A manual run button simplifies startup, testing, and bleeding of lubrication lines and points. When the manual run button is depressed, it resets the system to the beginning of the cycle and signals the pump to run for the duration of the lubrication cycle. Refer to Paragraph 8.2.2 for installation instructions. Refer to bulletin 14521 for additional information.

8.1.3 TC-1000 Timer/Counter. The TC-1000 Solid State Timer/Counter is a microprocessor based multi-use controller dedicated to the operation of centralized lubrication systems.

The TC-1000 schedules lube frequency either on a time or stroke/cycle basis in values ranging from 1-9999. The pump run interval is also selectable in time or counts over the same range.

The TC-1000 is easily programmed in the field using four mini push-buttons. No special training or knowledge of computer language is necessary. During power down or outage, data is saved in EEPROM (Electrically Erasable Programmable Read Only Memory). When power is restored, counting and pump status is restored to values prior to loss of power.

Available for 115 VAC, 230 VAC, 12 VDC, or 24 VDC operation. Pump Output voltage is the same as supply voltage.

Refer to bulletin 14530 for additional information.

8.1.4 WMP Maxi-Monitor. The WMP Maxi-Monitor is designed to control and monitor a lubrication system and its accessories. It can be used to schedule and monitor the operation of lubrication pumps and divider valves in automatic lubrication systems. The WMP is available in AC or DC power source models.

8.1.4.1 The WMP Maxi-Monitor controls lubrication schedules on either a time or a machine cycle/stroke count basis. It will also continuously monitor and display the status of the lubrication system it is controlling. It is capable of shutting down a machine and lubrication system to protect it from a loss of lubrication.

8.1.4.2 The WMP Maxi-Monitor is easily programmed. No special training or knowledge of computer languages is needed. Programming is done through a membrane keypad located on the enclosure door.

Refer to bulletins 14750 and 14752 for additional information.

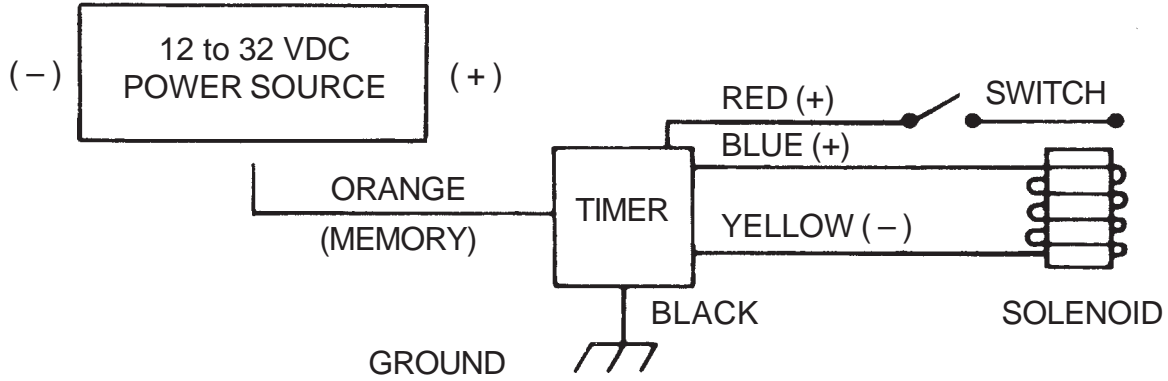

Figure 8-1. DC Timer Wiring Schematic

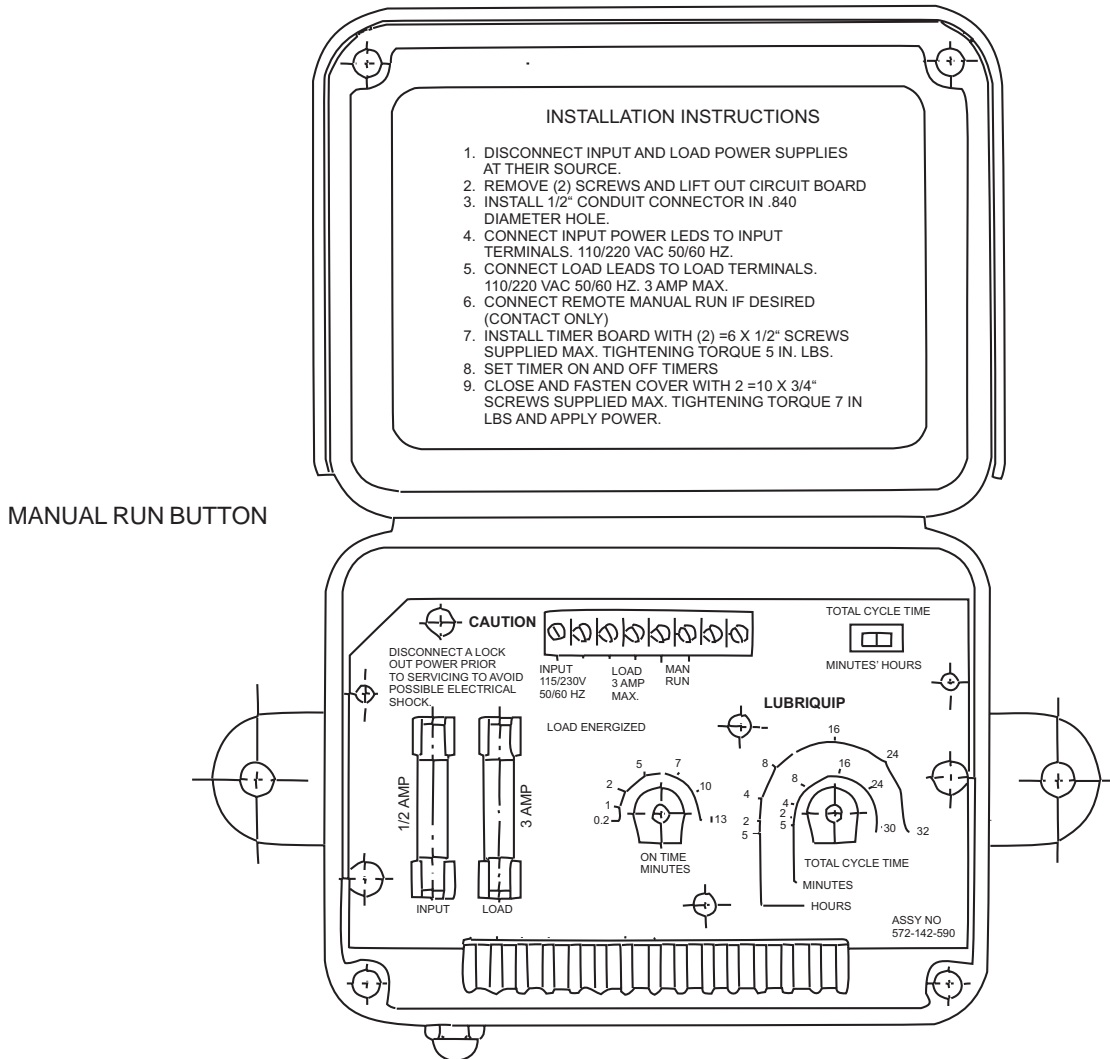

Figure 8-2. AC Timer Wiring Schematic

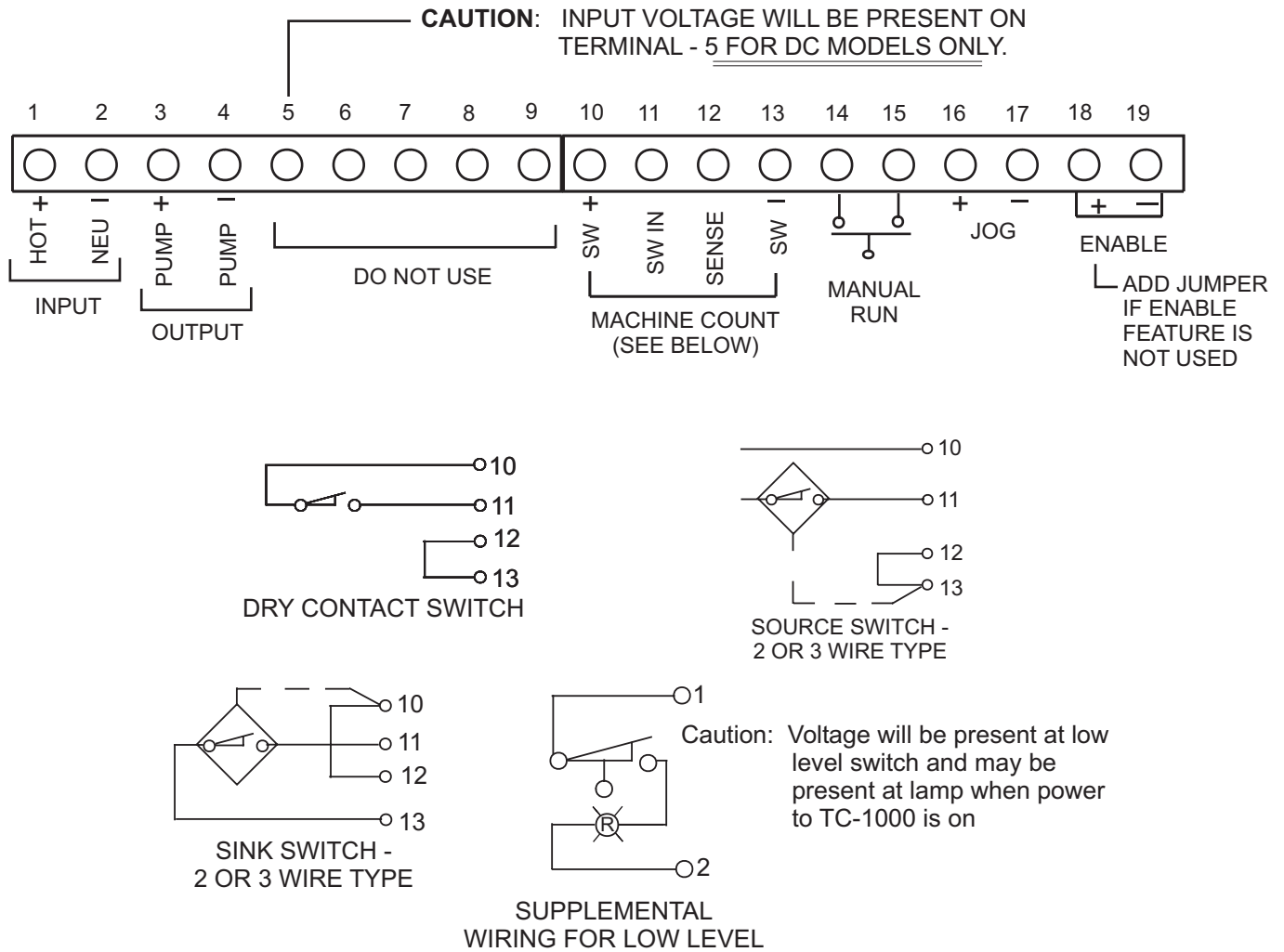

Figure 8-3. TC-1000 Timer/Counter Wiring Schematic

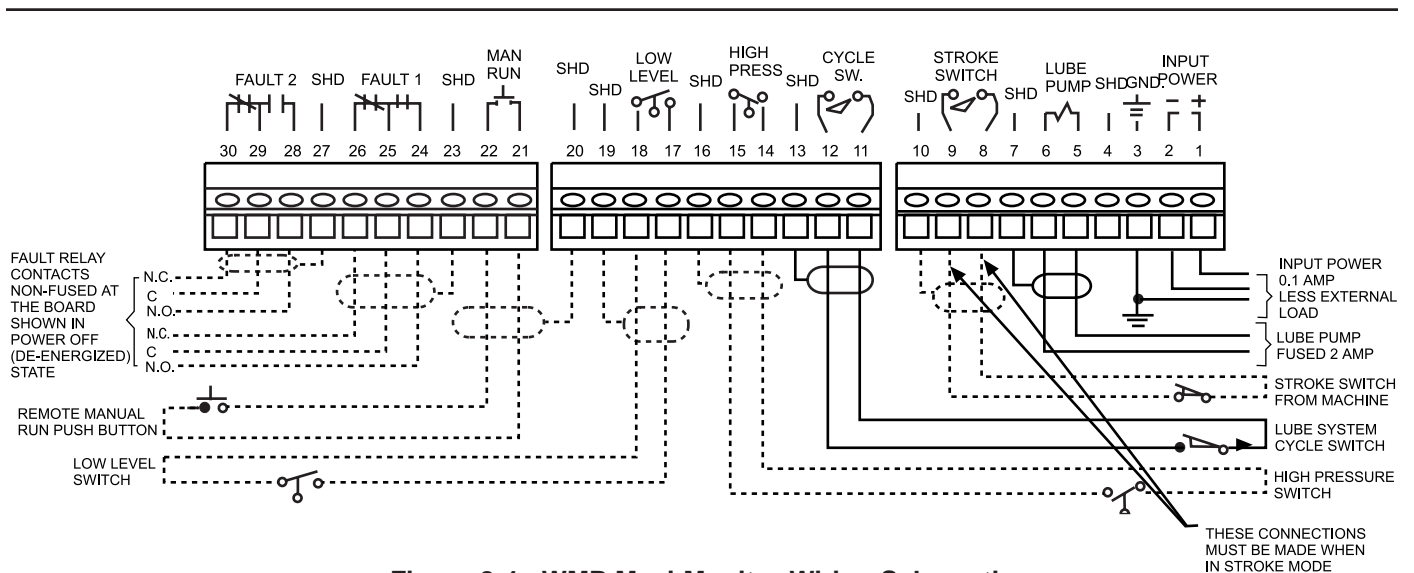

Figure 8-4. WMP Maxi-Monitor Wiring Schematic

OPERATION AND SERVICE INSTRUCTIONS

Modu-Flo® System

SECTION 9

SYSTEM OPERATION

9.1 GENERAL	9-1	9.3 OPERATING TIPS	9-1
9.2 SYSTEM INFORMATION	9-1	9.3.1 General	9-1
9.2.1 System Setup	9-1	9.4 MATERIAL CONSIDERATIONS	9-2
9.2.2 System Filling	9-1	9.4.1 Material Cleanliness	9-2
9.2.3 System Bleeding	9-1	9.4.2 Temperature Effects	9-2
9.2.4 System Start-up	9-1		

9.1 GENERAL

9.1.1 This section describes operating procedures for a Modu-Flo System. Detailed descriptions of the system components are covered in Sections 1 through 8.

9.2 SYSTEM INFORMATION

9.2.1 System Setup.

9.2.1.1 Before attempting to operate any system, check the following:

- a. Check that the reservoir or tank is securely fastened to a vertical surface. Make sure that the fill cup or grease-fill fitting may be easily reached.
- b. Check that the manifold is securely connected to the base of the reservoir or tank. If a remote manifold is used, make sure it is securely fastened to a vertical surface, and tubing or hose is connected from the reservoir to the manifold inlet.
- c. Check that the pump is securely fastened to the manifold.
- d. Check all electrical connections to any solenoids, controllers, level switches or pressure switches used on the system.
- e. Check that all accessories plumbed into the manifold are secure. Make sure all hose or tubing connections are tight.

9.2.2 System Filling. The reservoirs or tanks should be filled as described in Section 2 of this manual. To fill the remainder of the system, attach a hand pump to the system fill check valve on the manifold and cycle the hand pump until the system is filled.

9.2.3 System Bleeding. Proper filling of the system will reduce the chance of air entrapment. The manifold/pump

assembly still must be bled to remove air which will be trapped inside the pump. To do this, loosen the setscrew in the TEST port while the pump is in the dispense stroke. Tighten the setscrew before the pump reloads. Lubricant should come out of the vent hole when the pump is dispensing. Cycle the pump several times until air-free lubricant is dispensed out of the bleed hole, then tighten the setscrew.

9.2.4 System Start-up. Before starting any system, make sure that all filling and bleeding steps have been completed. Refer to Bulletin 30103 for filling and bleeding a series progressive system. Check the pneumatic or hydraulic inlet pressure and verify that it is adjusted correctly. The actual setting will vary from system to system depending on type of lubricant used and other system variables. The correct pressure for any particular system will be determined during initial setup of the system and should not need to be changed.

9.2.4.1 Check the output of the lubricant pump. Adjust the output as described in Section 3 of this manual.

9.2.4.2 The system is now ready to run. The pump is cycled by an external source, such as a timer, counter, control package, or customer-supplied directional valve. Once this external source is engaged, the system will cycle as programmed.

9.3 OPERATING TIPS

9.3.1 General. While the system is operating the following components may be checked:

9.3.1.1 Check that the pump is cycling according to schedule. The solenoid or directional valve which operates the pumps should be actuated by the system controller.

9.3.1.2 Visually check the system for leaks and loose fittings. Make sure that hoses do not become kinked and are not rubbing on anything.

9.3.1.3 If the reservoir or tank is not equipped with low-level switch, visually check the lubricant level and refill before all lubricant is used. If the reservoir or tank is allowed to run dry, air will be introduced into the system, requiring that the system be bled.

9.4 MATERIAL CONSIDERATIONS

9.4.1 Material Cleanliness. System life and consistent operation will both be improved by using only clean lubricant. On all pumps, the lube piston diameter is very close to the diameter of the chamber in the pump body. Contaminants in the lubricant could cause scoring in this area, resulting in

erratic pump operation and costly parts replacement. Make sure that lubricant used to fill the system is clean. If there is doubt about cleanliness, lubricant should be filtered before being introduced into the system. After filtering the system, make sure the lubricant supply is protected from debris. For protection of divider valves and the equipment being lubricated, an in-line filter (oil) or strainer (grease) should be installed between this pump and the first stage (master) divider.

Lubriquip recommends a minimum oil cleanliness level of ISO 18/14 per ISO standard 4406 for all oil systems. Lubriquip further recommends that all grease systems be equipped with a 100 mesh strainer. Refer to bulletin 15200 for available lubricant filters and strainers.

9.4.2 Temperature Effects. Flow characteristics of the lubricant may change if the area the Modu-Flo system is used in goes through drastic temperature changes. Choose a lubricant that will flow properly at all temperatures expected in the system environment.

**OPERATION AND
SERVICE INSTRUCTIONS**

**Modu-Flo®
System**

SECTION 10

TROUBLESHOOTING

10.1 GENERAL 10-1

10.1 GENERAL

10.1.1 Many system problems may be caused by loose connections or air trapped in the system. Before removing system components, it is a good practice to check all connections to make sure they are tight. Also make sure the

system is properly bled. Table 10-1 lists some of the problems which may occur in the Modu-Flo system along with possible causes and corrective actions. Disassembly and assembly procedures for the system components are contained in other sections of this manual and should be referred to if a component needs servicing.

Table 10-1. Modu-Flo Troubleshooting

Problem	Possible Cause	Corrective Action
A. No lube is dispensed from pump, but pump is receiving air or hydraulic operating signals.	1. Reservoir or tank is empty.	1. Refill as required.
	2. Air or hydraulic pressure is inadequate.	2. Set pressure to proper setting.
	3. If pump is single-acting, return spring may be defective.	3. Replace spring or change pump to double-acting. (Refer to Section 3.)
	4. Pump needs servicing.	4. Disassemble pump and replace defective components. (Refer to Section 3.)
	5. Pump adjustment screw is turned in too far.	5. Adjust pump. (Refer to Section 3.)
	6. Pump is air bound.	6. Bleed air through test port. (Refer to Figure 4-1).
B. Blow-out disc has ruptured.	1. High pressure exists in the system.	1. Inspect dividers, lines, fittings, and lube points to determine the source of high pressure. Correct problem and replace disc.
	2. Excessive air or hydraulic flow to pump.	2. Install a restrictor in the air or hydraulic lines.
C. Pump output is erratic.	1. System is not properly bled.	1. Bleed system.
	2. Pump needs servicing.	2. Disassemble pump and replace defective components. (Refer to Section 3.)
	3. Pump adjustment assembly is leaking or sucking air during return stroke.	3. Tighten components of the adjustment assembly.
	4. Defective o-ring.	4. Repair pump or manifold. (Refer to Sections 3 and 4.)
	5. Setscrew and ball are loose in TEST port.	5. Tighten setscrew.

Table 10-1. Modu-Flo Troubleshooting - Continued

Problem	Possible Cause	Corrective Action
D. Pump is not receiving signal to operate.	1. Electrical connections to solenoid or timer are defective.	1. Check all connections and tighten securely.
	2. Timer or controller is set incorrectly or is defective.	2. Set timer or controller to correct setting. If unit is still not functioning consult factory for assistance.
	3. Pneumatic or hydraulic power supply is turned off.	3. Turn on power supply.

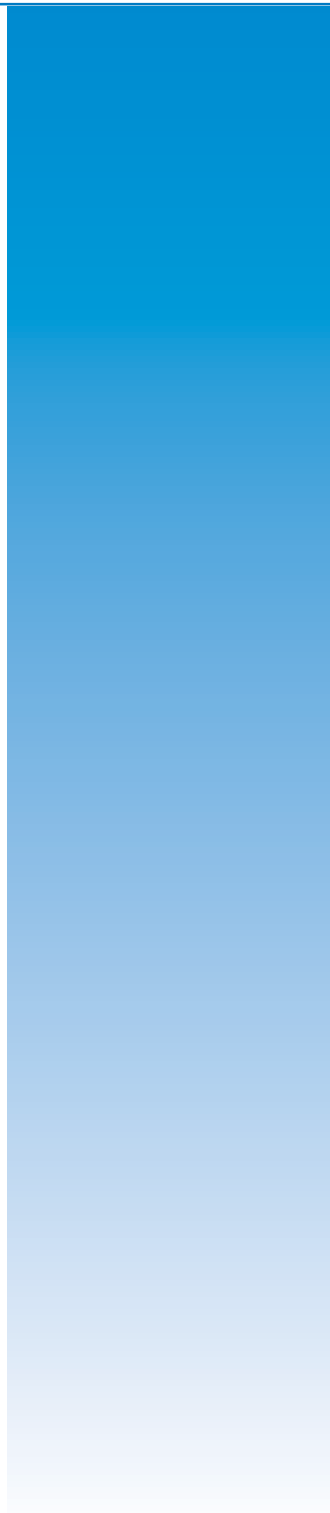

ISO 9001
REGISTERED FIRM

ISO 14001
REGISTERED FIRM

**Look to LUBRIQUIP, Inc.
for all of your
Centralized Lubrication System needs.**

Products include:

DIVIDER VALVES: for oil and grease...to 7500 PSI...
1 to 20 points form a single valve assembly...up to 400
points from a Master/Secondaries circuit...or systems
that handle an entire plant.

PUMPS: fixed and variable displacement...manual and
air, hydraulic, electric motor or mechanically driven.

TIMERS/AUTOMATIC CONTROLS: from simple on/off
to complete flow and pressure monitoring, either timer-or
machine-actuated.

ACCESSORY VALVES: balancing, check and flow.

INDICATORS: performance and broken line.

ACCESSORIES: fittings, brackets, clamps, filters
and stariners

© Registered trademark of LUBRIQUIP, INC.,
Printed in U.S.A.