

Operating Instructions

PROFIBUS-PA/-DP

Field Communication for Smartec S CLD132/134

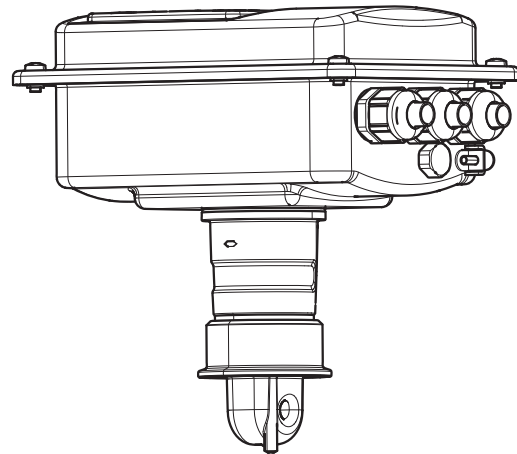
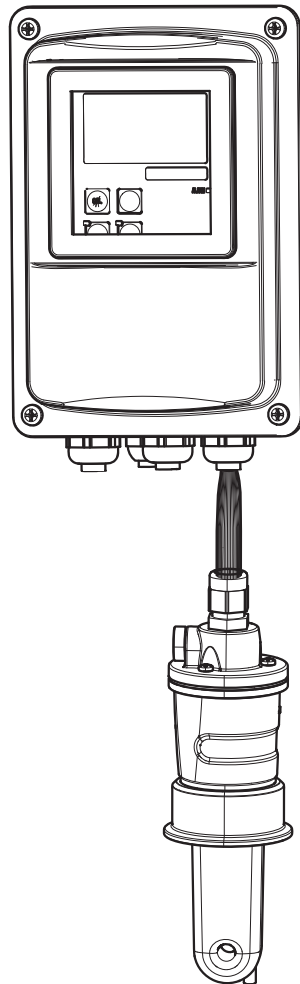

About this document

Safety messages

The structure, signal words and safety colors of the signs comply with the specifications of ANSI Z535.6 ("Product safety information in product manuals, instructions and other collateral materials").

Safety message structure	Meaning
⚠ DANGER Cause (/consequences) Consequences if safety message is not heeded ▶ Corrective action	This symbol alerts you to a dangerous situation. Failure to avoid the situation will result in a fatal or serious injury.
⚠ WARNING Cause (/consequences) Consequences if safety message is not heeded ▶ Corrective action	This symbol alerts you to a dangerous situation. Failure to avoid the situation can result in a fatal or serious injury.
⚠ CAUTION Cause (/consequences) Consequences if safety message is not heeded ▶ Corrective action	This symbol alerts you to a dangerous situation. Failure to avoid this situation can result in minor or medium injury.
NOTICE Cause/situation Consequences if safety message is not heeded ▶ Action/note	This symbol alerts you to situations that can result in damage to property and equipment.

Symbols





-  Additional information, tips
-  Permitted or recommended
-  Forbidden or not recommended

Table of contents

1	Basic safety instructions	4
1.1	Requirements for the personnel	4
1.2	Designated use	4
1.3	Workplace safety	4
1.4	Operational safety	4
1.5	Product safety	5
2	Installation	6
2.1	System equipment	6
2.2	Post-installation check	7
3	Wiring	8
3.1	Electrical connection	8
3.2	Post-connection check	10
4	Operability	11
4.1	Display and operating elements	11
4.2	Operation via FieldCare	11
5	System integration	12
5.1	Block model of PROFIBUS PA/DP	12
5.2	Cyclical data exchange (Data_Exchange)	18
5.3	Acyclical data exchange	22
6	Commissioning	30
6.1	Function check	30
6.2	Setting of device address	30
6.3	Device data and type files	32
7	Diagnostics and troubleshooting	35
8	Accessories	37
9	Technical data	39
9.1	Output PROFIBUS-PA	39
9.2	Output PROFIBUS-DP	39
9.3	Display and user interface	40
9.4	Standards and guidelines	40
	Index	42

1 Basic safety instructions

1.1 Requirements for the personnel

- ▶ Installation, commissioning, operation and maintenance of the measuring system must only be carried out by trained technical personnel.
 - ▶ The technical personnel must be authorized by the plant operator to carry out the specified activities.
 - ▶ The electrical connection may only be performed by an electrical technician.
 - ▶ The technical personnel must have read and understood these Operating Instructions and must follow the instructions they contain.
 - ▶ Measuring point faults may only be rectified by authorized and specially trained personnel.
-  Repairs not described in the enclosed Operating Instructions may only be carried out directly at the manufacturer's or by the service organization.

1.2 Designated use

These Operating Instructions were designed specifically for use with transmitters of the family Smartec S CLD132/134. They contain specific information for instruments with the PROFIBUS PA interface (**Process Field Bus - Process Automation**) or the PROFIBUS DP interface (**Process Field Bus - Decentralized Peripherals**). PROFIBUS is an open field bus standard according to IEC 61158 / IEC 61784. It has been created specifically for process control purposes and permits connection of several measuring instruments to a bus line. The transmission method according to IEC 1158-2 guarantees safe signal transmission.

The PROFIBUS PA interface permits operation of the instrument from the PC:

- via FieldCare (Plant Asset Management Tool)

Any other use than the one described here compromises the safety of persons and the entire measuring system and is not permitted.

The manufacturer is not liable for damage caused by improper or non-designated use.

1.3 Workplace safety

As the user, you are responsible for complying with the following safety conditions:

- Regulations for explosion protection
- Installation instructions
- Local standards and regulations

Electromagnetic compatibility

With regard to electromagnetic compatibility, this device has been tested in accordance with the applicable European standards for industrial applications.

The electromagnetic compatibility indicated only applies to a device that has been connected in accordance with the instructions in these Operating Instructions.

1.4 Operational safety

- ▶ Before commissioning the entire measuring point, make sure all the connections are correct. Ensure that electrical cables and hose connections are not damaged.
- ▶ Do not operate damaged products, and safeguard them to ensure that they are not operated inadvertently. Mark the damaged product as defective.
- ▶ If faults cannot be rectified, the products must be taken out of service and secured against unintentional commissioning.

1.5 Product safety

The product is designed to meet state-of-the-art safety requirements, has been tested and left the factory in a condition in which it is safe to operate. Relevant regulations and European standards have been observed.

2 Installation

2.1 System equipment

A complete system architecture comprises:

- Transmitter Smartec S CLD132 or CLD134
- Segment coupler (PA only)
- PROFIBUS termination
- Cabling incl. bus distributor
- either
 - PC with FieldCare or
 - Programmable logic controller (PLC)

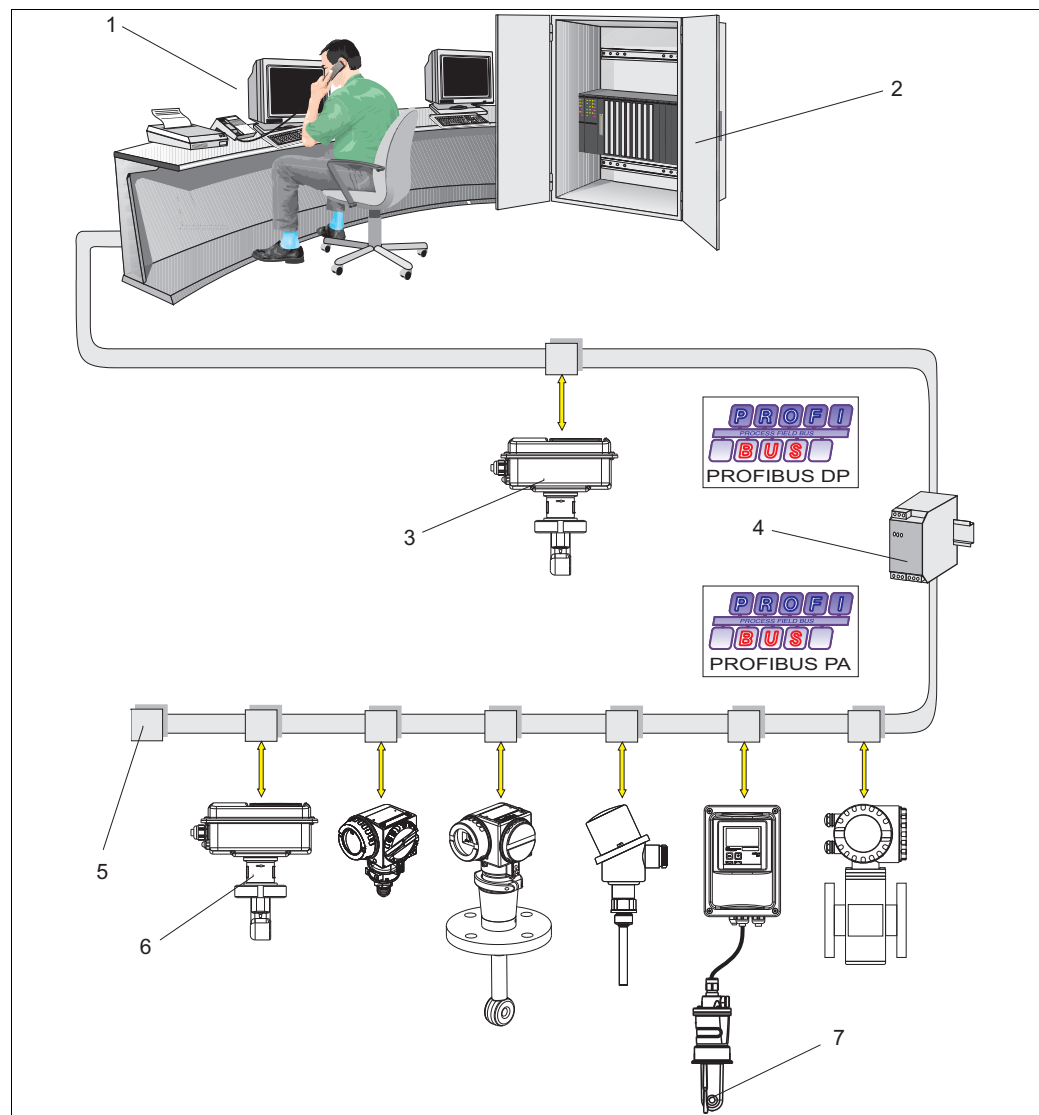

Fig. 1: Measuring systems with PROFIBUS interface

- 1 PC with PROFIBUS interface
- 2 PLC
- 3 Smartec S CLD132/134 PROFIBUS DP compact version
- 4 Segment coupler
- 5 Termination
- 6 Smartec S CLD132/134 PROFIBUS PA compact version
- 7 Smartec S CLD132/134 PROFIBUS PA separate version with CLS52/54

The maximum number of transmitters in a bus segment is determined by their power consumption, the bus coupler output and the required bus length.

- For detailed information on function and connection of a PROFIBUS system, please refer to Technical Information TI00260F/00/en

2.2 Post-installation check

- After installation, check the transmitter for damage.
- Check whether the transmitter is protected against moisture and direct sunlight (e.g. by the weather protection cover).

3 Wiring

⚠ WARNING

Device is energized

Improper connection can cause injury or death.

- ▶ The electrical connection must only be carried out by a certified electrician.
- ▶ Technical personnel must have read and understood the instructions in this manual and must adhere to them.
- ▶ **Prior to beginning** any wiring work, make sure voltage is not applied to any of the cables.

3.1 Electrical connection



Proceed as follows to connect the bus cable to the transmitter:

1. Loosen the 4 Phillips screws on the housing cover and remove the cover.

⚠ WARNING

Instrument is energized

Improper connection can cause injury or death.

- ▶ Make sure the instrument is disconnected from the power source before you remove the cover frame.
2. Remove the cover frame from the terminal blocks. To do this, introduce a screwdriver in the recess (A) according to →  2 and push the tab inward (B).
 3. Thread the cables through the open cable glands into the connection compartment.
 4. **Cable connection for PA devices:** Connect the cable wires of the bus cable in accordance with →  3 to the terminal block. Mixing up the polarity of the PA+ and PA- connections does not have any influence on operation. The bus cable can be connected to the PA device via the Pg cable gland or an M12 plug.
 5. **Cable connection for DP devices:** Connect the cable wires of the bus cable in accordance with →  7 to the terminal block.
 6. Tighten the cable gland.
 7. Close the housing cover.

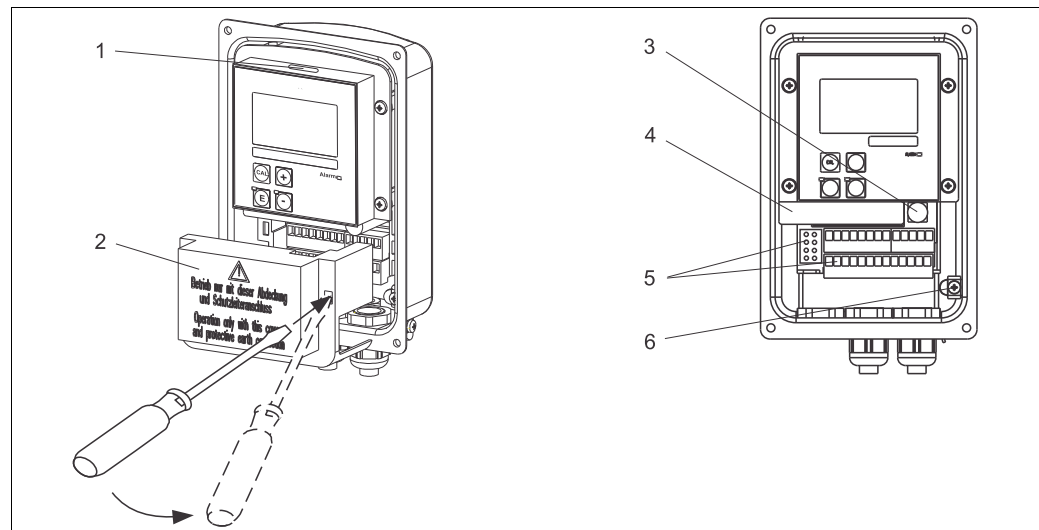

Fig. 2: Bus cable connection Smartec S PROFIBUS

- | | |
|---|---------------------------|
| 1 | Port for DIL switch |
| 2 | Cover frame |
| 3 | Fuse |
| 4 | Removable electronics box |
| 5 | Terminals |
| 6 | Housing ground |

PA device

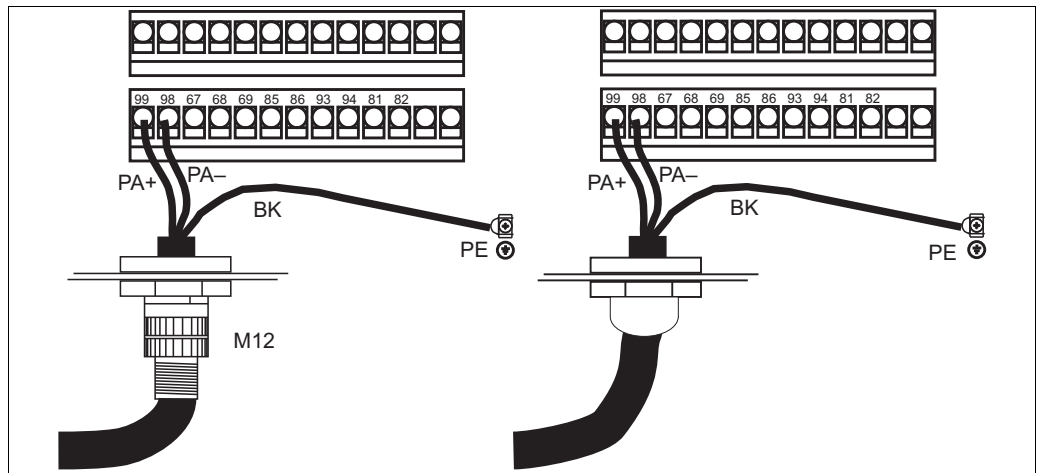

Fig. 3: PA device electrical connection

DP device

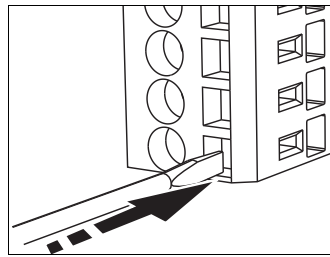

Fig. 4: Insert the screwdriver (opens the terminal)

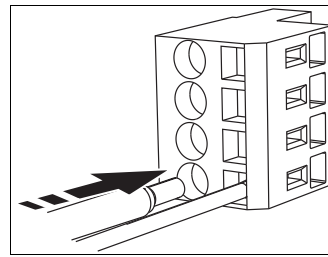

Fig. 5: Insert the cable until the limit stop

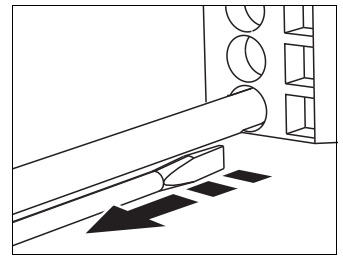

Fig. 6: Remove the screwdriver (closes the terminal)

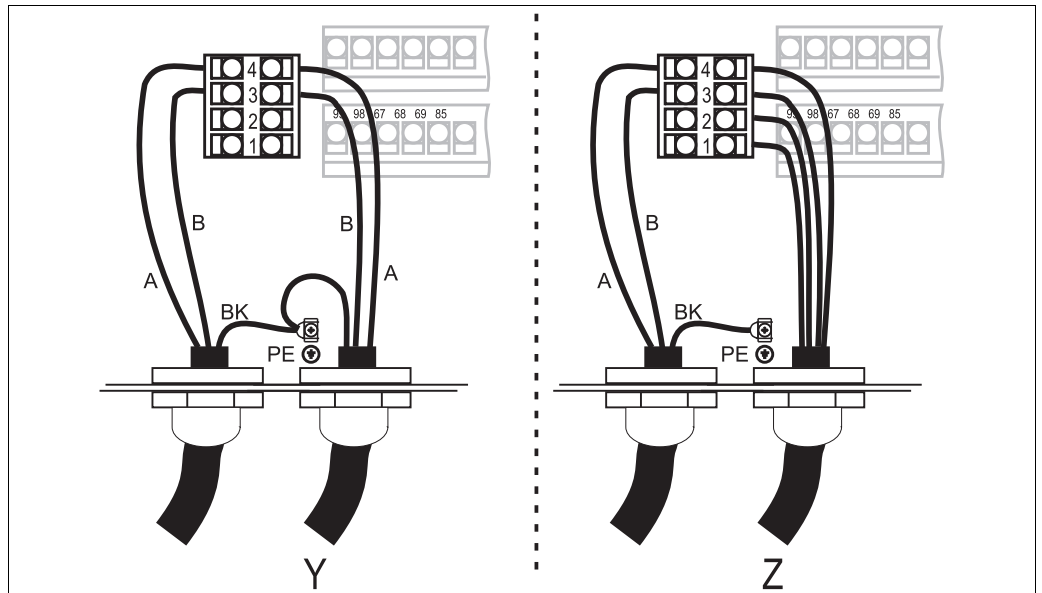

Fig. 7: DP device electrical connection

- 1 GND
- 2 Power supply +5 V for bus termination
- 3 B (Rx/D / Tx/D-P)
- 4 A (Rx/D / Tx/D-N)
- Y Next PROFIBUS device
- Z Bus termination

The remaining connection (sensor, power supply etc.) are described in the standard Operating Instructions (BA00207C/07/EN for CLD132, BA00401C/07/EN for CLD134).

Bus termination

The bus terminations for PROFIBUS PA and DP are different.

Each PROFIBUS PA segment must be terminated with a **passive** bus termination on each end.

Each PROFIBUS DP segment must be terminated with an **active** bus termination on each end.

3.2 Post-connection check

After the electrical connection, carry out the following checks:

Device condition and specifications	Notes
Are the transmitter and cables damaged on the outside?	Visual inspection

Electrical connection	Notes
Are the mounted cables strain relieved?	
Cable run without loops and cross-overs?	
Are the signal lines correctly connected in accordance with the wiring diagram?	
Are all screw terminals tightened?	
Are all cable entries installed, tightened and sealed?	

4 Operability

4.1 Display and operating elements

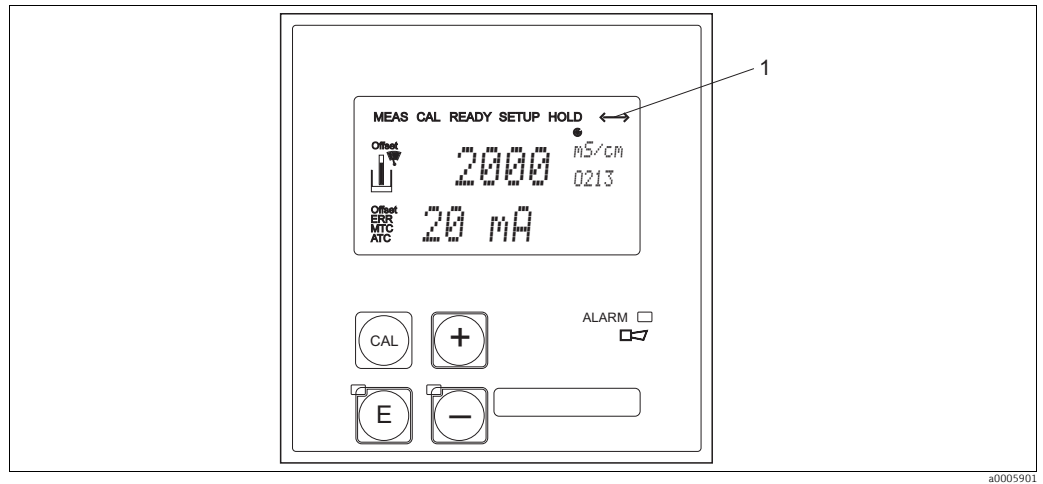

Fig. 8: User interface of Smartec S

1 Display symbol for active communication via PROFIBUS interface

Please refer to the standard Operating Instructions for an explanation of the key assignment and the other icons and symbols.

4.2 Operation via FieldCare

FieldCare is Endress+Hauser's FDT-based Plant Asset Management Tool. It can configure all intelligent field devices in your plant and supports you in managing them. By using status information, it also provides a simple but effective means of checking their health.

- Supports HART and PROFIBUS
- Operates all Endress+Hauser devices
- Integrates third-party devices such as actuators, I/O systems and sensors supporting the FDT standard
- Ensures full functionality for all devices with DTMs
- Offers generic profile operation for third-party fieldbus devices that do not have a vendor DTM

i For information on FieldCare installation see the operating instructions "Getting started" BA00027S/04/a4.

5 System integration

5.1 Block model of PROFIBUS PA/DP

In the PROFIBUS configuration, all the device parameters are categorized according to their functional properties and tasks and are generally assigned to three different blocks. A block may be regarded as a container in which parameters and the associated functionalities are contained.

A PROFIBUS device has the following block types (see →  9):

- **A Physical Block (device block)**

The Physical Block contains all device-specific features of the unit.

- **One or more Transducer Blocks**

The Transducer Block contains all the measuring and device-specific parameters of the device. The measuring principles (e.g. conductivity, temperature) are depicted in the Transducer Blocks in accordance with the PROFIBUS Profile 3.0 Specification.

- **One or more function blocks**

A function block contains the automation functions of the device. The transmitter contains Analog Input blocks by means of which the measured values can be scaled and examined for limit value overshoot.

A number of automation-related tasks can be implemented with these blocks. In addition to these blocks, a transmitter can have any number of additional blocks, for example several Analog Input function blocks if the transmitter can process more than one process variable.

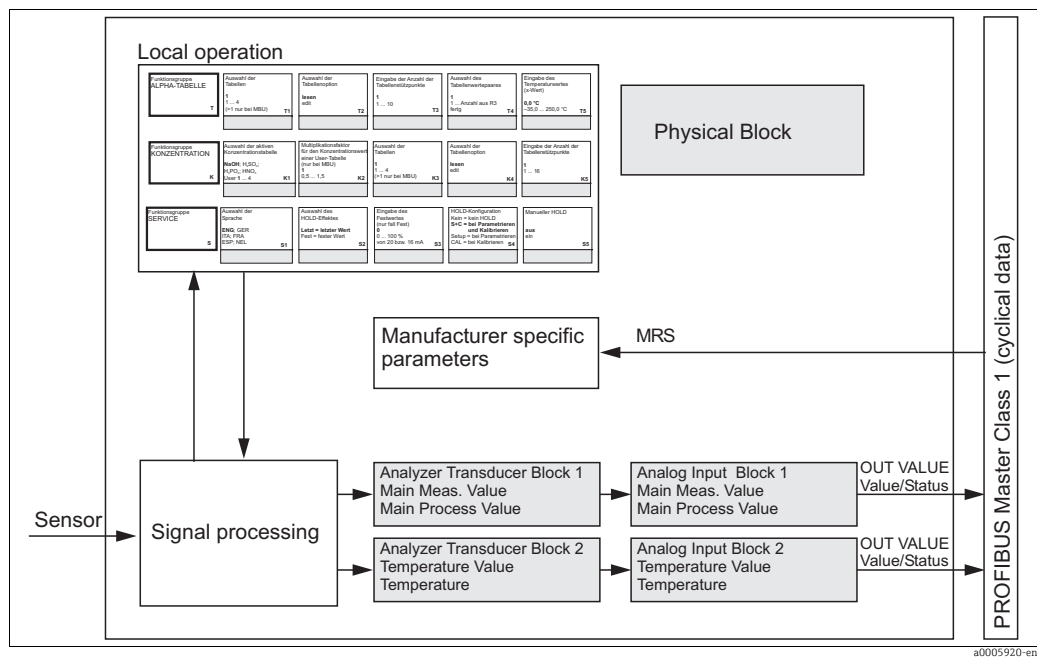

Fig. 9: Block model of Smartec S (grey = profile blocks)

a0005920-en

Physical Block (device block)

A Physical Block contains all the data that uniquely identify and characterize the transmitter. It is an electronic version of a nameplate on the transmitter. Parameters of the Physical Block are, for example, device type, device name, manufacturer's identification, serial number, etc.

A further task of the Physical Block is the management of general parameters and functions that influence the execution of the other blocks in the transmitter. The Physical Block is thus the central unit that also checks the device status and thereby influences or controls the operability of the other blocks and thus also of the device.

Write protection

- On-site hardware write protection

By pressing the "Enter" and the "Plus" keys simultaneously, you can lock the device for on-site configuration operations.

Use the "Cal" and "Minus" keys to unlock the device. You can find more information in the standard Operating Instructions under "Locking/Unlocking keypad".

- Hardware write protection via PROFIBUS

The HW_WRITE_PROTECTION parameter indicates the status of the hardware write protection. The following statuses are possible:

1: Hardware write protection enabled, device data cannot be overwritten.

0: Hardware write protection disabled, device data can be overwritten.

- Software write protection

You can also set software write protection to prevent all parameters from being acyclically overwritten. You can do so by making an entry in the WRITE_LOCKING parameter. The following entries are permitted:

2457: Device data can be overwritten (factory setting).

0: Device data cannot be overwritten.

Parameter LOCAL_OP_ENABLE

You can use the LOCAL_OP_ENABLE parameter to permit or lock local operation at the device. The following values are possible:

- 0: Deactivated.

Local operation is locked. You can only change this status via the bus.

The code 9998 is displayed in the local operation. The transmitter behaves just as with hardware write protection via the keyboard (see above).

- 1: Activated.

Local operation is active. However, commands from the master have a higher priority than local commands.

 Local operation is automatically activated if communication should fail for longer than 30 seconds.

If communication fails when local operation is locked, the device will immediately return to the locked status as soon as communication is functioning again.

Parameter PB_TAG_DESC

You can set the client-specific device number (tag number) via:

- local operation in menu field I2 (INTERFACE function group) or via
- PROFIBUS parameter TAG_DESC of the Physical Block.

If you change the tag number via one of the two options, the change can also be seen immediately at the other position.

Parameter FACTORY_RESET

You can reset the following data via the FACTORY_RESET parameter:

1	all data to PNO default values
2506	transmitter warm start
2712	bus address
32768	calibration data
32769	setting data

Via local operation you can either reset all data to the factory settings or delete the sensor data in menu field S10 (SERVICE function group).

Parameter IDENT_NUMBER_SELECTOR

You can use the IDENT_NUMBER_SELECTOR parameter to switch the transmitter between three operating modes, each of which has different functionality in relation to the cyclic data:

IDENT_NUMBER_SELECTOR	Functionality
0	Cyclic communication only possible with Profile GSD. Only standard diagnosis in cyclic data.
1 (default)	Full functionality with Profile 3.0 and extended diagnosis in cyclic data. The manufacturer-specific GSD is required.
2	Downwards compatible Profile 2.0 functionality without diagnosis in cyclic data. The manufacturer-specific Profile 2.0 GSD is required.

See also table "Device Master Files for Smartec S".

Analog Input Block (function block)

In the Analog Input function block, the process variables (conductivity and temperature) of the Transducer Block are prepared, in terms of instrumentation and control, for the subsequent automation functions (e.g. scaling, limit value processing). There are two Analog Input function blocks available for the Smartec S PROFIBUS transmitter.

Signal processing

The diagram shows a schematic of the internal structure of an Analog Input function block:

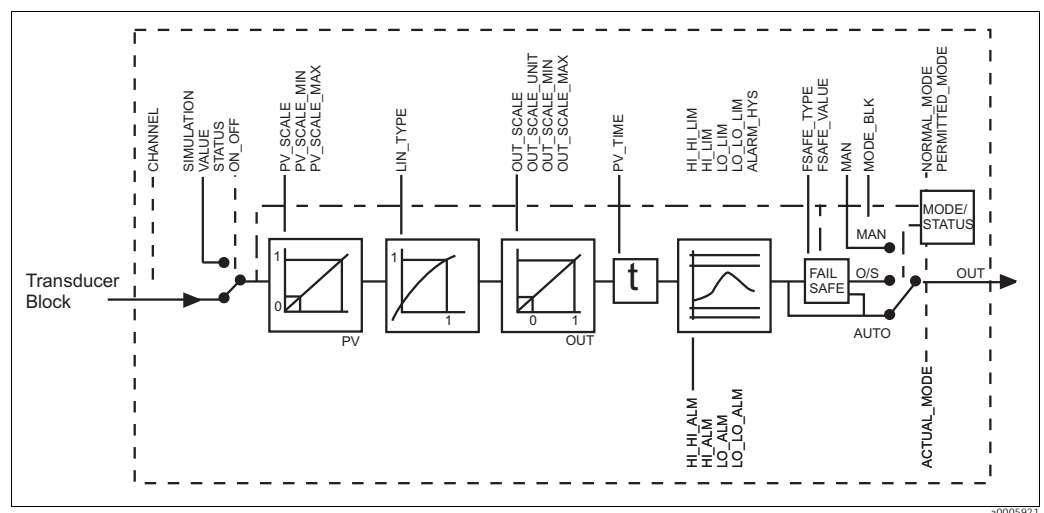

Fig. 10: Schematic internal structure of an Analog Input function block

The Analog Input function block receives its input value from the Analyzer Transducer Block. The input values are permanently assigned to each Analog Input function block:

- Main measured value (Main Process Value) – Analog Input function block 1 (AI 1)
- Measured temperature value (temperature) – Analog Input function block 2 (AI 2)

SIMULATE

In the SIMULATE parameter group you can replace the input value with a simulation value and activate simulation. By specifying the status and the simulation value, you can test the reaction of the automation system.

PV_FTIME

In the PV_FTIME parameter you can dampen the converted input value (primary value = PV) by specifying a filter time. If a time of 0 seconds is specified, the input value is not dampened.

MODE_BLK

The MODE_BLK parameter group is used to select the operating mode of the Analog Input function block. By selecting the MAN (manual) operating mode, you can directly specify the OUT output value and the OUT status.

The most important functions and parameters of the Analog Input Block are listed below.

Selecting the operating mode

The operating mode is set by means of the MODE_BLK parameter group. The Analog Input function block supports the following operating modes:

- AUTO (automatic mode)
- MAN (manual mode)
- O/S (out of service)

Selecting the units

The system unit for one of the measured values can be changed in the Analog Input Block. The way of changing the unit is to use the PV_SCALE and OUT_SCALE parameters (see "Rescaling the input value").

OUT

The OUT output value is compared to warning limits and alarm limits (e.g. HI_LIM, LO_LIM), which can be entered via diverse parameters. If one of these limit values is violated, a limit value process alarm (e.g. HI_ALM, LO_ALM) is triggered.

OUT status

The status of the Analog Input function block and the validity of the OUT output value are relayed to the downstream function blocks by means of the status of the OUT parameter group. The following status values can be displayed:

- **GOOD_NON_CASCADE**
The OUT output value is valid and can be used for further processing.
- **UNCERTAIN**
The OUT output value can only be used for further processing to a limited extent.
- **BAD**
The OUT output value is invalid. Occurs when the Analog Input function block is switched to the O/S operating mode (Out of Service) or in the event of a serious error (see status codes and system or process-specific error messages in the Operating Instructions BA207C/07/en or BA401C/07/en).

In addition to the device-internal error messages, other device functions have an influence on the status of the OUT value:

- **Automatic hold**
If "Hold" is switched on, the Out Status is set to BAD not specific (0x00).
- **Calibration**
During calibration, the OUT Status is set to the UNCERTAIN sensor calibration value (0x64) (even when hold is switched on).

Simulation of input/output

You can simulate the input and output of the function block by means of various parameters of the Analog Input function block:

1. **Simulating the input of the Analog Input function block:**
The SIMULATION parameter group can be used to specify the input value (measured value and status). Since the simulation value runs through the entire function block, you can check all the parameter settings of the block.
2. **Simulating the output of the Analog Input function block:**
Set the operating mode in the MODE_BLK parameter group to MAN and directly specify the desired output value in the OUT parameter.

Measured value simulation in local operation

In the case of measured value simulation in local operation, the status UNCERTAIN – simulated value is relayed to the function blocks. This triggers the failsafe mechanism in the AI blocks.

Error response (FSAFE_TYPE)

If an input or simulation value has the status BAD, the Analog Input function block uses the error response defined in the FSAFE_TYPE parameter. The FSAFE_TYPE parameter offers the following error response options:

- **FSAFE_VALUE**
The value specified in the FSAFE_VALUE parameter is used for further processing.
 - **LAST_GOOD_VALUE**
The last good value is used for further processing.
 - **WRONG_VALUE**
The current value is used for further processing, despite the BAD status. The default is the setting (FSAFE_VALUE) with value "0".
-  Error response is also activated if the Analog Input function block is set to the "OUT OF SERVICE" operating mode.

Rescaling the input value

In the Analog Input function block, the input value or input range can be scaled in accordance with the automation requirements.

Example:

- The system unit in the Transducer Block is °C.
- The measuring range of the device is -10 to 150 °C.
- The output range to the automation system should be 14 °F to 302 °F.
- The measured value from the Transducer Block (input value) is rescaled linearly via the input scaling PV_SCALE to the desired output range OUT_SCALE.
- Parameter group PV_SCALE
 PV_SCALE_MIN (V1H0) -10
 PV_SCALE_MAX (V1H1) 150
- Parameter group OUT_SCALE
 OUT_SCALE_MIN (V1H3) 14
 OUT_SCALE_MAX (V1H4) 302
 OUT_UNIT (V1H5) [F]

The result is that with an input value of 25 °C, for example, a value of 77 °F is output via the OUT parameter (→  11).

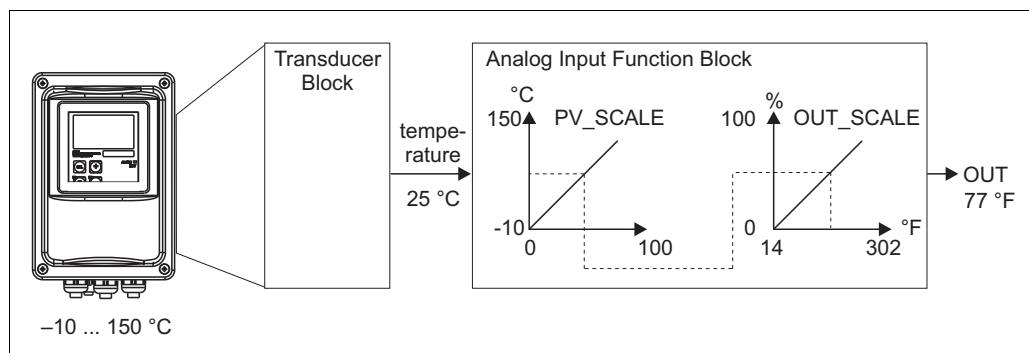

Fig. 11: Scaling the input value for the Analog Input function block

Limit values

You can set two warning limits and two alarm limits for monitoring your process. The status of the measured value and the parameters of the limit-value alarms are indicative of the measured value's relative position. You also have the option of defining an alarm hysteresis in order to avoid frequent changes of the limit-value flags and frequent enabling/disabling of alarms.

The limit values are based on the OUT output value. If the OUT output value exceeds or undershoots the defined limit values, the automation system is alarmed via the limit value process alarms (see below).

The following limit values can be defined:

- HI_LIM, HI_HI_LIM
- LO_LIM, LO_LO_LIM

Alarm detection and processing

Limit value process alarms are generated by the Analog Input function block. The status of the limit value process alarms is communicated to the automation system by means of the following parameters:

- HI_ALM, HI_HI_ALM
- LO_ALM, LO_LO_ALM

5.2 Cyclical data exchange (Data_Exchange)

The Smartec S provides the following modules as input data (data from transmitter to PLC) for the cyclic data telegram:

Input data (data from transmitter to PLC)

- Main Process Value
This byte transfers the main measured value.
- Temperature
This byte transfers the temperature.

Structure of the input data (Smartec S to PLC)

The input data is transferred from the transmitter in the following structure:

Index Input Data	Data	Access	Data format	Configuration data
0...4	Analog Input Block 1 "Main Process Value"	read	Measured value (32-bit floating point number; IEEE-754) Status byte (0x80) = Ok	0x42, 0x84, 0x08, 0x05 or 0x42, 0x84, 0x81, 0x81 or 0x94
5...9	Analog Input Block 2 "Temperature"	read	Measured value (32-bit floating point number; IEEE-754) Status byte (0x80) = Ok	0x42, 0x84, 0x08, 0x05 or 0x42, 0x84, 0x81, 0x81 or 0x94

Output data (data from PLC to transmitter)

- MRS (Measuring Range Switch)
This byte transfers the external hold and the parameter set switch from the PLC to the transmitter.

Structure of the output data (PLC to Smartec S)

The output data of the PLC for device control have the following structure:

Index Input Data	Data	Access	Data format	Configuration data
0	MRS	write	Byte Status byte (0x80) = Ok	0x42, 0x84, 0x08, 0x05 or 0x42, 0x84, 0x81, 0x81 or 0x94

PROFIBUS processes data in hexadecimal code and converts them into 4 bytes (each 8 bits, 4x8=32 bits).

In accordance with IEEE 754, a number has three components:

- Sign (S)
The sign requires exactly 1 bit and has the values 0 (+) or 1(-).
Bit 7 of the 1st byte of a 32-bit floating-point number defines the sign.
- Exponent
The exponent is composed of bits 6 to 0 of the 1st byte plus bit 7 of the 2nd byte (= 8 bits).
- Mantissa
The remaining 23 bits are used for the mantissa.

Byte 1								Byte 2								Byte 3								Byte 4												
7	6	5	4	3	2	1	0	7	6	5	4	3	2	1	0	7	6	5	4	3	2	1	0	7	6	5	4	3	2	1	0					
V	2 ⁻⁷	2 ⁻⁶	2 ⁻⁵	2 ⁻⁴	2 ⁻³	2 ⁻²	2 ⁻¹	2 ⁻¹	2 ⁻²	2 ⁻³	2 ⁻⁴	2 ⁻⁵	2 ⁻⁶	2 ⁻⁷	2 ⁻⁸	2 ⁻⁹	2 ⁻¹⁰	2 ⁻¹¹	2 ⁻¹²	2 ⁻¹³	2 ⁻¹⁴	2 ⁻¹⁵	2 ⁻¹⁶	2 ⁻¹⁷	2 ⁻¹⁸	2 ⁻¹⁹	2 ⁻²⁰	2 ⁻²¹	2 ⁻²²	2 ⁻²³						
S	Exponent							Mantissa																												

Formula (IEEE 754): Value = (-1)^{VZ} * 2^(exponent - 127) * (1 + Mantissa)

Example: 40 F0 00 00 = 0 10000001 1110000 00000000 00000000
 (hexadecimal) Byte 1 Byte 2 Byte 3 Byte 4

Value = (-1)⁰ * 2^(129 - 127) * (1 + 2⁻¹ + 2⁻² + 2⁻³)
 = 1 * 2² * (1 + 0.5 + 0.25 + 0.125)
 = 1 * 4 * 1.875
 = 7.5

Explanation of measuring range switch (MRS)

MRS										Function
reserved	reserved	reserved	reserved	reserved	reserved	E2	E1	decimal	hexadecimal	
number of binary inputs = 2; E1 and E2 active										
-	-	-	-	-	-	0	0	0	0x00	MRS 1
-	-	-	-	-	-	0	1	1	0x01	MRS 2
-	-	-	-	-	-	1	0	2	0x02	MRS 3
-	-	-	-	-	-	1	1	3	0x03	MRS 4
number of binary inputs = 1; E1 and E2 active										
-	-	-	-	-	-	0	0	0	0x00	MRS 1
-	-	-	-	-	-	-	1	1	0x01	Hold on
-	-	-	-	-	-	1	0	2	0x02	MRS 2
number of binary inputs = 0; E1 active										
-	-	-	-	-	-	-	0	-	0x00	Hold off
-	-	-	-	-	-	-	1	1	0x01	Hold on

Customizing the cyclic data telegram

You can customize the cyclic telegram to better meet the requirements of a process. The tables above represent the maximum contents of the cyclic data telegram.

If you do not want to use all output variables of the transmitter, you can use the device configuration (CHK_CFG) to eliminate individual data blocks from the cyclic telegram via the PLC software. Shortening the telegram improves the data throughput rate of a PROFIBUS system. You should only keep those blocks active which you process further in the system. You can do this by means of a "negative" selection in the configuration tool.

To achieve the correct structure of the cyclic data telegram, the PROFIBUS master must send the identification FREE_PLACE (00h) for the non-active blocks.

Status codes for the OUT parameter of the Analog Input block

Status code	Device status	Meaning	Limits
0x00 0x01 0x02 0x03	BAD	non-specific	OK LOW_LIM HIGH_LIM CONST
0x04 0x05 0x06 0x07	BAD	configuration error	OK LOW_LIM HIGH_LIM CONST
0x0C 0x0D 0x0E 0x0F	BAD	device failure	OK LOW_LIM HIGH_LIM CONST
0x10 0x11 0x12 0x13	BAD	sensor failure	OK LOW_LIM HIGH_LIM CONST
0x1F	BAD	out of service	CONST
0x40 0x41 0x42 0x43	UNCERTAIN	non-specific	OK LOW_LIM HIGH_LIM CONST
0x47	UNCERTAIN	last usable value	CONST
0x4B	UNCERTAIN	substitute set	CONST
0x4F	UNCERTAIN	initial value	CONST
0x50 0x51 0x52 0x53	UNCERTAIN	sensor conversion not accurate	OK LOW_LIM HIGH_LIM CONST
0x5C 0x5D 0x5E 0x5F	UNCERTAIN	configuration error	OK LOW_LIM HIGH_LIM CONST
0x60 0x61 0x62 0x63	UNCERTAIN	simulated value	OK LOW_LIM HIGH_LIM CONST

Status code	Device status	Meaning	Limits
0x64 0x65 0x66 0x67	UNCERTAIN	sensor calibration	OK LOW_LIM HIGH_LIM CONST
0x80 0x83	GOOD	ok	OK CONST
0x84 0x85 0x86 0x87	GOOD	update event	OK LOW_LIM HIGH_LIM CONST
0x89 0x8A	GOOD	active advisory alarm	LOW_LIM HIGH_LIM
0x8D 0x8E	GOOD	active critical alarm	LOW_LIM HIGH_LIM

5.3 Acyclical data exchange

Acyclic data exchange is used to transfer parameters during commissioning, during maintenance or to display other measured variables that are not contained in the cyclic user data traffic.

Generally, a distinction is made between Class 1 and Class 2 master connections. Depending on the implementation of the transmitter, it is possible to simultaneously establish several Class 2 connections.

- Two Class 2 masters are permitted with Smartec S. This means that two Class 2 masters can access the transmitter at the same time. However, you must make certain that they do not both attempt to *write* to the same data. Otherwise the data consistency can no longer be guaranteed.
- When a Class 2 master reads parameters, it sends a request telegram to the transmitter specifying the device address, the slot/index and the expected record length. The transmitter answers with the requested record if the record exists and has the correct length (byte).
- When a Class 2 master writes parameters, it transmits the address of the transmitter, the slot and index, length information (byte) and the record. The transmitter acknowledges this write job after completion.

Slot/index tables

The device parameters are listed in the following tables. You can access these parameters by means of the slot and index number.

Each individual block comprises standard parameters, block parameters and manufacturer-specific parameters to an extent.

Device management

Parameter	E+H Matrix	Slot	Index	Size (bytes)	Type	Acc.	Store
DIR_OBJECT HEADER		1	0	12	Array of unsigned16	r	Cst.
COMP_LIST_DIR_ENTRIES		1	1	32	Array of unsigned16	r	Cst.
COMP_DIR_ENTRIES_CONTINUES		1	2	12	Array of unsigned16	r	Cst.

Physical Block

Parameter	E+H Matrix	Slot	Index	Size (bytes)	Type	Acc.	Store
Standard parameter							
BLOCK_OBJECT		1	160	20	DS-32*	r	C
ST_REV		1	161	2	Unsigned16	r	N
TAG_DESC	VAH0	1	162	32	Octetstring	r, w	S
STRATEGY		1	163	2	Unsigned16	r, w	S
ALERT_KEY		1	164	1	Unsigned8	r, w	S
TARGET_MODE		1	165	1	Unsigned8	r, w	S
MODE_BLK Actual Permitted Normal		1	166	3	DS-37* Unsigned8 Unsigned8 Unsigned8	r	N Cst Cst
ALARM_SUM		1	167	8	DS-42*	r	D
Blockparameter							
SOFTWARE_REVISION		1	168	16	Visible string	r	Cst
HARDWARE_REVISION		1	169	16	Visible string	r	Cst
DEVICE_MAN_ID		1	170	2	Unsigned16	r	Cst
DEVICE_ID		1	171	16	Visible string	r	Cst
DEVICE_SER_NUM		1	172	16	Visible string	r	Cst
DIAGNOSIS		1	173	4	Octetstring	r	D
DIAGNOSIS_EXTENSION		1	174	6	Octetstring	r	D
DIAGNOSIS_MASK		1	175	4	Octetstring	r	Cst
DIAGNOSIS_MASK_EXTENSION		1	176	6	Octetstring	r	Cst
DEVICE_CERTIFICATION		1	177	32	Visible string	r	N
WRITE_LOCKING		1	178	2	Unsigned16 0: acyclic refused 2457: writeable	r, w	N
FACTORY_RESET		1	179	2	Unsigned16 0x8000: reset calibration data 0x8001: reset set data 0x0001: PNO defaults all data 2506: warm start 2712: reset bus adr.	r, w	S

Parameter	E+H Matrix	Slot	Index	Size (bytes)	Type	Acc.	Store
DESCRIPTOR		1	180	32	Octetstring	r, w	S
DEVICE_MESSAGE		1	181	32	Octetstring	r, w	S
DEVICE_INSTALL_DATE		1	182	16	Octetstring	r, w	S
LOCAL_OP_ENABLE		1	183	1	Unsigned8 0: disabled 1: enabled	r, w	N
IDENT_NUMBER_SELECTOR		1	184	1	Unsigned8 0: profile specific 1: manufacturer specific P 3.0 2: manufacturer specific P2.0	r, w	S
HW_WRITE_PROTECTION		1	185	1	Unsigned8 0: unprotected 1: protected	r	D
DEVICE_CONFIGURATION		1	196	32	Visible string	r	N
INIT_STATE		1	197	1	Unsigned8 1: status before reset 2: run 5: maintenance	r, w	S
DEVICE_STATE		1	198	1	Unsigned8 2: run 5: maintenance	r, w	D
GLOBAL_STATUS		1	199	2	Unsigned16	r	D
Gap		1	200 - 207				
E+H-Parameter							
ACTUAL_ERROR	VAH2	1	208	2	Unsigned16	r	D
LAST_ERROR	VAH3	1	209	2	Unsigned16	r	D
UPDOWN_FEATURES_SUPP		1	210	1	Octetstring	r	C
DEVICE_BUS_ADDRESS	VAH1	1	213	1	Signed8	r	N
SET_UNIT_TO_BUS	VAH9	1	214	1	Unsigned8 0: off 1: confirm	r, w	D
CLEAR_LAST_ERROR	VAH4	1	215	1	Unsigned8 0: off 1: confirm	r, w	D

Analyzer Transducer Block

There are two Analyzer Transducer Blocks in the SmarTec S. These are distributed to slots 1 and 2 in the following order:

1. Main measured value (Main Process Value)
2. Measured temperature value (Temperature)

Parameter	E+H Matrix	Slot	Index	Size (bytes)	Type	Acc.	Store
Standard parameter							
BLOCK_OBJECT		1 - 2	100	20	DS-32*	r	C
ST_REV		1 - 2	101	2	Unsigned16	r	N
TAG_DESC		1 - 2	102	32	Octetstring	r, w	S
STRATEGY		1 - 2	103	2	Unsigned16	r, w	S
ALERT_KEY		1 - 2	104	1	Unsigned8	r, w	S
TARGET_MODE		1 - 2	105	1	Unsigned8	r, w	S
MODE_BLK Actual Permitted Normal		1 - 2	1016	3	DS-37* Unsigned8 Unsigned8 Unsigned8	r	N Cst Cst
ALARM_SUM		1 - 2	107	8	DS-42*	r	D
Block parameter							
COMPONENT_NAME		1 - 2	108	32	Octetstring	r, w	S
PV		1 - 2	109	12	DS-60*	r	D
PV_UNIT		1 - 2	110	2	Unsigned16	r, w	S
PV_UNIT_TEXT		1 - 2	111	8	Visible string	r, w	S
ACTIVE_RANGE		1 - 2	112	1	Unsigned8 1: Range 1	r, w	S
AUTORANGE_ON		1 - 2	113	1	Boolean	r, w	S
SAMPLING_RATE		1 - 2	114	4	Time_difference	r, w	S
Gap reserved PNO		1 - 2	115 - 124				
NUMBER_OF_RANGES		1 - 2	125	1	Unsigned8	r	N
RANGE_1		1 - 2	126	8	DS-61*	r, w	N

Analog Input Block

There are two Analog Input Blocks in the Smartec S transmitter. These are distributed to slots 1 and 2 in the following order:

1. Main measured value (Main Process Value)
2. Measured temperature value (Temperature)

Parameter	E+H Matrix	Slot	Index	Size (bytes)	Type	Acc.	Store
Standard parameter							
BLOCK_OBJECT		1 - 2	16	20	DS-32*	r	C
ST_REV		1 - 2	17	2	Unsigned16	r	N
TAG_DESC		1 - 2	18	32	Octetstring	r, w	S
STRATEGY		1 - 2	19	2	Unsigned16	r, w	S
ALERT_KEY		1 - 2	20	1	Unsigned8	r, w	S
TARGET_MODE		1 - 2	21	1	Unsigned8	r, w	S
MODE_BLK Actual Permitted Normal		1 - 2	22	3	DS-37* Unsigned8 Unsigned8 Unsigned8	r	N Cst Cst
ALARM_SUM		1 - 2	23	8	DS-42*	r	D
BATCH		1 - 2	24	10	DS-67*	r, w	S
Gap		1 - 2	25				
Block parameter							
OUT		1 - 2	26	5	DS-33*	r	D
PV_SCALE		1 - 2	27	8	Float	r, w	S
OUT_SCALE		1 - 2	28	11	DS-36*	r, w	S
LIN_TYPE		1 - 2	29	1	Unsigned8	r, w	S
CHANNEL		1 - 2	30	2	Unsigned16	r, w	S
PV_FTIME		1 - 2	32	4	Float	r, w	S
FSAFE_TYPE		1 - 2	33	1	Unsigned8	r, w	S
FSAFE_VALUE		1 - 2	34	4	Float	r, w	S
ALARM_HYS		1 - 2	35	4	Float	r, w	S
HI_HI_LIM		1 - 2	37	4	Float	r, w	S
HI_LIM		1 - 2	39	4	Float	r, w	S
LO_LIM		1 - 2	41	4	Float	r, w	S
LO_LO_LIM		1 - 2	43	4	Float	r, w	S
HI_HI_ALM		1 - 2	46	16	DS-39*	r	D
HI_ALM		1 - 2	47	16	DS-39*	r	D
LO_ALM		1 - 2	48	16	DS-39*	r	D
LO_LO_ALM		1 - 2	49	16	DS-39*	r	D
SIMULATE		1 - 2	50	6	DS-50*	r, w	S
VIEW_1		1 - 2	61	18	Unsigned8	r	D

Manufacturer-specific parameters Smartec S

Parameter	E+H Matrix	Slot	Index	Size (bytes)	Type	Acc.	Store
Measured value	V0H0	3	100	4	Float	r	D
Temperature	V0H1	3	101	4	Float	r	D
Operating mode	V0H2	3	102	1	Unsigned8 0: Conductivity 1: Concentration	r	D
Unit of measurement (concentration)	V0H3	3	103	1	Unsigned8 57: % 139: ppm 245: mg/l 106: tds 251: without	r, w	N
Number of decimal places	V0H4	3	104	1	Unsigned8 0: X.xxx 1: XX.xx 2: XXX.x 3: XXXX	r, w	N
Unit of measurement (conductivity)	V0H5	3	105	1	Unsigned8 66: mS/cm 67: µm/cm 240: S/m	r, w	N
Signal damping	V0H6	3	106	1	Unsigned8	r, w	N
Raw value	V0H7	3	107	4	Float	r	D
Current measuring range	V0H9	3	108	1	Unsigned8	r, w	N
Temperature measurement	V1H0	3	109	1	Unsigned8 0: fixed 1: Pt 100 2: Pt 1000 3: NTC	r, w	N
Process temperature	V1H3	3	110	4	Float	r, w	N
Cell constant	V1H4	3	111	4	Float	r, w	N
Installation factor	V1H6	3	112	4	Float	r, w	N
Calibration temperature	V1H8	3	113	4	Float	r, w	N
Temperature correction	V1H9	3	114	4	Float	r, w	N
Contact function	V3H0	3	115	1	Unsigned8 0: Alarm function 1: Limit function 2: Limit + alarm fct.	r, w	N
Switch-on delay	V3H3	3	116	2	Unsigned16	r, w	N
Switch-off delay	V3H4	3	117	2	Unsigned16	r, w	N
Number of binary inputs	V4H0	3	118	1	Unsigned8	r, w	N
Source of binary inputs	V4H1	3	119	1	Unsigned8 0: binary contacts 1: cyclic data	r, w	N
Processed measuring range	V4H2	3	120	1	Unsigned8	r, w	N
Operating mode of processed measuring range	V4H3	3	121	1	Unsigned8 0: Conductivity 1: Concentration	r, w	N
Substance selection of processed measuring range	V4H4	3	122	1	Unsigned8 0: NaOH 1: H2SO4 2: H3PO4 3: HNO3 4: User 1...	r, w	N

Parameter	E+H Matrix	Slot	Index	Size (bytes)	Type	Acc.	Store
Temperature compensation of processed measuring range	V4H5	3	123	1	Unsigned8 0: without 1: linear 2: NaCl 3: User 1...	r, w	N
Alpha value of processed measuring range	V4H6	3	124	4	Float	r, w	N
Switch-on point of processed measuring range	V4H8	3	125	4	Float	r, w	N
Switch-off point of processed measuring range	V4H9	3	126	4	Float	r, w	N
Correction factor	V5H0	3	127	4	Float	r, w	N
Substance selection	V5H1	3	128	1	Unsigned8 0: NaOH 1: H2SO4 2: H3PO4 3: HNO3 4: User 1...	r	D
Current concentration table	V5H2	3	129	1	Unsigned8	r, w	D
Read/edit concentration table	V5H3	3	130	1	Unsigned8 0: read 1: edit	r, w	D
Number of concentration table elements	V5H4	3	131	1	Unsigned8	r, w	N
Selection of concentration table elements	V5H5	3	132	1	Unsigned8	r, w	D
Conductivity concentration table	V5H6	3	133	4	Float	r, w	N
Concentration concentration table	V5H7	3	134	4	Float	r, w	N
Temperature concentration table	V5H8	3	135	4	Float	r, w	N
Status concentration table	V5H9	3	136	1	Unsigned8 0: Ok 1: Service 2: Processing 3: Invalid	r	D
Current alpha table	V6H0	3	137	1	Unsigned8 1: User	r, w	D
Read/edit alpha table	V6H1	3	138	1	Unsigned8 0: read 1: edit	r, w	D
Number of alpha table elements	V6H2	3	139	1	Unsigned8	r, w	N
Selection of alpha table elements	V6H3	3	140	1	Unsigned8	r, w	D
Temperature alpha table	V6H4	3	141	4	Float	r, w	N
Alpha value alpha table	V6H5	3	142	4	Float	r, w	N
Status alpha table	V6H6	3	143	1	Unsigned8 0: Ok 1: Service 2: Processing 3: Invalid	r	D
PCS alarm	V7H0	3	144	1	Unsigned8 0: no PCS 1: 1 hour 2: 2 hours 3: 4 hours	r, w	N

Parameter	E+H Matrix	Slot	Index	Size (bytes)	Type	Acc.	Store
Relaiy contact type	V8H1	3	145	1	Unsigned8 0: steady contact 1: fleeting contact	r, w	N
Relay time unit	V8H2	3	146	1	Unsigned8 0: seconds 1: minutes	r, w	N
Alarm delay	V8H3	3	147	2	Unsigned16	r, w	N
Diagnostic code selection	V8H4	3	148	1	Unsigned8	r, w	D
Alarm status	V8H5	3	149	1	Unsigned8 0: no 1: yes	r	D
Alarm relay	V8H6	3	150	1	Unsigned8 0: no 1: yes	r, w	N
Security locking	V8H9	3	151	2	Unsigned16 22: not protected 9998: loc. op. disabl. 9999: hardware prot.	r, w	N
Hold function	V9H0	3	152	1	Unsigned8	r, w	N
Hold dwell period	V9H1	3	153	2	Unsigned16	r, w	N
MRS version	V9H2	3	154	1	Unsigned8	r	Cst
Factory values	V9H4	3	155	1	Unsigned8 1: Device data 2: Sensor data 3: User data 4: Address data	r, w	D
SW version	VAH5	3	156	2	Unsigned16	r	Cst
HW version	VAH6	3	157	2	Unsigned16	r	Cst

Data strings

Some data types in the slot/index table (e. g. DS-33) are marked with a asterisk (*). These data types are data strings which are structured as per the PROFIBUS Specification Part 1, Version 3.0. They consist of several elements which are additionally addressed via a sub-index, as shown in the following example.

Parameter type	Sub-index	Type	Size (byte)
DS-33	1	Float	4
	5	Unsigned8	1

6 Commissioning

6.1 Function check

▲ WARNING

Incorrect connection, incorrect supply voltage

Safety risks for staff and incorrect operation of the device

- ▶ Check that all connections have been established correctly in accordance with the wiring diagram.
- ▶ Make sure that the supply voltage matches the voltage indicated on the nameplate.

6.2 Setting of device address

The address must be set for each PROFIBUS device. The process control system does not recognize the transmitter if the address is not set correctly.

All devices have the address 126 on leaving the factory. You can use this address for device function checking and for connection to a PROFIBUS PA network. You must change this address to be able to integrate additional devices.

The device address can be set via:

- Local operation
- PROFIBUS communication
- DIL switch in the device

- i** Valid device addresses are in the range 0 to 125.
Each address may only be given once in a PROFIBUS network.
The double arrow in the display indicates active communication with PROFIBUS.

Position of the DIL switch



Fig. 12: Position of the DIL switch (only accessible with open housing cover)

You can only set the address via the software if DIL switch 8 is set to "ON". The factory setting of the DIL switch is "ON" (→  13).

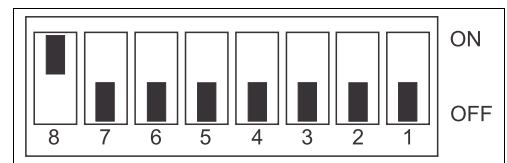
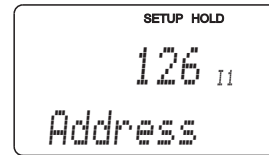

Fig. 13: Factory setting of the DIL switch

Set the device address via the INTERFACE function group in menu field I1.



Setting the device address via PROFIBUS communication

The address is set via the Set_Slave_Add service.

Setting the device address via DIL switch (hardware setting)

Please proceed as follows to set the device address:

1. Loosen the four Phillips screws and remove the housing cover. The DIL switch is situated on the electronic module above the display.
2. Set the device address (from 0 to 126) at switches 1 to 7.
Example: 18 = 2 + 16 (switch 2 and switch 5 = ON)
3. Set switch 8 to "OFF".
4. Close the housing cover.

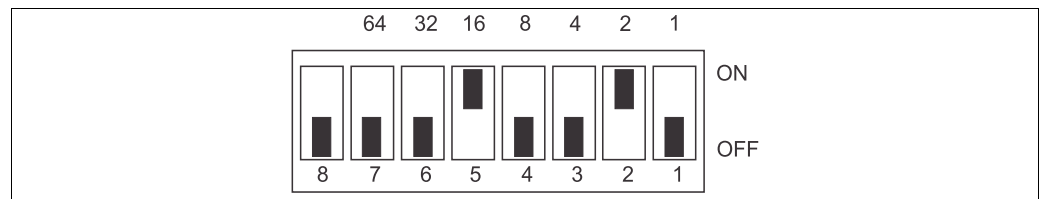



Fig. 14: Hardware setting of the device address (example address = 18)

6.3 Device data and type files

The device data base (GSD) is required to configure a PROFIBUS DP network. The GSD (a simple text file) describes e. g. which data transfer rate is supported by the device or which digital information in which format the PLC receives from the device.

Each device is assigned an ID number by the PROFIBUS use organization (PNO). The name of the device data base (GSD) is derived from this ID number.

 For Endress+Hauser devices the ID number always starts with "15XX".

Types of Device Master Files

 Prior to configuration, decide which GSD you want to use to operate the system. You can change the setting by means of a Class 2 master (under Physical Block - Parameter Ident_Number_Selector).

Generally, the following Device Master Files with different functionalities are available to you:

- **Manufacturer-specific GSD with Profile 3.0 functionality:**

This GSD guarantees the unlimited functionality of the field device. Device-specific process parameters and functions are therefore available.

- **Manufacturer-specific GSD with Profile 2.0 functionality:**

This GSD guarantees downward compatibility to the Smartec S transmitter with Profile 2.0 functionality. With this you can use the Smartec S transmitter with Profile 3.0 functionality even in applications with Smartec S transmitter with Profile 2.0 functionality.

- **Profile GSD**

If a system is configured with profile GSDs, it is possible to exchange devices that are supplied by various manufacturers. It is, however, essential that the cyclic process values follow the same sequence.

Example:

The Smartec S transmitter supports the profile GSD *PA139750.gsd* (IEC 61158-2). This GSD comprises AI blocks. The AI blocks are always assigned to the following measured variables:

AI 1 = Main process value

AI 2 = Temperature

This guarantees that the first measured variable agrees with the field devices of other manufacturers.

Name of device	ID no.	GSD	Ident_Number_Selector	Bitmaps
Smartec S - only Profile 3.0 functionality:				
Smartec S PA	9750 Hex	PA139750.gsd	0	PA_9750n.bmp
Smartec S DP	9750 Hex	PA039750.gsd	0	PA_9750n.bmp
Smartec S - manufacturer-specific functions with Profile 2.0 functionality:				
Smartec S PA additional cycl. data for digital I/O (parameter set switch)	153E Hex	EH3x153E.gsd	1	EH153E_d.bmp EH153E_n.bmp EH153E_s.bmp
Smartec S DP additional cycl. data for digital I/O (parameter set switch)	153D Hex	EH3x153D.gsd	1	EH153D_d.bmp EH153D_n.bmp EH153D_s.bmp
Smartec S - manufacturer-specific functions with Profile 2.0 functionality:				
Smartec S PA	151B Hex	EH__151B.gsd	2	EH151B_d.bmp EH151B_n.bmp EH151B_s.bmp
Smartec S DP	151A Hex	EH__151A.gsd	2	EH151A_d.bmp EH151A_n.bmp EH151A_s.bmp

The GSD files for all Endress+Hauser devices can be obtained from the following sources:

- Via the Internet:
 - E+H: <http://www.endress.com>
 - PNO: <http://www.profibus.com>
- On CD-ROM from E+H; order no. 56003894

Contents of the download file and of CD-ROM:

- All Endress+Hauser GSD files
- All Endress+Hauser bitmap files
- Useful information on the devices

Content structure of GSD files from Endress+Hauser

For the E+H transmitter with PROFIBUS interface, you receive all the data needed for configuration with one exe-file. Once unpacked, this file automatically creates the following structure:

At the top level, you have the measuring parameters available for the transmitter. Beneath this, you can find:

- "Revision x.xx" folder
This ID stands for the special device version. Device-specific bitmaps can be found in the "BMP" and "DIB" subdirectories.
- "GSD" folder
- "Info" folder:
Information relating to the transmitter and any dependencies in the device software.

 Please read the information in the "Info" folder carefully before configuring.

Working with the GSD / type files

The GSD files must be copied to a specific subdirectory of the PROFIBUS DP configuration software of your PLC.

Example:

Siemens S7-300/400 PLC with configuration software Siemens STEP 7

- Copy the GSD files to the subdirectory:
...\\siemens\\step7\\s7data\\gsd
- The bitmap files also belong to the GSDs. These bitmap files are used to display the measuring points in image form. Load the bitmap files to the directory:
...\\siemens\\step7\\s7data\\nsbmp

If you are using configuration software other than that referred to above, ask your PLC manufacturer which directory you should use.

7 Diagnostics and troubleshooting

System error messages

The DIAGNOSIS and DIAGNOSIS_EXTENSION parameters are generated from the device-specific errors.

Smartec S PROFIBUS diagnosis

NAMUR class	Error no.	Description	DIAGNOSIS	DIAGNOSIS_EXTENSION	Measured value status		
					Quality	Sub-Status	Hex*
Failure	E001	Memory error	01 00 00 80 - DIA_HW_ELECTR	01 00 00 00 00 00	BAD	device failure	0C
Failure	E002	Data error in EEPROM	10 00 00 80 - DIA_MEM_CHKSUM	02 00 00 00 00 00	BAD	device failure	0C
Failure	E003	Invalid configuration	00 04 00 80 - DIA_CONF_INVALID	04 00 00 00 00 00	BAD	device failure	0C
Failure	E007	Transmitter faulty	20 00 00 80 - DIA_MEASUREMENT	08 00 00 00 00 00	BAD	device failure	0C
Failure	E008	Sensor or sensor connection faulty	20 00 00 80 - DIA_MEASUREMENT	10 00 00 00 00 00	BAD	sensor failure	10
Failure	E010	Temperature sensor defective	20 00 00 80 - DIA_MEASUREMENT	20 00 00 00 00 00	BAD	sensor failure	10
Failure	E025	Limit value for airset offset exceeded	20 00 00 80 - DIA_MEASUREMENT	40 00 00 00 00 00	BAD	configuration error	04
Failure	E036	Sensor calibration range exceeded	20 00 00 80 - DIA_MEASUREMENT	80 00 00 00 00 00	BAD	configuration error	04
Failure	E037	Sensor calibration range undershot	20 00 00 80 - DIA_MEASUREMENT	00 01 00 00 00 00	BAD	configuration error	04
Failure	E045	Calibration aborted	20 00 00 80 - DIA_MEASUREMENT	00 02 00 00 00 00	BAD	configuration error	04
Failure	E049	Installation factor exceeded	20 00 00 80 - DIA_MEASUREMENT	00 04 00 00 00 00	BAD	configuration error	04
Failure	E050	Installation factor undershot	00 20 00 80 - DIA_MAINTENANCE	00 08 00 00 00 00	BAD	configuration error	5C
Failure	E055	Measuring range of the main parameter undershot	20 00 00 80 - DIA_MEASUREMENT	00 10 00 00 00 00	UNCERTAIN	sensor conversion not accurate	50
Failure	E057	Measuring range of the main parameter exceeded	20 00 00 80 - DIA_MEASUREMENT	00 20 00 00 00 00	UNCERTAIN	sensor conversion not accurate	50
Failure	E059	Temperature range undershot	20 00 00 80 - DIA_MEASUREMENT	00 40 00 00 00 00	UNCERTAIN	sensor conversion not accurate	50
Failure	E061	Temperature range exceeded	20 00 00 80 - DIA_MEASUREMENT	00 80 00 00 00 00	UNCERTAIN	sensor conversion not accurate	50
Failure	E067	Limit contactor setpoint exceeded	00 20 00 80 - DIA_MAINTENANCE	00 00 00 04 00 00	UNCERTAIN	non-specific	40
Failure	E077	Temperature outside of the α value table	00 04 00 80 - DIA_CONF_INVALID	00 00 01 00 00 00	BAD	configuration error	04
Failure	E078	Temperature outside of the concentration table	00 04 00 80 - DIA_CONF_INVALID	00 00 02 00 00 00	BAD	configuration error	04
Failure	E079	Conductivity outside of the concentration table	0 04 00 80 - DIA_CONF_INVALID	00 00 04 00 00 00	BAD	configuration error	04
Funct. check	E101	Service function active			-	-	

NAMUR class	Error no.	Description	DIAGNOSIS	DIAGNOSIS_EXTENSION	Measured value status		
					Quality	Sub-Status	Hex*
Funct. check	E102	Manual operation active			-	-	
Funct. check	E106	Download active	00 00 00 80 - EXTENSION_AVAILABLE	00 00 00 00 80	-	-	
Failure	E116	Download error	00 04 00 80 - DIA_CONF_INVALID	00 00 08 00 00 00	BAD	configuration error	04
Maint.	E150	Distance of the temperature values or α value table too low	00 20 00 80 - DIA_MAINTENANCE	00 00 00 01 00 00	UNCERTAIN	configuration error	5C
Failure	E152	Live-Check alarm (PCS)	20 00 00 80 - DIA_MEASUREMENT	00 00 00 02 00 00	BAD	sensor failure	10

* Depending on the limit bits you have to add from 00 up to 03

8 Accessories

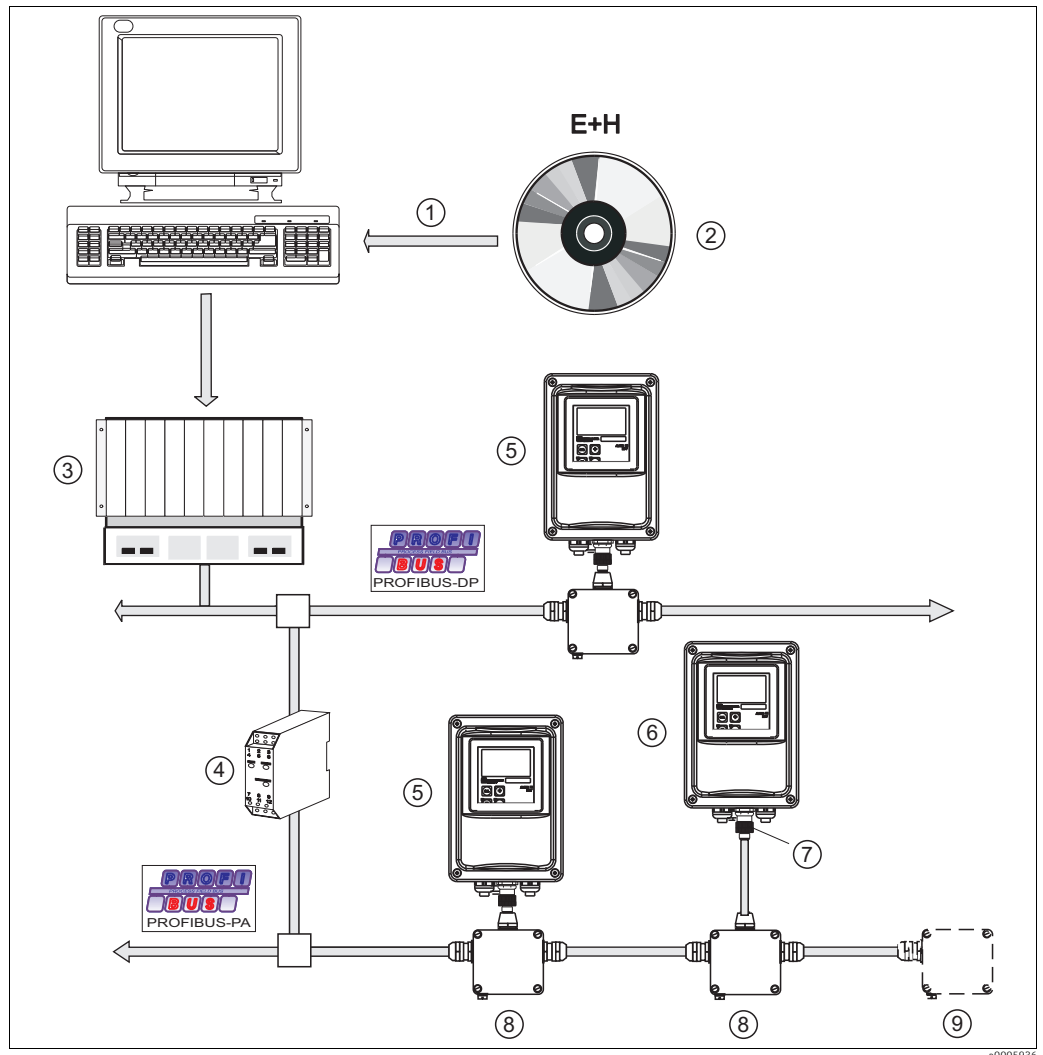

Fig. 15: Instrumentation overview Smartec S PROFIBUS

- | | | | |
|---|---------------------------|---|-----------------------------|
| 1 | PLC configuration tools | 6 | Smartec S separate mounting |
| 2 | GSD | 7 | M12 plug |
| 3 | PLC | 8 | Fieldbus connection box |
| 4 | Segment coupler | 9 | Bus termination box |
| 5 | Smartec S direct mounting | | |

- Four-pole metal plug for mounting to the transmitter
For connection to the connection box or to a cable socket. Cable length 150 mm (5.90").
order no. 51502184

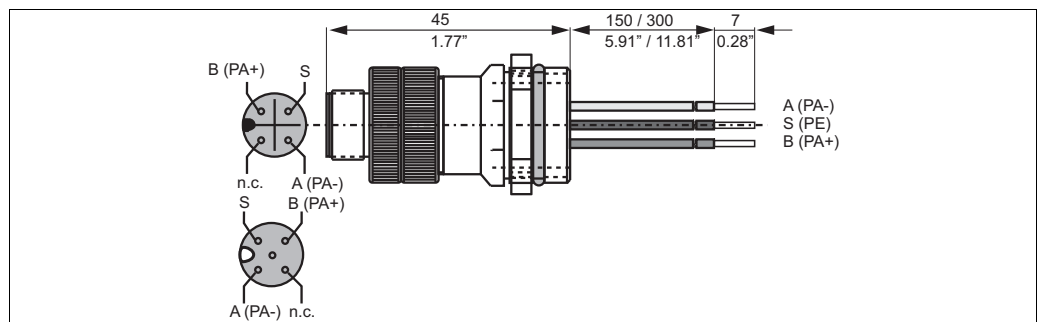

Fig. 16: M-12 plug with socket

- PROFIBUS connection box
 - For direct mounting to the transmitter.
 - Aluminum housing, IP 67, with four-pole plug connector and bus termination, two cable threads Pg 9.
 - order no. 017 481-0130
- PROFIBUS connection box with grounding capacitor
 - as above, additional internal grounding capacitor.
 - order no. 017 481-0110

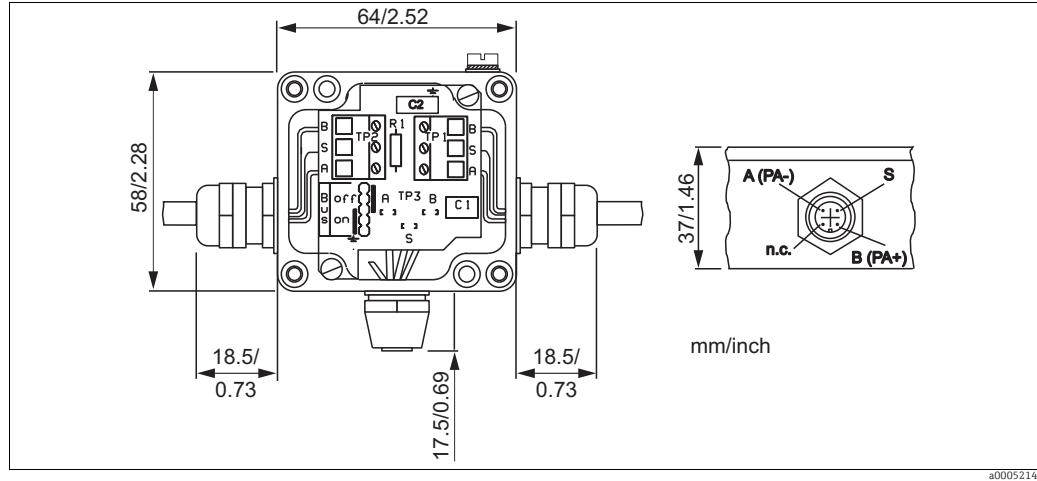

Fig. 17: Fieldbus connection box for PA

- Metal Y-adapter with two cable glands Pg 13.5.
 - order no. 51502183
- Ready-made cable with M12 plug and M12 coupling of hard PU and nickel-plated brass threads. IP 67, screen connected to the thread, PVC sheath, twisted and screened conductor pair 2/18 AWG, temperature range -40 to $+70$ °C (-40 to $+178$ °F).
 - Cable length 1 m (3.28 ft), order no. 52001025
 - Cable length 2 m (6.56 ft), order no. 52001040
 - Cable length 5 m (16.41 ft), order no. 52001041
 - Cable length 10 m (32.81 ft), order no. 52001042
- FieldCare
 - Tool for Plant Asset Management
 - Supports Ethernet, HART, PROFIBUS, FOUNDATION Fieldbus
 - FieldCare Standard, order no. SFE551-xxxx
 - FieldCare Professional, order no. SFE552-xxxx

9 Technical data

9.1 Output PROFIBUS-PA

Output signal	PROFIBUS PA acc. to EN 50170 vol. 2, profile version 3.0
PA function	Slave
Transmission rate	31.25 kbps
Signal coding	Manchester II
Response time slave	Approx. 20 ms
Signal on alarm	Status and alarm messages in accordance with PROFIBUS PA, profile version 3.0 Display: error code
Physical layer	IEC 61158-2, MBP (Manchester bus coded)
Bus voltage	9 to 32 V
Bus error consumption	10 mA \pm 1 mA
Error current consumption I_{FDE}	0 mA

9.2 Output PROFIBUS-DP

Output signal	PROFIBUS DP acc. to EN 50170 vol. 2, profile version 3.0
DP function	Slave
Transmission rate	9.6 kbps, 19.2 kbps, 45.45 kbps, 93.75 kbps, 187.5 kbps, 500 kbps, 1.5 Mbps
Signal coding	NRZ code
Response time slave	Approx. 20 ms
Signal on alarm	Status and alarm messages in accordance with PROFIBUS DP, profile version 3.0 Display: error code
Physical layer	RS 485

9.3 Display and user interface

Local operation	Via keyboard
PC operation	Via PROFIBUS with FieldCare
Bus address	Set via DIL switch or via operating menu or via Set_Slave_Adr service
Communication interface	PROFIBUS PA/DP

9.4 Standards and guidelines

PROFIBUS	EN 50170, vol. 2
PROFIBUS DP	EN 50170, vol. 2 RS 485 PNO guidelines for PROFIBUS DP
PROFIBUS PA	EN 50170, vol. 2 RS 485 PNO guidelines for PROFIBUS PA

Index

A

Acyclical data exchange	22
Address	30

B

Block model	12
-------------------	----

C

Communication	12
Customizing the cyclic data telegram	20
Cyclic data telegram	20
Cyclical data exchange	18

D

Data exchange	
Acyclical	22
Cyclical	18
Designated use	4
Device address	30
Device data file	32
Diagnostics	35
Display	11

E

Electrical connection	8
Electromagnetic compatibility	4

F

FieldCare	11
Floating-point number	19
Function check	30

I

IEEE floating-point number	19
Input-Daten	18

O

Operation	11
FieldCare	11
Operational safety	4
Output	
DP	39
PA	39

P

Post connection check	10
Post-installation check	7
Product safety	5

R

Requirements for the personnel	4
--------------------------------------	---

S

Safety instructions	4
Set device address	30
Slot/index tables	23
Standards and guidelines	40
Statuscodes	20
System equipment	6
System error messages	35
System integration	12

T

Troubleshooting	35
Type files	32

W

Workplace safety	4
------------------------	---



71228814

www.addresses.endress.com
