

Kara II

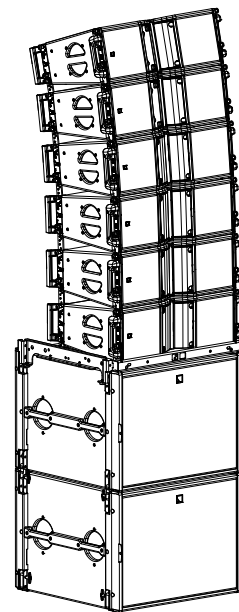

owner's manual (EN)

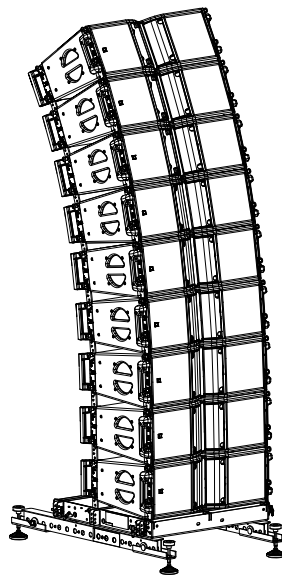
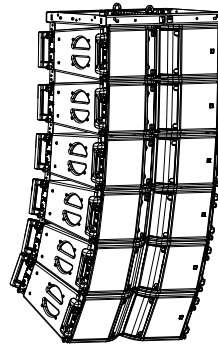
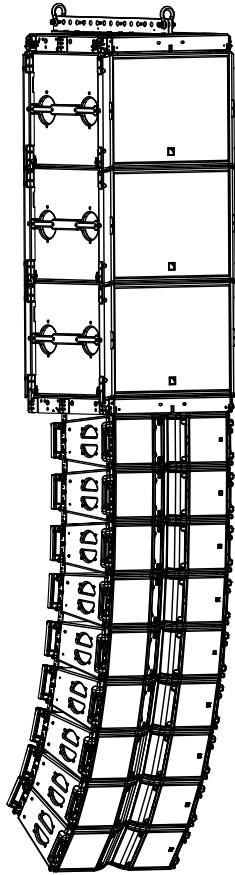

Document reference: Kara II owner's manual (EN) version 3.1

Distribution date: December 2, 2021

© 2021 L-Acoustics. All rights reserved.

No part of this publication may be reproduced or transmitted in any form or by any means without the express written consent of the publisher.

Contents

Safety.....	6
Instructions.....	6
Introduction.....	8
Kara II long throw line source.....	8
How to use this manual.....	8
Revision history.....	9
System components.....	10
Electro-acoustical description.....	13
Adjustable fins.....	13
Directivity.....	16
Preset description.....	18
Connectors.....	19
Rigging system description.....	20
Kara II.....	20
SB18.....	22
Rigging elements.....	23
M-BUMP.....	23
KARA-MINIBU.....	24
M-BAR.....	25
M-JACK, KARA-ANGARMEX.....	26
KARA-MINIBUEX, KARA-ANGARMEX.....	28
KARA-PULLBACK.....	29
Transportation.....	30
Flight-case.....	30
Mechanical safety.....	31
Loudspeaker configurations.....	33
Line source.....	33
Line source with low-frequency element.....	34
Line source element.....	38
Inspection and preventive maintenance.....	39
How to do preventive maintenance.....	39
Rigging part inspection.....	39
Mechanical system overview.....	40
Mixed Kara II array with SB18 and M-BUMP.....	41

Mixed Kara II array with SB18, KARA-MINIBU/KARA-MINIBUEX and KARA-PULLBACK.....	42
Stacked Kara II array with M-BUMP, M-JACK and KARA-ANGARMEX.....	43
Rigging check.....	44
Inspection references.....	47
Acoustical check.....	50
Rigging procedures.....	54
Flying a Kara II standalone array.....	54
Using M-BUMP.....	54
Using KARA-MINIBU.....	65
Flying an SB18/Kara II mixed array or an SB18 standalone array.....	74
Using M-BUMP.....	74
Using KARA-MINIBU.....	85
Stacking a Kara II standalone array.....	96
Using M-BUMP.....	96
Using KARA-MINIBU.....	109
Stacking an SB18/Kara II mixed array or an SB18 standalone array.....	121
Using M-BUMP.....	121
Using KARA-MINIBU.....	131
Connection to LA amplified controllers.....	145
Cabling schemes.....	145
Corrective maintenance.....	147
Introduction.....	147
Kara II.....	149
SB18.....	158
M-BUMP.....	168
M-BAR.....	172
KARA-MINIBU.....	174
KARA-MINIBUEX.....	176
Specifications.....	179
APPENDIX A: Installing an inclinometer.....	192
APPENDIX B: Flown array options and site angle setting.....	194
Using M-BUMP.....	194
Using KARA-MINIBU.....	197
APPENDIX C: Stacked array options and site angle setting.....	200
Using M-BUMP.....	200
Using KARA-MINIBU.....	202

Safety

Instructions



Inspect the system before any deployment.

Perform safety related checks and inspections before any deployment.

Perform preventive maintenance at least once a year.

Refer to the preventive maintenance section for a list of actions and their periodicity.

Insufficient upkeep of the product can void the warranty.

If any safety issue is detected during inspection, do not use the product before performing corrective maintenance.

Check for issues. A rigging system part or fastener is missing or loose. A rigging system part exhibits: bends, breaks, broken parts, corrosion, cracks, cracks in welded joints, deformation, denting, wear, holes. A safety cue or label is missing.



Never incorporate equipment or accessories not approved by L-Acoustics.

Read all the related PRODUCT INFORMATION documents shipped with the products before exploiting the system.



Do not store the product on an unstable cart, stand, tripod, bracket, or table.



Beware of sound levels.

Do not stay within close proximity of loudspeakers in operation.

Loudspeaker systems are capable of producing very high sound pressure levels (SPL) which can instantaneously lead to permanent hearing damage to performers, production crew and audience members. Hearing damage can also occur at moderate level with prolonged exposure to sound.

Check the applicable laws and regulations relating to maximum sound levels and exposure times.



Work with qualified personnel for rigging the system

Installation should only be carried out by qualified personnel that are familiar with the rigging techniques and safety recommendations outlined in this manual.

Ensure personnel health and safety

During installation and set-up personnel must wear protective headgear and footwear at all times. Under no circumstances is personnel allowed to climb on a loudspeaker assembly.

Respect the Working Load Limit (WLL) of third party equipment.

L-Acoustics is not responsible for any rigging equipment and accessories provided by third party manufacturers.

Verify that the Working Load Limit (WLL) of the suspension points, chain hoists and all additional hardware rigging accessories is respected.

Respect the maximum configurations and the recommended safety precautions.

For safety issue, respect the maximum configurations outlined in this manual. To check the conformity of any configuration in regards with the safety precautions recommended by L-Acoustics, model the system in Soundvision and refer to the warnings in Mechanical Data section.

Be cautious when flying a loudspeaker configuration.

Before installing/raising the product, check each individual element to make sure that it is securely fastened to the adjacent element. Always verify that no one is standing underneath the product when it is being installed/raised. Never leave the product unattended during the installation process.

As a general rule, L-Acoustics recommends the use of secondary safety at all times.

Be cautious when ground-stacking a loudspeaker array.

Do not stack the loudspeaker array on unstable ground or surface. If the array is stacked on a structure, platform, or stage, always check that the latter can support the total weight of the array.

As a general rule, L-Acoustics recommends the use of safety straps at all times.

Risk of falling objects

Verify that no unattached items remain on the product or assembly.

Risk of tipping

Remove all rigging accessories before transporting a product or an assembly.

Take into account the wind effects on dynamic load.

When a loudspeaker assembly is deployed in an open air environment, wind can produce dynamic stress to the rigging components and suspension points.

If the wind force exceeds 6 bft (Beaufort scale), lower down and/or secure the product or the assembly.

**Intended use**

This system is intended for use by trained personnel for professional applications.



As part of a continuous evolution of techniques and standards, L-Acoustics reserves the right to change the specifications of its products and the content of its documents without prior notice.

Check www.l-acoustics.com on a regular basis to download the latest document and software updates.

**Long term exposure to extreme conditions may damage the product.**

For more information, refer to the **Products weather protection** document, available on the website.

**Read the maintenance section of this document before servicing the product.****Contact L-Acoustics for advanced maintenance.**

Any unauthorized maintenance operation will void the product warranty.



This marking indicates that this product should not be disposed of with other household waste throughout the EU. To prevent possible harm to the environment or human health from uncontrolled waste disposal, recycle it responsibly to promote the sustainable reuse of material resources. To return your used device, please use the return and collection systems or contact the retailer where the product was purchased. They can take this product for environmentally safe recycling.



Introduction

Kara II long throw line source

Part of the K Series, Kara II is a modular line source system that can be deployed standalone or with its companion subwoofer SB18. Assembled as a variable curvature line source with class-leading SPL per weight and footprint, Kara II is ideal for applications that require clarity and long throw capability such as performing arts, congregations, large corporate, or special events.

Based on the Kara design, Kara II adds flexibility with Panflex™. A single Kara II enclosure offers four horizontal directivity patterns: 70° or 110° symmetrical and 90° asymmetrical on either side. With a tighter control of the directivity, the 70° setting brings an additional 2 dB compared to the 110° setting increasing throw capability. With Panflex and inter-element angles ranging from 0° to 10°, a Kara II line source coverage can be precisely tailored to any audience geometry.

On its own Kara II can be used as a main system for vocal reinforcement and music material with light LF requirements or as a complement to large sound systems in fill and delay applications. Associated with its companion subwoofer SB18, Kara II modular system can accommodate any program material requiring bandwidth, contour and output.

How to use this manual

The Kara II owner's manual is intended for all actors involved in the system design, implementation, preventive and corrective maintenance of the Kara II system. It must be used as follows:

1. Read the technical description for an overview of all system elements, their features, and their compatibilities.
 - [Electro-acoustical description](#) (p.13)
 - [Rigging system description](#) (p.20)
2. Prepare the system configuration. Consider the mechanical limits and the available acoustical configurations.
 - [Mechanical safety](#) (p.31)
 - [Loudspeaker configurations](#) (p.33)
3. Before rigging the system, perform mandatory inspections and functional checks.
 - [Inspection and preventive maintenance](#) (p.39)
4. To deploy the system, follow the step-by-step rigging instructions and refer to the cabling schemes.
 - [Rigging procedures](#) (p.54)
 - [Connection to LA amplified controllers](#) (p.145)



The [Corrective maintenance](#) (p.147) section contains the operations authorized for the end user. Performing another operation exposes to hazardous situations. For advanced maintenance, contact your L-Acoustics representative.

As part of a continuous evolution of techniques and standards, L-Acoustics reserves the right to change the specifications of its products and the content of its document without prior notice. Please check www.l-acoustics.com on a regular basis to download the latest document and software updates.

Contact information

For information on advanced corrective maintenance:

- contact your Certified Provider or your L-Acoustics representative
- for Certified Providers, contact the L-Acoustics customer service: customer.service@l-acoustics.com

Symbols

The following symbols are used in this document:

 This symbol indicates a potential risk of harm to an individual or damage to the product. It can also notify the user about instructions that must be strictly followed to ensure safe installation or operation of the product.

 This symbol notifies the user about instructions that must be strictly followed to ensure proper installation or operation of the product.

 This symbol notifies the user about complementary information or optional instructions.

Revision history

version number	publication date	modification
1.0	Mar. 2020	Initial version.
2.0	Apr. 2020	Added Corrective maintenance section.
2.1	Jul. 2021	<ul style="list-style-type: none"> Added instructions to select the HF driver repair kit for Kara II based on the enclosure serial number. See Kara II exploded views (p.149). Updated maximum drive capacity for SB18 on LA8.
2.2	Sept. 2021	Minor fixes and improvements.
3.0	Oct. 2021	Changed maximum limit for pullback configuration following the release of Soundvision 3.6.0. See Mechanical safety (p.31).
3.1	Dec. 2021	Updated LF speaker disassembly instructions for Kara II. See LF speaker (p.153).

System components

Loudspeaker enclosures

Kara II	2-way active WST® enclosure: 2 x 8" LF + 3" HF diaphragm
SB18	High power compact subwoofer: 1 x 18"
SB28	High power subwoofer: 2 x 18"
KS28	Flyable subwoofer 2 x 18"
KS21	High power compact subwoofer: 1x21"

Powering and driving system

LA4X / LA8 / LA12X Amplified controller with DSP, preset library and networking capabilities



Refer to the LA4X / LA8 / LA12X owner's manual for operating instructions.

Racks

LA-RAK	Touring rack containing three LA8 and power, audio and network distribution
LA-RAK II AVB	Touring rack containing three LA12X, LA-POWER II for power distribution, LA-PANEL II for audio and network distribution, and two LS10 for AVB distribution

Cables

SP cables	SpeakON loudspeaker cables (4-point, 4 mm ² gauge) Come in different sizes: SP.7 (0.7 m/2.3 ft), SP5 (5 m/16.4 ft), SP10 (10 m/32.8 ft), and SP25 (25 m/82 ft)
SP-Y1	Breakout cable for two passive enclosures (2.5 mm ² gauge) 4-point speakON to 2 x 2-point speakON, provided with a CC4FP adapter
DO cables	PA-COM loudspeaker cables (8-point, 4 mm ² gauge) Come in different sizes: DO.7 (0.7 m/2.3 ft), DO.10 (10 m/32.8 ft), and DO.25 (25 m/82 ft)
DOSUB-LA8	Breakout cable for four passive enclosures (4 mm ² gauge) 8-point PA-COM to 4 x 2-point speakON
DOFILL-LA8	Breakout cable for two 2-way active enclosures (4 mm ² gauge) 8-point PA-COM to 2 x 4-point speakON
DO3WFILL	Breakout cable for one 2-way active enclosure and two passive enclosures (4 mm ² gauge) 8-point PA-COM to 1 x 4-point speakON and 2 x 2-point speakON



Information about the connection of the enclosures to the LA amplified controllers is given in this document.

Refer to the LA4X / LA8 / LA12X owner's manual for detailed instructions about the whole cabling scheme, including modulation cables and network.

Rigging elements

M-BUMP	Bumper for flying or stacking KARA/SB18
M-BAR	Extension bar for rigging frame
M-JACK	4 tilt adjustment screw jacks with 2 angle bar extensions for stacked M-BUMP
KARA-ANGARMEX	2 angle bar extension for KARA bumper

KARA-MINIBU	Mini bumper for flying 6 KARA
KARA-MINIBUEX	Extension bars for flying/stacking SB18/KARA
KARA-PULLBACK	pullback plate for Kara

Software applications

Soundvision	3D acoustical and mechanical modeling software
LA Network Manager	Software for remote control and monitoring of amplified controllers

i Refer to the **Soundvision** help.
i Refer to the **LA Network Manager** help.

System component illustrations

Cables

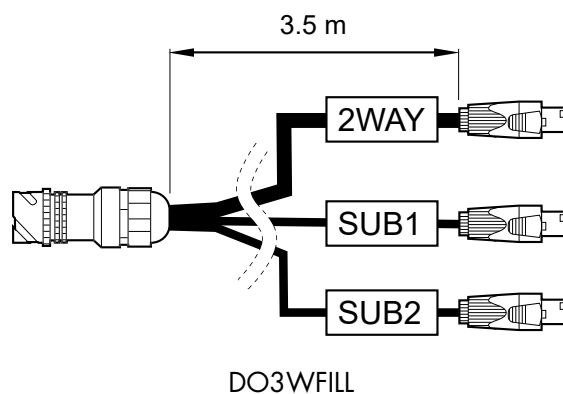
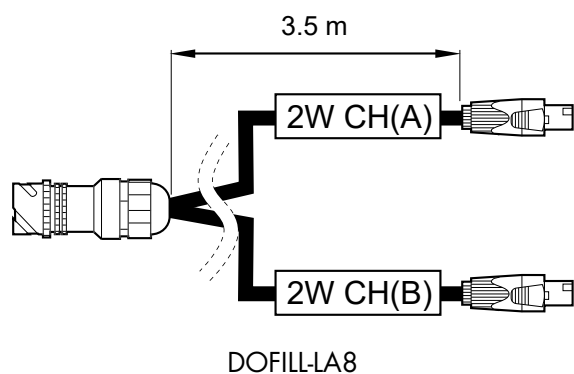
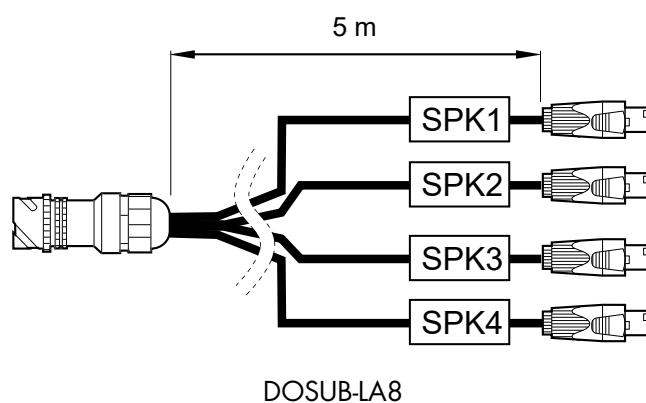
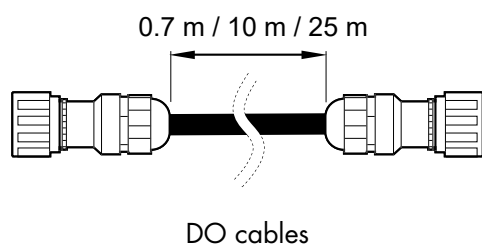
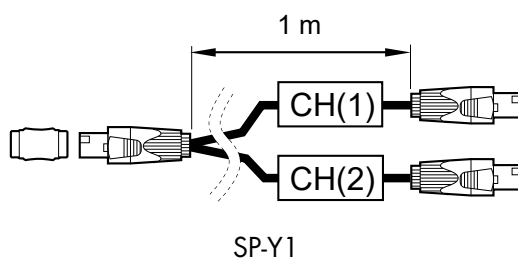
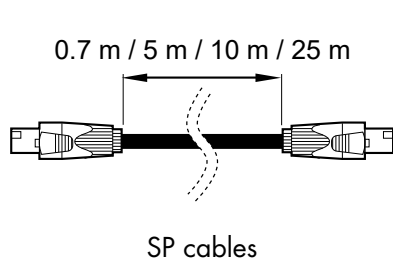

Rigging accessories

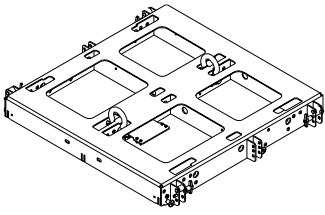

M-BUMP

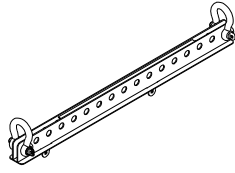

M-BAR

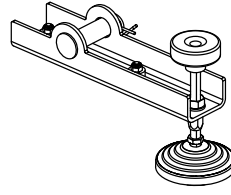

M-JACK

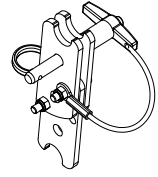

KARA-
ANGARMEX

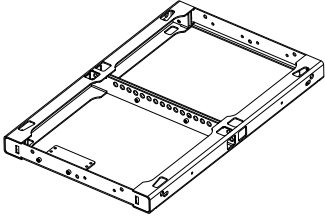

KARA-MINIBU

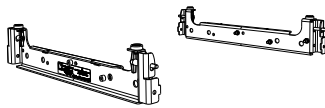

KARA-MINIBUEX

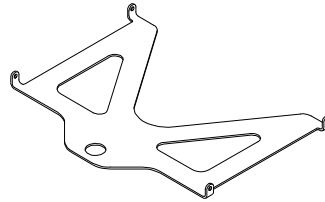

KARA-PULLBACK

Electro-acoustical description

Adjustable fins

Kara II features L-Fins to adjust the waveguide directivity to one of four settings: 110° / 70° symmetric or 90° asymmetric (35°/55° or 55°/35°).

A specific Kara II preset must be used for each directivity setting.

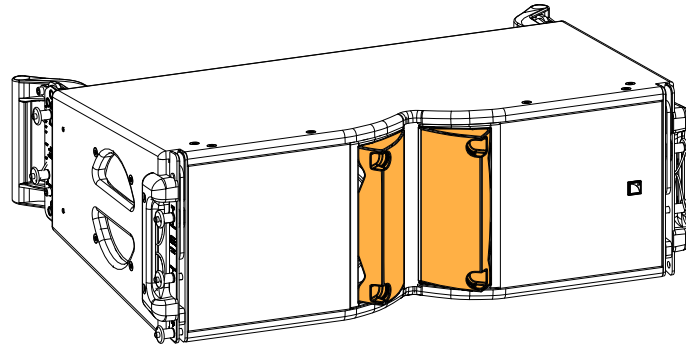

Within a line source, combine Kara II with custom directivity settings to improve SPL mapping and throw capability.

110° setting

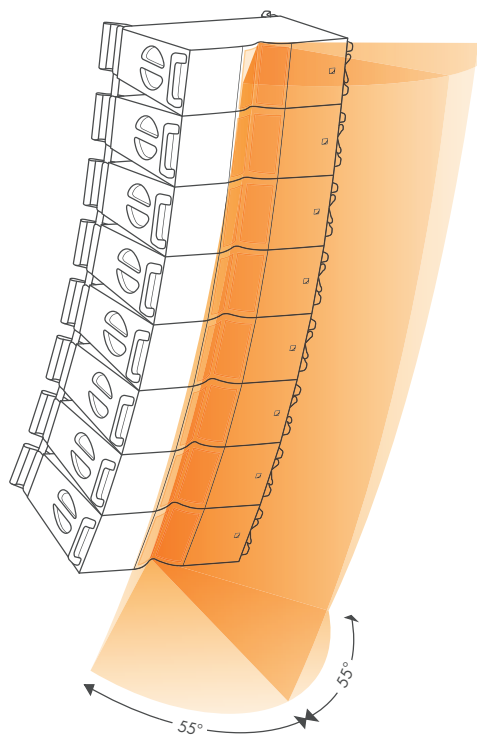
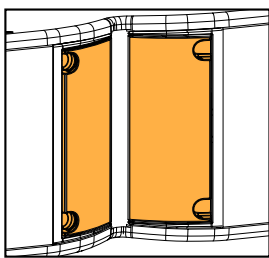

70° setting

Set the fins in the 35° position to provide the system with a 2 dB on-axis gain (> 1 kHz).

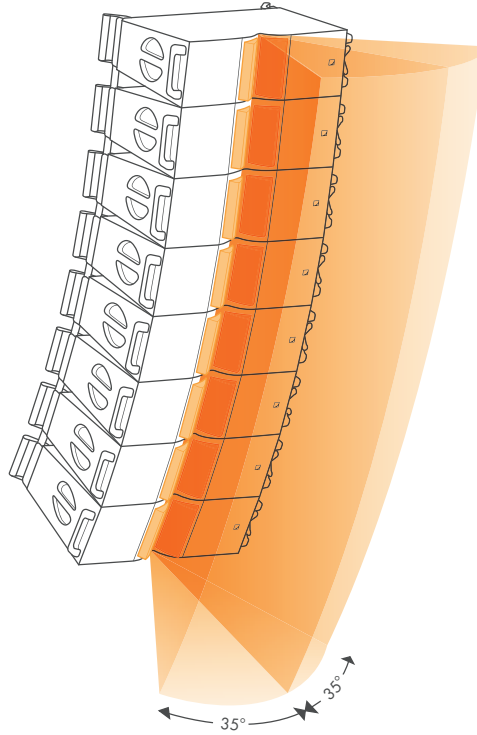
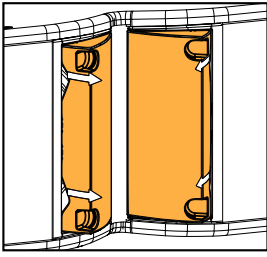

90° settings

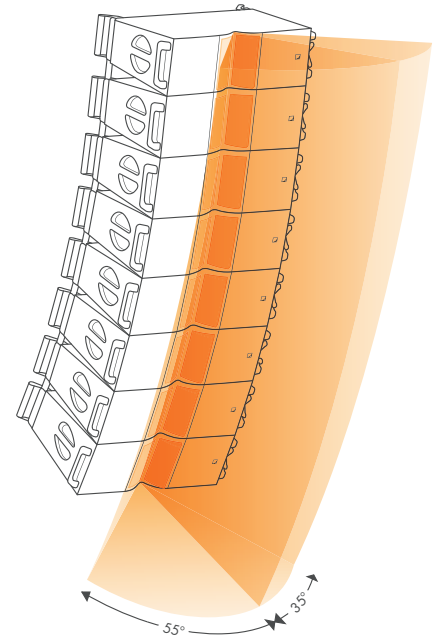
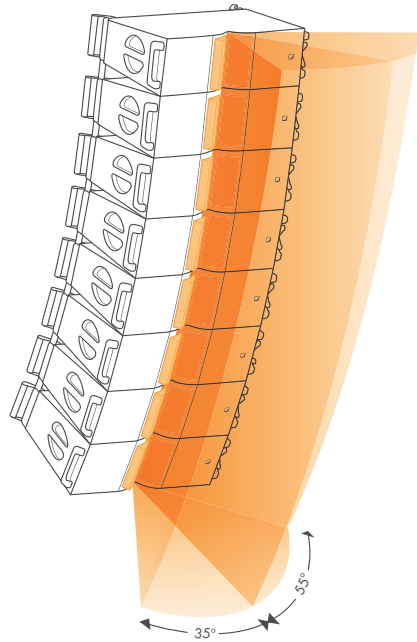
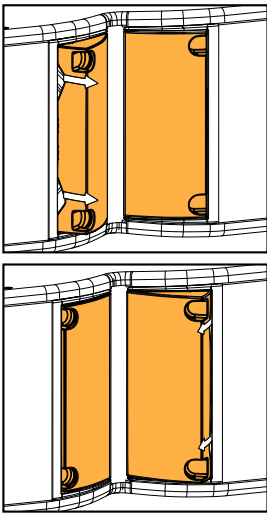

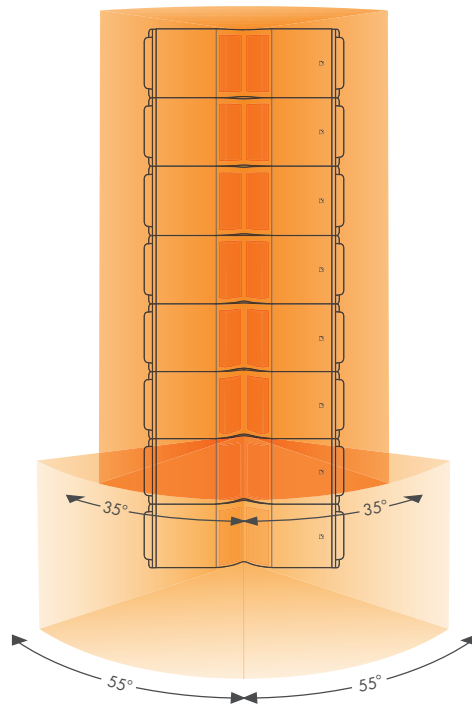
Mixed settings

Directivity

Horizontal

Dispersion angle diagrams of one Kara II in the horizontal plane for all fins settings using lines of equal sound pressure at -3 dB, -6 dB, -12 dB.

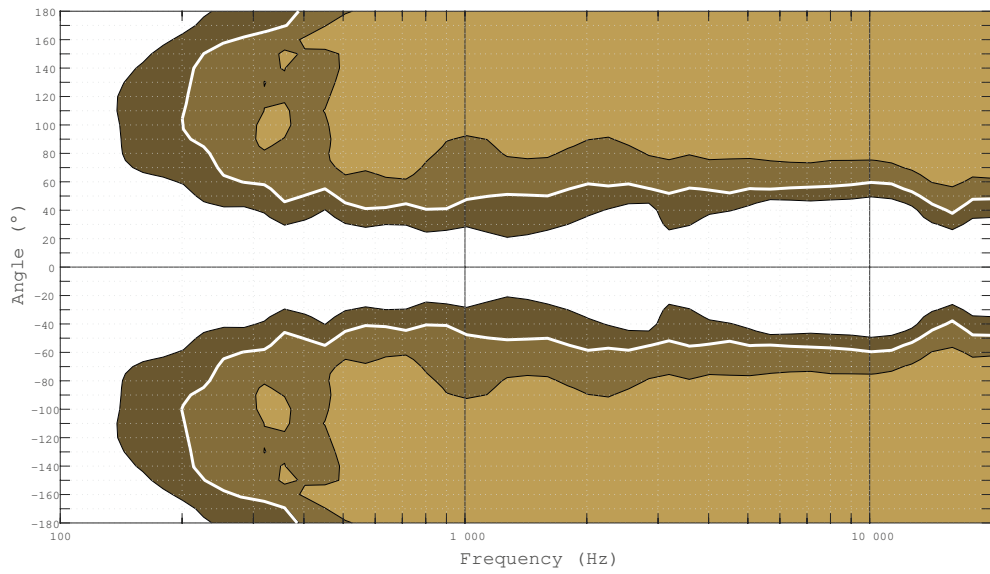
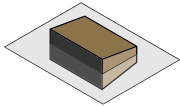

110° fins setting

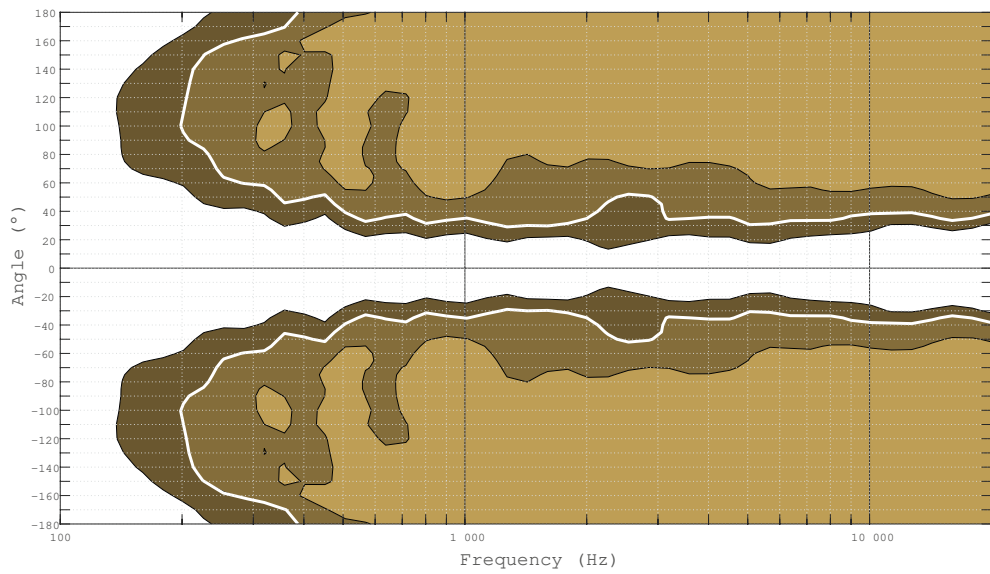
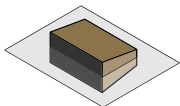

70° fins setting

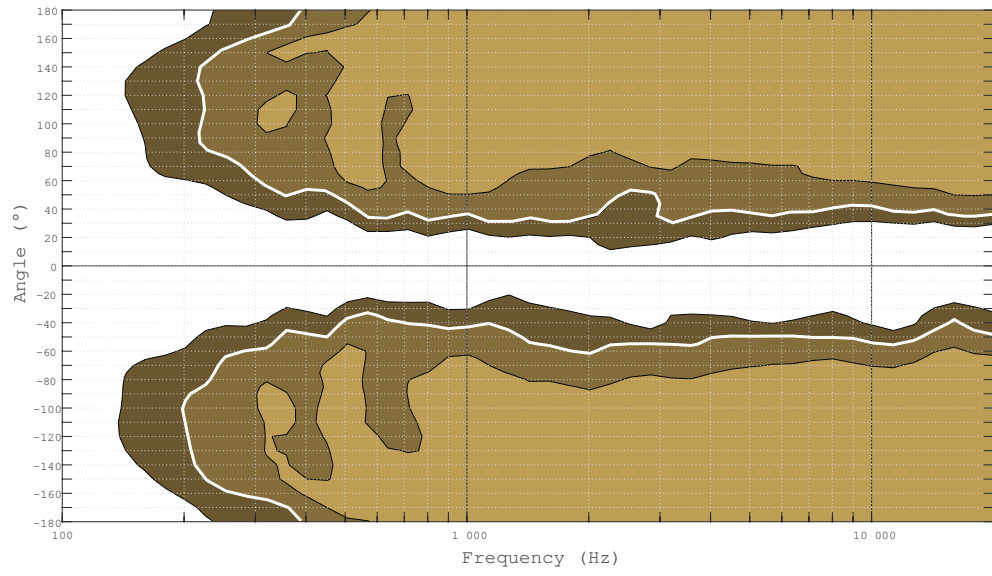
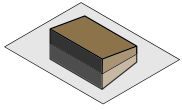

90° fins setting

Preset description

[KS28_60] [SB28_60] [KS21_60] [KS21_100] [SB18_60] [SB18_100]

outputs	channels	routing	gain	delay	polarity	mute
OUT 1	SB	IN A	0 dB	0 ms	+	ON
OUT 2	SB	IN A	0 dB	0 ms	+	ON
OUT 3	SB	IN A	0 dB	0 ms	+	ON
OUT 4	SB	IN A	0 dB	0 ms	+	ON

[KS28_60_C] [KS28_60_Cx] [SB28_60_C] [SB28_60_Cx] [KS21_60_C] [KS21_100_C] [KS21_60_Cx]
[KS21_100_Cx] [SB18_60_C] [SB18_100_C] [SB18_60_Cx] [SB18_100_Cx]

loudspeaker elements	outputs	channels	routing	gain	delay	polarity	mute
SR	OUT 1	SR	IN A	0 dB	0 ms	+	ON
SB	OUT 2	SB					ON
SB	OUT 3	SB					ON
SB	OUT 4	SB					ON

Connectors



SpeakON connectors can be used interchangeably as IN or LINK connector.

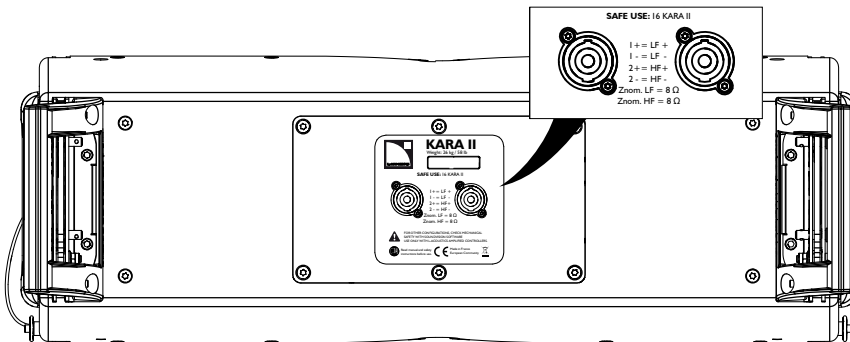

Kara II

2 × 4-point speakON

Internal pinout for L-Acoustics 2-way active enclosures

SpeakON points	1 +	1 -	2 +	2 -
Transducer connectors	LF +	LF -	HF +	HF -

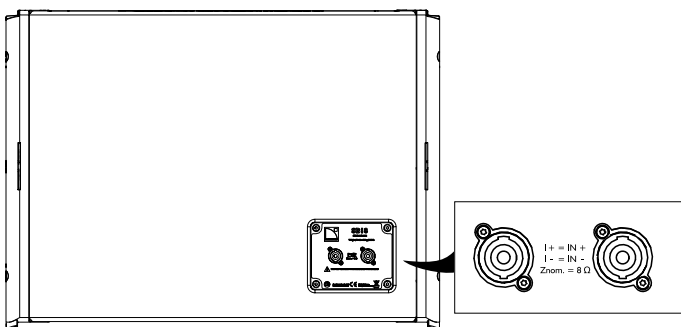

SB18

2 × 4-point speakON

Internal pinout for L-Acoustics subwoofers

SpeakON points	1 +	1 -	2 +	2 -
Transducer connectors	LF +	LF -	Not linked	Not linked

Rigging system description

Kara II

Kara II features a four-point rigging system composed of two adjustable rigging arms secured with ball-locking pins and two lodgings with ball-locking pins on both sides of the enclosure.

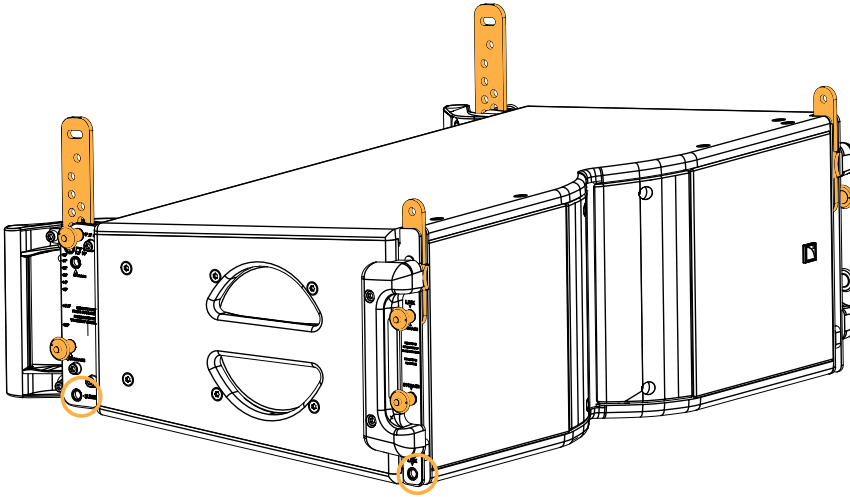

Kara II can be connected to other Kara II enclosures or to dedicated rigging accessories. The inter-enclosure angle can be set between 0° and 10°.

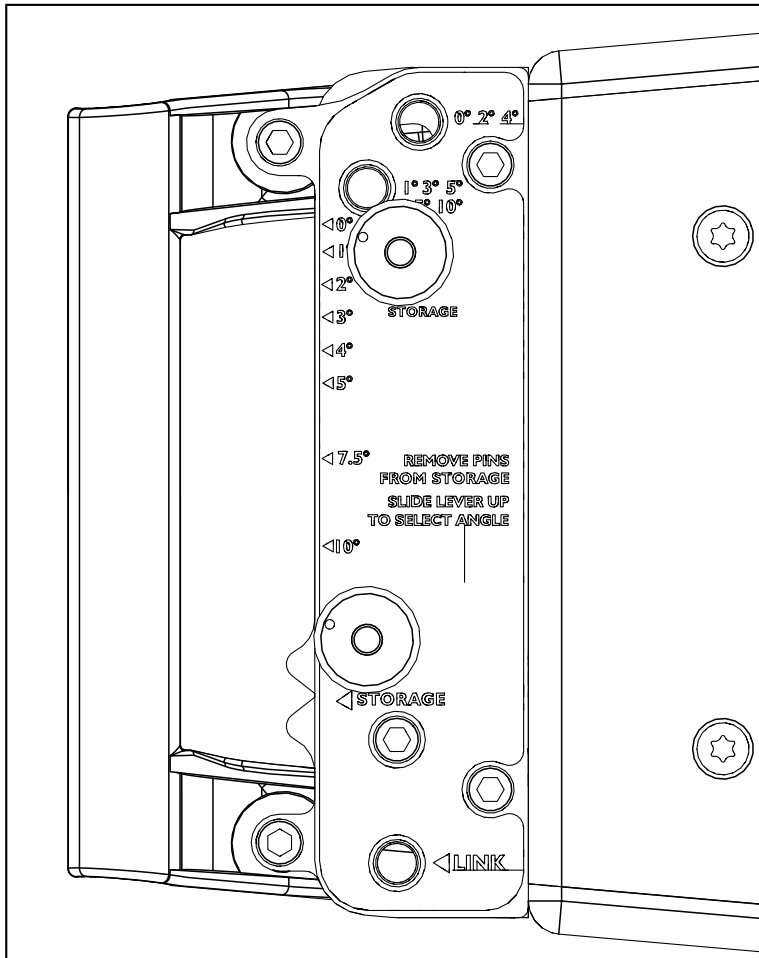

**Risk of blocked ball-locking pin.**

Be careful not to trap the ball-locking pin tether between the rigging arm and the side handle.

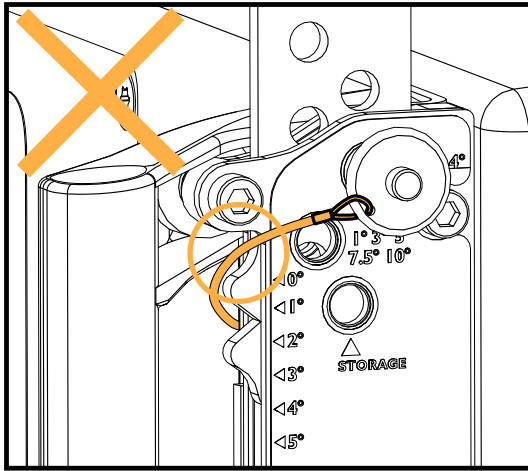

SB18

i For more information on rigging SB18, refer to the **SB18 rigging manual**.

SB18 has a four-point rigging system with two rigging arms and two pins on each side.

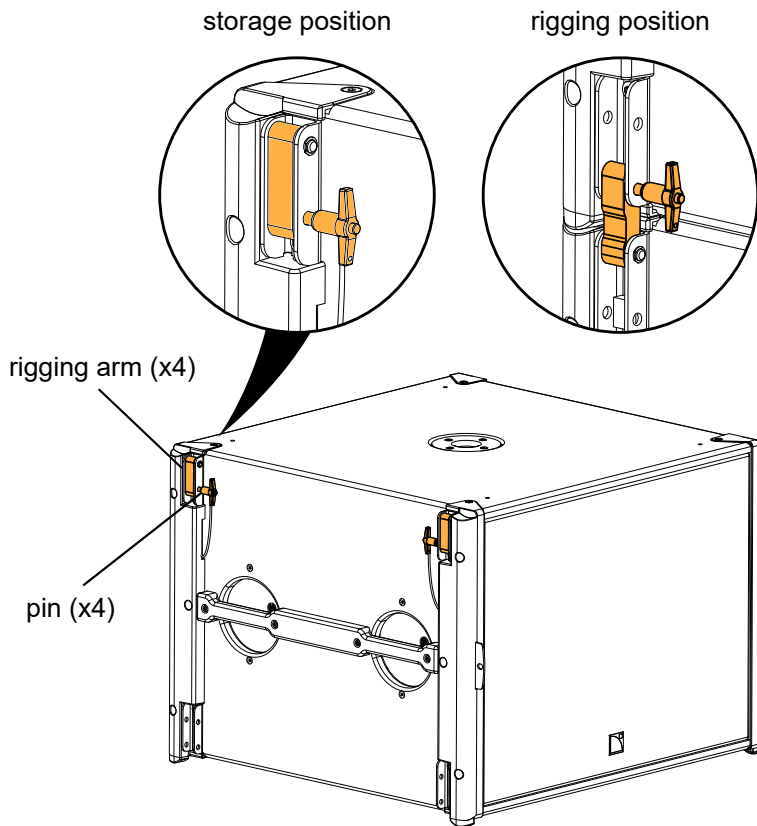

SB18 features a 35 mm pole socket.

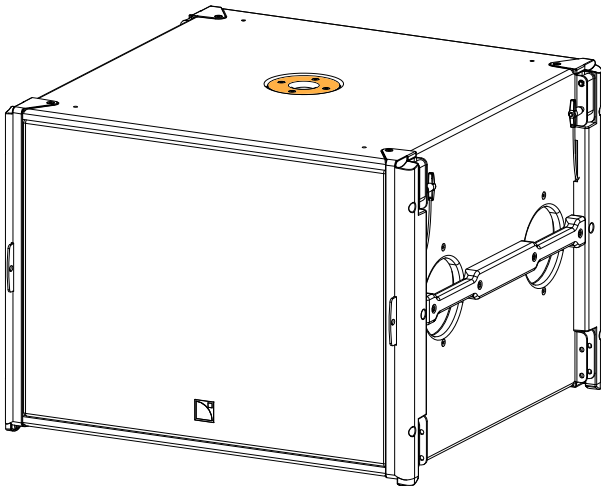

Rigging elements

M-BUMP

Rigging structure

The L-Acoustics M-BUMP rigging structure has been designed to fly or stack the Kara II enclosures as a variable-curvature, vertical line source array. M-BUMP also allows Kara II to be rigged to an SB18 subwoofer array.

i M-BUMP also can fly straight vertical SB18 arrays.

The M-BUMP is a square frame fitted with the following elements:

- Four 5/16" R-BLP (round-shaped ball-locking pins) for Kara II rigging.
- Four rotating arms with 5/16" T-BLP (T-shaped ball-locking pins) for SB18 rigging.
- One laser support plate with four bolts for optional laser/inclinometer device mounting (refer to [Installing an inclinometer](#) (p.192)).
- Two shackles fitted with 19 mm/0.75 inch-diameter axis.

i Refer to [M-BUMP rigging options](#) (p.194) for distance between shackles.

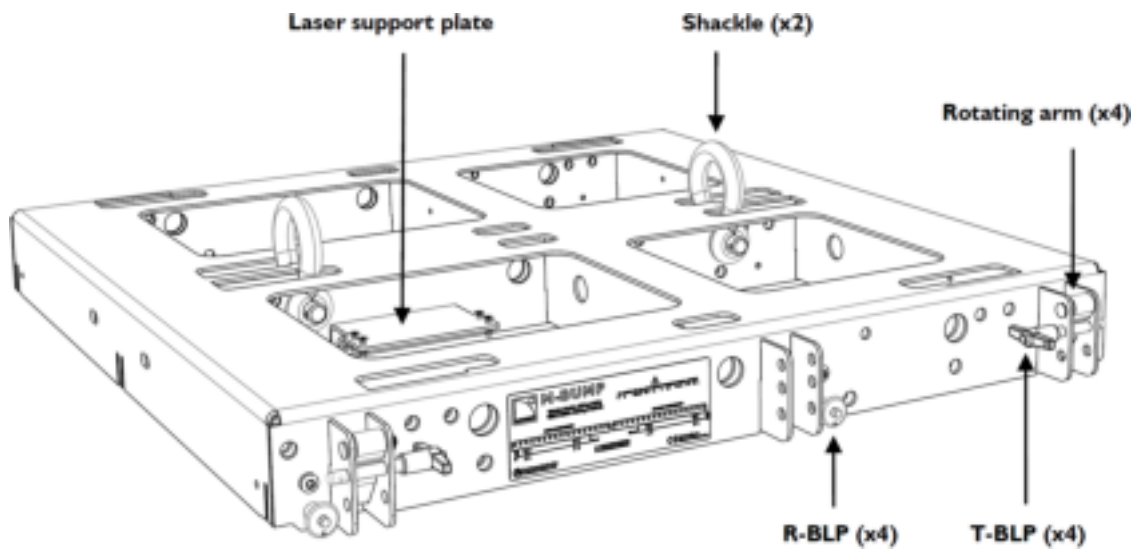

KARA-MINIBU

Rigging structure

The L-Acoustics KARA-MINIBU rigging structure has been designed to fly or stack the Kara II enclosures as a variable-curvature, vertical line source array. KARA-MINIBU also allows Kara II to be attached to an SB18 subwoofer array.

i KARA-MINIBU also can fly straight vertical SB18 arrays.

The KARA-MINIBU is a rectangular frame fitted with the following elements:

- Four 5/16" R-BLP (round-shaped ball-locking pins) for Kara II rigging.
- One laser support plate with four bolts for optional laser/inclinometer device mounting. (refer to [Installing an inclinometer](#) (p.192))
- Two shackles fitted with 12 mm/0.47 inch-diameter axis.
- 17 shackle holes for rigging.
- 2 shackle holes for pullback configurations.

i Refer to [KARA-MINIBU rigging options](#) (p.197) for distance between shackles.

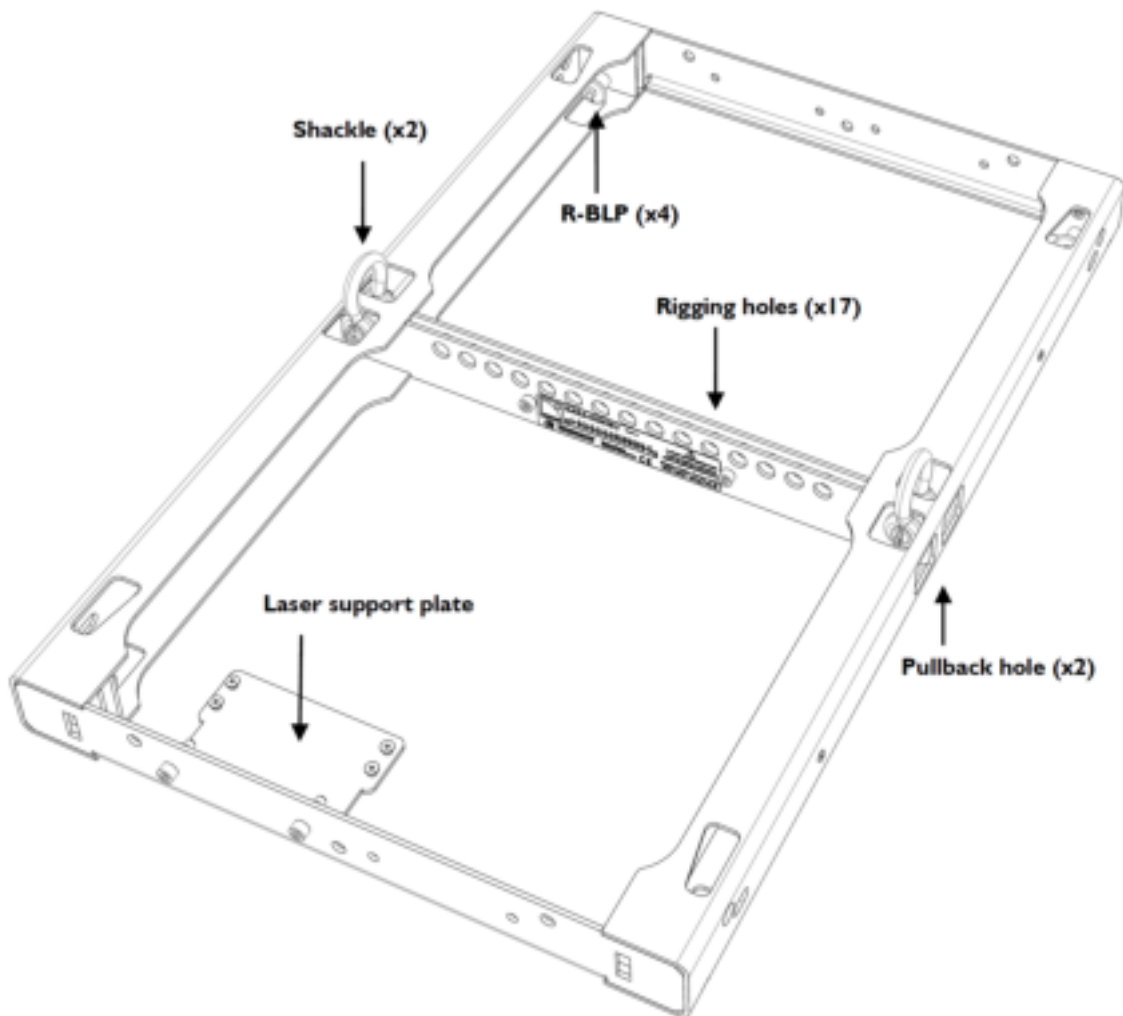

M-BAR

Extension bar

The L-Acoustics M-BAR extension bar is a complementary rigging element for M-BUMP. Optionally used as a single element or in pair in flown configurations, it will extend the site angle capability of Kara II and SB18 arrays. In stacked configurations, its use is required in pairs as part of the stacking platform (see [M-JACK](#), [KARA-ANGARMEX](#) (p.26)).

The M-BAR is a bar fitted with the following elements:

- Two 3/8" T-BLP for M-BUMP rigging.
- Two shackles fitted with 19 mm/0.75 inch-diameter axis.

i Refer to [M-BUMP rigging options](#) (p.194) for distance between shackles.

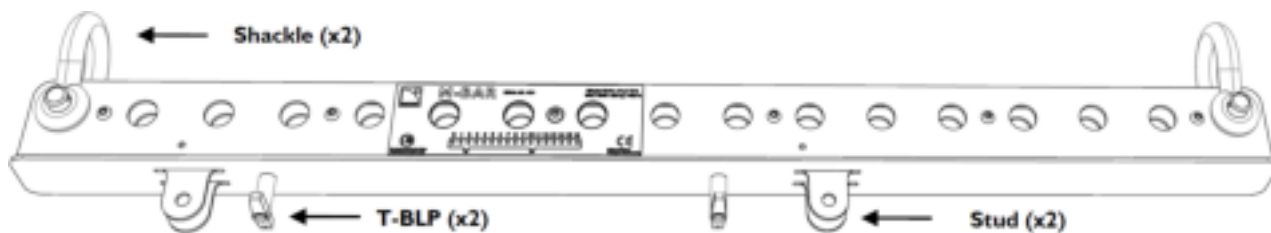

M-BAR

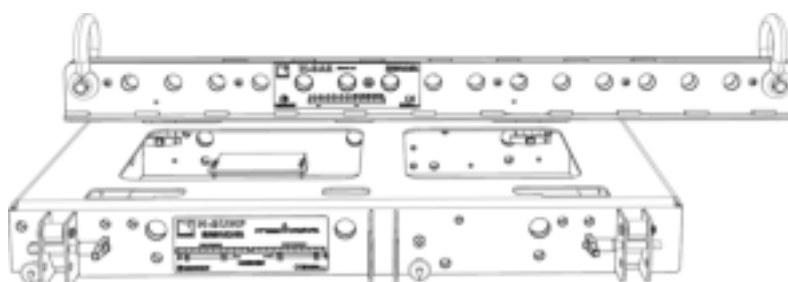

One M-BAR mounted to M-BUMP

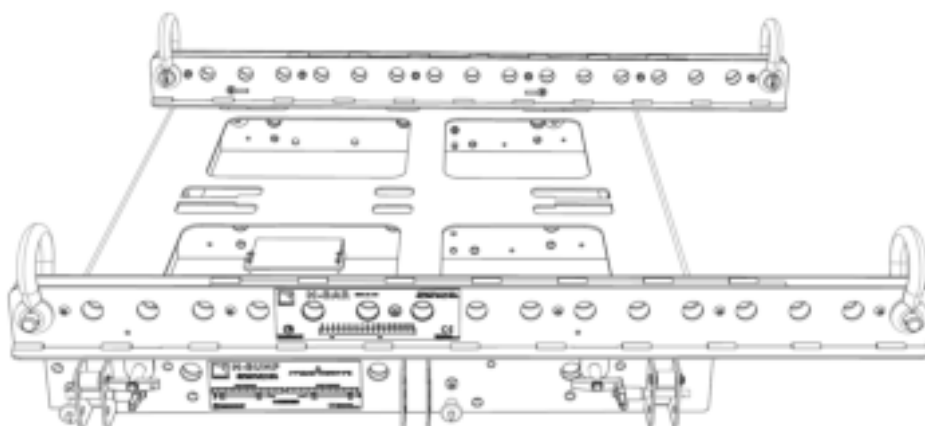

Two M-BAR mounted to M-BUMP

M-JACK, KARA-ANGARMEX

Stacking platform (with optional angle arm extensions)

The L-Acoustics M-JACK are four feet to be used along with one M-BUMP and two M-BAR so as to form a stacking platform for a variable-curvature, vertical Kara II line source array.

The L-Acoustics KARA-ANGARMEX are two angle arm extensions providing extra 10° downwards site angle for the bottom Kara II in stacked configurations.

i Two KARA-ANGARMEX are also included in the M-JACK package.

The M-JACK package comprises the following elements:

- Four feet fitted with height-adjustment and locking system.
- Four axis and safety pins for securing M-JACK on M-BAR
- Two angle arm extensions with 5/16" T-BLP.

The KARA-ANGARMEX package comprises two angle arm extensions with 5/16" T-BLP.

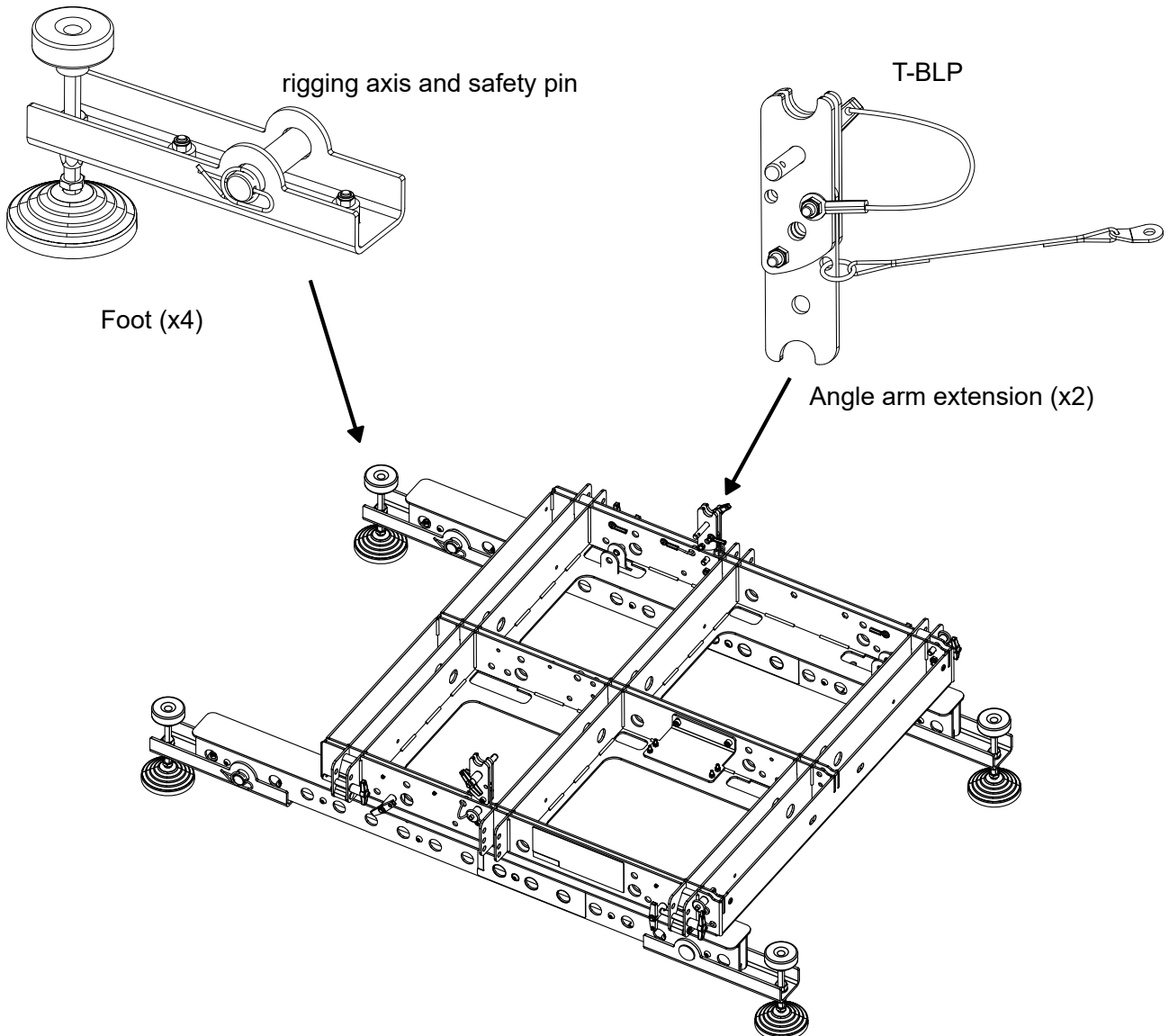

KARA-ANGARMEX attached to M-BUMP

The KARA-ANGARMEX angle arm extensions are provided with two slings and fixation material to be permanently attached to the M-BUMP. Attach the slings to the holes shown in the figure below and respect the orientation:

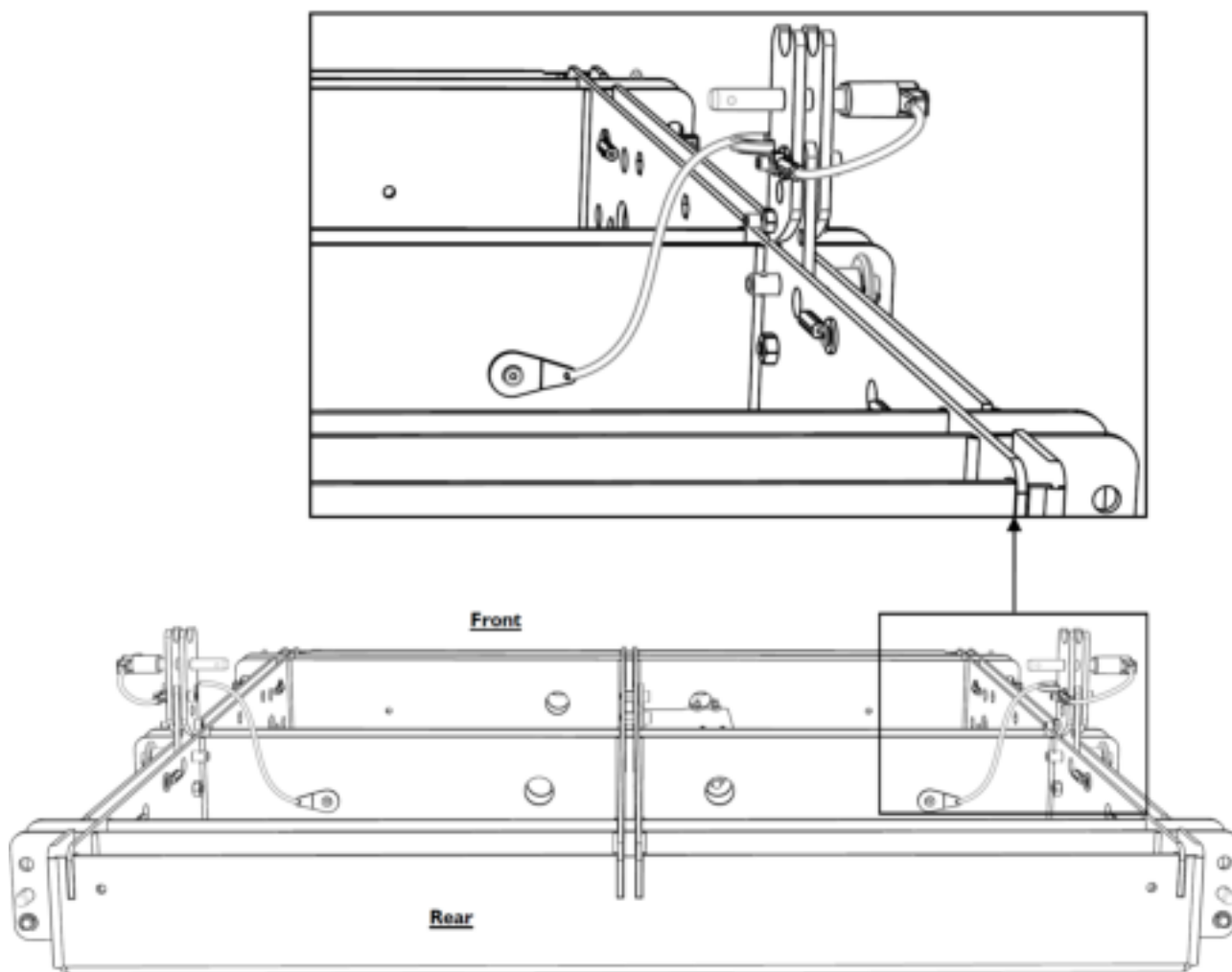

When they are not used, KARA-ANGARMEX can be secured in storage position on M-BUMP with the T-BLP.

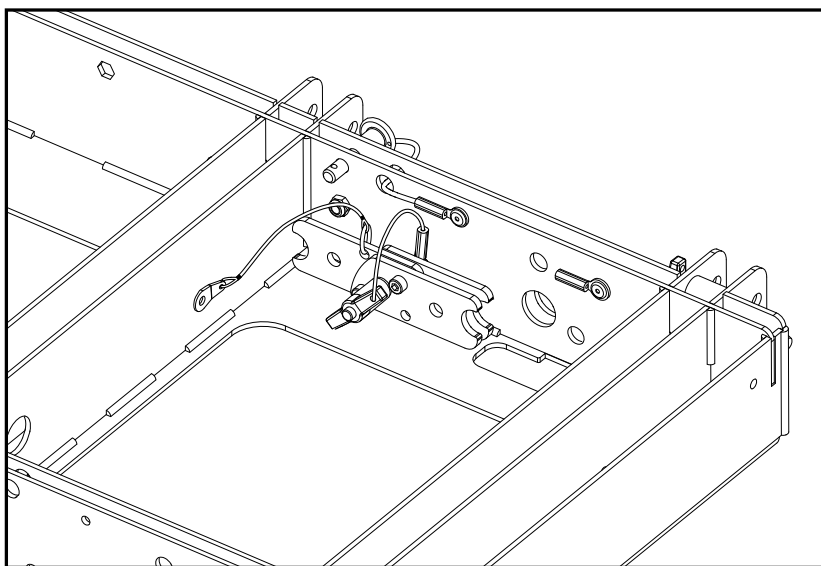

KARA-MINIBUEX, KARA-ANGARMEX

Rigging structure

The L-Acoustics KARA-MINIBUEX is a set of two complementary rigging plates for KARA-MINIBU to adapt to the SB18 enclosure or to stack Kara II.

The L-Acoustics KARA-ANGARMEX is a set of two angle arm extensions providing extra 10° downwards site angle for the bottom Kara II in stacked configurations.

The KARA-MINIBUEX package comprises the following elements:

- Two rigging plates featuring two rubber feet each.
- Six bolts to assemble the KARA-MINIBU frame and two KARA-MINIBUEX plates.
- Four 5/16" T-BLP (T-shaped ball-locking pins) to attach an SB18 enclosure to the KARA-MINIBU/KARA-MINIBUEX structure.

The KARA-ANGARMEX package comprises two angle arm extensions with 5/16" T-BLP.

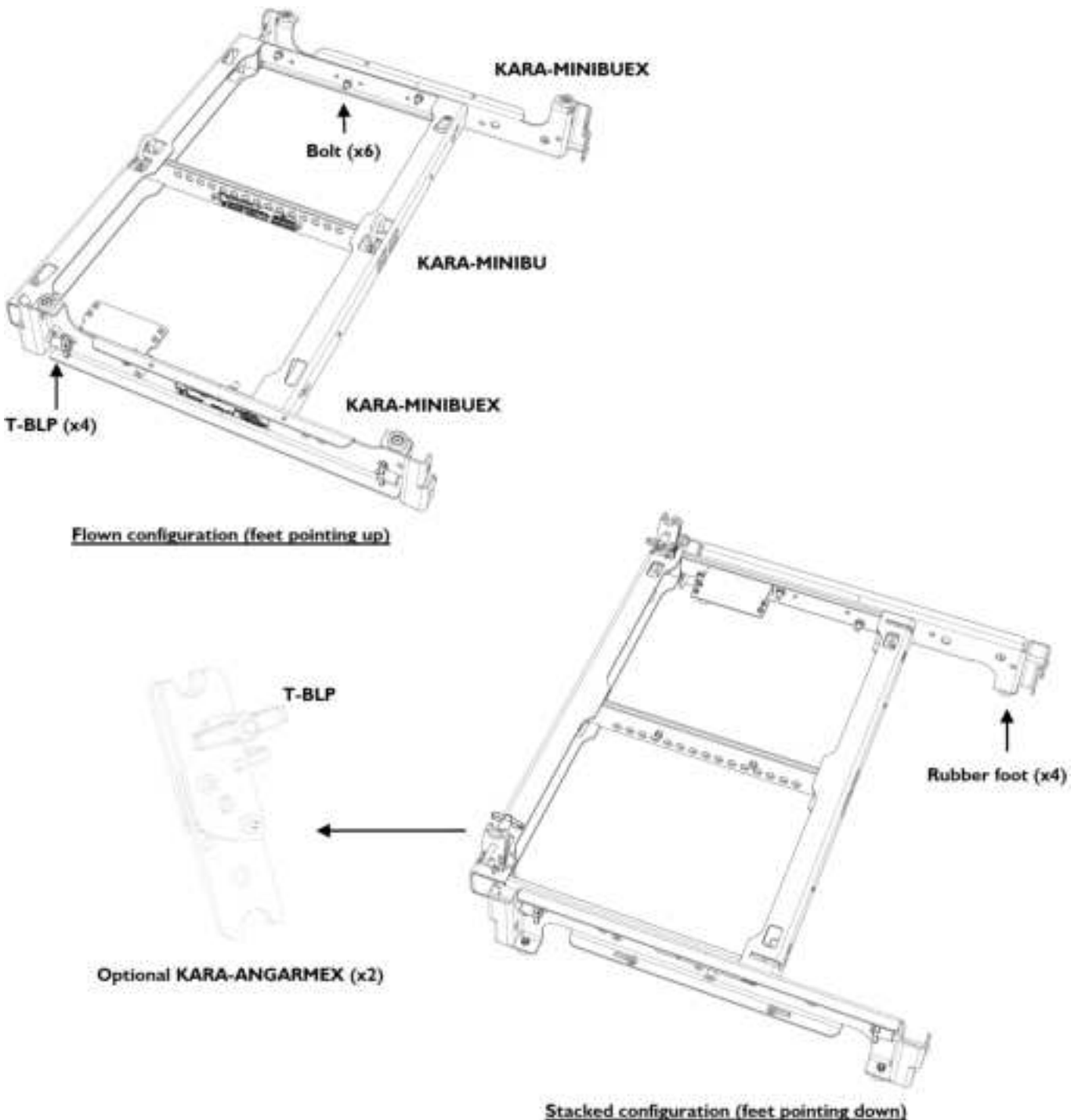

KARA-PULLBACK

The L-Acoustics KARA-PULLBACK rigging accessory will allow setting the Kara II array in a pullback configuration. It connects to the bottom enclosure of the array and to the hook or stinger of an additional motor.

The KARA-PULLBACK is a plate on which is fixed one shackle fitted with 19 mm/0.75 inch-diameter axis.

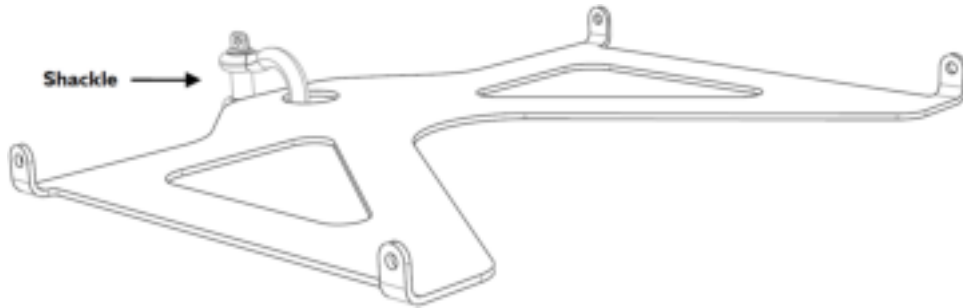

Transportation

Flight-case

It is recommended to use a flight-case designed to ship a 3-Kara II vertical array. It should contain foam inserts to prevent array movement and the tray should be fitted with 2 wedges to keep the array vertical.



Complete flight-case



Tray supporting a 3-Kara II array

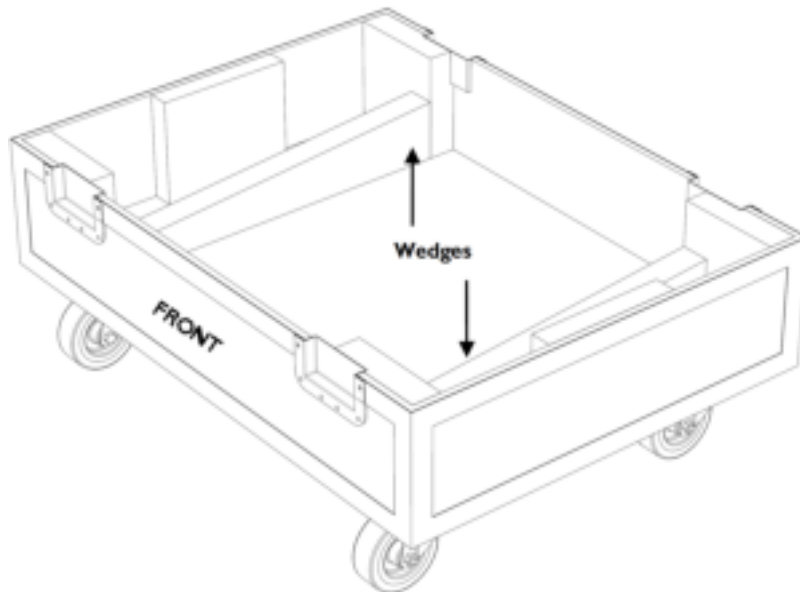

Tray detail

Mechanical safety

Flown configurations

The Kara II rigging system complies with 2006/42/EC: Machinery Directive. It has been designed following the guidelines of BGV-C1.

2006/42/EC: Machinery Directive specifies a safety factor of 4 against the rupture. The flown deployments described in this manual achieve a safety factor of **4 or more**.

Refer to Soundvision for the safety factor of a specific deployment.

The **safe limit** gives the maximum number of elements for which the safety factor is compliant with the 2006/42/EC: Machinery Directive, within the use defined in this manual and regardless of the other deployment parameters (site angles, inter-element angles, etc.).

The **maximum limit** gives the maximum number of elements for which the safety factor can be compliant with the 2006/42/EC: Machinery Directive, when the other deployment parameters provide the best mechanical conditions.

For mixed arrays refer to your Soundvision model.

Kara II

configuration	rigging accessory	safe limit	maximum limit
flown	M-BUMP + M-BAR (optional)	16	24
	KARA-MINIBU		6
pullback	M-BUMP + KARA-PULLBACK		16
	KARA-MINIBU + KARA-PULLBACK		6

SB18

configuration	rigging accessory	maximum / safe limit
flown	M-BUMP + M-BAR (optional)	16
	KARA-MINIBU + KARA-MINIBUEX	4

Kara II + SB18

configuration	rigging accessory	maximum / safe limit
pullback	M-BUMP + KARA-PULLBACK	9 Kara II + 3 SB18
	KARA-MINIBU + KARA-MINIBUEX + KARA-PULLBACK	6 Kara II + 2 SB18

Other configurations

For other configurations, respect the recommended maximum limit for optimal stability.

Kara II

configuration	rigging accessory	maximum / safe limit
platform-stacked	M-BUMP + M-BAR + M-JACK + KARA-ANGARMEX (optional)	9
	KARA-MINIBU + KARA-MINIBUEX + KARA-ANGARMEX (optional)	6
ground-stacked	no rigging accessory	2

SB18

configuration	rigging accessory	maximum / safe limit
platform-stacked	M-BUMP + M-BAR + M-JACK	4
ground-stacked	no rigging accessory	4

Assessing mechanical safety**Mechanical safety of the rigging system**

Before any installation, always model the system in Soundvision and check the **Mechanical Data** section for any stress warning or stability warning.

In order to assess the actual safety of any array configuration before implementation, refer to the following warnings:

**Rated working load limit (WLL) is not enough**

The rated WLL is an indication of the element resistance to tensile stress. For complex mechanical systems such as loudspeaker arrays, WLLs cannot be used per se to determine the maximum number of enclosures within an array or to assess the safety of a specific array configuration.

Maximum pullback angle

If a pullback accessory is available, the pullback angle must not exceed a 90° negative site angle.

Mechanical modeling with Soundvision

The working load applied to each linking point, along with the corresponding safety factor, will depend on numerous variables linked to the composition of the array (type and number of enclosures, splay angles) and the implementation of the flying or stacking structure (number and location of flying points, site angle). This cannot be determined without the complex mechanical modeling and calculation offered by Soundvision.

Assessing the safety with Soundvision

The overall safety factor of a specific mechanical configuration always corresponds to the lowest safety factor among all the linking points. Always model the system configuration with the Soundvision software and check the **Mechanical Data** section to identify the weakest link and its corresponding working load. By default, a stress warning will appear when the mechanical safety goes beyond the recommended safety level.

Safety of ground-stacked arrays in Soundvision

For ground-stacked arrays, a distinct stability warning is implemented in Soundvision. It indicates a tipping hazard when the array is not secured to the ground, stage or platform. It is the user's responsibility to secure the array and to ignore the warning.

Additional safety for flown arrays

When flying an array, use available holes to implement a secondary safety.

Considerations must be given to unusual conditions

Soundvision calculations are based on usual environmental conditions. A higher safety factor is recommended with factors such as extreme high or low temperatures, strong wind, prolonged exposition to salt water, etc. Always consult a rigging specialist to adopt safety practices adapted to such a situation.

Loudspeaker configurations



Avoid using Kara and Kara II in the same line source

The acoustic coupling between Kara and Kara II is not optimal.

Line source

Deployed as a standalone line source, a Kara II system operates over the nominal bandwidth of the Kara II enclosure, with an adjustable horizontal directivity.

The [KARA II 70], [KARA II 90], and [KARA II 110] presets deliver a reference frequency response in long throw applications. Each preset is dedicated to a horizontal directivity setting (see [Adjustable fins](#) (p.13)).

The Kara II enclosure is driven by the LA4X / LA8 / LA12X amplified controllers.

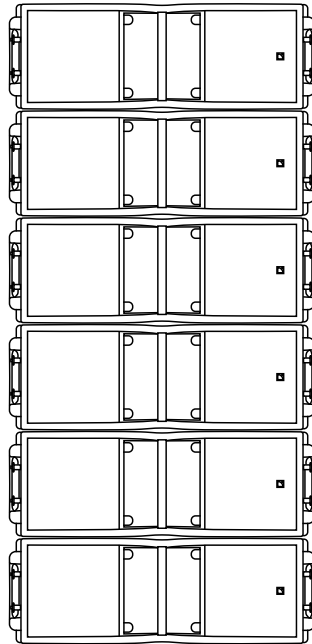

Enclosure	Kara II
Preset	[KARA II 70] [KARA II 90] [KARA II 110]
Frequency range (-10 dB)	55 Hz - 20 kHz

Line source with low-frequency element

A Kara II line source can be deployed with additional subwoofer enclosures to extend the bandwidth in the low end or increase sub-low resources.

Three configurations are available:

- Coupled SB18 or KS21* - ratio 3:1
- Separated SB18 or KS21 - ratio 3:2
- Coupled SB18 or KS21* with KS28 or SB28 - ratio 3:1:1

The [xxxx_60] or [xxxx_100] presets provide the subwoofers with an upper frequency limit at 60 Hz in separated configuration, or 100 Hz in closely coupled configuration, for an optimal frequency coupling with the Kara II line source.

Amplified controllers compatibility

	LA4X	LA8	LA12X
Kara II	✓	✓	✓
SB18	✓	✓	✓
KS21	✓	✓	✓
SB28	—	✓	✓
KS28	—	—	✓

Coupled SB18 or KS21

3 Kara II : 1 SB18 or KS21*

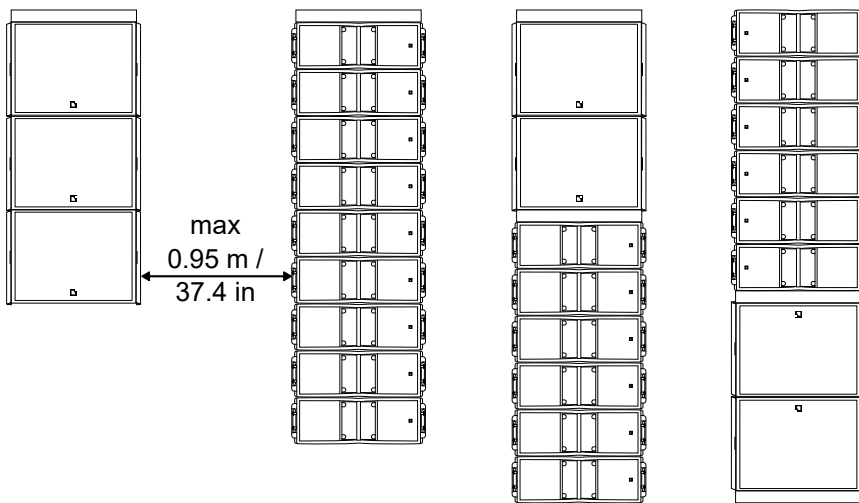

i Maximum number of enclosures in mixed lines for optimal acoustic coupling:
9 Kara II + 3 SB18

Enclosure	Kara II	SB18 or KS21
Preset	[KARA II 70] [KARA II 90] [KARA II 110]	[xxxx_100]
Frequency range (-10 dB)	32 Hz - 20 kHz with SB18 31 Hz - 20 kHz with KS21	

! Grouping subwoofers

Place the subwoofer enclosures side by side. If not possible, the maximum distance between two adjacent acoustic centers must be 1.7 m if the upper frequency limit of the subwoofer system is at 100 Hz.

* KS21 cannot be mechanically coupled with a Kara II line source in an array. The KS21 and Kara II arrays must be flown independently. Refer to the **KS21 owner's manual** for more information on how to set up a KS21 array.

! Use [xxxx_xx_C] or [xxxx_xx_Cx] on a reversed subwoofer in a cardioid configuration

The cardioid configuration consists in reversing 1 element in an array of 4 subwoofers.

Refer to the subwoofer owner's manual and to the **Cardioid configurations** technical bulletin.

! Delay values

Do not forget to add the pre-alignment and geometric delays depending on the configuration.

Pre-alignment delays

presets	pre-alignment delay values and polarity settings			
[KARA II] + [SB18_100]	Kara II = 0 ms	+	SB18 = 0 ms	+
[KARA II] + [SB18_100_C]	Kara II = 5.5 ms	+	SB18 = 0 ms	+
[KARA II] + [SB18_100_Cx]	Kara II = 4 ms	+	SB18 = 0 ms	-
[KARA II] + [KS21_100]	Kara II = 0 ms	+	KS21 = 0.5 ms	+
[KARA II] + [KS21_100_C]	Kara II = 5 ms	+	KS21 = 0 ms	+
[KARA II] + [KS21_100_Cx]	Kara II = 4 ms	+	KS21 = 0 ms	-

Separated SB18 or KS21

3 Kara II : 2 SB18 or KS21

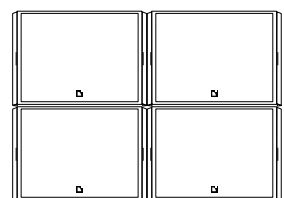
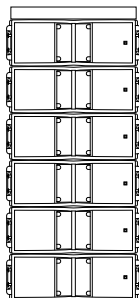

Enclosure	Kara II	SB18 or KS21
Preset	[KARA II 70] [KARA II 90] [KARA II 110]	[xxxx_60]
Frequency range (-10 dB)	32 Hz - 20 kHz with SB18 29 Hz - 20 kHz with KS21	

**Grouping subwoofers**

Place the subwoofer enclosures side by side. If not possible, the maximum distance between two adjacent acoustic centers must be 2.8 m if the upper frequency limit of the subwoofer system is at 60 Hz.

**Use [xxxx_xx_C] or [xxxx_xx_Cx] on a reversed subwoofer in a cardioid configuration**













The cardioid configuration consists in reversing 1 element in an array of 4 subwoofers.

Refer to the subwoofer owner's manual and to the **Cardioid configurations** technical bulletin.

**Delay values**

Do not forget to add the pre-alignment and geometric delays depending on the configuration.

Pre-alignment delays

presets	pre-alignment delay values and polarity settings	
[KARA II] + [SB18_60]	Kara II = 2.5 ms 	SB18 = 0 ms 
[KARA II] + [SB18_60_C]	Kara II = 8 ms 	SB18 = 0 ms 
[KARA II] + [SB18_60_Cx]	Kara II = 6.5 ms 	SB18 = 0 ms 
[KARA II] + [KS21_60]	Kara II = 0.5 ms 	KS21 = 0 ms 
[KARA II] + [KS21_60_C]	Kara II = 6 ms 	KS21 = 0 ms 
[KARA II] + [KS21_60_Cx]	Kara II = 5.5 ms 	KS21 = 0 ms 

Coupled SB18 or KS21 with KS28 or SB28

3 Kara II : 1 SB18 or KS21* : 1 SB28 or KS28

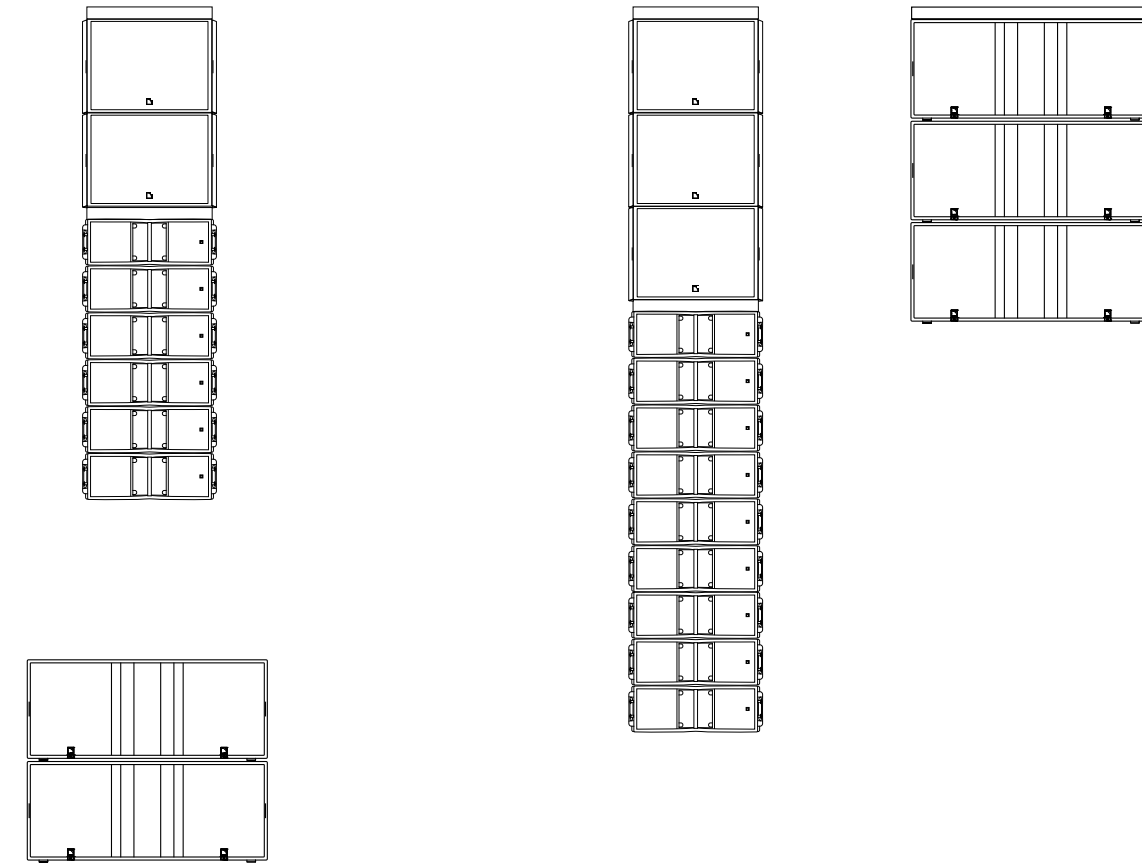

i Maximum number of enclosures in mixed lines for optimal acoustic coupling:
9 Kara II + 3 SB18

Enclosure	Kara II	SB18 or KS21	SB28 or KS28
Preset	[KARA II 70] [KARA II 90] [KARA II 110]	[xxx_100]	[xx28_60]
Frequency range (-10 dB)	25 Hz - 20 kHz		

! Grouping subwoofers

Place the subwoofer enclosures side by side. If not possible, the maximum distance between two adjacent acoustic centers must be 2.8 m if the upper frequency limit of the subwoofer system is at 60 Hz.

! Use [xxxx_xx_C] or [xxxx_xx_Cx] on a reversed subwoofer in a cardioid configuration

The cardioid configuration consists in reversing 1 element in an array of 4 subwoofers.

Refer to the subwoofer owner's manual and to the **Cardioid configurations** technical bulletin.

* KS21 cannot be mechanically coupled with a Kara II line source in an array. The KS21 and Kara II arrays must be flown independently. Refer to the **KS21 owner's manual** for more information on how to set up a KS21 array.

! Delay values

Do not forget to add the pre-alignment and geometric delays depending on the configuration.

Pre-alignment delays

preset	pre-alignment delay values and polarity settings		
[KARA II] + [SB18_100] + [SB28_60]	Kara II = 0 ms <input style="background-color: #cccccc;" type="button" value="+"/>	SB18 = 0 ms <input style="background-color: #cccccc;" type="button" value="+"/>	SB28 = 5.5 ms <input style="background-color: #cc0000;" type="button" value="-"/>
[KARA II] + [SB18_100] + [SB28_60_C]	Kara II = 0 ms <input style="background-color: #cccccc;" type="button" value="+"/>	SB18 = 0 ms <input style="background-color: #cccccc;" type="button" value="+"/>	SB28 = 0 ms <input style="background-color: #cc0000;" type="button" value="-"/>
[KARA II] + [SB18_100] + [SB28_60_Cx]	Kara II = 5.5 ms <input style="background-color: #cccccc;" type="button" value="+"/>	SB18 = 5.5 ms <input style="background-color: #cccccc;" type="button" value="+"/>	SB28 = 0 ms <input style="background-color: #cccccc;" type="button" value="+"/>
[KARA II] + [SB18_100] + [KS28_60]	Kara II = 0 ms <input style="background-color: #cccccc;" type="button" value="+"/>	SB18 = 0 ms <input style="background-color: #cccccc;" type="button" value="+"/>	KS28 = 5.5 ms <input style="background-color: #cc0000;" type="button" value="-"/>
[KARA II] + [SB18_100] + [KS28_60_C]	Kara II = 0 ms <input style="background-color: #cccccc;" type="button" value="+"/>	SB18 = 0 ms <input style="background-color: #cccccc;" type="button" value="+"/>	KS28 = 0 ms <input style="background-color: #cc0000;" type="button" value="-"/>
[KARA II] + [SB18_100] + [KS28_60_Cx]	Kara II = 5.5 ms <input style="background-color: #cccccc;" type="button" value="+"/>	SB18 = 5.5 ms <input style="background-color: #cccccc;" type="button" value="+"/>	KS28 = 0 ms <input style="background-color: #cccccc;" type="button" value="+"/>
[KARA II] + [KS21_100] + [SB28_60]	Kara II = 0 ms <input style="background-color: #cccccc;" type="button" value="+"/>	KS21 = 0.5 ms <input style="background-color: #cccccc;" type="button" value="+"/>	SB28 = 5.5 ms <input style="background-color: #cc0000;" type="button" value="-"/>
[KARA II] + [KS21_100] + [SB28_60_C]	Kara II = 0 ms <input style="background-color: #cccccc;" type="button" value="+"/>	KS21 = 0.5 ms <input style="background-color: #cccccc;" type="button" value="+"/>	SB28 = 0 ms <input style="background-color: #cc0000;" type="button" value="-"/>
[KARA II] + [KS21_100] + [SB28_60_Cx]	Kara II = 5.5 ms <input style="background-color: #cccccc;" type="button" value="+"/>	KS21 = 6 ms <input style="background-color: #cccccc;" type="button" value="+"/>	SB28 = 0 ms <input style="background-color: #cccccc;" type="button" value="+"/>
[KARA II] + [KS21_100] + [KS28_60]	Kara II = 0 ms <input style="background-color: #cccccc;" type="button" value="+"/>	KS21 = 0 ms <input style="background-color: #cccccc;" type="button" value="+"/>	KS28 = 5.5 ms <input style="background-color: #cc0000;" type="button" value="-"/>
[KARA II] + [KS21_100] + [KS28_60_C]	Kara II = 0 ms <input style="background-color: #cccccc;" type="button" value="+"/>	KS21 = 0.5 ms <input style="background-color: #cccccc;" type="button" value="+"/>	KS28 = 0 ms <input style="background-color: #cc0000;" type="button" value="-"/>
[KARA II] + [KS21_100] + [KS28_60_Cx]	Kara II = 5.5 ms <input style="background-color: #cccccc;" type="button" value="+"/>	KS21 = 6 ms <input style="background-color: #cccccc;" type="button" value="+"/>	KS28 = 0 ms <input style="background-color: #cccccc;" type="button" value="+"/>

Line source element

One or two Kara II can be used as a line source element. In this configuration, the system operates without the low-end of the bandwidth.

The [KARA II_FI] presets delivers a flat frequency response for short throw applications and a high-pass filter at 100 Hz.

! The [KARA II_FI] preset is optimized for a **110°** fins setting (see [Adjustable fins](#) (p.13)).

The Kara II enclosure is driven by the LA4X / LA8 / LA12X amplified controllers

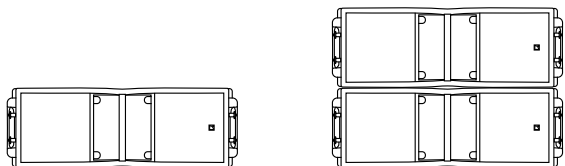

Enclosure	Kara II
Preset	[KARA II_FI]
Frequency range (-10 dB)	85 Hz - 20 kHz

Inspection and preventive maintenance

How to do preventive maintenance

Inspect the system before any deployment and after any corrective maintenance operation.

Perform preventive maintenance at least once a year.

Rigging and hardware

Perform the [Rigging part inspection](#) (p.39) on each rigging part.

Use the [Mechanical system overview](#) (p.40) to identify critical parts of the system and apply the specific checks described in the [Inspection references](#) (p.47).

Do the [Rigging check](#) (p.44).

If any parts are damaged, contact your L-Acoustics representative for further instructions.

Acoustics

Perform the [Enclosure check](#) (p.50).

Perform the [Listening test](#) (p.52) to detect any degradation in sound quality.

If necessary, refer to the [Corrective maintenance](#) (p.147) section for speaker repair kits and maintenance instructions.

Rigging part inspection

About this task

For critical rigging parts, use the [Inspection references](#) (p.47) for comparison and specific manipulations.

The term "rigging part" comprises:

- lifting accessories such as clamps and shackles
- rigging accessories such as rigging frames, rigging interfaces, and brackets
- fasteners used for assembling two products together such as ball-locking pins, rigging axes, and safety pins
- rigging elements integrated in the product such as rigging arms and rails
- transportation accessories

This inspection procedure covers only L-Acoustics products. To inspect other products that are part of the lifting chain, refer to the manufacturer's instructions.

Prerequisite

Perform the inspection in a well-lit environment.

Procedure

1. Check that the rigging part is present.
2. If applicable, disassemble the rigging part from the enclosure or the rigging accessory.

Check that the tethers are intact and safely secured.

3. Inspect the part from every side.

Compare with the **reference pictures**.

Check for:

- corrosion
- wear and cracks
- bends and dents
- holes
- missing safety cues
- missing identification labels

- missing or loose fasteners



Replacing screws

If a screw is loose, remove and replace it.

Always use the new screws provided in the repair kit.

If no new screw is available, add blue threadlocker before reusing the screw.

Do not apply more than the indicated torque.

4. Check the **geometry** of the part to identify critical deformations.

Place the rigging part on a flat surface or hold a level against it.

5. Check the **moving parts**.

Make sure that the mechanism engages correctly.



What to do next

If a problem is detected, perform the authorized maintenance operations or contact your L-Acoustics representative.

Mechanical system overview

Critical parts of the lifting chains are highlighted.



The  indicates a visual inspection. The  indicates a functional check.



Perform the [Rigging part inspection](#) (p.39) on critical parts.

For each part, refer to the [Inspection references](#) (p.47).



Replacing screws

If a screw is loose, remove and replace it.

Always use the new screws provided in the repair kit.

If no new screw is available, add blue threadlocker before reusing the screw.

Do not apply more than the indicated torque.

Mixed Kara II array with SB18 and M-BUMP

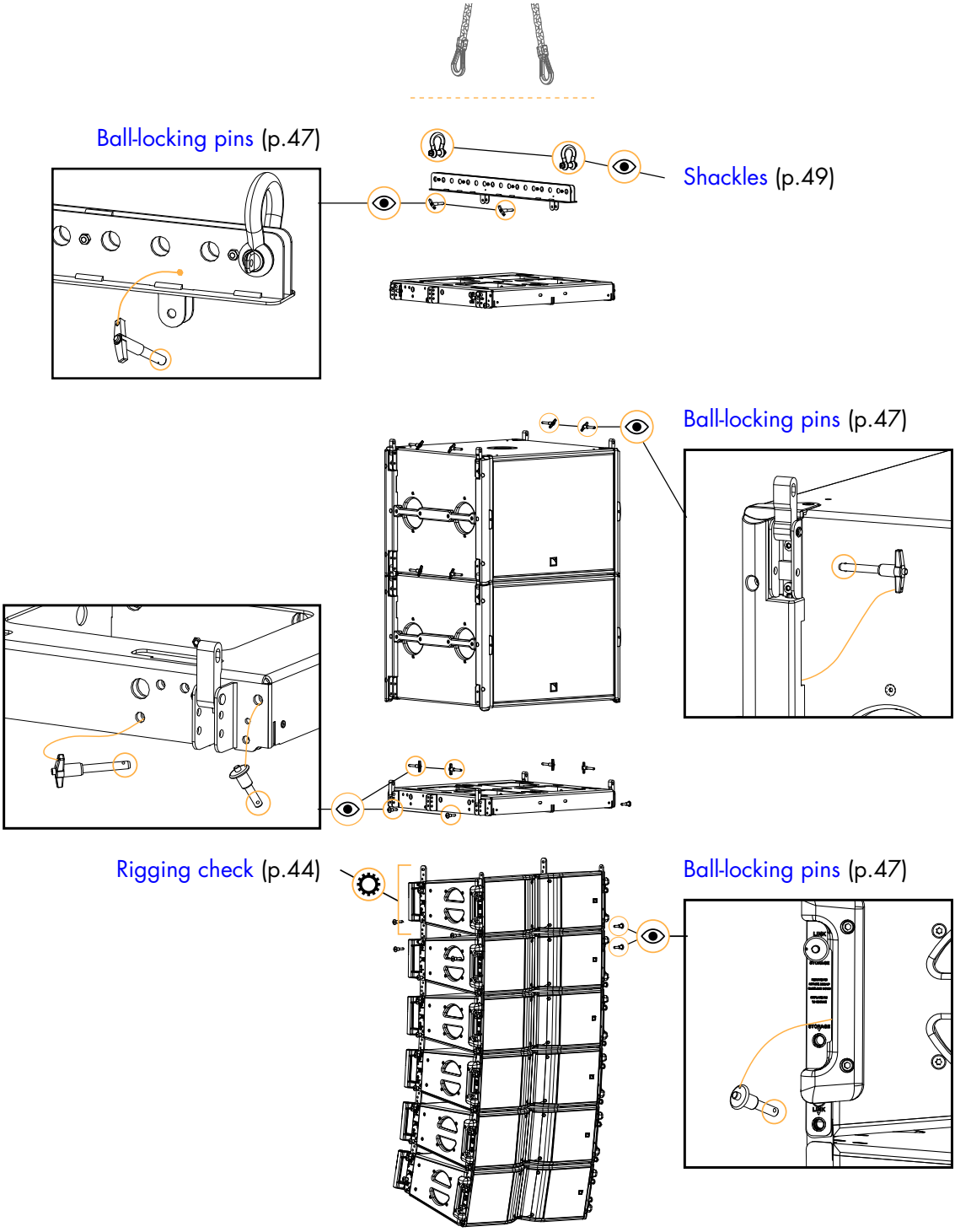

Mixed Kara II array with SB18, KARA-MINIBU/KARA-MINIBUEX and KARA-PULLBACK



screws are tightened

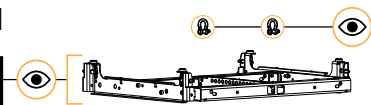
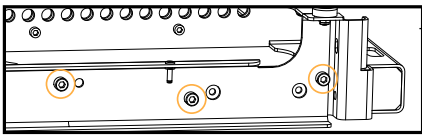

Shackles (p.49)

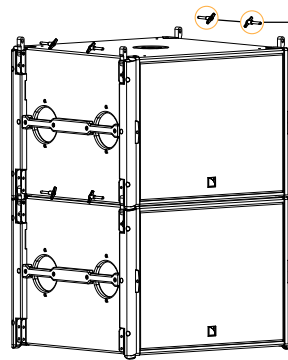

Ball-locking pins (p.47)

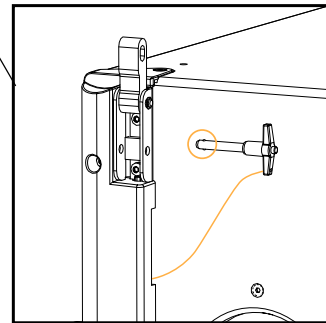

Ball-locking pins (p.47)

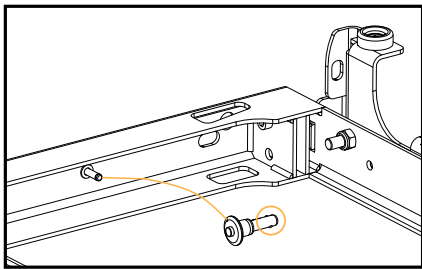

Ball-locking pins (p.47)

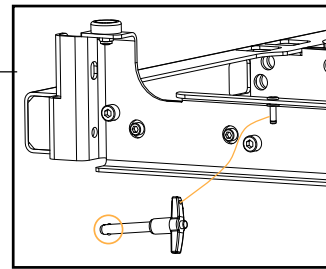
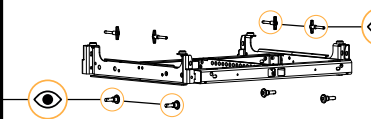

Rigging check (p.44)

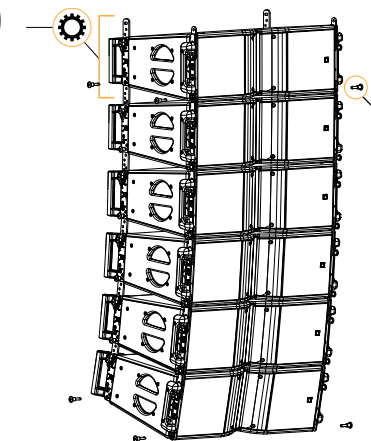

Ball-locking pins (p.47)

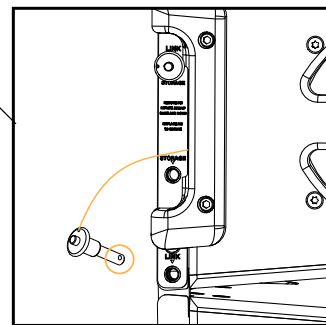

Shackles (p.49)



tabs are not bent

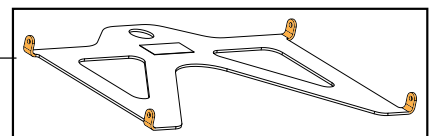

Rigging check

Prerequisite

Check that the front rigging plates of the Kara II enclosure are not loose.

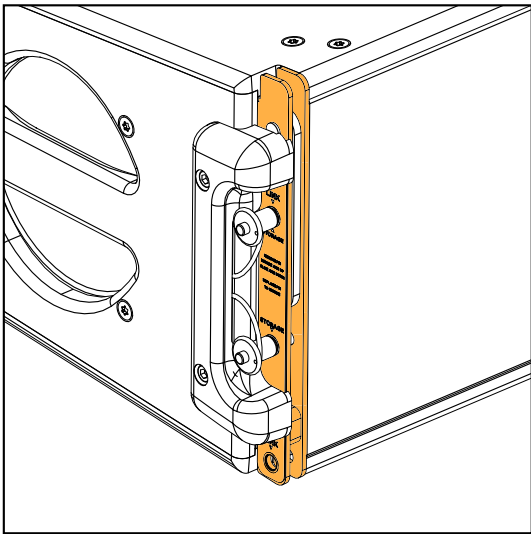

Procedure

1. Secure the front rigging arms at rigging position.

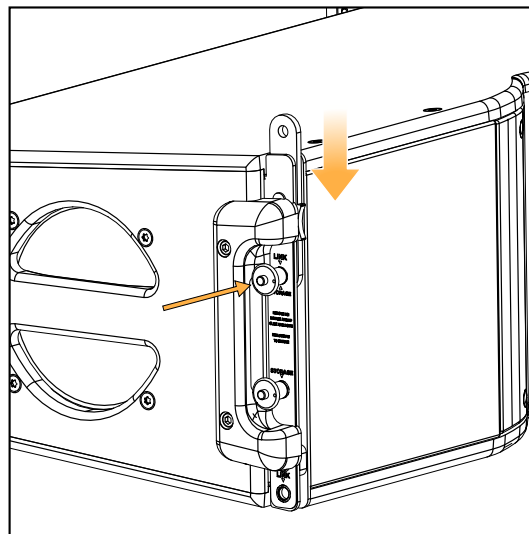
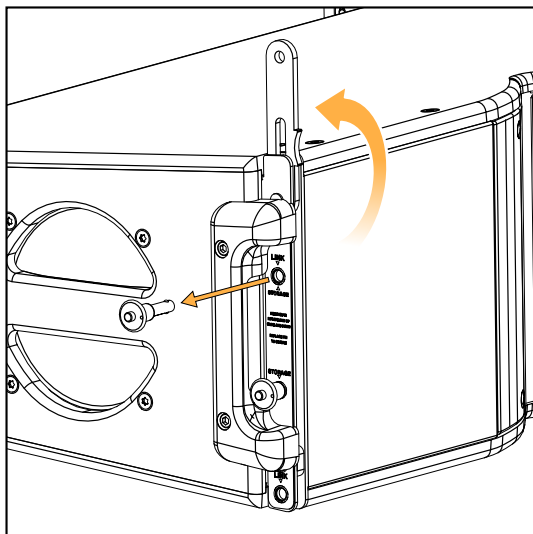

- The rigging arms slide and rotate correctly.

2. Secure the rear rigging arms at the 0° position.

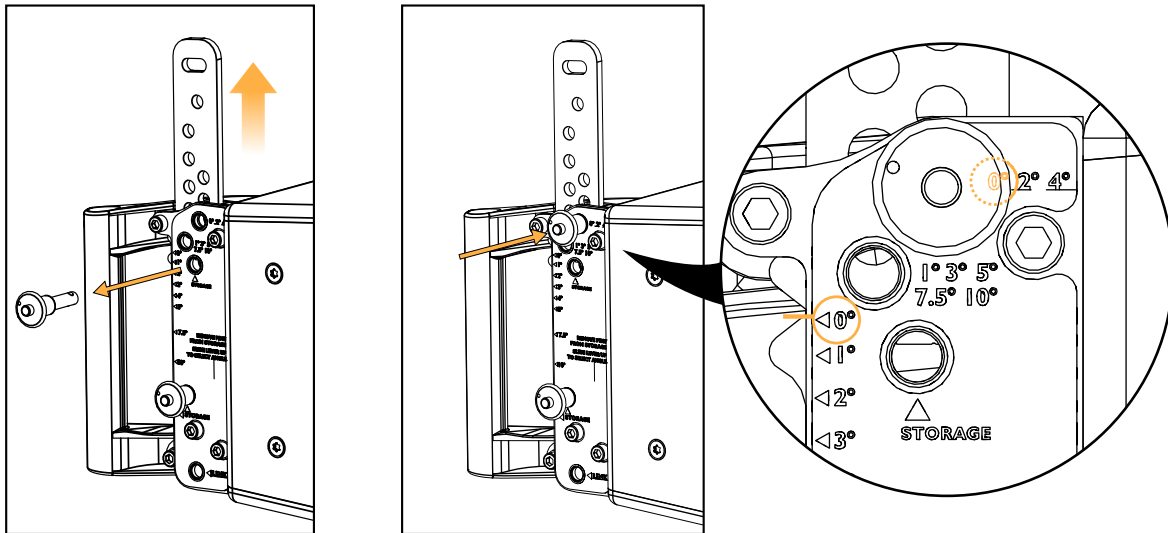

- The rigging arms slide correctly.

3. Secure a second Kara II on top of the first Kara II.

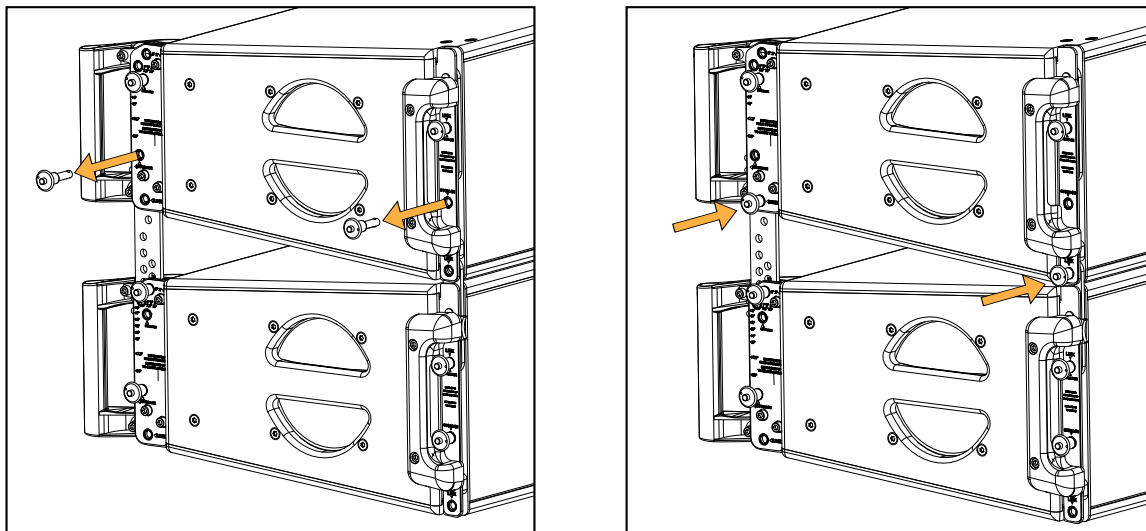

4. Hold the top enclosure by the handles and shake the assembly.

- The two enclosures remain attached.

5. Remove the ball-locking pins of the top enclosure to separate it from the bottom enclosure.

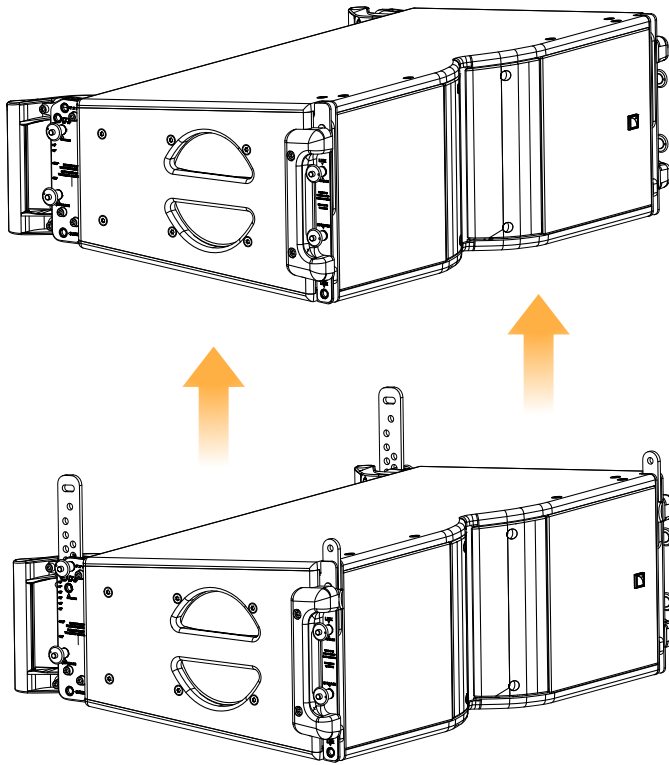

6. Remove the ball-locking pins of the bottom enclosure to release the rigging arms.
7. Secure the rigging arms and the ball-locking pins at their storage positions.
8. Repeat the procedure with the other enclosures.

Inspection references

Ball-locking pins

Reference pictures

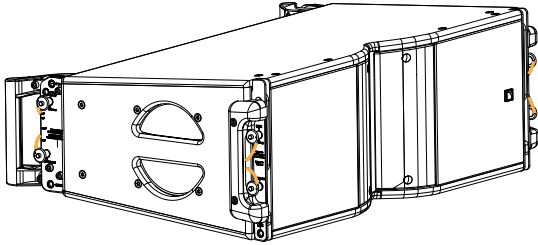

tether (Kara II)

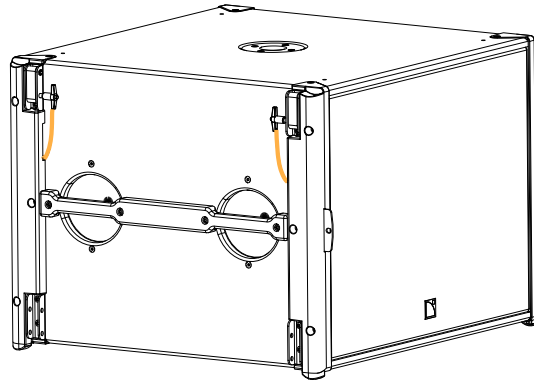

tether (SB18)

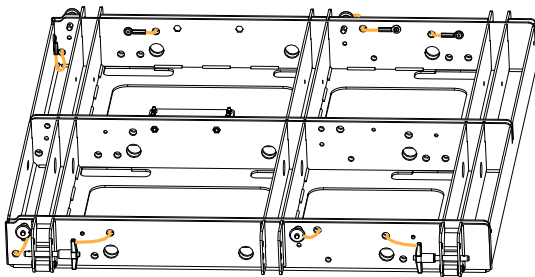

tether (M-BUMP)

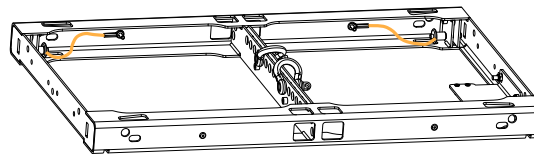

tether (KARA-MINIBU)

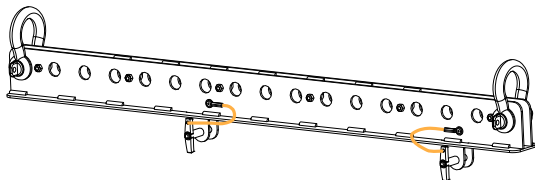

tether (M-BAR)

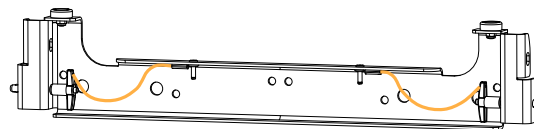

tether (KARA-MINIBUEX)

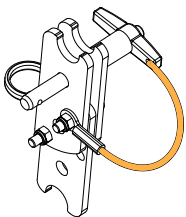

tether (KARA-ANGARMEX)

Moving parts

1. Press the push button. The ball-locking mechanism is retracted.
2. Release the button. The ball-locking mechanism is activated.

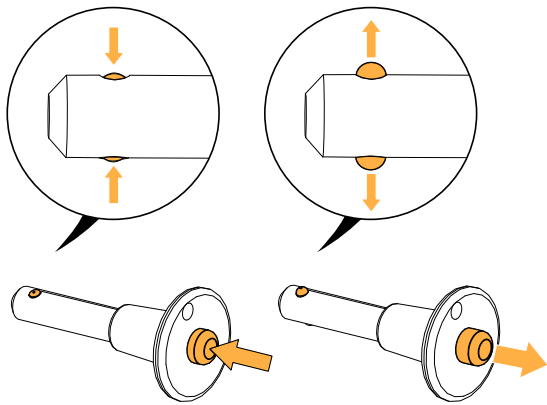

- 3.** Insert the pin in each storage and rigging hole. Pull and rotate the pin. The pin must remain inside the hole.

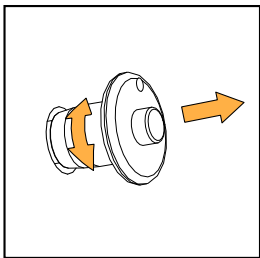

If the pin is inserted in two plates, the ball must pass through both plates and lock the pin in place.

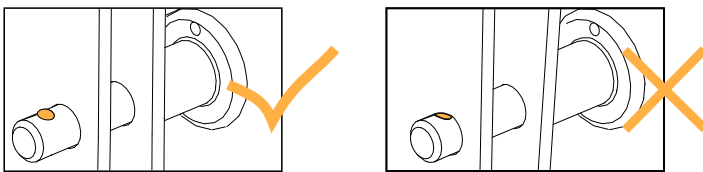

If the check fails, **immediately withdraw the product from use and contact L-Acoustics.**

Related tasks

[Rigging part inspection \(p.39\)](#)

Shackles

Moving parts

Drive the shackle axis in its lodging. Make sure that the end is flush with the shackle.

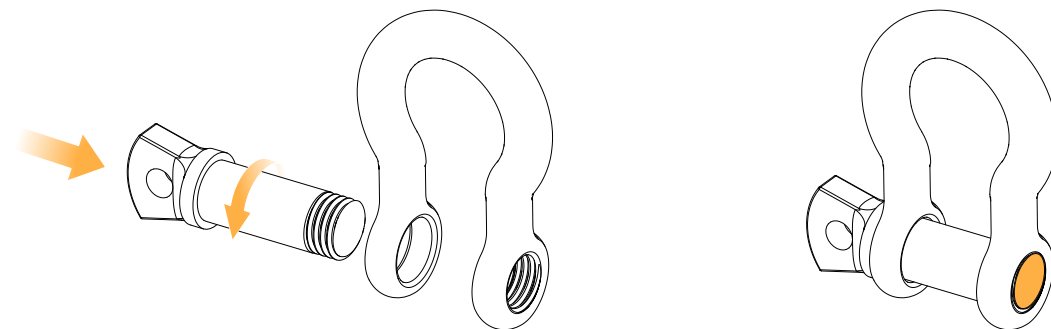

Related tasks

[Rigging part inspection \(p.39\)](#)

Acoustical check

Enclosure check



This feature is available on:

LA4X
LA12X

ENCLOSURE CHECK measures impedance at the reference frequencies for the connected loudspeaker family. The measured impedance is compared to the expected range allowing for fast detection of loudspeakers presenting circuit continuity issues.



The results can be used for preliminary diagnosis but cannot replace a comprehensive quality control.

Prerequisite



ENCLOSURE CHECK measurements can only be reliable if the following requirements are met:

Environment and temperature:

- Ambient temperature must be comprised between 0 °C / 32 °F and 40 °C / 104 °F. Ideal temperature is 20 °C / 68 °F.
- Enclosures must be at room temperature. If warm from a recent high level use or recently moved from a cold environment, let the loudspeakers reach room temperature before starting.

Enclosures:

- Enclosures must be included in the embedded factory preset library.
- Enclosures must be in nominal operating conditions:
 - Remove covers or dollies obstructing the loudspeakers or the vents.
 - Check for obvious physical damage or air leak: visually inspect the grill, gasket, cabinet, and connector plate for loose, missing or damaged parts.

Connection:

- Use only 10 m / 30 ft 4 mm² / AWG 11 speaker cables.
- Do not connect enclosures in parallel.

Amplified controllers:

- LA4X must run at least firmware version 1.1.0.
- LA4X load sensors must be calibrated. Refer to the **Load Sensor Calibration Tool** technical bulletin for more information.
- LA4X must warm up for at least 10 minutes after power up. Do not power off, reboot or switch to standby mode to avoid resetting the countdown.
- Load a preset corresponding to the connected loudspeaker's family. Presets from the user memories may be used on condition they are made of presets supported in the embedded factory preset library.

Procedure

1. Power up the amplified controller. Let LA4X warm up for at least 10 minutes.
2. Connect the loudspeaker enclosures to the amplified controller.
3. Load a preset from or built from the embedded library corresponding to the connected loudspeaker family.
4. On the amplified controller, use the encoder wheel to select **MONITORING & INFO**. Press the OK key or the encoder wheel to validate.
5. Use the encoder wheel to select **ENCLOSURE CHECK**.



Beware of sound levels.

Although the sound pressure levels generated for the ENCLOSURE CHECK are moderate, do not stay within close proximity of the loudspeakers and consider wearing ear protection.

6. Press the OK key or the encoder wheel to launch the ENCLOSURE CHECK.

The amplified controller generates short sinusoidal signals simultaneously for each connected output.

The amplified controller displays the results for each output.

7. Depending on the displayed results, follow the instructions in the table.

result	interpretation	instructions
OK	measured impedance is within expected range	enclosure is in working order electrically
?	unsupported preset family	only supported enclosures should be tested
NC	Not Connected	if cables are connected: a. inspect the cables and connections b. go to step 8 (p.51)
NOK	measured impedance is not within expected range	a. check that all the prerequisites are met, in particular that the loaded preset corresponds to the connected speaker's family b. inspect the cables and connections c. go to step 8 (p.51)
UNDEF	measured impedance is undefined	

8. Under NC, NOK and UNDEF results, press and hold the corresponding OUT key.

The amplified controller displays:

- the tested frequencies,
- information on the measured impedance:
 - OPEN for open circuit (found in NC results),
 - SHORT for short circuit (found in NOK results), or
 - a percentage of variation from the expected range (found in NOK and UNDEF results)
- the number of operational transducers out of the total



Low variations from the expected range are acceptable: displayed percentage can be different from 0 and all transducers considered operational.

Listening test

enclosure	preset	usable bandwidth
Kara II	[KARA II 70]	55 Hz - 20 kHz
SB18	[SB18_100]	32 Hz - 110 Hz

Procedure

1. Load the preset on an LA4X / LA8 / LA12X amplified controller.
2. Connect a sinus generator to the amplified controller.



Risk of hearing damage

Set a low sound level to start and use ear protection to adjust before testing.

3. Scan the bandwidth focusing on the usable range.
The sound should remain pure and free of unwanted noise.

Troubleshooting for LF speakers

One or more LF speaker produces distorted, buzzing, rubbing, clicking, muffled or weak sound.

Possible causes

- The screws are not tightened with the appropriate torque.
- There is an air leak in the gasket.
- There is dust on the cone.
- The cone is damaged.
- The surround is torn or delaminated.
- The voice coil or the spider is damaged.

Procedure

1. Perform the speaker disassembly procedure.
2. Visually inspect the cables and the connectors.
3. Visually inspect the speaker cone, the voice coil and the spider.

If any damage is visible, replace the speaker.

4. Carefully clean the speaker with a dry cloth.
5. Perform the reassembly procedure.
Replace the speaker gasket and the screws.
Apply the recommended torque.

6. Repeat the listening test.

If the problem persists, replace the speaker.

Troubleshooting for HF drivers

One or more HF driver produces high-frequency harmonic distortions, strange vibrations or weak sound.

Possible causes

- There are foreign particles on the air gap.
- The diaphragm is not centered correctly.
- The screws used for reassembly are too loose.
- The diaphragm is damaged.

Procedure

1. Perform the diaphragm disassembly procedure.
2. Visually inspect the diaphragm and the voice coil.

If any damage is visible, replace the diaphragm.

- 3.** Clean the air gap thoroughly.
Use double-face adhesive tape to remove any particles.
- 4.** Perform the diaphragm reassembly procedure.
Apply the recommended torque.
- 5.** Repeat the listening test.
If the problem persists, replace the driver.

Rigging procedures

Flying a Kara II standalone array

Using M-BUMP

Modeling and safety

Any system must be modeled before installation so as to ensure acoustical and mechanical conformity. This can be done using L-Acoustics [Soundvision Software](#) which will assist the user to:

- Determine the number of required Kara II enclosures.
- Calculate the M-BUMP site angle and the inter-enclosure angles.
- Check the mechanical conformity of the system.

! The M-BUMP can nominally fly an array of up to 24 Kara II along with all loudspeakers cables (refer to [Mechanical safety](#) (p.31)). However, this maximum number can decrease in line with the array curvature. Always refer to the mechanical data and warning indications provided in [Soundvision Software \(Mechanical Data section\)](#) to verify the mechanical conformity of the system before installation.

The Kara II and M-BUMP fully integrated rigging systems allow assembling the array with no need for any external accessory.

The following first procedure describes how to fly a vertical Kara II array under an M-BUMP. It is recommended to rig the Kara II by successively adding arrays of 3 enclosures (called ARRAY#1, ARRAY#2... in the order of appearance in the procedure).

The second procedure describes how to disassemble the array.

Array mounting

About this task

! All along the procedure:
 Strictly follow the sequence of the successive steps.
 Systematically verify that each BLP is fully inserted.
 Systematically verify that the bolt is fully screwed in on each shackle.

! For clarity purposes the loudspeaker cabling procedure will not be described.
 The loudspeaker cables will not be represented on the figures.
 Use a strain relief to avoid mechanical stress at the connector locations due to cable weight.
 The motor hooks or stingers will not be represented on the figures.

Procedure

1. Place an M-BUMP at the rigging location. Turn it so that the text of the identification plate is readable and the laser slits are directed towards the audience.

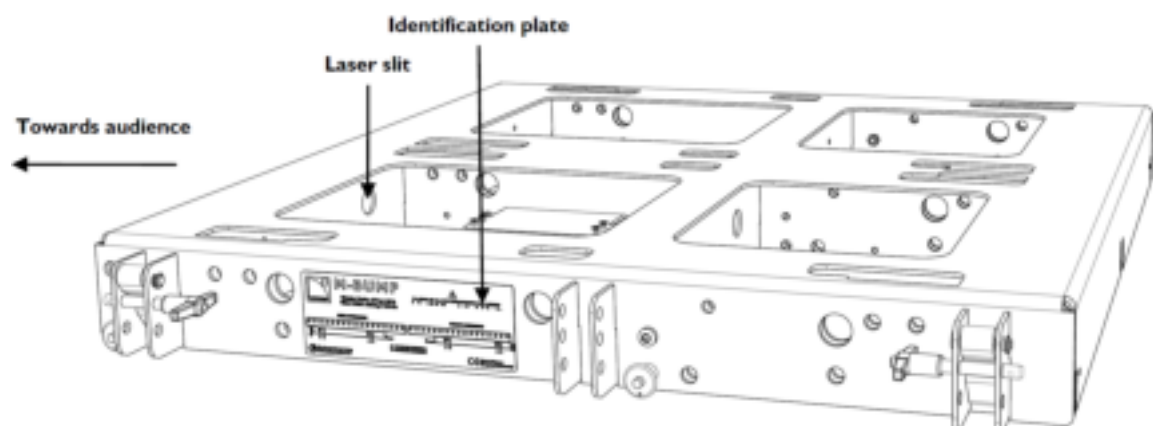

2. (Optional, see [M-BUMP rigging options](#) (p.194)) Install one or two M-BAR on the M-BUMP as follows (repeat for each M-BAR):
- Remove both T-BLP from the M-BAR.
 - Insert both M-BAR studs face to the desired M-BUMP holes.
 - Secure by inserting both preceding T-BLP through M-BAR studs and M-BUMP holes.

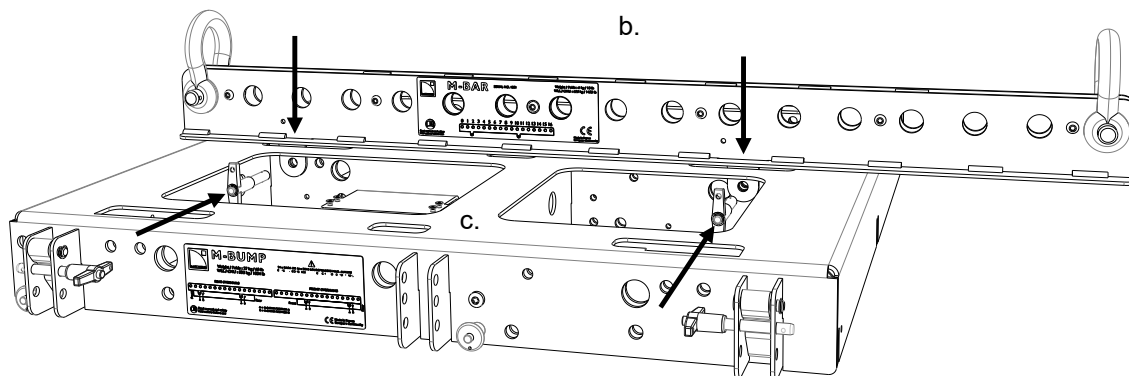

- Attach the shackle(s) to the M-BUMP according to the desired configuration (see [M-BUMP rigging options](#) (p.194)).
- Place a full flight-case at the rigging location and remove the lid. Direct the front face of the 3-Kara II array towards the audience. In the following, the array will be designated as ARRAY#1 and the enclosures as KARA#1 to KARA#3 from top to bottom.
- Check the inter-enclosure connections in ARRAY#1 (repeat for each side):
 - For both front rigging points, verify that the front arm is open and locked to 2 Kara II by 2 R-BLP inserted in yellow link holes.
 - For both rear rigging points, verify that the angle arm cursor is aligned with the 0° angle value and locked to 2 Kara II by 2 R-BLP, the upper one inserted in a yellow link hole and the bottom one inserted into angle hole 0°/2°/4°.



Risk of blocked ball-locking pin.

Be careful not to trap the ball-locking pin tether between the rigging arm and the side handle.

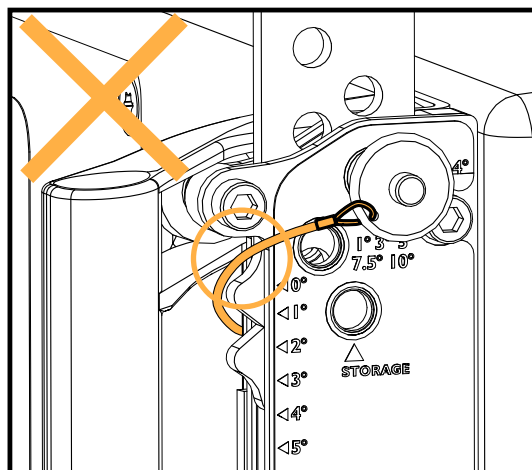

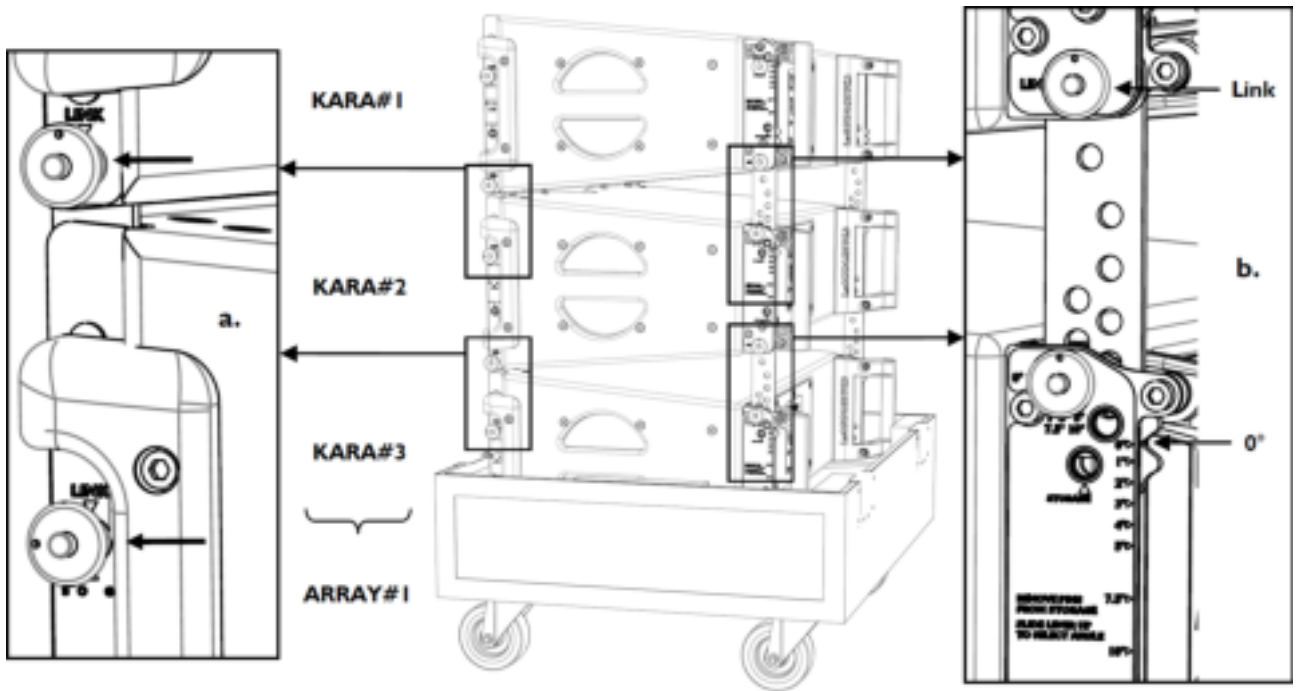

6. On KARA#1, take the 4 arms out as follows (repeat for each side):

- a) Remove the front top R-BLP from storage position, rotate the front arm up, slide it down, and secure by reinserting the R-BLP into the yellow link hole.
- b) Remove the rear top R-BLP, slide the angle arm so as to align the cursor with the 5° angle value, and secure by reinserting the R-BLP into the corresponding angle hole (1°/3°/5°/7.5°/10°).



It is recommended to select the 5° angle on the Kara II intended to be linked to the M-BUMP.

By doing this, the KARA#1 axis is parallel to the M-BUMP, so that a laser secured on M-BUMP can give the site angle of the KARA#1 enclosure.

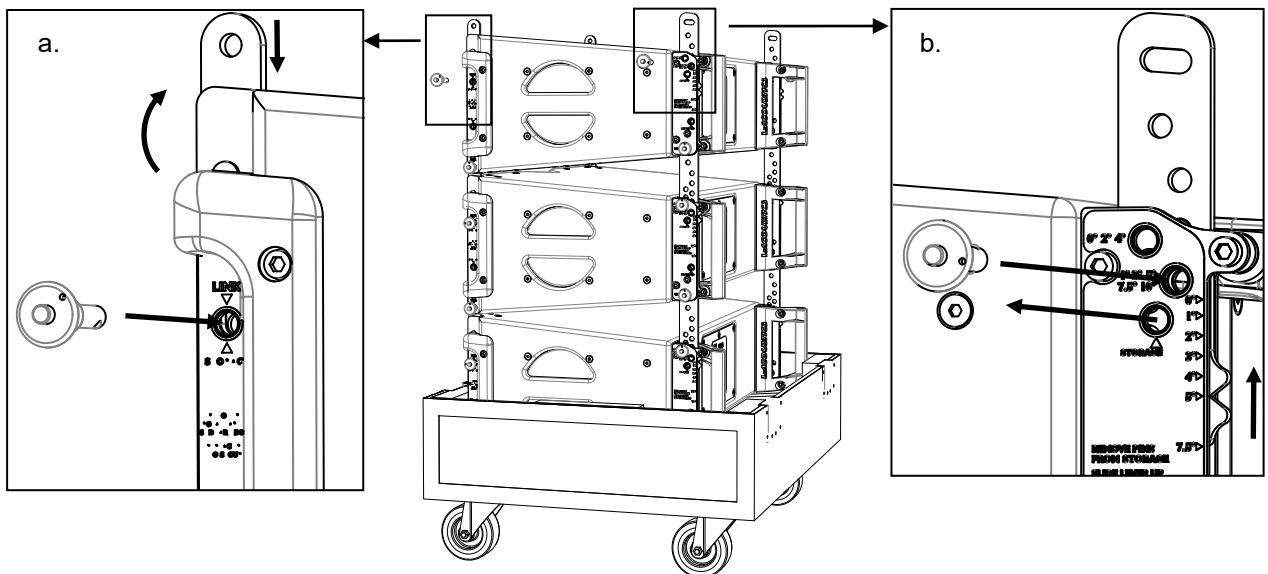

- 7.** Remove the 4 R-BLP from the M-BUMP, put the M-BUMP on ARRAY#1 by aligning the four rigging points, and secure by re-inserting the 4 R-BLP.

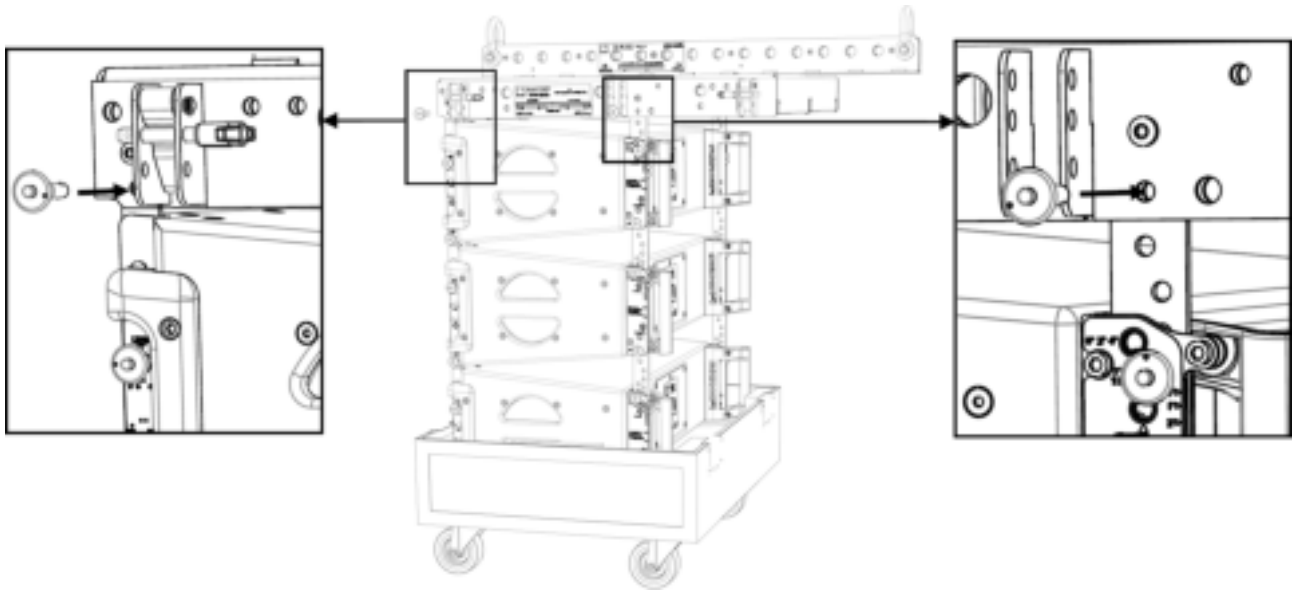

- 8.** Place ARRAY#1 beneath the rigging points, attach the motor hook(s) or stinger(s) to the shackle(s), raise the array to a height for which the angle arms of ARRAY#1 are within comfortable reach, and remove the flight-case from the rigging location.
- 9.** With 2 people working simultaneously on each side of ARRAY#1, set the inter-enclosure angles as follows:
- While grabbing the back handle of KARA#3, remove the rear top R-BLP from KARA#2.
 - Rotate KARA#2 so as to align the cursor of the angle arm with the desired angle value.
 - Secure by re-inserting the R-BLP into the corresponding angle hole ($0^\circ/2^\circ/4^\circ$ or $1^\circ/3^\circ/5^\circ/7.5^\circ/10^\circ$).
 - Repeat the procedure for KARA#3.

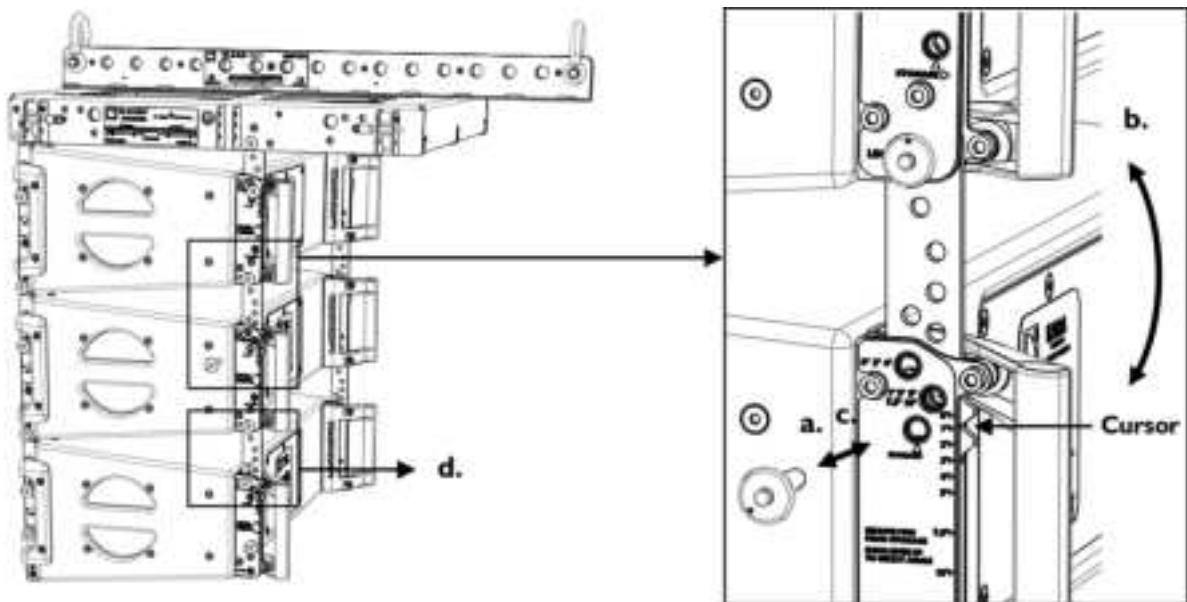

- 10.** Place another full flight-case at the rigging location and remove the lid. Direct the front face of the 3-Kara II array towards the audience. In the following, the array will be designated as ARRAY#2 and the enclosures as KARA#4 to KARA#6 from top to bottom.

11. Check the inter-enclosure connections in ARRAY#2 by applying step 5 (p.55).

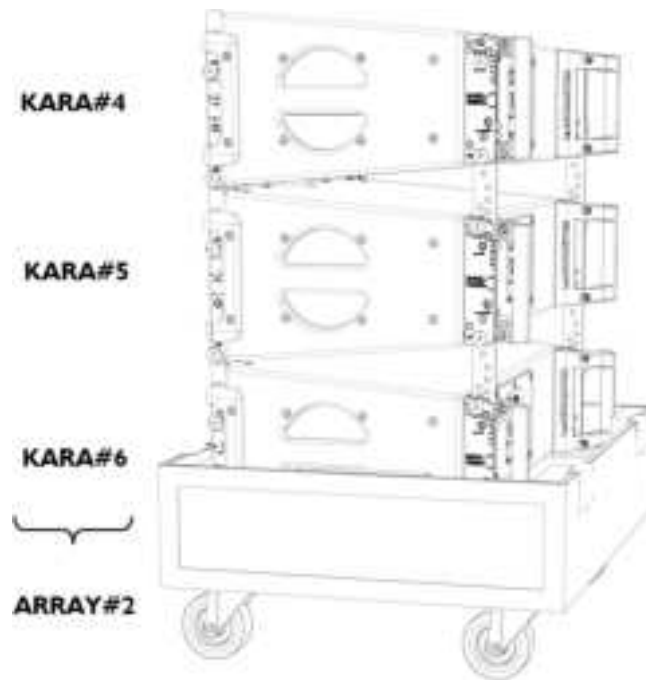

- 12.** On KARA#4, take both front arms out as follows (repeat for each one): remove the front top R-BLP, rotate the front arm up, and slide it down. Do not re-insert the R-BLP.
- 13.** Raise ARRAY#1 slightly higher than the front arms of ARRAY#2 and place ARRAY#2 beneath ARRAY#1.
- 14.** Connect both front rigging points between ARRAY#1 and ARRAY#2 as follows:
 - a) Slide both KARA#4 front arms up and align them with the KARA#3 front bottom rigging points.
 - b) On KARA#3, remove both front bottom R-BLP from the storage holes and re-insert them into the bottom yellow link holes to secure the front arms to KARA#3.
 - c) Lower the array until the front corners of KARA#3 and 4 are in contact (front arms kept vertical).
 - d) Secure the front arms on KARA#4 by inserting both top R-BLP into the top yellow link holes.

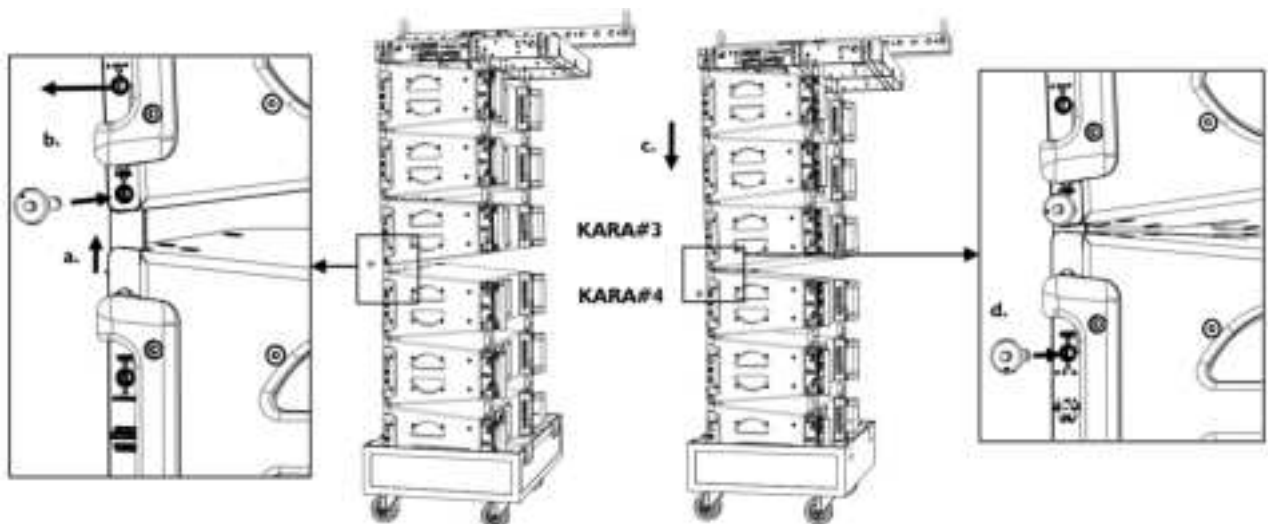

- 15.** Raise the array to a height for which the angle arms of ARRAY#2 are within comfortable reach and remove the flight-case from the rigging location.
- 16.** With 2 people working simultaneously on each side of the array, connect both rear rigging points between ARRAY#1 and ARRAY#2 as follows:
 - a) Remove the KARA#4 rear top R-BLP from its storage position, slide the angle arm so as to align the cursor with the desired angle value, and secure by re-inserting the R-BLP into the corresponding angle hole (0°/2°/4° or 1°/3°/5°/7.5°/10°).
 - b) While grabbing the back handle of KARA#6, rotate ARRAY#2 so as to align the KARA#3 and KARA#4 rear rigging points.
 - c) Link both rigging points by removing the KARA#3 rear bottom R-BLP from its storage position and reinserting it into the yellow link hole.

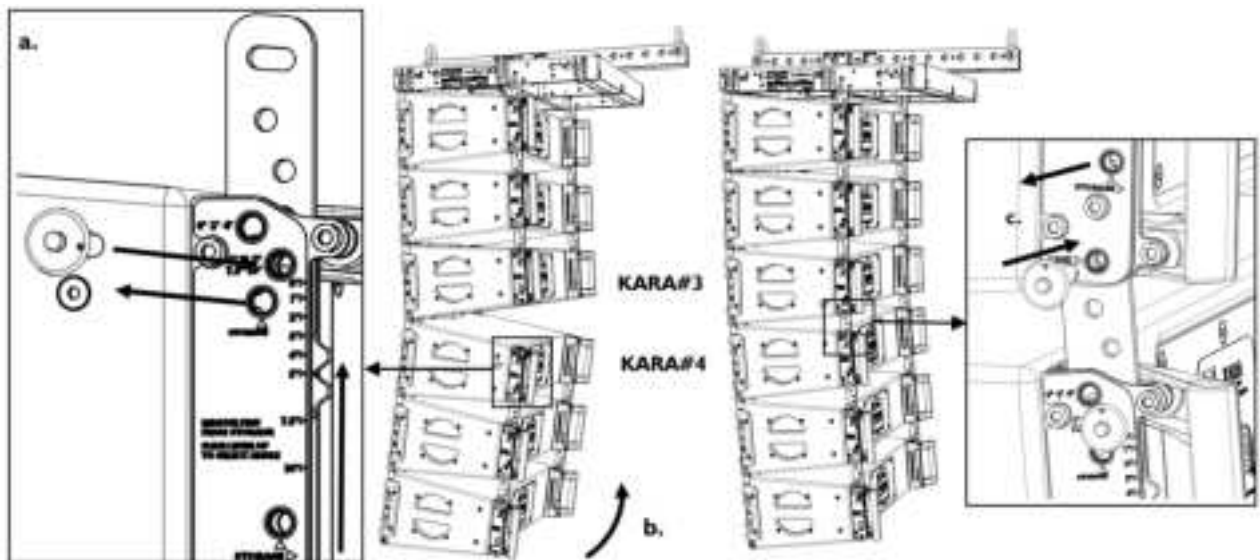

17. Set the inter-enclosure angles in ARRAY#2 by applying step 9 (p.57).
18. Repeat steps 10 (p.57) to 17 until all Kara II enclosures composing the array are rigged.



19. (Optional, for pullback configuration) Attach a KARA-PULLBACK accessory to the bottom Kara II as follows: insert the KARA-PULLBACK studs into the Kara II rigging points (long studs at the back), remove the 4 bottom RBLP from the

Kara II and secure by re-inserting them into the bottom yellow link holes. Attach the hook or stinger of an additional motor to the KARA-PULLBACK shackle.



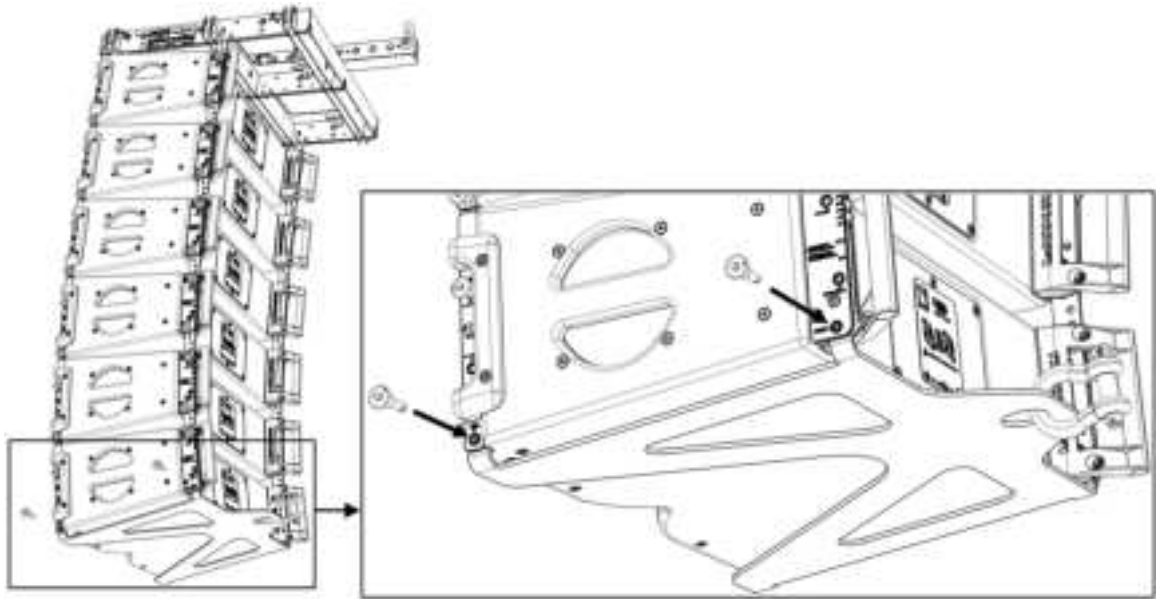

Refer to [KARA-PULLBACK setup safety limits](#) (p.196).



- 20.** Raise the array to the desired height and adjust the site angle (see [M-BUMP site angle setting](#) (p.195)).
- 21.** Secure the M-BUMP to the main rigging structure using two safety slings (not included).

Array removal

About this task

-  All along the procedure:
Strictly follow the sequence of the successive steps.
Systematically verify that each BLP is fully inserted.
-  For clarity purposes the loudspeaker cable removal procedure will not be described.
The loudspeaker cables will not be represented on the figures.

Procedure

1. Remove both safety slings from the M-BUMP.
2. Lower the array to a height for which the angle arms of the bottom ARRAY (ARRAY#2 for example) are within comfortable reach.
3. (Optional, for pullback configuration) Remove the KARA-PULLBACK accessory as follows: lower the pullback chain so as to release tension, remove the motor hook or stinger from the shackle, while holding the KARA-PULLBACK remove the 4 bottom R-BLP from the bottom Kara II, re-insert them into the bottom storage holes, and remove the KARA-PULLBACK.
4. With 2 people working simultaneously on each side of ARRAY#2, set the inter-enclosure angles to 0° as follows:
 - a) While grabbing the back handle of KARA#6, remove the rear top R-BLP of KARA#5.
 - b) Rotate KARA#5 so as to align the cursor of the angle arm with the 0° angle value.
 - c) Secure by re-inserting the R-BLP into angle hole 0°/2°/4°.
 - d) Repeat the procedure for KARA#6.

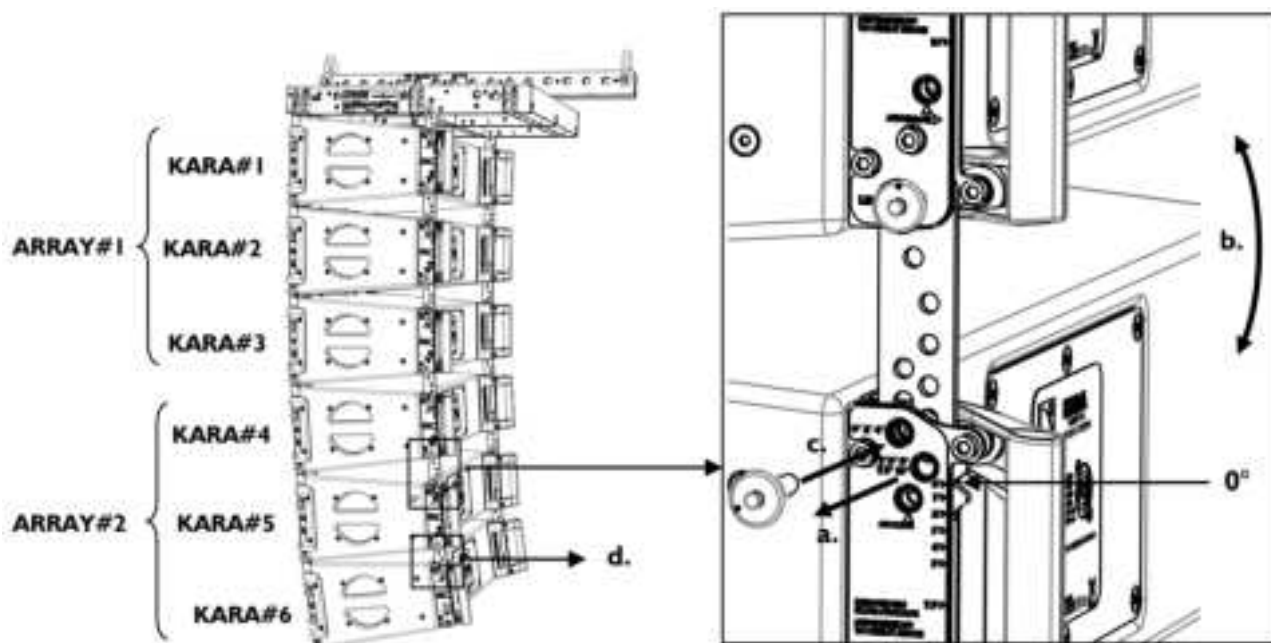

5. Place an empty Kara II flight-case at the rigging location, remove the lid, and put the tray beneath ARRAY#2.

 Pay attention to the tray position: both wedges must slope upwards from front to rear (refer to [Flight-case](#) (p.30)).

6. Lower the array slightly higher than the tray.

7. With two people working simultaneously on each side of the array, remove both rear rigging points between ARRAY#1 and ARRAY#2 as follows:
 - a) While grabbing the back handle of KARA#5, remove the rear bottom link R-BLP from KARA#3 and re-insert it into the bottom storage hole.
 - b) Rotate ARRAY#2 downwards and place the rear corners into the tray while still suspended from the front rigging points.
 - c) Remove the rear top angle R-BLP from KARA#4, slide the angle arm so as to align the cursor with the storage position, and re-insert the R-BLP into the top storage hole.

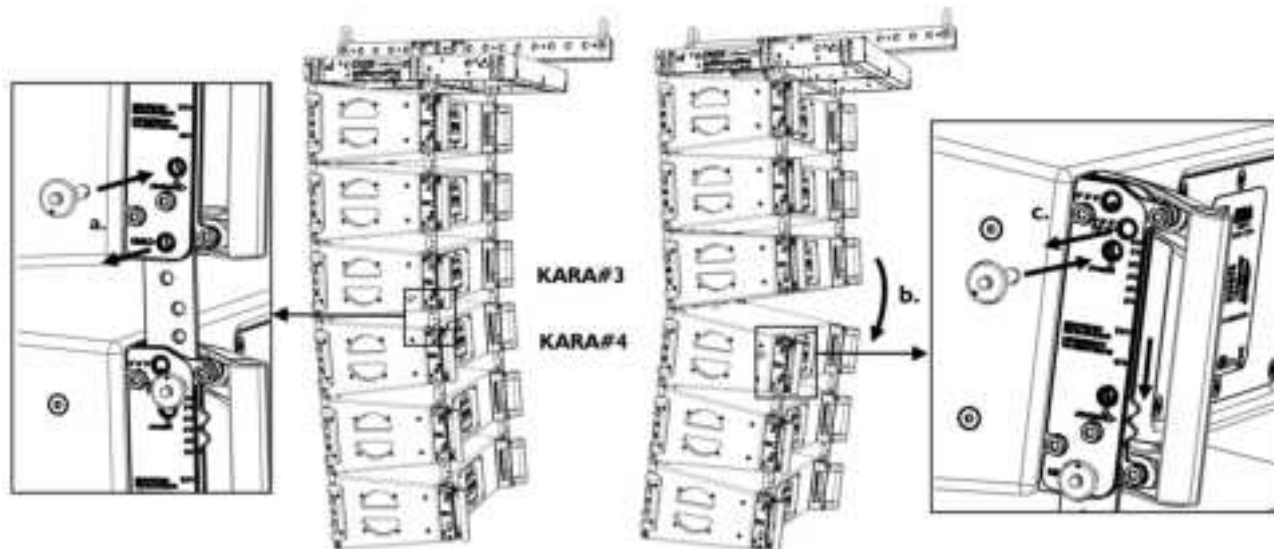

8. Lower the array until ARRAY#2 rests in the tray and the front rigging points between ARRAY#2 and ARRAY#1 are in contact.
9. Remove the front rigging points between ARRAY#1 and ARRAY#2 as follows:
 - a) Remove both KARA#4 front top link R-BLP.
 - b) Slightly raise ARRAY#1.
 - c) Remove both KARA#3 front bottom link R-BLP and re-insert them into the bottom storage holes.
 - d) Rotate both KARA#4 front arms down and re-insert both R-BLP into the top storage holes.

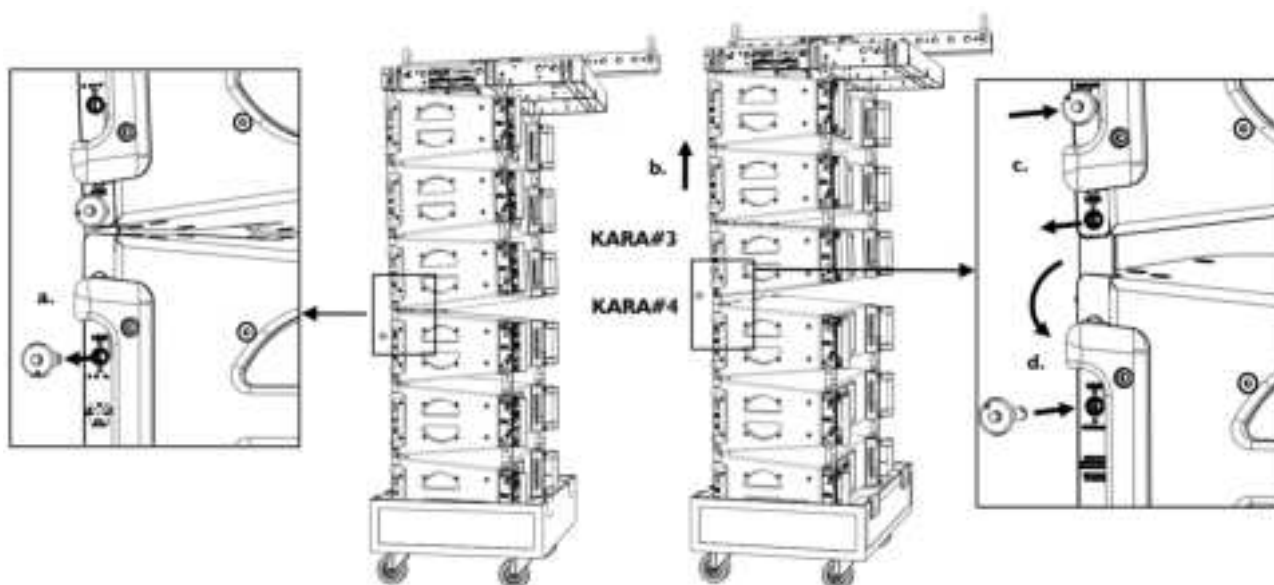

10. Push ARRAY#2 away from the rigging location and put the flight-case lid on.
11. Repeat steps 2 (p.61) to 10 to remove the ARRAYs just until ARRAY#1 is remaining attached to the M-BUMP.
12. Lower the array to a height for which the angle arms of ARRAY#1 are within comfortable reach and set the angles to 0° by applying step 4 (p.61).

13. Place another empty flight-case at the rigging location, remove the lid, and put the tray beneath ARRAY#1.

! Pay attention to the tray position: both wedges must slope upwards from front to rear (refer to [Flight-case](#) (p.30)).

14. Lower ARRAY#1 into the tray. Lower the motor chain(s) so as to release tension.

15. Remove the motor hook(s) or stinger(s), remove the 4 R-BLP from the M-BUMP, and remove the M-BUMP from ARRAY#1.

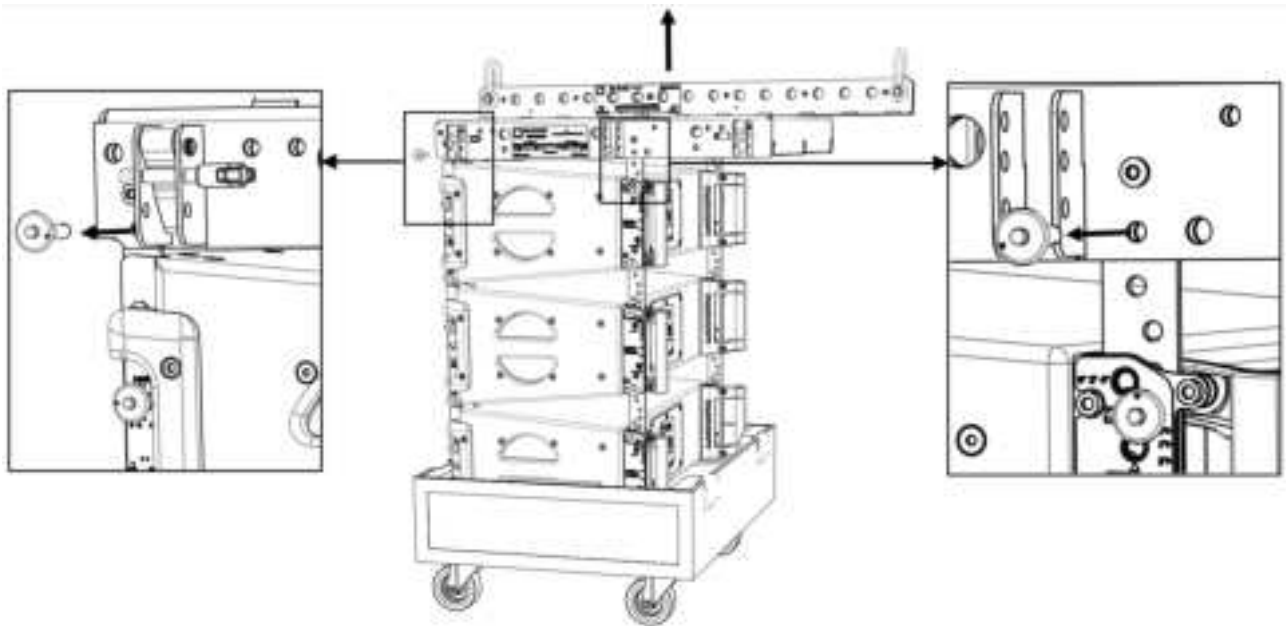

16. Set ARRAY#1 for transport as follows:

- a) On each side of KARA#1, remove the front top link R-BLP, slide the front arm up, rotate down, and secure by re-inserting the R-BLP into the top storage hole.
- b) On each side of the KARA#1, remove the rear top angle R-BLP, slide the angle arm so as to align the cursor with the storage position, and secure by re-inserting the R-BLP into the top storage hole.
- c) Put the flight-case lid on.

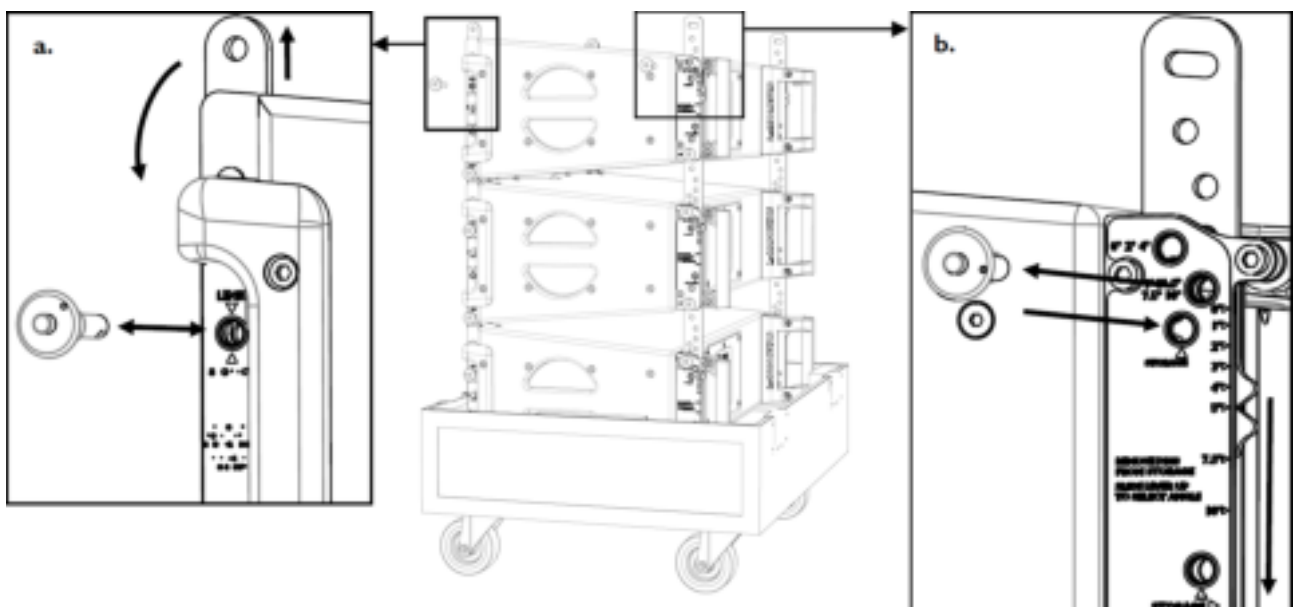

17. Set the M-BUMP for transport as follows:

- a) Re-insert the 4 R-BLP in their storage locations.
- b) Remove each M-BAR as follows: remove both T-BLP from the M-BAR studs, remove the M-BAR, and re-insert both T-BLP in their storage locations.

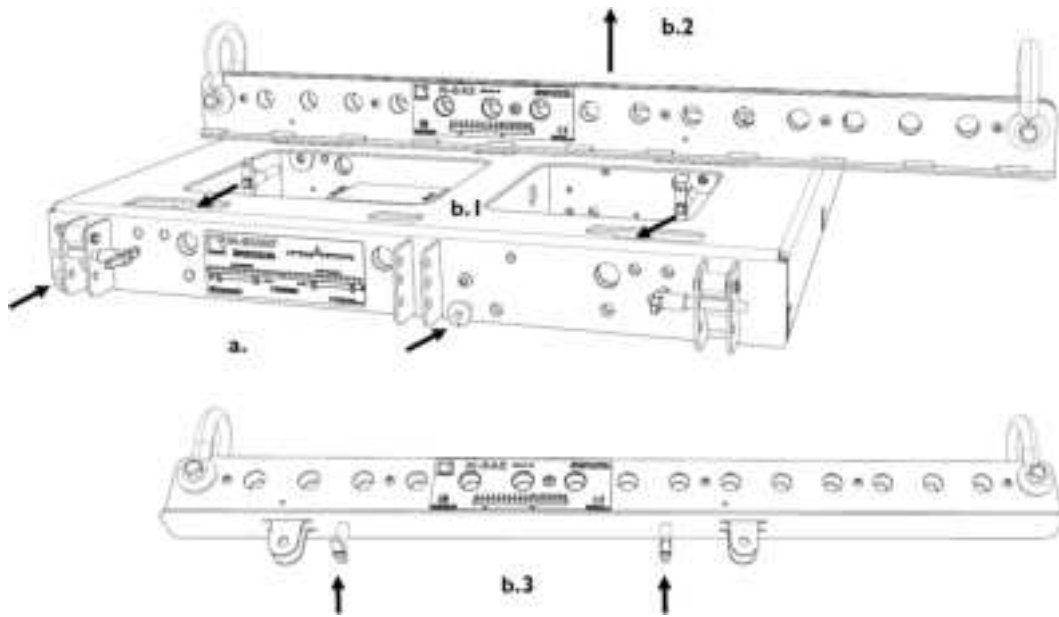

Using KARA-MINIBU

Modeling and safety

Any loudspeaker assembly must be modeled before installation so as to ensure acoustical and mechanical conformity. This can be done using L-Acoustics [Soundvision Software](#) which will assist the user to:

- Determine the number of required Kara II enclosures.
- Calculate the KARA-MINIBU site angle and the inter-enclosure angles.
- Check the mechanical conformity of the loudspeaker assembly.

 The KARA-MINIBU can nominally fly an array of up to 6 Kara II along with all loudspeaker cables (refer to [Mechanical safety](#) (p.31)). However, this maximum number can decrease in line with the array curvature. Always refer to the mechanical data and warning indications provided in [Soundvision Software](#) (**Mechanical Data** section) to verify the mechanical conformity of the loudspeaker assembly before installation.

The Kara II and KARA-MINIBU fully integrated rigging systems allow assembling the array with no need for any external accessory.

The following first procedure describes how to fly a vertical Kara II array under a KARA-MINIBU. It is recommended to assemble the Kara II by successively adding arrays of 3 enclosures (called ARRAY#1 and ARRAY#2 in the order of appearance in the procedure).

The second procedure describes how to disassemble the array.

Array mounting

About this task

 All along the procedure:
 Strictly follow the sequence of the successive steps.
 Systematically verify that each BLP is fully inserted.
 Systematically verify that the bolt is fully screwed in on each shackle.

 For clarity purposes the loudspeaker cabling procedure will not be described.
 The loudspeaker cables will not be represented on the figures.
 Use a strain relief to avoid mechanical stress at the connector locations due to cable weight.
 The motor hooks or stingers will not be represented on the figures.

Procedure

1. Bring a full Kara II flight-case to the rigging location and remove the lid. Direct the front face of the Kara II array towards the audience. In the following, the array will be designated as ARRAY#1 and the enclosures as KARA#1 to KARA#3 from top to bottom.

2. Check the inter-enclosure attachments in ARRAY#1 as follows (repeat on both sides of the array):
 - a) Verify that each front arm (x2) is open and secured to the **link** holes of two Kara II by two R-BLP.

i A **link** hole is indicated by a yellow circle.

- b) Verify that each angle arm (x2) has the cursor aligned with the 0° angle label and is secured to two Kara II by two R-BLP, the top one being inserted into the **link** hole and the bottom one into angle hole 0°/2°/4°.

! **Risk of blocked ball-locking pin.**
Be careful not to trap the ball-locking pin tether between the rigging arm and the side handle.

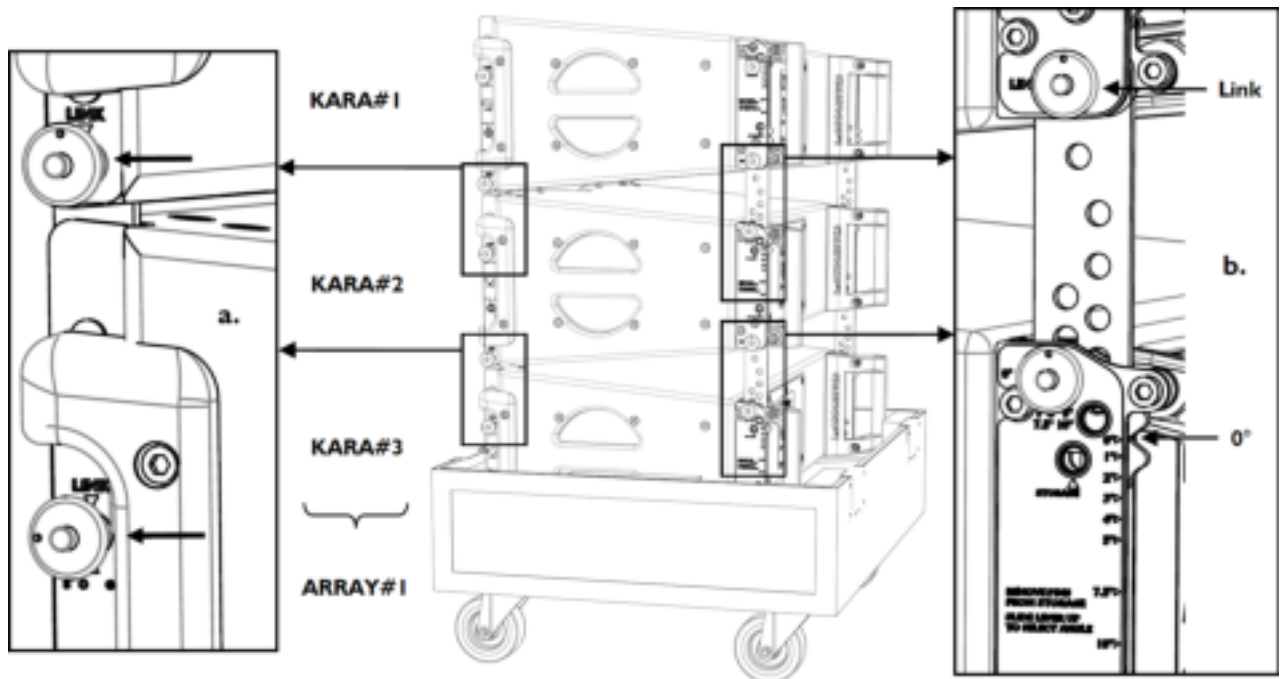
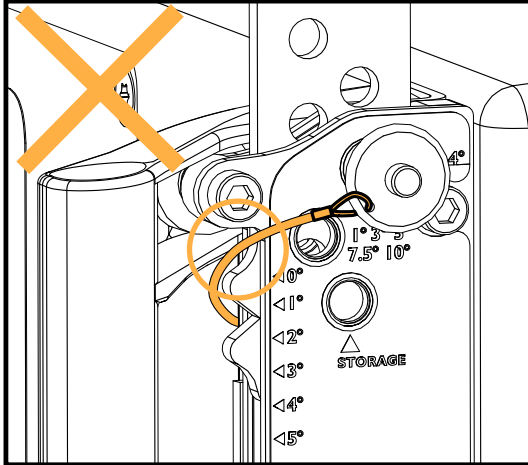

3. Open the four KARA#1 arms as follows (repeat on both sides of the enclosure):
 - a) Remove the front top R-BLP from its **storage** hole, rotate the front arm up, slide it down, and lock it in place by re-inserting the R-BLP into its **link** hole.

i The front top **storage** and **link** holes are the same.

- b) Remove the rear top R-BLP from its **storage** hole, slide the angle arm so as to align the cursor with angle label 5°, and lock it in place by re-inserting the R-BLP into angle hole 1°/3°/5°/7.5°/10°.

- i** It is recommended to select the 5° angle on the Kara II intended to be attached to the KARA-MINIBU. By doing this, the KARA#1 axis is parallel to the KARA-MINIBU, so that a laser secured on KARA-MINIBU can give the site angle of the KARA#1 enclosure.

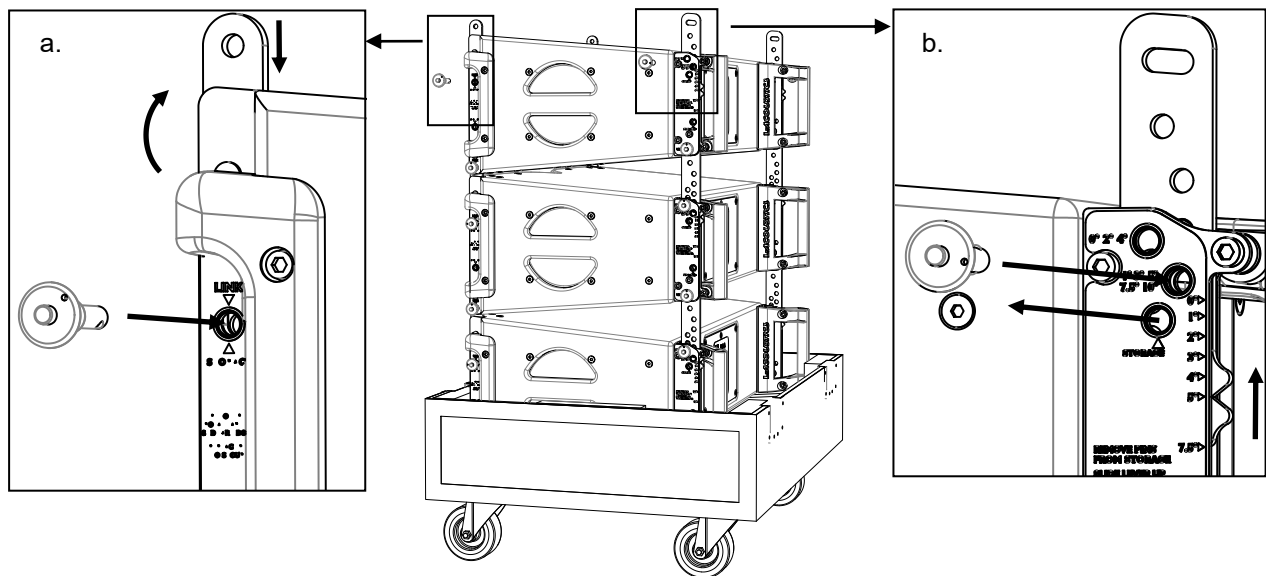

4. Attach a KARA-MINIBU to KARA#1 as follows:

- Remove the four R-BLP from the KARA-MINIBU.
- Turn the KARA-MINIBU so that the text of the identification plate is readable and the laser plate is placed at the front (towards audience).
- While keeping this orientation, align the four link points of KARA-MINIBU with the four arms of KARA#1 and secure each pair together by re-inserting the four R-BLP into the same holes (insert both rear R-BLP first).

- i** If KARA-MINIBUEX rigging plates are already mounted to the KARA-MINIBU (see Array mounting, step 1 (p.86)), it is not necessary to remove them: the KARA-MINIBU/KARA-MINIBUEX rigging structure can also be used in place of the KARA-MINIBU.

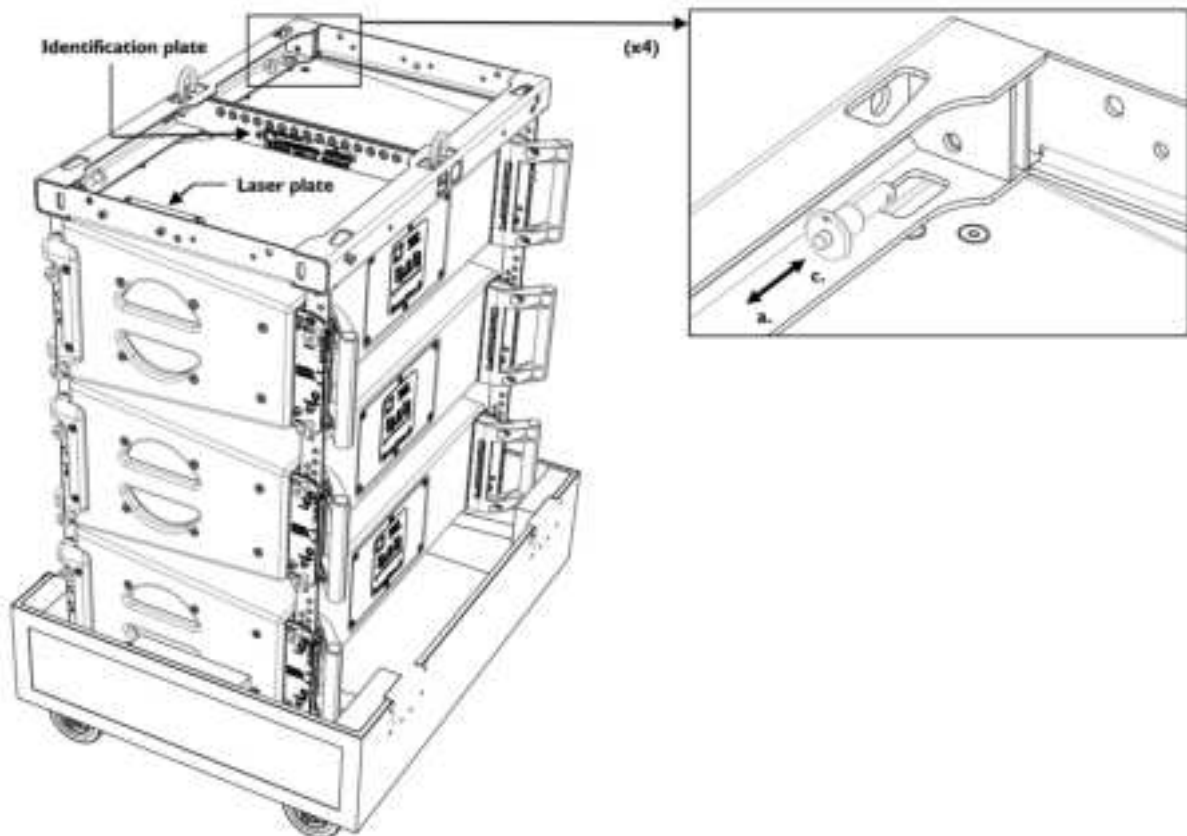

5. Attach the shackle(s) to the KARA-MINIBU according to the chosen configuration (see [KARA-MINIBU rigging options](#) (p.197)).

i If the array is intended to be flown in pullback configuration, attach a single shackle to the rear pullback hole (see [KARA-MINIBU](#) (p.24)).

6. Place ARRAY#1 beneath the rigging points and attach the motor hook(s) or stinger(s) to the shackle(s).
7. Raise the array to a height for which the angle arms of ARRAY#1 are within comfortable reach and remove the flight-case from the rigging location.
8. With two people working simultaneously on each side of ARRAY#1, set the inter-enclosure angles as follows:
 - a) While grabbing the back handle of KARA#3, remove the KARA#2 rear top R-BLP from angle hole 0°/2°/4°.
 - b) Rotate KARA#2 so as to align the angle arm cursor with the chosen angle label.
 - c) Lock KARA#2 in place by re-inserting the R-BLP into the corresponding angle hole (0°/2°/4° or 1°/3°/5°/7.5°/10°).
 - d) Repeat the procedure for KARA#3.

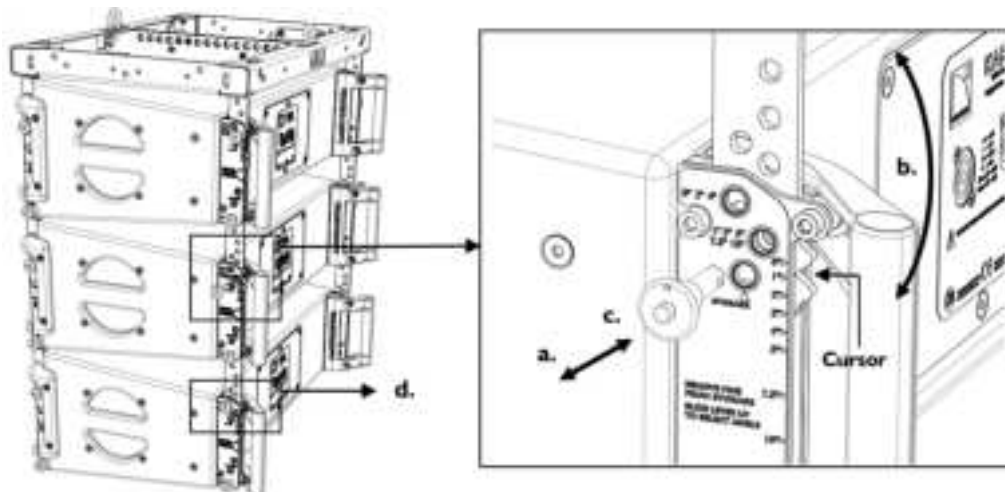

9. Bring another full Kara II flight-case to the rigging location and remove the lid. Direct the front face of the Kara II array towards the audience. In the following, the array will be designated as ARRAY#2 and the enclosures as KARA#4 to KARA#6 from top to bottom.
10. Check the inter-enclosure attachments in ARRAY#2 by applying step 2 (p.66).

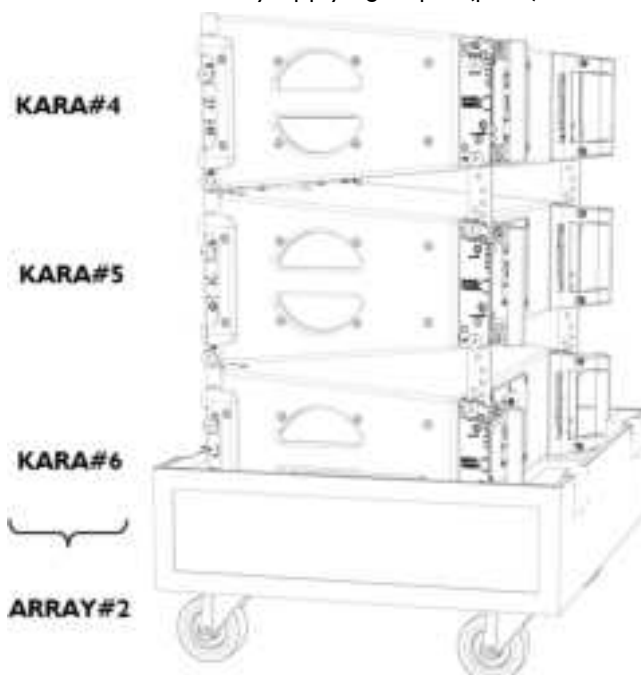

11. On KARA#4, open both front arms as follows (repeat for each one): remove the front top R-BLP from its **storage** hole, rotate the front arm up, and slide it down. Do not re-insert the R-BLP.
12. Raise ARRAY#1 slightly higher than the front arms of ARRAY#2 and place ARRAY#2 beneath ARRAY#1.
13. Secure the front link points between ARRAY#1 and ARRAY#2 as follows:
 - a) Slide each KARA#4 front arm up and align it with the KARA#3 front bottom link point.

- b) Secure each KARA#4 front arm to KARA#3 by removing the KARA#3 front bottom R-BLP from its **storage** hole and re-inserting it into its link hole.
- c) Lower the array until KARA#3 and KARA#4 front corners are in contact (keep the front arms vertical).
- d) Secure each front arm to KARA#4 by inserting the KARA#4 front top R-BLP into its **link** hole.

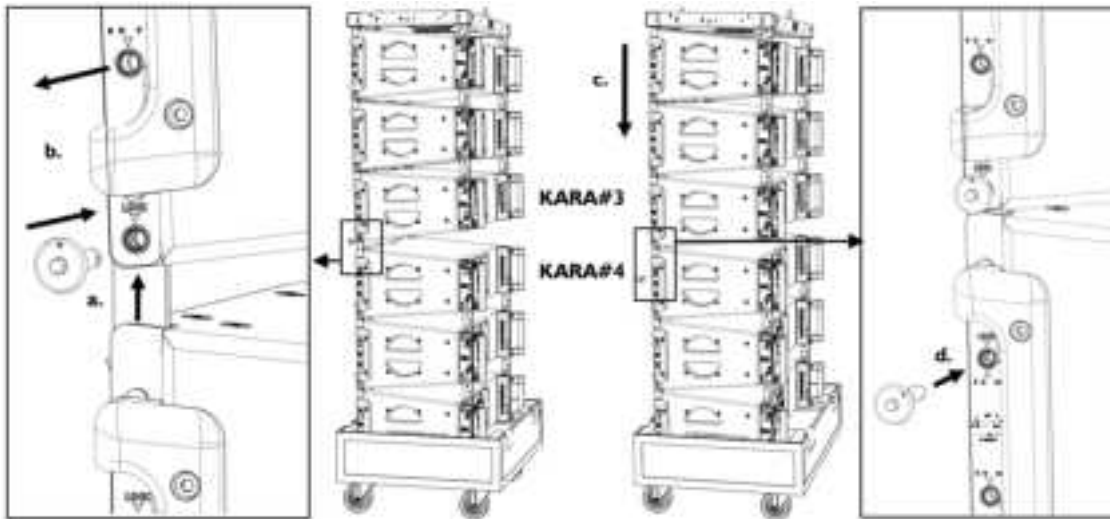

14. Raise the array to a height for which the angle arms of ARRAY#2 are within comfortable reach and remove the flight case from the rigging location.
15. With 2 people working simultaneously on each side of the array, secure the rear link points between ARRAY#1 and ARRAY#2 as follows:
 - a) Remove the KARA#4 rear top R-BLP from its **storage** hole, slide the angle arm so as to align the cursor with the chosen angle label, and lock it in place by re-inserting the R-BLP into the corresponding angle hole ($0^\circ/2^\circ/4^\circ$ or $1^\circ/3^\circ/5^\circ/7.5^\circ/10^\circ$).
 - b) While grabbing the back handle of KARA#6, rotate ARRAY#2 so as to align the KARA#3 and KARA#4 rear link points.
 - c) Lock ARRAY#2 in place by removing the KARA#3 rear bottom R-BLP from its **storage** hole and re-inserting it into its **link** hole.

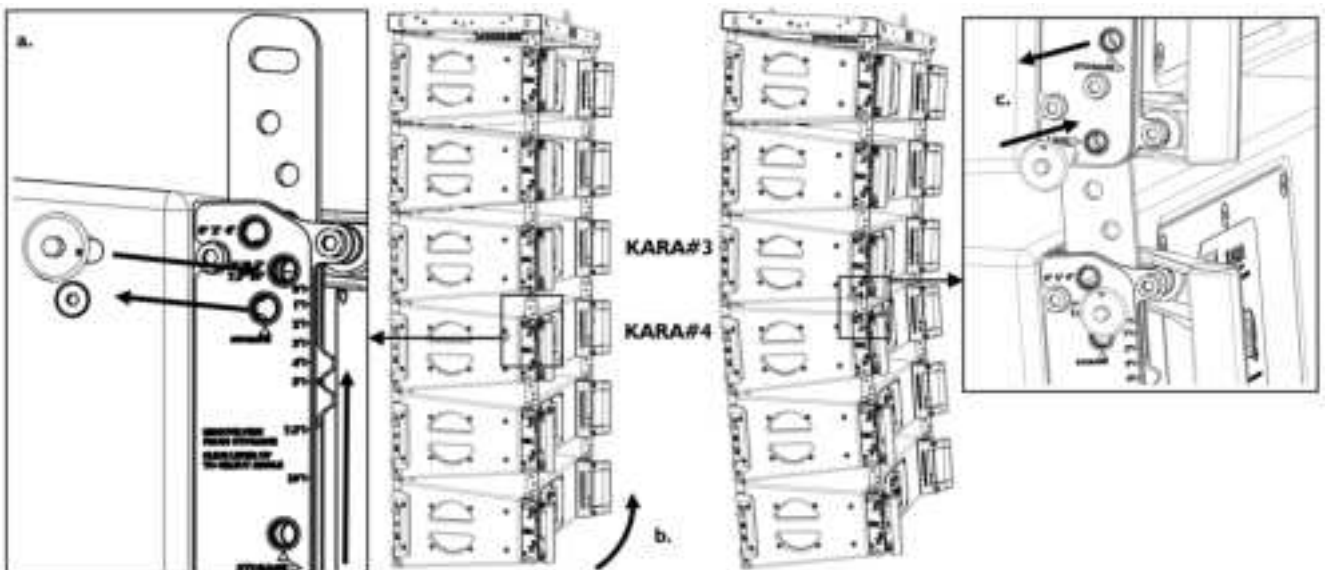

16. Set the inter-enclosure angles in ARRAY#2 by applying step 8 (p.68).

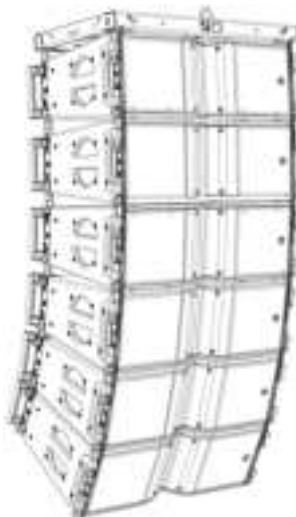

17. If the array is intended to be flown in pullback configuration, attach a KARA-PULLBACK to the bottom Kara II as follows:

- a) Align the KARA-PULLBACK studs with the Kara II link points (long studs at the back).
- b) Remove the four Kara II bottom R-BLP from their **storage** holes and lock the KARA-PULLBACK in place by re-inserting them into their **link** holes.
- c) Attach the hook or stinger of an additional motor to the KARA-PULLBACK shackle.



Refer to [KARA-PULLBACK setup safety limits](#) (p.196).

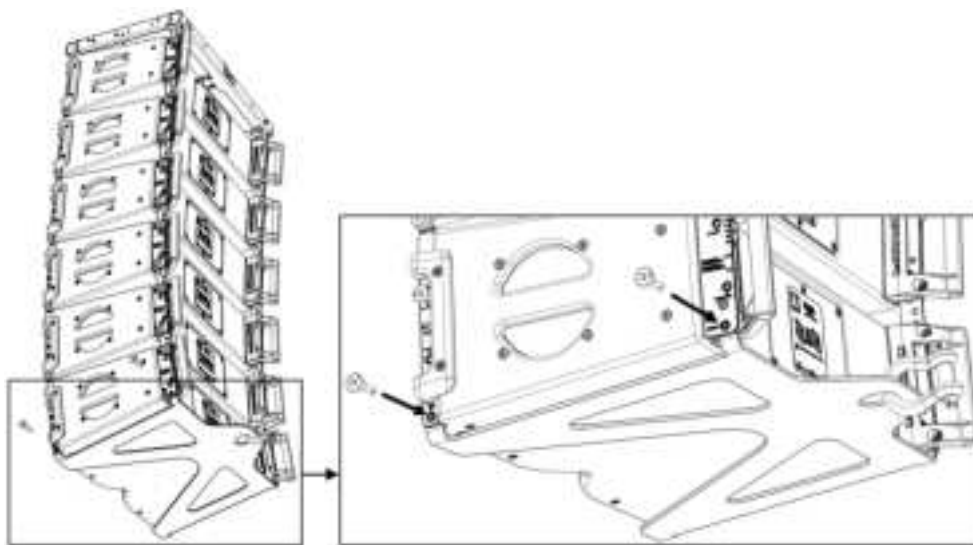



18. Raise the array to the chosen height and adjust the site angle (see [KARA-MINIBU site angle setting](#) (p.198)).

19. Secure the KARA-MINIBU to the main rigging structure by using two safety slings (not included).

Array removal

About this task

-  All along the procedure:
Strictly follow the sequence of the successive steps.
Systematically verify that each BLP is fully inserted.
-  For clarity purposes the loudspeaker cable removal procedure will not be described.
The loudspeaker cables will not be represented on the figures.

Procedure

1. Detach both safety slings from the KARA-MINIBU.
2. Lower the array to a height for which the angle arms of ARRAY#2 are within comfortable reach.
3. If the array to disassemble has been flown in pullback configuration, separate the KARA-PULLBACK from the bottom Kara II as follows:
 - a) Lower the pullback chain so as to release tension and detach the motor hook or stinger from the shackle.
 - b) While holding the KARA-PULLBACK, remove the four Kara II bottom R-BLP from their **link** holes and re-insert them into their **storage** holes.
 - c) Remove the KARA-PULLBACK.
4. With 2 people working simultaneously on each side of ARRAY#2, set the inter-enclosure angles to 0° as follows:
 - a) While grabbing the back handle of KARA#6, remove the KARA#5 rear top R-BLP from its angle hole.
 - b) Rotate KARA#5 so as to align the cursor of the angle arm with angle label 0°.
 - c) Lock KARA#5 in place by re-inserting the R-BLP into angle hole 0°/2°/4°.
 - d) Repeat the procedure for KARA#6.

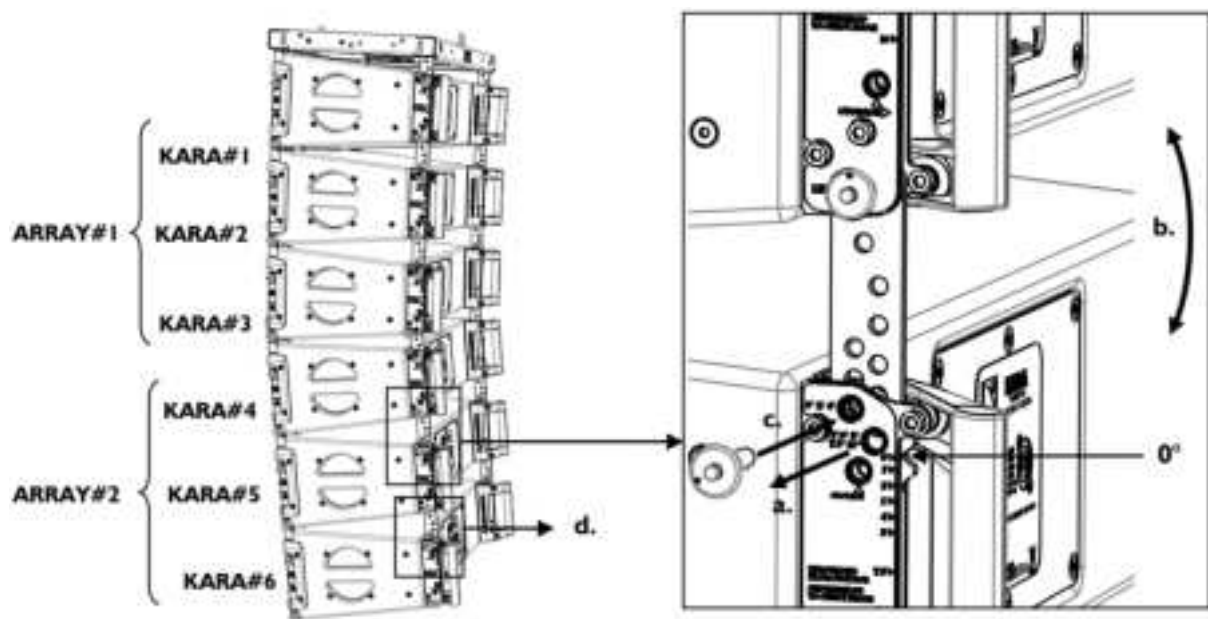

5. Bring an empty Kara II flight-case to the rigging location, remove the lid, and place the tray beneath ARRAY#2.
 -  Pay attention to the tray position: both wedges must slope upwards from front to rear (refer to [Flight-case](#) (p.30)).
6. Lower the array slightly higher than the tray.
7. With 2 people working simultaneously on each side of the array, disconnect the rear link points between ARRAY#1 and ARRAY#2 as follows:
 - a) While grabbing the back handle of KARA#5, remove the KARA#3 rear bottom R-BLP from its **link** hole and re-insert it into its **storage** hole.
 - b) Rotate ARRAY#2 downwards and position the rear corners into the tray while still suspended from the front link points.
 - c) Remove the KARA#4 rear top R-BLP from its angle hole, slide the angle arm so as to align the cursor with the storage label, and re-insert the R-BLP into its **storage** hole.

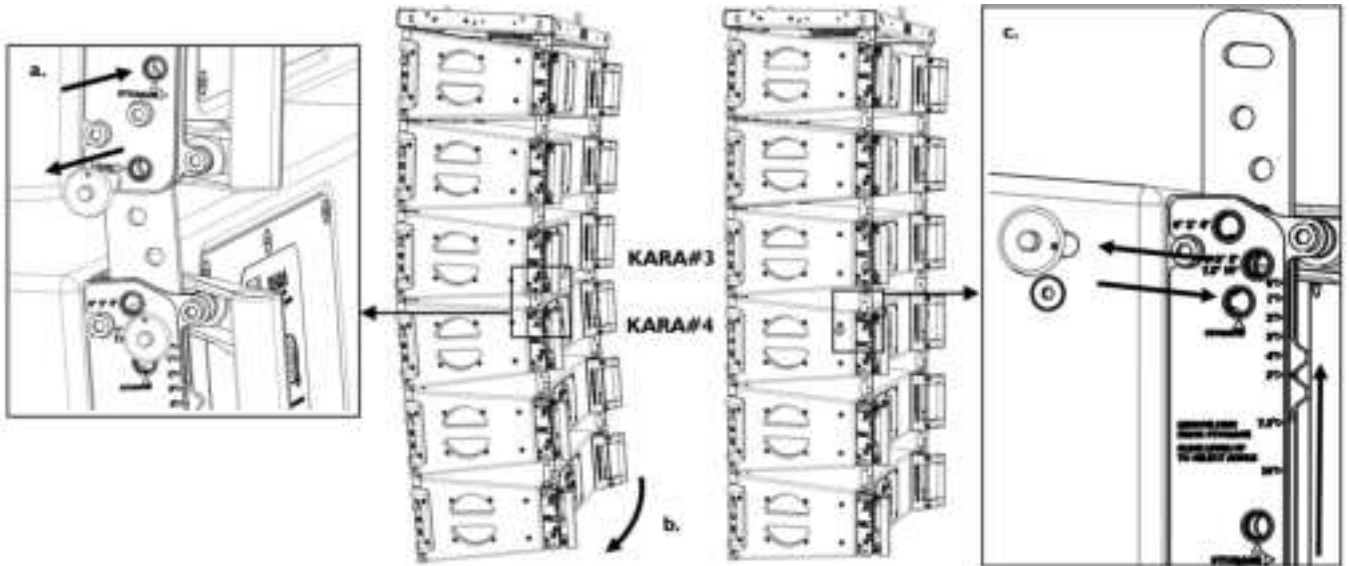

8. Lower the array until ARRAY#2 rests in the tray and the front link points between ARRAY#2 and ARRAY#1 are in contact.
9. Disconnect the front link points between ARRAY#1 and ARRAY#2 as follows:
 - a) Remove both KARA#4 front top R-BLP from their **link** holes.
 - b) Slightly raise ARRAY#1 so that it is no longer in contact with ARRAY#2.
 - c) Remove both KARA#3 front bottom R-BLP from their **link** holes and re-insert them into their **storage** holes.
 - d) Rotate both KARA#4 front arms down and re-insert both front top R-BLP into their **storage** holes.

i The front top **storage** and **link** holes are the same.

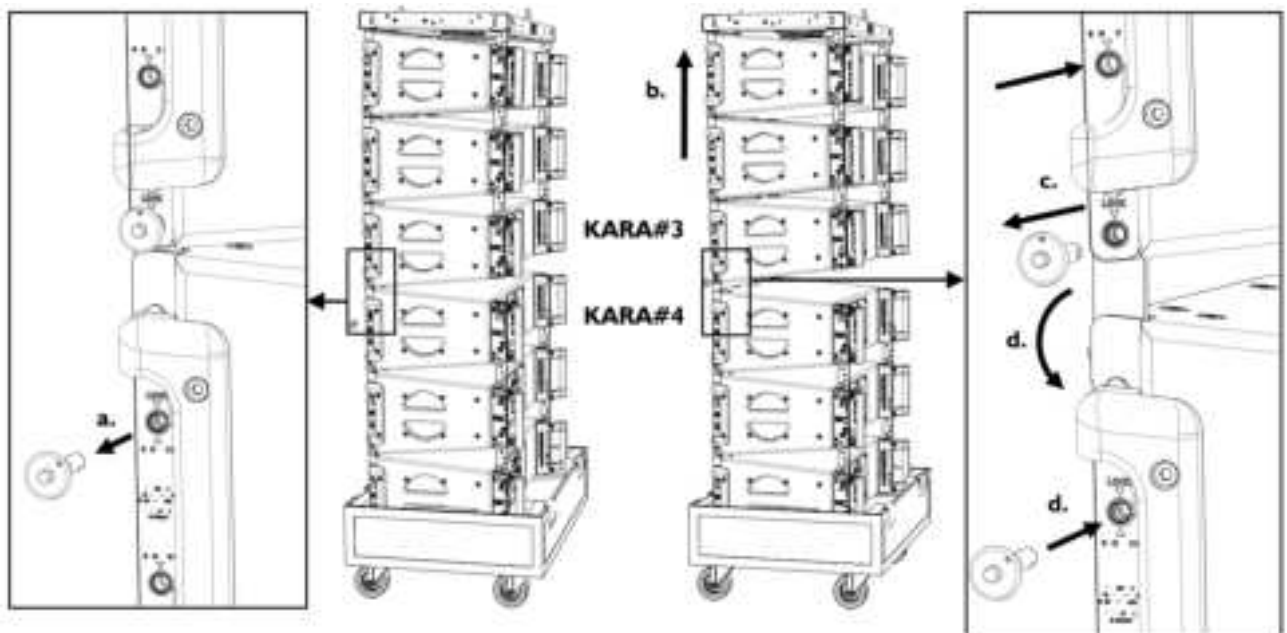

10. Remove ARRAY#2 from the rigging location and attach the lid to the flight-case.
11. Lower the array to a height for which the angle arms of ARRAY#1 are within comfortable reach and set the angles to 0° by applying step 4 (p.71).
12. Bring another empty flight-case to the rigging location, remove the lid, and place the tray beneath ARRAY#1.
 - !** Pay attention to the tray position: both wedges must slope upwards from front to rear (refer to [Flight-case](#) (p.30)).
13. Lower ARRAY#1 into the tray. Lower the motor chain(s) so as to release tension.

14. Remove the KARA-MINIBU from KARA#1 as follows:

- a) Detach the motor hook(s) or stinger(s) from the KARA-MINIBU.
- b) Remove the four R-BLP from the KARA-MINIBU.
- c) Remove the KARA-MINIBU from KARA#1 and re-insert the four R-BLP into the same holes.

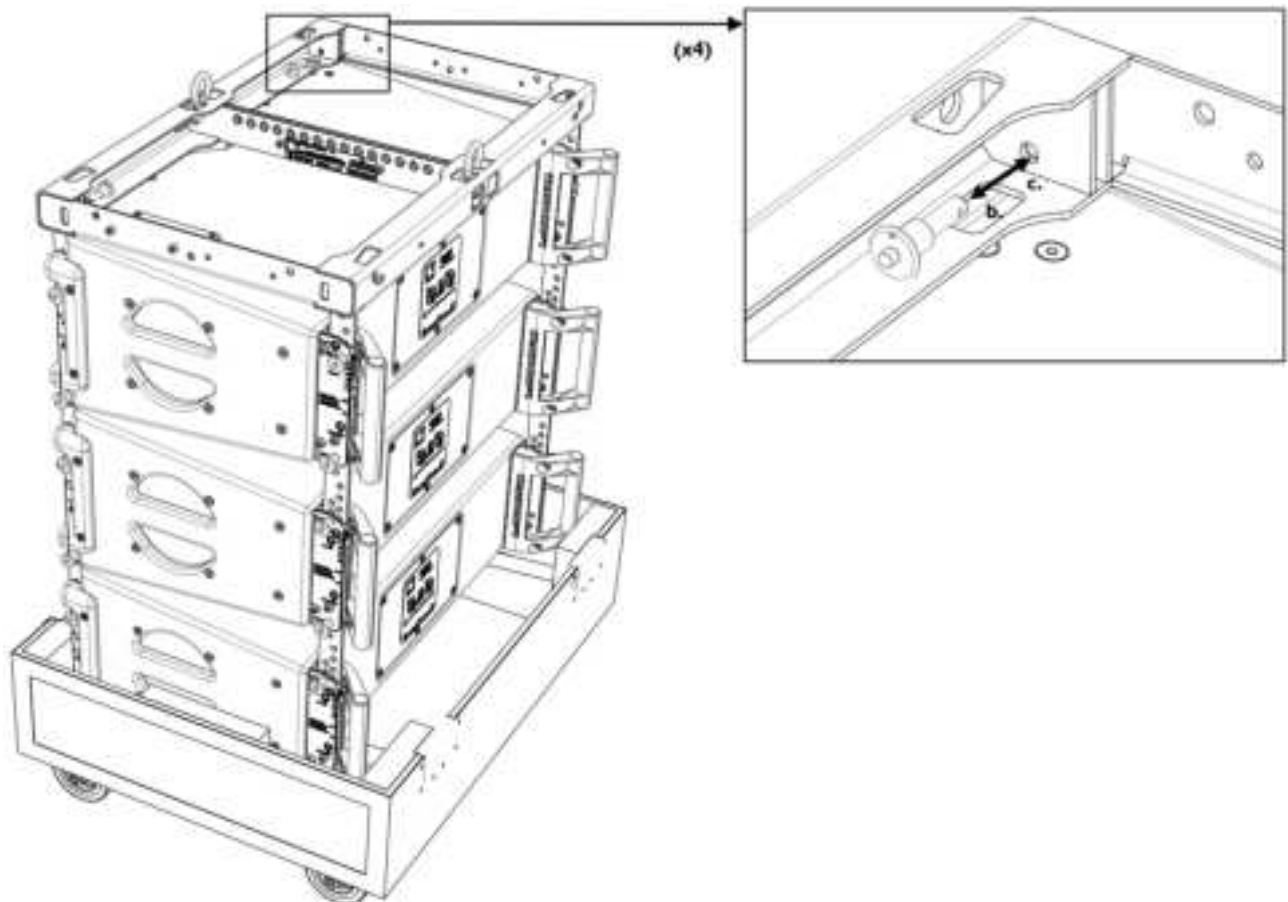

15. Close the four KARA#1 arms as follows (repeat on both sides of the enclosure):

- a) Remove the front top R-BLP from its **link** hole, slide the front arm up, rotate it down, and lock it in place by re-inserting the R-BLP into its **storage** hole.
- b) Remove the rear top R-BLP from its angle hole, slide the angle arm so as to align the cursor with the storage label, and lock it in place by re-inserting the R-BLP into its **storage** hole.

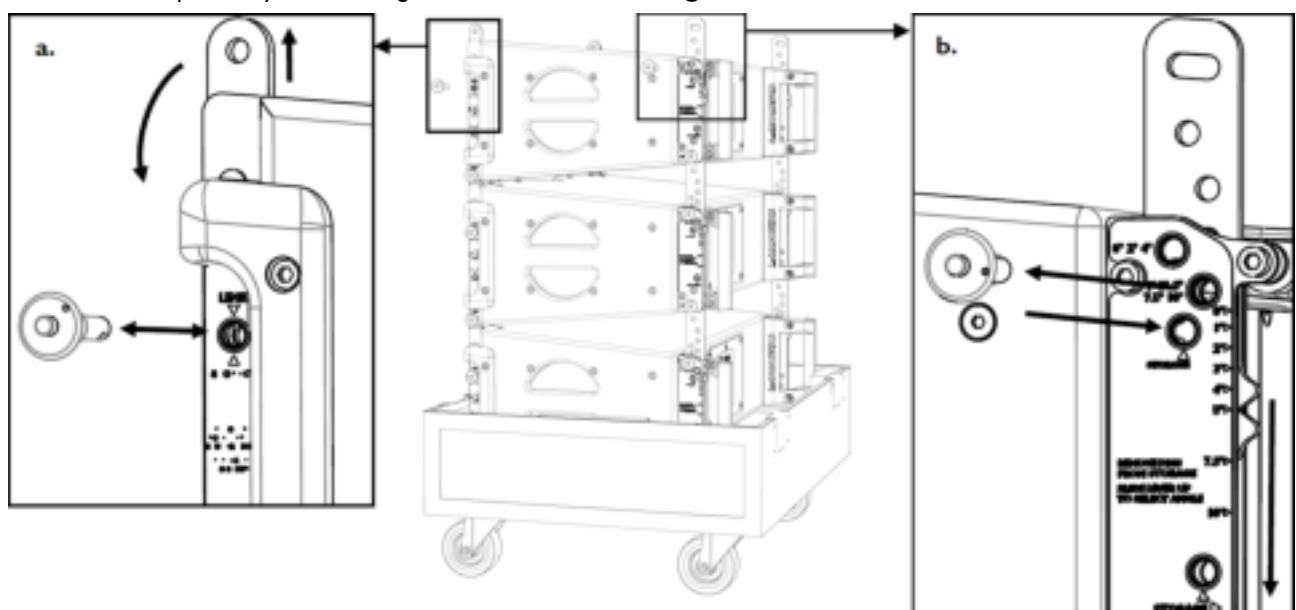

16. Attach the lid to the flight-case.

Flying an SB18/Kara II mixed array or an SB18 standalone array

Using M-BUMP

Modeling and safety

Any system must be modeled before installation so as to ensure acoustical and mechanical conformity. This can be done using L-Acoustics [Soundvision Software](#) which will assist the user to:

- Determine the number of required Kara II enclosures.
- Calculate the array site angle and the inter-enclosure angles.
- Check the mechanical conformity of the system.

! The M-BUMP can nominally fly an array of up to 4 SB18/12 Kara II or 16 SB18 along with all loudspeakers cables (refer to [Mechanical safety](#) (p.31)). However, this maximum number can decrease in line with the array curvature and/or the acoustic coupling conditions (depending on the selected operation mode as described in the Kara II User manual).

ALWAYS refer to the mechanical data and warning indications provided in [Soundvision Software](#) (**Mechanical Data** section) to verify the mechanical conformity of the system before installation.

The Kara II, SB18 and M-BUMP fully integrated rigging systems allow assembling the array with no need for any external accessory.

The following first procedure describes how to fly a vertical SB18/Kara II array using two M-BUMP. According to the array composition, the SB18 enclosures can be rigged one by one or by pairs (as shown in the procedure). It is recommended to rig the Kara II by successively adding arrays of 3 enclosures (called ARRAY#1, ARRAY#2... in the order of appearance in the procedure). The second procedure describes how to disassemble the array.

Array mounting

About this task

! All along the procedure:
Strictly follow the sequence of the successive steps.
Systematically verify that each BLP is fully inserted.
Systematically verify that the bolt is fully screwed in on each shackle.

! For clarity purposes the loudspeaker cabling procedure will not be described.
The loudspeaker cables will not be represented on the figures.
Use a strain relief to avoid mechanical stress at the connector locations due to cable weight.
The motor hooks or stingers will not be represented on the figures.

Procedure

1. Place an M-BUMP at the rigging location. Turn it so that the text of the identification plate is readable and the laser slits are directed towards the audience.

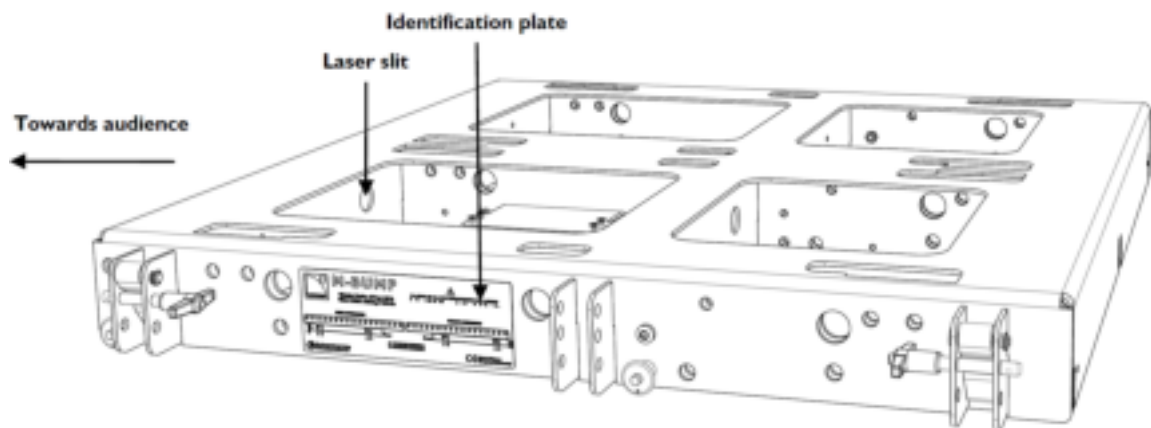

2. (Optional, see [M-BUMP rigging options](#) (p.194)) Install one or two M-BAR on the M-BUMP as follows (repeat for each M-BAR):
- Remove both T-BLP from the M-BAR.
 - Insert both M-BAR studs face to the desired M-BUMP holes.
 - Secure by inserting both preceding T-BLP through M-BAR studs and M-BUMP holes.

i In case of SB18 standalone array rigging, the M-BAR is not useful unless it is intended to modify the distance between the rigging points (see [M-BUMP rigging options](#) (p.194)).

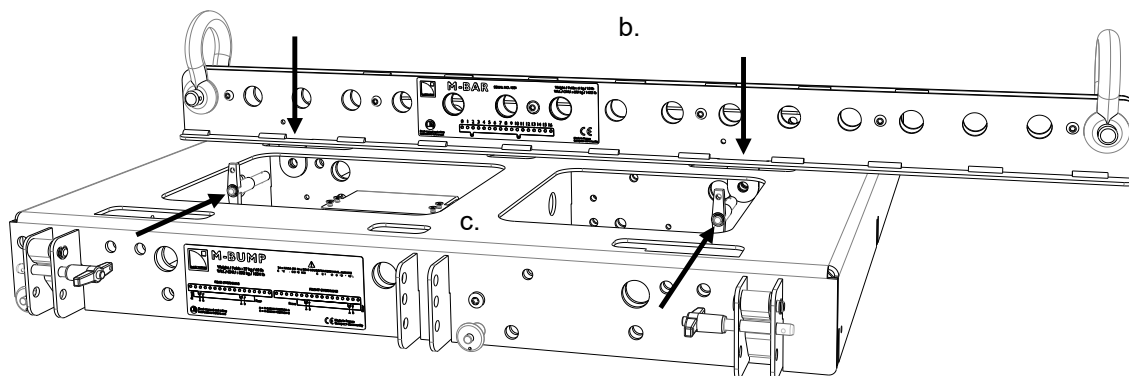

- Attach the shackle(s) to the M-BUMP according to the desired configuration (see [M-BUMP rigging options](#) (p.194)).
- Build a stack composed of two SB18 (hereafter called SB18#1 and SB18#2) at the rigging location as follows:
 - Place two SB18 at the rigging location and remove the dolly boards.
 - Put SB18#1 onto SB18#2 so that the front grills are facing the audience and the logos are placed at the bottom.
 - Attach the four rigging arms of SB18#2 to SB18#1 as follows: disconnect a T-BLP from SB18#2, rotate the rigging arm up, re-connect the T-BLP to the SB18#1 rigging point and the rigging arm ; repeat this procedure until all 4 arms are secured.

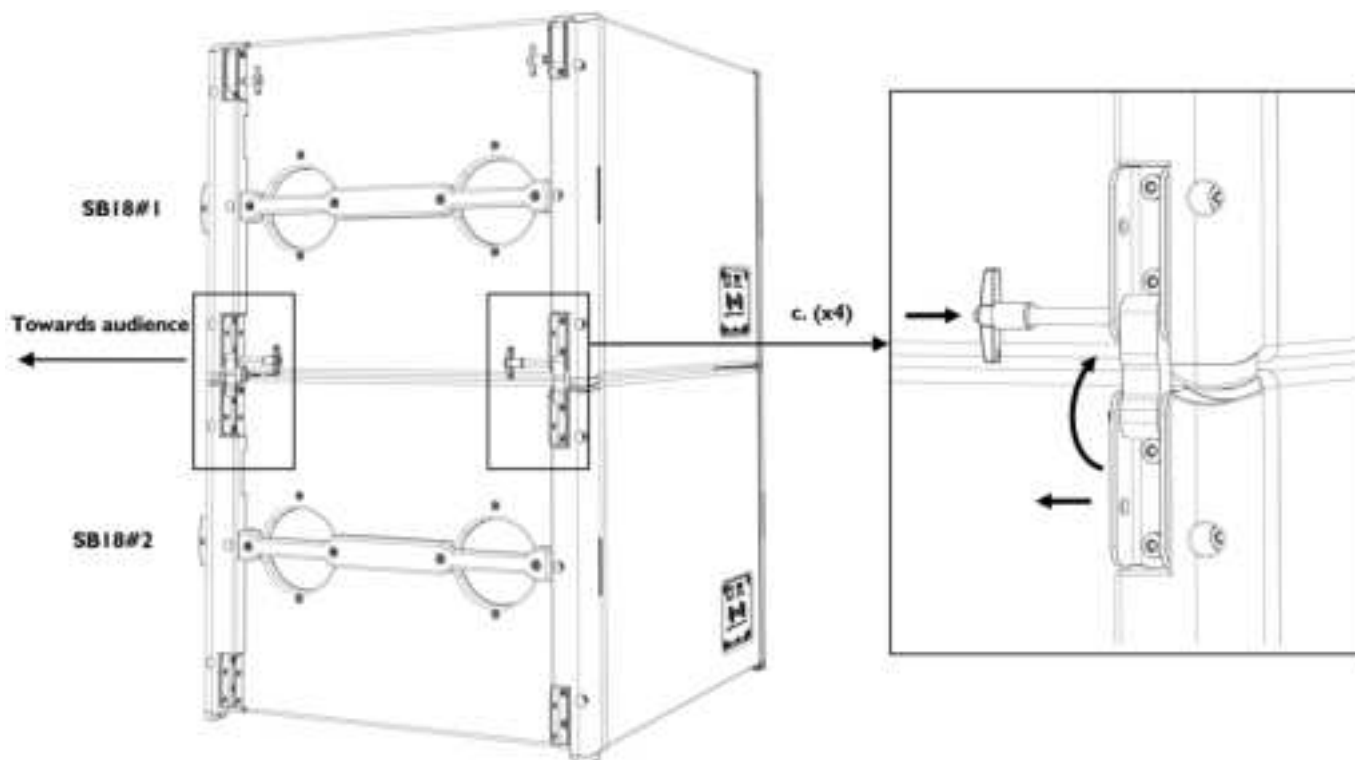

5. Put the M-BUMP onto SB18#1 by keeping the orientation and attach the four rigging arms of SB18#1 to the M-BUMP as follows: disconnect a T-BLP from SB18#1, rotate the rigging arm up, re-connect the T-BLP to the M-BUMP rigging point and the rigging arm ; repeat this procedure until all 4 arms are secured.

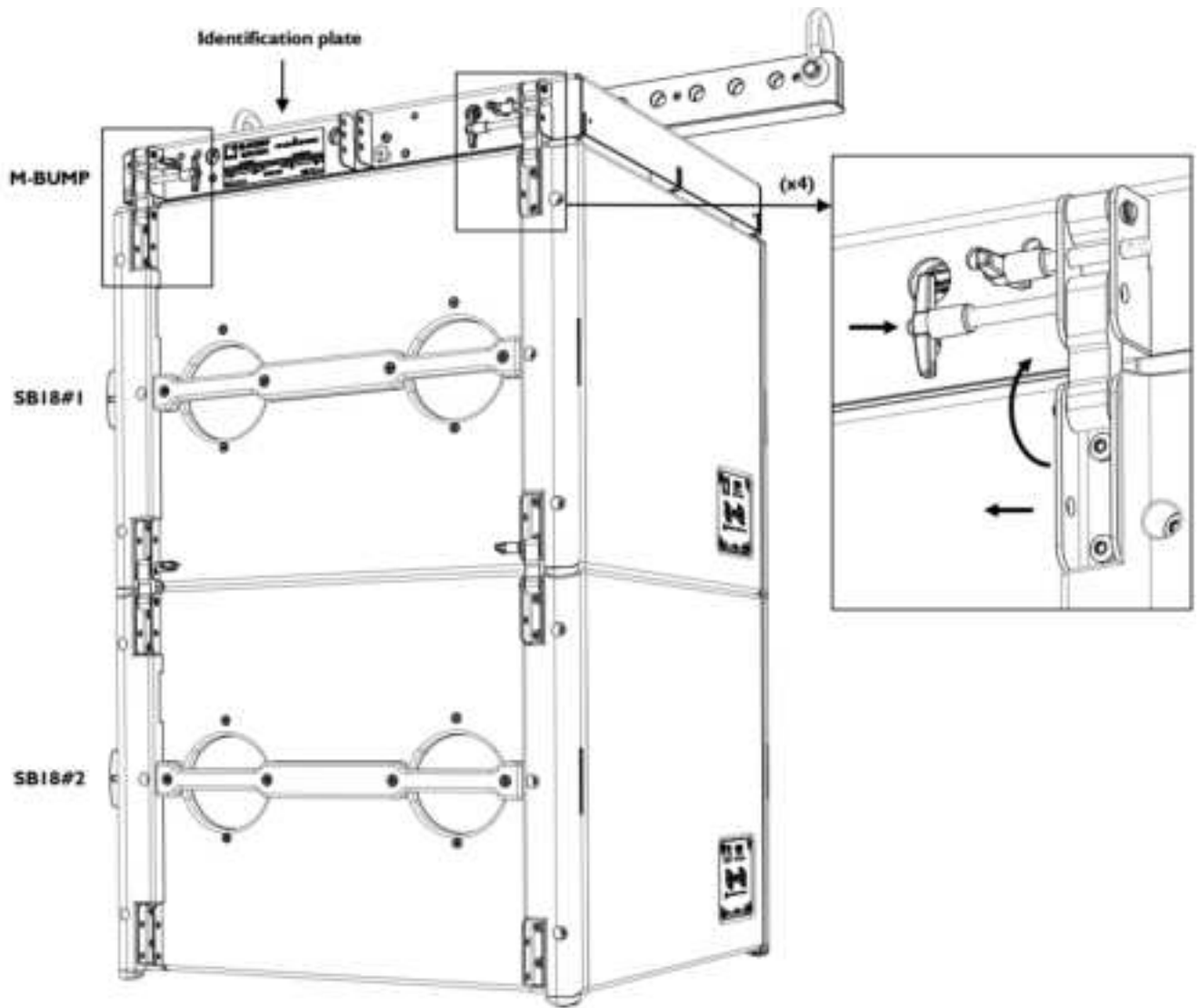

6. Attach the motor hook(s) or stinger(s) to the shackle(s).
7. Raise the array so that it is possible to place another stack of two SB18 under it.

8. Build another stack of two SB18 enclosures (hereafter called SB18#3 and SB18#4) by applying step 4 (p.75).

i Orient all SB18 composing the array towards the audience to obtain an omnidirectional acoustic pattern or turn one SB18 out of four from front to rear to obtain a cardioid acoustic pattern (refer to the [SB18 user documentation](#)). As an example, the following figures show a cardioid SB18 array.

9. Attach SB18#3 to SB18#2 as follows (see also the figure below):

- Lower the array onto SB18#3 while aligning the four rigging points between SB18#2 and SB18#3.
- Attach the four rigging arms of SB18#3 to SB18#2 as follows: disconnect a T-BLP from SB18#3, rotate the rigging arm up, re-connect the T-BLP to the SB18#2 rigging point and the rigging arm ; repeat this procedure until all 4 arms are secured.

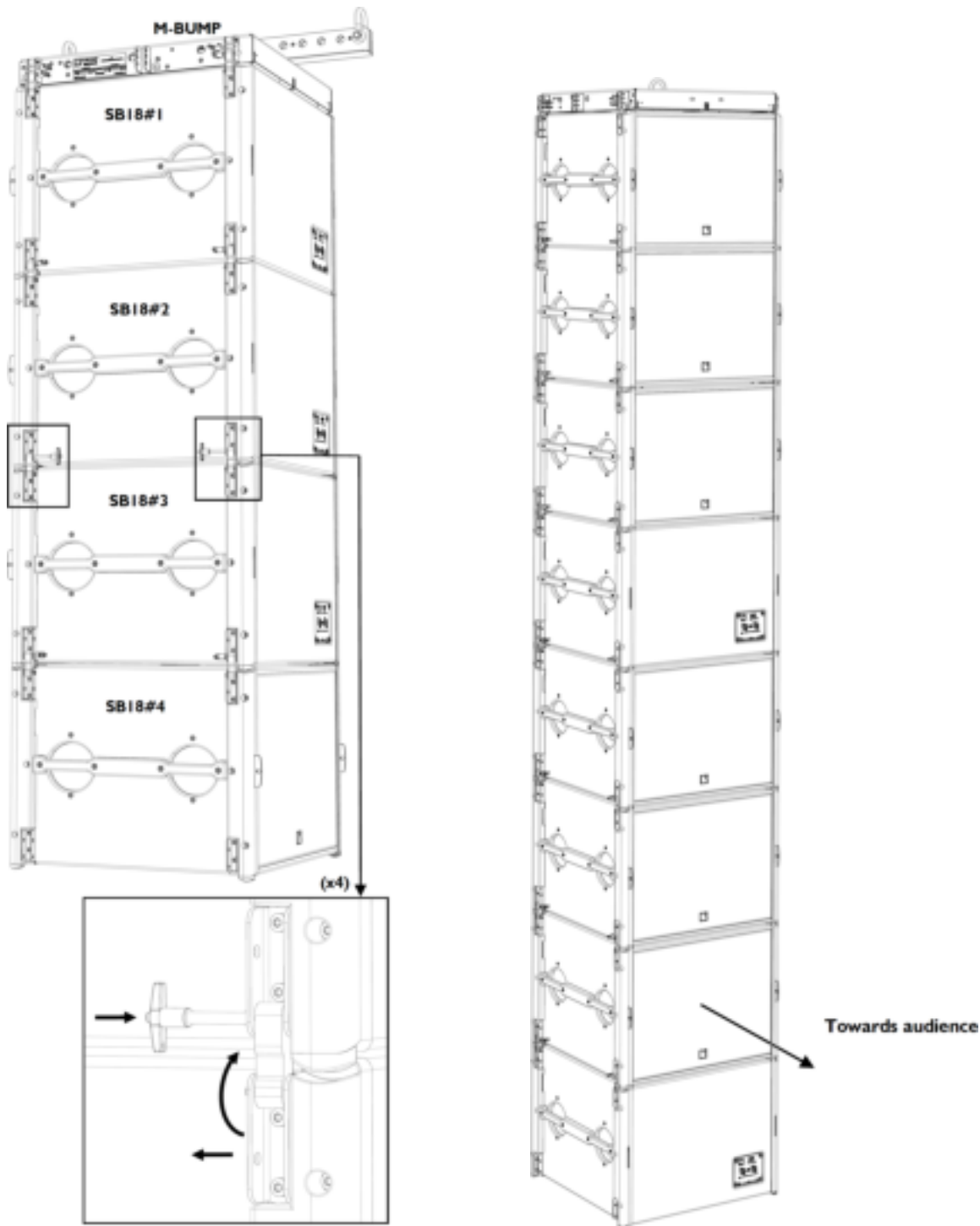

10. If the array is intended to be an SB18 standalone array, apply the following last procedure (see also the figure above):

- Repeat steps 7 (p.76) to 9 until all SB18 composing the array are rigged.
- Raise the array to the desired height.
- Secure the M-BUMP to the main rigging structure using two safety slings (not provided).

If the array is intended to be an SB18/Kara II mixed array, place a full Kara II flight-case at the rigging location and remove the lid. Direct the front face of the 3-Kara II array towards the audience. In the following, the array will be designated as ARRAY#1 and the enclosures as KARA#1 to KARA#3 from top to bottom.

i For clarity purposes, the procedure is continued with an array composed of two SB18 enclosures.

11. Check the inter-enclosure connections in ARRAY#1 (repeat for each side):

- a) For both front rigging points, verify that the front arm is open and locked to 2 Kara II by 2 R-BLP inserted in yellow link holes.
- b) For both rear rigging points, verify that the angle arm cursor is aligned with the 0° angle value and locked to 2 Kara II by 2 R-BLP, the upper one inserted in a yellow link hole and the bottom one inserted into angle hole 0°/2°/4°.

! **Risk of blocked ball-locking pin.**

Be careful not to trap the ball-locking pin tether between the rigging arm and the side handle.

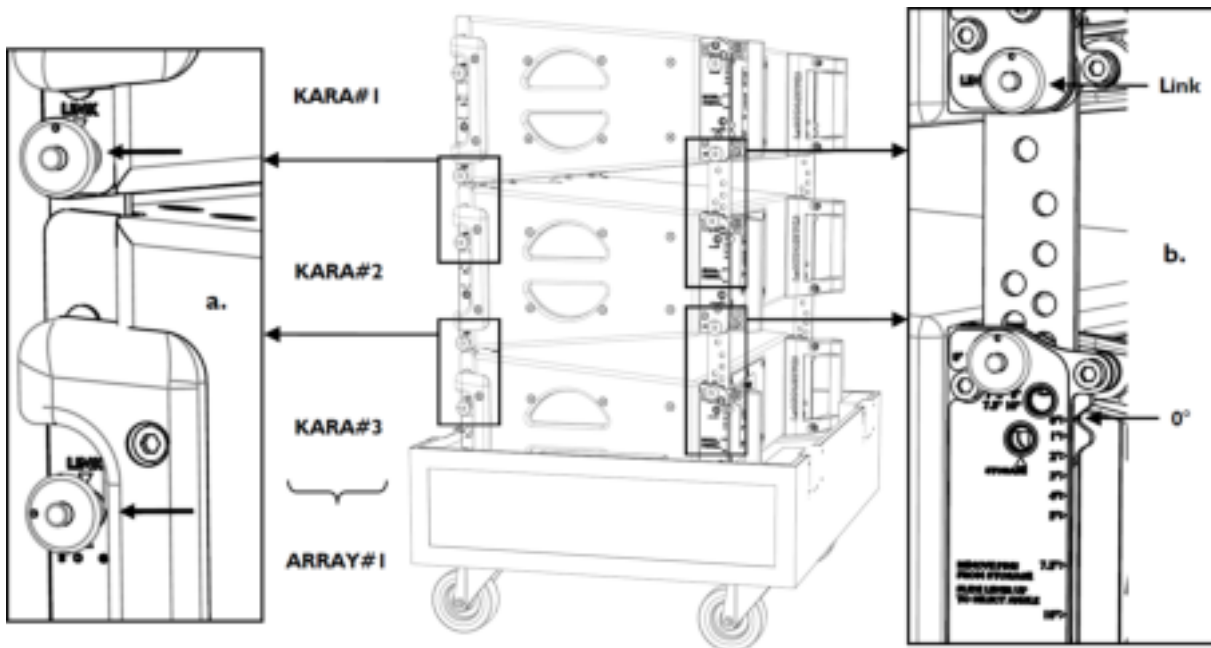
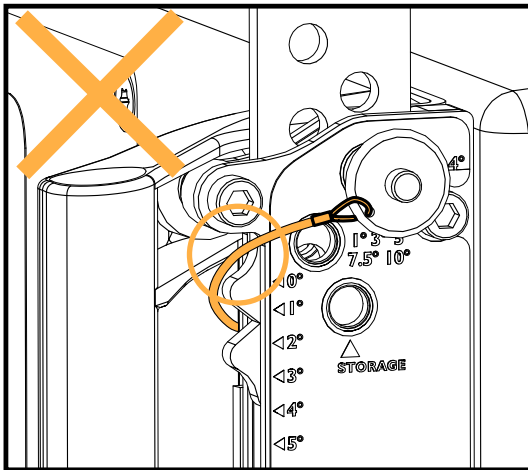

12. On KARA#1, take the 4 arms out as follows (repeat for each side):

- a) Remove the front top R-BLP from storage position, rotate the front arm up, slide it down, and secure by reinserting the R-BLP into the yellow link hole.
- b) Remove the rear top R-BLP, slide the angle arm so as to align the cursor with the 5° angle value, and secure by reinserting the R-BLP into angle hole 1°/3°/5°/7.5°/10°.

- i** It is recommended to select the 5° angle on the Kara II intended to be linked to the M-BUMP. By doing this, the KARA#1 axis is parallel to the M-BUMP, so that a laser secured on M-BUMP can give the site angle of the KARA#1 enclosure.

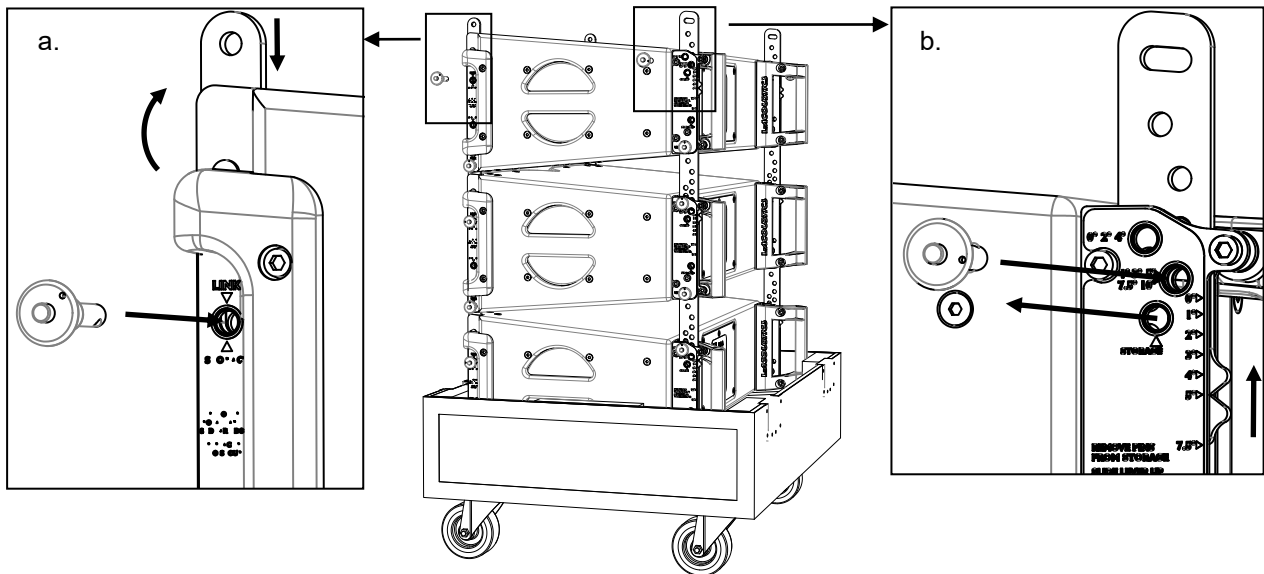

- 13.** Place another M-BUMP at the rigging location and remove the 4 R-BLP. Put the M-BUMP on ARRAY#1 by aligning the four rigging points and secure by re-inserting the 4 R-BLP.

- i** Turn the M-BUMP so that the text of the identification plate is readable and the laser slits are directed towards the audience.

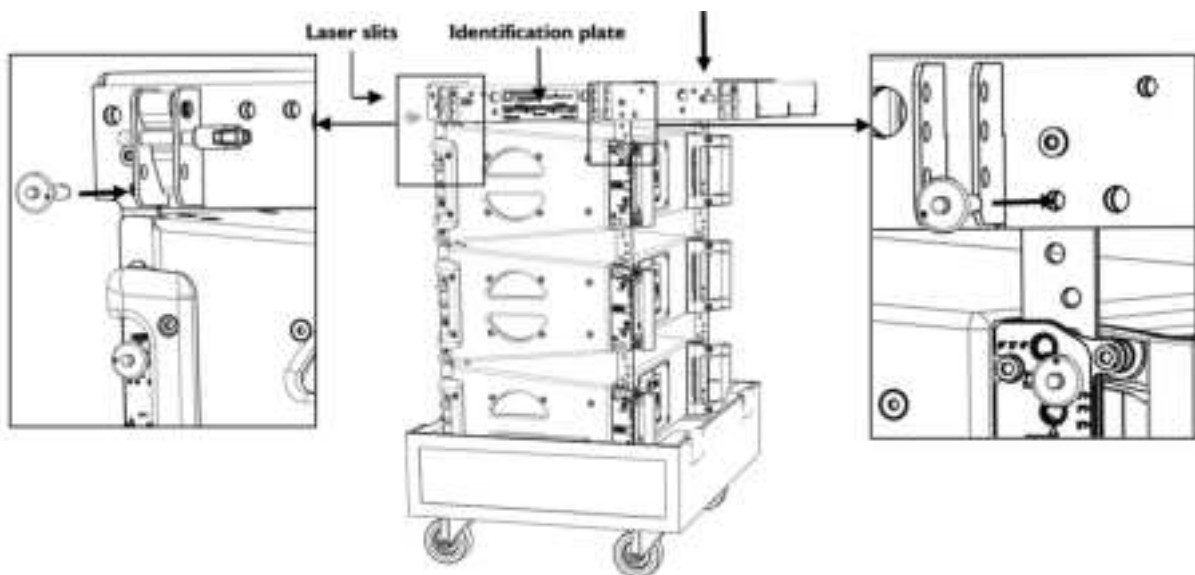

- 14.** Raise the SB18 array slightly higher than ARRAY#1, place ARRAY#1 beneath it, and lower the SB18 array so as to align its 4 rigging points with those of ARRAY#1. The bottom SB18 and the M-BUMP must be in contact.
- 15.** Attach the 4 rigging points between the bottom SB18 and the M-BUMP as follows (repeat for each one):
- Remove the external T-BLP from the M-BUMP.
 - Rotate the arm out.
 - Secure to the SB18 by re-inserting the T-BLP.

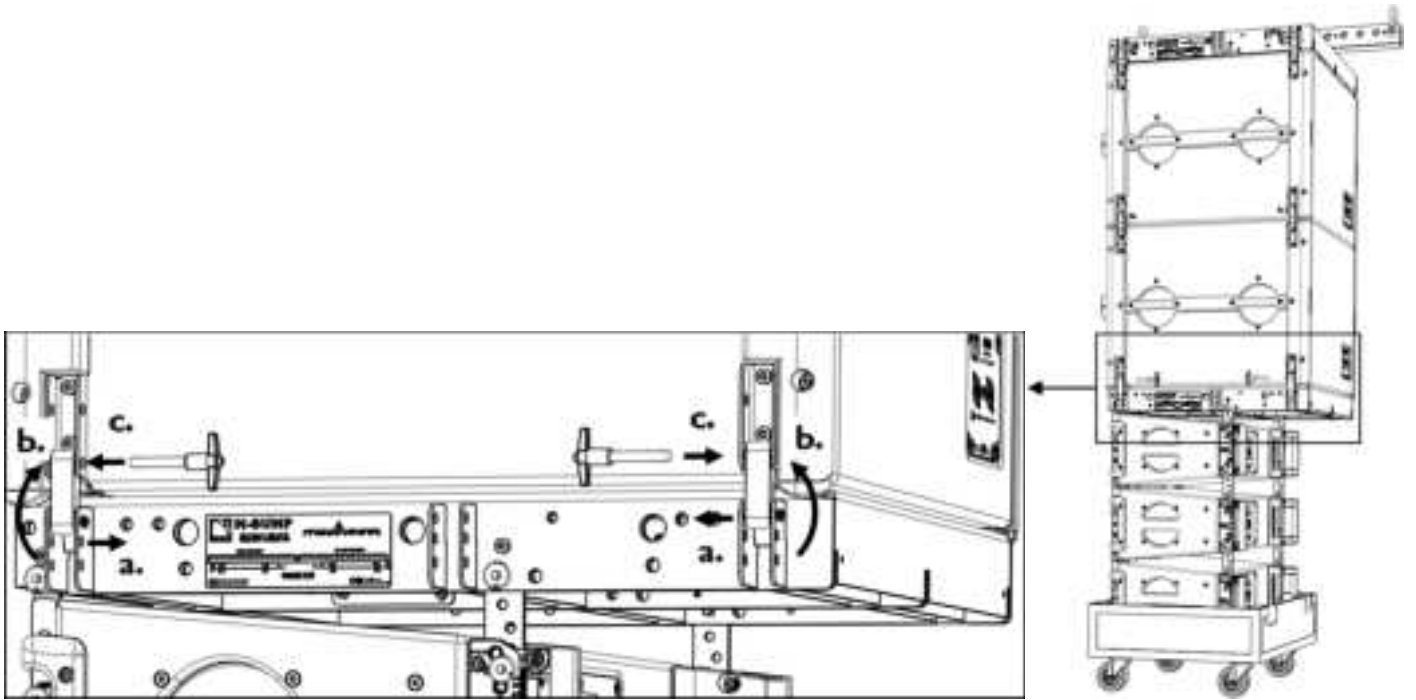

- 16.** Raise the array to a height for which the angle arms of ARRAY#1 are within comfortable reach and remove the flight-case from the rigging location.
- 17.** Continue the procedure by applying Kara II standalone array mounting procedure, steps 9 (p.57) to 21.

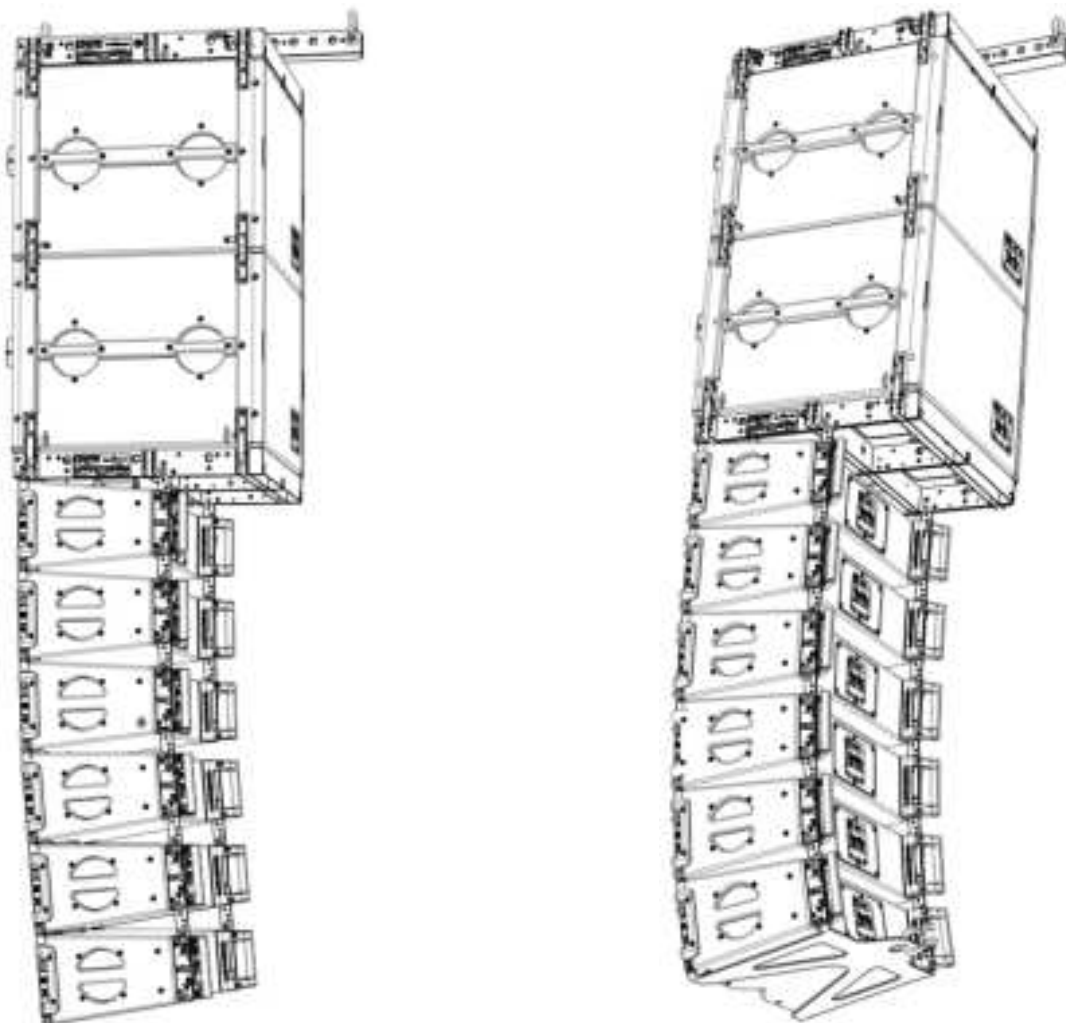

Array removal

About this task

! All along the procedure:
Strictly follow the sequence of the successive steps.
Systematically verify that each BLP is fully inserted.

! For clarity purposes the loudspeaker cable removal procedure will not be described.
The loudspeaker cables will not be represented on the figures.

Procedure

1. In case of SB18 standalone array, directly go to step **8** (p.82).

In case of SB18/Kara II mixed array, begin the procedure by applying the Kara II standalone array removal procedure, steps **1** (p.61) to 13, and then continue to next step.

2. Lower ARRAY#1 into the tray. The bottom SB18 must be resting on the M-BUMP.

3. Disconnect the 4 rigging points between the bottom SB18 and the M-BUMP as follows (repeat for each point):

- a) Remove the T-BLP from the M-BUMP.
- b) Rotate the arm down.
- c) Re-insert the T-BLP on the M-BUMP.

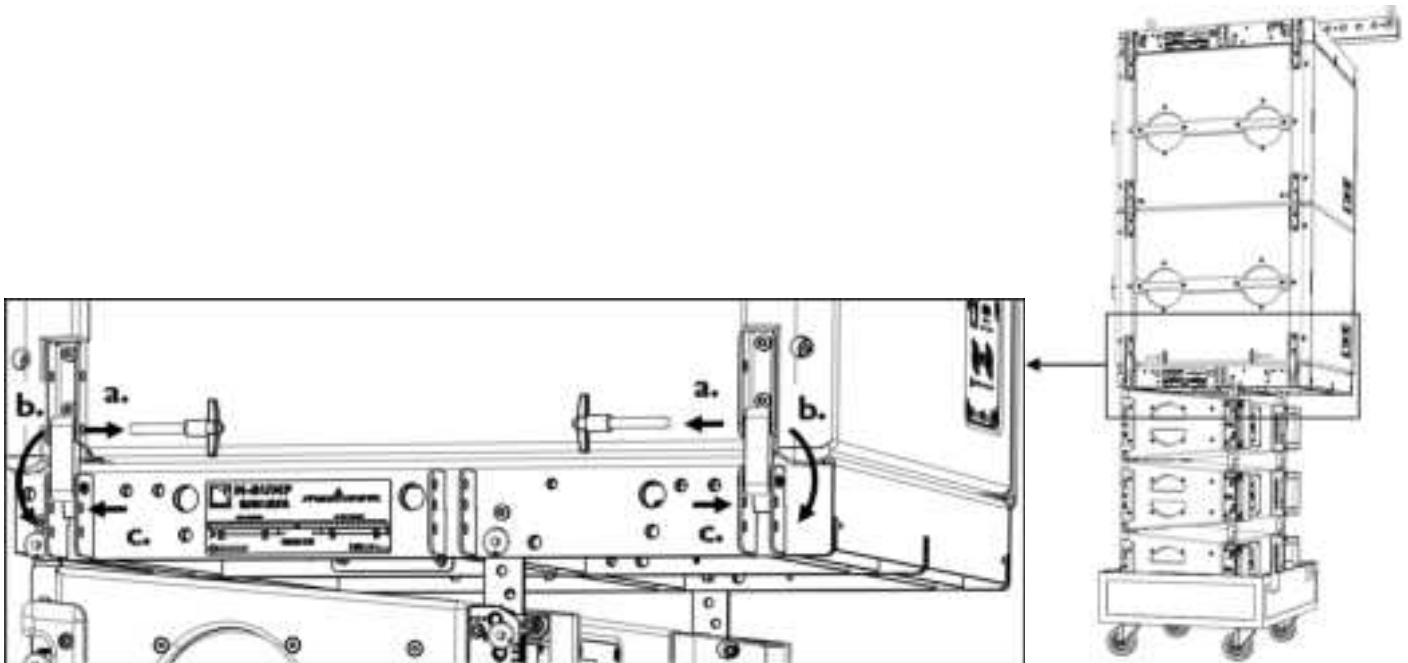

4. Push ARRAY#1 away from under the SB18 array.

5. Remove the 4 R-BLP from the M-BUMP and remove the M-BUMP from ARRAY#1.

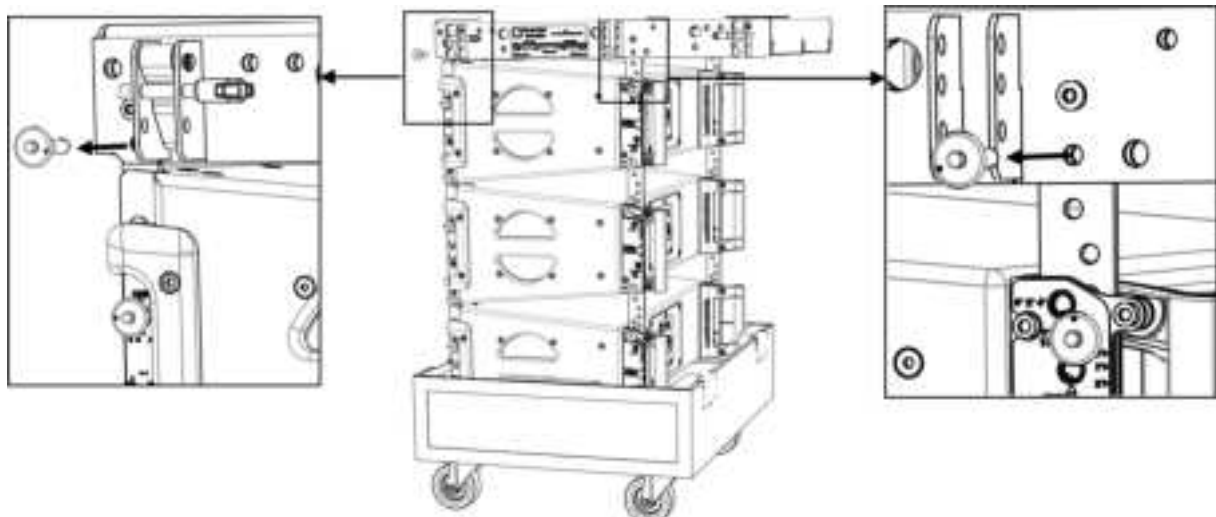

6. Set ARRAY#1 for transport as follows:

- a) On each side of KARA#1, remove the front top link R-BLP, slide the front arm up, rotate down, and secure by re-inserting the R-BLP into the top storage hole.
- b) On each side of the KARA#1, remove the rear top angle R-BLP, slide the angle arm so as to align the cursor with the storage position, and secure by re-inserting the R-BLP into the top storage hole.
- c) Put the flight-case lid on.

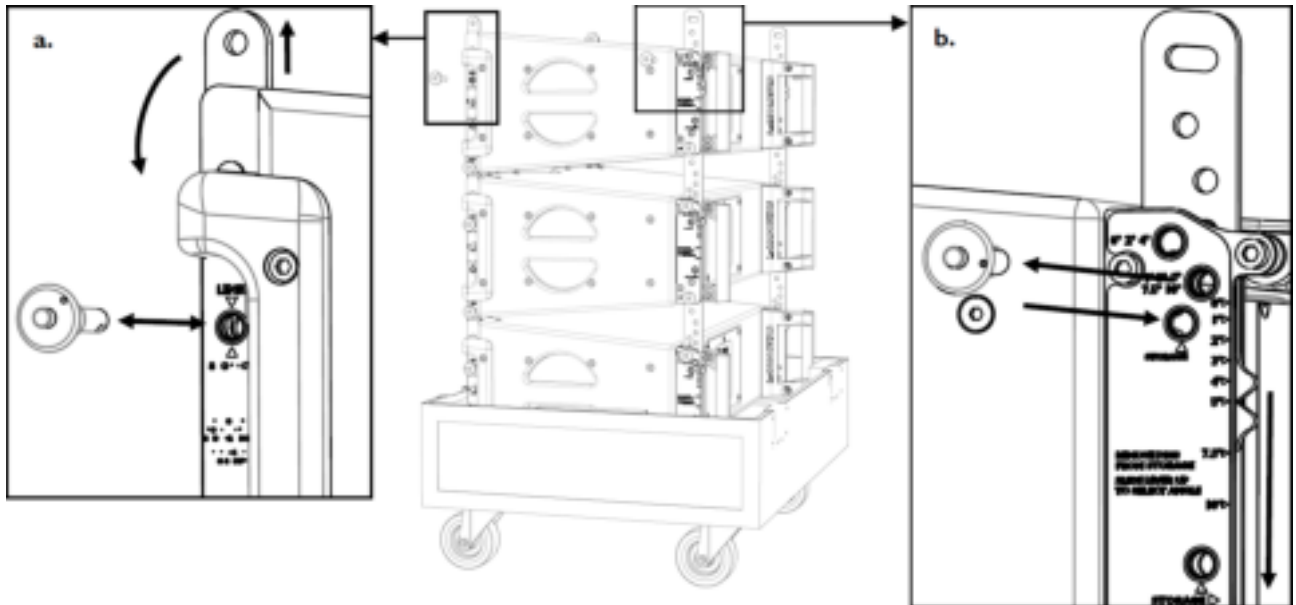

7. Set the M-BUMP for transport by re-inserting the 4 R-BLP into their storage locations.

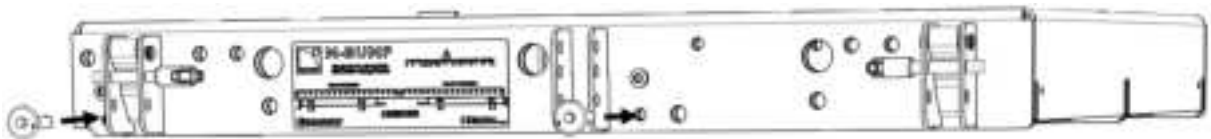

i For clarity purposes, the procedure is continued with an array composed of four SB18 enclosures.

- 8.** If not already done, remove both safety slings from the M-BUMP.
- 9.** Lower the array until the bottom SB18 (hereafter called SB18#4 as an example) rests on the ground and the SB18 above (hereafter called SB18#3) rests onto it.

10. Detach SB18#3 from SB18#2 as follows:

- a) Disconnect a T-BLP from the bottom of SB18#2.
- b) Rotate the rigging arm down.
- c) Re-connect the T-BLP to SB18#3 so as to lock the rigging arm in closed position.
- d) Repeat this procedure until all 4 arms are locked in closed position.

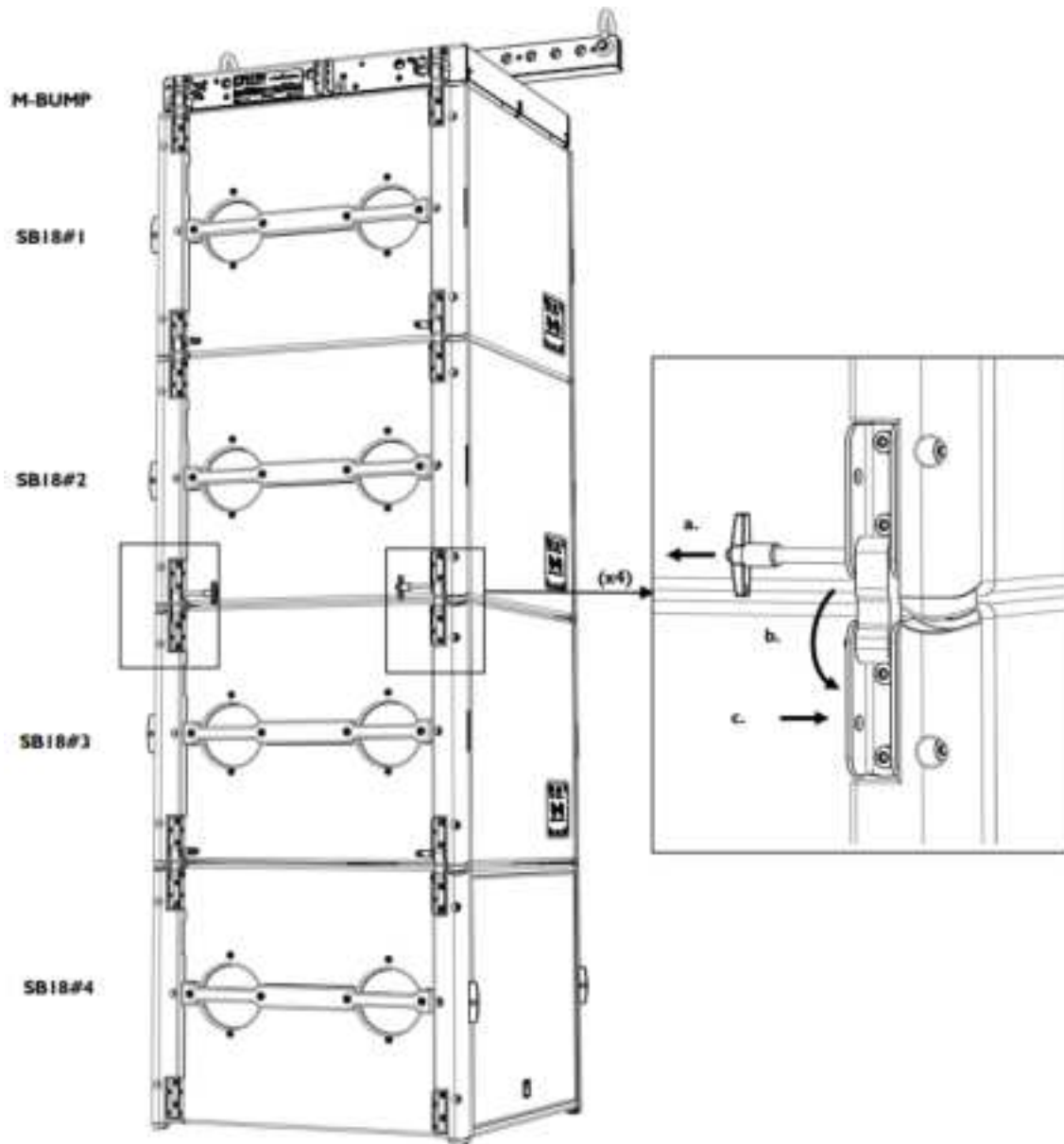

11. Raise the array so that SB18#2 is separated from SB18#3.

12. Attach two dolly boards to SB18#3 and 4.

13. Detach SB18#4 from SB18#3 by applying step 10 (p.83).

14. Remove SB18#3 and 4 from the rigging location.

15. Repeat steps 9 (p.82) to 14 to separate the SB18s from the array just until SB18#1 and 2 are remaining attached to the M-BUMP.

16. Lower the array until it rests on the ground.

17. Remove the motor hook(s) or stinger(s) from the shackle(s) of the M-BUMP.

18. Remove the M-BUMP from SB18#1 as follows:

- a) Disconnect a bottom T-BLP from the M-BUMP.
- b) Rotate the rigging arm down.
- c) Re-connect the T-BLP to SB18#1 so as to lock the rigging arm in closed position.
- d) Repeat this procedure until all 4 arms are locked in closed position.
- e) Remove the M-BUMP from the array.

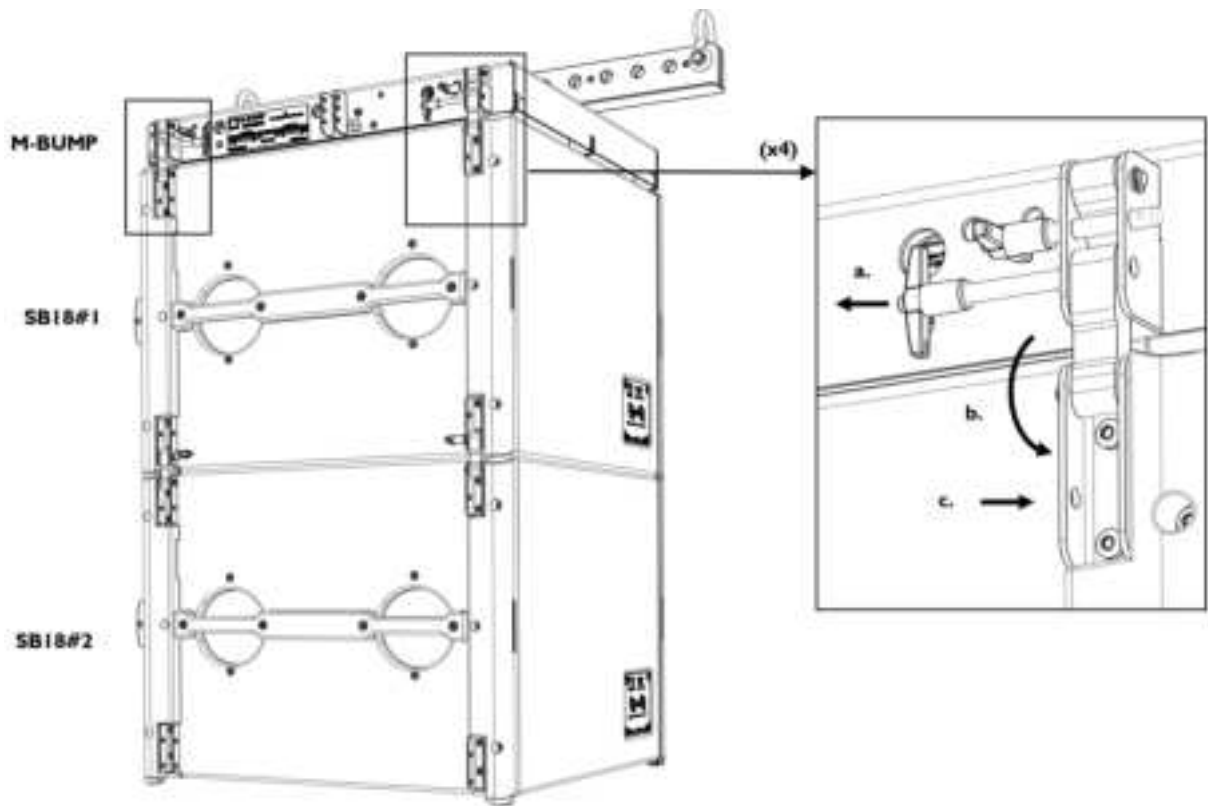

19. If necessary, set the M-BUMP for transport by removing each M-BAR as follows: remove both T-BLP from the M-BAR studs, remove the M-BAR, and re-insert both T-BLP in their storage locations.

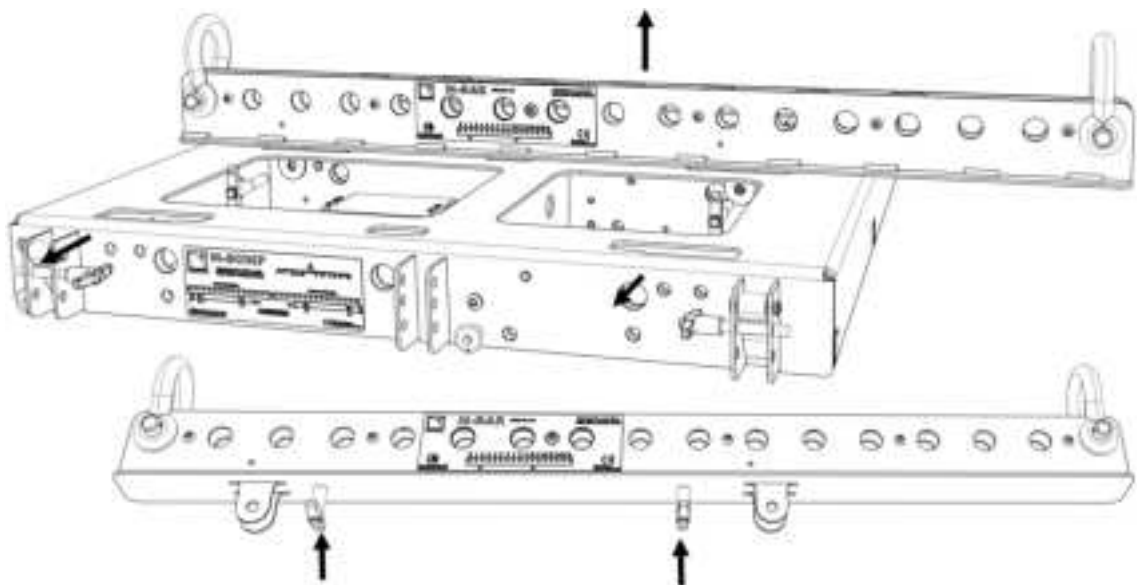

20. Attach two dolly boards to SB18#1 and 2.

21. Detach SB18#2 from SB18#1 by applying step 10 (p.83) and remove both subwoofers from the rigging location.

Using KARA-MINIBU

Modeling and safety

Any loudspeaker assembly must be modeled before installation so as to ensure acoustical and mechanical conformity. This can be done using L-Acoustics [Soundvision Software](#) which will assist the user to:

- Determine the number of required Kara II enclosures (acoustic data not available for subwoofers).
- Calculate the array site angle and the inter-enclosure angles.
- Check the mechanical conformity of the loudspeaker assembly.



The KARA-MINIBU/KARA-MINIBUEX structure can nominally fly an array of up to 2 SB18/6 Kara II or 4 SB18 along with all loudspeakers cables (refer to [Mechanical safety](#) (p.31)). However, this maximum number can decrease in line with the array curvature.

Always refer to the mechanical data and warning indications provided in [Soundvision Software](#) (**Mechanical Data** section) to verify the mechanical conformity of the loudspeaker assembly before installation.

The Kara II, SB18, KARA-MINIBU, and KARA-MINIBUEX fully integrated rigging systems allow assembling the array with no need for any external accessory.

The following first procedure describes how to fly a vertical SB18/Kara II array using two KARA-MINIBU/KARA-MINIBUEX rigging structures. It is recommended to assemble the Kara II by successively adding arrays of 3 enclosures (called ARRAY#1 and ARRAY#2 in the order of appearance in the procedure). The second procedure describes how to disassemble the array.

Array mounting

About this task



All along the procedure:

Strictly follow the sequence of the successive steps.

Systematically verify that each BLP is fully inserted.

Systematically verify that the bolt is fully driven on each shackle.

Systematically verify that each bolt is fully driven on the KARA-MINIBUEX.



For clarity purposes the loudspeaker cabling procedure will not be described.

The loudspeaker cables will not be represented on the figures.

Use a strain relief to avoid mechanical stress at the connector locations due to cable weight.

The motor hooks or stingers will not be represented on the figures.

Required tools

- electric screwdriver with torque selector
- 6 mm hex bit
- 13 mm hex key

Procedure

1. Assemble a KARA-MINIBU/KARA-MINIBUEX rigging structure as follows:

- Turn the KARA-MINIBU so that the text of the identification plate is readable.
- Position a first KARA-MINIBUEX on the laser plate side of the KARA-MINIBU by turning it feet pointing up and inserting the stud into the slit of the KARA-MINIBU located near the laser plate.
- Drive 3 bolts into the 3 holes shown the figure below (6 mm hex bit, 13 mm hex key, 7 N.m/63 in.lb f).
- Repeat the procedure with a second KARA-MINIBUEX on the other side of the KARA-MINIBU.
- Attach the shackle(s) to the KARA-MINIBU according to the chosen configuration (see [KARA-MINIBU rigging options](#) (p.197)).

i If the array is intended to be flown in pullback configuration, attach a single shackle to the rear pullback hole (see [KARA-MINIBU](#) (p.24)).

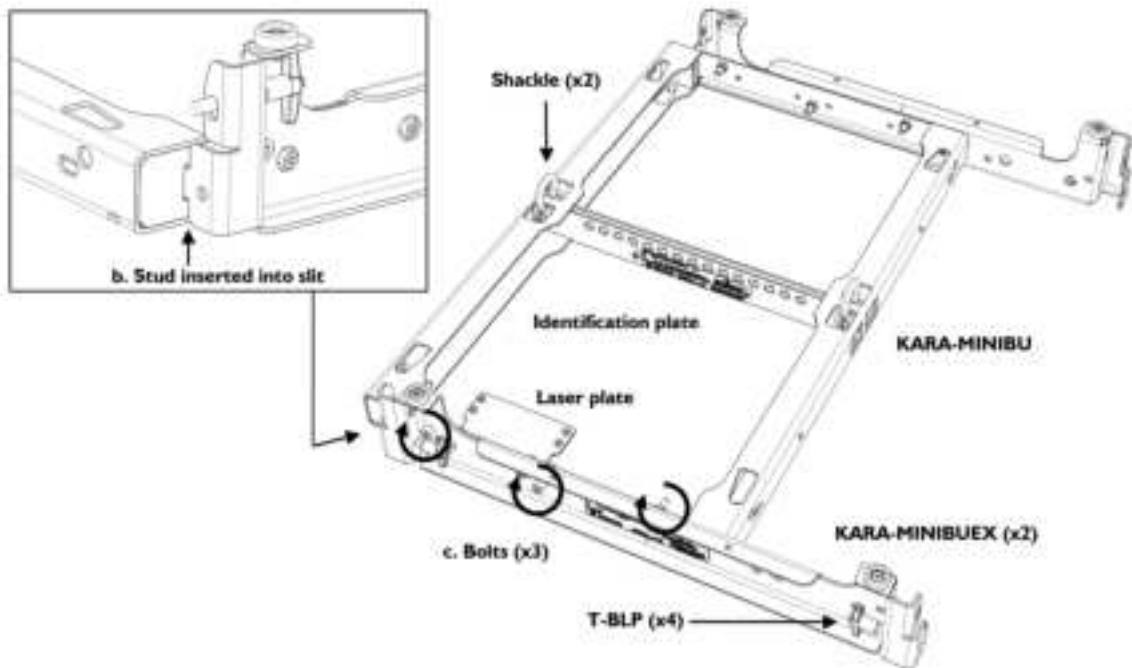

2. Attach two SB18 (hereafter called SB18#1 and SB18#2) together as follows:

- Bring two SB18 to the rigging location and remove the dolly boards.
- Arrange both SB18 in a vertical array, front faces towards audience and logos down. In the following, SB18#1 will designate the top subwoofer and SB18#2 the bottom one.
- Remove a T-BLP from SB18#2, rotate the link arm up, then re-insert the T-BLP into the SB18#1 link point and the link arm. Repeat this step until all four arms are secured.

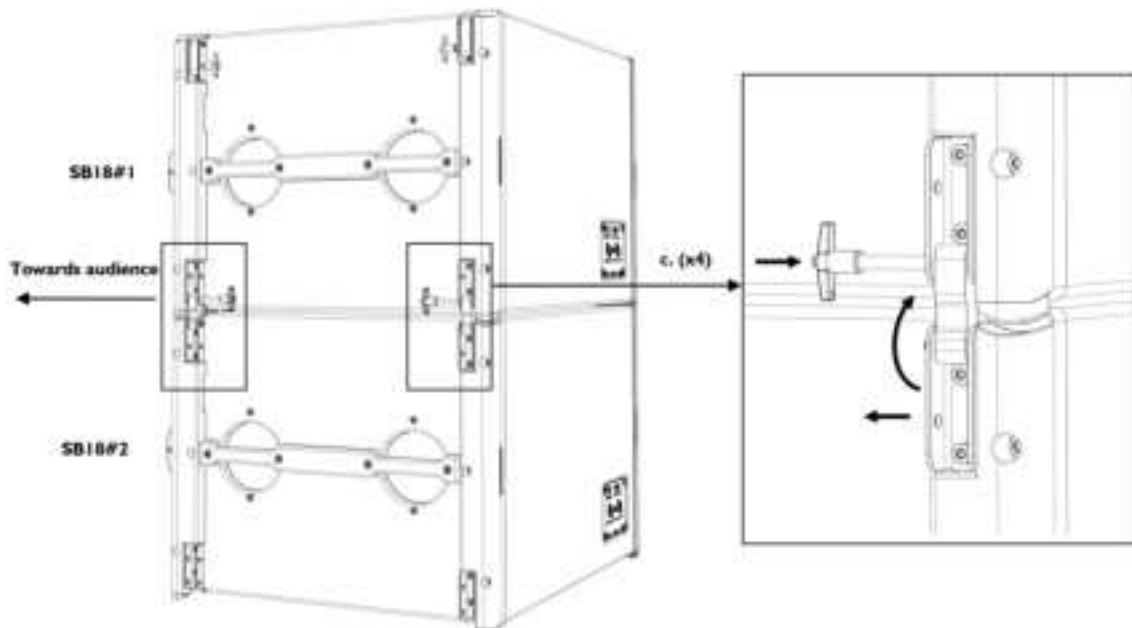

3. Attach the KARA-MINIBU/KARA-MINIBUEX to SB18#1 as follows:
 - a) Remove the four top T-BLP from the SB18#1 and turn the four link arms up.
 - b) According to the chosen configuration (see [KARA-MINIBU rigging options](#) (p.197)), position the KARA-MINIBU/KARA-MINIBUEX above SB18#1 and lower it sliding the SB18#1 link arms into the KARA-MINIBUEX arm guides.
 - c) Re-insert the four T-BLP into the KARA-MINIBUEX link points and the SB18#1 link arms.

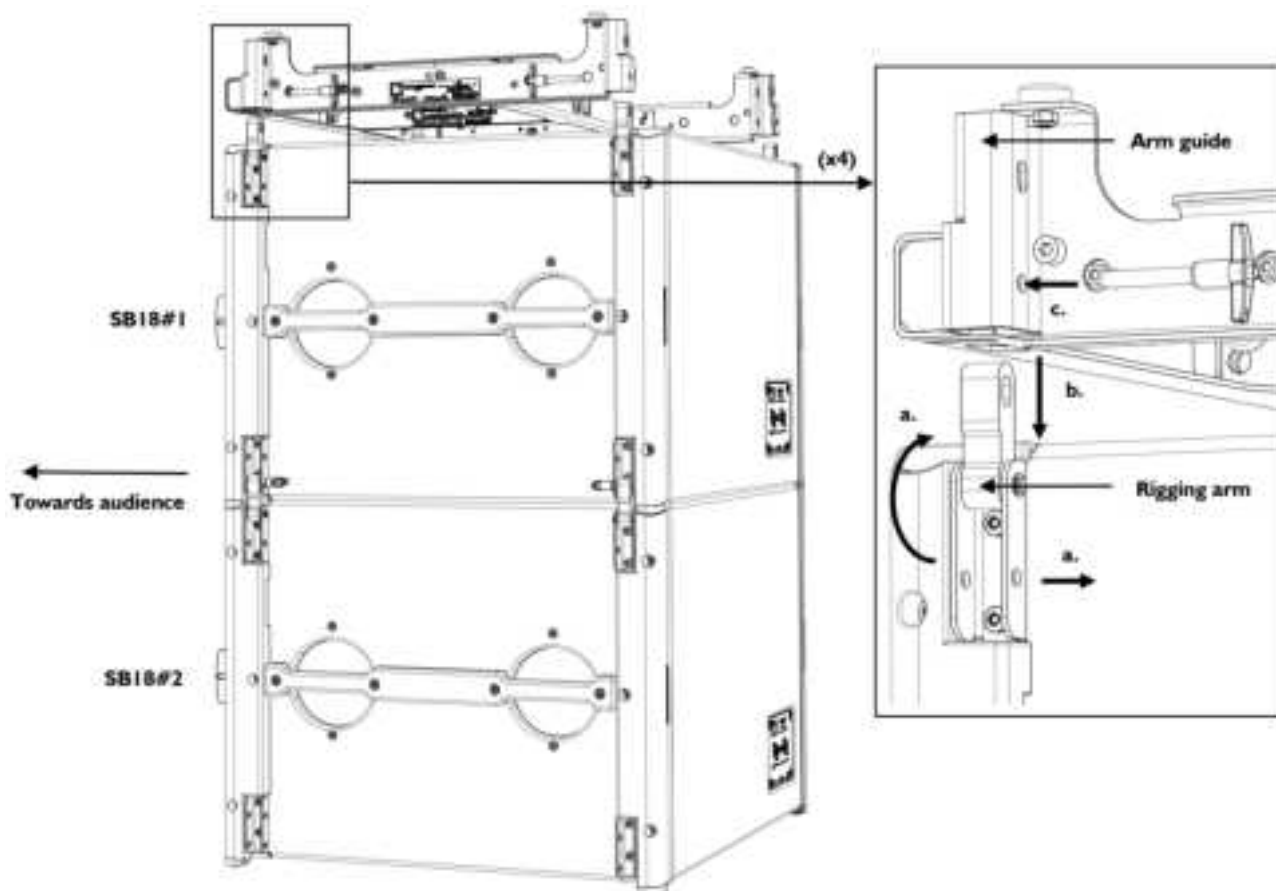

4. Attach the motor hook(s) or stinger(s) to the shackle(s) and raise the array to a height of 1.3 m/4.3 ft.

5. If the array is intended to be an SB18/Kara II mixed array, directly go to step 9 (p.88).

If the array is intended to be an SB18 standalone array, attach two additional SB18 enclosures (hereafter called SB18#3 and SB18#4) under the array by applying step 2 (p.86) and then continue the procedure from step 6 (p.87) below.

- i** Orient all SB18 composing the array towards the audience to obtain an omnidirectional acoustic pattern or turn one SB18 out of four from front to rear to obtain a cardioid acoustic pattern (refer to the [SB18 user documentation](#)). As an example, the following figures show a cardioid SB18 array.

6. Attach SB18#3 to SB18#2 as follows:
 - a) While aligning the four link points between SB18#2 and SB18#3, lower the array onto SB18#3.
 - b) Remove a T-BLP from SB18#3.
 - c) Rotate the link arm up.
 - d) Secure the link arm to SB18#2 by re-inserting the T-BLP into the SB18#2 bottom link point.
 - e) Repeat the last three steps until all four arms are secured to SB18#2.

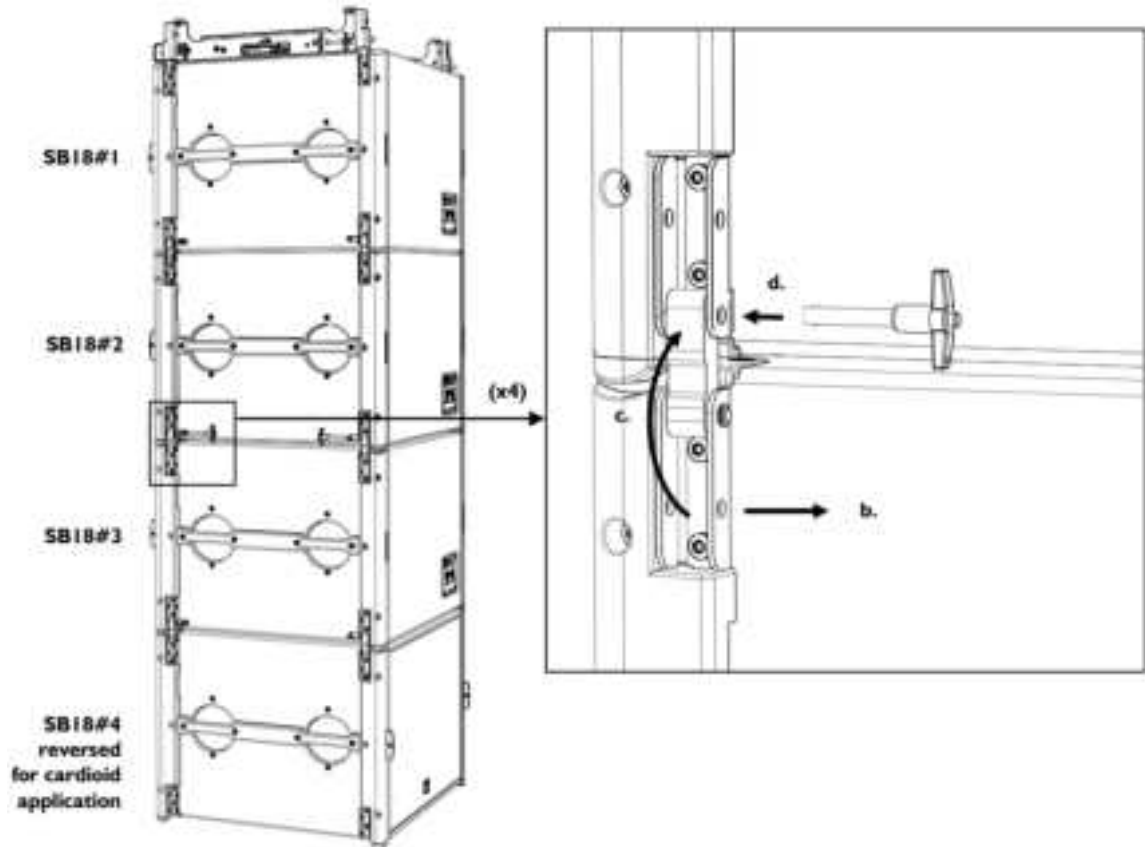

7. Raise the array to the chosen height.
8. Secure the KARA-MINIBU to the main rigging structure by using two safety slings (not included).
9. Bring a full Kara II flight-case to the rigging location and remove the lid. Direct the front face of the Kara II array towards the audience. In the following, the array will be designated as ARRAY#1 and the enclosures as KARA#1 to KARA#3 from top to bottom.
10. Check the inter-enclosure attachments in ARRAY#1 as follows (repeat on both sides of the array):
 - a) Verify that each front arm (x2) is open and secured to the **link** holes of two Kara II by two R-BLP.

i A **link** hole is indicated by a yellow circle.

- b) Verify that each angle arm (x2) has the cursor aligned with angle label 0° and is secured to two Kara II by two R-BLP, the top one being inserted into the **link** hole and the bottom one into angle hole $0^\circ/2^\circ/4^\circ$.

! **Risk of blocked ball-locking pin.**
Be careful not to trap the ball-locking pin tether between the rigging arm and the side handle.

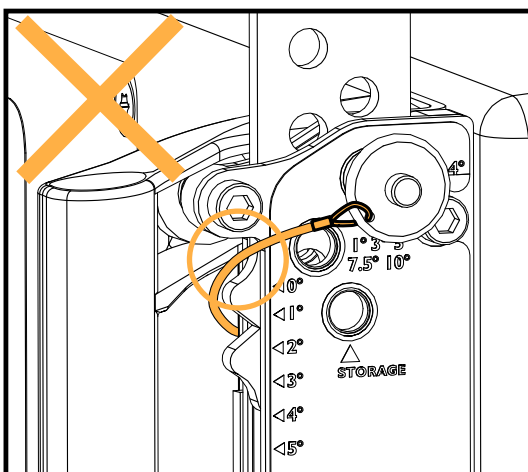

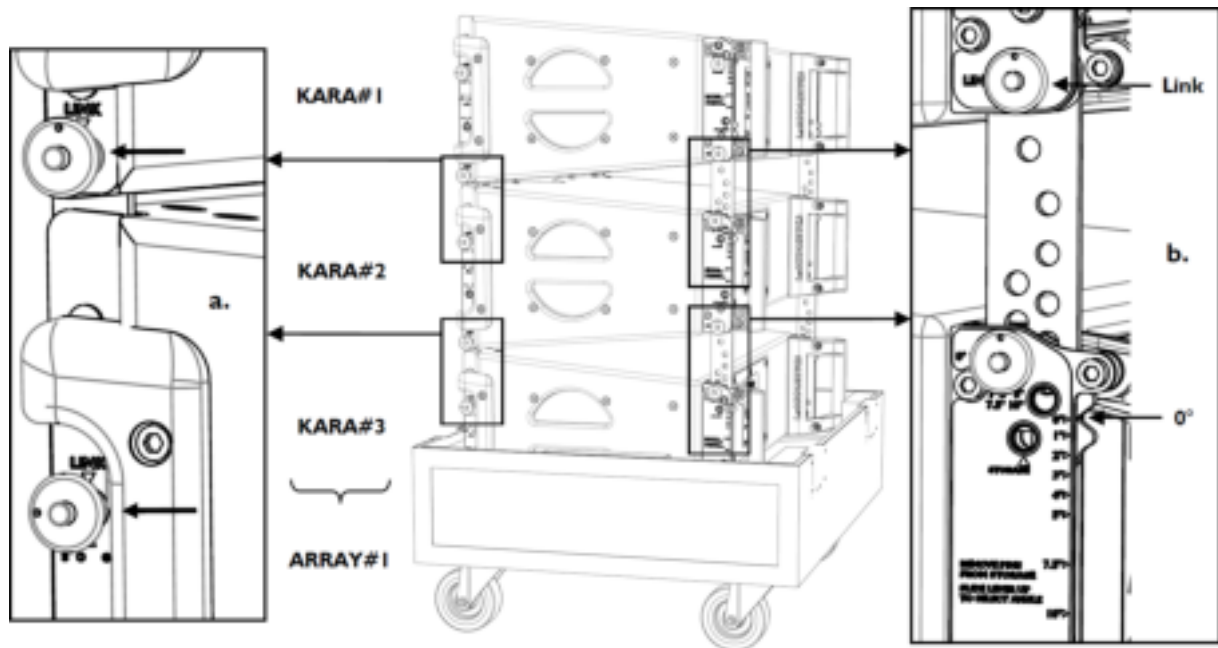

11. Open the four KARA#1 arms as follows (repeat on both sides of the enclosure):

- a) Remove the front top R-BLP from its **storage** hole, rotate the front arm up, slide it down, and lock it in place by re-inserting the R-BLP into the front top **link** hole.

i The front top **storage** and **link** holes are the same.

- b) Remove the rear top R-BLP from its **storage** hole, slide the angle arm so as to align the cursor with angle label 5°, and lock it in place by re-inserting the R-BLP into angle hole 1°/3°/5°/7.5°/10°.

i It is recommended to select the 5° angle on the Kara II intended to be attached to the KARA-MINIBU. By doing this, the KARA#1 axis is parallel to the KARA-MINIBU, so that a laser secured on KARA-MINIBU can give the site angle of the KARA#1 enclosure.

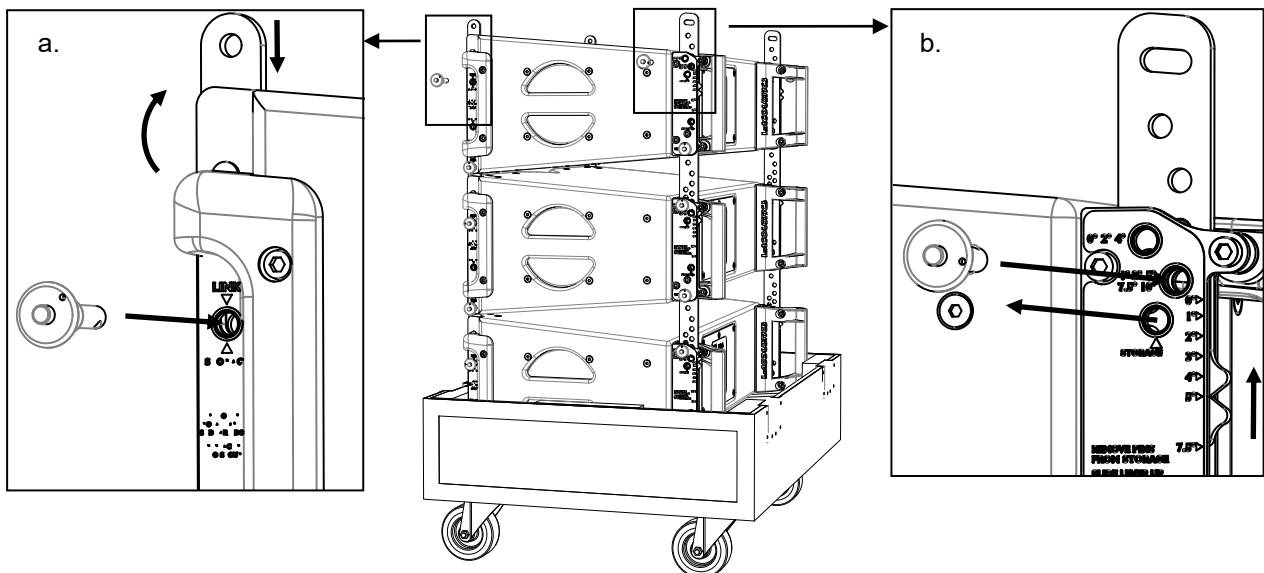

12. Assemble another KARA-MINIBU/KARA-MINIBUEX rigging structure by applying step 1 (p.86) without attaching shackles.

13. Attach the KARA-MINIBU/KARA-MINIBUEX to KARA#1 as follows:

- a) Remove the four R-BLP from the KARA-MINIBU.
- b) Turn the KARA-MINIBU so that the text of the identification plate is readable and the laser plate is placed at the front (towards the audience).

- c) While keeping this orientation, align the four link points of KARA-MINIBU with the four arms of KARA#1 and secure each pair together by re-inserting the four R-BLP into the same holes (insert both rear R-BLP first).



The KARA-MINIBUEX elements must extend beyond the rear of the array.

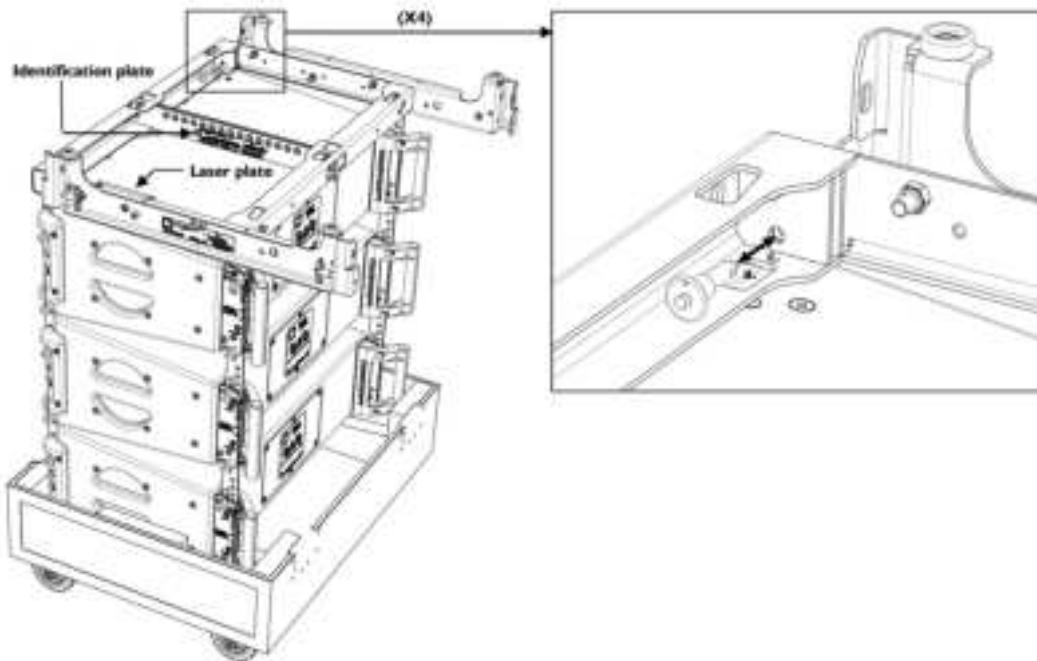

14. Place ARRAY#1 beneath the SB18 array.

15. Attach ARRAY#1 to the SB18 array as follows:

- a) Remove the four T-BLP from the **storage** holes of both KARAMINIBUEX.
 b) Lower the SB18 array so as to align its four bottom link points with those of both KARA-MINIBUEX.



Do not stack the SB18 array onto the Kara II array.

- c) Secure the link points together by re-inserting the four T-BLP into the KARA-MINIBUEX and bottom SB18 **link** holes.

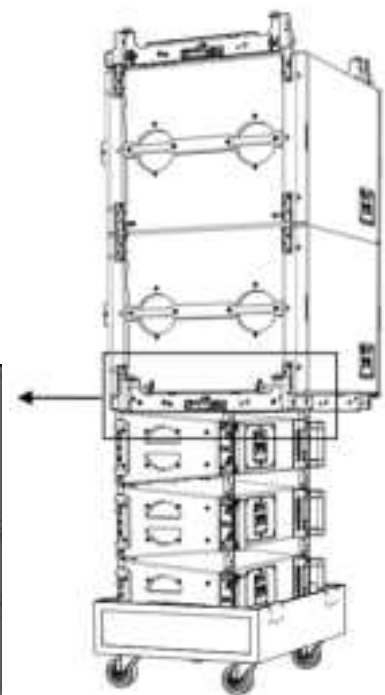
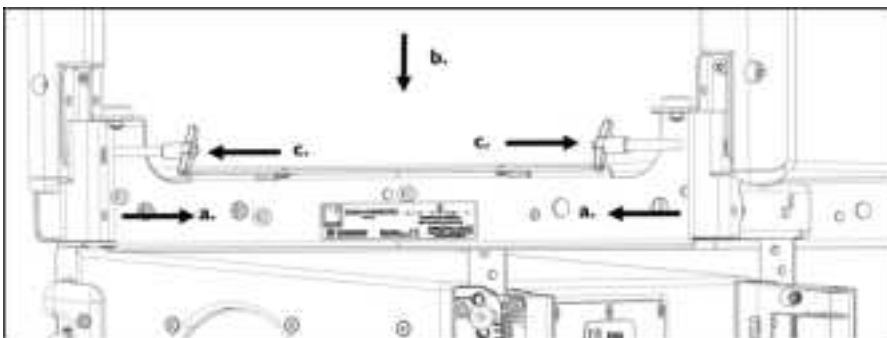

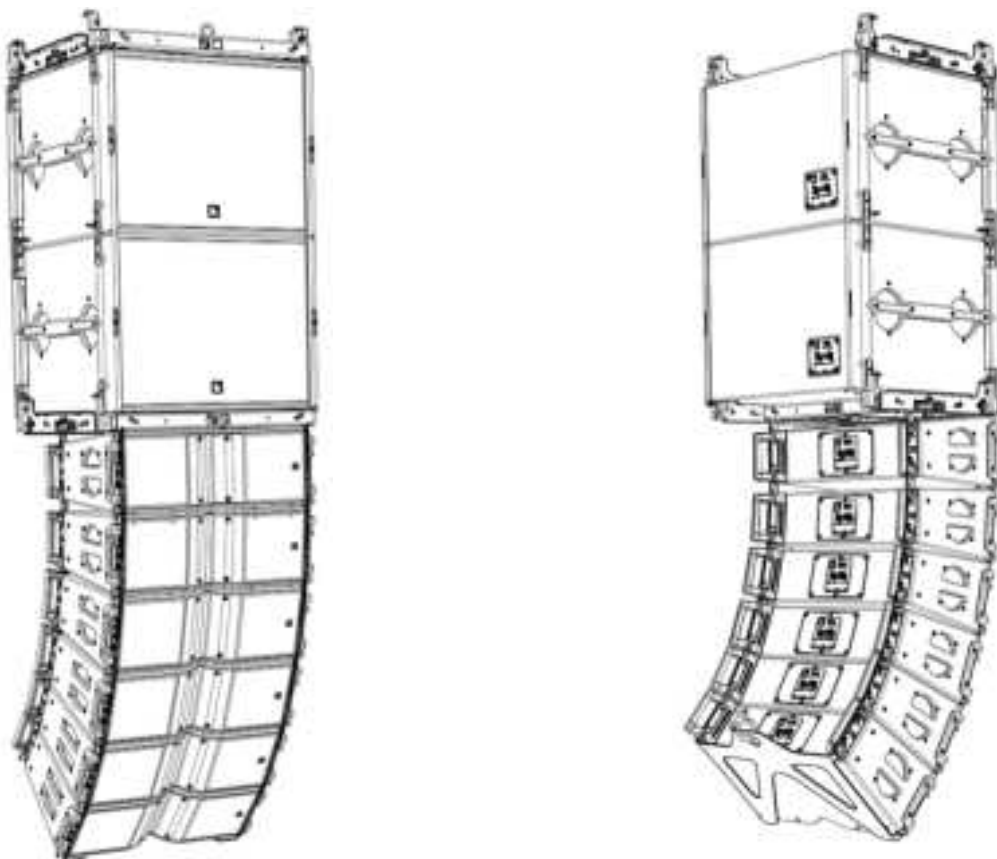

- 16.** Continue the procedure by applying the Kara II standalone array mounting procedure [Array mounting](#) (p.65), steps 7 (p.68) to 19.



Array removal

About this task

-  All along the procedure:
 Strictly follow the sequence of the successive steps.
 Systematically verify that each BLP is fully inserted.
-  For clarity purposes the loudspeaker cable removal procedure will not be described.
 The loudspeaker cables will not be represented on the figures.

Procedure

1. If the array to disassemble is an SB18 standalone array, directly go to step 8 (p.93).
 If the array to disassemble is an SB18/Kara II mixed array, begin the procedure by applying the Kara II standalone array removal procedure, steps 1 (p.71) to 12, and then continue from step 2 (p.92) below.
2. Lower ARRAY#1 into the tray. The bottom SB18 must be resting on both KARA-MINIBUEX.
3. Remove ARRAY#1 from the SB18 array as follows:
 - a) Remove the four T-BLP from the **link** holes of both KARA-MINIBUEX.
 - b) Raise the SB18 array until it is separated from ARRAY#1.
 - c) Re-insert the four T-BLP into the KARA-MINIBUEX **storage** holes.

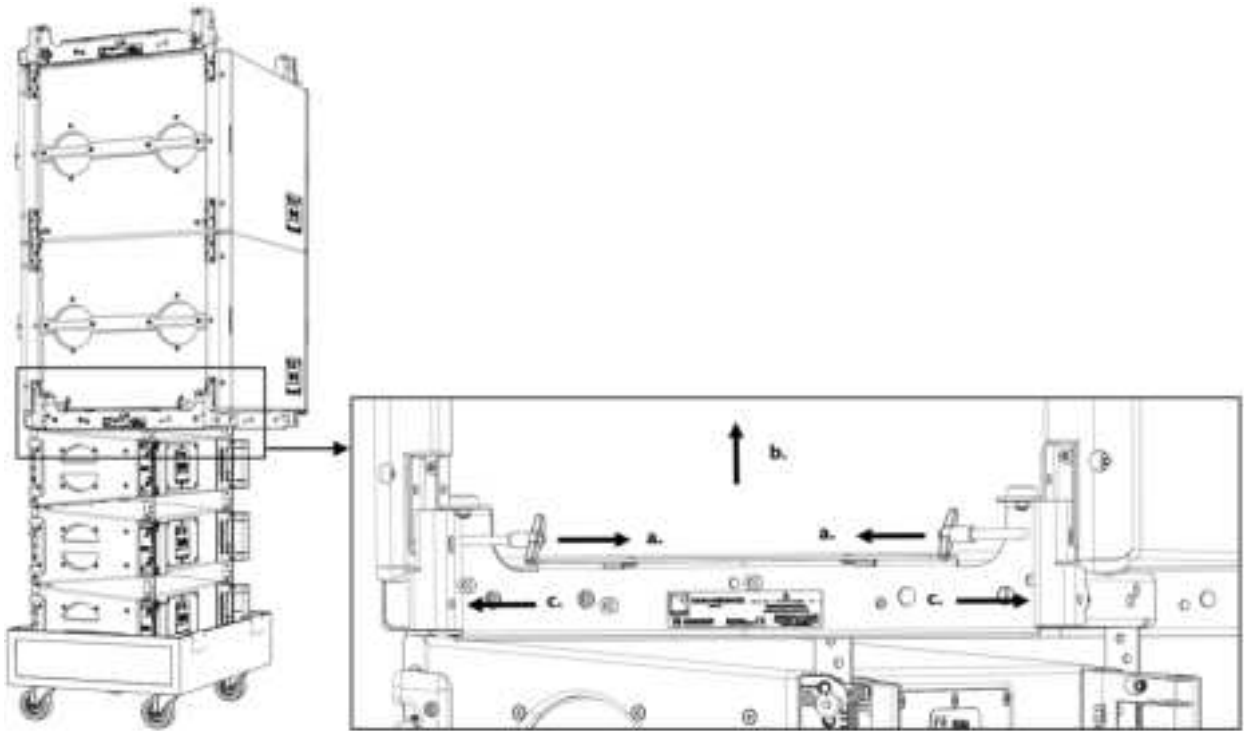

4. Remove ARRAY#1 from under the SB18 array.

5. Remove the KARA-MINIBU/KARA-MINIBUEX from KARA#1 as follows:

- a) Remove the four R-BLP from the KARA-MINIBU.
- b) Remove the KARA-MINIBU/KARA-MINIBUEX from ARRAY#1.
- c) Re-insert the four R-BLP into the same KARA-MINIBU holes.

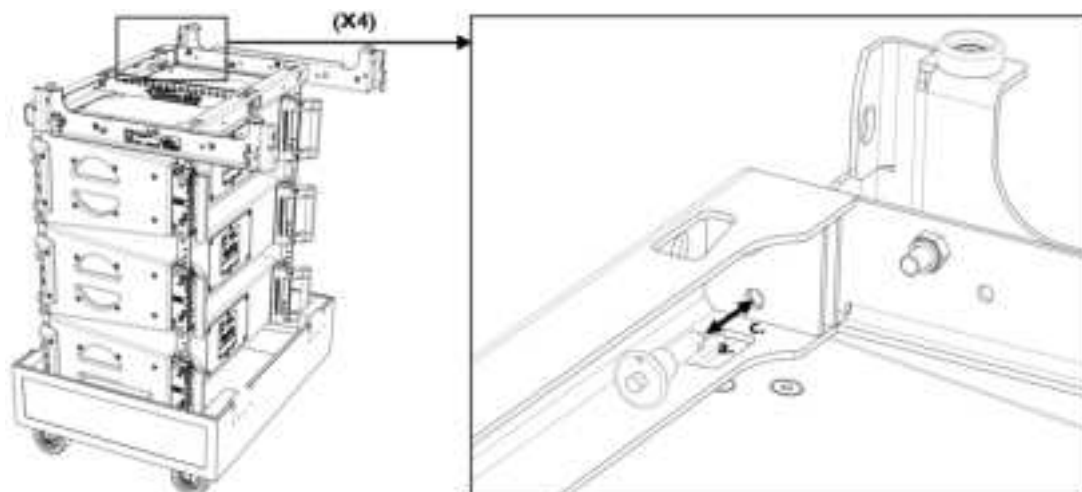

6. Close the four KARA#1 arms as follows (repeat on both sides of the enclosure):

- a) Remove the front top R-BLP from its **link** hole, slide the front arm up, rotate it down, and lock it in place by re-inserting the R-BLP into its **storage** hole.
- b) Remove the rear top R-BLP from its angle hole, slide the angle arm so as to align the cursor with the storage label, and lock it in place by re-inserting the R-BLP into its **storage** hole.

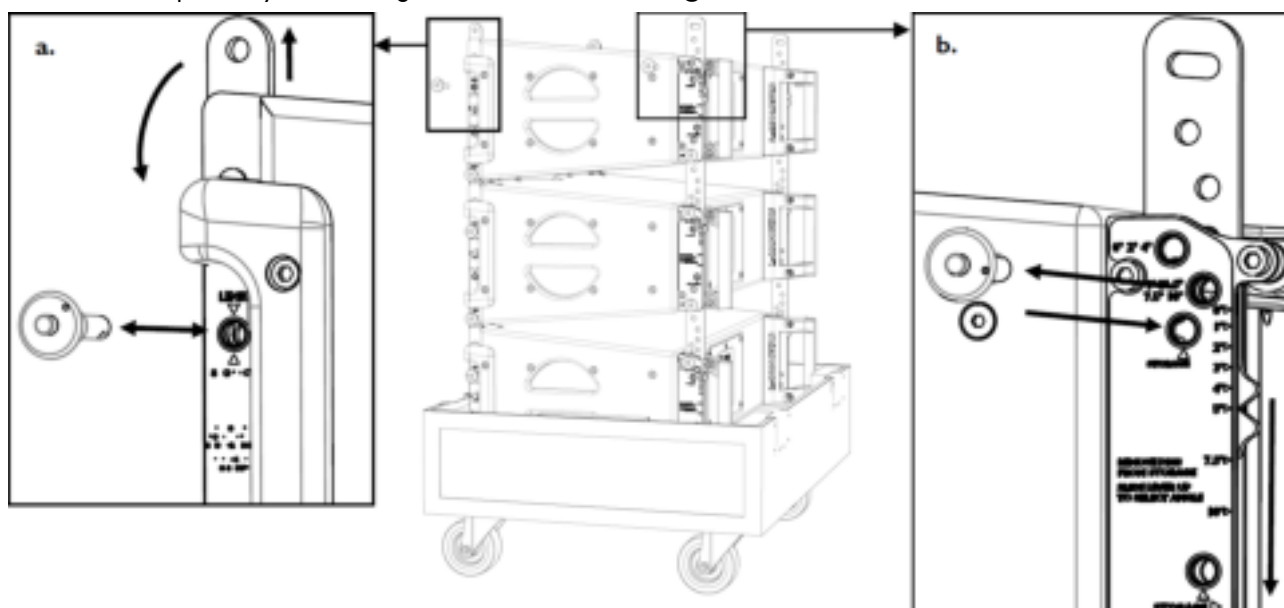

7. Attach the lid to the flight-case.



The procedure is continued with an array composed of four SB18 enclosures to cover all possible cases.

- 8.** If not already done, detach both safety slings from the KARA-MINIBU.
- 9.** Lower the array until the bottom SB18 (SB18#4 for example) rests on the ground and the SB18 above (SB18#3 for example) rests onto it.

- 10.** Remove SB18#3 from SB18#2 as follows:
- Remove a T-BLP from an SB18#2 bottom link point.
 - Rotate the link arm down.
 - Lock the link arm in closed position by re-inserting the T-BLP into SB18#3.
 - Repeat this procedure until all four arms are locked in closed position.

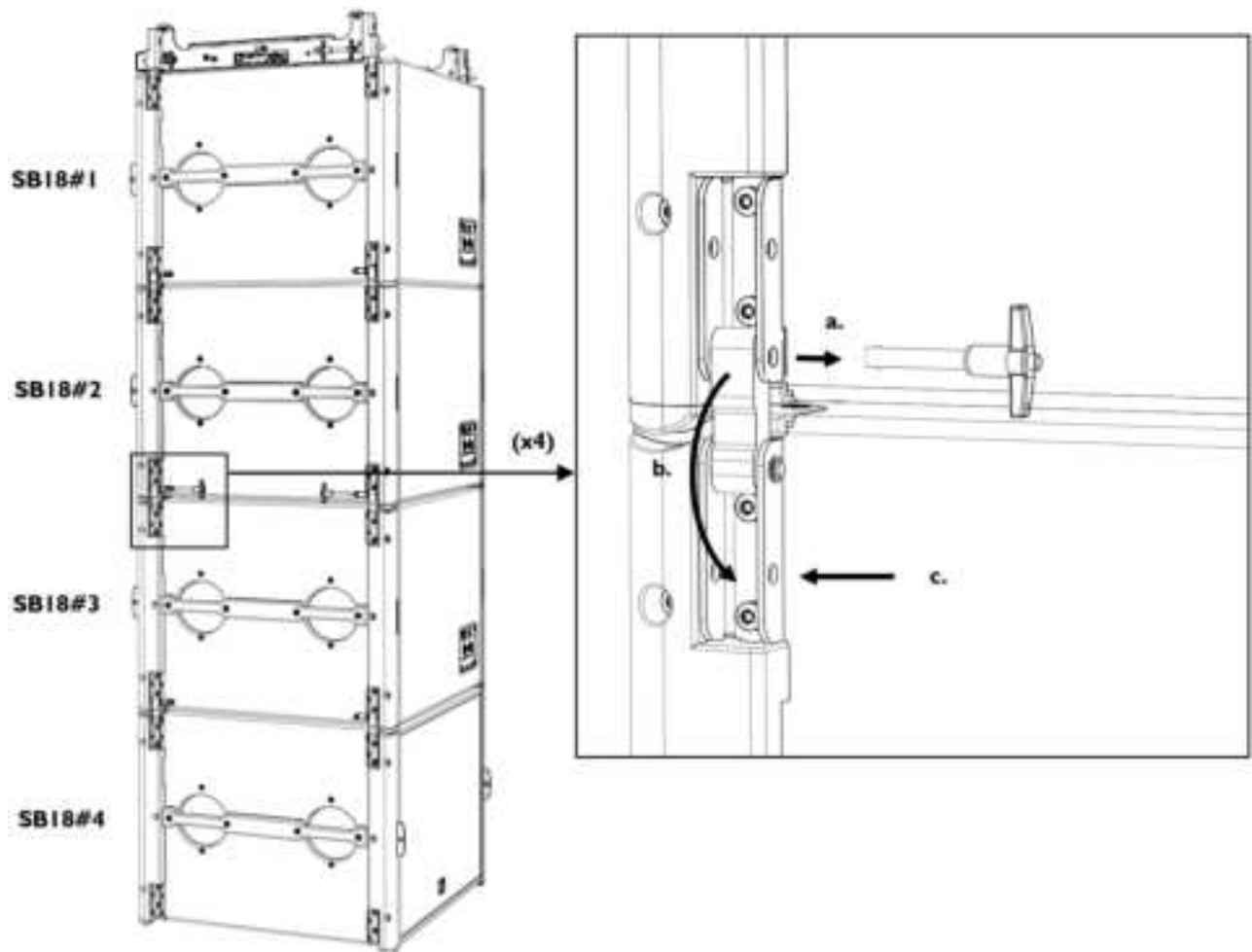

- Raise the array until SB18#2 is removed from SB18#3.
- Attach a dolly board to each of the SB18#3 and SB18#4 subwoofers.
- Remove SB18#4 from SB18#3 by applying step 10 (p.94).
- Remove SB18#3 and SB18#4 from the rigging location.
- Lower the array until it rests on the ground.
- Detach the motor hook(s) or stinger(s) from the KARA-MINIBU shackle(s).

17. Remove the KARA-MINIBU/KARA-MINIBUEX from SB18#1 as follows:

- a) Remove the four T-BLP from both KARA-MINIBUEX.
- b) Lift the KARA-MINIBU/KARA-MINIBUEX up and remove it from SB18#1.
- c) Rotate the four SB18#1 link arms down.
- d) Lock the link arms in closed position by re-inserting the four T-BLP into the top SB18#1 link points.

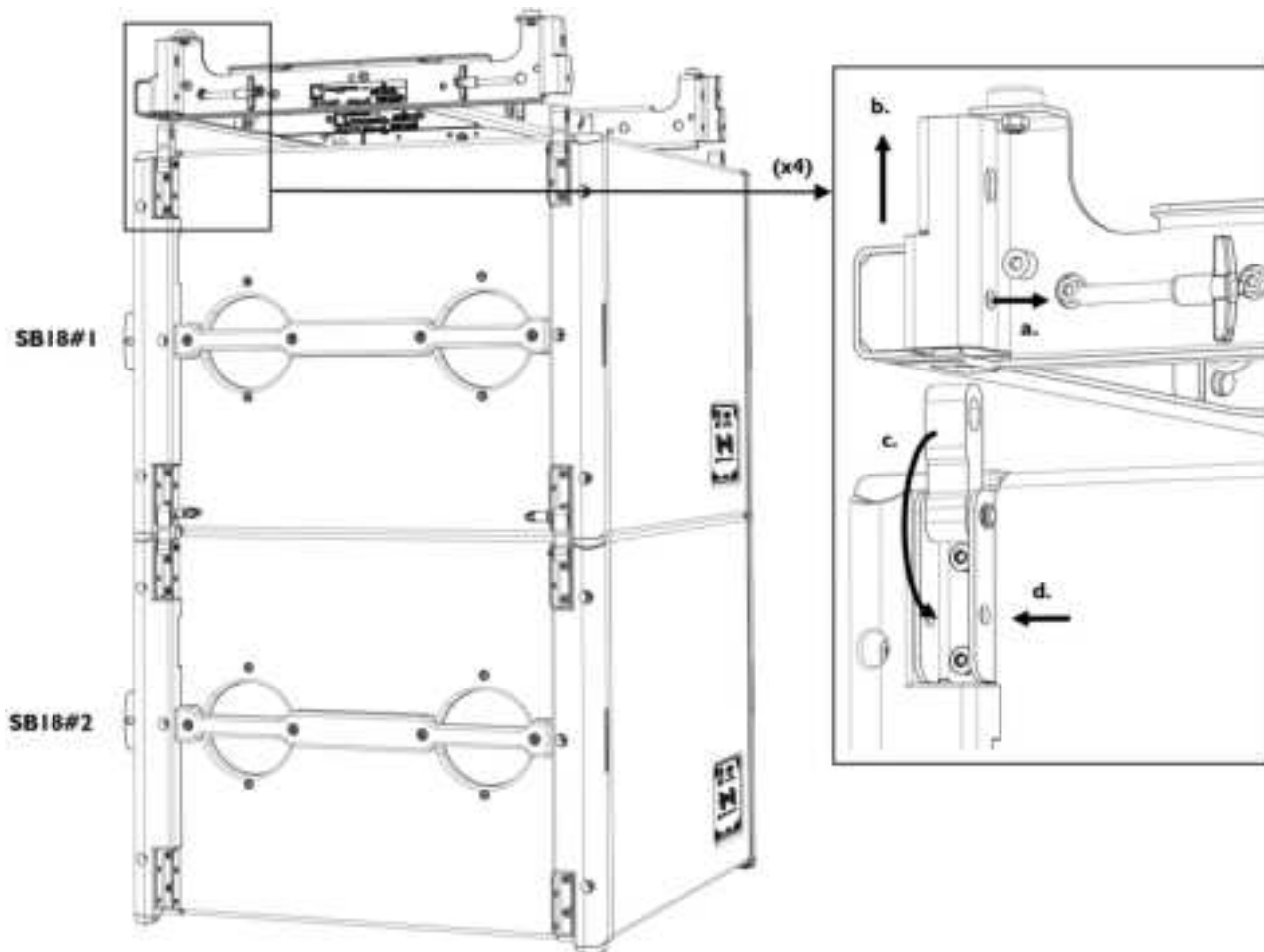

18. Attach a dolly board to each of the SB18#1 and SB18#2 subwoofers.

19. Remove SB18#2 from SB18#1 by applying step 10 (p.94) and remove both subwoofers from the rigging location.

Stacking a Kara II standalone array

Using M-BUMP

Modeling and safety

A Kara II array can be stacked onto an M-BUMP/M-BAR/M-JACK platform (platform stacked array). The platform provides tilt adjustments in case of slope surface and increases the array stability.

Any platform stacked array must be modeled before installation so as to ensure acoustical conformity. This can be done using L-Acoustics [Soundvision Software](#) which will assist the user to:

- Determine the number of required Kara II enclosures.
- Calculate the inter-enclosure angles.

- !** A platform stacked array can be composed of a maximum of 9 Kara II enclosures along with all loudspeakers cables (refer to [Mechanical safety](#) (p.31)).
- The platform must be installed in rear extension configuration if the Kara II array is intended to have a positive site angle (refer to [Stacking platform configuration](#) (p.200)).
- The platform must be installed in front extension configuration if the Kara II array is intended to have a negative site angle (refer to [Stacking platform configuration](#) (p.200)) and a flat shape (all inter-enclosure angles are close to 0°).

The Kara II and M-BUMP fully integrated rigging systems allow assembling the array with no need for any external accessory. The following first procedure describes how to mount a vertical Kara II platform stacked array. The second procedure describes how to disassemble the array.

Array mounting

About this task

- !** All along the procedure:
- Strictly follow the sequence of the successive steps.
 - Systematically verify that each BLP is fully inserted.
 - Systematically verify that each bolt is fully screwed in and secured with pin.
- !** For clarity purposes the loudspeaker cabling procedure will not be described.
- The loudspeaker cables will not be represented on the figures.

Procedure

1. Place an M-BUMP at the rigging location. Turn it so that the text of the identification plate is upside down and the laser slits are directed towards the audience.

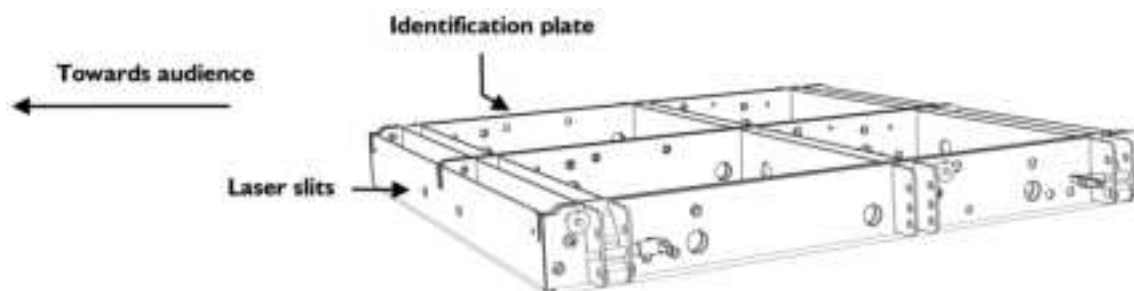

2. Mount two M-BAR/M-JACK assemblies as follows (repeat for each M-BAR):

- a) Remove the axis and safety pin from M-JACK.

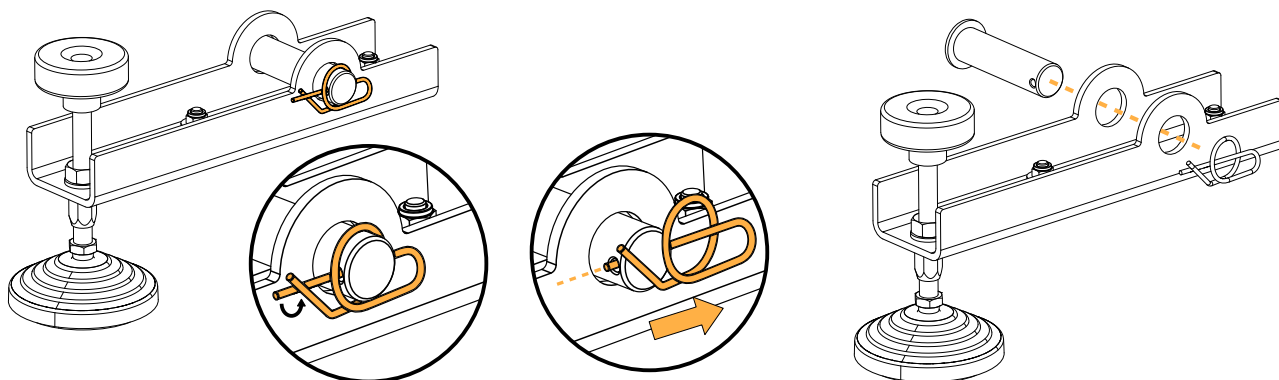

- b) Place an M-JACK under one end of an M-BAR and align the M-JACK hole with the second M-BAR hole.

- c) Secure M-JACK to M-BAR with the axis and safety pin.

Lock the safety pin.

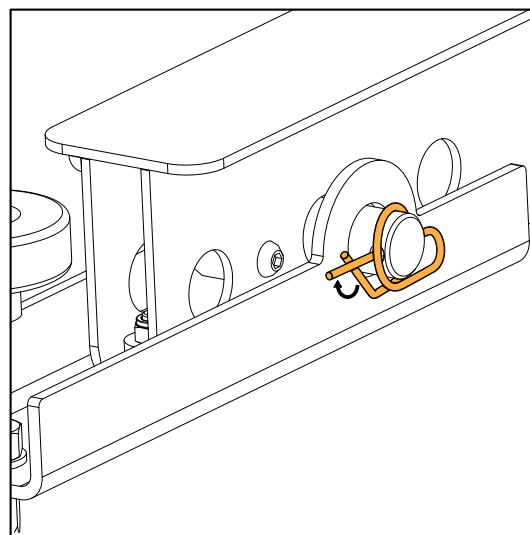
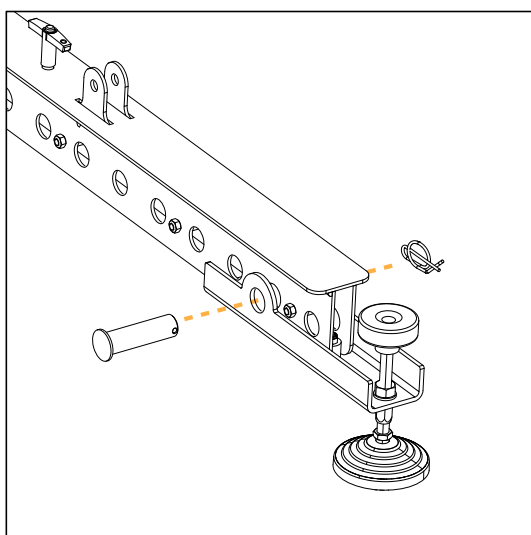

- d) Repeat the procedure to attach a second M-JACK to the other end of the M-BAR.

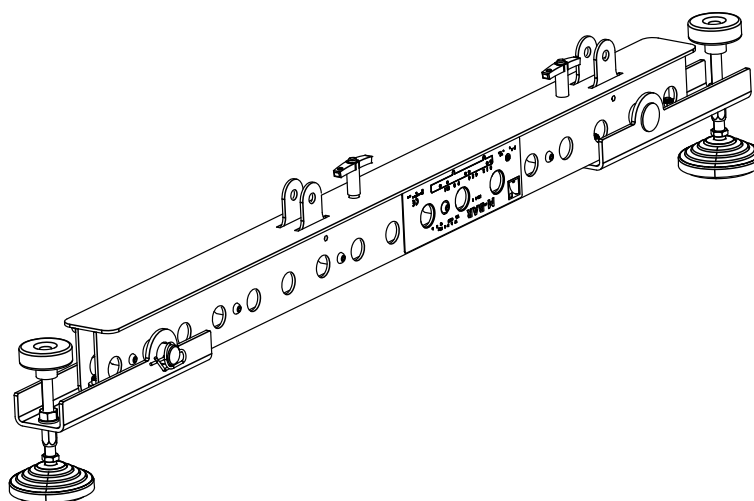

3. According to the chosen configuration (see [Stacking platform configuration](#) (p.200)), mount the stacking platform as follows (repeat for each M-BAR):
 - a) Remove both T-BLP from an M-BAR.
 - b) Lift up one side of the M-BUMP, place the M-BAR beneath it with M-JACK on the ground, and lower the M-BUMP so as to insert both M-BAR studs into the M-BUMP slits.
 - c) Secure by inserting both preceding T-BLP.

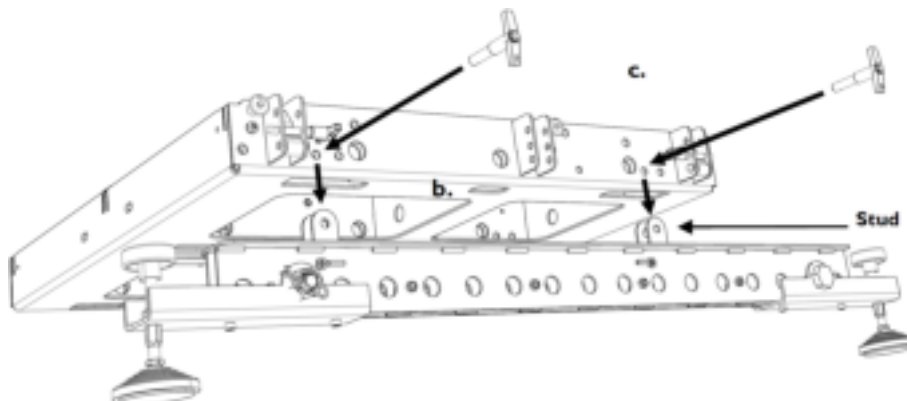

4. Adjust the stacking platform in horizontal position by setting the heights of the 4 M-JACK as follows:
 - a) Unscrew the locking nut on each M-JACK (16 mm hex key).
 - b) Place an inclinometer device onto the platform in the direction parallel to the M-BAR and rotate the 4 M-JACK knobs to adjust the platform in the horizontal position.

i The inclinometer can be mounted to the integrated laser plate (see [Installing an inclinometer](#) (p.192)).

i In case of high resistance the user can also screw the base nut (14 mm hex key) in place of a knob.

- c) Put an inclinometer device in the direction perpendicular to the M-BAR and verify that the platform is also horizontal in this direction.

i The handheld inclinometer included in the **TECH TOOLCASE** can be used in this step.

- d) Lock each M-JACK height by firmly screwing in the locking nut (16 mm hex key).

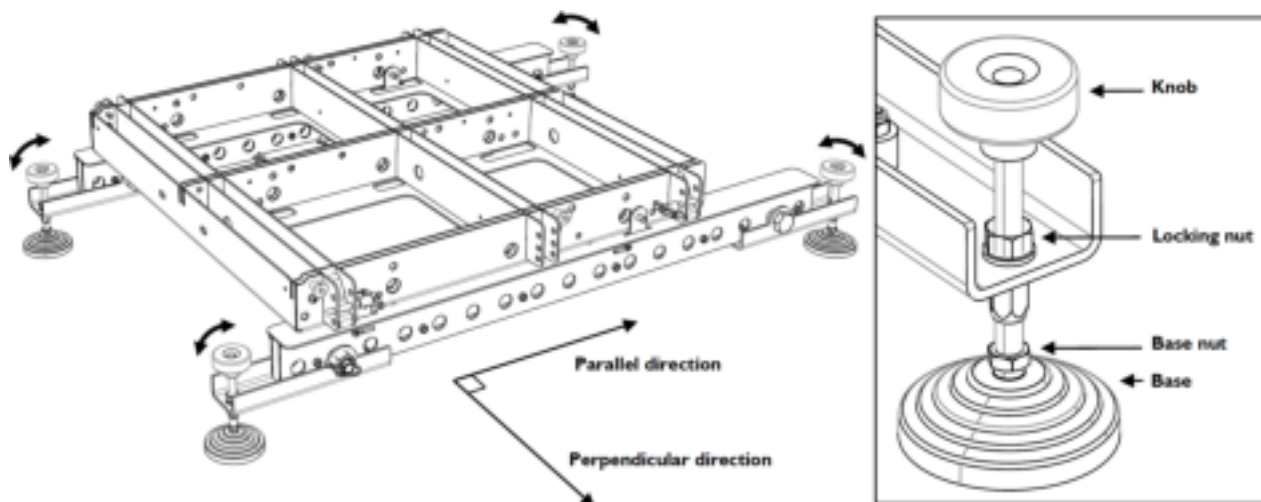

5. (Optional, see [Array site angle setting](#) (p.201)) Mount both KARA-ANGARMEX to the M-BUMP as follows (repeat for each one):
 - a) Remove the storage T-BLP and the rear R-BLP.
 - b) Insert the single part of the KARA-ANGARMEX into the M-BUMP by putting it vertically with sling ring pointing towards the front and indentation on the spacer.
 - c) Align the KARA-ANGARMEX and M-BUMP holes. Insert the R-BLP.

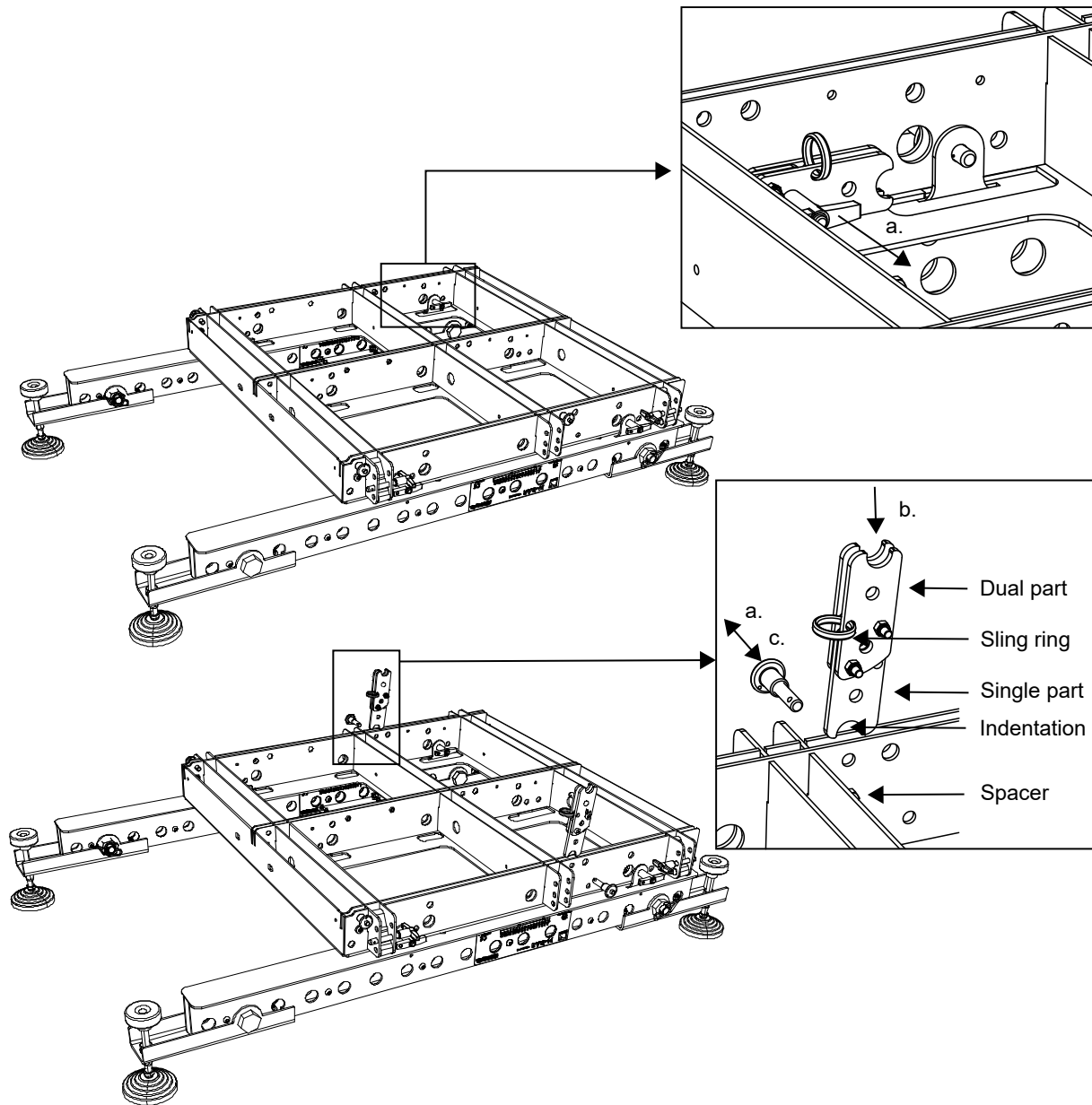

6. Remove both front R-BLP from the M-BUMP. If the M-BUMP has been configured without KARA-ANGARMEX, also remove both rear R-BLP.
7. Place a full Kara II flight-case at the stacking location and remove the lid. In the following, the enclosures will be designated as KARA#1 to KARA#3 from top to bottom.
8. Set KARA#1 in stacking configuration as follows (repeat for each side):
 - a) Remove the front top R-BLP from its storage hole, rotate the front arm up, slide it down, and secure by reinserting the R-BLP into the top yellow link hole.
 - b) Remove the rear top R-BLP from its storage hole, slide the angle arm so as to align the cursor with the chosen angle value, and secure by re-inserting the R-BLP into the corresponding angle hole (0°/2°/4° or

1°/3°/5°/7.5°/10°). Refer to [Array site angle setting](#) (p.201) for equivalence between the chosen angle value and the array site angle.



Risk of blocked ball-locking pin.

Be careful not to trap the ball-locking pin tether between the rigging arm and the side handle.

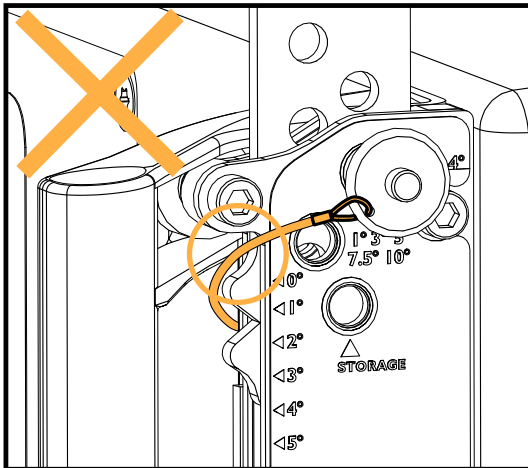

c) Remove the front and rear bottom link R-BLP and re-insert them into the bottom storage holes.

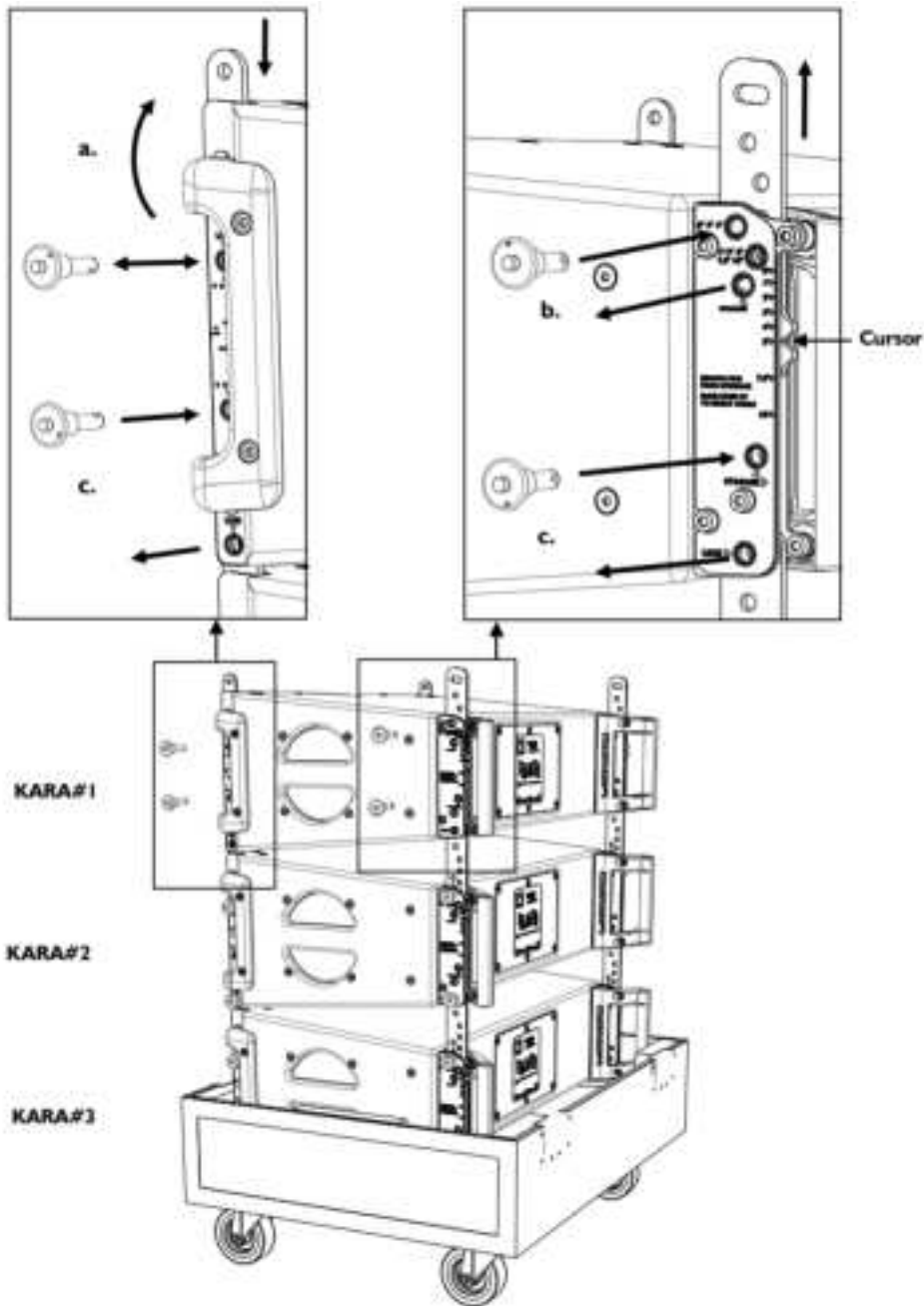

9. Link KARA#1 to the M-BUMP as follows:

- Lift up KARA#1 and turn it arms downwards and front face towards the audience.
- Insert the four arms into the M-BUMP rigging points. If the M-BUMP has been configured with KARA-ANGARMEX, the rear rigging points become those of the KARA-ANGARMEX.
- Secure both front rigging points by inserting the R-BLP into the M-BUMP. Depending on the configuration, secure both rear rigging points by inserting either both R-BLP into the M-BUMP or both T-BLP into the KARA-ANGARMEX.

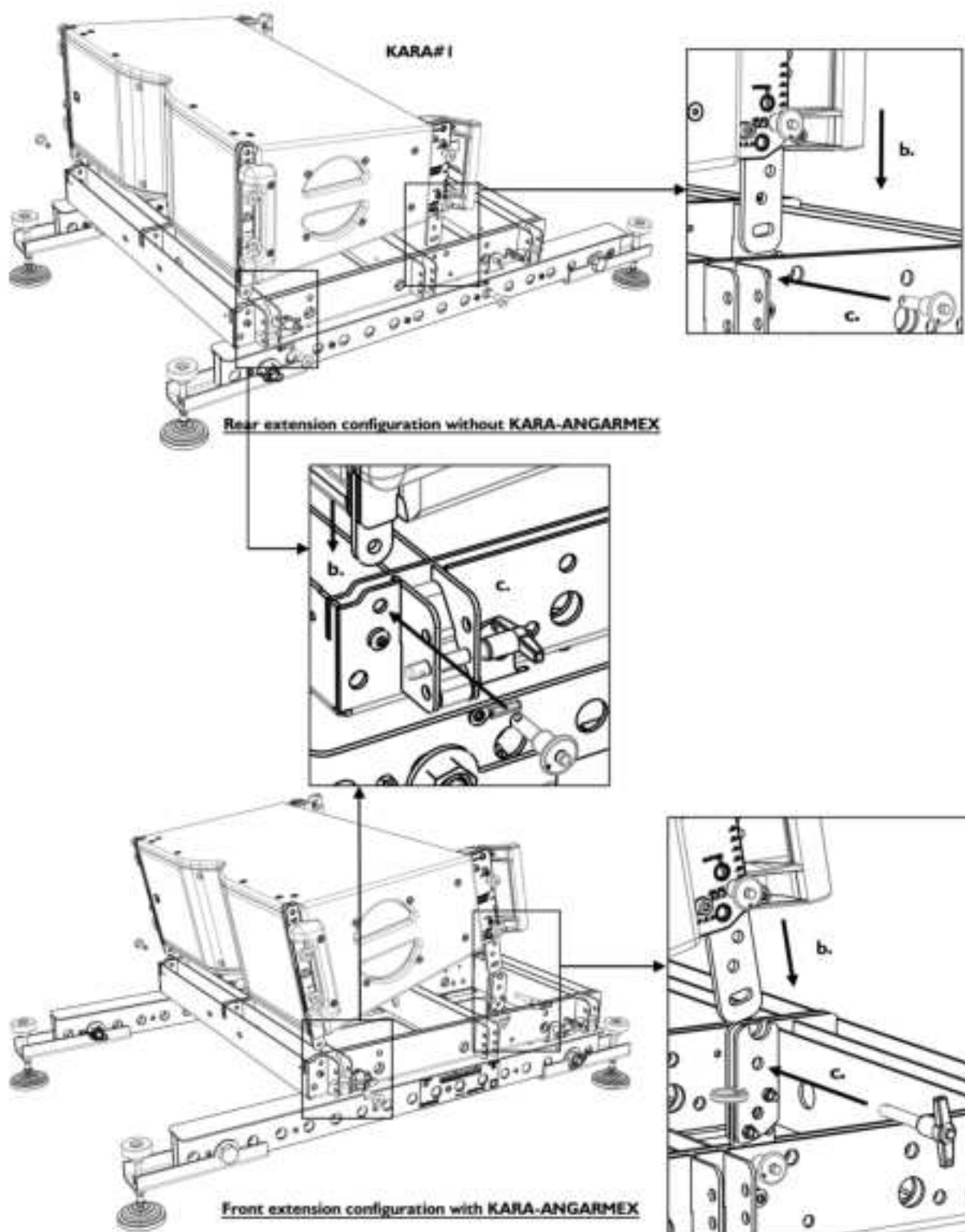

10. Set KARA#2 in rigging configuration by applying step 8 (p.99).

11. Link KARA#2 to KARA#1 as follows:

- a) Put KARA#2 upside down and direct the front grill towards the audience.
- b) Insert the four arms into the KARA#1 rigging points.
- c) Secure the four rigging points by removing the four KARA#1 top R-BLP from their storage holes and reinserting them into the top yellow link holes.

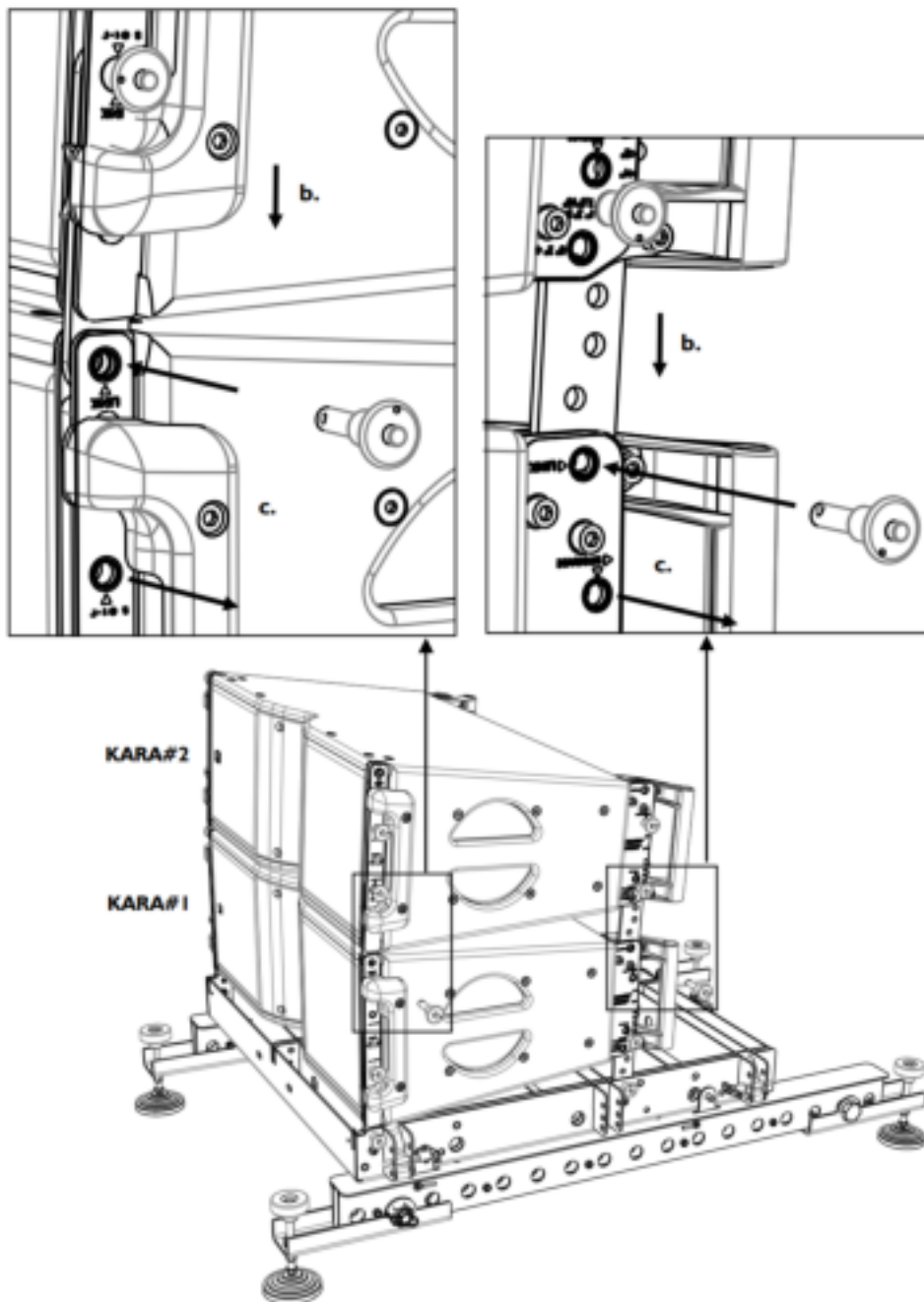

12. Link KARA#3 to KARA#2 by applying steps 10 and 11 (do not remove the 4 bottom R-BLP from KARA#3).

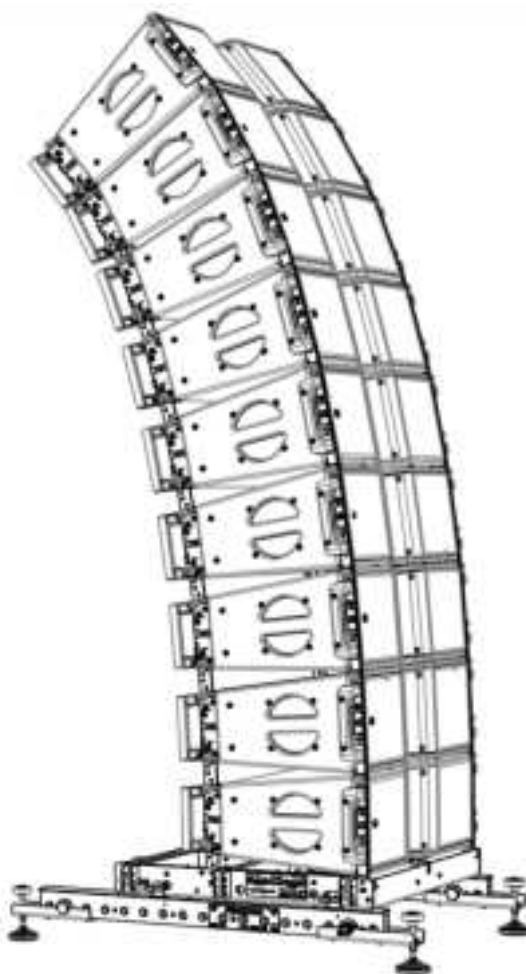

- 13.** Using other full Kara II flight-cases, repeat steps 10 (p.101) and 11 (p.102) until all Kara II enclosures composing the array are rigged.



- 14.** Check if the stacking platform is still horizontal. If not, refer to step 4 (p.98).
- 15.** Secure the system to a fixed point using a ratchet strap or any other applicable material (not included).

Array removal

About this task

-  All along the procedure:
Strictly follow the sequence of the successive steps.
Systematically verify that each BLP is fully inserted.
-  For clarity purposes the loudspeaker cable removal procedure will not be described.
The loudspeaker cables will not be represented on the figures.

Procedure

1. Remove the ratchet strap from the array.
2. Place an empty Kara II flight-case at the rigging location and remove the lid.
3. Separate the top Kara II (KARA#3 for example) from the Kara II below (KARA#2 for example) as follows: remove the 4 top link R-BLP from KARA#2 and re-insert them into the top storage holes.

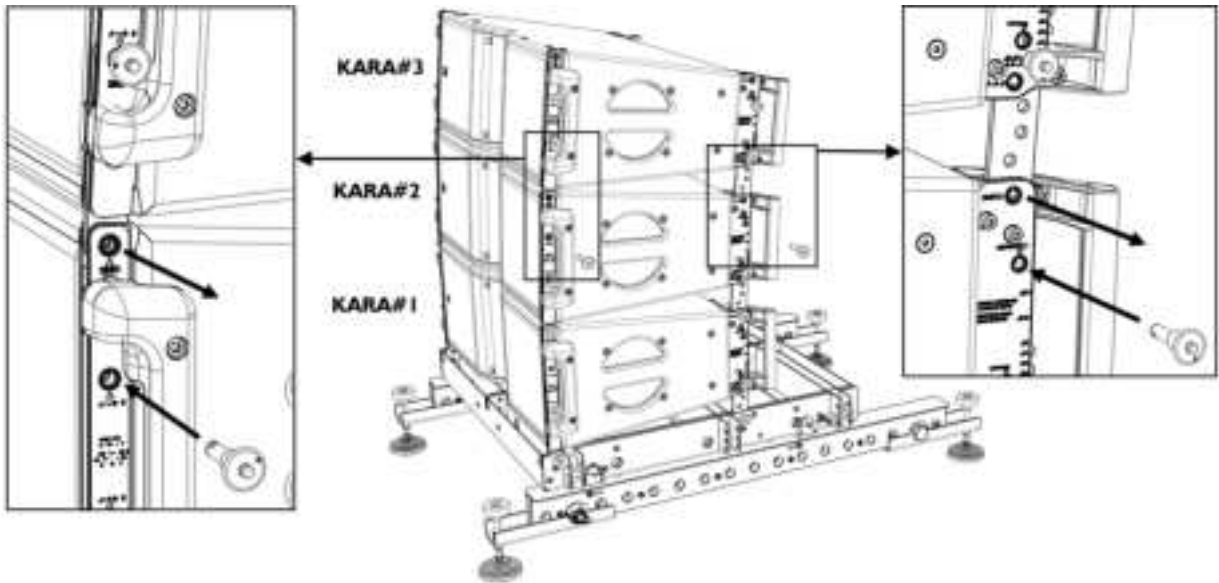

4. Lift up and turn KARA#3 arms upwards. Put KARA#3 into the flight-case tray.

-  Pay attention to the tray position: both wedges must slope upwards from front to rear (refer to [Flight-case](#) (p.30)).

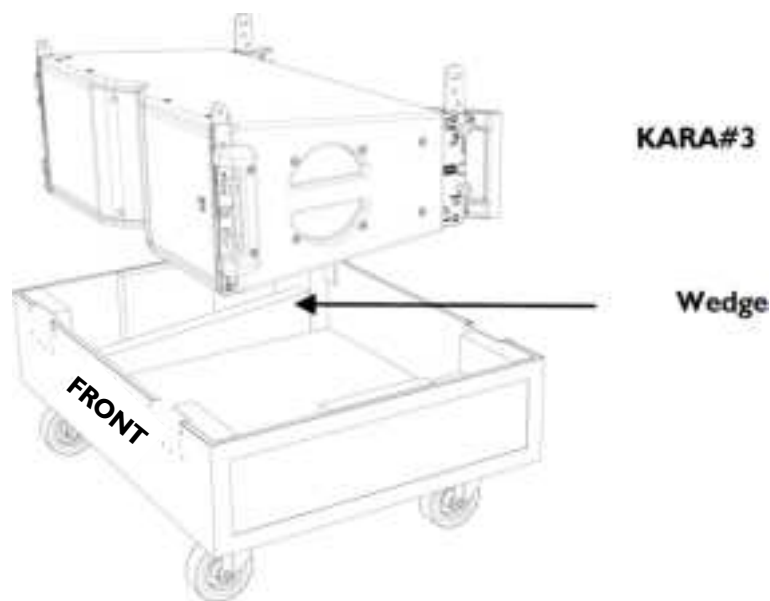

- 5.** Set the angle to 0° on KARA#3 as follows (repeat for each side): remove the rear top angle R-BLP, slide the angle arm so as to align the cursor with the 0° angle value, and secure by re-inserting the R-BLP into angle hole $0^\circ/2^\circ/4^\circ$.

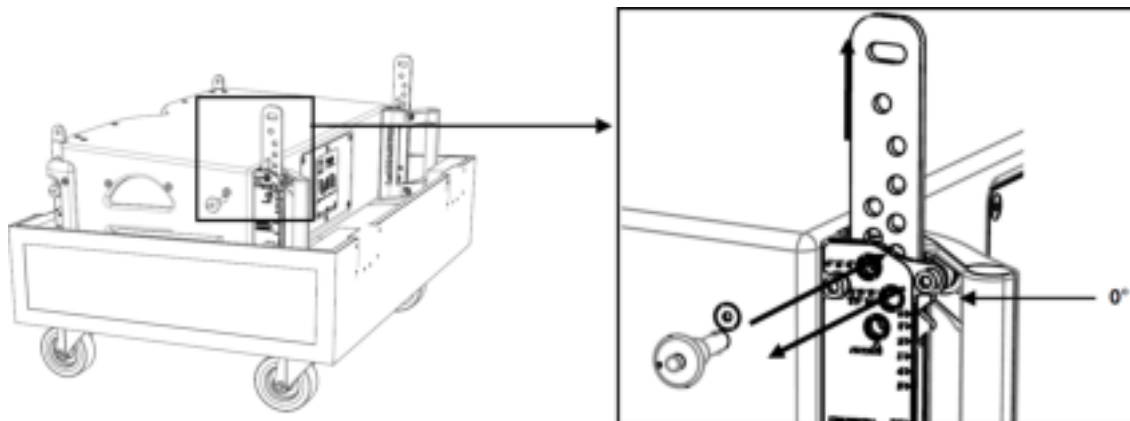

- 6.** Separate KARA#2 from KARA#1 by applying step 3 (p.104).
7. Lift up and turn KARA#2 arms upwards. Connect KARA#2 to KARA#3 (with two grills on the same side) by aligning the 4 rigging points between both enclosures. Remove the 4 R-BLP from the bottom storage holes of KARA#2 and secure by re-inserting them into the bottom yellow link holes.

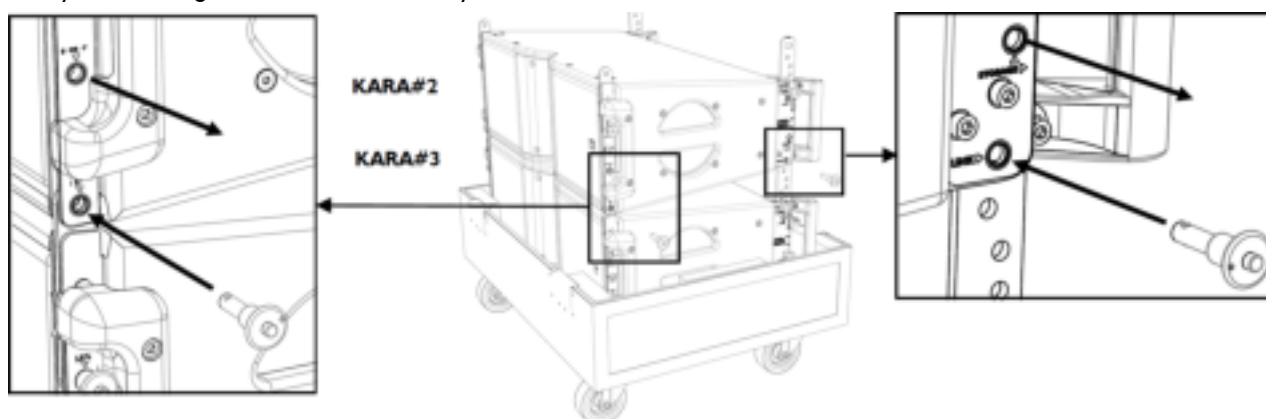

- 8.** Set the angles to 0° on KARA#2 by applying step 5 (p.105).

- 9.** Separate KARA#1 from the M-BUMP as follows (or repeat the procedure from step 3 (p.104) if the top enclosure is not KARA#1):
- Remove both front R-BLP from the M-BUMP.
 - Depending on the configuration, remove either both rear R-BLP from the M-BUMP or both T-BLP from the KARA-ANGARMEX.

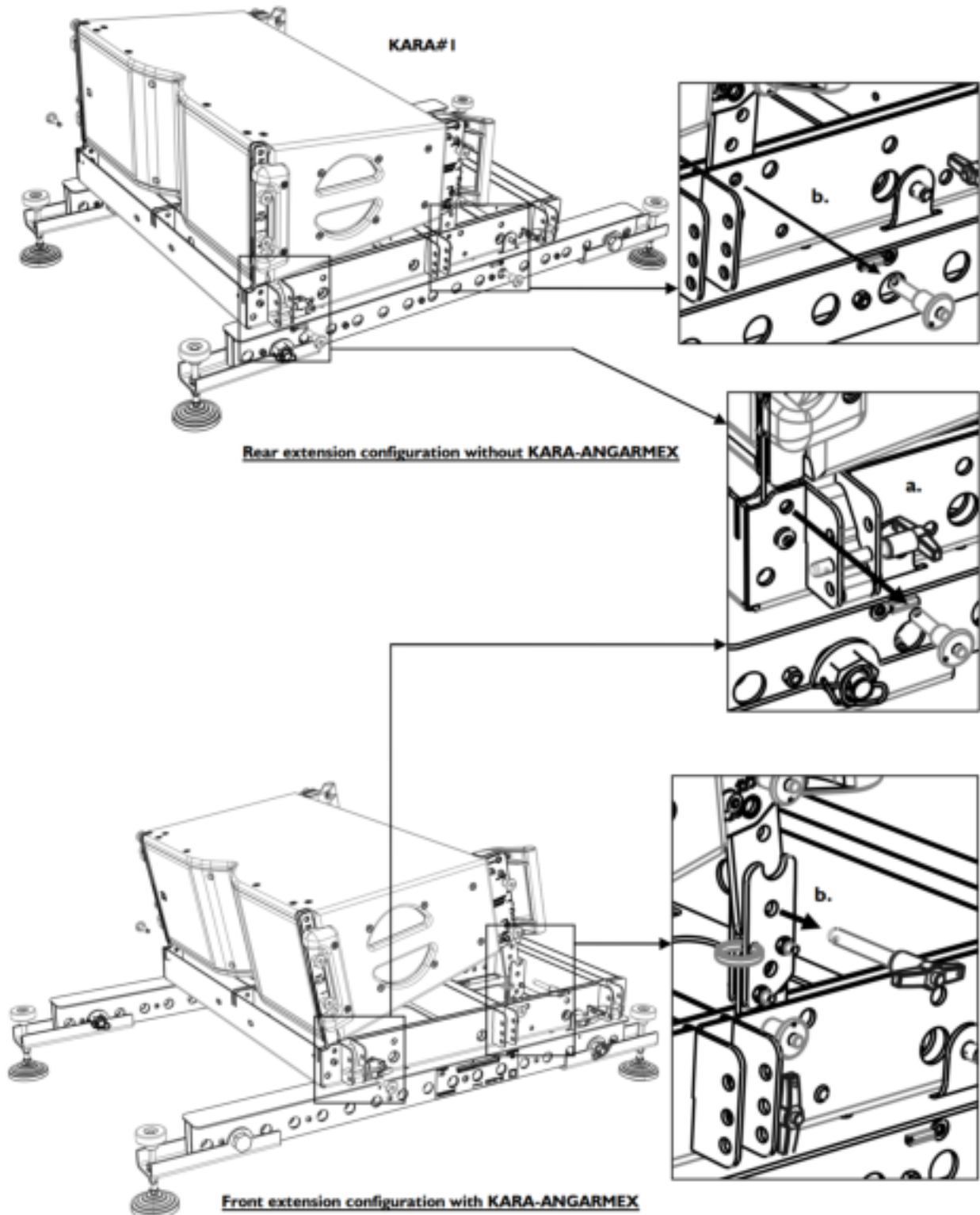

- 10.** Attach KARA#1 to KARA#2 by applying step 7 (p.105).

11. Set the KARA#1-3 array for transport as follows:

- a) On both sides of KARA#1, remove the front top link R-BLP, slide the front arm up, rotate down, and secure by re-inserting the R-BLP on the top storage hole.
- b) On both sides of KARA#1, remove the rear top R-BLP, slide the angle arm so as to align the cursor with the storage position, and secure by re-inserting the top R-BLP on the top storage hole.
- c) Put the flight-case lid back in place.

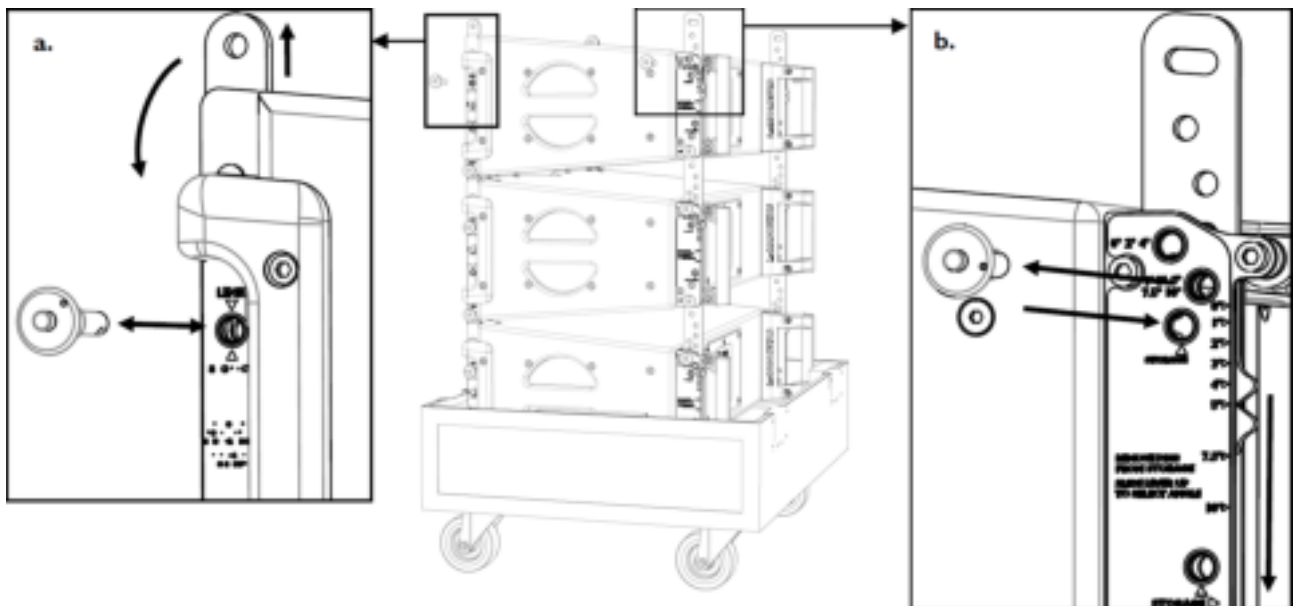

12. Repeat steps 2 (p.104) to 11 until all Kara II enclosures are removed.

13. (Optional) On the M-BUMP, put both KARA-ANGARMEX in storage position as follows (repeat for each one):

- a) Remove the rear R-BLP, remove the KARA-ANGARMEX, and re-insert the R-BLP into the M-BUMP hole.
- b) Put the KARA-ANGARMEX horizontally in its storage location and secure by inserting the T-BLP.

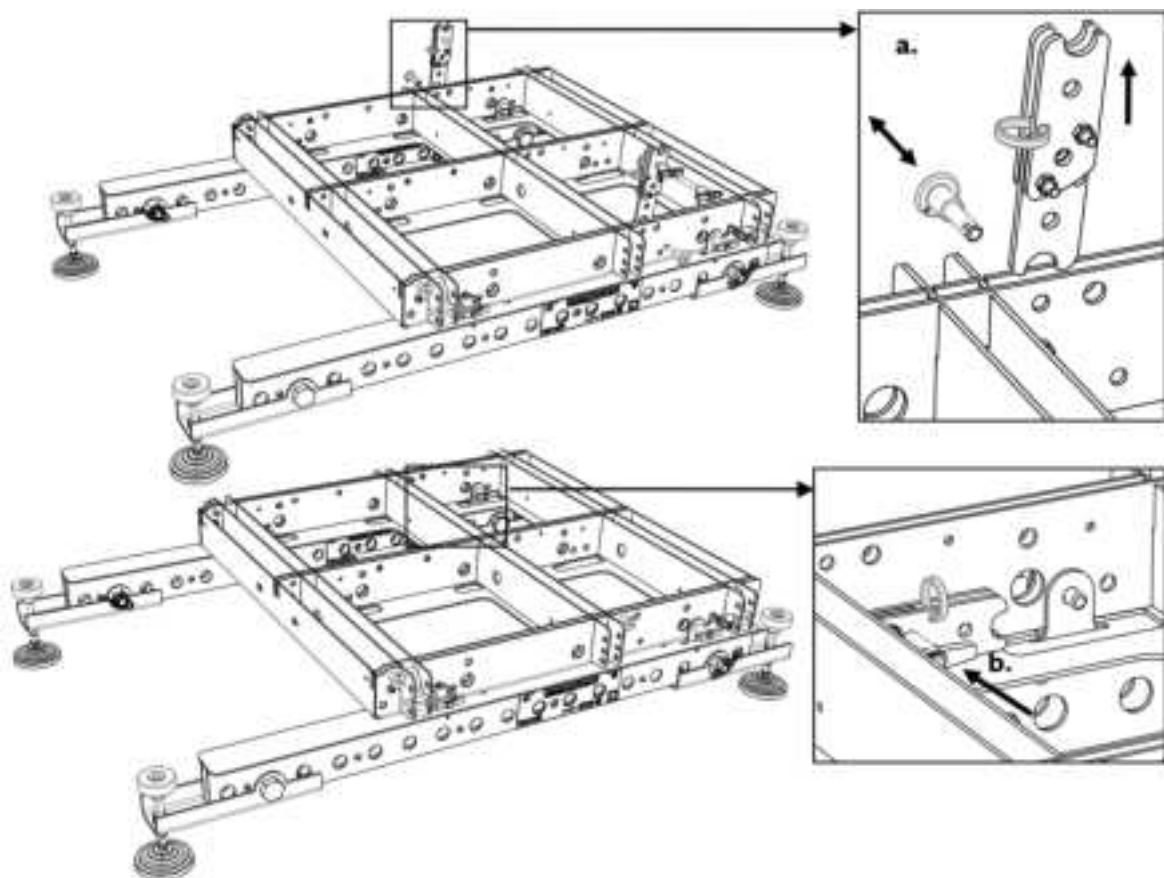

14. Remove both M-BAR/M-JACK assemblies from the M-BUMP as follows (repeat for each one):

- a) Remove both T-BLP from the M-BAR studs.
- b) Lift up the corresponding side of the M-BUMP and remove the M-BAR.
- c) Re-insert both T-BLP into their storage holes.

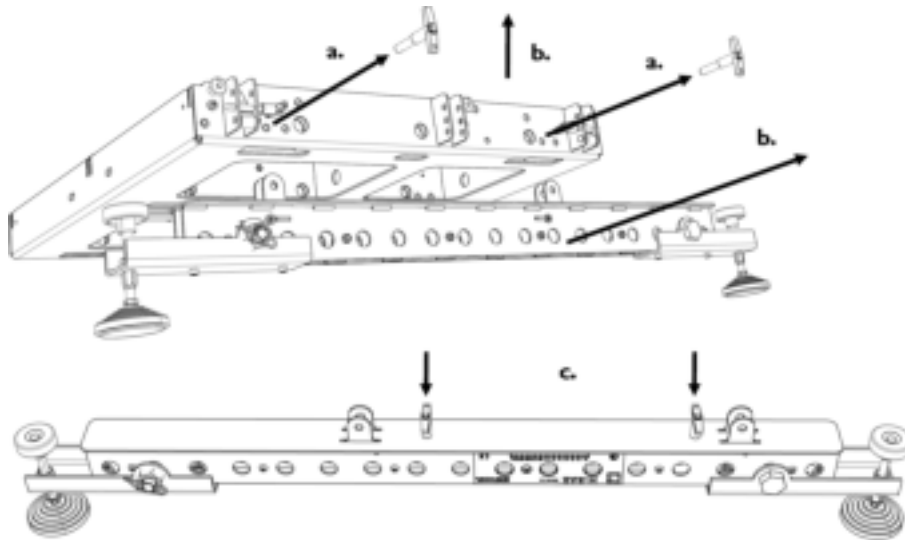

15. Remove both M-JACK from each M-BAR.

On each M-JACK, unlock the safety pin and remove the safety pin and the axis.

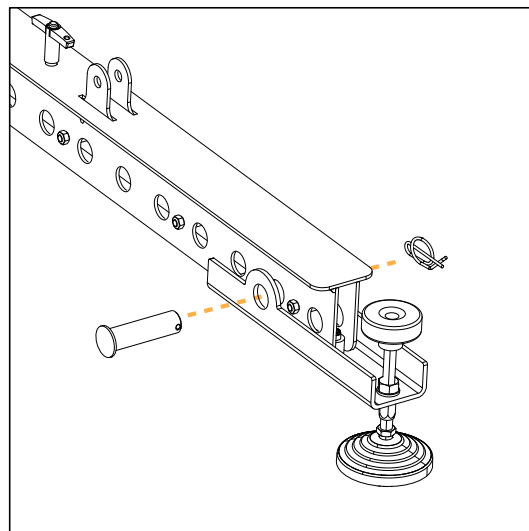
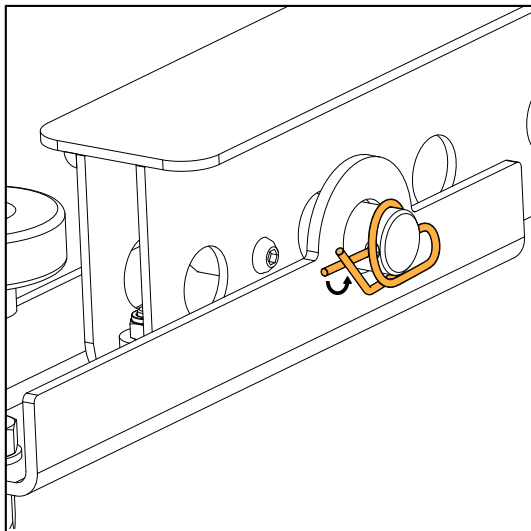

Using KARA-MINIBU

Modeling and safety

A Kara II array can be stacked onto a KARA-MINIBU/KARA-MINIBUEX platform (platform stacked array).

Any platform stacked array must be modeled before installation so as to ensure acoustical conformity. This can be done using L-Acoustics [Soundvision Software](#) which will assist the user to:

- Determine the number of required Kara II enclosures.
- Calculate the inter-enclosure angles.

 A platform stacked array requires to be installed on a perfectly horizontal and regular surface. It can be composed of a maximum of 6 Kara II enclosures along with all loudspeaker cables (refer to [Mechanical safety](#) (p.31)) within the following setup safety limits:

- If the Kara II array is flat (all inter-enclosure angles are close to 0°), the platform must be installed in front extension configuration (refer to [Stacking platform configuration](#) (p.202)) and the site angle of the bottom Kara II must be set within the range given in the table below (refer to [Array site angle setting](#) (p.203) for angle settings):

Platform stacked Kara II array safe configurations

Number of Kara II	Bottom Kara II authorized angle range
1 - 3	From -15° to +5°
4	From -11° to +5°
5 - 6	From -7.5° to +5°

- If the Kara II array is strongly curved (all inter-enclosure angles are close to 10°), the platform must be installed in rear extension configuration (refer to [Stacking platform configuration](#) (p.202)).

The Kara II, KARA-MINIBU, and KARA-MINIBUEX fully integrated rigging systems allow assembling the array with no need for any external accessory. The following first procedure describes how to assemble a vertical Kara II platform stacked array. The second procedure describes how to disassemble the array.

Array mounting

About this task

 All along the procedure:
 Strictly follow the sequence of the successive steps.
 Systematically verify that each BLP is fully inserted.
 Systematically verify that each bolt is fully driven on the KARA-MINIBUEX.

 For clarity purposes the loudspeaker cabling procedure will not be described.
 The loudspeaker cables will not be represented on the figures.

Required tools

- electric screwdriver with torque selector
- 6 mm hex bit 6 mm hex bit
- 13 mm hex key

Procedure

1. Assemble a KARA-MINIBU/KARA-MINIBUEX stacking platform as follows:
 - a) Turn the KARA-MINIBU so that the text of the identification plate is upside down.
 - b) Position a first KARA-MINIBUEX on the laser plate side of the KARA-MINIBU by turning the KARAMINIBUEX feet pointing down and inserting the stud into the slit of the KARA-MINIBU located near the laser plate.
 - c) Drive 3 bolts to the 3 holes shown in the figure below (6 mm hex bit, 13 mm hex key, 7 N.m/63 in.lb f).
 - d) Repeat the procedure with a second KARA-MINIBUEX on the other side of the KARA-MINIBU.

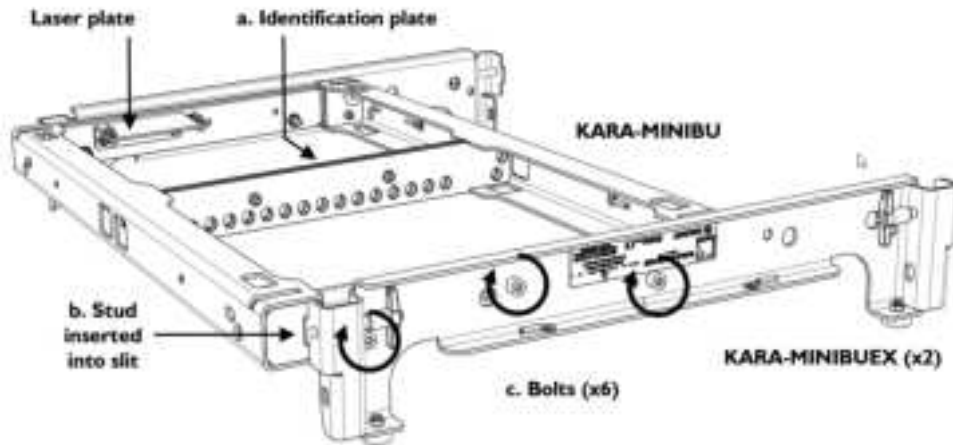

2. If KARA-ANGARMEX are intended to be used (see [Array site angle setting](#) (p.203)), attach two KARA-ANGARMEX to the platform as follows:
 - a) Remove an R-BLP from a rear corner of the KARA-MINIBU.

! When using KARA-ANGARMEX the platform must be put in front extension configuration (see [Stacking platform configuration](#) (p.202)).

- b) Insert the single part of a first KARA-ANGARMEX into the corner slit: position it vertically with sling ring towards the front and indentation resting on the spacer.
 - c) Align the KARA-ANGARMEX and KARA-MINIBU holes and secure them together by re-inserting the R-BLP.
 - d) Repeat the procedure with a second KARA-ANGARMEX on the other rear corner of the KARA-MINIBU.

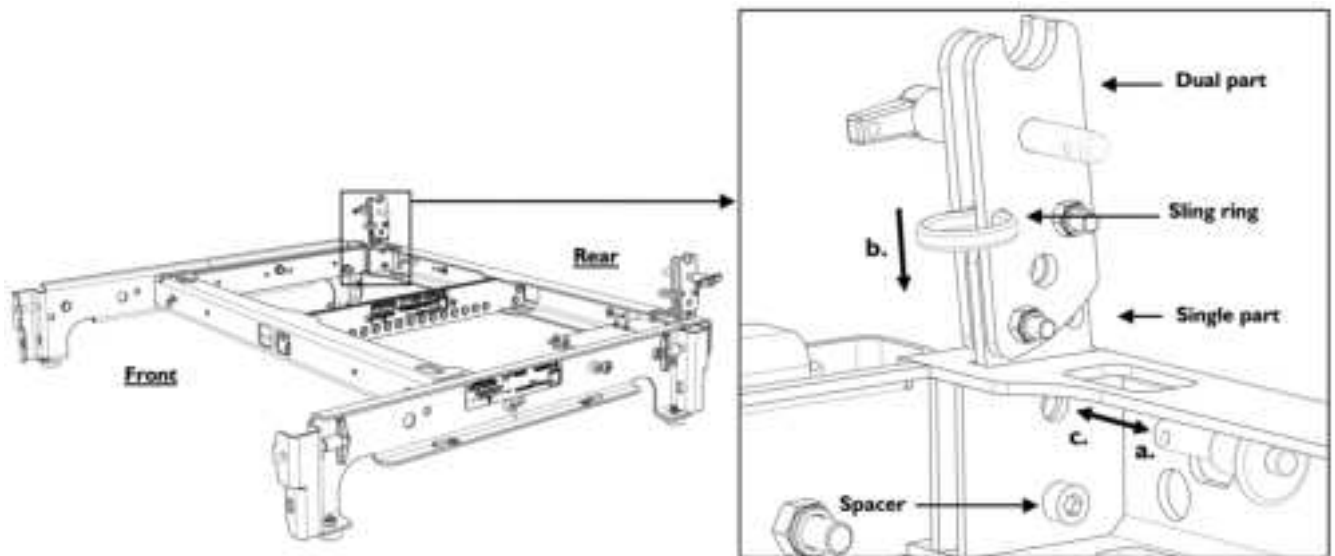

3. Remove both front R-BLP from the KARA-MINIBU.

i The front and rear sides are defined according to the chosen configuration.

4. If KARA-ANGARMEX are attached to the KARA-MINIBU, remove both T-BLP from them. Otherwise, remove both rear R-BLP from the KARA-MINIBU.
5. Bring a full Kara II flight-case to the stacking location and remove the lid. In the following, the enclosures will be designated as KARA#1 to KARA#3 from top to bottom.

6. Open the four KARA#1 arms as follows (repeat on both sides of the enclosure):

- a) Remove the front top R-BLP from its **storage** hole, rotate the front arm up, slide it down, and lock it in place by re-inserting the R-BLP into its **link** hole.



A **link** hole is indicated by a yellow circle.



The front top **storage** and **link** holes are the same.

- b) Remove the rear top R-BLP from its **storage** hole, slide the angle arm so as to align the cursor with the chosen angle label, and lock it in place by re-inserting the R-BLP into the corresponding angle hole (0°/2°/4° or 1°/3°/5°/7.5°/10°).



Risk of blocked ball-locking pin.

Be careful not to trap the ball-locking pin tether between the rigging arm and the side handle.

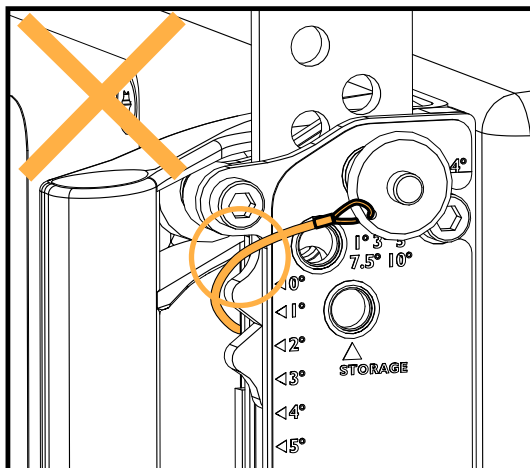

i Refer to [Array site angle setting](#) (p.203) to obtain the angle value corresponding to the chosen array site angle.

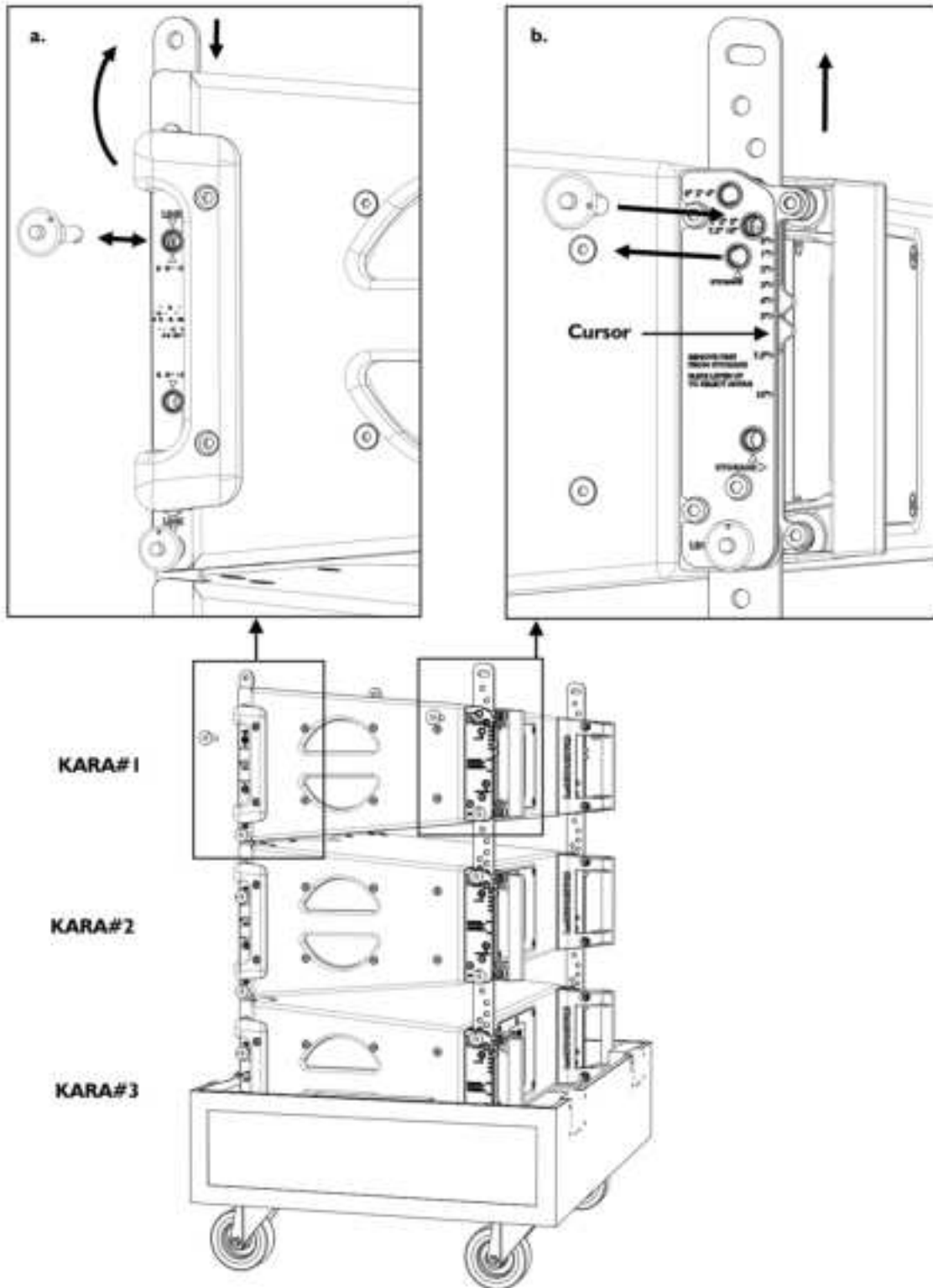

7. Attach the platform to KARA#1 as follows:

- a) Turn the platform feet pointing up and position it above KARA#1 according to the chosen configuration (see [Stacking platform configuration](#) (p.202)).
- b) Lower the platform to slide the four KARA-MINIBU slits along the KARA#1 arms.

i If KARA-ANGARMEX are attached to the KARA-MINIBU, the rear slits are located on both KARA-ANGARMEX.

- a) Secure the front link points together by inserting both R-BLP into the KARA-MINIBU. Depending on the configuration, secure the rear link points together by inserting both R-BLP into the KARA-MINIBU or both TBLP into both KARA-ANGARMEX.

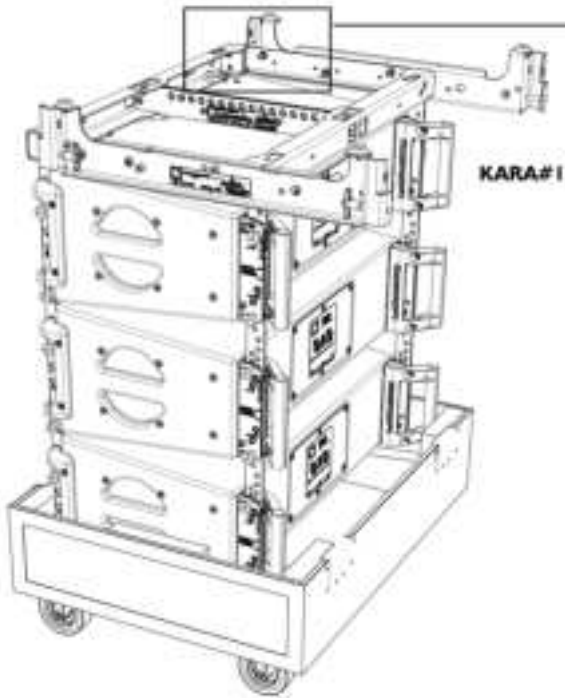

Rear extension configuration without KARA-ANGARMEX

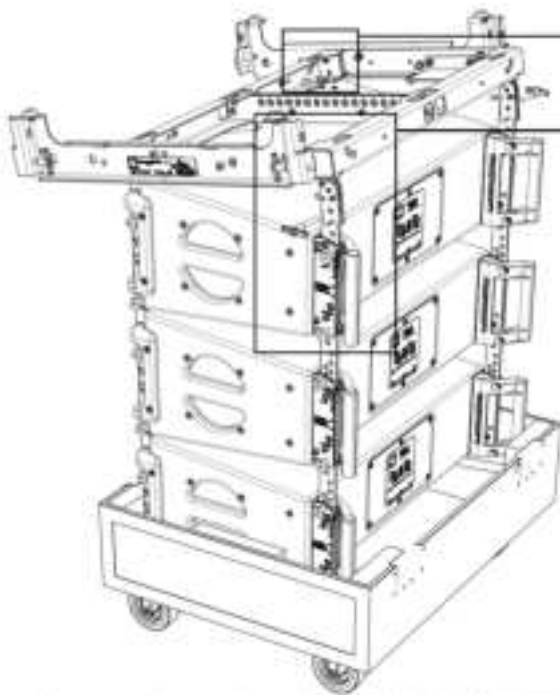
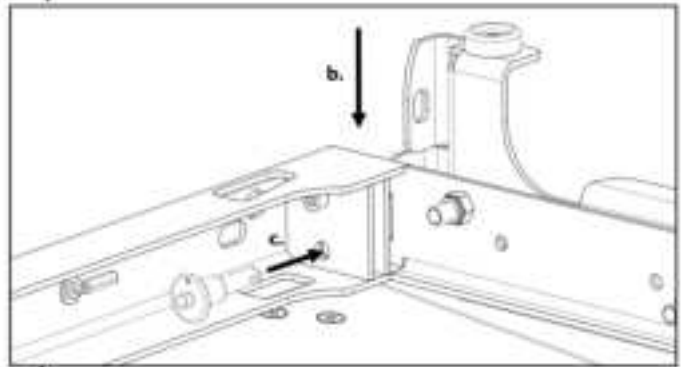

Front extension configuration with KARA-ANGARMEX

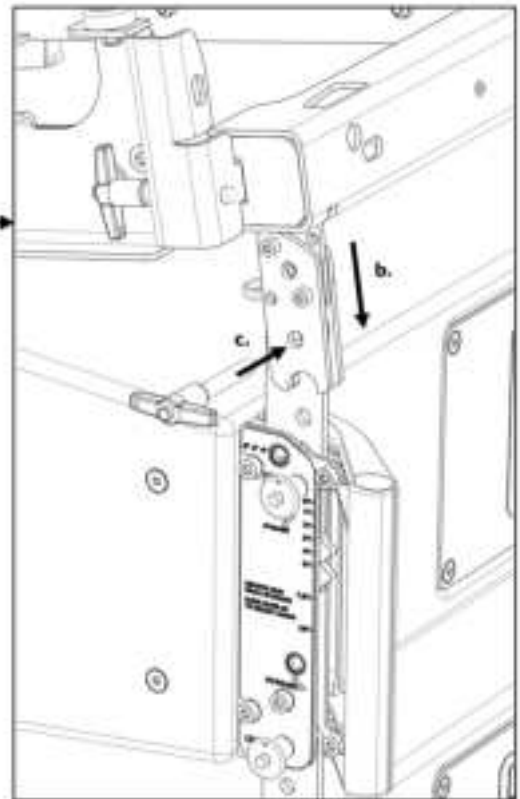

- 8.** Remove the four KARA#1 bottom R-BLP from their **link** holes and re-insert them into their **storage** holes.

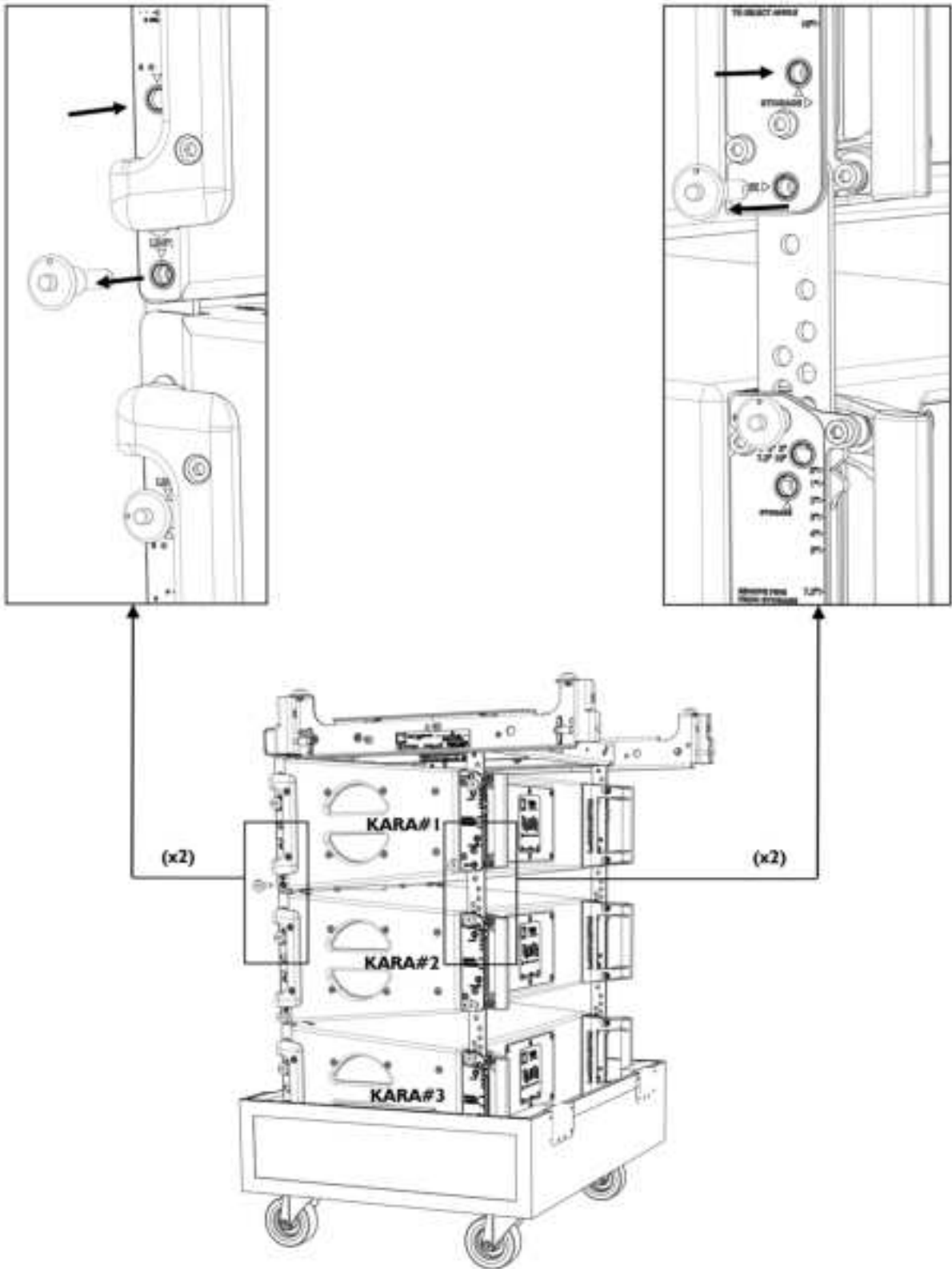

- 9.** Hold the KARA#1/platform assembly, turn it feet downwards and front face towards audience, and put it on the ground.
- 10.** Open the four KARA#2 arms by applying step 6 (p.111).
- 11.** Remove the four KARA#2 bottom R-BLP from their **link** holes and re-insert them into their **storage** holes (see step 8 (p.114)).

12. Attach KARA#2 to KARA#1 as follows:

- a) Turn KARA#2 arms pointing down and front face towards the audience.
- b) Align the four arms with the KARA#1 link points.
- c) Secure the link points together by removing the four KARA#1 top R-BLP from their **storage** holes and reinserting them into their **link** holes.

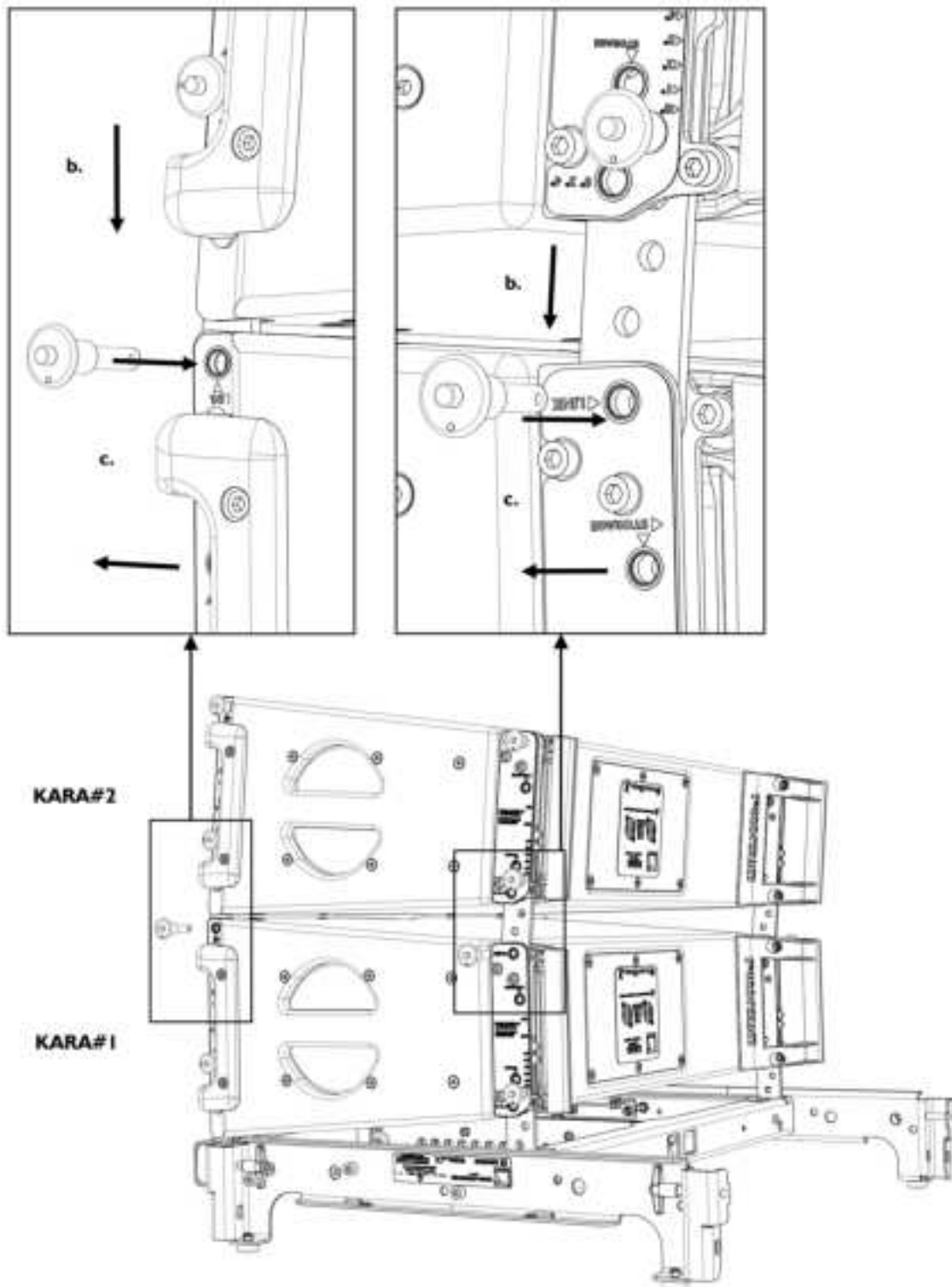

13. Attach KARA#3 to KARA#2 by applying steps 10 (p.114) to 12.

- 14.** Using another full Kara II flight-case, repeat steps 10 (p.114) to 12 until all Kara II enclosures composing the array are assembled.

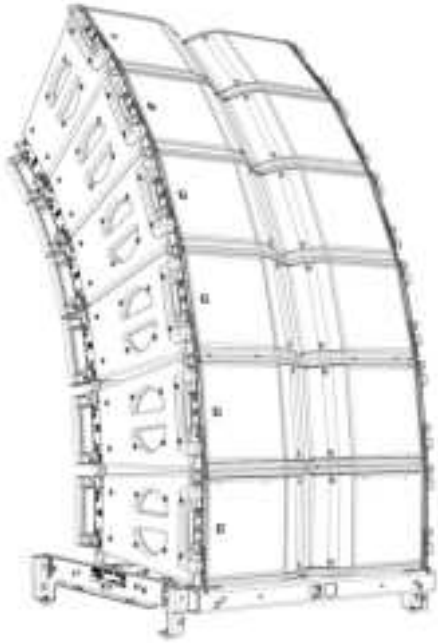

Rear extension configuration

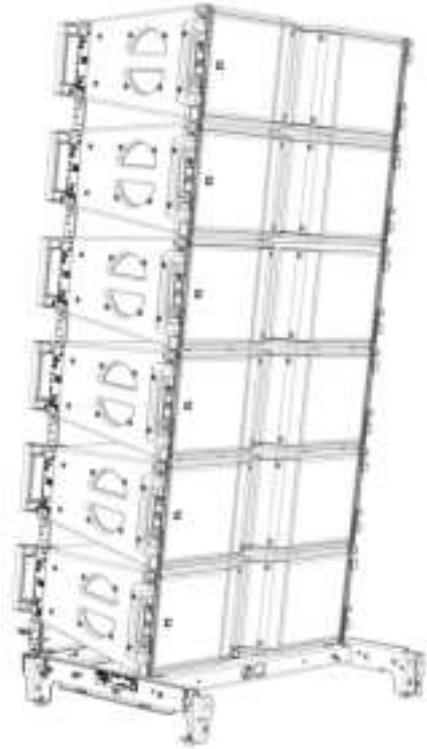

Front extension configuration

- 15.** Secure the array to a fixed point by using a ratchet strap or any other equivalent material (not included).

Array removal

About this task

- ⚠ All along the procedure:
Strictly follow the sequence of the successive steps.
Systematically verify that each BLP is fully inserted.
- ⚠ For clarity purposes the loudspeaker cable removal procedure will not be described.
The loudspeaker cables will not be represented on the figures.

Procedure

1. Detach the ratchet strap or other equivalent material from the stacked array.
2. Bring an empty Kara II flight-case to the rigging location and remove the lid.
3. Remove the top Kara II (KARA#3 for example) from the Kara II below (KARA#2 for example) by removing the four KARA#2 top R-BLP from their **link** holes and re-inserting them into their **storage** holes.

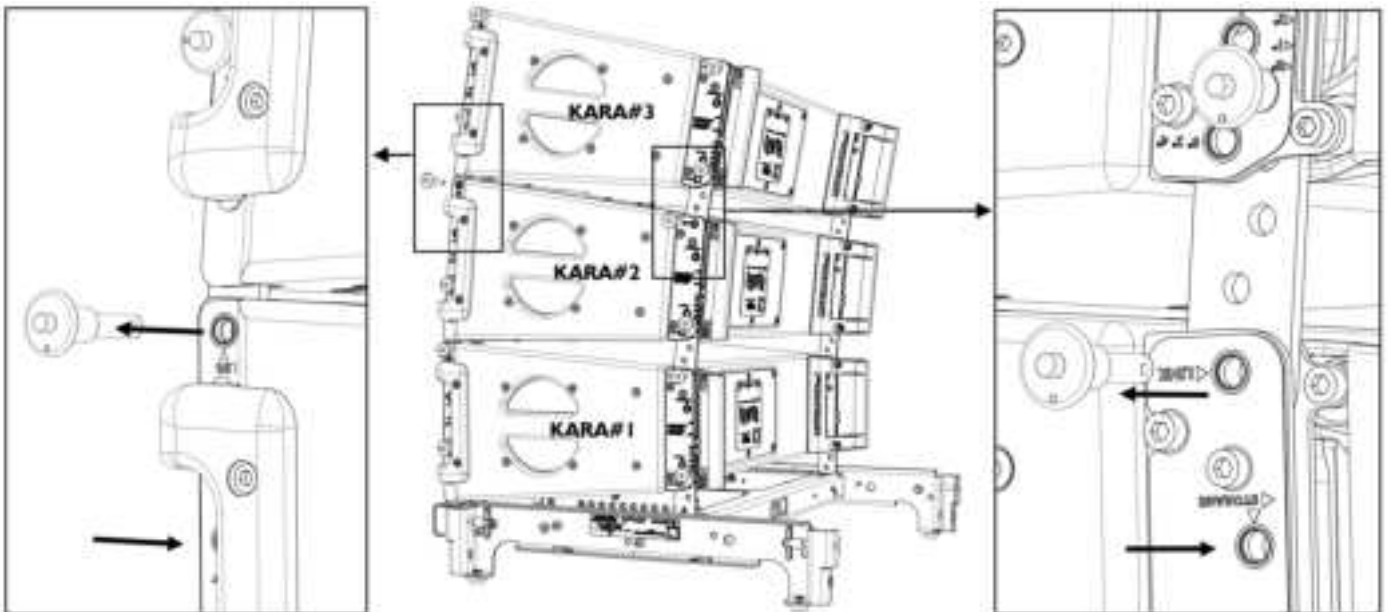

4. Lift up and turn KARA#3 arms pointing up. Put KARA#3 into the flight-case tray.

- ⚠ Pay attention to the tray position: both wedges must slope upwards from front to rear (refer to [Flight-case](#) (p.30)).

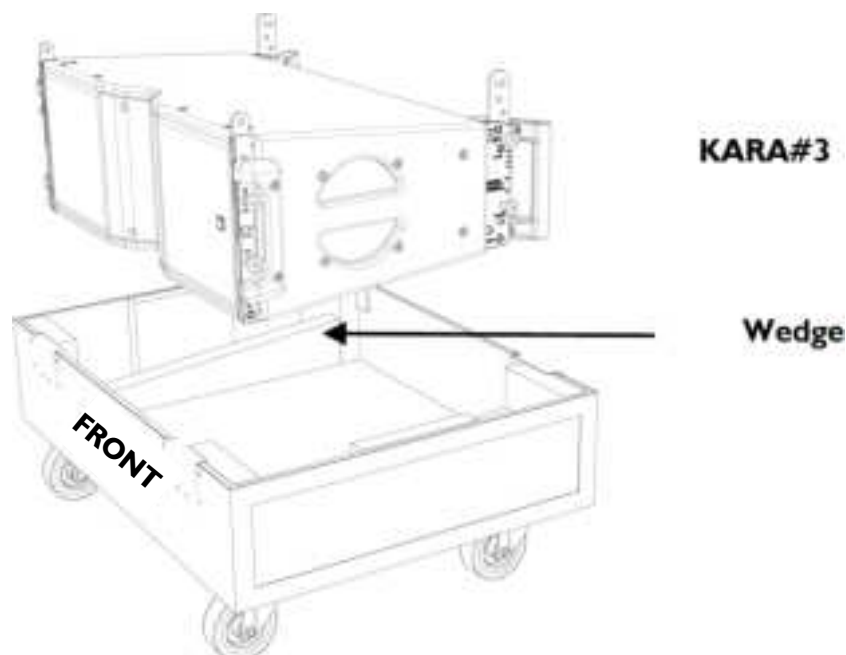

5. Set angle 0° on KARA#3 as follows (repeat on both sides of the enclosure):

- a) Remove the rear top R-BLP from its angle hole.
- b) Slide the angle arm so as to align the cursor with angle label 0°.
- c) Lock the arm in place by re-inserting the R-BLP into angle hole 0°/2°/4°.

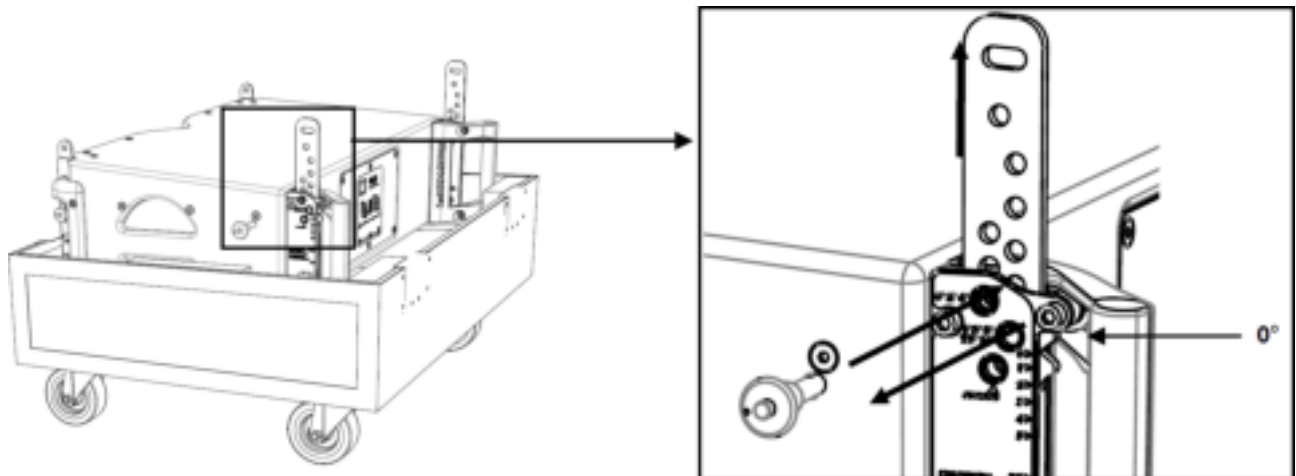

6. Remove KARA#2 from KARA#1 by applying step 3 (p.117).

7. Attach KARA#2 to KARA#3 as follows:

- a) Lift up and turn KARA#2 arms pointing up.
- b) Align the front and rear link points between KARA#2 and KARA#3.
- c) Secure the link points together by removing the four KARA#2 bottom R-BLP from their **storage** holes and reinserting them into their **link** holes.

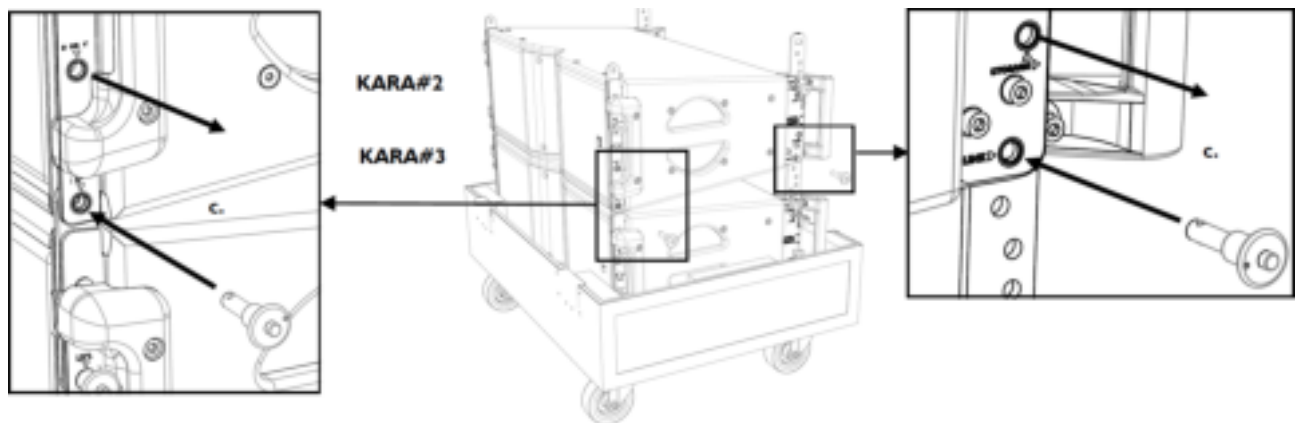

8. Set angles 0° on KARA#2 by applying step 5 (p.118).

9. If the last Kara II to be placed in the flight-case is not attached to the KARA-MINIBU (KARA#4), apply steps 3 (p.117), 7 (p.118), 11 (p.120), and 12 (p.120) for KARA#4 and then apply the procedure a new time from step 2 (p.117) for array KARA#1-3.

If the last Kara II to be placed in the flight-case is attached to the KARA-MINIBU (KARA#1), attach the KARA#1/platform assembly to KARA#2 by applying step 7 (p.118).

10. Remove the platform from KARA#1 as follows:

- a) Remove both KARA-MINIBU front R-BLP.
- b) If KARA-ANGARMEX are attached to the platform, remove both T-BLP from them. Otherwise, remove both KARA-MINIBU rear R-BLP.
- c) Remove the platform from KARA#1.
- d) If KARA-ANGARMEX are attached to the platform, remove them by removing both KARA-MINIBU rear R-BLP.
- e) Re-insert the four R-BLP into the KARA-MINIBU holes.

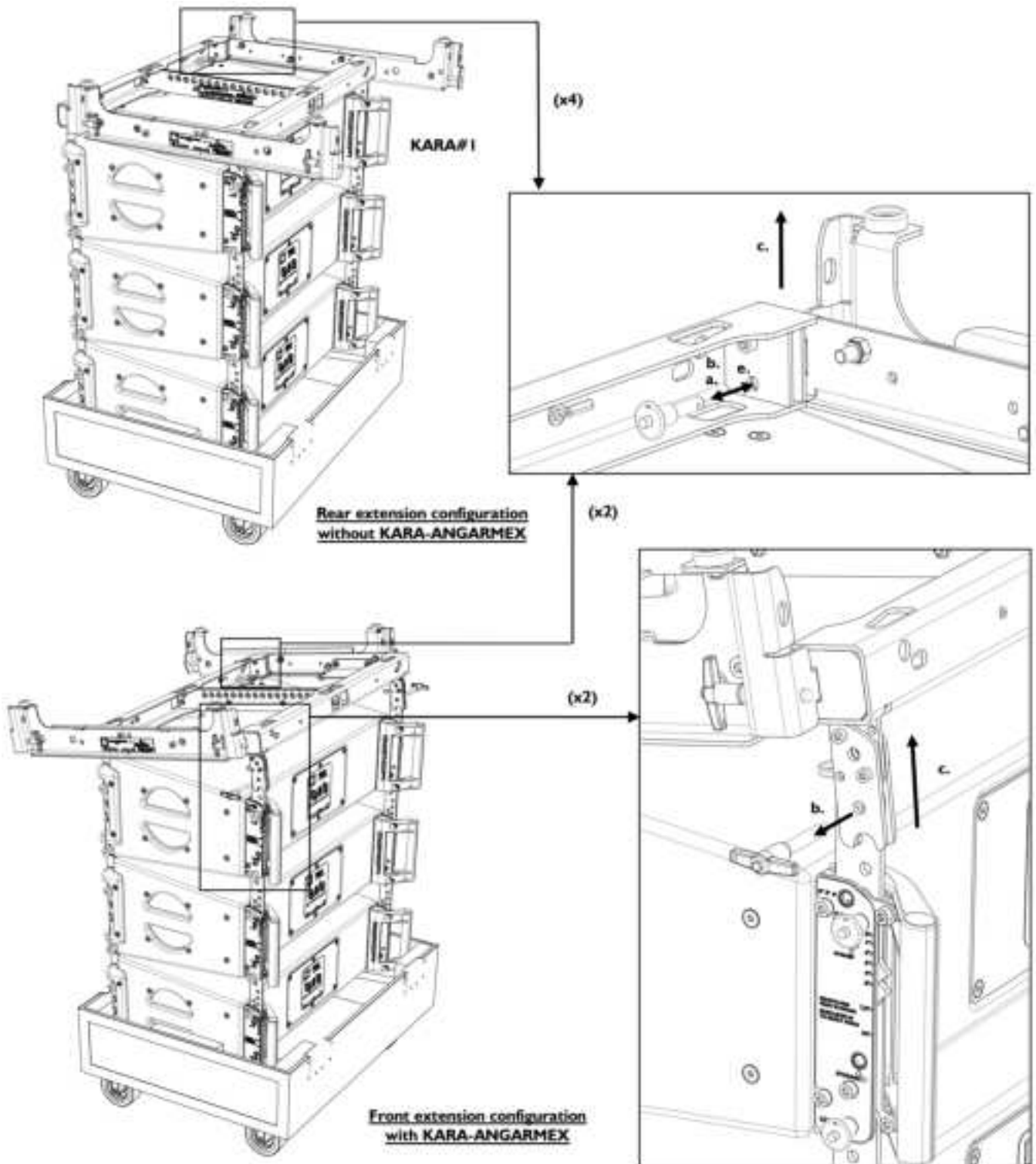

11. Close the four KARA#1 arms as follows (repeat on both sides of the enclosure):

- a) Remove the front top R-BLP from its **link** hole, slide the front arm up, rotate it down, and lock it in place by re-inserting the R-BLP into its **storage** hole.

i The front top **storage** and **link** holes are the same.

- b) Remove the rear top R-BLP from its angle hole, slide the angle arm so as to align the cursor with the storage label, and lock it in place by re-inserting the R-BLP into its **storage** hole.

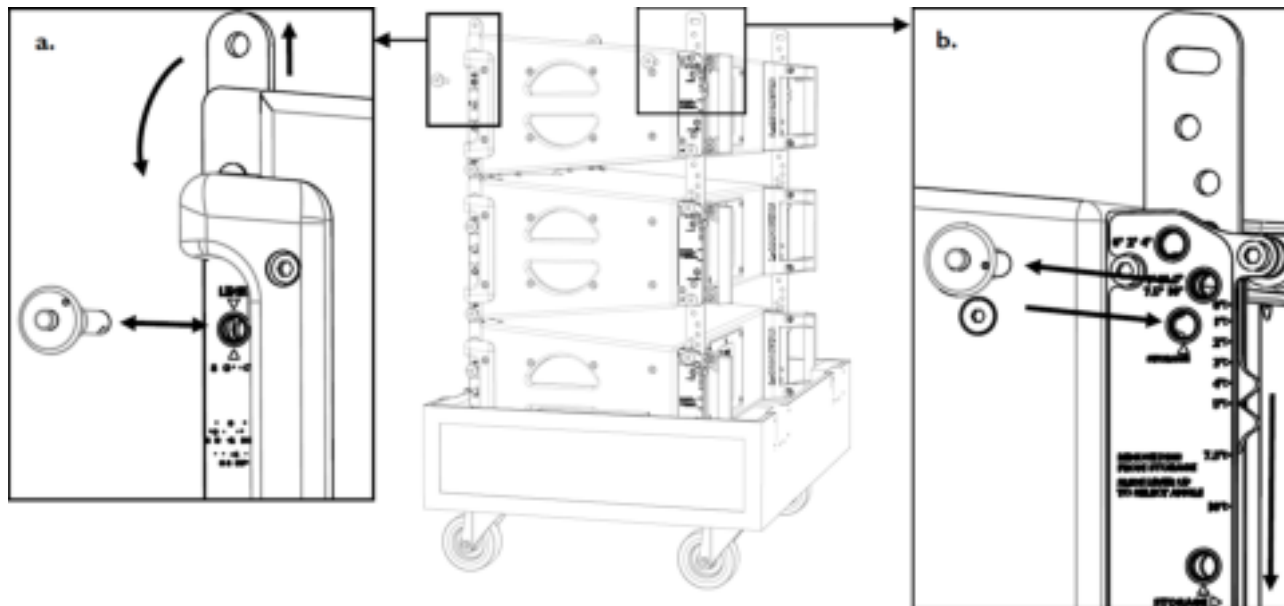

12. Attach the lid to the flight-case.

Stacking an SB18/Kara II mixed array or an SB18 standalone array

Using M-BUMP

Modeling and safety

An SB18/Kara II mixed array or an SB18 standalone array can be stacked directly on the ground (ground stacked array) or onto an M-BUMP/M-BAR/M-JACK platform (platform stacked array). The figure below shows a mixed array of each type and gives the associated conditions of use.

Ground stacked array

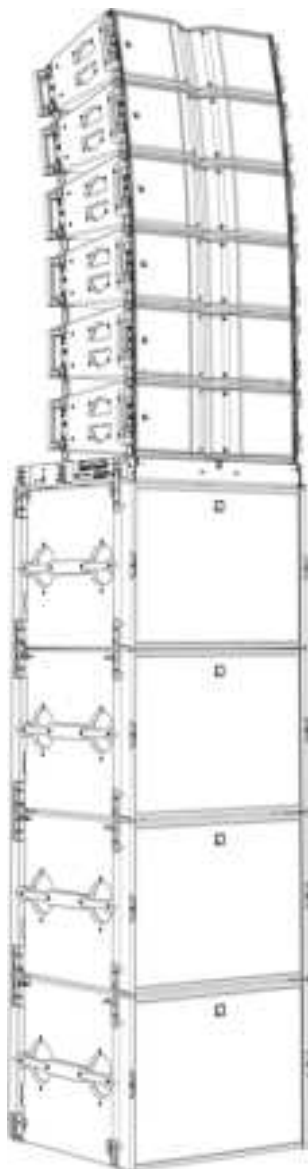

Platform stacked array



- To be stacked on a perfectly horizontal and regular surface ONLY
- Provides tilt adjustments in case of slope surface
- Increases Kara II array site angle range

Ground stacked arrays

! A ground stacked array requires to be installed on a perfectly horizontal and regular surface. A maximum of 4 SB18 can be ground-stacked (refer to [Mechanical safety](#) (p.31)). Refer to the Soundvision model to assess the mechanical safety of a ground-stacked SB18/Kara II mixed array.

SB18/Kara II mixed array mounting procedure: Put the bottom SB18 on the ground (front grill logo upside) and apply the [Array mounting](#) (p.123) procedure WITHOUT using the M-BUMP/M-BAR/M-JACK platform.

SB18 standalone array mounting procedure: Put a first SB18 on the ground with feet (and front grill logo) downside. Put a second SB18 onto the first one and link both enclosures by applying step [4.c](#) (p.75). Repeat the procedure until all SB18 composing the array are rigged. While installing follow the step [8](#) (p.77) indication.

Platform stacked arrays

Any SB18/Kara II platform stacked array must be modeled before installation so as to ensure acoustical and mechanical conformity. This can be done using L-Acoustics [Soundvision Software](#) which will assist the user to:

- Determine the number of required Kara II enclosures.
- Calculate the inter-enclosure angles.

 A maximum of 4 SB18 can be platform-stacked. Refer to the Soundvision model to assess the mechanical safety of a platform-stacked SB18/Kara II mixed array.



The platform must be installed in rear extension configuration if a Kara II array is intended to be rigged with a positive site angle (refer to [Stacking platform configuration](#) (p.200)).

The platform must be installed in front extension configuration if a Kara II array is intended to be rigged with a negative site angle (refer to [Stacking platform configuration](#) (p.200)) and a straight shape (all inter-enclosure angles are close to 0°).

The Kara II, SB18, and M-BUMP fully integrated rigging systems allow assembling the array with no need for any external accessory. The following first procedure describes how to mount a vertical SB18/Kara II or SB18 platform stacked array. The second procedure describes how to disassemble the array.

Array mounting

About this task

-  All along the procedure:
 - Strictly follow the sequence of the successive steps.
 - Systematically verify that each BLP is fully inserted.
 - Systematically verify that each bolt is fully screwed in and secured with pin.
-  For clarity purposes the loudspeaker cabling procedure will not be described.
The loudspeaker cables will not be represented on the figures.

Procedure

1. Place an M-BUMP at the rigging location. Turn it so that the text of the identification plate is upside down and the laser slits are directed towards the audience.

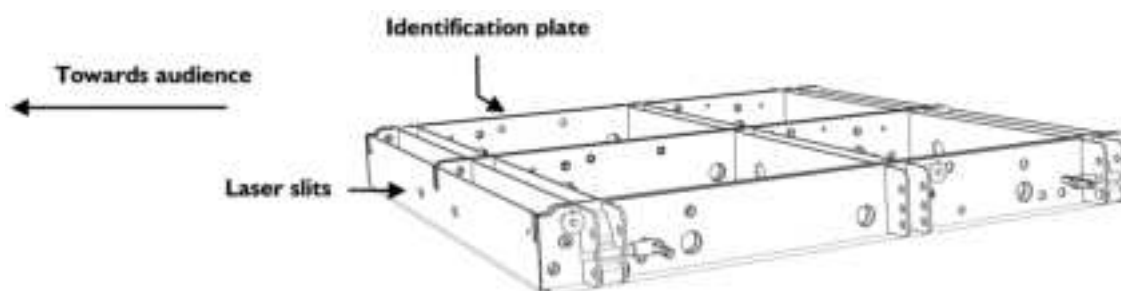

2. Mount two M-BAR/M-JACK assemblies as follows (repeat for each M-BAR):
 - a) Remove the axis and safety pin from M-JACK.

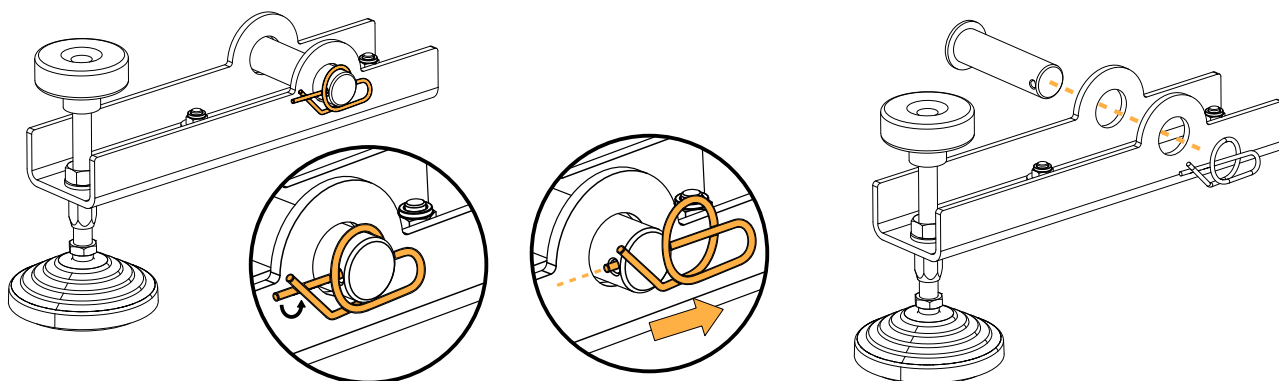

- b) Place an M-JACK under one end of an M-BAR and align the M-JACK hole with the second M-BAR hole.

- c) Secure M-JACK to M-BAR with the axis and safety pin.

Lock the safety pin.

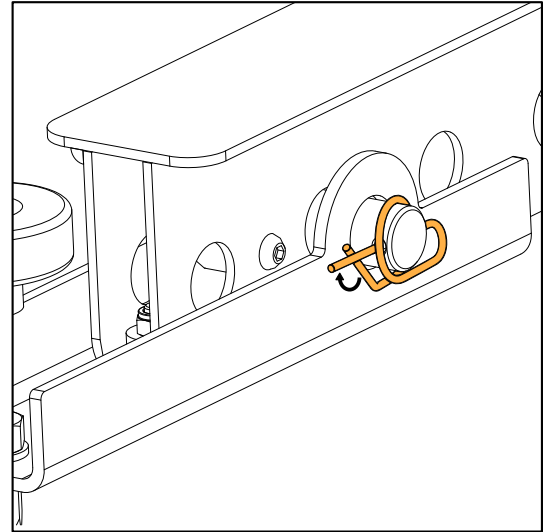
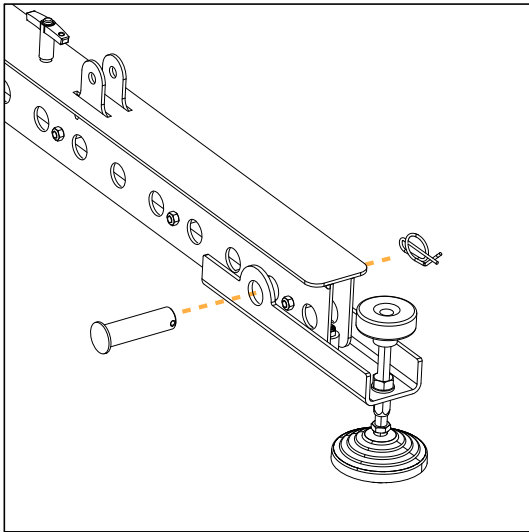

- d) Repeat the procedure to attach a second M-JACK to the other end of the M-BAR.

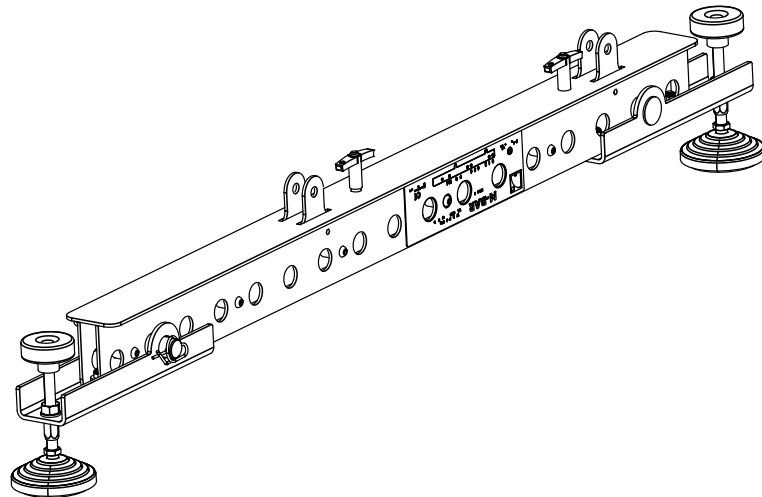

3. According to the chosen configuration (see [Stacking platform configuration](#) (p.200)), mount the stacking platform as follows (repeat for each M-BAR):

- Remove both T-BLP from an M-BAR.
- Lift up one side of the M-BUMP, place the M-BAR beneath it with M-JACK on the ground, and lower the M-BUMP so as to insert both M-BAR studs into the M-BUMP slits.
- Secure by inserting both preceding T-BLP.

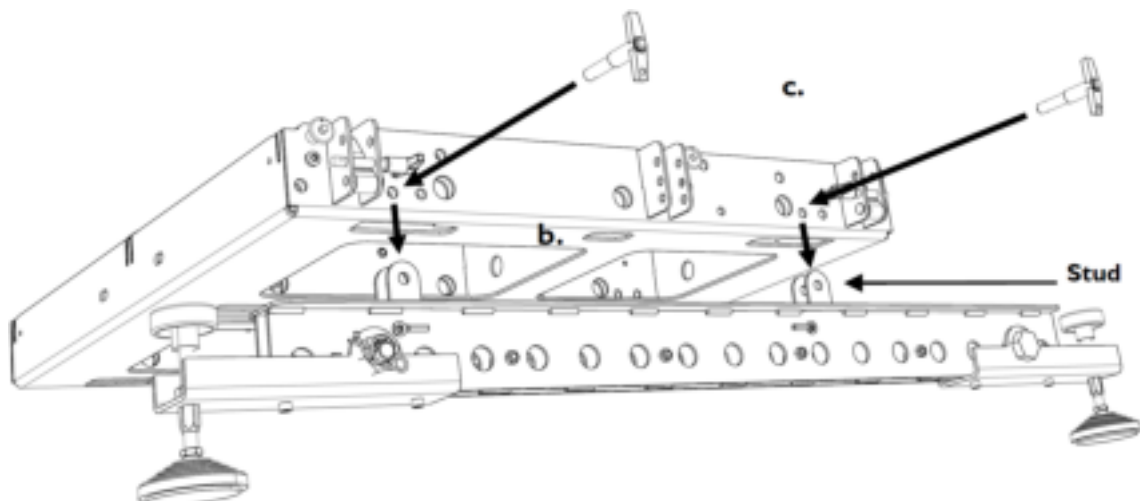

4. Adjust the stacking platform in horizontal position by setting the heights of the 4 M-JACK as follows:
- Unscrew the locking nut on each M-JACK (16 mm hex key).
 - Place an inclinometer device onto the platform in the direction parallel to the M-BAR and rotate the 4 M-JACK knobs to adjust the platform in the horizontal position.

i The inclinometer can be mounted to the integrated laser plate (see [Installing an inclinometer](#) (p.192)).

i In case of high resistance the user can also screw the base nut (14 mm hex key) in place of a knob.

- Put an inclinometer device in the direction perpendicular to the M-BAR and verify that the platform is also horizontal in this direction.

i The handheld inclinometer included in the **TECH TOOLCASE** can be used in this step.

- Lock each M-JACK height by firmly screwing in the locking nut (16 mm hex key).

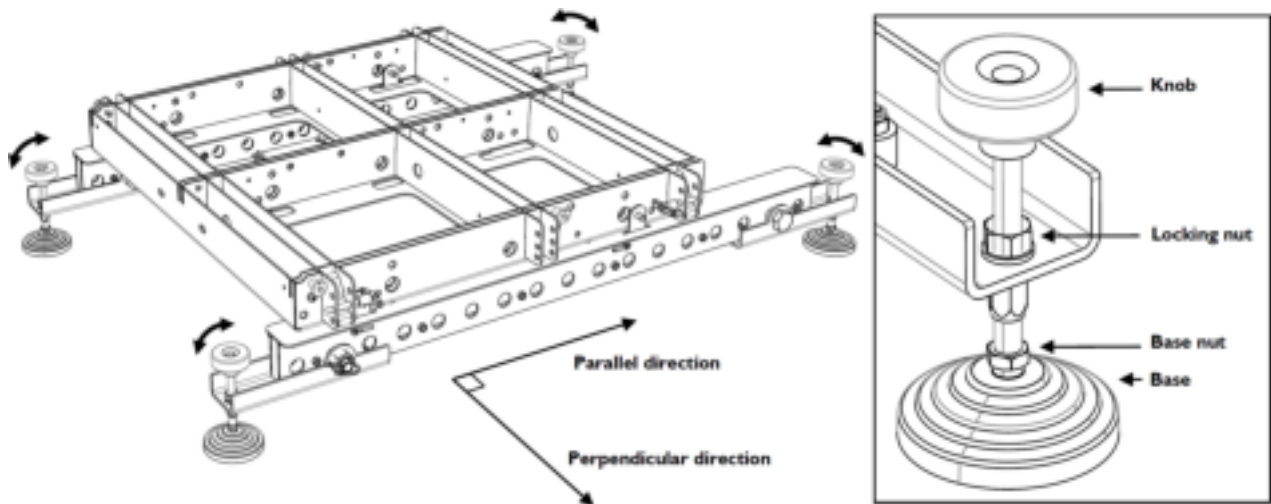

5. Link a first SB18 (hereafter called SB18#1) to the M-BUMP as follows:
- Place SB18#1 at the rigging location and remove the dolly board.
 - Turn the SB18#1 logo upwards. Orient the front grill towards the audience or backwards.
- i** Orient all SB18 composing the array towards the audience to obtain an omnidirectional acoustic pattern or turn one SB18 out of four from front to rear to obtain a cardioid acoustic pattern (refer to the [SB18 user documentation](#)). As an example, the following figures show a cardioid SB18 array.
- Place SB18#1 on the M-BUMP by aligning the four rigging points.
 - Link the four rigging arms of SB18#1 to the M-BUMP as follows: disconnect a T-BLP from SB18#1, rotate the rigging arm down, re-connect the T-BLP to the M-BUMP rigging point and the rigging arm ; repeat this procedure until all 4 arms are secured.

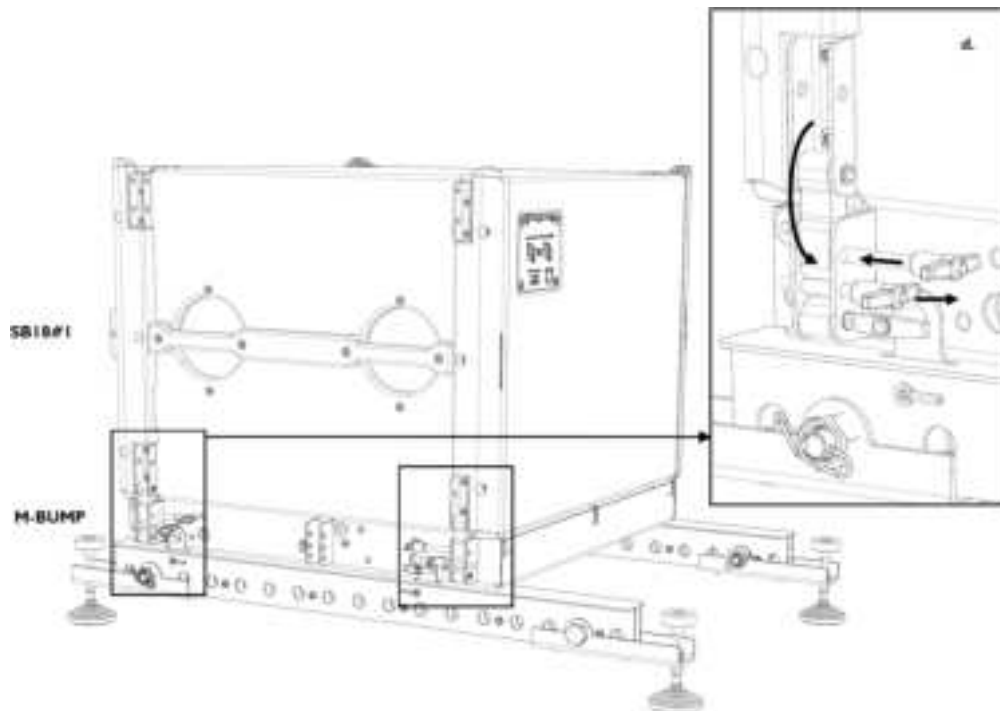

6. Attach a second SB18 (hereafter called SB18#2) to SB18#1 as follows:
 - a) Place SB18#2 at the rigging location and remove the dolly board.
 - b) Turn SB18#2 logo upwards and front face towards the audience.
 - c) Place SB18#2 on SB18#1 by aligning the four rigging points.
 - d) Attach the four rigging arms of SB18#2 to SB18#1 as follows: disconnect a T-BLP from SB18#2, rotate the rigging arm down, re-connect the T-BLP to the SB18#1 rigging point and the rigging arm; repeat this procedure until all 4 arms are secured.

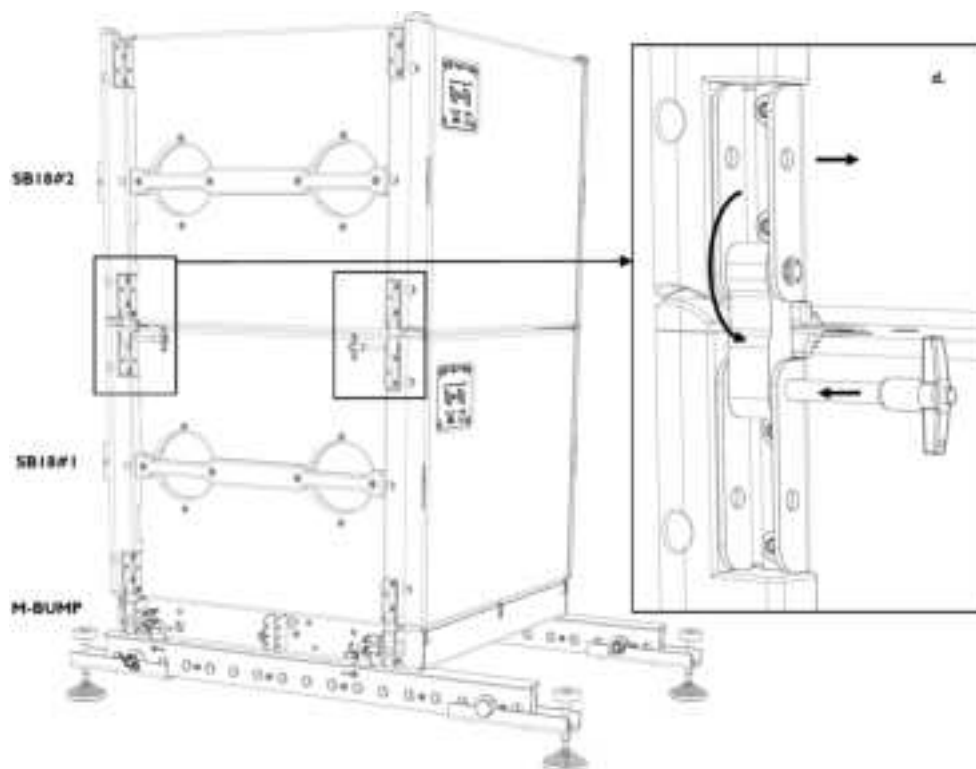

7. Repeat step 6 (p.126) until all SB18 enclosures composing the array are rigged.

i Orient all SB18 composing the array towards the audience to obtain an omnidirectional acoustic pattern or turn one SB18 out of four from front to rear to obtain a cardioid acoustic pattern (refer to the [SB18 user documentation](#)). As an example, the following figures show a cardioid SB18 array.

8. If the array is intended to be an SB18 standalone array, apply the following last procedure:

- Check if the stacking platform is still horizontal. If not, refer to step 4 (p.98) from the **Array mounting** procedure in **Stacking a Kara II standalone array using M-BUMP**.
- Secure the system to a fixed point using a ratchet strap or any other applicable material (not provided).

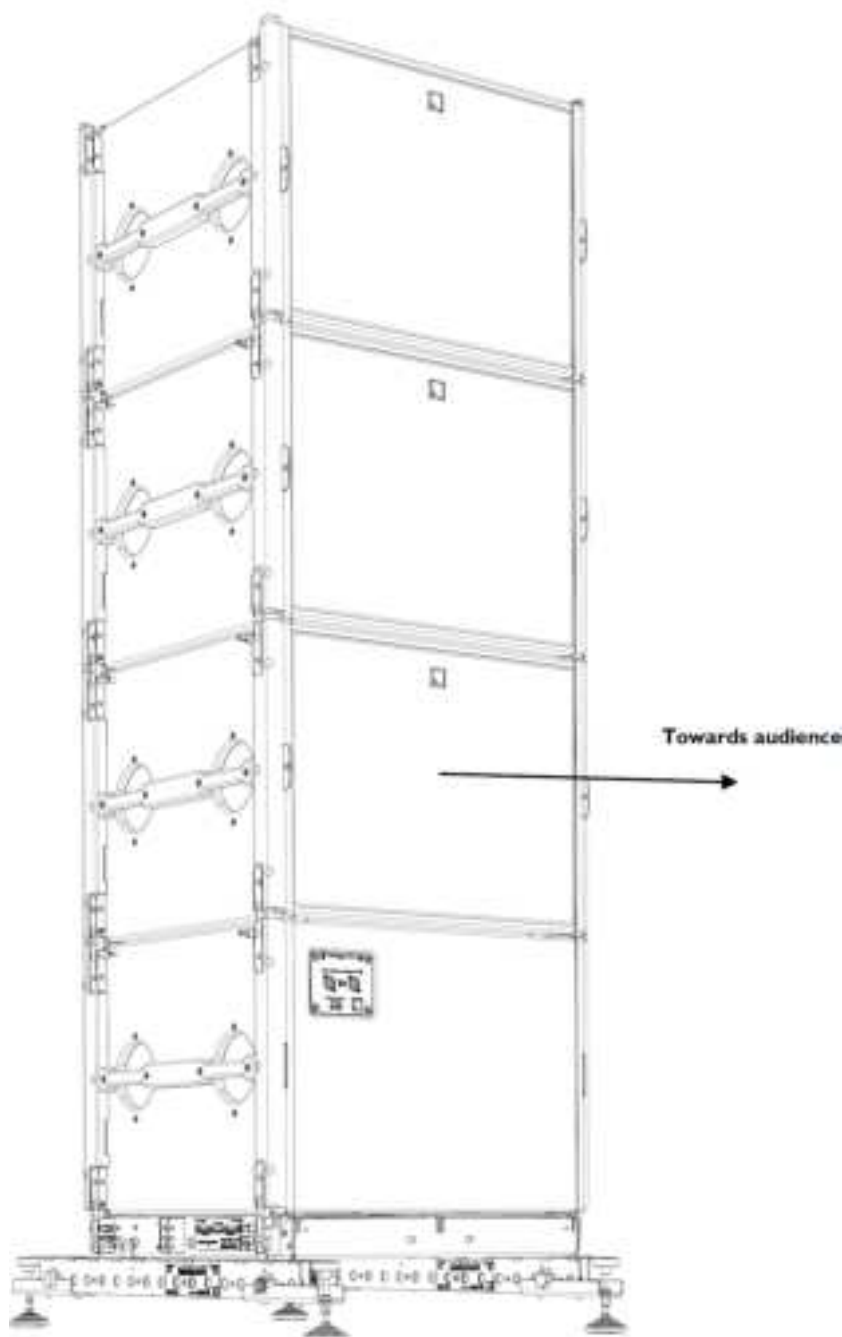

If the array is intended to be an SB18/Kara II mixed array, place a second M-BUMP at the rigging location. Turn it so that the text of the identification plate is upside down and the laser slits are directed towards the audience, and place it on the top SB18.

i For clarity purposes, the procedure is continued with an array composed of one SB18 enclosure.

9. Link the 4 rigging points between the M-BUMP and the top SB18 as follows (repeat for each one): remove the external T-BLP from the M-BUMP, rotate the arm downwards and secure it to the SB18 by re-inserting the T-BLP.

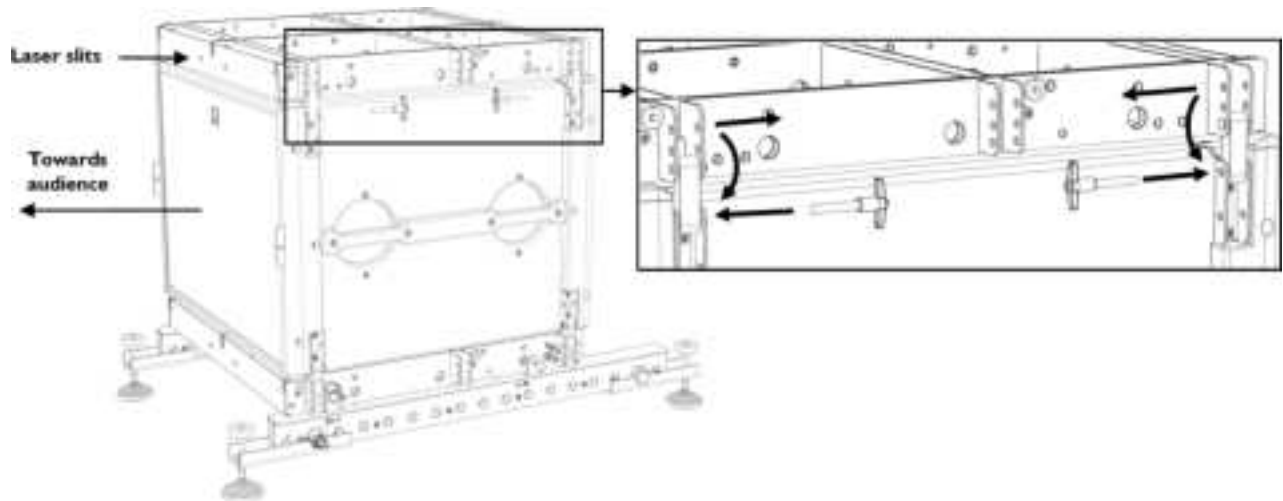

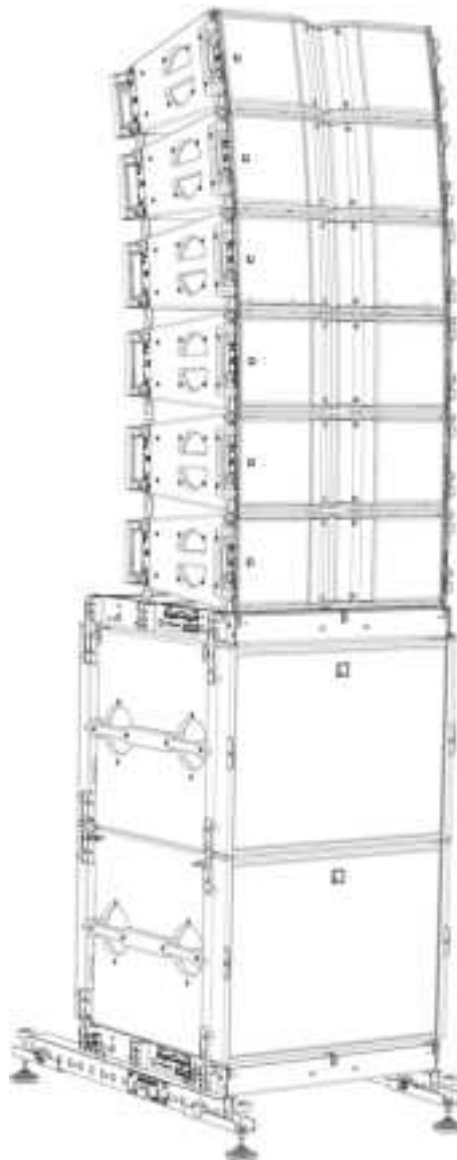

10. Finish the procedure by applying steps 5 (p.98) to 15 from the **Array mounting** procedure in **Stacking a Kara II standalone array using M-BUMP**.



Array removal

About this task

-  All along the procedure:
Strictly follow the sequence of the successive steps.
Systematically verify that each BLP is fully inserted.
-  For clarity purposes the loudspeaker cable removal procedure will not be described.
The loudspeaker cables will not be represented on the figures.

Procedure

1. In case of SB18 standalone array, directly go to step 4 (p.129).
In case of SB18/Kara II mixed array, begin the procedure by applying steps 1 (p.104) to 13 from the **Array removal** procedure in **Stacking a Kara II standalone array using M-BUMP** and then continue to next step.
2. Unlink the 4 rigging points between the M-BUMP and the SB18 as follows (repeat for each one): remove the T-BLP from the SB18, rotate the arm upwards and lock it by re-inserting the T-BLP on the M-BUMP.

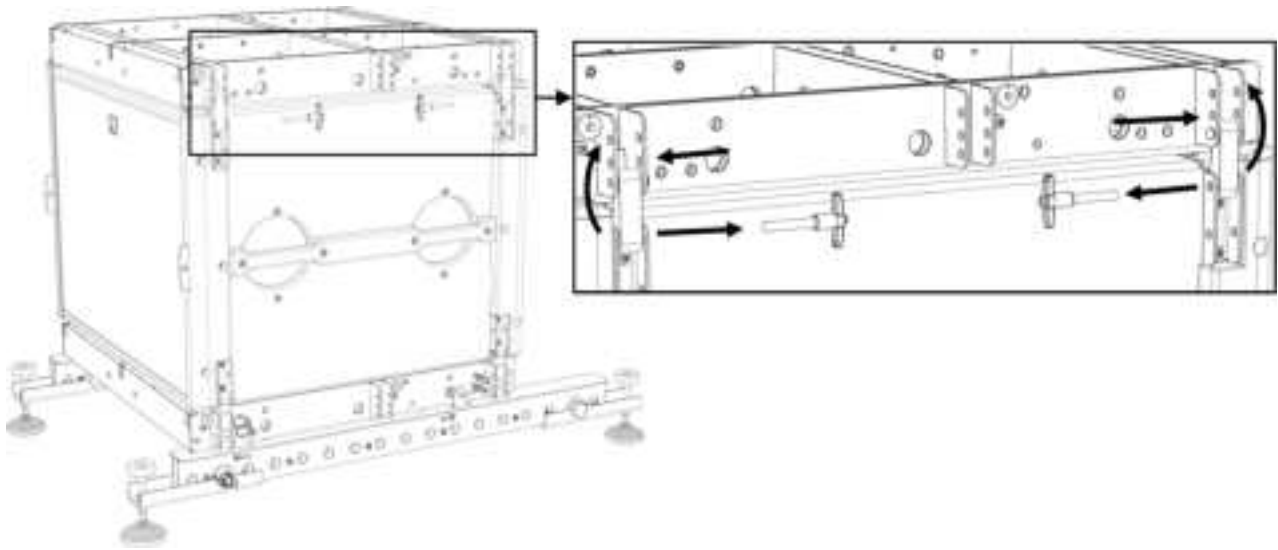

3. Remove the M-BUMP from the SB18.
 -  For clarity purposes, the procedure is continued with an array composed of two SB18 enclosures.
4. If not already done, remove the ratchet strap from the array.
5. Unlink the top SB18 (SB18#2 for example) from the SB18 below (SB18#1 for example) as follows:
 - a) Disconnect a T-BLP from the top part of SB18#1.
 - b) Rotate the rigging arm up.
 - c) Re-connect the T-BLP to SB18#2 so as to lock the rigging arm in closed position.
 - d) Repeat this procedure until all 4 arms are locked in closed position.

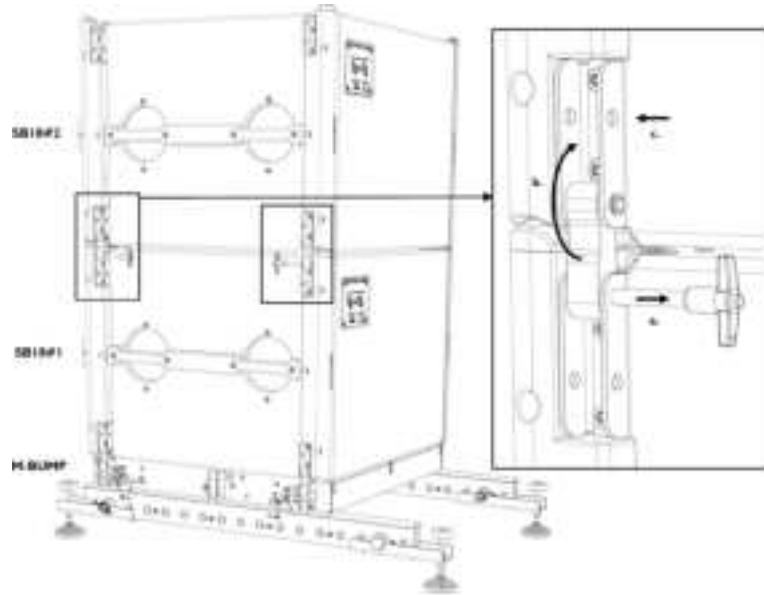

6. Attach a dolly board to SB18#2 and remove SB18#2 from the rigging location.
7. Repeat steps 5 (p.129) and 6 (p.130) until all SB18 are separated from the array.
8. Remove both M-BAR/M-JACK assemblies from the M-BUMP as follows (repeat for each one):
 - a) Remove both T-BLP from the M-BAR studs.
 - b) Lift up the corresponding side of the M-BUMP and remove the M-BAR.
 - c) Re-insert both T-BLP into their storage holes.

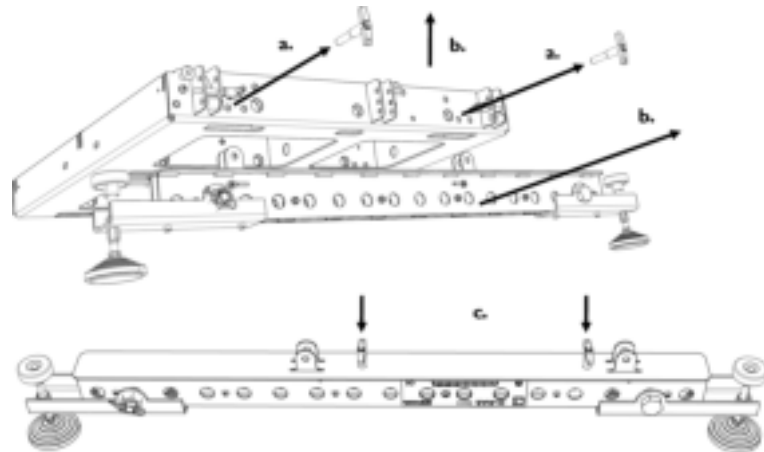

9. Remove both M-JACK from each M-BAR.

On each M-JACK, unlock the safety pin and remove the safety pin and the axis.

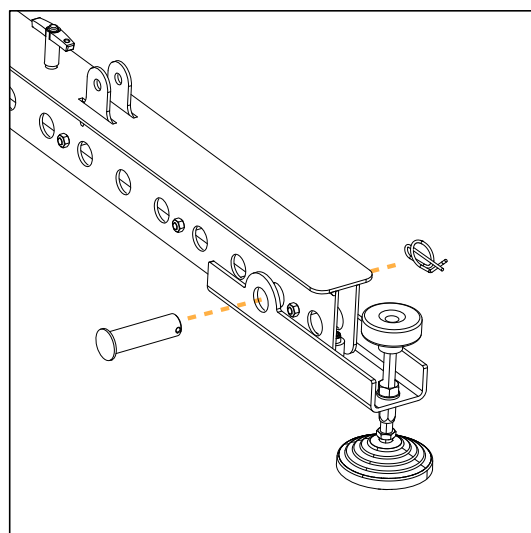
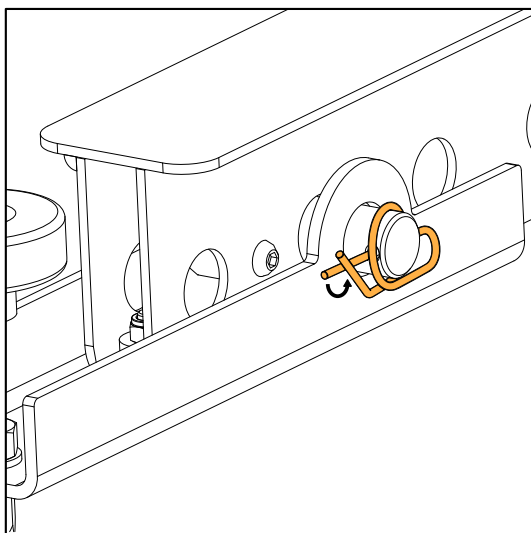

Using KARA-MINIBU

Modeling and safety

An SB18/Kara II mixed array or an SB18 standalone array must be stacked directly on the ground (ground stacked array).

Any SB18/Kara II ground stacked array must be modeled before installation so as to ensure acoustical and mechanical conformity. This can be done using L-Acoustics [Soundvision Software](#) which will assist the user to:

- Determine the number of required Kara II enclosures (acoustic data not available for subwoofers).
- Calculate the inter-enclosure angles.

 A ground stacked array requires to be installed on a perfectly horizontal and regular surface.
A maximum of 4 SB18 can be ground-stacked (refer to [Mechanical safety](#) (p.31)). Refer to the Soundvision model to assess the mechanical safety of a ground-stacked SB18/Kara II mixed array.

SB18/Kara II mixed array assembling procedure: Apply [Array mounting](#) (p.131).

SB18 standalone array assembling procedure: Stack a first SB18 on the ground, front face logo down. Stack a second SB18 onto the first one and attach it by applying step [2.c](#) (p.86). Repeat the procedure until all SB18 composing the array are assembled.

Array mounting

About this task

 All along the procedure:
Strictly follow the sequence of the successive steps.
Systematically verify that each BLP is fully inserted.
Systematically verify that each bolt is fully driven on the KARA-MINIBU EX.

 For clarity purposes the loudspeaker cabling procedure will not be described.
The loudspeaker cables will not be represented on the figures.

Required tools

- electric screwdriver with torque selector
- 6 mm hex bit / 6 mm hex bit
- 13 mm hex key

Procedure

1. Bring a first SB18 (SB18#1) to the rigging location, remove the dolly board, and stack it on the ground logo up.

 Orient all SB18 composing the array towards the audience to obtain an omnidirectional acoustic pattern or turn one SB18 out of four from front to rear to obtain a cardioid acoustic pattern (refer to the [SB18 user documentation](#)). As an example, the following figures show a cardioid SB18 array.

2. In the same way, stack a second SB18 (SB18#2) onto SB18#1.

3. Attach SB18#2 to SB18#1 as follows:

- a) Remove a T-BLP from SB18#2.
- b) Rotate the link arm down.
- c) Secure the link arm to SB18#1 by re-inserting the T-BLP into the SB18#1 top link point.
- d) Repeat this procedure until all four arms are secured to SB18#1.

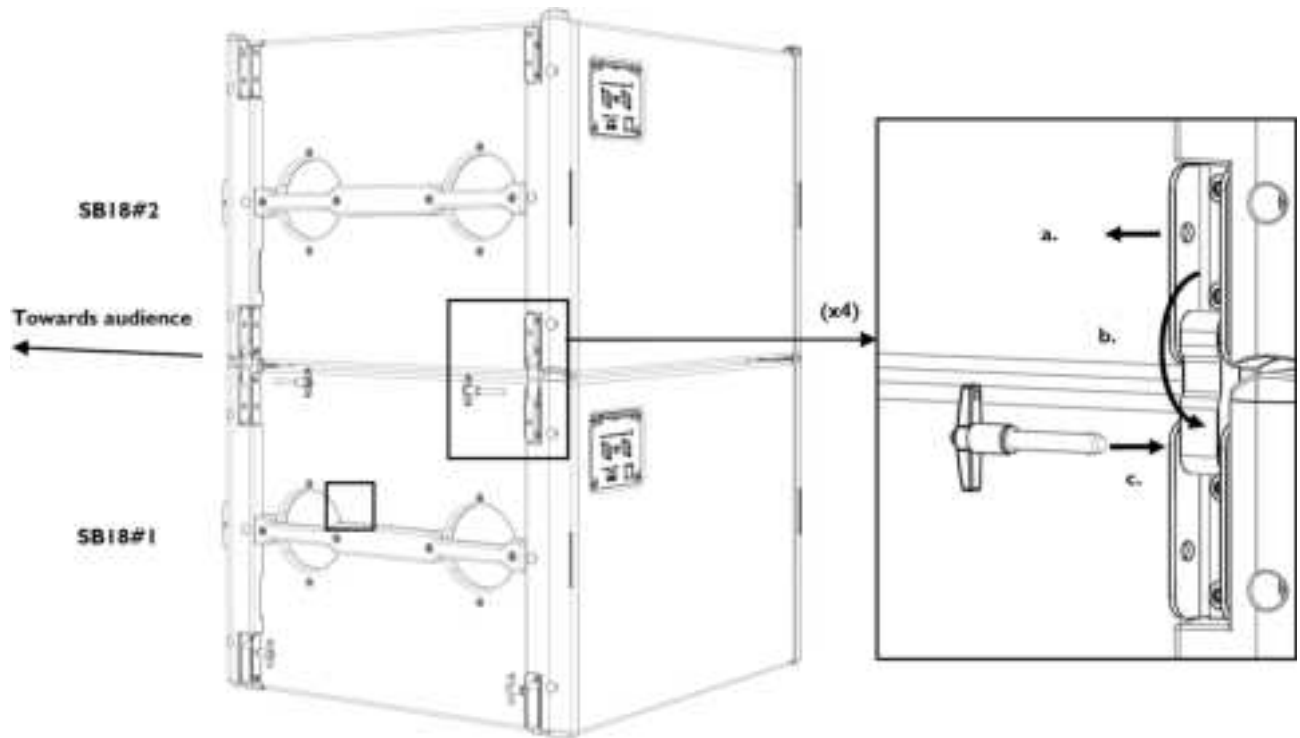

4. Repeat steps 2 (p.131) and 3 (p.131) until all SB18 composing the array are assembled.
5. Assemble a KARA-MINIBU/KARA-MINIBUEX stacking platform as follows:
 - a) Turn the KARA-MINIBU so that the text of the identification plate is upside down.
 - b) Position a first KARA-MINIBUEX on the laser plate side of the KARA-MINIBU by turning it feet pointing down and inserting the stud into the slit of the KARA-MINIBU located near the laser plate.
 - c) Drive 3 bolts to the 3 holes shown in the figure below (6 mm hex bit, 13 mm hex key, 7 N.m/63 in.lb f).
 - d) Repeat the procedure with a second KARA-MINIBUEX on the other side of the KARA-MINIBU.



Put the stacking platform in rear extension configuration only (see [Stacking platform configuration](#) (p.202)).

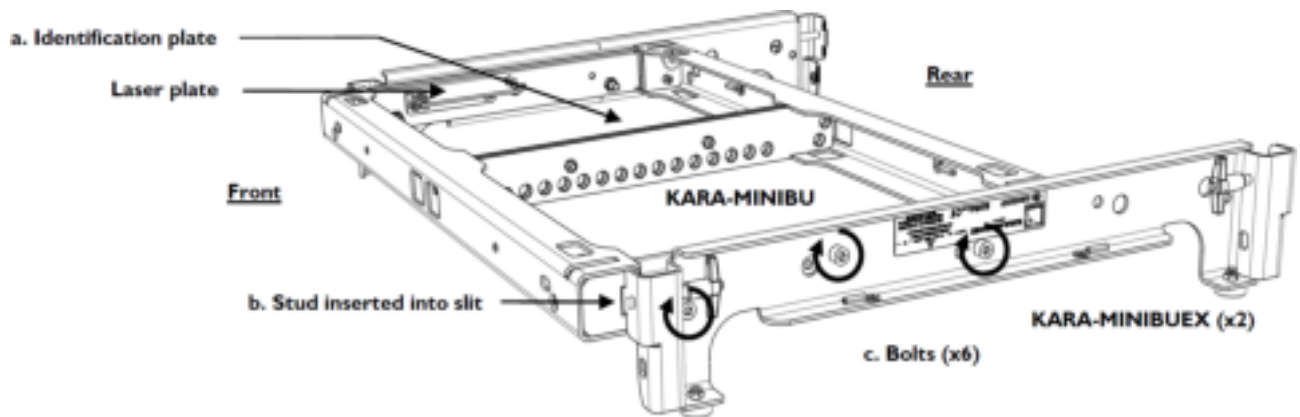

- 6.** If KARA-ANGARMEX are intended to be used (see [Array site angle setting](#) (p.203)), attach two KARA-ANGARMEX to the platform as follows:
- Remove an R-BLP from a rear corner of the KARA-MINIBU.
 - Insert the single part of a first KARA-ANGARMEX into the corner slit: position it vertically with sling ring towards the front and indentation resting on the spacer.
 - Align the KARA-ANGARMEX and KARA-MINIBU holes and secure them together by re-inserting the R-BLP.
 - Repeat the procedure with a second KARA-ANGARMEX on the other rear corner of the KARA-MINIBU.

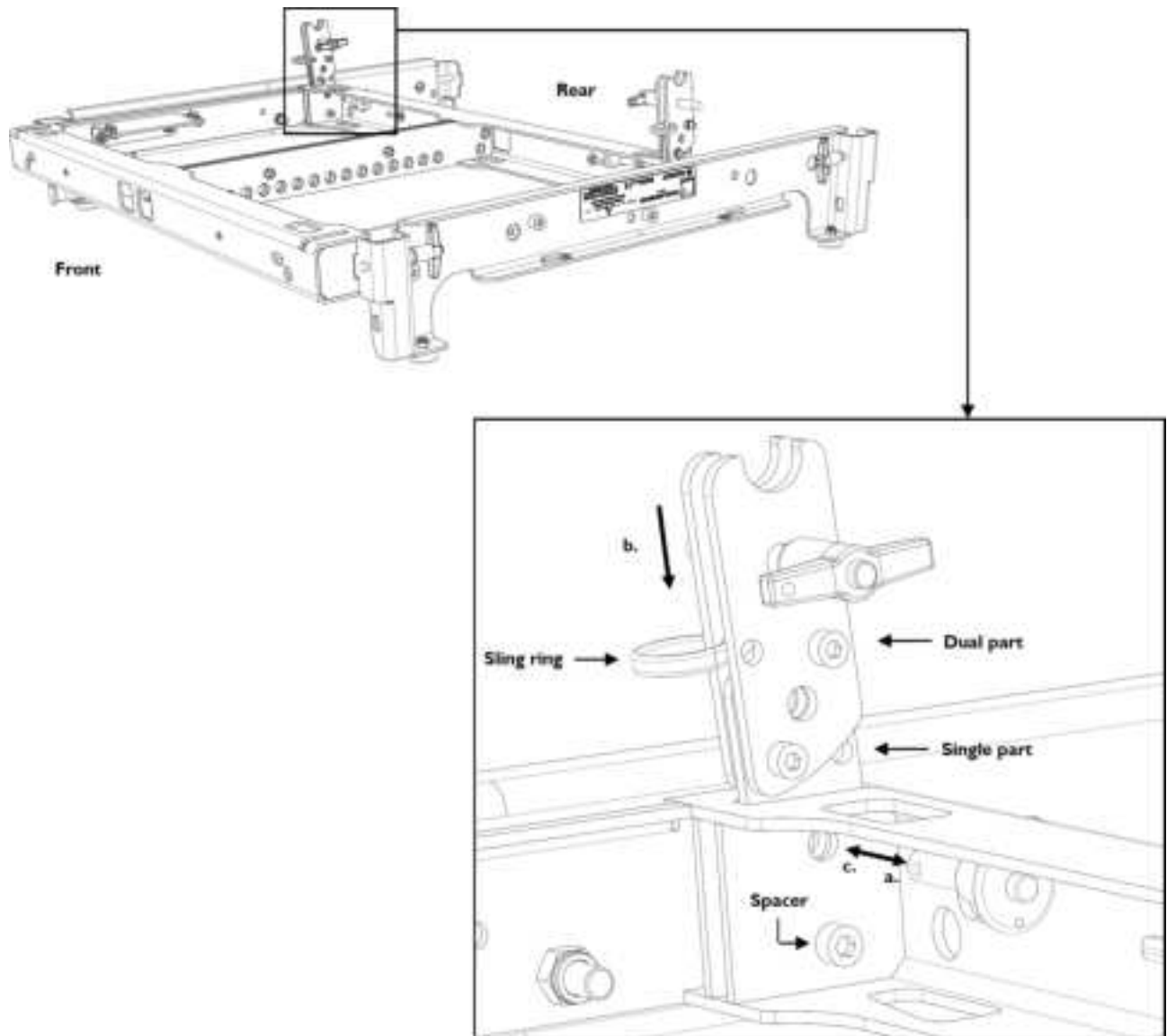

- 7.** Remove both front R-BLP from the KARA-MINIBU.
- 8.** If KARA-ANGARMEX are attached to the KARA-MINIBU, remove both T-BLP from them. Otherwise, remove both rear R-BLP from the KARA-MINIBU.
- 9.** Bring a full Kara II flight-case to the stacking location and remove the lid. In the following, the enclosures will be designated as KARA#1 to KARA#3 from top to bottom.

10. Open the four KARA#1 arms as follows (repeat on both sides of the enclosure):

- a) Remove the front top R-BLP from its **storage** hole, rotate the front arm up, slide it down, and lock it in place by re-inserting the R-BLP into its **link** hole.

i A **link** hole is indicated by a yellow circle.

i The front top **storage** and **link** holes are the same.

- b) Remove the rear top R-BLP from its **storage** hole, slide the angle arm so as to align the cursor with the chosen angle label, and lock it in place by re-inserting the R-BLP into the corresponding angle hole (0°/2°/4° or 1°/3°/5°/7.5°/10°).

i Refer to [Array site angle setting](#) (p.203) to obtain the angle value corresponding to the chosen array site angle.

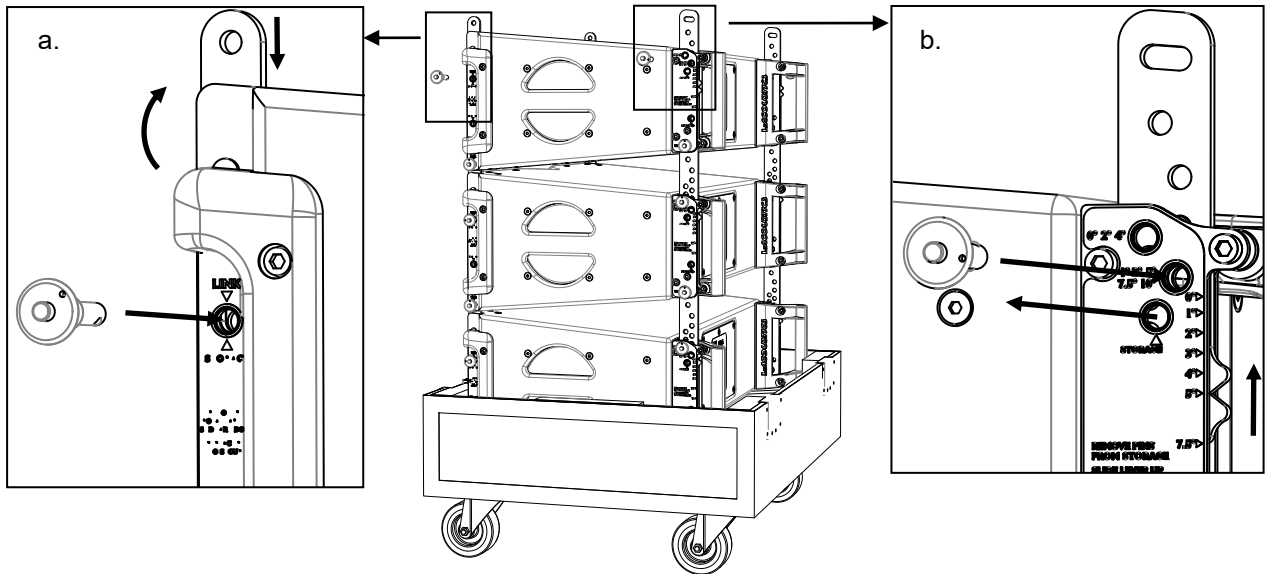

11. Attach the platform to KARA#1 as follows:

- a) Turn the platform feet pointing up and position it above KARA#1 in rear extension configuration (see [Stacking platform configuration](#) (p.202)).
- b) Lower the platform to slide the four KARA-MINIBU slits along the KARA#1 arms.



If KARA-ANGARMEX are attached to the KARA-MINIBU, the rear slits are located on both KARA-ANGARMEX.

- c) Secure the front link points together by inserting both R-BLP into the KARA-MINIBU. Depending on the configuration, secure the rear link points together by inserting both R-BLP into the KARA-MINIBU or both T-BLP into both KARA-ANGARMEX.

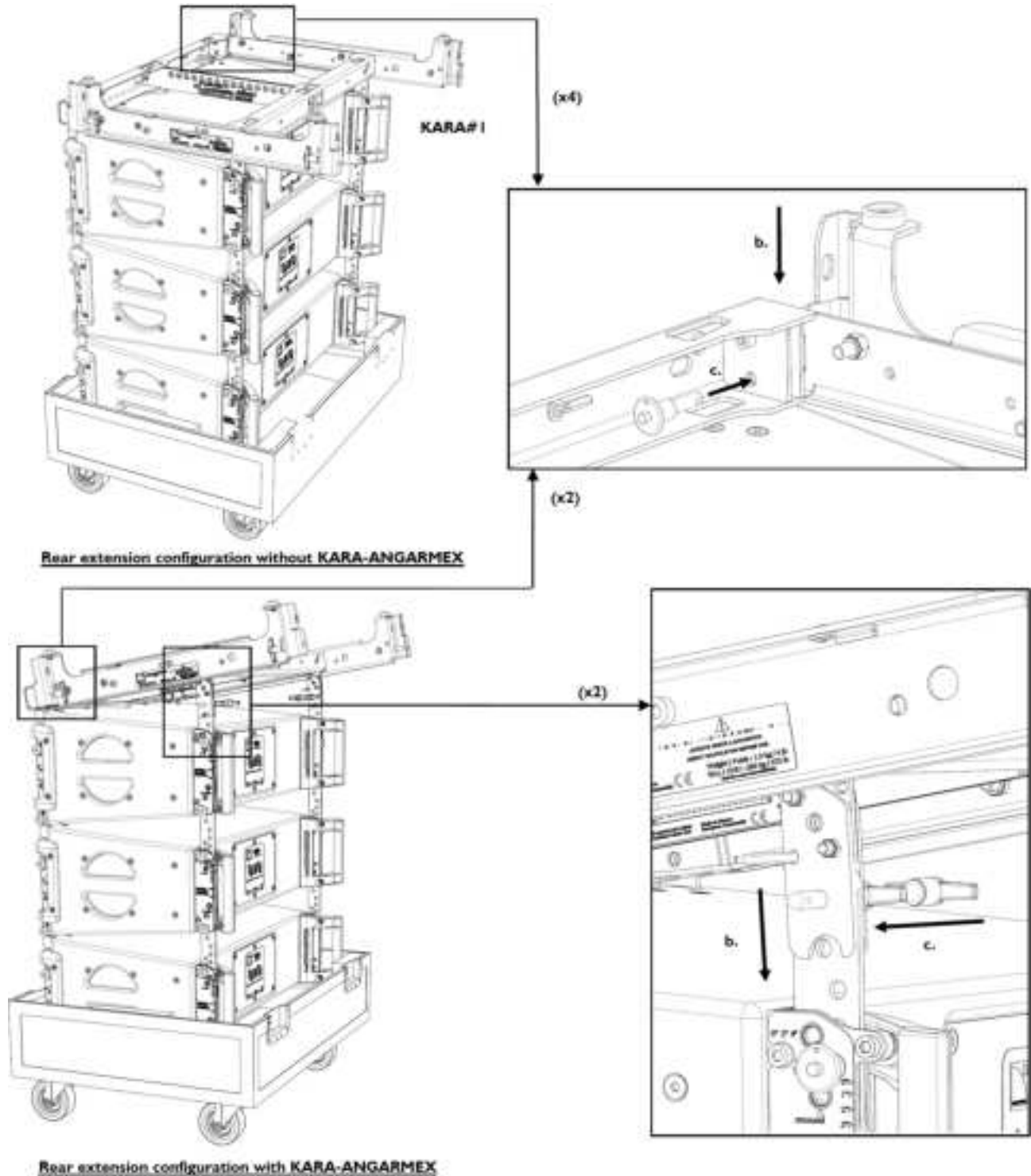

12. Remove the four KARA#1 bottom R-BLP from their **link** holes and re-insert them into their **storage** holes.

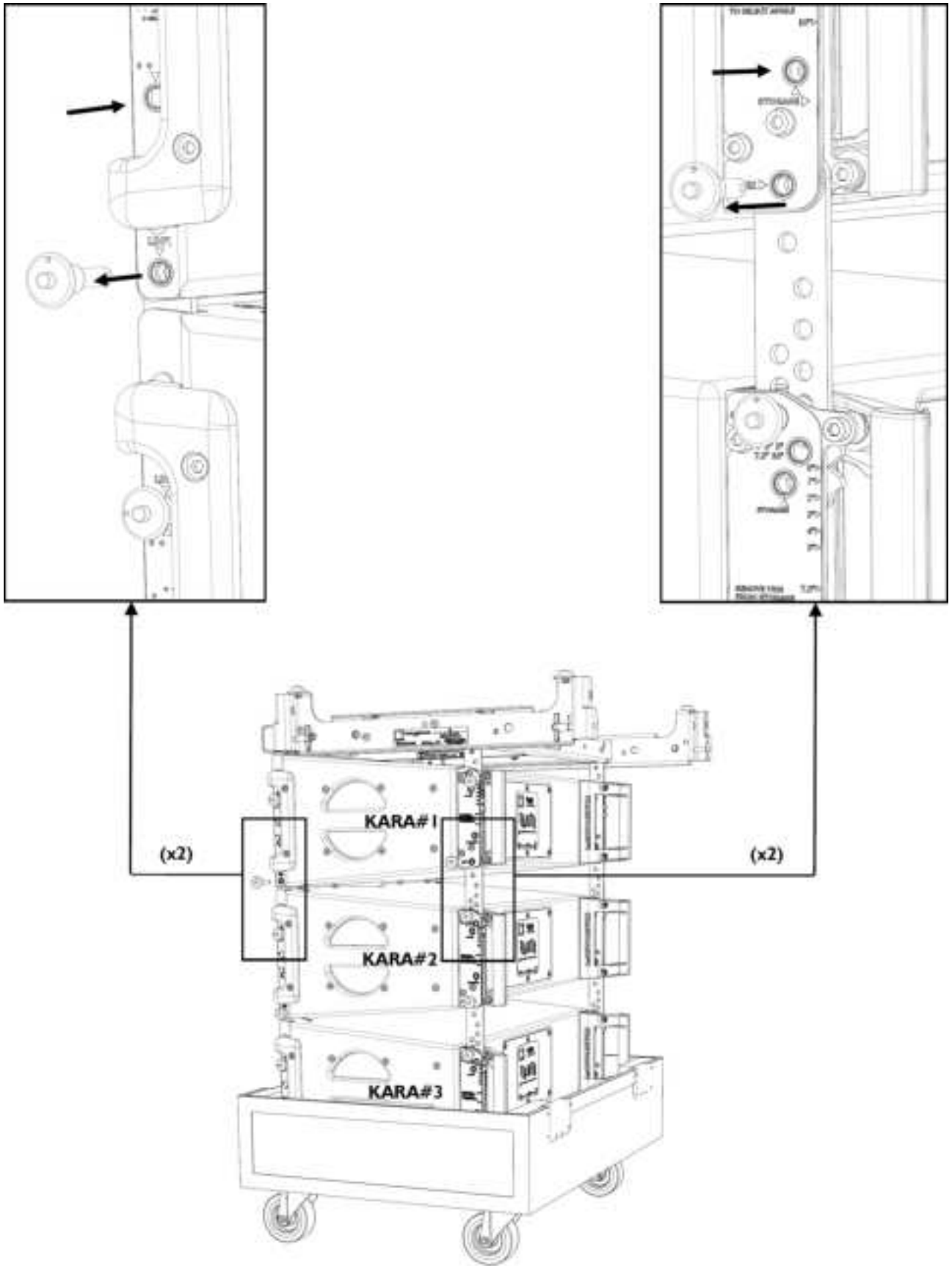

- 13.** Attach the KARA#1/platform assembly to the top SB18 (SB18#2 for example) as follows:
- Turn the assembly feet pointing down and KARA#1 front face towards audience.
 - Position the assembly onto SB18#2 sliding it downwards along the SB18#2 rigging elements.
 - Secure the assembly and SB18#2 link points together by removing the four KARA-MINIBUEX T-BLP from their **storage** holes and re-inserting them into their **link** holes.

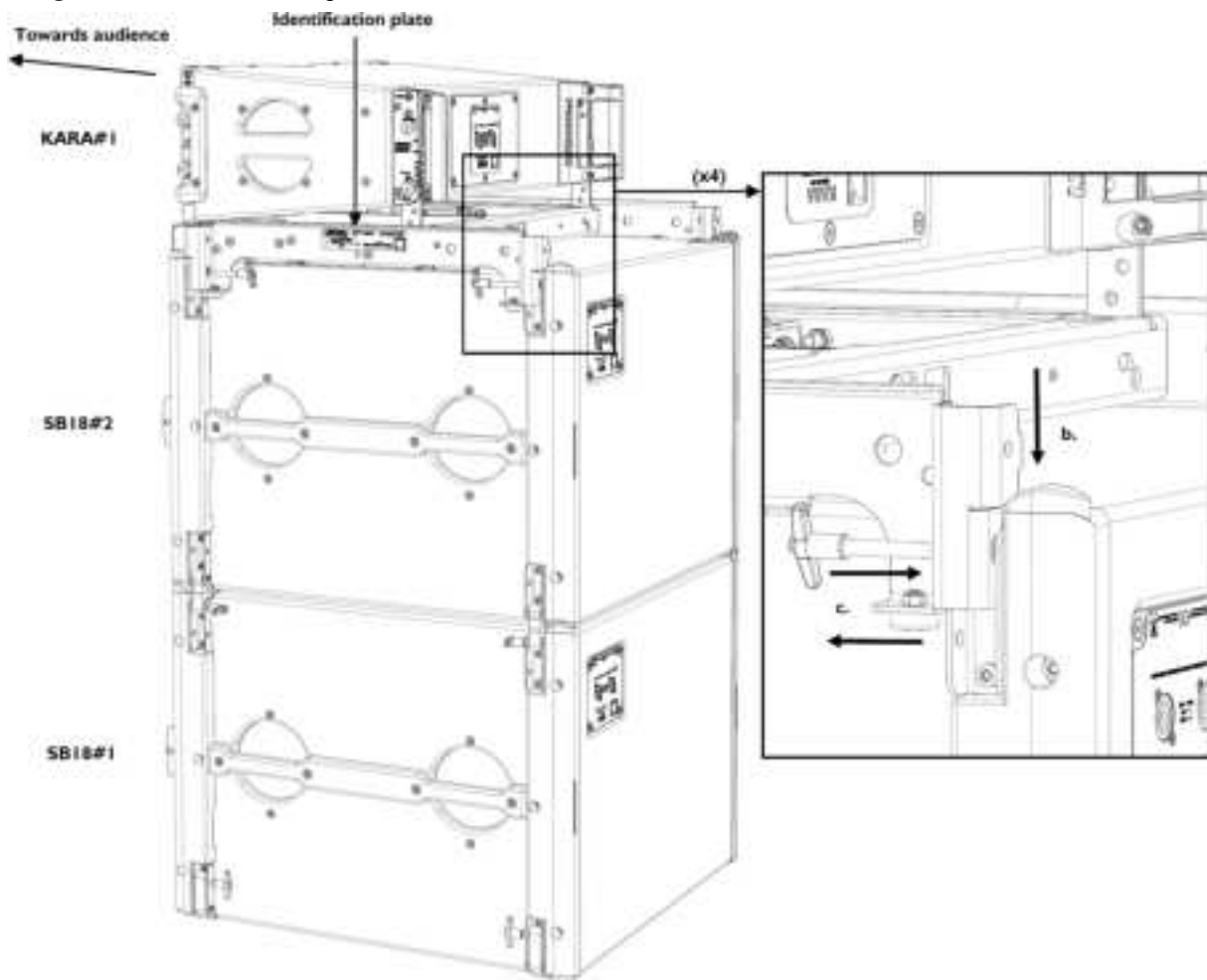

- 14.** Open the four KARA#2 arms by applying step 10 (p.134).
- 15.** Remove the four KARA#2 bottom R-BLP from their **link** holes and re-insert them into their **storage** holes (see step 12 (p.136)).

16. Attach KARA#2 to KARA#1 as follows:

- a) Turn KARA#2 arms pointing down and front face towards the audience.
- b) Align the four arms with the KARA#1 link points.
- c) Secure the link points together by removing the four KARA#1 top R-BLP from their **storage** holes and reinserting them into their link holes.

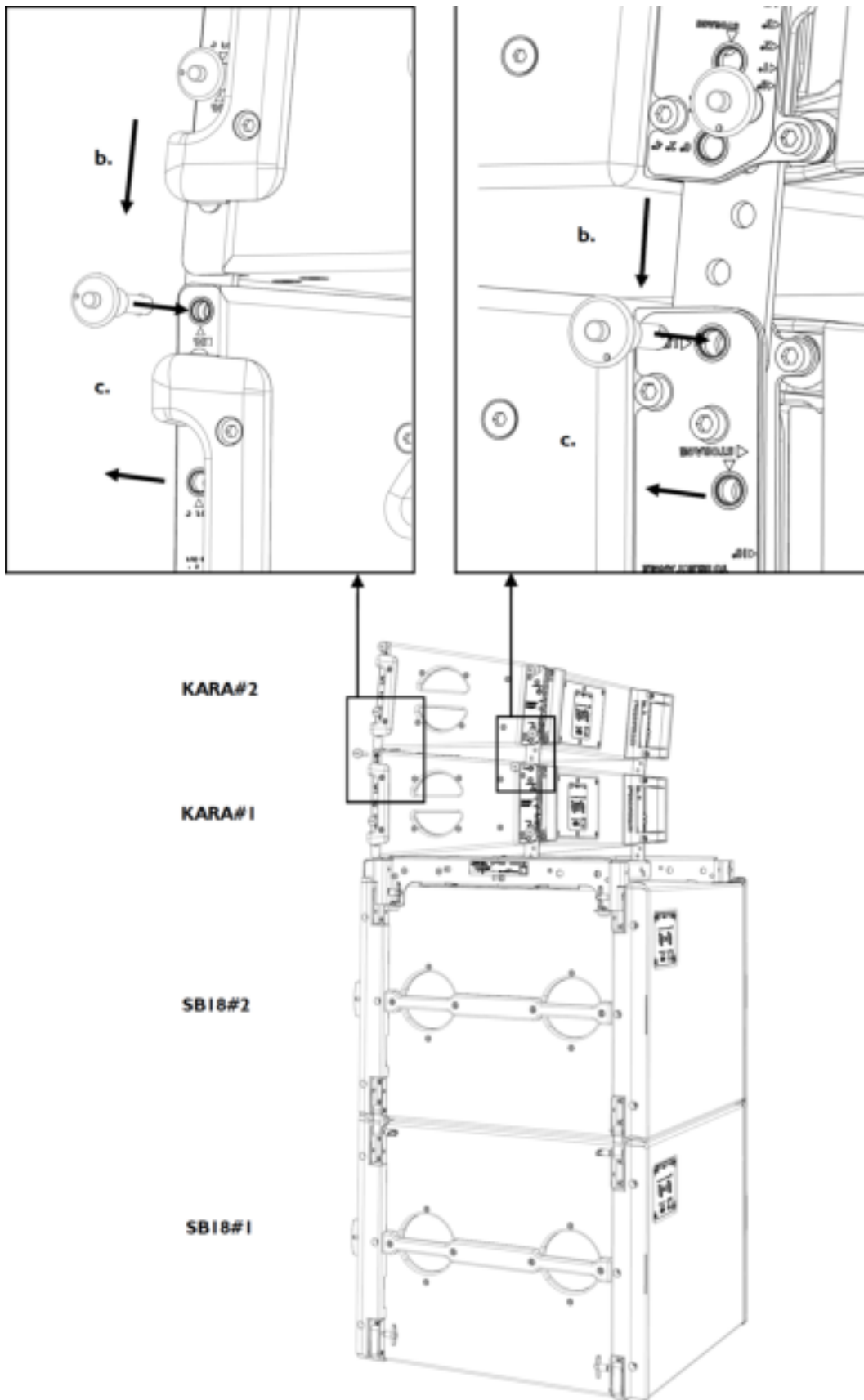

17. Attach KARA#3 to KARA#2 by applying steps 14 (p.137) to 16 (p.138).



- 18.** Using another full Kara II flight-case, repeat steps 14 (p.137) to 16 until all Kara II enclosures composing the array are assembled.



- 19.** Secure the loudspeaker assembly to a fixed point using a ratchet strap or any other equivalent material (not included).

Array removal

About this task

-  All along the procedure:
 Strictly follow the sequence of the successive steps.
 Systematically verify that each BLP is fully inserted.
-  For clarity purposes the loudspeaker cable removal procedure will not be described.
 The loudspeaker cables will not be represented on the figures.

Procedure

1. Detach the ratchet strap or other equivalent material from the stacked array.
2. Bring an empty Kara II flight-case to the rigging location and remove the lid.
3. Remove the top Kara II (KARA#3 for example) from the Kara II below (KARA#2 for example) by removing the four KARA#2 top R-BLP from their **link** holes and re-inserting them into their **storage** holes.

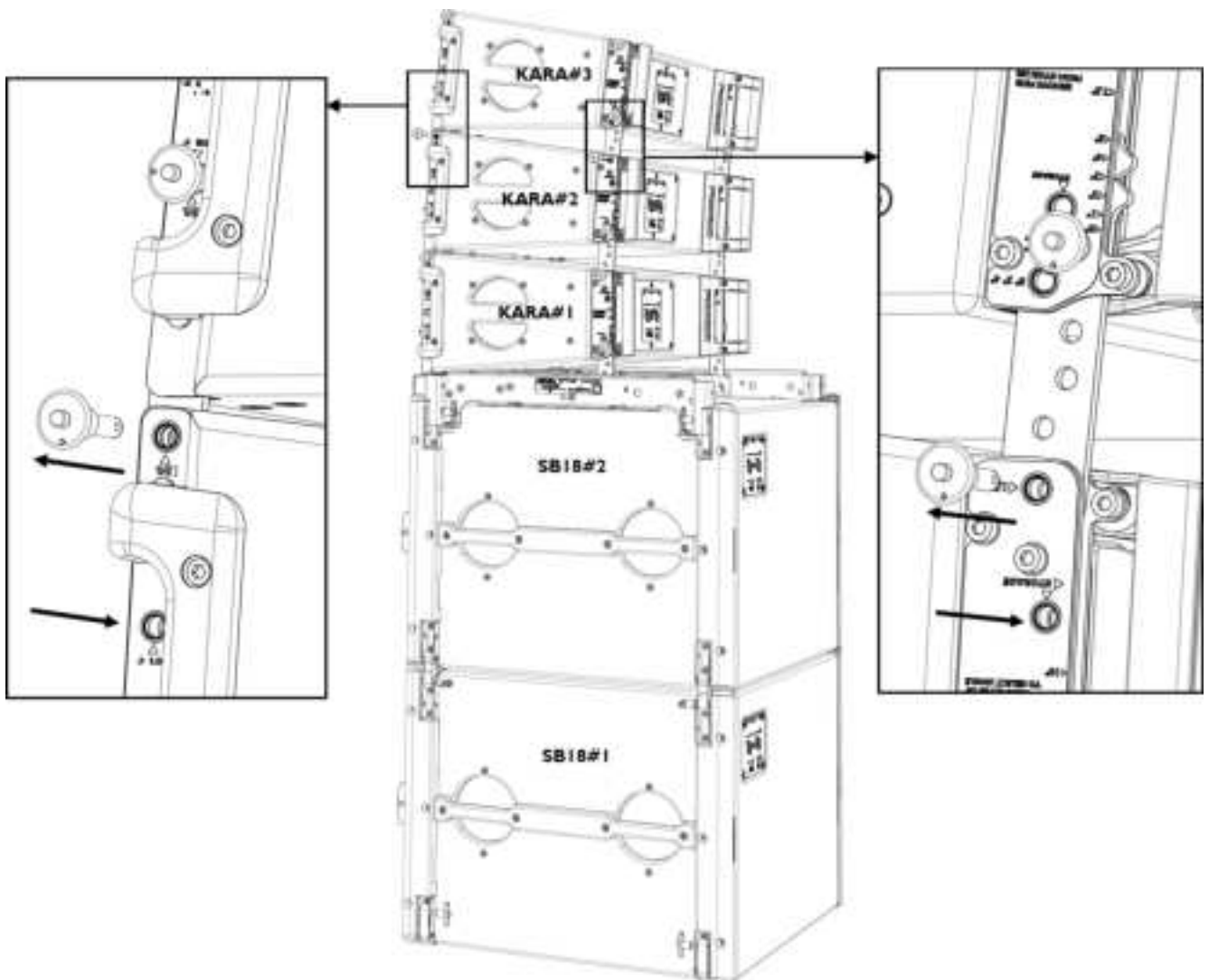

4. Lift up and turn KARA#3 arms pointing up. Put KARA#3 into the flight-case tray.



Pay attention to the tray position: both wedges must slope upwards from front to rear (refer to [Flight-case](#) (p.30)).

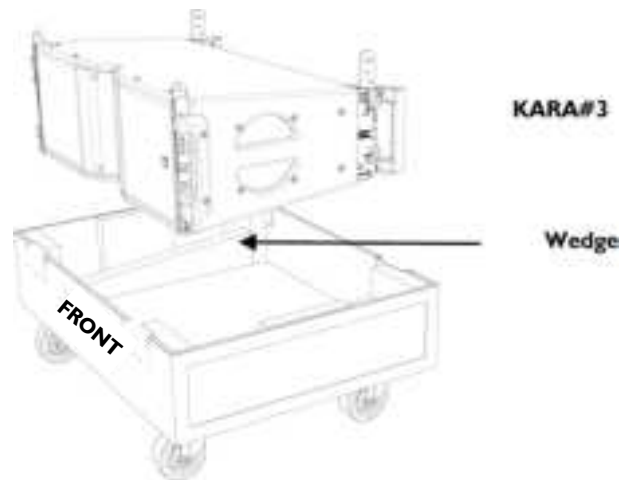

5. Set angle 0° on KARA#3 as follows (repeat on both sides of the enclosure):
- Remove the rear top R-BLP from its angle hole.
 - Slide the angle arm so as to align the cursor with angle label 0° .
 - Lock the arm in place by re-inserting the R-BLP into angle hole $0^\circ/2^\circ/4^\circ$.

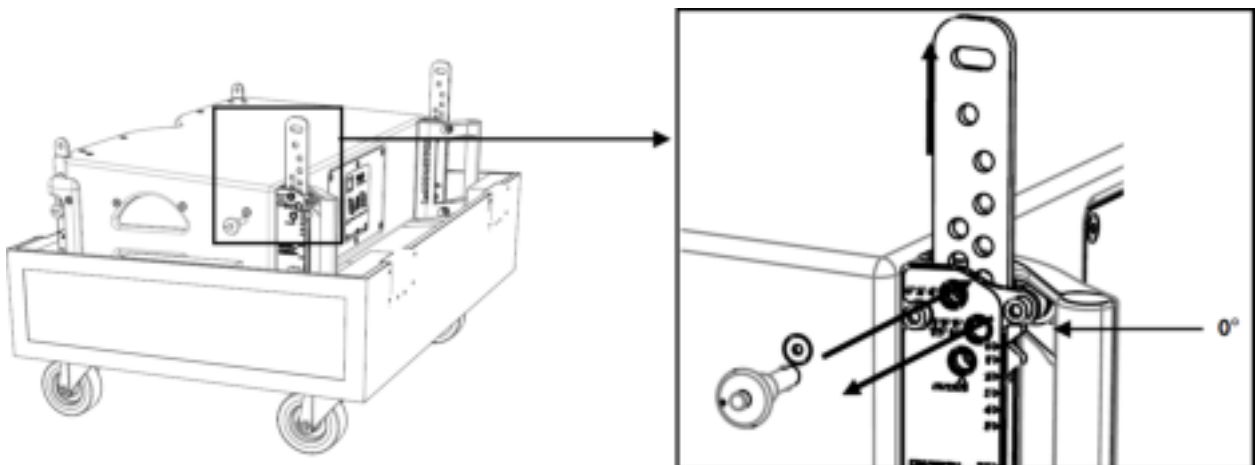

6. Remove KARA#2 from KARA#1 by applying step 3 (p.140).

7. Attach KARA#2 to KARA#3 as follows:

- Lift up and turn KARA#2 arms pointing up.
- Align the front and rear link points between KARA#2 and KARA#3.
- Secure the link points together by removing the four KARA#2 bottom R-BLP from their **storage** holes and reinserting them into their link holes.

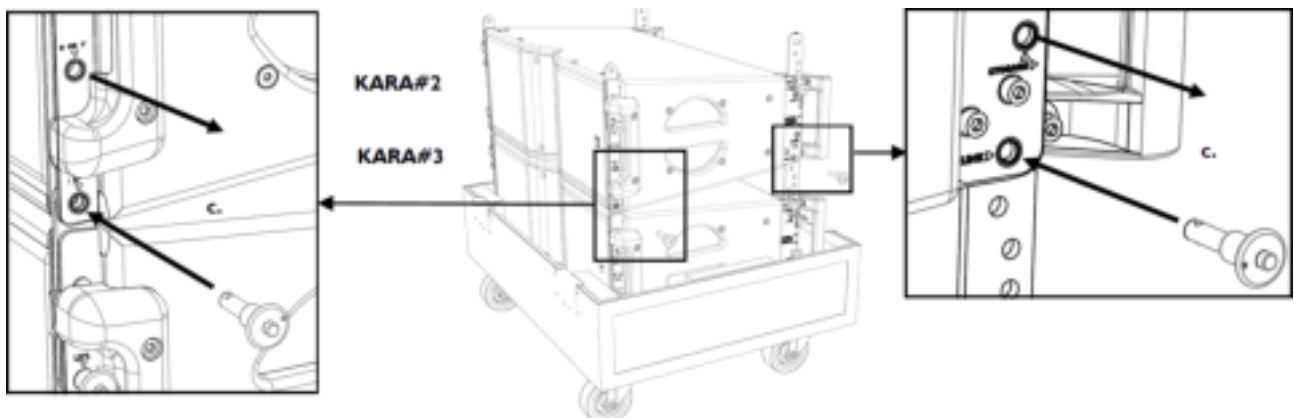

8. Set angle 0° on KARA#2 by applying step 5 (p.141).

9. If the last enclosure to be placed in the flight-case is not attached to the KARA-MINIBU (KARA#4), apply steps 3 (p.140), 7 (p.141), 12 (p.144), and 13 (p.144) for KARA#4 and then apply the procedure a new time from step 2 (p.140) for array KARA#1-3.

If the last enclosure to be placed in the flight-case is attached to the KARA-MINIBU (KARA#1), disconnect the link points between the KARA-MINIBUEX and SB18#2 by removing the four KARA-MINIBUEX T-BLP from their **link** holes and re-inserting them into their **storage** holes.

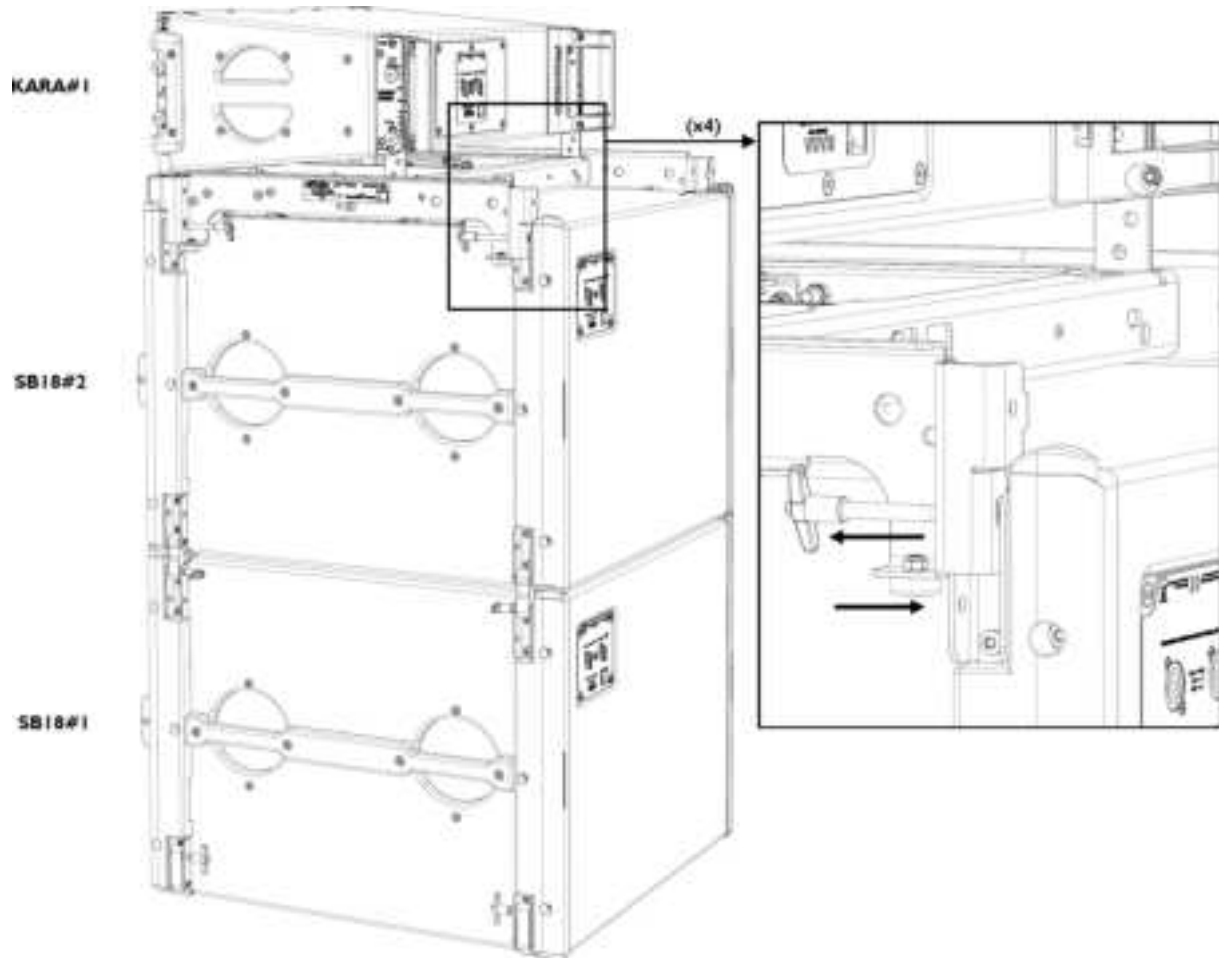

10. Attach the KARA#1/platform assembly to KARA#2 by applying step 7 (p.141).

11. Remove the platform from KARA#1 as follows:

- a) Remove both KARA-MINIBU front R-BLP.
- b) If KARA-ANGARMEX are attached to the platform, remove both T-BLP from them. Otherwise, remove both KARA-MINIBU rear R-BLP.
- c) Separate the platform from KARA#1.
- d) If KARA-ANGARMEX are attached to the platform, remove them by removing both KARA-MINIBU rear R-BLP.
- e) Re-insert the four R-BLP into the KARA-MINIBU holes.

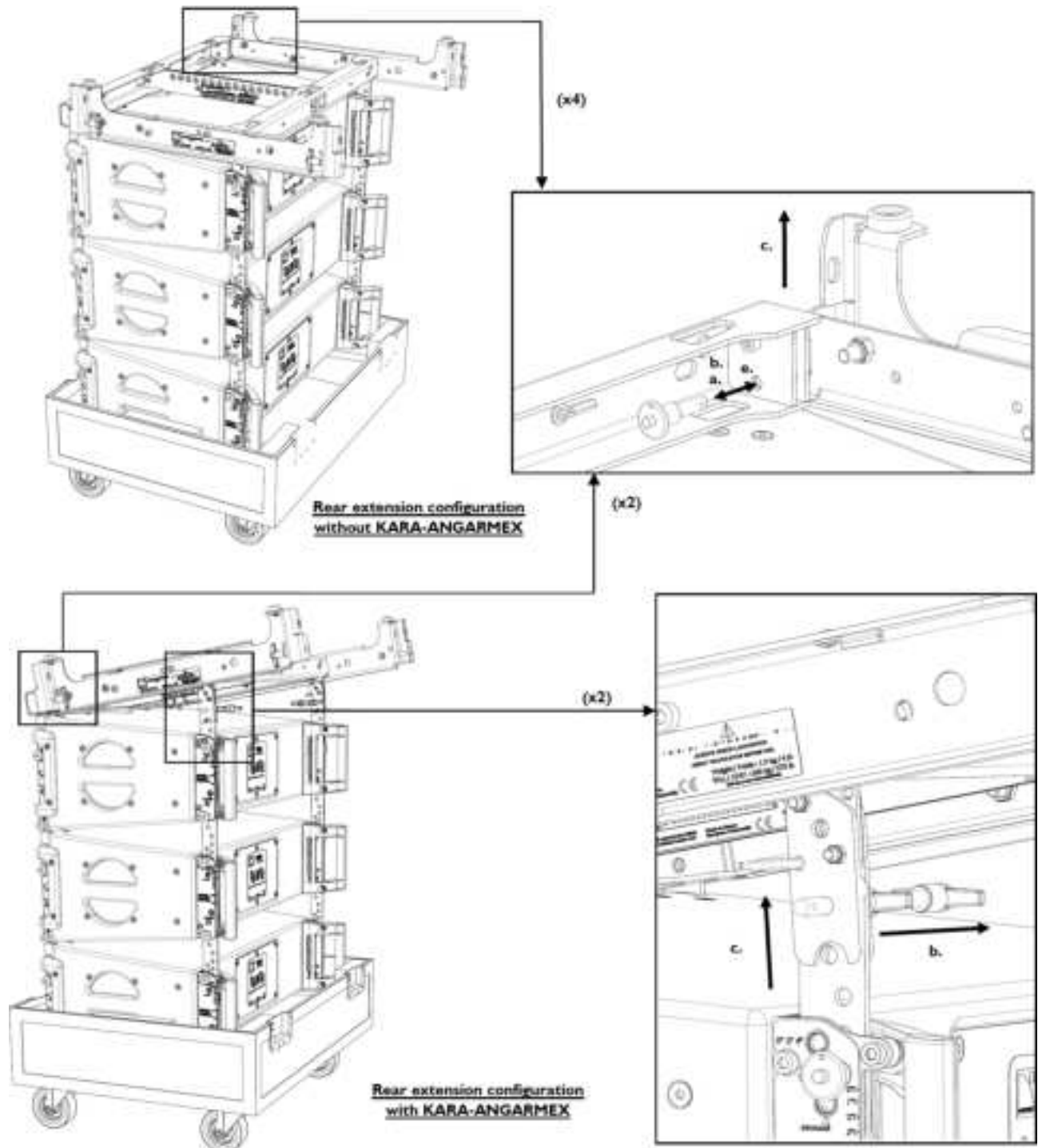

12. Close the four KARA#1 arms as follows (repeat on both sides of the enclosure):

- a) Remove the front top R-BLP from its **link** hole, slide the front arm up, rotate it down, and lock it in place by re-inserting the R-BLP into its **storage** hole.

i The front top **storage** and **link** holes are the same.

- b) Remove the rear top R-BLP from its angle hole, slide the angle arm so as to align the cursor with the storage label, and lock it in place by re-inserting the R-BLP into its **storage** hole.

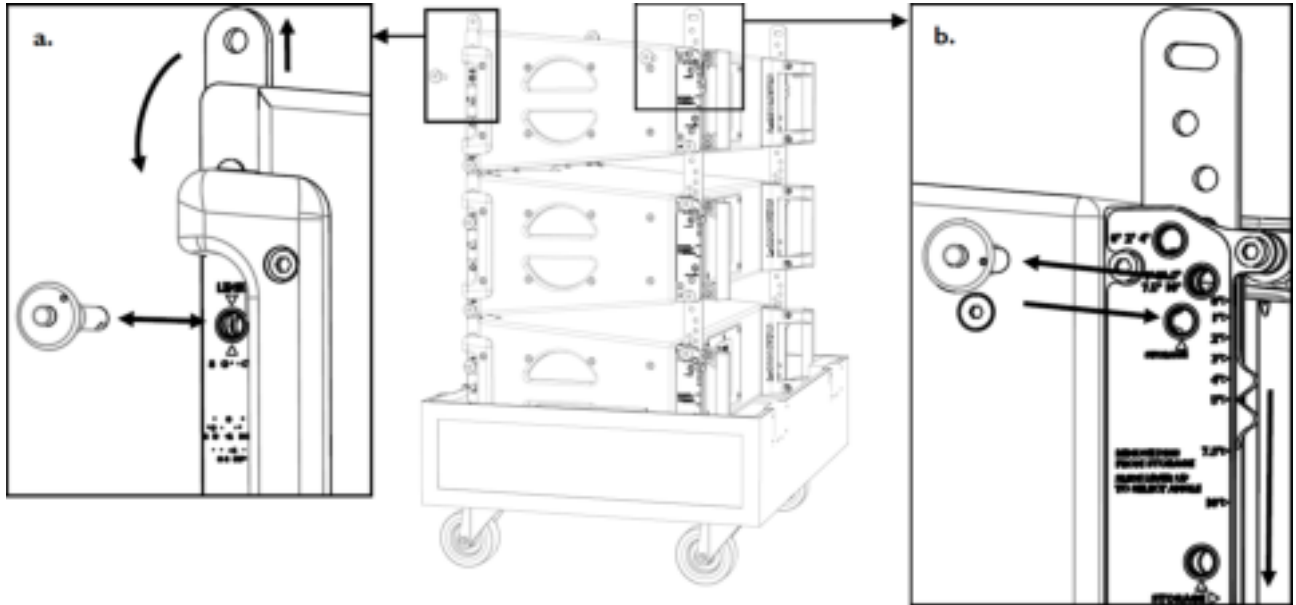

13. Attach the lid to the flight-case.

14. Remove the top SB18 (SB18#2 for example) from the SB18 below (SB18#1 for example) as follows:

- a) Remove a top T-BLP from SB18#1.
- b) Rotate the link arm up.
- c) Lock the link arm in closed position by re-inserting the T-BLP into SB18#2.
- d) Repeat this procedure until all four arms are locked in closed position.

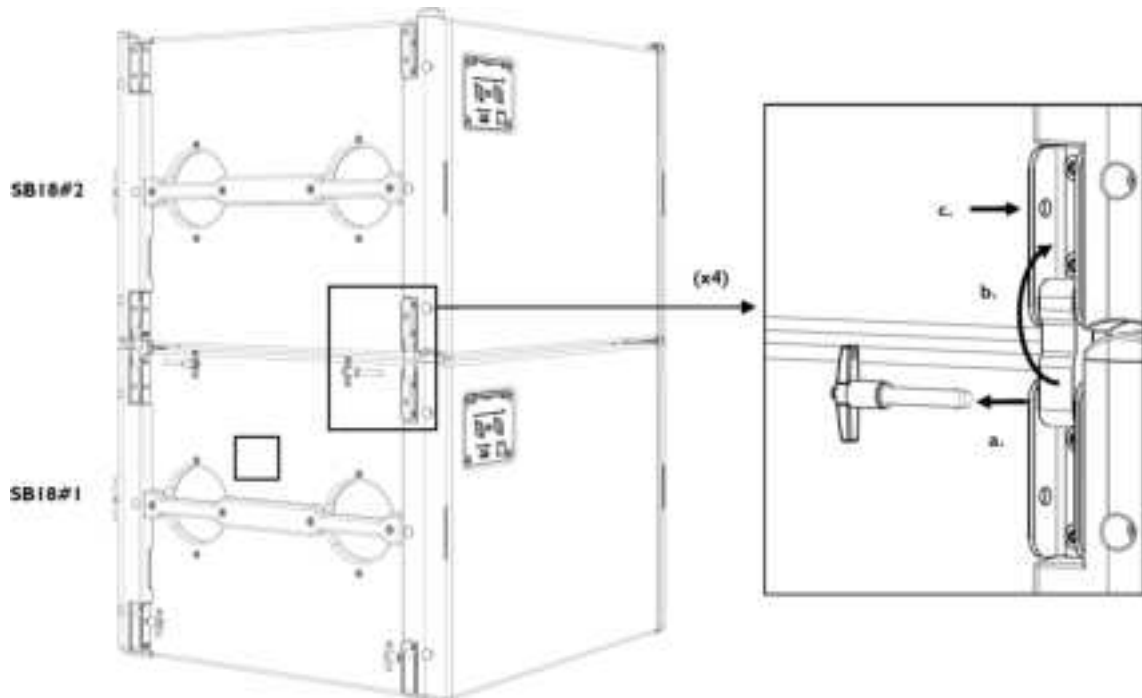

15. Attach a dolly board to SB18#2 and remove SB18#2 from the rigging location.

16. Repeat steps 14 (p.144) and 15 (p.144) until all SB18 of the array are disassembled.

Connection to LA amplified controllers

! Refer to the **Amplification reference** technical bulletin for the latest information on compatibility with amplified controllers and cabling schemes for all enclosure types.

Enclosure drive capacity per amplified controller

Make sure the total number of connected enclosures does not exceed the maximum number of enclosures per controller (refer to the footnotes).

	LA4X	LA8	LA12X
	per output[*] / total	per output[*] / total	per output[*] / total
Kara II	2 / 4	3 / 6	3 / 6
SB18	1 / 4	2 / 6**	3 / 12

Cabling schemes

Cabling schemes for Kara II

Refer to the cabling schemes to connect the enclosures to different types of output connectors.

Two-channel speakON output

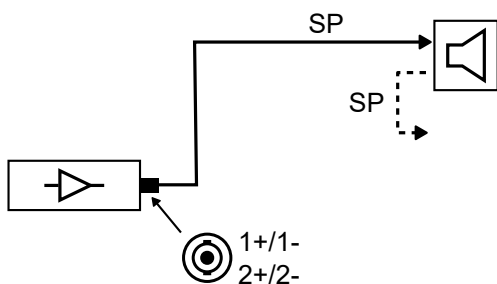

Four-channel CA-COM output

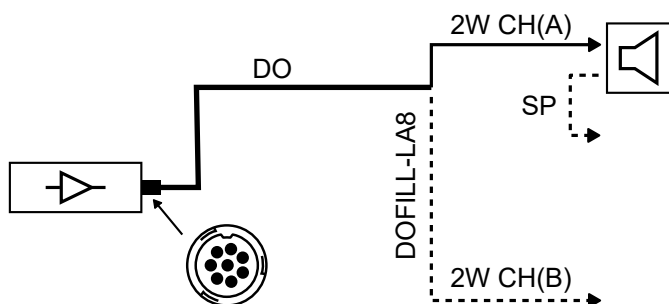

Four-channel CA-COM output for one Kara II and two subwoofers

* For passive loudspeakers, the value corresponds to the number of enclosures in parallel on the output. For active loudspeakers, the value corresponds to the number of sections in parallel on the output.

** LA8 can drive up to two SB18 per output, but no more than six per controller at high level.

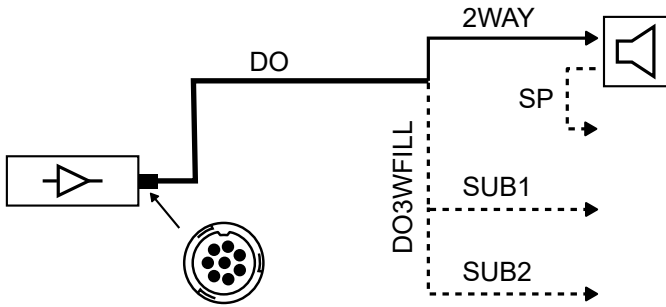

Cabling schemes for SB18

Refer to the cabling schemes to connect the enclosures to different types of output connectors.

One-channel speakON output

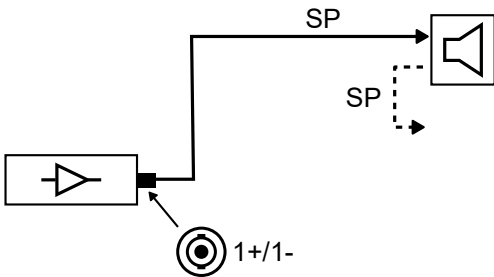

Two-channel speakON output

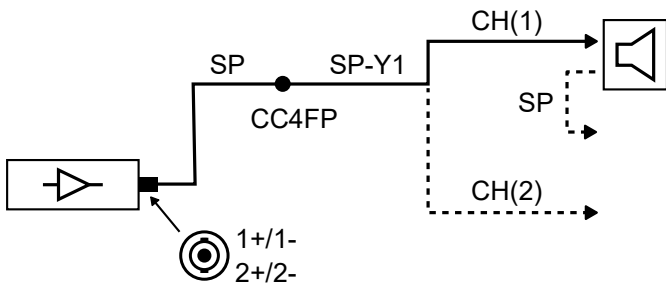

Four-channel CA-COM output

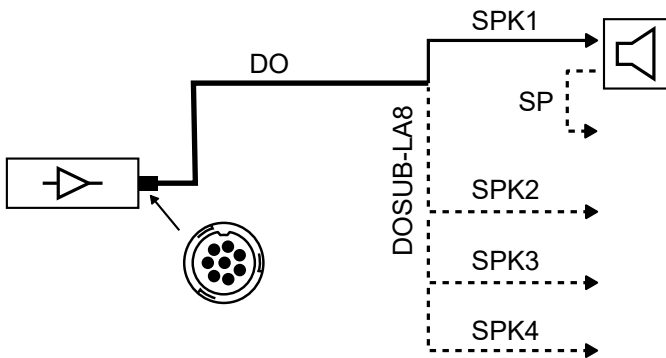

Corrective maintenance

Introduction

This section contains the following maintenance procedures:

Kara II

- [Grill](#) (p.151)
- [Fins](#) (p.152)
- [LF speaker](#) (p.153)
- [Connector plate](#) (p.154)
- [HF driver](#) (p.155)
- [HF diaphragm](#) (p.156)

SB18

- [Grill](#) (p.159)
- [LF loudspeaker](#) (p.160)
- [Pins](#) (p.164)

M-BUMP

- [Rigging pins \(long\)](#) (p.169)
- [Rigging pins \(short\)](#) (p.170)
- [Laser support plate](#) (p.171)

M-BAR

- [Rigging pins](#) (p.173)

KARA-MINIBU

- [Laser support plate](#) (p.175)

KARA-MINIBUEX

- [Rigging pins](#) (p.177)
- [Rubber feet](#) (p.178)

For advanced maintenance, contact your L-Acoustics representative.

Tools and consumables

Before performing maintenance on this product, make sure all the tools listed are available. Reference are given for FACOM® products in this table. Other manufacturers can be used.

Name	Reference	Distributor
Set of 6-point 1/4" sockets *	RL.NANO1 / R.360NANO	FACOM
Torque screwdriver (2 - 10 N.m) *	A.404	FACOM
riveting pliers	Y.103B	FACOM
3 mm hex wrench	-	-
10 mm wrench	-	-
blue threadlocker	-	-
compressed air blower	-	-

 * included in the L-Acoustics Maintenance Toolcase.

Maintenance Toolcase

The Maintenance Toolcase is a carry-on suitcase that includes all the tools required to perform maintenance on L-Acoustics products. This toolcase is aimed at Certified Providers.

The Maintenance Toolcase uses a Peli™ 1510 Protector case that features three pre-cut layers of foam to safely fit the tools. The Maintenance Toolcase includes tools manufactured by FACOM®, Fluke®, Tohnichi, ABUS, and Würth.

 All third-party trademarks, registered trademarks, or product names are the property of their respective owners.

Kara II

Kara II exploded views

In order to operate, follow the order outlined here. Each assembly refers to the corresponding Disassembly/Reassembly (D/R) procedure and the necessary repair kit.

Checking KR compatibility

The G03521 and G03520 repair kits are compatible only with Kara II(i) and not with Kara enclosures that were upgraded to Kara II using the KARA II UPG kit.

To ensure compatibility, check the product serial number :

Serial numbers starting with 2190xxxxxx: use G03521 / G03520.

Serial numbers starting with 0770xxxxxx: use KR HPBC34 / KR HSBC34. Refer to the **Kara owner's manual** for instructions.

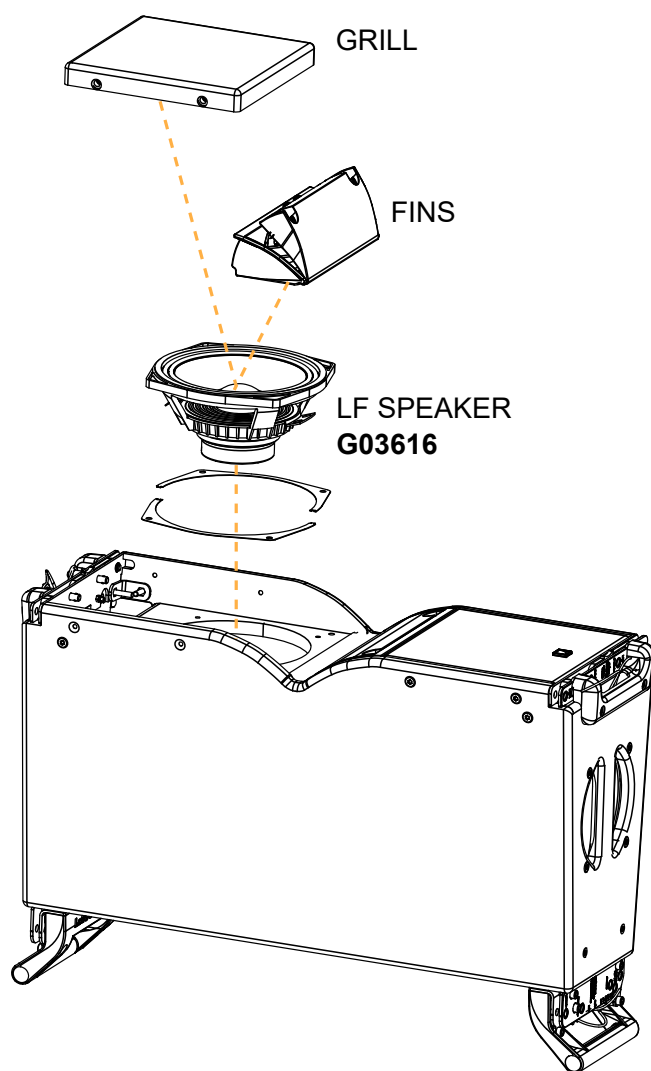

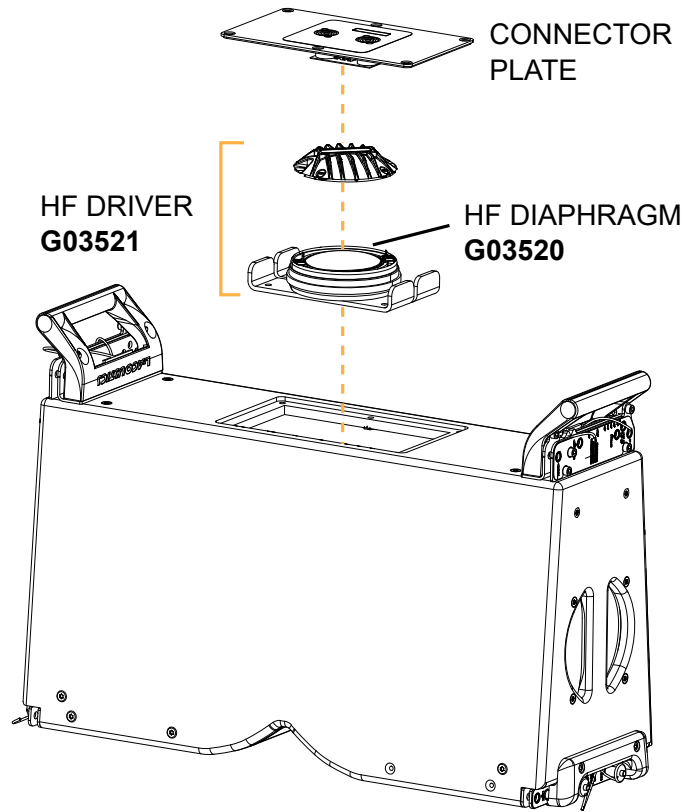

Disassembly and Reassembly procedures

D/R - Grill

Tools

- torque screwdriver
- T30 Torx bit

Repair kit

G03616

KR loudspeaker 8" Kara(i) / Kara II(i)

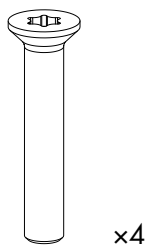

S221

M6x35 Torx

Exploded view

- !** For safety reasons, always use the new screws and spare parts provided in the KR.
If no new screws are available, use blue threadlocker.

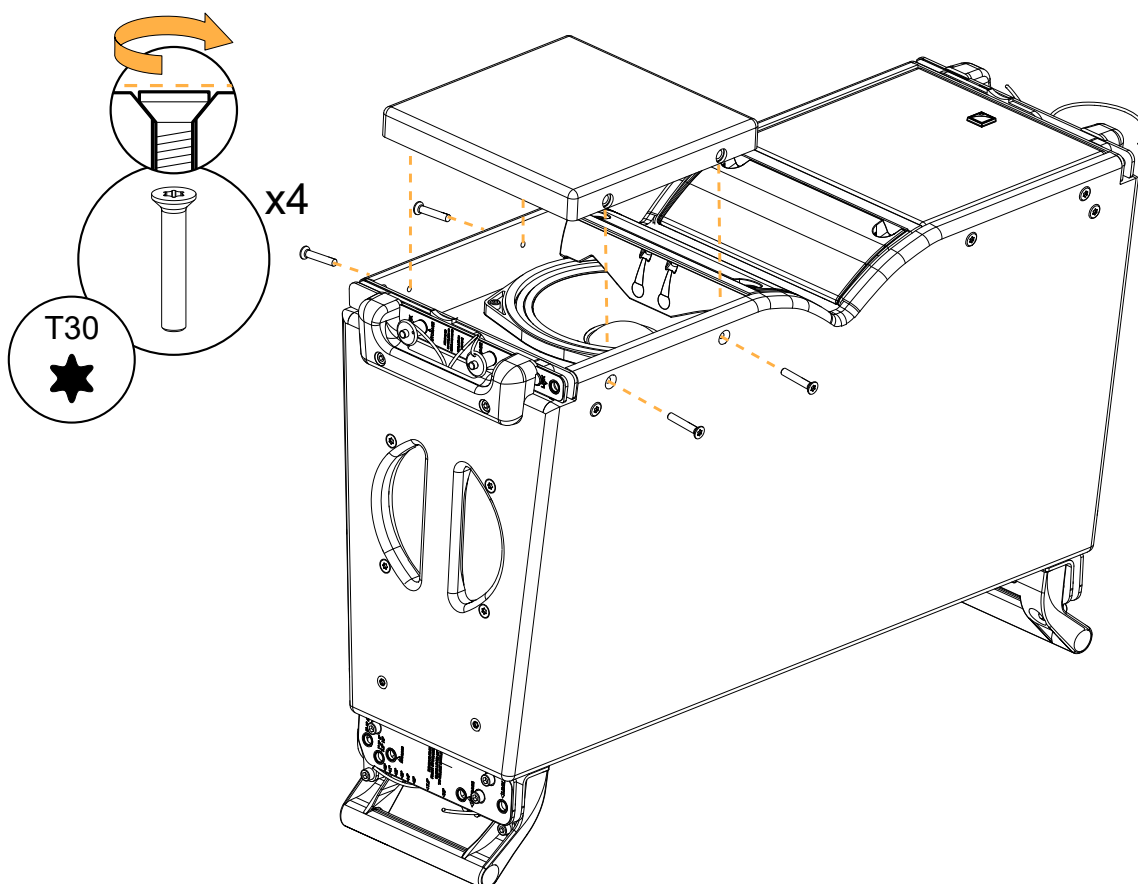

D/R - Fins

Tools

- torque screwdriver
- T30 Torx bit
- flat plastic tool

Repair kit

G03616

KR loudspeaker 8" Kara(i) / Kara II(i)

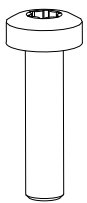

x2

S100143

M6x25 Torx

Exploded view



For safety reasons, always use the new screws and spare parts provided in the KR.
If no new screws are available, use blue threadlocker.



Use a flat tool made of **smooth plastic** to avoid scratching the fins.

Use the flat tool to unhook the fin clips.

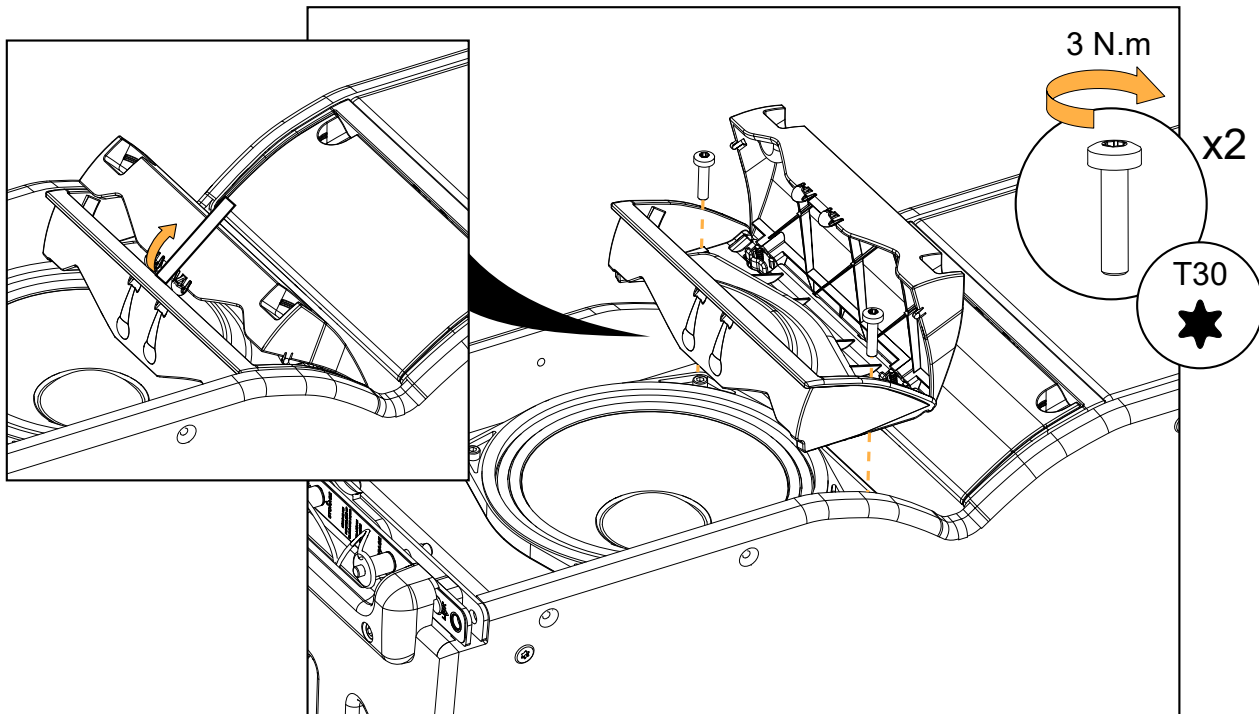

D/R - LF speaker**Tools**

- torque screwdriver
- T25 Torx bit

Repair kit**G03616**

KR loudspeaker 8" Kara(i) / Kara II(i)

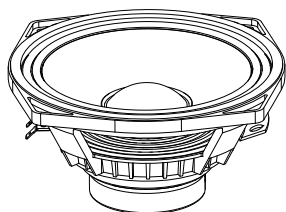

x1

18178

8" LF/MF speaker - 16 Ω



x4

S100228

M5x25 Torx

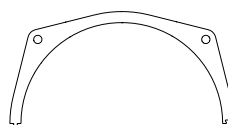

x2

1707

8" speaker gasket

Prerequisite

Grill removed.

See [Grill](#) (p.151).

Fin removed.

See [Fins](#) (p.152).**Exploded view**

For safety reasons, always use the new screws and spare parts provided in the KR.
If no new screws are available, use blue threadlocker.



If the speaker gasket is damaged, remove and replace it.

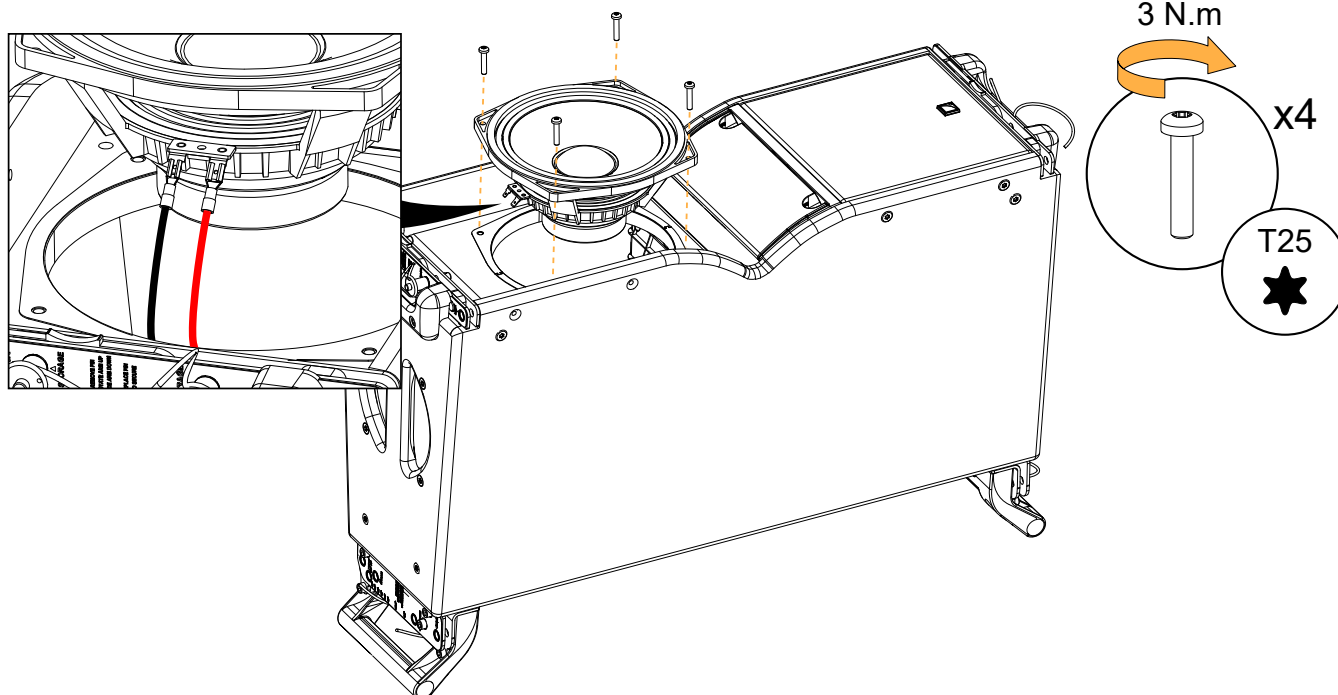

D/R - Connector plate

Tools

- torque screwdriver
- T30 Torx bit

Repair kit

**G03521 - KR compression driver 3" Kara II(i) or
G03520 - KR diaphragm for 3" driver Kara II(i)**

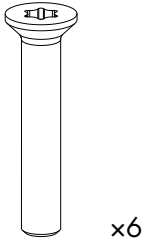

S221

M6x35 Torx

Exploded view

 For safety reasons, always use the new screws and spare parts provided in the KR.
If no new screws are available, use blue threadlocker.

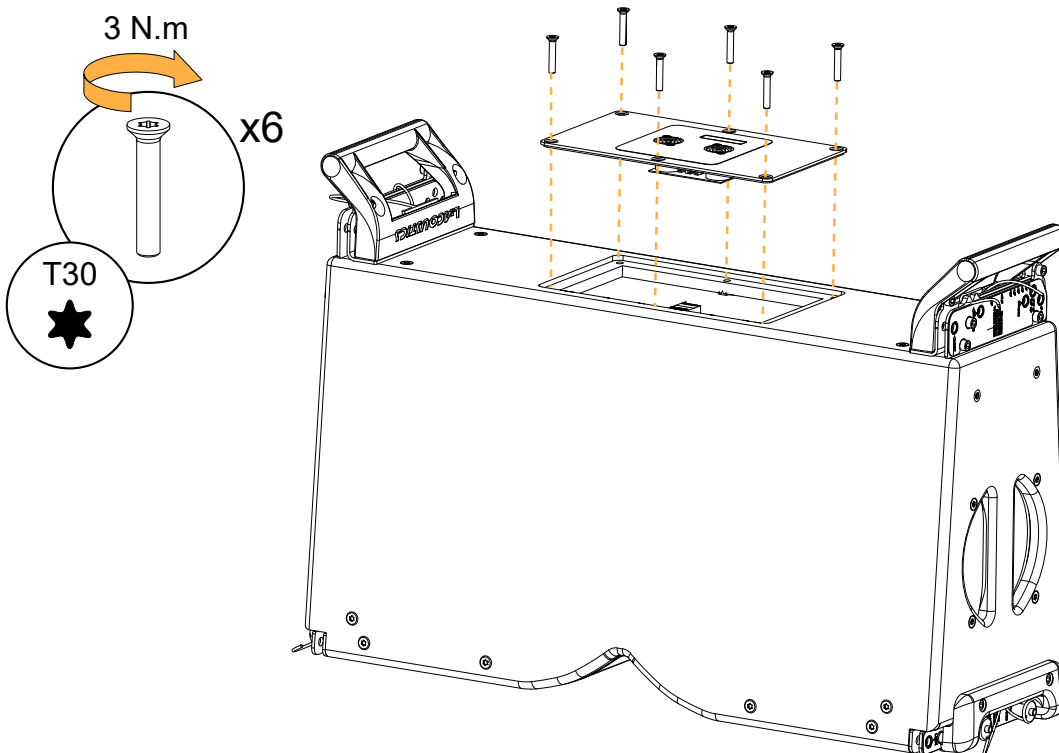

D/R - HF driver**Tools**

- torque screwdriver
- 5 mm hex bit
- T30 Torx bit

Repair kit**G03521 ***

KR compression driver 3" Kara II(i)

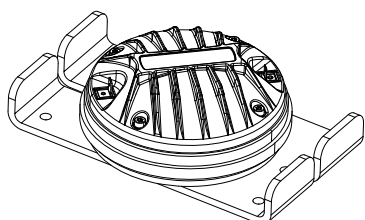

x1

D17986

3" HF driver - 8 ohms assembly

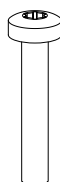

x2

S247

M6x35 Torx



* The screws and fasteners are also provided in G03520 (KR diaphragm for 3" driver Kara II(i)).

Prerequisite

Connector plate removed.

See [Connector plate](#) (p.154).

Exploded view

For safety reasons, always use the new screws and spare parts provided in the KR.
If no new screws are available, use blue threadlocker.

**HF driver screws update**

Use the 5 mm hex bit to remove the existing screws and the T30 Torx bit to secure the new screws.

Carefully disconnect the cables before removing the driver assembly.

Use the positive (red) connector as a reference point to position the driver assembly.

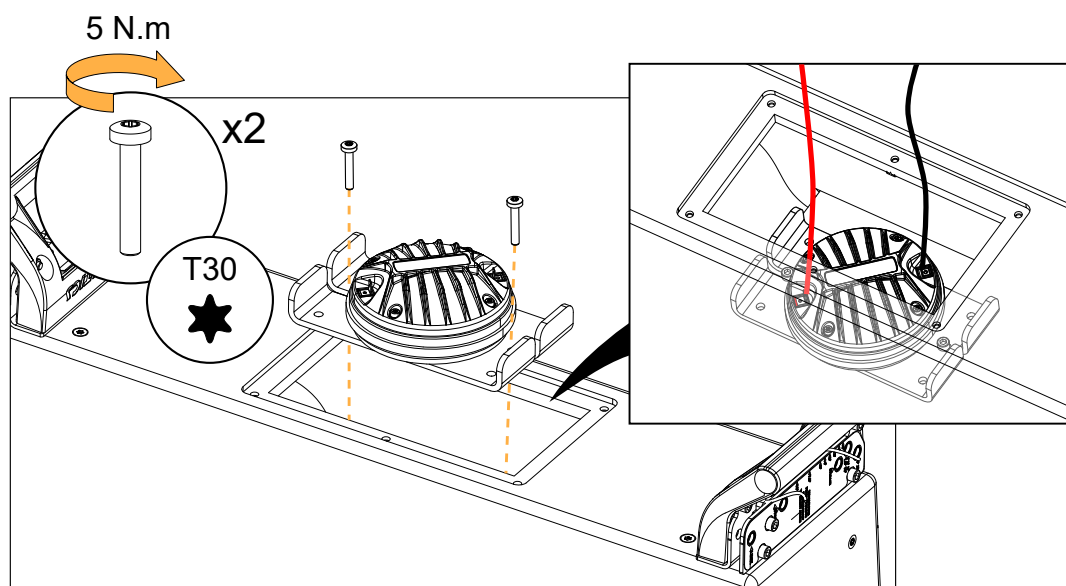

D/R - HF diaphragm

Tools

- torque screwdriver
- T20 Torx bit
- 3 mm hex bit
- compressed air blower

Repair kit

G03520

KR diaphragm for 3" driver Kara II(i)

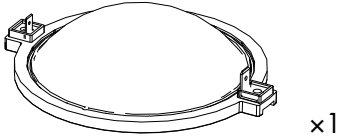

x1

17581

diaphragm assembly (with 2 shims)



x4

S100082

M4x14 hex

Prerequisite

Connector plate removed.

HF driver removed from the cabinet.

The driver is placed on a flat surface in a dust-free environment.

See [Connector plate](#) (p.154).

See [HF driver](#) (p.155).

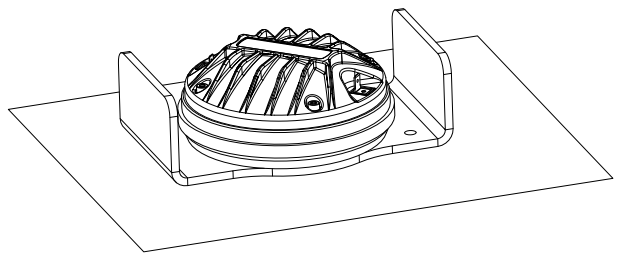

Disassembly

Procedure

1. Remove the four screws securing the cover.
Use the T20 Torx bit.
2. Remove the cover.
3. Carefully remove the diaphragm.
4. If there are shims on the dome, carefully remove them.
Take note of how many and what kind of shims are present.

Reassembly

About this task



For safety reasons, always use the new screws and spare parts provided in the KR.

Procedure

1. Clean the dome and the air gap.



Make sure the air gap is perfectly clean before reassembly.

Use a blower or double face adhesive to remove any particle.

2. Place the same kind and number of shims that were initially present.
3. Carefully place the diaphragm, using the positive (red) connector as reference point.
4. Position the cover and turn it to align it with the screw holes.



Gradually tighten the screws following a star pattern.

5. Secure the cover using four S100082 screws.
Use the 3 mm hex bit. Set the torque to 3 Nm.

What to do next

Perform the [Acoustical check](#) (p.50) procedures.

SB18

Exploded view

In order to operate, follow the order outlined here. Each assembly refers to the corresponding Disassembly/Reassembly (D/R) procedure and the necessary repair kit.

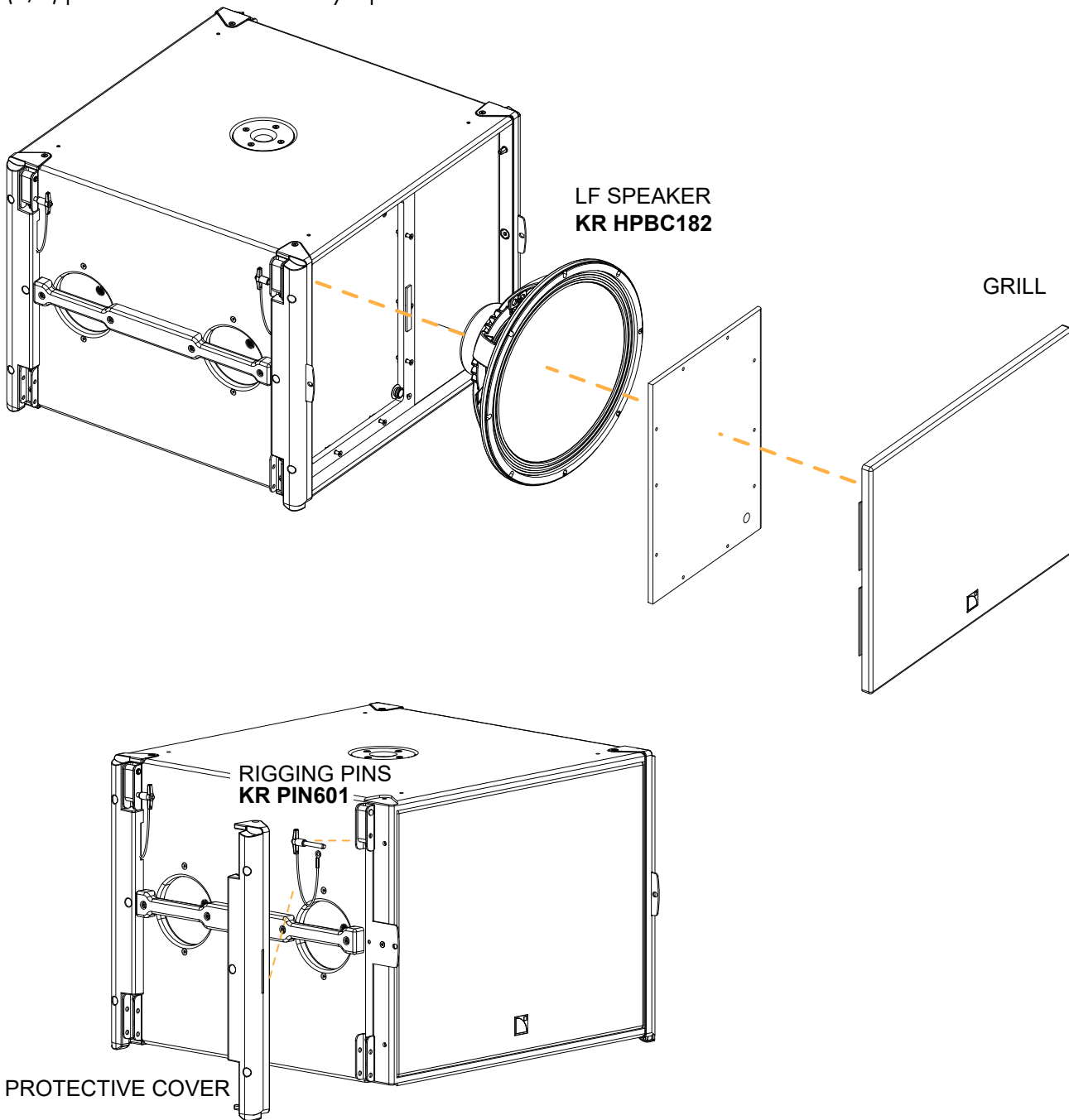

Disassembly and Reassembly procedures

D/R - Grill

Tools

- torque screwdriver
- T30 Torx bit

Repair kit

KR HPBC182

KR 18" loudspeaker SB18(i) / SB18 Ili

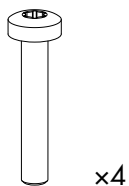

S247

M6x35 Torx

Exploded view



For safety reasons, always use the new screws and spare parts provided in the KR.
If no new screws are available, use blue threadlocker.

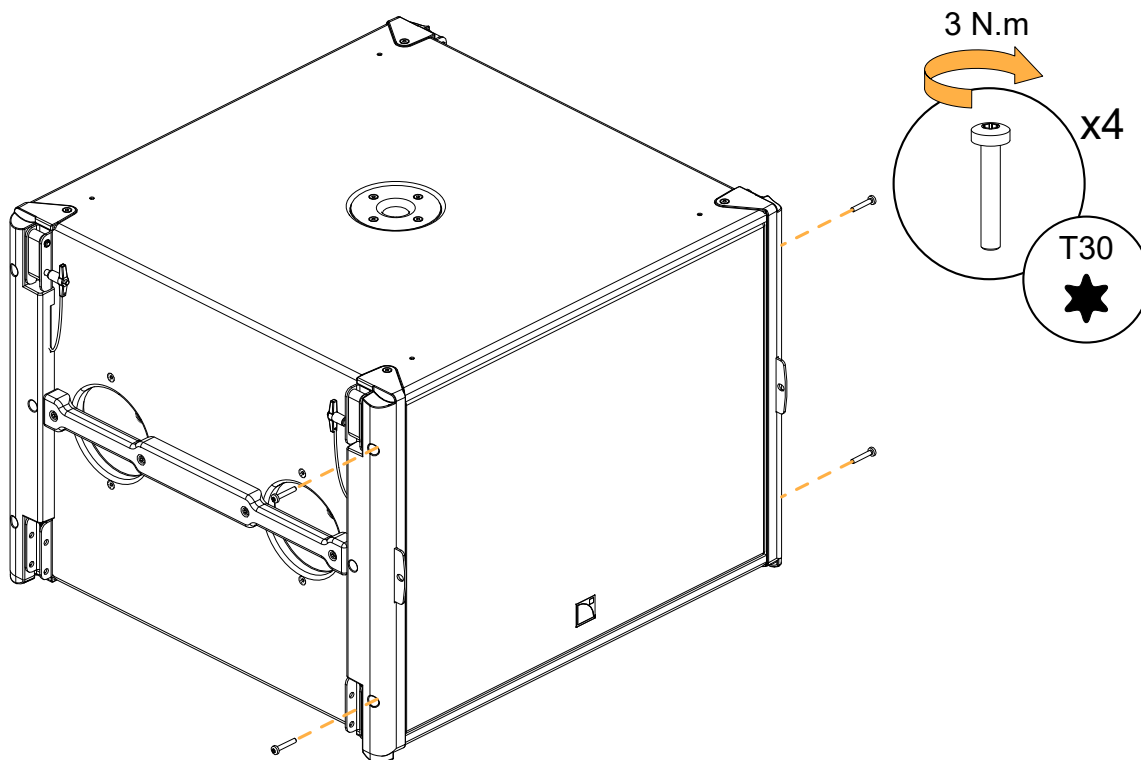

D/R - LF loudspeaker

Tools

- torque screwdriver
- T30 Torx bit
- 5 mm hex bit
- blue threadlocker

Repair kit

KR HPBC182

KR 18" loudspeaker SB18(i) / SB18 Ili

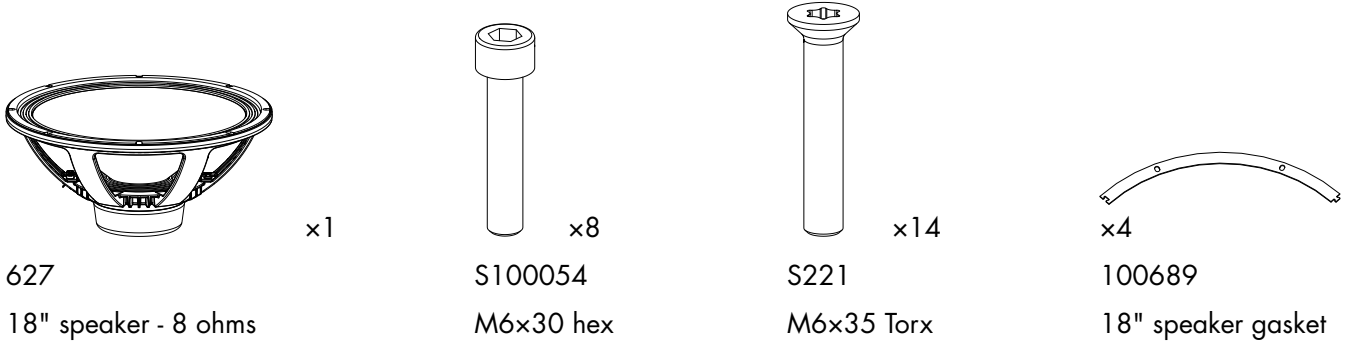

Prerequisite

Grill disassembled.

See [Grill](#) (p.159).

Disassembly

Procedure

1. Remove the plate.

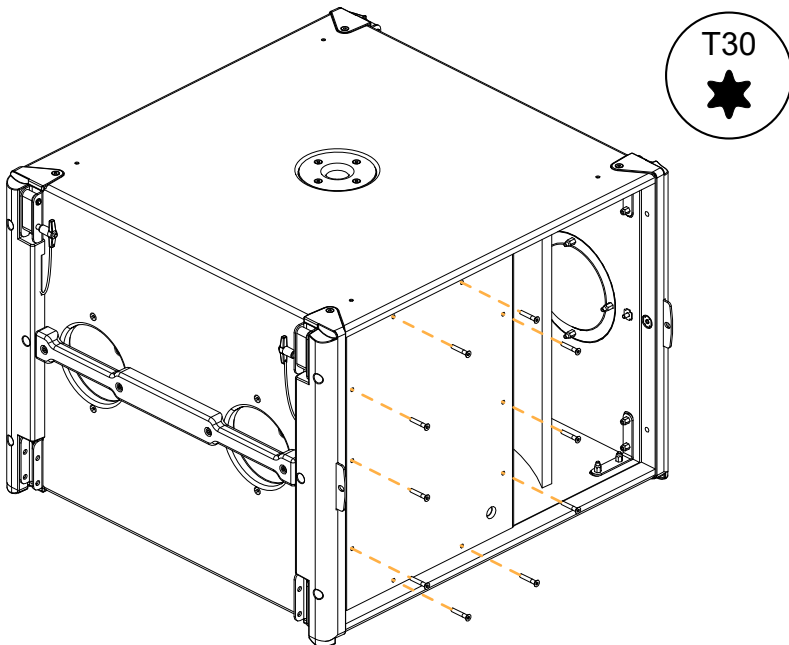

2. Remove the screws securing the speaker.

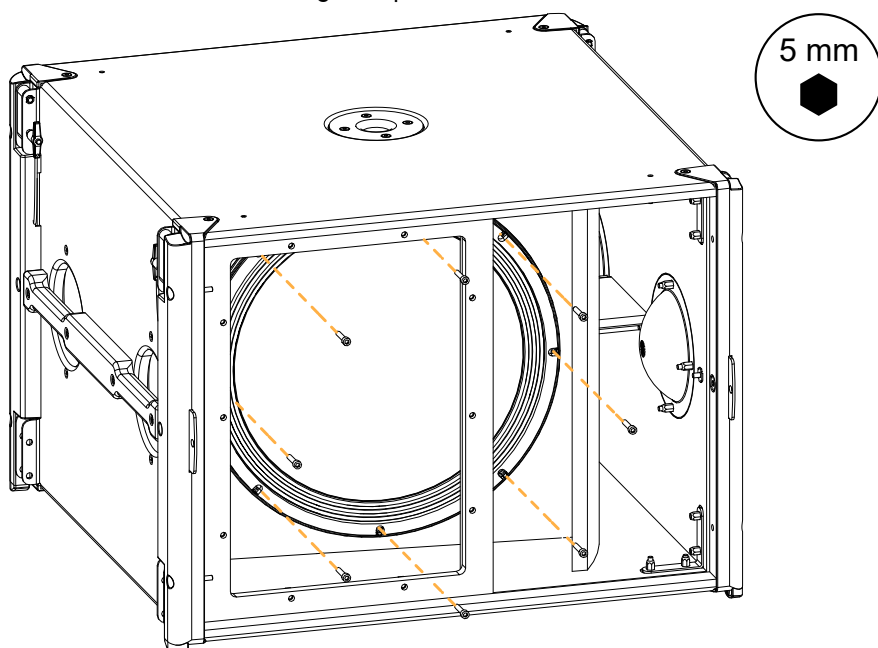

3. Remove the speaker from the enclosure and disconnect the speaker cables.

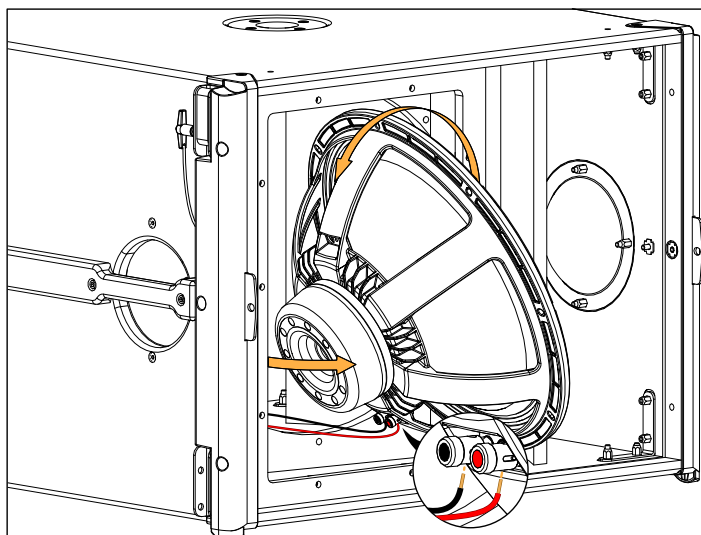

4. If the speaker gaskets are damaged, remove and replace them.

Reassembly

About this task

- ❗ For safety reasons, always use the new screws and spare parts provided in the KR. If no new screws are available, use blue threadlocker.

Procedure

1. Stick the gasket on the cabinet.
2. Connect the speaker cables and position the speaker in the enclosure.

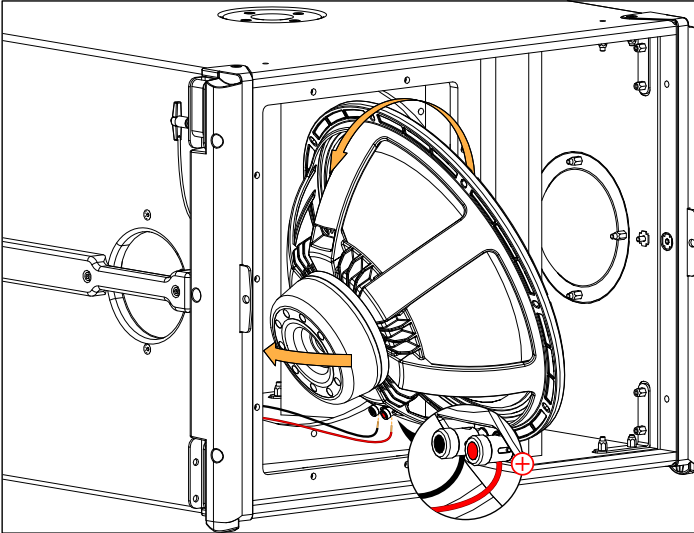

3. Secure the speaker.

- ❗ Gradually tighten the screws following a star pattern.

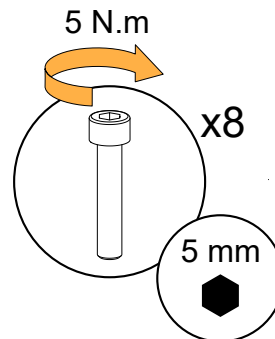
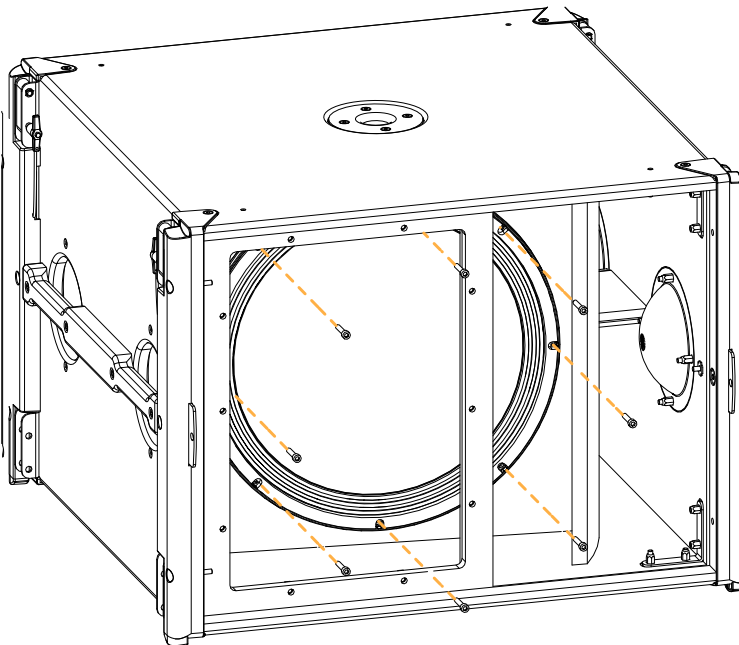

4. Secure the plate.

 Gradually tighten the screws following a star pattern.

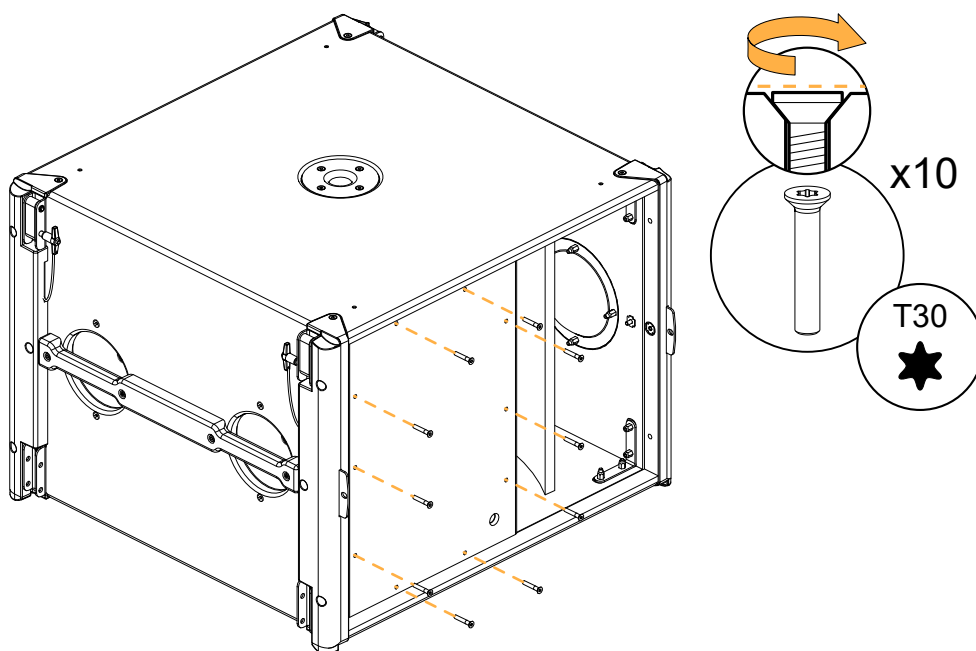

D/R - Pins

Tools

- torque screwdriver
- T30 Torx bit
- blue threadlocker

Repair kit



For safety reasons, always use the new screws and spare parts provided in the KR.
If no new screws are available, use blue threadlocker.

KR PIN601

Kit 10 pins long T-shaped head screws & rivets



x20

S142

M4x10 rivet

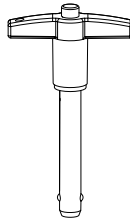

x10

601

ball-locking pin Ø5/16" with lanyard

Disassembly

Procedure

1. Remove the five screws securing the protective cover to the cabinet.

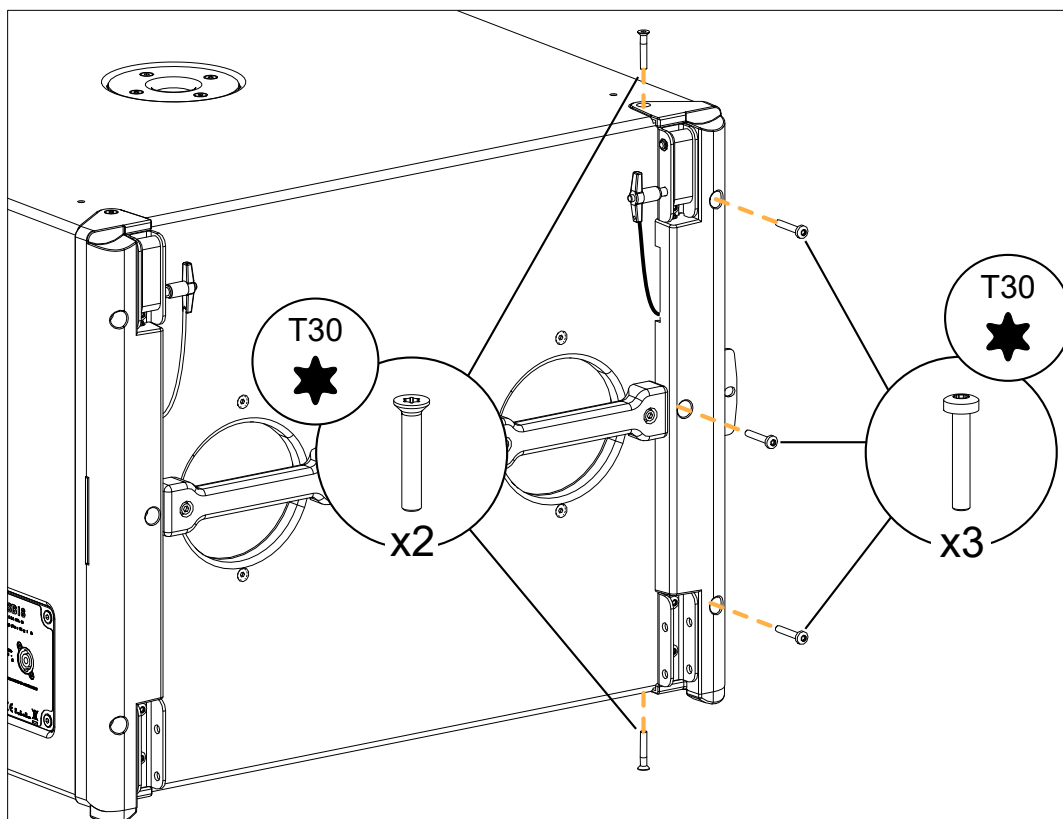

2. Remove the screw securing the steel tab.

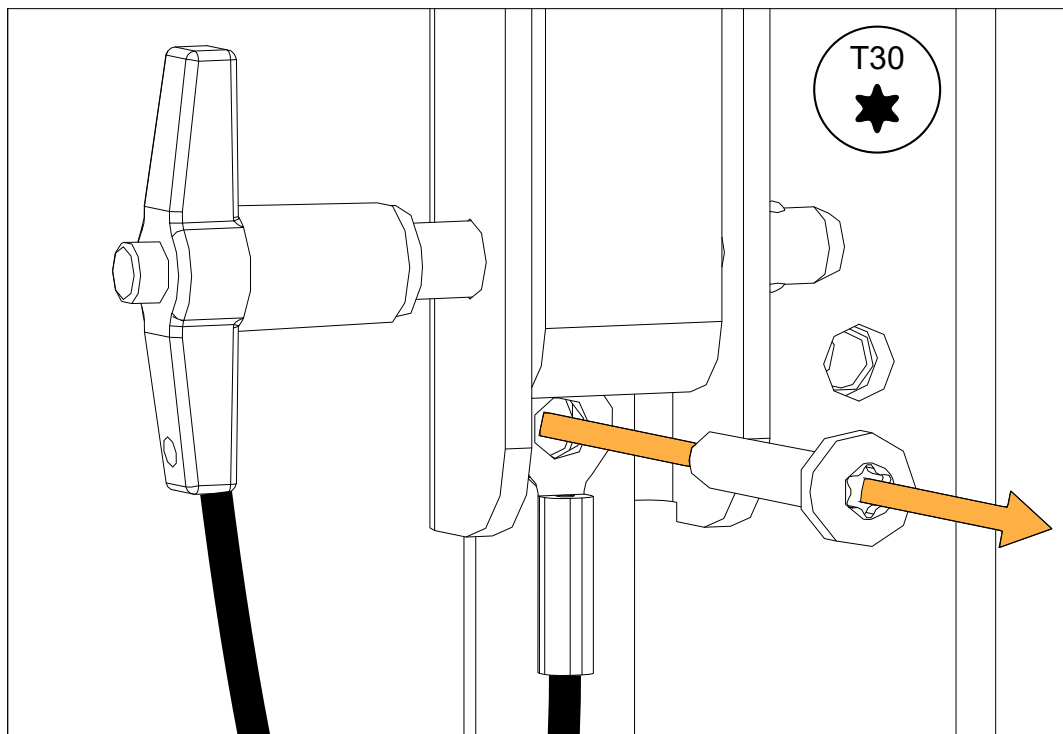

Reassembly

Procedure

1. Insert the pin in the storage hole.

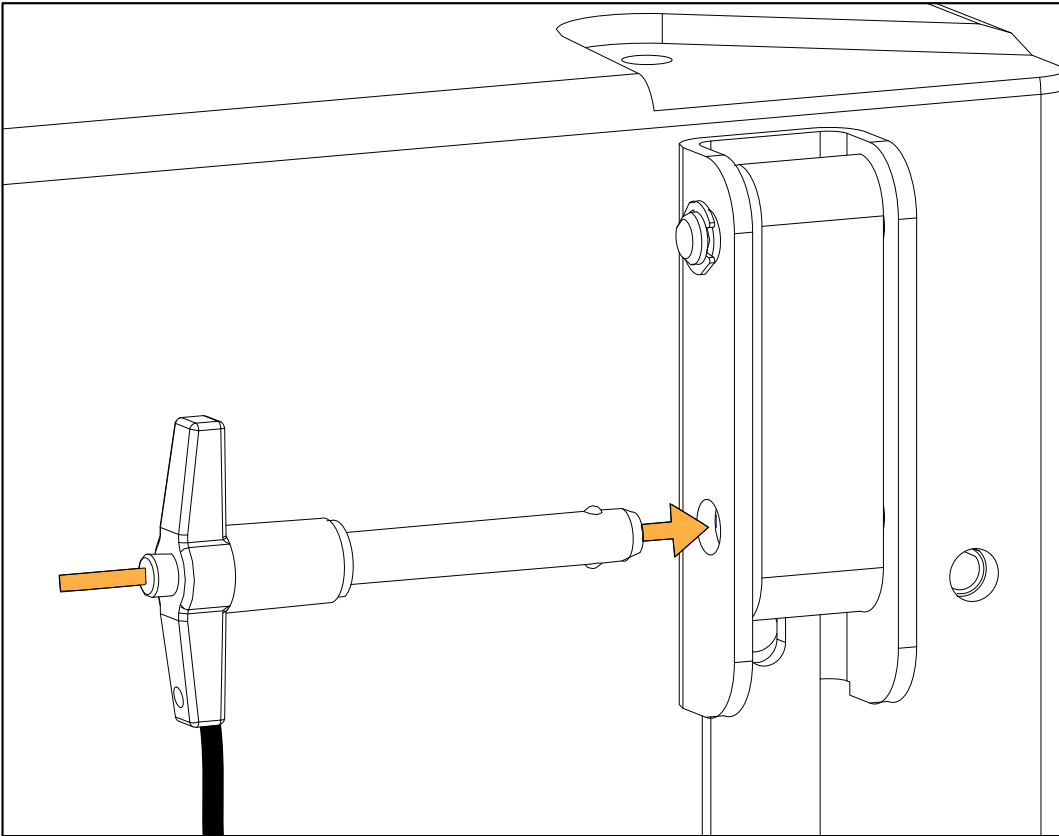

2. Position the steel tab on the screw.



Position the flat side of the steel tab toward the cabinet.

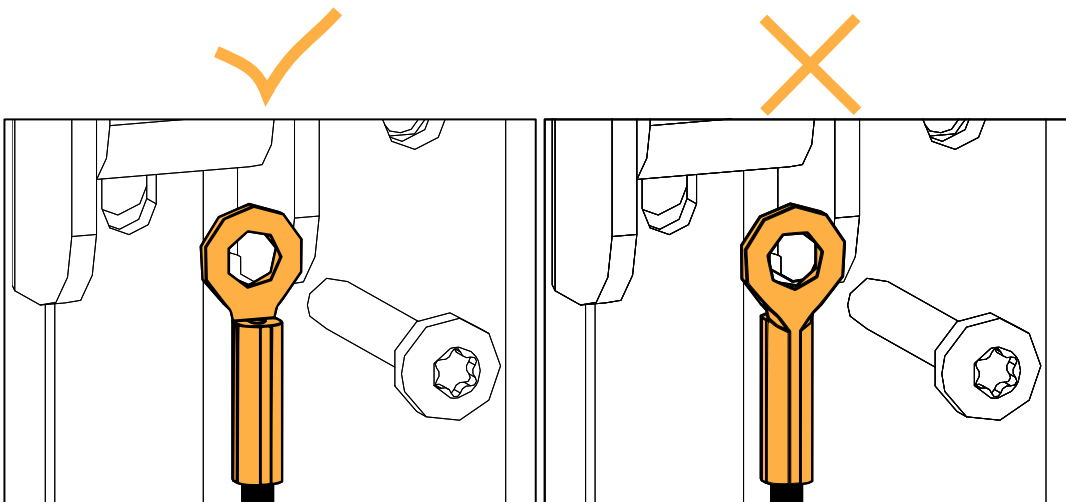

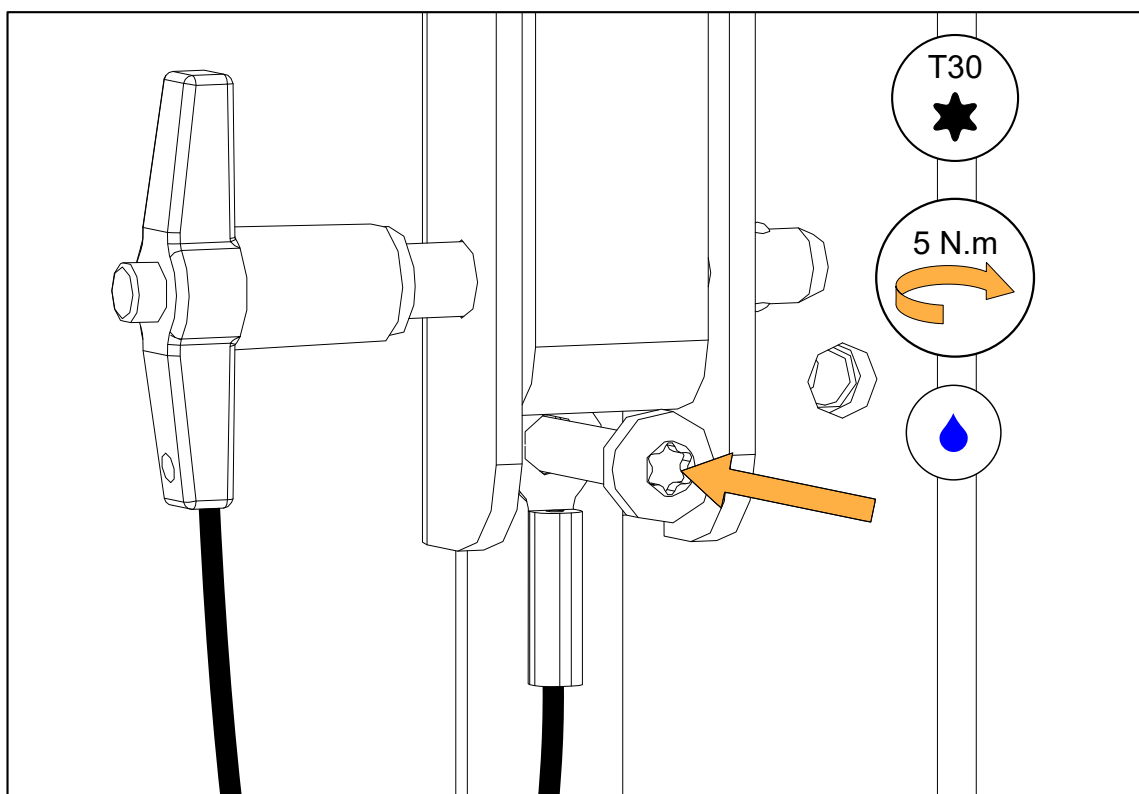
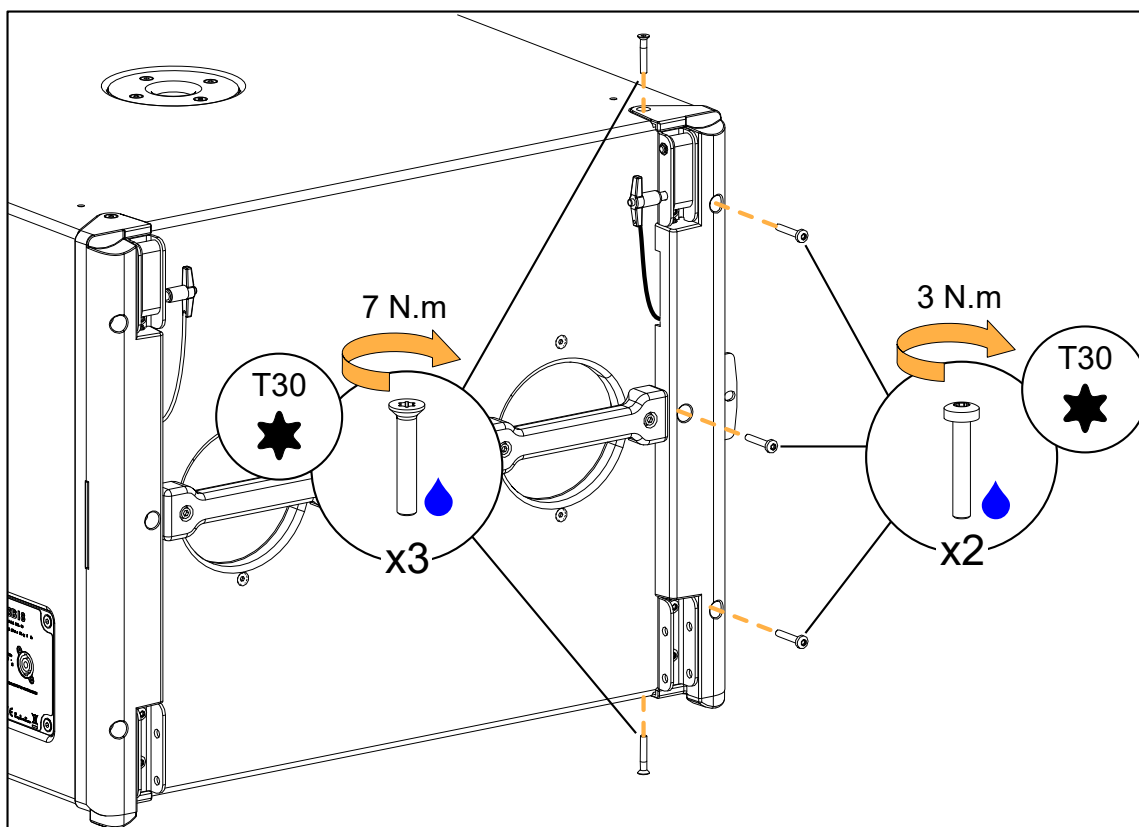
3. Secure the steel tab to the cabinet.**4.** Secure the protective cover with the five screws.

M-BUMP

Exploded view

In order to operate, follow the order outlined here. Each assembly refers to the corresponding Disassembly/Reassembly (D/R) procedure and the necessary repair kit.

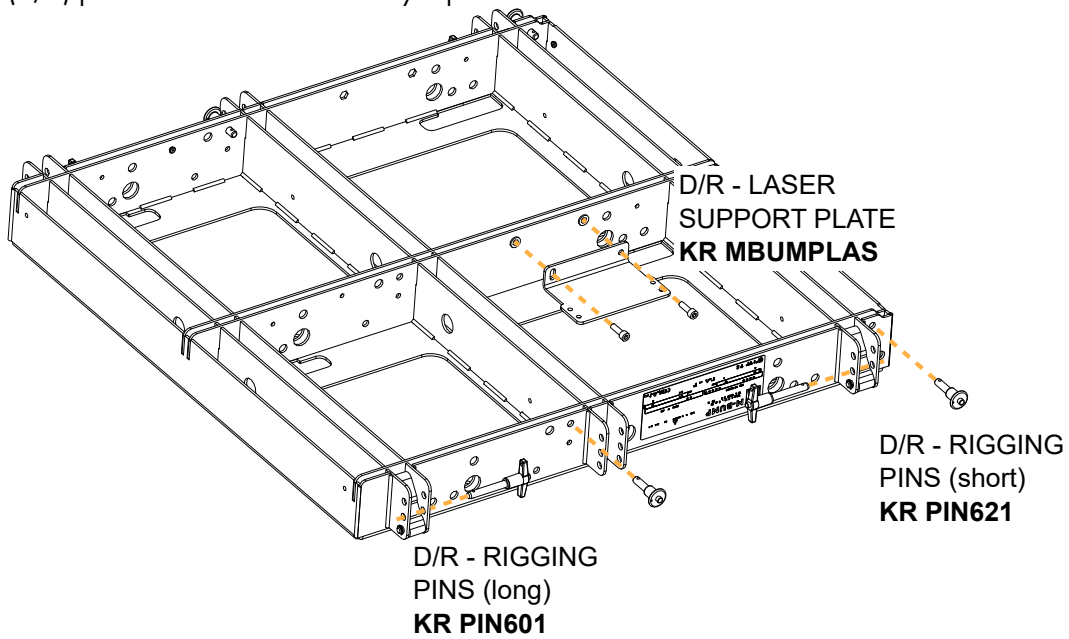

Disassembly and Reassembly procedures

D/R - Rigging pins (long)

Tools

- riveting pliers

Repair kit

! For safety reasons, always use the new screws and spare parts provided in the KR.
If no new screws are available, use blue threadlocker.

KR PIN601

Kit 10 pins long T-shaped head screws & rivets

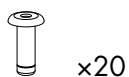

x20

S142

M4x10 rivet

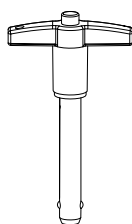

x10

601

ball-locking pin Ø5/16" with lanyard

Exploded view

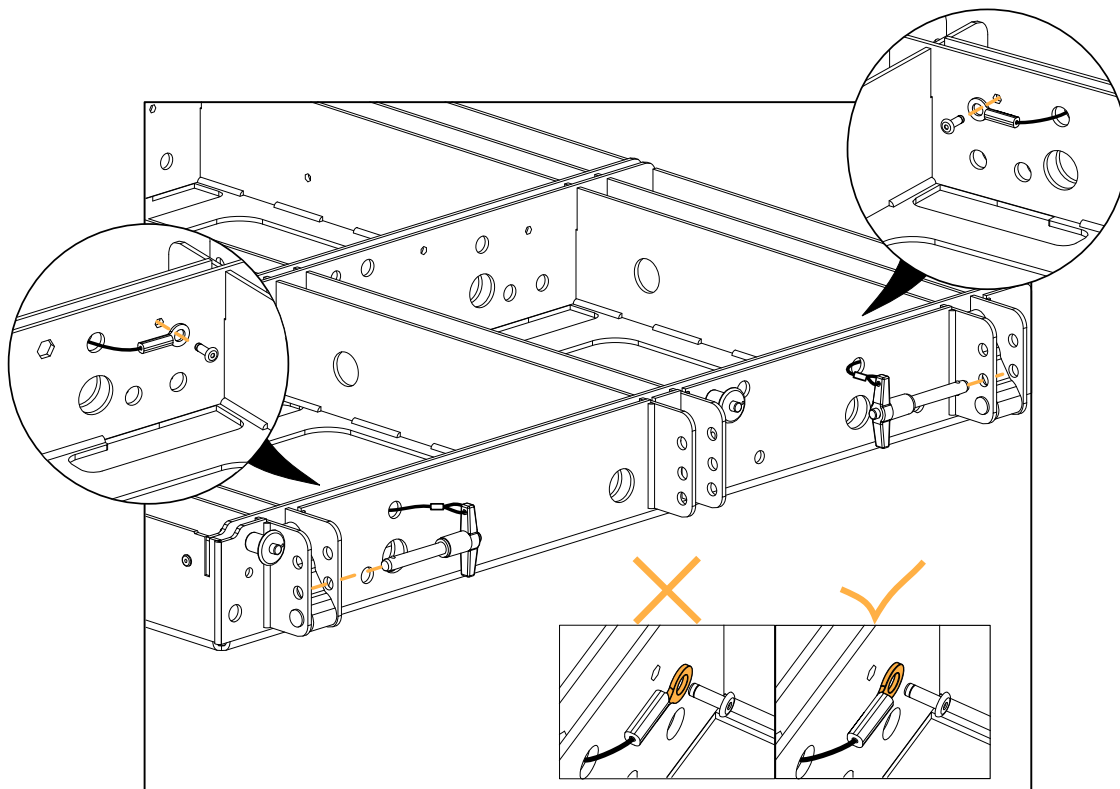

D/R - Rigging pins (short)

Tools

- riveting pliers

Repair kit



For safety reasons, always use the new screws and spare parts provided in the KR. If no new screws are available, use blue threadlocker.

KR PIN621

Kit 10 pins short round head screws & rivets

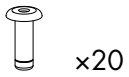

x20

S142

M4x10 rivet

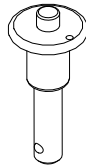

x10

621

ball-locking pin Ø5/16" with lanyard

Exploded view

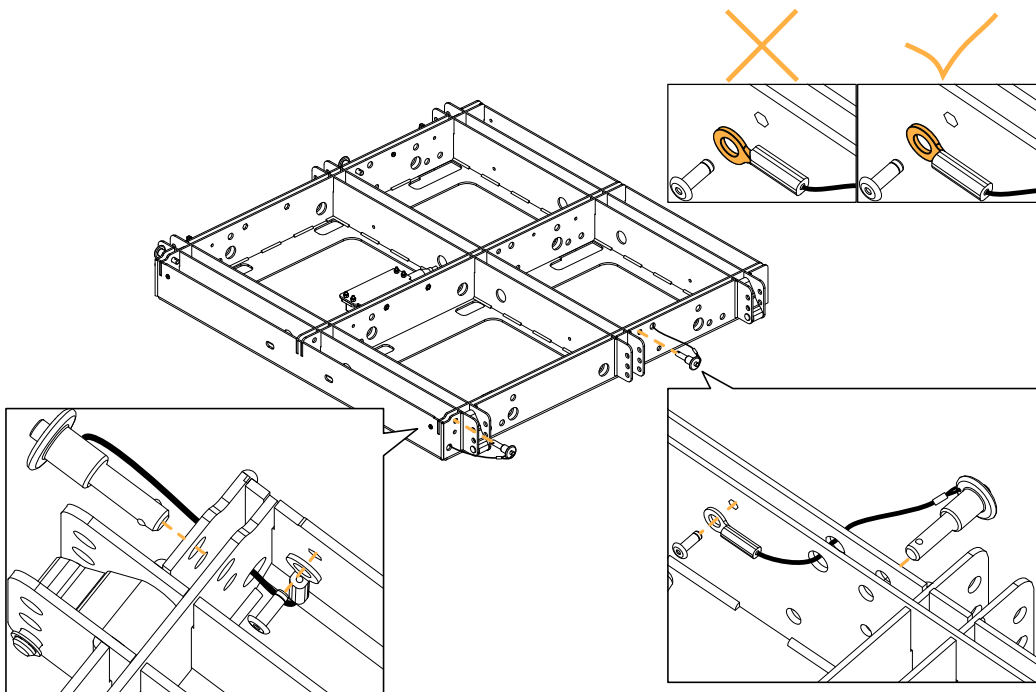

D/R - Laser support plate

Tools

- torque screwdriver
- T20 Torx bit
- 5 mm hex bit

Repair kits

KR MBUMPLAS

Kit laser mount for MBUMP

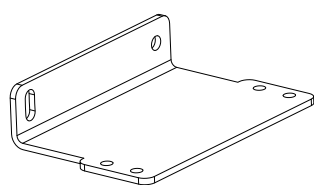

x1

550

laser support plate



x4

S210

M4x16 Torx



x4

S121

M4 hex lock nut

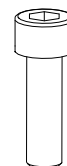

x2

S100105

M6x20 hex



For safety reasons, always use the new screws and spare parts provided in the KR.

Exploded view



Refer to [APPENDIX A](#) (p.192) for inclinometer / laser device mounting procedure.

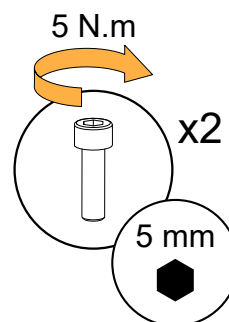
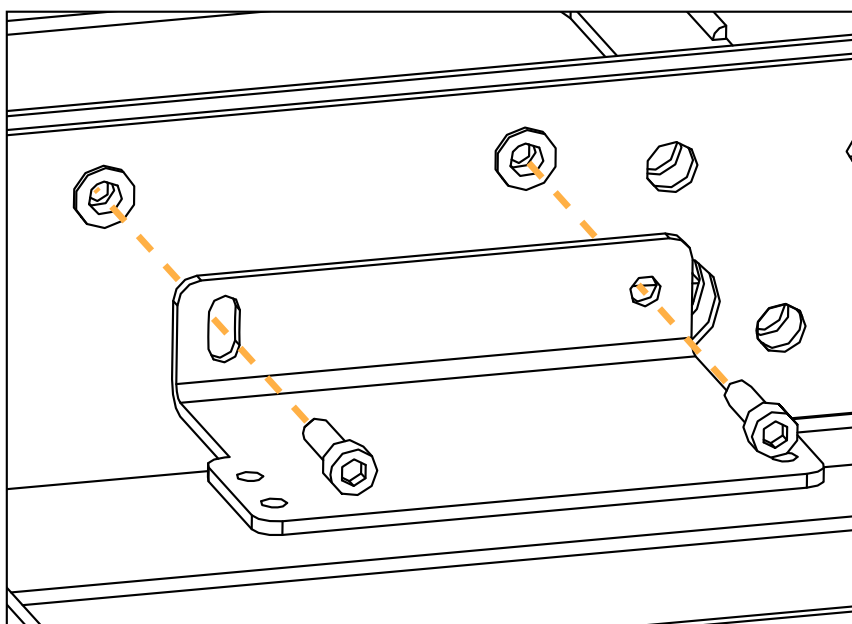

M-BAR

Exploded view

In order to operate, follow the order outlined here. Each assembly refers to the corresponding Disassembly/Reassembly (D/R) procedure and the necessary repair kit.

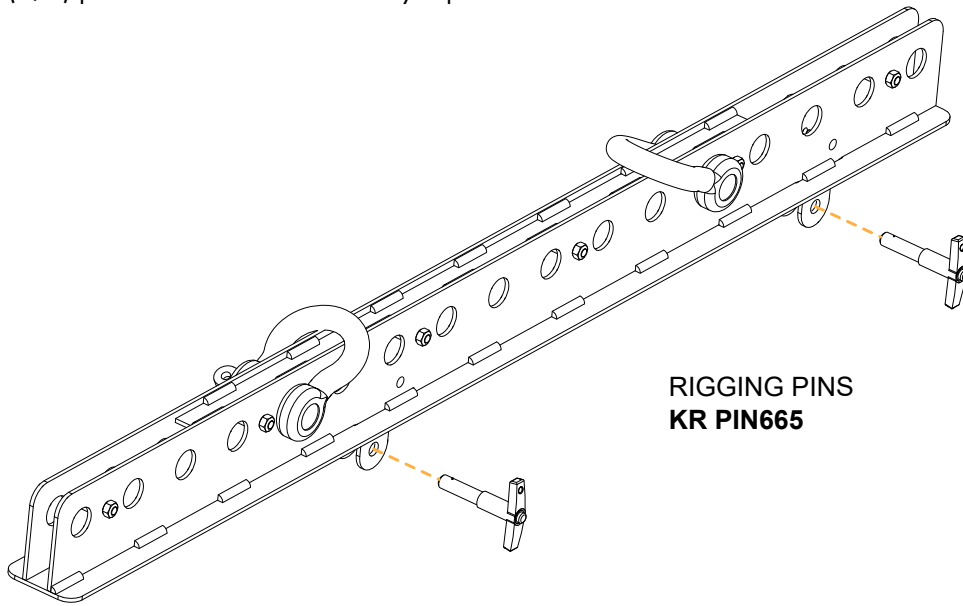

Disassembly and Reassembly procedures

D/R - Rigging pins

Tools

- riveting pliers

Repair kit

KR PIN665

Kit 10 pins 9.5mm diameter screws & rivets

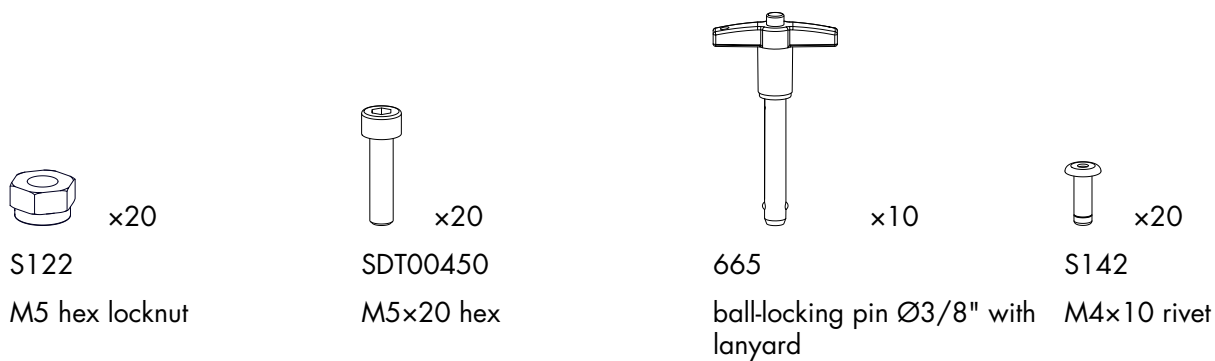

The S122 and SDT00450 are not used in this procedure.

Exploded view



For safety reasons, always use the new screws and spare parts provided in the KR.

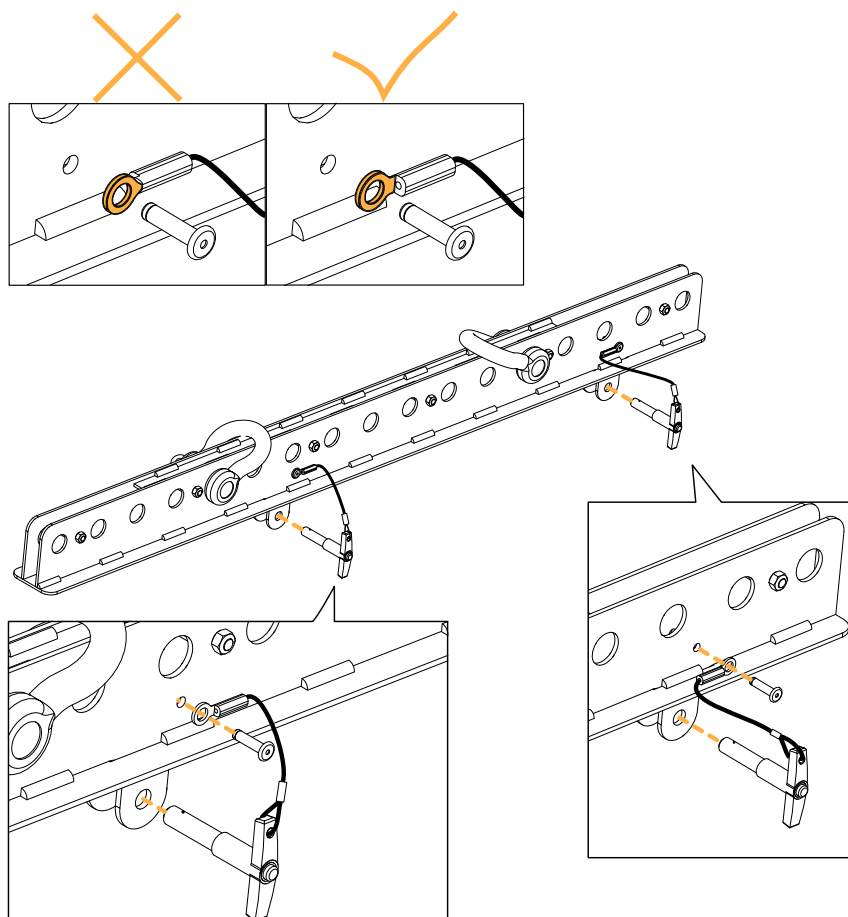

KARA-MINIBU

Exploded view

In order to operate, follow the order outlined here. Each assembly refers to the corresponding Disassembly/Reassembly (D/R) procedure and the necessary repair kit.

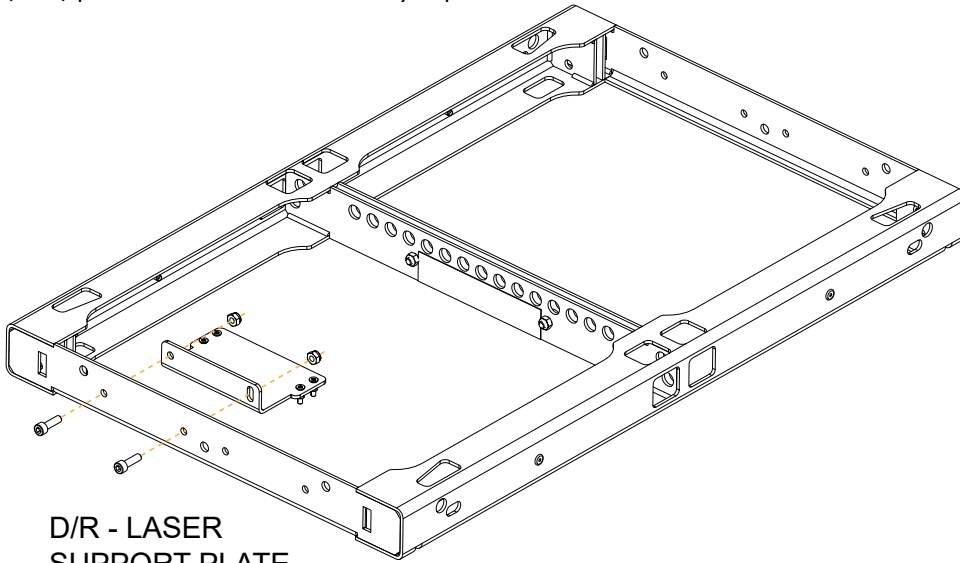

D/R - LASER
SUPPORT PLATE
KR MBUMPLAS

Disassembly and Reassembly procedures

D/R - Laser support plate

Tools

- torque screwdriver
- T20 Torx bit
- 5 mm hex bit

Repair kits

KR MBUMPLAS

Kit laser mount for MBUMP



For safety reasons, always use the new screws and spare parts provided in the KR.

Exploded view



Refer to [APPENDIX A](#) (p.192) for inclinometer / laser device mounting procedure.

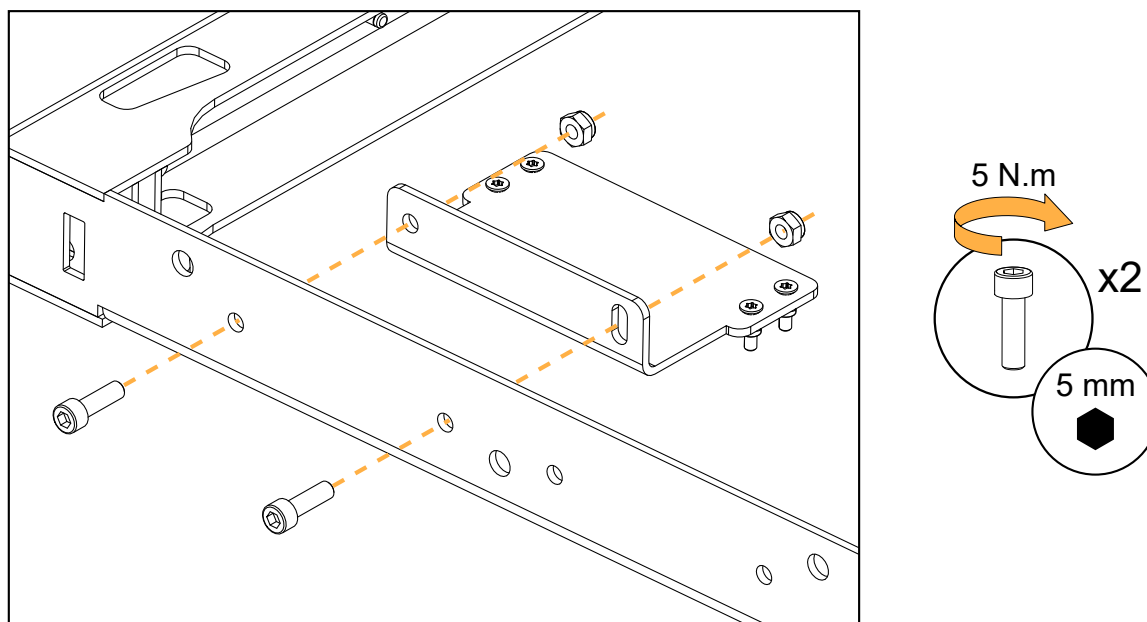

KARA-MINIBUEX

Exploded view

In order to operate, follow the order outlined here. Each assembly refers to the corresponding Disassembly/Reassembly (D/R) procedure and the necessary repair kit.

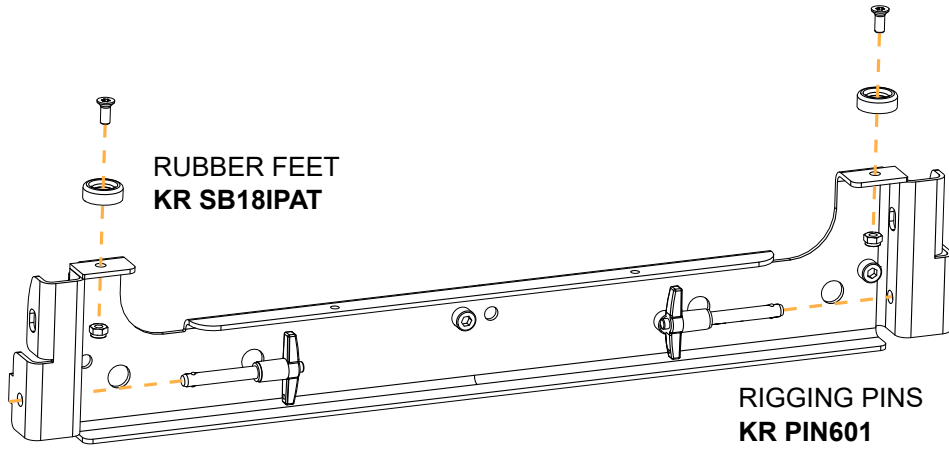

Disassembly and Reassembly procedures

D/R - Rigging pins

Tools

- riveting pliers

Repair kits

KR PIN601

Kit 10 pins long T-shaped head screws & rivets

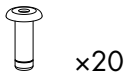

x20

S142

M4x10 rivet

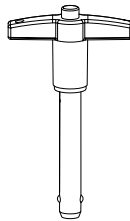

x10

601

ball-locking pin Ø5/16" with lanyard

Exploded view



For safety reasons, always use the new screws and spare parts provided in the KR.

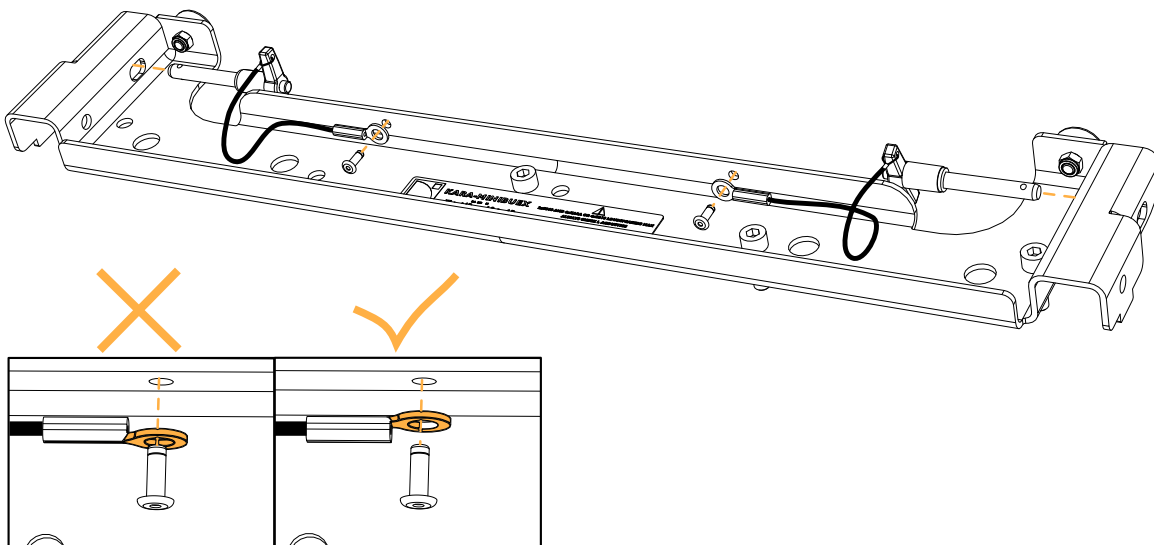

D/R - Rubber feet

Tools

- torque screwdriver
- T30 Torx bit

Repair kit

KR SB18IPAT

Kit SB18i 4 pads

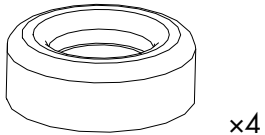

609

runner Ø25 mm



Save the screws and fasteners for reassembly.

Exploded view

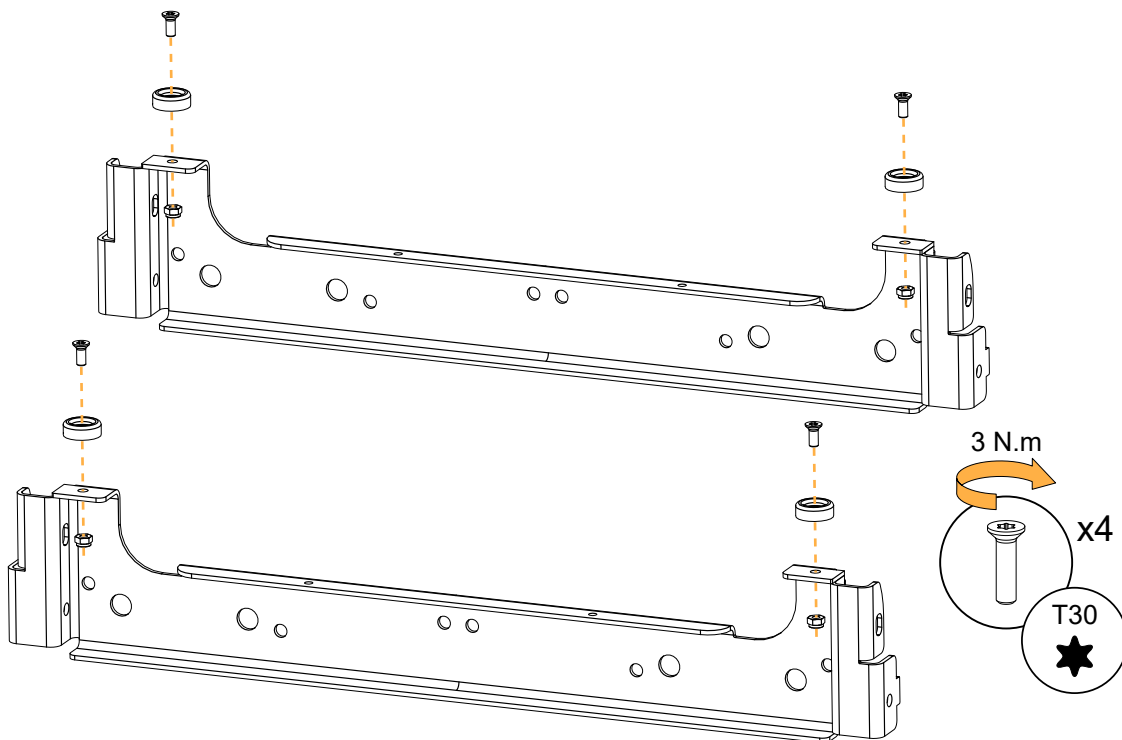

Specifications

Kara II specifications

Description	2-way active WST® enclosure: 2 x 8" LF + 3" HF diaphragm, amplified by LA4X / LA8 / LA12X
Usable bandwidth (-10 dB)	55 Hz - 20 kHz ([KARA II 70])
Maximum SPL ¹	142 dB ([KARA II 70])
Nominal directivity (-6 dB)	horizontal: 70° / 110° symmetric or 90° asymmetric (35°/90°) vertical: dependent upon the number of elements and the line source curvature
Transducers	LF: 2 x 8" neodymium cone drivers HF: 1 x 3" neodymium diaphragm compression driver
Acoustical load	LF: bass-reflex HF: DOSC waveguide, L-Fins
Nominal impedance	LF: 8 Ω HF: 8 Ω
Connectors	IN: 1 x 4-point speakON LINK: 1 x 4-point speakON
Rigging and handling	4-point captive rigging system 2 side handles 2 rear handles inter-enclosure angles: 0°, 1°, 2°, 3°, 4°, 5°, 7.5° or 10°
Weight (net)	26 kg / 57 lb
Cabinet	premium grade Baltic birch plywood
Front	coated steel grill acoustically neutral 3D fabric
Rigging components	high grade steel with anti-corrosion coating
Finish	dark grey brown Pantone 426 C
IP	IP55

¹ Peak level measured at 1 m under free field conditions using pink noise with crest factor 4 (preset specified in brackets).

Kara II dimensions

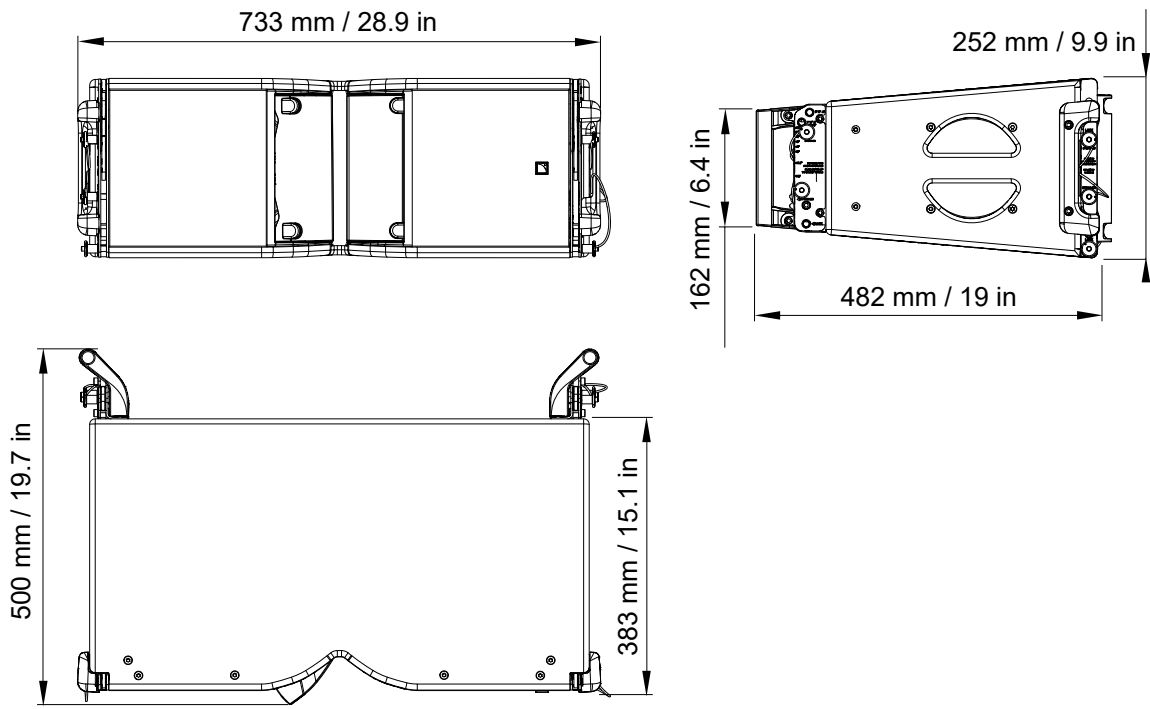

SB18 specifications

Description	High power compact subwoofer: 1 x 18" , amplified by LA4X / LA8 / LA12X
Low frequency limit (-10 dB)	32 Hz ([SB18_100])
Maximum SPL¹	138 dB ([SB18_100])
Nominal directivity (-6 dB)	standard or cardioid
Transducers	1 x 18"
Acoustical load	dual bass-reflex, L-Vents
Nominal impedance	8 Ω
Connectors	IN: 1 x 4-point speakON LINK: 1 x 4-point speakON
Rigging and handling	4 handles integrated into the cabinet captive rigging system 1 x 35 mm pole socket
Weight (net)	52 kg / 115 lb
Cabinet	premium grade Baltic birch plywood
Front	coated steel grill acoustically neutral 3D fabric
Rigging components	steel with anti-corrosion coating
Finish	dark grey brown Pantone 426 C
IP	IP55

¹ Peak level at 1 m under half space conditions using pink noise with crest factor 4 (preset specified in brackets).

SB18 dimensions

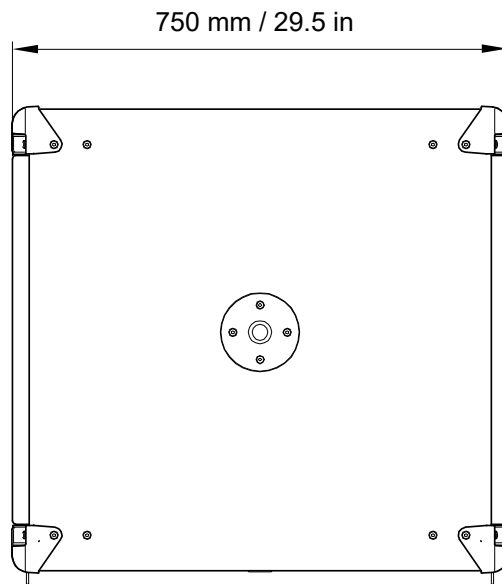
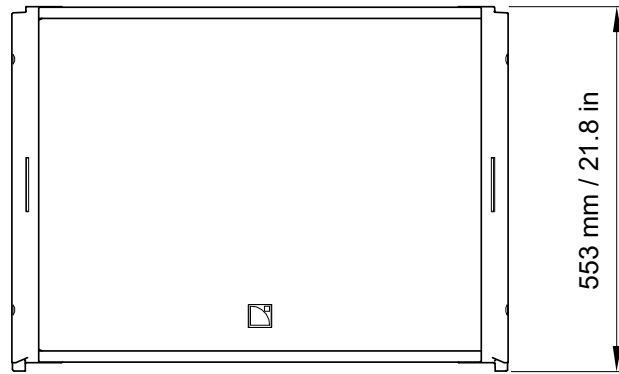
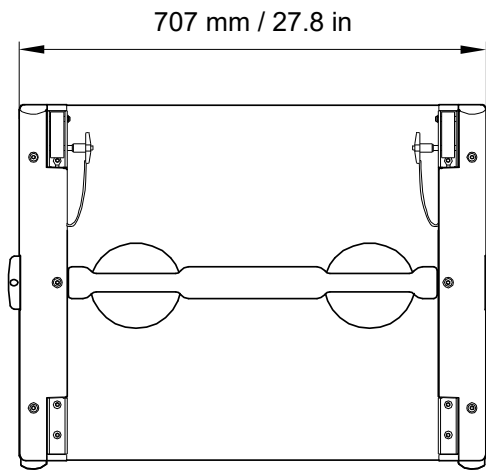

KS21 specifications

Description	High power compact subwoofer: 1x21" , amplified by LA4X / LA8 / LA12X
Low frequency limit (-10 dB)	31 Hz ([KS21_100])
Maximum SPL¹	138 dB ([KS21_100])
Nominal directivity (-6 dB)	standard or cardioid configuration
Transducers	1 × 21" neodymium cone driver
Acoustical load	bass-reflex, L-Vents
Nominal impedance	8 Ω
Connectors	IN: 1 × 4-point speakON LINK: 1 × 4-point speakON
Rigging and handling	flush-fitting 2-point rigging system 4 handles 8 corner stops 2 ground runners 1 pole mount with M20×150 insert
Weight (net)	49 kg / 108 lb
Cabinet	premium grade Baltic beech and birch plywood
Front	coated steel grill acoustically neutral 3D fabric
Rigging components	high grade steel with anti-corrosion coating
Finish	dark grey brown Pantone 426 C
IP	IP55

¹ Peak level at 1 m under half space conditions using pink noise with crest factor 4 (preset specified in brackets).

KS21 dimensions

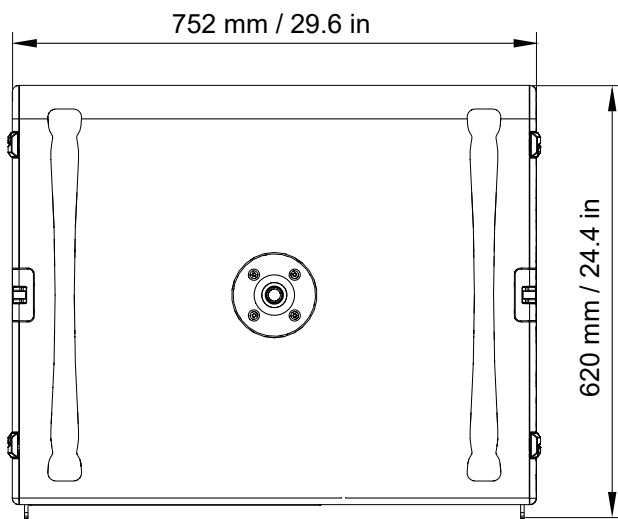
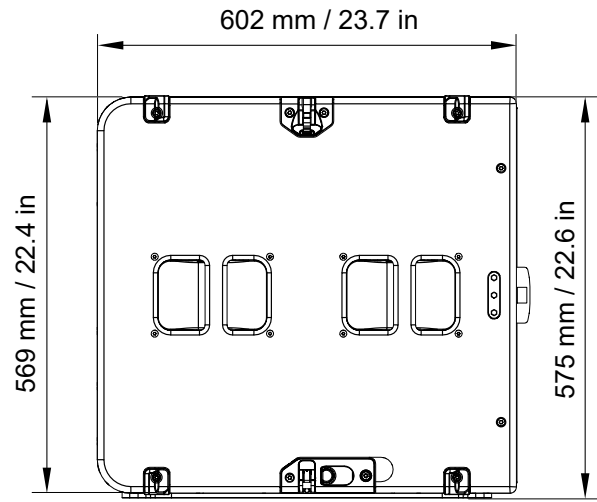
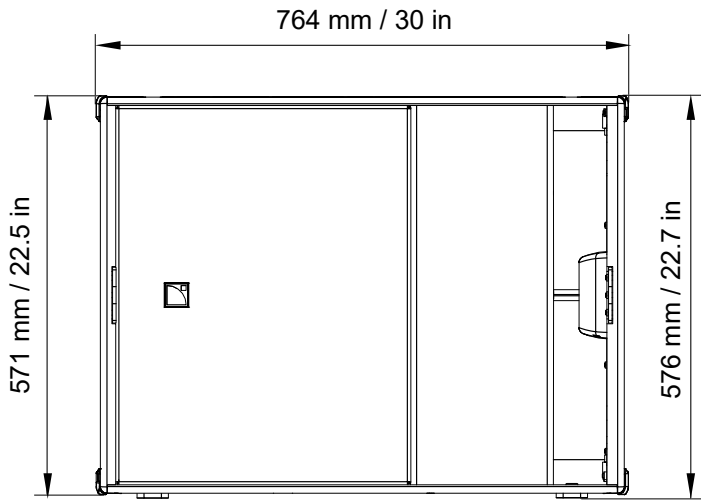

SB28 specifications

Description	High power subwoofer: 2 x 18" , amplified by LA8 / LA12X
Low frequency limit (-10 dB)	25 Hz ([SB28_100])
Maximum SPL¹	142 dB ([SB28_100])
Directivity	standard or cardioid
Transducers	2 x 18" neodymium direct-radiating
Acoustical load	bass-reflex, L-Vents
Nominal impedance	4 Ω
Connectors	IN: 1 x 4-point speakON
Rigging and handling	integrated rigging system handles integrated into the cabinet
Weight (net)	93 kg / 205 lb
Cabinet	premium grade Baltic birch plywood
Front	coated steel grill acoustically neutral 3D fabric
Rigging components	high grade steel with anti-corrosion coating
Finish	dark grey brown Pantone 426 C
IP	55

¹ Peak level at 1 m under half space conditions using pink noise with crest factor 4 (preset specified in brackets).

SB28 dimensions

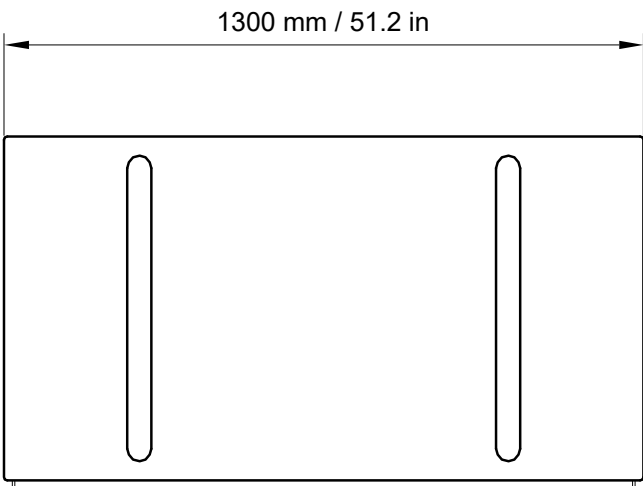
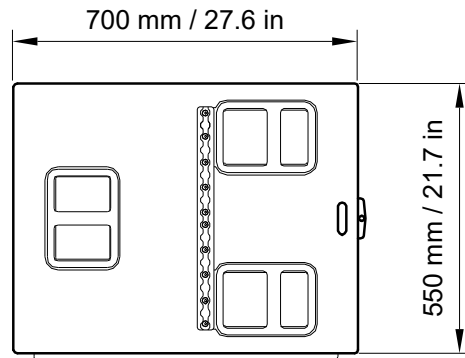
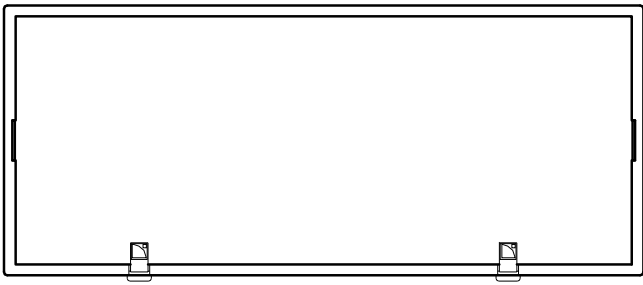

KS28 specifications

Description	Flyable subwoofer 2 x 18" , amplified by LA12X
Low frequency limit (-10 dB)	25 Hz ([KS28_100])
Maximum SPL¹	143 dB ([KS28_100])
Directivity	standard or cardioid
Transducers	2 x 18" neodymium cone drivers
Acoustical load	bass-reflex, L-Vents
Nominal impedance	4 Ω
Connectors	IN: 1 x 4-point speakON
Rigging and handling	flush-fitting 2-point rigging system 6 ergonomic handles 2 ground runners 8 side runners
Weight (net)	79 kg / 174 lb
Cabinet	premium grade Baltic beech and birch plywood
Front	coated steel grill acoustically neutral 3D fabric
Rigging components	high grade steel
Finish	dark grey brown Pantone 426 C

¹ Peak level at 1 m under half space conditions using pink noise with crest factor 4 (preset specified in brackets).

KS28 dimensions

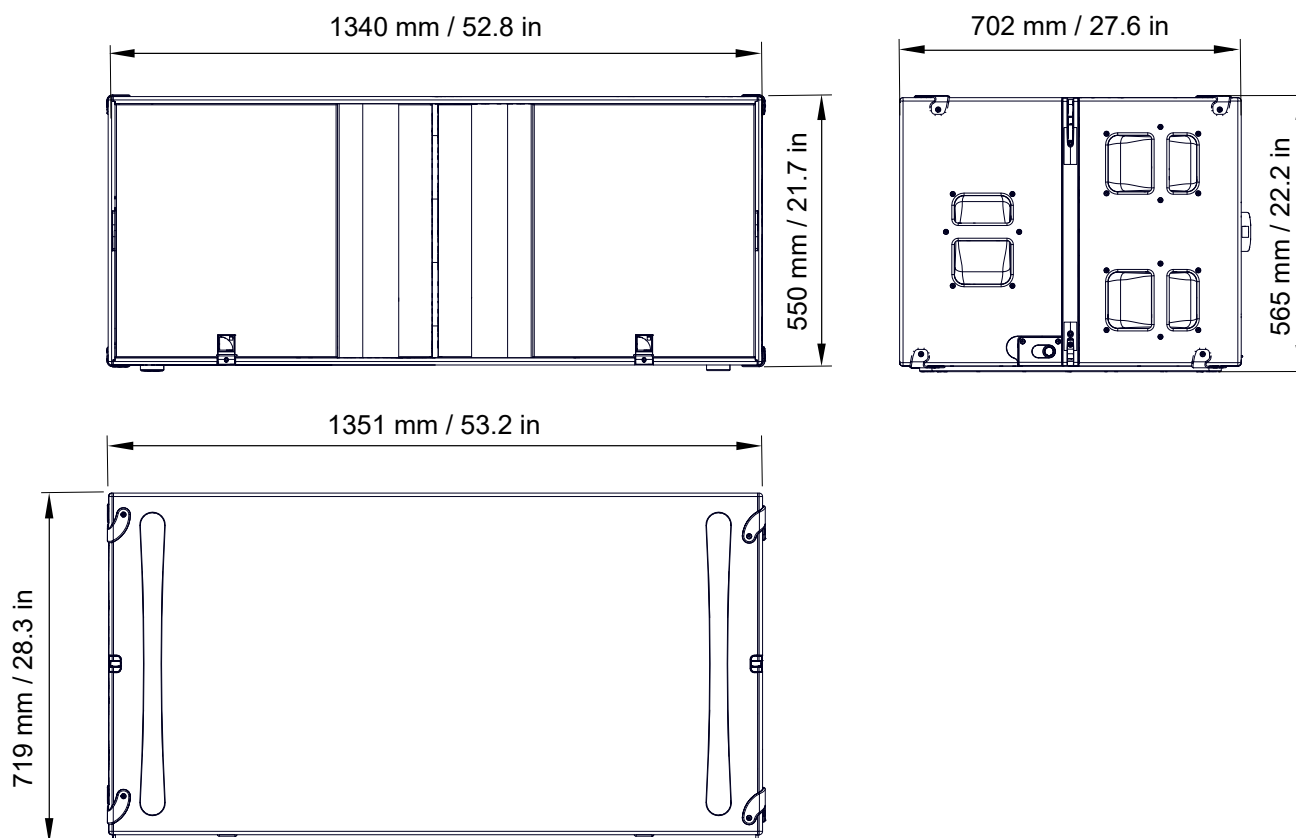

M-BUMP specifications

Description	Bumper for flying or stacking KARA/SB18 2 x Ø19 mm shackles WLL 3.25 t
Weight (net)	25 kg / 55 lb
Material	high grade steel with anti-corrosion coating

M-BUMP dimensions

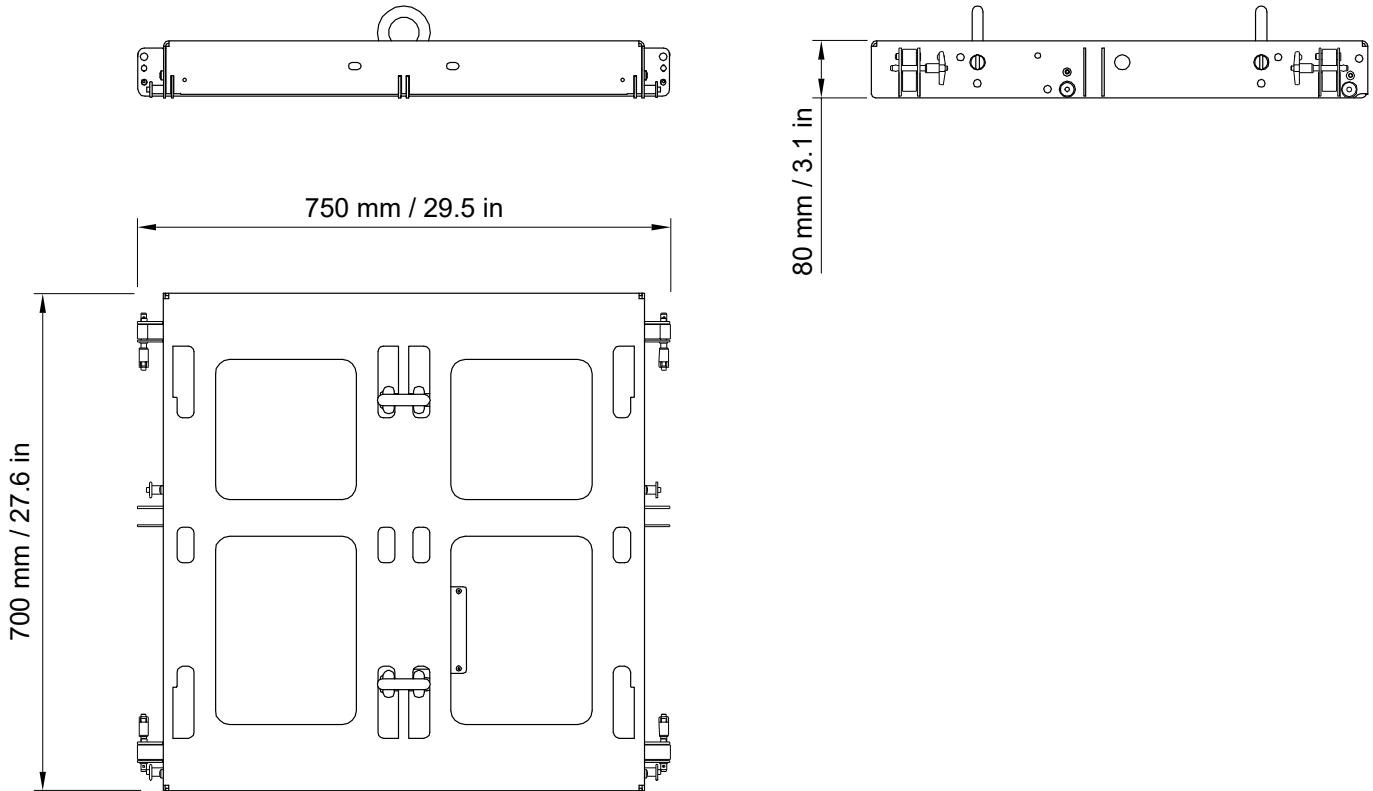

M-BAR specifications

Description	Extension bar for rigging frame 2 x Ø19 mm shackles WLL 3.25 t
Weight (net)	5 kg / 11 lb
Material	high grade steel with anti-corrosion coating

M-BAR dimensions

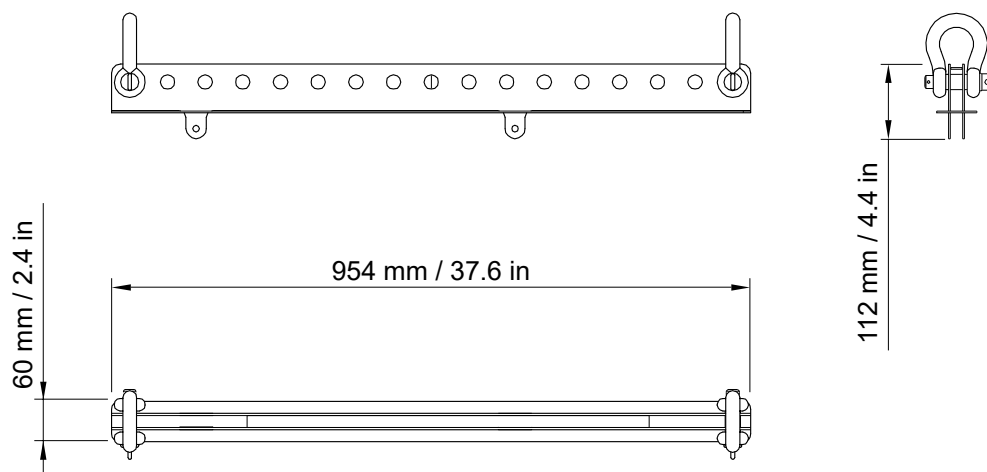

M-JACK specifications

Description	4 tilt adjustment screw jacks with 2 angle bar extensions for stacked M-BUMP 4 axis with safety pin
Weight (net)	1.3 kg / 2.9 lb
Material	high grade steel with anti-corrosion coating

M-JACK dimensions

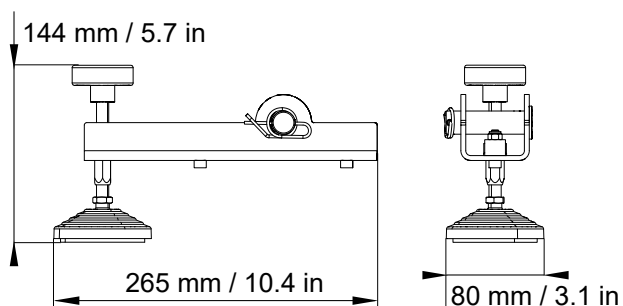

KARA-ANGARMEX specifications

Description	2 angle bar extension for KARA bumper 2 x Ø4.8 x 18mm rivets 2 M4 x 12mm Allen bolts
Weight (net)	0.6 kg / 1.3 lb
Material	high grade steel with anti-corrosion coating

KARA-ANGARMEX dimensions

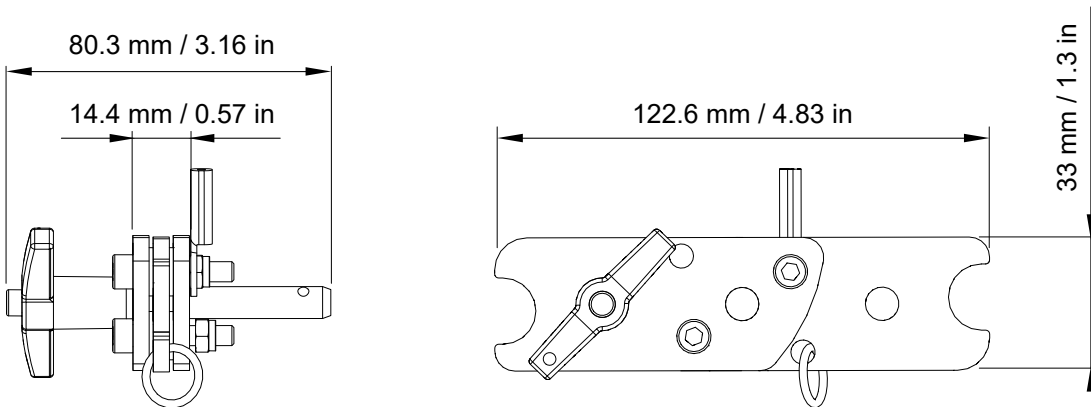

KARA-MINIBU specifications

Description	Mini bumper for flying 6 KARA 2 x Ø12 mm shackles WLL 1 t
Weight (net)	7.6 kg / 17 lb
Material	high grade steel with anti-corrosion coating

KARA-MINIBU dimensions

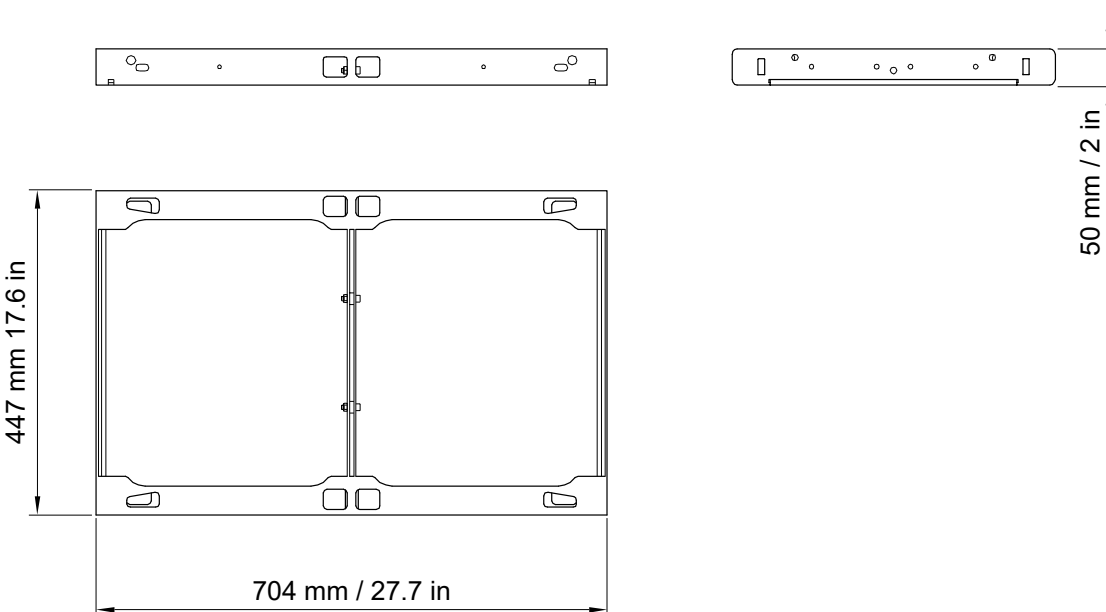

KARA-MINIBUEX specifications

Description	Extension bars for flying/stacking SB18/KARA 6 M8x25 screws 6 M8 lock nuts
Weight (net)	2.2 kg / 5 lb
Material	high grade steel with anti-corrosion coating

KARA-MINIBUEX dimensions

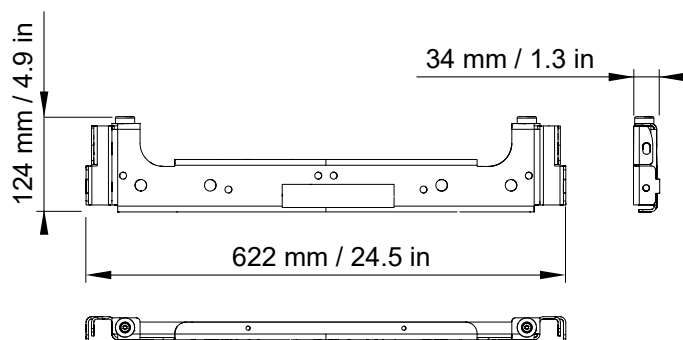

KARA-PULLBACK specifications

Description	pullback plate for Kara 1 x Ø19 mm shackle WLL 3.25 t
Weight (net)	6 kg / 13 lb
Material	high grade steel with anti-corrosion coating

KARA-PULLBACK dimensions

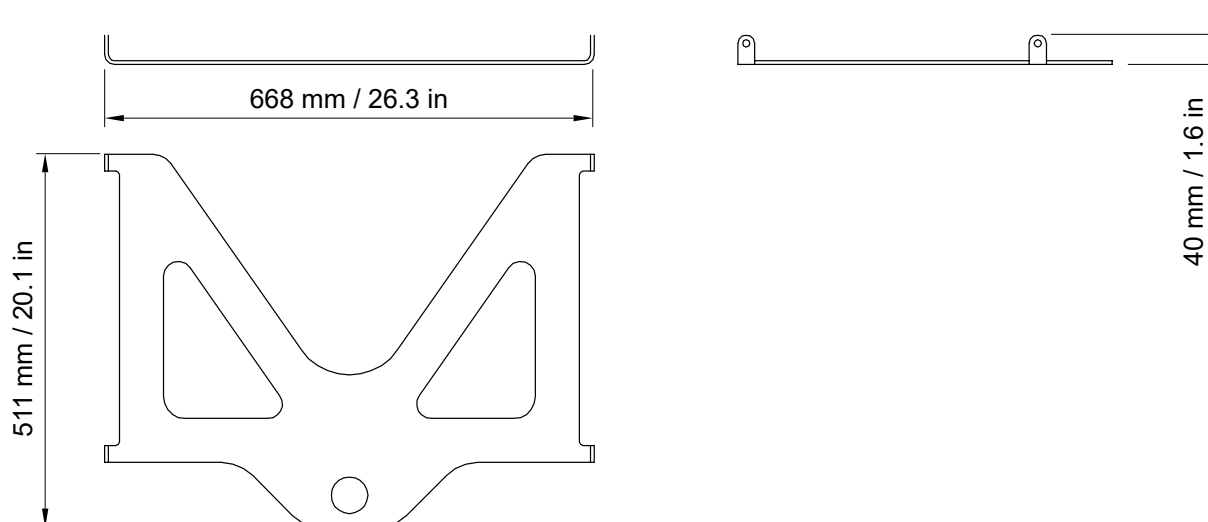

Inclinometer mounting

About this task

A laser support plate has been integrated inside the M-BUMP and the KARA-MINIBU for optional inclinometer/laser device mounting. Three models are compatible: TEQSAS LAP-TEQ PLUS (part of the L-Acoustics **TECH TOOLCASE** - refer to the **TECH TOOLCASE** Product spec sheet), TEQSAS LAP-TEQ (legacy model) and KSG RECLINE Compact.



LAP-TEQ / LAP-TEQ PLUS sensor and display compatibility

The legacy LAP-TEQ sensors are compatible with the new TEQSAS® LAP-TEQ PLUS displays.

Conversely, the new sensors are **not** compatible with the legacy displays.

M-BUMP laser support plate and LAP-TEQ inclinometer mounted to it

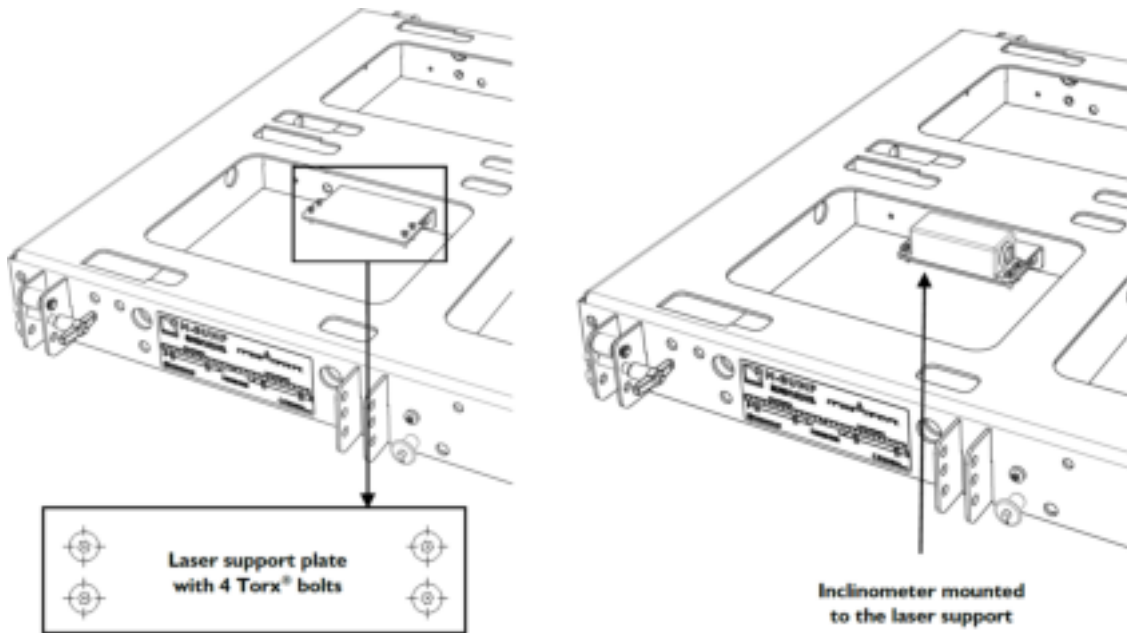

KARA-MINIBU laser support plate and LAP-TEQ inclinometer mounted to it

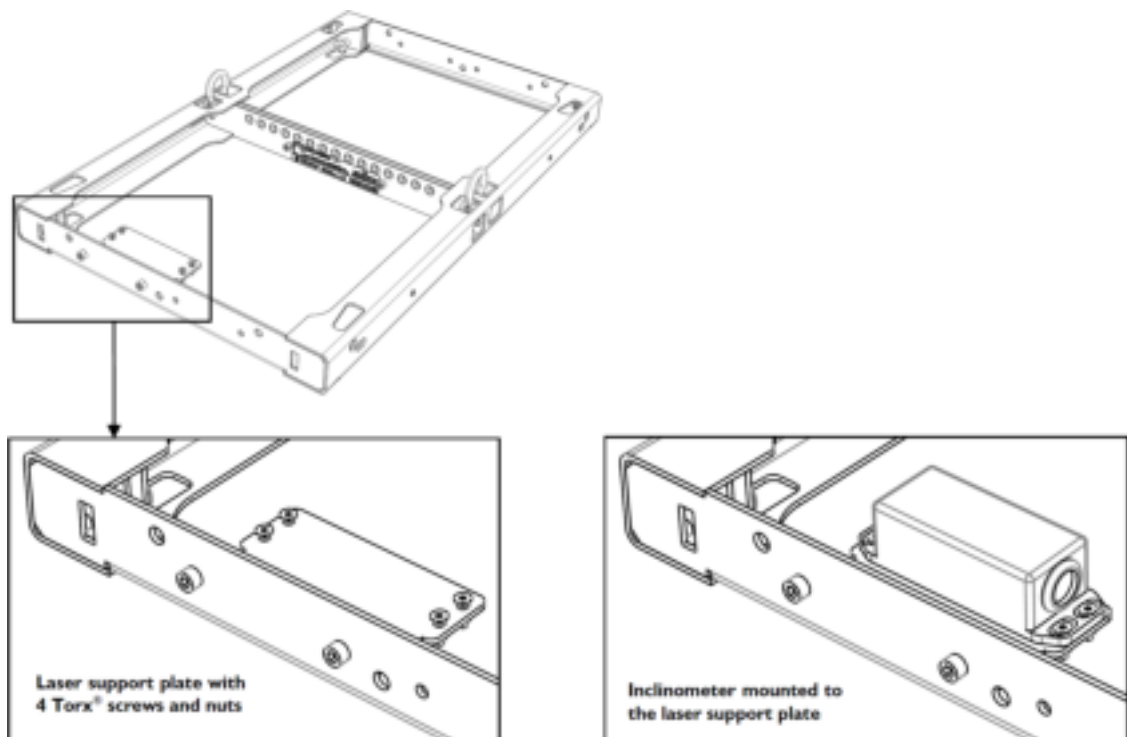

Sensor mounting procedure

Required tools

- handheld inclinometer (available in the **TECH TOOLCASE**)
- electric screwdriver with torque selector
- T20 Torx bit
- 7 mm hex key
- XLR cable

Procedure

- 1.** Place the M-BUMP / KARA-MINIBU on a flat horizontal surface (use the handheld inclinometer).
- 2.** Unscrew the four Torx bolts from the laser support plate (T20 bit, 7 mm hex key).
- 3.** Mount the sensor on the laser support plate with laser lens towards the M-BUMP / KARA-MINIBU slits.
- 4.** Screw the 4 Torx bolts to the sensor and plate (T20 bit, 7 mm hex key, 3 N.m / 27 in.lbf).
- 5.** Connect an XLR cable to the sensor.
- 6.** Calibrate the sensor by following the manufacturer's recommendations.

Flown array options and site angle setting

Using M-BUMP

M-BUMP rigging options

L-Acoustics recommends 5 different rigging options to fly the M-BUMP for arrays containing Kara II and/or SB18 enclosures. It is possible to use 0, 1, or 2 M-BAR and 1 or 2 rigging points (see figure below).

 Always refer to the mechanical data and warning indications provided in [Soundvision Software \(Mechanical Data section\)](#) to verify the mechanical conformity of the loudspeaker system before installation.



Option 1: 0 M-BAR, 1 point

1 motor
3 positions (front, center, rear)



Option 2: 0 M-BAR, 2 points

2 motors
Fixed front and rear positions
(spacing = 400 mm/15 inch)



Option 3: 1 M-BAR, 1 point

1 motor
Variable position (see [M-BUMP site angle setting \(p.195\)](#))
Left view = rear extension configuration
Right view = front extension configuration



Option 4: 1 M-BAR, 2 points

2 motors
Fixed front and rear positions
(spacing = 900 mm/35 inch)
Left view = rear extension configuration
Right view = front extension configuration

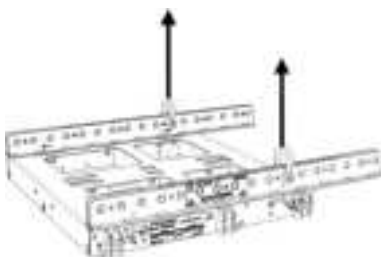

Option 5: 2 M-BAR, 2 points

2 motors
Variable position from front to rear
Same hole number for both points [8.2.2]
(spacing = 663 mm/26 inch)
Left view = rear extension configuration
Right view = front extension configuration

M-BUMP site angle setting

The M-BUMP site angle setting will be discrete or continuous depending on the chosen rigging option.

Rigging option 1 offers three discrete angle values.

Rigging options 3 and 5 offer 34 discrete angle values. First select the M-BAR position (A or B) and then the shackle position (holes 0-16) as shown in the figures below.

i For rigging options 1, 3, and 5 the M-BUMP site angle will also depend on the size and shape of the array (number of enclosures and inter-enclosure angles). Refer to [Soundvision Software](#) for site angle calculation.

Discrete angle selection (rear extension configuration)

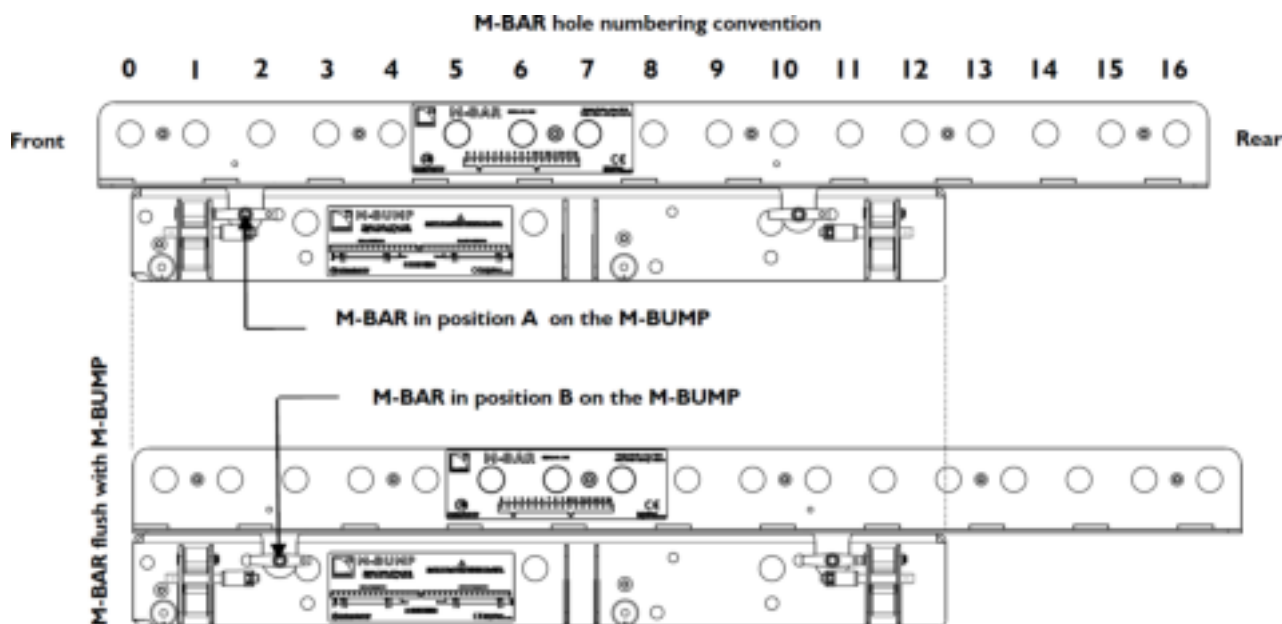

Discrete angle selection (front extension configuration)

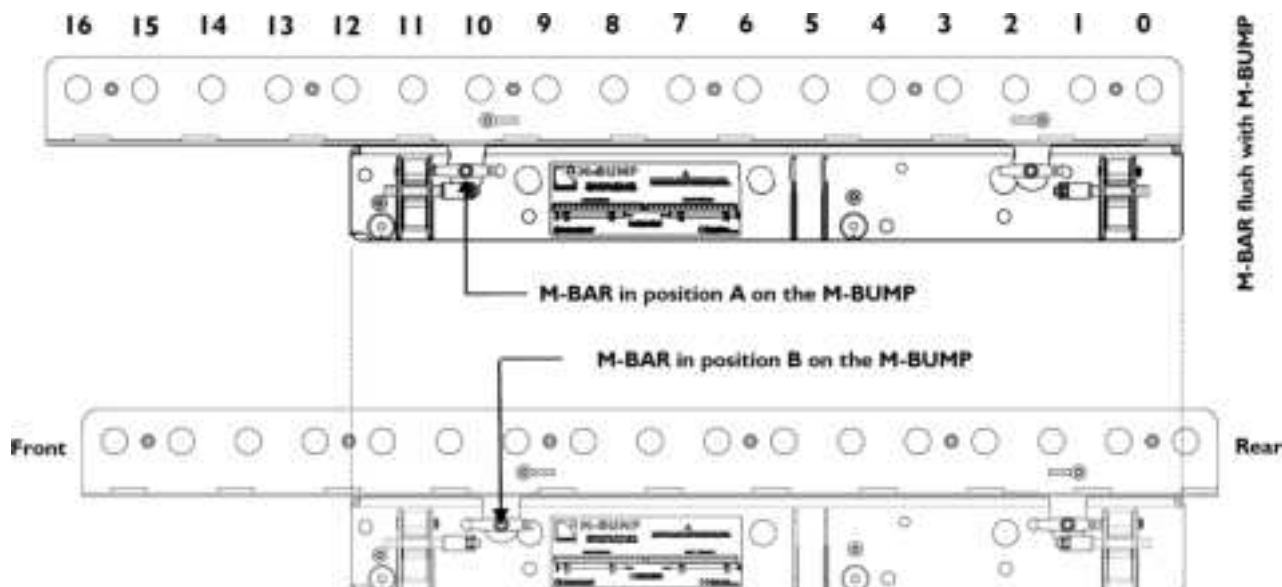

Rigging options 2 and 4 allow continuous M-BUMP site angle setting depending on the relative heights between the front and rear rigging points. Option 2 offers a small setting range. Option 4 enlarges the setting range for negative site angles in rear extension configuration and positive site angles in front extension configuration (see figure below).

i For option 4, it is recommended to position both shackles in holes 0 and 16.

Continuous angle selection (option 4 examples)

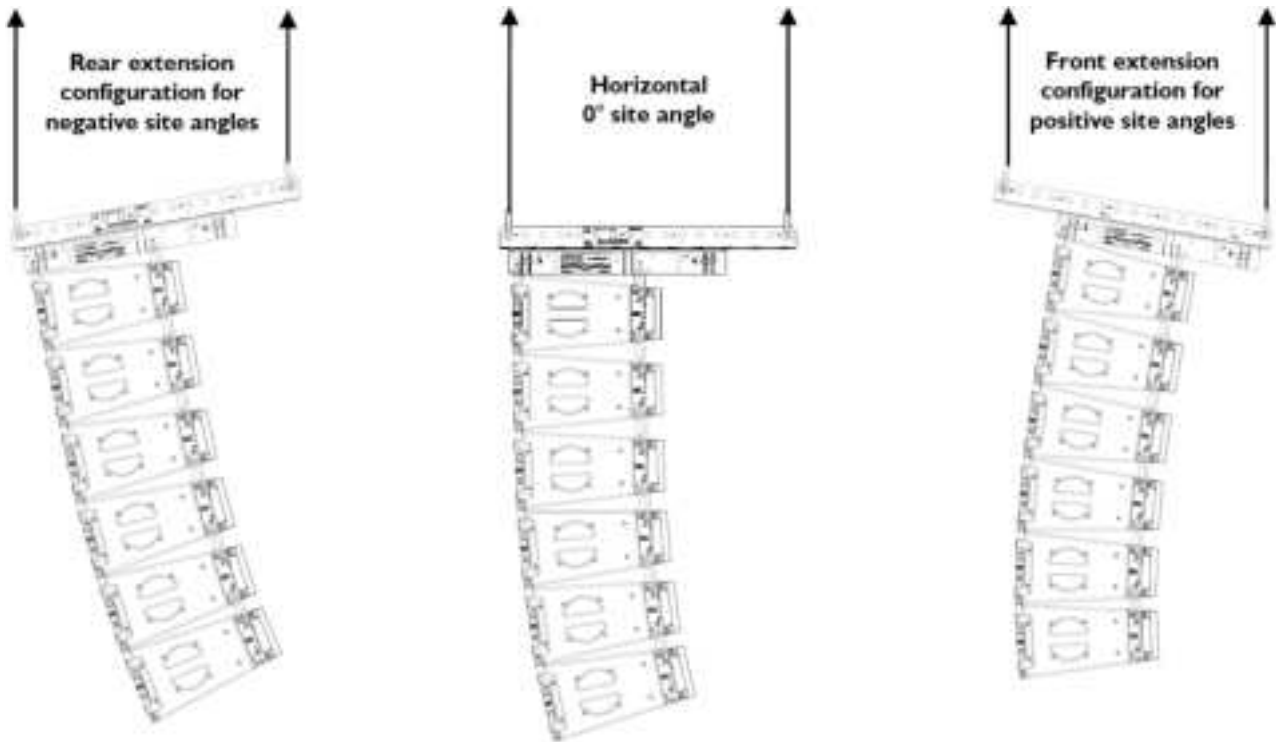

KARA-PULLBACK setup safety limits

The KARA-PULLBACK accessory mounts to the bottom enclosure of a Kara II array to allow setting the site angle down to -90° and obtain a pullback configuration. However, this limit depends on the composition of the array as shown in the table below.

 ALWAYS refer to the table below before using the KARA-PULLBACK accessory.

Possible downwards site angles with KARA-PULLBACK

Number of Kara II enclosures in the array	12	9	6	3
Number of SB18 enclosures in the array	0	3	2	1
Maximum array downwards site angle	-90°	-60°	-90°	-90°

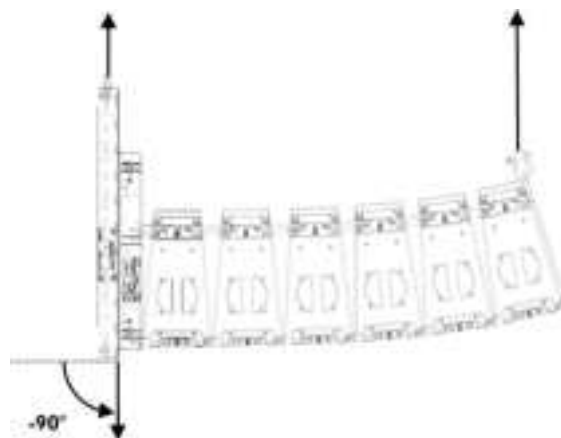

90° downwards site angle with KARA-PULLBACK

Using KARA-MINIBU

KARA-MINIBU rigging options

L-Acoustics recommends 4 different rigging options to fly the KARA-MINIBU with arrays containing Kara II and/or SB18 enclosures. It is possible to use 1 or 2 hang points and to include the KARA-MINIBUEX accessories (see figure below).

! Always refer to the mechanical data and warning indications provided in [Soundvision Software \(Mechanical Data section\)](#) to verify the mechanical conformity of the loudspeaker system before installation.

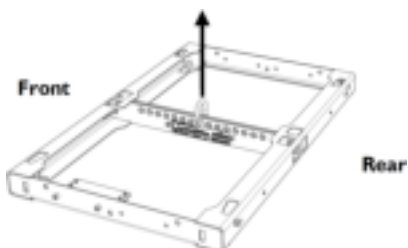

Option 1: KARA-MINIBU, 1 point

Kara II standalone array

1 motor

Variable position (see [KARA-MINIBU site angle setting](#) (p.198))

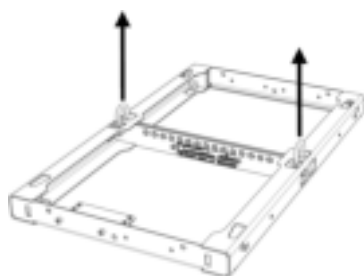

Option 2: KARA-MINIBU, 2 points

Kara II standalone array

2 motors

Fixed front and rear positions (see [KARA-MINIBU site angle setting](#) (p.198))

(spacing = 407 mm/16 inch)



Option 3: KARA-MINIBU, KARA-MINIBUEX, 1 point

SB18/Kara II mixed array or SB18 standalone array

1 motor

Variable position (see [KARA-MINIBU site angle setting](#) (p.198))

Left view = Rear extension config.

Right view = Front extension config

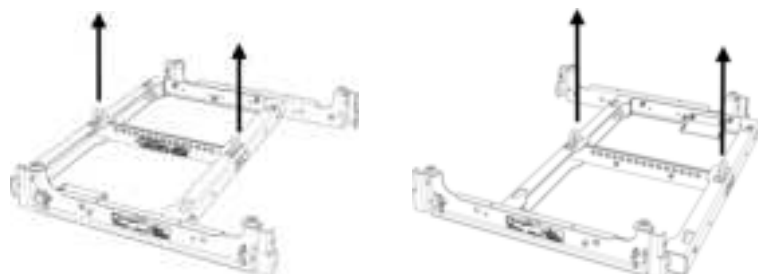

Option 4: KARA-MINIBU, KARA-MINIBUEX, 2 points

SB18/Kara II mixed array or SB18 standalone array

2 motors

Fixed front and rear positions (see [KARA-MINIBU site angle setting](#) (p.198))

(spacing = 407 mm/16 inch)

Left view = Rear extension config.

Right view = Front extension config.

KARA-MINIBU site angle setting

The KARA-MINIBU site angle setting will be discrete or continuous depending on the chosen rigging option.

Rigging options 1 and 3 offer 17 discrete site angle values in each configuration by selecting the single shackle position (holes 1-17). The hole numbering convention is shown in the figures below.

i For rigging options 1 and 3 the KARA-MINIBU site angle will also depend on the size and shape of the array (number of enclosures and inter-enclosure angles). Refer to [Soundvision Software](#) for site angle calculation.

i Hole 15 allows setting the site angle of an SB18 standalone array to 0°.

Rigging hole numbering convention for KARA-MINIBU

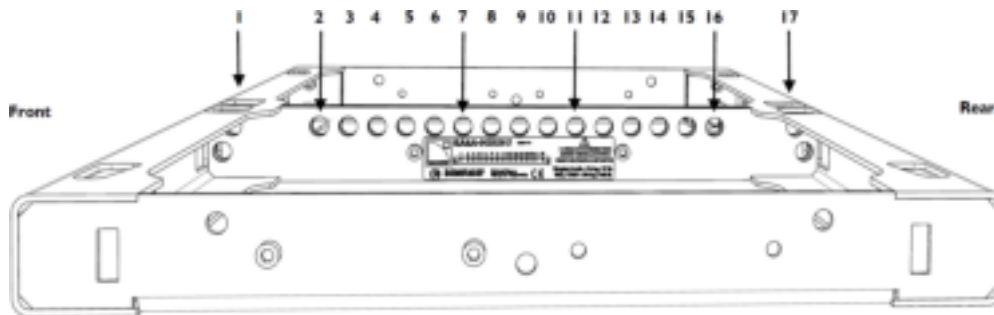

Rigging hole numbering convention for KARA-MINIBU/KARA-MINIBUEX

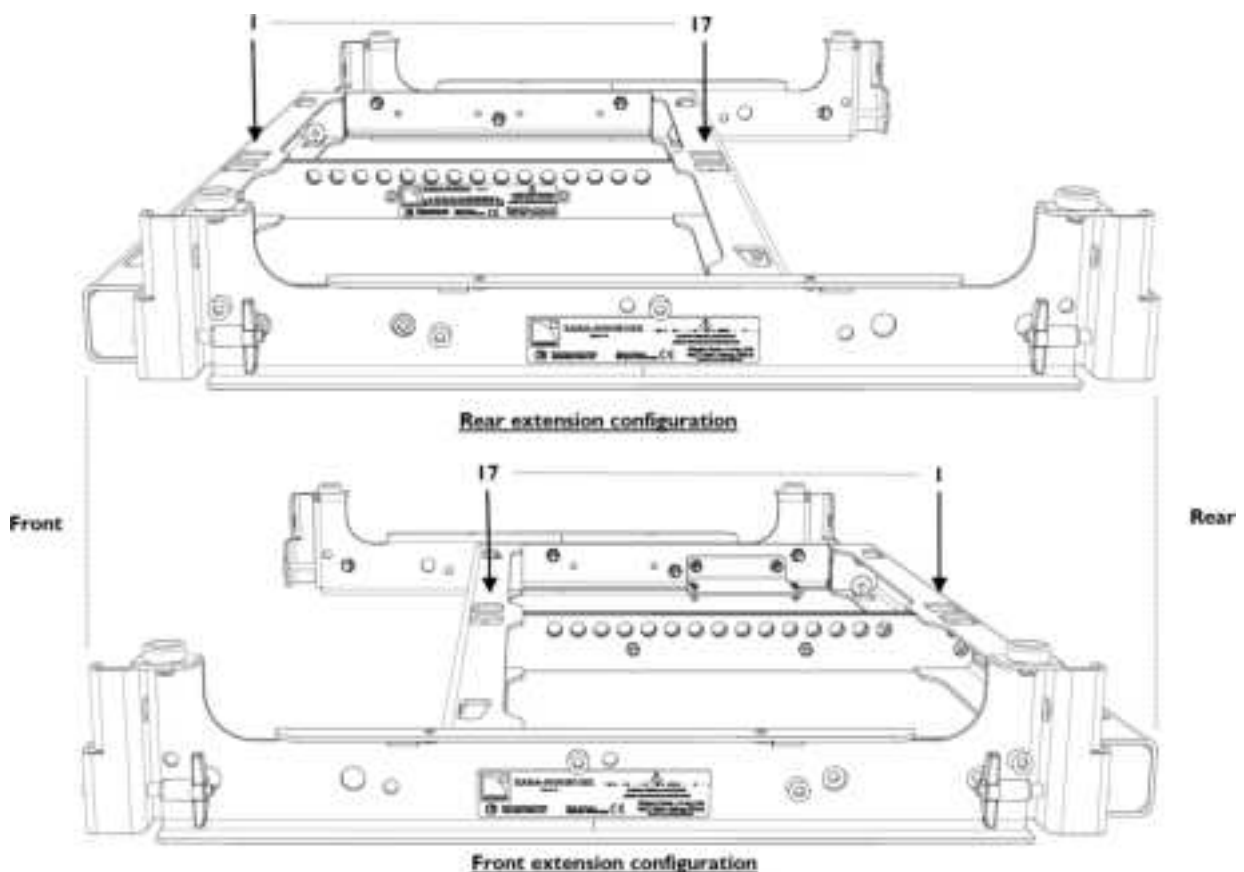

Rigging options 2 and 4 allow continuous KARA-MINIBU site angle setting depending on the relative heights between the front and rear hang points (holes 1 and 17) as shown in the figure below.

! The configurations shown in the figures below are purely indicative. Always refer to the mechanical data and warning indications provided in [Soundvision Software \(Mechanical Data section\)](#) to verify the mechanical conformity of the loudspeaker system before installation.

Continuous angle selection (option 4 examples)

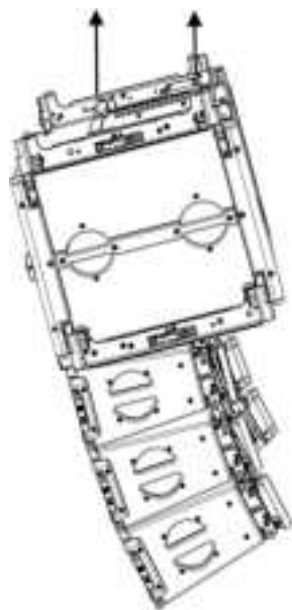

Front extension configuration and negative site angle

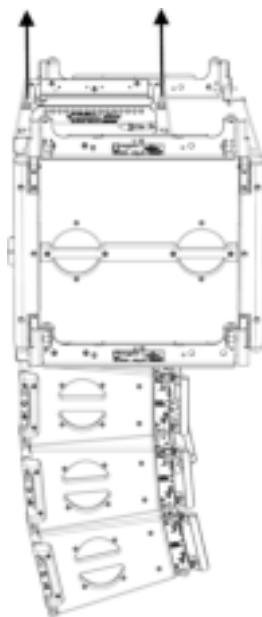

Rear extension configuration and 0° site angle

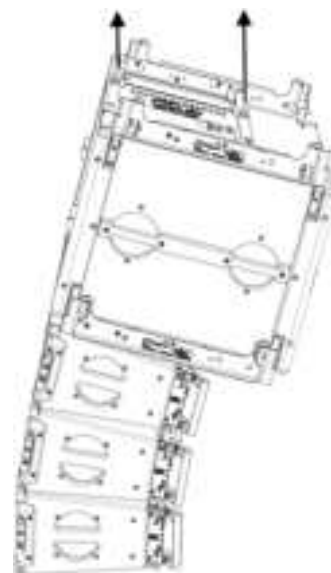

Rear extension configuration and positive site angle

KARA-PULLBACK setup safety limits

The KARA-PULLBACK accessory attaches to the bottom enclosure of a Kara II array to allow setting the site angle down to -90° so as to obtain a pullback configuration. However, this limit depends on the composition of the array as shown in the table below.

Possible downwards site angles with KARA-PULLBACK

Number of Kara II enclosures in the array	6	6	3
Number of SB18 enclosures in the array	0	2	1
Maximum array site angle	-90°	-90°	-90°

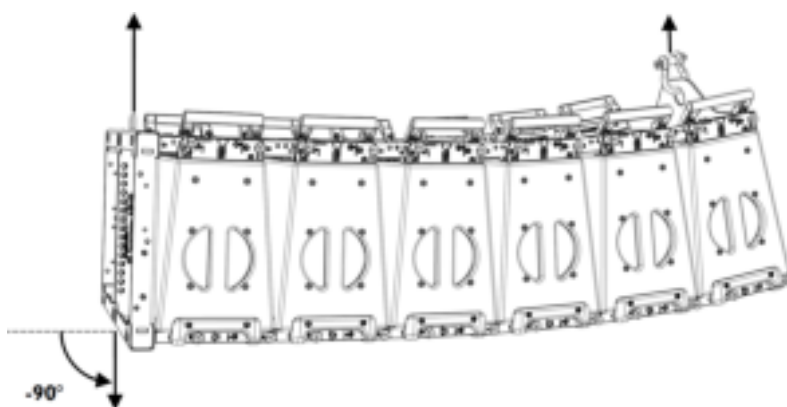

90° downwards site angle with KARA-PULLBACK

Stacked array options and site angle setting

Using M-BUMP

Stacking platform configuration

The M-BUMP can be used as a horizontal stacking platform along with two M-BAR and four M-JACK bases in front or rear extension configuration as shown in the figures below (refer to [Array site angle setting](#) (p.201) for bottom Kara II angle settings).

! The configurations shown in the figures below are purely indicative.
Refer to [Modeling and safety \(Kara II standalone array\)](#) (p.96) or [Modeling and safety \(SB18/Kara II mixed array or an SB18 standalone array\)](#) (p.121) for setup safety limits.

Rear extension configurations

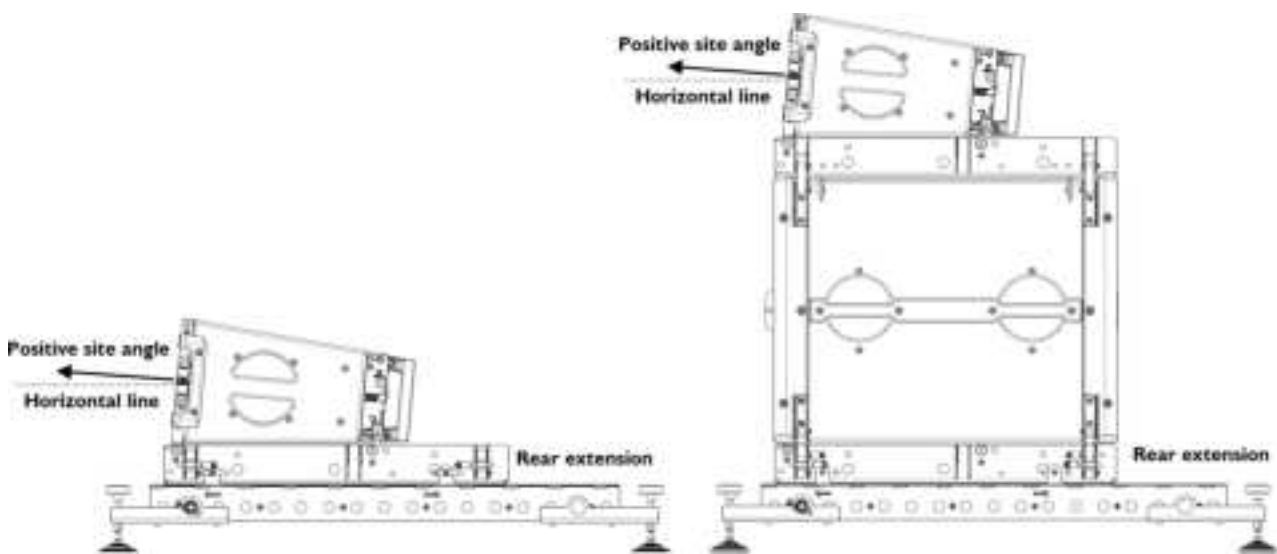

Front extension configurations

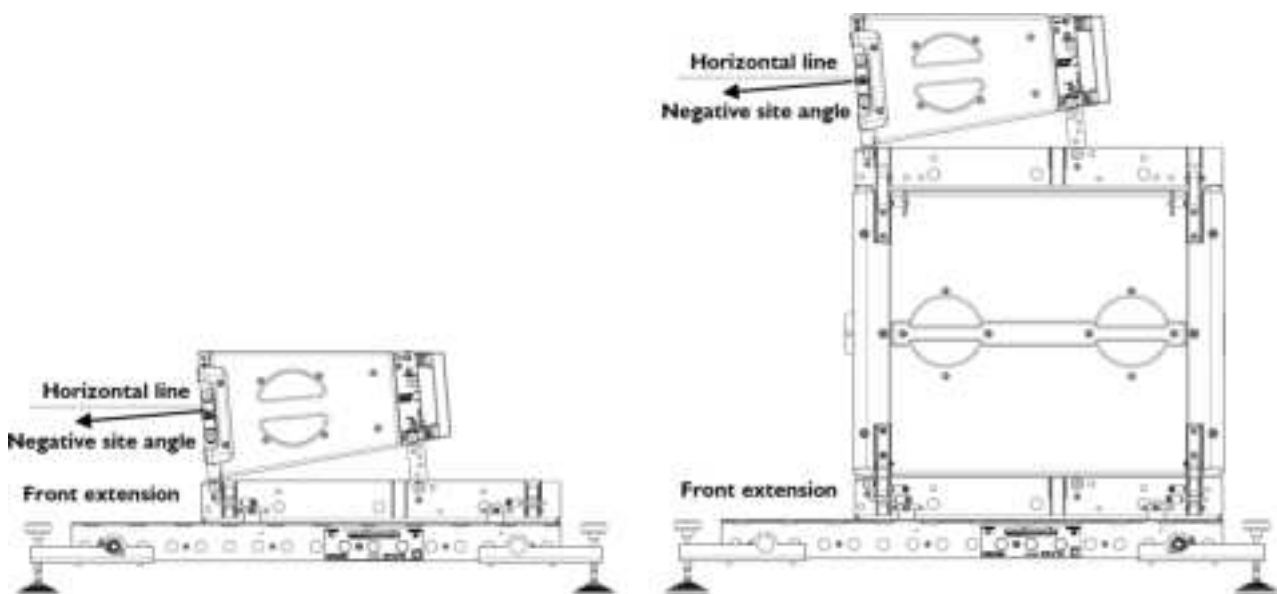

Array site angle setting

The site angle of the stacked Kara II array will be determined by the angle of the bottom enclosure in the range from -15° to $+5^{\circ}$. Install both KARA-ANGARMEX angle arm extensions (also included in the M-JACK package) to obtain angles from -7.5° to -15° . The table below gives all possible site angle settings:

Possible site angles for stacked array

Angle selection on Kara II (angle value facing the cursor)	Resulting site angle without angle arm extension	Resulting site angle with angle arm extension
0°	-5°	-15°
1°	-4°	-14°
2°	-3°	-13°
3°	-2°	-12°
4°	-1°	-11°
5°	0°	-10°
7.5°	$+2.5^{\circ}$	-7.5°
10°	$+5^{\circ}$	—

Bottom Kara II angle selection without angle arm extensions

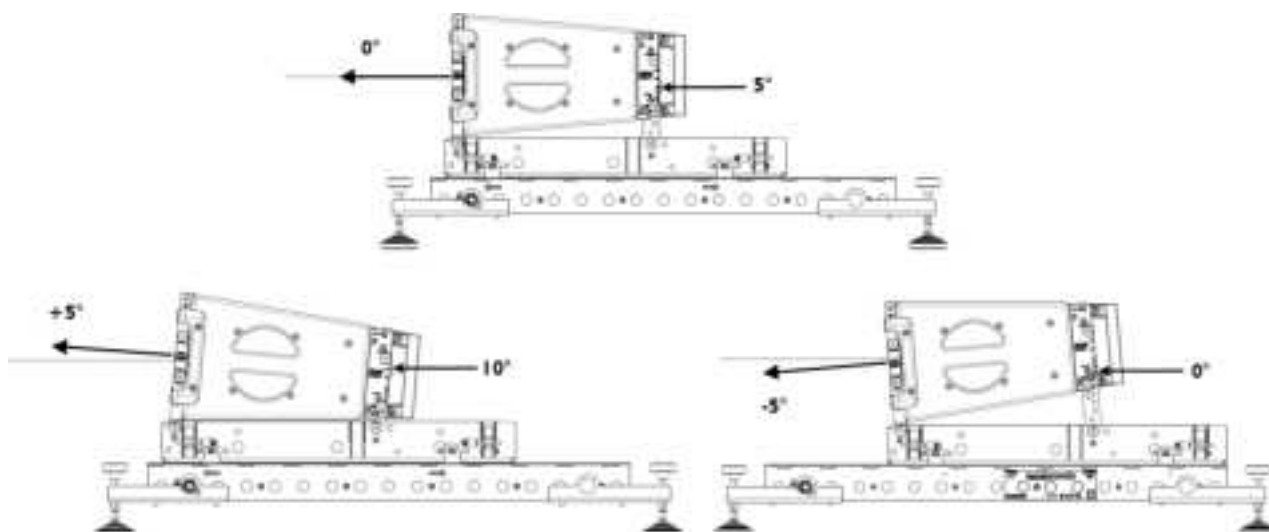

Bottom Kara II angle selection with angle arm extensions

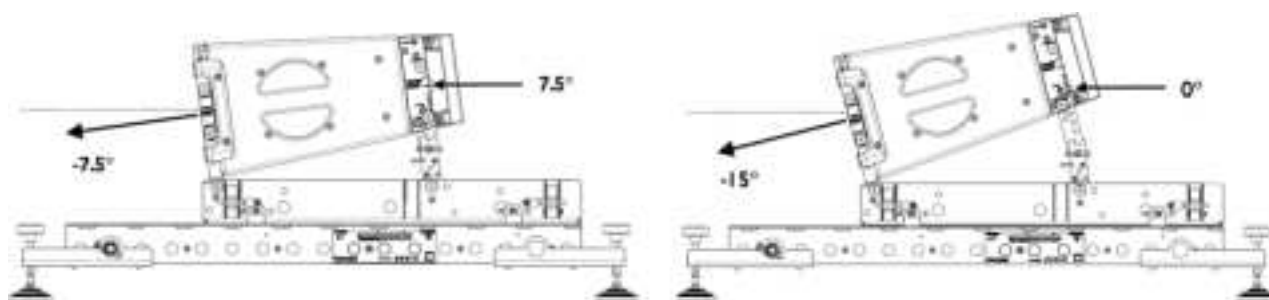

Using KARA-MINIBU

Stacking platform configuration

The KARA-MINIBU can be used as a horizontal stacking platform along with two KARA-MINIBUEX extension bars. The platform can be set in front or rear extension configuration as shown in the figures below (refer to [Array site angle setting](#) (p.203) for bottom Kara II angle setting).

 The configurations shown in the figures below are purely indicative. Refer to [Modeling and safety](#) (p.109) for setup safety limits.

Rear extension configuration

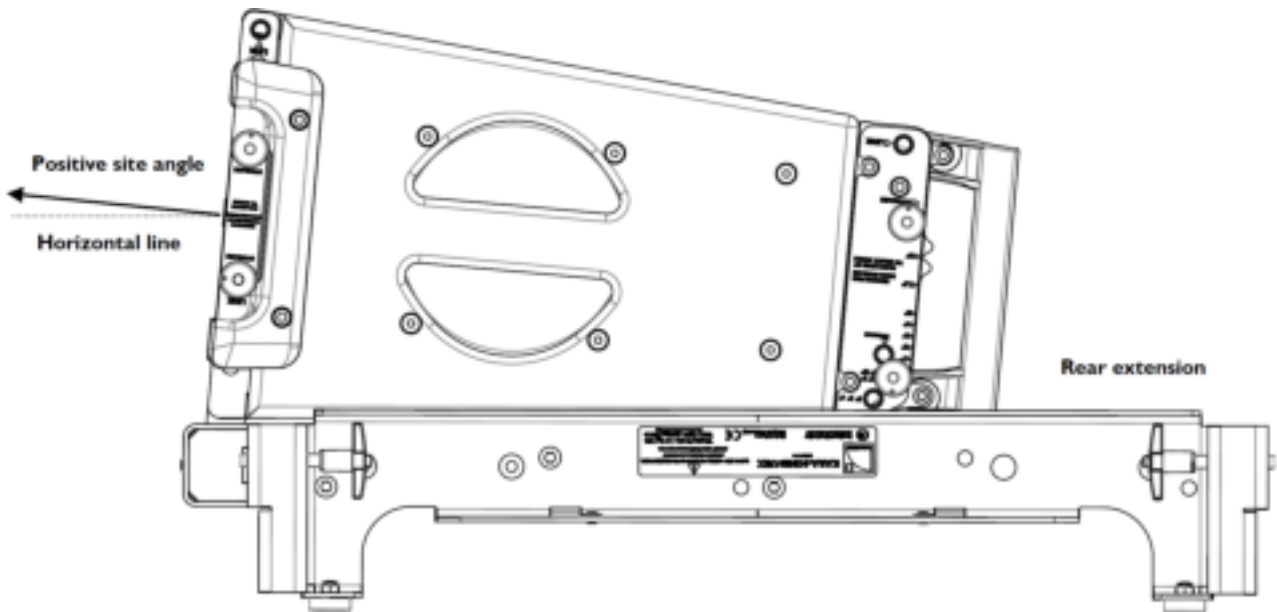

Front extension configuration

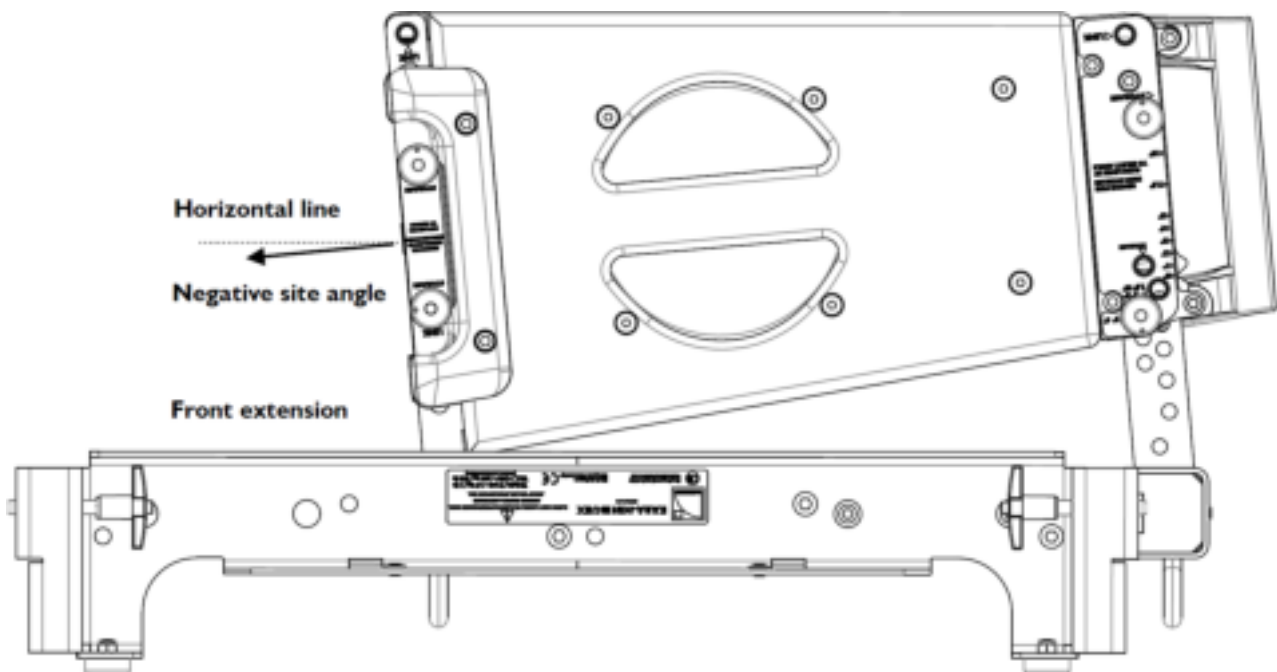

Array site angle setting

The site angle of the stacked Kara II array will be determined by the angle of the bottom Kara II enclosure, settable between -15° and $+5^\circ$. Install both KARA-ANGARMEX angle arm extensions to obtain angles from -7.5° to -15° . The table below indicates all possible site angles settings:

Possible site angles for stacked array

Angle selection on Kara II (angle value facing the cursor)	Resulting site angle without KARA-ANGARMEX	Resulting site angle with KARA-ANGARMEX
0°	-5°	-15°
1°	-4°	-14°
2°	-3°	-13°
3°	-2°	-12°
4°	-1°	-11°
5°	0°	-10°
7.5°	$+2.5^\circ$	-7.5°
10°	$+5^\circ$	—

Bottom Kara II angle selection without KARA-ANGARMEX

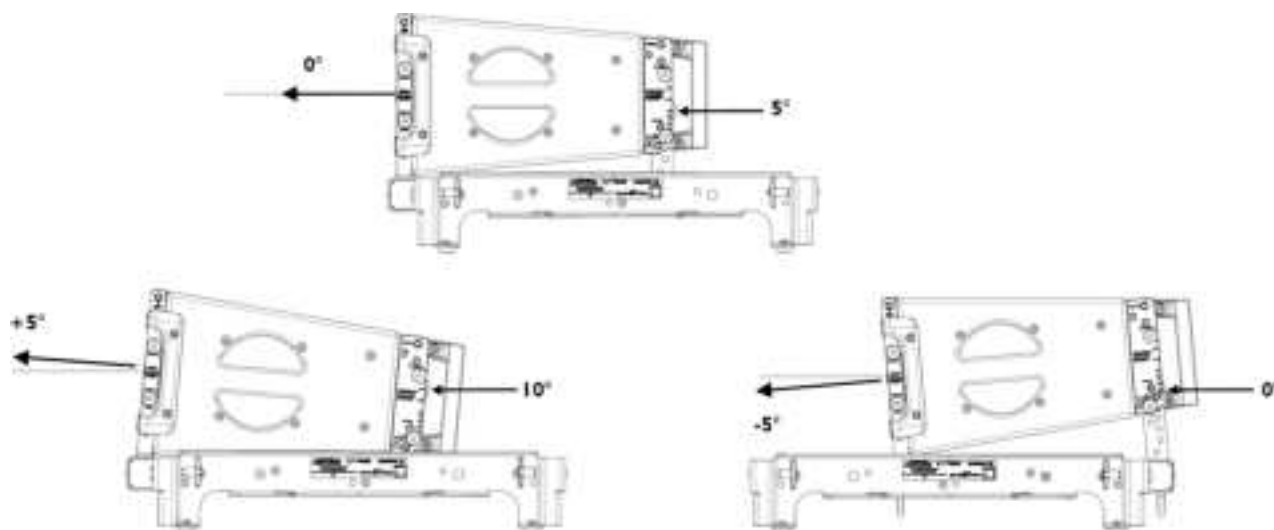

Bottom Kara II angle selection with KARA-ANGARMEX

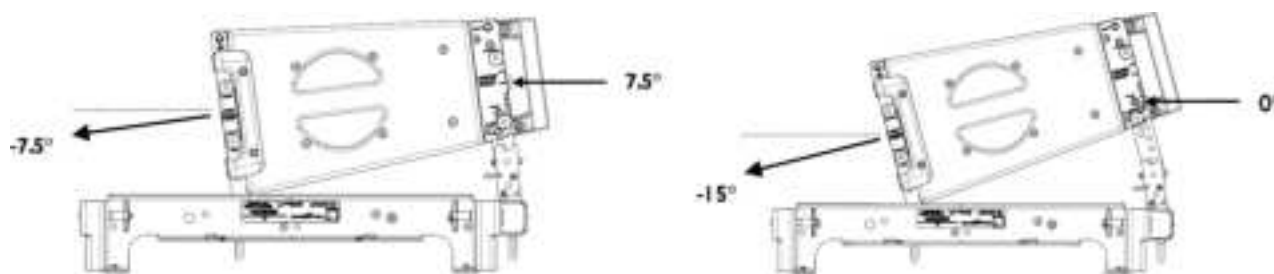

Recommendation for speaker cables

Follow the recommended maximum length for loudspeaker cables to ensure minimal SPL attenuation.



Cable quality and resistance

Only use high-quality fully insulated speaker cables made of stranded copper wire.

Use cables with a gauge offering low resistance per unit length and keep the cables as short as possible.

The table below provides the recommended maximum length for loudspeaker cables depending on the cable gauge and on the impedance load connected to the amplifier.

cable gauge			recommended maximum length					
			8 Ω load		4 Ω load		2.7 Ω load	
mm ²	SWG	AWG	m	ft	m	ft	m	ft
2.5	15	13	30	100	15	50	10	33
4	13	11	50	160	25	80	17	53
6	11	9	74	240	37	120	25	80

Use the more detailed L-Acoustics calculation tool to evaluate cable length and gauge based on the type and number of enclosures connected. The calculation tool is available on our website:

<https://www.l-acoustics.com/installation-tools/>



L-Acoustics

13 rue Levacher Cintrat - 91460 Marcoussis - France
+33 1 69 63 69 63 - info@l-acoustics.com
www.l-acoustics.com



 **L·ACOUSTICS**
GROUP