



## Ultrastar 7K3000

3.5 inch Serial Attached SCSI (SAS) Hard Disk Drive

Models:    HUS723030ALS640  
              HUS723030ALS641  
              HUS723020ALS640  
              HUS723020ALS641

**Version: 2.01**

**03 September 2013**

Warning: Printed copies of this document are considered current only on the date of print. Replacement and disposal of down-level versions is the responsibility of the document holder.

**1st Edition (Rev 2.01) (03 September 2013)**

The following paragraph does not apply to the United Kingdom or any country where such provisions are inconsistent with local law: HGST, A WESTERN DIGITAL COMPANY, PROVIDES THIS PUBLICATION "AS IS" WITHOUT WARRANTY OF ANY KIND, EITHER EXPRESS OR IMPLIED, INCLUDING, BUT NOT LIMITED TO, THE IMPLIED WARRANTIES OF MERCHANTABILITY OR FITNESS FOR A PARTICULAR PURPOSE. Some states do not allow disclaimer or express or implied warranties in certain transactions, therefore, this statement may not apply to you.

This publication could include technical inaccuracies or typographical errors. Changes are periodically made to the information herein; these changes will be incorporated in new editions of the publication. HGST may make improvements or changes in any products or programs described in this publication at any time.

It is possible that this publication may contain reference to, or information about, HGST products (machines and programs), programming, or services that are not announced in your country. Such references or information must not be construed to mean that HGST intends to announce such HGST products, programming, or services in your country.

Technical information about this product is available by contacting your local HGST representative or on the Internet at <http://www.hgst.com>

HGST may have patents or pending patent applications covering subject matter in this document. The furnishing of this document does not give you any license to these patents.

© Copyright HGST, a Western Digital company

# Table of Contents

<b>1.0 General</b> .....	<b>1</b>
1.1 Introduction.....	1
1.2 Glossary .....	2
1.3 Caution.....	2
1.4 References.....	2
<b>2.0 Outline of the Drive</b> .....	<b>3</b>
<b>3.0 Fixed-disk Subsystem Description</b> .....	<b>5</b>
3.1 Control Electronics .....	5
3.2 Head Disk Assembly .....	5
3.3 Actuator .....	5
<b>4.0 Drive Characteristics</b> .....	<b>7</b>
4.1 Formatted Capacity.....	7
4.2 Data Sheet .....	7
4.3 Inquiry Information.....	8
4.3.1 Product ID.....	8
4.3.2 World Wide ID - Block Assignment .....	8
4.4 Cylinder allocation.....	8
4.4.1 Data cylinder.....	9
4.4.2 Spare cylinder .....	9
4.5 Performance characteristics .....	9
4.5.1 Mechanical positioning.....	9
4.5.2 Drive ready time .....	10
4.5.3 Operating Modes.....	11
4.5.4 Data transfer speed: .....	12
4.5.5 Buffering operation (read ahead/write cache).....	12
<b>5.0 Data Integrity</b> .....	<b>13</b>
5.1 Equipment Status .....	13
5.2 Error Recovery Procedure.....	13
<b>6.0 Physical Format</b> .....	<b>15</b>
6.1 Shipped Format (P-List) .....	15
6.2 Reassigned Format (G-List).....	15
<b>7.0 Electrical Interface</b> .....	<b>17</b>
7.1 SAS Connector .....	17
7.1.1 29 pin Serial Attached SCSI (SAS) Connector Definition .....	17
7.1.2 Voltage and Ground Signals .....	18
7.1.3 Ready LED output .....	18
<b>8.0 Environment</b> .....	<b>19</b>
8.1 Temperature and humidity .....	19
8.2 Storage requirements .....	20
8.2.1 Packaging.....	20
8.2.2 Storage time .....	20
8.3 Corrosion test.....	20
8.4 Cooling requirements.....	21
<b>9.0 DC Power Requirements</b> .....	<b>23</b>

9.1 Power Supply Current, Average and Peak.....	24
9.2 Ripple Voltage .....	25
9.3 Power Consumption Efficiency Index .....	26
<b>10.0 Reliability .....</b>	<b>27</b>
10.1 Start/Stop Cycles.....	27
10.2 Load/Unload Cycles .....	27
10.3 Data Reliability .....	27
10.4 Seek errors .....	27
10.5 Failure prediction (S.M.A.R.T) .....	27
10.6 MTBF (Mean Time Between Failure): 2.0 M hours. ....	27
10.7 Preventive Maintenance.....	28
10.8 Temperature Warning .....	28
<b>11.0 Mechanical Specifications .....</b>	<b>29</b>
11.1 Outline .....	29
11.2 Mechanical Dimensions.....	30
11.3 Interface Connector.....	32
11.4 Mounting Positions and Tappings .....	32
11.5 Drive Mounting.....	33
11.6 Heads Unload and Actuator Lock.....	33
<b>12.0 Vibration and Shock.....</b>	<b>35</b>
12.1 Operating vibration .....	35
12.1.1 Random vibration (Linear) .....	35
12.1.2 Swept sine vibration (Linear) .....	35
12.1.3 Random vibration (Rotational) .....	35
12.2 Nonoperating vibration .....	35
12.2.1 Random vibration .....	36
12.2.2 Swept sine vibration.....	36
12.3 Operating shock .....	36
12.4 Nonoperating shock .....	36
12.4.1 Trapezoidal shock wave.....	36
12.4.2 Sinusoidal shock wave.....	36
12.5 Nonoperating Rotational shock .....	37
<b>13.0 Acoustics .....</b>	<b>39</b>
<b>14.0 Identification .....</b>	<b>41</b>
14.1 Labels.....	41
<b>15.0 Electromagnetic Compatibility.....</b>	<b>43</b>
15.1 Class B Regulatory Notices .....	43
<b>16.0 Safety Standards .....</b>	<b>45</b>
16.1 UL and C-UL Standard Conformity .....	45
16.2 European Standards Compliance .....	45
16.3 German Safety Mark.....	45
16.4 Flammability.....	45
16.5 Corporate Standards Compliance .....	45
<b>17.0 SAS Attachment.....</b>	<b>47</b>
17.1 General.....	47
17.2 SAS Features.....	47

17.3 SAS Names and Identifiers .....	48
17.4 Spin up .....	49
17.5 PHY Layer .....	50
17.5.1 Link Reset Sequence.....	50
17.5.2 Hard Reset.....	51
17.5.3 SAS OOB (Out of Band) .....	51
17.5.4 SAS Speed Negotiation .....	52
17.5.5 PHY Error Handling .....	53
17.6 Link Layer.....	53
17.6.1 Address Frames.....	53
17.6.2 Link Layer Error Handling .....	56
17.7 Transport Layer.....	58
17.7.1 Command Information Unit.....	59
17.7.2 TASK Information Units .....	60
17.7.3 XFER_RDY Information Units .....	62
17.7.4 DATA Information Units.....	62
17.7.5 RESPONSE Information Units.....	62
17.7.6 Sequences of SSP Information Units.....	64
17.7.7 Transport Layer Error Handling .....	65
<b>18.0 SCSI Command Set .....</b>	<b>67</b>
18.1 SCSI Control Byte .....	69
18.2 Abbreviations.....	69
18.3 Byte ordering conventions .....	69
18.4 FORMAT UNIT (04).....	70
18.4.1 Parameter List Header .....	72
18.4.2 Defect Descriptor .....	74
18.5 INQUIRY (12).....	78
18.5.1 Inquiry Data .....	79
18.6 LOG SELECT (4C) .....	95
18.7 LOG SENSE (4D) .....	98
18.7.1 Log Page parameters.....	99
18.7.2 Log Sense Page 0.....	100
18.7.3 Log Sense Page 2.....	101
18.7.4 Log Sense Page 3.....	103
18.7.5 Log Sense Page 5.....	105
18.7.6 Log Sense Page 6.....	107
18.7.7 Log Sense Page D .....	108
18.7.8 Log Sense Page E .....	109
18.7.9 Log Sense Page F.....	111
18.7.10 Log Sense Page 10.....	112
18.7.11 Log Sense Page 15.....	115
18.7.12 Log Sense Page 18.....	118
18.7.13 Log Sense Page 1A .....	122
18.7.14 Log Sense Page 2F.....	123
18.7.15 Log Sense Page 30.....	124
18.7.16 Log Sense Page 37.....	127

18.8 MODE SELECT (15) .....	129
18.9 MODE SELECT (55) .....	130
18.10 MODE SENSE (1A).....	131
18.10.1 Mode Parameter List.....	132
18.10.2 Mode Page 00 (Vendor Unique Parameters) .....	136
18.10.3 Mode Page 01 (Read/Write Error Recovery Parameters).....	138
18.10.4 Mode Page 02 (Disconnect/Reconnect Parameters) .....	143
18.10.5 Mode Page 03 (Format Device Parameters) .....	145
18.10.6 Mode Page 04 (Rigid Disk Drive Geometry Parameters) .....	147
18.10.7 Mode Page 07 (Verify Error Recovery Parameters).....	148
18.10.8 Mode Page 08 (Caching Parameters).....	149
18.10.9 Mode Page 0A (Control Mode Page Parameters).....	151
18.10.10 Mode Page 0C (Notch Parameters) .....	155
18.10.11 Mode Page 18h .....	156
18.10.12 Mode Page 19h (Port Control Parameters) .....	157
18.10.13 Mode Page 1A (Power Control) .....	164
18.10.14 .Mode Page 1C (Informational Exceptions Control).....	167
18.11 MODE SENSE (5A).....	170
18.12 PERSISTENT RESERVE IN (5E) .....	171
18.12.1 Service Action.....	171
18.12.2 Parameter data for Read Keys .....	172
18.12.3 Parameter Data for Read Reservations .....	173
18.13 PERSISTENT RESERVE OUT (5F) .....	174
18.13.1 Service Action.....	175
18.13.2 Type .....	175
18.13.3 Parameter list .....	176
18.13.4 Summary .....	177
18.14 PRE-FETCH (34) .....	179
18.15 PRE-FETCH (90) .....	180
18.16 READ (6) - (08).....	181
18.17 READ (10) - (28).....	182
18.18 READ (12) - (A8).....	184
18.19 READ (16) - (88).....	185
18.20 READ (32) - (7F/09).....	186
18.21 READ BUFFER (3C) .....	188
18.21.1 Combined Header And Data (Mode 00000b).....	189
18.21.2 Read Data (Mode 00010b).....	189
18.21.3 Descriptor (Mode 00011b).....	190
18.21.4 Read Data from Echo Buffer (Mode 01010b) .....	191
18.21.5 Echo Buffer Descriptor (Mode 01011b).....	191
18.21.6 Expander Communications and Echo Buffer (Mode 11010b) .....	191
18.22 READ CAPACITY (10) - (25).....	192
18.23 READ CAPACITY (16) (9E/10).....	194
18.23.1 Returned Data Format.....	194
18.24 READ DEFECT DATA (37).....	195
18.24.1 Defect List Header .....	197

18.24.2 Defect List Descriptor.....	197
18.24.3 Bytes from Index Format (100b).....	198
18.24.4 Physical Sector Format (101b).....	198
18.25 READ DEFECT DATA (B7).....	199
18.25.1 Defect List Header.....	199
18.25.2 Defect List Descriptor.....	200
18.25.3 Bytes from Index Format (100b).....	200
18.25.4 Physical Sector Format (101b).....	200
18.26 READ LONG (3E).....	201
18.27 READ LONG (9E).....	202
18.28 REASSIGN BLOCKS (07).....	203
18.29 RECEIVE DIAGNOSTICS RESULTS (1C).....	205
18.29.1 Receive Diagnostic Results Page 0.....	205
18.29.2 Receive Diagnostic Results Page 40.....	206
18.30 RELEASE (17).....	207
18.31 RELEASE (57).....	208
18.32 REPORT DEVICE IDENTIFIER (A3/05).....	209
18.33 REPORT LUNS (A0).....	211
18.34 REPORT SUPPORTED OPERATION CODES (A3/0C).....	212
18.34.1 All_commands parameter data format.....	213
18.34.2 One_command parameter data format.....	214
18.34.3 Command timeouts descriptor format.....	216
18.35 REPORT SUPPORTED TASK MANAGEMENT FUNCTIONS (A3/0D).....	217
18.36 REQUEST SENSE (03).....	219
18.37 RESERVE (16).....	220
18.38 RESERVE (56).....	221
18.39 REZERO UNIT (01).....	222
18.40 SEND DIAGNOSTIC (1D).....	223
18.40.1 Send Diagnostic Page 0.....	225
18.40.2 Send Diagnostic Page 3F.....	225
18.40.3 Send Diagnostic Page 40.....	228
18.41 SET DEVICE IDENTIFIER (A4/06).....	230
18.42 START STOP UNIT (1B).....	231
18.43 SYNCHRONIZE CACHE (10) - (35).....	234
18.44 SYNCHRONIZE CACHE (16) - (91).....	235
18.45 TEST UNIT READY (00).....	236
18.46 VERIFY (10) (2F).....	237
18.47 VERIFY (12) - (AF).....	240
18.48 VERIFY (16) - (8F).....	241
18.49 VERIFY (32) - (7F/0A).....	242
18.50 WRITE (6) - (0A).....	244
18.51 WRITE (10) - (2A).....	245
18.52 WRITE (12) - (AA).....	248
18.53 WRITE (16) - (8A).....	249
18.54 WRITE (32) - (7F/0B).....	250
18.55 WRITE AND VERIFY (10) - (2E).....	252

18.56 WRITE AND VERIFY (12) - (AE).....	253
18.57 WRITE AND VERIFY (16) - (8E).....	254
18.58 WRITE AND VERIFY (32) - (7F/0C).....	255
18.59 WRITE BUFFER (3B) .....	256
18.59.1 Combined Header And Data (Mode 00000b).....	256
18.59.2 Write Data (Mode 00010b).....	257
18.59.3 Download Microcode (Mode 00100b) .....	257
18.59.4 Download Microcode and Save (Mode 00101b) -Single Binary File .....	258
18.59.5 Download Microcode and Save (Mode 00111b) - Multiple Binary Files ....	258
18.59.6 Write Data to Echo Buffer (Mode 01010b).....	258
18.59.7 Enable Expander Communications Protocol (Mode 11010b).....	259
18.60 WRITE LONG (10) (3F) .....	260
18.61 WRITE LONG (16) (9F) .....	262
18.62 WRITE SAME (10) - (41).....	263
18.63 WRITE SAME (16) - (93).....	264
18.64 WRITE SAME (32) - (7F/0D).....	265
<b>19.0 SCSI Status Byte .....</b>	<b>267</b>
<b>20.0 Additional information.....</b>	<b>269</b>
20.1 SCSI Protocol .....	269
20.1.1 Priority of SCSI Status Byte Reporting.....	269
20.1.2 Invalid LUN Processing.....	269
20.1.3 Overlapped Commands.....	270
20.1.4 Command Processing During Execution of Active I/O Process .....	270
20.1.5 Unit Attention Condition .....	271
20.1.6 Command Processing During Startup and Format Operations.....	273
20.1.7 Internal Error Condition.....	273
20.1.8 Deferred Error Condition.....	273
20.1.9 Degraded Mode.....	274
20.1.10 Command Processing while Reserved.....	281
20.2 Priority Commands .....	281
20.3 Command Queuing .....	282
20.3.1 Queue Depth .....	282
20.3.2 Queue Full Status.....	282
20.3.3 Termination of I/O Processes .....	282
20.4 Command Reordering.....	282
20.5 Concurrent I/O Process .....	282
20.6 Write Cache .....	282
20.7 Automatic Rewrite/Reallocate.....	283
20.8 Segmented Caching .....	285
20.8.1 Overview.....	285
20.8.2 Read Ahead.....	285
20.9 Multiple Initiator Systems .....	285
20.9.1 Sense Data.....	285
20.9.2 Mode Pages.....	285
20.10 Multiple Initiator Environment.....	285
20.10.1 Initiator Sense Data.....	285



20.10.2 Initiator Mode Select/Mode Sense Parameters .....	285
20.11 Reset.....	286
20.11.1 Reset Sources .....	286
20.11.2 Reset Actions .....	286
20.12 Diagnostics.....	286
20.12.1 Power on Diagnostics .....	286
20.12.2 Self-test via SEND DIAGNOSTIC Command.....	287
20.13 Idle Time Function.....	290
20.14 Command Time out Limits .....	290
20.14.1 Reassignment Time.....	290
20.14.2 Format Time .....	290
20.14.3 Start/Stop Unit Time.....	290
20.14.4 Medium Access Command Time .....	291
20.14.5 Time-out Limits for Other Commands .....	291
20.15 Recommended Initiator ERP .....	292
20.15.1 Drive Service Strategy .....	292
20.15.2 Recommendations for System Error Log .....	293
20.15.3 Data Recovery Procedure .....	293
20.15.4 Nondata Error Recovery Procedure .....	295
<b>21.0 TCG SSC .....</b>	<b>303</b>
21.1 Referenced Specifications and Standards .....	303
21.1.1 TCG Specifications.....	303
21.1.2 Federal Information Processing Standards (FIPS).....	303
21.1.3 National Institute of Standards (NIST).....	303
21.1.4 Department of Defense .....	303
21.1.5 RSA Laboratories Standards.....	304
21.1.6 Other Standards.....	304
21.2 Implementation Exceptions .....	304
21.3 Implementation Features and Details Outside of TCG Specifications .....	304
21.4 Encryption Algorithms .....	305
21.4.1 Advanced Encryption Standard (AES) Support .....	305
21.4.2 Level 0 Discovery Vendor Specific Data .....	305
21.4.3 Pseudo Random Number Generation (PRNG).....	306
21.4.4 Key Wrapping.....	306
21.4.5 Key Erasure.....	306
21.5 -TCG SSC Tables .....	306
21.5.1 Admin SP C_PIN Table and Locking SP C_PIN Table .....	307
21.5.2 K_AES_256 Table.....	307
21.5.3 Locking SP AccessControl Table .....	307
21.5.4 Locking Info Table .....	308
21.5.5 Locking SP Locking Table .....	308
21.6 Firmware Download and Signing .....	309
21.7 MSID .....	312
21.8 Logging.....	312
21.9 Number of Sessions .....	312
21.10 Number of Bands .....	312

21.11	Number of COMIDs .....	312
21.12	Locked and Unlocked Behavior .....	312
21.12.1	T10 SCSI commands .....	312
21.12.2	TCG SSC Commands .....	314
21.13	Error Codes .....	316
<b>22.0</b>	<b>SCSI Sense Data.....</b>	<b>317</b>
22.1	SCSI Sense Data Format Introduction .....	317
22.1.1	Sense Data Format .....	317
22.1.2	Sense Data Length .....	317
22.1.3	Sense Data Response Code.....	317
22.2	Fixed Format Sense Data .....	318
22.2.1	Valid (Bit 7 of byte 0).....	318
22.2.2	Response Code (Bit 6 - 0 of byte 0).....	318
22.2.3	ILI: Incorrect Length Indicator (Bit 5 of byte 2) .....	319
22.2.4	Sense Key (Bit 3 - 0 of byte 2) .....	319
22.2.5	Information Bytes (Byte 3 through 6).....	320
22.2.6	Additional Sense Length (Byte 7) .....	320
22.2.7	Command Specific Information (Byte 8 through 11).....	320
22.2.8	Additional Sense Code/Qualifier (Byte 12 and 13) .....	320
22.2.9	FRU: Field Replaceable Unit (Byte 14) .....	349
22.2.10	Sense Key Specific (Byte 15 through 17).....	349
22.2.11	Reserved (Byte 18 through 19).....	353
22.2.12	Vendor unique error information (Byte 20 through 23) .....	353
22.2.13	Physical Error Record (Product Specific Information) (Byte 24 thru 29)...	353
22.3	Descriptor Format Sense Data .....	354
22.3.1	Order of Sense Descriptors .....	355
22.3.2	Sense Data Descriptor Definitions.....	355
<b>23.0</b>	<b>Appendix. UEC list .....</b>	<b>359</b>

# List of Tables

Table 1.Product ID table .....	1
Table 2.Formatted Capacity .....	7
Table 3.Data Sheet .....	7
Table 4.Product ID in Inquiry Command .....	8
Table 5.Block assignment of World Wide ID in INQUIRY Command.....	8
Table 6.Mechanical positioning performance .....	9
Table 7.Full stroke seek time .....	10
Table 8.Latency time .....	10
Table 9.Drive ready time .....	10
Table 10.Mode transition times .....	11
Table 11.Data transfer speed (sector size 512 Byte case).....	12
Table 12.29-pin Connector Signal Definition.....	17
Table 13.Operating and non-operating conditions .....	19
Table 14.Maximum allowable surface temperatures .....	21
Table 15.Input Voltage and capacitance.....	23
Table 16.Power Supply Generated Ripple at Drive Power Connector.....	25
Table 17.Power Consumption Efficiency Index.....	26
Table 18.Physical Dimensions.....	31
Table 19.Random vibration PSD profile break points (operating).....	35
Table 20.Random vibration (Rotational) PSD profile break points (TBD).....	35
Table 21.Random vibration PSD profile break points (non operating).....	36
Table 22. Sinusoidal shock wave.....	36
Table 23. Sinusoidal shock wave.....	37
Table 24.Sound power levels.....	39
Table 25.Names and identifiers .....	48
Table 26.IEEE Registered Name format .....	49
Table 27.Supported Settings Bit Priorities .....	52
Table 28.Address Frame Format .....	53
Table 29.Frame type: .....	54
Table 30.Identify Address Frame .....	54
Table 31.Reason field .....	55
Table 32.SAS Frame Format .....	58
Table 33.COMMAND Information Unit.....	59
Table 34.TASK Information Unit.....	60
Table 35.Additional Response Information argument for Query Async Event.....	61
Table 36.UADE DEPTH field .....	61
Table 37.XFER_RDY Information Unit .....	62
Table 38.DATA Information Unit .....	62
Table 39.Response Information Unit.....	62
Table 40.RESPONSE DATA .....	64
Table 41.SCSI Commands Supported .....	67
Table 42.SCSI Control Byte .....	69
Table 43.FORMAT UNIT (04) .....	70

Table 44.Format of the Parameter List Header.....	72
Table 45.Initialization Pattern Descriptor:.....	73
Table 46.Defect Descriptor - Block Format (for n + 1 defects) .....	75
Table 47.Defect Descriptor - Bytes From Index Format (for n = 1 defects) .....	76
Table 48.Defect Descriptor - Physical Sector Format (for n + 1 defects) .....	77
Table 49.INQUIRY (12).....	78
Table 50.Page Code descriptions.....	78
Table 51.Inquiry Data- EVPD = 0 .....	79
Table 52.Inquiry Data - EVPD = 1 (Page Code = 00h).....	80
Table 53.Inquiry Data - EVPD = 1 (Page Code = 03h).....	82
Table 54.Inquiry Data - EVPD = 1 (Page Code = 80h).....	84
Table 55.Inquiry Data Format - EVPD = 1, (Page Code - 83h) .....	85
Table 56.Inquiry Data Format - EVPD = 1, (Page Code - 86h) .....	86
Table 57.Inquiry Data Format - EVPD = 1, (Page Code - 87h) .....	87
Table 58.Inquiry Data Format - EVPD = 1, (Page Code - 88h) .....	88
Table 59.Inquiry Data Format - EVPD = 1, (Page Code - 8Ah) .....	90
Table 60.Inquiry Data - EVPD = 1 (Page Code = 90h).....	91
Table 61.Protocol-specific logical unit information descriptor .....	91
Table 62.Inquiry Data - EVPD = 1 (Page Code = B1h) .....	92
Table 63.Inquiry Data - EVPD = 1 (Page Code = D1h).....	93
Table 64.Inquiry Data - EVPD = 1 (Page Code = D2h).....	94
Table 65.Log Select (4C).....	95
Table 66.Log Sense (4D).....	98
Table 67.Log Sense Page 0.....	100
Table 68.Log Sense Page 2 (part 1 of 2).....	101
Table 69.Log Sense Page 2 (part 2 of 2).....	101
Table 70.Log Sense Page 3 (part 1 of 2).....	103
Table 71.Log Sense Page 3 (part 2 of 2).....	103
Table 72.Log Sense Page 5 (part 1 of 2).....	105
Table 73.Log Sense Page 5 (part 2 of 2).....	106
Table 74.Log Sense Page 6.....	107
Table 75.Log Sense Page D.....	108
Table 76.Log Sense Page E .....	109
Table 77.Log Sense Page F.....	111
Table 78.Log Sense Page F, Application Client Log .....	111
Table 79.Log Sense Page 10.....	112
Table 80.Log Sense Page 10, self-test results.....	112
Table 81.Log Sense Page 10, self-test results.....	113
Table 82.Log Sense Page 10, Extended Segment Number.....	114
Table 83.Log Sense Page 15.....	115
Table 84.Log Sense Page 18.....	118
Table 85.SAS Log Descriptor.....	118
Table 86.Log Sense Page 1A .....	122
Table 87. Log Sense Page 2F.....	123
Table 88.Log Sense Page 30.....	124
Table 89.Log Sense Page 37.....	127

Table 90.Mode Select (15).....	129
Table 91.Mode Select (55).....	130
Table 92.Mode Sense (1A).....	131
Table 93.Page Code Usage.....	132
Table 94.Mode parameter header (6).....	132
Table 95.Mode parameter header (10).....	133
Table 96.Short LBA Mode Parameter Block Descriptor.....	134
Table 97.Long LBA Mode Parameter Block Descriptor.....	134
Table 98.Mode Parameter Page Format.....	135
Table 99.Mode Parameter Page Format.....	135
Table 100.Vendor Unique Parameters - Page 00.....	136
Table 101.Mode Page 01 (Vendor Unique Parameters).....	138
Table 102.Mode Page 02 (Disconnect/Reconnect Parameters).....	143
Table 103.Mode Page 03 (Format Device Parameters).....	145
Table 104.Mode Page 04 (Rigid Disk Drive Geometry Parameters).....	147
Table 105.Mode Page 07 (Verify Error Recovery Parameters).....	148
Table 106.Page 08 (Caching Parameters).....	149
Table 107.Page 0A (Control Mode Page Parameters).....	151
Table 108.Application Tag mode page:.....	153
Table 109.Application Tag descriptor format.....	153
Table 110.Control Extension Subpage.....	154
Table 111.Page 0C (Notch Parameters).....	155
Table 112.Page 18h (Protocol-Specific Logical Unit mode page).....	156
Table 113.Short (Port Control Parameters) Short Format.....	157
Table 114.Long Format of Port Control Page.....	158
Table 115.PHY Control and Discover (Subpage 1).....	160
Table 116.SAS PHY Mode Descriptor.....	161
Table 117.Shared Port Control (Subpage 2).....	162
Table 118.Subpage 3.....	163
Table 119.PHY Mode Descriptor (0 and 1).....	163
Table 120.Page 1A (Power Control).....	164
Table 121.PM_BG_PRECEDENCE field.....	165
Table 122.Page 1C (Informational Exceptions Control).....	167
Table 123.Background Control (Subpage 01h).....	169
Table 124.Mode Sense (5A).....	170
Table 125.Persistent Reserve In (5E).....	171
Table 126.PERSISTENT RESERVE IN, Service Action Codes.....	171
Table 127.PERSISTENT RESERVE IN, parameter data for Read Keys.....	172
Table 128.PERSISTENT RESERVE IN, parameter data for Read Reservations.....	173
Table 129.PERSISTENT RESERVE IN, Read Reservation Descriptor.....	173
Table 130.PERSISTENT RESERVE OUT (5F).....	174
Table 131.PERSISTENT RESERVE OUT, Service Action Code.....	175
Table 132.PERSISTENT RESERVE OUT, Type Code.....	175
Table 133.Parameter List.....	176
Table 134.PERSISTENT RESERVE OUT, Service Action, Parameters.....	177
Table 135.APTPL and information held by a drive.....	178

Table 136.PRE-FETCH (34) .....	179
Table 137.PRE-FETCH (34) .....	180
Table 138.READ (6) - (08).....	181
Table 139.READ (10) - (28) .....	182
Table 140.Read (12) - (A8).....	184
Table 141.READ (16) - (88).....	185
Table 142.READ (32) - (7F/09) .....	186
Table 143.READ BUFFER (3C) .....	188
Table 144.Read Buffer Header .....	189
Table 145.Read Buffer Description .....	190
Table 146.Echo Buffer Descriptor.....	191
Table 147.READ CAPACITY (10) - (25).....	192
Table 148.Format of READ CAPACITY command reply.....	193
Table 149.Read Capacity (16) (9E/10).....	194
Table 150.Returned Data Format.....	194
Table 151.READ DEFECT DATA (37).....	195
Table 152.Defect List Format .....	196
Table 153.Defect List Header .....	197
Table 154.Defect List Descriptor.....	197
Table 155.Defect Descriptors of Bytes from Index Format .....	198
Table 156.Defect Descriptors of Physical Sector Format.....	198
Table 157.READ DEFECT DATA (B7) .....	199
Table 158.Defect List Header .....	199
Table 159.Defect List Descriptor.....	200
Table 160.Defect Descriptors of Bytes from Index Format .....	200
Table 161.Defect Descriptors of Physical Sector Format.....	200
Table 162.READ LONG (3E) .....	201
Table 163.READ LONG (9E) .....	202
Table 164.REASSIGN BLOCKS (07) .....	203
Table 165.Format of Reassign Blocks Parameter List data .....	204
Table 166.RECEIVE DIAGNOSTIC RESULTS (1C) .....	205
Table 167.Receive Diagnostic Results page 0.....	205
Table 168.Receive Diagnostic Results Page 40.....	206
Table 169.Translated address .....	206
Table 170.RELEASE (17) .....	207
Table 171.RELEASE (57) .....	208
Table 172.REPORT DEVICE IDENTIFIER (A3/05).....	209
Table 173.Report Device Identifier parameter list .....	210
Table 174.REPORT LUNS (A0) .....	211
Table 175.LUN Reporting parameter list format.....	211
Table 176.REPORT SUPPORTED OPERATION CODES (A3/0C) .....	212
Table 177.Reporting Options.....	212
Table 178.All_command parameter data format .....	213
Table 179.Command Descriptor format .....	213
Table 180. One_command parameter data format.....	214
Table 181.One_command parameter support field.....	215

Table 182.Command timeouts descriptor format .....	216
Table 183.Command timeouts descriptor Command Specific Field usage .....	216
Table 184.Report Supported Task Management Functions (A3/0D) .....	217
Table 185.REQUEST SENSE (03) .....	219
Table 186.Sense Data Format and Length .....	219
Table 187.RESERVE (16).....	220
Table 188.RESERVE (56).....	221
Table 189.REZERO UNIT (01).....	222
Table 190.SEND DIAGNOSTIC (1D).....	223
Table 191.SEND DIAGNOSTIC Function Code (1D) .....	224
Table 192.Diagnostic Page 0 .....	225
Table 193.Diagnostic Page 3F.....	225
Table 194.Diagnostic Page 40 .....	228
Table 195.Address to translate.....	229
Table 196.SET DEVICE IDENTIFIER (A4/06).....	230
Table 197.SET DEVICE IDENTIFIER, Parameter List .....	230
Table 198.START STOP UNIT (1B).....	231
Table 199.Power Conditions: .....	232
Table 200.SYNCHRONIZE CACHE (10) - (35).....	234
Table 201.Synchronize Cache (16) - (91).....	235
Table 202.TEST UNIT READY (00).....	236
Table 203.VERIFY (10)(2F) .....	237
Table 204.Verify (12) - (AF) .....	240
Table 205.Verify (16) - (8F).....	241
Table 206.Verify (32) - 7F/0A) .....	242
Table 207.WRITE (6) - (0A) .....	244
Table 208.WRITE (10) - (2A) .....	245
Table 209.Write (12) - (AA).....	248
Table 210.Write (16) - (8A).....	249
Table 211.Write (32) - (7F/0B).....	250
Table 212.WRITE AND VERIFY (10) - (2E) .....	252
Table 213.Write and Verify (12) - (AE).....	253
Table 214.Write and Verify (16) - (8E).....	254
Table 215.Write and Verify (32) - (7F/0C) .....	255
Table 216.WRITE BUFFER (3B) .....	256
Table 217.Write Buffer Header .....	257
Table 218.WRITE LONG (3F).....	260
Table 219.WRITE LONG (9F).....	262
Table 220.WRITE SAME (41).....	263
Table 221.Write Same (16) - (93).....	264
Table 222.Write Same (32) - (7F/0D) .....	265
Table 223.SCSI Status Byte. Format of the SCSI STATUS byte. ....	267
Table 224.Spindle Motor Degraded Mode - Disable Auto Start .....	275
Table 225.Spindle Motor Degraded Mode - Auto Start Delay/Spinning Up .....	276
Table 226.Spindle Motor Degraded Mode - Spindle Start Failure.....	277
Table 227.Spindle Motor Degraded Mode - Spindle Stopped by Command .....	278

Table 228.Self Configuration Failure Degraded Mode .....	279
Table 229.Format Command Failure Degraded Mode .....	280
Table 230.Sense data combinations with auto/recommend rewrite/reallocate .....	284
Table 231.Short and Extended Self-Test Description .....	289
Table 232.Recommend Reassign Errors .....	294
Table 233.Log Only Errors .....	294
Table 234.Persistent Reserve In (5E) .....	305
Table 235.HGST Implementation of Admin SP_CPIN & Locking C_PIN .....	307
Table 236.HGST Implementation of K_AES_256 Table .....	307
Table 237.HGST Implementation of Locking SP Access Control Table .....	308
Table 238.HGST Implementation of Locking Info Table .....	308
Table 239.HGST Implementation of Locking SP Locking Table .....	308
Table 240.Ports Functionality .....	310
Table 241.Ports Table .....	310
Table 242.Modified Admin SP ACE Table .....	310
Table 243.Modified Admin SP AccessControl Table .....	311
Table 244.T10 SCSI Commands Behavior Table .....	313
Table 245.TCG Enterprise SSC Commands Behavior .....	315
Table 246.Sense data response codes. ....	317
Table 247.Fixed Format of Sense Data. ....	318
Table 248.Field Pointer Bytes .....	350
Table 249.Actual Retry Count .....	351
Table 250.Progress Indication .....	352
Table 251.Descriptor Format Sense Data .....	354
Table 252.Sense Data Descriptor Format .....	354
Table 253.Supported Descriptor Types .....	354
Table 254.Sense Data Descriptor List .....	355
Table 255.Information Sense Data Descriptor Format .....	355
Table 256.Command-specific Sense Data Descriptor Format .....	356
Table 257.Information Sense Data Descriptor Format .....	356
Table 258.Field Replaceable Unit Sense Data Descriptor Format .....	357
Table 259.Block Command Sense Data Descriptor Format .....	357
Table 260.Vendor Unique Unit Error Code Sense Data Descriptor .....	358
Table 261.Vendor Unique Physical Error Record Sense Data Descriptor .....	358
Table 262.Unit Error Codes .....	359



# 1.0 General

## 1.1 Introduction

This document describes the specifications of the following HGST 3.5 inch SAS drives.

**Table 1: Product ID table**

<b>Drive Name</b>	<b>Model Name</b>	<b>Type</b>	<b>Capacity</b>	<b>Encryption Enabled</b>
Ultrastar 7K3000	<b>HUS723030ALS640</b>	DK7SSD300	3TB	No
Ultrastar 7K3000	<b>HUS723030ALS641</b>	DK7SSD300	3TB	Yes
Ultrastar 7K3000	<b>HUS723020ALS640</b>	DK7SSD200	2TB	No
Ultrastar 7K3000	<b>HUS723020ALS641</b>	DK7SSD200	2TB	Yes

**Note:** The specifications in this document are subject to change without notice.  
For technical and ordering information, please visit our website at <http://www.hGSTgst.com>.

## 1.2 Glossary

<b>Word</b>	<b>Meaning</b>
ESD	Electrostatic Discharge
Kbpi	1,000 bits per inch
Ktpi	1,000 tracks per inch
Gbps	1,000,000,000 bits per second
Mbps	1,000,000 bits per second
MB/s	1,000,000 bytes per second
TB	1,000,000,000,000 bytes (for Drive Capacity)
GB	1,000,000,000 bytes (for Drive Capacity)
MB	1,048,576 bytes (for Memory Size)
KB	1,024 bytes (for Memory Size)
S.M.A.R.T.	Self-Monitoring Analysis and Reporting Technology
DFT	Drive Fitness Test
ADM	Automatic Drive Maintenance

## 1.3 Caution

This drive can be damaged by ESD (Electric Static Discharge). Any damages incurred to the drive after its removal from the shipping package and the ESD protective bag are the responsibility of the user.

## 1.4 References

- SAS Compliance
  - "Serial Attached SCSI - 2 (SAS-2)"
- SAS Protocol
  - This drive supports Serial Scsi Protocol (SSP).
  - STP (Tunneled SATA) and SMP (Management protocol) protocols are NOT supported.

## 2.0 Outline of the Drive

- Data capacities of 2TB/3TB
- Spindle speeds of 7200 RPM
- Fluid Dynamic Bearing motor
- Dual Stage Actuator
- SAS Interface 6/3/1.5Gbps
- Supports dual-ported operations
- Supports full duplex operations
- Variable sector size (512 - 528 bytes in multiples of eight)
- Closed-loop actuator servo
- Load/Unload mechanism, non head disk contact start/stop
- Automatic Actuator lock
- Seek time of 7.6 ms seek time in read operation
- Sector Buffer size of 64MB  
(Upper TBD KB is used for firmware, this is typical value, it depends on firmware revision)
- Write Cache
- Back to back write
- ECC On The Fly correction
- Automatic defect reallocation
- Self diagnostics at power on
- Power saving modes/Low RPM idle mode (APM)
- S.M.A.R.T. (Self Monitoring and Analysis Reporting Technology)
- 64 bit addressing feature
- Adaptive zone formatting
- RVS (Rotational Vibration Safeguard)
- SAS-2 compliant
- ANSI T10 Protection Information (End-to-End)
- Support TCG Enterprise\_A SSC Encryption (specific model only)



## **3.0 Fixed-disk Subsystem Description**

### **3.1 Control Electronics**

The drive is electronically controlled by a microprocessor, several logic modules, digital/analog modules, and various drivers and receivers. The control electronics performs the following major functions:

- Controls and interprets all interface signals between the host controller and the drive.
- Controls read write accessing of the disk media, including defect management and error recovery.
- Controls starting, stopping, and monitoring of the spindle.
- Conducts a power-up sequence and calibrates the servo.
- Analyzes servo signals to provide closed loop control. These include position error signal and estimated velocity.
- Monitors the actuator position and determines the target track for a seek operation.
- Controls the voice coil motor driver to align the actuator in a desired position.
- Constantly monitors error conditions of the servo and takes corresponding action if an error occurs.
- Monitors various timers such as head settle and servo failure.
- Performs self-checkout (diagnostics).

### **3.2 Head Disk Assembly**

The head/disk assembly (HDA) is assembled in a clean room environment and contains disks, a spindle motor, actuator assembly, and voice coil motor. Air is constantly circulated and filtered when the drive is operational. Venting of the HDA is accomplished via a breather filter.

The spindle is driven directly by a brushless, sensorless DC drive motor. Dynamic braking is used to stop the spindle quickly.

### **3.3 Actuator**

The read/write heads are mounted in the actuator. The actuator is a swing-arm assembly driven by a voice coil motor. A closed-loop positioning servo controls the movement of the actuator. An embedded servo pattern supplies feedback to the positioning servo to keep the read/write heads centered over the desired track.

The actuator assembly is balanced to allow vertical or horizontal mounting without adjustment.

When the drive is powered off, the actuator automatically moves the head to the actuator ramp outside of the disk where it parks.



## 4.0 Drive Characteristics

### 4.1 Formatted Capacity

Table 2: Formatted Capacity

Description	Model Number	Model Number
Label capacity	2 TB	3 TB
Number of heads	7	10
Number of disks	4	5
Total data bytes (512 bytes/sector)	2,000,398,934,016	3,000,592,982,016
Total logical data blocks	3,907,029,168 (E8E088B0h)	5,860,533,168 (15D50A3B0h)

### 4.2 Data Sheet

Table 3: Data Sheet

Description	2TB Model	3TB Model
Max Data transfer rate (Mbps)	1618 (1777)	1666 (1830)
Interface transfer rate (MB/s)	600	
Data buffer size (MB)	64	
Number of buffer segments	1 - 254	
Rotational speed RPM	7200	
Recording density - Max (Kbpi)	1410 (1549)	1452 (1595)
Track density [KTPI] (average)	255	
Areal density - max (Gbits/in <sup>2</sup> )	360 (395)	370 (407)
Number of data bands	30	

XXX (XXX): New definition for Non-RS channel (Conventional definition)

## 4.3 Inquiry Information

### 4.3.1 Product ID

Product ID in Section 18.5.1, “Inquiry Data” on page 79, is as follows:

**Table 4: Product ID in Inquiry Command**

Product ID	Description
HUS723030ALS640	3 TB, SAS
HUS723030ALS641	3 TB, SAS
HUS723020ALS640	2 TB, SAS
HUS723020ALS641	2 TB, SAS

### 4.3.2 World Wide ID - Block Assignment

Block Assignment of World Wide ID is as follows:

**Table 5: Block assignment of World Wide ID in INQUIRY Command**

Manufacturing Site	Product	Block Assignment
Thailand	HUS723030ALS640 (YHSerialNumber3TB) HUS723030ALS641 – Common SATA/ SAS S/N’s  HUS723030ALS640 HUS723030ALS641	01Ah <sup>(1)</sup>
Thailand	HUS723020ALS640 (YHSerialNumber2TB) HUS723020ALS641 – Common SATA/ SAS S/N’s  HUS723020ALS640 HUS723020ALS641	01Bh <sup>(1)</sup>
Thailand	HUS723020ALS640 (YHSerialNumber2TB7 dn) HUS723020ALS641 – Common SATA/ SAS S/N’s  HUS723020ALS640 HUS723020ALS641	01Ch <sup>(1)</sup>

Note (1) - Additional block assignment will be issued as needed based on actual production volume.

## 4.4 Cylinder allocation

Physical cylinder is calculated from the starting data track of 0. It is not relevant to logical CHS. Depending on the capacity some of the inner zone cylinders are not allocated.



## 4.4.1 Data cylinder

This cylinder contains the user data which can be sent and retrieved via read/write commands and a spare area for reassigned data.

## 4.4.2 Spare cylinder

The spare cylinder is used by HGST, a Western Digital Company manufacturing and includes data sent from a defect location

# 4.5 Performance characteristics

Drive performance is characterized by the following parameters:

- Command overhead
- Mechanical head positioning
  - Seek time
  - Latency
- Data transfer speed
- Buffering operation (read ahead/write cache)

**Note:** All the above parameters contribute to drive performance. There are other parameters that contribute to the performance of the actual system. This specification tries to define the bare drive characteristics, not system throughput, which depends on the system and the application.

## 4.5.1 Mechanical positioning

### 4.5.1.1 Average seek time (including settling)

**Table 6: Mechanical positioning performance**

Command Type	Typical (ms)	Max (ms)
Read	7.6	7.9
Write	8.0	8.3

The terms “Typical” and “Max” are used throughout this specification with the following meanings:

**Typical.** The average of the drive population tested at nominal environmental and voltage conditions.

**Max.** The maximum value measured on any one drive over the full range of the environmental and voltage conditions. (See Section 6.2, “Environment” and Section 6.3, “DC Power Requirements”)

### 4.5.1.2 Full stroke seek time

Table 7: Full stroke seek time

Function	Typical (ms)	MAx (ms)
Read	14.5	15.5
Write	15.0	16.0

### 4.5.1.3 Average latency

Table 8: Latency time

Rotation	Time for a revolution (ms)	Average latency (ms)
7200 RPM	8.33	4.16

## 4.5.2 Drive ready time

Table 9: Drive ready time

Model	Typical (sec)	Maximum (sec)
5 Disk Model	< 20.0	< 30.0

**Ready** The condition in which the drive is able to perform a media access command (such as read, write) immediately.

**Power on** This includes the time required for the internal self diagnostics.

## 4.5.3 Operating Modes

### 4.5.3.1 Operating mode descriptions

Operating mode	Description
<b>Spin-up</b>	Start up time period from spindle stop or power down
<b>Seek</b>	Seek operation mode
<b>Write</b>	Write operation mode
<b>Read</b>	Read operation mode
<b>Unload Idle</b>	Spindle rotation at 7200 RPM with heads unloaded
<b>Idle</b>	Spindle motor and servo system are working normally. Commands can be received and processed immediately
<b>Standby</b>	Actuator is unloaded and spindle motor is stopped. Commands can be received immediately
<b>Sleep</b>	Actuator is unloaded and spindle motor is stopped. Only soft reset or hard reset can change the mode to standby

*Note: Upon power down or spindle stop a head locking mechanism will secure the heads in the OD parking position.*

### 4.5.3.2 Mode Transition times

**Table 10: Mode transition times**

From	To	RPM	Typical Transition time(sec)	Max Transition time(sec)
Standby	Idle	0 -> 7200	15	30
Idle	Standby	7200 -> 0	Immediately	Immediately
Standby	Sleep	0	Immediately	Immediately
Sleep	Standby	0	Immediately	Immediately
Unload idle	Idle	7,200	1	30
Idle	Unload idle	7,200	0.7	30
Low RPM Idle	Idle	4500 -> 7200	7	30

*Note: The command is processed immediately but there will be an actual spin down time reflecting the seconds passed until the spindle motor stops*

## 4.5.4 Data transfer speed:

**Table 11: Data transfer speed (sector size 512 Byte case)**

Description	Zone	Product	Typical (MB/Sec)	
			Read	Write
Disk-buffer transfer				
Instantaneous	0	MKS	179	179
Measured typical values for				
sustained disk-buffer transfer rate	0	MKS	164	164

Instantaneous	29	MKS	91	91
Measured typical values for				
sustained disk-buffer transfer rate	29	MKS	83	83

### Notes:

- Instantaneous disk-buffer transfer rate is derived by: (Number of sectors on a track) x 512 x (revolutions/sec)
- For this table, '1 MB / Sec' should be interpreted as 1,000,000 bytes per Second.
- The number of sectors per track varies in each zone (radius) as a result of constant linear density recording.
- Sustained disk-buffer transfer rate is the average rate measured while transferring multiple cylinders of data. It differs from the instantaneous transfer rate because of the time required to change tracks (Track skew and Head skew). In addition, time is added for the occasional missed track switch.

## 4.5.5 Buffering operation (read ahead/write cache)

This hard disk drive has a buffer for read ahead see 20.8, “Segmented Caching” on page 285.

## 5.0 Data Integrity

The drive retains recorded information under all non-write operations.

No more than one sector can be lost by power down during a write operation while write cache is disabled. If power down occurs before completion of a data transfer from write cache to disk while write cache is enabled, the data remaining in the write cache will be lost. To prevent this data loss at power off, the following action is recommended:

- Confirm successful completion of a SYNCHRONIZE CACHE (35h) command

## 5.1 Equipment Status

Equipment status is available to the host system any time the drive is not ready to READ, WRITE or SEEK. This status normally exists at power-on time and will be maintained until the following conditions are satisfied:

- Access recalibration/tuning is complete
- Spindle speed meets requirements for reliable operations
- Self-check of drive is complete

Appropriate error status is made available to the host system if any of the following conditions occur after the drive has become ready:

- Spindle speed goes outside of requirements for reliable operation
- “Write fault” is detected

## 5.2 Error Recovery Procedure

Errors occurring with the drive are handled by the error recovery procedure.

Errors that are uncorrectable after application of the error recovery procedures are reported to the host system as non-recoverable errors.



## 6.0 Physical Format

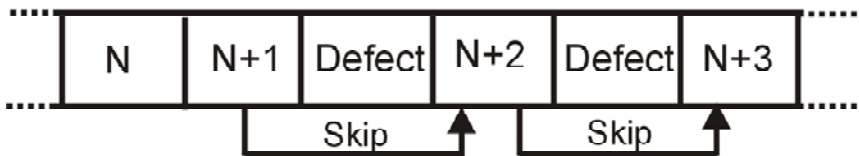
Media defects are remapped to the next available sector during the Format Process in manufacturing. The mapping from Logical Block Address (LBA) to the physical Block locations is calculated using internally maintained tables.

### 6.1 Shipped Format (P-List)

- Data areas are optimally used.
- All pushes generated by defects are absorbed by available tracks of the inner notch.

### P-List Physical Format

#### Plist physical format



**Note:** Defects are skipped without any constraint, such as track or cylinder boundary. The calculation from LBA to physical is done automatically by internal table.

### 6.2 Reassigned Format (G-List)

- G-List has a capacity of 22,000 Customer LBAs
- Multiple reassignments of the same Customer LBA increase the number of G-List entries.
- A track for spare sectors is inserted after every 800 nominal customer tracks.





# 7.0 Electrical Interface

## 7.1 SAS Connector

The drive uses the standard 29 pin Serial Attached SCSI (SAS) connector which conforms to the mechanical requirements of SFF 8482. The connector is expected to be used in an environment which uses a common connector structure for racking disk drives in a cabinet. The connector allows for plugging a drive directly into a backplane by providing the necessary electrical connection. Mechanical stability and device retention must be provided by a mechanism outside the drive.

### 7.1.1 29 pin Serial Attached SCSI (SAS) Connector Definition

Diagram of top and bottom of connector showing pinouts.

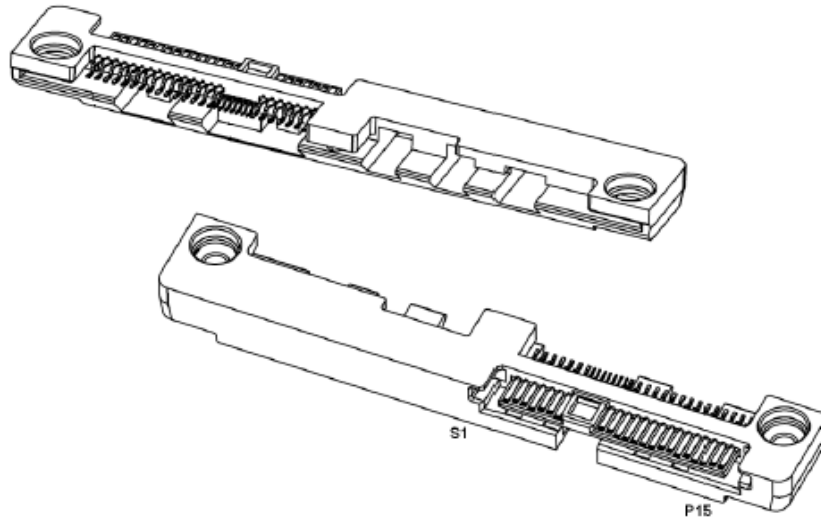


Table 12: 29-pin Connector Signal Definition

Pin Number	Signal	Description
S1	GND	GND for SAS Primary Port
S2	RP+	SAS Primary Port Receive (positive) signal
S3	RP-	SAS Primary Port Receive (negative) signal
S4	GND	GND for SAS Primary Port
S5	TP-	SAS Primary Port Transmit (negative) signal
S6	TP+	SAS Primary Port Transmit (positive) signal
S7	GND	GND for SAS Primary Port
S8	GND	GND for SAS Secondary Port

Pin Number	Signal	Description
S9	RS+	SAS Secondary Port Receive (Positive) signal
S10	RS-	SAS Secondary Port Receive (negative) signal
S11	GND	GND for SAS Secondary Port
S12	TS-	SAS Secondary Port Receive (negative) signal
S13	TS+	SAS Secondary Port Receive (positive) signal
S14	GND	GND for SAS Secondary Port
P1	+3.3V	NOT USED (Pins P1-P3 tied internally)
P2	+3.3V	NOT USED (Pins P1-P3 tied internally)
P3	+3.3V	NOT USED (Pins P1-P3 tied internally)
P4	GND	GROUND
P5	GND	GROUND
P6	GND	GROUND
P7	+5V-Charge	Pre-charge pin for +5V
P8	+5V	+5V power supply input
P9	+5V	+5V power supply input
P10	GND	GROUND
P11	READY LED	READY LED output
P12	GND	GROUND
P13	+12V=Charge	Pre-charge pin for +12V
P14	+12V	+12V power supply input
P15	+12V	+12V power supply input

### 7.1.2 Voltage and Ground Signals

The 12V and 5V contacts provide all of the voltages required by the drive. The two voltages share a common ground plane to which all of the ground contacts are connected.

### 7.1.3 Ready LED output

The drive provides an open-drain driver with 15mA of current sink capability to the Ready LED Output signal. The cathode of the LED should be connected to this signal. The LED and the current-limiting resistor must be provided by the enclosure

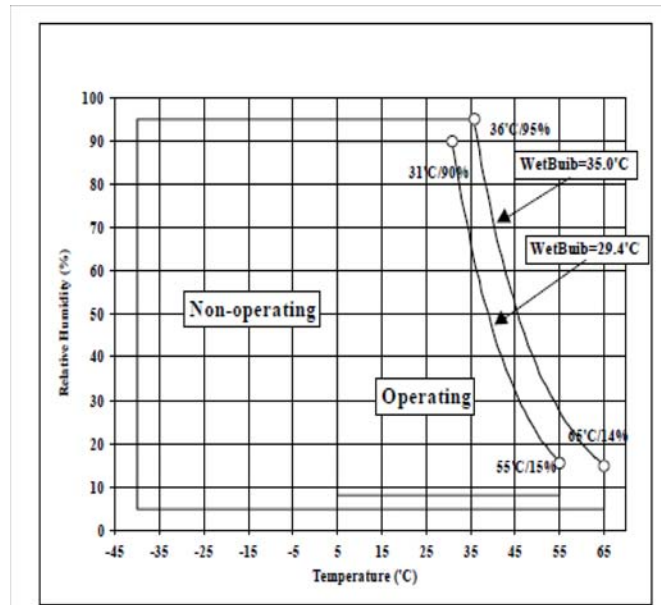
# 8.0 Environment

## 8.1 Temperature and humidity

Table 13: Operating and non-operating conditions

<b>Operating conditions</b>	
Ambient Temperature	5°C to 60°C
Relative humidity	5 to 90%, non-condensing
Maximum wet bulb temperature	29.4°C, non-condensing
Maximum surface temperature gradient	20°C/hour
Altitude	-305 to 3,048 m
<b>Shipping conditions</b>	
Ambient Temperature	-40°C to 70°C
Relative humidity	5 to 95%, non-condensing
Maximum wet bulb temperature	35°C, non-condensing
Maximum surface temperature gradient	30°C/hour
Altitude	-305 to 12,192 m
<b>Storage conditions</b>	
Ambient Temperature	-40°C to 70°C
Relative humidity	5 to 90%, non-condensing
Maximum wet bulb temperature	35°C, non-condensing
Altitude	-305 to 12,192 m

Environments that contain elevated levels of corrosives (e.g. hydrogen sulfide, sulfur oxides, or hydrochloric acid) should be avoided. Care must be taken to avoid using any compound/material in a way that creates an elevated level of corrosive materials in the atmosphere surrounding the disk drive. Care must also be taken to avoid use of any organometallic (e.g. organosilicon or organotin) compound/material in a way that creates elevated vapor levels of these compounds/materials in the atmosphere surrounding the disk drive.



## 8.2 Storage requirements

### 8.2.1 Packaging

The drive or option kit must be heat-sealed in a moisture barrier bag with desiccant inside the bag supplied by HGST, a Western Digital Company.

### 8.2.2 Storage time

Cumulative storage time in the package must not exceed one year. If a longer storage time is required, the drive must be repackaged with new desiccant or moved to a climatically controlled environment.

After the drive is unpackaged, it must not remain inoperative for longer than six months.

## 8.3 Corrosion test

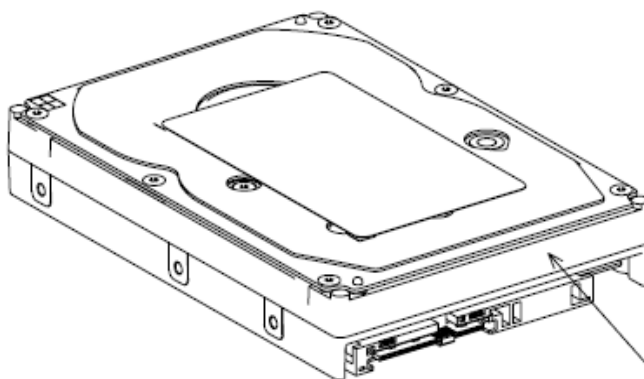
The hard disk drive shows no signs of corrosion inside or outside of the hard disk assembly and remains functional after being exposed to a temperature of 50°C and relative humidity of 90% for seven days

## 8.4 Cooling requirements

Drive component surface temperatures must remain within the limits specified in the following table. The drive may require forced air cooling to meet specified operating temperatures.

**Table 14: Maximum allowable surface temperatures**

Module name	Location	Maximum allowable surface temperature
HDD base casting	as noted in picture	60°C



Recommended Temperature Measurement Location



## 9.0 DC Power Requirements

The following voltage specification applies at the drive power connector. Connections to the drive should be made in a safety extra low voltage (SELV) circuit. There is no power on or power off sequencing requirement.

Adequate secondary over-current protection is the responsibility of the system.

**Table 15: Input Voltage and capacitance**

	<b>Tolerance</b>	<b>Absolute Max Spike Voltage</b>	<b>Supply Rise Time</b>	<b>Capacitance</b>
+5 Volts Supply	+/- 5%	5.5 V	0-200 ms	53 uF
+12 Volts Supply	+/- 5%	15 V	0-400 ms	26 uF

**Note:** -8% is acceptable during spin up, but the spin up time is not guaranteed.

# 9.1 Power Supply Current, Average and Peak

The following current and power requirements are typical when operating under the following conditions: Nominal 5 and 12V, Background Media Scan (BMS) disabled for Idle, Write Caching disabled and the drive reporting a temperature of 40C.



Model: SAS 7200 LFF @ 6Gb/sec		2TB Model		Power Watts			
IO /Sec	Current +5V Amp	Current +12V Amp					
Spin Up Peak DC [1]		1.39					
Spin Up Peak AC		0.54	1.80				
Active Idle , Avg		0.39	0.40	6.8			
Idle Ripple [2]		0.08	0.29				
Random RW 4KB Qd=4 Peak		0.68	1.86				
Random RW 4KB Qd=4 Avg	108	0.41	0.61	9.4			
Random RW 4KB Qd=1 Avg	82	0.40	0.62	9.4			
Sequential Read Peak		0.75					
Sequential Read Average [3]		0.65	0.40	8.1			
Sequential Write Peak		0.70					
Sequential Write Average [3]		0.60	0.43	8.2			
BMS Peak		0.69					
BMS Average		0.57	0.39	7.6			
<b>Power Save Modes</b>							
	Current +5V Amp	+12V Amp	Power Watts	Watts, Saved	Recovery [1] 12V DC peak	12V AC peak	Time in Seconds Typical
Idle_A	0.39	0.40	6.8	0.0			0.0
Idle_B	0.30	0.33	5.5	1.3			0.3
Idle_C	0.30	0.25	4.5	2.3	0.85	1.17	3
Standby_Y	0.30	0.25	4.5	2.3	0.85	1.17	3
Standby_Z	0.30	0.02	1.7	5.0	1.38	1.80	11
<b>Notes</b>							
[1] 200mS windowed average							
[2] Pk to Pk BWL @ 20Mhz							
[3] Max transfer rate							



Model: SAS 7200 LFF @ 6Gb/sec		3TB Model							
	IO /Sec	Current +5V Amp	Current +12V Amp	Power Watts					
Spin Up Peak DC [1]			1.40						
Spin Up Peak AC		0.56	1.81						
Active Idle , Avg		0.37	0.48	7.6					
Idle Ripple [2]		0.08	0.28						
Random RW 4KB Qd=4 Peak		0.71	1.92						
Random RW 4KB Qd=4 Avg	107	0.39	0.70	10.4					
Random RW 4KB Qd=1 Avg	81	0.38	0.71	10.4					
Sequential Read Peak		0.77							
Sequential Read Average [3]		0.63	0.48	8.9					
Sequential Write Peak		0.71							
Sequential Write Average [3]		0.58	0.52	9.1					
BMS Peak		0.70							
BMS Average		0.55	0.48	8.5					
Power Save Modes		Current		Power		Recovery [1]		Time in Seconds	
		+5V Amp	+12V Amp	Watts	Watts, Saved	12V DC peak	12V AC peak	Typical	
Idle_A		0.37	0.48	7.6	0.0			0.0	
Idle_B		0.29	0.39	6.1	1.5			0.3	
Idle_C		0.29	0.30	5.1	2.6	0.87	1.21	4	
Standby_Y		0.29	0.30	5.1	2.6	0.87	1.21	4	
Standby_Z		0.28	0.03	1.8	5.9	1.40	1.88	13	
Notes									
[1] 200mS windowed average									
[2] Pk to Pk BWL @ 20Mhz									
[3] Max transfer rate									

## 9.2 Ripple Voltage

Table 16: Power Supply Generated Ripple at Drive Power Connector

	Maximum (mV pp)	MHz
+5 V DC	250	0-10
+12 V DC	250	0-10

During drive start up and seek, 12 volt ripple is generated by the drive (referred to as dynamic loading). If the power of several drives is daisy chained, the power supply ripple plus other drive dynamic loading must remain within the regulation tolerance of +5%. A common supply with separate power leads to each drive is a more desirable method of power distribution.

To prevent external electrical noise from interfering with the drive's performance, the drive must be held by four screws in a user system frame that has no electrical level difference at the four screw positions. The drive enclosure must not be used in the current return path of the drive power supply. The maximum common-mode noise current passing through the drive must not exceed 20 mA.

# 9.3 Power Consumption Efficiency Index

Table 17: Power Consumption Efficiency Index

Model	2 TB Model	3 TB Model
Power Consumption Efficiency Index -Idle Mode (W/GB)	0.0034	0.0025

## 10.0 Reliability

### 10.1 Start/Stop Cycles

The drive is designed to withstand a minimum of 50,000 start/stop cycles at ambient environment.

The drive is designed to withstand a minimum of 10,000 start/stop cycles at the operating environment conditions specified in Chapter 8.0, “Environment” on page 19.

### 10.2 Load/Unload Cycles

The drive is designed to withstand a minimum of 600,000 load/unload cycles at the operating environmental conditions specified in Chapter 8.0, “Environment” on page 19

### 10.3 Data Reliability

The probability of an uncorrectable data error is 1 in  $10^{15}$  bits read.

ECC implementation:

- 1 symbol = 10 bits
- 1 interleaves
- 16 symbols, On-The-Fly correction
- Up to 30 symbols (total) Off-Line correction with burst error information
- LBA seeded 32 bit CRC for ECC miscorrect detection

### 10.4 Seek errors

A non-recoverable seek/ID miscompare error is defined as a seek operation that cannot be recovered by the error recovery procedure of the drive. The drive reports sense key 04 and sense code 02 for this error.

No drive has more than one non-recoverable seek/ID miscompare error per 100 million seek operations (1 in  $1 \times 10^8$ ) when operated at the full range of voltage and environmental conditions.

### 10.5 Failure prediction (S.M.A.R.T)

A recoverable equipment error is an error other than a seek/ID miscompare error or read error that is detected and corrected by the drive error recovery procedure. Examples are *Write Fault*, *Drive Not Ready* and internal drive errors.

SMART Monitoring Parameters are checked to determine if the (Read/Write/Seek) error rates exceed the drive’s threshold value when an error occurs and a minimum amount of operation has been completed. A check is also performed for a minimum level of Spare Sector Availability.

The Head Load / Unload Count, Spin Up Time and Spin Up Retry Count parameters are checked prior to reporting a “Ready” condition at Power On.

Non-recoverable equipment errors indicate a defective drive.

### 10.6 MTBF (Mean Time Between Failure): 2.0 M hours.

This MTBF target is based on a sample population and is estimated by statistical measurements and acceleration algorithms under nominal operating conditions. MTBF ratings are not intended to predict an individual drive’s reliability. MTBF does not constitute a warranty.

## 10.7 Preventive Maintenance

None.

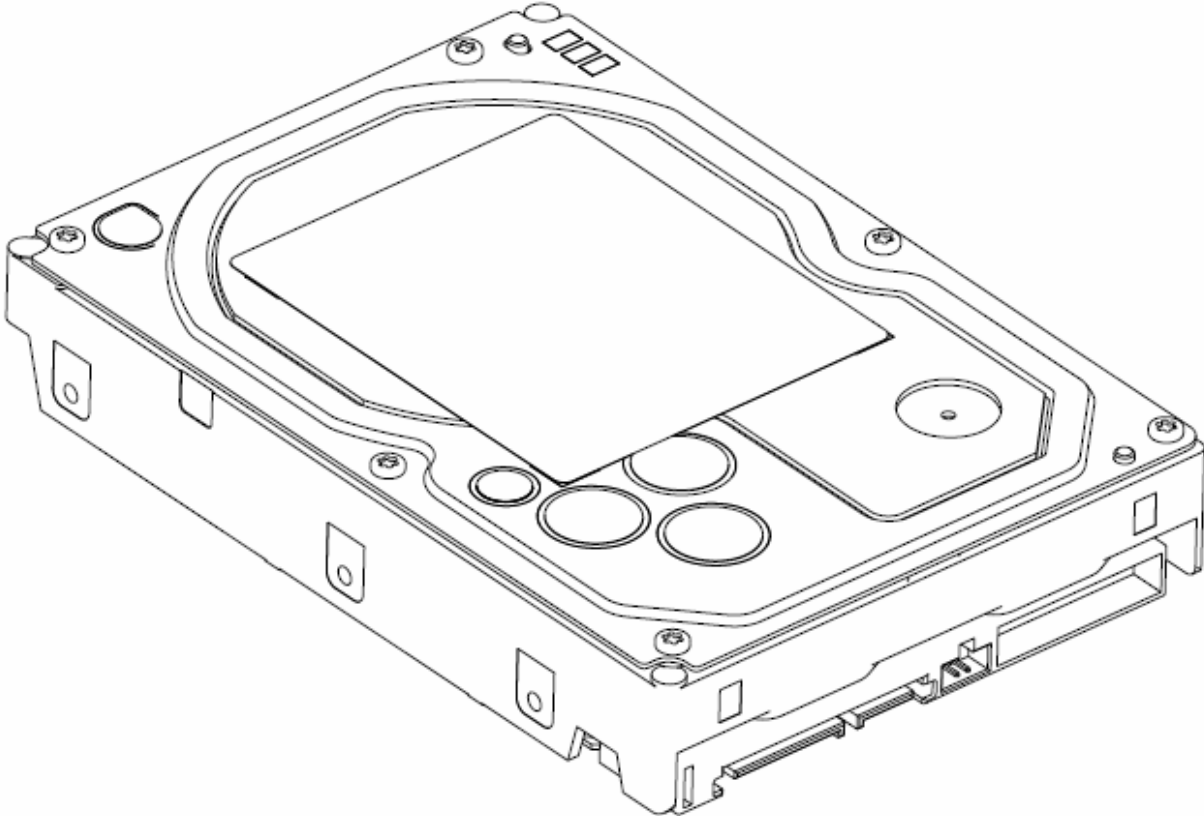
## 10.8 Temperature Warning

Temperature Warning is enabled by setting the EWASC (Enable Warning Additional Sense Code) bit to 1 and setting DEX-CPT (Disable Exception Control) bit to 0 in Mode Page 1C. For mode page settings, refer to Section 18.10.14, “.Mode Page 1C (Informational Exceptions Control)” on page 167. The warning is issued as sense data (Sense Key 01h, Code 0Bh, Qual 01h).

The drive temperature is reported in Log Sense page 2F. Refer to Section 18.7.12, “Log Sense Page 18” on page 118.

# 11.0 Mechanical Specifications

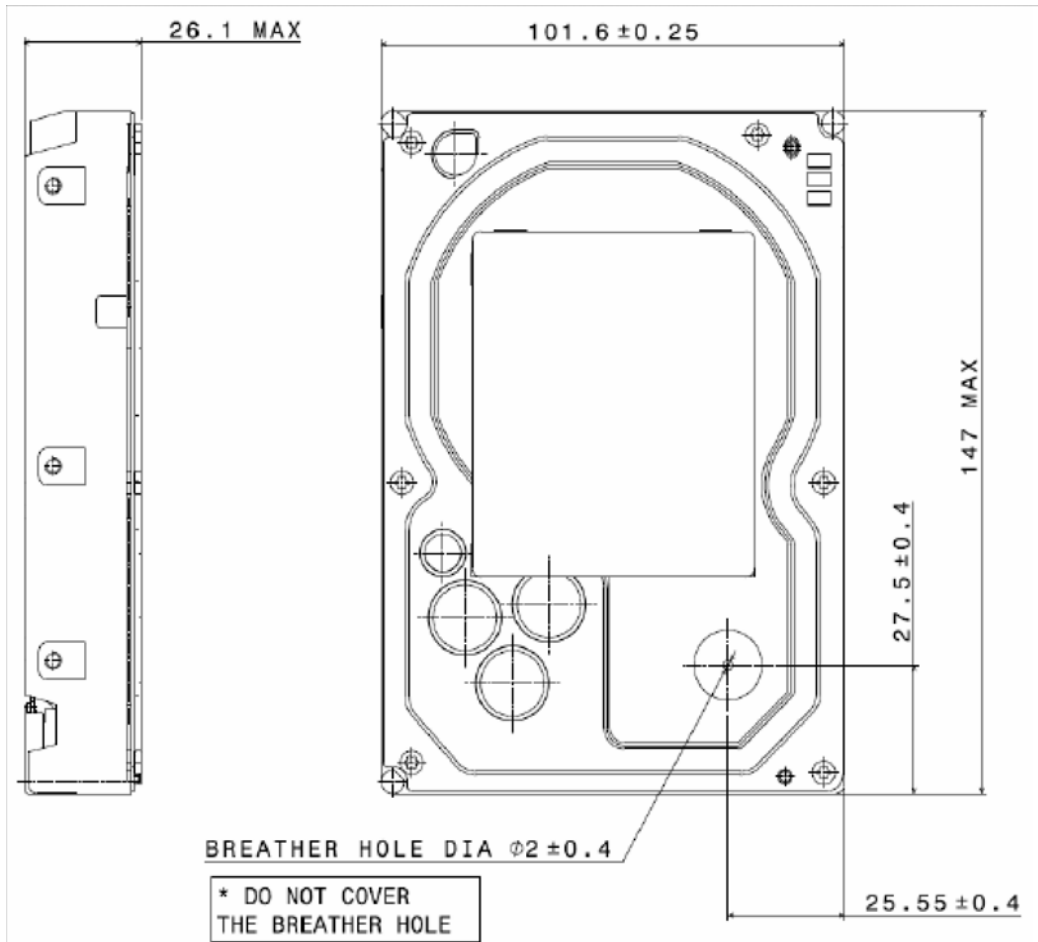
## 11.1 Outline

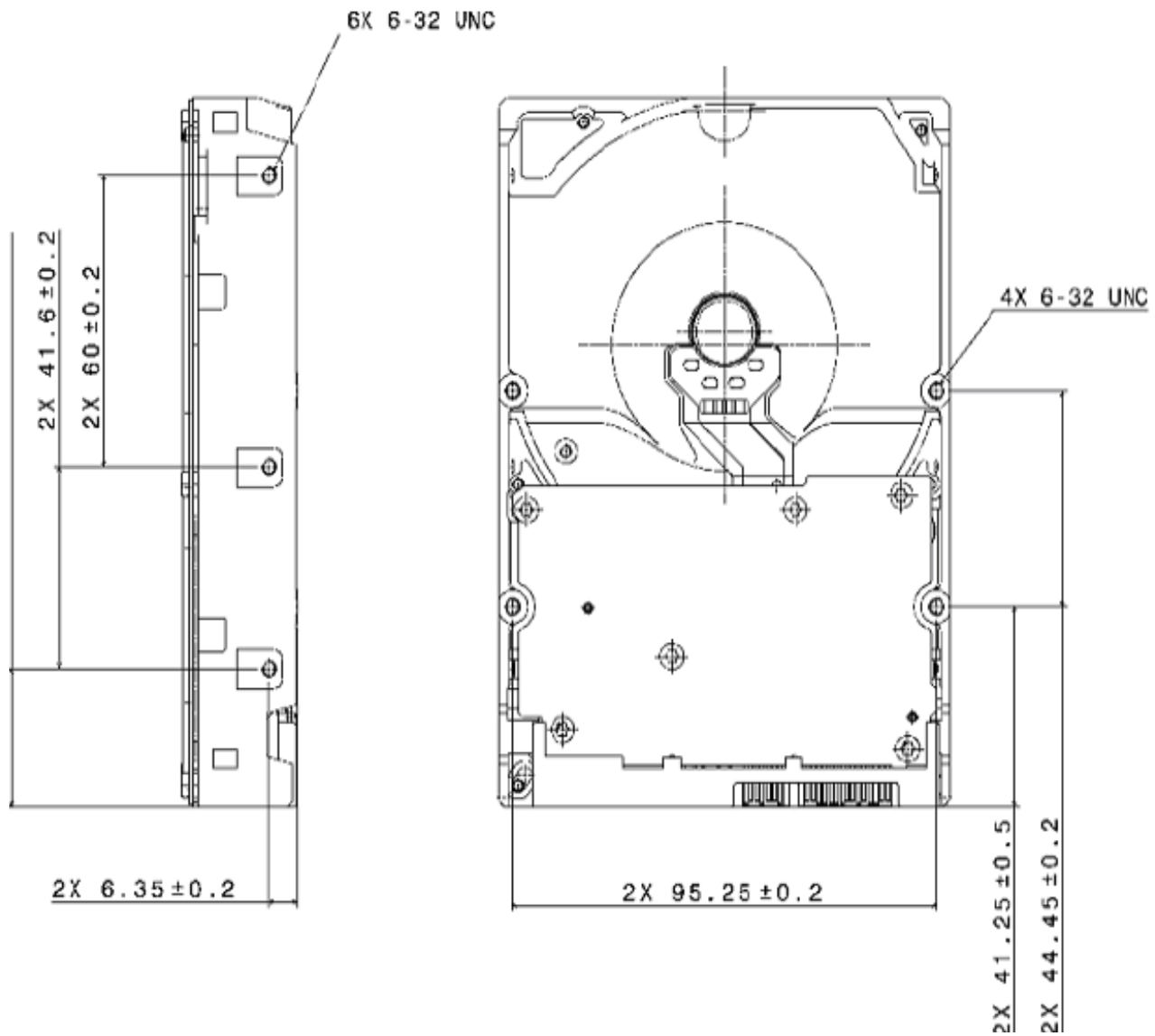


S

## 11.2 Mechanical Dimensions

The drive complies with SFF-8301.

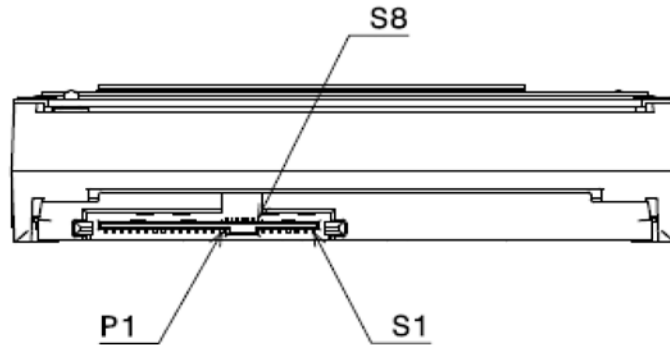




**Table 18: Physical Dimensions**

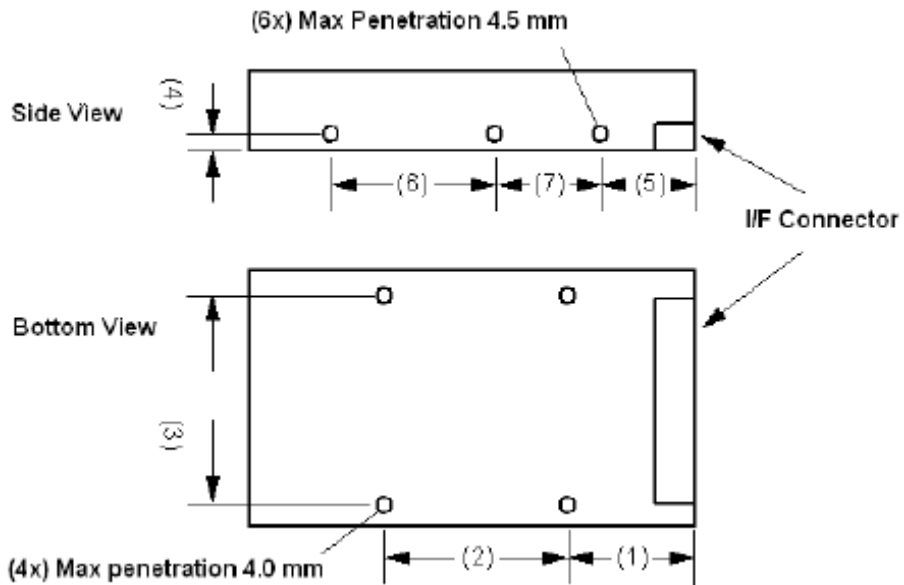
Height [mm]	26.1 MAX
Width [mm]	$101.6 \pm 0.25$
Length [mm]	147 MAX
Weight [grams - maximum]	690 grams

### 11.3 Interface Connector



### 11.4 Mounting Positions and Tappings

The mounting hole location and size for the hard disk drive is shown below.



Thread	(1)	(2)	(3)	(4)	(5)	(6)	(7)
6-32UNC	41.28±0.5	44.45±0.2	95.25±0.2	6.35±0.2	28.5±0.5	60.0±0.2	41.6±0.2



## 11.5 Drive Mounting

The drive will operate in all axes (6 directions). Performance and error rate will stay within specification limits if the drive is operated in the other orientations from which it was formatted.

The recommended mounting screw torque is 0.6 - 1.0 Nm (6 - 10 kgf-cm). The recommended mounting screw depth is 4 mm maximum for bottom and 4.5 mm maximum for horizontal mounting.

To avoid performance degradation, mount the drive in the system securely enough to prevent excessive motion or vibration of the drive at seek operation or spindle rotation, using appropriate screws or equivalent mounting hardware. Consult with the issuer of this specification for actual application if necessary.

Drive level vibration tests and shock tests are to be conducted with the drive mounted to a table using the bottom four screws.

## 11.6 Heads Unload and Actuator Lock

Heads are moved out from the disks (unload) to protect the disk data during shipping, moving or storage. At power down, the heads are automatically unloaded from over the disk area and the head actuator locking mechanism will secure the heads in the unload position.



## 12.0 Vibration and Shock

All vibration and shock measurements recorded in this section are made with a drive that has no mounting attachments for the systems. The input power for the measurements is applied to the normal drive mounting points.

### 12.1 Operating vibration

#### 12.1.1 Random vibration (Linear)

The test is 30 minutes of random vibration using the power spectral density (PSD) levels shown below in each of three mutually perpendicular axes. The disk drive will operate without non-recoverable errors when subjected to the below random vibration levels.

**Table 19: Random vibration PSD profile break points (operating)**

Frequency	5 Hz	17 Hz	45 Hz	48 Hz	62 Hz	65 Hz	150 Hz	200 Hz	500 Hz	RMS (m/sec <sup>2</sup> )
[(m/sec <sup>2</sup> ) <sup>2</sup> /Hz]	1.9 x 10E-3	1.1 x 10E-1	1.1 x 10E-1	7.7 x 10E-1	7.7 x 10E-1	9.6 x 10E-2	9.6 x 10E-2	4.8 x 10E-2	4.8 x 10E-2	6.57

The overall RMS (root mean square) level is 6.57 m/sec<sup>2</sup> (0.67 G).

#### 12.1.2 Swept sine vibration (Linear)

The drive will meet the criteria shown below while operating in the specified conditions:

- No errors occur with 4.9 m/sec<sup>2</sup> (0.5 G) 0 to peak, 5 to 300 to 5 Hz sine wave, 0.5 oct/min sweep rate with 3-minute dwells at two major resonances
- No data loss occurs with 9.8 m/sec<sup>2</sup> (1 G) 0 to peak, 5 to 300 to 5 Hz sine wave, 0.5 oct/min sweep rate with 3-minute dwells at two major resonances

#### 12.1.3 Random vibration (Rotational)

The drive will meet the criteria shown below while operating in the specified conditions:

- Less than 20% Performance degradation
- The overall RMS (Root Mean Square) level of vibration is 12.5Rad/sec<sup>2</sup>. PSD profile is shown below.
- 

**Table 20: Random vibration (Rotational) PSD profile break points (TBD)**

Frequency	20 Hz	100 Hz	200 Hz	800 Hz	1000 Hz	1500 Hz	RMS (Rad/s <sup>2</sup> )
[(Rad/s <sup>2</sup> ) <sup>2</sup> / Hz]							12.5

## 12.2 Nonoperating vibration

The drive does not sustain permanent damage or loss of previously recorded data after being subjected to the environment described below

### 12.2.1 Random vibration

The test consists of a random vibration applied for each of three mutually perpendicular axes with the time duration of 10 minutes per axis. The PSD levels for the test simulate the shipping and relocation environment shown below. The overall RMS (Root Mean Square) level of vibration is 10.2 m/sec<sup>2</sup> (1.04 G).

**Table 21: Random vibration PSD profile break points (non operating)**

Frequency	2 Hz	4 Hz	8 Hz	40 Hz	55 Hz	70 Hz	200 Hz
[(m/sec <sup>2</sup> ) <sup>2</sup> /Hz]	0.096	2.89	2.89	0.289	0.962	0.962	0.096

### 12.2.2 Swept sine vibration

- 19.6 m/sec<sup>2</sup> (2 G) (Zero to peak), 5 to 500 to 5 Hz sine wave
- 0.5 oct/min sweep rate
- 3 minutes dwell at two major resonances

## 12.3 Operating shock

The drive meets the following criteria while operating in the conditions described below. The shock test consists of 10 shock inputs in each axis and direction for total of 60. There must be a delay between shock pulses long enough to allow the drive to complete all necessary error recovery procedures.

- No error occurs with a 98.1 m/sec<sup>2</sup> (10 G) half-sine shock pulse of 11 ms duration
- No data loss occurs with a 294 m/sec<sup>2</sup> (30 G) half-sine shock pulse of 4 ms duration.
- No data loss occurs with a 686 m/sec<sup>2</sup> (70 G) half-sine shock pulse of 2 ms duration.

## 12.4 Nonoperating shock

The drive will operate without non-recoverable errors after being subjected to shock pulses with the following characteristics.

### 12.4.1 Trapezoidal shock wave

- Approximate square (trapezoidal) pulse shape
- Approximate rise and fall time of pulse is 1 ms
- Average acceleration level is 490 m/sec<sup>2</sup> (50 G). (Average response curve value during the time following the 1 ms rise time and before the 1 ms fall with a time "duration of 11 ms")
- Minimum velocity change is 4.23 m/sec

### 12.4.2 Sinusoidal shock wave

The shape is approximately half-sine pulse. The figure below shows the maximum acceleration level and duration.

**Table 22: Sinusoidal shock wave**

Acceleration level (m/sec <sup>2</sup> )	Duration (ms)
2940 (300G)	1
1470 (150G)	11

## 12.5 Nonoperating Rotational shock

All shock inputs shall be applied around the actuator pivot axis.

**Table 23: Sinusoidal shock wave**

<b>Duration</b>	<b>Rad/Sec<sup>2</sup></b>
1 ms	30,000
2 ms	20,000

All vibration and shock measurements in this section are made with a bare drive. The input for the measurements are applied to the normal drive mounting points unless noted otherwise.



## 13.0 Acoustics

The upper limit criteria of the octave sound power levels are given in Bels relative to one picowatt and are shown in the following table. The sound power emission levels are measured in accordance with ISO 7779.

**Table 24: Sound power levels**

Mode	7200rpm (Typical / Max)
Idle	2.9 / 3.4
Operating Seek Mode	3.2 / 3.6

**Mode definition:**

**Idle mode.** The drive is powered on, disks spinning, track following, unit ready to receive and respond to interface commands.

**Operating mode.** Continuous random cylinder selection and seek operation of the actuator with a dwell time at each cylinder. The seek rate for the drive is to be calculated as shown below:

- Dwell time =  $0.5 \times 60/\text{RPM}$
- Seek rate =  $0.4 / (\text{Average seek time} + \text{Dwell time})$ A-weighted sound power levels





# 14.0 Identification

## 14.1 Labels

The following labels are affixed to every hard disk drive shipped from the drive manufacturing location in accordance with appropriate hard disk drive assembly drawing:

- A label containing HGST, a Western Digital Company logo, HGST part number and the statement “Made by HGST,” or HGST approved equivalent.
- A label containing drive model number, manufacturing date, formatted capacity, country of origin or HGST approved equivalent and UL, C-UL, TUV, CE, MIC, BSMI, CTICK, RoHS and Recycle logos.
- A bar code label containing the drive serial number.
- A user designed label, per agreement
- Interface definition mark, SAS-3 Model

The labels may be integrated with other labels.



**HGST** [www.hgst.com](http://www.hgst.com)  
 MADE IN THAILAND  
 BY HGST (THAILAND) LTD



KCC-REM-HG2-HUS723020ALS64 (B)  
 WARRANTY VOID IF ANY LABEL/  
 SCREW IS REMOVED OR BROKEN

MODEL: HUS723020ALS640	LES
SAS	DC
RATED: 5V 0.7A. 12V 0.8A	
CAPACITY: 2 TB	RPM: 7200RPM
P/N : 0B26312	F/W: A222

**HGST** [www.hgst.com](http://www.hgst.com)  
 MADE IN THAILAND  
 BY HGST (THAILAND) LTD



KCC-REM-HG2-HUS723020ALS64 (B)  
 WARRANTY VOID IF ANY LABEL/  
 SCREW IS REMOVED OR BROKEN

MODEL: HUS723020ALS641	LES
SAS	DC
RATED: 5V 0.7A. 12V 0.8A	
CAPACITY: 2 TB	RPM: 7200RPM
P/N : 0B26314	F/W: A222

**HGST** [www.hgst.com](http://www.hgst.com)  
 MADE IN THAILAND  
 BY HGST (THAILAND) LTD



KCC-REM-HG2-HUS723030ALS64 (B)  
 WARRANTY VOID IF ANY LABEL/  
 SCREW IS REMOVED OR BROKEN

MODEL: HUS723030ALS641	LES
SAS	DC
RATED: 5V 0.7A. 12V 0.8A	
CAPACITY: 3 TB	RPM: 7200RPM
P/N : 0B26313	F/W: A222

# 15.0 Electromagnetic Compatibility

The drive, when installed in a suitable enclosure and exercised with a random accessing routine at a maximum data rate will comply with the worldwide EMC requirements listed below.

The drive is designed for system integration and installation into a suitable enclosure for use. As such, the drive is supplied as a subassembly and is not subject to Subpart B of Part 15 of the FCC Rules and Regulations.

The design of the drive serves to minimize radiated emissions when installed in an enclosure that provides reasonable shielding. As such, the drive is capable of meeting FCC Class B limits. However, it is the users responsibility to assure that the drive meets the appropriate EMC requirements in their system. Shielded I/O cables may be required if the enclosure does not provide adequate shielding, with the shields grounded to the enclosure and to the host computer.

## Radiated and Conducted EMI

CISPR22	Class B
AS/NZS CISPR22	Class B
CNS13438 (Taiwan)	Class B
EN55022 (EU)	Class B
FCC Title47 Part 15 (USA)	Class B
GB9254 (China)	Class B
ICES-003, Issue 4	Class B
VCCI (Japan)	Class B

## ITE Immunity

EN55024

## Power Line Harmonics

EN61000-3-2 (EU)

GB17625.1 (China)

## Voltage Fluctuations and Flicker

EN61000-3-3 (EU)

GB17625.2 (China)

## 15.1 Class B Regulatory Notices

### European Union

This product is in conformity with the protection requirements of EU Council Directive 2004/108/EC on the approximation of the laws of the Member States relating to electromagnetic compatibility. HGST cannot accept responsibility for any failure to satisfy the protection requirements resulting from a non-recommended modification of the product, including the fitting of non-HGST option cards.

This product has been tested and found to comply with the limits for Class B Information Technology Equipment according to European Standard EN 55022. The limits for Class B equipment were derived for typical residential environments to provide

reasonable protection against interference with licensed communication devices.

### Canada

This Class B digital apparatus complies with Canadian ICES-003.

Cet appareil numérique de la classe B est conforme à la norme NMB-003 du Canada.

### Germany

Deutschsprachiger EU Hinweis:

Hinweis für Geräte der Klasse B EU-Richtlinie zur Elektromagnetischen Verträglichkeit Dieses Produkt entspricht den Schutzanforderungen der EU-Richtlinie 89/336/EWG zur Angleichung der Rechtsvorschriften über die elektromagnetische Verträglichkeit in den EU-Mitgliedsstaaten. und hält die Grenzwerte der EN 55022 Klasse B ein. Um dieses sicherzustellen, sind die Geräte wie in den Handbüchern beschrieben zu installieren und zu betreiben. Des Weiteren dürfen auch nur von der HGST empfohlene Kabel angeschlossen werden. HGST übernimmt keine Verantwortung für die Einhaltung der Schutzanforderungen, wenn das Produkt ohne Zustimmung der HGST verändert bzw. wenn Erweiterungskomponenten von Fremdherstellern ohne Empfehlung der HGST gesteckt/eingebaut werden.

**Deutschland:** Einhaltung des Gesetzes über die elektromagnetische Verträglichkeit von Geräten

Dieses Produkt entspricht dem "Gesetz über die elektromagnetische Verträglichkeit von Geräten (EMVG)". Dies ist die Umsetzung der EU-Richtlinie 89/336/EWG in der Bundesrepublik Deutschland.

Zulassungsbescheinigung laut dem Deutschen Gesetz über die elektromagnetische Verträglichkeit von Geräten (EMVG) vom 18. September 1998 (bzw. der EMC EG Richtlinie 89/336) für Geräte der Klasse B Dieses Gerät ist berechtigt, in Übereinstimmung mit dem Deutschen EMVG das EG-Konformitätszeichen - CE - zu führen. Verantwortlich für die Konformitätserklärung nach Paragraf 5 des EMVG ist die HGST, a Western Digital Company, 3403 Yerba Buena Road San Jose, CA 95135. Informationen in Hinsicht EMVG Paragraf 4 Abs. (1) 4:

Das Gerät erfüllt die Schutzanforderungen nach EN 55024 und EN 55022 Klasse B.

### Korea (MIC)

이 기기는 가정용으로 전자파적합등록을 한 기기로서 주거 지역에서는 물론 모든 지역에서 사용할 수 있습니다.

### Taiwan (BSMI)

新加坡商日立環球儲存科技股份有限公司台灣分公司  
台北市敦化北路167號5樓(宏國大樓)

## 16.0 Safety Standards

The following shows the safety standards for different countries.

### 16.1 UL and C-UL Standard Conformity

This drive is used as a component in Information Technology Equipment (ITE) business equipment systems. This drive is certified for use in the United States per UL 60950-1, Second Edition, 2007-03-27 and in Canada per CSA C22.2 No. 60950-1-07, Second Edition, 2007-03. The cRUus UL component recognition mark is specifically used on component parts that are part of a larger product or system and indicates compliance with both Canadian and U.S. requirements. The recognition mark appears on the drive label and is maintained for the life of the product.

### 16.2 European Standards Compliance

The product is additionally certified to the following standard:

International Electrotechnical Commission (IEC) Safety Standard:

IEC 60950-1:2005, Second Edition (IECEE CB Scheme)

### 16.3 German Safety Mark

This product has received the TUV Bauart Certification mark under EN 60950-1:2006 with Am. 11 (2009), Second Edition safety standard. The GS mark is not applicable to internal subsystem drives.

### 16.4 Flammability

The printed wiring boards, flex cables, and connectors used in this drive meet or exceed the UL minimum flammability classifications listed in the table below.

The flammability rating is marked or etched on the board.

Component	Flammability Rating
Rigid Printed Wiring Board	Min. V-1
Flex Cable - no components	Min. V-2
Flex Cable with components	Min. V-1
Interface & motor connectors	Min. V-2

### 16.5 Corporate Standards Compliance

This product has been designed to meet the following Corporate Standards:

- NB 3-0501-201 Product Safety, National Requirements-All Countries.
- CS 3-0501-070 Electrical, Mechanical and Flammability
- NB 3-0501-033 Product Safety National Certification Conformity Requirement
- CS 1-9700-020 Eco-Product Design Requirement



# 17.0 SAS Attachment

This section defines some basic terminology and describes the behavior of the drive when attached to a **Serial Attached Scsi** (i.e. SAS) domain.

## 17.1 General

This section introduces some of the terminology that is used in describing **Serial Attached SCSI** (i.e. SAS).

SAS is logically a bi-directional, point to point serial data channel that leverages the Scsi protocol set. Nodes are physically connected via a Port.

Ports may be connected point-to-point via SAS expanders, to form a complex switching network, referred to as a SAS domain.

SAS is defined in terms of a hierarchy of functions or 'protocol layers'. This discussion will focus in on the aspects of SAS that are relevant to this product.

- SCSI Application Layer - Clause 10
- SSP Transport Layer (**S**erial **S**CSI **P**rotocol) - Clause 9
- SAS Port Layer - Clause 8
- SSP Link Layer - Clause 7
- SAS PHY Layer - Clause 6
- SAS Physical Layer - Clause 5

All layers are defined in the following ANSI standard.

- "Serial Attached SCSI - 2 (SAS-2)"

In addition, this drive claims compliance with the following ANSI standards.

- SCSI Architecture Model (SAM-3)
- SCSI Block Commands (SBC2)

## 17.2 SAS Features

The following SAS features are supported by the Drive.

- SAS Compliance
  - "Serial Attached SCSI - 2 (SAS-2)"
- SAS Protocol
  - This drive supports **S**erial **S**csi **P**rotocol (SSP).
  - STP (Tunneled SATA) and SMP (Management protocol) protocols are NOT supported.
- SAS Dual Ported Operation
  - single PHY ports (i.e. Narrow port. Wide Port NOT supported)
  - ports function independently with separate firmware controls
  - Multiple DMA engines capable of accessing either port
  - full duplex and dual port DMA data/data operations
  - Maximum outstanding credit of *four* per port



- Physical Link Rates
  - G1 (1.5 Gbps), G2 (3.0 Gbps), and G3 (6.0 Gbps) supported
  - Largely Automated OOB and speed negotiation sequences
  - Optional Support for the hot-plug timeout in hardware
- Partial support for Disconnect/Reconnect Mode Page (0x02)
  - Maximum Connect Time Limit - *SUPPORTED*
  - Bus Inactivity Time Limit - *NOT SUPPORTED*
  - Maximum Burst Size - *SUPPORTED*
  - First Burst Size - *NOT SUPPORTED*
- Others...
  - Connection Rate Matching
  - Hard Reset primitive sequence detection and validation in hardware
  - Support for NOTIFY (Enable Spin-up) and NOTIFY (Power Loss Expected)
  - Hashed WWN validation in hardware
  - extended CDB support

## 17.3 SAS Names and Identifiers

In SAS, device and port names are worldwide unique names within a transport protocol. Port identifiers are the values by which ports are identified within a domain, and are used as SAS addresses. Phy identifiers are unique within a device.

**Table 25: Names and identifiers**

Object	SAS Implementation
Port Identifier	SAS address
Port Name	Not defined
Device Name	SAS address
Phy Identifier	Phy identifier

Where the SAS Address format is defined by ANSI as follows:

Byte/Bit	7	6	5	4	3	2	1	0
0	NAA (5h)				(MSB)			
1	IEEE Company ID							
2								
3	(LSB)				(MSB)			
4	Vendor Specific Identifier							
5								
6								
7								



The SAS Device Name is a unique SAS address world wide name. This device name is reported through the SCSI Vital Products Data.

Each of the two SAS ports also has a unique SAS address world wide name. These port identifiers are reported in the IDENTIFY Address frame and are used as source and destination addresses in the OPEN address frame. They are also reported through the SCSI Vital Products Data.

Since this drive is one device with two ports it has three SAS addresses. All SAS Addresses are in 64-bit IEEE Registered Name format, as illustrated in Table 26.

**Table 26: IEEE Registered Name format**

Bit				
63-60	59-36	35-24	23-2	1-0
0101	OUI in Canonical Form	Block Assignment	S/N	Object

The Name Address Authority field (5h) specifies the format used for the rest of the name as follows:

Field	Description
OUI	Organizationally Unique Identifier (24 bits). Canonical form means that each byte is stored in “bit reversed” order.
Block Assignment	Block assignment within HGST, a Western Digital Company
Object	Device Name/Port Identifier 00b    Logical Unit Name 01b    Port 1 10b    Port 2 11b    Target Device Name
S/N	Sequentially increasing drive serial number assigned at manufacturing.

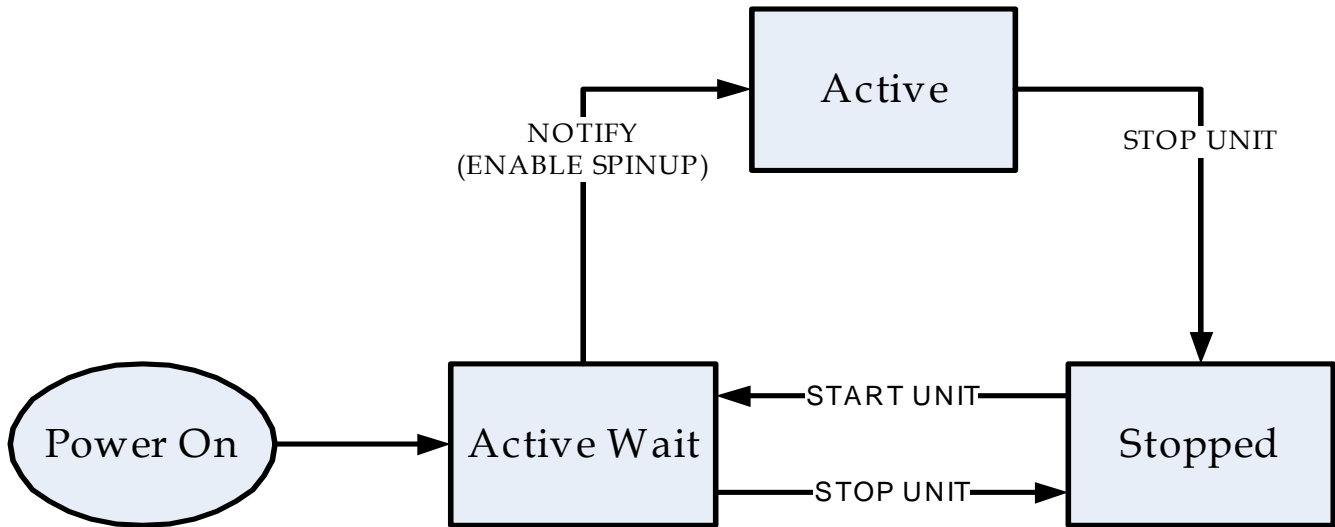
## 17.4 Spin up

The drive supports the Active Wait, Active, and Stopped states specified by the SAS standard. After power on, the drive enters the Active Wait state. The Drive will not spin up its spindle motor after power on until it receives a NOTIFY (Enable Spinup) primitive on either port to enter the Active state. If a NOTIFY (Enable Spinup) primitive is received prior to receiving a Start-Stop Unit command with the Start bit set to one, spin up will begin immediately. For SAS, this is analogous to auto-spinup function in legacy SCSI. This provision allows the system to control the power spikes typically incurred with multiple drives powering on (and spinning up) simultaneously.

If a StartStop command with the Start bit set to one is received prior to receiving a NOTIFY (Enable Spinup), the Drive will not start its spindle motor until Notify (Enable Spinup) is received on either port. Successful receipt of a NOTIFY (Enable Spinup) is a prerequisite to spin up.

If the StartStop Unit command with the Start bit set, also has the immediate bit set, status will be returned prior to actually spinning up the motor, but the actual act of spinning up the motor is deferred until receipt of the NOTIFY (Enable Spinup) primitive. If a media access command is received after sending immediate Status and prior to receiving a NOTIFY (Enable Spinup), the Drive will terminate the command with CHECK CONDITION status with a sense key of NOT READY and an additional sense code of LUN NOT READY, NOTIFY (ENABLE SPINUP) REQUIRED. If a media access command is received after receiving the NOTIFY (Enable Spinup) primitive and before the drive is finished spinning up, the Drive will terminate the command with CHECK CONDITION status with a sense key of LUN NOT READY and an addition sense code of

LUN IS IN THE PROCESS of BECOMING READY.

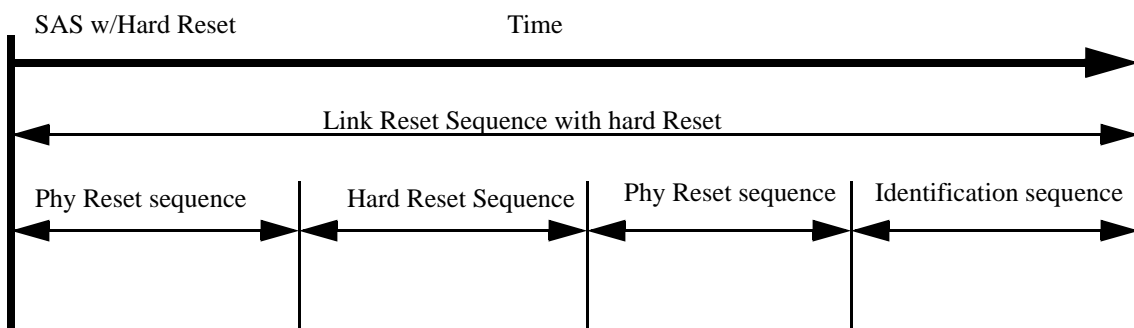
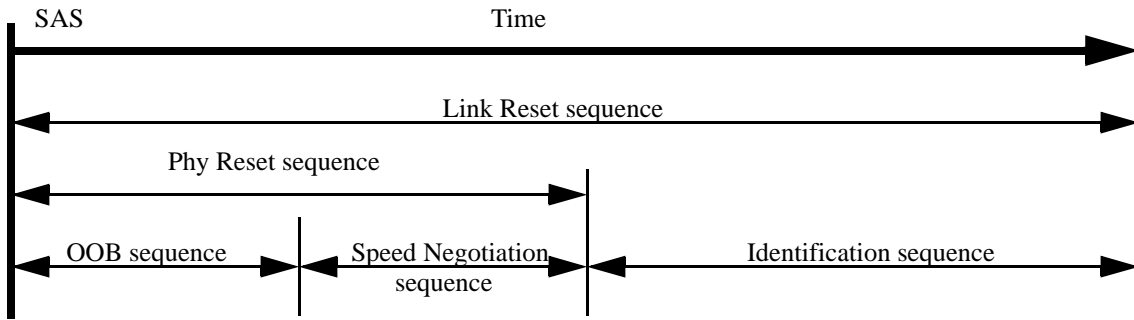


## 17.5 PHY Layer

The Phy layer defines 8b10b coding and OOB signals. The Phy layer is the interface between the link layer and the physical layer. This section describes Phy Layer behaviors of the Drive. For a complete description of SAS Phy Layer, please see the ANSI specification, SAS 1.1.

### 17.5.1 Link Reset Sequence

The Link Reset Sequences for SAS are defined in the SAS 2 ANSI specification and shown below. As show in the diagram, a Phy Reset sequence, consists of an OOB sequence, followed by speed negotiations. Link Reset Sequences will always include a PHY Reset Sequence, followed by an Identification Sequence. Inclusion of a Hard reset sequence is optional. If Hard Reset is performed, it will be preceded by a Phy Reset sequence, and will be followed by Phy Reset/Identification sequences.



## 17.5.2 Hard Reset

A Hard Reset sequence on a port will not affect the other port, but the outstanding commands on the other port will be aborted due to the LUN reset associated with the Hard Reset. The effect of a Hard Reset will be similar to a Power on Reset, and will result in the re-initialization of all Drive resources. The first command issued from every initiator on the port that received the Hard Reset will result in a CHECK CONDITION with a sense key of UNIT ATTENTION and an additional sense code of SCSI BUS RESET OCCURRED. The first command issued from every initiator on the other port will result in a CHECK CONDITION and an additional sense code of BUS DEVICE RESET OCCURRED.

A Hard Reset Sequence will never be issued by the Drive. A link reset will be initiated by the drive on the affected port upon completion of Hard Reset processing.

## 17.5.3 SAS OOB (Out of Band)

Out of band (OOB) signals are low-speed signal patterns detected by the Phy that do not appear in normal data streams. They consist of defined amounts of idle time followed by defined amounts of burst time. During the idle time, D.C. idle is transmitted. During the burst time, ALIGN (0) primitives are transmitted repeatedly. The signals are differentiated by the length of idle time between the burst times.

As a SAS compliant device, the Drive uses three OOB signals: COMINIT/COMRESET and COMWAKE and COMSAS.OOB operations are beyond the scope of this specification. Please refer to the ANSI SAS 2 specification for more details.

The drive will initiate OOB by sending COMINITs, under the following conditions:

- POR
- loss of sync
- Identify timeout

## 17.5.4 SAS Speed Negotiation

The Drive supports G1 (1.5 Gbps), G2 (3.0 Gbps), and G3 (6.0 Gbps) negotiation speeds. The default maximum negotiation rate is G3 speed (per byte 32 in the Phy Control and Discover Mode Page 19 subpage 1). Drive is SAS2 device and supports SNW-1, SNW-2, and SNW-3 speed negotiation with Phy capabilities exchange, and training (Train-SNW). Phy capabilities is defined in table below:

### Phy Capabilities:

Byte /Bit	7	6	5	4	3	2	1	0
0	Start=1b	TX SSC Type = 0b	Reserved		Requested Logical Link Rate = 0h			
1	G1 Without SSC=1b	G1 With SSC=0b	G2 Without SSC=1b	G2 With SSC=0b	G3 Without SSC=1b	G3 With SSC=0b	Reserved	
2	Reserved							
3	Reserved							Parity

- Start bit is 1 to indicate the beginning of the Phy capabilities
- TX SSC Type bit is set to 0 to indicate that Phy's transmitter uses down spreading SCC when is enabled (e.g. the phy is a SAS phy).
- Request Logical Link Rate field is 0 to indicate that drive does not support multiplexing
- G1 Without SSC bit set to 1 indicates that drive supports G1(1.5 Gbps) without SSC
- G2 Without SSC bit set to 1 indicates that drive supports G2(3.0 Gbps) without SSC
- G3 Without SSC bit set to 1 indicates that drive supports G3(6.0 Gbps) without SSC
- G1 With SSC bit set to 1 indicates that drive supports G1(1.5 Gbps) with SSC
- G2 With SSC bit set to 1 indicates that drive supports G2(3.0 Gbps) with SSC
- G3 With SSC bit set to 1 indicates that drive supports G3(6.0 Gbps) with SSC
- Parity bit is set to 1 for even parity of the total number of SNW-3 phy capabilities, including Start bit.

Training is based on the highest untried commonly supported settings on the exchanged SNW-3 supported settings bits. If a Train-SNW is invalid and there are additional, untried, commonly supported settings exchanged during SNW-3, then a new Train-SNW will be performed based on the next highest untried, commonly supported settings. Table 27 defines the priority of the supported settings bits.

**Table 27: Supported Settings Bit Priorities**

Priority	Bit
Highest	G3 With SSC bit
...	G3 Without SSC bit
...	G2 With SSC bit
...	G2 Without SSC bit
...	G1 With SSC bit
Lowest	G3 Without SSC bit

## 17.5.5 PHY Error Handling

This section defines the PHY layer error handling of the drive.

Error	Error Handling Procedure
<b>Link Reset</b>	After POR or Hard Reset, the drive initiates link reset by transmitting exactly 1 COMINIT. For other resets, the drive does not initiate Link Reset.
<b>COMINIT Timeout</b>	If COMINIT or COMSAS is not received before the "Hot Plug Timeout" period expires, the drive continues to transmit DC zero and wait for COMINIT/COM-SAS. Firmware is notified. This is not considered an error.
<b>COMSAS Timeout</b>	If COMINIT is detected, COMSAS is transmitted, and COMSAS is not received before the COMSAS Detect Timeout timer expires, firmware is notified and the drive continues to transmit DC zero and wait for COMINIT.
<b>Speed Negotiation Errors</b>	If speed negotiation fails with no match, or if the drive fails retrying the matched link rate, firmware is notified and the drive continues to transmit DC zero and wait for COMINIT. If the match link rate retry fails, the Phy Reset Problem counter is incremented (Log Page 0x18).
<b>Loss of Sync</b>	If the drive loses DWORD sync long enough for the loss of sync timer to expire, firmware is notified and the drive transmits a COMINIT to initiate a new link reset. The Loss of DWORD sync counter is incremented (Log Page 0x18).
<b>Disparity/Invalid DWORD Error</b>	If a disparity error or an invalid DWORD is detected by the drive, the Invalid DWORD Count is incremented (Log Page 0x18). The Running Disparity Error Count in Log Page 0x18 is not used

## 17.6 Link Layer

The SAS link layer defines primitives, address frames, and connections. The Link layer is the interface between the Port layer and the Phy layer. This section describes Link Layer behaviors of the Drive. For a complete description of SAS Link Layer, please see the ANSI specification, SAS 1.1.

### 17.6.1 Address Frames

Address frames are used for the identification sequence and for connection requests and are only sent outside connections. The Address Frame format is defined below:

**Table 28: Address Frame Format**

Byte	Bit							
	7	6	5	4	3	2	1	0
0	Rsvd	Device Type			Address Frame Type			
1-27	Frame Type Dependent bytes							
28-31	CRC							

- The ADDRESS FRAME TYPE field indicates the type of address frame and is defined in table 29. This field determines the definition of the frame type dependent bytes.

**Table 29: Frame type:**

Value	Address Frame Type Description
0000b	IDENTIFY: Identification Sequence
0001b	OPEN: Connection Request
Others	RESERVED

### 17.6.1.1 Identify Address Frame

The IDENTIFY address frame format is used for the identification sequence. The IDENTIFY address frame is sent after the phy reset sequence completes. The Identify Address Frame format is defined as follows:

**Table 30: Identify Address Frame**

Byte	Bit							
	7	6	5	4	3	2	1	0
0	Rsvd	Device Type = 1			Address Frame Type = 0			
1	Reserved				Reason			
2	Reserved				SSP Initiator Port=0b	STP Initiator Port=0b	SMP Initiator Port=0b	Rsvd
3	Reserved				SSP Target Port=1b	STP Target Port=0b	SMP Target Port=0b	Rsvd
4-11	Device Name							
12-19	SAS Address							
20	PHY Identifier							
21	Reserved				Inside ZPSDS Per-sistent=0b	Requested Inside ZPSDS=0b	Break_Reply Capable=1b	
22-27	Reserved							
28-31	CRC							

- **Device Type:** set to 001b to indicate that this drive is an "End Device".
- **Address Frame Type:** set to 00b to indicate that this is an IDENTIFY.
- **Reason:** field indicates the reason for link reset sequence as defined in Table 31 on page 55
- **Initiator Port bits:** set to 000b since this device is a target device only
- **Target Port bits:** set to 100b since this device is a SSP target device only
- **Device Name:** field contains Target Device Identifier
- **SAS ADDRESS:** field contains the port identifier of the SAS port transmitting this frame.
- **PHY Identifier:** field contains the PHY identifier of the PHY transmitting this frame.
- **Break\_Reply Capable:** set to 1b to indicate that this port is capable of sending BREAK\_REPLY primitive sequence in responding of receiving BREAK primitive sequences

- **Requested Inside ZPSDS:** set to 0b since this is an "End Device"
- **Inside ZPSDS Persistent:** set to 0b since this is an "End Device"

**Table 31: Reason field**

Value	Address Frame Type Description
00b	Power on
01b	OPEN: Connection Request
02b	Hard Reset (received a Hard Reset during hard reset sequence)
04b	Loss of dword synchronization
07b	Break timeout timer expired
08b	Phy test function stopped
Others	RESERVED

### 17.6.1.2 OPEN Address Frame

The OPEN address frame format is used for the identification sequence. The OPEN address frame is sent after the phy reset sequence completes. The OPEN Address Frame format is defined as follows:

Byte	Bit							
	7	6	5	4	3	2	1	0
0	Initiator Port=0	Protocol = 1			Address Frame Type = 1			
1	Features = 0				Connection Rate = 8h or 9h or Ah			
2-3	Initiator Connection Tag							
4-11	Destination SAS Address							
12-19	Source SAS Address							
20	Source Zone Group							
21	Pathway Blocked Count							
22-23	Arbitration Wait Time							
24-27	More Compatible Features							
28-31	CRC							

- **Initiator Port:** This bit is set to zero when the Drive is the source port acting as a SAS target.
- **Protocol:** this field is set to 001b to indicate SSP Protocol.
- **Features:** this field is set to zero and ignored by the Drive per SAS 1.1.
- **Connection Rate:** field should be set to 8h (1.5Gbps) or 9h (3Gbps), depending on requested link rate. Rate matching is supported by the Drive, therefore if the Link to the drive is 3.0Gbps, and the Connection Rate is 1.5Gbps, the Drive will insert ALIGNs between DWords, to match the Connection Rate.
- **Initiator Connection Tag:** The Drive will set this value to the last value received from this Initiator.
- **Destination SAS Address:** field contains the port identifier of the SAS port to which a connection is being requested.
- **Source SAS Address:** field contains the port identifier on the port that originated this frame (i.e. the drive's port address).
- **Source Zone Group:** This field is set to zero and ignored by the Drive per SAS 2.

- **Pathway Blocked Count:** this field indicates the number of times the port has retried this connection request due to receiving OPEN\_REJECT (PATHWAY BLOCKED). The Drive will not increment the PATHWAY BLOCKED COUNT value past FFh.
- **Arbitration Wait Time:** this field indicates how long the port transmitting the OPEN address frame has been waiting for a connection request to be accepted. For values from 0000h to 7FFFh, the Arbitration Wait Time timer increments in one microsecond steps. For values from 8000h to FFFFh, the Arbitration Wait Time timer increments in one millisecond step.
- **More Compatible Features:** this field is set to zero and ignored by the Drive per SAS 1.1.

## 17.6.2 Link Layer Error Handling

This section defines the Link layer error handling of the drive.

Error	Error Handling Procedure
<b>IDENTIFY Timeout</b>	If IDENTIFY is not received before the IDENTIFY timer expires (1ms), firmware is notified and the drive transmits a COMINIT to initiate a new link reset.
<b>BREAK Received</b>	If BREAK is received while the drive has ACK/NAK balance, BREAK or BREAK_REPLY is transmitted and a new connection may be opened if the drive still has frames to transmit. Firmware is not notified. If BREAK is received while the drive does NOT have ACK/NAK balance, BREAK or BREAK_REPLY is transmitted and the current command is aborted and will return Check Condition status with sense data indicating an ACK/NAK timeout.
<b>NAK and ACK/NAK Timeout</b>	If a NAK is received on a RESPONSE frame, the RESPONSE frame is retransmitted with the RETRANSMIT bit set to zero. If an ACK or NAK is not received for a RESPONSE frame within 1ms, the RESPONSE frame will be retransmitted with the RETRANSMIT bit set to one. The drive will retry sending a RESPONSE frame once.
<b>Bad Frame CRC</b>	If a frame fails the CRC check, the frame is NAKed by the drive and discarded. This is a link layer function. The command associated with a NAKed DATA or XFER_RDY frame is aborted with check condition status and sense data corresponding to DATA_PHASE_ERROR is returned. COMMAND frames that fail the CRC check are NAKed and discarded.
<b>OPEN_REJECT</b>	<p>OPEN_REJECT – Retryable Variations</p> <ul style="list-style-type: none"> <li>• OPEN_REJECT(RETRY) - Will be retried indefinitely by the drive. This case is considered to occur when the initiator is temporarily not available to accept connections (for example when it is not able to extend R-Rdy credit at this time due to lack of buffers...), so the initiator will ask us to keep "RETRY"-ing, until it becomes available at a later time. Thus, we don't consider this an error condition, but part of normal behavior for the initiator.</li> <li>• OPEN_REJECT(RATE_NOT_SUPPORTED) – If this occurs, it must mean that a link between the drive and initiator renegotiated to a lower link rate after the command was received. In this case, we retry in a new connection at 1.5Gbps. If this error is received for a 1.5Gbps connection, the command is internally aborted.</li> </ul> <p>OPEN_REJECT – (PATHWAY_BLOCKED)</p> <ul style="list-style-type: none"> <li>• OPEN_REJECT(BAD_DESTINATION), OPEN_REJECT(WRONG_DESTINATION), OPEN_REJECT(PROTOCOL_NOT_SUPPORTED) – If these OPEN_REJECTs are received, we internally abort the command.</li> </ul>



<b>Credit Timeout</b>	If credit is not received before the credit timer expires, DONE(CREDIT_TIMEOUT) is sent to the Initiator.
<b>DONE Timeout</b>	If credit is extended and the DONE timer expires, BREAK is sent by hardware to tear down the connection.
<b>CREDIT_BLOCKED</b>	If CREDIT_BLOCKED is received and the drive has frames to send in the current connection, DONE(CREDIT_TIMEOUT) is returned. Otherwise, DONE(NORMAL) is returned.
<b>OPEN Frame Checking</b>	Reserved fields in the OPEN frame are not checked. <ul style="list-style-type: none"> <li>• The Dest Address field is checked, and if it doesn't match OPEN_REJECT(WRONG_DESTINATION) is returned.</li> <li>• The Protocol field is checked and if it isn't set to SSP OPEN_REJECT(PROTOCOL_NOT_SUPPORTED) is returned.</li> <li>• If the Link Rate exceeds the physical link rate on that port, OPEN_REJECT(LINK_RATE_NOT_SUPPORTED) is returned.</li> <li>• The Initiator bit is not checked.</li> </ul>
<b>OPEN Response Timeout</b>	If AIP or OPEN_ACCEPT is not received before the OPEN Response timer expires, the hardware transmits BREAK.
<b>CLOSE Timeout</b>	If CLOSE is not received before the CLOSE timer expires, the hardware transmits BREAK.
<b>Phy Not Ready</b>	If Link Reset occurs outside of a connection, commands can execute normally across the link reset. If a link reset occurs inside of a connection, the behavior is similar to BREAK in that it is treated as an abruptly closed connection. In cases where the command cannot be continued normally (e.g. a frame is corrupted by OOB signals, or we do not have ACK/NAK balance), the command is terminated with CHECK CONDITION status with sense data corresponding to ACK/NAK TIMEOUT.

## 17.7 Transport Layer

The Transport layer defines frame formats. The Transport layer is the interface between the application layer and port layer. It is responsible for constructing and parsing frame contents. For SSP, the transport layer only receives frames from the port layer that are going to be ACKed by the link layer. This section describes Transport Layer behaviors of the Drive. For a complete description of SAS Transport Layer, please see the ANSI specification, SAS 1.1.

The transport layer defines the frame format as follows.

**Table 32: SAS Frame Format**

Byte	Bit							
	7	6	5	4	3	2	1	0
0	Frame Type							
1-3	Hashed Destination Address							
4	Reserved							
5-7	Hashed Source Address							
8-9	Reserved							
10	Reserved		TLR Control = 00b		Retry Data Frames =0b	Retransmit	Rsvd	
11	Reserved						# of fill bytes	
12-15	Reserved							
16-17	Tag							
18-19	Target Port Transfer Tag							
20-23	Data Offset							
24-m	Information Unit							
	Fill Bytes (if Needed)							
(n-3)-n	CRC							

- **FRAME TYPE** field, which defines the format of the INFORMATION UNIT field as follows:

Code	Name of Frame	Information Unit	Originator	IU Size (bytes)
01h	DATA	Data	Initiator or Target	1-1024
05h	XFER_RDY	Data Transfer Ready	Target	12
06h	COMMAND	Command	Initiator	28-284
07h	RESPONSE	Response	Target	24-1024
16h	TASK	Task Management Function	Initiator	28
f0-ffh	vendor specific			
all others	reserved			

- The **HASHED DESTINATION SAS ADDRESS** field contains the hashed value of the destination SAS address.
- The **HASHED SOURCE SAS ADDRESS** field contains the hashed value of the source SAS address.
- The **TLR CONTROL** field is not supported
- The **RETRY DATA FRAMES** is not supported
- The **CHANGING DATA POINTER** is not supported
- The **NUMBER OF FILL BYTES** field indicates the number of fill bytes between the **INFORMATION UNIT** field and the **CRC** field. The **RETRANSMIT** bit is set to one for **RESPONSE** frames when attempting to retransmit this frame due to receiving an error during the initial transmission. It shall be set to zero for all other frame types. The **NUMBER OF FILL BYTES** field shall be set to zero for all frame types except **DATA** frames
- The **TAG** field contains a value that allows the **SSP** port to establish a context for commands and task management functions.
- The **TARGET PORT TRANSFER TAG** field is set and used by the drive. The initiator should echo this field in out-bound data IU.
- The **INFORMATION UNIT** field contains the information unit, the format of which is defined by the **FRAME TYPE** field.
- **Fill bytes** shall be included after the **INFORMATION UNIT** field so the **CRC** field is aligned on a four byte boundary.

### 17.7.1 Command Information Unit

The **COMMAND** frame is sent by an **SSP** initiator port to request that a command be processed by the drive.

**Table 33: COMMAND Information Unit**

Byte	Bit							
	7	6	5	4	3	2	1	0
0-7	Logical Unit Number							
8	Reserved							
9	Disable first burst=0	Reserved				Task Attribute		
10	Reserved							
11	Additional CDB Length (in Dwords)						Rsvd	
12-27	CDB							
28-n	Additional CDB Bytes							

- The **LOGICAL UNIT NUMBER** field contains the address of the logical unit. The drive only supports a LUN of 0's.
- A **DISABLE FIRST BURST** bit is not supported by the drive
- The **TASK ATTRIBUTE** field is defined as follows:

Value	Attribute
000b	Simple_Q
001b	Head_of_Q

<b>010b</b>	<b>Ordered_Q</b>
<b>100b</b>	<b>ACA_Q (not supported)</b>
<b>101b</b>	<b>Reserved</b>

- The **ADDITIONAL CDB LENGTH** field contains the length in dwords (four bytes) of the **ADDITIONAL CDB** field.
- The **CDB** and **ADDITIONAL CDB BYTES** fields together contain the **CDB**.

## 17.7.2 TASK Information Units

Table 34: TASK Information Unit

Byte	Bit							
	7	6	5	4	3	2	1	0
<b>0-7</b>	<b>Logical Unit Number</b>							
<b>8-9</b>	<b>Reserved</b>							
<b>10</b>	<b>Task Management Function</b>							
<b>11</b>	<b>Reserved</b>							
<b>12-13</b>	<b>Tag of Task to be Managed</b>							
<b>14-27</b>	<b>Reserved</b>							

- The **LOGICAL UNIT NUMBER** field contains the address of the logical unit. The drive only supports a LUN of 0's.
- The **TASK MANAGEMENT FUNCTION** field is defined as follows:

Value	Function
<b>01h</b>	ABORT TASK: The Drive shall perform the ABORT TASK associated with the value of the TAG OF TASK TO BE MANAGED field
<b>02h</b>	ABORT TASK SET: The Drive shall perform the ABORT TASK SET by aborting all outstanding tasks for the Initiator that sent the TMF.
<b>04h</b>	CLEAR TASK SET: This TMF causes the Drive to abort all tasks in the task set. The action is equivalent to receiving a series of Abort Task requests from all Initiators.  A unit attention condition shall be generated for all other Initiators with tasks in the task set. The Additional Sense Code shall be Commands cleared by another Initiator.
<b>08h</b>	LUN RESET: The LUN RESET causes the Target to execute a hard reset. This means: <ol style="list-style-type: none"> <li>1. Abort all tasks for all Initiators on either both ports.</li> <li>2. Release any device reservation on either port.</li> <li>3. Set a Unit Attention condition for all Initiators.</li> </ol>
<b>40h</b>	CLEAR ACA (not supported)
<b>80h</b>	QUERY TASK: The drive shall return a response of FUNCTION SUCCEEDED if the specified task exists, or FUNCTION COMPLETE if the specified task does not exist.
<b>81h</b>	QUERY TASK SET: The drive shall return a response of FUNCTION SUCCEEDED if there is any task exist, or FUNCTION COMPLETE if there is no task exist.

<b>82h</b>	QUERY ASYNCHRONOUS EVENT (formerly QUERY UNIT ATTENTION): The drive shall return a response of FUNCTION SUCCEEDED if there is a unit attention or a deferred error pending, or FUNCTION COMPLETE if there is no unit attention or no deferred error pending.
<b>others</b>	RESERVED: The Drive will return a RESPONSE frame with the DATAPRES field set to RESPONSE_DATA and its RESPONSE CODE field set to TASK MANAGEMENT FUNCTION NOT SUPPORTED.

- If TMF is set to ABORT TASK or QUERY TASK, the **TAG OF TASK TO BE MANAGED** field specifies the **TAG** value from the COMMAND frame that contained the task to be aborted or checked. For all other TMF's, this field is ignored.
- If TMF is set to QUERY ASYNCHRONOUS EVENT, the Additional Response Information argument is set to 000000h for the response of FUNCTION COMPLETE. If the response is FUNCTION SUCCEED, the Additional Response Information argument is set as defined in table 35.

**Table 35: Additional Response Information argument for Query Async Event**

Byte	Bit							
	7	6	5	4	3	2	1	0
<b>0</b>	<b>RESERVED</b>		<b>UADE DEPTH</b>		<b>SENSE KEY</b>			
<b>1</b>	<b>ADDITIONAL SENSE CODE</b>							
<b>2</b>	<b>ADDITIONAL SENSE CODE QUALIFIER</b>							

The UADE DEPTH is the number of pending unit attention conditions or deferred errors. It is defined as in table Table 36:

The SENSE KEY field is the value of the SENSE KEY field in the highest-priority pending unit attention condition or deferred error.

The ADDITIONAL SENSE CODE field is the value of the ADDITIONAL SENSE CODE field in the highest-priority pending unit attention condition or deferred error.

The ADDITIONAL SENSE CODE QUALIFIER field is the value of the ADDITIONAL SENSE CODE QUALIFIER field in the highest-priority pending unit attention condition or deferred error

**Table 36: UADE DEPTH field**

Code	Description
<b>00b</b>	<b>The combined number of unit attention conditions and deferred errors is unknown</b>
<b>01b</b>	<b>The combined number of unit attention conditions and deferred errors is one</b>
<b>10b</b>	<b>The combined number of unit attention conditions and deferred errors is greater than one</b>
<b>11b</b>	<b>Reserved</b>

### 17.7.3 XFER\_RDY Information Units

The XFER\_RDY frame is sent by the Drive to request write data (i.e. out bound data) from the initiator.

**Table 37: XFER\_RDY Information Unit**

Byte	Bit							
	7	6	5	4	3	2	1	0
0 - 3	REQUESTED OFFSET							
4 - 7	WRITE DATA LENGTH							
8 - 11	RESERVED							

- The **REQUESTED OFFSET** field contains the buffer offset of the segment of write data the Initiator may transmit to the Drive (using DATA frames). The requested offset shall be a multiple of four.
- The **WRITE DATA LENGTH** field contains the number of bytes of write data the Initiator may transmit to the Drive (using DATA frames) from the requested offset.

### 17.7.4 DATA Information Units

The DATA frame is sent by the Drive to the Initiator (in bound data) or by the Initiator to the Drive (out bound data).

**Table 38: DATA Information Unit**

Byte	Bit							
	7	6	5	4	3	2	1	0
0 - (n-1)	DATA							

### 17.7.5 RESPONSE Information Units

The RESPONSE frame is sent by the Drive to the Initiator (in bound data) or by the Initiator to the Drive (out bound data).

**Table 39: Response Information Unit**

Byte	Bit							
	7	6	5	4	3	2	1	0
0-7	RESERVED							
8-9	MSB	RETRY DELAY TIMER						LSB
10	RESERVED						DataPres	
11	STATUS							
12 - 15	Reserved							
16 - 19	SENSE DATA LENGTH (n bytes)							
20 - 23	RESPONSE DATA LENGTH (m bytes)							
24 - (24+m)	RESPONSE DATA							
(24+m) - (23+m+n)	SENSE DATA							

- The **RETRY DELAY TIMER** field contains the retry delay timer code which is defined as follows:

Status Code	Retry Delay Timer Code	Description
BUSY	0000h	Same as normal busy
	0001h-FFEFh	The number of 100 milliseconds increments which Initiator should wait before sending another command to Drive
	FFF0h-FFFDh	RESERVED
	FFEFh	Initiator should stop sending commands to Drive
	FFFFh	Drive is not able to accept the command
	0000h	Same as normal busy
QUEUE FULL	0001h-FFEFh	Initiator should wait before sending another command to the Drive until: a) At least the number of 100 milliseconds increments indicated in the RETRY DELAY TIMER CODE field have elapse; or b) A command addressed to the Drive completes.
	FFF0h-FFFFh	RESERVED
GOOD	0000h-FFFFh	RESERVED
CHECKCONDITION	0000h-FFFFh	RESERVED
CONDITION MET	0000h-FFFFh	RESERVED
RESERVATIONCONFLICT	0000h-FFFFh	RESERVED
ACA ACTIVE	0000h-FFFFh	RESERVED
TASK ABORT	0000h-FFFFh	RESERVED

- The **DATAPRES** field, which indicates the format and content of the STATUS field, SENSE DATA LENGTH field, RESPONSE DATA LENGTH field, RESPONSE DATA field, and SENSE DATA field.

Value	DATAPRES Description
00b	NO DATA: no data present
01b	RESPONSE_DATA: response data present
10b	SENSE_DATA: sense data present
11b	RESERVED

**Table 40: RESPONSE DATA**

Byte	Bit							
	7	6	5	4	3	2	1	0
0 - 2	RESERVED							
3	RESPONSE CODE							

• **RESPONSE CODES** are defined as follows:

Value	RESPONSE Code Description
00b	Task Management Function complete
02b	Invalid Frame
04b	Task Management Function not supported
05b	Task Management Function failed
08b	Task Management Function succeeded
09b	Invalid LUN
others	RESERVED

### 17.7.6 Sequences of SSP Information Units

SSP Information Units are used in conjunction with one another to execute SCSI commands. This section provides a brief overview of SAS SSP Information Unit sequences, that would be required to complete a SCSI command.



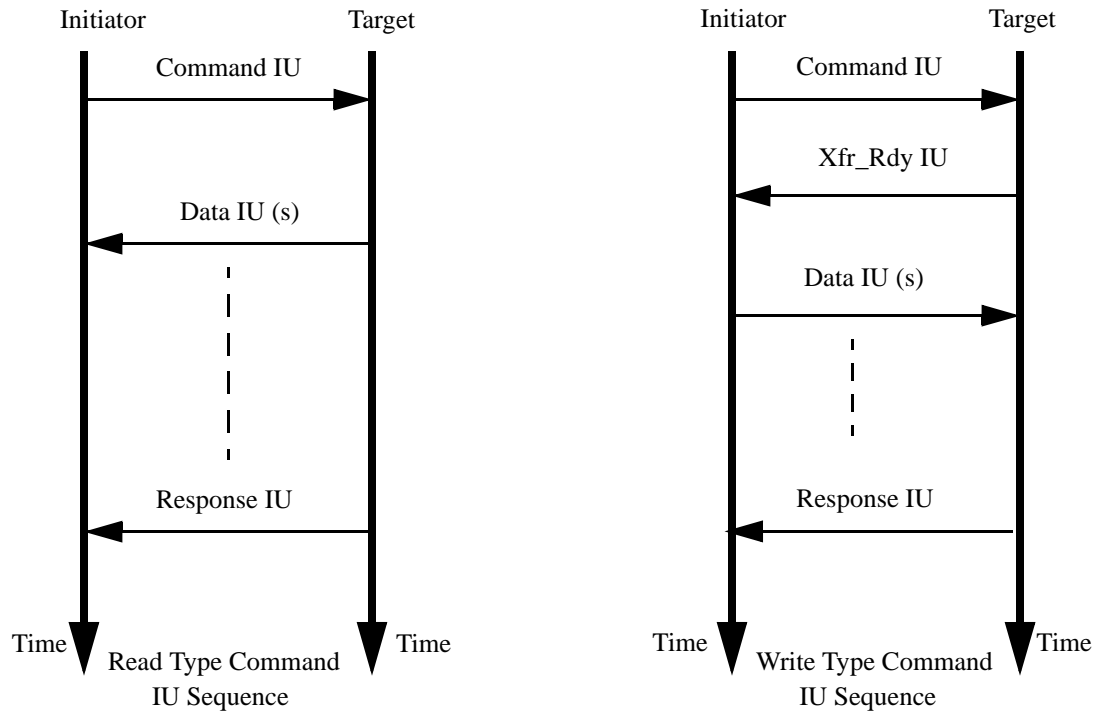


Figure 1: SSP Information Unit Sequences

### 17.7.7 Transport Layer Error Handling

This section defines the Transport layer error handling by the drive.

Error	Error Handling Procedure
<b>SSP Header Field Checking</b>	Reserved fields in SSP frames are not checked.
<b>Data Offset Error</b>	If a DATA frame with an invalid Data Offset is received, the command associated with the DATA frame is aborted with Check Condition status and sense data corresponding to a DATA OFFSET ERROR is returned
<b>I_T NEXUS Loss Timeout</b>	If a connection cannot be established to an initiator before the I_T NEXUS LOSS timer expires (Mode Page 0x19), all commands from the initiator are internally aborted. The first new command received from the affected Initiator results in a CHECK CONDITION with sense data corresponding to I_T NEXUS LOSS OCCURRED.
<b>Initiator Response Timeout</b>	If DATA frames corresponding to an outstanding XFER_RDY frame are not received before the Initiator Response timer expires (Mode Page 0x19), the command is aborted with CHECK CONDITION status and sense data corresponding to INITIATOR RESPONSE TIMEOUT is returned for the affected command.

<b>Data Overflow</b>	If more data is received than requested via an XFER_RDY frame, the affected command is aborted with CHECK CONDITION status with sense data corresponding to TOO MUCH WRITE DATA is returned.
<b>Invalid Target Port Transfer Tag</b>	If a DATA frame is received and the TPTT is not set to the value used in the corresponding XFER_RDY frame, the frame is discarded. If a COMMAND or TASK frame is received with the TPTT set to a value other than 0xFFFF, a RESPONSE frame with RESPONSE_DATA set to INVALID FRAME is returned.
<b>Invalid Frame Length</b>	If a DATA frame is received with zero bytes of payload data, the frame is discarded. This is not considered an error. If a COMMAND/TASK frame that is too short is received, RESPONSE data corresponding to INVALID FRAME is returned. The additional CDB length field of a COMMAND frame is not checked for correctness. If a DATA frame is received with a payload greater than 1024 bytes, the frame is discarded and the command is aborted with CHECK CONDITION status and sense data corresponding to DATA_PHASE_ERROR is returned.

# 18.0 SCSI Command Set

Summaries of the SCSI commands supported by the drive are listed below. O = optional, M = mandatory

**Table 41: SCSI Commands Supported**

Type	Code	Description
M	04h	FORMAT UNIT (04), page 70
M	12h	INQUIRY (12), page 78
O	4Ch	LOG SELECT (4C), page 95
O	4Dh	LOG SENSE (4D), page 98
O	15h	MODE SELECT (15), page 129
O	55h	MODE SELECT (55), page 130
O	1Ah	MODE SENSE (1A), page 131
O	5Ah	MODE SENSE (5A), page 170
O	5Eh	PERSISTENT RESERVE IN (5E), page 171
O	5Fh	PERSISTENT RESERVE OUT (5F), page 174
O	34h	PRE-FETCH (34), page 179
O	90h	PRE-FETCH (90), page 180
M	08h	READ (6) - (08), page 181
M	28h	READ (10) - (28), page 182
O	A8h	READ (12) - (A8), page 184
O	88h	READ (16) - (88), page 185
O	7Fh/09h	READ (32) - (7F/09), page 186
O	3Ch	READ BUFFER (3C), page 188
M	25h	READ CAPACITY (10) - (25), page 192
O	9Eh/10h	READ CAPACITY (16) (9E/10), page 194
O	37h	READ DEFECT DATA (37), page 195
O	B7h	READ DEFECT DATA (B7), page 199
O	3Eh	READ LONG (3E), page 201
O	9Eh	READ LONG (9E), page 202
O	07h	REASSIGN BLOCKS (07), page 203
O	1Ch	RECEIVE DIAGNOSTICS RESULTS (1C), page 205
M	17h	RELEASE (17), page 207
O	57h	RELEASE (57), page 208
O	A3h/05h	REPORT DEVICE IDENTIFIER (A3/05), page 209
O	A0h	REPORT LUNS (A0), page 211
O	A3h/0Ch	REPORT SUPPORTED OPERATION CODES (A3/0C), page 212
O	A3h/0Dh	REPORT SUPPORTED TASK MANAGEMENT FUNCTIONS (A3/0D), page 217
M	03h	REQUEST SENSE (03), page 219
M	16h	RESERVE (16), page 220
O	56h	RESERVE (56), page 221
O	01h	REZERO UNIT (01), page 222
M	1Dh	SEND DIAGNOSTIC (1D), page 223
O	A4h/06h	SET DEVICE IDENTIFIER (A4/06), page 230
O	1Bh	START STOP UNIT (1B), page 231

O	35h	SYNCHRONIZE CACHE (10) - (35), page 234
O	91h	SYNCHRONIZE CACHE (16) - (91), page 235
M	00h	TEST UNIT READY (00), page 236
O	2Fh	VERIFY (10) (2F), page 237
O	AFh	VERIFY (12) - (AF), page 240
O	AFh	VERIFY (16) - (8F), page 241
O	7Fh/0Ah	VERIFY (32) - (7F/0A), page 242
M	0Ah	WRITE (6) - (0A), page 244
M	2Ah	WRITE (10) - (2A), page 245
O	AAh	WRITE (12) - (AA), page 248
O	8Ah	WRITE (16) - (8A), page 249
O	7Fh/0Bh	WRITE (32) - (7F/0B), page 250
O	2Eh	WRITE AND VERIFY (10) - (2E), page 252
O	A Eh	WRITE AND VERIFY (12) - (AE), page 253
O	8Eh	WRITE AND VERIFY (16) - (8E), page 254
O	7Fh/0Ch	WRITE AND VERIFY (32) - (7F/0C), page 255
O	3Bh	WRITE BUFFER (3B), page 256
O	3Fh	WRITE LONG (10) (3F), page 260
O	9Fh	WRITE LONG (16) (9F), page 262
O	41h	WRITE SAME (10) - (41), page 263
O	93h	WRITE SAME (16) - (93), page 264
O	7Fh/0Dh	WRITE SAME (32) - (7F/0D), page 265

## 18.1 SCSI Control Byte

The Control Byte is the last byte of every CDB. The format of this byte is shown below.

**Table 42: SCSI Control Byte**

BIT							
7	6	5	4	3	2	1	0
VU = 0		Reserved = 0					

VU

VU stands for Vendor Unique.

**Note:** \* - The drive ignores the link bit and flag bit in the CDB.

## 18.2 Abbreviations

These abbreviations are used throughout the following sections:

- LUN** Logical Unit Number. An encoded three bit identifier for the logical unit.
- VU** Vendor Unique bits
- LBA** Logical Block Address
- RSVD** Reserved
- MSB** Most Significant Byte
- LSB** Least Significant Byte

## 18.3 Byte ordering conventions

In this specification, where it is not explicitly stated, all multi-byte values are stored with the most significant byte first. For example, in a 4 byte field, byte 0 will contain the MSB and byte 3 the LSB.

## 18.4 FORMAT UNIT (04)

Table 43: FORMAT UNIT (04)

Byte	BIT							
	7	6	5	4	3	2	1	0
0	Command Code = 04h							
1	FMTPINFO		LONG LIST=0	FMT-DATA	CMPLIST	Defect List Format		
2	VU = 0							
3-4	Obsolete = 0							
5	VU = 0		Reserved = 0			FLAG	LINK	

- **FMTPINFO (Format Protection Information)** in combination with the Protection Field Usage field in the Parameter List Header specifies whether or not the drive enables or disables the use of protection information (see table defined in the Parameter List Header section).
- **FmtData** set to one specifies that a Data Out phase follows the Command phase. The Data Out phase consists of a Parameter List header, optionally followed by an Initialization Pattern Descriptor, optionally followed by a Defect List. If FmtData=0, the following defaults are assumed: DPRY=0, DCRT=1, STPF=1, IP=0, DSP=0, Immed=0.
- **CmpLst**
  - Set to one specifies that the Grown Defect List (GList) existing prior to the issuance of the Format Unit command be discarded. If provided, the DList then becomes the GList. Following these operations, the Drive will be formatted with the PList and GList.
  - Set to zero specifies that the GList existing prior to the issuance of the Format Unit command is retained. If provided, the DList is combined with the GList to become the new GList. Following these operations, the Drive will be formatted with the PList and GList.

**Note:** The drive manages two internal defect lists and one external. The Plist is created at time of manufacture. The Glist is built after manufacture by the Initiators' use of the REASSIGN BLOCK command and the Automatic Reallocate functions. The Dlist is an external list. It is supplied by the Initiator in the Data Out phase of the FORMAT UNIT command.

- **Defect List Format** specifies the format of the defect descriptor transferred to the Target when FmtData bit is set to one. The Target supports the following three defect descriptor formats for the FORMAT UNIT command:

### Format Description

<b>000b</b>	Block format
<b>100b</b>	Bytes From Index format
<b>101b</b>	Physical Sector format

If the FmtData bit is set to zero, this field must also be zero. Otherwise the command will complete with a CHECK CONDITION with a sense key of *Illegal Request* and an additional sense code of *Invalid Field in CDB*.

- **Notes:** It is recommended that the MODE SELECT command be issued prior to the FORMAT UNIT command to specify parameters that affect the formatting process.

The Block Length parameter of the Mode Select Parameter List's Block Descriptor is used during formatting and is saved following a successful format operation. If a MODE SELECT command has not been issued since the last reset or start-up (bring-up) sequence, then the Block Length from the previous format operation is used.

Subsequent to receiving a FORMAT UNIT command, the Target responds to commands as follows:

- All commands except REQUEST SENSE and INQUIRY return *Check Condition* status, while the format operation is an active I/O process.
- When tagged queuing is enabled (DQue = 0), all commands except REQUEST SENSE and INQUIRY return *Queue Full* status, while the FORMAT UNIT command is a queued I/O process.
- When tagged queuing is disabled (DQue = 1), all commands except REQUEST SENSE and INQUIRY return *Busy* status, while the FORMAT UNIT command is a queued I/O process.
- If a REQUEST SENSE command is received while a format operation is an active I/O process, the Target returns *Good* status. The sense key is set to *Not ready* and the additional sense code and qualifier is set to *Format In Progress*.
- If an INQUIRY command is received while a format operation is an active I/O process, the Target returns *Good* status and Inquiry data as requested.

The format operation must complete successfully for the Drive to be usable. If the command is interrupted by a reset, power down, or an unrecoverable error, the Drive enters a degraded mode of operation in which reading and writing are prohibited. To exit the degraded mode, another FORMAT UNIT command must be sent by the Initiator and completed successfully by the Target.

The FORMAT UNIT command sets the *Unit Attention Condition* for all Initiators except the one that issued the FORMAT UNIT command.

## 18.4.1 Parameter List Header

Following is the format of the Parameter List Header sent during the data out phase when FmtData is set to one.

**Table 44: Format of the Parameter List Header**

Byte	BIT							
	7	6	5	4	3	2	1	0
0	Reserved = 0				Protection Field Usage			
1	FOV	DPRY	DCRT	STPF =1	IP	Obsolete	Immed	Vendor-specific
2-3	(MSB) Defect List Length				(LSB)			
4-n	Initialization Pattern Descriptor							
(n+1) - m	Defect Descriptor							

- **Protection Field Usage:** in combination with the format protection information (FMTPINFO) field in the CDB specifies whether or not the drive enables or disables the use of protection information:

FMTPINFO	Protection Field Usage	Description
00h	000h	The drive will be formatted to type 0 protection
01h	xxxh	Check Condition status will be returned with the sense key set to Illegal Request and the additional sense code set to Invalid Field in the CDB.
10h	000h	The drive will be formatted to type 1 protection
11h	000h	The drive will be formatted to type 2 protection
11h	001h	Type 3 protection is not supported - Check Condition status will be returned with the sense key set to Illegal Request and the additional sense code set to Invalid Field in the Parameter List

All other combinations of FMTPINFO and Protection Field Usage will result in Check Condition status to be returned with the sense key set to Illegal Request and the additional sense code set to Invalid Field in the Parameter List.

Type 0 protection specifies that the drive shall disable the use of protection information and format to the block size specified. Following a successful format, the PROT\_EN bit in the READ CAPACITY (16) parameter data will indicate that protection information is disabled.

Type 1 and type 2 protection specifies that the drive shall enable the use of protection information and format to the block size specified + 8 (e.g., if the block length is 512, then the formatted block length is 520). See format of data below. When protection information is written during a FORMAT UNIT command, protection information shall be written with a default value of all 0xFF's. Following a successful format, the PROT\_EN bit in the READ CAPACITY (16) parameter data will indicate that protection information is enabled and the P\_TYPE field in the READ CAPACITY (16) parameter data will indicate the protection type.

Byte	BIT							
	7	6	5	4	3	2	1	0
0... n	User Data							
n... n+1	Logical Block Guard							
n+2... n+3	Logical Block Application Tag							
n+4... n+7	Logical Block Reference Tag							

- **The Logical Block Guard field** contains a CRC that covers the preceding user data. This field is generated/checked per the SBC standard.

**The Logical Block Application Tag field** may be modified by the initiator if the ATO bit is set to zero in mode page 0x0A. If the ATO bit is set to one, then the initiator shall not modify the Logical Block Application Tag field. This field is generated/checked per the SBC standard.



- **The Logical Block Reference Tag field** is generated/checked depending on protection types. With Type 1 protection, the Logical Block Reference Tag in the first logical block of the data transfer shall contain the least significant four bytes of the LBA contained in the Logical Block Address field of the command. Subsequent blocks shall contain the previous logical block reference tag plus one. With Type 2 protection, the Logical Block Reference Tag in the first logical block of the data transfer shall contain the value in the Expected Initial Logical Block Reference Tag field of the command. Subsequent blocks shall contain the previous logical block reference tag plus one.
- **FOV** (Format Options Valid) bit set to zero indicates that the Target should use its default settings for the DPRY (0), DCRT (1), STPF (1), IP (0), and DSP (1) bits. These bits must all be set to zero in the Parameter List Header when FOV=0, or the command will be terminated with Check Condition status, sense key of Illegal Request, and additional sense code of Invalid Field in Parameter List. FOV=1 indicates that the values set in DPRY, DCRT, STPF, IP, and DSP will be defined as specified below.
- **DPRY** (Disable Primary) bit set to zero indicates that the Target does not use portions of the medium identified as defective in the primary defect Plist for Initiator addressable logical blocks. If the Target cannot locate the Plist or it cannot determine whether a Plist exists, the Target terminates the FORMAT UNIT command as described for STPF=1. A DPRY bit set to one indicates that the Target does not use the Plist to identify defective areas of the medium. The Plist is not deleted. DPRY must be set to 0 when DCRT is set to 0.
- **DCRT** (Disable Certification) bit set to zero indicates that the Target performs a medium certification operation and generates a Certification List (Clist), and adds the Clist to the Glist. DPRY must be set to 0 when DCRT is set to 0. A DCRT bit of one indicates that the Target does not generate a Clist or perform a certification process.
 

**Note:** Since the DCRT bit is part of the Data Out phase that follows the FORMAT command, the FCERT bit in Mode Page 0 is provided to control certification when the FORMAT command is issued with no Data Out phase. If a FORMAT command is issued with a Data Out phase then FCERT is ignored.
- **STPF** (Stop Format) bit must be set to one. If one or both of the following conditions occurs, the Target terminates the FORMAT UNIT command with *Check Condition* status. The sense key is set to *Medium Error* and the additional sense code is set to *Defect List Not Found* if the first condition occurred or to *Defect List Error* if the second condition occurred.
  - The Target cannot locate a required Dlist nor determine that the list exists.
  - The Target encounters an unrecoverable error while accessing a required Dlist.
- **IP** (Initialization Pattern) bit set to zero specifies that an initialization pattern descriptor is not included and all customer data will be initialized to zeroes. An IP bit of one specifies that an Initialization Pattern Descriptor is included in the FORMAT UNIT parameter list following the parameter list header.

**Table 45: Initialization Pattern Descriptor:**

Byte	BIT							
	7	6	5	4	3	2	1	0
0	IP Modifier = 0		SI	Reserved = 0				
1	Initialization Pattern Type = 0 or 1							
2 - 3	Initialization Pattern Length (n-3)							
4	Initialization Pattern ... Initialization Pattern							
...								
n								

- **IP Modifier** must be set to 0, indicating that the drive will not modify the initialization pattern.
- **SI** (Security Initialize) bit set to one specifies that all customer data sectors, including those that have been previously reassigned, will be initialized. SI set to zero specifies that only the current customer accessible sectors will be formatted.

- **Initialization Pattern Type**
  - Type of 0 will use a default initialization pattern.
  - Type of 1 specifies that the Initialization Pattern specified shall be repeated as required to fill each logical block.
- **Initialization Pattern Length** specifies the number of bytes that follow in the Initialization Pattern field, and must be less than or equal to the current block size, and non-zero.
  - If Initialization Pattern Type is 0 and the Initialization Pattern Length is not set to 0, Check Condition status will be returned, with the sense key set to Illegal Request and the additional sense code set to Invalid Field in Parameter List
  - If Initialization Pattern Type is 1 and the Initialization Pattern Length is set to 0, Check Condition status will be returned, with the sense key set to Illegal Request and the additional sense code set to Invalid Field in Parameter List.
- **DSP** (Disable Saving Parameters) bit when zero indicates the target is to save all the current MODE SELECT saveable parameters during the format operation. When the bit is one, the target is not to save the current MODE SELECT saveable parameters.
- **Immed** (Immediate) bit set to zero requests that status be returned at the end of the format operation. An immediate bit set to one requests that status be returned immediately following CDB validation and transfer of data in the Data Out phase. If the format operation, with the immediate bit set to one, terminates in error, DEFERRED ERROR SENSE data is generated.
- **Defect List Length** field specifies the total length in bytes of the defect descriptors that follow (not including the Initialization Pattern Descriptor, if any). Up to 1024 defect descriptors are allowed. The Defect List Length must be equal to four times the number of defect descriptors for BLOCK format, or eight times the number of defect descriptors for BYTES FROM INDEX and PHYSICAL SECTOR formats. Otherwise the command is terminated with Check Condition status with the sense key set to Illegal Request and the additional sense code set to Invalid Field in Parameter List.

## 18.4.2 Defect Descriptor

Three defect descriptor formats are supported. Entries are not required to be in ascending order. If an entry does not correspond to a valid user addressable media location, the command terminates with Check Condition status with the sense key set to Illegal Request and the additional sense code set to Invalid Field in Parameter List.

### 18.4.2.1 Block Format - 000b

Format of the Dlist sent during the data out phase when Dlist Format is Block format (000b) and FmtData is set to one.

**Table 46: Defect Descriptor - Block Format (for n + 1 defects)**

Byte	BIT							
	7	6	5	4	3	2	1	0
0 - 3	(MSB) Defective Logical Block Address (LSB)							
4n 4n+1 4n+2 4n+3	(MSB) Defective Logical Block Address n (LSB)							

The Block format of the Dlist is the LBA of each defective sector.

**Note:** If a Defective LBA entry, when converted to a physical sector, is equal to the physical sector of a Plist entry and DPRY = 1, then the entry is not added to the Glist.

### 18.4.2.2 Bytes From Index Format - 100b

Format of the Dlist sent during the data out phase when Dlist Format is Bytes From Index format (100b) and FmtData is set to one.

**Table 47: Defect Descriptor - Bytes From Index Format (for n = 1 defects)**

Byte	BIT							
	7	6	5	4	3	2	1	0
0 - 2	(MSB) Cylinder Number of Defect (LSB)							
3	Head Number of Defect							
4 - 7	(MSB) Defect Bytes from Index (LSB)							
8n 8n + 1 8n + 2	(MSB) Cylinder Number of Defect n (LSB)							
8n + 3	Head Number of Defect n							
8n + 4 8n + 5 8n + 6 8n + 7	(MSB) Defect (n) Bytes from Index (LSB)							

Each defect descriptor for the Bytes From Index format specifies that the sector containing this byte be marked defective. The defect descriptor is comprised of the cylinder number of the defect, the head number of the defect, and the number of the defect byte relative to index.

**Note:** If a Byte From Index entry, when converted to a physical sector, is equal to the physical sector of a Plist entry and DPRY = 1, then the entry is not added to the Glist.

### 18.4.2.3 Physical Sector Format - 101b

Format of the Dlist sent during the data out phase when Dlist Format is Physical Sector format (101b) and FmtData is set to one.

**Table 48: Defect Descriptor - Physical Sector Format (for n + 1 defects)**

Byte	BIT							
	7	6	5	4	3	2	1	0
0	<b>(MSB)</b> <b>Cylinder Number of Defect</b> <b>(LSB)</b>							
1								
2								
3	<b>Head Number of Defect</b>							
4	<b>(MSB)</b> <b>Defect Sector Number</b> <b>(LSB)</b>							
5								
6								
7								
8n	<b>(MSB)</b> <b>Cylinder Number of Defect n</b> <b>(LSB)</b>							
8n + 1								
8n + 2								
8n + 3	<b>Head Number of Defect n</b>							
8n + 4	<b>(MSB)</b> <b>Defect (n) Sector Number</b> <b>(LSB)</b>							
8n + 5								
8n + 6								
8n + 7								

Each defect descriptor for the Physical Sector format specifies a defective sector. The defect descriptor is comprised of the cylinder number of the defect, the head number of the defect, and the defect's sector number.

**Note:** If a Physical Sector entry, when converted to a physical sector, is equal to the physical sector of a Plist entry and DPRY = 1, then the entry is not added to the Glist.

## 18.5 INQUIRY (12)

Table 49: INQUIRY (12)

Byte	BIT							
	7	6	5	4	3	2	1	0
0	Operation Code = 12h							
1	Reserved = 0						CmdDt =0	EVPD
2	Page Code							
3 - 4	Allocation Length							
5	VU = 0		Reserved = 0				FLAG	LINK

The INQUIRY command requests the parameters of the Target to be sent to the Initiator.

An **EVPD** An EVPD bit of one specifies that the target return the vital product data page identified by the Page Code field in the CDB. The available VPD pages are defined in the addendum provided for each different drive model in the section entitled Inquiry Data Format.

The **Page Code** specifies which page of vital product data information the drive shall return.

Table 50: Page Code descriptions

EVPD	PAGE CODE	Description
0	0	The Target returns the standard INQUIRY data.
0	Non Zero	The drive returns <i>Check Condition</i> status with the sense key of <i>Illegal Request</i> and the additional sense code of <i>Invalid Field in CDB</i> .
1	Non Zero	The drive returns the vital product data of page code requested.

**Allocation Length** specifies the number of bytes that the Initiator has allocated for INQUIRY data to be returned. An allocation length of zero implies that no data is to be returned. The Target will terminate the DATA IN phase when all available INQUIRY data has been transferred or when allocation length bytes have been transferred, whichever is less.

**Note:** If an INQUIRY command is received from an Initiator with a pending unit attention condition (before the target reports *Check Condition* status), the Target processes the INQUIRY command. The unit attention condition is not cleared by this action.

**Note:** The INQUIRY command is a Priority command and is not queued.

**Note:** The inquiry data is set at the time of manufacture and will not change, with the following exceptions:

- Product Revision Level (EVPD=0) can be changed when microcode is downloaded with the Write Buffer command.
- The information returned for EVPD=1, Page Code = 3 is not fixed.

**Note:** The inquiry data returned when media is not available will not be complete.

Byte 0 of the returned data on an INQUIRY command is the same no matter which page(s) is(are) returned. This description is to be used for all the following page definitions.

The Peripheral Qualifier field of zero (0) indicates that the peripheral device is currently connected to this logical unit. A Peripheral Device Type field of zero (0) indicates that this device is a Direct Access Storage Device (DASD).

## 18.5.1 Inquiry Data

Fields with a value shown inside quotes (e.g. Value = 'xyz') are character fields. A value not in quotes is a numeric value. Character fields are alphanumeric and represented in either ASCII.

### 18.5.1.1 Inquiry Data Format - EVPD = 0, Page Code = 0

Table 51: Inquiry Data- EVPD = 0

Byte	BIT							
	7	6	5	4	3	2	1	0
0	Qualifier = 0			Peripheral Device Type = 0				
1	RMB = 0	Reserved=0						
2	Version = 6							
3	Obsolete	Obsolete	Norm ACA=0	HiSup = 1	Response Data Format = 2			
4	Additional Length = 159 (9Fh)							
5	SCCS=0	ACC=0	TPGS=00b		3PC=0	Reserved = 0		Protect=1
6	Obsolete	EncSer = 0	Port	MultiP=1	Obsolete			RSVD = 0
7	Obsolete	Obsolete	RSVD = 0	RSVD = 0	Obsolete	Obsolete	CmdQue= 1	RSVD = 0
8-15	Vendor ID = "HGST " (ASCII)							
16-31	Product ID (ASCII)							
32-35	Product Revision Level (ASCII)							
36-43	Unit Serial Number (ASCII)							
44-95	Reserved = 0							
96-145	Copyright Notice (ASCII)							
146-163	Reserved=0							

- **Qualifier** is set to zero to indicate that the LUN specified is currently supported. Qualifier is set to 011b when the LUN specified is not present <sup>1</sup>
- **Peripheral Device Type** is set to zero to indicate that the device is a Direct-Access Peripheral Device.
- **Removal Media Bit (RMB)** is always set to zero to indicate no removal media exists.
- **Version** indicates the level of the ANSI standard that the product supports. The drive supports ANSI SPC-4.
- **NormACA** (Normal ACA) field of 0 indicates the device server does not support setting the NACA bit to one in the Control Byte of the CDB as defined in the SAM.
- **HiSup** bit of 1 indicates that the drive uses the hierarchical addressing model to assign LUNs to logical units.
- **Response Data Format** is set to two to indicate that the INQUIRY Data Format as specified in the ANSI SCSI version 2 is supported by the Target.
- **Additional Length** indicates the number of bytes of INQUIRY information that follows.

1.If an INVALID LUN is specified, a *Check Condition* status will be returned for all commands except INQUIRY and REQUEST SENSE.

- **SCCS** bit of zero indicates that the device does not contain an embedded storage array controller component.
- **ACC** bit of zero indicates that no access controls coordinator may be addressed through this logical unit.
- **TGPS** field of zero indicates that the device does not support asymmetric logical unit access.
- **3PC** bit of zero indicates that the device does not support third-party copy commands.
- **Protect** bit of one indicates that the drive supports protection information
- **EncSer**(Enclosure Services) bit of 0 indicates that the Target does not contain an embedded enclosure services component.
- **Port** bit of 0 indicates that the drive received the Inquiry command on port A, while a Port bit of 1 indicates that the drive received the Inquiry command on port B.
- **MultiP** (MultiPort) bit of 1 indicates that the Target has multiple ports and implements multi-port requirements.
- **CmdQue** is set to one to indicate that the drive supports command queuing.
- **Vendor ID** is HGST padded with ASCII blanks.
- **Product ID** is specified in Section 4.3.1
- **Product Revision Level** indicates the level of microcode.
- **Unit Serial Number** contains the drive serial number.

### 18.5.1.2 Inquiry Data Format - EVPD = 1 - Page Code = 00h

Table 52: Inquiry Data - EVPD = 1 (Page Code = 00h)

Byte	BIT							
	7	6	5	4	3	2	1	0
0	Qualifier = 0			Peripheral Device Type = 0				
1	Page Code = 00h							
2	Reserved = 0							
3	Page Length = 09h							
4	Supported Page Code - 00h							
5	Supported Page Code - 03h							
6	Supported Page Code - 80h							
7	Supported Page Code - 83h							
8	Supported Page Code = 86h							
9	Supported Page Code = 87h							
10	Supported Page Code = 88h							
11	Supported Page Code - 90h							
12	Supported Page Code - D1h							
13	Supported Page Code - D2h							

- **Qualifier** is set to zero to indicate that the LUN specified in the Command Block is currently supported.
- **Peripheral Device Type** is set to zero to indicate that the device is Direct Access.
- **Page Code** is set to 0, and this field contains the same value as in the page code field of the INQUIRY command descrip-



tor block.

- **Page length** specifies the length of the following page data.
- **Supported Page Code** field contains the Page Codes supported by the Target. The list is in ascending order.

### 18.5.1.3 Inquiry Data Format - EVPD = 1, Page Code - 03h

Table 53: Inquiry Data - EVPD = 1 (Page Code = 03h)

Byte	BIT							
	7	6	5	4	3	2	1	0
0	Qualifier = 0			Peripheral Device Type = 0				
1	Page Code = 03h							
2	Reserved = 0							
3	Page Length = 184 (B8h)							
4	ASCII Fields Length = 00h							
5-7	Reserved = 0							
8-23	Reserved = 0							
24-35	ASCII uCode Identifier							
36-39	ASCII Servo P/N							
40-41	Major Version							
42-43	Minor Version							
44-47	User Count							
48-51	Build Number							
52-83	Build Date String							
84-91	Product ID							
92-99	Interface ID							
100-107	Code Type							
108-119	User Name							
120-135	Machine Name							
136-167	Directory Name							
168-171	Operating State							
172-175	Functional Mode							
176-179	Degraded Reason							
180-183	Broken Reason							
184-187	Code Mode							

- **Qualifier** is set to zero to indicate that the LUN specified in the Command Block is currently supported.
- **Peripheral Device Type** is set to zero to indicate that the device is Direct Access.
- **Page Code** is set to the value of the page code field in the CDB.
- **Page Length** field specifies the length (in bytes) of the vendor unique VPD information (bytes 4 - 163). If the allocation length of the CDB is too small to transfer all the data, the Page Length field is not adjusted to reflect the truncation.

- **ASCII uCode Identifier** contains the drive's microcode identifier. The field is alphanumeric (ASCII), left aligned, and the unused bytes are ASCII spaces (20h).
- **ASCII Servo P/N** contains the part number of the Servo microcode installed on the drive. This field is hex numeric ASCII (i.e., the characters will be in the set 0...9, A...F).
- **Major Version** and **Minor Version** are version numbers of the code loaded on the drive.
- **User Count** is the number of times the code has been built since the master build.
- **Build Number** is the master build version number.
- **Build Date String** is the date the code on the drive was built, in an extended string format.
- **Product ID** is the name of the product this code is for.
- **Interface ID** is the interface type and serial interface speed (e.g. SAS 6Gbps or FCAL 4Gbps) of the code.
- **Code Type** is the intended use of the this code. (e.g. local, released, test)
- **User Name** is the username of the person who built this version of the code.
- **Machine Name** is the workstation on which this version of the code was built.
- **Directory Name** is the last 32 characters of the directory from where this code was built.
- **Operating State** is the drive operating state. The least significant bit contains the following:

0 = OM_BROKEN	We have detected a hardware failure.
1 = OM_DEGRADED	We have a soft failure; i.e., incomplete format. Motor is still spinning.
2 = OM_INACCESSIBLE	Drive is good but motor is stopped.
3 = OM_STARTING	Motor is starting.
4 = OM_SPINNING	Motor is started but reserved area is not loaded yet.
5 = OM_NORMAL	Drive is spinning and ready to read/write.
6 = OM_SLEEP	Drive is ready but has entered power save mode.
7 = OM_STOPPED	Drive has come ready but now has been stopped.
8 = OM_NOTIFY	Drive is good but NOTIFY has not arrived (SAS)
9 = OM_SUSPEND	Similar to OM_STOPPED, but spin-up is automatic like OM_SLEEP
10 = OM_WAKEUP	Similar to OM_STARTING, but LUN BECOMING READY during spinup is not reported
11 = OM_NOTIFY_WAKEUP	Similar to OM_NOTIFY, but next transition is to OM_WAKEUP

- **Functional Mode** is the drive functional mode. The least significant byte (0x0000000n) contains the following:
 

0 = OM_NORMAL_MODE	Not in special or recovery mode.
1 = OM_SPECIAL_CMD	Special command mode on.
3 = OM_SPC_RSV_ACCESS	Special cmd mode and access to reserved area allowed.
5 = OM_SPC_SDWNLOAD	Special cmd mode and special download allowed.
7 = OM_SPC_RACCESS_SDWNLD	Special cmd, access to reserved area, and special download allowed.

 The second byte (0x000n0000) contains the following:
 

0 = Idle functions are not enabled.
1 = Idle functions are enabled.
- **Degraded Reason** (UECType) is why the file is in a degraded mode; i.e., how to exit this mode.
- **Broken Reason** (UECType) is why the drive believes the hardware is broken.
- **Code Mode** is the type of code the drive is running. The least significant bit contains the following:
 

- 0 = OM_FLASH	Drive is running flash code
- 1 = OM_FLASH_OVERLAY	Drive is running flash overlay code
- 2 = OM_DISK	Drive is running code that has been loaded from disk
- 3 = OM_TRANSIENT	Drive is running code that has been downloaded but not saved

### 18.5.1.4 Inquiry Data Format - EVPD = 1, Page Code - 80h

Table 54: Inquiry Data - EVPD = 1 (Page Code = 80h)

Byte	BIT							
	7	6	5	4	3	2	1	0
0	Qualifier = 0			Peripheral Device Type = 0				
1	Page Code = 80h							
2	Reserved = 0							
3	Page Length = 16 (10h)							
4-19	Serial Number (ASCII)							

- **Qualifier** is set to zero to indicate that the LUN specified in the Command Block is currently supported.
- **Peripheral Device Type** is set to zero to indicate that the device is Direct Access.
- **Page Code** is set to the value of the page code field in the CDB.
- **Page Length** is set to 16, and this field specifies the length of the following page data.
- **Serial Number** gives the drive serial number, right aligned.

### 18.5.1.5 Inquiry Data - EVPD = 1 (Page Code = 83h)

Table 55: Inquiry Data Format - EVPD = 1, (Page Code - 83h)

Byte	BIT							
	7	6	5	4	3	2	1	0
0	Qualifier = 0			Peripheral Device Type = 0				
1	Page Code = 83h							
2	Reserved = 0							
3	Page Length = 72 (48h)							
4	Protocol Identifier = 0				Code Set = 1			
5	PIV=0	RSVD	Association=0		Identifier Type = 3			
6	Reserved = 0							
7	Identifier Length = 8							
8-15	(MSB) LUN (World Wide ID)							(LSB)
16	Protocol Identifier				Code Set = 1			
17	PIV=1	RSVD	Association = 1		Identifier Type = 3			
18	Reserved = 0							
19	Identifier Length = 8							
20-27	(MSB) Target Port Identifier (World Wide ID)							(LSB)
28	Protocol Identifier				Code Set = 1			
29	PIV=1	RSVD	Association = 1		Identifier Type = 4			
30	Reserved = 0							
31	Identifier Length = 4							
32-35	(MSB) Relative Port Identifier							(LSB)
36	Protocol Identifier = 0				Code Set = 1			
37	PIV=1	RSVD	Association = 2		Identifier Type = 3			
38	Reserved = 0							
39	Identifier Length = 8							
40-47	(MSB) Target Device Name Identifier (World Wide ID)							(LSB)
48	Protocol Identifier = 0				Code Set = 3			

49	PIV=0	RSVD	Association=2	Identifier Type = 8
50	Reserved = 0			
51	Identifier Length =24 (18h)			
52-55	"naa" (ASCII)			
56-71	(MSB)	Target Device Name Identifier (World Wide ID) in ASCII		(LSB)
72-75	Reserved = 0			

- **Protocol Identifier** is valid only when PIV=1. Protocol Identifier = 0 indicates Fibre Channel devices. Protocol Identifier = 6 specifies SAS devices
- **Code Set** specifies the data type for the identifier field. Code Set = 1 indicates binary data, Code Set = 3 indicates ASCII.
- **PIV (Protocol Identifier Valid)** set to zero indicates that the Protocol Identifier field should be ignored. PIV set to one indicates that the Protocol Identifier field contains a valid value.
- **Association** specifies the entity with which the Identifier field is associated: 0h for LUN, 1h for Target or Relative Port, or 2h for Target Device.
- **Identifier Type** specifies the format and assignment authority for the identifier: 3h indicates NAA format of the WWID for LUN, Target Port and Target Device; 4h indicates Relative Port; 8h indicates SCSI name string.
- **Identifier** fields contain the actual Identifier Descriptor:
  - The LUN, Target Port and Target Device Name Identifiers are defined in the NAA IEE WWID format where: Worldwide ID is a 64-bit unique identification for each drive. The format is: 5000CCAh xxxh yyb n where:
    - **xxx** is the 12-bit block assignment defined for each model and manufacturing site
    - **n** is the 22-bit drive unique serial number
    - **yy** is the 2-bit port/node ID select
  - The **Relative Port Identifier** indicates the port which received the Inquiry command: 0000 0001h for the Primary Port, or 0000 0002h for the Secondary Port.

### 18.5.1.6 Inquiry Data Format - EVPD = 1, Page Code - 86h

Table 56: Inquiry Data Format - EVPD = 1, (Page Code - 86h)

Byte	BIT							
	7	6	5	4	3	2	1	0
0	Qualifier = 0			Peripheral Device Type = 0				
1	Page Code = 86h							
2	Reserved = 0							
3	Page Length = 60 (3Ch)							
4	Reserved = 0		SPT			GRD_CHK	APP_CHK	REF_CHK
5	Reserved = 0			Group_Sup	Prior_Sup	HEADSUP	ORDSUP	SIMPSUP
6	Reserved=0				WU_SUP	CRD_SUP	NV_SUP	V_SUP
7-63	Reserved = 0							

- **SPT** (Supported Protection Type) field is set to 001b to indicate that the drive supports type 1 and type 2 protection.
- **GRD\_CHK (Guard Check)** is set to one to indicate that the drive checks the Logical Block Guard Tag field in the protection information, if any.

- **APP\_CHK (Application Tag Check)** bit is set to one to indicate that the drive checks the Logical Block Application Tag field in the protection information, if any.
- **REF\_CHK (Reference Tag Check)** bit is set to one to indicate that the drive checks the Logical Block Reference Tag field in the protection information, if any.
- **GROUP\_SUP (Group Supported)** bit is set to zero to indicate that the grouping function is not supported.
- **PRIOR\_SUP (Priority Supported)** bit is set to zero to indicate that task priority is not supported.
- **HEADSUP (Head of Queue Supported)**, **ORDSUP (Ordered Supported)**, and **SIMPSUP (Simple Supported)** are set to one to indicate support for Head of Queue, Ordered and Simple task attributes.
- **WU\_SUP** is set to 1 to indicate that setting the **WR\_UNCOR** bit to one in the Write Long command is supported.
- **CRD\_SUP** is set to 1 to indicate that setting the **COR\_DIS** bit to one in the Write Long command is supported.
- **NV\_SUP (Non-volatile Supported)** is set to 0 to indicated that non-volatile cache features are not supported.
- **V\_SUP (Volatile Supported)** is set to 1 to indicated support of a volatile cache.

### 18.5.1.7 Inquiry Data Format - EVPD = 1, Page Code - 87h

Table 57: Inquiry Data Format - EVPD = 1, (Page Code - 87h)

Byte	BIT							
	7	6	5	4	3	2	1	0
0	Qualifier = 0			Peripheral Device Type = 0				
1	Page Code = 87h							
2-3	Page Length = 0004h							
4	Reserved=0		Policy Page Code = 3Fh					
5	Policy Subpage Code = FFh							
6	MILUS=1	Reserved = 0					Mode PagePolicy = 0	
7	Reserved = 0							

- **Policy Page Code** set to 3Fh and **Policy Subpage Code** set to FFh indicate that the descriptor applies to all mode pages and subpages
- **MILUS (Multiple Logical Units Share)** set to one indicates the policy is shared by multiple logical units.
- **Mode Page Policy** set to 00b indicates that all mode pages and subpages are shared.

### 18.5.1.8 Inquiry Data Format - EVPD = 1, Page Code - 88h

Table 58: Inquiry Data Format - EVPD = 1, (Page Code - 88h)

Byte	BIT							
	7	6	5	4	3	2	1	0
0	Qualifier = 0			Peripheral Device Type = 0				
1	Page Code = 88h							
2-3	Page Length = 48 (0030h)							
4-5	Reserved=0							
6-7	Primary Relative Port = 0001h							
8-9	Reserved = 0							
10-11	Initiator Port Transport ID Length = 0							
12-13	Reserved = 0							
14-15	Primary Target Port Descriptors Length = 0Ch							
16	Protocol Identifier				Code Set = 1			
17	PIV=1	RSVD	Association = 1		Identifier Type = 3			
18	Reserved = 0							
19	Identifier Length = 8							
20-27	(MSB) Primary Target Port Identifier (World Wide ID)							(LSB)
28-29	Reserved = 0							
30-31	Secondary Relative Port = 0002h							
32-33	Reserved = 0							
34-35	Initiator Port Transport ID Length = 0							
36-37	Reserved = 0							
38-39	Secondary Target Port Descriptors Length = 0Ch							
40	Protocol Identifier				Code Set = 1			
41	PIV=1	RSVD	Association = 1		Identifier Type = 3			
42	Reserved = 0							
43	Identifier Length = 8							
44-51	(MSB) Secondary Target Port Identifier (World Wide ID)							(LSB)

- **Protocol Identifier** is valid only when PIV=1. Protocol Identifier = 0 indicates Fibre Channel devices. Protocol Identifier = 6 indicates SAS devices



- **Code Set** specifies the data type for the identifier field. Code Set = 1 indicates binary data
- **PIV (Protocol Identifier Valid)** set to one indicates that the Protocol Identifier field contains a valid value.
- **Association** specifies the entity with which the Identifier field is associated: 1h for Target or Relative Port.
- **Identifier Type** specifies the format and assignment authority for the identifier: 3h indicates NAA format of the WWID for Target Port.
- **Identifier** fields contain the actual Identifier Descriptor.
  - The Target Port Identifiers are defined in the NAA IEE WWID format where:
 

World Wide ID is a 64-bit unique identification for each drive. The format is: 5000CCAh  
xxxh n yyb where xxx is the 12-bit block assignment defined for each model and manufacturing site, n is the 22-bit drive unique serial number, and yy is the 2-bit port/node ID

### 18.5.1.9 Inquiry Data Format - EVPD = 1, Page Code - 8Ah

Table 59: Inquiry Data Format - EVPD = 1, (Page Code - 8Ah)

Byte	BIT							
	7	6	5	4	3	2	1	0
0	Qualifier = 0			Peripheral Device Type = 0				
1	Page Code = 8Ah							
2-3	Page Length = 14 (000Eh)							
4	Reserved=0						STANDBY_Y	STANDBY_Z
5	Reserved=0				IDLE_C	IDLE_B	IDLE_A	
6-7	Stopped Condition Recovery Time							
8-9	Standby_Z Condition Recovery Time							
10-11	Standby_Y Condition Recovery Time							
12-13	Idle_A Condition Recovery Time							
14-15	Idle_B Condition Recovery Time							
16-17	Idle_C Condition Recovery Time							

- **Qualifier** field is set to zero to indicate that the LUN specified in the Command Block is currently supported.
- **Peripheral Device Type** is set to zero to indicate that the device is Direct Access.
- **Page Code** is set to the value of the page code field in the CDB.
- **Page Length** is set to 14, and this field specifies the length of the following page data.
- If set to one, a power condition support bit (**STANDBY\_Y**, **STANDBY\_Z**, **IDLE\_C**, **IDLE\_B**, **IDLE\_A**) indicates that the associated power condition may be entered with START STOP UNIT command and the associated power condition may be entered with a power condition timer if the timer is supported and enabled.
- **The recovery time fields** indicate the time, in one millisecond increments, that the logical unit takes to transition from the associated power condition to the active power condition. This time does not include the processing time for the command that caused this transition to occur. A value of zero indicates that the recovery time is not specified. A value of FFFFh indicates that the recovery time is more than 65.534 seconds.

### 18.5.1.10 Inquiry Data - EVPD = 1, Page Code - 90h

Table 60: Inquiry Data - EVPD = 1 (Page Code = 90h)

Byte	BIT							
	7	6	5	4	3	2	1	0
0	Qualifier = 0			Peripheral Device Type = 0				
1	Page Code = 90h							
2-3	Page Length = 24 (0018h)							
4-15	Protocol-specific logical unit information descriptor 0.							
16-27	Protocol-specific logical unit information descriptor 1.							

- **Qualifier** field is set to zero to indicate that the LUN specified in the Command Block is currently supported.
- **Peripheral Device Type** is set to zero to indicate that the device is Direct Access.
- **Page Code** is set to the value of the page code field in the CDB.
- **Page Length** is set to 24, and this field specifies the length of the following page data.
- **Protocol-specific logical unit information descriptor 0** field is defined in Table 61
- **Protocol-specific logical unit information descriptor 1** field is defined in Table 61

Table 61: Protocol-specific logical unit information descriptor

Byte	BIT							
	7	6	5	4	3	2	1	0
0-1	Relative Port Identifier							
2	Reserved				Protocol Identifier = 6h			
3-5	Reserved							
6-7	Descriptor Length (0004h)							
8	Reserved							TLR CONTROL SUPPORTED = 0h
9-11	Reserved							

- **Relative Port Identifier** is set to 1 for Port A (Primary Port) or 2 for Port B (Secondary Port).
- **Protocol Identifier** is set to 6 to specify that this is a SAS SSP Descriptor.
- **TLR Control Supported** field specifies support of the TLR CONTROL field in the SAS SSP frame header. This field is set to zero to indicate that the drive does not support Transport Layer Retries

### 18.5.1.11 Inquiry Data Format - EVPD = 1, Page Code - B1h

Table 62: Inquiry Data - EVPD = 1 (Page Code = B1h)

Byte	BIT							
	7	6	5	4	3	2	1	0
0	Qualifier = 0			Peripheral Device Type = 0				
1	Page Code = B1h							
2-3	Page Length = 60 (003Ch)							
4-5	Medium Rotation Rate 7200 (1C20h)							
6	Reserved							
7	Reserved				Nominal Form Factor = 3h			
8-63	Reserved							

- **Qualifier** field is set to zero to indicate that the LUN specified in the Command Block is currently supported.
- **Peripheral Device Type** is set to zero to indicate that the device is Direct Access.
- **Page Code** is set to the value of the page code field in the CDB.
- **Page Length** is set to 60, and this field specifies the length of the following page data.
- **Medium Rotation Rate** field is set to 7200.
- **Nominal Form Factor** field is set to 3h.

### 18.5.1.12 Inquiry Data Format - EVPD = 1, Page Code - D1h

Table 63: Inquiry Data - EVPD = 1 (Page Code = D1h)

Byte	BIT							
	7	6	5	4	3	2	1	0
0	Qualifier = 0			Peripheral Device Type = 0				
1	Page Code = D1h							
2	Reserved = 0							
3	Page Length = 80 (50h)							
4-19	ASCII Media Disk Definition							
20-35	ASCII Motor Serial Number							
36-51	ASCII Flex Assembly Serial Number							
52-67	ASCII Actuator Serial Number							
68-83	ASCII Device Enclosure Serial Number							

- **Qualifier** is set to zero to indicate that the LUN specified in the Command Block is currently supported.
- **Peripheral Device Type** is set to zero to indicate that the device is Direct Access.
- **Page Code** is set to the value of the page code field in the CDB.
- **Page Length** is set to 80, and this field specifies the length of the following page data.

**Note:** If the media is not available, bytes 0 through 3 are valid. All the other fields are ASCII blanks (20h).

**Note:** All ASCII fields are alphanumeric, left aligned, and padded on the right with ASCII blanks (20h).

### 18.5.1.13 Inquiry Data Format - EVPD = 1, Page Code - D2h

Table 64: Inquiry Data - EVPD = 1 (Page Code = D2h)

Byte	BIT							
	7	6	5	4	3	2	1	0
0	Qualifier = 0			Peripheral Device Type = 0				
1	Page Code = D2h							
2	Reserved = 0							
3	Page Length = 52 (34h)							
4	HDC Version Length = 16 (10h)							
5 - 20	ASCII HDC Version							
21	Card Serial Number Length = 16 (10h)							
22 - 37	ASCII Card Serial Number							
38	Card Assembly Part Number Length = 16 (10h)							
39 - 54	ASCII Card Assembly Part Number							
55	Reserved = 0							

- **Qualifier** is set to zero to indicate that the LUN specified in the Command Block is currently supported.
- **Peripheral Device Type** is set to zero to indicate that the device is Direct Access.
- **Page Code** is set to the value of the page code field in the CDB.
- **Page Length** is set to 52, and this field specifies the length of the following page data.

**Note:** If the media is not available, bytes 0 through 3 are valid. All the other fields are ASCII blanks (20h).

**Note:** All ASCII fields are alphanumeric, left aligned, and padded on the right with ASCII blanks (20h).

## 18.6 LOG SELECT (4C)

Table 65: Log Select (4C)

Byte	Bit							
	7	6	5	4	3	2	1	0
0	Command Code = 4Ch							
1	Reserved = 0			Reserved = 0			PCR	SP
2	PC		Page Code					
3	SubPage Code = 0							
4-6	Reserved = 0							
7	(MSB) Parameter List Length = 0 (LSB)							
8								
9	Reserved = 0					FLAG	LINK	

The LOG SELECT command provides a means for the Initiator to clear statistical information maintained by the drive and reported via the LOG SENSE command.

- **PCR** The Parameter Code Reset determines whether the Log Sense parameters will be cleared and unit attention posted for all other Initiators. A value of 1 indicates that the parameters be cleared, while a value of zero (except when PC = 11b) indicates that the parameters not be cleared. Parameter list length must be zero when PCR is 1. The PC field is ignored for list parameters, i.e. when the Format and Linking (F&L) field contains 01b or 11b.
- **SP** The Save Parameters bit value of zero indicates that the page parameters not be saved. A value of 1 indicates that the page parameters that are savable be saved after they have been changed. SP bit MUST be 1 if parameter list length is greater than zero. Otherwise it will result in a *Check Condition* status being returned. The sense key shall be set to *Illegal Request* and additional sense code of *Invalid Field in CDB*.
- **PC** The Page Control field defines the type of parameters to be selected. The PC field set to 11b (and PCR is then a don't care) indicates that the Default Cumulative values are set to their default values of 0. If the PC field is set to 01b and PCR is set to 1, the Current Cumulative values are also set to their default values of 0.

Parameter List Length MUST be zero when PC = 11b. Otherwise the command is terminated and a *Check Condition* status is returned. The sense key shall be set to *Illegal Request* and additional sense code of *Invalid Field in CDB*.

- **Page Code** field identifies which page is being selected. This field must be set to the values indicated in Page 0. If the Page Code value is invalid a Check Condition status is returned with a sense key of Illegal Request and additional sense code of Invalid Field in CDB.
  - If page code field is set to zero, then the selection applies to all log parameters in all valid log pages.
  - If page code field is set to a non zero, then the selection applies to all log parameters specified by this field.
- **SubPage Code** This field specifies the subpage to select. This field is not supported and must be set to 0.
- **Parameter List Length** The Parameter List Length field specifies the length in bytes of the parameter list that shall be located in the DATA OUT buffer. A parameter list length zero indicates that no pages shall be transferred.
  - If the PARAMETER LIST LENGTH field is set to zero, then the PCR bit, the SP bit, and the PC fields apply to the page (pages) addressed by the page code field.
  - If The PARAMETER LIST LENGTH field is set to non zero, and the if PAGE CODE field is non-zero or the SUBPAGE CODE field is non-zero, then the command shall be terminated with CHECK CONDITION status, with the sense key set to ILLEGAL REQUEST, and the additional sense code set to INVALID FIELD IN CDB.

**Note:** A specified length greater than 0x00FF will result in a *Check Condition* status being returned. A length that results in log data being truncated will generate a *Check Condition* status.

**Note:** For page 0Fh, the maximum parameter list length supported is 4004h (4 bytes for the header and 100h bytes for each of the 40h parameters that are supported). The Parameter List Length must be an integral of the number of parameters plus the 4 byte header. (Ex: Parameter length =104h for one parameter, 204h for 2 parameters,... 4004h for all 40h parameters).

The drive allows updates to the current cumulative values only. A value of zero is acceptable and is not considered an error. The drive updates only pages 0Eh, the Start/Stop Cycle page and 0Fh, the Application Client page. For other pages the parameters are ignored. If the data out buffer contains multiple pages then the application client should send the pages in ascending order. If the data out buffer contains multiple log parameters within a page, all log parameters within the page should be sent and they should be sent in ascending order by parameter code value. The drive shall return Check Condition status if the application client sends pages out of order, parameter codes out of order or missing parameter code. The sense key shall be set to Illegal Request and additional sense code set to Invalid Field in Parameter List. If one or more fields of the CDB are not set correctly the command will be terminated with a *Check Condition* status. The sense key shall be set to *Illegal Request* and additional sense code of *Invalid Field in CDB*. To indicate that parameters have changed, the Target generates a unit attention condition for all Initiators except the one that issued the LOG SELECT command.

The following list contains all individual page parameters (counters) that are set to their default value of zero by the LOG SELECT command (when PCR=1).

- Page **02h** parameters: (Counters for write errors)
  - Write errors recovered without delay
  - Write errors recovered with possible delays
  - LBAs with write fault error
  - Reserved=0
  - Total errors recovered
  - Number of times recovery invoked
  - Total write byte count
  - LBAs with hard error
- Page **03h** parameters: (Counters for read errors)
  - Read errors recovered without delay
  - Read errors recovered with possible delays
  - LBAs with LDPC detected error
  - Reserved=0
  - Total errors recovered
  - Number of times recovery invoked
  - Total read byte count
  - LBAs with hard error.
- Page **05h** parameters: (Counters for Verify Errors)
  - Errors recovered without delay
  - Errors recovered with possible delays
  - LBAs with LDPC detected error
  - Reserved=0



- Total errors recovered
- Number of times recovery invoked
- Total bytes verified
- LBAs with hard error.
- Page **06h** parameters: (Counters for non medium errors, seek and other hardware type failures)
  - Non-Medium Error Counter
- Page **15h** parameters: (Background Medium Scan information)
  - BMS Status parameter
  - all Medium Scan parameters
- Page **18h** parameters (SAS PHY Error counts - only cleared for the port which receives the Log Select)
  - Invalid DWORD Count
  - Running Disparity Error Count
  - Loss of DWORD Synchronization Count
  - PHY Reset Problem Count
- Page **30h** parameters:
  - Zero Seeks counter
  - Seeks  $\geq$  to 2/3 counter
  - Seeks  $\geq$  1/3 and  $<$  2/3 counter
  - Seeks  $\geq$  1/6 and  $<$  1/3 counter
  - Seeks  $\geq$  1/12 and  $<$  1/6 counter
  - Seeks  $>$  0 and  $<$  1/12 counter
  - Overrun Counter
  - Under run Counter
  - Device Cache Full Read Hits
  - Device Cache Partial Read Hits
  - Device Cache Write Hits
  - Device Cache Fast Writes
  - Device Cache Misses on Reads
- Page **37h** parameters:
  - Media EXC
  - Hardware EXC
  - Total Read Commands
  - Total Write Commands

## 18.7 LOG SENSE (4D)

Table 66: Log Sense (4D)

Byte	Bit							
	7	6	5	4	3	2	1	0
0	Command Code = 4Dh							
1	Reserved = 0			Reserved = 0			PPC=0	SP
2	PC	Page Code						
3	Subpage Code = 0							
4	Reserved = 0							
5	(MSB) Parameter Pointer = 0 (LSB)							
6								
7	(MSB) Allocation Length (LSB)							
8								
9	Reserved = 0					FLAG	LINK	

The LOG SENSE command allows the Initiator to retrieve the statistical data regarding the drive.

- **PPC** (Parameter Pointer Control) bit must be set to zero. This specifies that the drive start transferring data starting from the field specified in the parameter pointer field for the number of bytes specified by the allocation length. If the PPC bit is set to 1, *Check Condition* status is returned with a sense key of *Illegal Request* and additional sense code of *Invalid Field in CDB*.
- **SP** (Save Parameters) bit set to 0 specifies that the drive does not save any log parameters. If it is set to 1, all page parameters that are savable (those pages denoted by a DS = 0 in the parameter header control byte) are saved.
- **PC** (Page Control) field defines the type of parameters to be selected. This field must be set to 01b to specify the current cumulative values. Any other value in this field will cause the command to end with a *Check Condition* status with a sense key of *Illegal Request* and an additional sense code of *Invalid Field in CDB*.
- **Page Code** field identifies which page is being requested. This field must be set to the values indicated in Page 0. If the Page Code value is invalid a *Check Condition* status is returned with a sense key of *Illegal Request* and additional sense code of *Invalid Field in CDB*.
- **SubPage Code** This field specifies the subpage to select. This field is not supported and must be set to 0.
- **Parameter Pointer Field** specifies the beginning field for the transfer. This field must be set to 0000h. If the Parameter Pointer Field is not zero a *Check Condition* status is returned with a sense key of *Illegal Request* and additional sense code of *Invalid Field in CDB*.
- **Allocation Length** field specifies the maximum number of bytes the Initiator has allocated for returned Log Sense Data. No bytes are transferred if the length is zero. This condition is not considered an error. The Target terminates the Data In phase when all available Log Sense data has been transferred or when the number of bytes equals the allocation length, whichever is less.

## 18.7.1 Log Page parameters

Each log page begins with a 4-byte page header followed by zero or more variable-length log parameters.

### Page header

Page Code field identifies which log page is being transferred.

The Page Length field specifies the length in bytes of the following log parameters.

### Log parameters

Each log parameter begins with a 4-byte parameter header followed by one or more bytes of parameter value data.

The Parameter Code field identifies which log parameter is being transferred for that log page.

The Parameter Control field, the 3rd byte of each parameter header, contains several fields.

- **DU** The Disable Update bit is set to 0 to indicate that the drive updates the log parameter value to reflect events that should be noted by that parameter.
- **TSD** The Target Save Disable bit is set to zero to indicate that the drive provides a Target defined method for saving log parameters.
- **ETC** The enable Threshold Comparison bit is set to 0 to indicate the drive does not perform comparisons between cumulative and any threshold values.
- **TMC** The Threshold Met Criteria field is not valid because this drive does not perform threshold comparisons. This field is set to 0.
- **Format and Linking** The F & L field indicates the type of log parameter and how parameters that reach their maximum value are handled.
  - 00b: Data counter: If any other parameter in this log page reaches its maximum value, then this parameter shall stop incrementing until reinitialized by a Log Select command.
  - 01b: List format ASCII data: No maximum values to handle
  - 10b: Data counter: If another parameter reported in this log page reaches its maximum value, then this parameter shall not stop incrementing. This parameter may be reinitialized by a Log Select command.
  - 11b: List format binary data: No maximum values to handle.

## 18.7.2 Log Sense Page 0

Page 0 indicates the supported log sense pages. This page is used to determine which additional pages an Initiator can request.

**Table 67: Log Sense Page 0**

Byte	Bit							
	7	6	5	4	3	2	1	0
0	Reserved		Page code = 0					
1	Reserved							
2-3	Page Length = 000E(Number of Pages Supported)							
4	First supported page 00h							
5	Second supported page 02h							
6	Third supported page 03h							
7	Fourth supported page 05h							
8	Fifth supported page 06h							
9	Sixth supported page 0Dh							
10	Seventh supported page 0Eh							
11	Eighth supported page 0Fh							
12	Ninth supported page 10h							
13	Tenth supported page 15h							
	Eleventh supported page 18h							
14	Twelfth supported page 2Fh							
15	Thirteenth supported Page Code =30h							
16	Fourteenth supported Page Code = 37h							

### 18.7.3 Log Sense Page 2

This page contains counters for write errors.

**Table 68: Log Sense Page 2 (part 1 of 2)**

Byte	Bit							
	7	6	5	4	3	2	1	0
0	Reserved		Page code = 02h					
1	Reserved							
2-3	PageLength = 54h							
4-5	Parameter Code = 0000h							
6	DU = 0	DS = 0	TSD = 0	ETC = 0	TMC = 0		F&L = 00b	
7	Parameter Length = 08h							
8-15	Errors recovered without delay							
16-17	Parameter Code = 0001h							
18	DU = 0	DS = 0	TSD = 0	ETC = 0	TMC = 0		F&L = 00b	
19	Parameter Length = 08h							
20-27	Errors recovered with possible delays							
28-29	Parameter Code = 0002h							
30	DU = 0	DS = 0	TSD = 0	ETC = 0	TMC = 0		F&L = 00b	
31	Parameter Length = 08h							
32-39	Reserved = 0							
40-41	Parameter Code = 0003h							
42	DU = 0	DS = 0	TSD = 0	ETC = 0	TMC = 0		F&L = 00b	
43	Parameter Length = 08h							
44-51	Total errors recovered							
52-53	Parameter Code = 0004h							
54	DU = 0	DS = 0	TSD = 0	ETC = 0	TMC = 0		F&L = 00b	
55	Parameter Length = 08h							
56-63	Times recovery invoked							

**Table 69: Log Sense Page 2 (part 2 of 2)**

Byte	Bit							
	7	6	5	4	3	2	1	0
64-65	Parameter Code = 0005h							

<b>66</b>	<b>DU = 0</b>	<b>DS = 0</b>	<b>TSD = 0</b>	<b>ETC = 0</b>	<b>TMC = 0</b>	<b>F&amp;L = 00b</b>
<b>67</b>	<b>Parameter Length = 08h</b>					
<b>68-75</b>	<b>Total bytes written</b>					
<b>76-77</b>	<b>Parameter Code = 0006h</b>					
<b>78</b>	<b>DU = 0</b>	<b>DS = 0</b>	<b>TSD = 0</b>	<b>ETC = 0</b>	<b>TMC = 0</b>	<b>F&amp;L = 00b</b>
<b>79</b>	<b>Parameter Length = 08h</b>					
<b>80-87</b>	<b>Count of hard errors</b>					

All parameter counts indicate the number of sectors with the specified types of errors, except Times Recovery Invoked, which is a cumulative count of all recovery steps attempted on all sectors written.

## 18.7.4 Log Sense Page 3

This page contains counters for read errors.

**Table 70: Log Sense Page 3 (part 1 of 2)**

Byte	Bit							
	7	6	5	4	3	2	1	0
0	Reserved		Page code = 03h					
1	Reserved							
2-3	PageLength = 54h							
4-5	Parameter Code = 0000h							
6	DU = 0	DS = 0	TSD=0	ETC = 0	TMC = 0		F&L = 00b	
7	Parameter Length = 08h							
8-15	Errors recovered without delay							
16-17	Parameter Code = 0001h							
18	DU = 0	DS = 0	TSD = 0	ETC = 0	TMC = 0		F&L = 00b	
19	Parameter Length = 08h							
20-27	Errors recovered with possible delays							
28-29	Parameter Code = 0002h							
30	DU = 0	DS = 0	TSD=0	ETC = 0	TMC = 0		F&L = 00b	
31	Parameter Length = 08h							
32-39	Reserved = 0							
40-41	Parameter Code = 0003h							
42	DU = 0	DS = 0	TSD=0	ETC = 0	TMC = 0		F&L = 00b	
43	Parameter Length = 08h							
44-51	Total errors recovered							
52-53	Parameter Code = 0004h							
54	DU = 0	DS = 0	TSD=0	ETC = 0	TMC = 0		F&L = 00b	
55	Parameter Length = 08h							
56-63	Times recovery invoked							
64-65	Parameter Code = 0005h							

**Table 71: Log Sense Page 3 (part 2 of 2)**

Byte	Bit							
	7	6	5	4	3	2	1	0

<b>66</b>	<b>DU = 0</b>	<b>DS = 0</b>	<b>TSD = 0</b>	<b>ETC = 0</b>	<b>TMC = 0</b>	<b>F&amp;L = 00b</b>
<b>67</b>	<b>Parameter Length = 08h</b>					
<b>68-75</b>	<b>Total bytes read</b>					
<b>76-77</b>	<b>Parameter Code = 0006h</b>					
<b>78</b>	<b>DU = 0</b>	<b>DS = 0</b>	<b>TSD = 0</b>	<b>ETC = 0</b>	<b>TMC = 0</b>	<b>F&amp;L = 00b</b>
<b>79</b>	<b>Parameter Length = 08h</b>					
<b>80-87</b>	<b>Count of hard errors</b>					

All parameter counts indicate the number of sectors with the specified types of errors, except Times Recovery Invoked, which is a cumulative count of all recovery steps attempted on all sectors read. LDPC-on-the-fly correction is not included in any counters.



## 18.7.5 Log Sense Page 5

This page contains counters for verify errors.

**Table 72: Log Sense Page 5 (part 1 of 2)**

Byte	Bit							
	7	6	5	4	3	2	1	0
0	Reserved		Page code = 05h					
1	Reserved							
2-3	PageLength = 54h							
4-5	Parameter Code = 0000h							
6	DU = 0	DS = 0	TSD = 0	ETC = 0	TMC = 0		F&L = 00b	
7	Parameter Length = 08h							
8-15	Errors recovered without delay							
16-17	Parameter Code = 0001h							
18	DU = 0	DS = 0	TSD = 0	ETC = 0	TMC = 0		F&L = 00b	
19	Parameter Length = 08h							
20-27	Errors recovered with possible delays							
28-29	Parameter Code = 0002h							
30	DU = 0	DS = 0	TSD = 0	ETC = 0	TMC = 0		F&L = 00b	
31	Parameter Length = 08h							
32-39	Reserved = 0							
40-41	Parameter Code = 0003h							
42	DU = 0	DS = 0	TSD = 0	ETC = 0	TMC = 0		F&L = 00b	
43	Parameter Length = 08h							
44-51	Total errors recovered							
52-53	Parameter Code = 0004h							
54	DU = 0	DS = 0	TSD = 0	ETC = 0	TMC = 0		F&L = 00b	
55.	Parameter Length = 08h							
56-63	Times recovery invoked							
64-65	Parameter Code = 0005h							

**Table 73: Log Sense Page 5 (part 2 of 2)**

Byte	Bit							
	7	6	5	4	3	2	1	0
66	DU = 0	DS = 0	TSD = 0	ETC = 0	TMC = 0		F&L = 00b	
67	Parameter Length = 08h							
68-75	Total Bytes Verified							
76-77	Parameter Code = 0006h							
78	DU = 0	DS = 0		TSD = 0	TMC = 0		F&L = 00b	
79	Parameter Length = 08h							
80-87	Count of hard errors							

All parameter counts indicate the number of sectors with the specified types of errors, except Times Recovery Invoked, which is a cumulative count of all recovery steps attempted on all sectors verified. LDPC-on-the-fly correction is not included in any counters.

## 18.7.6 Log Sense Page 6

This page contains counters for non-medium errors. This includes seek errors and other hardware type failures.

**Table 74: Log Sense Page 6**

Byte	Bit							
	7	6	5	4	3	2	1	0
0	Reserved		Page code = 06h					
1	Reserved							
2-3	PageLength = 0Ch							
4-5	Parameter Code = 00h							
6	DU = 0	DS = 0	TSD = 0	ETC = 0	TMC = 0		F&L = 00b	
7	Parameter Length = 08h							
8-15	Error count							

## 18.7.7 Log Sense Page D

This page contains temperature information.

**Table 75: Log Sense Page D**

Byte	Bit							
	7	6	5	4	3	2	1	0
0	Reserved		Page code = 0Dh					
1	Reserved							
2-3	PageLength = 0Ch							
4-5	Parameter Code = 0000h							
6	DU = 0	DS = 1	TSD = 0	ETC = 0	TMC = 0		F&L = 00b	
7	Parameter Length = 02h							
8	Reserved							
9	Temperature (degrees Celsius)							
10-11	Parameter Code 0001h							
12	DU = 0	DS = 1	TSD = 0	ETC = 0	TMC = 0		F&L = 00b	
13	Parameter Length = 02h							
14	Reserved							
15	Reference Temperature (degrees Celsius)							

## 18.7.8 Log Sense Page E

This page contains the start-stop cycle information.

**Table 76: Log Sense Page E**

Byte	Bit							
	7	6	5	4	3	2	1	0
0	Reserved		Page code = 0Eh					
1	Reserved							
2-3	PageLength = 34h							
4-5	Parameter Code = 0001h							
6	DU=0	DS=1	TSD=0	ETC=0	TMC = 0		F&L = 00b	
7	Parameter Length = 06h							
8-11	Year of Manufacture (4 ASCII characters)							
12-13	Week of Manufacture (2 ASCII characters)							
14-15	Parameter Code 0002h							
16	DU=0	DS=0	TSD=0	ETC=0	TMC = 0		F&L = 00b	
17	Parameter Length = 06h							
18-21	Accounting Date Year (4 ASCII characters)							
22-23	Accounting Date Week (2 ASCII characters)							
24-25	Parameter Code 0003h							
26	DU=0	DS=1	TSD=0	ETC=0	TMC = 0		F&L = 00b	
27	Parameter Length = 04h							
28-31	Specified cycle count over device lifetime							
32-33	Parameter Code 0004h							
34	DU=0	DS=1	TSD=0	ETC=0	TMC = 0		F&L = 00b	
35	Parameter Length = 04h							
36-39	Accumulated start-stop cycles (4 byte binary number)							
40-41	Parameter Code 0005h							
42	DU=0	DS=1	TSD=0	ETC=0	TMC = 0		F&L = 00b	
43	Parameter Length = 04h							
44-47	Specified load unload count over device lifetime							
48-49	Parameter Code 0006h							
50	DU=0	DS=1	TSD=0	ETC=0	TMC = 0		F&L = 00b	

<b>51</b>	<b>Parameter Length = 04h</b>
<b>52-55</b>	<b>Accumulated load unload cycles (4 byte binary number)</b>

The week and year that the device was manufactured shall be set in the parameter field defined by parameter code 0001h. The date of manufacture cannot be saved using the LOG SELECT command. The data is expected in numeric ASCII characters (30-39h) in the form YYYYWW. The accounting date specified by parameter code 0002h is a parameter that can be saved using the LOG SELECT command.

## 18.7.9 Log Sense Page F

This page contains the Application Client Log.

**Table 77: Log Sense Page F**

Byte	Bit							
	7	6	5	4	3	2	1	0
0	Reserved		Page code = 0Fh					
1	Reserved							
2-3	Page length = 4000h							
	Application client log parameter							
4-259	1st application client log parameter							
16132-16387	64th application client log parameter							

The following table describes the application client log parameter structure.

**Table 78: Log Sense Page F, Application Client Log**

Byte	Bit							
	7	6	5	4	3	2	1	0
0-1	Parameter code							
2	DU = 1	DS = 0	TSD = 0	ETC = 0	TMC = 0		F&L = 00b	
3	Parameter length = FCh							
4-	First parameter byte							
255	Last parameter byte							

Parameter code 0000h through 003Fh are supported.

The values stored in the parameter bytes represent data sent to the device in a previous LOG SELECT command.

## 18.7.10 Log Sense Page 10

This page contains self-test results. The results of the 20 most recent self-tests are stored in this Log page.

**Table 79: Log Sense Page 10**

Byte	Bit							
	7	6	5	4	3	2	1	0
0	Reserved		Page code = 10h					
1	Reserved							
2-3	PageLength = 190h							
4-23	1st self-test results log parameter							
384- 403	20th self-test results log parameter							

The following table describes the self-test results log parameter structure

**Table 80: Log Sense Page 10, self-test results**

Byte	Bit							
	7	6	5	4	3	2	1	0
0-1	Parameter code							
2	DU = 0	DS = 0	TSD = 0	ETC = 0	TMC = 0		F&L = 11b	
3	Parameter Length = 10h							
4	Function Code			RSVD	Self-Test Results Value			
5	Extended Segment Number							
6-7	Timestamp							
8-15	LBA of First Failure							
16	Reserved				Sense Key			
17	Additional Sense Code							
18	Additional Sense Code Qualifier							
19	Vendor specific							

- **Parameter Code** identifies the log parameter for the log page. The parameter code field for the results of the most recent test will be 0001h. The parameter for the next most recent will be 0002h.
- **Function Code** contains the content of the Function Code field in the SEND DIAGNOSTIC command that initiated this self-test.
- **Self-Test Results Value** is described in the table below.



**Table 81: Log Sense Page 10, self-test results**

<b>Value</b>	<b>Description</b>
<b>0h</b>	The self-test routine completed without error.
<b>1h</b>	The background self-test routine was aborted by the initiator using a SEND DIAGNOSTIC command with the Abort Background self-test function.
<b>2h</b>	The self-test routine was aborted by the application client by a Task Management function or a reset.
<b>3h</b>	An unknown error occurred while the Target was executing the self-test routine and the Target was unable to complete the self-test routine.
<b>4h</b>	The self-test completed with a test element that failed and it is not known which test element failed.
<b>5h</b>	The first segment of the self-test failed.
<b>6h</b>	The second segment of the self-test failed.
<b>7h</b>	The third or greater segment of the self-test failed (see the Extended segment number field).
<b>8h-Eh</b>	Reserved.
<b>Fh</b>	The self-test is in progress.

- **Extended Segment Number** This field identifies the number of the segment that failed during self-test. If no segment failed, this field will be 00h.

**Table 82: Log Sense Page 10, Extended Segment Number**

<b>Extended Segment Number</b>	<b>Short Self-Test</b>	<b>Extended Self-Test</b>
<b>1h</b>	<b>Drive Ready Test</b>	
<b>2h</b>	<b>Drive Diagnostics</b>	
<b>3h</b>	<b>SMART</b>	
<b>4h</b>	<b>Low Level Format check</b>	
<b>5h</b>	<b>Physical Head Check</b>	
<b>6h</b>	<b>Random Verify</b>	
<b>7h</b>	- Verify First 300 MB - Verify Last 100 MB	<b>Verify all LBAs</b>
<b>8h</b>	<b>Recheck SMART</b>	

- **Timestamp** This field contains the total accumulated power-on hours of the Target at the time the self-test completed.
- **LBA of first failure** This field contains the LBA of the first logical block address where a self-test error occurred. If no errors occurred during the self-test or the error is not related to a LBA then the field will be FFFFFFFFFFFFFFFFh.
- **Sense Key, Additional Sense Code and Additional Sense Code Qualifier** These fields will contain the additional information relating to the error or exception conditions during self-test.

See Section 18.40 “SEND DIAGNOSTIC (1D)” on page 223, for detailed listing of operations carried out by SEND DIAGNOSTIC command and Power on Diagnostics.

## 18.7.11 Log Sense Page 15

This page contains information about Background Medium Scan operations.

**Table 83: Log Sense Page 15**

Byte	Bit							
	7	6	5	4	3	2	1	0
0	Reserved		Page code = 15h					
1	Reserved							
2-3	Page Length = (19 + 24N -3)							
	Background Medium Scan parameters							
4-19	BMS Status Parameter							
20-43	First Medium Scan Parameter							
	...							
19+24N	Last Medium Scan Parameter							

The following table describes the BMS Status Parameter structure.

Byte	Bit							
	7	6	5	4	3	2	1	0
0-1	Parameter Code = 0000h							
2	DU=0	DS=0	TSD=0	ETC=0	TMC=0		F&L = 11b	
3	Page Length = 0Ch							
4-7	Power On Minutes							
8	Reserved = 0							
9	BMS Status							
10-11	Number of Background Scans Performed							
12-13	Medium Scan Progress							
14-15	Number of Background Medium Scans Performed							

- **Power On Minutes** indicates the total power on minutes at the time the log page is requested
- **BMS Status** is described in the following table

BMS Status	Description
00h	No scans active
01h	Background medium scan is active
03h-04h	Not supported
05h	Background scan halted due to medium formatted without P-List
06h	Background scan halted due to a vendor-specific cause
07h	Background scan halted due to temperature out of range
08h	Scan suspended until BMS Interval Timer expires

BMS Status	Description
09h - FFh	Reserved

- The **Number of Background Scans Performed** field indicates the total number of back ground scans (i.e. total number of Background Medium Scans PLUS number of Background Prescan) that have been performed over the life of the drive.
- **Medium Scan Progress** is a percent complete indication of the medium scan. The returned value is a numerator that has 65,536 (1 00 00h) as its denominator.
- **Number of Background Medium Scans Performed** field indicates the number of background medium scans that have been performed over the life of the drive.

The following table describes the Medium Scan Parameter structure.

Byte	Bit							
	7	6	5	4	3	2	1	0
0-1	Parameter Code = 0001h - 0800h							
2	DU=0	DS=0	TSD=0	ETC=0	TMC=0		F&L = 11b	
3	Page Length = 14h							
4-7	Power On Minutes							
8	Reassign Status				Sense Key			
9	Additional Sense Code							
10	Additional Sense Code Qualifier							
11	Head				(MSB)	Cylinder		
12-13	(MSB)	Cylinder						(LSB)
14-15	(MSB)	Sector						(LSB)
16-23	LBA							

- **Power On Minutes** indicates the total power on minutes at the time the error was detected.
- **Reassign Status** is set as shown below. Reassignment during the background scan is not supported.

<b>Reassign Status</b>	<b>Description</b>
<b>0h</b>	<b>No reassignment needed</b> This value is not reported, if LOWIR bit is set to 1 in Background Control Mode Page.
<b>1h</b>	<b>Reassignment pending receipt of Reassign command or write command (if auto write reallocation is allowed) from the initiator</b>
<b>02h-4h</b>	<b>Not supported</b>
<b>5h</b>	<b>Error was detected by BGMS, and was successfully rewritten.</b> This value is not reported, if LOWIR bit is set to 1 in Background Control Mode Page.
<b>6h</b>	<b>Error was detected by BGMS, and was successfully reassigned by Application Client. Contains valid data.</b>
<b>7h - Fh</b>	<b>Reserved</b>

**Additional Sense Code and Additional Sense Code Qualifier** provide details about the error detected.

## 18.7.12 Log Sense Page 18

This page contains protocol-specific log parameters.

**Table 84: Log Sense Page 18**

Byte	Bit							
	7	6	5	4	3	2	1	0
0	Page code = 18h							
1	SubPage Code (00h)							
2-3	(MSB) Page Length (D8h) (LSB)							
Protocol-specific log parameters								
4-111	First Protocol-specific log parameter - Primary Port							
112-219	Last Protocol-specific log parameters - Secondary Port							

**Table 85: SAS Log Descriptor**

Byte	Bit							
	7	6	5	4	3	2	1	0
0-1	(MSB) Parameter Code (0001h for primary port; 0002h for secondary) (LSB)							
2	DU (=0)	Obsolete	TSD (=0)	ETC (=0)	TMC (00b)		Format and Linking	
3	Parameter Length (68h)							
4	Reserved				Protocol IDENTIFIER (6h)			
5	Reserved							
6	Generation Code							
7	Number of Phys (01h)							
8	Reserved							
9	PHY IDENTIFIER (00h)							
10	Reserved							
11	SAS Phy Log Descriptor Length (60h)							
12	Reserved	Attached Device Type			Attached Reason			
13	Reason				Negotiated Physical Link Rate			
14	Reserved				Attached SSP Initiator Port	Attached STP Initiator Port	Attached SMP Initiator Port	Reserved
15	Reserved				Attached SSP Target Port	Attached STP Target Port	Attached SMP Target Port	Reserved

16-23	(MSB) SAS Address (the address of the target port) (LSB)
24-31	(MSB) ATTACHED SAS ADDRESS (the address received in the incoming IDENTIFY) (LSB)
32	ATTACHED PHY IDENTIFIER (the phy identifier received in the incoming IDENTIFY)
33-39	Reserved
40-43	(MSB) INVALID DWORD COUNT (LSB)
44-47	(MSB) RUNNING DISPARITY ERROR COUNT (LSB)
48-51	(MSB) LOSS OF DWORD SYNCHRONIZATION (LSB)
52-55	(MSB) PHY RESET PROBLEM (LSB)
56-57	Reserved
58	Phy event Descriptor Length (0Ch)
59	Number of Event Descriptors (04h)
60-62	Reserved
63	Phy Event Source (01h) (Invalid DWORD Count)
64-67	(MSB) Phy Event (LSB)
68-71	(MSB) Peak Value Detector Threshold (00h) (LSB)
72-74	Reserved
75	Phy Event Source (02h) (Running Disparity Error Count)
76-79	(MSB) Phy Event (LSB)

80-83	(MSB)	Peak Value Detector Threshold (00h)	(LSB)
84-86		Reserved	
87		Phy Event Source (03h) (Loss of DWORD Sync)	
88-91	(MSB)	Phy Event	(LSB)
92-95	(MSB)	Peak Value Detector Threshold (00h)	(LSB)
96-98		Reserved	
99		Phy Event Source (04h) (PHY Reset problem)	
100-103	(MSB)	Phy Event	(LSB)
104-107	(MSB)	Peak Value Detector Threshold (00h)	(LSB)

- **Attached Device Type:** set to the value received by this PHY during an Identify Sequence.
- **Attached Reason:** If the phy is a physical phy and a SAS phy or expander phy is attached, then the ATTACHED REASON field indicates the value of the REASON field in the last received IDENTIFY address frame (see Table 30 on page 54) during the identification sequence. If the phy is a physical phy and a SATA phy is attached, then the ATTACHED REASON field shall be set to 0h after the initial Register - Device to Host FIS has been received. If the phy is a virtual phy, then the ATTACHED REASON field shall be set to 0h.
- **Reason:** The REASON field indicates the reason for the last link reset sequence as reported in the last transmitted IDENTIFY address frame. (see Table 30 on page 54). If the phy is a physical phy and a SATA phy is attached, then the REASON field indicates the reason for the link reset sequence. For Reason field, refer Table 31 on page 55.
- **Negotiated PHY Link Rate:** set to the link rate negotiated during last Link Reset Sequence.
  - set to 8h when the PHY is enabled and the negotiated speed is 1.5G
  - set to 9h when the PHY is enabled and the negotiated speed is 3.0G
  - set to Ah when the PHY is enabled and the negotiated speed is 6.0G
- **The GENERATION CODE** field is a one-byte counter that shall be incremented by one by the device server every time the values in this mode page or the SAS-2 Phy mode page (see 10.2.7.7) field values are changed. A GENERATION CODE field set to 00h indicates the generation code is unknown. The device server shall wrap this field to 01h as the next increment after reaching its maximum value (i.e., FFh). The GENERATION CODE field is also contained in the Protocol-Specific Port log page and may be used to correlate phy settings across mode page and log page accesses.
- **Attached Reason:** indicates the value of the REASON field received in the IDENTIFY address frame.
- **Attached Initiator Port bits:** set to the value received by this PHY during an Identify Sequence.
- **Attached Target Port:** set to the value received by this PHY during an Identify Sequence.
- **SAS ADDRESS:** field contains the SAS address *transmitted* by this PHY during an Identify Sequence.
- **Attached SAS ADDRESS:** field contains the SAS address *received* by this PHY during an Identify Sequence.
- **Attached PHY Identifier:** field contains the SAS PHY Identifier *received* by this PHY during an Identify Sequence.



- **INVALID DWORD COUNT:** indicates the number of invalid dwords that have been received outside of phy reset sequences. The count wraps at the maximum value.
- **RUNNING DISPARITY ERROR COUNT:** RUNNING DISPARITY ERROR COUNT increments by one when the port has acquired dword synchronization and detects a transmission word containing a running disparity error at the receiver. When the port has lost dword synchronization, the Running Disparity Error Count is not incremented. The count stops at the maximum value.
- **LOSS OF DWORD SYNCHRONIZATION:** indicates the number of times the phy has lost dword synchronization and restarted the link reset sequence of phy reset sequences. The count wraps at the maximum value.
- **PHY RESET PROBLEM:** indicates the number of times the phy reset sequence has failed due to a failure to gain dword sync in the retry speed match speed negotiation. The count wraps at the maximum value.

## 18.7.13 Log Sense Page 1A

Table 86: Log Sense Page 1A

Byte	Bit								
	7	6	5	4	3	2	1	0	
0	Reserved		Page code = 1Ah						
1	SubPage Code (00h)								
2-3	Page Length (30h)								
4-5	Parameter Code 0001h								
6	DU	Obsolete	TSD	ETC	TMC	TMC	FMT & Linking	FMT & Linking	
7	Parameter Length = 4								
8-11	Accumulated Transitions to Active State								
12-13	Parameter Code 0002h								
14	DU	Obsolete	TSD	ETC	TMC	TMC	FMT & Linking	FMT & Linking	
15	Parameter Length = 4								
16-19	Accumulated Transitions to Idle_A								
20-21	Parameter Code 0003h								
22	DU	Obsolete	TSD	ETC	TMC	TMC	FMT & Linking	FMT & Linking	
23	Parameter Length = 4								
24-27	Accumulated Transitions to Idle_B								
28-29	Parameter Code 0004h								
30	DU	Obsolete	TSD	ETC	TMC	TMC	FMT & Linking	FMT & Linking	
31	Parameter Length = 4								
32-35	Accumulated Transitions to Idle_C								
36-37	Parameter Code 0008h								
38	DU	Obsolete	TSD	ETC	TMC	TMC	FMT & Linking	FMT & Linking	
39	Parameter Length = 4								
40-43	Accumulated Transitions to Standby_Z								
44-45	Parameter Code 0009h								
46	DU	Obsolete	TSD	ETC	TMC	TMC	FMT & Linking	FMT & Linking	
47	Parameter Length = 4								
48-51	Accumulated Transitions to Standby_Y								

## 18.7.14 Log Sense Page 2F

This page contains SMART Status and Temperature Reading.

**Table 87: Log Sense Page 2F**

Byte	Bit							
	7	6	5	4	3	2	1	0
0	Reserved		Page code = 2Fh					
1	Reserved							
2-3	PageLength = 8							
4-5	Parameter Code = 0000h							
6	DU = 0	DS = 0	TSD = 0	ETC = 0	TMC = 0		F&L = 11b	
7	Parameter Length = 04h							
8	SMART Sense Code Byte							
9	SMART Sense Qualifier							
10	Most Recent Temperature Reading							
11	Vendor HDA Temperature Trip Point							

## 18.7.15 Log Sense Page 30

This page contains Performance Counters.

**Table 88: Log Sense Page 30**

Byte	Bit							
	7	6	5	4	3	2	1	0
0	Reserved		Page code = 30h					
1	Reserved							
2-3	Page Length = 0030h							
4-5	Parameter Code = 0000h							
6	DU = 0	DS = 0	TSD = 0	ETC = 0	TMC = 0		F&L = 00b	
7	Parameter Length = 2Ch							
8-9	Zero Seeks							
10-11	Seeks > = to 2/3							
12-13	Seeks > = 1/3 and < 2/3							
14-15	Seeks > = 1/6 and < 1/3							
16-17	Seeks > = 1/12 and < 1/6							
18-19	Seeks > 0 and < 1/12							
20-23	Reserved = 0							
24-25	Overrun Counter							
26-27	Under run Counter							
28-31	Device Cache Full Read Hits							
32-35	Device Cache Partial Read Hits							
36-39	Device Cache Write Hits							
40-43	Device Cache Fast Writes							
44-47	Device Cache Read Misses							
48-51	Reserved = 0							

Page 30h returns performance counter information. This includes seek counters and buffer overrun/under run counters.

The appropriate seek counter is incremented once during execution of Pre-Fetch, Read, Verify, Write, Write and Verify, Write Same, and Seek commands.

Buffer Overrun conditions are detected during Read commands.

Buffer Underrun conditions are detected during Verify with ByteChk=1, Write, Write and Verify, and Write Same commands.

Only one seek counter is incremented for each of these commands and the counter is incremented only once per command. The length of the initial seek that is required to access the first Logical Block specified for the SCSI command determines which seek counter is incremented. The Zero Seek counter is incremented if a seek is not required or if only a head switch is

required to access the first Logical Block. After the initial seek, no further counter incrementing is performed for that command.

**Note:** The length of a seek as reported in page 30 may differ from expected results. The reason for this is that the drive executes Idle Time Functions between operations of the drive. The seek operations that occur in Idle Time Functions are not directly entered into page 30 seek counters but they change the length of the following seek. This is because after the Idle Time Function is completed, the heads will not necessarily be in the same position as they were at the completion of the previous command.

A buffer overrun or under run condition occurs when the Initiator does not transfer data to or from the Target data buffer fast enough to keep up with reading or writing the media. The buffer overrun counter is incremented during operations that require a Data In phase when a buffer full condition prevents the continued transfer of data from the media to the data buffer. The buffer under run counter is incremented during operations that require a Data Out phase when a buffer empty condition prevents the start or continuation of a data transfer from the data buffer to the media (or a data transfer from the media for a Verify command with BytChk=1).

Buffer Overrun conditions are detected during the following SCSI commands:

- READ (6)
- READ (10)

Buffer Under Run conditions are detected during the following SCSI commands:

- VERIFY WITH BytChk=1
- VERIFY (16) WITH BytChk=1
- WRITE (6)
- WRITE (10)
- WRITE AND VERIFY
- WRITE AND VERIFY (16)
- WRITE SAME
- WRITE SAME (16)
- **ZERO SEEKS**

The number of times no seek was required. The operation may have resulted in a head switch.

- **SEEKS  $\geq$  2/3 DISK**

The number of seeks equal to or greater than 2/3 of the disk.

- **SEEKS  $\geq$  1/3 AND  $<$  2/3 DISK**

The number of seeks equal to or greater than 1/3 and less than 2/3 of the disk.

- **SEEKS  $\geq$  1/6 AND  $<$  1/3 DISK**

The number of seeks equal to or greater than 1/6 and less than 1/3 of the disk.

- **SEEKS  $\geq$  1/12 AND  $<$  1/6 DISK**

The number of seeks equal to or greater than 1/12 and less than 1/6 of the disk.

- **SEEKS  $>$  0 AND  $<$  1/12 DISK**

The number of seeks less than 1/12 of the disk.

- **OVERRUN COUNTER**

The number of times that data was available to be transferred from the media but the device buffer still contained data that had not been retrieved by the Initiator. Consequently, the disk had to take additional revolutions until the buffer was available to accept data.

- **UNDER RUN COUNTER**

The number of times that the drive was ready to transfer data to its disk (on a write), but its buffer was empty (i.e., had not been filled by the Initiator), thus the disk was forced to take extra revolutions.

- **DEVICE CACHE FULL READ HITS**

The number of times that all of the data requested by the read operation was obtained from the device read or write cache.

- **DEVICE CACHE PARTIAL READ HITS**

The number of times that a portion, but not all, of the data requested by the read operation was obtained from the device read or write cache. A physical operation to the device media was required to obtain the remaining data.

- **DEVICE CACHE WRITE HITS**

The number of times that the data associated with a write operation replaces, or is combined with, existing data in the device write cache, thereby eliminating a write operation.

- **DEVICE CACHE FAST WRITES**

The number of times that space was available in the device write cache for the data associated with a write operation and a response was returned immediately.

- **DEVICE CACHE READ MISSES**

The number of times that none of the data requested by the read operation was obtained from the read cache.

The statistics reported by this page are lost on a self-initiated reset or when the Drive is powered off. Even though the DS field equals zero, the parameters on this page are not savable.

## 18.7.16 Log Sense Page 37

This page contains a series of miscellaneous data counters including information about predictive failure analysis occurrences.

**Table 89: Log Sense Page 37**

Byte	Bit							
	7	6	5	4	3	2	1	0
0	Reserved		Page code = 37h					
1	Reserved							
2-3	Page Length = 0030h (48)							
4-5	Parameter Code = 0000h							
6	DU=0	DS=0	TSD=0	ETC=0	TMC = 0		F&L = 00b	
7	Parameter Length = 2Ch							
8	(MSB)							
-	Power on Hours (hours only)							
11	(LSB)							
12	(MSB)							
-	Total Bytes Read							
19	(LSB)							
20	(MSB)							
-	Total Bytes Written							
27	(LSB)							
28	Max Drive Temp (degrees Celsius)							
29 - 30	(MSB)							
	GList Size							
	(LSB)							
31	Number of Information Exceptions							
32	MED EXC	HDW EXC	Reserved = 0					
33 - 40	Total Read Commands							
41 - 48	Total Write Commands							
49	Reserved = 0							
50-51	Flash Correction Count							

The **Power on Hours** field specifies the total time the drive has been powered on in hours only.

The **Max. Drive Temperature** field specifies the maximum temperature, in degrees Celsius, the drive has ever reached.

The **Glist Size** field gives the total number of LBAs that have been reassigned on the drive.

**The Number of Information Exceptions** field gives the number of Information Exceptions during the life of the drive and not the number of Information Exceptions that have been reported. The number of reported Information Exceptions may be less due to the settings of Mode Page 0x1C. NOTE: This field does not include occurrences of any Information Exception Warnings.

If set, the **Media Exception and Hardware Exception** bits indicate that an Information Exception has occurred during the life of the drive. These flags are set during an Information Exception that may or may not coincide with the reporting of an Information Exceptions as mentioned above.

**Total Read Commands** counter is incremented for each Read (6) and Read (10) command received.

**Total Write Commands** counter is incremented for each Write (6), Write (10), Write Verify and Write Verify (16) command received.

**Flash Correction Count** is incremented each time ECC correction is applied to data stored in Flash ROM.



## 18.8 MODE SELECT (15)

**Table 90: Mode Select (15)**

Byte	Bit							
	7	6	5	4	3	2	1	0
0	Command Code = 15h							
1	Reserved = 0			PF=1	Reserved = 0			SP
2	Reserved = 0							
3								
4	Parameter List Length							
5	VU = 0		Reserved = 0			FLAG	LINK	

The MODE SELECT (15) command provides a means for the Initiator to specify LUN or device parameters to the Target. It also allows an Initiator to specify options the Target uses in error recovery, caching, and formatting.

There is a single set of Mode Page parameters shared by all Initiators.

- **PF** A PF (Page Format) bit value of one indicates that the data sent by the Initiator after the Mode Select Header and the Block Descriptor, if any, complies to the Page Format. The Target ignores this field since it only accepts mode parameters in the Page Format.
- **SP** Save Pages. This indicates
  - 0 The drive shall not save the pages sent during the Data Out phase but will use them for all following commands until the power is removed, a reset is received, or a new MODE SELECT command is received.
  - 1 The drive will save the data in the reserved area of the disk. It will be used for all the following commands until another MODE SELECT command is issued. This information is maintained over a power cycle or reset of the drive.
- **Parameter List Length** This specifies the number of bytes to be sent from the Initiator. A parameter list length of zero suppresses data transfer and is not considered an error.

The MODE SELECT parameter list contains a 4-byte header followed by zero or one block descriptor followed by zero or more pages. The pages that are valid with this command are defined in the addendum under the heading **Mode Select Data**, as they vary with the drive model.

### Application Note

The Initiator should issue a MODE SENSE command requesting all Changeable values (see PCF field in byte two of the CDB in) prior to issuing a MODE SELECT command. This is necessary to find out which pages are implemented by the drive and the length of those pages. In the Pages of the MODE SENSE command the drive will return the number of bytes supported for each Page. The Page Length set by the Initiator in the MODE SELECT command must be the same value as returned by the drive in MODE SENSE Page Length. If not, the drive will return *Check Condition* status with sense key of *Illegal Request*.

**Note:** If an Initiator sends a MODE SELECT command that changes any parameters that apply to other Initiators, the drive shall generate an unit attention condition for all Initiators except for the one that issued the MODE SELECT command. The drive shall set the additional sense code to *Parameters Changed* (2Ah).

## 18.9 MODE SELECT (55)

Table 91: Mode Select (55)

Byte	Bit							
	7	6	5	4	3	2	1	0
0	Command Code = 55h							
1	Reserved = 0			PF=1	Reserved = 0			SP
2-6	Reserved = 0							
7-8	(MSB) Parameter List Length (LSB)							
9	VU = 0		Reserved = 0			FLAG	LINK	

The MODE SELECT (55) command provides a means for the Initiator to specify LUN or device parameters to the Target. See the MODE SELECT (15) command for a description of the fields in this command.

## 18.10 MODE SENSE (1A)

Table 92: Mode Sense (1A)

Byte	Bit							
	7	6	5	4	3	2	1	0
0	Command Code = 1Ah							
1	Reserved= 0			RSVD	DBD	Reserved = 0		
2	PCF		Page Code					
3	Subpage Code							
4	Allocation Length							
5	VU = 0		Reserved = 0			FLAG	LINK	

The MODE SENSE (1A) command provides a means for the drive to report various device parameters to the Initiator. It is the complement to the MODE SELECT command.

If the **DBD** (Disable Block Descriptor) bit is zero, the Target will return a Block Descriptor. If the DBD bit is set to 1, the Target will not return a Block Descriptor.

**Allocation Length** indicates the maximum number of bytes that the Initiator has set aside for the DATA IN phase. A value of zero is not considered an error. If the allocation length is smaller than the amount available, that portion of the data up to the allocation length will be sent. This may result in only a portion of a multi-byte field being sent.

**Page Control Field:** PCF (Page Control Field) defines the type of Page Parameter values to be returned.

### PCF Meaning

**0 0 Report current values.** The drive returns the current values under which the logical unit is presently configured for the page code specified. The current values returned are

1. Initially following power-up but before the media is accessed, the default values become current. Once the media can be accessed, the saved values are read from the Reserved Area and become current.
2. The parameters set in the last successful MODE SELECT command.
3. The saved values if a MODE SELECT command has not been executed since the last power-on, hard RESET condition, or TARGET RESET message.

Following the completion of start-up, execution of the MODE SELECT command can modify the current values.

**Note:** Those parameters associated with format are not considered current and are not saved until the successful completion of a FORMAT UNIT command.

In addition, the current values take on the saved values after a reset if the parameters were saved. If the Page Code is 3Fh, then all pages implemented by the Target are returned to the Initiator with fields and bit values set to current values.

If the Page Code is not 3Fh, the page defined by the Page Code, if supported by the Target, is returned with fields and bits set to current values.

**Note:** The drive will not process the MODE SELECT command until the completion of spin-up. Therefore, the Initiator cannot modify the current values prior to the saved values being read in.

**0 1 Report changeable value.** The drive returns the changeable values for the page code specified. The page requested is returned containing information that indicates which fields are changeable. All bits of parameters that are changeable shall be set to one. Parameters that are *defined by the drive* shall be set to zero. If any part of a field is changeable, all bits in that field shall be set to one.

**Note:** For a value field such as the buffer ratios of page 2 the bit field will not indicate the range of supported values but rather that the field is supported.

**1 0 Report default value.** The drive returns the default values for the page code specified. The parameters not supported by the drive are set to zero.

**1 1 Report saved value.** The drive returns the saved value for the page code specified.

Saved values are one of the following:

- the values saved as a result of MODE SELECT command
- identical to the default values
- zero when the parameters are not supported

The Page Length byte value of each page returned by the drive indicates up to which fields are supported on that page.

**Page Code:** This field specifies which page or pages to return. Page code usage is defined in the figure below.

**Table 93: Page Code Usage**

Page Code	Description
00h - 1Ch	Return specific page, if supported.
3Fh	Return all supported pages.

If a Page Code of 3Fh is used, MODE SENSE returns the pages in ascending order with one exception. Page 0 is always returned last in response to a MODE SENSE command.

If an unsupported page is selected, the command is terminated with a CHECK CONDITION status and available sense of ILLEGAL REQUEST/INVALID FIELD IN CDB.

**Subpage Code:** This field specifies the subpage to return, and may be set to a specific page, or to FFh for all supported subpages.

### 18.10.1 Mode Parameter List

The mode parameter list contains a header followed by zero or one block descriptors followed by zero or more variable length pages.

#### 18.10.1.1 Header

The header used for the 6-byte CDB is defined below.

**Table 94: Mode parameter header (6)**

Byte	Bit							
	7	6	5	4	3	2	1	0
0	Mode Data Length							
1	Medium Type = 0							
2	WP=0	Reserved=0	DPOFUA = 1		Reserved = 0			
3	Block Descriptor Length (= 0 or 8)							

The header used for the 10-byte CDB is defined below.

**Table 95: Mode parameter header (10)**

Byte	Bit							
	7	6	5	4	3	2	1	0
0 - 1	(MSB) Mode Data Length							(LSB)
2	Medium Type = 0							
3	WP=0	Reserved=0		DPOFUA =1	Reserved = 0			
4	Reserved = 0							LongLBA
5	Reserved = 0							
6 - 7	(MSB) Block Descriptor Length							(LSB)

- **Mode Data Length.** When using the MODE SENSE command, the mode data length field specifies the length in bytes of the following data that is available to be transferred. The mode data length does not include the length byte itself. When using the MODE SELECT command, this field is reserved.
- **Medium Type** field is always set to zero in the drive (Default Medium Type).
- **WP.** When used with the MODE SELECT command, the Write Protect (WP) bit is reserved. When used with the MODE SENSE command, a Write Protect (WP) bit of zero indicates that the medium is write enabled.
- **DPOFUA** bit value of 1 indicates that the Target supports the FUA and DPO bits in the Read and Write Commands.
- **LONGLBA** bit value of 0 indicates that any following Block Descriptor uses the Short LBA Block Descriptor format. A LONGLBA bit value of 1 indicates that any following Block Descriptor uses the Long LBA Block Descriptor format
- **Block Descriptor Length** specifies the length in bytes of the block descriptor. Values of 0, 8, and 16 are supported by the Target, respectively corresponding to an absent Block Descriptor, a single Short LBA Block Descriptor, and a single Long LBA Block Descriptor.

**Note:** DPOFUA is ignored during Mode Select command processing although the SCSI Standard states that it is reserved during Mode Select. Ignoring it allows the Mode Sense Parameter List for the byte containing this bit to be re-used as a Mode Select Parameter List.

### 18.10.1.2 Block Descriptors

**Table 96: Short LBA Mode Parameter Block Descriptor**

Byte	Bit							
	7	6	5	4	3	2	1	0
0 - 3	(MSB) Number of Blocks							(LSB)
4	Reserved = 0							
5 - 7	(MSB) Block Length							(LSB)

**Table 97: Long LBA Mode Parameter Block Descriptor**

Byte	Bit							
	7	6	5	4	3	2	1	0
0 - 7	(MSB) Number of Blocks							(LSB)
8-11	Reserved = 0							
12-15	(MSB) Block Length							(LSB)

The Block descriptor provides formatting information about the Number of Blocks (user addressable) to format at the specified Block Length.

- Number of Blocks

When used with the MODE SELECT command, the **Number of Blocks** field must be

- Zero to indicate not to change available blocks
- 0xFFFFFFFF (Short LBA) or 0xFFFFFFFFFFFFFFFF (Long LBA) to indicate all available blocks
- The exact number of blocks in the data area of the drive, which can be obtained with the MODE SENSE
- The number of blocks less than exact one, in order to **CLIP** the number of blocks

Any other value is invalid and causes the command to fail with *Check Condition* status.

When returned by the MODE SENSE command, the field contains the exact number of blocks.

- Block Length

The **Block Length** field reflects the number of bytes of user data per sector (not including any protection information). When used with the MODE SELECT command, the **Block Length** field must contain a value from 512 to 528 (8 bytes step) or zero. Otherwise the drive will terminate the command with *Check Condition* status.

A FORMAT UNIT command is required to cause these parameters to become current only if the block length parameter is different from the current block length.

### 18.10.1.3 Page Descriptor

**Table 98: Mode Parameter Page Format**

<b>Byte 0</b>	<b>PS</b>	<b>SPF</b>	<b>Page Code</b>
<b>Byte 1</b>	<b>Page Length</b>		
<b>Byte 2-n</b>	<b>Mode Parameters</b>		

Each mode page contains a page code, a page length, and a set of mode parameters.

When using the MODE SENSE command, a Parameter Savable (PS) bit of one indicates that the mode page can be saved by the drive in the reserved area of the drive. A PS bit of zero indicates that the supported parameters cannot be saved. When using the MODE SELECT command, the PS bit is reserved (zero).

**SPF** (Sub-Page Format) is set to zero to indicate the short page format is used. The bit is set to one to indicate the long format is used, supporting sub-pages. The drive supports the following mode page codes:

**Table 99: Mode Parameter Page Format**

<b>Page</b>	<b>Description</b>	<b>PS</b>
<b>00</b>	<b>Vendor Unique Parameters</b>	<b>1</b>
<b>01</b>	<b>Read-Write Error Recovery Parameters</b>	<b>1</b>
<b>02</b>	<b>Disconnect/Reconnect Control Parameters</b>	<b>1</b>
<b>03</b>	<b>Format Device Parameters</b>	<b>0</b>
<b>04</b>	<b>Rigid Disk Geometry Parameters</b>	<b>0</b>
<b>07</b>	<b>Verify Error Recovery Parameters</b>	<b>1</b>
<b>08</b>	<b>Caching Parameters</b>	<b>1</b>
<b>0A</b>	<b>Control Mode Page</b>	<b>1</b>
<b>0C</b>	<b>Notch Parameters</b>	<b>1</b>
<b>19</b>	<b>Port Control Page</b>	<b>1</b>
<b>1A</b>	<b>Power Control Parameters</b>	<b>1</b>
<b>1C</b>	<b>Informational Exceptions Control</b>	<b>1</b>

The page length field specifies the length in bytes of the mode parameters that follow. If the Initiator does not set this value to the value that is returned for the page by the MODE SENSE command, the drive will terminate the command with *Check Condition* status.

## 18.10.2 Mode Page 00 (Vendor Unique Parameters)

Table 100: Vendor Unique Parameters - Page 00

Byte	Bit								Default
	7	6	5	4	3	2	1	0	
0	PS	0	Page Code = 00h						80h
1	Page Length = 0Eh								0Eh
2	Reserved				MRG	Reserved		Ignored	00h
3	Reserved	VGMDE	Reserved			RRNDE	Reserved	00h	
4	Reserved								00h
5	Reserved			FDD	Reserved		CAEN	Ignored	02h
6	IGRA	AVERP	Reserved		OCT (high nibble)			00h	
7	Overall Command Timer (low byte)								00h
8	Reserved								00h
9	Temperature Threshold								00h
10	Command Aging Limit (Hi byte)								00h
11	Command Aging Limit (Low byte)								30h
12	Read Reporting Threshold								16h
13	Write Reporting Threshold								14h
14	DRRT	Ignored			FFMT	Ignored		00h	
15	Ignored	Reserved	FCERT	Ignored	Reserved	Ignored	Reserved	00h	

Fields marked in the table as 'Ignored' are not used or checked by the drive. They will be initialized to zero but can be set as desired for compatibility with older drives.

- **MRG** (Merge Glist into Plist) bit is set to 1 for merging the Glist entries into the Plist during FORMAT UNIT command.
- **VGMDE** (Veggie Mode) bit set to 1 will cause the drive to execute random self-seeks. To enable this mode, the initiator must perform the mode select to set the bit while the drive is spinning, then Stop Unit, then Start Unit. VGMDE set to 0 disables the self-seeks (normal operation).
- **RRNDE** (Report Recovered Non Data Errors) bit controls the reporting of recovered Non Data Errors when the PER bit is set. If RRNDE is set, recovered Non Data Errors are reported. If the RRNDE bit is not set, then recovered Non Data Errors are not reported.
- **FDD** (Format Degraded Disable) controls the reporting of Format Degraded sense data for Test Unit Ready commands when the drive is in a format degraded state. When the FDD bit is one, Format Degraded sense data will not be reported for a Test Unit Ready command. When the FDD bit is zero, Format Degraded sense data will be reported for Test Unit Ready commands when the drive is in a format degraded state. This bit does not affect the reporting of Format Degraded conditions for any media access commands.
- **CAEN** (Command Aging Enable) When set this bit causes the Command Age Limit timer to be used to avoid commands waiting in the command queue for an indefinite period. When commands have been in the queue for a period of time greater than the timer limit they will be reordered to be executed on a first come first served basis. When this bit is reset, commands are always executed based on the queue reordering rules.
- **IGRA** (Ignore Reassigned LBA) bit works in conjunction with the RC bit (Mode Page 01h, byte 2, bit 4). The main purpose of this bit is to avoid undesirable read processing time delays due to reassigned LBA processing for continuous data availability requirements such as Audio Visual applications. If IGRA is set to one and RC is set to one, out-of-



line reassigned LBAs will not be processed. If IGRA is set to one and RC is set to zero, or if IGRA is set to zero, reassigned LBAs will be processed normally.

- **AVERP** (AV ERP Mode) bit is set to one in order to specify maximum retry counts during Read DRP. When AVERP bit is set to one, the maximum retry counts for read operations is specified by Read Retry Count (Mode Page 1 Byte 3). AVERP bit is set to zero to specify that the drive shall process read DRP up to the default maximum retry count when Read Retry Count is set to a non-zero value.
- **OCT** (Overall Command Timer) controls the maximum command execution time, from receipt by the drive until status is returned. If the command is unable to complete in the specified amount of time, it will be aborted with Check Condition status, Aborted Command sense key. The Overall Command Timer does not alter the behavior of the Command Aging Limit or Recovery Time Limit. Each unit of this timer is 50 milliseconds. Setting the value to zero disables the feature.
- **Temperature Threshold** Temperature Threshold specifies the threshold value in degrees Celsius for the thermal sensor Information Exception Warning; the reporting of which is controlled by Mode Page 0x1C. A value of 0 selects the default value (85 degrees Celsius).
- **Command Aging Limit** This value controls the maximum time a command should wait in the command queue when the CAEN bit is set. Each unit of this timer is 50 ms.
- **Read Reporting Threshold** specifies the recovery step that must be exceeded to report recovered data errors during read operations when PER=1. For example, if the Read Reporting Threshold is set to 22, recovered read errors will be reported starting at recovery step 23
- **Write Reporting Threshold** specifies the recovery step that must be exceeded to report recovered data errors during write operations when PER=1. For example, if the Write Reporting Threshold is set to 20, recovered write errors will be reported starting at recovery step 21.
- **DRRT** (Disable Restore Reassign Target) bit disables the reading and restoration of the target LBA during a Reassign Blocks command. If the DRRT bit is zero, the reassign command attempts to restore the target LBA's data. If the data cannot be restored, the target LBA is reassigned and written with a data pattern of all 00s. If the DRRT bit is one, no attempt is made to restore the target LBA.
- **FFMT** (Fast Format Enable) bit allows the formatting of the drive without any writes to the customer media. All format operations are allowed including changing block sizes and manipulating defects. The drive will operate normally after a fast format with the following caveat: since no data is written to any customer data blocks as a result of a Fast Format operation, there is a possibility that a read attempt to any particular block (without having previously written to that block) will result in an unrecoverable data error. This will most likely happen if the block size is changed as every LBA will contain data of an incorrect length and apparently an incorrect starting point. It is also possible to generate an uncorrectable data error without changing block sizes if the defect list is shortened and previously bad blocks become visible in the customer address space. Of course ALL DATA ON THE DRIVE WILL BE LOST as the result of any format operation and so any attempt to read blocks which have not been written to will result in unpredictable behavior.
- **FCERT** (Format Certification) bit determines whether the certification step will be performed during a Format Unit command. FCERT bit set to 0 disables certification. FCERT bit set to 1 enables the certification step.

### 18.10.3 Mode Page 01 (Read/Write Error Recovery Parameters)

Table 101: Mode Page 01 (Vendor Unique Parameters)

Byte	Bit								Default	
	7	6	5	4	3	2	1	0		
0	PS	0	Page Code = 01h							81h
1	Page Length = 0Ah								0Ah	
2	AWRE	ARRE	TB	RC	EER=0	PER	DTE	DCR	C0h	
3	Read Retry Count								01h	
4	Obsolete = 0								00h	
5	Obsolete = 0								00h	
6	Obsolete = 0								00h	
7	Reserved								00h	
8	Write Retry Count								01h	
9	Reserved								00h	
10	(MSB) Recovery Time Limit (LSB)								00h	
11										

The Read-Write recovery parameters that will be used during any command that performs a read or write operation to the medium are as follows:

- **AWRE** Automatic Write Reallocation Enabled bit, set to zero indicates that the drive shall not perform automatic reallocation of defective data blocks during write operations. An AWRE bit set to one indicates that the drive shall perform automatic reallocation of defective data blocks during write operations.
- **ARRE** Automatic Read Reallocation Enabled bit, set to zero indicates that the drive shall not perform automatic reallocation of defective data blocks during read operations. ARRE bit set to one indicates that the drive shall perform automatic reallocation of defective data blocks during read operations.
- **TB** Transfer Block bit, set to one indicates that a data block that is not recovered within the recovery limits specified shall be transferred to the Initiator before *Check Condition* status is returned. A TB bit set to zero indicates that such a data block shall not be transferred to the Initiator. Data blocks that can be recovered within the recovery limits are always transferred regardless of the value of the bit.
- **RC** Read Continuous bit, set to one requests the Target to transfer the entire requested length of data without adding delays that would increase or ensure data integrity. This implies that the Target may send erroneous data. This bit has priority over all other error control bits (PER, DTE, DCR, TB). RC set to zero indicates normal interpretation of PER, DTE, DCR, and TB values. The RC bit setting is used by the Target when reporting errors associated with the transfer of the Initiator's data for the Read commands interpretation of PER, DTE, DCR, and TB values. The RC bit applies only to READ commands.

**Note:** The Target implementation of the RC option is to disable error detection of the data fields but continue normal error detection and recovery for errors occurring in the servo field. If a servo field failure occurs, normal DRP could result in considerable recovery action, including proceeding through all levels of DRP.

- **EER** an Enable Early Recovery bit, **must be set to zero**, indicating that the drive shall use an error recovery procedure that minimizes the risk of misdetection or miscorrection during the data transfer. Data shall not be fabricated.

- **PER** a Post Error bit, is set to one to indicate that the drive reports recovered errors.
- **DTE** (Data Terminate on Error) bit set to one specifies that data transfer will be halted when the first recovered error is encountered. PER must be set to one when DTE is set to one. DTE set to zero will cause data transfer to continue when recovered errors are encountered.
- **DCR** a Disable Correction bit, is set to one to indicate that Error Correction Code is not used for data error recovery. A DCR bit of zero indicates that LDPC is applied to recover the data.
- **Read Retry Count** sets a limit on the amount of DRP passes in which the Target attempts to recover read errors. A value of zero disables all data recovery procedures. When AVERP bit (Mode Page 0 Byte 6 Bit 6) is zero, a value of non-zero in Read Retry Count enables all steps of DRP. When AVERP bit is one, the number in Read Retry Count sets the maximum retry count of DRP.
- **Write Retry Count** sets a limit on the amount of DRP passes in which the Target attempts to recover write errors. A value of zero disables all data recovery procedures.
- **Recovery Time Limit** indicates the period in 1 millisecond increments for the maximum recovery time of a single LBA. The value must be from 40 ms to 65535 ms (65.5 seconds). The granularity of the timer is 50 ms. If an LBA is not able to be recovered within the limit, a Check Condition will be returned. The Recovery Time Limit will not be applied to Writes when WCE=1. A value of zero disables the timer.

The following summarizes valid modes of operation. If an illegal mode is set, the MODE SELECT command will complete successfully but the action of the drive when an error occurs is undefined.

**PER DTE DCR TB DESCRIPTION**

- 0 0 0 0** Retries and Error Correction are attempted. Recovered or corrected data (if any) or both are transferred with no *Check Condition* status at the end of the transfer.

  - no err** The transfer length is exhausted.
  - soft err** The transfer length is exhausted. Transferred data includes blocks containing recovered errors.
  - hard err** Data transfer stops when an unrecoverable error is encountered. The unrecoverable block is not transferred to the Initiator. The drive then creates the *Check Condition* status with the appropriate sense key.
  
- 0 0 0 1** Retries and Error Correction are attempted. Recovered or corrected data (if any) or both are transferred with no *Check Condition* status at the end of the transfer.

  - no err** The transfer length is exhausted.
  - soft err** The transfer length is exhausted. Transferred data includes blocks containing recovered errors.
  - hard err** Data transfer stops when an unrecoverable error is encountered. The unrecoverable block is transferred to the Initiator. The drive then creates the *Check Condition* status with the appropriate sense key.
  
- 0 0 1 0** Retries are attempted but no error correction (LDPC) is applied. Recovered data (if any) are transferred with no *Check Condition* status at the end of the transfer.

  - no err** The transfer length is exhausted.
  - soft err** The transfer length is exhausted. Transferred data includes blocks containing recovered errors.
  - hard err** Data transfer stops when an unrecoverable error is encountered. The unrecoverable block is not transferred to the Initiator. The drive then creates the *Check Condition* status with the appropriate sense key.
  
- 0 0 1 1** Retries are attempted but no error correction (LDPC) is applied. Recovered data (if any) are transferred with no *Check Condition* status at the end of the transfer.

  - no err** The transfer length is exhausted.
  - soft err** The transfer length is exhausted. Transferred data includes blocks containing recovered errors.
  - hard err** Data transfer stops when an unrecoverable error is encountered. The unrecoverable block is transferred to the Initiator. The drive then creates the *Check Condition* status with the appropriate sense key.
  
- 0 1 0 0** Illegal Request-DTE must be zero when PER is zero.
- 0 1 0 1** Illegal Request-DTE must be zero when PER is zero.
- 0 1 1 0** Illegal Request-DTE must be zero when PER is zero.
- 0 1 1 1** Illegal Request-DTE must be zero when PER is zero.
- 1 0 0 0** The highest level error is reported at the end of transfer. Retries and error correction are attempted. Recovered or corrected data (if any) or both are transferred with *Check Condition* status and *Recovered Error* sense key set at the end of the transfer.

  - no err** The transfer length is exhausted.
  - soft err** The transfer length is exhausted. Transferred data includes blocks containing recovered errors. The information byte in the sense data will contain the LBA of the last recovered error.
  - hard err** Data transfer stops when an unrecoverable error is encountered. The unrecoverable block is not transferred to the Initiator. The drive then creates the *Check Condition* status with the appropriate sense key.

- 1 0 0 1** The highest level error is reported at the end of transfer. Retries and error correction are attempted. Recovered or corrected data (if any) or both are transferred with *Check Condition* status and *Recovered Error* sense key set at the end of the transfer.
- no err** The transfer length is exhausted.
  - soft err** The transfer length is exhausted. Transferred data includes blocks containing recovered errors. The information byte in the sense data will contain the LBA of the last recovered error.
  - hard err** Data transfer stops when an unrecoverable error is encountered. The unrecoverable block is transferred to the Initiator. The drive then creates the *Check Condition* status with the appropriate sense key.
- 1 0 1 0** The highest level error is reported at the end of transfer. Retries are attempted but LDPC is not applied. Recovered or corrected data (if any) or both are transferred with *Check Condition* status and *Recovered Error* sense key set at the end of the transfer.
- no err** The transfer length is exhausted.
  - soft err** The transfer length is exhausted. Transferred data includes blocks containing recovered errors. The information byte in the sense data will contain the LBA of the last recovered error.
  - hard err** Data transfer stops when an unrecoverable error is encountered. The unrecoverable block is not transferred to the Initiator. The drive then creates the *Check Condition* status with the appropriate sense key.
- 1 0 1 1** The highest level error is reported at the end of transfer. Retries and error correction are attempted. Recovered or corrected data (if any) or both are transferred with *Check Condition* status and *Recovered Error* sense key set at the end of the transfer.
- no err** The transfer length is exhausted.
  - soft err** The transfer stops on the first soft error detected. The information in the sense data shall contain the LBA of the block in error.
  - hard err** Data transfer stops on the unrecoverable error. The unrecoverable error block is not returned to the Initiator. The drive then creates the *Check Condition* status with the appropriate sense key.
- 1 1 0 0** The highest level error is reported at the end of transfer. Retries and error correction are attempted. Recovered or corrected data (if any) or both are transferred with *Check Condition* status and *Recovered Error* sense key set at the end of the transfer.
- no err** The transfer length is exhausted.
  - soft err** The transfer stops on the first soft error detected. The information in the sense data shall contain the LBA of the block in error.
  - hard err** Data transfer stops on the unrecoverable error. The unrecoverable error block is not returned to the Initiator. The drive then creates the *Check Condition* status with the appropriate sense key.
- 1 1 0 1** The highest level error is reported at the end of transfer. Retries and error correction are attempted. Recovered or corrected data (if any) or both are transferred with *Check Condition* status and *Recovered Error* sense key set at the end of the transfer.
- no err** The transfer length is exhausted.
  - soft err** The transfer stops on the first soft error detected. The information in the sense data shall contain the LBA of the block in error.
  - hard err** Data transfer stops on the unrecoverable error. The unrecoverable error block is returned to the Initiator. The drive then creates the *Check Condition* status with the appropriate sense key.

- 1 1 1 0 The highest level error is reported at the end of transfer. Retries are attempted but LDPC is not applied. Recovered data are transferred with *Check Condition* status and *Recovered Error* sense key set at the end of the transfer.
- no err** The transfer length is exhausted.
  - soft err** The transfer stops on the first soft error detected. The recovered error block is returned to the initiator. The information in the sense data shall contain the LBA of the block in error.
  - hard err** Data transfer stops on the unrecoverable error. The unrecoverable error block is not returned to the Initiator. The drive then creates the *Check Condition* status with the appropriate sense key.
- 1 1 1 1 The highest level error is reported at the end of transfer. Retries are attempted but LDPC in not applied. Recovered or corrected data (if any) or both are transferred with *Check Condition* status and *Recovered Error* sense key set at the end of the transfer.
- no err** The transfer length is exhausted.
  - soft err** The transfer stops on the first soft error detected. The information in the sense data shall contain the LBA of the block in error.
  - hard err** Data transfer stops on the unrecoverable error. The unrecoverable error block is returned to the Initiator. The drive then creates the *Check Condition* status with the appropriate sense key.

## 18.10.4 Mode Page 02 (Disconnect/Reconnect Parameters)

Table 102: Mode Page 02 (Disconnect/Reconnect Parameters)

Byte	Bit								Default
	7	6	5	4	3	2	1	0	
0	PS	0	Page Code = 02h						82h
1	Page Length = 0Eh								0Eh
2	Read Buffer Full Ratio								00h
3	Write Buffer Empty Ratio								00h
4-5	(MSB)	Bus Inactivity Time Limit						(LSB)	00h
6-7	Disconnect Time Limit = 0								00h
8-9	(MSB)	Maximum Connect Time Limit						(LSB)	00h
10-11	(MSB)	Maximum Burst Size						(LSB)	00h
12-13	Reserved = 0								00h
14-15	First Burst Size = 0								00h

The disconnect/reconnect page provides the Initiator with the means to tune the performance of the SAS Link.

The drive uses the disconnect/reconnect parameters to control when it attempts to regain control of the link during READ (operation code 08h and 28h) and WRITE (0Ah, 2Ah and 2E).

- **Read Buffer Full Ratio** is the numerator of a fraction whose denominator is 256. The fraction indicates how full the drive data buffer should be before attempting to re-arbitrate for the link. If the ratio is set to 0h, the target will calculate and use an optimal ratio based on the negotiated transfer rate.
- **Bus Inactivity Time Limit** specifies the maximum time that the SAS target port is permitted to maintain a connection without transferring a frame to the initiator port, specified in 100 microsecond increments. When this value is exceeded, the target port will prepare to close the connection by transmitting DONE. A value of zero indicates that there is no bus inactivity time limit.
- **Disconnect Time Limit** is not supported.
- **Write Buffer Empty Ratio** is the numerator of a fraction whose denominator is 256. The fraction indicates how empty the drive data buffer should be before attempting to re-arbitrate for the link. If the ratio is set to 0h, the target will calculate and use an optimal ratio based on the negotiated transfer rate.

Both the Read Buffer Full Ratio and the Write Buffer Empty Ratio pertain to the current active notch. For each active notch as defined in page 0Ch there are separate Read Buffer Full Ratios and Write Buffer Empty Ratios. When the active notch is set to zero, the values are applied in mode page 0Ch across all notches.

- **Maximum Connect Time Limit** specifies the maximum amount of time the drive will keep a SAS connection open. The time is specified in 100 microsecond increments. The default value of zero, indicates no time limit. A maximum value of FFFFh, specifies a connection time limit of 6.55 seconds. When this time expires, the drive will prepare to close the connection.

- **Maximum Burst Size** field indicates the maximum amount of data that the target port shall transfer during a single data transfer operation. This value is expressed in increments of 512 bytes. A value of zero specifies there is no limit on the amount of data transferred per data transfer operation.
- **First Burst Size** is not supported.



## 18.10.5 Mode Page 03 (Format Device Parameters)

Table 103: Mode Page 03 (Format Device Parameters)

Byte	Bit								Default	
	7	6	5	4	3	2	1	0		
0	PS	0	Page Code = 03h							03h
1	Page Length = 16h								16h	
2-3	(MSB) Tracks per Zone								xxh	
									(LSB) xxh	
4-5	(MSB) Alternate Sectors per Zone = 0								00h	
									(LSB) 00h	
6-7	(MSB) Alternate Tracks per Zone = 0								00h	
									(LSB) 00h	
8-9	(MSB) Alternate Tracks per Logical Unit = 0								00h	
									(LSB) 00h	
10-11	(MSB) Sectors Per Track								xxh	
									(LSB) xxh	
12-13	(MSB) Data Bytes per Physical Sector								xxh	
									(LSB) xxh	
14-15	(MSB) Interleave = 0001h or 0000h								00h	
									(LSB) 01h	
16-17	(MSB) Track Skew Factor								xxh	
									(LSB) xxh	
18-19	(MSB) Cylinder Skew Factor								xxh	
									(LSB) xxh	
20	SSEC	HSEC	RMB	SURF	RESERVED = 0				40h	
21-23	Reserved = 0								00h	

The format device page contains parameters that specify the medium format. This page contains no changeable parameters.

- **Tracks per Zone** specifies the number of tracks within the zone. This field is a function of the active notch.
- **Sectors per Track** specifies the number of physical sectors within each track. This field is a function of the active notch.
- **Data Bytes per Physical Sector** specifies the number of user data bytes per physical sector. The value depends upon the current formatted Block Length.
- **Interleave** value of 1 or 0 is valid. However, the drive will ignore this.
- **Track Skew Factor** indicates the number of physical sectors between the last block of one track and the first block on the next sequential track of the same cylinder. This field is a function of the active notch.
- **Cylinder Skew Factor** indicates the number of physical sectors between the last block of one cylinder and the first block on the next sequential cylinder. This field is a function of the active notch.
- **SSEC = Zero** indicates that the drive does not support soft sector formatting.
- **HSEC = One** indicates that the drive supports hard sector formatting.
- **RMB = Zero** indicates that the media does not support removable Fixed Disk.
- **SURF = Zero** indicates that progressive addresses are assigned to all logical blocks in a cylinder prior to allocating addresses within the next cylinder.

## 18.10.6 Mode Page 04 (Rigid Disk Drive Geometry Parameters)

Table 104: Mode Page 04 (Rigid Disk Drive Geometry Parameters)

Byte	Bit								Default	
	7	6	5	4	3	2	1	0		
0	PS	0	Page Code = 04h							04h
1	Page Length = 16h								16h	
2-4	(MSB) Number of Cylinders								xxh	
	(LSB)								xxh	
5	Number of heads								xxh	
6-8	(MSB) Starting Cylinder - Write Precompensation = 0								00h	
	(LSB)								00h	
9-11	(MSB) Starting Cylinder - Reduced Write Current = 0								00h	
	(LSB)								00h	
12-13	(MSB) Drive Step Rate = 0 (Not used)								00h	
	(LSB)								00h	
14-16	(MSB) Landing Zone Cylinder = 0 (Not used)								00h	
	(LSB)								00h	
17	RESERVED = 0					RPL = 0			00h	
18	Rotational Offset = 0 (Not used)								00h	
19	RESERVED = 0								00h	
20-21	(MSB) Medium Rotation Rate in RPM								1Ch	
	(LSB)								20h	
22-23	Reserved = 0								00h	

The rigid disk drive geometric page specifies various parameters for the drive.

- **RPL = 0**, Indicates that the drive does not support spindle synchronization.

## 18.10.7 Mode Page 07 (Verify Error Recovery Parameters)

Table 105: Mode Page 07 (Verify Error Recovery Parameters)

Byte	Bit								Default
	7	6	5	4	3	2	1	0	
0	PS	0	Page Code = 07h						87h
1	Page Length = 0Ah								0Ah
2	Reserved = 0			EER=0	PER	DTE	DCR	00h	
3	Verify Retry Count								01h
4	Obsolete =0								00h
5 - 9	Reserved = 0								00h
10-11	(MSB)	Verify Recovery Time Limit						(LSB)	00h

The Verify recovery parameters are used by the Target when recovering from and reporting errors associated with the verification of the Initiator's Data for the following commands:

- **VERIFY**
- **WRITE AND VERIFY** - the verify portion of the command only.
- **EER**. This bit is 0 since the Target does not support early recovery.
- **PER**. See below for description of bit values.
- **DTE**. (Data Terminate on Error) bit set to one specifies that data transfer will be halted when the first recovered error is encountered. PER must be set to one when DTE is set to one. DTE set to zero will cause data transfer to continue when recovered errors are encountered.
- **DCR**. See below for description of bit values.

The PER, DTE, and DCR bit settings in mode page 7 override those of mode page 1 during VERIFY and the Verify portion of WRITE AND VERIFY. The following combinations of PER and DCR are valid:

### PER DCR DESCRIPTION

- |   |   |                                                                     |
|---|---|---------------------------------------------------------------------|
| 0 | 0 | Soft errors are not reported. LDPC is applied to recover the data.  |
| 1 | 0 | Soft errors are reported. LDPC is applied to recover the data.      |
| 0 | 1 | Soft errors are not reported. LDPC is not used to recover the data. |
| 1 | 1 | Soft errors are reported. LDPC is not used to recover the data.     |
- **Verify Retry Count** sets a limit on the amount of verify recovery procedure (VRP) passes the Target attempts when recovering verify errors. The Verify Retry Count of one causes the Target to attempt up to one VRP pass per command when a medium error occurs during a verify operation. Only values of 0h and 01h are valid. The value of 0h disables all recovery.
  - **Verify Recovery Time Limit** indicates the period in 1 millisecond increments for the maximum recovery time of a single LBA during the verify operation. The value must be from 40 ms to 65535 ms (65.5 seconds). The granularity of the timer is 50 ms. If an LBA is not able to be recovered within the limit, a Check Condition will be returned.

## 18.10.8 Mode Page 08 (Caching Parameters)

Table 106: Page 08 (Caching Parameters)

Byte	Bit								Default
	7	6	5	4	3	2	1	0	
0	PS	0	Page Code = 08h						88h
1	Page Length = 12h								12h
2	IC	ABPF	CAP	DISC	SIZE	WCE	MF	RCD	04h
3	Demand Read Retention Priority				Write Retention Priority				00h
4-5	(MSB) Disable Pre-fetch Transfer Length (LSB)								FFh
6-7	(MSB) Minimum Pre-fetch (LSB)								00h
8-9	(MSB) Maximum Pre-fetch (LSB)								FFh
10-11	Maximum Pre-fetch Ceiling								FFh
12	FSW	LBCSS	DRA	Reserved = 0				00h	
13	Number of Cache Segments								08h
14-15	(MSB) Cache Segment Size (LSB)								00h
16	Reserved = 0								00h
17-19	(MSB) Non Cache Segment Size (LSB)								00h

The caching parameters page defines parameters that affect the use of the cache.

- **IC** (Initiator Control) bit of one specifies that the drive will honor the following parameters to control cache segmentation and pre-fetch: SIZE, FSW, LBCSS, Number of Cache Segments, Cache Segment Size. The drive will never pre-fetch less data than specified by ABPF, MF, Demand Read Retention Priority, Write Retention Priority, Disable Pre-fetch Transfer Length, Minimum Pre-fetch, Maximum Pre-fetch, and Maximum Pre-fetch Ceiling, but may pre-fetch more based on internal cache algorithms. When the IC bit is set to zero, all the parameters listed above are ignored, and an internal caching algorithm is used.
- **ABPF** (Abort Pre-fetch) bit of one, with DRA set to zero, causes the drive to abort the pre-fetch upon receipt of a new command. ABPF set to one takes precedence over Minimum Pre-fetch. When ABPF is zero, with DRA set to zero, the termination of any active pre-fetch is dependant upon the other parameters in this page.
- **CAP** (Caching Analysis Permitted) is not supported and is ignored. The IC bit can be used to enable or disable adaptive caching.
- **DISC** (Discontinuity) is not supported and is ignored. Pre-fetch operations will continue across cylinders, within the limits of other caching parameters on this page.
- **SIZE** (Size Enable) bit when set to one indicates that the Cache Segment Size is to be used to control caching segmentation. When SIZE is set to zero, the Initiator requests that the Number of Cache Segments is to be used to control caching segmentation.
- **WCE** (Write Cache Enable) bit when set at zero indicates that the drive must issue *Good* status for WRITE (6) or WRITE (10) command only after successfully writing the data to the media. When the WCE bit is set to one, the drive may issue *Good* status for a WRITE (6) or WRITE (10) command after successfully receiving the data but before writing it to the media. When WCE = 1, the drive operates as if AWRE = 1.

**Note:** When WCE = 1, a SYNCHRONIZE CACHE command must be done to ensure data are written to the media before powering down the Target.

- **MF** (Multiplication Factor) bit determines how the Maximum and Minimum Pre-fetch parameters are interpreted. If this bit is set to zero, the parameters are used as is. If the bit is set to one, the parameters are multiplied by the number of blocks requested in the Read Command.
- **RCD** (Read Cache Disable) bit set at zero indicates that the drive may return some or all of the data requested by a READ (6) or READ (10) command by accessing the data buffer, not the media. An RCD bit set at one indicates that the Target does not return any of the data requested by a READ (6) or READ (10) command by accessing the data buffer. All of the data requested is read from the media instead.
- **Demand Read Retention Priority** is not supported.
- **Write Retention Priority** is not supported.
- **Disable Pre-fetch Transfer Length** is used to prevent read-ahead after Read commands that are longer than the specified number of blocks. If this parameter is set to zero, a read-ahead is not performed.
- **Minimum Pre-fetch** specifies the minimum number of LBAs that the drive should
- after each READ command. A value of zero indicates that read ahead should be terminated immediately after a new command arrives, except when the new command is on the current head and track.
- **Maximum Pre-fetch** specifies the maximum number of LBAs to read ahead after a Read command.
- **Maximum Pre-fetch Ceiling** specifies the maximum number of blocks the drive should attempt to read ahead. This field is ignored.
- **FSW** (Force Sequential Write) is not supported and is ignored. All logical blocks will be written in sequential order.
- **LBCSS** (Logical Block Cache Segment Size) bit when set to one indicates that the Cache Segment Size field units shall be interpreted as logical blocks. When it is set to zero, the Cache Segment Size field units shall be interpreted as bytes.
- **DRA** (Disable Read Ahead) bit when set to one requests that the Target not read into the buffer any logical block beyond the addressed logical block(s). When it is set at zero, the Target may continue to read logical blocks into the buffer beyond the addressed logical block(s).
- **Number of Cache Segments** field is used to select the number of data buffer cache segments. This parameter is valid only when the SIZE bit is set at zero. It is ignored when SIZE is set at one.
- **Cache Segment Size** field indicates the requested segment size in Bytes or Blocks, depending upon the value of the LBCSS bit. The Cache Segment Size field is valid only when the SIZE bit is one. It is ignored when SIZE is set at zero.
- **Non Cache Segment Size** is not supported and is ignored.

## 18.10.9 Mode Page 0A (Control Mode Page Parameters)

Table 107: Page 0A (Control Mode Page Parameters)

Byte	Bit								Default
	7	6	5	4	3	2	1	0	
0	PS	0	Page Code = 0Ah						8Ah
1	Page Length = 0Ah								0Ah
2	TST=0			TMFonly=0	DPICZ	D_Sense	GLTSD=0	RLEC=0	00h
3	Queue Algorithm Modifier				Rsvd=0	QErr	DQue	00h	
4	RSVD=0	RAC=0	UA_INTLCK_CTRL=0	SWP=0	Obsolete			00h	
5	ATO	TAS=0	ATMPE	RWWP	Rsvd=0	00h			
6-7	Obsolete=0								00h
8-9	(MSB)	Busy Timeout Period						(LSB)	00h
10-11	(MSB)	Extended Self-test Routine Completion Time						(LSB)	XXh

Following are parameter options for Page 0A.

**The Descriptor Sense Data (D\_SENSE)** bit controls the format in which the drive returns sense data for CHECK\_CONDITION status:

- Setting the D\_SENSE bit to 0 specifies that the drive shall return fixed format sense data for CHECK\_CONDITION.
- Setting the D\_SENSE bit to 1 specifies that the drive shall return descriptor format sense data for CHECK\_CONDITION

- **DPICZ** (Disable Protection Information Check if protect field is Zero) bit set to zero indicates that checking of protection information bytes is enabled. A DPICZ bit set to one indicates that checking of protection information is disabled on commands with:

- a) the RDPROTECT field (see SBC-3) set to zero;
- b) the VRPROTECT field (see SBC-3) set to zero; or
- c) the ORPROTECT field (see SBC-3) set to zero.

- **Queue algorithm modifier** specifies restrictions on the algorithm used for reordering commands that are tagged with the SIMPLE message.

0h: Restricted reordering. The Target shall reorder the actual execution sequence of the queued commands from each Initiator such that data integrity is maintained for that Initiator.

1h: Unrestricted reordering allowed. The Target may reorder the actual execution sequence of the queued commands in any manner it selects. Any data integrity exposures related to command sequence order are explicitly handled by the Initiator through the selection of appropriate commands and queue tag messages.

2h-7h: RESERVED.

8: Command reordering is disabled

9-Fh: RESERVED

- **QErr** (Queue Error Management) The queue error management (QERR) field specifies how the device server shall han-

dle blocked tasks when another task receives a *Check Condition* status.

QERR value	Description
00b	Specifies that all tasks from all Initiators are blocked from execution when a Contingent Allegiance (CA condition) is pending. Those blocked tasks are allowed to resume execution in a normal fashion after the CA condition is cleared.
01b	Specifies that all tasks from all Initiators are aborted when the Target returns <i>Check Condition</i> status. A unit attention condition will be generated for each Initiator that had commands in the queue except for the Initiator that received the <i>Check Condition</i> status. The sense key will be set to <i>Unit Attention</i> and the additional sense code will be set to <i>Commands Cleared by Another Initiator</i> .
10b	Reserved
11b	Blocked tasks in the task set belonging to the Initiator to which a <i>Check Condition</i> status is sent shall be aborted when the status is sent.

- **DQue** (Disable Queuing) bit set at zero specifies that tagged queuing shall be enabled if the Target supports tagged queuing. A DQue bit set at one specifies that tagged queuing shall be disabled. Command queuing is always enabled on the drive, therefore this bit is ignored.
- **ATO** (Application Tag Owner) bit set to one specifies that the contents of the Logical Block Application Tag field in the protection information, if any, shall not be modified by the drive. An ATO bit set to zero specifies that the contents of the Logical Block Application Tag field in the protection information, if any, may be modified by the drive. If the ATO bit is set to zero, the drive will ignore the contents of the Logical Block Application Tag field in the protection information.
- **ATMPE** (Application Tag Mode Page Enabled) bit set to zero specifies that the Application Tag mode page (see SBC-3) is disabled and the contents of logical block application tags are not defined by this standard. An ATMPE bit set to one specifies that the Application Tag mode page is enabled.

If:

- a. the ATMPE is set to one;
- b. the ATO bit is set to one;
- c. the value in the DPICZ bit allows protection information checking for the specified command; and
- d. the APP\_CHK bit is set to one in the Extended Inquiry VPD page;

then:

knowledge of the value of the Application Tag shall come from the values in the Application Tag mode page as specified by the DPICZ bit.

- **RWWP** (Reject Write Without Protection) bit set to zero specifies that write commands without protection information (see SBC-3) shall be processed. A RWWP bit set to one specifies that write commands without protection information received by a device server that has been formatted with protection information shall be terminated with CHECK CONDITION status with the sense key set to ILLEGAL REQUEST and the additional sense code set to INVALID FIELD IN CDB



The ATMPE bit enables the usage of another Mode whose definition from SBC 3r26 is as follows:

**Table 108: Application Tag mode page:**

Byte	Bit							
	7	6	5	4	3	2	1	0
0	PS	SPF=1	Page Code = 0Ah					
1	Subpage Code = F0h							
2-3	Page Length = n-4							
4-15	Reserved = 0							
16-39	Application Tag descriptor [first]							
...	...							
(n-24)-n	Application Tag descriptor [last]							

**Table 109: Application Tag descriptor format**

Byte	Bit							
	7	6	5	4	3	2	1	0
0	Last	Reserved = 0						
1-5	Reserved = 0							
6-7	Logical Block Application Tag							
8-15	Logical Block Address							
16-23	Logical Block Count							

•A **LAST** bit set to one specifies that this Application Tag descriptor is the last valid Application Tag descriptor in the Application Tag mode page. A **LAST** bit set to zero specifies that the Application Tag descriptor is not the last valid Application Tag descriptor in the Application Tag mode page.

•The **LOGICAL BLOCK APPLICATION TAG** field specifies the value to be compared with the **LOGICAL BLOCK APPLICATION TAG** field associated with data read or written to the LBA.

•The **LOGICAL BLOCK ADDRESS** field contains the starting LBA for this Application Tag descriptor. The **LOGICAL BLOCK ADDRESS** field in the first Application Tag descriptor shall be set to 0000\_0000\_0000\_0000h. For subsequent Application Tag descriptors, the contents of the **LOGICAL BLOCK ADDRESS** field shall contain the sum of the values in:  
a) the **LOGICAL BLOCK ADDRESS** field in the previous Application Tag descriptor; and  
b) the **LOGICAL BLOCK COUNT** field in the previous Application Tag descriptor.

The sum of the **LOGICAL BLOCK ADDRESS** field in the Application Tag descriptor with the **LAST** bit set to one and the **LOGICAL BLOCK COUNT** field in the Application Tag descriptor with the **LAST** bit set to one shall equal the **RETURNED LOGICAL BLOCK ADDRESS** field in the **READ CAPACITY (16)** parameter data (see 5.16.2).

If an invalid combination of the **LAST** bit, **LOGICAL BLOCK APPLICATION TAG** field, and **LOGICAL BLOCK ADDRESS** field are sent by the application client, then the device server shall terminate the **MODE SELECT** command (see SPC-4) with **CHECK CONDITION** status with the sense key set to **ILLEGAL REQUEST** and the additional sense code set to **INVALID FIELD IN PARAMETER LIST**.

•The **LOGICAL BLOCK COUNT** field specifies the number of logical blocks to which this Application Tag descriptor applies.

A **LOGICAL BLOCK COUNT** field set to 0000\_0000\_0000\_0000h specifies that this Application Tag descriptor shall be ignored.

- **Busy Timeout Period** is not supported and is ignored.
- **Extended Self-test Routine Completion Time** is an advisory parameter that an Initiator may use to determine the time in seconds that the Target requires to complete self-test routine when the Target is not interrupted by an Initiator and no errors occur during execution of the self-test routine.

### 18.10.9.1 Control Extension Subpage

**Table 110: Control Extension Subpage**

Byte	Bit								Default	
	7	6	5	4	3	2	1	0		
0	PS	SPF=1	Page Code = 0Ah							4Ah
1	Subpage Code = 1								01h	
2-3	Page Length = 001Ch								001Ch	
4	Reserved = 0				TCMOS	SCSIP	IALUAE			00h
5	Reserved = 0				Initial Priority				00h	
6-31	Reserved = 0								00h	

No fields in the Control Extension subpage are currently changeable. The page is supported for compatibility only.

## 18.10.10 Mode Page 0C (Notch Parameters)

Table 111: Page 0C (Notch Parameters)

Byte	Bit								Default
	7	6	5	4	3	2	1	0	
0	PS	0	Page Code = 0Ch						8Ch
1	Page Length = 16h								16h
2	ND=1	LPN=0	Reserved = 0						80h
3	Reserved = 0								00h
4-5	(MSB) Maximum Number of Notches (LSB)								XXh
									XXh
6-7	(MSB) Active Notch (LSB)								00h
									00h
8-11	(MSB) Starting Boundary (LSB)								XXh
									XXh
12-15	(MSB) Ending Boundary (LSB)								XXh
									XXh
16-23	(MSB) Pages Notched (LSB)								0000h
									0000h
								0000h	
								100Ch	

The notch page contains parameters for direct-access devices that implement a variable number of blocks per cylinder. Each section of the logical unit with a different number of blocks per cylinder is referred as a notch. The only field that is changeable is the **Active Notch** field.

- **ND** = One meaning that this device is a notched drive.
- **LPN** = Zero meaning that the notches are based upon physical parameters of the drive (cylinder #), not logical parameters.
- **Maximum Number of Notches** is the number of notches the drive can support. This value is drive model dependent.
- **Active Notch** indicates to which notch subsequent MODE SELECT/SENSE command parameters pertain. A value of 0 is used for parameter values which apply to all notches. Values from 1 to the maximum value depending on the model specify the notch number, where notch 1 is the outermost notch. Following mode parameters are based on the current active notch:
  - **Mode Page 2**
    - Read Buffer Full Ratio
    - Write Buffer Empty Ratio
  - **Mode Page 3**
    - Alternate Sector per Zone
    - Alternate Track per Zone

- Alternate Track per Logical Unit
  - Sector per Track
  - Track Skew Factor
  - Cylinder Skew Factor
- **Starting Boundary** contains the first physical location of the active notch. The first three bytes are the cylinder number and the last byte is the head. The value sent in this field is ignored.
  - **Ending Boundary** contains the last physical location of the active notch. The first three bytes are the cylinder number and the last byte is the head. The value sent in this field is ignored.
  - **Pages Notched** is a bit map of the mode page codes that indicates which pages contain parameters that may be different for different notches. The most significant bit of this field corresponds to page code 3Fh and the least significant bit corresponds to page code 00h. If a bit is one, then the corresponding mode page contains parameters that may be different for different notches. If a bit is zero, then the corresponding mode page contains parameters that are constant for all notches.

### 18.10.11 Mode Page 18h

(SAS only)

**Table 112: Page 18h (Protocol-Specific Logical Unit mode page)**

Byte	Bit								Default	
	7	6	5	4	3	2	1	0		
0	PS=0	SPF=0	Page Code = 18h							18h
1	Page Length = 6h								6h	
2	Reserved		Transport Layer Retries=0			Protocol Identifier = 6h			6h	
3	Reserved = 0								00h	
4-7	Reserved								00h	

This page defined protocol-specific parameters that affect the logical unit.

- Transport Layer Retries is unchangeable and set to zero. The drive does not support Transport Layer Retries as defined in SAS 1.1.

## 18.10.12 Mode Page 19h (Port Control Parameters)

The Protocol-Specific Port mode page contains parameters that affect SSP target port operation. There is one copy of the mode page shared by all SSP initiator ports.

### 18.10.12.1 Short Format of Port Control Page

Table 113: Short (Port Control Parameters) Short Format

Byte	Bit								Default
	7	6	5	4	3	2	1	0	
0	PS	SPF=0	Page Code = 19h						99h
1	Page Length = 0Eh								0Eh
2	Reserved	Continue AWT = 0	Broadcast Asynchronous Event	Ready LED Meaning	Protocol Identifier = 6h				06h
3	Reserved								00h
4-5	(MSB) I_T NEXUS LOSS TIMER (LSB)								07h-D0h
6-7	(MSB) INITIATOR RESPONSE TIMEOUT (LSB)								07h-D0h
8-9	(MSB) REJECT TO OPEN LIMIT = 0000h (LSB)								0000h
10-15	Reserved								00h

- The Parameters Savable (PS) bit is set to one, indicating the parameters are saveable.
- The **SPF** field shall be set to zero for access to the short format mode page.
- **Protocol Identifier** has a value of 6h indicating this is a SAS SSP specific mode page.
- A **CONTINUE AWT** bit set to one specifies that the SAS port shall not stop the Arbitration Wait Time timer and set the Arbitration Wait Time timer to zero when the SAS port receives an OPEN\_REJECT (RETRY). A CONTINUE AWT bit set to zero specifies that the SAS port shall stop the Arbitration Wait Time timer and set the Arbitration Wait Time timer to zero when it receives an OPEN\_REJECT (RETRY).
- A **BROADCAST ASYNCHRONOUS EVENT** bit set to one specifies that the device server shall enable origination of Broadcast (Asynchronous Event). A BROADCAST ASYNCHRONOUS EVENT bit set to zero specifies that the device server shall disable origination of Broadcast (Asynchronous Event).
- **Ready LED Meaning** specifies the READY LED signal behavior. In general, when the bit is 0, and the drive is in a ready state, the LED is usually on, but flashes on and off when commands are processed. When the bit is 1, the LED is usually off, but flashes on and off when commands are processed. For additional implementation specifics, see the SAS 2 draft standard.

- The **I\_T NEXUS LOSS TIME** field contains the time (in milliseconds) that our SSP target port shall retry connection requests to an SSP initiator port that are rejected with responses indicating the SSP initiator port may no longer be present before recognizing an I\_T nexus loss. A value of 0 indicates a vendor specific amount of time and defaults to a 2 second time period. A value of FFFFh indicates an unlimited period. The default value of 7D0h, specifies a 2 second time period.
- **INITIATOR RESPONSE TIMEOUT** field contains the time in milliseconds that the SSP target port shall wait for the receipt of a Data frame after sending the XFER\_RDY frame requesting data. When the INITIATOR RESPONSE TIMEOUT expires, the associated will be aborted. An INITIATOR RESPONSE TIMEOUT field value of zero indicates that the SSP target port shall disable the timer. This value is enforced by the transport layer. The default value of 7D0h, specifies a 2 second time period.
- **The REJECT TO OPEN LIMIT** field contains the minimum time in 10  $\mu$ s increments that the target port shall wait to establish a connection request with an initiator port on an I\_T nexus after receiving an OPEN\_REJECT (RETRY), OPEN\_REJECT (CONTINUE 0), or OPEN\_REJECT (CONTINUE 1). This value may be rounded as defined in SPC-4. A REJECT TO OPEN LIMIT field set to 0000h indicates that the minimum time is vendor specific. This minimum time is enforced by the transport layer.

### 18.10.12.2 Long Format of Port Control Page

Table 114: Long Format of Port Control Page

Byte	Bit								Default
	7	6	5	4	3	2	1	0	
0	PS	SPF=1	Page Code = 19h						D9h
1	Subpage Code								...
2-3	(MSB) Page Length (n-3) (LSB)								0000h
4	RSVD								00h
5	RSVD				Protocol Identifier = 6h				06h
6	Protocol Specific Mode Parameters								...
n									...

The drive maintains an independent set of port control mode page parameters for each SAS initiator port.

- The **SPF** field shall be set to one for access to the long format mode page.
- **Subpage Code** indicates which subpage is being accessed. The drive support the following subpage codes. If the Subpage Code is not supported, the drive returns a CHECK CONDITION status, the sense key is set to ILLEGAL REQUEST and the additional sense code set to ILLEGAL FIELD IN PARAMETER LIST.
  - 01h: PHY Control and Discover Subpage
  - 02h: Shared Port Control subpage
  - FFh: All supported subpages.
- **Page Length** specifies the length in bytes of the subpage parameters after the Page Length.

- **Protocol Identifier** has a value of 6h indicating this is a SAS SSP specific mode page.

### 18.10.12.3 PHY Control and Discover (Subpage 1)

Table 115: PHY Control and Discover (Subpage 1)

Byte	Bit								Default	
	7	6	5	4	3	2	1	0		
0	PS	SPF=1	Page Code = 19h							D9h
1	Subpage Code = 1								01h	
2-3	(MSB) Page Length = 0064h (LSB)								0064h	
4	Reserved								00h	
5	Reserved				Protocol Identifier = 6h				06h	
6	Generation Code								00h	
7	Number of PHYS = 2								02h	
8-55	SAS PHY Mode Descriptor 0								...	
56-103	SAS PHY Mode Descriptor 1								...	

The Phy Control And Discover subpage contains phy-specific parameters. MODE SENSE command returns the current settings for the initiator.

- **Protocol Identifier** has a value of 6h indicating this is a SAS SSP specific mode page.
- **The GENERATION CODE field** is a one-byte counter that shall be incremented by one by the device server every time the values in this mode page or the SAS-2 Phy mode page (see 10.2.7.7) field values are changed. A GENERATION CODE field set to 00h indicates the generation code is unknown. The device server shall wrap this field to 01h as the next increment after reaching its maximum value (i.e., FFh). The GENERATION CODE field is also contained in the Protocol-Specific Port log page and may be used to correlate phy settings across mode page and log page accesses.
- **Number of PHYS** field is set to 2, to represent the dual ported drive (one PHY per port)



- The **SAS PHY Mode Descriptor** Fields are defined in Table 116 on page 161. There are two SAS PHY Mode Descriptor fields, one per port.

**Table 116: SAS PHY Mode Descriptor**

Byte	Bit							
	7	6	5	4	3	2	1	0
0	Reserved							
1	PHY IDENTIFIER							
2-3	(MSB) Reserved (LSB)							
4	Reserved	ATTCHED DEVICE TYPE			ATTCHED REASON			
5	Reason				Negotiated Logical Link Rate			
6	Reserved				ATTACHED SSP INITIATOR PORT	ATTACHED STP INITIATOR PORT	ATTACHED SMP INITIATOR PORT	Reserved
7	Reserved				ATTACHED SSP TARGET PORT	ATTACHED STP TARGET PORT	ATTACHED STP TARGET PORT	Reserved
8-15	(MSB) SAS ADDRESS (LSB)							
16-23	(MSB) ATTACHED SAS ADDRESS (LSB)							
24	ATTACHED PHY IDENTIFIER							
25-31	(MSB) Reserved (LSB)							
32	PROGRAMMED MINIMUM PHYSICAL LINK RATE				HARDWARE MINIMUM PHYSICAL LINK RATE			
33	PROGRAMMED MAXIMUM PHYSICAL LINK RATE				HARDWARE MAXIMUM PHYSICAL LINK RATE			
34-41	(MSB) Reserved (LSB)							
42-43	(MSB) Vendor specific (LSB)							
44-47	(MSB) Reserved (LSB)							

- PHY Identifier:** Unique PHY Identifier for the PHY associated with the other data in this SAS PHY Mode Descriptor Page.
- Attached Reason:** indicates the value of the REASON field in the last received IDENTIFY address frame associated with the PHY Identifier list in this SAS PHY Mode Descriptor. See Table 30 on page 54.
- Attached Device Type:** indicated the value of the DEVICE TYPE field in the last received IDENTIFY address frame associated with the PHY Identifier listed in this SAS PHY Mode Descriptor. See Table 30 on page 54.
- Attached SAS Address:** indicates the value of the attached SAS address in the last received IDENTIFY address frame associated with the PHY Identifier list in this SAS PHY Mode Descriptor. See Table 30 on page 54.

- **Attached PHY Identifier:** indicated the value of the attached PHY Identifier field in the last received IDENTIFY address frame associated with the PHY Identifier listed in this SAS PHY Mode Descriptor. See Table 30 on page 54.
- **SAS Address:** Unique Port Identifier for the Port associated with the PHY Identifier listed in this SAS PHY Mode Descriptor
- **Hardware Minimum Physical Link Rate:** Minimum link rate supported by the Port associated with the PHY Identifier listed in this SAS PHY Mode Descriptor.
- **Hardware Maximum Physical Link Rate:** Maximum link rate supported by the Port associated with the PHY Identifier listed in this SAS PHY Mode Descriptor.
- **Programmed Minimum Physical Link Rate:** Current minimum link rate used during speed negotiation by the Port associated with the PHY Identifier listed in this SAS PHY Mode Descriptor.
- **Programmed Maximum Physical Link Rate:** Current maximum link rate used during speed negotiation by the Port associated with the PHY Identifier listed in this SAS PHY Mode Descriptor.

#### 18.10.12.4 Shared Port Control (Subpage 2)

Table 117: Shared Port Control (Subpage 2)

Byte	Bit								Default
	7	6	5	4	3	2	1	0	
0	PS	SPF=1	Page Code = 19h						D9h
1	Subpage Code = 2								02h
2 - 3	Page Length = 000Ch								000Ch
4	Reserved = 0								00h
5	Reserved = 0				Protocol Identifier = 6				06h
6 - 7	Power Loss Timeout								0000h
8 - 15	Reserved = 0								00h

- **Power Loss Timeout** is the maximum time, in one millisecond increments, that the drive port will respond to connection requests with OPEN\_REJECT(RETRY) after receiving NOTIFY(POWER LOSS EXPECTED). The Power Loss Timeout will be restarted after each NOTIFY(POWER LOSS EXPECTED) that is received. A POWER LOSS TIMEOUT field set to 0000h specifies that the maximum time is vendor-specific and automatically defaults to 2 seconds.

### 18.10.12.5 SAS-2 Phy Mode Page (Subpage 3)

Table 118: Subpage 3

Byte	Bit								Default
	7	6	5	4	3	2	1	0	
0	PS	SPF=1	Page Code 19h						D9h
1	Subpage Code = 3								03h
2-3	Page Length = 002Ch								002Ch
4	Reserved = 00h								00h
5	Reserved = 0				Protocol Identifier = 6				06h
6	Generation Code								00h
7	Number of Phys = 02h								02h
8-27	SAS-2 PHY Mode Descriptor 0								--
28-47	SAS-2 PHY Mode Descriptor 1								--

- **The GENERATION CODE field** is a one-byte counter that shall be incremented by one by the device server every time the values in this mode page or the SAS-2 Phy mode page (see 10.2.7.7) field values are changed. A GENERATION CODE field set to 00h indicates the generation code is unknown. The device server shall wrap this field to 01h as the next increment after reaching its maximum value (i.e., FFh). The GENERATION CODE field is also contained in the Protocol-Specific Port log page and may be used to correlate phy settings across mode page and log page accesses.

Table 119: PHY Mode Descriptor (0 and 1)

Byte	Bit							
	7	6	5	4	3	2	1	0
0	Reserved							
1	PHY Identifier							
2-3	Descriptor Length (0010h)							
4-7	Programmed PHY Capabilities							
8-11	Current PHY Capabilities							
12-15	Attached PHY Capabilities							
16-17	Reserved							
18	Reserved			Negotiated SSC		Negotiated Physical Link Rate		
19	Reserved							Hardware Muxing Supported='0'

- **Phy Capabilities are defined under the “SAS Speed Negotiation” on page 52**

### 18.10.13 Mode Page 1A (Power Control)

Table 120: Page 1A (Power Control)

Byte	Bit								Default	
	7	6	5	4	3	2	1	0		
0	PS	SPF (0b)	Page Code = 1Ah							1Ah
1	Page Length = 26h								26h	
2	PM_BG_PRECEDENCE	Reserved = 0					Standby_Y			00h
3	Reserved = 0				Idle_C	Idle_B	Idle_A	Standby_Z	06h	
4-7	Idle_A Condition Timer								14h	
8-11	Standby_Z Condition Timer								00h	
12-15	Idle_B Condition Timer								1770h	
16-19	Idle_C Condition Timer								00h	
20-23	Standby_Y Condition Timer								00h	
24-39	Reserved = 0								00h	
24-39	FIDCPC		FSBCPC		FSTCPC		Reserved = 0		00h	

- If the **STANDBY\_Y bit** is set to one, then the standby\_y condition timer is enabled. If the STANDBY\_Y bit is set to zero, then the device shall ignore the standby\_y condition timer.
- If the **IDLE\_C bit** is set to one, then the idle\_c condition timer is enabled. If the IDLE\_C bit is set to zero, then the device shall ignore the idle\_c condition timer.
- If the **IDLE\_B bit** is set to one, then the idle\_b condition timer is enabled. If the IDLE\_B bit is set to zero, then the device shall ignore the idle\_b condition timer.
- If the **IDLE\_A bit** is set to one, then the idle\_a condition timer is enabled. If the IDLE\_A bit is set to zero, then the device shall ignore the idle\_c condition timer.
- If the **STANDBY\_Z bit** is set to one, then the standby\_z condition timer is enabled. If the STANDBY\_Z bit is set to zero, then the device shall ignore the standby\_z condition timer.
- The **IDLE\_A Condition Timer** field specifies the initial value, in 100 millisecond increments, for the idle\_a power condition timer. The minimum allowable inactivity time for idle\_a is 1 second. Any value less than this is accepted, but will automatically default to 1 second.
- The **STANDBY\_Z Condition Timer** field specifies the initial value, in 100 millisecond increments, for the standby\_z power condition timer. The minimum allowable inactivity time for standby\_z is 2 minutes. Any value less than this is accepted, but will automatically default to two minutes. In addition, a limit of 60 timer initiated head unloads per 24 hour period is enforced.
- The **IDLE\_B Condition Timer** field specifies the initial value, in 100 millisecond increments, for the idle\_b power condition timer. The minimum allowable inactivity time for idle\_b is 2 minutes. Any value less than this is accepted, but will automatically default to two minutes. In addition, a limit 60 timer initiated head unloads per 24 hour period is enforced.
- The **IDLE\_C Condition Timer** field specifies the initial value, in 100 millisecond increments, for the idle\_c power condition timer. The minimum allowable inactivity time for idle\_c is 2 minutes. Any value less than this is accepted, but will automatically default to two minutes. In addition, a limit of 60 timer initiated head unloads per 24 hour period is enforced.
- The **STANDBY\_Y Condition Timer** field specifies the initial value, in 100 millisecond increments, for the standby\_y power condition timer. The minimum allowable inactivity time for standby\_y is 2 minutes. Any value less than this is accepted, but will automatically default to two minutes. In addition, a limit 60 timer initiated head unloads per 24 hour period is enforced.
- The **PM\_BG\_PRECEDENCE** field (see Table 121: ) specifies the interactions between background functions and power

Table 121: PM\_BG\_PRECEDENCE field

Code	Vendor Specific
00h	PS
01b	<p>Performing background functions take precedence over maintaining low power conditions as follows:</p> <p>a) if the logical unit is in a low power condition as the result of a power condition timer associated with that condition expiring, then:</p> <ol style="list-style-type: none"> <li>1) the logical unit shall change from that power condition, if necessary, to the power condition required to perform the background function, when: <ol style="list-style-type: none"> <li>a) a timer associated with a background scan operation expires, and that function is enabled or</li> <li>b) an event occurs to initiate a device specific background function, and that function is enabled;</li> </ol> </li> <li>2) the logical unit shall perform the background function(s) based on the definitions in this standard and other command standards (e.g., if the device server receives a command while performing a background function, then the logical unit shall suspend the function to process the command);</li> <li>3) if more than one condition is met to initiate a background function, then: <ol style="list-style-type: none"> <li>a) all initiated background functions shall be performed; and</li> <li>b) the order of performing the functions is vendor specific; and</li> </ol> </li> <li>4) when all initiated background functions have been completed, the device server shall check to see if any power condition timers have expired. If any power condition timer has expired, then the logical unit shall change to the power condition associated with the highest priority timer that has expired;</li> </ol> <p>or</p> <p>b) if the logical unit is performing a background function, and a power condition timer expires, then the logical unit shall perform all initiated background functions before the logical unit changes to a power condition associated with a timer has expired</p>
10b	<p>Maintaining low power conditions take precedence over performing background functions as follows:</p> <p>a) if the logical unit is in a low power condition, then the logical unit shall not change from that power condition to perform a background function;</p> <p>b) the device server may perform any initiated and enabled background function based on the definitions in this standard or other command standards, if all of the following are true:</p> <ol style="list-style-type: none"> <li>A) a condition is met to initiate a background function;</li> <li>B) that background function is enabled;</li> <li>C) the logical unit changes to a power condition in which the background function may be performed (e.g., the device server processes a medium access command causing the logical unit to change its power condition to continue processing that command); and</li> <li>D) all outstanding application client requests have been completed;</li> </ol> <p>or</p> <p>c) if the logical unit is performing a background function, and a power condition timer expires that causes a change to a power condition in which the logical unit is unable to continue performing the background function, then the logical unit shall:</p> <ol style="list-style-type: none"> <li>A) suspend the background function; and</li> <li>B) change to the power condition associated with the timer that expired.</li> </ol>
11b	Reserved = 0



## 18.10.14 .Mode Page 1C (Informational Exceptions Control)

Table 122: Page 1C (Informational Exceptions Control)

Byte	BIT								Default	
	7	6	5	4	3	2	1	0		
0	PS	0	Page Code = 1Ch							9Ch
1	Page Length = 0Ah								0Ah	
2	PERF	RSVD	EBF	EWASC	DEXCPT	TEST	EBACK-ERR	LOGERR	10h	
3	Reserved = 0				Method of Reporting				03h	
4-7	(MSB) Interval Timer (LSB)								00h	
									00h	
									00h	
									00h	
8-11	(MSB) Report Count (LSB)								00h	

- **PERF** (Performance) bit is not supported and is ignored. Informational Exception operations will not cause performance delays.
- **EBF** (Enable Background Function) bit is not supported and is ignored. Background functions are always enabled.
- **EWASC** (Enable Warning ASC) bit of zero indicates that Temperature Warnings will not be reported. An EWASC bit of one allows Temperature Warnings to be reported, if the temperature inside the disk enclosure exceeds the threshold set in Mode Page 00h. The Method of Reporting field controls the reporting method. EWASC is independent of DEXCPT.
- **DEXCPT** (Disable Exception Control) bit of zero indicates information exception operations are enabled. The reporting of information exception conditions when the DEXCPT bit is set to zero is determined from the Method of Reporting field. A DEXCPT bit of one indicates the Target disabled all information exception operations.
- **TEST** bit of one instructs the drive to generate false drive notifications at the next interval time, (as determined by the INTERVAL TIMER field), if the DEXCPT is zero. The Method of Reporting and Report Count would apply. The false drive failure is reported as sense qualifier 5DFFh. The TEST bit of zero instructs the drive to stop generating any false drive notifications.
- **Enable Background Error (EBACKERR)** bit of zero disables reporting of background self-test errors and background scan errors via Information Exceptions Control. An EBACKERR bit of one enables reporting of these background errors as Information Exception Warnings. The method of reporting these errors is determined from the MRIE field.
- **LOGERR** (Log Errors) is not used and ignored internally by the Target.

- **Method of Reporting Informational Exceptions** indicates the methods used by the Target to report informational exception conditions.

**Code Description**

- 0h No reporting of informational exception condition:** This method instructs the Target to not report informational exception condition.
- 1h Asynchronous event reporting:** Not supported.
- 2h Generate unit attention:** This method instructs the Target to report informational exception conditions by returning a *Check Condition* status on any command. The sense key is set to *Unit Attention* and the additional sense code indicates the cause of the informational exception condition. The command that has the *Check Condition* is not executed before the informational exception condition is reported.
- 3h Conditionally generate recovered error:** This method instructs the Target to report informational exception conditions, dependent on the value of the PER bit of the error recovery parameters mode page, by returning a *Check Condition* status on any command. The sense key is set to *Recovered Error* and the additional sense code indicates the cause of the informational exception condition. The command that has the *Check Condition* completes without error before any informational exception condition is reported.
- 4h Unconditionally generate recovered error:** This method instructs the Target to report informational exception conditions, regardless of the value of the PER bit of the error recovery parameters mode page, by returning a *Check Condition* status on any command. The sense key is set to *Recovered Error* and the additional sense code indicates the cause of the informational exception condition. The command that has the *Check Condition* completes without error before any informational exception condition is reported.
- 5h Generate no sense:** This method instructs the Target to report informational exception conditions by returning a *Check Condition* status on any command. The sense key is set to *No Sense* and the additional sense code indicates the cause of the informational exception condition. The command that has the *Check Condition* completes without error before any informational exception condition is reported.
- 6h Only report informational exception condition on request:** This method instructs the Target to preserve the informational exception(s) information. To find out about information exception conditions the Application Client polls the Target by issuing an unsolicited *Request Sense* command. The sense key is set to *No Sense* and the additional sense code indicates the cause of the informational exception condition.
- 7h-Fh Reserved.**

- **Interval Timer** field indicates the period in 100 millisecond increments for reporting that an informational exception condition has occurred. The target shall not report informational exception conditions more frequently than the time specified by the Interval Timer field and as soon as possible after the time interval has elapsed. After the informational exception condition has been reported the interval timer is restarted. A value of zero or 0xFFFFFFFF in the Interval Timer field indicates that the target only reports the informational exception condition one time and will override the value set in the Report Count field.
- **Report Count** field indicates the number of times the Target reports an informational exception condition. The Report Count of ZERO indicates no limits on the number of times the Target reports an informational exception condition.



### 18.10.14.1 Background Control (Subpage 01h)

Table 123: Background Control (Subpage 01h)

Byte	BIT								Default	
	7	6	5	4	3	2	1	0		
0	PS	SPF=1	Page Code = 1Ch							DCh
1	Subpage Code = 01h								01h	
2-3	Page Length = 0Ch								000Ch	
4	Reserved = 0					S_L_Full	LOWIR	EN_BMS	01h	
5	Reserved = 0							EN_PS	00h	
6-7	Background Medium Scan Interval Time								00A8h	
8-9	Background Pre-Scan Time Limit								0000h	
10-11	Minimum Idle Time Before Background Scan								0000h	
12-13	Maximum Time To Suspend Background Scan (Ignored)								0000h	
14-15	Reserved = 0								0000h	

- **Suspend On Log Full (S\_L\_FULL)** bit set to zero allows background scans to continue if the results log (Log Sense Page 15h) is full. S\_L\_FULL bit set to one will cause background scans to suspend when the log is full.
- **Log Only When Intervention Required (LOWIR)** bit set to zero allows logging of all medium errors in the results log (Log Sense Page 15h). When the LOWIR bit is set to one, only unrecovered medium errors will be logged.
- **EN\_BMS (Enable Background Medium Scan)** bit set to zero specifies that the background medium scan is disabled. EN\_BMS bit set to one specifies that background medium scan operations are enabled. If a background medium scan is in progress when the EN\_BMS bit is changed from one to zero, then the medium scan shall be suspended until the EN\_BMS bit is set to one, at which time the medium scan shall resume from the suspended location.
- **EN\_PS (Enable Pre-Scan)** bit set to zero specifies that the pre-scan is disabled. If a pre-scan operation is in progress when EN\_PS is changed from a one to a zero, then pre-scan is halted. An EN\_PS bit set to one specifies that a pre-scan operation is started after the next power-on cycle. Once this pre-scan has completed, another pre-scan shall not occur unless the EN\_PS bit is set to zero, then set to one, and another power-on cycle occurs.
- **Background Medium Scan Interval Time** specifies the minimum time, in hours, between the start of one background medium scan operation and the start of the next background medium scan operation.
- **Background Pre-Scan Time Limit** specifies the maximum time, in hours, for a pre-scan operation to complete. If the pre-scan operation does not complete within the specified time, then it is halted. A value of zero specifies an unlimited time limit.
- **Minimum Idle Time Before Background Scan** specifies the minimum time, in milliseconds, that the drive must be idle before resuming a background media scan or pre-scan. A value of zero will be treated as the default value of 1.0 second. Any value less than 100 milliseconds will be treated as 100 milliseconds. The internal timer granularity is 50 milliseconds.
- **Maximum Time To Suspend Background Scan (Ignored).**

## 18.11 MODE SENSE (5A)

Table 124: Mode Sense (5A)

Byte	Bit							
	7	6	5	4	3	2	1	0
0	Command Code = 5Ah							
1	Reserved = 0			LLBAA	DBD	Reserved = 0		
2	PCF		Page Code					
3	Subpage code							
4-6	Reserved = 0							
7-8	(MSB)		Allocation Length				(LSB)	
9	VU = 0		Reserved = 0			FLAG	LINK	

The MODE SENSE (5A) command provides a means for the drive to report various device parameters to the initiator. See the MODE SENSE (1A) command for a description of the fields in this command.

- **Long LBA Accepted (LLBAA)** bit set to zero ensures that if a Block Descriptor is present it must be a Short LBA Block Descriptor. If the LLBAA bit is set to one, the Long LBA Block Descriptor may be used.

## 18.12 PERSISTENT RESERVE IN (5E)

Table 125: Persistent Reserve In (5E)

Byte	Bit							
	7	6	5	4	3	2	1	0
0	Command Code = 5Eh							
1	Reserved = 0			Service Action				
2-6	Reserved = 0							
7-8	(MSB) Allocation Length							(LSB)
9	VU = 0		Reserved = 0			FLAG	LINK	

The PERSISTENT RESERVE IN command is used to obtain information about persistent reservations and reservation keys that are active within the controller. This command is used in conjunction with the PERSISTENT RESERVE OUT command PERSISTENT RESERVE OUT (5F).

The **Allocation Length** indicates how much space has been allocated for the returned parameter data. If the length is not sufficient to contain all parameter data, the first portion of the data will be returned. If the remainder of the data is required, the initiator should send a new PERSISTENT RESERVE IN command and an Allocation Length large enough to contain all data.

### 18.12.1 Service Action

The following service action codes are implemented. If a reserved service action code is specified, the drive returns a **Check Condition** status. The sense key is set to *Illegal Request* and the additional sense data is set to *Invalid Field in CDB*.

Table 126: PERSISTENT RESERVE IN, Service Action Codes

Code	Name	Descriptions
00h	Read Keys	Reads all registered Reservation Keys
01h	Read Reservations	Reads all current persistent reservations
02h	Report Capabilities	Returns capability information
03h	Read Full Status	Reads complete information about all registrations and the persistent reservation, if any
04h-1Fh	Reserved	Reserved

## 18.12.2 Parameter data for Read Keys

Table 127: PERSISTENT RESERVE IN, parameter data for Read Keys

Byte	Bit							
	7	6	5	4	3	2	1	0
0-3	(MSB) <b>Generation</b> (LSB)							
4-7	(MSB) <b>Additional length (n-7)</b> (LSB)							
8-15	(MSB) <b>First reservation key</b> (LSB)							
	:							
(n-7) - n	(MSB) <b>Last reservation key</b> (LSB)							

**Generation** is a counter that increments when PERSISTENT RESERVE OUT command with “Register” or “Preempt and Clear” completes successfully. Generation is set to 0 as part of the power on reset process and hard reset process.

The **Generation** field contains a 32-bit counter that the Target shall increment every time a PERSISTENT RESERVE OUT command requests a Register, a Clear, a Preempt, or a Preempt and Abort service action. The counter shall not be incremented by a PERSISTENT RESERVE IN command, by a PERSISTENT RESERVE OUT command that performs a Reserve or Release service action, or by a PERSISTENT RESERVE OUT command that is not performed due to an error or reservation conflict. Regardless of the APTPL value the generation value shall be set to 0 as part of the power on reset process.

The **Additional Length** field contains a count of the number of bytes in the reservation key list. If the allocation length specified by the PERSISTENT RESERVE IN command is not sufficient to contain the entire parameter list, then only the bytes from 0 to the maximum allowed allocation length shall be sent to the Initiator. The incremental remaining bytes shall be truncated, although the Additional Length field shall still contain the actual number of bytes in the reservation key list without consideration of any truncation resulting from an insufficient allocation length. This shall not be considered an error.

The **Reservation Key** list contains the 8-byte reservation keys for all Initiators that have registered through all ports with the Target.

### 18.12.3 Parameter Data for Read Reservations

Table 128: PERSISTENT RESERVE IN, parameter data for Read Reservations

Byte	Bit							
	7	6	5	4	3	2	1	0
0-3	(MSB) Generation (LSB)							
4-7	(MSB) Additional length (n-7) (LSB)							
8-n	(MSB) Reservation descriptors (LSB)							

The **Generation** field shall be as defined for the Persistent Reserve In Read Keys parameter data. The Additional Length field contains a count of the number of bytes to follow in the Reservation Descriptor(s).

If the **Allocation length** specified by the PERSISTENT RESERVE IN command is not sufficient to contain the entire parameter list, then only the bytes from 0 to the maximum allowed allocation length shall be sent to the Initiator. The remaining bytes shall be truncated, although the Additional Length field shall still contain the actual number of bytes of the Reservation Descriptor(s) and shall not be affected by the truncation. This shall not be considered an error.

The format of the **Reservation Descriptors** is defined in the Persistent Reserve In Reservation Descriptor table. There shall be a Reservation Descriptor for the persistent reservation, if any, present in the Target having a persistent reservation.

Table 129: PERSISTENT RESERVE IN, Read Reservation Descriptor

Byte	Bit							
	7	6	5	4	3	2	1	0
0-7	(MSB) Reservation key (LSB)							
8-11	(MSB) Scope-specific address (LSB)							
12	Reserved							
13	Scope=0				Type			
14-15	(MSB) Extent Length=0 (LSB)							

The **Scope** of each persistent reservation created by a PERSISTENT RESERVE OUT command will be returned. See the PERSISTENT RESERVE OUT command section for details.

## 18.13 PERSISTENT RESERVE OUT (5F)

Table 130: PERSISTENT RESERVE OUT (5F)

Byte	Bit							
	7	6	5	4	3	2	1	0
0	Command Code = 5Fh							
1	Reserved = 0			Service Action				
2	Scope=0				Type			
3-6	Reserved = 0							
7-8	Parameter List Length = 18h							
9	VU = 0		Reserved = 0				FLAG	LINK

The PERSISTENT RESERVE OUT command is used to request service actions that reserve the drive for the exclusive or shared use of the initiator. The command uses other service actions to manage and remove such reservations. This command is used in conjunction with the PERSISTENT RESERVE IN command, and should not be used with the RESERVE and RELEASE commands.

Note: If a PERSISTENT RESERVE OUT command is received when a RESERVE is active for the drive, the command will be rejected with **Reservation Conflict** status.

**Parameter List Length** must be 18h. If not, Check Condition status will be returned, with sense key of Illegal Request and additional sense code of Parameter List Length Error.

## 18.13.1 Service Action

The following service action codes are supported.

**Table 131: PERSISTENT RESERVE OUT, Service Action Code**

Code	Name	Description
00h	Register	Register a reservation key
01h	Reserve	Create a persistent reservation using a reservation key
02h	Release	Release a persistent reservation
03h	Clear	Clear all reservation keys and all persistent reservations
04h	Preempt	Preempt persistent reservations from another Initiator
05h	Preempt and Abort	Preempt persistent reservations from another Initiator and clear the task set for the preempted Initiator
06h	Register and Ignore existing key	Register a reservation key
07h-1Fh	Reserved	Reserved

## 18.13.2 Type

The **Type** field specifies the characteristics of the persistent reservation being established for all customer data sectors. The table below describes the supported types and how read and write commands are handled for each reservation type.

**Table 132: PERSISTENT RESERVE OUT, Type Code**

Code	Name	Description
0h	Reserved	Reserved
1h	Write Exclusive	Reads Shared: Any initiator may execute commands that transfer from the media. Writes Exclusive: Only the initiator with the reservation may execute commands that transfer data to the media; Reservation Conflict status will be returned to other initiators.
2h	Reserved	Reserved
3h	Exclusive Access	Reads Exclusive: Only the initiator with the reservation may execute commands that transfer data from the media; Reservation Conflict status will be returned to other initiators. Writes Exclusive: Only the initiator with the reservation may execute commands that transfer data to the media; Reservation Conflict status will be returned to other initiators.

<b>4h</b>	Reserved	Reserved
<b>5h</b>	Write Exclusive Registrants Only	Reads Shard: Any initiator may execute commands that transfer from media. Writes Exclusive: Only registered initiators may execute commands that transfer data to the media; Reservation Conflict status will be returned to other initiators.
<b>6h</b>	Exclusive Access Registrants Only	Reads Exclusive: Only registered initiators may execute commands that transfer data from the media; Reservation Conflict status will be returned to other initiators. Writes Exclusive: Only registered initiators may execute commands that transfer data to the media; Reservation Conflict status will be returned to other initiators.
<b>7h-Fh</b>	Reserved	Reserved

### 18.13.3 Parameter list

The **Parameter List** required to perform the PERSISTENT RESERVE OUT command is defined in the table below. All fields must be sent on all PERSISTENT RESERVE OUT commands, even if the field is not required for the specified service action.

**Table 133: Parameter List**

Byte	Bit							
	7	6	5	4	3	2	1	0
<b>0-7</b>	<b>(MSB) Reservation Key (LSB)</b>							
<b>8-15</b>	<b>(MSB) Service Action Reservation Key (LSB)</b>							
<b>16-19</b>	<b>(MSB) Reserved = 0 (LSB)</b>							
<b>20</b>	<b>Reserved = 0</b>			<b>SPEC_I_P</b>	<b>ALL_TG_PT</b>	<b>Reserved = 0</b>		<b>APTPL</b>
<b>21-23</b>	<b>Reserved = 0</b>							

**Reservation Key** contains an 8-byte value provided by the initiator, and identifies the initiator that issued the PERSISTENT RESERVE OUT command. The Reservation Key must match the registered reservation key for the initiator for all service actions except REGISTER and REGISTER AND IGNORE EXISTING KEY.

**Service Action Reservation Key** contents vary based on the service action. For REGISTER and REGISTER AND IGNORE EXISTING KEY, the Service Action Reservation Key must contain the new reservation key to be registered. For PREEMPT and PREEMPT AND ABORT, the field contains the reservation key of the persistent reservation that is being preempted. This field is ignored for all other service actions.



If the Specify Initiator Ports (**SPEC\_I\_PT**) bit is set to zero, the device server shall apply the registration only to the I\_T nexus that sent the PERSISTENT RESERVE OUT command. If the SPEC\_I\_PT bit is set to one for any service action except the REGISTER service action, then the command shall be terminated with CHECK CONDITION status, with the sense key set to ILLEGAL REQUEST, and the additional sense code set to INVALID FIELD IN PARAMETER LIST. If the SPEC\_I\_PT bit is set to one for the REGISTER service action, the additional parameter data (see table XXX) shall include a list of transport IDs and the device server shall also apply the registration to the I\_T nexus for each initiator port specified by a TransportID. If a registration fails for any initiator port (e.g., if the logical unit does not have enough resources available to hold the registration information), no registrations shall be made, and the command shall be terminated with CHECK CONDITION status.

For Transport IDs, please refer to Table 179 on page 306 of Spc4r27.

The All Target Ports (**ALL\_TG\_PT**) bit is valid only for the REGISTER service action and the REGISTER AND IGNORE EXISTING KEY service action, and shall be ignored for all other service actions. Support for the ALL\_TG\_PT bit is optional. If the device server receives a REGISTER service action or a REGISTER AND IGNORE EXISTING KEY service action with the ALL\_TG\_PT bit set to one, it shall create the specified registration on all target ports in the SCSI target device known to the device server (i.e., as if the same registration request had been received individually through each target port). If the device server receives a REGISTER service action or a REGISTER AND IGNORE EXISTING KEY service action with the ALL\_TG\_PT bit set to zero, it shall apply the registration only to the target port through which the PERSISTENT RESERVE OUT command was received. **APTPL (Activate Persist Through Power Loss)** bit is valid only for REGISTER and REGISTER AND IGNORE EXISTING KEY, and is ignored for all other service actions. If the last valid APTPL bit value received is zero, power loss will cause all persistent reservations to be released, and all reservation keys to be removed. If the last valid APTPL bit value received is one, any persistent reservation and all reservation keys for all initiators will be retained across power cycles.

### 18.13.4 Summary

**Table 134: PERSISTENT RESERVE OUT, Service Action, Parameters**

Service Action	Parameters						Generation counter
	Scope Type	Rsv Key	SvcAct RsvKey	S-spec addr	Extent length	APTPL	
<b>(0) Register</b>	ignore	verify	save	ignore	ignore	apply	+ 1
<b>(1) Reserve</b>	apply	verify	ignore	ignore	ignore	ignore	---
<b>(2) Release</b>	apply	verify	ignore	ignore	ignore	ignore	---
<b>(5) Preempt and Abort</b>	apply	verify	save	ignore	ignore	ignore	+ 1

### 18.13.4.1 Scope, Type

The Scope and the Type are applied in the process for the Reserve, Release, and Preempted and Clear service action but they are ignored in the process for the Register service action because they are not used.

### 18.13.4.2 Reservation Key

The Reservation Key is verified in each service action process. If the Initiator that registered a key is different from the Initiator requesting PERSISTENT RESERVE OUT command, the drive returns a **Reservation Conflict** status.

### 18.13.4.3 Service Action Reservation Key

On Register service action, the drive saves the key specified in the Service Action Reservation Key field as a key of Initiator requesting PERSISTENT RESERVE OUT command.

On Preempt and Clear service action, the reservation that has a key specified in the Service Action Reservation Key field is preempted.

On other service actions, this field is ignored.

### 18.13.4.4 APTPL

The APTPL (Active Persist Through Power Loss) is valid only for the Register service action. The drive ignores the APTPL in other service actions.

The following table shows the relationship between the last valid APTPL value and information held by the drive.

**Table 135: APTPL and information held by a drive**

Information held by the drive	The last valid APTPL value	
	0	1
Registration	all keys are set to 0	retained
Persistent Reservation	all are removed	retained
Generation counter	set to 0	set to 0

### 18.13.4.5 Generation counter

The drive increments the Generation counter when Register service action or Preempt and Clear service action complete successfully.

## 18.14 PRE-FETCH (34)

Table 136: PRE-FETCH (34)

Byte	Bit							
	7	6	5	4	3	2	1	0
0	Command Code = 34h							
1	Reserved = 0			Reserved = 0			Immed = 0	Obsolete
2-5	(MSB)	Logical Block Address						(LSB)
6	Reserved = 0							
7-8	(MSB)	Transfer Length						(LSB)
9	VU = 0	Reserved = 0				FLAG	LINK	

The PRE-FETCH command requests the drive to transfer data to the cache. No data is transferred to the Initiator.

- **Transfer length** field specifies the number of contiguous blocks of data that are to be transferred into the cache. A transfer length of zero indicates that blocks are to be transferred into the cache until the segment is filled or until the last block on the media.
- **Immed** (Immediate) must be zero. An immediate bit of zero indicates that the status shall not be returned until the operation has completed.

If the Immed bit is set to one, the drive returns a **Check Condition** status. The sense key shall be set to *Illegal Request* and the additional sense code shall be set to *Invalid Field in CDB*.

## 18.15 PRE-FETCH (90)

Table 137: PRE-FETCH (34)

Byte	Bit							
	7	6	5	4	3	2	1	0
0	Command Code = 90h							
1	Reserved = 0			Reserved = 0			Immed = 0	Reserved = 0
2-9	(MSB)	Logical Block Address						(LSB)
10-13	Transfer Length							
14	Restricted For MMC-4	Reserved = 0		GROUP NUMBER = 0				
15	VU = 0		Reserved = 0			FLAG	LINK	

The PRE-FETCH command requests the drive to transfer data to the cache. No data is transferred to the Initiator.

- **Transfer length** field specifies the number of contiguous blocks of data that are to be transferred into the cache. A transfer length of zero indicates that blocks are to be transferred into the cache until the segment is filled or until the last block on the media.
- **Immed** (Immediate) must be zero. An immediate bit of zero indicates that the status shall not be returned until the operation has completed.

If the Immed bit is set to one, the drive returns a **Check Condition** status. The sense key shall be set to *Illegal Request* and the additional sense code shall be set to *Invalid Field in CDB6* - (08)

## 18.16 READ (6) - (08)

Table 138: READ (6) - (08)

Byte	Bit							
	7	6	5	4	3	2	1	0
0	Command Code = 08h							
1	Reserved = 0			(MSB) LBA				
2-3	Logical Block Address							(LSB)
4	Transfer Length							
5	VU = 0		Reserved = 0				FLAG	LINK

The READ command requests the drive to transfer from the medium to the initiator the specified number of blocks (Transfer Length) starting at the specified Logical Block Address (LBA).

- **Logical block address** field specifies the logical unit at which the READ operation shall begin.
- **Transfer length** field specifies the number of blocks to be transferred. A value of zero implies 256 blocks are to be transferred.

**Note:** Error recovery procedure (ERP) handles errors. The error recovery parameters specified by the MODE SELECT command control ERPs. If the drive is formatted with protection information, no protection information will be transmitted or checked.

## 18.17 READ (10) - (28)

Table 139: READ (10) - (28)

Byte	Bit							
	7	6	5	4	3	2	1	0
0	Command Code = 28h							
1	RDPROTECT		DPO	FUA	Rsvd=0	FUA_NV	Obsolete	
2-5	(MSB) Logical Block Address							(LSB)
6	Reserved = 0							
7-8	(MSB) Transfer Length							(LSB)
9	VU = 0	Reserved = 0				FLAG	LINK	

The READ (10) command requests the drive to transfer data to the Initiator. The larger LBA and Transfer Length fields permit greater quantities of data to be requested per command than with the READ command and are required to access the full LBA range of the larger capacity drives.

- **FUA\_NV** (Force Unit Access Non-Volatile Cache) may be set to 0 or 1, but is ignored since NV\_SUP=0 in Inquiry Page 86h.
- **Transfer length** The number of contiguous blocks to be transferred. If the transfer length is zero, the seek occurs, but no data is transferred. This condition is not considered an error. If read ahead is enabled, a read ahead is started after the seek completes.
- **DPO** (Disable Page Out) bit of one indicates that the data accessed by this command is to be assigned the lowest priority for being written into or retained by the cache. A DPO bit of one overrides any retention priority specified in the Mode Select Page 8 Caching Parameters. A DPO bit of zero indicates the priority is determined by the retention priority. The Initiator should set the DPO bit when the blocks read by this command are not likely to be read again in the near future.
- **FUA** (Force Unit Access) bit of one indicates that the data is read from the media and not from the cache. A FUA bit of zero allows the data to be read from either the media or the cache.
- **RDPROTECT** defines the manner in which protection information read from disk shall be checked during processing of the command. Protection information is stored on disk, and may be transmitted to the drive's internal data buffer and to the initiator with the user data. If the drive is not formatted with protection information, RDPROTECT must be set to 000b, else **Check Condition** status will be returned with sense key of Illegal Request and additional sense code of Invalid Field in CDB.
- RDPROTECT=000b

Protection information is not transmitted to the initiator and is not checked.

RDPROTECT=001b

- Protection information is transmitted to the initiator with the user data
- Logical Block Guard is checked
- Logical Block Application Tag is checked (applies to READ(32) command only)
- Logical Block Reference Tag is checked

RDPROTECT=010b

- Protection information is transmitted to the initiator with the user data
- Logical Block Guard is not checked
- Logical Block Application Tag is checked (applies to READ(32) command only)
- Logical Block Reference Tag is checked

RDPROTECT=011b

- Protection information is transmitted to the initiator with the user data
- Logical Block Guard is not checked
- Logical Block Application Tag is not checked
- Logical Block Reference Tag is not checked

RDPROTECT=100b

- Protection information is transmitted to the initiator with the user data
- Logical Block Guard is checked
- Logical Block Application Tag is not checked
- Logical Block Reference Tag is not checked

RDPROTECT=101b, 110b, 111b

These values are reserved. **Check Condition** status will be returned with sense key of Illegal Request and additional sense code of Invalid Field in CDB.

If a check of the protection information fails, **Check Condition** status will be returned with sense key of Aborted Command and additional sense code indicating which protection field check failed.

Refer to the ANSI T10 standards for additional details of protection information.

If the transfer length is zero, no data is transferred. The CDB is validated and protocol checked and, if no problems are found, **Good** status is returned immediately. This condition is not considered an error.

## 18.18 READ (12) - (A8)

Table 140: Read (12) - (A8)

Byte	Bit							
	7	6	5	4	3	2	1	0
0	Command Code = A8h							
1	RDPROTECT		DPO	FUA	Rsvd = 0	FUA_NV	Rsvd = 0	
2 - 5	(MSB) Logical Block Address							(LSB)
6-9	(MSB) Transfer Length							(LSB)
10	Reserved = 0							
11	VU = 0		Reserved = 0			FLAG	LINK	

The READ(12) command causes the drive to transfer data to the initiator. See the READ(10) description for the definitions of the fields in this command.



## 18.19 READ (16) - (88)

Table 141: READ (16) - (88)

Byte	Bit							
	7	6	5	4	3	2	1	0
0	Command Code = 88h							
1	RDPROTECT			DPO	FUA	Rsvd=0	FUA_NV	Rsvd=0
2 - 9	(MSB)	Logical Block Address						(LSB)
10-13	(MSB)	Transfer Length						(LSB)
14	Restricted For MMC-4	Reserved = 0		GROUP NUMBER = 0				
15	VU = 0		Reserved = 0			FLAG	LINK	

The READ(16) command causes the drive to transfer data to the initiator. See the READ(10) description for the definitions of the fields in this command.

## 18.20 READ (32) - (7F/09)

Table 142: READ (32) - (7F/09)

Byte	Bit							
	7	6	5	4	3	2	1	0
0	Command Code = 7Fh							
1	VU = 0		Reserved = 0				FLAG	LINK
2-5	Reserved = 0							
6	Reserved = 0			Group Number = 0				
7	Additional CDB Length = 18h							
8 - 9	Service Action = 0009h							
10	RDPROTECT			DPO	FUA	Rsvd=0	FUA_NV	Rsvd=0
11	Reserved = 0							
12 -19	(MSB) Logical Block Address (LSB)							
20 - 23	(MSB) Expected Initial Logical Block Reference Tag (LSB)							
24 - 25	(MSB) Logical Block Application Tag (LSB)							
26-27	(MSB) Logical Block Application Tag Mask (LSB)							
28 - 31	(MSB) Transfer Length (LSB)							

The READ command requests that the drive transfer data from disk to the initiator. Each logical block transferred includes user data and may include protection information, based on the RDPROTECT field and the drive format.

If the drive is formatted with type 2 protection (PROT\_EN=1 and P\_TYPE=001b in the READ CAPACITY (16) parameter data), then this command will be processed normally. Any other protection types will result in Check Condition status to be returned with sense key of Illegal Request and additional sense code of Invalid Command Operation Code

The Expected Initial Logical Block Reference Tag field contains the value of the Logical Block Reference Tag field expected in the protection information of the first logical block accessed by the command.

If the ATO bit is set to one in Mode Page 0Ah, the Logical Block Application Tag Mask field contains a value that is a bit mask for enabling the checking of the Logical Block Application Tag field in the protection information for each logical block accessed by the command. A Logical Block Application Tag Mask bit set to one enables the checking of the corresponding bit of the Expected Logical Block Application Tag field with the corresponding bit of the Logical Block Application Tag field in the protection information.

If the ATO bit is set to zero, the Logical Block Application Tag Mask field and the Expected Logical Block Application Tag field are ignored

## 18.21 READ BUFFER (3C)

Table 143: READ BUFFER (3C)

Byte	Bit							
	7	6	5	4	3	2	1	0
0	Command Code = 3Ch							
1	Reserved = 0			Mode				
2	Buffer ID = 0							
3-5	(MSB) Buffer Offset							(LSB)
6-8	(MSB) Allocation Length							(LSB)
9	VU = 0		Reserved = 0			FLAG	LINK	

The READ BUFFER command is used in conjunction with the WRITE BUFFER command as a diagnostic function for testing the memory of the drive and the SCSI bus integrity. This command does not alter the medium.

The function of this command and the meaning of fields within the command descriptor block depend on the contents of the mode field.

MODE	Description
00000	Read Combined Header and Data
00010	Read Data
00011	Descriptor
01010	Read Data from Echo Buffer
01011	Echo Buffer Descriptor
11010	Enable Expander Communications Protocol and Echo Buffer
All others	Not supported

### 18.21.1 Combined Header And Data (Mode 00000b)

In this mode a 4-byte header followed by data bytes is returned to the Initiator during the DATA IN phase. The Buffer ID and the buffer offset field are reserved.

The drive terminates the DATA IN phase when allocation length bytes of header plus data have been transferred or when the header and all available data have been transferred to the Initiator, whichever is less.

The 4-byte READ BUFFER header (see figure below) is followed by data bytes from the data buffer of the drive.

**Table 144: Read Buffer Header**

Byte	Bit						
	7	6	5	4	3	2	1
0	RSVD = 0						
1-3	(MSB) Buffer Capacity (LSB)						

The buffer capacity specifies the total number of data bytes that are available in the data buffer of the drive. This number is not reduced to reflect the allocation length nor is it reduced to reflect the actual number of bytes written using the WRITE BUFFER command.

Following the READ BUFFER header the drive will transfer data from its data buffer.

### 18.21.2 Read Data (Mode 00010b)

In this mode, the DATA IN phase contains buffer data.

- **Buffer ID** field must be set to zero, indicating the data transfer buffer. If another value is specified, the command is terminated with **Check Condition** status. The drive shall set sense key to *Illegal Request* and additional sense code to *Illegal Field in CDB*.
- **Buffer Offset** specifies the offset of the memory space specified by the Buffer ID. The Initiator should conform to the offset boundary requirements returned in the READ BUFFER descriptor. If the value exceeds the buffer specified, the command is terminated with **Check Condition** status. The drive shall set sense key to *Illegal Request* and additional sense code to *Illegal Field in CDB*.
- **Allocation Length** The drive terminates the DATA IN phase when allocation length bytes of data have been transferred or when the header and all available data have been transferred to the Initiator, whichever is less.

### 18.21.3 Descriptor (Mode 00011b)

In this mode, a maximum of four bytes of READ BUFFER descriptor information are returned. The drive returns the descriptor information for the buffer specified by the Buffer ID.

- **Buffer ID** field should normally be set to zero, indicating the drive data transfer buffer. If any other value is specified, the drive returns all zeros in the READ BUFFER descriptor.
- **Buffer Offset** field is reserved.
- **Allocation Length** should be set to four or greater. The drive transfers the allocation length or four bytes of READ BUFFER descriptor, whichever is less. The allocation length of zero indicates no data is transferred. The allocation length of greater than zero and less than four (size of the Descriptor) is an invalid request and will cause the command to be terminated with **Check Condition** status. The drive shall set sense key to *Illegal Request* and additional sense code to *Illegal Field in CDB*.

The READ BUFFER descriptor is defined in the figure below.

**Table 145: Read Buffer Description**

Byte	Bit						
	7	6	5	4	3	2	1
0	Offset Boundary = 0x09						
1-3	(MSB) Buffer Capacity (LSB)						

The value contained in the Buffer Offset field of subsequent WRITE BUFFER and READ BUFFER commands should be a multiple of two to the power of the offset boundary. The offset boundary is always set to nine, which indicates Sector Boundaries.

## 18.21.4 Read Data from Echo Buffer (Mode 01010b)

In this mode the drive transfers data from the echo buffer. The echo buffer will transfer the same data as when the WRITE BUFFER command was issued with the mode field set to echo buffer.

WRITE BUFFER command with the mode field set to echo buffer should be sent prior to the READ BUFFER command; otherwise the READ BUFFER command will be terminated with **Check Condition** status and *Illegal Request*.

In this mode Read Buffer transfers the specified amount of data or the amount previously written with a Write Buffer using mode 1010b from the echo buffer, whichever is less.

Issuing a Read Buffer mode 1010b before a Write Buffer mode 1010b will cause indeterminate data to be returned.

The most significant two bytes of the Allocation Length are ignored. The specified amount of data transferred should not be larger than the echo buffer capacity. The echo buffer capacity may be determined by using Read Buffer mode 1011b. Any additional data transferred over and above the echo buffer capacity is regarded as indeterminate.

The Buffer ID and Buffer Offset fields are ignored in this mode.

**Note:** The echo buffer is a separate buffer from the data buffer used with other read buffer modes. It is intended to be used for domain validation purposes.

## 18.21.5 Echo Buffer Descriptor (Mode 01011b)

In this mode, a maximum of four bytes of Read Buffer Descriptor information is returned. The drive returns the descriptor information for the echo buffer. The Buffer Offset field is reserved in this mode and must be zero. The drive transfers the lesser of the allocation length or four bytes of following Echo Buffer Descriptor.

**Table 146: Echo Buffer Descriptor**

Byte	Bit							
	7	6	5	4	3	2	1	0
0	Reserved = 0							EBOS=0
1	Reserved = 0							
2	Reserved = 0				(MSB) Buffer Capacity			
3	Buffer Capacity (LSB)							

- **EBOS** (Echo Buffer Overwritten Supported) bit of zero indicates that the echo buffer is shared by all Initiators.
- **Buffer Capacity** field returns the size of the echo buffer in byte aligned to a 4-byte boundary.

## 18.21.6 Expander Communications and Echo Buffer (Mode 11010b)

Receipt of a READ BUFFER command with this mode (11010b) causes a communicative expander to enter the expanded communication protocol mode. SCSI target devices that receive a READ BUFFER command with this mode shall process it as if it were a READ BUFFER command with mode 01010b (see 17.17.4 Read Data from Echo Buffer).

## 18.22 READ CAPACITY (10) - (25)

Table 147: READ CAPACITY (10) - (25)

Byte	Bit							
	7	6	5	4	3	2	1	0
0	Command Code = 25h							
1	Reserved = 0			Reserved = 0				Obso- lete
2-5	(MSB) Logical Block Address							(LSB)
6-7	Reserved = 0							
8	Reserved = 0							PMI
9	VU = 0	Reserved = 0				FLAG	LINK	

The READ CAPACITY command returns information regarding the capacity of the drive.

- **Logical Block Address** is used in conjunction with the PMI bit.
- **PMI** (Partial Medium Indicator) indicates:

**PMI Description**

- 0** The drive returns the last LBA of the drive.
- 1** The drive returns the last LBA and block length in bytes are that of the LBA after which a substantial delay in data transfer will be encountered. This returned LBA shall be greater than or equal to the LBA specified by the LBA fields in the CDB.

This option provides the information that the Initiator needs to determine the amount of space available on the same track that is accessible without a head switch or seek.



### 18.22.0.1 Returned Data Format

The data returned to the Initiator in response to the READ CAPACITY command is described here. The data is returned in the DATA IN phase.

**Table 148: Format of READ CAPACITY command reply**

Byte	Bit							
	6	7	5	4	3	2	1	0
0-3	(MSB) Maximum Logical Block Address (LSB)							
4-7	(MSB) Block Length (LSB)							

- **Block Length** specifies the length in bytes of each block of user data (not including protection information).

## 18.23 READ CAPACITY (16) (9E/10)

Table 149: Read Capacity (16) (9E/10)

Byte	Bit							
	6	7	5	4	3	2	1	0
0	Command Code = 9Eh							
1	Reserved = 0				Service Action = 10h			
2-9	(MSB) Logical Block Address							(LSB)
10-13	(MSB) Allocation Length							(LSB)
14	Reserved = 0							PMI
15	VU = 0	Reserved = 0					FLAG	Link

The READ CAPACITY (16) (9E/10) command returns information regarding the capacity of the drive. This command is processed like the standard READ CAPACITY (25) command.

### 18.23.1 Returned Data Format

The following data is returned to the initiator in the DATA OUT phase.

Table 150: Returned Data Format

Byte	Bit							
	6	7	5	4	3	2	1	0
0 - 7	(MSB) Maximum Logical Address							(LSB)
8 - 11	(MSB) Block Length							(LSB)
12	Reserved = 0				P-Type			Prot-EN
13 - 31	Reserved = 0							

The protection type (P\_TYPE) field and the protection enable (PROT\_EN) bit indicate the drive's current type of protection.

Prot-EN	P-Type	Description
0b	000b	The drive is formatted to type 0 protection
1b	000b	The drive is formatted to type 1 protection
1b	001b	The drive is formatted to type 2 protection

## 18.24 READ DEFECT DATA (37)

Table 151: READ DEFECT DATA (37)

Byte	Bit							
	7	6	5	4	3	2	1	0
0	Command Code = 37h							
1	Reserved = 0			Reserved = 0				0
2	Reserved = 0			Plist	Glist	Defect List Format		
3-6	Reserved = 0							
7-8	(MSB) Allocation Length							(LSB)
9	VU = 0		Reserved = 0			FLAG	LINK	

The READ DEFECT DATA command requests that the Target transfer the medium defect data to the Initiator.

If the Target is unable to access any medium defect data it will return a **Check Condition** status with the appropriate sense key. The sense key will be set to either *Medium Error* (03h) if a medium error occurred or *No Sense* (00h) if the list does not exist and the additional sense code will be set to *Defect List Error* (19h).

- **Plist** bit set to one indicates that the Target returns the Plist. A Plist bit of zero indicates that the Target shall not return the Plist of defects.
- **Glist** bit set to one indicates that the Target returns the Glist. A Glist bit of zero indicates that the Target shall not return the Glist.

**Note:** With both bits set to one Plist and Glist the Target will return both the primary and grown defect lists. With both bits set to zero, the Target will return only a 4-byte Defect List Header.

- **Defect List format** field is used by the Initiator to indicate the preferred format for the defect list.

The Defect List Format of '100 (Bytes from Index Format)' and '101 (Physical Sector Format)' are supported. If the requested format is not supported by the drive, it will return the defect list in its default format '101' and then terminate the command with **Check Condition** status. The sense key will be set to *Recovered Error* (01h) and the additional sense code will be set to *Defect List Not Found* (1Ch).

The drive sends defect list (Defect Descriptors) in a 8-byte Absolute Block Address (ABA) format that follows a four byte Defect List Header.

The Target will transfer all of the Read Defect Data up to the number of bytes allocated by the Initiator.

**Table 152: Defect List Format**

<b>Preferred Defect List Format</b>	<b>Returned Defect List Format</b>
Block (000b)	Physical Sector
Bytes from Index (100b)	Bytes from Index
Physical Sector (101b)	Physical Sector
Vendor Unique (110b)	Physical Sector
Reserved (001b)	
Reserved (010b)	
Reserved (011b)	
Reserved (111b)	

**Note:** The drive will terminate the Data In phase when the Allocation Length has been transferred or when all available Defect Data has been transferred to the Initiator, whichever is less.

The Read Defect Data contains a 4-byte header followed by zero or more defect descriptors.

## 18.24.1 Defect List Header

Table 153: Defect List Header

Byte	Bit							
	7	6	5	4	3	2	1	0
	Defect List Header							
0	Reserved = 0							
1	Reserved = 0			Plist	Glist	Defect List Format		
2-3	(MSB)			Defect List length				(LSB)

## 18.24.2 Defect List Descriptor

Table 154: Defect List Descriptor

Byte	Bit							
	7	6	5	4	3	2	1	0
	Defect List Descriptor							
0-7	Defect Descriptor 0							
.								
8n - (8n+7)	Defect Descriptor n							

### 18.24.3 Bytes from Index Format (100b)

Table 155: Defect Descriptors of Bytes from Index Format

Byte	Defect Descriptors
0-2	(MSB) Cylinder Number of Defect (LSB)
3	Head Number of Defect
4-7	(MSB) Defect Bytes from Index (LSB)

Defect Bytes from Index is gotten using the following equation:

$$\text{Bytes from Index} = (\text{Physical Sector Number}) * N$$

Where: N = Bytes per sector

### 18.24.4 Physical Sector Format (101b)

Table 156: Defect Descriptors of Physical Sector Format

Byte	Defect Descriptors
0-2	(MSB) Cylinder Number of Defect (LSB)
3	Head Number of Defect
4-7	(MSB) Defective Sector Number (LSB)

The Defect List Format field specifies the format of the defect list data returned by the Target.

The Defect List Length field specifies the length in bytes of the defect descriptors that follow. The Defect List Length is equal to eight times the number of defect descriptors.

Normally the Target will set the Defect List Length field to the amount of space needed to contain the entire defect list. However, the Target is capable of building a defect list with a length such that the entire list cannot be transferred using the maximum allocation length. If the defect list grows beyond 8191 entries, the defect data cannot be transferred with an allocation length of 0FFFFh. The Target will transfer a partial defect list and return **Check Condition** status with the sense key set to *Recovered Error* and the additional sense code set to *Partial Defect List Transferred*. The defect list length will be set to 0FFF8h, indicating the maximum number of defect descriptors that can be transferred. Defects beyond this number cannot be read by the Initiator.

## 18.25 READ DEFECT DATA (B7)

Table 157: READ DEFECT DATA (B7)

Byte	Bit							
	7	6	5	4	3	2	1	0
0	Command Code = B7h							
1	Reserved = 0			Plist	Glist	Defect List Format		
2-5	Reserved = 0							
6-9	(MSB) Allocation Length							(LSB)
10	Reserved = 0							
11	VU = 0		Reserved = 0			FLAG	LINK	

(See Section 18.24 READ DEFECT DATA (37)” on page 195.)

### 18.25.1 Defect List Header

Table 158: Defect List Header

Byte	Bit							
	7	6	5	4	3	2	1	0
	Defect List Header							
0	Reserved = 0							
1	Reserved = 0			Plist	Glist	Defect List Format		
2-3	Reserved = 0							
4-7	(MSB) Defect List length							(LSB)

(See Defect List Header for Read Defect Data (37) in Section Table 18.24.1, “Defect List Header,” on page 197.)

## 18.25.2 Defect List Descriptor

Table 159: Defect List Descriptor

Byte	Bit							
	7	6	5	4	3	2	1	0
	<b>Defect List Descriptor</b>							
0-7	<b>Defect Descriptor 0</b>							
.								
8n - (8n+7)	<b>Defect Descriptor n</b>							

(See Defect List Descriptor for Read Defect Data (37) in Section 18.24.2 Defect List Descriptor” on page 197.)

## 18.25.3 Bytes from Index Format (100b)

Table 160: Defect Descriptors of Bytes from Index Format

Byte	Defect Descriptors
0-2	(MSB) Cylinder Number of Defect (LSB)
3	Head Number of Defect
4-7	(MSB) Defect Bytes from Index (LSB)

Defect Bytes from Index is derived using the following equation:

$$\text{Bytes from Index} = (\text{Physical Sector Number}) + N$$

where N = Bytes per sector.

## 18.25.4 Physical Sector Format (101b)

Table 161: Defect Descriptors of Physical Sector Format

Byte	Defect Descriptors
0-2	(MSB) Cylinder Number of Defect (LSB)
3	Head Number of Defect
4-7	(MSB) Defective Sector Number (LSB)



## 18.26 READ LONG (3E)

Table 162: READ LONG (3E)

Byte	Bit							
	7	6	5	4	3	2	1	0
0	Command Code = 3Eh							
1	Reserved = 0					Correct = 0		Obsolete
2-5	(MSB) Logical Block Address (LSB)							
6	Reserved = 0							
7-8	(MSB) Byte Transfer Length (LSB)							
9	VU = 0		Reserved = 0			FLAG		LINK

The READ LONG command requests the drive to transfer one block of data to the Initiator. The transfer data includes data and MEDC field data.

- **Correct** transferred bit of zero causes correction to be attempted, data will be returned without reporting media errors regardless of the drives ability to successfully make corrections. When this bit is set the drive will return media errors if correction is not successful.
- **Logical Block Address** field specifies the logical block at which the read operation shall occur.
- **Byte Transfer Length** field must specify exactly the number of bytes of data that are available for transfer. If a non-zero byte transfer length does not match the available data length, the Target terminates the command with **Check Condition** status, the sense key is set to *Illegal Request*, and an additional sense code set to *Invalid Field in CDB*. The valid and ILI bits are set to one and the information field is set to the difference of the requested length minus the actual length in bytes. Negative values are indicated by two's complement notation.

The transfer length is calculated as follows:

$$transfer\ length = logical\ block\ size + 18$$

The data read by this command is neither read from nor retained in the cache. Data returned by this command can not be corrupted and transferred on a subsequent WRITE LONG command to create recoverable media errors.

## 18.27 READ LONG (9E)

Table 163: READ LONG (9E)

Byte	Bit							
	7	6	5	4	3	2	1	0
0	Command Code = 9Eh							
1	Reserved = 0			Service Action (11h)				
2-9	(MSB) Logical Block Address (LSB)							
10-11	Reserved = 0							
12-13	(MSB) Byte Transfer Length (LSB)							
14	Reserved = 0					PBLOCK		CORRCT
15	VU = 0		Reserved = 0			FLAG		LINK

The READ LONG command requests the drive to transfer one block of data to the Initiator. The transfer data includes data and MEDC field data.

- **Correct** transferred bit of zero causes correction to be attempted, data will be returned without reporting media errors regardless of the drives ability to successfully make corrections. When this bit is set the drive will return media errors if correction is not successful.
- **Logical Block Address** field specifies the logical block at which the read operation shall occur.
- **Byte Transfer Length** field must specify exactly the number of bytes of data that are available for transfer. If a non-zero byte transfer length does not match the available data length, the Target terminates the command with **Check Condition** status, the sense key is set to *Illegal Request*, and an additional sense code set to *Invalid Field in CDB*. The valid and ILI bits are set to one and the information field is set to the difference of the requested length minus the actual length in bytes. Negative values are indicated by two's complement notation.

The transfer length is calculated as follows:

$$transfer\ length = logical\ block\ size + 18$$

The data read by this command is neither read from nor retained in the cache. Data returned by this command can not be corrupted and transferred on a subsequent WRITE LONG command to create recoverable media errors.

## 18.28 REASSIGN BLOCKS (07)

Table 164: REASSIGN BLOCKS (07)

Byte	Bit							
	7	6	5	4	3	2	1	0
0	Command Code = 07h							
1	Reserved = 0						LONGLBA	Reserved = 0
2-4	Reserved = 0							
5	VU = 0	Reserved = 0				FLAG	LINK	

The REASSIGN BLOCKS command requests the drive to reassign a logical block to an available spare. The REASSIGN BLOCKS command attempts to allocate spare blocks on a spare track. The LBA is transferred to the drive during the DATA OUT phase. One to four blocks may be specified for relocation per REASSIGN BLOCKS command.

Reassignment is complete upon the completion of the REASSIGN BLOCKS command. At this time, the defective logical block address has been added to the Glist.

All data is preserved during a reassign command except for the target LBA data. The Mode Page 0h DRRT (Disable Restore Reassign Target) bit determines if the reassign blocks command will attempt to recover the Target LBA data. If the Target cannot recover the data at the Target LBA then the Initiator will have to restore the data after the REASSIGN BLOCKS command completes successfully.

If the reassignment begins to move data and is interrupted or fails to complete successfully, the Target enters a degraded mode of operation. In this mode data can be read but writing to the drive is prohibited.

Upon successful completion of this command, the location of the physical sectors reassigned during the command are added to the Glist. The reassigned sectors are marked defective and cannot be accessed again until after a format operation discards the Glist.

- **LONGLBA** bit of zero indicates that LBAs in the provided defect list are 4-bytes. A LONGLBA bit of one indicates that the LBAs in the provided defect list are 8-bytes

Following is the format of the data sent by the Initiator during the DATA OUT phase.

**Table 165: Format of Reassign Blocks Parameter List data**

Byte	Bit						
	7	6	5	4	3	2	1
0-1	Reserved = 0						
2-3	(MSB)	Defect List Length					(LSB)
4-n	Defect LBA List						

- **Defect List Length** is the total number of bytes in the Defective LBA List (n - 4).
- **Defective LBA List** is a list of zero to four Logical Block Addresses to be reassigned. The number of bytes describing each LBA is determined by the LONGLBA field in the command block.

## 18.29 RECEIVE DIAGNOSTICS RESULTS (1C)

Table 166: RECEIVE DIAGNOSTIC RESULTS (1C)

Byte	Bit							
	7	6	5	4	3	2	1	0
0	Command Code = 1Ch							
1	Reserved = 0			Reserved = 0				PCV
2	Page Code							
3	(MSB) Allocation Length							
4					(LSB)			
5	VU = 0		Reserved = 0			FLAG	LINK	

The RECEIVE DIAGNOSTIC RESULTS command requests that analysis data requested by a SEND DIAGNOSTIC command be sent to the Initiator.

- **PCV** (Page Code Valid) bit of zero indicates that the most recent SEND DIAGNOSTIC command shall define the data returned by this command. PCV bit of one indicates that the contents of the Page Code field shall define the data returned by this command.
- **Allocation Length** specifies the amount of data to be returned to the Initiator. This value may be zero and this is not considered an error. The Target terminates the Data In phase when all available data has been transferred or when the number of bytes transferred equals the Parameter List Length.

### 18.29.1 Receive Diagnostic Results Page 0

This page contains a list of supported pages.

Table 167: Receive Diagnostic Results page 0

Byte	Bit							
	7	6	5	4	3	2	1	0
0	Page Code = 0							
1	Reserved = 0							
2-3	Page Length = 03h							
4	(Supported Pages) Page = 0h							
5	CJTPAT page = 3Fh							
6	Translate address page = 40h							

The supported diagnostic page returns a list of supported pages in ascending order.

## 18.29.2 Receive Diagnostic Results Page 40

Using the SEND DIAGNOSTIC command, an address in either physical or logical format is supplied to the drive. This page is then used to retrieve the address translated into the other format.

**Table 168: Receive Diagnostic Results Page 40**

Byte	Bit							
	7	6	5	4	3	2	1	0
0	Page Code = 40h							
1	Reserved = 0							
2-3	Page Length							
4	Reserved = 0					Supplied Format		
5	RA	ALTS	ALTT	Reserved=0		Translate Format		
6-13	Translated Address							

- **Page Length** is set to 02h if the address is in a Reserved Area (RA =1). Otherwise, Page Length is set to 0Ah.
- **Supplied Format** is the value supplied by the SEND DIAGNOSTIC command; it may be 1 of the 3 following values:
  - **000b** Short Block format
  - **011b** Long Block format
  - **100b** Bytes From Index format
  - **101b** Physical Sector format
- **Translate Format** is the value supplied by the SEND DIAGNOSTIC command and specifies the format in which the address has been translated into List. If the Supplied Format is the Short Block or Long Block format, the Translate Format must be either Bytes from Index or Physical Sector format. If the Supplied Format is the Bytes from Index or Physical Sector format, the Translate Format must be Long Block format. Otherwise the Target will terminate the command with **Check Condition** status.
- **RA (Reserved Area)** is set to one if the translated block is an inaccessible sector, which could reflect a defect, an unused sector on a spare cylinder, or a sector beyond the Maximum Customer LBA.
- **ALTS (Alternate Sector)** is set to one if the translated block is a sector in a spare cylinder that points to a reassigned customer sector.
- **ALTT (Alternate Track)** is not used.
- **Translated Address** contains the address in the Translate Format. For a physical format it is as follows:

**Table 169: Translated address**

Byte	Bit							
	7	6	5	4	3	2	1	0
6-8	Cylinder Number							
9	Head Number							
10-13	Sector Number or Bytes from Index							

## 18.30 RELEASE (17)

Table 170: RELEASE (17)

Byte	Bit							
	7	6	5	4	3	2	1	0
0	Command Code = 17h							
1	Reserved = 0		3rdPty=0	3rd Party ID			Ext=0	
2	Reservation Identification							
3-4	Reserved = 0							
5	VU = 0		Reserved = 0			FLAG	LINK	

The RELEASE command is used to release a LUN previously reserved. It is not an error for an Initiator to release a LUN that is not currently active. The drive returns **Good** status without altering the reservation.

- **3rdPty** must be 0. Third Party reservations are not supported. If the 3rdPty bit is not zero, Check Condition status is returned with a sense key of Illegal Request and additional sense code of Invalid Field in CDB.
- **3rd Party ID** is ignored.
- **Extents** must be 0. Extension is not supported by the drive.
- **Reservation Identification** field is ignored.

## 18.31 RELEASE (57)

Table 171: RELEASE (57)

Byte	Bit							
	7	6	5	4	3	2	1	0
0	Command Code = 57h							
1	Reserved = 0		3rdPty=0	Reserved = 0			Ext = 0	
2	Reservation Identification							
3	3rd Party Device ID							
4-8	Reserved = 0							
9	VU = 0		Reserved = 0			FLAG	LINK	

The RELEASE command is used to release a LUN previously reserved. It is not an error for an Initiator to release a LUN that is not currently active. The drive returns **Good** status without altering the reservation.

- **3rdPty** must be 0. Third Party reservations are not supported. If the 3rdPty bit is not zero, Check Condition status is returned with a sense key of Illegal Request and additional sense code of Invalid Field in CDB.
- **3rd Party ID** is ignored.
- **Extent** must be 0. Extension is not supported by the drive.
- **Reservation Identification** field is ignored.



## 18.32 REPORT DEVICE IDENTIFIER (A3/05)

Table 172: REPORT DEVICE IDENTIFIER (A3/05)

Byte	Bit							
	7	6	5	4	3	2	1	0
0	Command Code = A3h							
1	Reserved = 0				Service Action = 05h			
2	Reserved = 0							
3	Reserved = 0							
4-5	(MSB) LUN=0 (LSB)							
6-9	(MSB) Allocation Length (LSB)							
10	Reserved = 0							
11	VU = 0		Reserved = 0				FLAG	LINK

The **REPORT DEVICE IDENTIFIER** command requests that the device server send device identification information to the application client.

The **LUN** contains the logical unit number parameter. This parameter is expected to be zero. Other value for this parameter will cause the command to terminate with a CHECK CONDITION status. The sense key is set to ILLEGAL REQUEST, and the additional sense code is set to INVALID FIELD IN CDB.

The **ALLOCATION LENGTH** field indicates how much space has been reserved for the returned parameter data. If the length is not sufficient to contain all the parameter data, the first portion of the data is returned. This is not considered an error. The actual length of the parameter data is available in the IDENTIFIER LENGTH field in the parameter data. If the remainder of the parameter data is required, the application client should send a new REPORT DEVICE IDENTIFIER command with an ALLOCATION LENGTH field large enough to contain all the data.

The REPORT DEVICE IDENTIFIER parameter list contains a 4-byte field that contains the length in bytes of the parameter list and the logical unit's identifier.

**Table 173: Report Device Identifier parameter list**

Byte	Bit							
	7	6	5	4	3	2	1	0
0-3	(MSB) Identifier Length = n - 3							(LSB)
4-n	Identifier							

The IDENTIFIER LENGTH field specifies the length in bytes of the IDENTIFIER field. If the ALLOCATION LENGTH field in the CDB is too small to transfer all of the identifier, the length is not adjusted to reflect the truncation. The identifier length initially equals zero and is changed only by a successful SET DEVICE IDENTIFIER command.

The IDENTIFIER field contains a vendor specific value. The value reported is the last value written by a successful SET DEVICE IDENTIFIER command. The value of the identifier is changed only by a SET DEVICE IDENTIFIER command. The identifier value persist through resets, power cycles, media format operations.

The Target return the same Identifier to all Initiators on all ports.

The execution of a REPORT DEVICE IDENTIFIER requires the enabling of a nonvolatile memory within the logical unit. If the nonvolatile memory is not ready, the device server returns **Check Condition** status rather than wait for the device to become ready. The sense key is set to *Not Ready* and the additional sense data is set as described in the TEST UNIT READY command. This information should allow the application client to determine the action required to cause the device server to become ready.

## 18.33 REPORT LUNS (A0)

Table 174: REPORT LUNS (A0)

Byte	Bit							
	7	6	5	4	3	2	1	0
0	Command Code = A0h							
1-5	Reserved							
6-9	(MSB) Allocation Length (LSB)							
10	Reserved							
11	VU = 0		Reserved = 0				FLAG	LINK

The REPORT LUNS command requests that the Target return the known LUN to the Initiator. The REPORT LUNS command should always be available and is unaffected by any reservations.

The Allocation Length must be at least 16 bytes. If the Allocation Length is less than 16 bytes, the Target will return a **Check Condition** status with sense key of *Illegal Request* and additional sense code of *Invalid Field in CDB*. If the Allocation Length is not sufficient to contain the LUN values for all configured logical units, the Target shall report as many LUN values as will fit in the specified Allocation Length. This is not considered an error.

The REPORT LUNS command will send the LUN list in the subsequent Data Out Phase. The format of the LUN list is shown in the following table.

Table 175: LUN Reporting parameter list format

Byte	Bit							
	7	6	5	4	3	2	1	0
0-3	(MSB) LUN List Length = 8 (LSB)							
4-7	Reserved							
8-15	(MSB) LUN = 0 (LSB)							

The LUN list length shall contain the length in bytes of the LUN list that is available to be transferred. This product only supports one LUN. Therefore, the LUN list length must be set to 8. The only supported LUN is zero.

## 18.34 REPORT SUPPORTED OPERATION CODES (A3/0C)

Table 176: REPORT SUPPORTED OPERATION CODES (A3/0C)

Byte	Bit							
	7	6	5	4	3	2	1	0
0	Command Code = A3h							
1	Reserved = 0				Service Action = 0Ch			
2	RCTD	Reserved = 0				Reporting Options		
3	Requested Operation Code							
4-5	Requested Service Action							
6-9	Allocation Length							
10	Reserved = 0							
11	VU = 0		Reserved			FLAG	LINK	

The REPORT SUPPORTED OPERATION CODES command requests information on commands that the drive supports. The initiator may request a list of all operation codes and service actions supported, or the command support data for a specific command.

**RCTD:** A return command timeouts descriptor (RCTD) bit set to one specifies that the command timeouts descriptor (see 6.24.4) shall be included in each command descriptor (see section 18.34.1) that is returned or in the one\_command parameter data (see section 18.34.2) that is returned. A RCTD bit set to zero specifies that the command timeouts descriptor shall not be included in any parameter data returned.

**Reporting Options** specifies the information to be returned in the parameter data.

Table 177: Reporting Options

Reporting Options	Description
000b	A list of all operation codes and service actions supported by the drive will be returned in the all_commands parameter data format. The Requested Operation Code field and Requested Service Action field will be ignored.
001b	The command support data for the operation code specified in the Requested Operation Code field will be returned in the one_command parameter data format. The Requested Service Action field will be ignored. If the Requested Operation Code field specifies an operation code that has service actions, Check Condition status will be reported with a sense key of Illegal Request and additional sense code of Invalid Field in CDB.
010b	The command support data for the operation code and service action specified in the Requested Operation Code field and Requested Service Action field will be returned in the one_command parameter data format. If the Requested Operation Code field specifies an operation code that does not have service actions, Check Condition status will be reported with a sense key of Illegal Request and additional sense code of Invalid Field in CDB.
011b-111b	Reserved

**Requested Operation Code** specifies the operation code of the command to be returned in the one\_command parameter data format.

**Requested Service Action** specifies the service action of the command to be returned in the one\_command parameter data format.

**Allocation Length** specifies the number of bytes that have been allocated for the returned parameter data. If the length is not sufficient to contain all the parameter data, the first portion of the data shall be returned. The actual length of the parameter data may be determined from the Additional Length field in the parameter data.

### 18.34.1 All\_commands parameter data format

The Report Supported Operation Codes all\_command parameter data format begins with a four-byte header that contains the length in bytes of the parameter data, followed by a list of supported commands. Each command descriptor contains information about a single supported command CDB (i.e. one operation code and service action combination, or one non-service action operation code).

**Table 178: All\_command parameter data format**

Byte	Bit							
	7	6	5	4	3	2	1	0
0-3	Command Data Length (n-3)							
4	Command Descriptor 0							
N	Command Descriptor X							

Each **Command Descriptor** contains information about a single supported command CDB.

**Table 179: Command Descriptor format**

Byte	Bit							
	7	6	5	4	3	2	1	0
0-3	Operation Code							
1	Reserved = 0							
2-3	Service Action							
4	Reserved = 0							
5	Reserved = 0						CTDP	Serva- ctv
6-7	CDB Length							
8-19	Command Timeouts Descriptor, if any (see 18.34.3)							

**Operation Code** contains the operation code of a supported command.

**Service Action** contains a supported service action of the supported operation. If the operation code does not have a service action, the Service Action field will be set to zero.

**CTDP:** A command timeouts descriptor present bit set to one indicates that the command timeouts descriptor (see 18.32.3) is included in this command descriptor. A CTDP bit set to zero indicates that the command timeouts descriptor is not included in this command descriptor.

**Servactv** set to zero indicates the operation code does not have service actions and the Service Action field should be ignored. **SERVACTV** set to one indicates the operation code field has service actions and the contents of the Service Action field are valid.

**CDB Length** contains the length of the command CDB in bytes.

### 18.34.2 One\_command parameter data format

The Report Supported Operation Codes one\_command parameter data format contains information about the CDB and a usage map for bits in the CDB for the command specified by the Reporting Options, Requested Operation Code, and Requested Service Action fields in the Reported Supported Operation Codes CDB.

**Table 180: One\_command parameter data format**

Byte	Bit							
	7	6	5	4	3	2	1	0
0	Reserved = 0							
1	CTDP	Reserved = 0				Support		
2-3	CDB Size (n-3)							
4-n	CDB Usage Data							
n+1 - n+12	Command Timeouts Descriptor, if any (see 18.34.3)							

**CTDP:** A command timeouts descriptor present bit set to one indicates that the command timeouts descriptor is included in this command descriptor. (see section 18.34.3) A CTDP bit set to zero indicates that the command timeouts descriptor is not included in this command descriptor.

The Support field is defined in the table below.

**Table 181: One\_command parameter support field**

Recording Option	Description
000b	Data about the requested command is not currently available. All data after byte 1 is not valid. A subsequent request for command support data may be successful.
001b	The requested command is not supported. All data after byte 1 is not valid.
010b	Reserved.
011b	The requested command is supported in conformance with the standard.
100b	Reserved
101b	The requested command is supported in a vendor specific manner.
110b-111b	Reserved.

**CDB Size** contains the size of the CDB Usage Data field in the parameter data, and the number of bytes in the CDB for the command requested.

**CDB Usage Data** contains information about the CDB for the command requested. The first byte of the CDB Usage Data field contains the operation code for the command. If the command contains a service action, then that service action code is returned in the same location as the Service Action field of the command CDB. All other bytes of the CDB Usage Data field contain a usage map for bits in the CDB for the command requested.

The bits in the usage map have a one-for-one correspondence to the CDB for the command requested. If the drive evaluates a bit in the CDB, the usage map will contain a one in the corresponding bit position. The usage map will contain a zero in the corresponding bit position for any field treated as ignored or reserved.

## 18.34.3 Command timeouts descriptor format

### 18.34.3.1 Overview

The command timeouts descriptor (see Table 182: ) returns time-out information for commands supported by the logical unit based on the time from the start of processing for the command to its reported completion. Values returned in the command timeouts descriptor do not include times that are outside the control of the device server (e.g., prior commands with the IMMED bit set to one in the CDB, concurrent commands from the same or different I\_T nexuses, manual unloads, power-on self tests, prior aborted commands, commands that force cache synchronization, delays in the service delivery subsystem). For commands that cause a change in power condition (Idle/Standby Powersave Modes), values returned in the command timeouts descriptor do not include the power condition transition time (e.g., the time to spinup rotating media). Values returned in the command timeouts descriptor should not be used to compare products.

**Table 182: Command timeouts descriptor format**

Byte	7	6	5	4	3	2	1	0
0 - 1	Descriptor Length (0Ah)							
2	Reserved = 0							
3	Command Specific							
4- 7	Nominal Command Processing Time-out							
8 - 11	Recommended Command Time-out							

The **DESCRIPTOR LENGTH** field indicates the number of bytes that follow in the command timeouts descriptor.

The **COMMAND SPECIFIC** field contains time-out information (see Table 183: ) that is specific to one or more commands. If no command specific time-out information is defined by this or the applicable command standard, the **COMMAND SPECIFIC** field is reserved.

**Table 183: Command timeouts descriptor Command Specific Field usage**

Command	Reference
WRITE BUFFER	See Section 18.34.3.2

### 18.34.3.2 WRITE BUFFER: command timeouts descriptor COMMAND SPECIFIC field usage

For the WRITE BUFFER command, the **COMMAND SPECIFIC** field usage is reserved for all modes except the following:

- Download microcode mode (04h);
- Download microcode and save mode (05h);
- Download microcode with offsets mode (06h);
- Download microcode with offsets and save mode (07h);
- Download microcode with offsets and defer activation mode (0Eh) only if the microcode is activated by an event other than an activate deferred microcode mode; and
- Activate deferred microcode mode (0Fh).

If the command timeouts descriptor describes one of the WRITE BUFFER modes listed in this subclause, then the **COMMAND SPECIFIC** field indicates the maximum time, in one second increments, that access to the SCSI device is limited or not possible through any SCSI ports associated with a logical unit that processes a WRITE BUFFER command that specifies one of the named modes. A value of zero in the **COMMAND SPECIFIC** field indicates that the no maximum time is indicated.



## 18.35 REPORT SUPPORTED TASK MANAGEMENT FUNCTIONS (A3/0D)

Table 184: Report Supported Task Management Functions (A3/0D)

Byte	Bit							
	7	6	5	4	3	2	1	0
0	Command Code = A3h							
1	Reserved = 0			Service Action = 0Dh				
2-5	Reserved = 0							
6-9	Allocation Length							
10	Reserved = 0							
11	VU = 0		Reserved = 0				Flag	Link

The REPORT SUPPORTED TASK MANAGEMENT FUNCTIONS command requests information on task management functions supported by the drive.

**Allocation Length** specifies the number of bytes that have been allocated for the returned parameter data. The allocation length must be at least four. If the allocation length is less than four, Check Condition Status will be returned with sense key of Illegal Request and additional sense code of Invalid Field in CDB.

The format of the returned parameter data is shown below.

Byte	Bit							
	7	6	5	4	3	2	1	0
0	ATS	ATSS	CACAS	CTSS	LURS	QTS	TRS	WAKES
1	Reserved					QUAS	QTSS	ITNRS
2	Reserved							
3	Reserved							

**ATS (Abort Task)** bit set to one indicates that ABORT TASK is supported. An ATS bit of zero indicates that ABORT TASK is not supported.

**ATSS (Abort Task Set)** bit set to one indicates that ABORT TASK SET is supported. An ATSS bit of zero indicates that ABORT TASK SET is not supported.

**CACAS (Clear ACA)** bit set to one indicates that CLEAR ACA is supported. A CACAS bit of zero indicates that CLEAR ACA is not supported.

**CTSS (Clear Task Set)** bit set to one indicates that CLEAR TASK SET is supported. A CTSS bit of zero indicates that CLEAR TASK SET is not supported.

**LURS (Logical Unit Reset)** bit set to one indicates that LOGICAL UNIT RESET is supported. An LUR bit of zero indicates that LOGICAL UNIT RESET is not supported.

**QTS (Query Task)** bit set to one indicates that QUERY TASK is supported. A QTS bit of zero indicates that QUERY TASK is not supported.

**TRS (Target Reset)** bit set to one indicates that TARGET RESET is supported. A TRS bit of zero indicates that TARGET RESET is not supported.

**WAKES (Wakeup)** bit set to one indicates that WAKEUP is supported. A WAKES bit of zero indicates that WAKEUP is not supported.

**A QUERY UNIT ATTENTION supported (QUAS)** bit set to one indicates the QUERY UNIT ATTENTION task management function (see SAM-4) is supported by the logical unit. A QUAS bit set to zero indicates the QUERY UNIT ATTENTION task management function is not supported.

**A QUERY TASK SET supported (QTSS)** bit set to one indicates the QUERY TASK SET task management function (see SAM-4) is supported by the logical unit. A QTSS bit set to zero indicates the QUERY TASK SET task management function is not supported.

**An I\_T NEXUS RESET supported (ITNRS)** bit set to one indicates the I\_T NEXUS RESET task management function (see SAM-4) is supported by the logical unit. An ITNRS bit set to zero indicates the I\_T NEXUS RESET task management function is not supported.

## 18.36 REQUEST SENSE (03)

Table 185: REQUEST SENSE (03)

Byte	Bit							
	7	6	5	4	3	2	1	0
0	Command Code = 03h							
1	Reserved = 0						DESC	
2-3	Reserved = 0							
4	Allocation Length							
5	VU = 0		Reserved = 0				FLAG	LINK

The REQUEST SENSE command requests the drive to transfer sense data.

The Descriptor Format (DESC) bit specifies which sense data format the device shall return in the parameter data. The Allocation Length specifies the maximum number of bytes of sense data that the drive should return. Such relationship is shown in the table below. (See 22.0, SCSI Sense Data for more details).

Table 186: Sense Data Format and Length

DESC Bit	Sense Data Format	Length of Sense Data Returned
0b	Fixed format	The number of bytes in the Allocation Length or 32 bytes, whichever is less
1b	Descriptor format	The number of bytes in the Allocation Length or a fixed "descriptor sense data size", whichever is less. The "descriptor sense data size" is either 40 or 60 bytes, depending on the drive firmware build.

If REQUEST SENSE command with an invalid LUN is received, the drive returns **Good** status and reports a sense key of *Illegal Request* and an additional sense code of *Logical Unit Not Supported*.

If the drive has no sense data available to return, it will return a sense key of *No Sense* and an additional sense code of *No Additional Sense Information*.

Separate sense data is maintained by the device for each Initiator. Therefore, there is no requirement for an Initiator to expeditiously clear a *Check Condition* as this will not affect other initiators in a multi-Initiator system.

## 18.37 RESERVE (16)

Table 187: RESERVE (16)

Byte	Bit							
	7	6	5	4	3	2	1	0
0	Command Code = 16h							
1	Reserved = 0		3rdPty=0	3rd Party ID			Ext=0	
2	Reservation Identification							
3-4	(MSB) Extent List Length = 0 (LSB)							
5	VU = 0		Reserved = 0			FLAG	LINK	

The RESERVE command is used to reserve a LUN for an Initiator. This reservation can be either for the Initiator sending the command or for a third party as specified by the Initiator.

Extents are not supported by the drive. The Ext bit must be zero. If Ext bit is set to one, **Check Condition** status is returned with a sense key of *Illegal Request* and additional sense code of *Invalid Field in CDB*. The Reservation Identification and Extent List Length fields are ignored.

The Reserve command requests that the entire LUN be reserved for the Initiator until

- the reservation is superseded by another valid Reserve command from the Initiator that made the reservation.
- the reservation is released by a RELEASE command from the same Initiator.
- a hard Reset condition occurs.
- a Target Reset message is received from any Initiator.
- a power off/on cycle occurs.

**3rdPty** must be 0. Third Party reservations are not supported. If the 3rdPty bit is not zero, Check Condition status is returned with a sense key of *Illegal Request* and additional sense code of *Invalid Field in CDB*.

**3rd Party ID** is ignored.

Only the Initiator that issued the Reserve command for a LUN may release the LUN, regardless of the 3rdPty option. This Initiator may also release the LUN by issuing another RESERVE command. This superseding RESERVE command releases the previous reservation when the new reservation is granted.

Reservation queuing is not supported by the drive. If a LUN is reserved and a RESERVE command is issued from a different Initiator, the Target responds with a RESERVATION CONFLICT.

## 18.38 RESERVE (56)

Table 188: RESERVE (56)

Byte	Bit							
	7	6	5	4	3	2	1	0
0	Command Code = 56h							
1	Reserved = 0		3rdPty=0		Reserved		Ext=0	
2	Reservation Identification							
3	Third Pay Device ID							
4-6	Reserved = 0							
7-8	(MSB) Extent List Length = 0							(LSB)
9	VU = 0		Reserved = 0			FLAG	LINK	

The RESERVE command is used to reserve a LUN for an Initiator. This reservation can be either for the Initiator sending the command or for a third party as specified by the Initiator.

Extents are not supported by the drive. The Ext bit must be zero. If Ext bit is set to one, **Check Condition** status is returned with a sense key of *Illegal Request* and additional sense code of *Invalid Field in CDB*. The Reservation Identification and Extent List Length fields are ignored.

The Reserve command requests that the entire LUN be reserved for the Initiator until

- the reservation is superseded by another valid Reserve command from the Initiator that made the reservation.
- the reservation is released by a RELEASE command from the same Initiator.
- a hard Reset condition occurs.
- a Target Reset message is received from any Initiator.
- a power off/on cycle occurs.

**3rdPty** must be 0. Third Party reservations are not supported. If the 3rdPty bit is not zero, Check Condition status is returned with a sense key of *Illegal Request* and additional sense code of *Invalid Field in CDB*.

**3rd Party ID** is ignored.

Only the Initiator that issued the Reserve command for a LUN may release the LUN, regardless of the 3rdPty option. This Initiator may also release the LUN by issuing another RESERVE command. This superseding RESERVE command releases the previous reservation when the new reservation is granted.

Reservation queuing is not supported by the drive. If a LUN is reserved and a RESERVE command is issued from a different Initiator, the Target responds with a RESERVATION CONFLICT.

## 18.39 REZERO UNIT (01)

Table 189: REZERO UNIT (01)

Byte	Bit							
	7	6	5	4	3	2	1	0
0	Command Code = 01h							
1	Reserved = 0			Reserved = 0				
2-4	Reserved = 0							
5	VU = 0		Reserved = 0				FLAG	LINK

The REZERO UNIT command requests that the Target seek LBA 0.

## 18.40 SEND DIAGNOSTIC (1D)

Table 190: SEND DIAGNOSTIC (1D)

Byte	Bit							
	7	6	5	4	3	2	1	0
0	Command Code = 1Dh							
1	Function Code			PF	RSVD =0	SIfTst	Dev0fl	Unt0fl
2	Reserved = 0							
3-4	(MSB) Parameter List Length							(LSB)
5	VU = 0		Reserved = 0				FLAG	LINK

The SEND DIAGNOSTIC command requests the drive to perform its self-diagnostic test or to perform a function based on a page of information sent in a Data Out phase during the command.

- **PF (Page Format)** bit set to one indicates the data sent by the Initiator conform to the page structure as specified in SCSI standard. This bit is ignored by the Target if the SIfTst bit is set.
- **SIfTst** set to one indicates that the device performs its default self-test. If SIfTst is one, the Function code field is ignored. If SIfTst is set to zero, the action to perform is specified in Function code field.

**Table 191: SEND DIAGNOSTIC Function Code (1D)**

Value	Function name	Description
000b	NA	Value to be used when the SlfTst bit is set to one or if the SEND DIAGNOSTIC command is not invoking one of the other self-test function codes.
001b	Background Short self-test	The device server starts its short self-test routine in background mode.
010b	Background extended self-test	The device server starts its extended self-test routine in background mode.
011b	NA	Reserved.
100b	Abort background self-test	Abort the current self-test in the background mode. This value is only valid if a previous SEND DIAGNOSTIC command specified a background self-test function and that function has not been completed.
101b	Foreground short self-test	The device server starts its short self-test routine in the foreground mode. This self-test will complete in two minutes or less.
110b	Foreground extended self-test	The device server starts its extended self-test routine in the foreground mode .The completion time for this test is reported in Mode Page 0Ah (refer to section 17.11.9 "Mode Page 0A).
111b		Reserved.

- **DevOffl** is ignored by the Target for compatibility.
- **UntOffl** is ignored by the Target for compatibility.
- **Parameter List Length** must be 0 when the SlfTst bit is one. Otherwise, **Check Condition** status will be generated with a sense key of *Illegal Request* and additional sense of *Invalid Field in CDB*. If the SlfTst bit is zero, it should be set to the length of the page to be transferred in the DATA OUT phase of the command. If it does not match the expected length of the page a **Check Condition** status will be also generated with a sense key of *Illegal Request* and additional sense of *Invalid Field in CDB*.

If the motor is not running at the correct speed when the command is received, it is rejected by a **Check Condition** status with a *Not Ready* sense key.

If a fault is detected during the default or foreground self-test, a **Check Condition** is reported as an end status. If a fault is detected during the background self-test, it is logged in the log page for later retrieval by a LOG SENSE command.

See Section 21.19 "Diagnostics" on page 292 for a detailed listing of operations carried out by the SEND DIAGNOSTIC command and Power on Diagnostics.



## 18.40.1 Send Diagnostic Page 0

This page requests that the drive return a list of supported pages on the next RECEIVE DIAGNOSTICS command.

**Table 192: Diagnostic Page 0**

Byte	Bit							
	7	6	5	4	3	2	1	0
0	Page Code = 0							
1	Reserved = 0							
2 - 3	Page Length = 0							

## 18.40.2 Send Diagnostic Page 3F

**Table 193: Diagnostic Page 3F**

Byte	Bit							
	7	6	5	4	3	2	1	0
0	Page Code = 3F							
1	Reserved = 0				Protocol Identifier = 6			
2 - 3	Page Length = 1Ch							
4	Phy Identifier							
5	Phy Test Function							
6	Phy Test Pattern							
7	Rsvd=0	Phy Test Pattern SATA = 0	Phy Test Pattern SSC		Phy Test Pattern Physical Link Rate			
8 - 10	Reserved = 0							
11	Phy Test Pattern Dwords Control							
12 - 19	Phy Test Pattern Dwords							
20 - 31	Reserved = 0							

- Phy Identifier specifies the selected phy that is to perform or to stop performing a phy test function. If the phy does not exist, Check Condition status will be returned with a sense key of Illegal Request and additional sense of Invalid Field in Parameter List.
- Phy Test Function specifies the phy test function to be performed. If an unsupported function is requested, Check Condition status will be returned with a sense key of Illegal Request and additional sense of Invalid Field in Parameter List.

Phy Test Function	Description
<b>00h</b>	If the selected phy is performing a phy-test function, then the selected phy stop performing the phy test function and originate a link reset sequence. If the selected phy is not performing a phy test function, then this function as no effect on the selected phy.
<b>01h</b>	If the selected phy is not performing a phy test function, the selected phy will be set to transmit the phy test pattern specified by the Phy Test Pattern field at the physical link rate specified by the Phy Test Pattern Physical
<b>02h-FDh</b>	Unsupported
<b>FEh</b>	Analog Loopback - If the selected phy is not performing a phy test function, the selected phy will be set to retransmit the data pattern received by the phy receiver without retime
<b>FFh</b>	Retime Loopback- If the selected phy is not performing a phy test function, the selected phy will be set to retransmit the retimed data pattern received by the phy receiver

- **Phy Test Pattern** specifies the phy test pattern to be transmitted when the Phy Test Function is set to 01h. If an unsupported value is specified, Check Condition status will be returned with a sense key of Illegal Request and additional sense of Invalid Field in Parameter List.

Phy Test Pattern	Description
00h	Reserved
01h	JTPAT
02h	CJTPAT
03h-0Fh	Reserved
10h	TRAIN
11h	TRAIN_DONE
13h	SCRAMBLE_0
12h	IDLE
14h - 3Fh	Reserved
40h	TWO_DWORDS
41h - EFh	Reserved
F0h	PRBS7 (DC un-balanced version)
F1h-FFh	Reserved

- **Phy Test Pattern Physical Link Rate** specifies the physical link rate at which the phy test pattern shall be transmitted. Supported values are 8h for 1.5 Gbps, 9h for 3.0 Gbps, and Ah for 6.0 Gbps. If an unsupported value is specified, Check Condition status will be returned with a sense key of Illegal Request and additional sense of Invalid Field in Parameter List.
- **Phy Test Pattern SATA** bit set to 0 indicates that the phy transmits the phy test pattern as a SAS phy. If this bit is set to 1, Check Condition status will be returned with a sense key of Illegal Request and additional sense of Invalid Field in Parameter List
- **Phy Test Pattern SSC** field specifies the SSC modulation type which the phy test pattern will be transmitted. If an unsupported SSC modulation type is specified, Check Condition status will be returned with a sense key of Illegal Request and additional sense of Invalid Field in Parameter List.

Phy Test Pattern SSC Code	Description
00h	No SSC
01h	Center-spreading SSC (Not supported)
10h	Down-spreading SSC
11h	Reserved

- **Phy Test Pattern Dwords Control** controls whether the bytes in the Phy Test Pattern Dwords field are sent as control characters or data characters.

Phy Test Pattern Dwords Control	Description
00h	Each byte in the Phy Test Pattern Dwords field shall be sent as a data character (i.e., Dxx.y) without scrambling.
08h	The fifth byte in the Phy Test Pattern Dwords field shall be sent as a control character (i.e., Kxx.y). Each other byte shall be sent as a data character without scrambling.
80h	The first byte in the Phy Test Pattern Dwords field shall be sent as a control character. Each other byte shall be sent as a data character without scrambling.
88h	The first and fifth bytes in the Phy Test Pattern Dwords field shall be sent as a control character. Each other byte shall be sent as a data character without scrambling.
All others	Reserved

- **Phy Test Pattern Dwords** contains the two Dwords that are sent during a TWO\_DWORDS test pattern.

### 18.40.3 Send Diagnostic Page 40

This allows the Initiator to translate a LBA or physical sector address to the other format. The address to be translated is passed to the Target with the SEND DIAGNOSTIC command and the results are returned to the Initiator by the RECEIVE DIAGNOSTICS command.

The Target will read the parameter list from the Initiator, and, if no errors are detected in the parameter list, **Good** status will be returned. The data translation will be performed upon receipt of the RECEIVE DIAGNOSTICS command.

**Table 194: Diagnostic Page 40**

Byte	Bit							
	7	6	5	4	3	2	1	0
0	Page Code = 40h							
1	Reserved = 0							
2-3	Page Length = 0Ah							
4	Reserved = 0					Supplied Format		
5	Reserved = 0					Translate Format		
6-13	Address to Translate							

**Supplied Format** may take one of the following three values:

- 000b** Short Block format
- 011b** Long Block format
- 100b** Bytes From Index format
- 101b** Physical Sector format

It specifies the format in which the address has been supplied.

- **Translate Format** specifies the format that the address should be translated into. If the Supplied Format is the Short Block format or Long Block format, the Translate format must be either Bytes From Index or Physical Sector format. If the Supplied Format is the Bytes From Index or Physical Sector format, the Translate Format must be Long Block format. If either of the format fields is invalid or they specify the same format, the command will terminate with **Check Condition** status with a sense code of *Illegal Request* and *Illegal Field in Parameter List*.
- **Address to Translate** contains the address to translate. If the Short Block format is specified, the first four bytes of the field (bytes 6 to 9) contain the LBA and the remainder must be zero. If the Long Block format is specified, byte 6 to 13 contain the 64-bit LBA. For the physical format the address must be specified as follows.

**Table 195: Address to translate**

Byte	Bit							
	7	6	5	4	3	2	1	0
6-8	Cylinder Number							
9	Head Number							
10-13	Sector Number or Bytes from Index							

## 18.41 SET DEVICE IDENTIFIER (A4/06)

Table 196: SET DEVICE IDENTIFIER (A4/06)

Byte	Bit							
	7	6	5	4	3	2	1	0
0	Command Code = A4h							
1	Reserved = 0				Service Action = 06h			
2	Reserved = 0							
3	Reserved = 0							
4-5	Restricted = 0							
6-9	(MSB) Parameter List Length (LSB)							
10	Reserved = 0							
11	VU = 0		Reserved = 0				FLAG	LINK

The SET DEVICE IDENTIFIER command requests that the device identifier information be set to the value received in the SET DEVICE IDENTIFIER parameter list.

On successful completion of a SET DEVICE IDENTIFIER command a unit attention is generated for all Initiators except the one that issued the service action. When reporting the unit attention condition the additional sense code is set to *Device Identifier Changed*.

- **Parameter List Length** field specifies the length in bytes of the Identifier that is transferred from the host system to the Target. The maximum value for this field is 512 bytes. A parameter list length of zero indicates that no data is transferred, and that subsequent REPORT DEVICE IDENTIFIER commands return an Identifier length of zero.

The SET DEVICE IDENTIFIER parameter list contains the identifier to be set by the addressed logical unit.

Table 197: SET DEVICE IDENTIFIER, Parameter List

Byte	Bit							
	7	6	5	4	3	2	1	0
0-n	Identifier							

The IDENTIFIER field is a vendor specific value, to be returned in subsequent REPORT DEVICE IDENTIFIER commands.

## 18.42 START STOP UNIT (1B)

Table 198: START STOP UNIT (1B)

Byte	Bit							
	7	6	5	4	3	2	1	0
0	Command Code = 1Bh							
1	Reserved = 0							Immed
2	Reserved = 0							
3	Reserved = 0				Power Condition Modifier			
4	Power Condition				Reserved=0		LoEj = 0	Start
5	VU = 0		Reserved = 0				FLAG	LINK

The START STOP UNIT command is used to spin up or stop the spindle motor.

- **Immed** bit is to specify
  - 0** status is to be returned at the end of the operation.
  - 1 Good** status shall always be returned immediately after command has been received. The TEST UNIT READY command may be used to determine when the drive becomes ready after a spin-up.
- **Power Conditions and Power Condition Modifier** fields are used to specify that the logical unit be placed into a power condition or to adjust a timer as defined in Table 199, If this field is set to a value other than 0h, then the START bit shall be ignored.

**Table 199: Power Conditions:**

<b>Power Condition Code</b>	<b>Name</b>	<b>Power Condition Modifier</b>	<b>Description</b>
0h	START_VALID	0h	Process the START bit
1h	ACTIVE	0h	Place the device into the active power condition
2h	IDLE_A	0h	Place the device into the idle-a power condition
2h	IDLE_B	1h	Place the device into the idle-b power condition
2h	IDLE_C	2h	Place the device into the idle-c power condition
3h	STANDBY_Z	0h	Place the device into the standby_Z power condition
3h	STANDBY_Y	1h	Place the device into the standby_Y power condition
4h	Reserved	0h	Reserved
5h	Obsolete	0h-Fh	Obsolete
6h	Reserved	0h	Reserved
7h	LU_CONTROL	0h	Transfer control of power conditions to the logical unit
8h - 9h	Reserved	0h	Reserved
Ah	FORCE_IDLE_A	0h	Force the idle_a condition timer to zero.
Ah	FORCE_IDLE_B	1h	Force the idle_b condition timer to zero.
Ah	FORCE_IDLE_C	2h	Force the idle_c condition timer to zero.
Bh	FORCE_STANDBY_Z	0h	Force the standby_z condition timer to zero.
Bh	FORCE_STANDBY_Y	1h	Force the standby_y condition timer to zero.
all Others	Reserved	0h	Reserved

If the START STOP UNIT command is processed with the POWER CONDITION field set to ACTIVE, IDLE, or STANDBY, then:

- a) the logical unit shall transition to the specified power condition; and
- b) the device server shall disable the idle condition timer if it is active and disable the standby condition timer if it is active until another START STOP UNIT command is processed that returns control of the power condition to the logical unit, or a logical unit reset occurs.
- c) if under initiator control, the two minute floor and 60 head unloads per 24 hour period limits do not apply as they do when under logical unit/timer control

If the START STOP UNIT command is processed with the POWER CONDITION field set to LU\_CONTROL, then the device server shall initialize and start all of the idle condition timers and standby condition timers that are supported and enabled.

If the START STOP UNIT command is processed with the POWER CONDITION field set to LU\_CONTROL, then the device server shall enable the idle condition timer if it is active and disable the standby condition timer if it is active.



If the START STOP UNIT command is processed with the POWER CONDITION field set to FORCE\_IDLE\_0 or FORCE\_STANDBY\_0, then the device server shall:

- a) force the specified timer to zero, cause the logical unit to transition to the specified power condition, and return control of the power condition to the device server; or
- b) terminate a START STOP UNIT command that selects a timer that is not supported by the device server or a timer that is not active. The device server shall terminate the command with CHECK CONDITION status with the sense key set to ILLEGAL REQUEST and the additional sense code set to INVALID FIELD IN CDB.

It is not an error to specify that the logical unit transition to its current power condition. See Mode Page 1A (Power Control) for more information on idle and standby power conditions.

• **LoEj** is not supported by the drive and must be set to 0.

- **Start** bit is to specify:

<b>0</b>	stop the spindle
<b>1</b>	start the spindle

**Note:** Once the drive has become ready (after a power on), the START STOP UNIT command can be used without any errors regardless of the state of the motor: stopped or spinning.

## 18.43 SYNCHRONIZE CACHE (10) - (35)

Table 200: SYNCHRONIZE CACHE (10) - (35)

Byte	BIT							
	7	6	5	4	3	2	1	0
0	Command Code = 35h							
1	Reserved = 0			Reserved = 0			Immed = 0	Obsolete
2-5	(MSB) Logical Block Address (LSB)							
6	Reserved = 0							
7-8	(MSB) Number of Blocks (LSB)							
9	VU = 0	Reserved = 0				FLAG	LINK	

The SYNCHRONIZE CACHE command ensures that logical blocks in the cache have their most recent data value recorded on the media.

- **Logical Block Address** is to specify where the operation is to begin.
- **Immed** (immediate) must be zero. An immediate bit of zero indicates that the status shall not be returned until the operation has completed. If the Immed bit is set to one, the drive returns a **Check Condition** status. The sense key shall be set to *Illegal Request* and the additional sense code shall be set to *Invalid Field in CDB*.
- **Number of Blocks** specifies the total number of contiguous logical blocks within the range. Number of Blocks of zero indicates that all remaining logical blocks on the logical unit shall be within the range.

## 18.44 SYNCHRONIZE CACHE (16) - (91)

Table 201: Synchronize Cache (16) - (91)

Byte	BIT							
	7	6	5	4	3	2	1	0
0	Command Code = 91h							
1	Reserved = 0						Immed = 0	Rsvd= 0
2-9	Logical Block Address							
10-13	Number of Blocks							
14	Reserved = 0							
15	VU = 0		Reserved = 0				FLAG	LINK

The SYNCHRONIZE CACHE command ensures that logical blocks in the cache have their most recent data value recorded on the media. See the SYNCHRONIZE CACHE (10) description for definitions of the fields in this command.

## 18.45 TEST UNIT READY (00)

Table 202: TEST UNIT READY (00)

Byte	Bit							
	7	6	5	4	3	2	1	0
0	Command Code = 00h							
1	Reserved = 0			Reserved = 0				
2-4	Reserved = 0							
5	VU = 0		Reserved = 0			FLAG		LINK

The TEST UNIT READY command allows the Initiator to check if the drive is READY. The SCSI specification defines READY as the condition where the device will accept a media-access command without returning **Check Condition** status.

The drive will first verify that the motor is spinning at the correct speed. If the spindle motor is not spinning at the correct speed, **Check Condition** status is returned with sense key of *Not Ready*. If the motor is spinning at the correct speed, the drive accepts normal media access commands.

The TEST UNIT READY command is not intended as a diagnostic. No self diagnostic is performed by the device as a result of this command.

The TEST UNIT READY command has special significance for power sequencing using the UNIT START command with an Immediate bit of one. In this mode the UNIT START command returns **Task Complete** status before the completion of motor spin-up and expects the initiator to issue TEST UNIT READY commands to determine when the motor has reached the proper speed.

**Note:** The spindle automatically starts in automatic spin-up mode. The drive does not execute any commands other than TEST UNIT READY, INQUIRY, or REQUEST SENSE command until the Power On sequence is complete. The drive will return **Check Condition** status with *Not Ready* sense key and *In Process of Becoming Ready* sense code for all other commands during the Power On period.

## 18.46 VERIFY (10) (2F)

Table 203: VERIFY (10)(2F)

Byte	BIT							
	7	6	5	4	3	2	1	0
0	Command Code = 2Fh							
1	VRPROTECT		DPO	Reserved = 0			Byte Chk	RSVD = 0
2-5	(MSB) Logical Block Address (LSB)							
6	Reserved = 0							
7-8	(MSB) Verification Length (LSB)							
9	VU = 0		Reserved = 0			FLAG	LINK	

The VERIFY command requests that the drive verify the data written on the media. A verification length of zero indicates that no data will be transferred. This condition is not considered an error.

- ByteChk** bit set to zero indicates that the data is read from the disk and verified using LDPC. If an LDPC error is detected in the verify process, **Check Condition** status is returned with sense key set to *Medium Error*. ByteChk bit set to one indicates that byte-by-byte comparison is performed between the data on the disk and data transferred from the initiator during the data-out phase.

If the comparison is unsuccessful, the command is terminated with **Check Condition** status and the sense key is set to *Miscompare*.
- DPO** (Disable Page Out) bit of one indicates that the data accessed by this command is to be assigned the lowest priority for being written into or retained by the cache. A DPO bit of one overrides any retention priority specified in the Mode Select Page 8 Caching Parameters. A DPO bit of zero indicates the priority is determined by the retention priority. The Initiator should set the DPO bit when the blocks read by this command are not likely to be read again in the near future.

If caching is enabled, the command performs an implied FUA and an implied Synchronize Cache before starting the VERIFY. This ensures that the medium, not the cache, is being verified.

The command stops on *Check Condition* and reports the LBA in error. The command must be reissued, starting with the next LBA, to verify the remainder of the Drive.

The Verification Length is the number of blocks to check.

The data (if any) from the data-out phase and the data from the media are not retained in the cache. Therefore, the DPO bit has no effect on this command and is ignored.

VRPROTECT defines the manner in which protection information read from disk shall be checked during processing of the command. Protection information is stored on disk, and may be validated using the drive's internal checking algorithms, and also byte-by-byte compared using data from the initiator when ByteChk=1.

If the drive is not formatted with protection information, VRPROTECT must be set to 000b, else Check Condition status will be returned with sense key of Illegal Request and additional sense code of Invalid Field in CDB.

VRPROTECT=000b

If the drive is not formatted with protection information, only user data is verified.

If the drive is formatted with protection information:

- Logical Block Guard is checked
- Logical Block Application Tag is checked (applies to VERIFY(32) command only)
- Logical Block Reference Tag is checked

VRPROTECT=001b

- Logical Block Guard is checked
- Logical Block Application Tag is checked (applies to VERIFY(32) command only)
- Logical Block Reference Tag is checked

VRPROTECT=010b

- Logical Block Guard is not checked
- Logical Block Application Tag is checked (applies to VERIFY(32) command only)
- Logical Block Reference Tag is checked

VRPROTECT=011b

- Logical Block Guard is not checked
- Logical Block Application Tag is not checked
- Logical Block Reference Tag is not checked

VRPROTECT=100b

- Logical Block Guard is checked
- Logical Block Application Tag is not checked
- Logical Block Reference Tag is not checked

VRPROTECT=101b, 110b, 111b

These values are reserved. Check Condition status will be returned with sense key of Illegal Request and additional sense code of Invalid Field in CDB.

If a check of the protection information fails, Check Condition status will be returned with sense key of Aborted Command and additional sense code indicating which protection field check failed.

If ByteChk=1, the drive's internal checking of protection information is done only when VRPROTECT=000b and the drive is formatted with protection information

If ByteChk=1, and VRPROTECT is not set to 000b, checking of protection information is performed on the fields described above as a byte-by-byte comparison against the data transferred to the drive by the initiator during the Data Out phase.

Refer to the ANSI T10 standards for additional details of protection information.

## 18.47 VERIFY (12) - (AF)

Table 204: Verify (12) - (AF)

Byte	BIT							
	7	6	5	4	3	2	1	0
0	Command Code = AFh							
1	VRPROTECT		DPO	FUA	Reserved=0	Byte Chk	Reserved = 0	
2-5	(MSB) Logical Block Address (LSB)							
6-9	(MSB) Verification Length (LSB)							
10	Reserved = 0							
11	VU = 0		Reserved = 0			FLAG	LINK	

The VERIFY(12) command causes the drive to verify data written on the media. See the VERIFY(10) description for the definitions of the fields in this command.



## 18.48 VERIFY (16) - (8F)

Table 205: Verify (16) - (8F)

Byte	Bit							
	7	6	5	4	3	2	1	0
0	Command Code = 08Fh							
1	VRPROTECT		DPO	Reserved = 0			Byte Chk	Rsvd = 0
2-9	(MSB) Logical Block Address							(LSB)
10-13	(MSB) Verification Length							(LSB)
14	Reserved = 0							
15	VU = 0		Reserved = 0			FLAG	LINK	

The VERIFY command requests that the drive verify the data written on the media. See the VERIFY (10) description for the definitions of the fields in this command.

## 18.49 VERIFY (32) - (7F/0A)

Table 206: Verify (32) - 7F/0A)

Byte	Bit							
	7	6	5	4	3	2	1	0
0	Command Code = 07Fh							
1	VU = 0		Reserved = 0				FLAG	LINK
2-5	Reserved = 0							
6	Reserved = 0			Group Number = 0				
7	Additional CDB Length = 18h							
8 - 9	Service Action = 000Ah							
10	RDPROTECT			DPO	Reserved = 0		ByteC hk	Reserv ed=0
11	Reserved = 0							
12 - 19	(MSB) Logical Block Address (LSB)							
20 - 23	(MSB) Expected Initial Logical Block Reference Tag (LSB)							
24 - 25	(MSB) Expected Logical Block Application Tag (LSB)							
26 - 27	(MSB) Logical Block Application Tag Mask (LSB)							
28 - 31	(MSB) Verification Length (LSB)							

The VERIFY command requests that the verify the data written on the media. Each logical block includes user data and may include protection information, based on the VPROTECT field and the drive format.

If the drive is formatted with type 2 protection (PROT\_EN=1 and P\_TYPE=001b in the READ CAPACITY (16) parameter data), then this command will be processed normally. Any other protection types will result in Check Condition status to be returned with sense key of Illegal Request and additional sense code of Invalid Command Operation Code

The Expected Initial Logical Block Reference Tag field contains the value of the Logical Block Reference Tag field expected in the protection information of the first logical block accessed by the command.

If the ATO bit is set to one in Mode Page 0Ah, the Logical Block Application Tag Mask field contains a value that is a bit mask for enabling the checking of the Logical Block Application Tag field in the protection information for each logical block accessed by the command. A Logical Block Application Tag Mask bit set to one enables the checking of the corresponding bit of the Expected Logical Block Application Tag field with the corresponding bit of the Logical Block Application Tag field in the protection information.

If the ATO bit is set to zero, the Logical Block Application Tag Mask field and the Expected Logical Block Application Tag field are ignored.

## 18.50 WRITE (6) - (0A)

Table 207: WRITE (6) - (0A)

Byte	Bit								
	7	6	5	4	3	2	1	0	
0	Command Code = 0Ah								
1	Reserved = 0			(MSB)				LBA	
2-3	Logical Block Address							(LSB)	
4	Transfer Length								
5	VU = 0		Reserved = 0				FLAG	LINK	

The WRITE command requests the drive to write the specified number of blocks of data (**Transfer Length**) from the Initiator to the medium starting at the specified **Logical Block Address (LBA)**.

See Section 18.16 READ (6) - (08)” on page 181 for the parameters.

## 18.51 WRITE (10) - (2A)

Table 208: WRITE (10) - (2A)

Byte	Bit							
	7	6	5	4	3	2	1	0
0	Command Code = 2Ah							
1	WRPROTECT			DPO	FUA	Rsvd=0	FUA_NV	Obsolete
2-5	(MSB) Logical Block Address (LSB)							
6	Reserved = 0							
7-8	(MSB) Transfer Length (LSB)							
9	VU = 0	Reserved = 0				FLAG	LINK	

The WRITE (10) command requests that the drive write the data transferred from the Initiator. This command is processed like the standard WRITE (6) - (0A) command except for the longer transfer length.

- **Transfer Length** is the number of contiguous blocks to be transferred. If the transfer length is zero, the seek occurs, but no data is transferred. This condition is not considered an error.
- **DPO** (Disable Page Out) bit of one indicates that the data accessed by this command is to be assigned the lowest priority for being written into or retained by the cache. A DPO bit of one overrides any retention priority specified in the Mode Select Page 8 Caching Parameters. A DPO bit of zero indicates that the priority is determined by the retention priority. The Initiator should set the DPO bit when the blocks written by this command are not likely to be read in the near future.
- **FUA** (Force Unit Access) bit of one indicates that the Target must write the data to the media before returning **Good** status. A FUA bit of zero indicates that the Target may return **Good** status prior to writing the data to the media.
- **FUA\_NV** (Force Unit Access Non-Volatile Cache) may be set to 0 or 1, but is ignored since NV\_SUP=0 in Inquiry Page 86h.

If a WRITE(6) command is received after protection information is enabled, the drive will set the protection information as follows as it writes each block to disk:

- the Logical Block Guard field is set to a properly generated CRC
- the Logical Block Reference Tag field is set to:
  - the least significant four bytes of the LBA, if the drive is formatted with type 1 protection (PROT\_EN=1 and P\_TYPE=000b in the READ CAPACITY (16) parameter data); or
  - FFFFFFFFh, if the drive is formatted with type 2 protection (PROT\_EN=1 and P\_TYPE=001b in the READ CAPACITY (16) parameter data)
- the Logical Block Application Tag field is set to
  - FFFFh, if the ATO bit is set to one in Mode Page 0Ah; or
  - Any value, if the ATO bit is set to zero

**WRPROTECT** defines the manner in which protection information written to disk shall be checked during processing of the command. Protection information may be transmitted to the drive with the user data, based on the WRPROTECT bit and the drive format.

If the drive is not formatted with protection information, WRPROTECT must be set to 000b, else Check Condition status will be returned with sense key of Illegal Request and additional sense code of Invalid Field in CDB.

WRPROTECT=000b

Protection information is not transmitted to the drive.

If the drive is formatted with protection information, the drive will write protection information to disk based on its internal algorithms.

WRPROTECT=001b

- Protection information is transmitted to the drive with the user data
- Logical Block Guard is checked
- Logical Block Application Tag is checked (applies to WRITE (32) command only)
- Logical Block Reference Tag is checked

WRPROTECT=010b

- Protection information is transmitted to the drive with the user data
- Logical Block Guard is not checked
- Logical Block Application Tag is checked (applies to WRITE(32) command only)
- Logical Block Reference Tag is checked

WRPROTECT=011b

- Protection information is transmitted to the drive with the user data
- Logical Block Guard is not checked
- Logical Block Application Tag is not checked
- Logical Block Reference Tag is not checked

WRPROTECT=100b

- Protection information is transmitted to the drive with the user data
- Logical Block Guard is checked
- Logical Block Application Tag is not checked
- Logical Block Reference Tag is not checked

WRPROTECT=101b, 110b, 111b

These values are reserved. Check Condition status will be returned with sense key of Illegal Request and additional sense code of Invalid Field in CDB.

If a check of the protection information fails, Check Condition status will be returned with sense key of Aborted Command and additional sense code indicating which protection field check failed.

Refer to the ANSI T10 standards for additional details of protection information.

## 18.52 WRITE (12) - (AA)

Table 209: Write (12) - (AA)

Byte	Bit							
	7	6	5	4	3	2	1	0
0	Command Code = AAh							
1	WRPROTECT			DPO	FUA	Rsvd=0	FUA_NV	Rsvd=0
2-5	(MSB) Logical Block Address (LSB)							
6-9	(MSB) Transfer Length (LSB)							
10	Reserved=0							
11	VU = 0		Reserved = 0				FLAG	LINK

The WRITE(12) command causes the drive to write data from the initiator to the media. See the WRITE(10) description for the definitions of the fields in this command.



## 18.53 WRITE (16) - (8A)

Table 210: Write (16) - (8A)

Byte	Bit							
	7	6	5	4	3	2	1	0
0	Command Code = 8Ah							
1	WRPROTECT			DPO	FUA	Rsvd=0	FUA_NV	Rsvd=0
2-9	(MSB) Logical Block Address (LSB)							
10-13	(MSB) Transfer Length (LSB)							
14	Reserved = 0							
15	VU = 0		Reserved = 0				FLAG	LINK

The WRITE(16) command causes the drive to write data from the initiator to the media. See the WRITE(10) description for the definitions of the fields in this command.

## 18.54 WRITE (32) - (7F/0B)

Table 211: Write (32) - (7F/0B)

Byte	Bit							
	7	6	5	4	3	2	1	0
0	Command Code = 7Fh							
1	VU = 0		Reserved = 0				FLAG	LINK
2-5	Reserved = 0							
6	Reserved = 0			Group Number = 0				
7	Additional CDB Length = 18h							
8-9	Service Action = 000Bh							
10	WRPROTECT			DPO	FUA	Rsvd=0	FUA_NV	Rsvd=0
11	Reserved = 0							
12-19	(MSB)	Logical Block Address						(LSB)
20-23	(MSB)	Expected Initial Logical Block Reference Tag						(LSB)
24-25	(MSB)	Expected Logical Block Application Tag						(LSB)
26-27	(MSB)	Logical Block Application Tag Mask						(LSB)
28-31	(MSB)	Transfer Length						(LSB)

The WRITE command requests that the drive write data transferred from the initiator to disk. Each logical block transferred includes user data and may include protection information, based on the WRPROTECT field and the drive format. Each logical block written includes user data and, if the drive is formatted with protection information enabled, protection information. If the drive is formatted with type 2 protection (PROT\_EN=1 and P\_TYPE=001b in the READ CAPACITY (16) parameter data), then this command will be processed normally. Any other protection types will result in Check Condition status to be returned with sense key of Illegal Request and additional sense code of Invalid Command Operation Code

The Expected Initial Logical Block Reference Tag field contains the value of the Logical Block Reference Tag field expected in the protection information of the first logical block accessed by the command.

If the ATO bit is set to one in Mode Page 0Ah, the Logical Block Application Tag Mask field contains a value that is a bit mask for enabling the checking of the Logical Block Application Tag field in the protection information for each logical block accessed by the command. A Logical Block Application Tag Mask bit set to one enables the checking of the corresponding bit of the Expected Logical Block Application Tag field with the corresponding bit of the Logical Block Application Tag field in the protection information.

If the ATO bit is set to zero, the Logical Block Application Tag Mask field and the Expected Logical Block Application Tag field are ignored.

## 18.55 WRITE AND VERIFY (10) - (2E)

Table 212: WRITE AND VERIFY (10) - (2E)

Byte	Bit							
	7	6	5	4	3	2	1	0
0	Command Code = 2Eh							
1	WRPROTECT			DPO	Reserved = 0		Byte Chk	Obsolete
2-5	(MSB) Logical Block Address (LSB)							
6	Reserved = 0							
7-8	(MSB) Transfer Length (LSB)							
9	VU = 0		Reserved = 0			FLAG	LINK	

WRITE AND VERIFY command requests that the drive writes the data transferred from the Initiator to the medium and then verify that the data is correctly written. If caching is enabled, an implied FUA (Force Unit Access) and an implied Synchronize Cache are performed before starting the operation. This insures that data from the disk, not the cache, is verified.

- See the WRITE (10) command description for the definition of the WRPROTECT field.
- **Transfer Length** is the number of contiguous blocks to transferred. If the transfer length is zero, the seek occurs, but no data is transferred. This condition is not considered an error.

If caching is enabled, the command performs an implied FUA and an implied Synchronize Cache before starting the operation. This insures that the medium, not the cache, is being verified.

- **ByteChk** bit set to zero indicates that the data is read back from the disk and verified using LDPC after the successful write operation. If an LDPC error is detected in the verify process, **Check Condition** status is returned with sense key set to *Medium Error*. ByteChk bit set to one indicates that byte-by-byte comparison is performed between data on the disk starting the block specified in LBA field and data transferred from the Initiator.

If the comparison is unsuccessful, the command is terminated with **Check Condition** status and the sense key is set to *Miscompare*.

- **DPO** (Disable Page Out) bit of one indicates that the data written by this command is to be assigned the lowest priority for being written into or retained by the cache. A DPO bit of one overrides any retention priority specified in the Mode Select Page 8 Caching parameters. A DPO bit of zero indicates the priority is determined by the retention priority.

The Initiator should set the DPO bit when the blocks written by this command are not likely to be read again in the near future.

## 18.56 WRITE AND VERIFY (12) - (AE)

Table 213: Write and Verify (12) - (AE)

Byte	Bit							
	7	6	5	4	3	2	1	0
0	Command Code = AEh							
1	WRPROTECT			DPO	Reserved = 0		ByteChk	Obsolete
2-5	(MSB) Logical Block Address (LSB)							
6-9	(MSB) Transfer Length (LSB)							
10	Reserved = 0							
11	VU = 0		Reserved = 0			FLAG	LINK	

The WRITE AND VERIFY command requests that the drive write the data transferred from the Initiator to the medium and then verify that the data is correctly written. See the WRITE AND VERIFY (10) description for the definitions of the fields in this command.

## 18.57 WRITE AND VERIFY (16) - (8E)

Table 214: Write and Verify (16) - (8E)

Byte	Bit							
	7	6	5	4	3	2	1	0
0	Command Code = 8Eh							
1	WRPROTECT			DPO	Reserved = 0		Byte Chk	Obsolete
2-9	(MSB) Logical Block Address (LSB)							
10-13	(MSB) Transfer Length (LSB)							
14	Reserved = 0							
15	VU = 0		Reserved = 0			FLAG	LINK	

The WRITE AND VERIFY command requests that the drive write the data transferred from the Initiator to the medium and then verify that the data is correctly written.

## 18.58 WRITE AND VERIFY (32) - (7F/0C)

Table 215: Write and Verify (32) - (7F/0C)

Byte	Bit							
	7	6	5	4	3	2	1	0
0	Command Code = 7Fh							
1	VU = 0		Reserved = 0				FLAG	LINK
2 - 5	Reserved = 0							
6	Reserved = 0			Group Number = 0				
7	Additional CDB Length = 18h							
8 - 9	Service Action = 000Ch							
10	WRPROTECT			DPO	Reserved = 0		ByteChk	Reserved=0
11	Reserved = 0							
12 - 19	Logical Block Address							
20 - 23	Expected Initial Logical Block Reference Tag							
24 - 25	Expected Logical Block Application							
26 - 27	Logical Block Application Tag Mask							
28 - 31	Transfer Length							

The WRITE AND VERIFY command requests that the drive write the data transferred from the initiator to disk and then verify that the data is correctly written.

If the drive is formatted with type 2 protection (PROT\_EN=1 and P\_TYPE=001b in the READ CAPACITY (16) parameter data), then this command will be processed normally. Any other protection types will result in Check Condition status to be returned with sense key of Illegal Request and additional sense code of Invalid Command Operation Code

The Expected Initial Logical Block Reference Tag field contains the value of the Logical Block Reference Tag field expected in the protection information of the first logical block accessed by the command.

If the ATO bit is set to one in Mode Page 0Ah, the Logical Block Application Tag Mask field contains a value that is a bit mask for enabling the checking of the Logical Block Application Tag field in the protection information for each logical block accessed by the command. A Logical Block Application Tag Mask bit set to one enables the checking of the corresponding bit of the Expected Logical Block Application Tag field with the corresponding bit of the Logical Block Application Tag field in the protection information.

If the ATO bit is set to zero, the Logical Block Application Tag Mask field and the Expected Logical Block Application Tag field are ignored.

## 18.59 WRITE BUFFER (3B)

Table 216: WRITE BUFFER (3B)

Byte	Bit							
	7	6	5	4	3	2	1	0
0	Command Code = 3Bh							
1	Reserved = 0			Mode				
2	Buffer ID							
3-5	Buffer Offset							
6-8	Parameter List Length							
9	VU = 0		Reserved = 0				FLAG	LINK

The WRITE BUFFER command is used in conjunction with the READ BUFFER command as a diagnostic function for testing the memory of the drive and the SCSI bus integrity. This command does not alter the medium of the drive. Additional modes are provided for downloading microcode and saving microcode.

This command will cause the entire cache to be emptied.

The function of this command and the meaning of fields within the command descriptor block depend on the contents of the mode field.

MODE	Description
00000	Write combined header and data
00010	Data
00100	Download Microcode
00101	Download Microcode and Save - single binary file
00111	Download Microcode and Save - multiple binary files
01010	Write Data to Echo Buffer
11010	Enable expander Communications Protocol
All Others	Not Supported

If any values other than shown above are specified, **Check Condition** status is returned with a sense key of *Illegal Request* and additional sense code of *Invalid Field in CDB*.

### 18.59.1 Combined Header And Data (Mode 00000b)

In this mode, the data to be transferred is preceded by a four-byte header.

**Buffer ID** must be zero. If another value is specified, no download function is performed and the command is terminated with **Check Condition** status. And the drive shall set the sense key to *Illegal Request* and additional sense code to *Illegal Field in CDB*.

**Buffer Offset** must be zero. If another value is specified, no download function is performed and the command is terminated with **Check Condition** status. And the drive shall set the sense key to *Illegal Request* and additional sense code to *Illegal Field in CDB*.

**Parameter List Length** specifies the number of bytes that shall be transferred during the DATA OUT phase. This number includes four bytes of header, so the data length to be stored in the drive buffer is transfer length minus four. If the length



exceeds the buffer size, the command is terminated with **Check Condition** status. And the drive shall set sense key to *Illegal Request* and additional sense code to *Illegal Field in CDB*. A Parameter List Length of less than four (size of header) indicates no data is transferred.

The 4-byte header consists of all reserved bytes.

**Table 217: Write Buffer Header**

Byte	Bit							
	7	6	5	4	3	2	1	0
0-3	Reserved = 0							

### 18.59.2 Write Data (Mode 00010b)

In this mode, the DATA OUT phase contains buffer data.

**Buffer ID** must be zero. If another value is specified, no download function is performed and the command is terminated with Check Condition status. And the drive shall set the sense key to *Illegal Request* and additional sense code to *Illegal Field In CDB*.

**Buffer Offset** specifies the offset of the memory space specified by the Buffer ID. The initiator should conform to the offset boundary requirements returned in the READ BUFFER descriptor. If the value exceeds the buffer specified, the command is terminated with **Check Condition** status. And the drive shall set the sense key to *Illegal Request* and additional sense code to *Illegal Field In CDB*.

**Parameter List Length** specifies the Parameter List Length. It must be

- less than the capacity of the buffer size after adding the Buffer Offset value and
- on a sector boundary

A Parameter List Length of zero indicates no data is to be transferred and command status is returned.

If an invalid value is specified, the command is terminated with **Check Condition** status. And the drive shall set the sense key to *Illegal Request* and additional sense code to *Illegal Field In CDB*.

### 18.59.3 Download Microcode (Mode 00100b)

**NOTE: It is not expected that a customer will ever issue this format of the command.**

In this mode, the microcode is transferred to the control memory space of the drive. When downloaded, the drive will operate with the newly downloaded code immediately until the next power cycle.

**Buffer ID** field is used to indicate which portion of the microcode image is being downloaded. The following Buffer IDs are supported by the Target:

- 00h: Main Microprocessor Code
- nnh: ID of Vendor Unique Reserved Area

Any unsupported value for the Buffer ID will cause the command to terminate with **Check Condition** status. And the drive shall set the sense key to *Illegal Request* and additional sense code to *Illegal Field In CDB*.

**Buffer Offset** must be zero. If an invalid value is specified, the command is terminated with **Check Condition** status. The drive shall set the sense key to *Illegal Request* and additional sense code to *Illegal Field in CDB*.

**Parameter List Length** must be the size of the data set to be downloaded. It may also be set to 0000h in which case no code is updated and command status is returned. If an invalid value is specified, the command is terminated with **Check Condition** status. And the drive shall set the sense key to *Illegal Request* and additional sense code to *Illegal Field In CDB*.

This process generates a unit attention condition for MICROCODE HAS BEEN CHANGED for all Initiators except the one

which sent the WRITE BUFFER command. Upon the completion of the WRITE BUFFER command the new microcode is immediately ready for operation.

**Note:** The Download Microcode mode described in this specification is to indicate that the drive will accept a command with this mode, though it is not expected that a user will ever issue such a command. To use the write buffer command with this mode, a special microcode version is required from development. If such a microcode is released from development, then it will include appropriate instructions on the function of new microcode and its effect on the drive operations after download.

### 18.59.4 Download Microcode and Save (Mode 00101b) -Single Binary File

In this mode the data is transferred to the drive to save into the System reserved area on the disk. This is for functional upgrade and configuration change reflecting the user's requirements and the manufacturer's reason or both, and it is stored in the media as a permanent copy. The newly downloaded code becomes effective after the drive issues and completes a self-initiated Power On Reset.

**Note:** It requires up to 30 seconds to update the microcode including the Flash ROM update.

**Note:** New code to be downloaded to the drive will be provided by development either by request of a customer for an additional function or as a result of a functional change by development. However please note that not all possible fixes or new functions can be applied to a drive in this manner and that there is a very high dependency on the level of ROM code contained within the drive. If an invalid code or a code not compatible with the ROM code is downloaded, the drive will usually reject this code and will continue normal operation. However there is a small possibility that an invalid code will be accepted. If this occurs, the unit usually becomes inoperable and will have to be returned to the manufacturer for recovery.

**Buffer ID** field is used to indicate which portion of the microcode image is being downloaded. To download microcode, the buffer ID should be set to 00h. Other values are reserved for HGST development purposes only.

### 18.59.5 Download Microcode and Save (Mode 00111b) - Multiple Binary Files

In this mode the target receives a segment of the binary microcode file. The Parameter List Length (segment length) of each segment shall be a multiple of 4K bytes. The total length of all segments received shall be equal to the total length of the binary microcode file. All segments must be sent in the proper sequential order.

If an invalid Parameter List Length is specified, **Check Condition** status is returned with sense key of Illegal Request and additional sense code of *Invalid Field in CDB*.

The first segment sent in this mode indicates, by default, the first segment of the binary microcode file. If a **Check Condition** status is returned in this mode, a **Buffer ID** == 00h in the subsequent Write Buffer command in this mode indicates the first segment of the binary microcode file. Otherwise the **Buffer ID** field is ignored.

The **Buffer Offset** field is ignored.

After all segments of the binary microcode file have been received, the drive behavior is the same as Download Microcode and Save (Mode 00101b) - Single Binary File.

### 18.59.6 Write Data to Echo Buffer (Mode 01010b)

In this mode the Target transfers data into the echo buffer. The echo buffer is assigned in the same manner by the Target as it would for a WRITE operation. Data will be sent aligned on 4-byte boundaries.

Upon successful completion of a WRITE BUFFER command the data will be preserved in the echo buffer unless there is an intervening command to any logical unit, in which case it may be changed.

## **18.59.7 Enable Expander Communications Protocol (Mode 11010b)**

In this mode the drive behavior is the same as Write Data to Echo Buffer (Mode 0101b).

## 18.60 WRITE LONG (10) (3F)

Table 218: WRITE LONG (3F)

Byte	Bit							
	7	6	5	4	3	2	1	0
0	Command Code = 3Fh							
1	COR_DIS	WR_UNCOR	PBLOCK =0	Reserved = 0				Obsolete
2-5	(MSB) Logical Block Address							(LSB)
6	Reserved = 0							
7-8	(MSB) Byte Transfer Length							(LSB)
9	VU = 0		Reserved = 0				FLAG	LINK

The WRITE LONG command requests the drive to write **one block** of data transferred from the Initiator.

The transfer data must include

- User Data
- 18 bytes of MEDC data

All WRITE LONG commands will behave as if the WR\_UNCOR bit was set with the exception of having the COR\_DIS bit set. COR\_DIS bit behavior will take precedence if both WR\_UNCOR and COR\_DIS bits are set

Parameters are

- **COR\_DIS** - correction disabled, bit 7 in byte 1. When this bit is set to one, the drive will mark the LBA as a pseudo unrecovered error with correction disabled. A subsequent read to this LBA would:
  - a) Perform no error recovery on the block;
  - perform no automatic reallocation of the affected logical blocks, including any automatic reallocation enabled by the Read-Write Error Recovery mode page;
  - c) Not consider errors on the affected logical blocks to be informational exception conditions as defined in the Information Exceptions Control mode page (see SPC-4);
  - d) not log errors on the affected logical blocks in the Error Counter log pages
  - e) On a read to the LBA, return check condition status with the sense key set to Medium Error and the additional sense code set to read error marked bad by client.
- **WR\_UNCOR** - write uncorrectable, bit 6 in byte 1. If the COR\_DIS bit is not set, the drive will behave in the following manor regardless of the state of this bit. The drive will create a pseudo unrecovered error with correction enabled. On following read commands to the LBA, the drive will:
  - a) use our normal recovery procedures (which will end in a hard error);
  - b) perform no automatic reallocation of the affected logical blocks, including any automatic reallocation enabled by the Read-Write Error Recovery mode page;

- c) consider errors on the affected logical blocks to be informational exception conditions as defined in the Information Exceptions Control mode page (see SPC-4);
- d) log errors on the affected logical blocks in the Error Counter log pages
- e) On a read to the LBA, return check condition status with the sense key set to Medium Error and the additional sense code set to read error marked bad by client.

The error state for LBA written with the COR\_DIS or WR\_UNCOR bits set, will remain in effect until the LBA is rewritten by a write, write same, format, write long without COR\_DIS set, reassign or write verify command.

- **Logical Block Address** field specifies the logical block at which the write operation shall occur.
- **Byte Transfer Length.** This field must specify the exact number of bytes of data available for transfer. If a non-zero byte transfer length does not match the available data length, the Target terminates the command with **Check Condition** status, then the sense key is set to *Illegal Request*, and an additional sense code is set to *Invalid Field in CDB*. The valid and ILI bits are set to one and the information field is set to the difference of the requested length minus the actual length in bytes. Negative values are indicated by two's complement notation.

## 18.61 WRITE LONG (16) (9F)

Table 219: WRITE LONG (9F)

Byte	Bit							
	7	6	5	4	3	2	1	0
0	Command Code = 9Fh							
1	COR_DIS	WR_UNCOR	PBLOCK =0	Service Action (11h)				
2-9	(MSB) Logical Block Address (LSB)							
10-11	Reserved = 0							
12-13	(MSB) Byte Transfer Length (LSB)							
14	Reserved = 0							
15	VU = 0		Reserved = 0				FLAG	LINK

Refer to Write Long (10) for field definitions.

## 18.62 WRITE SAME (10) - (41)

Table 220: WRITE SAME (41)

Byte	Bit							
	7	6	5	4	3	2	1	0
0	Command Code = 41h							
1	WRPROTECT			Reserved = 0		PBDA TA=0	LBDA TA=0	Obso- lete
2-5	(MSB) Logical Block Address (LSB)							
6	Reserved = 0							
7-8	(MSB) Number of Blocks (LSB)							
9	VU = 0		Reserved = 0			FLAG	LINK	

The WRITE SAME command instructs the Target to write a single block of data transferred to the Target from the Initiator to a number of sequential logical blocks. This command is useful for writing large data areas without sending all of the data over the SCSI bus.

- See the WRITE(10) command description for the definition of the WRPROTECT field.
- **Logical Block Address** specifies the address at which the write begins. The Number of Blocks specifies the number of contiguous blocks to be written. If the number is zero, all of the remaining blocks on the specified Logical Unit are written.
- **Number of Blocks** specifies the number of contiguous blocks to be written. If the number is zero, all of the remaining blocks on the specified logical unit are written.
- **RelAdr** (Relative Block Address) is not supported and must be set to be zero.

The data for this command is not retained in the cache.

## 18.63 WRITE SAME (16) - (93)

Table 221: Write Same (16) - (93)

Byte	Bit							
	7	6	5	4	3	2	1	0
0	Command Code = 93h							
1	WRPROTECT		Reserved = 0		PBDATA =0	LBDATA =0	Obsolete	
2-9	(MSB) Logical Block Address (LSB)							
10-13	(MSB) Number of Blocks (LSB)							
14	Reserved = 0							
15	VU = 0		Reserved = 0			FLAG	LINK	

The Write Same command instructs the Target to write a single block of data transferred to the Target from the Initiator to a number of sequential logical blocks. This command is useful for writing large data areas without sending all of the data over the SCSI bus. See the WRITE(10) command description for the definition of the WRPROTECT field.



## 18.64 WRITE SAME (32) - (7F/0D)

Table 222: Write Same (32) - (7F/0D)

Byte	Bit							
	7	6	5	4	3	2	1	0
0	Command Code = 7Fh							
1	VU = 0		Reserved = 0				FLAG	LINK
2-5	Reserved = 0							
6	Reserved = 0			Group Number = 0				
7	Additional CDB Length = 18h							
8 - 9	Service Action = 000Dh							
10	WRPROTECT			Reserved = 0		PBDATA =0	LBDATA =0	Reserved =0
11	Reserved = 0							
12 - 19	(MSB) Logical Block Address (LSB)							
20 - 23	(MSB) Expected Initial Logical Block Reference Tag (LSB)							
24 - 25	(MSB) Expected Logical Block Application Tag (LSB)							
26 - 27	(MSB) Logical Block Application Tag Mask (LSB)							
28 - 31	(MSB) Number of Blocks (LSB)							

The WRITE SAME command requests that the drive write a single block of data transferred from the initiator to disk for a number of sequential logical blocks. This command is useful for writing large data areas with the same data, without sending all of the data over the interface. Each logical block transferred includes user data and may include protection information, based on the WRPROTECT field and the drive format. Each logical block written includes user data and, if the drive is formatted with protection information enabled, protection information.

If the drive is formatted with type 2 protection (PROT\_EN=1 and P\_TYPE=001b in the READ CAPACITY (16) parameter data), then this command will be processed normally. Any other protection types will result in Check Condition status to be returned with sense key of Illegal Request and additional sense code of Invalid Command Operation Code

The Expected Initial Logical Block Reference Tag field contains the value of the Logical Block Reference Tag field expected in the protection information of the first logical block accessed by the command.

If the ATO bit is set to one in Mode Page 0Ah, the Logical Block Application Tag Mask field contains a value that is a bit mask for enabling the checking of the Logical Block Application Tag field in the protection information for each logical block accessed by the command. A Logical Block Application Tag Mask bit set to one enables the checking of the corresponding bit of the Expected Logical Block Application Tag field with the corresponding bit of the Logical Block Application Tag field in the protection information.

If the ATO bit is set to zero, the Logical Block Application Tag Mask field and the Expected Logical Block Application Tag field are ignored.

## 19.0 SCSI Status Byte

Upon the completion of a command a status byte is sent to the initiator. Additional sense information may also be available depending on the contents of the status byte. The following section describes the possible values for the status byte and sense data. All Reserved fields are set to zero.

**Table 223: SCSI Status Byte. Format of the SCSI STATUS byte.**

Bit							
7	6	5	4	3	2	1	0
Reserved = 0		Status Code					RSVD

### STATUS BYTE Description

<b>00h</b>	<b>GOOD</b> The command has been successfully completed.
<b>02h</b>	<b>CHECK CONDITION</b> An error, exception, or abnormal condition has been detected. The sense data is set by the drive. The REQUEST SENSE command should be issued to determine the nature of the condition.
<b>04h</b>	<b>CONDITION MET</b> This status is returned when an unlinked PRE-FETCH command has been successfully completed.
<b>08h</b>	<b>BUSY</b> This condition is returned when disconnect privilege is not granted while the drive is BUSY processing the other command for the other initiator. The normal initiator recovery action is to issue the command at a later time or to reissue the command and grant the disconnect privilege.
<b>10h</b>	<b>INTERMEDIATE</b> Not supported.
<b>14h</b>	<b>INTERMEDIATE CONDITION MET</b> Not supported.
<b>18h</b>	<b>RESERVATION CONFLICT</b> This status is returned whenever an SCSI device attempts to access the drive, but it has been reserved by another initiator.
<b>28h</b>	<b>QUEUE FULL</b> This status indicates that the target's command queue is full. If a tagged command queuing feature is enabled and there is no room on the command queue, this status is returned when the initiator sends a command. For this status, sense data are not valid.



## 20.0 Additional information

This chapter provides additional information or descriptions of various functions, features, or operating models supported by the Target that are not fully described in previous chapters.

### 20.1 SCSI Protocol

There are various operating conditions that prevent the Target from executing a SCSI command. This section describes each of these operating conditions and their relative priority.

#### 20.1.1 Priority of SCSI Status Byte Reporting

After establishing the I\_T\_L nexus or I\_T\_L\_Q nexus the Target must first determine whether command execution is allowed. Execution is deferred until a later time if the command must be added to the command queue. Execution may also be prevented by an internal Target condition that requires the reporting of a Check Condition, Queue Full, Busy, or Reservation Conflict Status. There are several different internal conditions to be active at the same time. The order in which the Target checks for each of these conditions determines their priority (highest priority first) as follows:

1. Check Condition status for invalid Logical Unit Number. (See Section 20.1.2, “Invalid LUN Processing” on page 269)
2. Check Condition status for Incorrect Initiator Connection (See Section 20.1.3, “Overlapped Commands” on page 270)
3. Check Condition status for Unit Attention Condition (See Section 20.1.5, “Unit Attention Condition” on page 271)
4. Busy Status or Queue Full Status (See 20.1.4, “Command Processing During Execution of Active I/O Process” on page 270)
5. Check Condition status for Deferred Error Condition (See Section 20.1.8, “Deferred Error Condition” on page 273)
6. Check Condition status during Startup and Format operations (See Section “20.1.6, “Command Processing During Startup and Format Operations” on page 273)
7. Reservation Conflict status (See Section 20.1.10, “Command Processing while Reserved” on page 281)
8. Check Condition status for invalid command opcode
9. Check Condition status for invalid command descriptor block

The highest priority internal condition that prevents command execution is reported by the Target provided there is no bus error.

For all Check Conditions Sense data is built by the target provided a valid LUN address is known. Sense data is cleared by the Target upon receipt of any subsequent command to the LUN from the initiator receiving the Check Condition.

#### 20.1.2 Invalid LUN Processing

Any value other than zero is invalid.

The target's response to an invalid LUN varies with the command, as follows:

**Inquiry:** Execute the command, return the INQUIRY data that indicates unknown device type (byte 0 = 7Fh), and return GOOD status. All other bytes are valid (see 18.5, “INQUIRY (12)” on page 78).

**Request Sense:** Execute the command, return the sense data with the Sense Key set to Illegal Request and the Additional Sense Code and Additional Sense Code Qualifier set to LOGICAL UNIT NOT SUPPORTED, and return GOOD status (see also 18.36, “REQUEST SENSE (03)” on page 219).

**All Others:** Do not execute the command and return CHECK CONDITION status, along with the auto-sense data with the Sense Key set to Illegal Request and the Additional Sense Code and Additional Sense Code Qualifier set to LOGICAL UNIT NOT SUPPORTED.

In all cases, the target's response to the command for an invalid LUN does not affect the current execution of a command on the valid LUN for this initiator or any other initiator.

### 20.1.3 Overlapped Commands

The the drive does not perform any overlapped command checking.

### 20.1.4 Command Processing During Execution of Active I/O Process

When the target is not executing any I/O processes, a new I/O process is permitted to execute (unless execution is prevented by another internal target condition listed in 20.1.1, “Priority of SCSI Status Byte Reporting” on page 269).

If an active I/O process exists when the target receives a new command, then the target determines if:

- the command is permitted to execute
- the command is added to the queue
- Queue Full status is to be returned
- Busy status is to be returned

If an active I/O process exists when the target receives a new command, then the target determines how the new command should be handled based on the following rules:

- Check Condition status is returned with sense key set to Logical Unit Not Ready if:
  - the startup operation or a format operation is active. See 20.1.4, “Command Processing During Execution of Active I/O Process” on page 270 for the exact conditions which cause this response.

**Note:** If a Unit Attention is pending when this condition exists, the sense key is set to Unit Attention rather than Logical Unit Not Ready since Unit Attention has a higher reporting priority (see 20.1.1, “Priority of SCSI Status Byte Reporting” on page 269).

- The command is permitted to execute if:
  - the command is a priority command (see 20.5, “Concurrent I/O Process” on page 282).
- the conditions to execute concurrently are met (see 20.5, “Concurrent I/O Process” on page 282).
- The command is added to the queue if:
  - any I/O process already exists at the target, and
  - this is not an incorrect initiator connection.
- Queue Full status is returned if:
  - the command would otherwise be added to the queue (according to the rules described above), but all slots in the queue are full, or
  - the command would otherwise be added to the queue (according to the rules described above), but all of the available queue slots not reserved for use by another initiator are full, or
  - a Format Unit command was previously queued but has not yet begun execution, or
  - the target is in a Degraded Mode (see 20.1.9, “Degraded Mode” on page 274) and a Start Unit command was previously queued but has not yet begun execution.
- Busy status is never returned on SCSI or FCAL. BUSY status is returned on SAS if more than 64 unique Initiators send frames to the drive since the last POR. In that case, BUSY status is only returned for Initiators above and beyond the first 64.

## 20.1.5 Unit Attention Condition

The target generates a unit attention condition when one of the following occurs:

- The target has been reset

This includes a power-on reset or a reset caused by a LUN Reset Task Management function or Hard Reset sequence. In all of these cases, a unit attention condition is generated for each initiator.

- MODE SELECT command has been executed

In this case, a unit attention condition is generated for all initiators except the one that issued the MODE SELECT command. The Additional Sense Code and Additional Sense Code Qualifier reported is MODE PARAMETERS CHANGED. The unit attention condition is generated if any of the current page parameters are set by the MODE SELECT command. The target does not check to see that the old parameters are different from the new parameters. For example: If the initiator issues a MODE SENSE command with a page code to report the current values followed by a MODE SELECT command with the same parameter list, a unit attention condition is generated despite the fact that the current parameters were not changed from their previous value. However, if the target detects an illegal parameter or error condition prior to modifying the current parameters, a unit attention condition is not generated since the parameters were not set. The unit attention condition is also not generated if the MODE SELECT command parameter list does not include any pages and only the header or header/block descriptor is present.

- FORMAT UNIT command has been executed

In this case, a unit attention condition is generated for all initiators except the one that issued the FORMAT UNIT command. The Additional Sense Code and Additional Sense Code Qualifier reported is NOT READY TO READY TRANSITION, (MEDIUM MAY HAVE CHANGED). This indicates that the block descriptor parameters from the last MODE SELECT command have been used and are now considered current values.

- WRITE BUFFER command to download microcode has been executed

In this case, a unit attention condition is generated for all initiators except the one that issued the WRITE BUFFER command. The Additional Sense Code and Additional Sense Code Qualifier reported is MICROCODE HAS BEEN CHANGED.

- Commands Cleared by another initiator

This unit attention condition is generated after an initiator sends a Clear Task Set Task Management function. The unit attention condition is generated for all other initiators with I/O processes that were either active or queued for the logical unit. The Additional Sense Code and Additional Sense Code Qualifier reported is COMMANDS CLEARED BY ANOTHER INITIATOR.

- LOG SELECT command with PCR bit has cleared parameters.

In this case, a unit attention condition is generated for all initiators except the one that issued the LOG SELECT command. The additional sense code and additional sense code qualifier reported is Log Select Parameters Changed.

- The registration or reservation made by a Persistent Reserve Out command was cleared by another initiator.

In this case, a unit attention condition is generated for the initiator that held the cleared registration or reservation.

- A Predictive Failure Analysis threshold has been reached and the Method of Reporting field of mode page 1Ch is 2h.

The unit attention condition persists for each initiator until that initiator clears the condition from the logical unit as described below. Several commands are handled as special cases during a unit attention condition. These cases are also discussed below.

If the target receives a command from an initiator before reporting a CHECK CONDITION status for a pending unit attention condition for that initiator, the target's response varies with the command as follows:

- Inquiry**            Execute the command, return GOOD status, and preserve the unit attention condition.
- Report Luns**       Same as above
- Request Sense**    Execute the command, return any pending sense data, return GOOD status, and preserve the unit attention condition. If there is not any pending sense data, the sense data associated with the highest priority unit attention condition is returned and the highest priority unit attention condition is cleared for this initiator.
- All Others**        Do not execute the command, return a CHECK CONDITION status, clear the highest priority unit attention condition for this initiator and return the associated sense data.

More than one unit attention condition may be generated for an initiator before that initiator clears the unit attention condition.



## 20.1.6 Command Processing During Startup and Format Operations

If the Target receives a command from an Initiator while the Target is executing a startup or format operation, the response of the Target varies with the command as follows:

<b>INQUIRY</b>	The drive sends inquiry data and returns appropriate status.
<b>REQUEST SENSE</b>	Executes the command, returns a Sense key of NOT READY and an Additional Sense Code of LOGICAL UNIT NOT READY and returns GOOD STATUS.  The Additional Sense Code Qualifier that is returned depends on type of I/O processes that are active:  For the START/UNIT STOP and the Auto-start operation, the qualifier returned is LOGICAL UNIT IS IN PROCESS OF BECOMING READY. For the FORMAT UNIT command, the qualifier returned is LOGICAL UNIT NOT READY, FORMAT IN PROGRESS, and the Sense key specific bytes are set to return the progress indication.
<b>REPORT LUNS</b>	The drive sends REPORT LUNS data and appropriate status.
<b>ALL OTHER</b>	The drive terminates the command with CHECK CONDITION status. The Sense data generated is described in Request Sense above.

## 20.1.7 Internal Error Condition

The Target generates an Internal Error condition for all Initiators when an internally initiated operation ends with an unrecoverable error, that is, the startup sequence for Auto Start enabled terminates after the SCSI bus has been enabled and prior to completion of the bring-up sequence.

An Internal Error condition causes Sense data to be generated and saved for all Initiators. The Error Code field of the Sense is set for a Current Error (70h or 72h) and the Sense Key is set to HARDWARE ERROR. Recovered errors are not reported.

The Internal Error condition persists for each Initiator until that Initiator clears the condition from the logical unit as described below. Several commands are handled as special cases during an Internal Error condition. These cases are also discussed.

If the Target receives a command from an Initiator while an Internal Error condition exists for that Initiator, the response of the Target varies with the command as follows:

<b>INQUIRY</b>	The drive executes the command with GOOD status and does not clear the Internal Error condition.
<b>REQUEST SENSE</b>	The drive executes the command, returns the sense data generated by the Internal Error condition, returns Good Status, and clears the Internal Error condition for that Initiator.
<b>ALL OTHER</b>	The drive terminates the command with a CHECK CONDITION status and clears the Internal Error condition.

## 20.1.8 Deferred Error Condition

Error code (71h or 73h) of sense data indicates that the Check Condition status returned is the result of an error or exception condition that occurred during execution of a previous command for which Good status has already been returned.

The drive creates an Deferred Error condition when

- Execution of a Format Unit command with the immediate bit of one ends with an error.
- Execution of a Write command with WCE (Write Cache Enable) bit of one ends with an error.

## 20.1.9 Degraded Mode

There are certain errors or conditions which may impair the ability of the drive to function normally. Rather than fail hard the drive is designed to be as responsive as possible. Also, in most cases, some action on the part of the initiator may be used to restore normal operation. This mode of limited operation is called Degraded Mode.

There are 3 conditions in the Degraded Mode:

- Spindle Motor Degrade which is caused by one of the following conditions:
  - Spindle Motor was started (by POR or Unit Start command) and the Target is under Self Configuration.
  - Spindle Motor Failed to start.
  - Spindle Motor was stopped by Unit Stop command after the Target successfully completed the Self Configuration.
- Self Configuration Failure Degraded which is caused by one of the following conditions:
  - RAM Code, Configuration Sector Read Failure
  - RAM Code, Configuration Sector Revision Mismatch
- Format Command Failure Degraded. This condition is caused when Format Unit command failed or was interrupted abnormally (Mode Page 0, byte 5, bit 4 FDD controls Format Degraded mode)

### 20.1.9.1 Response to SCSI Command in Degraded Mode - Disable Auto Start

The tables on the following pages show the degraded mode status with acceptable commands and additional sense codes

**Table 224: Spindle Motor Degraded Mode - Disable Auto Start**

Command (w/Option)	Response
<b>Request Sense</b>	Executed. The Target may return Sense Key 02h (Not Ready) ASC/ASCQ 0402h (Initialize Command Required)
<b>Inquiry (EVPD=0)</b>	Executed
<b>Inquiry (EVPD=1)</b>	Executed and Check Condition is returned with Sense Key 05h (Illegal Request) ASC/ASCQ 2400h (Invalid Field in CDB)
<b>Test Unit Ready</b>	Executed and Check Condition is returned with Sense Key 02h (Not Ready) ASC/ASCQ 0402h (Initialize Command Required)
<b>Start Stop Unit (Start)</b>	<p>Executed</p> <ul style="list-style-type: none"> <li>- Success: Good Status is returned. Motor Degraded Mode is cleared</li> <li>- Spindle Motor Start Failure: Check Condition with Sense Key 02h (Not Ready) ASC/ASCQ 0400h (Start Spindle Motor Fail)</li> <li>- Self Configuration Failure: Check Condition with Sense Key 02h (Not Ready) ASC/ASCQ 4080h (Diag Fail- Bring up Fail)</li> </ul> <p>Sense Key 02h (Not Ready) ASC/ASCQ 4085h (Diag Fail-RAM Code NOT load)</p>
<b>Start Stop Unit (Stop)</b>	Executed. Good Status is returned. Motor Degraded Mode is NOT cleared
<b>Other Commands</b>	Not Executed. Check Condition Status is returned with Sense Key 02h (Not Ready) ASC/ASCQ 0402h (Initialize Command Required)

## 20.1.9.2 Response to SCSI Command in Degraded Mode - Auto Start Delay/ Spinning Up

**Table 225: Spindle Motor Degraded Mode - Auto Start Delay/Spinning Up**

<b>Command (w/Option)</b>	<b>Response</b>
<b>Request Sense</b>	Executed. The Target may return Sense Key 02h (Not Ready) ASC/ASCQ 0401h (In Process of Becoming Ready)
<b>Inquiry (EVPD=0)</b>	Executed
<b>Inquiry (EVPD=1)</b>	Executed and Check Condition is returned with Sense Key 05h (Illegal Request) ASC/ASCQ 2400h (Invalid Field in CDB)
<b>Test Unit Ready</b>	Executed and Check Condition is returned with Sense Key 02h (Not Ready) ASC/ASCQ 0401h (In Process of Becoming Ready)
<b>Start Stop Unit (Start)</b>	<p>Executed</p> <ul style="list-style-type: none"> <li>- Success: Good Status is returned. Motor Degraded Mode is cleared</li> <li>- Spindle Motor Start Failure: Check Condition with Sense Key 02h (Not Ready) ASC/ASCQ 0400h (Start Spindle Motor Fail)</li> <li>- Self Configuration Failure: Check Condition with Sense Key 02h (Not Ready) ASC/ASCQ 4080h (Diag Fail- Bring up Fail)</li> </ul> <p>Sense Key 02h (Not Ready) ASC/ASCQ 4085h (Diag Fail-RAM Code NOT load)</p>
<b>Other Commands</b>	Not Executed. Check Condition Status is returned with Sense Key 02h (Not Ready) ASC/ASCQ 0401h (In Process of Becoming Ready)

### 20.1.9.3 Response to SCSI Command in Degraded Mode - Spindle Start Failure

**Table 226: Spindle Motor Degraded Mode - Spindle Start Failure**

Command (w/Option)	Response
<b>Request Sense</b>	Executed. The Target may return Sense Key 02h (Not Ready) ASC/ASCQ 0400h (Start Spindle Motor Fail)
<b>Inquiry (EVPD=0)</b>	Executed
<b>Inquiry (EVPD=1)</b>	Executed and Check Condition is returned with Sense Key 05h (Illegal Request) ASC/ASCQ 2400h (Invalid Field in CDB)
<b>Test Unit Ready</b>	Executed and Check Condition is returned with Sense Key 02h (Not Ready) ASC/ASCQ 0400h (Start Spindle Motor Fail)
<b>Start Stop Unit (Start)</b>	<p>Executed</p> <ul style="list-style-type: none"> <li>- Success: Good Status is returned. Motor Degraded Mode is cleared</li> <li>- Spindle Motor Start Failure: Check Condition with Sense Key 02h (Not Ready) ASC/ASCQ 0400h (Start Spindle Motor Fail)</li> <li>- Self Configuration Failure: Check Condition with Sense Key 02h (Not Ready) ASC/ASCQ 4080h (Diag Fail- Bring up Fail)</li> </ul> <p>Sense Key 02h (Not Ready) ASC/ASCQ 4085h (Diag Fail-RAM Code NOT load)</p>
<b>Start Stop Unit (Stop)</b>	Executed. Good Status is returned. Motor Degraded Mode is NOT cleared
<b>Other Commands</b>	Not Executed. Check Condition Status is returned with Sense Key 02h (Not Ready) ASC/ASCQ 0400h (Start Spindle Motor Fail)

## 20.1.9.4 Response to SCSI Command in Degraded Mode - Spindle Stopped by Unit Stop Command

**Table 227: Spindle Motor Degraded Mode - Spindle Stopped by Command**

<b>Command (w/Option)</b>	<b>Response</b>
<b>Request Sense</b>	Executed. The Target may return Sense Key 02h (Not Ready) ASC/ASCQ 0402h (Initialize Command Required)
<b>Inquiry (EVPD=0)</b>	Executed
<b>Inquiry (EVPD=1)</b>	Executed
<b>Test Unit Ready</b>	Executed and Check Condition is returned with Sense Key 02h (Not Ready) ASC/ASCQ 0402h (Initialize Command Required)
<b>Start Stop Unit (Start)</b>	<p>Executed</p> <ul style="list-style-type: none"> <li>- Success: Good Status is returned. Motor Degraded Mode is cleared</li> <li>- Spindle Motor Start Failure: Check Condition with Sense Key 02h (Not Ready) ASC/ASCQ 0400h (Start Spindle Motor Fail)</li> <li>- Self Configuration Failure: Check Condition with Sense Key 02h (Not Ready) ASC/ASCQ 4080h (Diag Fail- Bring up Fail)</li> </ul> <p>Sense Key 02h (Not Ready) ASC/ASCQ 4085h (Diag Fail-RAM code NOT load)</p>
<b>Start Stop Unit (Stop)</b>	Executed. Good Status is returned. Motor Degraded Mode is NOT cleared
<b>Other Commands</b>	Not Executed. Check Condition Status is returned with Sense Key 02h (Not Ready) ASC/ASCQ 0402h (Initialize Command Required)

## 20.1.9.5 Self Configuration Failure Degraded Mode

Table 228: Self Configuration Failure Degraded Mode

Command (w/Option)	Response
<b>Request Sense</b>	Executed. The Target may return Sense Key 02h (Not Ready) ASC/ASCQ 4080h (Diag Fail- Bring up Fail) Sense Key 02h (Not Ready) ASC/ASCQ 4085h (Diag Fail-RAM code NOT load)
<b>Inquiry (EVPD=0)</b>	Executed
<b>Inquiry (EVPD=1)</b>	Executed and Check Condition is returned with Sense Key 05h (Illegal Request) ASC/ASCQ 2400h (Invalid Field in CDB)
<b>Test Unit Ready</b>	Executed and Check Condition is returned with Sense Key 02h (Not Ready) ASC/ASCQ 4080h (Diag Fail- Bring up Fail) Sense Key 02h (Not Ready) ASC/ASCQ 4085h (Diag Fail-RAM code NOT load)
<b>Start Stop Unit (Start)</b>	Executed - Success: Good Status is returned. Motor Degraded Mode is cleared - Spindle Motor Start Failure: Check Condition with Sense Key 02h (Not Ready) ASC/ASCQ 0400h (Start Spindle Motor Fail) - Self Configuration Failure: Check Condition with Sense Key 02h (Not Ready) ASC/ASCQ 4080h (Diag Fail- Bring up Fail) Sense Key 02h (Not Ready) ASC/ASCQ 4085h (Diag Fail-RAM code NOT load)
<b>Write Buffer (Download and Save)</b>	Executed. - Success: Good Status is returned. Motor Degraded Mode is cleared - Self Configuration Failure: Check Condition with Sense Key 02h (Not Ready) ASC/ASCQ 4080h (Diag Fail- Bring up Fail) Sense Key 02h (Not Ready) ASC/ASCQ 4085h (Diag Fail-RAM code NOT load)
<b>Other Commands</b>	Not Executed. Check Condition Status is returned with Sense Key 02h (Not Ready) ASC/ASCQ 4080h (Diag Fail- Bring up Fail) Sense Key 02h (Not Ready) ASC/ASCQ 4085h (Diag Fail-RAM code NOT load)

### 20.1.9.6 Format Command Failure Degraded Mode

**Table 229: Format Command Failure Degraded Mode**

Command (w/Option)	Response
<b>Request Sense</b>	Executed. The Target may return Sense Key 02h (Not Ready) ASC/ASCQ 3100h (Format Corrupted) Sense Key 03h (Medium Error) ASC/ASCQ 3100h (Format Corrupted)
<b>Inquiry (EVPD=0)</b>	Executed
<b>Inquiry (EVPD=1)</b>	Executed
<b>Test Unit Ready</b>	Executed and Check Condition is returned with Sense Key 02h (Not Ready) ASC/ASCQ 3100h (Format Corrupted)
<b>Format Unit</b>	Executed - Success: Good Status is returned. Format Degraded Mode is cleared - Failure: Check Condition Status is returned and Format Degraded Mode is NOT cleared.
<b>Other Commands</b>	Not Executed. Check Condition Status is returned with Sense Key 03h (Medium Error) ASC/ASCQ 3100h (Format Corrupted)

**Note:** Mode Page 0 byte 5 bit 4 (FDD) = 0



## 20.1.10 Command Processing while Reserved

A logical unit is reserved after successful execution of the Reserve command. Each time a Reserve command is executed successfully, the Target records the SCSI ID of the Initiator that made the reservation and the SCSI ID of the Initiator that is to receive the reservation. This information is needed to determine whether subsequent commands should be permitted or if the Reservation Conflict Status should be reported. The Initiator that made the reservation is the Initiator that issued the Reserve command. The Initiator to receive the reservation may be either the same or a different Initiator (third-party reservation).

If the logical unit is reserved when a new command is received, the Target examines the command opcode and the SCSI ID of the issuing Initiator to determine whether a Reservation Conflict Status should be returned based on the following rules:

If the issuing Initiator is the one that made the reservation and also the one to receive the reservation, then all commands are permitted.

If the issuing Initiator is neither the one that made the reservation nor the one to receive the reservation, then

- A Request Sense or Inquiry command is permitted.
- A Release command is permitted but is ignored.
- Any other command results in a Reservation Conflict Status.

If the issuing Initiator is the one that made the reservation but is not the one to receive the reservation, then

- An Inquiry, Request Sense, Reserve, or Release command is permitted.
- Any other command results in a Reservation Conflict Status.

If the issuing Initiator is not the one that made the reservation but is the one to receive the reservation, then

- A Reserve command results in a Reservation Conflict Status.
- A Release command is permitted but is ignored.
- Any other command is permitted.

If a Reservation Conflict Status is not reported and the command is permitted, then the Target checks the next highest priority internal condition to determine whether execution is allowed. See Section 20.1.1, “Priority of SCSI Status Byte Reporting” on page 269.

## 20.2 Priority Commands

Certain SCSI commands always execute without returning a Busy Status or Reservation Conflict Status in response to the command. These commands are

- Inquiry
- Request Sense
- Report LUNs
- Test Unit Ready

These commands are executed prior to attempting to complete the execution of any other pending command in the queue. These commands are never queued.

## 20.3 Command Queuing

When the initiator specifies that the drive shall disable command queuing, the initiator must send only untagged commands. When the initiator specifies that the target shall enable command queuing, the initiator may send either tagged or untagged command, but shall not use both at the same time.

The following commands are never queued.

- Priority Commands (i.e.: Request Sense and Inquiry)
- Commands for an invalid LUN.

### 20.3.1 Queue Depth

Any initiator can queue at least one command at any time irrespective of the actions of any other initiators in the system. A single initiator may queue up to 128 commands, if no other initiator has more than one command in the queue, although at times this maximum may be reduced as the drive can reserve command blocks for internal use.

### 20.3.2 Queue Full Status

The drive will respond with QUEUE FULL status to a SCSI command when all queue slots are utilized. The SCSI command is not placed in the command queue under this condition.

### 20.3.3 Termination of I/O Processes

Normal termination of I/O processes occurs when the target returns SCSI status. I/O processes may also be terminated by the following:

- An ABORT TASK terminates the specified I/O process from the issuing initiator
- An ABORT TASK SET terminates all I/O processes from the issuing initiator
- A CLEAR TASK SET, TARGET RESET or reset terminates all I/O processes from all initiators

## 20.4 Command Reordering

Command reordering is supported when enabled by the Queue Algorithm Modifier in mode page 0A (see 18.10.9, “Mode Page 0A (Control Mode Page Parameters)” on page 151).

## 20.5 Concurrent I/O Process

Concurrent command are always allowed to execute concurrently with non-priority commands. A second priority command received while a priority command is being executed is put at the head of the command queue.

- WRITE commands when another WRITE command is an active I/O process
- READ commands when another READ command is an active I/O process

When a concurrent command ends in CHECK CONDITION status, the QErr bit on the Mode Page 0Ah will determine how other active I/O processes from the same initiator for that drive will be handled.

## 20.6 Write Cache

If the WCE (Write cache enable) bit is 1, the drive returns Good Status and closes the connection immediately after receiving the data of the last sector before actually writing the data onto the media.

If the drive detects an error after it returns a Good Status, the drive sets a Deferred Error (Error Code of sense data = 71h) and a following command will be returned with Check Condition and the Contingent allegiance condition is established. Under the Contingent allegiance condition all queued processes including commands from other initiators are suspended.

## 20.7 Automatic Rewrite/Reallocate

The target supports Auto and Recommended Reallocate for READ, WRITE, WRITE VERIFY, and VERIFY.

Automatic and Recommend Reallocate operate from within the read/write command. When an automatic reallocation occurs, the read or write command takes longer to complete.

This operation is sometimes referred to as auto-reassignment due to its similarity to the operation performed by the reassign command.

Following is a description of the target behavior for each setting of ARRE. ARRE setting affects all data errors. (No Sector Found, Data Sync Byte Errors and Data LDPC Errors.)

**ARRE=1:** An error site determined to need rewriting or reallocation during a read is automatically rewritten or reallocated at the conclusion of the read and prior to the sending of the status. The site will be automatically rewritten or reallocated only if the data has been successfully read.

**ARRE=0:** An error site determined to need rewriting or reassignment during a read is recommended for rewriting or reassignment at the conclusion of the read.

The setting of the ARRE bit is checked and the target will automatically rewrite/reallocate or recommend rewrite/reassign for the following commands.

- Read
- Write

For all other commands the ARRE setting is ignored and the target will not automatically rewrite/ reallocate or recommend rewrite/reassign.

Following is a description of the target behavior for each setting of AWRE. AWRE setting effects only No Sector Found Errors on writes.

**AWRE=1:** An error site determined to need reassignment during a write is automatically reallocated at the conclusion of the write and prior to sending the status. The site will be automatically reallocated only if the write recovery succeeded at the conclusion of the write.

**AWRE=0:** An error site determined to need reassignment during a write is recommended for reassignment at the conclusion of the write.

The setting of the AWRE bit is checked and the target will automatically reallocate or recommend reassign for the following commands.

- Write(6)
- Write(10)
- Write portion of Write and Verify

For all other commands the AWRE setting is ignored and the target will not automatically reallocate or recommend reassign.

Auto/Recommend Reallocate information is communicated via the sense data returned following a command during which a site was determined to need rewriting or reassignment. The LBA returned in the sense data is the LBA that was determined to need rewriting or reassignment.

The sense data combinations with auto/recommend rewrite/reallocate are listed below.

**Table 230: Sense data combinations with auto/recommend rewrite/reallocate**

Key	Code	Qual	Description
1	17	01	Recovered Data with retries
1	17	06	Recovered Data without LDPC - Auto Reallocated
1	17	07	Recovered Data without LDPC - Recommend Reassign
1	17	09	Recovered Data without LDPC - Data Rewritten
1	18	00	Recovered Data with LDPC
1	18	02	Recovered Data with LDPC - Auto Reallocated
1	18	05	Recovered Data with LDPC - Recommend Reassign
1	18	07	Recovered Data with LDPC - Data Rewritten

## 20.8 Segmented Caching

### 20.8.1 Overview

Segmented Caching divides the data buffer into several smaller buffers. Each buffer is used as Read/ Write/Read-Ahead buffer.

### 20.8.2 Read Ahead

The Read Ahead function consists of reading data that the Initiator has not yet requested to the drive buffer. This function is intended to improve performance for an initiator that frequently accesses sequential data with successive SCSI read commands. The Read Ahead function works when RCD (the read cache disable) bit of read cache page (page 08h) is set to zero.

The drive initiates the Read ahead function when the following conditions exist:

- RCD is 0
- Read, Verify and Write and Verify is received.
- The consecutive LBA of the requested LBA is not available in the buffer

If SCSI reset or target reset message is received, all contents of segmented buffer is flushed.

Even if an error occurs during the Read ahead, the error will not be reported to the Initiator. The data read before the error occurred will be stored as valid data by the Read Ahead function.

## 20.9 Multiple Initiator Systems

This section describes how the target behaves in a multiple initiator system. Up to 64 initiators may be supported at any one time.

### 20.9.1 Sense Data

A separate sense data area is reserved for each initiator. Each area is maintained independently. This allows a command from one initiator to complete with a CHECK CONDITION status and generate sense data without being affected by a subsequent command from a different initiator. There is no requirement for the first initiator to send a REQUEST SENSE command to retrieve the Sense Data prior to the execution of a command from a different initiator.

### 20.9.2 Mode Pages

A single set of Mode pages is maintained. This includes both current and saved parameters. If a MODE SELECT command is executed that updates the current parameters, a unit attention condition is generated for all initiators except the one that issued the command. See 20.1.5, “Unit Attention Condition” on page 271 for more information.

## 20.10 Multiple Initiator Environment

### 20.10.1 Initiator Sense Data

Separate sense data is reserved for each I-T-L. Each sense data is maintained independent of commands from other initiators.

### 20.10.2 Initiator Mode Select/Mode Sense Parameters

A single shared copy of the Mode Select/Mode Sense parameters is maintained by the drive. This includes both the current and saved parameters.

## 20.11 Reset

Reset actions will return the drive to a known, initialized state.

This device supports the Hard reset option as defined in the SCSI standards (see 7.1.9 Dev\_Ctrl\_Code\_x on page 33) and the reset sources discussed below.

### 20.11.1 Reset Sources

There are four sources of resets detected by the target:

Reset Name	Reset Source
Power-On Reset	This is the signal generated by the hardware at initial power-on
Self-Initiated reset	This is a software-generated reset that occurs when a catastrophic error is detected by the microcode.
Hard Reset	This is the Hard Reset performed during a Link Reset Sequence.
LUN Reset	This is a LUN RESET TMF (08h) sent in a TASK IU.

### 20.11.2 Reset Actions

The action taken by the drive following a reset is dependent on the source of the reset.

#### 20.11.2.1 Power-On reset and Self-Initiated reset

These two reset conditions cause the following to be performed in the order shown:

- A power-up sequence
- A startup sequence is necessary to put the drive in a ready state

These reset conditions cause the following actions:

- If the reset occurs during the power-up sequence, the power-up sequence is re-started.
- If the auto-start option is enabled and a start-up sequence has not yet completed, the start-up sequence is restarted.  
Note: The power-up sequence is not re-run, since it has already completed.
- If the reset occurs while a physical sector is being written, the WRITE operation is disabled at the end of the current sector. The media is not corrupted if power is maintained to the end of the current sector.

## 20.12 Diagnostics

The drive will execute Power on Diagnostics at power on time to assure the correct operation of the drive by validating components (ROM, RAM, Sector Buffer, EEPROM, HDC, Spindle Motor, Actuator), checking stored information in the Reserved Area and EEPROM, and verifying fault detects circuits.

Self-test can be invoked by issuing a SEND DIAGNOSTIC command.

### 20.12.1 Power on Diagnostics

At power on time the following tests are executed:

1. Validation of ROM and EEPROM
2. RAM test for internal RAM
3. Test and Initialize HDC registers

4. RAM test for Sector Buffer
5. Start Spindle Motor (if enabled)
6. Calibration of Actuator
7. Read/Write test for all Heads
8. Validation of RAM code and data table (RDM, Log, Mode Page) from the Reserved Area

If Auto spin up is disabled, steps 5 - 8 will be executed by the first START STOP UNIT command which has the Start bit set.

Faults detected before successful completion of the HDC section could prevent the drive from responding to a selection.

Faults detected after the successful completion of the HDC test section will be reported as CHECK CONDITION status to the Initiator on the first command issued after a fault is detected (except for the INQUIRY, REPORT LUNS and REQUEST SENSE commands). The INQUIRY, REPORT LUNS and REQUEST SENSE commands will always be responded with a GOOD status. Detecting a fault during power on will not terminate execution of the tests nor will it terminate the power on process.

## 20.12.2 Self-test via SEND DIAGNOSTIC Command

### 20.12.2.1 Default Self-test

The default self-test is invoked by the SlfTst bit in the SEND DIAGNOSTIC command. The response is simply a GOOD status if the test is successful or a CHECK CONDITION status if the test fails.

The following tests are performed by the default self-test (in the order defined):

1. **Spin check** is to check if the spindle motor is running at the correct speed.
2. **Write, Read and Compare test** is a disk read/write test. It writes data to a predefined location in the reserved area and then reads it back and validates the content. All heads are tested.
3. **Seek test** is a servo test. It validates seeks to 256 random locations out of the full volume.

### 20.12.2.2 Short and Extended Self-tests

There are two other types of self-tests that may be invoked using the Function Code field in the SEND DIAGNOSTIC command: a short self-test and an extended self-test. The tests performed in the short and extended self-tests are described later. The time required by a logical unit to complete its extended self-test is specified in the Extended self-test Completion Time field in the Control Mode Page. The results of self-test can be retrieved via the LOG SENSE command for Log Page 10.

### 20.12.2.3 Self-test Modes

There are two modes for short and extended self-tests: a foreground mode and a background mode. These modes are described in the following clauses.

#### Foreground mode

When the drive receives a SEND DIAGNOSTIC command specifying a self-test to be performed in the foreground mode, the drive will return status for that command after the self-test has been completed. While performing a self-test in the foreground mode, the drive will respond to all commands except INQUIRY, REPORT LUNS, and REQUEST SENSE with a CHECK CONDITION status, a sense key of NOT READY and an additional sense code of LOGICAL UNIT NOT READY - SELF-TEST IN PROGRESS.

If the drive is performing a self-test in the foreground mode and a test error occurs, the drive will update the self-test results log page and report CHECK CONDITION status with a sense key of HARDWARE ERROR and an additional sense code of LOGICAL UNIT FAILED SELF-TEST. The application client may obtain additional information about the failure by reading the self-test results log page.

An application client may terminate a self-test that is being performed in the foreground mode using an ABORT TASK, ABORT TASK SET, or CLEAR TASK SET task management function. If the drive receives an ABORT TASK, ABORT TASK SET, or CLEAR TASK SET task management function while performing a self-test in the foreground mode, it will abort the self-test and update the self-test results log page.

## Background mode

When the drive receives a SEND DIAGNOSTIC command specifying a self-test to be performed in the background mode, the drive will return status for that command as soon as the command descriptor block has been validated. After returning status for the SEND DIAGNOSTIC command specifying a self-test to be performed in the background mode, the drive will initialize the self-test results log page as follows. The Function Code from the SEND DIAGNOSTIC command will be placed in the Function Code field in the log page. The self-test Results field shall be set to 0Fh. After the self-test results log page is initialized, the drive will begin the first self-test segment.

While the device server is performing a self-test in the background mode, it shall terminate with a CHECK CONDITION status any SEND DIAGNOSTIC command it receives that meets one of the following criteria:

- a. The SlfTst bit is one
- b. The Function Code field contains a value other than 000b or 100b.

When terminating the SEND DIAGNOSTIC command, the sense key shall be set to NOT READY and the additional sense code shall be set to LOGICAL UNIT NOT READY, SELF-TEST IN PROGRESS. While performing a self-test in the background mode, the drive will suspend the self-test to service any other command other than SEND DIAGNOSTIC (with Function Code field set to 100b) WRITE BUFFER (with the mode set to any download microcode option), FORMAT UNIT and START UNIT STOP command. Suspension of the self-test to service the command will occur within 2 seconds. If SEND DIAGNOSTIC (with Function Code field set to 100b), WRITE BUFFER (with the mode set to any download microcode option), FORMAT UNIT or START UNIT STOP command is received, the drive will abort the self-test, update the self-test log, and service the command within two seconds after the command descriptor block has been validated.

An application client may terminate a self-test that is being performed in the background mode by issuing a SEND DIAGNOSTIC command with the Function Code field set to 100b (Abort background self-test function).

### Elements common to foreground and background self-test modes

The Progress Indication field returned in response to a REQUEST SENSE command may be used by the application client at any time during execution of a self-test to poll the progress of the test. While executing a self-test unless an error has occurred, the drive will respond to a REQUEST SENSE command by returning a sense key of NOT READY and an additional sense code of LOGICAL UNIT NOT READY - SELF-TEST IN PROGRESS with the sense key specific bytes set for progress indication.

The application client may obtain information about the twenty most recently completed self-tests by reading the self-test results log page. This is the only method for an application client to obtain information about self-tests performed in the background mode. The default self-test results are not logged in the log page.



### Tests performed in the Short and Extended Self-test

The following table defines the tests performed in the short and extended self test. They are defined by their segment number which is also used to report Self-Test Results, in Log Sense Page 10. Note that the only difference between the Short and the Extended tests, is the sequential verify test in segment 7h. Also note that either of these tests can be run in foreground or background mode as previously described.

**Table 231: Short and Extended Self-Test Description**

Segment Number	Short Self-Test	Extended Self-Test	Test Description
1h	Drive Ready Test		Internal check to insure drive is “ready”, similar to a Test Unit Ready command.
2h	Drive Diagnostics		This test is comprised of the Default Self Test as defined in Section 20.12.2.1, “Default Self-test” on page 287
3h	SMART		Perform SMART testing and check results to ensure that SMART threshold criteria are not exceeded
4h	Low Level Format check		Check to insure that the media is currently not in the MEDIA FORMAT CORRUPTED state.
5h	Physical Head Check		Write/Read test on each head in a predefined location in the drive's Reserved Area of the disk.
6h	Random Verify		Perform 4000 random verify operations and insure no uncorrectable errors.
7h	- Verify First 300MB - Verify Last 100 MB	Verify all LBA's	Sequential verify operation. Ensure that no uncorrectable errors occur within the verify range.
8h	Recheck SMART		Same as segment 4h.

### 20.12.2.4 Background Medium Scan

For a related function, see .Mode Page 1C (Informational Exceptions Control).

## 20.13 Idle Time Function

The drive periodically saves data in logs and S.M.A.R.T. counters in the reserved area of the disks. The information is used by the drive to support various SCSI commands and for the purpose of failure analysis.

## 20.14 Command Time out Limits

The 'Command Time-out Limits' are defined as the time period from the SCSI Arbitration phase through the SCSI Task complete message, associated with a particular command.

The following times are for environments where Automatic Reallocation is disabled and there are no queued commands.

### 20.14.1 Reassignment Time

The drive should be allowed a minimum of 5 seconds to complete a "Reassign Blocks" command.

### 20.14.2 Format Time

Approximately 7.5 / 5.5 hours should be allowed for 3 / 2 TB capacity drives to complete a "Format Unit" command when certification is disabled. Allow 15 / 11 hours when certification is enabled. If "Fast Format" is enabled via the FFMT bit in mode page 00h, allow 30 seconds for completion.

### 20.14.3 Start/Stop Unit Time

The drive should be allowed a minimum of 30 seconds to complete a "Start Stop Unit" command (with Immed bit = 0). Initiators should also use this time to allow startup sequences initiated by auto start ups and "Start Stop Unit" commands (with Immed bit = 1) to complete and place the drive in a "ready for use" state.

**Note:** A time-out of one minute or more is recommended but NOT required. The larger system time-out limit allows the system to take advantage of the extensive ERP/DRP that the drive may attempt in order to successfully complete the startup sequence.

**Note:** For SAS devices a NOTIFY(Enable Spinup) primitive is required prior to actually starting to spin up the spindle motor (regardless of whether a Start Stop Command with the Start bit set, was received or not).

## 20.14.4 Medium Access Command Time

The time-out limit for medium access commands that transfer user data or non-user data or both should be a minimum of 30 seconds. These commands are

- Pre-Fetch
- Read
- Read Defect Data
- Seek
- Send Diagnostic (Function Code = 0)
- Read Long
- Reassign Blocks
- Write
- Write and Verify
- Write Buffer
- Write Same
- Verify

Note: The 30-second limit assumes the absence of bus contention and data transfers of 64 blocks or less. This time should be adjusted for anticipated bus contention and if longer user data transfers are requested.

## 20.14.5 Time-out Limits for Other Commands

The drive should be allowed a minimum of 5 seconds to complete these commands:

- Inquiry
- Log Select
- Log Sense
- Mode Select
- Mode Sense
- Persistent Reserve In/Out
- Read Buffer
- Read Capacity
- Read Long
- Release
- Request Sense
- Reserve
- Set/Report Device Identifier
- Start/Stop Unit (with Immed bit = 1)
- Synchronize Cache
- Test Unit Ready
- Writer Long

The command time-out for a command that is not located at the head of the command queue should be increased by the sum of command time-outs for all of the commands that are performed before it is.

## 20.15 Recommended Initiator ERP

The Drive's design points for error reporting to the system assumes certain system action for the error return codes. These assumptions are:

1. SCSI protocol will be the first priority in reporting errors.
2. The system will maintain a log of all reported errors.
3. System architecture should include all error handling recommendations made in this section. Deviations should have mutual agreement between Drive development and system integration.

This section is directed toward documenting the assumptions made by the Drive that the system is expected to implement. The two error classes that the system should be concerned with are DATA and NON-DATA errors.

Data errors are those errors that deal with the handling of data to and from the MEDIA and are identified by the Additional Sense Code contained in the sense data. The Additional Sense Codes for data errors are as follows:

- OC - Write error
- 11 - Unrecovered read error
- 14 - No record found
- 16 - Data Synchronization mark error
- 17 - Recovered read error without LDPC correction
- 18 - Recovered read error with LDPC correction

Typically, data errors do not include positioning of the heads or the data path though the electronics.

Nondata errors are those errors that do not have a direct relationship with transferring data to and from the media. Nondata errors can include data handling if the media is not associated with the error (that is, interface error).

The system action assumed for each class of error is outlined here.

### 20.15.1 Drive Service Strategy

The Drive service strategy is defined so the customer will be able to use the system as soon after a failure is detected as possible. The first priority is to replace the entire drive to make the system operational with minimal service time. The service representative should:

1. Back up all the customer data on this drive if possible
2. Replace the complete drive
3. Restore the customer data
4. Return the drive to customer service

## 20.15.2 Recommendations for System Error Log

The system error log should contain information about the Drive error that will allow recovery actions. The system error logs should contain all the error information returned in the sense data. At a minimum, the following information about each error occurrence should be logged.

- Valid bit and error code (Sense byte 0)
- Sense Key (Sense byte 2)
- Information bytes (Sense bytes 3 through 6)
- Command specific information (Sense bytes 8 through 11)
- Additional Sense Code (Sense byte 12)
- Additional Sense Code Qualifier (Sense byte 13)
- Field Replaceable Unit (Sense byte 14)
- Sense Key Specific (Sense bytes 15, 16, and 17)
- Vendor Unique error information (Sense bytes 20 through 23)

## 20.15.3 Data Recovery Procedure

Statistically, most data error activity is noise related and has nothing to do with defects in the media. It is wrong for the system to assume that every data error reported occurred because of a defect in the media. It is also wrong for the system to assume that every data error that occurred because of a media defect rendered the Drive unusable.

Recurring data error activity at the same physical location is an indication of a problem. The problem can be due to a media defect or magnetic damage. A media defect is physical damage to the recording capability of the media while magnetic damage is a defect in the bit pattern written to the media.

In both cases, the error can be corrected without replacing the unit. The physical sector may require relocation. The Drive determines the need to reassign a sector. The Mode Select Page 1 option bit ARRE (See Section 18.10.3, “Mode Page 01 (Read/Write Error Recovery Parameters)” on page 138) set active allows the Drive to relocate recovered read data errors. Non recovered data errors or the ARRE bit being inactive will have additional sense codes returned to recommend reassignment of sectors.

The need to reassign a sector should be infrequent. Sites not meeting error rate criteria are removed from use during SAT (Surface Analysis Test) in Drive manufacturing. With the exception of some early life SAT escapes (sites that were marginally missed during SAT), reassigning defective sectors should be rare. Frequent sector reassignment may be an (early) indication of another type of failure. Sector reassignments are monitored as part of the predictive failure analysis. When a threshold is exceeded, the Drive will notify the initiator that a scheduled service action is required.

Drive soft error rates are based on extraneous random faults that are not predictable. Media defects discovered after the Drive completes manufacturing final test need to be relocated so that soft error rates are not influenced by predictable known error sites. Failure of the system to properly relocate defective media sites can have a direct influence on system throughput and drive error rates.

### 20.15.3.1 Reassign a Physical Sector

The Drive determines the need to reassign physical sectors based on error activity. Once a physical sector requires reassignment, the Drive will either reassign the physical sector, or recommend to the initiator that the LBA associated with the physical sector be reassigned.

When the following Sense Key, Additional Sense Code, and Additional Sense Code Qualifier combinations are returned, the initiator should reassign the LBA reported at the next opportunity.

**Note:** In Table 232, the Key, Code, and Qualifier fields are all hex values (i.e., Sense Key 1 is 1h, Sense Code 17 is 17h, etc.).

**Table 232: Recommend Reassign Errors**

Key	Code	Qual	Description
1	17	07	Recovered Data without LDPC - Recommend Reassignment
1	18	05	Recovered Data with LDPC - Recommend Reassignment

To reassign an LBA that has sense data recommending a reassignment, the initiator should:

1. Attempt to recover the data from the sector being reassigned with a Read (08) or Read (28) command.
2. Reassign the LBA using the Reassign Blocks (07) command.
  - If the reassignment completes successfully (Good Status), log the error in the system error log.
  - If the reassignment completes unsuccessfully (Check Condition Status), follow the procedure in Section 20.15.3.3, “Reassign Blocks Recovery” on page 295.
3. Write the LBA that was reassigned.

### 20.15.3.2 Data Error Logging

The Drive will report data errors to the initiator that do not require immediate action (successful auto reallocation, successful auto rewrite, or no action needed on this occurrence). The initiator should log these errors in the system error log. No other action is required.

**Table 233: Log Only Errors**

Key	Code	Qual	Description
1	16	00	Data Synchronization Mark Error
1	17	01	Recovered Data with Retries
1	17	06	Recovered Data without LDPC - Auto Reallocated
1	17	09	Recovered Data without LDPC - Data Rewritten
1	18	00	Recovered Data with LDPC
1	18	02	Recovered Data with LDPC - Auto Reallocated
1	18	07	Recovered Data with LDPC - Data Rewritten

### 20.15.3.3 Reassign Blocks Recovery

The Drive provides the capability to remove media defects without reducing capacity. If the mode parameter bit ARRE is active, the Drive will automatically reallocate LBA's determined to be defective. For those LBA's where the error is unrecoverable or the initiator elects to not have the Drive automatically reallocate LBA's, the Drive will recommend reassignment of the LBA.

Recovery from a failed reassignment consists of the following actions:

- Updating the defect descriptor to remove the LBA's that have been successfully reassigned and then retry the Reassign Blocks command. The LBA contained in the Command Specific Information field of the Sense Data is the LBA in the first defect descriptor that was not reassigned because of the failure. If the command failed because of an unrecoverable read error other than those specified in the defect descriptor, add this LBA to the defect descriptor and retry the command. Refer to Section 18.28, "REASSIGN BLOCKS (07)" on page 203, for additional information.
- If the retried Reassign Blocks (07) command completes successfully, returning to normal processing.
- If the retried Reassign Blocks (07) command fails, servicing the drive using the service guidelines recommended in Section 20.15.1, "Drive Service Strategy" on page 292.

### 20.15.4 Nondata Error Recovery Procedure

The Drive will follow a logical recovery procedure for nondata errors. The initiator options for non-data errors are limited to logging the error, retrying the failing command, or replacing the drive.

These recovery procedures assume the initiator practices data back-up and logs errors at the system level for interrogation by service personnel.

#### 20.15.4.1 Drive Busy

The Drive is busy performing an operation. **This is not an error condition.** The initiator can test for completion of the operation by issuing *Test Unit Ready (00)* (or media access) commands.

- If the *Test Unit Ready (00)* (or media access) command completes with *Check Condition Status* then issue a *Request Sense (03)*
  - If the specified recovery procedure for the sense data is for a condition other than drive busy, follow the recovery procedure for the condition reported.
  - If the specified recovery procedure for the sense data is for a drive busy condition, then continue re-issuing the *Test Unit Ready (00)* and *Request Sense* commands for the duration of a media access time-out or until the drive returns *Good Status*.
  - If the drive has been busy for longer than the limit specified in Section 20.14, "Command Time out Limits" on page 290, then service the drive using the service guidelines recommended in Section 20.15.1, "Drive Service Strategy" on page 292. Otherwise return to normal processing.
- If the *Test Unit Ready (00)* (or media access) command completes with *Good Status*, then return to normal processing.

#### 20.15.4.2 Unrecovered Drive Error

The initiator should retry the failing command.

1. If the retry of the failing command completes with *Good Status* or recovered Sense Key, follow the recovery procedure in Section 20.15.4.3, "Recovered Drive Error" on page 296.
2. If the retry of the failing command completes with hardware error sense, verify there is no outside cause (e.g., power supply) for the failure, then retry the failing command.
  - a. If the retry of the failing command completes with *Good Status*, follow the recovery procedure in next Section 20.15.4.3, "Recovered Drive Error" on page 296.
  - b. If the retry of the failing command completes with Recovered sense or Hardware error sense, then service the drive using the service guideline recommended in Section 20.15.1, "Drive Service Strategy" on page 292.

### 20.15.4.3 Recovered Drive Error

The Initiator should log the error as soft with the recovery level.

### 20.15.4.4 Drive Not Ready

The initiator should do the following:

1. Issue a *Start Stop Unit (1B)* command.
2. Verify that the drive comes ready within the time specified in Section 4.5.2, “Drive ready time” on page 10.
3. If the drive fails to come ready within the specified time, service the drive using the service guidelines specified in Section 20.15.1, “Drive Service Strategy” on page 292.
4. Retry the failing command.
  - a. If the failing command completes with *Good Status*, log the error as recovered.
  - b. If the failing command completes with Not Ready sense, verify there is no outside cause (for example, the power supply). Then service the drive using the service guidelines specified in Section 20.15.1, “Drive Service Strategy” on page 292.

### 20.15.4.5 No Defect Spare

Three conditions can cause this error:

1. When the *Reassign Blocks (07)* command is issued and there are no spares available for the Drive to use for the relocation requested.
2. When the Glist is full and the sector to be reassigned cannot be added.
3. During a format operation, there was not enough space available to fulfill the spare requirement (Dlist is too large).

Service the Drive following Section 20.15.1, “Drive Service Strategy” on page 292.

### 20.15.4.6 Degraded Mode

Refer to Section 20.1.9, “Degraded Mode” on page 274, for the definition of this state. There are three causes for entering degraded mode. In all cases the Sense Key is *Not Ready*. The causes are the following:

1. Sense Code/Qualifier of *Logical Unit Not Ready, initializing command required*. The spindle motor not spinning or not at the proper speed. This may not be an error condition. The initiator should issue a *Unit start (1B)* command to start the spindle motor. If the Drive fails to come ready in the time specified in Section 20.14, “Command Time out Limits” on page 290, service the drive using the service guideline recommended in Section 20.15.1, “Drive Service Strategy” on page 292.
2. Sense Code/Qualifier of *Diagnostic Failure*. Failure of a Send Diagnostic self test, a start up sequence, or other internal target failures.
  - Failure of a send diagnostic self test or a start up sequence.

This failure is the result of the diagnostics that are executed during power on or when the *Send Diagnostic (1D)* command is executed detecting a failure. As with the RAM code not loaded and the configuration data not loaded, the recovery is either a power cycle or issuing the *Send Diagnostic (1D)* command with the self test bit set active. Recovery for a failed Send Diagnostic (1D) is achieved in one of the following ways:

Executing the Send Diagnostic (1D) command

Power cycling the drive

If the failure repeats, service the drive using the service guideline recommended in Section 20.15.1, “Drive Service Strategy” on page 292.

Recovery for a failed power up sequence is achieved in one of the following ways:

Issuing a Unit start (1B) command

Power cycling the drive.

If the failure repeats, service the drive using the service guideline recommended in Section 20.15.1, “Drive Service Strategy” on page 292.



- Internal target failures

The drive periodically adjusts the track following for each head to compensate for expansion and contraction of the disks due to temperature changes. If one of these adjustments fails, the drive will enter a degraded mode to prevent writing data off track.

Recovery of this condition is either a power cycle or successful completion of the Send Diagnostic (1D). Service the drive using the recommended service guidelines specified in Section 20.15.1, “Drive Service Strategy” on page 292, if the power cycle or the Send Diagnostic (1D) command fail to complete successfully.

3. Sense Code/Qualifier of **Format Command Failed** Format Unit (04), Sense Code/Qualifier of **Medium Format Corrupted Reassign Failed** Reassign Blocks (07) command, or an automatic reallocation failed or was abnormally terminated.

Recovery from a failed Format Unit (04) is achieved by retrying the command. If the command fails a second time, service the drive following the procedure defined in Section 20.15.1, “Drive Service Strategy” on page 292.

If the above defined recovery procedures fail to clear the degraded mode condition, the Drive should be replaced. Follow the procedure in Section 20.15.1, “Drive Service Strategy” on page 292, when replacing the drive.

#### 20.15.4.7 Reserved Area Hard Error

Sectors found defective in the reserved area of the disk cannot be reassigned after the Drive leaves the factory. The data in the reserved area is not directly accessible by the initiator. For this reason, the reserved area has all data. A data error must occur in both copies of the data record before the Drive considers a reserved area read error. When this happens, the integrity of the drive is questionable.

Service the Drive using Section 20.15.1, “Drive Service Strategy” on page 292.

#### 20.15.4.8 Interface Protocol

For all interface protocol errors, the initiator should complete the following steps:

1. Correct the parameter that caused the Illegal Request
2. Retry the failing command
3. If the first retry of the failing command completes with
  - *Good Status*, log the error as recovered
  - *Check Condition Status* with sense data for an Illegal Request, verify there is no outside cause (for example, the power supply) for the failure
  - *Other*, follow the recommendations for the error condition reported. Retry the failing command. If this retry of the failing command completes with
    - *Good Status*, log the error as recovered
    - *Check Condition Status* with sense data for an Illegal Request, service the drive using the service guideline recommended in Section 20.15.1, “Drive Service Strategy” on page 292.
    - *Other*, follow the recommendations for the error condition reported.

#### 20.15.4.9 Aborted Command

The initiator should determine the cause from the Additional Sense Code (byte 12):

- Sense Key = B (Aborted Command) with Additional Sense Codes of 1B, 25, 43, 49, and 4E are initiator caused abort conditions. The initiator should correct the condition that caused the abort and retry the failing command.
- Sense Key = B (Aborted Command) with Additional Sense Code of 44 or 48 are drive caused abort conditions. The initiator should:
  1. Retry the failing command.
  2. If the retry of the failing command completes with

- *Good Status*, log the error as recovered.
  - Abort Command Sense, verify there is no outside cause (e.g. power supply) for the failure.
3. Retry the failing command.
  4. If the retry of the failing command completes with
    - *Good Status*, log the error as recovered.
    - Abort command sense, then service the drive using the service guideline recommended in Section 20.15.1, “Drive Service Strategy” on page 292.
- Sense Key = B (Aborted Command) and an Additional Sense Code of 47 can be an initiator or Drive caused abort condition. The initiator should follow the above procedure for initiator caused abort conditions if the Drive detected the SCSI bus parity error. The initiator should follow the above procedure for Drive caused abort conditions if the initiator detected the SCSI bus parity error.

#### **20.15.4.10 Unit Attention Condition**

Unit Attention Conditions are not errors. They alert the initiator that the drive had an action that may have changed an initiator controlled state in the drive. These conditions are the following:

##### **Not Ready to Ready Transition**

Not ready to ready transition, unit formatted. This *Unit Attention Condition* will not be reported to the initiator that issued the *Format Unit (04)*.

##### **Reset**

Reset - This means the drive was reset by either a power-on reset, Hard Reset, LUN Reset TMF or an internal reset.

##### **Mode Parameters Changed**

A *Mode Select (15)* command successfully completed. This means that the mode parameters that are the current value may have changed. The parameters may or may not have changed but the command to change the parameters successfully completed. The Drive does not actually compare the old current and the new current parameters to determine if the parameters changed. This *Unit Attention Condition* will not be reported to the initiator that issued the *Mode Select (15)*.

##### **Microcode Has Changed**

*Write Buffer (3B)* to download microcode has successfully completed. This means that the microcode that controls the Drive has been changed. The code may or may not be the same as the code currently being executed. The Drive does not compare old level code with new code.

##### **Commands Cleared by Another Initiator**

Tagged commands cleared by a clear queue message. This means that the command queue has been cleared. The *Unit Attention Condition* is not reported to the initiator that issued the clear queue message. *Unit Attention Condition* is reported to all initiators that had commands active or queued.

Reissue any outstanding command.

##### **Log Select Parameters Changed**

A Log Select (4C) command successfully completed. This means that the Log Select command cleared statistical information successfully (See Section 18.6, “LOG SELECT (4C)” on page 95). Unit Attention Condition is reported to all initiators excluding the initiator that issued the Log Select command.

##### **Device Identifier Changed**

A Set Device Identifier (A4) command successfully completed. This means that the Set Device Identifier information field has been updated. (See 18.41, “SET DEVICE IDENTIFIER (A4/06)” on page 230) A Unit Attention Condition is reported to all initiators excluding the initiator that issued the Set Device Identifier command.

### 20.15.4.11 Components Mismatch

The compatibility test is performed at a power cycle. The compatibility test verifies the microcode version of the electronics. When the Drive detects the microcode version mismatch, the most likely cause is the result of incorrect parts used during a service action.

If the error reported is Key/code/qualifier 4/40/80, Diagnostic failure, bring-up fail, the initiator should do the following:

1. Retry Power cycle
2. Check the send diagnostic end status. If the status is
  - GOOD, Return to normal processing
  - *Check Condition Status*, issue a *Request Sense (03)* and follow the recommendations for the sense data returned unless the sense data is for a component mismatch. If the sense data is for component mismatch, service the drive using the service guideline recommended in Section 20.15.1, “Drive Service Strategy” on page 292.

### 20.15.4.12 Self Initiated Reset

The Drive will initiate a self reset when the condition of the Drive cannot be determined. The internal reset will terminate any outstanding commands, release any reserved initiators, and stop the spindle motor. The initiator can recover by

1. Logging the error
2. Retrying the failing command. If the failing command completes with:
  - *Good Status*, return to normal processing
  - Self initiated reset sense, service the drive according the guidelines recommended in Section 20.15.1, “Drive Service Strategy” on page 292.
  - Other, follow the recommendations for the error reported.

### 20.15.4.13 Defect List Recovery

**This is not an error condition.**

The initiator either requested a defect list in a format (block or vendor specific) that the Drive does not support or the requested defect list(s) exceed the maximum list length that can be returned. If the Sense Key/Code/Qualifier are:

1/1F/00, the requested list(s) exceed the maximum length that can be supported. The initiator should request one list at a time. If a single list exceeds the maximum returnable length, this may be an indication of a marginally operational drive. Service the drive following the service guidelines in Section 20.15.1, “Drive Service Strategy” on page 292.

1/1C/01 or 1/1C/02, the requested defect list is not in the format that the Drive supports. The requested defect list is returned in the physical (cylinder, sector, head) format. This is the default format. There is no initiator action required for this condition.

#### 20.15.4.14 Mismatch Recovery

A mismatch can occur on a *Verify (2F)* command or a *Write and Verify (2E)* with the byte check (BytChk) bit active. Recovery for a mismatch error is different for the two commands.

##### Verify Command

The initiator should do the following:

1. Verify that the data sent to the drive is the correct data for the byte-by-byte compare.
2. Read the data from the media with a *Read (08)* or *Read (28)* command and verify that the data from the media is the expected data for the byte-by-byte compare.
  - If all data are correct, this is an indication that the data may have been read from the media incorrectly without an error detected. Service the drive using the procedure specified in Section 20.15.1, “Drive Service Strategy” on page 292.
  - If all data are not correct, this is an indication that the data on the media is not the data the initiator expected. Rewrite the correct data to the media.

##### Write and Verify Command

The drive uses the same data in the data buffer to write then read and compare. A mismatch error on the *Write and Verify (2E)* command is an indication that the drive cannot reliably write or read the media. Service the drive using the procedures specified in Section 20.15.1, “Drive Service Strategy” on page 292.

#### 20.15.4.15 Microcode Error

The microcode from the interface is validated before the device operates using that microcode. When the validation detects incorrect or incomplete data, the Drive enters degraded mode.

If the initiator attempted to load microcode using the *Write Buffer (3B)* retry the *Write Buffer (3B)*. If the command completes with

- *Good Status* - return to normal processing
- *Check Condition Status* - service the drive using the service guidelines recommended in Section 20.15.1, “Drive Service Strategy” on page 292.

If the check sum error occurred during normal processing, the initiator may attempt to load microcode before deciding to service the drive using the service guidelines recommended in Section 20.15.1, “Drive Service Strategy” on page 292.

To load new microcode, the initiator should issue a *Write Buffer (3B)* command with the download and save option. If the *Write Buffer (3B)* command completes with

- *Good Status*, return to normal processing. Retry the failing command. If the task complete with
  - *Good Status* - Continue normal processing.
  - *Check Condition Status* for check sum error - Service the drive using the service guidelines recommended in Section 20.15.1, “Drive Service Strategy” on page 292.
  - *Check Condition Status* for any other error - follow the recommended recovery procedure for the error reported.
- *Check Condition Status* for Check sum error, service the drive using the service guidelines recommended in Section 20.15.1, “Drive Service Strategy” on page 292.
- *Check Condition Status* for any other error, follow the recommendations for the returned sense data.

#### **20.15.4.16 Predictive Failure Analysis**

The Drive performs error log analysis and will alert the initiator of a potential failure. The initiator should determine if this device is the only device with error activity.

If this drive is the only drive attached to the initiator with error activity, service the drive using the procedures specified in Section 20.15.1, “Drive Service Strategy” on page 292.

**Note:** Service for this drive can be deferred. The longer service is deferred, the more probable a failure can occur that will require immediate service.

If more than this drive is experiencing error activity, the drive is probably not at fault. Locate and service the outside source causing error activity on this drive.



## 21.0 TCG SSC

This chapter provides information on HGST encryption-specific HDD firmware and features. It is assumed that the reader is familiar with the referenced specifications and industry standards.

### 21.1 Referenced Specifications and Standards

#### 21.1.1 TCG Specifications

This section references 3 separate TCG specifications, which are available on the TCG website:

(<http://www.trustedcomputinggroup.org/>):

1. TCG Core Specification, Version 1.0, Revision 0.9
  - The TCG Core Specification is the general specification for trusted computing that encompasses all classes of devices, including storage
2. TCG Storage Interface Interactions Specification (SIIF), Version 1.0, 1/27/2009
  - Specifies the interaction between the HDD and the SCSI/ATA protocols
3. TCG Storage Security Subsystem Class (SSC): Enterprise, Version 1.0, rev 1.0, spec dated 1/27/09
  - A Security Subsystem Class defines minimum acceptable Core Specification capabilities of a storage device in a specific class (in our case – enterprise).
  - Storage devices in specific classes may have a subset of the capabilities that are defined in the core specification

#### 21.1.2 Federal Information Processing Standards (FIPS)

This section references the following Federal Information Processing Standards, published by the US National Institute of Standards (NIST), which are available on the NIST website (<http://www.itl.nist.gov/fipspubs/>):

1. FIPS 197, Advanced Encryption Standard (AES), 2001 November 26. <http://csrc.nist.gov/publications/fips/fips197/fips-197.pdf>
2. FIPS 180-3, Secure Hash Standard (SHS) [http://csrc.nist.gov/publications/fips/fips180-3/fips180-3\\_final.pdf](http://csrc.nist.gov/publications/fips/fips180-3/fips180-3_final.pdf)
3. FIPS 140-2, Security Requirements for Cryptographic Modules – 01 May 25 (Supersedes FIPS PUB 140-1, 1994 January 11) <http://csrc.nist.gov/publications/fips/fips140-2/fips1402.pdf>

#### 21.1.3 National Institute of Standards (NIST)

This section references the following NIST publications, available on the NIST website (<http://www.nist.gov/index.html>)

1. NIST Special Publication 800-90, Recommendation for Random Number Generation Using Deterministic Random Bit Generators (Revised), [http://csrc.nist.gov/publications/nistpubs/800-90/SP800-90revised\\_March2007.pdf](http://csrc.nist.gov/publications/nistpubs/800-90/SP800-90revised_March2007.pdf)

#### 21.1.4 Department of Defense

- DoD 5220.22-M, "National Industrial Security Program Operating Manual", 2/28/2006 <http://www.dtic.mil/whs/directives/corres/pdf/522022m.pdf>

- DoD 5220.22-M Supplement 1, “National Industrial Security Program Operating Manual Supplement”, 02/1995 - <http://www.dtic.mil/whs/directives/corres/pdf/522022MSup1.pdf>

### 21.1.5 RSA Laboratories Standards

1. RSA-PSS - <http://www.rsa.com/rsalabs/node.asp?id=2146>
2. RSA PKCS #5 v2.0 Password-Based Cryptography Standard - <ftp://ftp.rsasecurity.com/pub/pkcs/pkcs-5v2/pkcs5v2-0.doc>

### 21.1.6 Other Standards

1. T10 SCSI Standard.(T10 homepage - (<http://www.t10.org/index.html>))

## 21.2 Implementation Exceptions

The following is a list that describes non-compliance with the TCG Enterprise SSC specification:

- The SSC specification requires support for 1024 bands, but the implementation supports up to 64 bands.
- The K\_AES\_256 table was implemented with only the **UID** and **MODE** columns.
- At any given time, the implementation allows for only 1 active session. In the case when a session is active and a new session is requested, the drive answers the host with SP\_BUSY, instead of NO\_SESSIONS\_AVAILABLE

## 21.3 Implementation Features and Details Outside of TCG Specifications

The following features are outside of the TCG specifications.

1. Ports
2. Firmware signing

The following implementation details are outside of the TCG SSC specification.

- a. The SSC States “The TPer SHALL implement the ParamCheck Longitudinal Redundancy Check (LRC) for Get and Set method calls on a PIN value”. If the LRC check is erroneously applied to a value other than a PIN we ignore it, therefore no error is generated.
- b. When handling a "TCG cmd followed by a R/W cmd", all reads and writes that follow a TCG command will be processed in the normal way. No special handling or error messages will be sent to the host. It is up to the host to understand the possible outcomes of TCG commands and r/w command ordering and plan accordingly.
- c. CRC checking is disabled in all cases, so the drive will return data to the host. If the user successfully authenticates, then unencrypted data is returned to the host. If the user is unable to authenticate, encrypted data is returned to the host.
- d. The TPer replies with SP\_BUSY for requests beyond 1 session.



## 21.4 Encryption Algorithms

### 21.4.1 Advanced Encryption Standard (AES) Support

AES encryption is implemented in hardware, with support for ECB or XTS mode for 128 bit or 256 bit keys. A single key is active at any one time within the AES hardware engine. Firmware is responsible for reading the keys from the hardware and also for determining which key is attached to a given LBA range; the hardware can only detect if the LBA has been encrypted or not. The TCG protocol does not allow for a user to choose or switch between AES algorithms, so it is up to the vendor to choose which AES algorithm is used in their implementation. The HGST TCG SSC implementation in firmware supports AES 256-XTS only.

### 21.4.2 Level 0 Discovery Vendor Specific Data

This section refers to section 10.2.14 of the TCG Storage Security Subsystem Class document (see the Specifications section of this document). Table 2 of Section 10.2.14 displays a "Vendor Specific" section in bytes 16 to 47. This Vendor Specific section is documented below.

**Table 234: Persistent Reserve In (5E)**

Byte	Bit							
	7	6	5	4	3	2	1	0
16	Version (set to 0)							
17	Vendor Specific State Information							
18	Reserved							
19	RSVD	MB_s	0	0	Diag_s	Dload_s	Locking_s	FDE_s
20	Reserved							
21	RSVD	MB_e	0	0	Diag_s	Dload_e	Locking_e	FDE_e
22-47	Reserved							

FDE\_s/FDE\_e - Full disk encryption is Supported (equivalent to Media Encryption in Locking Feature Descriptor Enterprise SSC 10.2.14) / Full disk encryption is Enabled on one or more band.

Locking\_s/Locking\_e - LBA band locking is supported - locking object exists in the locking SP of the device (equivalent to Locking Enabled in Locking Feature Descriptor Enterprise SSC 10.2.14) / The locking object for a band has either Read-Locked or WriteLocked attribute set (equivalent to Locked in Locking Feature Descriptor Enterprise SSC 10.2.14).

Dload\_s/Dload\_e - support for Admin SP Firmware download port / Firmware download port via Admin SP is locked.

Diag\_s/Diag\_e - Support for Admin SP vendor specific Diagnostic port / Diagnostics port via Admin SP is locked.

MB\_s/MB\_e - Multiple encrypting bands supported / Multiple encrypting bands enabled. This bit shall be set to 1 if more than one band exists in addition to the global band and is defined with at least one LBA.

### 21.4.2.1 T10 End-To-End Data Protection

AES encryption is performed after T10 end-to-end data protection data has been added, so that the T10 information is encrypted along with the customer data.

### 21.4.3 Pseudo Random Number Generation (PRNG)

Pseudo-random number generation is implemented using the NIST SP800-90 PRNG. This PRNG uses AES as a primitive both for entropy mixing and entropy output. The successive values of the state of the PRNG are kept private to the device to ensure that keys generated by the device are unpredictable. The PRNG seed is derived from head position noise and has been measured to be uniformly distributed.

### 21.4.4 Key Wrapping

The NIST AES Key Wrapping Algorithm is used to encrypt a key with another key (KEK= Key Encryption Key). For any band *i*, the KEK<sub>*i*</sub> is derived from PIN<sub>*i*</sub> and salt<sub>*i*</sub> using the PBKDF2(**Password-Based Key Derivation Function**) algorithm. Then, the KEK<sub>*i*</sub> is used to wrap the media encryption key using the NIST key wrapping algorithm.

### 21.4.5 Key Erasure

Cryptographic erase procedure

- Erase and overwrite wrapped key material with 0x00.
- Erase and store the new wrapped key material.

## 21.5 -TCG SSC Tables

Two copies of all TCG SCC tables and data structures are stored in the RID; one is used as a primary copy and the other as a backup copy. The backup copy is used in the event the primary copy becomes corrupted. Each time a write is executed to any TCG table, both the primary and backup copies of the tables are updated and saved in the RID. In the case of a corrupted copy, the good copy is always used to restore the corrupted copy to the correct state. If both copies of the tables become corrupted during operation, the tables will be reinitialized to default values automatically, and this will result in a key mismatch error when a read is attempted.

The default values in the TCG tables created at the time of manufacturing are per the TCG SSC specification. The following tables contain VU (Vendor Unique) entries, which are set at the time of manufacturing.

- Admin SP C\_PIN table
- Locking C\_PIN table
- K\_AES\_256 table
- Locking SP Locking Access Control table
- LockingInfo Table
- Locking SP Locking Table

The VU entries for these tables are specified below. In addition, explanation of default values is given for non-VU entries that require it.

### 21.5.1 Admin SP C\_PIN Table and Locking SP C\_PIN Table

Per TCG SSC specification, the PIN is set to the MSID at manufacturing time. HGST has specified the MSID to be the serial number of the drive concatenated 4x. **TryLimit** is set to 0, meaning that there is no limit. **Tries** is set 0, meaning that there have been no fail attempts. **Persistence** is set to 0, meaning the “**Tries**” value does not persist through power cycles (The “**Tries**” value is reset to 0 after successful attempt or a power cycle).

**Table 235: HGST Implementation of Admin SP\_CPIN & Locking C\_PIN**

..	PIN	TryLimit	Tries	Persistence
..	MSID	0	0	0
..	MSID	0	0	0
..	..	..	..	..
..	MSID	0	0	0

### 21.5.2 K\_AES\_256 Table

The K\_AES\_256 table has 64 rows, one row for each band that can be allocated by the user. The first row is for the “global range”, also known as Band 0. This table was implemented without the “Name”, “CommonName”, and “Key” Columns.

**Table 236: HGST Implementation of K\_AES\_256 Table**

UID (8 byte hex)	MODE
00 00 08 06 00 00 00 01	23
00 00 08 06 00 00 00 02	23
..	..
00 00 08 06 00 00 00 40	23

The mode is specified in the TCG Enterprise SSC as a “Vendor Unique” (VU) entry. HGST initializes it in manufacturing to **mode=23** (media encryption mode, per TCG specification) for all 64 entries.

### 21.5.3 Locking SP AccessControl Table

The TCG Enterprise SSC defines the values for Row Number and UID as “Vendor Unique” (VU). HGST has defined them to be the row number in the table, with a range of 0-459. The range is calculated using the following formula:

$number\_of\_rows = (\#SupportedBands * 7) + 12$ , where

- #SupportedBands = 64 (The implementation supports 64 bands)
- The number 7 comes from the fact that each band has 7 UID/method combinations
- The number 12 comes from the following 12 methods that must be included in the table.
  1. ThisSp / Authenticate
  2. AuthorityTable/Next
  3. Anybody Authority Object/ Get
  4. BandMasters Authority Object/ Get
  5. EraseMaster Auth. Object / Get

6. C\_PIN table / Next
7. EraseMaster C\_PIN Object/ Set
8. LockingInfo Table / Get
9. Locking Table / Next
10. DataStore / Get
11. DataStore / Set
12. ThisSP / Random

**Table 237: HGST Implementation of Locking SP Access Control Table**

Row Number	UID	.
0	0	.
1	1	.
.	.	.
459	459	.

### 21.5.4 Locking Info Table

As specified in the TCG Enterprise SSC, this table has only 1 row. The “Vendor Unique” entries are specified in the table below. Encryption Support is initialized to **EncryptionSupport=23** (media encryption mode) in manufacturing.

**Table 238: HGST Implementation of Locking Info Table**

.	NAME	Version	.	Encrypt Support	MaxRanges	MaxReEncryptions	KeysAvailable Cfg
.	0	0	.	23	0	0	0

### 21.5.5 Locking SP Locking Table

The “Vendor Unique” (VU) values for this table are shown below.

**Table 239: HGST Implementation of Locking SP Locking Table**

.	NextKey	ReEncrypt State	ReEncrypt Request	AdvKey Mode	VerfMode	ContOn Reset	LastReEncrypt LBA	LastRe EncStat	General Status
.	00 00 00 00 00 00 00 00h	0	0	0	0	0	0	0	0
.	.	.	.	.	.	.	.	.	.
.	00 00 00 00 00 00 00 00h	0	0	0	0	0	0	0	0

In the **ActiveKey** column, the Enterprise SCC allows for byte 3 to be defined as either 05 or 06. The HGST implementation

uses 06.

## 21.6 Firmware Download and Signing

The HGST Firmware signing and download for encryption drives is meant to provide a mechanism for secure updates through the Host interface. Firmware is downloaded to the drive through the host interface, and the signature is verified using a public key installed in the reserved area during manufacturing, before it is loaded to RAM or installed in the reserved area on the HDD.

Signature verification uses the RSA-PSS (Probabilistic Signature Scheme) signature verification algorithm with EMSA-SHA256 as padding function. The firmware was designed and implemented with the intention of meeting the signing requirements under FIPS 140-2.

All HGST firmware packages will be signed, but only encryption enabled drives will verify the signature. If the signature cannot be successfully verified on encryption drives, the firmware cannot be downloaded onto the HGST encryption drives. Failures to authenticate the firmware image will result in **Check Condition with KCO 5/26/9a (FRU 0)**. The act of issuing a firmware download to the drive will result in an implicit close of all open sessions at the security layer.

## 20.6 Ports

The ports capability is an HGST feature which is not a requirement under TCG Enterprise SSC. In order to use the ports capabilities on encryption drives, the user must successfully authenticate. Once a user successfully authenticates, they may change the state of any of the ports at any time during an active session to either the locked or unlocked state. The functionality and definition of these ports is shown below in a table.

The feature does make use of the TCG structures and tables. An additional table, the ports table, has been implemented, and additional entries were made to the Admin SP ACE table and the Admin SP AccessControl Table. The ports table and the modified TCG SSC tables are shown below

**Table 240: Ports Functionality**

Port Name	Description
Firmware Download	<p>This port has 2 valid states: locked and unlocked.</p> <p>On encryption drives, the download port is unlocked initially, LockOnReset is "Null". Code can be downloaded onto the drive after the signature is successfully verified. If the signature cannot be verified successfully, no firmware can be downloaded to the drive. The user can change the state of the firmware download port only after authentication.</p> <p>On non-encryption drives, this port will be set to unlocked at the factory, and the state cannot be changed by the user. Firmware will be downloaded to the non-encryption drive through this port without verification of the signature.</p>
Diagnostics	<p>This port has 2 valid states: locked and unlocked. This port allows HGST access to modify any TCG table or key. In order to open this port both the SID and the Maker authorities need to be authenticated. The purpose of this port is to aid HGST in debugging</p>

**Table 241: Ports Table**

UID	Name	LocOnReset	PortLocked
00 01 00 02 00 01 00 02	Firmware_Dload_Port	Null	FALSE
00 01 00 02 00 01 00 01	Diagnostic_Port	PowerCycle	TRUE

**Table 242: Modified Admin SP ACE Table**

UID	Name	Cmn Name	Boolean Expression	Row Start	Row End	Column Start	Column End
00 00 00 08 00 00 00 01	Anybody	""	00 00 00 09 00 00 00 01	Null	Null	""	""
00 00 00 08 00 00 00 03	Makers	""	00 00 00 09 00 00 00 03	Null	Null	""	""
00 00 00 08 00 00 02 01	SID	""	00 00 00 09 00 00 00 06	Null	Null	""	""
00 00 00 08 00 00 8C 03	SID_SetSelf	""	00 00 00 09 00 00 00 06	Null	Null	"PIN"	"PIN"
00 00 00 08 00 00 8C 04	MSID_Get	""	00 00 00 09 00 00 00 01	Null	Null	"PIN"	"PIN"
00 00 00 08 00 00 8C 05	SID_Set Makers	""	00 00 00 09 00 00 00 06	Null	Null	"Enabled"	"Enabled"
00 00 00 08 00 00 8C 06	SID_Makers_SetDiag	""	00 00 00 09 00 00 00 06 And 00 00 00 09 00 00 00 03	Null	Null	"PortLocked"	"PortLocked"
00 00 00 08 00 00 8C 07	SID_Makers_SetDiag	""	00 00 00 09 00 00 00 06 And 00 00 00 09 00 00 00 03	Null	Null	"PortLocked"	"PortLocked"
00 00 00 08 00 00 8C 08	SID_GetPort	""	00 00 00 09 00 00 00 06	Null	Null	"PortLocked"	"PortLocked"
00 00 00 08 00 00 8C 09	SID_GetPort	""	00 00 00 09 00 00 00 06	Null	Null	"LockOnReset"	"PortLocked"

The last 2 lines of the table are the additional entries required to implement the firmware download port.

**Table 243: Modified Admin SP AccessControl Table**

Row Number	UID	Invoking ID	MethodID	Common Name	ACL	Log	Add ACE ACL	Remove ACE ACL	MethodID
VU	VU	00 00 00 00 00 00 00 01 (ThisSP)	00 00 00 06 00 00 00 0C (Authenticate)	AnybodyAuthenticateAdminSP	00 00 00 08 00 00 00 01 (Anybody)	None	Null	Null	00 00 00 06 00 00 00 0C (Authenticate)
VU	VU	00 00 00 09 00 00 00 00 (Authority table)	00 00 00 06 00 00 00 08 (Next)	Makers-Next-Authority table	00 00 00 08 00 00 00 03 (Makers)	None	Null	Null	00 00 00 08 00 00 00 03 (Makers)
VU	VU	00 00 00 09 00 00 00 01 (Anbody Authority object)	00 00 00 06 00 00 00 06 (Get)	Anyboby-Get-Anbody Authority Object	00 00 00 08 00 00 00 01 (Anybody)	None	Null	Null	00 00 00 08 00 00 00 01 (Anybody)
VU	VU	00 00 00 09 00 00 00 03 (Makers Authority object)	00 00 00 06 00 00 00 06 (Get)	Anyboby-Get-Anbody Authority Object	00 00 00 08 00 00 00 03 (Makers)	None	Null	Null	00 00 00 08 00 00 00 03 (Makers)
VU	VU	00 00 00 09 00 00 00 06 (SID Authority object)	00 00 00 06 00 00 00 06 (Get)	SID-Get-SID Authority Object	00 00 00 08 00 00 02 01 (SID)	None	Null	Null	00 00 00 08 00 00 02 01 (SID)
VU	VU	00 00 00 0B 00 00 00 00 (C_PIN table)	00 00 00 06 00 00 00 08 (Next)	Makers-Next-C_PIN table	00 00 00 08 00 00 00 02 (Makers)	None	Null	Null	00 00 00 08 00 00 00 02 (Makers)
VU	VU	00 00 00 0B 00 00 00 01 (SID C_PIN object)	00 00 00 06 00 00 00 07 (Set)	SID_SetSelf-Set-SID_C_PIN object	00 00 00 08 00 00 8C 03 (SID_SetSelf)	None	Null	Null	00 00 00 08 00 00 02 01 (SID)
VU	VU	00 00 00 0B 00 00 84 02 (MSID C_PIN object)	00 00 00 06 00 00 00 06 (Get)	MSID_Get-Get-MSID C_PIN object	00 00 00 08 00 00 8C 04 (MSID_Get)	None	Null	Null	00 00 00 08 00 00 02 01 (SID)
VU	VU	00 00 00 09 00 00 00 03 (Makers Authority object)	00 00 00 06 00 00 00 07 (Set)	SID_SetMakers-Set-Makers Authority Object	00 00 00 08 00 00 8C 05 (SID_SetMakers)	None	Nul	Nul	00 00 00 08 00 00 02 01 (SID)
VU	VU	00 00 00 00 00 00 00 01 (ThisSP)	00 00 00 06 00 00 06 01 (Random)	Anybody-Random	00 00 00 08 00 00 00 01 (Anybody)	None	Nul	Nul	00 00 00 08 00 00 00 01 (Anybody)
VU	VU	00 01 00 02 00 01 00 02	00 00 00 06 00 00 00 07	SID_Set_Dload	SID_SetPort	None	Nul	Nul	00 00 00 08 00 00 02 01 (SID)
VU	VU	00 01 00 02 00 01 00 02	00 00 00 06 00 00 00 06	SID_GetDload	SID_GetPort	None	Nul	Nul	00 00 00 08 00 00 02 01 (SID)
VU	VU	00 01 00 02 00 01 00 01	00 00 00 06 00 00 00 07	SID_Makers_SetDiag	SID_Makers_SetDiag	None	Nul	Nul	00 00 00 08 00 00 02 01 (SID)
VU	VU	00 01 00 02 00 01 00 02	00 00 00 06 00 00 00 06	SID_Makers_SetDiag	SID_Makers_SetDiag	None	Nul	Nul	00 00 00 08 00 00 02 01 (SID)

The last 2 lines of the table are the additional entries required to implement the firmware download port.

## 21.7 MSID

The MSID is set for each drive at the time of manufacturing to the serial number concatenated 4 times, to create a 32 byte password. Thus, as an example, if the serial number of a drive is abcd1234, the MSID would then be set to abcd1234abcd1234abcd1234abcd1234. In TCG use cases such as “erase” or “repurpose”, this will be the MSID that is restored to the drive.

HGST serial numbers are unique and are generated according to the following general rules:

- Maximum length of the serial number is 8 characters
- Serial numbers do not contain the characters "I" or "O".

## 21.8 Logging

HGST logging functions will not record any sensitive data such as customer plain text data, passwords, encryption keys or wrapping keys.

## 21.9 Number of Sessions

The HGST implementation supports 1 active session at a time. In the case when a session is active and a new session is requested, the drive answers the host with SP\_BUSY. This covers the following 2 scenarios.

- If an SP is in session and an attempt is made to start a second session with the same SP.
- If an SP is in session and an attempt is made to start a second session with a different SP.

## 21.10 Number of Bands

The Enterprise SSC specification calls for support of up to 1024 bands. The HGST implementation supports a maximum of 64 bands.

## 21.11 Number of COMIDs

The HGST Enterprise SSC implementation supports 2 COMIDs, the minimum requirement in the Enterprise SSC specification. Only 1 comid can be in use at any time.

## 21.12 Locked and Unlocked Behavior

### 21.12.1 T10 SCSI commands

The table below describes how basic T10 SCSI commands behave on encryption drives in the locked and unlocked states.



**Table 244: T10 SCSI Commands Behavior Table**

Command	Unlocked	Locked
FORMAT UNIT (04)	OEM	Command can't be executed when locked. Must unlock with MSID or password, before formatting.
INQUIRY (12)	OEM	OEM
LOG SELECT (4C)	OEM	OEM
LOG SENSE (4D)	OEM	OEM-no access to customer data, will get some log information.
MODE SELECT (15)	OEM	OEM
MODE SELECT (55)	OEM	OEM
MODE SENSE (1A)	OEM	OEM
MODE SENSE (5A)	OEM	OEM
PERSISTENT RESERVE IN (5E)	OEM	OEM
PERSISTENT RESERVE IN (5F)	OEM	OEM
PRE-FETCH (34)	OEM	MSID only - limits DRAM accessibility. This is a read function.
READ (6) - (08)	OEM	Ent_A authorized only
READ (10) - (28)	OEM	Ent_A authorized only
READ (12) - (A8)	OEM	Ent_A authorized only
READ (16) - (88)	OEM	Ent_A authorized only
READ (32) - (7F/09)	OEM	Ent_A authorized only
READ BUFFER (3C)	OEM	OEM. Sensitive data cannot be snapshotted from DRAM.
READ CAPACITY (10) - (25)	OEM	OEM
READ CAPACITY (16) (9E/10)	OEM	OEM
READ DEFECT DATA (37)	OEM	OEM
READ DEFECT DATA (B7)	OEM	OEM
READ LONG (3E)	OEM	Ent_A authorized only
REASSIGN BLOCKS (07)	OEM	Command access denied if the effective range is locked.
RECEIVE DIAGNOSTICS RESULTS (1C)	OEM	OEM
RELEASE (17)	OEM	OEM
RELEASE (57)	OEM	OEM
REPORT DEVICE IDENTIFIER (A3/05)	OEM	OEM.
REPORT LUNS (A0)	OEM	OEM.
REPORT SUPPORTED OPERATION CODES (A3/0C)	OEM	OEM.
REPORT SUPPORTED TASK MANAGEMENT FUNCTIONS (A3/0D)	OEM	OEM
REQUEST SENSE (03)	OEM	OEM
RESERVE (16)	OEM	OEM
RESERVE (56)	OEM	OEM
REZERO UNIT (01)	OEM	OEM
SEEK (6) - (0B)	OEM	OEM
SEEK (10) - (2B)	OEM	OEM
SEND DIAGNOSTIC (1D)	OEM	Customer specific.
SET DEVICE IDENTIFIER (A4/06)	OEM	OEM.
START STOP UNIT (1B)	OEM	OEM
SYNCHRONIZE CACHE (10) - (35)	OEM	OEM
SYNCHRONIZE CACHE (16) - (91)	OEM	OEM
TEST UNIT READY (00)	OEM	OEM
VERIFY (2F)	OEM	Command access denied if the effective range is locked.

VERIFY (12) - (AF)	OEM	Command access denied if the effective range is locked.
VERIFY (16) - (8F)	OEM	Command access denied if the effective range is locked.
VERIFY (32) - (7F/0A)	OEM	Command access denied if the effective range is locked.
WRITE (6) - (0A)	OEM	Command access denied if the effective range is locked.
WRITE (10) - (2A)	OEM	Command access denied if the effective range is locked.
WRITE (12) - (AA)	OEM	Command access denied if the effective range is locked.
WRITE (16) - (8A)	OEM	Command access denied if the effective range is locked.
WRITE (32) - (7F/0B)	OEM	Command access denied if the effective range is locked.
WRITE AND VERIFY (10) - (2E)	OEM	Command access denied if the effective range is locked.
WRITE AND VERIFY (12) - (AE)	OEM	Command access denied if the effective range is locked.
WRITE AND VERIFY (16) - (8E)	OEM	Command access denied if the effective range is locked.
WRITE AND VERIFY (32) - (7F/0C)	OEM	Command access denied if the effective range is locked.
WRITE BUFFER (3B) (T10)	OEM (write DRAM onto drive)	OEM.
WRITE BUFFER (3B) (For FW download)	FW is signed and downloaded.	OEM. The write buffer command only functions to write to the buffer.
WRITE LONG (3F)	OEM	Per TCG and T10 specification. Ent_A authorized only.
WRITE SAME (41)	OEM	Ent_A authorized only
WRITE SAME (16) - (93)	OEM	Ent_A authorized only
WRITE SAME (32) - (7F/0D)	OEM	Ent_A authorized only
SECURITY_IN	OEM	Per TCG spec. Contains TCG payload.
SECURITY_OUT	OEM	Per TCG spec. Contains TCG payload.

## 21.12.2 TCG SSC Commands

The table below describes how the required TCG Enterprise SSC commands behave on encryption drives in the locked and unlocked states. The TCG SSC requires the implementation of the Base, Admin, Locking, and Crypto Templates. As noted, the Crypto template was not implemented. In addition the SSC does not require any Admin Template tables or methods, so

they are not mentioned in the table below.

**Table 245: TCG Enterprise SSC Commands Behavior**

<b>Command</b>	<b>Description</b>	<b>unlocked</b>	<b>Locked</b>
<b>Session Management</b>	There are two types of sessions: 1) Read-Only session 2) Read-Write session. The SSC requires us to support Read-Write sessions. Read-Only session is not allowed. A session is always initiated by the host. See the “Write” parameter in the StartSession method description @ TCG Core 5.2.3.1, and see SSC requirement in SSC 6.2.1.2.		
Properties	Returns session properties to host.	N/A	N/A
StartSession	Start a session	N/A	N/A
SycSession	Response to say session successfully started.	N/A	N/A
CloseSession	End (Close) a session	N/A	N/A

<b>Command</b>	<b>Description</b>	<b>unlocked</b>	<b>Locked</b>
<b>Discovery</b>	<b>Allows the host to discover a TCG drive, its properties, and table values.</b>		
Level 0	Discovery request sent by host as IF-RCV command. Security Protocol = 0x01, COMID=0x0001	N/A	N/A
Level 1	Request basic TPER capabilities via properties using host messaging.	Uses properties method.	Uses properties method.
Level 2	TCG methods retrieve table cell values.	See methods below.	See methods below.

<b>Command</b>	<b>Description</b>	<b>unlocked</b>	<b>Locked</b>
<b>Cryptographic Template</b>	<b>Random function is only function required under SSC</b>		
Random	This is the only required method in the crypto template for SSC. It is a random number generator in software.	N/A - Not related to bands/data on drive. Authentication required.	N/A - Not related to bands/data on drive. Authentication required.

Command	Description	unlocked	Locked
Base Template	Mandatory		
Set	Sets a value in a table	N/A - table operations. Not related to bands/data on drive.	N/A - table operations. Not related to bands/data on drive.
Get	Gets (reads) a value in a table	N/A - table operations. Not related to bands/data on drive.	N/A - table operations. Not related to bands/data on drive.
ParamCheck LRC	TPer implements param check LRC (longitudinal Redundancy Check) on get/set method calls on PIN value	N/A	N/A
Next	Iterates over all the rows of a table. Method requires user to specify "where" (row in table) and a "count". If where not specified, 1st row in table is used. For count not specified, default is number of last row in table. Returns 0 or more row number/uidref pairs currently in use in table, per parameters specified.	N/A - table operations. Not related to bands/data on drive.	N/A - table operations. Not related to bands/data on drive.
Authenticate	Authenticate an authority within a session (session must have successfully begun).	Must be authorized.	Must be authorized.
GatACL	Returns contents of access controls association's ACL stored in Method Table. The result is a list of uidrefs to ACE objects.	N/A - table operations. Not to do with bands/data on drive.	N/A - table operations. Not related to bands/data on drive.

Command	Description	unlocked	Locked
Locking Template	Mandatory		
Erase	Cryptographically erases user data in a specified LBA range and resets the access control (locking) of that LBA	Can erase if authorized.	Generates error.

## 21.13 Error Codes

All error codes are compliant with the TCG Core specification and SIIF, except in the following case:

- The maximum sessions allowed at any single time is 1. When a session is active and a new session is requested, the drive answers the host with SP\_BUSY, instead of NO\_SESSIONS\_AVAILABLE.

## 20.14 Customer Specific Requirements

This specification does not cover customer-specific requirements. Customer-specific requirements are submitted by the customer to HGST in the form of a customer-specification document.

# 22.0 SCSI Sense Data

## 22.1 SCSI Sense Data Format Introduction

Sense data is returned as CHECK CONDITION status and as parameter data in response to the REQUEST SENSE command. The sense data returned by the drive can be in either fixed or descriptor format

### 22.1.1 Sense Data Format

Format of sense data returned as a CHECK\_CONDITION\_STATUS is based on the value of the D\_SENSE bit in the Control mode page (See section 18.10.9). The REQUEST SENSE command may be used to request either the fixed format sense data or the descriptor format sense data (See section 18.36).

### 22.1.2 Sense Data Length

Length of the sense data returned as part of CHECK\_CONDITION status is determined by the sense data format:

- a) Length of fixed format sense data is always 32 byte.
- b) Length of descriptor format sense data is 60 byte (Generic Configuration)

For REQUEST SENSE command, length of the sense data is the number of bytes in the command's Allocation Length or the sense data length described above, whichever is less.

### 22.1.3 Sense Data Response Code

The first byte of all sense data contains the RESPONSE CODE field that indicates the error type and format of the sense data. Table 246: , "Sense data response codes." shows the RESPONSE CODE values which may be returned by the drive

**Table 246: Sense data response codes.**

Response Code	Error Type	Sense Data Format
70h	Current	Fixed
71h	Deferred	Fixed
72h	Current	Descriptor
73h	Deferred	Descriptor

**Current Error:**This indicates an error for the current command.

**Deferred Error:**This indicates that the error is for a previous command that has already returned a good status. Such commands are associated with the immediate bit or write caching. Format unit (04h) command is an example of a command that may return a deferred error.

## 22.2 Fixed Format Sense Data

Table 247 shows the format of fixed format of the sense data returned by the drive.

**Table 247: Fixed Format of Sense Data.**

Byte	Bit							
	7	6	5	4	3	2	1	0
0	Valid	Response Code (70h or 71h)						
1	RSVD = 0							
2	0	ILI	0	Sense Key				
3-6	(MSB)	Information Bytes						(LSB)
7	Additional Sense Length							
8-11	(MSB)	Command Specific Information						(LSB)
12	Additional Sense Code							
13	Additional Sense Code Qualifier							
14	FRU = 0							
15	SKSV	Sense-Key Specific Bits						
16-17	Sense-Key Specific Bytes							
18-19	Reserved = 0							
20-23	Vendor unique Error information							
24-29	Command Specific Information							
30-31	Reserved = 0							

### 22.2.1 Valid (Bit 7 of byte 0)

- 0 The Information Bytes (byte 3 through 6) are not defined.
- 1 The Information Bytes (byte 3 through 6) contain a valid logical block address.

### 22.2.2 Response Code (Bit 6 - 0 of byte 0)

- 70h Current Error. See section 22.1.3 for more details.
- 71h Deferred Error. See section 22.1.3 for more details.

### 22.2.3 ILI: Incorrect Length Indicator (Bit 5 of byte 2)

The ILI bit is valid for the Read Long (3Eh) command and Write Long (3Fh) command only. ILI set to one and Valid Bit set to one indicates that the requested logical block length does not match the logical block length of the data on the medium for a Read Long or Write Long command. The Information field contains residue information about the error. ILI set to zero indicates there is no incorrect length condition.

- 0** No Incorrect Length condition.
- 1** Incorrect Length Indicated.

Valid	ILI	Command = Read Long or Write Long	Description
x	0	x	No incorrect length condition
1	1	yes	Requested Logical block Length does not match the logical block length of the data on the disk

### 22.2.4 Sense Key (Bit 3 - 0 of byte 2)

The sense key provides generic categories in which error and exception conditions can be reported. Initiators would typically use sense keys for high level error recovery procedures.

- 0h No Sense**  
There is no sense key information to be reported for the logical unit.
- 1h Recovered Error**  
The last command completed successfully with some recovery action performed by the drive. More detailed information is available in the Additional Sense Code and Additional Sense Code Qualifier.
- 2h Not Ready**  
The logical unit addressed cannot be addressed. More detailed information is available in the Additional Sense Code and Additional Sense Code Qualifier.
- 3h Medium Error**  
The command terminated with an unrecoverable error condition caused by a flaw in the media or an error in the recorded data. More detailed information is contained in the Additional Sense Code and Additional Sense Code Qualifier.
- 4h Hardware Error**  
The drive detected an unrecoverable hardware error while performing a command or during a diagnostic test. More detailed information is contained in the Additional Sense Code and Additional Sense Code Qualifier.
- 5h Illegal Request**  
There was an illegal parameter in the command descriptor block or additional parameter supplied as data. If an invalid parameter is found in the CDB, then the command is terminated without altering the medium. If an invalid parameter is found in parameters supplied as data, then the drive might have altered the medium.
- 6h Unit Attention**  
Indicates that the drive entered in the 'Unit Attention Condition'. (See Section 20.1.5)
- 7h Data Protect**
- 8h Not used**
- 9h Vendor Specific**

- Ah** Not used
- Bh** **Aborted command**  
The drive aborted the command.
- Ch-Dh** **Not Implemented**
- Eh** **Miscompare**
- Fh** **Reserved**

### 22.2.5 Information Bytes (Byte 3 through 6)

This field is only valid when VALID bit is one.

- ILI = 0: This field contains the unsigned LBA associated with the sense key. The LBA reported will be within the LBA range of the command as defined in the CDB.

**Note:** An LBA other than the command LBA may be reported on the Reassign Block (07h) command.

**Note:** When the value that need to be stored in the Information field is greater than 0xFFFFFFFF (e.g. an LBA greater than 2TiB) the VALID bit will always be set to 0. To retrieve such information in such cases, the drive must be configured to return sense data in descriptor format. See section 18.10.9 for details

- ILI = 1: This field contains the difference (residue) of the requested length in bytes. Negative values are indicated by two's complement notation.

Valid	ILI	Description
0	x	0x00000000 - (not used/invalid)
1	0	LBA
1	1	Residue of the requested length in bytes

### 22.2.6 Additional Sense Length (Byte 7)

Indicates the remaining number of bytes in the sense data. (It is always set to 18h.)

### 22.2.7 Command Specific Information (Byte 8 through 11)

This field is unused and will be set to zero.

### 22.2.8 Additional Sense Code/Qualifier (Byte 12 and 13)

The following table shows the description of the combination of Sense Key / Sense Code / Qualifier.

Valid Sense Key, Code, Qualifier Combinations Used by the Drive.			
Key	Code	Qual	Description
			Sense Key = No Sense
0	00	00	No Additional Sense Information
			(00 00) No Error.



<b>Sense Key = No Sense</b>			
<b>0</b>	<b>5E</b>	<b>01</b>	<b>Idle_A Condition activated by timer</b>
			1831 Power Save: Idle_A by timer
<b>0</b>	<b>5E</b>	<b>02</b>	<b>Standby_Z Condition activated by timer</b>
			1834 Power Save: Standby_Z by timer
<b>0</b>	<b>5E</b>	<b>03</b>	<b>Idle_A Condition activated by Command</b>
			1835 Power Save: Idle_A by Command
<b>0</b>	<b>5E</b>	<b>04</b>	<b>Standby_Z Condition activated by Command</b>
			1838 Power Save: Standby_Z by Command
<b>0</b>	<b>5E</b>	<b>05</b>	<b>Idle_B Condition activated by timer</b>
			1832 Power Save: Idle_B by timer
<b>0</b>	<b>5E</b>	<b>06</b>	<b>Idle_B Condition activated by Command</b>
			1836 Power Save: Idle_B by Command
<b>0</b>	<b>5E</b>	<b>07</b>	<b>Idle_C Condition activated by timer</b>
			1833 Power Save: Idle_C by timer
<b>0</b>	<b>5E</b>	<b>08</b>	<b>Idle_C Condition activated by Command</b>
			1837 Power Save: Idle_C by Command
<b>0</b>	<b>5E</b>	<b>09</b>	<b>Standby_Y Condition activated by timer</b>
			1839 Power Save: Standby_Y by timer
<b>0</b>	<b>5E</b>	<b>0a</b>	<b>Standby_Y Condition activated by Command</b>
			183A Power Save: Standby_Y by Command
<b>Sense Key = Recovered Error</b>			
<b>1</b>	<b>02</b>	<b>00</b>	<b>No Seek Complete</b>
			141B Servo: Recovered No seek complete
			141D Servo: Recovered Seek timeout
			141F Servo: Recovered Seek error
			142B Servo: Recovered RRO Calibration timeout
<b>1</b>	<b>03</b>	<b>00</b>	<b>Peripheral Device Write Fault</b>
			1737 Recovered post write abort

			1739 Servo Recovered Post PES check write abort
			17D6 Servo Recovered read/write abort offtrack
			17D8 Servo Recovered read/write abort rro field missing
			17DA Servo Recovered read/write abort rro field misread
			17DC Servo Recovered read/write abort rro field missing
			17DE Servo Recovered read/write abort seek timeout
			17E0 Servo Recovered read/write abort estimator error
			17E2 Servo Recovered read/write abort predictor error
			17E4 Servo Recovered read/write abort PES error
			17E6 Servo Recovered read/write abort seek start error
			17E8 Servo Recovered read/write abort PES reset error
			17EA Servo Recovered read/write abort abort WCS other error
			17EC Servo Recovered read/write abort WCS other error
			17EE Servo Recovered read/write abort hard reset
			17F0 Servo Recovered read/write abort RV sensor error
			17F2 Servo Recovered read/write abort RV sensor error
			17F4 Servo Recovered read/write abort SHARP other error
			17F6 Servo Recovered read/write abort SHARP exception error
			17F8 Servo Recovered read/write abort SVGA limit error
			17FA Servo Recovered read/write abort gray code error
			17FC Servo Recovered read/write abort burst error
			17FE Servo Recovered read/write abort no STM error
<b>1</b>	<b>09</b>	<b>00</b>	<b>Track Following Error</b>
			1421 Servo: Recovered track following error
			1423 Servo: Recovered track follow timeout
<b>1</b>	<b>0B</b>	<b>01</b>	<b>Temperature Warning Error</b>
			2A02 Temperature Warning
<b>1</b>	<b>0B</b>	<b>03</b>	<b>Background Selftest Failure Warning</b>
			2A03 Background selftest failure warning

<b>1</b>	<b>0B</b>	<b>04</b>	<b>Background Pre-Scan Failure Warning</b>
			2A04 Background pre-scan failure warning
<b>0</b>	<b>0B</b>	<b>05</b>	<b>Background Media Scan Failure Warning</b>
			2A05 Background media scan failure warning
<b>1</b>	<b>0C</b>	<b>01</b>	<b>Recovered Write Error with Auto Reallocation - Auto Reallocated</b>
			1703 Auto-reallocated due to write error
<b>1</b>	<b>0C</b>	<b>03</b>	<b>Recovered Write Error - Recommend Reassignment</b>
			1704 Recommend reassign due to write error
<b>1</b>	<b>15</b>	<b>00</b>	<b>Random Positioning Error</b>
			1714 Recovered sector overflow
			173D Recovered sector miss
			1770 Recovered SID timeout
			17B2 Recovered abort window error
<b>1</b>	<b>16</b>	<b>00</b>	<b>Data Synchronization Mark Error</b>
			1735 Recovered data address mark error HDC
			173B Recovered data address mark error Channel
			1764 Correctable media error (embedded DAM only)
			17A9 Recovered read overrun
<b>1</b>	<b>16</b>	<b>01</b>	<b>Data Sync Error - Data Rewritten</b>
			E70E Recovered Data Address Mark error - rewritten
<b>1</b>	<b>16</b>	<b>02</b>	<b>Data Sync Error - Recommend Rewrite</b>
			E70F Recovered Data Address Mark error - recommend rewrite
<b>1</b>	<b>16</b>	<b>03</b>	<b>Data Sync Error - Auto Reallocated</b>
			D710 Recovered Data Address Mark error - reassigned
<b>1</b>	<b>16</b>	<b>04</b>	<b>Data Sync Error - Recommend Reassignment</b>
			E711 Recovered Data Address Mark error - recommend reassign
<b>1</b>	<b>17</b>	<b>01</b>	<b>Recovered Data with Retries</b>
			1722 Recovered small thermal asperity
			172C Recovered media error

			172E Recovered media error (off-line correction discarded)
			1766 Recovered Media LBA MEDC error
			176C Media: Soft MEDC Correctable
			1782 Media: Force Soft Error
			1784 Media: Soft CHN Sect Marginal
<b>1</b>	<b>17</b>	<b>06</b>	<b>Recovered Data - Data Auto-Reallocated</b>
			D705 Media error with correction - reassigned
			D72B Recovered thermal asperity - reassigned
<b>1</b>	<b>17</b>	<b>07</b>	<b>Recovered Data - Recommend Reassignment</b>
			E706 Media error with correction - recommend reassign
			E72A Recovered thermal asperity - recommend reassign
<b>1</b>	<b>17</b>	<b>08</b>	<b>Recovered Data - Recommend Rewrite</b>
			E707 Media error with correction - recommend rewrite
			E729 Recovered thermal asperity - recommend rewrite
<b>1</b>	<b>17</b>	<b>09</b>	<b>Recovered Data- Data Rewritten</b>
			E708 Media error with correction - rewritten
			E728 Recovered thermal asperity - rewritten
<b>1</b>	<b>1C</b>	<b>00</b>	<b>Defect List Format Not Supported</b>
			1746 Defect list format not supported
<b>1</b>	<b>1C</b>	<b>01</b>	<b>Primary Defect List Not Found. Requested Format Not Supported</b>
			1747 Primary defect list not found (Read Defect Data only)
<b>1</b>	<b>1C</b>	<b>02</b>	<b>Grown Defect List Not Found. Requested Format Not Supported</b>
			1748 Grown defect list not found (Read Defect Data only)
<b>1</b>	<b>1F</b>	<b>00</b>	<b>Partial Defect List Transfer</b>
			1749 Partial defect list transferred (Defect list longer than 64KB, 64 KB of data returned - Read Defect Data only)
<b>1</b>	<b>44</b>	<b>00</b>	<b>Internal Target Failure</b>
			F123 Invalid request to enter sleep mode
			F128 DRAM test in progress
			F129 DRAM test complete

			F132 GEM FH track read error
			1201 Error in UEC class
			1202 Error in UEC cause
			1303 Motor: Recovered Open Loop Commutation failure
			1305 Motor: Recovered No feedback detected
			1307 Motor: Recovered Settle timeout
			130D Motor: Recovered Speed error
			1401 Servo: Recovered Requested rezero head does not exist
			1403 Servo: Recovered Back EMF movement in progress
			1405 Servo: Recovered Back EMF timeout error
			1407 Servo: Recovered ADC conversion timeout
			1409 Servo: Recovered Load/unload calibration error
			140B Servo: Recovered Invalid 5 volts
			140D Servo: Recovered Invalid 12 volts
			140F Servo: Recovered Invalid harmonic requested
			1411 Servo: Recovered Gain BEMF Calibration error
			1413 Servo: Recovered VOFF BEMF calibration error
			1415 Servo: Recovered Invalid temperature
			1417 Servo: Recovered Truncated rezero
			1419 Servo: Recovered Heads not loaded
			1425 Servo: Recovered KT Seek out of range
			1427 Servo: Recovered DAC Offset calibration error
			1429 Servo: Recovered Load speed error
			142D Servo: Recovered ADC Calibration error
			142F Servo: Recovered ADC Offset error
			1431 Servo: Recovered ADC Limit error
			1433 Servo: Recovered Balancer Resistance error
			1435 Servo: Recovered Balancer Resistance Limit error
			1437 Servo: Recovered First Cylinder error

			1439 Servo: Recovered Valid Cylinder error
			143B Servo: Recovered ADC Saturation error
			143D Servo: Recovered Latch Break timeout
			143F Servo: Recovered MR Resistance out of range error
			1441 Servo: Recovered VCM Retract error
			1443 Servo: Recovered Load Retry error
			1445 Servo: Recovered DFT Sharp error
			1447 Servo: Recovered Load/Unload state error
			144B Servo: Recovered Measure GMR Timeout
			144D Servo: Recovered Coil Resistance Measurement Failure
			145F Servo: Recovered WCS Hang Error
			1461 Servo: Recovered DFT Timeout Error
			1463 Servo: Recovered SDM Timeout Error
			1465 Servo: Recovered Velocity Error
			146F Servo: Recovered VCM Free Speed Error
			1471 Servo: Recovered Emergency Brake Timeout Error
			1473 Servo: Recovered Excessive Current Error
			1475 Servo: Recovered Excessive Velocity Error
			1477 Servo: Soft RROF SDM Timeout Error
			1479 Servo: Soft Milli CAL Error
			1606 Recovered AE last data read error
			1616 Recovered channel error
			1618 Recovered AE thermal asperity
			161A Recovered AE open MR element error
			161C Recovered AE IC over temperature error
			161E Recovered AE IP clock count error
			1620 Recovered AE write data BLS error
			1622 Recovered AE high MR current error
			1624 Recovered AE invalid head address error

			1626 Recovered AE power supply error
			162A Recovered AE write transition error
			162C Recovered AE no write head current error
			162E Recovered Channel Pre-TA error
			1634 Recovered AE Short write read head error
			1636 Recovered AE Short write head error
			1638 Recovered AE Non-selected write head error
			163C Recovered AE IH open short error
			163E Recovered AE IH delay error
			1640 Recovered Channel coarse tune timeout error
			1642 Recovered AE Readback error
			1644 Recovered AE XSDEN Low during write error
			1646 Recovered AE Write Gate during Idle Fault
			1648 Recovered Channel Reset Flag Error
			164A Recovered Channel Split Fault Error
			164C Recovered Channel Sector Size Fault Error
			164E Recovered Channel Last Split Fault Error
			1650 Recovered Channel Servo Servo Overlap Error
			1652 Recovered Channel Read Gate Fault Error
			1656 Recovered Channel No Write Clock Error
			1658 Recovered Channel No NRZ Clock Error
			165A Recovered Channel Cal Block Fault Error
			165C Recovered Channel Mode Overlap Fault Error
			165E Recovered Channel Preamble Fault Error
			1660 Recovered Channel WPLO Error
			1662 Recovered Channel Write Gate Overlap Fault Error
			1664 Recovered Channel Write Gate Fault Error
			1666 Recovered Channel Buffer Overflow Write Error
			1668 Recovered Channel Buffer Overflow Write Error

			166A Recovered Channel Write Parity Error
			166C Recovered Channel Buffer Overflow Write Error
			166E Recovered Channel Buffer Underflow Write Error
			1670 Recovered Channel RPLO Late Error
			1672 Recovered Channel Bit Count Late Error
			1674 Soft Chn Prea Cnt Fault Error
			1676 Recovered Channel Pfault Read Error
			1678 Recovered Channel Pfault Write Error
			167A Recovered Channel Last Data Fault Error
			167C Recovered Channel WRPO Fault Error
			167E Soft Forced Chan Fault Error
			1680 Recovered Channel PLLFloor Error
			1682 Recovered Channel Losslock Error
			1684 Recovered Channel VGA Floor Error
			1686 Recovered Channel Buffer EVGA Floor Error
			1688 Recovered Channel TA Detector Error
			168C Recovered Channel ZGR Flag Error
			168E Recovered Channel DPLL Freq Flag Error
			1694 Recovered Channel Flaw Sig Sync Error
			1696 Recovered Channel ACQ Flag Error
			1698 Recovered Channel No Clock Error
			169A Recovered Channel PLL Losslock Error
			169C Recovered AE TFC Short Error
			169E Recovered AE MR Element Short Error
			1654 Recovered Channel RWBI Out Fault Error
			1712 Recovered MEDC error
			1716 Recovered write overrun
			171A Recovered MEDC overrun
			171C Recovered DRAM CRC error



			171E Recovered ID Parity error
			1731 Recovered write fault
			1759 Unknown recovered error
			176A Recovered No NRZ clock error
			176E Media: Soft Chan Rdy Error
			1778 Media: Soft LBA FIFO Error
			1786 Recovered Soft LLI Underrun
			1792 Recovered MEDC Write Data Not Ready Error
			1794 Recovered DMA Timeout Error
			1798 Recovered ID not found error
			179C Recovered Channel Read Timeout Error
			17B4 Recovered Shock sensor error
			17C2 Recovered Read CRC error
			17C4 Recovered DRAM ECC error
			17C6 Recovered DRAM ECC LBA error
<b>1</b>	<b>44</b>	<b>0B</b>	<b>Vendor Unique - Internal Target Failure</b>
			1313 Motor: Recovered Inductive Sense measurement timeout
			1315 Motor: Recovered Spin Sense speed error
			1317 Motor: Recovered Spin Sense timeout
			1319 Motor: Recovered Target speed error
			131F Motor: Recovered System clock watchdog error
			1349 Motor: Soft Predriver Fault
			134B Motor: Soft Predriver Fault
			134D Motor: Soft Predriver Fault
			134F Motor: Soft Predriver Fault
			1351 Motor: Soft Predriver Fault
			1353 Motor: Soft Predriver Fault
			1355 Motor: Soft Predriver Fault
			1357 Motor: Soft Predriver Fault

<b>1</b>	<b>44</b>	<b>F9</b>	<b>Vendor Unique - Internal Target Failure</b>
			144F Servo: Recovered SHARP Parity Error
			1451 Servo: Recovered SHARP Parity Rate Error
			1453 Servo: Recovered SHARP Decode Error
			1455 Servo: Recovered SHARP Decode Rate Error
			1457 Servo: Recovered SHARP Timeout Error
			1459 Servo: Recovered SHARP Timeout Rate Error
			145B Servo: Recovered SHARP Other Error
			145D Servo: Recovered SHARP Other Rate Error
<b>1</b>	<b>5D</b>	<b>21</b>	<b>Predictive Failure Analysis – SMART Milliactuator Error</b>
			2A21 SMART: Milliactuator Err (recovered sense)
<b>1</b>	<b>5D</b>	<b>22</b>	<b>Predictive Failure Analysis – SMART Over Temperature Reached</b>
			2A22 SMART: Extreme over-temperature reached (unrecovered sense)
<b>1</b>	<b>5D</b>	<b>50</b>	<b>Predictive Failure Analysis – SMART Load/Unload Cycle Threshold Reached</b>
			2A50 SMART: Load/unload cycle count threshold reached
<b>1</b>	<b>5D</b>	<b>5B</b>	<b>Predictive Failure Analysis – SMART Spin-up Retry Count Threshold Reached</b>
			2A5B SMART: Spin-up retry count threshold reached
<b>1</b>	<b>5D</b>	<b>62</b>	<b>Predictive Failure Analysis – SMART Read/Write Error Rate Threshold Reached</b>
			2A32 SMART: Read error rate threshold reached
			2A4A SMART: Write error rate threshold reached
<b>1</b>	<b>5D</b>	<b>63</b>	<b>Predictive Failure Analysis – SMART Seek Error Rate Threshold Reached</b>
			2A43 SMART: Seek error rate threshold reached
<b>1</b>	<b>5D</b>	<b>64</b>	<b>Predictive Failure Analysis – SMART Available Spare Threshold Reached</b>
			2A14 SMART: Available Spare sector threshold reached
<b>1</b>	<b>5D</b>	<b>66</b>	<b>Predictive Failure Analysis – SMART Spin Up Time Threshold Reached</b>
			2A56 SMART: Spin-up time threshold reached
<b>1</b>	<b>5D</b>	<b>FF</b>	<b>Predictive Failure Analysis - SMART Test Warning Threshold Reached</b>

			2AFF SMART: Test warning threshold reached
<b>1</b>	<b>81</b>	<b>00</b>	<b>Vendor Unique - Internal Logic Error</b>
			1601 Channel/AE internal logic error
			1718 Recovered Abort immediate error
			<b>Sense Key = Not Ready</b>
<b>2</b>	<b>04</b>	<b>00</b>	<b>Logical Unit Not Ready - Start Spindle Motor Fail</b>
			F501 Logical unit not ready
<b>2</b>	<b>04</b>	<b>01</b>	<b>Logical Unit Is In The Process of Becoming Ready</b>
			F502 Logical unit becoming ready
<b>2</b>	<b>04</b>	<b>02</b>	<b>Logical Unit Not Ready, initializing command required</b>
			F124 Bring-up error
			F503 Logical unit not ready - initializing command required
<b>2</b>	<b>04</b>	<b>03</b>	<b>Logical Unit Not Ready, Manual Intervention Required</b>
			F572 Not ready - manual intervention required
<b>2</b>	<b>04</b>	<b>04</b>	<b>Logical Unit Not Ready, Format In Progress</b>
			F504 Not ready - format in progress
<b>2</b>	<b>04</b>	<b>09</b>	<b>Not Ready - Self-test In Progress</b>
			F505 Not ready - self-test in progress
<b>2</b>	<b>04</b>	<b>11</b>	<b>Not Ready - Notify (Enable Spin-up) Required</b>
			F553 Not ready - Notify (Enable Spin-up) required (SAS only)
<b>2</b>	<b>04</b>	<b>F0</b>	<b>Vendor Unique - Logical Unit Not Ready</b>
			F133 BATS error: Vendor ID mismatch
<b>2</b>	<b>31</b>	<b>00</b>	<b>Medium Format Corrupted - Reassign Failed</b>
			F506 Reassign failed
<b>2</b>	<b>31</b>	<b>01</b>	<b>Format Command Failed</b>
			F507 Format failed
			<b>Sense Key = Medium Error</b>
<b>3</b>	<b>03</b>	<b>00</b>	<b>Medium Error - Write Fault</b>
			F738 Unrecovered post write abort

			F73A Unrecovered Post PES check write abort
			F7E1 Servo Unrecovered read/write abort estimator error
			F7E3 Servo Unrecovered read/write abort predictor error
			F7E5 Servo Unrecovered read/write abort PES error
			F7E7 Servo Unrecovered read/write abort seek start error
			F7E9 Servo Unrecovered read/write abort PES reset error
			F7EB Servo Unrecovered read/write abort SID unlock error
			F7ED Servo Unrecovered read/write abort WCS other error
			F7EF Servo Unrecovered read/write abort hard reset
			F7F1 Servo Unrecovered read/write abort RV sensor error
			F7F3 Servo Unrecovered read/write abort RV sensor error
			F7F5 Servo Unrecovered read/write abort SHARP other error
			F7F7 Servo Unrecovered read/write abort SHARP exception error
			F7F9 Servo Unrecovered read/write abort SVGA limit error
			F7FB Servo Unrecovered read/write abort gray code error
			F7FD Servo Unrecovered read/write abort burst error
			F7FF Servo Unrecovered read/write abort no STM error
<b>3</b>	<b>10</b>	<b>00</b>	<b>Unrecovered Read Error</b>
			F7B9 Unrecovered Reference tag error
			F7BB Unrecovered Application tag error
			F7BD Unrecovered Channel write synthesis unlock error
<b>3</b>	<b>11</b>	<b>00</b>	<b>Unrecovered Read Error</b>
			F702 Too many notches
			F723 Unrecovered small thermal asperity
			F72D Unrecovered media error
			F72F Unrecovered media error (off-line correction discarded)
			1730 Recommend TAR Error
			F751 Alternat Track Table Full
			F753 G-list full (Format command)

			F754 G-list full (2) (Format command)
			F755 Pointer repeat size error
			F756 DST slot size error
			F757 P-list full
			F758 Spare list full
			F767 Unrecovered Media LBA MEDC error
			F76D Media: Hard MEDC Uncorrectable
			F783 Media: Hard Force Soft Error
			F785 Media: Hard CHN Sect Marginal
			F7CD LBA Encryption Error
			F7CE Unrecovered Media Offline Already TAR error
<b>3</b>	<b>11</b>	<b>14</b>	<b>Unrecovered LBA write uncorrectable error</b>
			F7CC Unrecovered LBA write uncorrectable error
<b>3</b>	<b>15</b>	<b>00</b>	<b>Random Positioning Error</b>
			F715 Unrecovered sector overflow
			F73E Unrecovered sector miss
			F771 Unrecovered SID timeout
			F7B3 Unrecovered abort window error
<b>3</b>	<b>16</b>	<b>00</b>	<b>Data Synchronization Mark Error</b>
			F736 Unrecovered data address mark error Channel
			F73C Unrecovered data address mark error HDC
			F765 Uncorrectable media error (embedded DAM only)
			F7AA Unrecovered read overrun
			F7A8 Unrecovered marginal data address mark error Channel
<b>3</b>	<b>19</b>	<b>02</b>	<b>Defect List Error in Primary List</b>
			F74B Primary defect list error
<b>3</b>	<b>19</b>	<b>03</b>	<b>Defect List Error in Grown List</b>
			F74C Grown defect list error
<b>3</b>	<b>31</b>	<b>00</b>	<b>Medium Format Corrupted Reassign Failed</b>

			F701 Format corrupted
<b>3</b>	<b>81</b>	<b>00</b>	<b>Vendor Unique - Internal Logic Error</b>
			F719 Recovered Abort immediate error
			F75B Too many sectors
			<b>Sense Key = Hardware Error</b>
<b>4</b>	<b>02</b>	<b>00</b>	<b>No Seek Complete</b>
			F41C Servo: Unrecovered No seek complete
			F41E Servo: Unrecovered Seek timeout
			F420 Servo: Unrecovered Seek error
			F42C Servo: Unrecovered RRO Calibration timeout
<b>4</b>	<b>09</b>	<b>00</b>	<b>Track Following Error</b>
			F422 Servo: Unrecovered track following error
			F424 Servo: Unrecovered track follow timeout
<b>4</b>	<b>31</b>	<b>00</b>	<b>Medium Format Corrupted - Reassign Failed</b>
			F204 Reassign reserved area media error
<b>4</b>	<b>32</b>	<b>00</b>	<b>No Defect Spare Location Available</b>
			F205 G-list full - can't reassign any more sectors
			F206 No spares available
<b>4</b>	<b>35</b>	<b>00</b>	<b>Enclosure Services Failure</b>
			F539 ESI: unspecified failure (FC-AL only)
<b>4</b>	<b>35</b>	<b>01</b>	<b>Enclosure Services Failure - Unsupported Enclosure Function</b>
			F53A ESI: unsupported function (FC-AL only)
<b>4</b>	<b>35</b>	<b>02</b>	<b>Enclosure Services Failure - Enclosure Services Unavailable</b>
			F53B ESI: enclosure unavailable (FC-AL only)
<b>4</b>	<b>35</b>	<b>03</b>	<b>Enclosure Services Failure - Enclosure Services Transfer Failure</b>
			F556 ESI: transfer failed - write ack
			F557 ESI: transfer failed - read ack
			F558 ESI: transfer failed - write ready
			F559 ESI: transfer failed - read ready

			F55E ESI: transfer failed - EDV
			F579 ESI: Transfer Checksum Error
			F57A ESI: Transfer Checksum Ready Timeout
<b>4</b>	<b>35</b>	<b>04</b>	<b>Enclosure Services Failure - Enclosure Services Refused</b>
			F55A ESI: transfer refused - write ack
			F55B ESI: transfer refused - read ack
			F55C ESI: transfer refused - write ready
			F55D ESI: transfer refused - read ready
<b>4</b>	<b>35</b>	<b>80</b>	<b>Enclosure Services Failure</b>
			F53C ESI: SES Timeout
<b>4</b>	<b>3E</b>	<b>03</b>	<b>Self-test Failed</b>
			F75D Self-test failed
<b>4</b>	<b>40</b>	<b>80</b>	<b>Diagnostic Failure</b>
			F101 BATS error: Reserved Area - Invalid request
			F102 BATS error: Reserved Area - Broken
			F103 BATS error: Reserved Area - Invalid version
			F104 BATS error: Reserved Area - Invalid checksum
			F105 BATS error: Reserved Area - Invalid eyecatcher
			F106 BATS error: Reserved Area - Invalid main header checksum
			F107 BATS error: Reserved Area - Invalid read length
			F108 BATS error: Reserved Area - Address boundary error
			1109 BATS error: Reserved Area - Error reading first copy
			110A BATS error: Reserved Area - Error reading second copy
			F10B BATS error: Reserved Area - Read block error
			110C BATS error: Reserved Area - Write fix soft error
			F10D BATS error: Reserved Area - Write fix hard error
			F10E BATS error: Directory broken
			F10F BATS error: Overlay code load error
			F110 BATS error: Overlay code check

			F111 BATS error: RAM code load error
			F112 BATS error: RAM code check
			F113 BATS error: Config invalid
			F114 BATS error: Log manager invalid
			F115 BATS error: Media tables invalid
			F116 BATS error: Logical-to-physical invalid
			F117 BATS error: Defect manager invalid
			F11D Incorrect Disk Code
			F11F RPO SID invalid
			F121 BATS error: Code download in progress
			F122 BATS error: Performance data read error
			F125 BATS error: Invalid RID/FID
			F12B BATS error: Reserved area - invalid model
			F12C BATS error: Invalid code size
			F12D Format Reserved: FAT size exceeded
			F12E Format Reserved: Insufficient DIRS good
			F12F Format Reserved: Insufficient FATS good
			F131 Flash timeout
			F13B BATS error: SW Target Broken
			F13C BATS error: NCDE DRAM fail
<b>4</b>	<b>44</b>	<b>00</b>	<b>Internal Target Failure</b>
			F203 Internal target failure
			F207 AHB Access Error
			F302 Motor: Unrecovered internal error
			F304 Motor: Unrecovered Open Loop Commutation error
			F306 Motor: Unrecovered No feedback detected error
			F308 Motor: Unrecovered Settle timeout
			F30A Motor: Unrecovered Gross speed error
			F30C Motor: Unrecovered 12V OK error



			F30E Motor: Unrecovered Speed error
			F312 Motor: Unrecovered internal 12V not OK timeout
			F314 Motor: Unrecovered Inductive Sense measurement timeout
			F316 Motor: Unrecovered Spin Sense speed error
			F31A Motor: Unrecovered Target speed error
			F31C Motor: Unrecovered Power driver version error
			F31E Motor: Unrecovered Over current error
			F322 Motor Unrecovered Negative regulator fault
			F324 Motor Unrecovered Module overtemp error
			F326 Motor Unrecovered 12V or 5V OK error
			F328 Motor: Unrecovered unkown error
			F402 Servo: Unrecovered Requested re zero head does not exist
			F404 Servo: Unrecovered Back EMF movement in progress
			F406 Servo: Unrecovered Back EMF timeout error
			F408 Servo: Unrecovered ADC conversion timeout
			F40A Servo: Unrecovered Load/unload calibration error
			F40C Servo: Unrecovered Invalid 5 volts
			F40E Servo: Unrecovered Invalid 12 volts
			F410 Servo: Unrecovered Invalid harmonic requested
			F412 Servo: Unrecovered Gain BEMF Calibration error
			F414 Servo: Unrecovered VOFF BEMF calibration error
			F416 Servo: Unrecovered Invalid temperature
			F418 Servo: Unrecovered Truncated rezero
			F41A Servo: Unrecovered Heads not loaded
			F426 Servo: Unrecovered KT Seek out of range
			F428 Servo: Unrecovered DAC Offset calibration error
			F42A Servo: Unrecovered Load speed error
			F42E Servo: Unrecovered ADC Calibration error
			F430 Servo: Unrecovered ADC Offset error

			F432 Servo: Unrecovered ADC Limit error
			F434 Servo: Unrecovered Balancer Resistance error
			F436 Servo: Unrecovered Balancer Resistance Limit error
			F438 Servo: Unrecovered First Cylinder error
			F43A Servo: Unrecovered Valid Cylinder error
			F43C Servo: Unrecovered ADC Saturation error
			F43E Servo: Unrecovered Latch Break timeout
			F440 Servo: Unrecovered MR Resistance out of range error
			F442 Servo: Servo: Unrecovered VCM Retract error
			F444 Servo: Unrecovered Load Retry error
			F446 Servo Unrecovered DFT Sharp error
			F448 Servo Unrecovered Load/Unload state error
			F44A Servo Unrecovered TCFR out-of-range error
			F44C Servo: Unrecovered Measure GMR Timeout
			F44E Servo: Unrecovered Coil Resistance Measurement Failure
			F460 Servo: Unrecovered WCS Hang Error
			F462 Servo: Unrecovered DFT Timeout Error
			F464 Servo: Unrecovered SDM Timeout Error
			F466 Servo: Unrecovered RRO Write Error
			F468 Servo: Unrecovered Velocity Error
			F470 Servo: Unrecovered VCM Free Speed Error
			F472 Servo: Unrecovered Emergency Brake Timeout
			F474 Servo: Unrecovered Excessive Current Error
			F476 Servo: Unrecovered Excessive Velocity Error
			F478 Servo: Hard RROF SDM Timeout
			F47A Servo: Hard Milli CAL Error
			F603 Channel/AE target failure
			F604 Channel/AE calibration error
			F605 Channel/AE MR Calibration Error

			F607 Unrecovered data with PPM or precomp load
			F617 Unrecovered channel error
			F619 Unrecovered AE thermal asperity found
			F61B Unrecovered AE open MR element error
			F61D Unrecovered AE IC over temperature error
			F61F unrecovered AE IP clock count error
			F621 Unrecovered AE high MR current error
			F623 Unrecovered AE write data BLS error
			F625 Unrecovered AE invalid head address error
			F627 Unrecovered AE power supply error
			F629 Unrecovered AE open write head error
			F62B Unrecovered AE write transition error
			F62D Unrecovered AE no write head current error
			F633 Unrecovered Channel write synch unlock error
			F635 Unrecovered AE Short write read head error
			F637 Unrecovered AE Short write head error
			F639 Unrecovered AE Non-selected write head error
			F63B Unrecovered AE Write current in read error
			F63D Unrecovered AE IH open short error
			F63F Unrecovered AE IH delay error
			F641 Unrecovered Channel coarse tune timeout error
			F643 Unrecovered AE Readback error
			F645 Unrecovered Channel coarse tune timeout error
			F647 Unrecovered AE Write Gate during Idle Fault
			F649 Unrecovered Channel Frequency Change Error
			F64B Unrecovered Channel Write Auxiliary Error
			F64D Unrecovered Channel Write Invalid Error
			F64F Unrecovered Channel Parity Pulse Error
			F651 Unrecovered Channel PLL Error

			F653 Unrecovered Channel Write Clock Error
			F655 Unrecovered Channel PLL Write Safe Error
			F657 Unrecovered Channel No Write Clock Error
			F659 Unrecovered Channel No NRZ Clock Error
			F65B Unrecovered Channel Cal Block Fault Error
			F65D Unrecovered Channel Mode Overlap Fault Error
			F65F Unrecovered Channel Preamble Fault Error
			F661 Unrecovered Channel WPLO Error
			F663 Unrecovered Channel Write Gate Overlap Fault Error
			F665 Unrecovered Channel Write Gate Fault Error
			F667 Unrecovered Channel Buffer Overflow Write Error
			F669 Unrecovered Channel Buffer Overflow Write Error
			F66B Unrecovered Channel Write Parity Error
			F66D Unrecovered Channel Buffer Overflow Write Error
			F66F Unrecovered Channel Buffer Underflow Write Error
			F671 Unrecovered Channel RPLO Late Error
			F673 Unrecovered Channel Bit Count Late Error
			F675 Hard Chn Prea Cnt Fault Error
			F677 Unrecovered Channel Pfault Read Error
			F679 Unrecovered Channel Pfault Write Error
			F67B Unrecovered Channel Last Data Fault Error
			F67D Unrecovered Channel WRPO Fault Error
			F67F Hard Forced Chan Fault Error
			F681 Unrecovered Channel PLLFloor Error
			F683 Unrecovered Channel Losslock Error
			F685 Unrecovered Channel VGA Floor Error
			F687 Unrecovered Channel Buffer EVGA Floor Error
			F689 Unrecovered Channel TA Detector Error
			F68D Unrecovered Channel ZGR Flag Error

			F68F Unrecovered Channel DPLL Freq Flag Error
			F695 Unrecovered Channel Flaw Sig Sync Error
			F697 Unrecovered Channel ACQ Flag Error
			F699 Unrecovered Channel No Clock Error
			F69B Unrecovered Channel PLL Losslock Error
			F69D Unrecovered AE TFC Short Error
			F69F Unrecovered AE MR Element Short Error
			F713 Unrecovered LBA MEDC error
			F717 Unrecovered write overrun
			F71B Unrecovered MEDC overrun
			F71D Unrecovered DRAM CRC error
			F71F Unrecovered ID Parity error
			F732 Unrecovered Write Fault
			F75A Unknown unrecovered error
			F76B Unrecovered No NRZ clock error
			F76F Media Hard Chan RDY Error
			F779 Media Hard LBA FIFO Error
			F787 Unrecovered LLI Underrun error
			F788 Media Hard SAT FIFO Underrun
			F789 Media Hard SAT FIFO Overrun
			F78A Media Hard SAT SCT Overrun
			F78B Media Hard SAT Xfer End Mismatch
			F78C Media Hard SAT DMA Data not Rdy
			F78D Media Hard SAT General Err
			F78E Media Hard SAT Chan Rdy Err
			F793 Unrecovered MEDC WrdData Not Ready error
			F795 Unrecovered DMA timeout error
			F799 Unrecovered ID Not Found error
			F79D Unrecovered Channel Read Timeout error

			F7B5 Unrecovered Shock sensor error
			F7C1 Unrecovered End sector check error
			F7C3 Unrecovered Read CRC error
			F7C5 Unrecovered DRAM ECC error
			F7C7 Unrecovered DRAM ECC LBA error
			FCxx Unable to read RID or FID number xx
<b>4</b>	<b>40</b>	<b>81</b>	<b>DRAM Failure</b>
			F12A DRAM test error
<b>4</b>	<b>40</b>	<b>90</b>	<b>Diagnostic Failure</b>
			F118 BATS#2 error: Seek test error
<b>4</b>	<b>40</b>	<b>A0</b>	<b>Diagnostic Failure</b>
			F119 BATS#2 error: Read/write test error
			F11B BATS#2 error: CRC test error
			F11C BATS#2 error: XOR test error
			F136 BATS#2 error: End-to-End test error
			F137 Flash ECC error
			F13B SW target broken
			F13C NCDE DRAM Error
<b>4</b>	<b>44</b>	<b>0B</b>	<b>Vendor Unique - Internal Target Failure</b>
			F310 Motor: Unrecovered Spindle Current error
			F318 Motor: Unrecovered Spin Sense timeout
			F320 Motor: Unrecovered System clock watchdog error
			F32A Motor: Unrecovered VCM DAC watchdog error
			F332 Motor: Unrecovered Invalid Standby RPM request error
			F334 Motor: Unrecovered Invalid Invocation State error
			F336 Motor: Unrecovered Hardware Retract timeout error
			F338 Motor: Unrecovered Predriver Thermal Limit Exceeded error
			F33A Motor: Unrecovered Hard Predriver VM OI error
			F33C Motor: Unrecovered Predriver Watchdog Fsys error

			F33E Motor: Unrecovered Predriver Watchdog DAC error
			F340 Motor: Unrecovered Predriver Speed Low error
			F342 Motor: Unrecovered Predriver UV Vboost error
			F344 Motor: Unrecovered Predriver NREG UV error
			F346 Motor: Unrecovered Predriver Ext NPOR error
			F348 Motor: Unrecovered Predriver Reg UV error
			F34A Motor: Hard Predriver Fault
			F34C Motor: Hard Predriver Fault
			F34E Motor: Hard Predriver Fault
			F350 Motor: Hard Predriver Fault
			F352 Motor: Hard Predriver Fault
			F354 Motor: Hard Predriver Fault
			F356 Motor: Hard Predriver Fault
			F358 Motor: Hard Predriver Fault
<b>4</b>	<b>44</b>	<b>F2</b>	<b>Vendor Unique - Internal Target Failure</b>
			F134 Head Health Check data compare error
<b>4</b>	<b>44</b>	<b>F6</b>	<b>Vendor Unique - Internal Target Failure</b>
			F135 Head Health Check unrecovered media error
<b>4</b>	<b>44</b>	<b>F7</b>	<b>Vendor Unique - Internal Target Failure</b>
			F7B7 Recovered Write Compare error
<b>4</b>	<b>44</b>	<b>F9</b>	<b>Vendor Unique - Internal Target Failure</b>
			F452 Servo: Unrecovered SHARP Parity Rate Error
			F456 Servo: Unrecovered SHARP Decode Rate Error
			F45A Servo: Unrecovered SHARP Timeout Rate Error
			F45E Servo: Unrecovered SHART Other Rate Error
<b>4</b>	<b>44</b>	<b>FA</b>	<b>Vendor Unique - Internal Target Failure</b>
			F450 Servo: Unrecovered SHARP Parity Error
			F454 Servo: Unrecovered SHARP Decode Error
			F458 Servo: Unrecovered SHARP Timeout Error

			F458 Servo: Unrecovered SHARP Timeout Error
<b>4</b>	<b>81</b>	<b>00</b>	<b>Vendor Unique - Internal Logic Error</b>
			F549 LA Check error
			F56F Log dump data memory error
			F602 Channel/AE hard logic error
			<b>Sense Key = Illegal Request</b>
<b>5</b>	<b>15</b>	<b>00</b>	<b>PHY Test In Progress Error</b>
			F50D PHY Test In Progress error
<b>5</b>	<b>1A</b>	<b>00</b>	<b>Parameter List Length Error</b>
			F820 Parameter list length error
<b>5</b>	<b>20</b>	<b>00</b>	<b>Invalid Command Operation Code</b>
			F821 Invalid opcode in CDB
<b>5</b>	<b>21</b>	<b>00</b>	<b>Logical Block Address out of Range</b>
			F822 LBA out of range
<b>5</b>	<b>24</b>	<b>00</b>	<b>Invalid Field in CDB</b>
			F823 Illegal request - invalid field in CDB
			F829 SPC buffer not allocated
<b>5</b>	<b>24</b>	<b>F3</b>	<b>Vendor Unique - Illegal Request</b>
			F82A Formatted without P-List
<b>5</b>	<b>25</b>	<b>00</b>	<b>Logical Unit Not Supported</b>
			FA24 Invalid LUN
<b>5</b>	<b>26</b>	<b>00</b>	<b>Invalid Field in Parameter List</b>
			F825 Illegal request - invalid field in parameter list
			F826 Unsupported log page
<b>5</b>	<b>26</b>	<b>02</b>	<b>Parameter Value Invalid</b>
			F120 BATS error: Code compatibility failure
			F126 BATS error: Code checksum error
			F127 BATS error: Invalid header
			F130 BATS error: Incorrect Customer code



			F13D BATS error: Invalid Code Signature
			F830 Illegal Request Sequence error
<b>5</b>	<b>26</b>	<b>04</b>	<b>Invalid Release of Active Persistent Reservation</b>
			F828 Invalid release of persistent reservation
<b>5</b>	<b>2A</b>	<b>03</b>	<b>Reservation Conflict</b>
			F536 Reservation conflict
<b>5</b>	<b>2C</b>	<b>00</b>	<b>Illegal Request Sequence Error</b>
			F511 Illegal Request Sequence Error
<b>5</b>	<b>49</b>	<b>00</b>	<b>Invalid Message Error</b>
			F512 Invalid message
<b>5</b>	<b>55</b>	<b>04</b>	<b>Insufficient Registration Resources</b>
			F567 Insufficient registration resources
			<b>Sense Key = Unit Attention</b>
<b>6</b>	<b>0B</b>	<b>01</b>	<b>Unit Attention -Temperature</b>
			3A02 Unit Attention Temperature
<b>6</b>	<b>0B</b>	<b>03</b>	<b>Unit Attention -Background Selftest Failure</b>
			3A03 Unit Attention Background selftest failure
<b>6</b>	<b>0B</b>	<b>04</b>	<b>Unit Attention -Background Pre-Scan Failure</b>
			3A04 Unit Attention - Background pre-scan failure
<b>6</b>	<b>0B</b>	<b>05</b>	<b>Unit Attention -Background Media Scan Failure</b>
			3A05 Unit Attention - Background media scan failure
<b>6</b>	<b>28</b>	<b>00</b>	<b>Not Ready To Ready Transition (Format completed)</b>
			F514 Not ready to read transition
<b>6</b>	<b>29</b>	<b>00</b>	<b>Unit Attention - Login Reset</b>
			F515 Login reset (FC-AL only)
<b>6</b>	<b>29</b>	<b>01</b>	<b>Unit Attention - POR Occurred</b>
			F516 Power on reset
<b>6</b>	<b>29</b>	<b>02</b>	<b>Unit Attention - SCSI Bus Reset Occurred</b>
			F517 LIP Reset (FC-AL), SAS Hard Reset (SAS)
<b>6</b>	<b>29</b>	<b>03</b>	<b>Unit Attention - Bus Device Reset Occurred</b>

			F518 Target Reset (FC-AL), LUN Reset (SAS)
<b>6</b>	<b>29</b>	<b>04</b>	<b>Unit Attention - Self Initiated Reset Occurred</b>
			F519 Self initiated reset
<b>6</b>	<b>29</b>	<b>05</b>	<b>Transceiver Changed to SE</b>
			F548 Device Control Hard Reset received
<b>6</b>	<b>29</b>	<b>07</b>	<b>I_T Nexus Loss Occurred</b>
			F554 I_T Nexus Loss Occurred (SAS only)
<b>6</b>	<b>2A</b>	<b>01</b>	<b>Mode Parameters Changed</b>
			F51C Mode parameters changed
<b>6</b>	<b>2A</b>	<b>02</b>	<b>Log Parameters Changed</b>
			F51D Log parameters changed
<b>6</b>	<b>2A</b>	<b>03</b>	<b>Reservations Preempted</b>
			F51E Reservations pre-empted
<b>6</b>	<b>2A</b>	<b>04</b>	<b>Reservations Released</b>
			F51F Reservations released
<b>6</b>	<b>2A</b>	<b>05</b>	<b>Registrations Released</b>
			F520 Registrations pre-empted
<b>6</b>	<b>2F</b>	<b>00</b>	<b>Commands Cleared by Another Initiator</b>
			F521 Commands cleared by another initiator
<b>6</b>	<b>2F</b>	<b>01</b>	<b>Commands Cleared by Power Loss Notification</b>
			F573 Commands cleared due to power failure event (SAS)
<b>6</b>	<b>3F</b>	<b>01</b>	<b>Microcode has been changed</b>
			F522 Microcode changed
<b>6</b>	<b>3F</b>	<b>03</b>	<b>Inquiry Parameters Changed</b>
			F523 Inquiry parameters changed
<b>6</b>	<b>3F</b>	<b>05</b>	<b>Device Identifier Changed</b>
			F537 Device identifier changed
<b>6</b>	<b>5D</b>	<b>21</b>	<b>Unit Attention – SMART Milliactuator Error</b>
			3A21 SMART: Milliactuator Err (unit attention sense)
<b>6</b>	<b>5D</b>	<b>22</b>	<b>Unit Attention – SMART Unrecovered Over Temperature Reached</b>

			3A22 SMART: Extreme over temperature reached (unit attention sense)
<b>6</b>	<b>5D</b>	<b>50</b>	<b>Unit Attention – SMART Load/Unload Cycle Threshold Reached</b>
			3A50 SMART: Load/unload cycle count threshold reached
<b>6</b>	<b>5D</b>	<b>5B</b>	<b>Unit Attention – SMART Spin-up Retry Count Threshold Reached</b>
			3A5B SMART: Spin-up retry count threshold reached
<b>6</b>	<b>5D</b>	<b>62</b>	<b>Unit Attention – SMART Read/Write Error Rate Threshold Reached</b>
			3A32 SMART: Read error rate threshold reached
			3A4A SMART: Write error rate threshold reached
<b>6</b>	<b>5D</b>	<b>63</b>	<b>Unit Attention – SMART Seek Error Rate Threshold Reached</b>
			3A43 SMART: Seek error rate threshold reached
<b>6</b>	<b>5D</b>	<b>64</b>	<b>Unit Attention – SMART Available Spare Threshold Reached</b>
			3A14 SMART: Available Spare sector threshold reached
<b>6</b>	<b>5D</b>	<b>66</b>	<b>Unit Attention – SMART Spin Up Time Threshold Reached</b>
			3A56 SMART: Spin-up time threshold reached
<b>6</b>	<b>5D</b>	<b>FF</b>	<b>Unit Attention – SMART Test Warning Threshold Reached</b>
			3AFF SMART: Test warning threshold reached
			<b>Sense Key = Aborted Command</b>
<b>B</b>	<b>0E</b>	<b>01</b>	<b>Invalid Target Port Transfer Tag Received</b>
			F561 Information unit too short (SAS only)
<b>B</b>	<b>0E</b>	<b>02</b>	<b>Information Unit Too Long</b>
			F562 Information unit too long.
<b>B</b>	<b>10</b>	<b>01</b>	<b>Aborted Command – End-to-End Guard Check</b>
			F568 End-to-End Data Protection Guard check
<b>B</b>	<b>10</b>	<b>02</b>	<b>Aborted Command – End-to-End Application Tag Check</b>
			F569 End-to-End Data Protection Application Tag check
<b>B</b>	<b>10</b>	<b>03</b>	<b>Aborted Command – End-to-End Reference Tag Check</b>
			F56A End-to-End Data Reference Tag check
<b>B</b>	<b>3F</b>	<b>0F</b>	<b>Aborted Command - Echo Buffer Overwritten</b>
			F544 Echo buffer overwritten

<b>B</b>	<b>44</b>	<b>00</b>	<b>Internal Target Failure</b>
			F52D Buffer CRC error on read
			F52E Internal target failure - Host Interface
			F54A Xfer Ready credit exceeded (FC-AL only)
			F54B Xfer length error (FC-AL only)
			F56B ECC error in DRAM customer data area
			F56C Uncorrectable DRAM ECC error
			F570 Host interface CRC error
			F574 Host interface unsupported hardware
			F57B Host Interface Synchronous CRC LBA Error
			F57C HI ATA Commands out of seq
			F62F Unrecovered Channel NRZ Clear time out
			F741 MEDIA OCT TIMEOUT NOT DISPATCHED
			F742 MEDIA OCT TIMEOUT IN RECOVERY
			F743 MEDIA OCT TIMEOUT EXECUTING
			F75C Internal media access timeout
			F761 Read/write command timeout
			F772 DASH starting timeout
			F773 ID table timeout
			F774 Servo timeout
			F775 Buffers timeout
			F776 DASH done timeout
			F777 DASH unknown timeout
			F77B Unrecovered abort EOS error
			F77E MEDIA WRITE ERROR RECOVERY TIMEOUT
			F77F MEDIA READ ERROR RECOVERY TIMEOUT
			F7D0 Pre-load timeout
<b>B</b>	<b>47</b>	<b>01</b>	<b>Data Phase CRC Error</b>
			F54E Data Phase CRC Error

<b>B</b>	<b>4B</b>	<b>00</b>	<b>Data Phase Error</b>
			F53E Data phase error
<b>B</b>	<b>4B</b>	<b>02</b>	<b>Too Much Write Data</b>
			F560 Too much write data (SAS only)
<b>B</b>	<b>4B</b>	<b>03</b>	<b>ACK/NAK Timeout</b>
			F551 ACK/NAK Timeout (SAS only)
			F57D Break Received (SAS only)
<b>B</b>	<b>4B</b>	<b>04</b>	<b>NAK Received</b>
			F550 NAK Received (SAS only)
<b>B</b>	<b>4B</b>	<b>05</b>	<b>Data Offset Error</b>
			F552 Bad parameter offset (SAS only)
<b>B</b>	<b>4B</b>	<b>06</b>	<b>Initiator Response Timeout</b>
			F555 Initiator response timeout (SAS only)
<b>B</b>	<b>4E</b>	<b>00</b>	<b>Overlapped Commands Attempted</b>
			F534 Overlapped command attempted
<b>B</b>	<b>4F</b>	<b>00</b>	<b>Command Aborted Due To Loop Initialization</b>
			F53F Abort by LIP (FC-AL only), Abort by OOB (SAS)
			<b>Sense Key = Miscompare</b>
<b>E</b>	<b>1D</b>	<b>00</b>	<b>Miscompare During Verify Operation</b>
			F535 Miscompare during verify

### 22.2.9 FRU: Field Replaceable Unit (Byte 14)

The FRU (Field Replaceable Unit) field value will always be zero.

**Note:** The FRU field may be used to store vendor specific information in certain firmware builds.

### 22.2.10 Sense Key Specific (Byte 15 through 17)

The definition of this field is determined by the value of the sense key field.

### 22.2.10.1 Sense Key Specific - Illegal Request (Sense Key = 5h)

Error field pointer is returned.

**Table 248: Field Pointer Bytes**

Byte	Bit							
	7	6	5	4	3	2	1	0
15	SKSV	C/D	Reserved		BPV	Bit Pointer		
16 17	(MSB) Field Pointer							(LSB)

**SKSV** Sense-key specific valid

**0** Sense-key specific field is not valid.

**1** Sense-key specific field is valid.

**C/D** Command/Data

**0** Indicates that the illegal parameter was in the data parameters sent by the initiator during DATA OUT phase

**1** Indicates that the illegal parameter was in the command descriptor block.

**BPV** Bit Pointer Valid

**0** Bit pointer field is not valid.

**1** Bit pointer field is significant.

**Bit Pointer** Indicates which bit of the byte number reported in Field Pointer is the bit in error. When a multiple bit field is in error, the pointer points to the most significant bit of the field.

**Field Pointer** Indicates which bytes of the command descriptor block or of the parameter data were in error. Bytes are numbered starting from zero, as shown in the tables describing the commands and parameters. When a multiple byte field id is in error, the pointer points to the most significant byte of that field.

### 22.2.10.2 Sense Key Specific -Recovered (Sense Key = 1h) or Medium (Sense Key = 3h) or Hardware (Sense Key = 4h)

Hardware (Sense Key = 4h) or Medium Error (Sense Key = 3h)

Actual Retry Count is reported.

**Table 249: Actual Retry Count**

Byte	Bit							
	7	6	5	4	3	2	1	0
15	SKSV	Reserved						
16	Secondary Step				ERP Type			
17	Actual Retry Count							

**SKSV** Sense-key specific valid

**0** Actual Retry Count is not valid.

**1** Actual Retry Count is valid.

**Actual Retry Count** Number of retry steps used in attempting to recover from the error condition.

**Secondary Step** Secondary error recovery step (valid for servo errors only).

**ERP Type** Error recovery table branch for this error. Valid values are shown in the table below.

Recovery Type	ERP Type
Read	0x00
Verify	0x01
Write	0x02
Seek	0x03
Read, Sync Byte branch	0x04
Read, Thermal Asperity branch	0x05
Read, Minus Mod branch	0x06
Verify, Sync Byte branch	0x07
Verify, Thermal Asperity branch	0x08
Verify, Minus Mod branch	0x09

### 22.2.10.3 Not Ready (Sense key = 2h)

These fields are defined for the Format unit (04h) command with the Immediate bit set to one and the Send Diagnostic (1Dh) command with Background self-test function.

Progress indication is returned.

**Table 250: Progress Indication**

Byte	Bit							
	7	6	5	4	3	2	1	0
15	SKSV	Reserved						
16	Progress Indication							
17								

**SKSV**

Sense-key specific valid

**0** Progress Indication is not valid.

**1** Progress Indication is valid.

**Progress Indication**

Indicates a percent complete in which the returned value is the numerator that has 10000h as its denominator.



### 22.2.11 Reserved (Byte 18 through 19)

Reserved fields are filled with zero.

### 22.2.12 Vendor unique error information (Byte 20 through 23)

This field gives detailed information about the error. It contains a unique code which describes where the error was detected and which piece of hardware or microcode detected the error depending on current operation.

### 22.2.13 Physical Error Record (Product Specific Information) (Byte 24 thru 29)

- ILI = 1 - This field contains zeros.
- ILI = 0 - These bytes contain the physical location of the error in cylinder, head, and sector. Bytes 24, 25, and 26 are cylinder high, middle and low bytes respectively, of the cylinder number. Byte 27 is the head number. Bytes 28 and 29 are the high and low bytes, respectively of the sector number.

If the head is undetermined, bytes 24, 25, and 26 are set to 0FFFFFFh. If the head number is undetermined, byte 27 is set to 0FFh. If cylinder, head, and sector have no relevance the error, bytes 24 through 29 will all be set to 0FFFFFFFFFFFFh for Valid = 0 and ILI = 0. This Physical Error Record field is valid for Sense Key 1, 3, and 4 only.

Valid	ILI	Description
1	0	Cylinder Number (bytes 24-26) Head number (byte 27) Sector Number (bytes 28-29)
1	1	0x000000000000
0	x	0x000000000000 - (not used/invalid)

## 22.3 Descriptor Format Sense Data

The descriptor format sense data for response codes 72h (current errors) and 73h (deferred errors) is defined below.

**Table 251: Descriptor Format Sense Data**

Byte	Bit							
	7	6	5	4	3	2	1	0
0	Reserved= 0		Response Code (72h or 73h)					
1	Reserved			Sense Key				
2	Additional Sense Code							
3	Additional Sense Code Qualifier							
4-6	Reserved							
7	Additional Sense Length (n-7)							
8-m	Sense Data Descriptor # 1							
m...x	. . . . .							
x -n	Sense Data Descriptor # K							

**Response Code:** 72h Current Error. See section 22.1.3 for more details.

73h Deferred Error. See section 22.1.3 for more details.

The **Sense Key** definitions is the same as fixed format sense data.

The **Additional Sense Code/Qualifier** definitions is the same as fixed format sense data.

The Value of the **Additional Sense Length** indicates the remaining number of bytes in the sense data

**Sense data descriptors ( Byte 8 through n)** provide specific sense information. The general format of a sense data descriptor is shown below:

**Table 252: Sense Data Descriptor Format**

Byte	Bit							
	7	6	5	4	3	2	1	0
0	Descriptor Type							
1	Additional Length (n-1)							
2-n	Sense Data Descriptor Specific							

The **Descriptor Type** identifies the type of a sense data descriptor. (Supported types are listed below)

**Table 253: Supported Descriptor Types**

Type Code	Description
00h	Information Sense Data Descriptor
01h	Command-specific Sense Data Descriptor
02h	Sense Key Specific Sense Data Descriptor
03h	Field Replaceable Unit Sense Descriptor
05h	Block Command Sense Data Descriptor
80h	Vendor Unique Unit Error Code Sense Data Descriptor
81h	Vendor Unique Physical Error Record Sense Data Descriptor

The **ADDITIONAL LENGTH** field indicates the number of sense data descriptor specific bytes that follow in the sense data descriptor.

## 22.3.1 Order of Sense Descriptors

The drive may return up to 7 sense data descriptors in byte 8 through byte 59 of the sense data, up to the number of sense data bytes allowed (see table 254). The sense descriptors returned will always be in the order shown in the table below, regardless of whether a descriptor contains valid information or not.

**Table 254: Sense Data Descriptor List**

Byte	Bit							
	7	6	5	4	3	2	1	0
0-7	Common Headers							
8-19	Information SenseData Descriptor							
20-31	Command-specific Sense Data Descriptor							
32-39	Sense Key Specific Sense Data Descriptor							
40-43	Field Replaceable Unit (FRU) Sense Data Descriptor							
44-47	Block Command Sense Data Descriptor							
48-51	Vendor Unique Unit Error Code Sense Data Descriptor							
51-59	Vendor Unique Physical Error Record Sense Data Descriptor							

## 22.3.2 Sense Data Descriptor Definitions

### 22.3.2.1 Information Sense Data Descriptor (Byte 8 - 19)

The Information Sense Data Descriptor is stored in bytes 8 through 19 of the descriptor format sense data. Format of the Information Sense Data Descriptor is shown in Table 255

**Table 255: Information Sense Data Descriptor Format**

Byte	Bit							
	7	6	5	4	3	2	1	0
0	Descriptor Type (00h)							
1	Additional Length (0Ah)							
2	VALID	Reserved						
3	Reserved							
4-11	Information							

**Descriptor Type** Set to 00h for Information Sense Data Descriptor.

**Additional Length** Set to 0Ah for Information Sense Data Descriptor.

**VALID** This bit is set to 1 when content of the Information field is valid, and set to 0 if the Information field is invalid.

**Information** This field contains an LBA or other information depending on the value of the ILI bit in the Block Command Sense Descriptor (See section 22.3.2.5).

- ILI = 0 (or if the descriptor is not present): The Information field contains the unsigned LBA associated with the sense key. The LBA reported will be within the LBA range of the command as defined in the CDB.

**Note:** An LBA other than the command LBA may be reported on the Reassign Block (07h) command.

- ILI = 1: The Information field contains the difference (residue) of the requested length in bytes. Negative values are indicated by two's complement notation

### 22.3.2.2 Command-specific Sense Data Descriptor (Byte 20 - 31)

The Command-specific Sense Data Descriptor is stored in bytes 20 through 31 of the descriptor format sense data. Format of the format of Command-specific Sense Data Descriptor is shown in Table 256.

**Table 256: Command-specific Sense Data Descriptor Format**

Byte	Bit							
	7	6	5	4	3	2	1	0
0	Descriptor Type (01h)							
1	Additional Length (0Ah)							
2	Reserved							
3	Reserved							
4-11	Command-Specific Information							

**Descriptor Type** Set to 01h for Command-specific Sense Data Descriptor.

**Additional Length** Set to 0Ah for Command-specific Sense Data Descriptor.

**Command-specific Information** The value of this field is set the same ways as Command Specific Information field in fixed format sense data (See section 22.2.7)

### 22.3.2.3 Sense Key Specific Sense Data Descriptor (Byte 32 - 39)

The Sense-key Specific Sense Data Descriptor is stored in bytes 32 through 39 of the descriptor format sense data. Format of Sense-key Specific Sense Data Descriptor is shown in table 257.

**Table 257: Information Sense Data Descriptor Format**

Byte	Bit							
	7	6	5	4	3	2	1	0
0	Descriptor Type (02h)							
1	Additional Length (06h)							
2	Reserved							
3	Reserved							
4	SKSV	Sense Key Specific Bits						
5-6	Sense Key Specific Bytes							
7	Reserved							

**Descriptor Type** Set to 02h for Sense-key specific Sense Data Descriptor.

**Additional Length** Set to 06h for Sense-key specific Sense Data Descriptor.

Fields in byte 4 through 5 (including the **SKSV** bit, **Sense-Key Specific Bits**, and **Sense-Key Specific Bytes**): These fields are set the same ways as byte 15 - 17 in fixed format sense data (See section 22.2.10 for details).

### 22.3.2.4 Field Replaceable Unit (FRU) Sense Data Descriptor (Byte 40 - 43)

The Field Replaceable Unit (FRU) Sense Data Descriptor is stored in bytes 40 through 43 of descriptor format sense data. Format of Field Replaceable Unit (FRU) Sense Data Descriptor is shown in table 258.

**Table 258: Field Replaceable Unit Sense Data Descriptor Format**

Byte	Bit							
	7	6	5	4	3	2	1	0
0	Descriptor Type (03h)							
1	Additional Length (02h)							
2	Reserved							
3	Field Replaceable Unit Code							

**Descriptor Type:** Set to 03h for Field Replaceable Unit Sense Data Descriptor.

**Additional Length:** Set to 02h for Field Replaceable Unit Sense Data Descriptor.

**Field Replaceable Unit Code:** This field is set the same way as the Field Replaceable Unit Code of fixed format sense data. (See section 22.2.9 for details).

### 22.3.2.5 Block Command Sense Descriptor (Byte 44 - 47)

The Block Command Sense Data Descriptor is stored in bytes 44 through 47 of descriptor format sense data. Format of the Block Command Sense Data Descriptor is shown in table 259.

**Table 259: Block Command Sense Data Descriptor Format**

Byte	Bit							
	7	6	5	4	3	2	1	0
0	Descriptor Type (05h)							
1	Additional Length (02h)							
2	Reserved							
3	Reserved=0		ILI	Reserved=0				

**Descriptor Type:** Set to 05h for Block Command Sense Data Descriptor.

**Additional Length:** Set to 02h for Block Command Sense Data Descriptor.

**ILI:** Value of the ILI bit is set to indicate what type of value is stored in the Information field of the Information Sense Data Descriptor (see section 22.3.2.1 for details):

### 22.3.2.6 Vendor Unique Unit Error Sense Data Descriptor (Byte 48 – 51)

The Vendor Unique Unit Error Code Sense Data Descriptor is stored in bytes 48 through 51 of descriptor format sense data. Format of the Vendor Unique Unit Error Code Sense Data Descriptor is shown in table 260.

**Table 260: Vendor Unique Unit Error Code Sense Data Descriptor**

Byte	Bit							
	7	6	5	4	3	2	1	0
0	Descriptor Type (80h)							
1	Additional Length (02h)							
2-3	Unit Error Code (UEC)							

**Descriptor Type:** Set to 80h for Vendor Unique Unit Error Code Sense Data Descriptor.

**Additional Length:** Set to 02h for Vendor Unique Unit Error Code Sense Data Descriptor.

**Unit Error Code:** This field contains the same value as the Vendor Unique Error Information field in fixed format sense data which gives detailed information about the error (See section 22.2.12). It contains a unique code which describes where the error was detected and which piece of hardware or microcode detected the error depending on current operation

### 22.3.2.7 .Vendor Unique Physical Error Record Sense Data Descriptor (Byte 52-59)

The Vendor Unique Physical Error Record Sense Data Descriptor is stored in bytes 52 through 59 of descriptor format sense data.. Format of the Vendor Unique Physical Error Record Sense Data Descriptor is shown in table 261 .

**Table 261: Vendor Unique Physical Error Record Sense Data Descriptor**

Byte	Bit							
	7	6	5	4	3	2	1	0
0	Descriptor Type (81h)							
1	Additional Length (06h)							
2-7	Physical Error Record							

**Descriptor Type:** Set to 81h for Vendor Unique Unit Physical Error Record Sense Data Descriptor.

**Additional Length:** Set to 06h for Vendor Unique Unit Physical Error Record Sense Data Descriptor.

**Physical Error Record:** This field is set the same way as the Physical Error Record in fixed format sense data.( See section 22.2.13 for details).

## 23.0 Appendix. UEC list

Following is the list of Unit Error Codes and associated descriptions. The Unit Error Codes are returned by the target in sense data bytes 20-21.

The list of Unit Error Codes and descriptions does not have a direct correlation to the error descriptions and Sense Key/Code/Qualifier descriptions in Section 20.0, “Additional information” on page 269. These codes are used internally by HGST and may change without notice.

### How to find a specific UEC

The second hex digit indicates the grouping, e.g. interface, media, servo, etc. types of errors. The table is sorted without regard to the first hex digit; instead, sorting is by the least significant three hex digits.

**Table 262: Unit Error Codes**

UEC	Description
0000	No error
F101	BATS error: Reserved Area - Invalid request
F102	BATS error: Reserved Area - Broken
F103	BATS error: Reserved Area - Invalid version
F104	BATS error: Reserved Area - Invalid checksum
F105	BATS error: Reserved Area - Invalid eyecatcher
F106	BATS error: Reserved Area - Invalid main header checksum
F107	BATS error: Reserved Area - Invalid read length
F108	BATS error: Reserved Area - Address boundary error
1109	BATS error: Reserved Area - Error reading first copy
110A	BATS error: Reserved Area - Error reading second copy
F10B	BATS error: Reserved Area - Read block error
110C	BATS error: Reserved Area - Write fix soft error
F10D	BATS error: Reserved Area - Write fix hard error
F10E	BATS error: Directory broken
F10F	BATS error: Overlay code load error
F110	BATS error: Overlay code check
F111	BATS error: RAM code load error
F112	BATS error: RAM code check
F113	BATS error: Config invalid
F114	BATS error: Log manager invalid
F115	BATS error: Media tables invalid
F116	BATS error: Logical-to-physical invalid
F117	BATS error: Defect manager invalid
F118	BATS#2 error: Seek test error
F119	BATS#2 error: Read/write test error
F11B	BATS#2 error: CRC test error
F11C	BATS#2 error: XOR test error
F11D	Incorrect Disk Code

<b>UEC</b>	<b>Description</b>
F11F	RPO SID invalid
F120	BATS error: Code Compatibility Failure
F121	BATS error: Code download in progress
F122	BATS error: Performance data read error
F123	Invalid request to enter sleep mode
F124	Bring-up error
F125	BATS error: Invalid RID/FID
F126	BATS error: Code checksum error
F127	BATS error: Invalid header
F128	DRAM test in progress
F129	DRAM test complete
F12A	DRAM test error
F12B	BATS error: Reserved area - invalid model
F12C	BATS error: Invalid code size
F130	BATS error: Incorrect Customer Code
F131	Flash timeout
F132	GEM FH track read error
F133	BATS error: Vendor ID mismatch
F134	Head Health Check data compare error
F135	Head Health Check unrecovered media error
F136	BATS#2 error: End-To-End Data Protection error
F137	Flash ECC error
F13B	BATS error: SW Target broken
F13C	BATS error: NCDE DRAM failure
F13D	BATS error: Invalid Code Signature
1201	Error in UEC class
1202	Error in UEC cause
F203	Internal target failure
F204	Reassign reserved area media error
F205	G-list full - can't reassign any more sectors
F206	No spares available
F207	AHB Access Error
F302	Motor: Unrecovered internal error
1303	Motor: Recovered Open Loop Commutation failure
F304	Motor: Unrecovered Open Loop Commutation failure
1305	Motor: Recovered No feedback detected error
F306	Motor: Unrecovered No feedback detected error
1307	Motor: Recovered Settle timeout
F308	Motor: Unrecovered Settle timeout



<b>UEC</b>	<b>Description</b>
1309	Motor: Recovered Gross speed error
F30A	Motor: Unrecovered Gross speed error
130B	Motor: Recovered 12V OK error
F30C	Motor: Unrecovered 12V OK error
130D	Motor: Recovered Speed error
F30E	Motor: Unrecovered Speed error
130F	Motor: Recovered Spindle Current error
F310	Motor: Unrecovered Spindle Current error
1311	Motor: Recovered Internal 12V not OK timeout
F312	Motor: Unrecovered Internal 12V not OK timeout
1313	Motor: Recovered Inductive Sense measurement timeout
F314	Motor: Unrecovered Inductive Sense speed error
F315	Motor: Recovered Spin Sense speed error
F316	Motor: Unrecovered Spin Sense speed error
1317	Motor: Recovered Spin Sense timeout
F318	Motor: Unrecovered Spin Sense timeout
1319	Motor: Recovered Target speed error
F31A	Motor: Unrecovered Target speed error
F31C	Motor: Unrecovered Power driver version error
F31E	Motor: Unrecovered Over current error
131F	Motor: Recovered System clock watchdog error
F320	Motor: Unrecovered System clock watchdog error
F322	Motor: Unrecovered Negative regulator fault
F324	Motor: Unrecovered Module overtemp error
F326	Motor: Unrecovered 12V or 5V OK error
F328	Motor: Unrecovered unknown error
F32A	Motor: Unrecovered VCM DAC watchdog error
F332	Motor: Invalid standby RPM request
F334	Motor: Invalid spin state request
F336	Motor: Hardware retract timeout
F338	Motor: Unrecovered thermal limit exceeded
F33A	Motor: Predriver fault
F33C	Motor: Unrecovered Predriver Watchdog Fsys error
F33E	Motor: Unrecovered Predriver Watchdog DAC error
F340	Motor: Unrecovered Predriver Speed Low error
F342	Motor: Unrecovered Predriver UV Vboost error
F344	Motor: Unrecovered Predriver NREG UV error
F346	Motor: Unrecovered Predriver Ext NPOR error
F348	Motor: Unrecovered Predriver Reg UV error
1401	Servo: Recovered Requested rezero head does not exist
F402	Servo: Unrecovered Requested rezero head does not exist

<b>UEC</b>	<b>Description</b>
1403	Servo: Recovered Back EMF movement in progress
F404	Servo: Unrecovered Back EMF movement in progress
1405	Servo: Recovered Back EMF timeout error
F406	Servo: Unrecovered Back EMF timeout error
1407	Servo: Recovered ADC conversion timeout
F408	Servo: Unrecovered ADC conversion timeout
1409	Servo: Recovered Load/unload calibration error
F40A	Servo: Unrecovered Load/unload calibration error
140B	Servo: Recovered Invalid 5 volts
F40C	Servo: Unrecovered Invalid 5 volts
140D	Servo: Recovered Invalid 12 volts
F40E	Servo: Unrecovered Invalid 12 volts
140F	Servo: Recovered Invalid harmonic requested
F410	Servo: Unrecovered Invalid harmonic requested
1411	Servo: Recovered Gain BEMF Calibration error
F412	Servo: Unrecovered Gain BEMF Calibration error
1413	Servo: Recovered VOFF BEMF calibration error
F414	Servo: Unrecovered VOFF BEMF calibration error
1415	Servo: Recovered Invalid temperature
F416	Servo: Unrecovered Invalid temperature
1417	Servo: Recovered Truncated rezero
F418	Servo: Unrecovered Truncated rezero
1419	Servo: Recovered Heads not loaded
F41A	Servo: Unrecovered Heads not loaded
141B	Servo: Recovered No seek complete
F41C	Servo: Unrecovered No seek complete
141D	Servo: Recovered Seek timeout
F41E	Servo: Unrecovered Seek timeout
141F	Servo: Recovered Seek error
F420	Servo: Unrecovered Seek error
1421	Servo: Recovered Track following error
F422	Servo: Unrecovered Track following error
1423	Servo: Recovered Track follow timeout
F424	Servo: Unrecovered Track follow timeout
1425	Servo: Recovered KT Seek out of range
F426	Servo: Unrecovered KT Seek out of range
1427	Servo: Recovered DAC Offset calibration error
F428	Servo: Unrecovered DAC Offset calibration error
1429	Servo: Recovered Load speed error
F42A	Servo: Unrecovered Load speed error
142B	Servo: Recovered RRO Calibration timeout

<b>UEC</b>	<b>Description</b>
F42C	Servo: Unrecovered RRO Calibration timeout
142D	Servo: Recovered ADC Calibration error
F42E	Servo: Unrecovered ADC Calibration error
142F	Servo: Recovered ADC Offset error
F430	Servo: Unrecovered ADC Offset error
1431	Servo: Recovered ADC Limit error
F432	Servo: Unrecovered ADC Limit error
1433	Servo: Recovered Balancer Resistance error
F434	Servo: Unrecovered Balancer Resistance error
1435	Servo: Recovered Balancer Resistance Limit error
F436	Servo: Unrecovered Balancer Resistance Limit error
1437	Servo: Recovered First Cylinder error
F438	Servo: Unrecovered First Cylinder error
1439	Servo: Recovered Valid Cylinder error
F43A	Servo: Unrecovered Valid Cylinder error
143B	Servo: Recovered ADC Saturation error
F43C	Servo: Unrecovered ADC Saturation error
143D	Servo: Recovered Latch Break timeout
F43E	Servo: Unrecovered Latch Break timeout
143F	Servo: Recovered MR Resistance out of range error
F440	Servo: Unrecovered MR Resistance out of range error
1441	Servo: Recovered VCM Retract error
F442	Servo: Unrecovered VCM Retract error
1443	Servo: Recovered Load Retry error
F444	Servo: Unrecovered Load Retry error
1445	Servo: Recovered DFT Sharp error
F446	Servo: Unrecovered DFT Sharp error
1447	Servo: Recovered Load/Unload state error
F448	Servo: Unrecovered Load/Unload state error
1449	Servo: Recovered TFCR out-of-range error
F44A	Servo: Unrecovered TFCR out-of-range error
144B	Servo: Recovered Measure GMR Timeout
F44C	Servo: Unrecovered Measure GMR Timeout
144D	Servo: Recovered Coil Resistance Measurement Failure
F44E	Servo: Unrecovered Coil Resistance Measurement Failure
144F	Servo: Recovered SHARP Parity Error
F450	Servo: Unrecovered SHARP Parity Error
1451	Servo: Recovered SHARP Parity Rate Error
F452	Servo: Unrecovered SHARP Parity Rate Error
1453	Servo: Recovered SHARP Decode Error
F454	Servo: Unrecovered SHARP Decode Error

<b>UEC</b>	<b>Description</b>
1455	Servo: Recovered SHARP Decode Rate Error
F456	Servo: Unrecovered SHARP Decode Rate Error
1457	Servo: Recovered SHARP Timeout Error
F458	Servo: Unrecovered SHARP Timeout Error
1459	Servo: Recovered SHARP Timeout Rate Error
F45A	Servo: Unrecovered SHARP Timeout Rate Error
145B	Servo: Recovered SHARP Other Error
F45C	Servo: Unrecovered SHARP Other Error
145D	Servo: Recovered SHARP Other Rate Error
F45E	Servo: Unrecovered SHARP Other Rate Error
145F	Servo: Recovered WCS Hang Error
F460	Servo: Unrecovered WCS Hang Error
1461	Servo: Recovered DFT Timeout Error
F462	Servo: Unrecovered DFT Timeout Error
1463	Servo: Recovered SDM Timeout Error
F464	Servo: Unrecovered SDM Timeout Error
1465	Servo: Recovered Velocity Error
F466	Servo: Unrecovered RRO Write Error
F468	Servo: Unrecovered Velocity Error
F470	Servo: Unrecovered VCM Free Speed Error
F472	Servo: Unrecovered Emergency Brake Timeout
F474	Servo: Unrecovered Excessive Current Error
F476	Servo: Unrecovered Excessive Velocity Error
146F	Servo: Recovered VCM Free Speed Error
1471	Servo: Recovered Emergency Brake Timeout Error
1473	Servo: Recovered Excessive Current Error
1475	Servo: Recovered Excessive Velocity Error
F501	Logical unit not ready
F502	Logical unit becoming ready
F503	Logical unit not ready - initializing command required
F504	Not ready - format in progress
F505	Not ready - self-test in progress
F506	Reassign failed
F507	Format failed
F50D	Phy Test Function in Progress
F511	Illegal Request Sequence Error
F512	Invalid Message
F514	Not ready to ready transition
F515	Login reset (FC-AL only)

<b>UEC</b>	<b>Description</b>
F516	Power on reset
F517	LIP reset (FC-AL), SAS Hard Reset (SAS)
F518	Target Reset (FC-AL), LUN Reset (SAS)
F519	Self initiated reset
F51C	Mode parameters changed
F51D	Log parameters changed
F51E	Reservations pre-empted
F51F	Reservations released
F520	Registrations pre-empted
F521	Commands cleared by another initiator
F522	Microcode changed
F523	Inquiry parameters changed
F52D	Buffer CRC error on read
F52E	Internal target failure
F534	Overlapped command attempted
F535	Miscompare during verify
F536	Reservation conflict
F537	Device identifier changed
F539	ESI: unspecified failure (FC-AL only)
F53A	ESI: unsupported function (FC-AL only)
F53B	ESI: enclosure unavailable (FC-AL only)
F53C	ESI: transfer failure (FC-AL only)
F53E	Data phase error
F53F	Abort by LIP (FC-AL), Abort by OOB (SAS)
F544	Echo buffer overwritten
F549	LA Check error
F548	Device Control Hard Reset received
F54A	Xfer Ready credit exceeded (FC-AL only)
F54B	Transfer length error (FC-AL only)
F54E	Data Phase CRC Error
F550	NAK rcvd (SAS)
F551	ACK NAK Timeout (SAS)
F552	Bad parameter offset (SAS)
F553	LUN Not ready, Notify (Enable Spinup) required (SAS)
F554	I_T_Nexus Loss Occurred (SAS)
F555	Initiator Response Timeout (SAS)
F556	ESI transfer failed - write ack (FC-AL)
F557	ESI transfer failed - read ack (FC-AL)
F558	ESI transfer failed - write ready (FC-AL)
F559	ESI transfer failed - read ready (FC-AL)
F55A	ESI transfer refused - write ack (FC-AL)

<b>UEC</b>	<b>Description</b>
F55B	ESI transfer refused - read ack (FC-AL)
F55C	ESI transfer refused - write ready (FC-AL)
F55D	ESI transfer refused - read ready (FC-AL)
F55E	ESI transfer failed - EDV (FC-AL)
F560	Too much write data (SAS)
F561	Information unit too short (SAS)
F562	Information unit too long (SAS)
F567	Insufficient registration resources
F568	End-to-End Data Protection Guard check
F569	End-to-End Data Protection Application Tag check
F56A	End-to-End Data Protection Reference Tag check
F56B	ECC error in DRAM customer data area
F56C	Uncorrectable DRAM ECC error
F56F	Log dump data memory error
F570	Host interface Synchronous CRC error
F572	LUN not ready; manual intervention required
F573	Commands cleared due to power failure event (SAS)
F574	Host interface unsupported hardware
F579	ESI Transfer Checksum Error (FC-AL)
F57A	ESI Transfer Checksum Ready Timeout (FC-AL)
F57B	Host Interface Synchronous CRC LBA Error
1601	Channel/AE internal logic error
F602	Channel/AE hard logic error
F603	Channel/AE target failure
F604	Channel/AE calibration error
F605	Channel/AE MR Calibration Error
1606	Recovered AE last data read error
F607	Unrecovered data with PPM or precomp load
1616	Recovered channel error
F617	Unrecovered channel error
1618	Recovered AE thermal asperity found
F619	Unrecovered AE thermal asperity found
161A	Recovered AE open MR element error
F61B	Unrecovered AE open MR element error
161C	Recovered AE IC over temperature error
F61D	Unrecovered AE IC over temperature error
161E	Recovered AE IP clock count error
F61F	Unrecovered AE IP clock count error
1620	Recovered AE high MR current error
F621	Unrecovered AE high MR current error

<b>UEC</b>	<b>Description</b>
1622	Recovered AE write data BLS error
F623	Unrecovered AE write data BLS error
1624	Recovered AE invalid head address error
F625	Unrecovered AE invalid head address error
1626	Recovered AE power supply error
F627	Unrecovered AE power supply error
F629	Unrecovered AE open write head error
162A	Recovered AE write transition error
F62B	Unrecovered AE write transition error
162C	Recovered AE no write head current error
F62D	Unrecovered AE no write head current error
162E	Recovered Channel Pre-TA error
F62F	Unrecovered Channel NRZ Clear time out
F631	Unrecovered Channel write or NRZ parity error
F633	Unrecovered Channel Write Synth Unlock error
1634	Recovered AE Short write read head error
F635	Unrecovered AE Short write read head error
1636	Recovered AE Short write head error
F637	Unrecovered AE Short write head error
1638	Recovered AE Non-selected write head error
F639	Unrecovered AE Non-selected write head error
163A	Recovered AE Write current in read error
F63B	Unrecovered AE Write current in read error
163C	Recovered AE IH Open short error
F63D	Unrecovered AE IH Open short error
163E	Recovered AE IH Deleay error
F63F	Unrecovered AE IH Deleay error
1640	Recovered AE Write head encode error
F641	Unrecovered AE Write head encode error
1642	Recovered AE Readback error
F643	Unrecovered AE Readback error
1644	Recovered AE XSDEN Low during write error
F645	Unrecovered Channel coarse tune timeout
1646	Recovered AE Write Gate during Idle Fault
F647	Unrecovered AE Write Gate during Idle Fault
1648	Recovered Channel Reset Flag Error
F649	Unrecovered Channel Frequency Change Error
164A	Recovered Channel Split Fault Error
F64B	Unrecovered Channel Write Auxiliary Error
164C	Recovered Channel Sector Size Fault Error
F64D	Unrecovered Channel Write Invalid Error

<b>UEC</b>	<b>Description</b>
164E	Recovered Channel Last Split Fault Error
F64F	Unrecovered Channel Parity Pulse Error
1650	Recovered Channel Servo Servo Overlap Error
F651	Unrecovered Channel PLL Error
1652	Recovered Channel Read Gate Fault Error
F653	Unrecovered Channel Write Clock Error
1654	Recovered Channel RWBI Out Fault Error
F655	Unrecovered Channel PLL Write Safe Error
1656	Recovered Channel No Write Clock Error
F657	Unrecovered Channel No Write Clock Error
1658	Recovered Channel No NRZ Clock Error
F659	Unrecovered Channel No NRZ Clock Error
165A	Recovered Channel Cal Block Fault Error
F65B	Unrecovered Channel Cal Block Fault Error
165C	Recovered Channel Mode Overlap Fault Error
F65D	Unrecovered Channel Mode Overlap Fault Error
165E	Recovered Channel Preamble Fault Error
F65F	Unrecovered Channel Preamble Fault Error
1660	Recovered Channel WPLO Error
F661	Unrecovered Channel WPLO Error
1662	Recovered Channel Write Gate Overlap Fault Error
F663	Unrecovered Channel Write Gate Overlap Fault Error
1664	Recovered Channel Write Gate Fault Error
F665	Unrecovered Channel Write Gate Fault Error
1666	Recovered Channel Buffer Overflow Write Error
F667	Unrecovered Channel Buffer Overflow Write Error
1668	Recovered Channel Buffer Overflow Write Error
F669	Unrecovered Channel Buffer Overflow Write Error
166A	Recovered Channel Write Parity Error
F66B	Unrecovered Channel Write Parity Error
166C	Recovered Channel Buffer Overflow Write Error
F66D	Unrecovered Channel Buffer Overflow Write Error
166E	Recovered Channel Buffer Underflow Write Error
F66F	Unrecovered Channel Buffer Underflow Write Error
1670	Recovered Channel RPLO Late Error
F671	Unrecovered Channel RPLO Late Error
1672	Recovered Channel Bit Count Late Error
F673	Unrecovered Channel Bit Count Late Error
1676	Recovered Channel Pfault Read Error
F677	Unrecovered Channel Pfault Read Error
1678	Recovered Channel Pfault Write Error



<b>UEC</b>	<b>Description</b>
F679	Unrecovered Channel Pfault Write Error
167A	Recovered Channel Last Data Fault Error
F67B	Unrecovered Channel Last Data Fault Error
167C	Recovered Channel WRPO Fault Error
F67D	Unrecovered Channel WRPO Fault Error
1680	Recovered Channel PLLFloor Error
F681	Unrecovered Channel PLLFloor Error
1682	Recovered Channel Losslock Error
F683	Unrecovered Channel Losslock Error
1684	Recovered Channel VGA Floor Error
F685	Unrecovered Channel VGA Floor Error
1686	Recovered Channel Buffer EVGA Floor Error
F687	Unrecovered Channel Buffer EVGA Floor Error
1688	Recovered Channel TA Detector Error
F689	Unrecovered Channel TA Detector Error
168D	Unrecovered Channel ZGR Flag Error
F689	Unrecovered Channel TA Detector Error
F68F	Unrecovered Channel DPLL Freq Flag Error
168E	Recovered Channel DPLL Freq Flag Error
1694	Recovered Channel Flaw Sig Sync Error
F695	Unrecovered Channel Flaw Sig Sync Error
1696	Recovered Channel ACQ Flag Error
F697	Unrecovered Channel ACQ Flag Error
1698	Recovered Channel No Clock Error
F699	Unrecovered Channel No Clock Error
169A	Recovered Channel PLL Losslock Error
F69B	Unrecovered Channel PLL Losslock Error
169C	Recovered AE TFC Short Error
F69D	Unrecovered AE TFC Short Error
169E	Recovered AE MR Element Short Error
F69F	Unrecovered AE MR Element Short Error
F701	Format corrupted
F702	Too many notches
1703	Auto-reallocated due to write error
1704	Recommend reassign due to write error
D705	Media error with correction - reassigned
E706	Media error with correction - recommend reassign
E707	Media error with correction - recommend rewrite
E708	Media error with correction - rewritten
E70E	Recovered Data Address Mark error - rewritten
E70F	Recovered Data Address Mark error - recommend rewrite

<b>UEC</b>	<b>Description</b>
D710	Recovered Data Address Mark error - reassigned
E711	Recovered Data Address Mark error - recommend reassign
1712	Recovered MEDC error
F713	Unrecovered LBA MEDC error
1714	Recovered sector overflow
F715	Unrecovered sector overflow
1716	Recovered write overrun
F717	Unrecovered write overrun
1718	Recovered abort immediate
F719	Unrecovered abort immediate
171A	Recovered MEDC overrun
F71B	Unrecovered MEDC overrun
171C	Recovered DRAM CRC error
F71D	Unrecovered DRAM CRC error
171E	Recovered ID Parity error
F71F	Unrecovered ID Parity error
1722	Recovered small thermal asperity
F723	Unrecovered small thermal asperity
E728	Recovered thermal asperity - rewritten
E729	Recovered thermal asperity - recommend rewrite
E72A	Recovered thermal asperity - recommend reassign
D72B	Recovered thermal asperity - reassigned
172C	Recovered media error
F72D	Unrecovered media error
172E	Recovered media error (off-line correction discarded)
F72F	Unrecovered media error (off-line correction discarded)
F730	Recommend targeted scan
F731	Recovered Write Fault
F732	Unrecovered Write Fault
1735	Recovered data address mark error HDC
F736	Unrecovered data address mark error Channel
1737	Recovered post write abort
F738	Unrecovered post write abort
1739	Recovered Post PES check write abort
F73A	Unrecovered Post PES check write abort
173B	Recovered data address mark error Channel
F73C	Unrecovered data address mark error HDC
173D	Recovered sector miss
F73E	Unrecovered sector miss
F741	MEDIA OCT TIMEOUT NOT DISPATCHED
F742	MEDIA OCT TIMEOUT IN RECOVERY

<b>UEC</b>	<b>Description</b>
F743	MEDIA OCT TIMEOUT EXECUTING
1746	Defect list format not supported
1747	Primary defect list not found
1748	Grown defect list not found
1749	Partial defect list transferred
F74A	Sudden stop interrupt
F74B	Primary defect list error
F74C	Grown defect list error
F74D	Too many heads
F74E	Skew table size error
F74F	Too many zones
F750	Too many SIDs
F751	Alternate track table full
F752	Drive capacity too small
F753	G-list full (Format command)
F754	G-list full (2) (Format command)
F755	Pointer repeat size error
F756	DST slot size error
F757	P-list full
F758	Spare list full
1759	Unknown recovered error
F75A	Unknown unrecovered error
F75B	Too many sectors
F75C	Internal media access timeout
F75D	Selftest failed
F75E	Max servo cylinder too small
F761	Read/write command timeout
F762	Cache test fail
F763	OTF cache fail
1764	Correctable media error (embedded DAM only)
F765	Uncorrectable media error (embedded DAM only)
1766	Recovered Media LBA MEDC error
F767	Unrecovered Media LBA MEDC error
176A	Recovered No NRZ clock error
F76B	Unrecovered No NRZ clock error
176C	Media: Soft MEDC Correctable
F76D	Media: Hard MEDC Uncorrectable
176E	Media: Soft Chan RDY Error
F76F	Media: Hard Chan RDY Error
1770	Recovered SID timeout
F771	Unrecovered SID timeout

<b>UEC</b>	<b>Description</b>
F772	DASH starting timeout
F773	ID table timeout
F774	Servo timeout
F775	Buffers timeout
F776	DASH done timeout
F777	DASH unknown timeout
F77A	Unrecovered channel SBW timeout
F77B	Unrecovered Abort EOS fail
F77E	MEDIA WRITE ERROR RECOVERY TIMEOUT
F77F	MEDIA READ ERROR RECOVERY TIMEOUT
1778	MEDIA: Soft LBA FIFO Error
F779	MEDIA: Hard LBA FIFO Error
1782	MEDIA: Force Soft Error
F783	MEDIA: Hard Force Soft Error
1784	MEDIA: Soft CHN Sect Marginal
F785	MEDIA: Hard CHN Sect Marginal
1786	Recovered Soft LLI Underrun
F787	Unrecovered LLI Underrun error
F788	Media Hard SAT FIFO Underrun
F789	Media Hard SAT FIFO Overrun
F78A	Media Hard SAT SCT Overrun
F78B	Media Hard SAT Xfer End Mismatch
F78C	Media Hard SAT DMA Data not Rdy
F78D	Media Hard SAT General Err
F78E	Media Hard SAT Chan Rdy Err
1792	Recovered MEDC Write Data Not Ready Error
F793	Unrecovered MEDC WrdData Not Ready error
1794	Recovered Drive DMA timeout error
F795	Unrecovered Drive DMA timeout error
1798	Recovered ID not found error
F799	Unrecovered ID Not Found error
179C	Recovered Channel Channel Read Timeout Error
F79D	Unrecovered Channel Read Timeout error
17A9	Recovered read overrun
F7AA	Unrecovered read overrun
F7A8	Unrecovered marginal data address mark error Channel
17B2	Recovered abort window error
F7B3	Unrecovered abort window error
17B4	Recovered shock sensor error
F7B5	Unrecovered shock sensor error
F7B7	Recovered Write compare error

<b>UEC</b>	<b>Description</b>
F7B9	Unrecovered Reference tag error
F7BB	Unrecovered Application tag error
F7BD	Unrecovered Channel write synthesis unlock error
F7C1	Unrecovered End sector check error
17C2	Recovered Read CRC error
F7C3	Unrecovered Read CRC error
17C4	Recovered DRAM ECC error
F7C5	Unrecovered DRAM ECC error
17C6	Recovered DRAM ECC LBA error
F7C7	Unrecovered DRAM ECC LBA error
F7CC	Unrecovered LBA write uncorrectable error
F7CD	LBA encryption error
F7CE	Unrecovered Media Offline Already TAR error
F7D0	Pre-load timeout
17D6	Recovered read/write abort offtrack
17D8	Recovered r/w abort rro field misread
F7D9	Unrecovered r/w abort rro field misread
17DA	Servo Recovered read/write abort rro field misread
F7DB	Unrecovered r/w abort rro missing
17DC	Servo Recovered read/write abort rro field missing
F7DD	Unrecovered r/w abort idle seek
17DE	Servo Recovered read/write abort seek timeout
F7DF	Unrecovered r/w abort seek timeout
1737	Recovered post write abort
F738	Unrecovered post write abort
1739	Recovered Post PES check write abort
F73A	Unrecovered Post PES check write abort
17D6	Servo Recovered read/write abort offtrack
17D8	Servo Recovered read/write abort rro field missing
17DA	Servo Recovered read/write abort rro field misread
17DC	Servo Recovered read/write abort rro field missing
17DE	Servo Recovered read/write abort seek timeout
17E0	Servo Recovered read/write abort estimator error
F7E1	Servo Unrecovered read/write abort estimator error
17E2	Servo Recovered read/write abort predictor error
F7E3	Servo Unrecovered read/write abort predictor error
17E4	Servo Recovered read/write abort PES error
F7E5	Servo Unrecovered read/write abort PES error
17E6	Servo Recovered read/write abort seek start error
F7E7	Servo Unrecovered read/write abort seek start error

<b>UEC</b>	<b>Description</b>
17E8	Servo Recovered read/write abort PES reset error
F7E9	Servo Unrecovered read/write abort PES reset error
17EA	Servo Recovered read/write abort abort WCS other error
F7EB	Servo Unrecovered read/write abort SID unlock error
17EC	Servo Recovered read/write abort WCS other error
F7ED	Servo Unrecovered read/write abort WCS other error
17EE	Servo Recovered read/write abort hard reset
F7EF	Servo Unrecovered read/write abort hard reset
17F0	Servo Recovered read/write abort RV sensor error
F7F1	Servo Unrecovered read/write abort RV sensor error
17F2	Servo Recovered read/write abort RV sensor error
F7F3	Servo Unrecovered read/write abort RV sensor error
17F4	Servo Recovered read/write abort SHARP other error
F7F5	Servo Unrecovered read/write abort SHARP other error
17F6	Servo Recovered read/write abort SHARP exception error
F7F7	Servo Unrecovered read/write abort SHARP exception error
17F8	Servo Recovered read/write abort SVGA limit error
F7F9	Servo Unrecovered read/write abort SVGA limit error
17FA	Servo Recovered read/write abort gray code error
F7FB	Servo Unrecovered read/write abort gray code error
17FC	Servo Recovered read/write abort burst error
F7FD	Servo Unrecovered read/write abort burst error
17FE	Servo Recovered read/write abort no STM error
F7FF	Servo Unrecovered read/write abort no STM error
F820	Parameter list length error
F821	Invalid opcode in CDB
F822	LBA out of range
F823	Illegal request - invalid field in CDB
F824	Invalid LUN
F825	Illegal request - invalid field in parameter list
F826	Illegal request - Unsupported Log Page
F828	Illegal request – Invalid Release of Persistent Reservation
F830	Illegal Request Sequence error
1831	Power mode Idle_A by timer
1832	Power mode Idle_B by timer
1833	Power mode Idle_C by timer
1834	Power mode Standby_Z by timer
1835	Power mode Idle_A by command
1836	Power mode Idle_B by command
1837	Power mode Idle_C by command

<b>UEC</b>	<b>Description</b>
1839	Power mode Standby_Z by command
1839	Power mode Standby_Y by timer
183A	Power mode Standby_Y by command
2A01	SMART: Power On Hour Warning Recovered
1A02	SMART: Temperature warning (no sense)
2A02	SMART: Temperature warning (recovered sense)
3A02	SMART: Unit Attention Temperature
1A03	SMART: Background selftest warning (no sense)
2A03	SMART: Unit Attention Background selftest failure
3A03	SMART: Background selftest warning (unit attn sense)
1A04	SMART: Background Pre-Scan warning (no sense)
2A04	SMART: Background Pre-Scan warning (recovered sense)
3A04	SMART: Unit Attention - Background pre-scan failure
1A05	SMART: Background Media Scan warning (no sense)
2A05	SMART: Background Media Scan warning (recovered sense)
3A05	SMART: Unit Attention - Background media scan failure
1A14	SMART: Spare sector availability warning (no sense)
2A14	SMART: Spare sector availability warning (recovered sense)
3A14	SMART: Spare sector availability warning (unit attn sense)
1A21	SMART: Milliactuator Err (no sense)
2A21	SMART: Milliactuator Err (recovered sense)
3A21	SMART: Milliactuator Err (unit attention sense)
1A22	SMART: Extreme over temperature reached (no sense)
2A22	SMART: Extreme over temperature reached (recovered sense)
3A22	SMART: Extreme over temperature reached (unit attention sense)
1A32	SMART: Read error rate warning (no sense)
2A32	SMART: Read error rate warning (recovered sense)
3A32	SMART: Read error rate warning (unit attn sense)
1A43	SMART: Seek error rate warning (no sense)
2A43	SMART: Seek error rate warning (recovered sense)
3A43	SMART: Seek error rate warning (unit attn sense)
1A4A	SMART: Write error rate warning (no sense)
2A4A	SMART: Write error rate warning (recovered sense)
3A4A	SMART: Write error rate warning (unit attn sense)
1A50	SMART: Load/unload cycle count warning (no sense)
2A50	SMART: Load/unload cycle count warning (recovered sense)
3A50	SMART: Load/unload cycle count warning (unit attn sense)
1A56	SMART: Spin up time warning (no sense)
2A56	SMART: Spin up time warning (recovered sense)
3A56	SMART: Spin up time warning (unit attn sense)
1A5B	SMART: Spin up retry count warning (no sense)

UEC	Description
2A5B	SMART: Spin up retry count warning (recovered sense)
3A5B	SMART: Spin up retry count warning (unit attn sense)
1AFE	SMART: Thermal Sense trip (no sense)
2AFE	SMART: Extreme over-temperature warning
3AFE	SMART: Unrecovered Flash Scan Error
1AFF	SMART: Test warning (no sense)
2AFF	SMART: Test warning (recovered sense)
3AFF	SMART: Test warning (unit attn sense)
FCxx	Unable to read RID or FID number xx



## A

Abbreviations .....	69
Acoustics .....	39
Active Notch .....	143
Actuator .....	5
Additional information .....	255
Additional Sense Length (Byte 7) .....	286
Address Frames .....	53
Alternate Sectors per Zone .....	135
Alternate Tracks per Logical Unit .....	135
Alternate Tracks per Zone .....	135
Appendix .....	313
Automatic Read Reallocation Enabled .....	130
Automatic Rewrite/Reallocate .....	267
Automatic Write Reallocation Enabled .....	130
Average latency .....	11

## B

Block Descriptor .....	125
block format .....	74
buffer overrun .....	117
buffer underrun .....	117
Byte ordering conventions .....	69
bytes from index format .....	75

## C

Caution .....	1
Command Information Unit .....	59
Command Processing During Execution of Active I/O process .....	256
Command Processing During Startup and Format Operations .....	258
Command processing while reserved .....	265
Command Queuing .....	266
Command queuing .....	266
Command Reordering .....	266
Command reordering .....	266
Command Time out Limits .....	272
Concurrent I/O Process .....	266
Control Electronics .....	5
Cooling requirements .....	23
Corrosion test .....	22

## D

DATA Information Units .....	62
Data Integrity .....	15
Data Recovery Procedure .....	275
Data Reliability .....	29
Data Sheet .....	7
Data transfer speed .....	13
DC Power Requirements .....	25
Defect Descriptor .....	73
defect descriptor .....	73
defect list .....	72
Deferred Error Condition .....	258
Degraded Mode .....	259
device cache fast writes .....	118
device cache partial read hits .....	118
device cache write hits .....	118
Diagnostics .....	270
Disable Block Descriptor .....	123
Download Microcode and Save (Mode 0101b) .....	247
Drive Characteristics .....	7
Drive Mounting .....	35
Drive ready time .....	12
Drive Service Strategy .....	275

## E

Electrical Interface .....	19
Electromagnetic Compatibility .....	43
Environment .....	21
Equipment errors .....	29
Equipment Status .....	15
European Standards Compliance .....	45

## F

Failure prediction (PFA/S.M.A.R.T) .....	29
FC-AL attachment .....	47
FC-AL Connector .....	19
Flammability .....	45
Format Time .....	273
FORMAT UNIT .....	70
format unit .....	70

Formatted Capacity .....	7
Fundamentals .....	47

## G

German Safety Mark .....	45
Glossary .....	1
Grown Defect List (Glist) .....	183

## H

Hard Reset .....	51
Head Disk Assembly .....	5

## I

Identification .....	41
Idle Time Function .....	272
IEEE registered name format .....	49
Incorrect Length Indicator (Bit 5 of byte 2) .....	284
inquiry .....	77
Interface Connector .....	31, 32
Internal Error Condition .....	258

## L

Labels .....	41
Link Layer .....	53
Link Reset Sequence .....	50
Log Page Parameters .....	95
LOG SELECT .....	92
LOG SELECT (4C) .....	92
LOG SENSE .....	95
LOG SENSE (4D) .....	95
Logical Block Cache Segment Size .....	140

## M

Maximum Burst Size .....	134, 135
Maximum Pre-fetch .....	40
Maximum Pre-fetch Ceiling .....	140

Mechanical positioning .....	10
Mechanical Specifications .....	31
Merge G-List into P-List .....	128
Minimum Pre-fetch .....	140
Mode Pages .....	269
MODE SELECT .....	121, 122
MODE SELECT (15) .....	121
MODE SELECT (55) .....	122
MODE SENSE (1A) .....	123
MODE SENSE (5A) .....	155
Multiple Initiator Environment .....	269
Multiple Initiator Systems .....	268
multiple initiator systems .....	268

## N

Node and Port names .....	48
node name .....	48
Non-operating shock .....	38
Non-operating Vibrations .....	37

## O

OPEN Address Frame .....	55
Operating shock .....	37
Operating Vibration .....	37
Outline .....	31
Outline of the Drive .....	3
overrun counter .....	118
Overview .....	268

## P

Packaging .....	22
Page Code Valid .....	192
Page Format .....	212
Parameter data for Read Keys .....	160
Parameter data for Read Reservations .....	161
Parameter list .....	165
Persistent Reservation .....	159
PERSISTENT RESERVE IN (5E) .....	159
PERSISTENT RESERVE OUT 163, .....	167
PERSISTENT RESERVE OUT (5F) .....	163, 167

Persistent Reserve Out Parameter list .....	165
PHY Error Handling .....	53
PHY Layer .....	50
Physical Format .....	17
physical sector format .....	76
Physical Sector Format (101b) .....	186
Post Error .....	131
Predictive Failure Analysis .....	282
PRE-FETCH .....	167
Preventive Maintenance .....	30
Primary Defect List .....	183
Priority Commands .....	266
Priority commands .....	266
Product ID .....	8

## Q

Queue Depth .....	266
Queue Full Status .....	266

## R

Random Vibration .....	37
READ (10) - (28) .....	170
Read Ahead .....	268
READ BUFFER (3C) .....	176
Read Buffer Full Ratio .....	134
Read Cache Disable .....	140
READ CAPACITY .....	180
READ CAPACITY command .....	180
Read Continuous .....	130
READ DEFECT DATA (37) .....	183
READ DEFECT DATA (B7) .....	187
READ LONG command .....	189
Read Retry Count .....	131
REASSIGN BLOCKS (07) .....	190
Reassignment Time .....	273
RECEIVE DIAGNOSTICS (1C) .....	192
Recommended Initiator ERP .....	274
RELEASE (17) .....	195
RELEASE (57) .....	196
Reliability .....	29
REPORT LUNS (A0) .....	205
Report Recovered Non Data Errors .....	128

REQUEST SENSE (03) .....	207
RESERVE (16) .....	208
RESERVE (56) .....	209
Reserved Area .....	193
Reset .....	269
Reset Actions .....	269
Reset Sources .....	269
RESPONSE Information Units .....	62
REZERO UNIT (01) .....	210
Ripple Voltage .....	28

## S

S.M.A.R.T .....	29
Safety .....	45
SAS Attachment .....	47
SAS Features .....	47
SAS OOB .....	51
SAS OOB (Out of Band) .....	51
SAS Speed Negotiation .....	52
SCSI Command Set .....	67
SCSI Control Byte .....	69
SCSI Protocol .....	255
SCSI Sense Data .....	283
SCSI Sense Data Format .....	283
SCSI Status Byte .....	253
SCSI Status Byte Reporting .....	255
Sectors per Track .....	136
SEEK (10) - (2B) .....	211
SEEK (6) - (0B) .....	211
seek counter .....	117
Seek errors .....	29
seeks .....	118
Segmented Caching .....	268
SEND DIAGNOSTIC (1D) .....	212
Sense Data .....	269
sense data .....	269
Sense Data Description .....	284
Sense Key (Bit 3 - 0 of byte 2) .....	285
SenseData .....	283
Service Action .....	159, 164
Size Enable .....	139
Sound power levels .....	39
Spin up .....	49
Spindle stop time .....	12

START STOP UNIT (1B) .....	220
Start/Stop Cycles .....	29
Storage requirements .....	22
Storage time .....	22
Summary .....	166
Swept Sine Vibration .....	37
SYNCHRONIZE CACHE (35) .....	222

## T

Temperature and humidity .....	21
Temperature Threshold .....	129
Termination of I/O Processes .....	266
TEST UNIT READY (00) .....	224
Track Skew Factor .....	136
Tracks per Zone .....	136
Transfer Block .....	130
Transport Layer .....	57
Type .....	164

## U

UEC list .....	313
UL and CSA Standard Conformity .....	45
underrun counter .....	118
Unit Attention Condition .....	256, 280
unit attention condition .....	256
Unit Start/Stop Time .....	273

## V

Verify .....	281
VERIFY (2F) .....	225
Vibration and Shock .....	37

## W

WRITE (10) - (2A) .....	233
WRITE (6) - (0A) .....	232
WRITE AND VERIFY (2E) .....	240, 242
WRITE BUFFER (3B) .....	248
Write Buffer Empty Ratio .....	134

Write Cache .....	267
Write Cache Enable .....	139
WRITE LONG (3F) .....	249
Write Retention Priority .....	140
Write Retry Count .....	131
WRITE SAME (41) .....	251

## X

XFER_RDY Information Units .....	61
----------------------------------	----

## Z

zero seeks .....	118
------------------	-----

### A

Abbreviations	69
Acoustics	39
Active Notch	143
Actuator	5
Additional information	255
Additional Sense Length (Byte 7)	285
Address Frames	53
Alternate Sectors per Zone	135
Alternate Tracks per Logical Unit	135
Alternate Tracks per Zone	135
Appendix	311
Automatic Read Reallocation Enabled	130
Automatic Rewrite/Reallocate	267
Automatic Write Reallocation Enabled	130
Average latency	11

### B

Block Descriptor	125
block format	74
buffer overrun	117
buffer underrun	117
Byte ordering conventions	69
bytes from index format	75

### C

Caution	1
Command Information Unit	59
Command Processing During Execution of Active I/O process	256
Command Processing During Startup and Format Operations	258
Command processing while reserved	265
Command Queuing	266



- Command queuing 266
- Command Reordering 266
- Command reordering 266
- Command Time out Limits 272
- Concurrent I/O Process 266
- Control Electronics 5
- Cooling requirements 23
- Corrosion test 22
- D
- DATA Information Units 62
- Data Integrity 15
- Data Recovery Procedure 275
- Data Reliability 29
- Data Sheet 7
- Data transfer speed 13
- DC Power Requirements 25
- Defect Descriptor 73
- defect descriptor 73
- defect list 72
- Deferred Error Condition 258
- Degraded Mode 259
- device cache fast writes 118
- device cache partial read hits 118
- device cache write hits 118
- Diagnostics 270
- Disable Block Descriptor 123
- Download Microcode and Save (Mode 0101b) 245
- Drive Characteristics 7
- Drive Mounting 35
- Drive ready time 12
- Drive Service Strategy 275
- E
- Electrical Interface 19
- Electromagnetic Compatibility 43
- Environment 21
- Equipment errors 29
- Equipment Status 15
- European Standards Compliance 45
- F
- Failure prediction (PFA/S.M.A.R.T) 29
- FC-AL attachment 47
- FC-AL Connector 19
- Flammability 45
- Format Time 273
- FORMAT UNIT 70
- format unit 70

Formatted Capacity 7  
Fundamentals 47  
G  
German Safety Mark 45  
Glossary 1  
Grown Defect List (Glist) 181  
H  
Hard Reset 51  
Head Disk Assembly 5  
I  
Identification 41  
Idle Time Function 272  
IEEE registered name format 49  
Incorrect Length Indicator (Bit 5 of byte 2) 284  
inquiry 77  
Interface Connector 31, 32  
Internal Error Condition 258  
L  
Labels 41  
Link Layer 53  
Link Reset Sequence 50  
Log Page Parameters 95  
LOG SELECT 92  
LOG SELECT (4C) 92  
LOG SENSE 95  
LOG SENSE (4D) 95  
Logical Block Cache Segment Size 140  
M  
Maximum Burst Size 134, 135  
Maximum Pre-fetch 140  
Maximum Pre-fetch Ceiling 140  
Mechanical positioning 10  
Mechanical Specifications 31  
Merge G-List into P-List 128  
Minimum Pre-fetch 140  
Mode Pages 269  
MODE SELECT 121, 122  
MODE SELECT (15) 121  
MODE SELECT (55) 122  
MODE SENSE (1A) 123  
MODE SENSE (5A) 155  
Multiple Initiator Environment 269  
Multiple Initiator Systems 268  
multiple initiator systems 268  
N  
Node and Port names 48

- node name 48
- Non-operating shock 38
- Non-operating Vibrations 37
- O
- OPEN Address Frame 55
- Operating shock 37
- Operating Vibration 37
- Outline 31
- Outline of the Drive 3
- overrun counter 118
- Overview 268
- P
- Packaging 22
- Page Code Valid 190
- Page Format 210
- Parameter data for Read Keys 158
- Parameter data for Read Reservations 159
- Parameter list 163
- Persistent Reservation 157
- PERSISTENT RESERVE IN (5E) 157
- PERSISTENT RESERVE OUT 161, 165
- PERSISTENT RESERVE OUT (5F) 161, 165
- Persistent Reserve Out Parameter list 163
- PHY Error Handling 53
- PHY Layer 50
- Physical Format 17
- physical sector format 76
- Physical Sector Format (101b) 184
- Post Error 131
- Predictive Failure Analysis 282
- PRE-FETCH 165
- Preventive Maintenance 30
- Primary Defect List 181
- Priority Commands 266
- Priority commands 266
- Product ID 8
- Q
- Queue Depth 266
- Queue Full Status 266
- R
- Random Vibration 37
- READ (10) - (28) 168
- Read Ahead 268
- READ BUFFER (3C) 174
- Read Buffer Full Ratio 134
- Read Cache Disable 140

READ CAPACITY 178  
READ CAPACITY command 178  
Read Continuous 130  
READ DEFECT DATA (37) 181  
READ DEFECT DATA (B7) 185  
READ LONG command 187  
Read Retry Count 131  
REASSIGN BLOCKS (07) 188  
Reassignment Time 273  
RECEIVE DIAGNOSTICS (1C) 190  
Recommended Initiator ERP 274  
RELEASE (17) 193  
RELEASE (57) 194  
Reliability 29  
REPORT LUNS (A0) 203  
Report Recovered Non Data Errors 128  
REQUEST SENSE (03) 205  
RESERVE (16) 206  
RESERVE (56) 207  
Reserved Area 191  
Reset 269  
Reset Actions 269  
Reset Sources 269  
RESPONSE Information Units 62  
REZERO UNIT (01) 208  
Ripple Voltage 28  
S  
S.M.A.R.T 29  
Safety 45  
SAS Attachment 47  
SAS Features 47  
SAS OOB 51  
SAS OOB (Out of Band) 51  
SAS Speed Negotiation 52  
SCSI Command Set 67  
SCSI Control Byte 69  
SCSI Protocol 255  
SCSI Sense Data 283  
SCSI Sense Data Format 283  
SCSI Status Byte 253  
SCSI Status Byte Reporting 255  
Sectors per Track 136  
SEEK (10) - (2B) 209  
SEEK (6) - (0B) 209  
seek counter 117  
Seek errors 29

seeks 118  
Segmented Caching 268  
SEND DIAGNOSTIC (1D) 210  
Sense Data 269  
sense data 269  
Sense Data Description 283  
Sense Key (Bit 3 - 0 of byte 2) 284  
SenseData 283  
Service Action 157, 162  
Size Enable 139  
Sound power levels 39  
Spin up 49  
Spindle stop time 12  
START STOP UNIT (1B) 218  
Start/Stop Cycles 29  
Storage requirements 22  
Storage time 22  
Summary 164  
Swept Sine Vibration 37  
SYNCHRONIZE CACHE (35) 220  
T  
Temperature and humidity 21  
Temperature Threshold 129  
Termination of I/O Processes 266  
TEST UNIT READY (00) 222  
Track Skew Factor 136  
Tracks per Zone 136  
Transfer Block 130  
Transport Layer 57  
Type 162  
U  
UEC list 311  
UL and CSA Standard Conformity 45  
underrun counter 118  
Unit Attention Condition 256, 280  
unit attention condition 256  
Unit Start/Stop Time 273  
V  
Verify 281  
VERIFY (2F) 223  
Vibration and Shock 37  
W  
WRITE (10) - (2A) 231  
WRITE (6) - (0A) 230  
WRITE AND VERIFY (2E) 238, 240  
WRITE BUFFER (3B) 246

Write Buffer Empty Ratio 134  
Write Cache 267  
Write Cache Enable 139  
WRITE LONG (3F) 247  
Write Retention Priority 140  
Write Retry Count 131  
WRITE SAME (41) 249  
X  
XFER\_RDY Information Units 61  
Z  
zero seeks 118



© Copyright HGST, a Western Digital company

HGST, a Western Digital company  
3403 Yerba Buena Road  
San Jose, CA 95135  
Produced in the United States  
Tel: 800-801-4618 Fax: 408-717-5000

03 September 2013

All rights reserved Ultrastar™ is a trademark of HGST.

HGST trademarks are authorized for use in countries and jurisdictions in which HGST has the right to use, market and advertise the brands. HGST shall not be liable to third parties for unauthorized use of HGST trademarks.

Microsoft, Windows XP, and Windows are trademarks of Microsoft Corporation in the United States, other countries, or both.

Other trademarks are the property of their respective owners.

References in this publication to HGST products, programs or services do not imply that HGST intends to make these available in all countries in which HGST operates.

Product information is provided for information purposes only and does not constitute a warranty.

Information is true as of the date of publication and is subject to change. Actual results may vary. This publication is for general guidance only. Photographs may show design models.

This publication is for general guidance only. Photographs may show design models