

Operating Instructions

Levelflex FMP51, FMP52, FMP54

HART

Guided wave radar

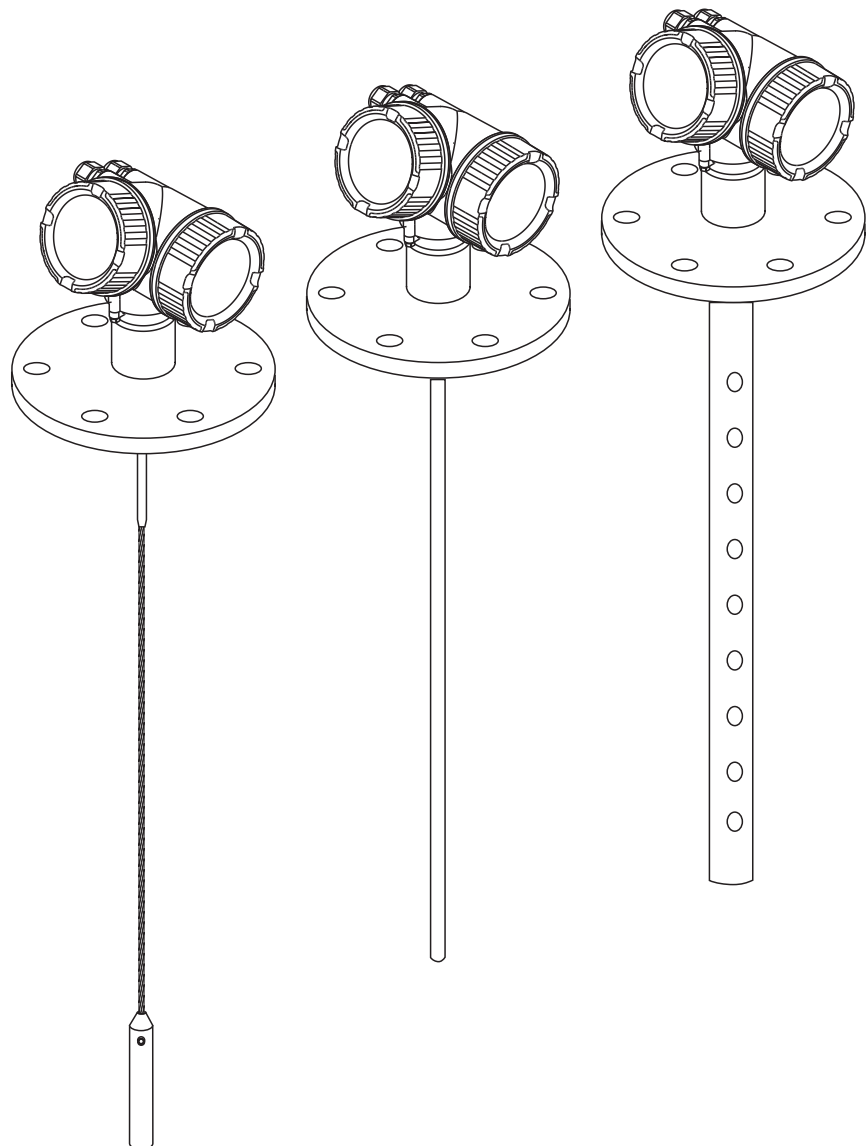

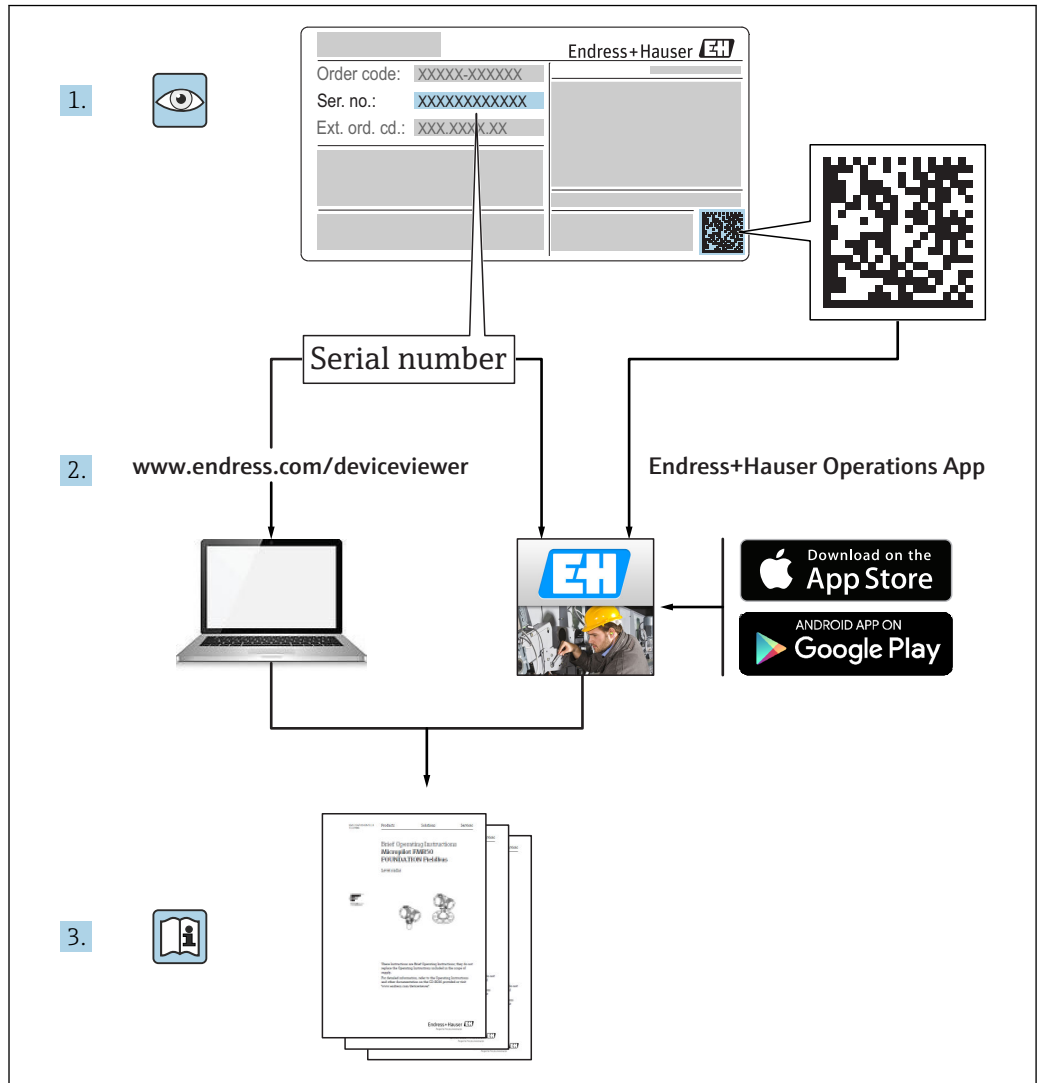

A0023555

Table of contents

1	Important document information	5	6.2	Mounting the device	47
1.1	Document function	5	6.2.1	Required mounting tools	47
1.2	Symbols	5	6.2.2	Shortening the probe	47
1.2.1	Safety symbols	5	6.2.3	FMP54 with gas phase compensation: Mounting the probe rod	49
1.2.2	Electrical symbols	5	6.2.4	Mounting the device	50
1.2.3	Tool symbols	5	6.2.5	Mounting the "Sensor remote" version	51
1.2.4	Symbols for certain types of information	6	6.2.6	Turning the transmitter housing	53
1.2.5	Symbols in graphics	6	6.2.7	Turning the display module	53
1.2.6	Symbols at the device	7	6.3	Post-installation check	54
1.3	Supplementary documentation	8	7	Electrical connection	55
1.3.1	Safety Instructions (XA)	9	7.1	Connection conditions	55
2	Basic safety instructions	13	7.1.1	Terminal assignment	55
2.1	Requirements for personnel	13	7.1.2	Cable specification	61
2.2	Designated use	13	7.1.3	Device plug connectors	62
2.3	Workplace safety	14	7.1.4	Power supply	63
2.4	Operational safety	14	7.1.5	Overvoltage protection	65
2.5	Product safety	14	7.2	Connecting the device	65
2.5.1	CE mark	14	7.2.1	Pluggable spring-force terminals	66
2.5.2	EAC conformity	14	7.3	Post-connection check	67
3	Product description	15	8	Operation options	68
3.1	Product design	15	8.1	Overview	68
3.1.1	Levelflex FMP51/FMP52/FMP54/FMP55	15	8.1.1	Local operation	68
3.1.2	Electronics housing	16	8.1.2	Operation with remote display and operating module FHX50	68
3.2	Registered trademarks	17	8.1.3	Remote operation	69
4	Incoming acceptance and product identification	18	8.2	Structure and function of the operating menu	70
4.1	Incoming acceptance	18	8.2.1	Structure of the operating menu	70
4.2	Product identification	18	8.2.2	User roles and related access authorization	71
4.2.1	Nameplate	19	8.2.3	Write protection via access code	72
5	Storage, Transport	20	8.2.4	Disabling write protection via access code	73
5.1	Storage conditions	20	8.2.5	Deactivation of the write protection via access code	73
5.2	Transport product to the measuring point	20	8.2.6	Write protection via write protection switch	74
6	Mounting	21	8.2.7	Enabling and disabling the keypad lock	76
6.1	Mounting requirements	21	8.3	Display and operating module	77
6.1.1	Suitable mounting position	21	8.3.1	Display appearance	77
6.1.2	Applications with restricted mounting space	23	8.3.2	Operating elements	80
6.1.3	Notes on the mechanical load of the probe	25	8.3.3	Entering numbers and text	81
6.1.4	Notes on the process connection	27	8.3.4	Opening the context menu	83
6.1.5	Mounting cladded flanges	32	8.3.5	Envelope curve on the display and operating module	84
6.1.6	Securing the probe	33			
6.1.7	Special mounting conditions	36			

9	Device integration via the HART protocol	85	14	Repairs	111
9.1	Overview of the Device Description files (DD)	85	14.1	General information on repairs	111
9.2	HART device variables and measuring values	85	14.1.1	Repair concept	111
10	Commissioning via wizard	86	14.1.2	Repairs to Ex-approved devices	111
11	Commissioning via operating menu	87	14.1.3	Replacement of an electronics module	111
11.1	Installation and function check	87	14.1.4	Replacement of a device	111
11.2	Setting the operating language	87	14.2	Spare parts	112
11.3	Checking the reference distance	87	14.3	Return	112
11.4	Configuration of a level measurement	89	14.4	Disposal	112
11.5	Configuration of an interface measurement	91	15	Accessories	113
11.6	Recording the reference curve	93	15.1	Device-specific accessories	113
11.7	Configuration of the on-site display	94	15.1.1	Weather protection cover	113
11.7.1	Factory settings of the on-site display for level measurements	94	15.1.2	Mounting bracket for the electronics housing	114
11.7.2	Factory settings of the on-site display for interface measurements	94	15.1.3	Extension rod / centering HMP40	115
11.7.3	Adjustment of the on-site display	94	15.1.4	Mounting kit, isolated	116
11.8	Configuration of the current outputs	95	15.1.5	Centering star	117
11.8.1	Factory setting of the current outputs for level measurements	95	15.1.6	Remote display FHX50	119
11.8.2	Factory setting of the current outputs for interface measurements	95	15.1.7	Overvoltage protection	120
11.8.3	Adjustment of the current outputs	95	15.2	Communication-specific accessories	121
11.9	Configuration management	96	15.3	Service-specific accessories	122
11.10	Protection of the settings against unauthorized changes	97	15.4	System components	122
12	Diagnostics and troubleshooting	98	16	Operating menu	123
12.1	General trouble shooting	98	16.1	Overview of the operating menu (display module)	123
12.1.1	General errors	98	16.2	Overview of the operating menu (operating tool)	131
12.1.2	Parametrization errors	99	16.3	"Setup" menu	138
12.2	Diagnostic information on local display	101	16.3.1	"Mapping" wizard	151
12.2.1	Diagnostic message	101	16.3.2	"Advanced setup" submenu	152
12.2.2	Calling up remedial measures	103	16.4	"Diagnostics" menu	207
12.3	Diagnostic event in the operating tool	104	16.4.1	"Diagnostic list" submenu	209
12.4	Diagnostic list	104	16.4.2	"Event logbook" submenu	210
12.5	List of diagnostic events	105	16.4.3	"Device information" submenu	211
12.6	Event logbook	107	16.4.4	"Measured values" submenu	214
12.6.1	Event history	107	16.4.5	"Data logging" submenu	218
12.6.2	Filtering the event logbook	107	16.4.6	"Simulation" submenu	221
12.6.3	Overview of information events	107	16.4.7	"Device check" submenu	226
12.7	Firmware history	109	Index	228	
13	Maintenance	110			
13.1	Exterior cleaning	110			





1 Important document information

1.1 Document function







These Operating Instructions contain all the information that is required in various phases of the life cycle of the device: from product identification, incoming acceptance and storage, to mounting, connection, operation and commissioning through to troubleshooting, maintenance and disposal.

1.2 Symbols



1.2.1 Safety symbols



Symbol	Meaning
	DANGER! This symbol alerts you to a dangerous situation. Failure to avoid this situation will result in serious or fatal injury.
	WARNING! This symbol alerts you to a dangerous situation. Failure to avoid this situation can result in serious or fatal injury.
	CAUTION! This symbol alerts you to a dangerous situation. Failure to avoid this situation can result in minor or medium injury.
	NOTE! This symbol contains information on procedures and other facts which do not result in personal injury.

1.2.2 Electrical symbols





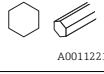





Symbol	Meaning	Symbol	Meaning
	Direct current		Alternating current
	Direct current and alternating current		Ground connection A grounded terminal which, as far as the operator is concerned, is grounded via a grounding system.
	Protective ground connection A terminal which must be connected to ground prior to establishing any other connections.		Equipotential connection A connection that has to be connected to the plant grounding system: This may be a potential equalization line or a star grounding system depending on national or company codes of practice.

1.2.3 Tool symbols



Symbol	Meaning
 A0013442	Torx screwdriver
 A0011220	Flat blade screwdriver

Symbol	Meaning
 A0011219	Cross-head screwdriver
 A0011221	Allen key
 A0011222	Hexagon wrench



1.2.4 Symbols for certain types of information

Symbol	Meaning
	Permitted Procedures, processes or actions that are permitted.
	Preferred Procedures, processes or actions that are preferred.
	Forbidden Procedures, processes or actions that are forbidden.
	Tip Indicates additional information.
	Reference to documentation
	Reference to page
	Reference to graphic
	Series of steps
	Result of a step
	Help in the event of a problem
	Visual inspection

1.2.5 Symbols in graphics

Symbol	Meaning
1, 2, 3 ...	Item numbers
	Series of steps
A, B, C, ...	Views
A-A, B-B, C-C, ...	Sections
	Hazardous area Indicates a hazardous area.
	Safe area (non-hazardous area) Indicates the non-hazardous area.

1.2.6 Symbols at the device

Symbol	Meaning
	Safety instructions Observe the safety instructions contained in the associated Operating Instructions.
	Temperature resistance of the connection cables Specifies the minimum value of the temperature resistance of the connection cables.

1.3 Supplementary documentation

Document	Purpose and content of the document
Technical Information TI01001F (FMP51, FMP52, FMP54)	Planning aid for your device The document contains all the technical data on the device and provides an overview of the accessories and other products that can be ordered for the device.
Brief Operating Instructions KA01077F (FMP51/FMP52/ FMP54, HART)	Guide that takes you quickly to the 1st measured value The Brief Operating Instructions contain all the essential information from incoming acceptance to initial commissioning.
Description of Device Parameters GP01000F (FMP5x, HART)	Reference for your parameters The document provides a detailed explanation of each individual parameter in the operating menu. The description is aimed at those who work with the device over the entire life cycle and perform specific configurations.

 For an overview of the scope of the associated Technical Documentation, refer to the following:

- The *W@M Device Viewer* : Enter the serial number from the nameplate (www.endress.com/deviceviewer)
- The *Endress+Hauser Operations App*: Enter the serial number from the nameplate or scan the 2-D matrix code (QR code) on the nameplate.

1.3.1 Safety Instructions (XA)

Depending on the approval, the following Safety Instructions (XA) are supplied with the device. They are an integral part of the Operating Instructions.

Feature 010	Approval	Available for	Feature 020: "Power Supply; Output"				
			A ¹⁾	B ²⁾	C ³⁾	E ⁴⁾ /G ⁵⁾	K ⁶⁾ /L ⁷⁾
BA	ATEX II 1G Ex ia IIC T6 Ga	<ul style="list-style-type: none"> ▪ FMP51 ▪ FMP52 ▪ FMP54 	XA00496F	XA01125F	XA01126F	XA00516F	-
BB	ATEX II 1/2G Ex ia IIC T6 Ga/Gb	<ul style="list-style-type: none"> ▪ FMP51 ▪ FMP52 ▪ FMP54 	XA00496F	XA01125F	XA01126F	XA00516F	-
BC	ATEX II 1/2G Ex d ia IIC T6 Ga/Gb	<ul style="list-style-type: none"> ▪ FMP51 ▪ FMP52 ▪ FMP54 	XA00499F	XA00499F	XA00499F	XA00519F	XA01133F
BD	ATEX II 1/3G Ex ic ia IIC T6 Ga/Gc	<ul style="list-style-type: none"> ▪ FMP51 ▪ FMP52 ▪ FMP54 	XA00497F	XA01127F	XA01128F	XA00517F	-
BE	ATEX II 1D Ex t IIIC Da	FMP54	XA00501F	XA00501F	XA00501F	XA00521F	XA00501F
BF	ATEX II 1/2D Ex t IIIC Da/Db	FMP54	XA00501F	XA00501F	XA00501F	XA00521F	XA00501F
BG	ATEX II 3G Ex nA IIC T6 Gc	<ul style="list-style-type: none"> ▪ FMP51 ▪ FMP52 ▪ FMP54 	XA00498F	XA01130F	XA01131F	XA00518F	XA01132F
BH	ATEX II 3G Ex ic IIC T6 Gc	<ul style="list-style-type: none"> ▪ FMP51 ▪ FMP52 ▪ FMP54 	XA00498F	XA01130F	XA01131F	XA00518F	-
BL	ATEX II 1/3G Ex nA ia IIC T6 Ga/Gc	<ul style="list-style-type: none"> ▪ FMP51 ▪ FMP52 ▪ FMP54 	XA00497F	XA01127F	XA01128F	XA00517F	XA01129F
B2	ATEX II 1/2G Ex ia IIC T6 Ga/Gb, 1/2D Ex ia IIIC Da/Db	<ul style="list-style-type: none"> ▪ FMP51 ▪ FMP52 ▪ FMP54 	XA00502F	XA00502F	XA00502F	XA00522F	-
B3	ATEX II 1/2G Ex d ia IIC T6 Ga/Gb, 1/2 D Ex t IIIC Da/Db	<ul style="list-style-type: none"> ▪ FMP51 ▪ FMP52 ▪ FMP54 	XA00503F	XA00503F	XA00503F	XA00523F	XA01136F
B4	ATEX II 1/2G Ex ia IIC T6 Ga/Gb, Ex d ia IIC T6 Ga/Gb	<ul style="list-style-type: none"> ▪ FMP51 ▪ FMP52 ▪ FMP54 	XA00500F	XA01134F	XA01135F	XA00520F	-
CD	CSA C/US DIP Cl.I,II,III Div.1 Gr.E-G	FMP54	XA00529F	XA00529F	XA00529F	XA00570F	XA00529F
C2	CSA C/US IS Cl.I,II,III Div.1 Gr.A-G, NI Cl.1 Div.2, Ex ia	<ul style="list-style-type: none"> ▪ FMP51 ▪ FMP52 ▪ FMP54 	XA00530F	XA00530F	XA00530F	XA00571F	XA00530F
C3	CSA C/US XP Cl.I,II,III Div.1 Gr.A-G, NI Cl.1 Div.2, Ex d	<ul style="list-style-type: none"> ▪ FMP51 ▪ FMP52 ▪ FMP54 	XA00529F	XA00529F	XA00529F	XA00570F	XA00529F
FB	FM IS Cl.I,II,III Div.1 Gr.A-G, AEx ia, NI Cl.1 Div.2	<ul style="list-style-type: none"> ▪ FMP51 ▪ FMP52 ▪ FMP54 	XA00531F	XA00531F	XA00531F	XA00573F	XA00531F
FD	FM XP Cl.I,II,III Div.1 Gr.A-G, AEx d, NI Cl.1 Div.2	<ul style="list-style-type: none"> ▪ FMP51 ▪ FMP52 ▪ FMP54 	XA00532F	XA00532F	XA00532F	XA00572F	XA00532F
FE	FM DIP Cl.I,II,III Div.1 Gr.E-G	FMP54	XA00532F	XA00532F	XA00532F	XA00572F	XA00532F
GA	EAC Ex ia IIC T6 Ga	<ul style="list-style-type: none"> ▪ FMP51 ▪ FMP52 ▪ FMP54 	XA01380F	XA01380F	XA01380F	XA01381F	XA01380F

Feature 010	Approval	Available for	Feature 020: "Power Supply; Output"				
			A ¹⁾	B ²⁾	C ³⁾	E ^{4)/G⁵⁾}	K ^{6)/L⁷⁾}
GB	EAC Ex ia IIC T6 Ga/Gb	<ul style="list-style-type: none"> ▪ FMP51 ▪ FMP52 ▪ FMP54 	XA01380F	XA01380F	XA01380F	XA01381F	XA01380F
GC	EAC Ex d[ia] IIC T6 Ga/Gb	<ul style="list-style-type: none"> ▪ FMP51 ▪ FMP52 ▪ FMP54 	XA01382F	XA01382F	XA01382F	XA01383F	XA01382F
IA	IEC Ex ia IIC T6 Ga	<ul style="list-style-type: none"> ▪ FMP51 ▪ FMP52 ▪ FMP54 	XA00496F	XA01125F	XA01126F	XA00516F	-
IB	IEC Ex ia IIC T6 Ga/Gb	<ul style="list-style-type: none"> ▪ FMP51 ▪ FMP52 ▪ FMP54 	XA00496F	XA01125F	XA01126F	XA00516F	-
IC	IEC Ex d[ia] IIC T6 Ga/Gb	<ul style="list-style-type: none"> ▪ FMP51 ▪ FMP52 ▪ FMP54 	XA00499F	XA00499F	XA00499F	XA00519F	XA01133F
ID	IEC Ex ic[ia] IIC T6 Ga/Gc	<ul style="list-style-type: none"> ▪ FMP51 ▪ FMP52 ▪ FMP54 	XA00497F	XA01127F	XA01128F	XA00517F	-
IE	IEC Ex t IIIC Da	FMP54	XA00501F	XA00501F	XA00501F	XA00521F	XA00501F
IF	IEC Ex t IIIC Da/Db	FMP54	XA00501F	XA00501F	XA00501F	XA00521F	XA00501F
IG	IEC Ex nA IIC T6 Gc	<ul style="list-style-type: none"> ▪ FMP51 ▪ FMP52 ▪ FMP54 	XA00498F	XA01130F	XA01131F	XA00518F	XA01132F
IH	IEC Ex ic IIC T6 Gc	<ul style="list-style-type: none"> ▪ FMP51 ▪ FMP52 ▪ FMP54 	XA00498F	XA01130F	XA01131F	XA00518F	-
IL	IEC Ex nA[ia] IIC T6 Ga/Gc	<ul style="list-style-type: none"> ▪ FMP51 ▪ FMP52 ▪ FMP54 	XA00497F	XA01127F	XA01128F	XA00517F	XA01129F
I2	IEC Ex ia IIC T6 Ga/Gb, Ex ia IIIC Da/Db	<ul style="list-style-type: none"> ▪ FMP51 ▪ FMP52 ▪ FMP54 	XA00502F	XA00502F	XA00502F	XA00522F	-
I3	IEC Ex d [ia] IIC T6 Ga/Gb, Ex t IIIC Da/Db	<ul style="list-style-type: none"> ▪ FMP51 ▪ FMP52 ▪ FMP54 	XA00503F	XA00503F	XA00503F	XA00523F	XA01136F
I4	IEC Ex II 1/2G Ex ia IIC T6 Ga/Gb, Ex d[ia] IIC T6 Ga/Gb	<ul style="list-style-type: none"> ▪ FMP51 ▪ FMP52 ▪ FMP54 	XA00500F	XA01134F	XA01135F	XA00520F	-
KA	KC Ex ia IIC T6 Ga	<ul style="list-style-type: none"> ▪ FMP51 ▪ FMP52 ▪ FMP54 	XA01169F	-	XA01169F	-	-
KB	KC Ex ia IIC T6 Ga/Gb	<ul style="list-style-type: none"> ▪ FMP51 ▪ FMP52 ▪ FMP54 	XA01169F	-	XA01169F	-	-
KC	KC Ex d[ia] IIC T6	<ul style="list-style-type: none"> ▪ FMP51 ▪ FMP52 ▪ FMP54 	-	-	XA01170F	-	-
MA	INMETRO Ex ia IIC T6 Ga	<ul style="list-style-type: none"> ▪ FMP51 ▪ FMP52 ▪ FMP54 	XA01038F	XA01038F	XA01038F	-	XA01038F
MC	INMETRO Ex d[ia] IIC T6 Ga/Gb	<ul style="list-style-type: none"> ▪ FMP51 ▪ FMP52 ▪ FMP54 	XA01041F	XA01041F	XA01041F	-	XA01041F
ME	INMETRO Ex t IIIC Da	FMP54	XA01043F	XA01043F	XA01043F	-	XA01043F

Feature 010	Approval	Available for	Feature 020: "Power Supply; Output"				
			A ¹⁾	B ²⁾	C ³⁾	E ⁴⁾ /G ⁵⁾	K ⁶⁾ /L ⁷⁾
MH	INMETRO Ex ic IIC T6 Gc	<ul style="list-style-type: none"> ▪ FMP51 ▪ FMP52 ▪ FMP54 	XA01040F	XA01040F	XA01040F	-	XA01040F
NA	NEPSI Ex ia IIC T6 Ga	<ul style="list-style-type: none"> ▪ FMP51 ▪ FMP52 ▪ FMP54 	XA00634F	XA00634F	XA00634F	XA00640F	XA00634F
NB	NEPSI Ex ia IIC T6 Ga/Gb	<ul style="list-style-type: none"> ▪ FMP51 ▪ FMP52 ▪ FMP54 	XA00634F	XA00634F	XA00634F	XA00640F	XA00634F
NC	NEPSI Ex d[ia] IIC T6 Ga/Gb	<ul style="list-style-type: none"> ▪ FMP51 ▪ FMP52 ▪ FMP54 	XA00636F	XA00636F	XA00636F	XA00642F	XA00636F
NF	NEPSI DIP A20/21 T85...90oC IP66	FMP54	XA00637F	XA00637F	XA00637F	XA00643F	XA00637F
NG	NEPSI Ex nA II T6 Gc	<ul style="list-style-type: none"> ▪ FMP51 ▪ FMP52 ▪ FMP54 	XA00635F	XA00635F	XA00635F	XA00641F	XA00635F
NH	NEPSI Ex ic IIC T6 Gc	<ul style="list-style-type: none"> ▪ FMP51 ▪ FMP52 ▪ FMP54 	XA00635F	XA00635F	XA00635F	XA00641F	XA00635F
N2	NEPSI Ex ia IIC T6 Ga/Gb, Ex iaD 20/21 T85...90°C	<ul style="list-style-type: none"> ▪ FMP51 ▪ FMP52 ▪ FMP54 	XA00638F	XA00638F	XA00638F	XA00644F	XA00638F
N3	NEPSI Ex d[ia] IIC T6 Ga/Gb, DIP A20/21 T85...90°C IP66	<ul style="list-style-type: none"> ▪ FMP51 ▪ FMP52 ▪ FMP54 	XA00639F	XA00639F	XA00639F	XA00645F	XA00639F
8A	FM/CSA IS+XP Cl.I,II,III Div.1 Gr.A-G	<ul style="list-style-type: none"> ▪ FMP51 ▪ FMP52 ▪ FMP54 	XA00531F XA00532F	XA00531F XA00532F	XA00531F XA00532F	XA00572F XA00573F	XA00531F XA00532F

- 1) A: 2-wire; 4-20mA HART
- 2) B: 2-wire; 4-20mA HART, switch output
- 3) C: 2-wire; 4-20mA HART, 4-20mA
- 4) E: 2-wire; FOUNDATION Fieldbus, switch output
- 5) G: 2-wire; PROFIBUS PA, switch output
- 6) K: 4-wire 90-253VAC; 4-20mA HART
- 7) L: 4-wire 10,4-48VDC; 4-20mA HART



For certified devices the relevant Safety Instructions (XA) are indicated on the nameplate.

Ex-marking in case of connected FHX50 remote display

If the device is prepared for the remote display FHX50 (product structure: feature 030: Display, Operation¹⁾, option L or M), the Ex marking of some certificates changes according to the following table¹⁾:

Feature 010 ("Approval")	Feature 030 ("Display, Operation")	Ex-marking
BE	L or M	ATEX II 1D Ex ta [ia] IIIC T ₅₀₀ xx°C Da
BF	L or M	ATEX II 1/2 D Ex ta [ia Db] IIIC Txx°C Da/Db
BG	L or M	ATEX II 3G Ex nA [ia Ga] IIC T6 Gc
BH	L or M	ATEX II 3G Ex ic [ia Ga] IIC T6 Gc
B3	L or M	ATEX II 1/2G Ex d [ia] IIC T6 Ga/Gb, ATEX II 1/2D Ex ta [ia Db] IIIC Txx°C Da/Db
IE	L or M	IECEX Ex ta [ia] IIIC T500 xx°C Da
IF	L or M	IECEX ta [ia Db] IIIC Txx°C Da/Db
IG	L or M	IECEX Ex nA [ia Ga] IIC T6 Gc
IH	L or M	IECEX Ex ic [ia Ga] IIC T6 Gc
I3	L or M	IECEX Ex d [ia] IIC T6 Ga/Gb, IECEX Ex ta [ia Db] IIIC Txx°C Da/Db

1) The marking of certificates not mentioned in this table are not affected by the FHX50.

2 Basic safety instructions

2.1 Requirements for personnel

The personnel for installation, commissioning, diagnostics and maintenance must fulfill the following requirements:

- ▶ Trained, qualified specialists must have a relevant qualification for this specific function and task.
- ▶ Are authorized by the plant owner/operator.
- ▶ Are familiar with federal/national regulations.
- ▶ Before starting work, read and understand the instructions in the manual and supplementary documentation as well as the certificates (depending on the application).
- ▶ Follow instructions and comply with basic conditions.

The operating personnel must fulfill the following requirements:

- ▶ Are instructed and authorized according to the requirements of the task by the facility's owner-operator.
- ▶ Follow the instructions in this manual.

2.2 Designated use

Application and measured materials

The measuring device described in these Operating Instructions is intended only for level and interface measurement of liquids. Depending on the version ordered the device can also measure potentially explosive, flammable, poisonous and oxidizing materials.

Observing the limit values specified in the "Technical data" and listed in the Operating Instructions and supplementary documentation, the measuring device may be used for the following measurements only:

- ▶ Measured process variable: Level and/or interface
- ▶ Calculated process variable: Volume oder mass in arbitrarily shaped vessels (calculated from the level by the linearization functionality)

To ensure that the measuring device remains in proper condition for the operation time:

- ▶ Use the measuring device only for measured materials against which the process-wetted materials are adequately resistant.
- ▶ Observe the limit values in "Technical data".

Incorrect use

The manufacturer is not liable for damage caused by improper or non-designated use.

Verification for borderline cases:

- ▶ For special measured materials and cleaning agents, Endress+Hauser is glad to provide assistance in verifying the corrosion resistance of wetted materials, but does not accept any warranty or liability.

Residual risk

The electronics housing and its built-in components such as display module, main electronics module and I/O electronics module may heat to 80 °C (176 °F) during operation through heat transfer from the process as well as power dissipation within the electronics. During operation the sensor may assume a temperature near the temperature of the measured material.

Danger of burns due to heated surfaces!

- ▶ For high process temperatures: Install protection against contact in order to prevent burns.

2.3 Workplace safety

For work on and with the device:

- ▶ Wear the required personal protective equipment according to federal/national regulations.

With divisible probe rods, medium may penetrate into the joints between the individual parts of the rod. This medium may escape when loosening the joints. In the case of dangerous (e.g. aggressive or toxic) media this may cause injuries.

- ▶ When loosening the joints between the individual parts of the probe rod: Wear appropriate protective equipment according to the medium.

2.4 Operational safety

Risk of injury.

- ▶ Operate the device in proper technical condition and fail-safe condition only.
- ▶ The operator is responsible for interference-free operation of the device.

Conversions to the device

Unauthorized modifications to the device are not permitted and can lead to unforeseeable dangers.

- ▶ If, despite this, modifications are required, consult with the manufacturer.

Repair

To ensure continued operational safety and reliability,

- ▶ Carry out repairs on the device only if they are expressly permitted.
- ▶ Observe federal/national regulations pertaining to repair of an electrical device.
- ▶ Use original spare parts and accessories from the manufacturer only.

Hazardous area

To eliminate a danger for persons or for the facility when the device is used in the hazardous area (e.g. explosion protection, pressure vessel safety):

- ▶ Based on the nameplate, check whether the ordered device is permitted for the intended use in the hazardous area.
- ▶ Observe the specifications in the separate supplementary documentation that is an integral part of these Instructions.

2.5 Product safety

This measuring device is designed in accordance with good engineering practice to meet state-of-the-art safety requirements, has been tested, and left the factory in a condition in which it is safe to operate. It meets general safety standards and legal requirements.

2.5.1 CE mark

The measuring system meets the legal requirements of the applicable EC guidelines. These are listed in the corresponding EC Declaration of Conformity together with the standards applied.

Endress+Hauser confirms successful testing of the device by affixing to it the CE mark.

2.5.2 EAC conformity

The measuring system meets the legal requirements of the applicable EAC guidelines. These are listed in the corresponding EAC Declaration of Conformity together with the standards applied.

Endress+Hauser confirms successful testing of the device by affixing to it the EAC mark.

3 Product description

3.1 Product design

3.1.1 Levelflex FMP51/FMP52/FMP54/FMP55

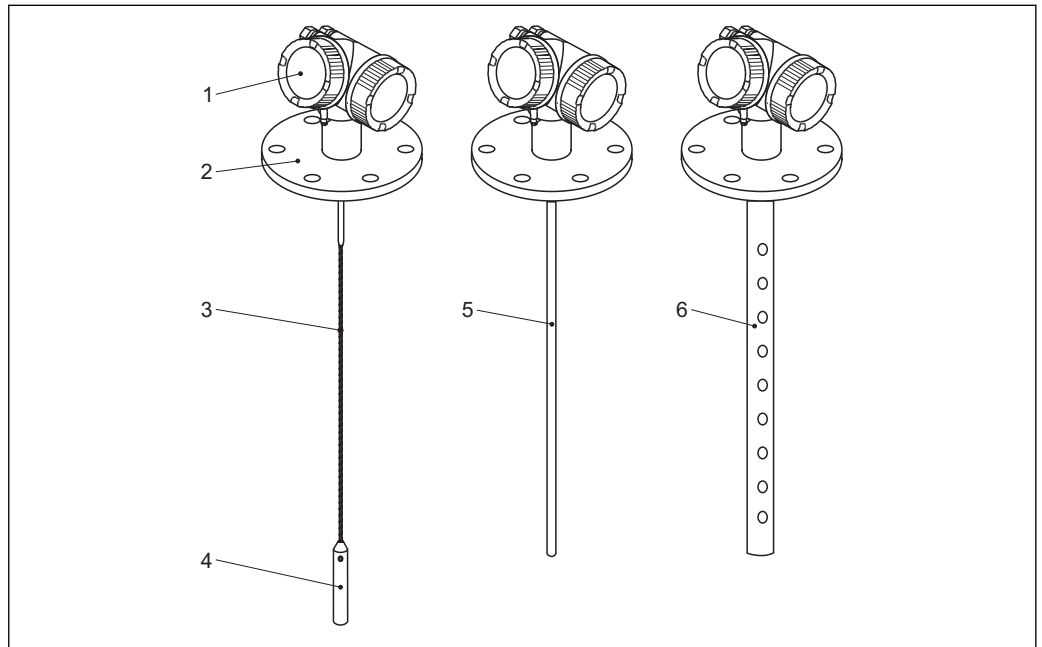

A0012399

1 Design of the Levelflex

- 1 Electronics housing
- 2 Process connection (here as an example: flange)
- 3 Rope probe
- 4 End-of-probe weight
- 5 Rod probe
- 6 Coax probe

3.1.2 Electronics housing

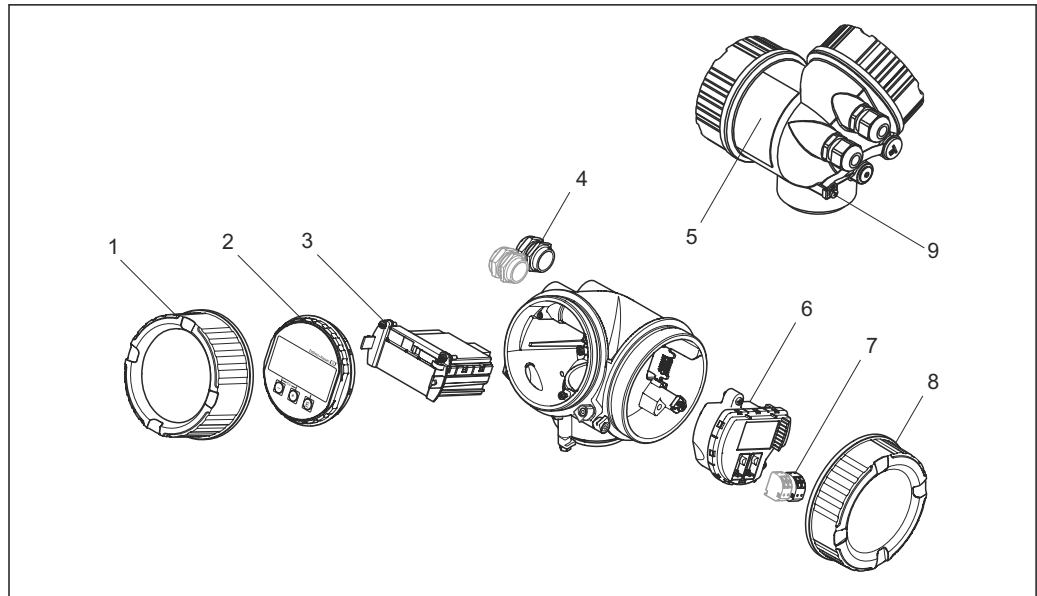

A0012422

2 Design of the electronics housing

- 1 Electronics compartment cover
- 2 Display module
- 3 Main electronics module
- 4 Cable glands (1 or 2, depending on instrument version)
- 5 Nameplate
- 6 I/O electronics module
- 7 Terminals (pluggable spring terminals)
- 8 Connection compartment cover
- 9 Grounding terminal

3.2 Registered trademarks

HART®

Registered trademark of the FieldComm Group, Austin, USA

KALREZ®, VITON®

Registered trademark of DuPont Performance Elastomers L.L.C., Wilmington, USA

TEFLON®

Registered trademark of E.I. DuPont de Nemours & Co., Wilmington, USA

TRI CLAMP®

Registered trademark of Alfa Laval Inc., Kenosha, USA

NORD-LOCK®

Registered trademark of the Nord-Lock International AB

4 Incoming acceptance and product identification

4.1 Incoming acceptance

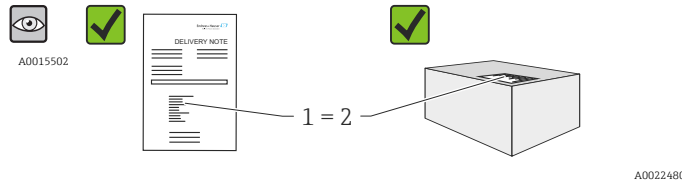

Is the order code on the delivery note (1) identical to the order code on the product sticker (2)?

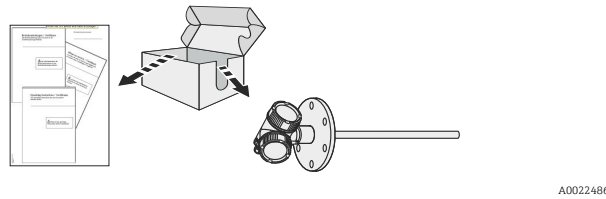

Are the goods undamaged?

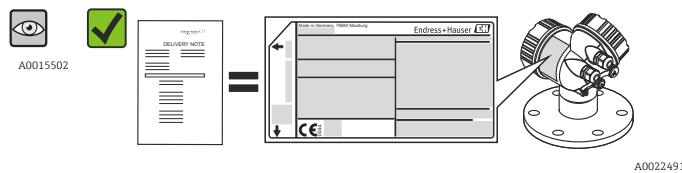

Do the nameplate data match the ordering information on the delivery note?

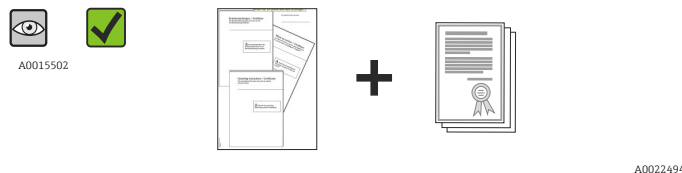

Is the DVD (operating tool) present?
If required (see nameplate): Are the Safety Instructions (XA) present?

i If one of the conditions does not comply, contact your Endress+Hauser distributor.

4.2 Product identification

The following options are available for identification of the measuring device:

- Nameplate specifications
- Order code with breakdown of the device features on the delivery note
- Enter serial numbers from nameplates in *W@M Device Viewer* (www.endress.com/deviceviewer): All information about the measuring device is displayed.
- Enter the serial number from the nameplates into the *Endress+Hauser Operations App* or scan the 2-D matrix code (QR code) on the nameplate with the *Endress+Hauser Operations App*: all the information for the measuring device is displayed.

4.2.1 Nameplate

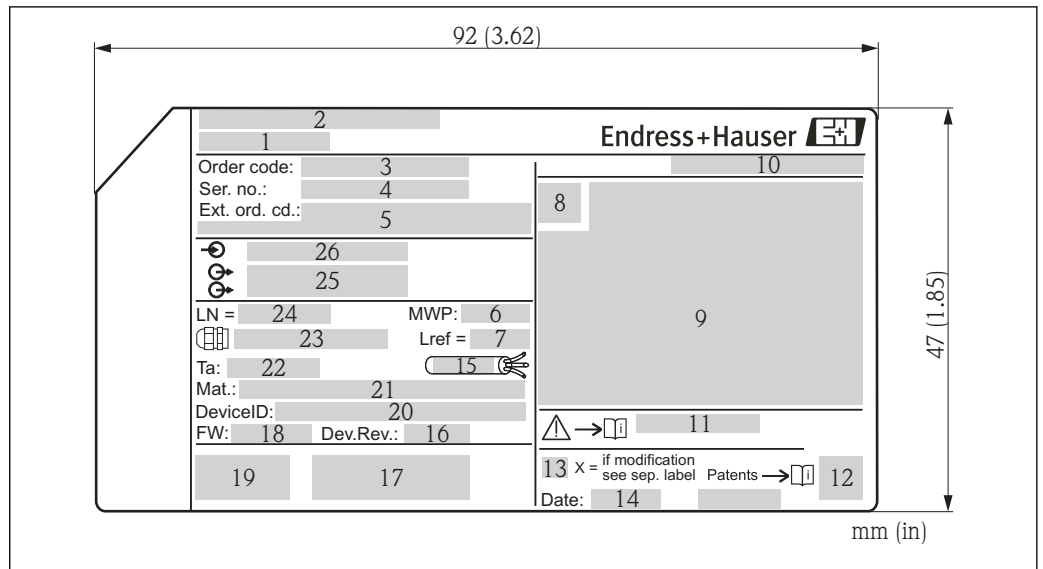

3 Nameplate of the Levelflex

- 1 Device name
- 2 Address of manufacturer
- 3 Order code
- 4 Serial number (Ser. no.)
- 5 Extended order code (Ext. ord. cd.)
- 6 Process pressure
- 7 Gas phase compensation: reference distance
- 8 Certificate symbol
- 9 Certificate and approval relevant data
- 10 Degree of protection: e.g. IP, NEMA
- 11 Document number of the Safety Instructions: e.g. XA, ZD, ZE
- 12 2-D matrix code (QR code)
- 13 Modification mark
- 14 Manufacturing date: year-month
- 15 Permitted temperature range for cable
- 16 Geräteversion (Dev.Rev.)
- 17 Additional information about the device version (certificates, approvals, communication): e.g. SIL, PROFIBUS
- 18 Firmware version (FW)
- 19 CE mark, C-Tick
- 20 DeviceID
- 21 Material in contact with process
- 22 Permitted ambient temperature (T_a)
- 23 Size of the thread of the cable glands
- 24 Length of probe
- 25 Signal outputs
- 26 Operating voltage

i Only 33 digits of the extended order code can be indicated on the nameplate. If the extended order code exceeds 33 digits, the rest will not be shown. However, the complete extended order code can be viewed in the operating menu of the device in the **Extended order code 1 to 3** parameter.

5 Storage, Transport

5.1 Storage conditions

- Permitted storage temperature: -40 to +80 °C (-40 to +176 °F)
- Use the original packaging.

5.2 Transport product to the measuring point

⚠ WARNING

Housing or probe may be damaged or break away.

Risk of injury!

- ▶ Transport the measuring device to the measuring point in its original packaging or at the process connection.
- ▶ Do not fasten lifting devices (hoisting slings, lifting eyes etc.) at the housing or the probe but at the process connection. Take into account the mass center of the device in order to avoid unintended tilting.
- ▶ Comply with the safety instructions, transport conditions for devices over 18kg (39.6lbs) (IEC61010).

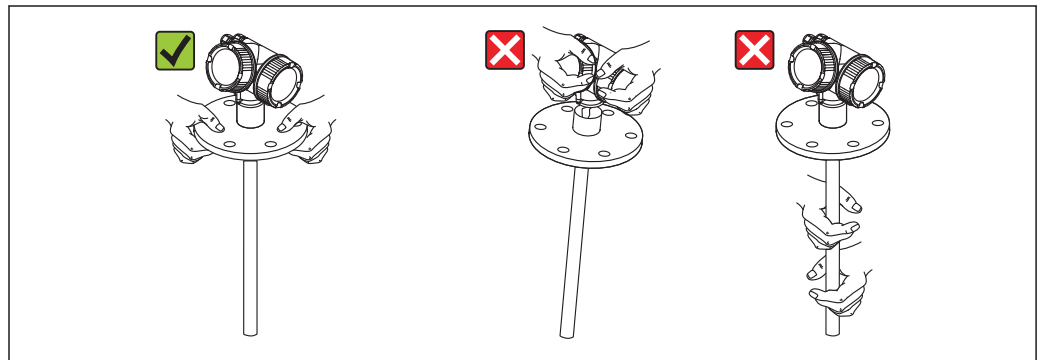

A0013920

6 Mounting

6.1 Mounting requirements

6.1.1 Suitable mounting position

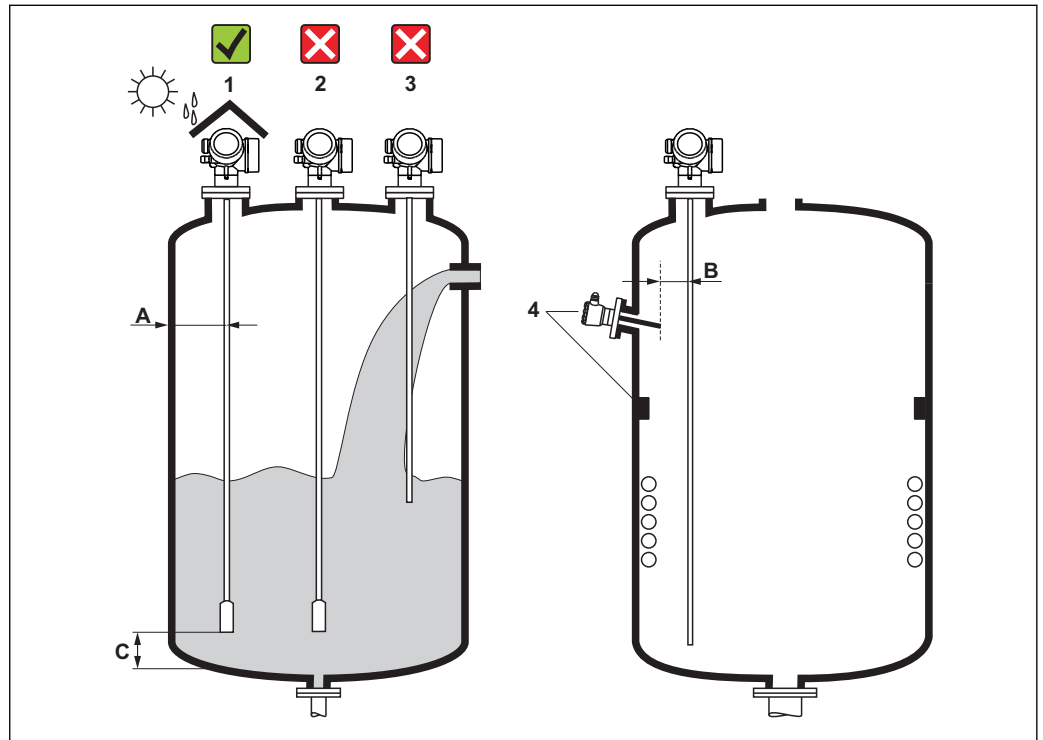

4 Mounting requirements for Levelflex

A0012606

Mounting distances

- Distance (A) between wall and rod or rope probe:
 - for smooth metallic walls: > 50 mm (2 in)
 - for plastic walls: > 300 mm (12 in) to metallic parts outside the vessel
 - for concrete walls: > 500 mm (20 in), otherwise the available measuring range may be reduced.
- Distance (B) between rod or rope probe and internal fittings in the vessel: > 300 mm (12 in)
- When using more than one Levelflex:
 - Minimum distance between the sensor axes: 100 mm (3.94 in)
- Distance (C) from end of probe to bottom of the vessel:
 - Rope probe: > 150 mm (6 in)
 - Rod probe: > 10 mm (0.4 in)
 - Coax probe: > 10 mm (0.4 in)

i For coax probes the distance to the wall and to internal fittings is arbitrary.

Additional conditions

- When mounting in the open, a weather protection cover (1) may be installed to protect the device against extreme weather conditions.
 - In metallic vessels: Preferably do not mount the probe in the center of the vessel (2), as this would lead to increased interference echoes.
If a central mounting position can not be avoided, it is crucial to perform an interference echo suppression(mapping) after the commissioning of the device.
 - Do not mount the probe in the filling curtain (3).
 - Avoid buckling the rope probe during installation or operation (e.g. through product movement against silo wall) by selecting a suitable mounting location.
- i** With suspended rope probes (probe end not fixed at the bottom) the distance between the probe rope and internal fittings in the tank must not fall below 300 mm (12") during the entire process. A sporadic contact between the probe weight and the cone of the vessel, however, does not influence the measurement as long as the dielectric constant of the medium is at least $DC = 1.8$.
- i** When mounting the electronics housing into a recess (e.g. in a concrete ceiling), observe a minimum distance of 100 mm (4 inch) between the cover of the terminal compartment / electronics compartment and the wall. Otherwise the connection compartment / electronics compartment is not accessible after installation.

6.1.2 Applications with restricted mounting space

Mounting with remote sensor

The device version with a remote sensor is suited for applications with restricted mounting space. In this case the electronics housing is mounted at a separate position from which it is easier accessible.

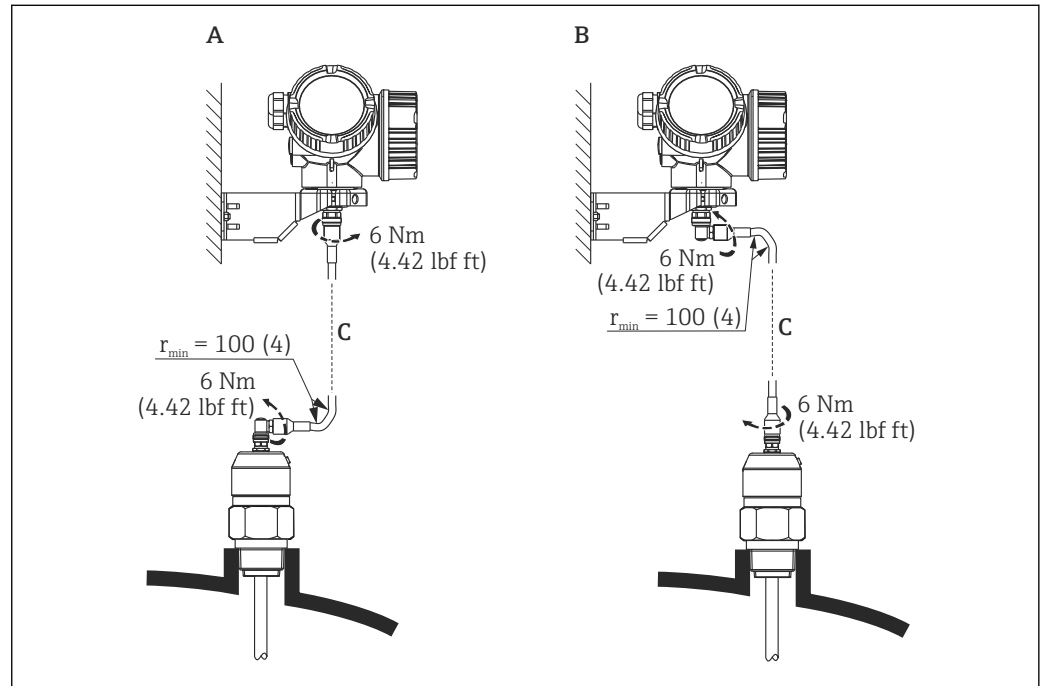

A0014794

- A Angled plug at the probe
 B Angled plug at the electronics housing
 C Length of the remote cable as ordered

- Product structure, feature 600 "Probe Design":
 - Option MB "Sensor remote, 3m/9ft cable"
 - Option MC "Sensor remote, 6m/18ft cable"
 - Option MB "Sensor remote, 9m/27ft cable"
 - The remote cable is supplied with these device versions
 Minimum bending radius: 100 mm (4 inch)
 - A mounting bracket for the electronics housing is supplied with these device versions.
 Mounting options:
 - Wall mounting
 - Pipe mounting; diameter: 42 to 60 mm (1-1/4 to 2 inch)
 - The connection cable has got one straight and one angled plug (90°). Depending on the local conditions the angled plug can be connected at the probe or at the electronics housing.
- i** Probe, electronics and connection cable are adjusted to match each other. They are marked by a common serial number. Only components with the same serial number shall be connected to each other.

Divisible probes

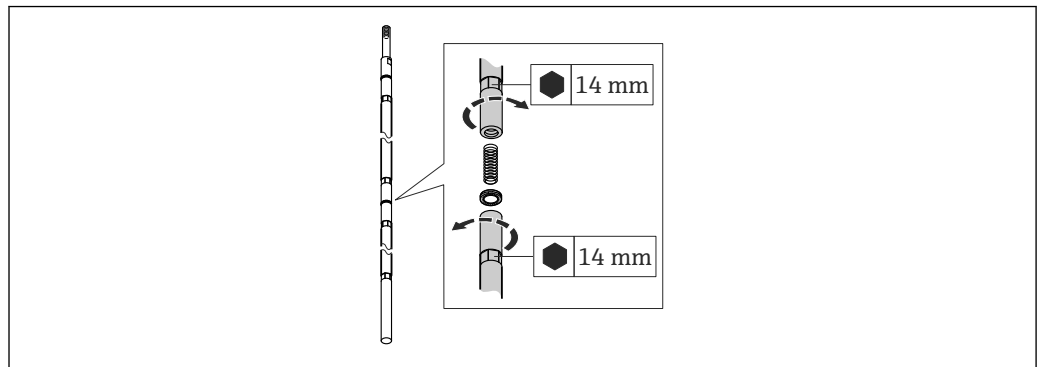

If there is little mounting space (distance to the ceiling), it is advisable to use divisible rod probes (ϕ 16 mm).

- max. probe length 10 m (394 in)
- max. sideways capacity 30 Nm
- probes are separable several times with the following lengths of the individual parts:
 - 500 mm (20 in)
 - 1 000 mm (40 in)
- torque: 15 Nm

6.1.3 Notes on the mechanical load of the probe

Tensile load limit of rope probes

Sensor	Feature 060	Probe	Tensile load limit [kN]
FMP51	LA, LB MB, MD	Rope 4mm (1/6") 316	5
FMP52	OA, OB, OC, OD	Rope 4mm (1/6") PFA>316	2
FMP54	LA, LB	Rope 4mm (1/6") 316	10

Bending strength of rod probes

Sensor	Feature 060	Probe	Bending strength [Nm]
FMP51	AA, AB	Rod 8mm (1/3") 316L	10
	AC, AD	Rod 12mm (1/2") 316L	30
	AL, AM	Rod 12mm (1/2") AlloyC	30
	BA, BB, BC, BD	Rod 16mm (0.63") 316L divisible	30
FMP52	CA, CB	Rod 16mm (0.63") PFA>316L	30
FMP54	AE, AF	Rod 16mm (0.63") 316L	30
	BA, BB, BC, BD	Rod 16mm (0.63") 316L divisible	30

Bending load (torque) through fluid flow

The formula for calculating the bending torque M impacting on the probe:

$$M = c_w \cdot \rho / 2 \cdot v^2 \cdot d \cdot L \cdot (L_N - 0.5 \cdot L)$$

with:

c_w : Friction factor

ρ [kg/m³]: Density of the medium

v [m/s]: Velocity of the medium perpendicular to the probe rod

d [m]: Diameter of the probe rod

L [m]: Level

L_N [m]: Probe length

Calculation example

Friction factor c_w 0,9 (on the assumption of a turbulent current - high Reynolds number)

Density ρ [kg/m³] 1000 (e.g. water)

Probe diameter d [m] 0,008

$L = L_N$ (worst case)

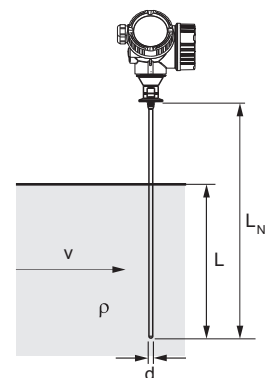

A0014175

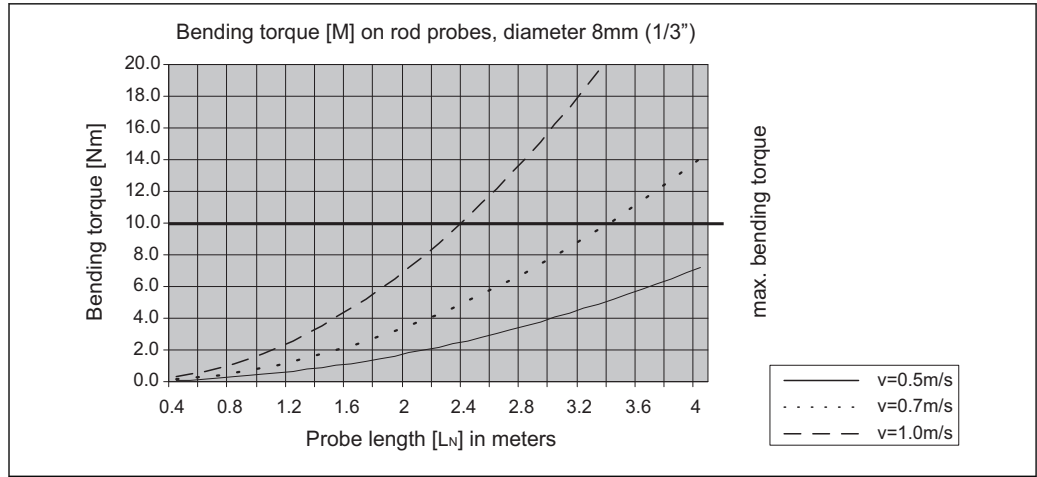

A0014182-EN

Bending strength of coax probes

Sensor	Feature 060	Process connection	Probe	Bending strength [Nm]
FMP51	UA, UB	Thread G $\frac{3}{4}$ oder NPT $\frac{3}{4}$	Coax 316L, Ø 21,3 mm	60
		<ul style="list-style-type: none"> ■ Thread G1$\frac{1}{2}$ or NPT1$\frac{1}{2}$ ■ Flange 	Coax 316L, Ø 42,4 mm	300
	UC, UD	Flange	Coax AlloyC, Ø 42,4 mm	300
FMP54	UA, UB	<ul style="list-style-type: none"> ■ Thread G1$\frac{1}{2}$ or NPT1$\frac{1}{2}$ ■ Flange 	Coax 316L, Ø 42,4 mm	300

6.1.4 Notes on the process connection

Probes are mounted to the process connection with threaded connections or flanges. If during this installation there is the danger that the probe end moves so much that it touches the tank floor or cone at times, the probe must, if necessary, be shortened and fixed down →  33.

Threaded connection

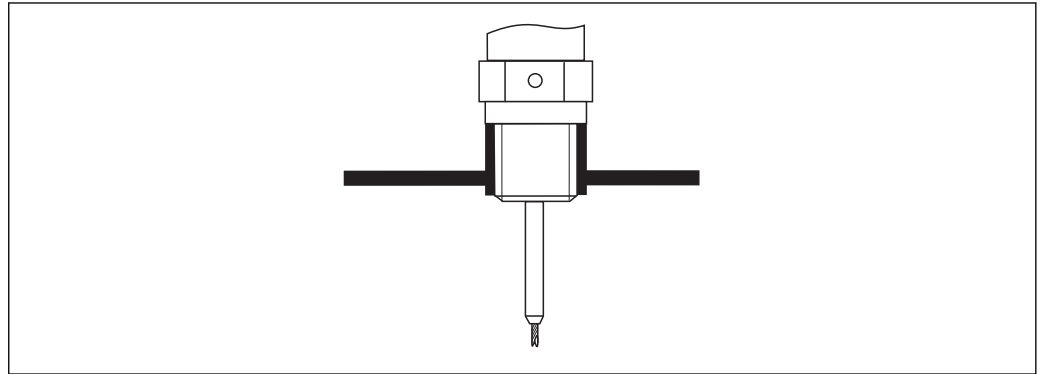

 5 Mounting with threaded connection; flush with the container ceiling

A0015121

Seal

The thread as well as the type of seal comply to DIN 3852 Part 1, screwed plug form A.

They can be sealed with the following types of sealing rings:

- Thread G3/4": According to DIN 7603 with the dimensions 27 x 32 mm
- Thread G1-1/2": According to DIN 7603 with the dimensions 48 x 55 mm

Please use a sealing ring according to this standard in the form A, C or D and of a material that is resistant to the application.

Nozzle mounting

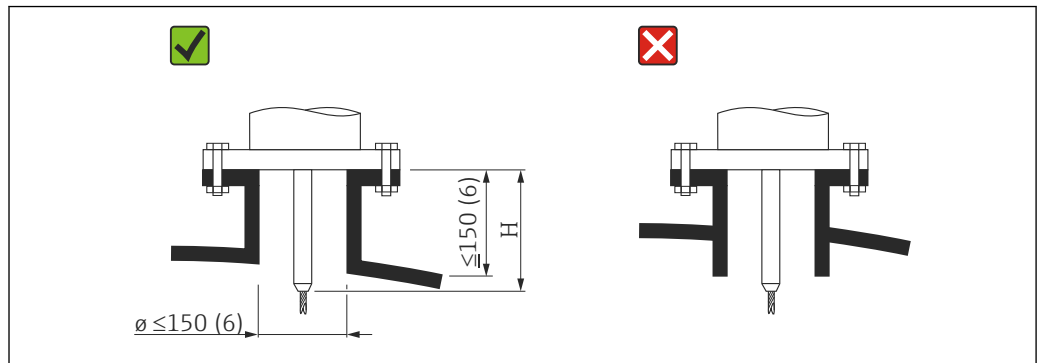

A0015122

- Permissible nozzle diameter: ≤ 150 mm (6 in).
For larger diameters the near range measuring capability may be reduced.
For nozzles $\geq \text{DN}300$: → 31.
 - Permissible nozzle height²⁾: ≤ 150 mm (6 in).
For a larger height the near range measuring capability may be reduced.
Larger nozzle heights may be possible in special cases (see sections "Center rod for FMP51 and FMP52" and "Rod extension/centering HMP40 for FMP54").
 - The end of the nozzle should be flush with the tank ceiling in order to avoid ringing effects.
- With thermally insulated vessels the nozzle should also be insulated in order to prevent condensate formation.

2) Larger nozzle heights on request

Center rod for FMP51 and FMP52

For rope probes it may be necessary to use a version with center rod in order to prevent the probe rod from coming into contact with the nozzle wall. Probes with center rod are available for FMP51 and FMP52.

Probe	Max. nozzle height (= length of the center rod)	Option to be selected in feature 060 ("Probe")
FMP51	150 mm	LA
	6 inch	LB
	300 mm	MB
	12 inch	MD
FMP52	150 mm	OA
	6 inch	OC
	300 mm	OB
	12 inch	OD

Rod extension/centering HMP40 for FMP54

For FMP54 with rope probes the rod extension/centering HMP 40 is available as an accessory →  115. It has to be used if otherwise the probe rope comes into contact with the lower edge of the nozzle.

For FMP54 with rope probes the rod extension/centering HMP 40 is available as an accessory. It has to be used if otherwise the probe rope comes into contact with the lower edge of the nozzle.

 This accessory consists of the extension rod corresponding to the nozzle height, on which a centering disk is also mounted if the nozzles are narrow or when working in bulk solids. This component is delivered separately from the device. Please order the probe length correspondingly shorter.

Centering disks with small diameters (DN40 and DN50) may only be used if there is no significant build-up in the nozzle above the disk. The nozzle must not become clogged by the product.

Installation in nozzles \geq DN300

If installation in \geq 300mm/12" nozzles is unavoidable, installation must be carried out in accordance with the following sketch.

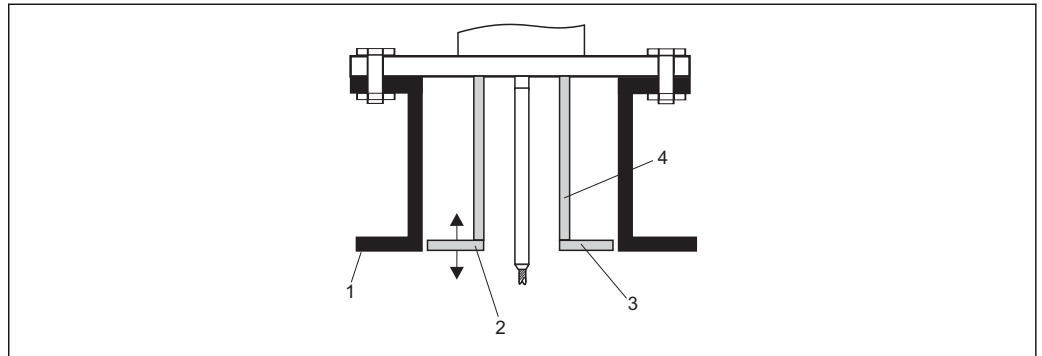

- 1 Lower edge of the nozzle
- 2 Approx. flush with the lower edge of the nozzle (\pm 50 mm/2")
- 3 Plate
- 4 Pipe ϕ 150 to 180 mm (6 to 7 inch)

Nozzle diameter	Plate diameter
300 mm (12")	280 mm (11")
\geq 400 mm (16")	\geq 350 mm (14")

6.1.5 Mounting cladded flanges

- i** For cladded flanges of FMP52, observe the following:
- Use flange screws according to the number of flange holes.
 - Tighten the screws with the required torque (see table).
 - Retighten the screws after 24 hours or after the first temperature cycle.
 - Depending on process pressure and process temperature check and retighten the screws at regular intervals.
- i** Usually, the PTFE flange cladding also serves as a seal between the nozzle and the device flange.

Flange size	Number of screws	Recommended torque [Nm]	
		minimum	maximum
EN			
DN40/PN40	4	35	55
DN50/PN16	4	45	65
DN50/PN40	4	45	65
DN80/PN16	8	40	55
DN80/PN40	8	40	55
DN100/PN16	8	40	60
DN100/PN40	8	55	80
DN150/PN16	8	75	115
DN150/PN40	8	95	145
ASME			
1½"/150lbs	4	20	30
1½"/300lbs	4	30	40
2"/150lbs	4	40	55
2"/300lbs	8	20	30
3"/150lbs	4	65	95
3"/300lbs	8	40	55
4"/150lbs	8	45	70
4"/300lbs	8	55	80
6"/150lbs	8	85	125
6"/300lbs	12	60	90
JIS			
10K 40A	4	30	45
10K 50A	4	40	60
10K 80A	8	25	35
10K 100A	8	35	55
10K 100A	8	75	115

6.1.6 Securing the probe

Securing rope probes

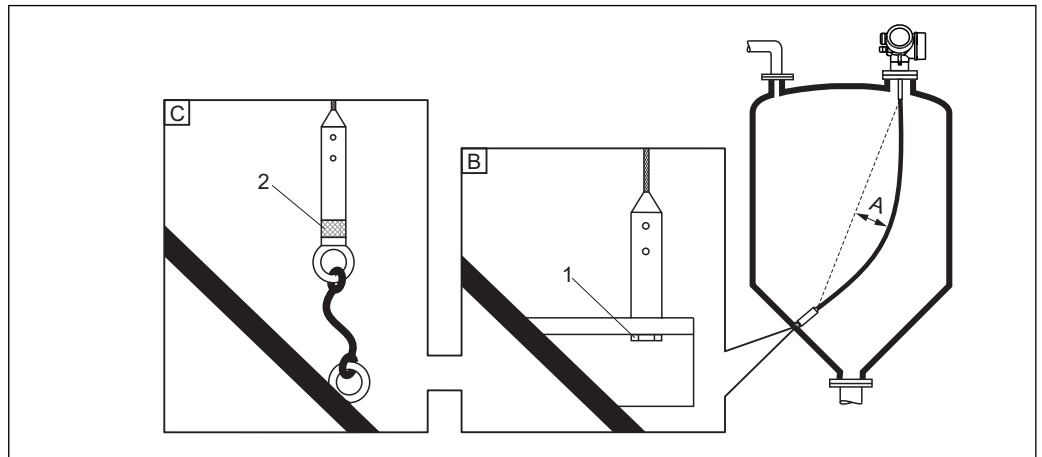

- A Sag of the rope: $\geq 1 \text{ cm per } 1 \text{ m of the probe length (0.12 inch per } 1 \text{ ft of the probe length)}$
- B Reliably grounded end of probe
- C Reliably isolated end of probe
- 1: Mounting and contact with a bolt
- 2 Mounting kit isolated

- The end of the probe needs to be secured under the following conditions: if otherwise the probe sporadically comes into contact with the wall of the vessel, the outlet cone, internal fittings or other parts of the installation.
- The end of probe can be secured at its internal thread
rope 4 mm (1/6"), 316: M 14
- The fixing must be either reliably grounded or reliably insulated. If it is not possible to mount the probe weight with a reliably insulated connection, it can be secured using an isolated eyelet, which is available as an accessory.
- In the case of a grounded fixing the search for a positive end-of-probe signal must be activated. Otherwise an automatic probe length correction is impossible.
Navigation: Expert → Sensor → EOP evaluation → EOP search mode
Setting: **Positive EOP** option
- In order to prevent an extremely high tensile load (e.g. due to thermal expansion) and the risk of rope crack, the rope has to be slack. Make the rope longer than the required measuring range such that there is a sag in the middle of the rope that is $\geq 1 \text{ cm}/(1 \text{ m rope length)}$ [0.12 inch/(1 ft rope length)].
Tensile load limit of rope probes: → 📄 25

Securing rod probes

- For WHG approvals: For probe lengths ≥ 3 m (10 ft) a support is required.
- In general, rod probes must be supported if there is a horizontal flow (e.g. from an agitator) or in the case of strong vibrations.
- Rod probes may only be supported at the end of the probe.

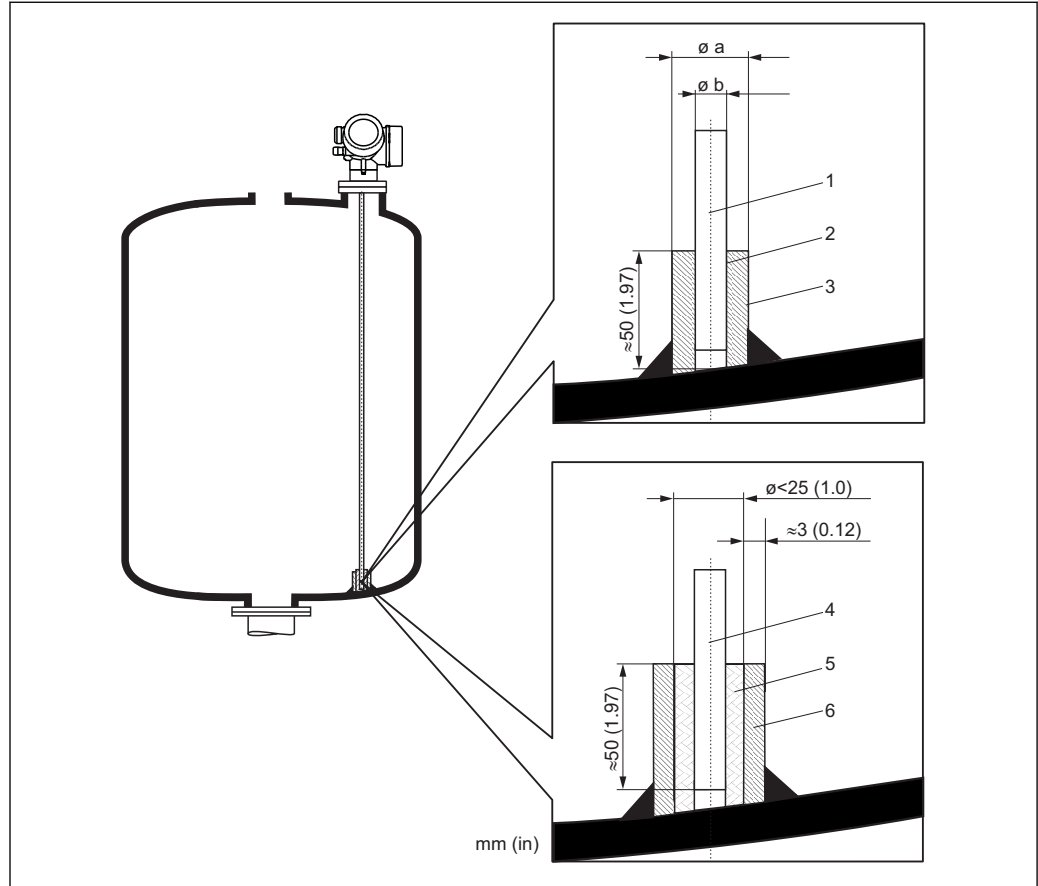

A0012607

- 1 Probe rod, uncoated
- 2 Sleeve bored tight to ensure electrical contact between the rod and sleeve!
- 3 Short metal pipe, e.g. welded in place
- 4 Probe rod, coated
- 5 Plastic sleeve, e.g. PTFE, PEEK or PPS
- 6 Short metal pipe, e.g. welded in place

ϕ probe	ϕ a [mm (inch)]	ϕ b [mm (inch)]
8 mm (1/3")	< 14 (0.55)	8.5 (0.34)
12 mm (1/2")	< 20 (0.78)	12.5 (0.52)
16 mm (0.63in)	< 26 (1.02)	16.5 (0.65)

NOTICE

Poor grounding of the end of probe may cause measuring errors.

- ▶ Apply a narrow sleeve which has good electrical contact to the probe.

NOTICE

Welding may damage the main electronics module.

- ▶ Before welding: Ground the probe and dismount electronics.

Securing coax probes

For WHG approvals: For probe lengths ≥ 3 m (10 ft) a support is required.

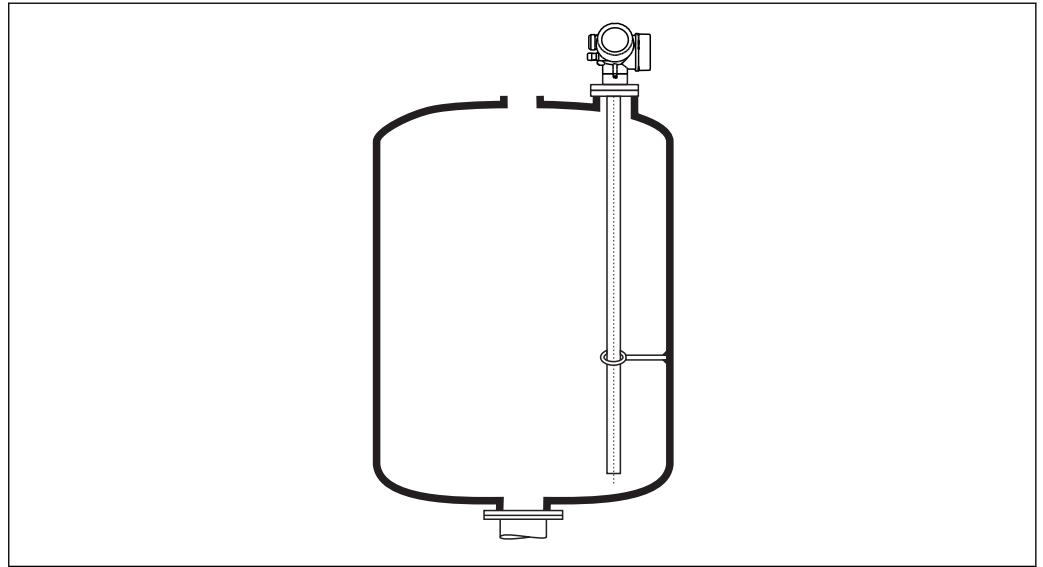

A0012608

Coax probes can be supported at any point of the outer tube.

6.1.7 Special mounting conditions

Bypasses and stilling wells

i In bypass and stilling well applications it is recommended to use a centering disks or stars.

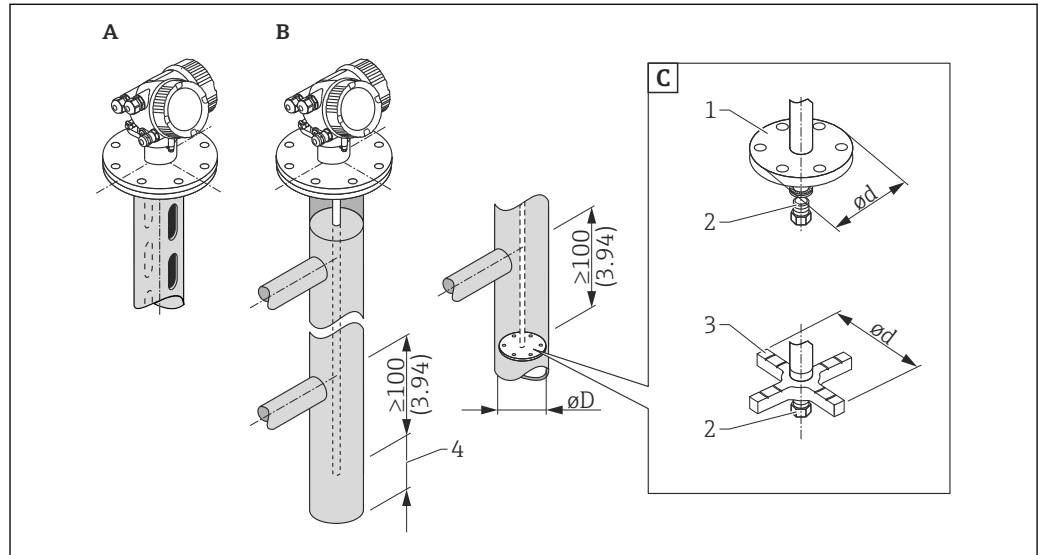

6 Dimensions: mm (in)

- A Mounting in a stilling well
- B Mounting in a bypass
- C Center washer or centering star
- 1 Metallic center washer (316L) for level measurement
- 2 Fixing screw; torque: 25 Nm ± 5 Nm
- 3 Non-metallic centering star (PEEK, PFA) for interface measurement
- 4 Minimum distance between end of probe and lower edge of the bypass; see table below

Allocation of probe type and center washer or centering star to pipe diameter

Feature 610 - Accessory mounted					
Application	Option	Type of probe	Center washer Centering star		Pipe
			ϕd [mm (in)]	Material	ϕD [mm (in)]
Level measurement	OA	Rod probe	75 (2,95)	316L	DN80/3" to DN100/4"
	OB	Rod probe	45 (1,77)	316L	DN50/2" to DN65/2½"
	OC	Rope probe	75 (2,95)	316L	DN80/3" to DN100/4"
Interface measurement	OD	Rod probe	48...95 (1,89...3,74)	PEEK	≥ 50 mm (2")
	OE	Rod probe	37 (1,46)	PFA	≥ 40 mm (1.57")

Minimum distance between end of probe and lower edge of the bypass

Type of probe	Minimum distance
Rope	150 mm (6 in)
Rod	10 mm (0.4 in)
Coax	10 mm (0.4 in)

- Pipe diameter: > 40 mm (1.6") for rod probes
- Rod probe installation can take place up to a diameter size of 150 mm (6 in). In the event of larger diameters, a coax probe is recommended.
- Side disposals, holes or slits and welded joints that protrude up to approx. 5 mm (0.2") inwards do not influence the measurement.
- The pipe may not exhibit any steps in diameter.
- The probe must be 100 mm longer than the lower disposal.
- Within the measuring range, the probe must not get into contact with the pipe wall. If necessary, secure the probe by retaining or tensioning. All rope probes are prepared for tensioning in containers (tensioning weight with anchor hole).
- If a metallic center washer is mounted at the end of the probe, it enables a reliable recognition of the end-of-probe signal (see feature 610 of the product structure).
Note: For interface measurements only use the nonmetallic centering star made of PEEK or PFA (feature 610, options OD or OE).
The center washer or spacer is also available as an accessory: →  113.
- Coax probes can always be applied if there is enough mounting space.

 For bypasses with condensate formation (water) and a medium with low dielectric constant (e.g. hydrocarbons):

In the course of time the bypass is filled with condensate up to the lower disposal and for low levels the the level echo is superimposed by the condensate echo. Thus in this range the condensate level is measured instead of the correct level. Only higher levels are measured correctly. To prevent this, position the lower disposal 100 mm (4 in) below the lowest level to be measured and apply a metallic centering disk at the height of the lower edge of the lower disposal.

 With heat insulated tanks the bypass should also be insulated in order to prevent condensate formation.

 For information on bypass solutions from Endress+Hauser please contact your Endress+Hauser sales representative.

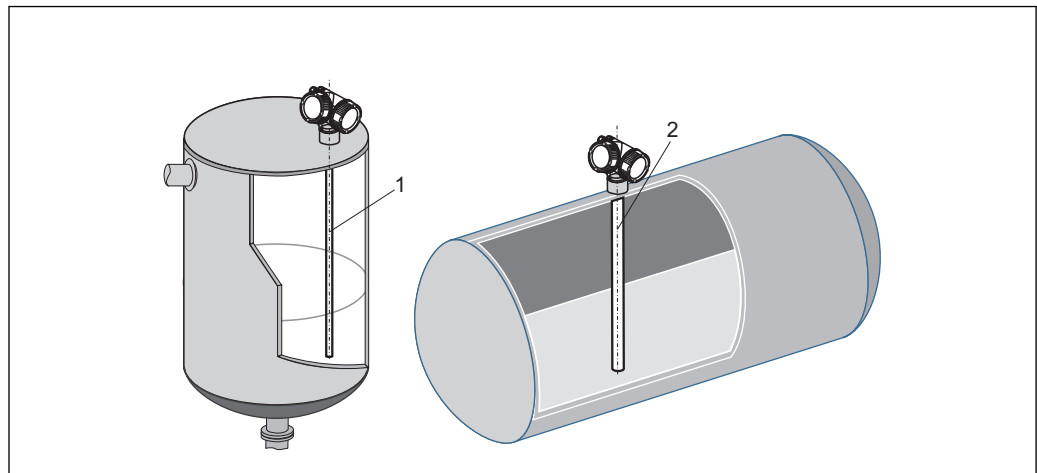
Installation in horizontal and upright cylindrical tanks

A0014141

- Any distance from wall, as long as occasional contact is prevented.
- When installing in tanks with a lot of internals or internals situated close to the probe: use a coax probe.

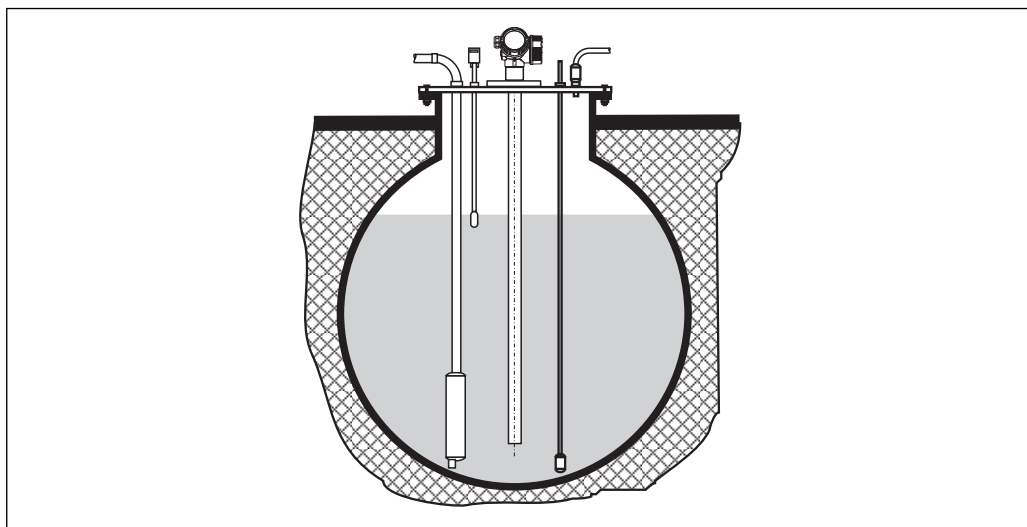
Underground tanks

A0014142

Use a coax probe for nozzles with large diameters in order to avoid reflections at the nozzle wall.

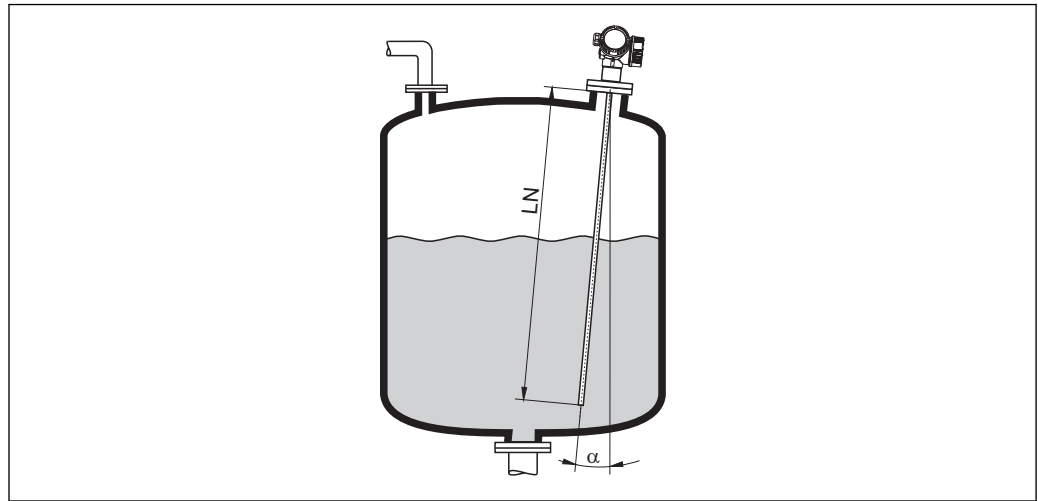
Installation at an angle

A0014145

- For mechanical reasons, the probe should be installed as vertically as possible.
- With inclined installations the probe length has to be adjusted in dependence to the installation angle.
 - Up to LN = 1 m (3.3 ft): $\alpha = 30^\circ$
 - Up to LN = 2 m (6.6 ft): $\alpha = 10^\circ$
 - Up to LN = 4 m (13.1 ft): $\alpha = 5^\circ$

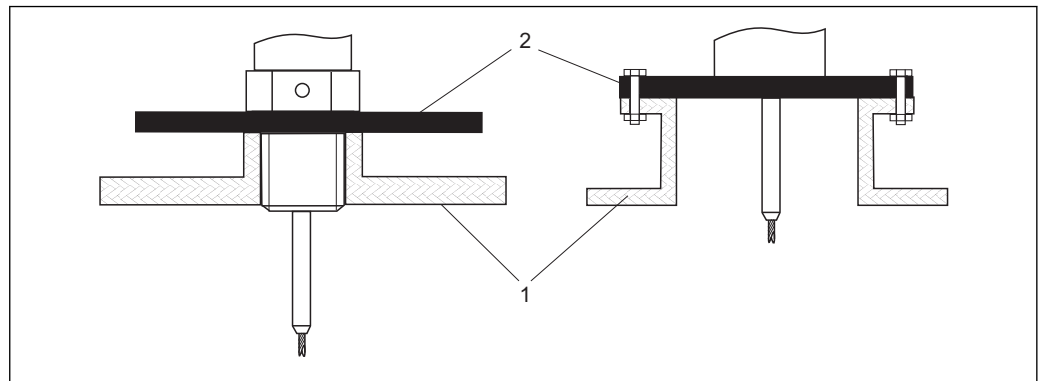
Non-metallic vessels

- 1 Non-metallic vessel
2 Metal sheet or metal flange

To ensure reliable measurements in non-metallic vessels:

- Select an instrument version with metal flange (minimum size DN50/2").
- Or: mount a metal sheet with a diameter of at least 200 mm (8 in) to the probe at the process connection. Its orientation must be perpendicular to the probe.



A metallic surface is not required for coax probes.

Plastic or glass tanks: Mounting the probe externally at the wall

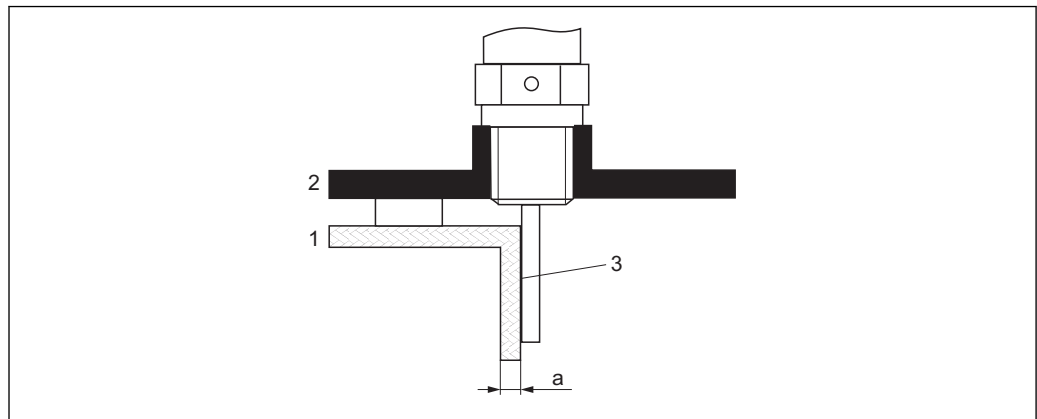

A0014150

- 1 Plastic or glass tank
- 2 Metall sheet with threaded sleeve
- 3 No free space between tank wall and probe!

Requirements

- The dielectric constant of the medium must be at least $DC > 7$.
- The tank wall must be non-conductive.
- Maximum wall thickness (a):
 - Plastic: < 15 mm (0.6")
 - Glass: < 10 mm (0.4")
- There may be no metallic reinforcements fixed to the tank.

Mounting conditions:

- The probe must be mounted directly to the tank wall (no open space)
- A plastic half pipe with a diameter of approx. 200 mm (8"), or some other protective unit, must be affixed externally to the probe to prevent any influences on the measurement.
- If the tank diameter is less than 300 mm (12"):
 - A metallic grounding sheet must be installed at the opposite side of the tank. The sheet must be conductively connected to the process connection and cover about the half of the vessel's circumference.
- If the tank diameter exceeds 300 mm (12"):
 - A metal sheet with a diameter of at least 200 mm (8") must be mounted to the probe at the process connection. Its orientation must be perpendicular to the probe (see above).

Calibration for external probe mounting

If the probe is mounted externally at the wall of the tank, the speed of signal propagation will be reduced. There are two possibilities to compensate for this effect.

Compensation with the gas phase compensation factor

The effect of the dielectric wall can be compared to the effect of a dielectric gas phase. Thus it can be compensated for in the same manner. The compensation factor is given by the quotient of the actual probe length L_N and the probe length measured when the tank is empty.

- i** The device looks for the end of probe signal in the subtracted curve. Thus, the value of the measured probe length depends on the mapping. In order to obtain an exact value, it is advisable to determine the probe length manually using the envelope curve display in FieldCare.

Step	Parameter	Action
1	Expert → Sensor → Gas phase compensation → GPC mode	Select the Const. GPC factor option.
2	Expert → Sensor → Gas phase compensation → Const. GPC factor	Enter quotient: "(Actual probe length)/(Measured probe length)".

Compensation via the calibration parameters

If an actual gas phase has to be compensated for, the gas phase compensation functionality is no longer available for a correction of the external mounting. In this case the calibration parameters (**Empty calibration** and **Full calibration**) must be adjusted and a value longer than the actual probe length has to be entered into the **Present probe length** parameter. The correction factor for these three parameters is given by the quotient of the probe length measured when the tank is empty and the actual probe length LN.

 The device looks for the end of probe signal in the subtracted curve. Thus, the value of the measured probe length depends on the mapping. In order to obtain an exact value, it is advisable to determine the probe length manually using the envelope curve display in FieldCare.

Step	Parameter	Action
1	Setup → Empty calibration	Increase parameter value by "(Measured probe length)/(Actual probe length)".
2	Setup → Full calibration	Increase parameter value by "(Measured probe length)/(Actual probe length)".
3	Setup → Advanced setup → Probe settings → Probe length correction → Confirm probe length	Select the Manual input option.
4	Setup → Advanced setup → Probe settings → Probe length correction → Present probe length	Enter measured probe length.

Vessels with heat insulation

i If process temperatures are high, the device must be included in normal tank insulation to prevent the electronics heating up as a result of heat radiation or convection. The insulation may not exceed beyond the points labeled "MAX" in the drawings.

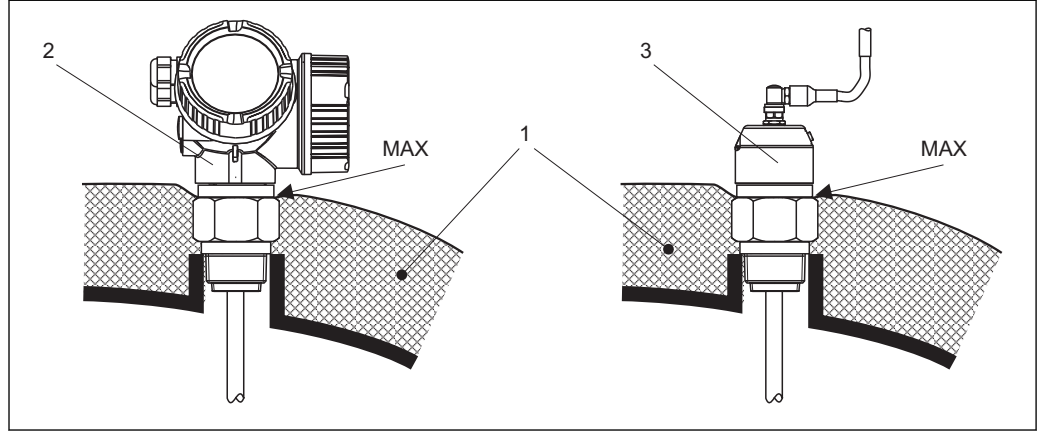

7 Process connection with thread - FMP51

- 1 Tank insulation
- 2 Compact device
- 3 Sensor remote (feature 600)

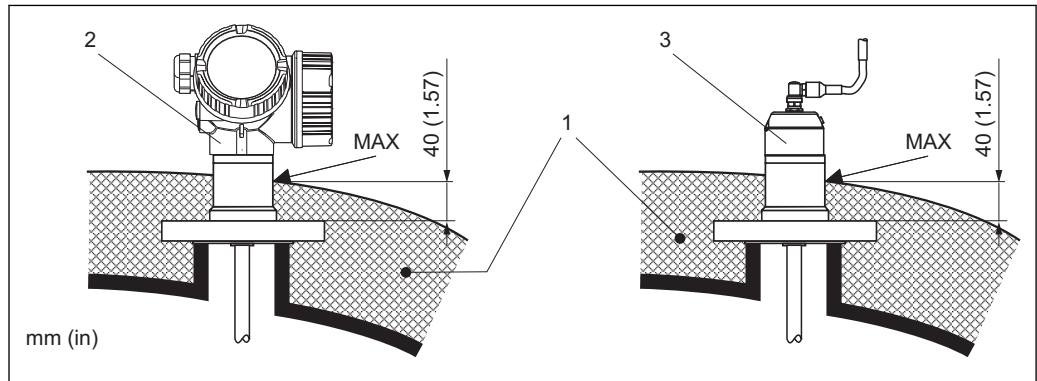

8 Process connection with flange - FMP51, FMP52

- 1 Tank insulation
- 2 Compact device
- 3 Sensor remote (feature 600)

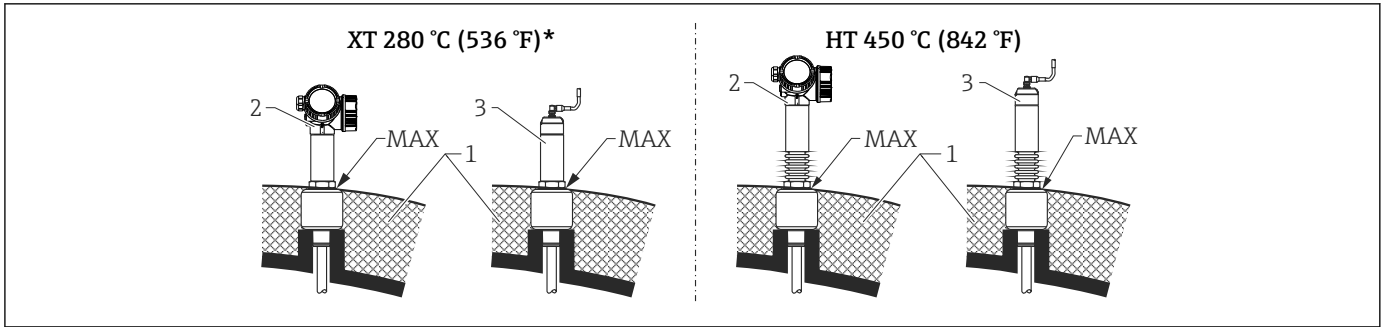

A0014657

9 Process connection with thread - FMP54, sensor version XT and HT

- 1 Tank insulation
- 2 Compact device
- 3 Sensor remote (feature 600)

* The XT version is not recommended for saturated steam above 200 °C (392 °F). Use the HT version instead.

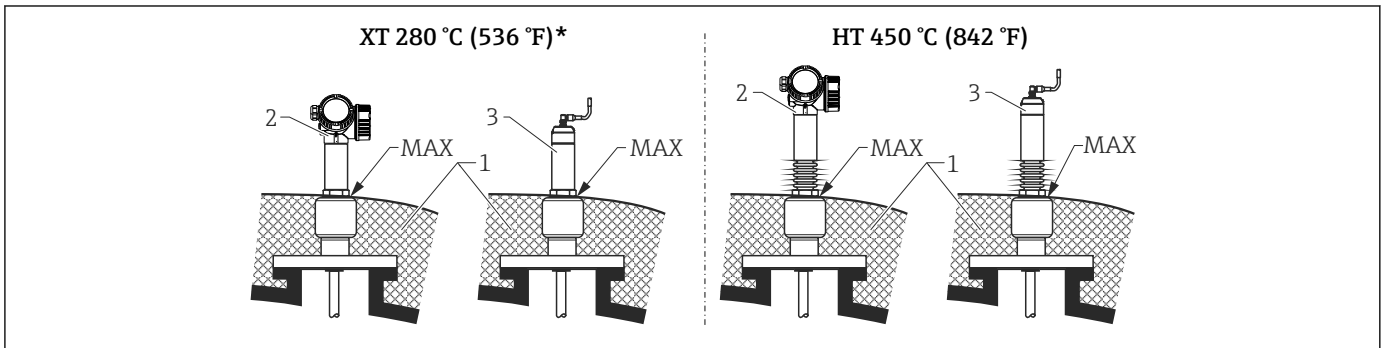

A0014658

10 Process connection with flange - FMP54, sensor version XT and HT

- 1 Tank insulation
- 2 Compact device
- 3 Sensor remote (feature 600)

* The XT version is not recommended for saturated steam above 200 °C (392 °F). Use the HT version instead.

Replacing a displacer system in an existing displacer chamber

FMP51 and FMP54 are a perfect replacement for a conventional displacer system in an existing displacer chamber. Endress+Hauser offers flanges that suit Fischer and Masoneilan displacer chamber for this purpose (special product for FMP51; feature 100, options LNJ, LPJ, LQJ for FMP54). Thanks to menu-guided local operation, commissioning the Levelflex only takes a few minutes. Replacement is also possible when partially filled, and wet calibration is not required.

Your benefits:

- No moving parts, thus zero-maintenance operation.
- Not sensitive to process influences such as temperature, density, turbulence and vibrations.
- The rod probes can be shortened or replaced easily. In this way, the probe can be easily adjusted on site.

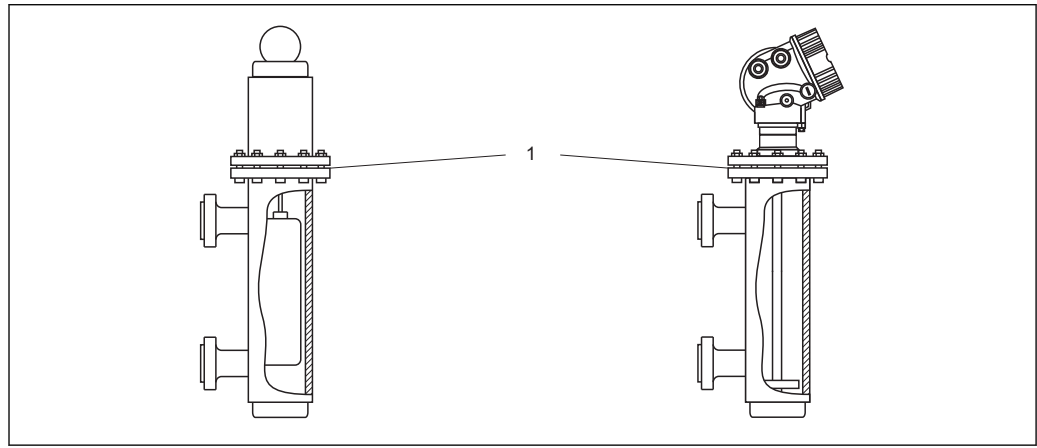

A0014153

1 Flange of the displacer chamber

Planning instructions:

- In normal cases, use a rod probe. When installing into a metallic displacer chamber up to 150 mm, you have all the advantages of a coax probe.
- It must be ensured that the probe does not come into contact with the side wall. Where necessary, use a center washer or centering star at the lower end of the probe (feature 610 of the product structure).
- The center washer or centering star must be adapted as accurately as possible to the internal diameter of the displacer chamber to also ensure perfect operation in the area of the probe end.

Additional information on interface measurement

- In the case of oil and water the centering disk or centering star should be positioned at the lower edge of the lower disposal (water level).
- The pipe may not exhibit any steps in diameter. Use the coax probe where necessary.
- In the case of rod probes, it must be ensured that the probe does not come into contact with the wall. If necessary, use a center washer or centering star at the end of the probe.
- A plastic centering star has to be used for interface measurement (feature 610, options OD and OE).

6.2 Mounting the device

6.2.1 Required mounting tools

- For mounting thread 3/4": Hexagonal wrench 36 mm
- For mounting thread 1-1/2": Hexagonal wrench 55 mm
- To shorten rod or coax probes: Saw
- To shorten rope probes:
 - Allen key AF 3 mm (for 4mm ropes) or AF 4 mm (for 6 mm ropes)
 - Saw or bolt cutter
- For flanges and other process connections: appropriate mounting tools
- To turn the housing: Hexagonal wrench 8 mm

6.2.2 Shortening the probe

- i** When shortening the probe: Enter the new length of probe into the Quick Setup which can be found in the electronics housing behind the display module.

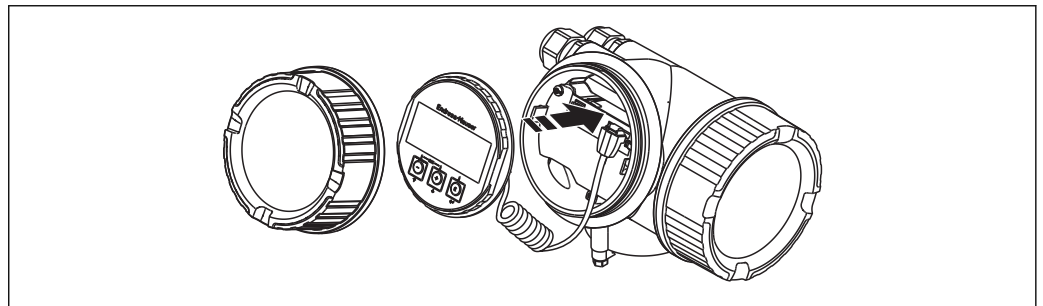

A0014241

Shortening rod probes

Rod probes must be shortened if the distance to the container floor or outlet cone is less than 10 mm (0.4 in). The rods of a rod probe are shortened by sawing at the bottom end.

- i** Rod probes of FMP52 can **not** be shortened as they are coated.

Shortening rope probes

Rope probes must be shortened if the distance to the container floor or outlet cone is less than 150 mm (6 in).

- i** Rope probes of FMP52 can **not** be shortened as they are coated.

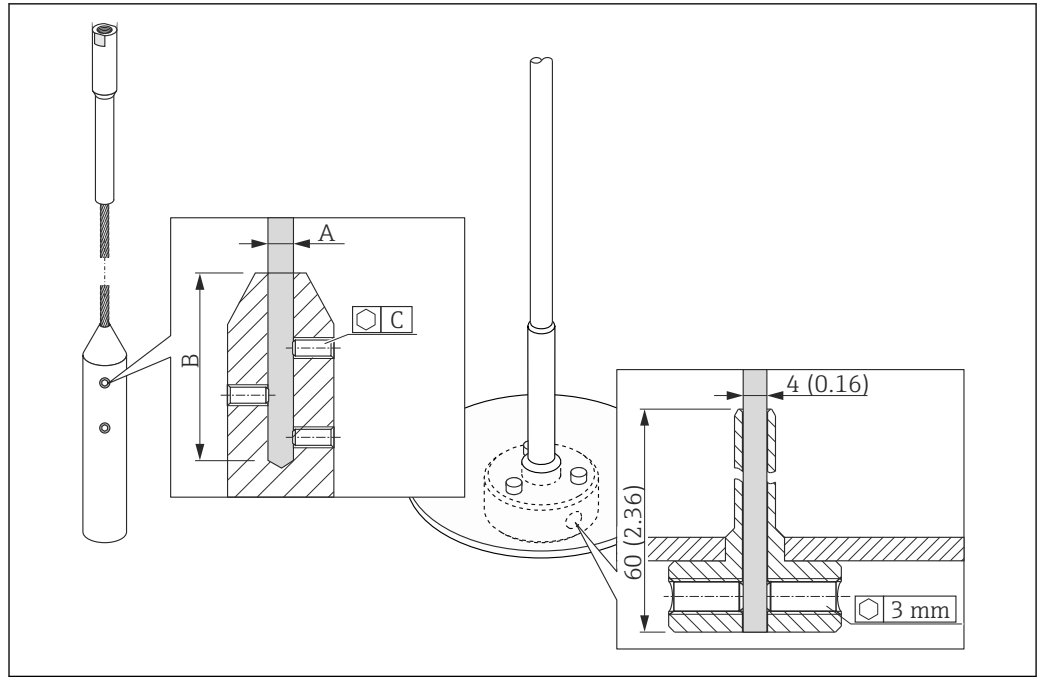

Rope material	A	B	C	Torque for set screws
316	4 mm (0.16 in)	40 mm (1.6 in)	3 mm	5 Nm (3.69 lbf ft)

1. Using an Allen key, loosen the set screws at the end-of-probe weight or the clamping sleeve of the centering disk. Note: The set screws have got a clamping coating in order to prevent accidental loosening. Thus an increased torque might be necessary to loosen them.
2. Remove released rope from the weight or sleeve.
3. Measure off new rope length.
4. Wrap adhesive tape around the rope at the point to be shortened to prevent it from fanning out.
5. Saw off the rope at a right angle or cut it off with a bolt cutter.
6. Insert the rope completely into the weight or sleeve.
7. Screw the set screws into place. Due to the clamping coating of the setscrews application of a screw locking fluid is not necessary.

Shortening coax probes

Coax probes must be shortened if the distance to the container floor or outlet cone is less than 10 mm (0.4 in).

i Coax probes can be shortened max. 80 mm (3.2 in) from the end. They have centering units inside, which fix the rod centrally in the pipe. The centerings are held with borders on the rod. Shortening is possible up to approx. 10 mm (0.4 in) below the centering unit.

The coax probe is shortened by sawing the pipe at the bottom end.

6.2.3 FMP54 with gas phase compensation: Mounting the probe rod

i This section is only valid for FMP54 with gas phase compensation (product structure: feature 540 "Application Package", option EF or EG).

Coax probes

Coax probes with reference reflection are completely mounted and adjusted on delivery. After mounting they are ready for use. Additional settings are not necessary.

Rod probes

For rod probes with reference reflection the probe rod is delivered separately and has to be mounted as follows:

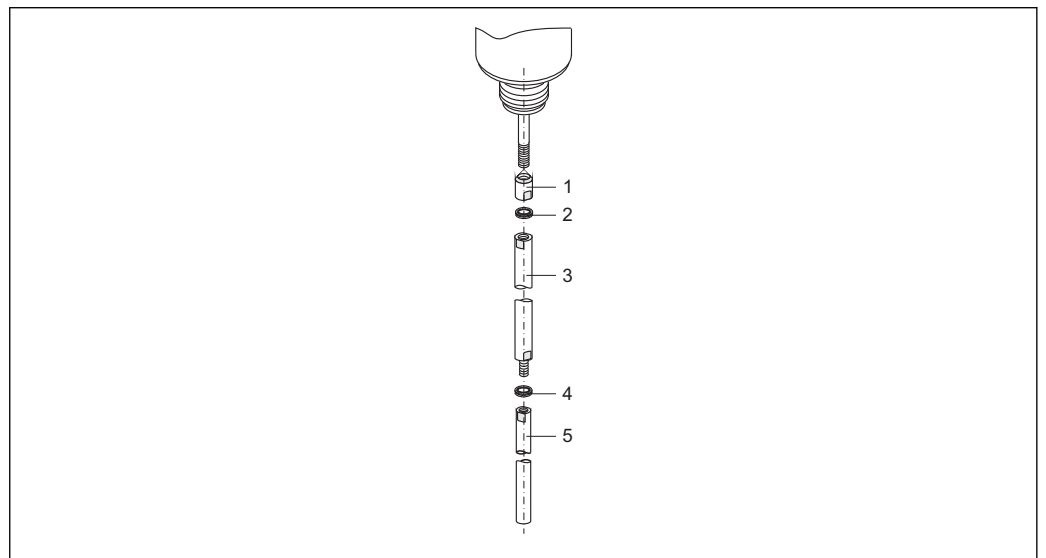

A0014565

1. Screw the counter nut onto the connection thread (M10x1) of the gland. Take care that the chamfer is oriented to the gland.
2. Place a pair of Nord-Lock washers on the thread.
3. Screw the probe rod with the larger diameter onto the thread and fasten it hand-tight.
4. Place the second pair of Nord-Lock washers on the threaded bolt.
5. Screw the probe rod with the smaller diameter onto the threaded bolt and tighten it with 15 Nm (torque wrench/spanner AF14).

i After mounting the probe rod in the stilling well or bypass, check and - if necessary - correct the settings in the unpressurized state → 87.

6.2.4 Mounting the device

Mounting devices with thread

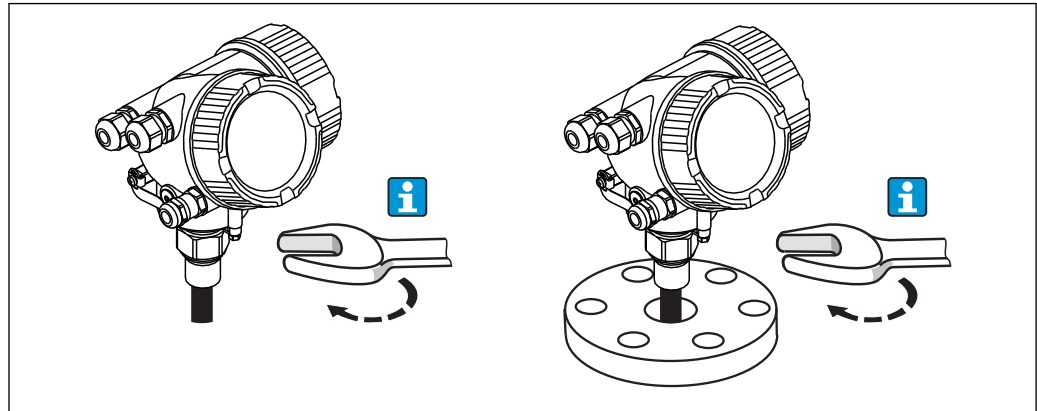

A0012528

Devices with mounting thread are screwed into a welding boss or a flange and are usually also secured with these.

- i** ▪ Tighten with the hexagonal nut only:
 - Thread 3/4": Hexagonal wrench 36 mm
 - Thread 1-1/2": Hexagonal wrench 55 mm
- Maximum permissible torque:
 - Thread 3/4": 45 Nm
 - Thread 1-1/2": 450 Nm
- Recommended torque when using the supplied aramid fibre seal and a process pressure of 40 bar (580 psi):
 - Thread 3/4": 25 Nm
 - Thread 1-1/2": 140 Nm
- When installing in metal containers, take care to ensure good metallic contact between the process connection and container.

Flange mounting

If a seal is used, be sure to use unpainted metal bolts to ensure good electrical contact between probe flange and process flange.

Mounting rope probes

NOTICE

Electrostatic discharges may damage the electronics.

- ▶ Earth the housing before lowering the rope into the vessel.

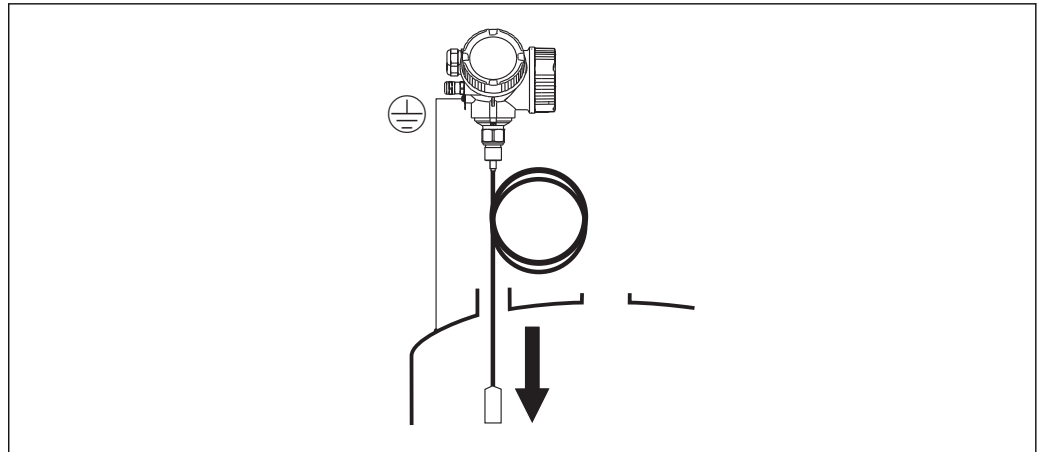

A0012852

When lowering the rope probe into the vessel, observe the following:

- Uncoil rope and lower it slowly and carefully into the vessel.
- Do not kink the rope.
- Avoid any backlash, since this might damage the probe or the vessel fittings.

6.2.5 Mounting the "Sensor remote" version

i This section is only valid for devices of the version "Probe Design" = "Sensor remote" (feature 600, option MB/MC/MD).

For the version "Probe design" = "Sensor remote" the following is supplied:

- The probe with the process connection
- The electronics housing
- The mounting bracket for wall or pipe mounting of the electronics housing
- The connection cable (length as ordered). The cable has got one straight and one angled plug (90°). Depending on the local conditions the angled plug can be connected at the probe or at the electronics housing.

CAUTION

The plugs of the connection cable may be damaged by mechanical stress.

- ▶ Mount the probe and the electronics housing tightly before connecting the cable.
- ▶ Lay the cable such that it is not exposed to mechanical stress. Minimum bending radius: 100 mm (4").
- ▶ When connecting the cable: Connect the straight plug before the angled one. Torque for both coupling nuts: 6 Nm.

i Probe, electronics and connection cable are adjusted to match each other. They are marked by a common serial number. Only components with the same serial number shall be connected to each other.

i If the measuring point is exposed to strong vibrations, an additional locking compound (e.g. Loctite 243) can be applied at the plug connectors.

Mounting the electronics housing

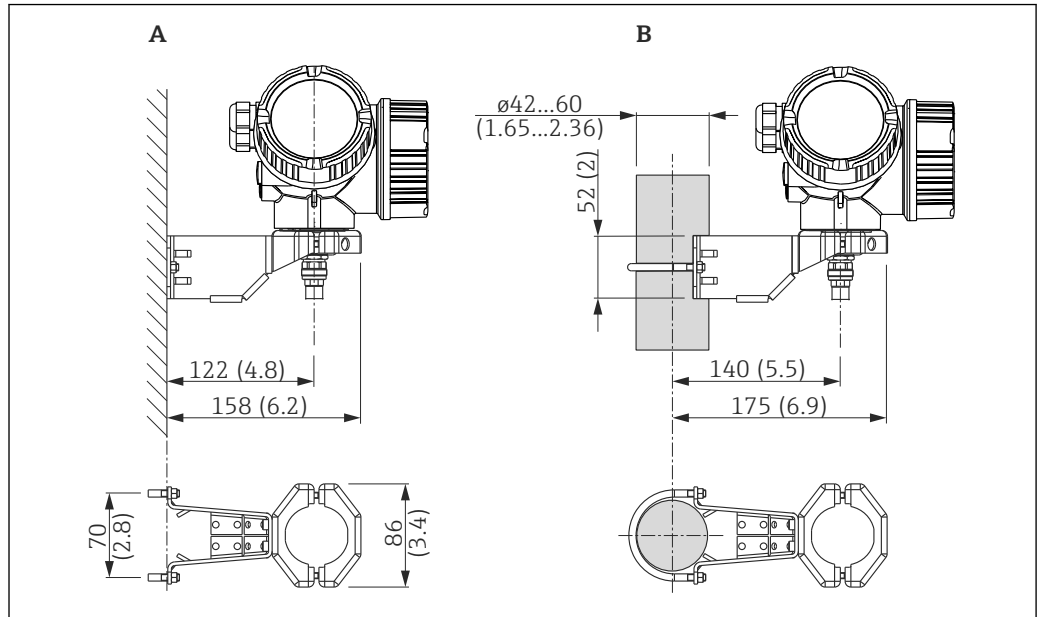

A0014793

11 Mounting the electronics housing using the mounting bracket; dimensions: mm (in)

- A Wall mounting
- B Pipe mounting

Connecting the cable

Required tools:

Open-end wrench 18AF

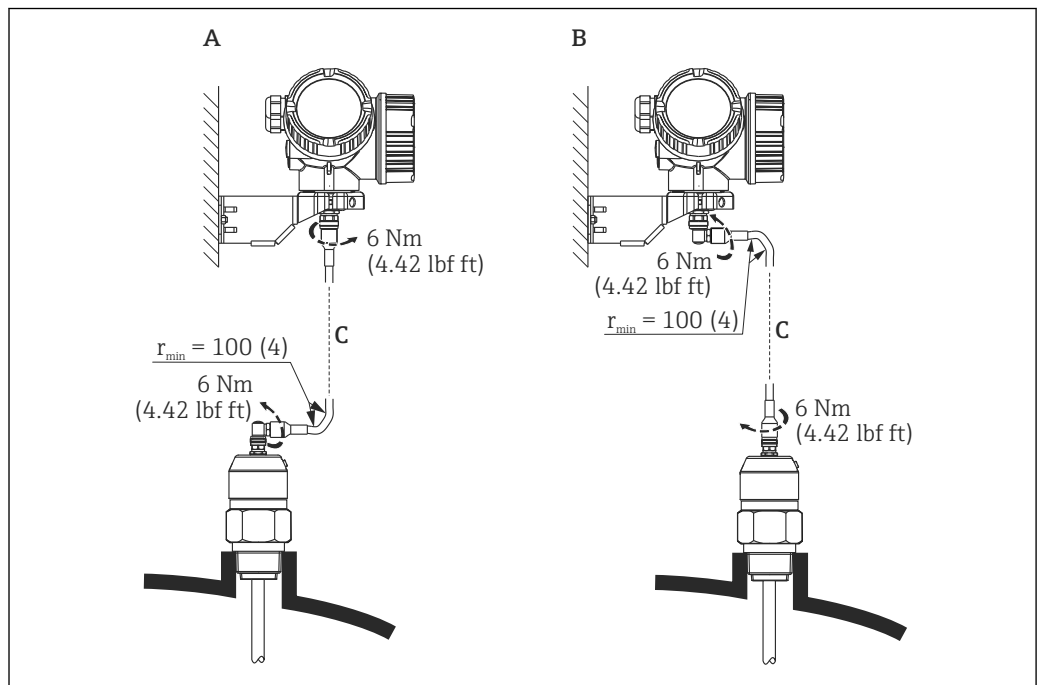

A0014794

12 Connecting the cable. There are the following possibilities:

- A Angled plug at the probe
- B Angled plug at the electronics housing
- C Length of the remote cable as ordered

6.2.6 Turning the transmitter housing

To provide easier access to the connection compartment or display module, the transmitter housing can be turned:

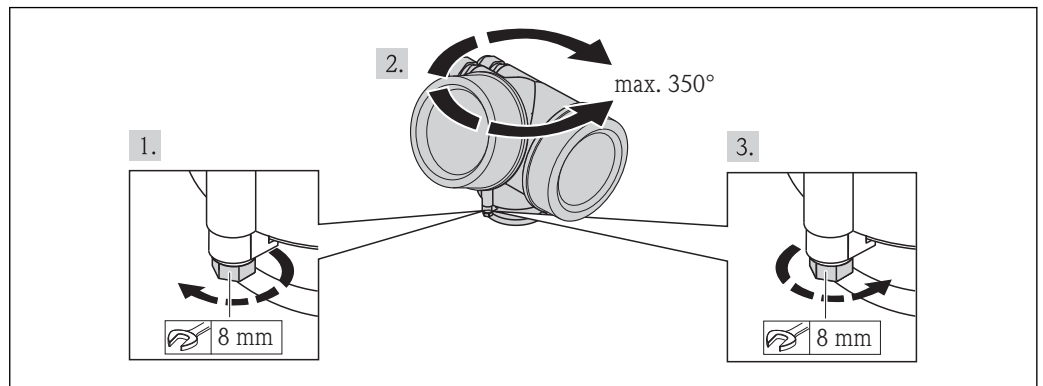

A0013713

1. Unscrew the securing screw using an open-ended wrench.
2. Rotate the housing in the desired direction.
3. Tighten the securing screw (1,5 Nm for plastics housing; 2,5 Nm for aluminium or stainless steel housing).

6.2.7 Turning the display module

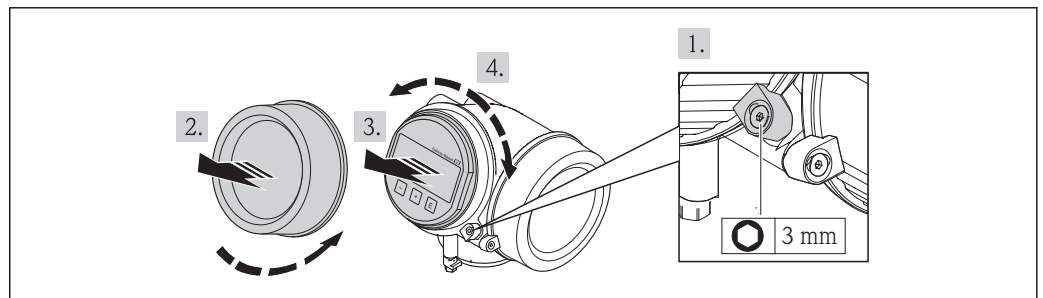

A0013905

1. If present: Loosen the screw of the securing clamp of the electronics compartment cover using an Allen key and turn the clamp 90° counterclockwise.
2. Unscrew cover of the electronics compartment from the transmitter housing.
3. Pull out the display module with a gentle rotation movement.
4. Rotate the display module into the desired position: Max. $8 \times 45^\circ$ in each direction.
5. Feed the spiral cable into the gap between the housing and main electronics module and plug the display module into the electronics compartment until it engages.
6. Screw the cover of the electronics compartment firmly back onto the transmitter housing.
7. Tighten the securing clamp again using the Allen key (Torque: 2.5 Nm).

6.3 Post-installation check

<input type="radio"/>	Is the device undamaged (visual inspection)?
<input type="radio"/>	Does the device conform to the measuring point specifications? For example: <ul style="list-style-type: none">▪ Process temperature▪ Process pressure (refer to the chapter on "Material load curves" of the "Technical Information" document)▪ Ambient temperature range▪ Measuring range
<input type="radio"/>	Are the measuring point identification and labeling correct (visual inspection)?
<input type="radio"/>	Is the device adequately protected from precipitation and direct sunlight?
<input type="radio"/>	Are the securing screw and securing clamp tightened securely?

7 Electrical connection

7.1 Connection conditions

7.1.1 Terminal assignment

2-wire: 4-20mA HART

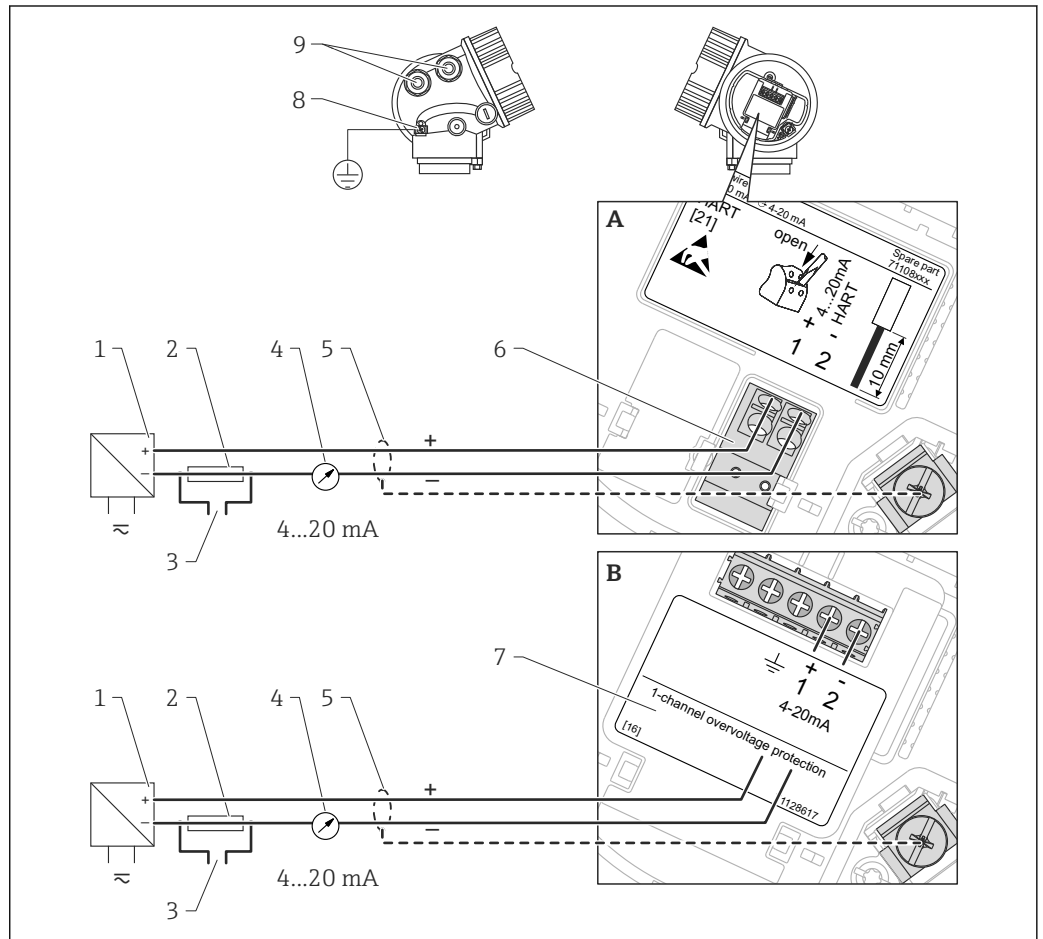

A0011294

13 Terminal assignment 2-wire; 4-20mA HART

A Without integrated overvoltage protection

B With integrated overvoltage protection

1 Active barrier with power supply (e.g. RN221N): Observe terminal voltage

2 HART communication resistor ($\geq 250 \Omega$): Observe maximum load

3 Connection for Commubox FXA195 or FieldXpert SFX350/SFX370 (via VIATOR Bluetooth modem)

4 Analog display device: Observe maximum load

5 Cable screen; observe cable specification

6 4-20mA HART (passive): Terminals 1 and 2

7 Overvoltage protection module

8 Terminal for potential equalization line

9 Cable entry

2-wire: 4-20mA HART, switch output

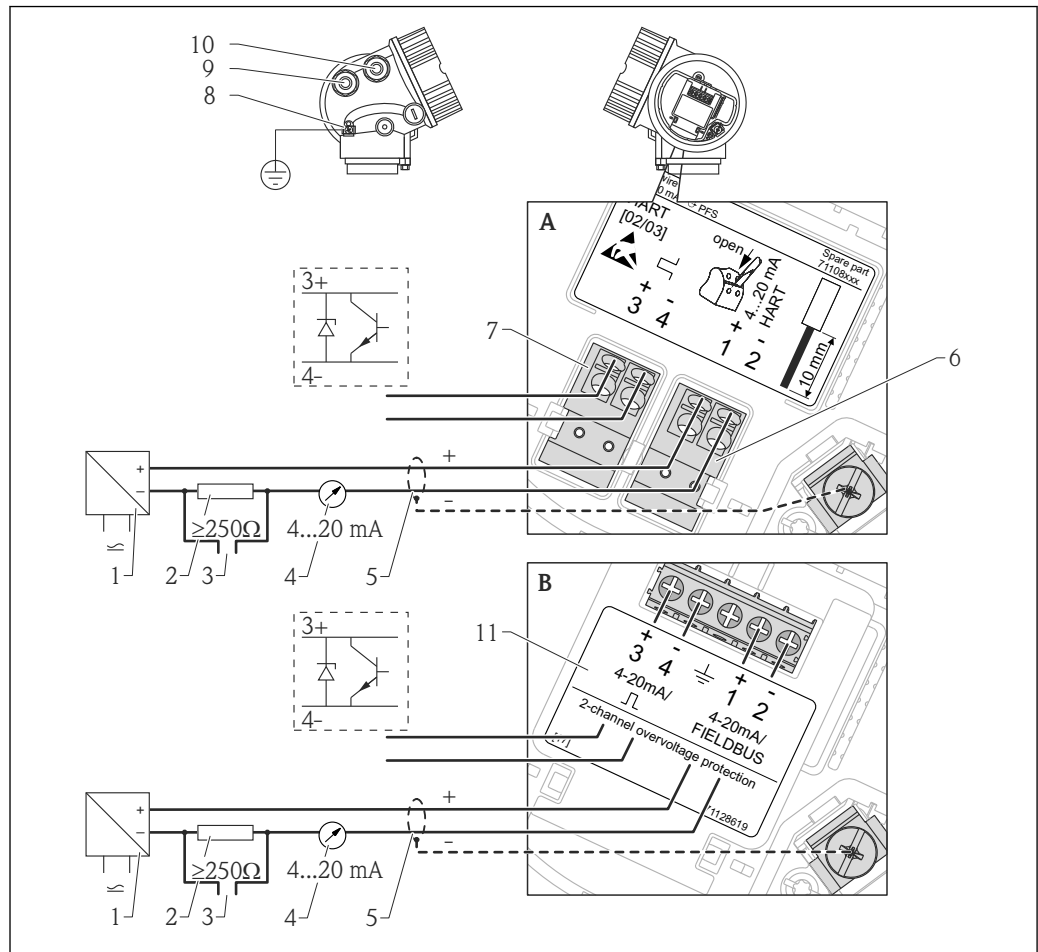

A0013759

14 Terminal assignment 2-wire; 4-20mA HART, switch output

- A Without integrated overvoltage protection
- B With integrated overvoltage protection
- 1 Active barrier with power supply (e.g. RN221N): Observe terminal voltage
- 2 HART communication resistor ($\geq 250\Omega$): Observe maximum load
- 3 Connection for Commubox FXA195 or FieldXpert SFX350/SFX370 (via VIATOR Bluetooth modem)
- 4 Analog display device: Observe maximum load
- 5 Cable screen; observe cable specification
- 6 4-20mA HART (passive): Terminals 1 and 2
- 7 Switch output (open collector): Terminals 3 and 4
- 8 Terminal for potential equalization line
- 9 Cable entry for 4-20mA HART line
- 10 Cable entry for switch output line
- 11 Overvoltage protection module

2-wire: 4-20mA HART, 4-20mA

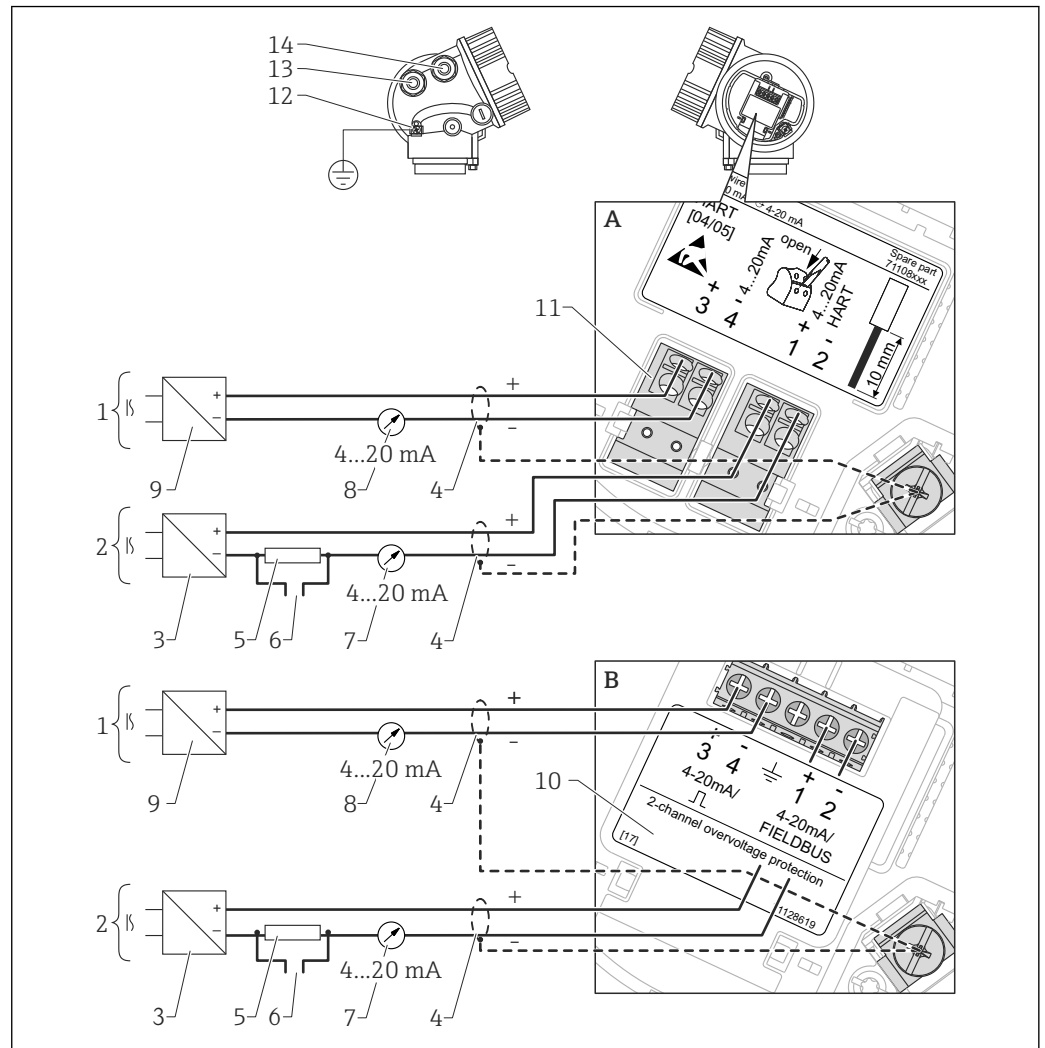

15 Terminal assignment 2-wire, 4-20 mA HART, 4...20mA

- A Without integrated overvoltage protection
- B With integrated overvoltage protection
- 1 Connection current output 2
- 2 Connection current output 1
- 3 Supply voltage for current output 1 (e.g. RN221N); Observe terminal voltage
- 4 Cable screen; observe cable specification
- 5 HART communication resistor ($\geq 250 \Omega$); Observe maximum load
- 6 Connection for Commubox FXA195 or FieldXpert SFX350/SFX370 (via VIATOR Bluetooth modem)
- 7 Analog display device ; observe maximum load
- 8 Analog display device ; observe maximum load
- 9 Supply voltage for current output 2 (e.g. RN221N); Observe terminal voltage
- 10 Overvoltage protection module
- 11 Current output 2: Terminals 3 and 4
- 12 Terminal for the potential equalization line
- 13 Cable entry for current output 1
- 14 Cable entry for current output 2

i This version is also suited for single-channel operation. In this case, current output 1 (terminals 1 and 2) must be used.

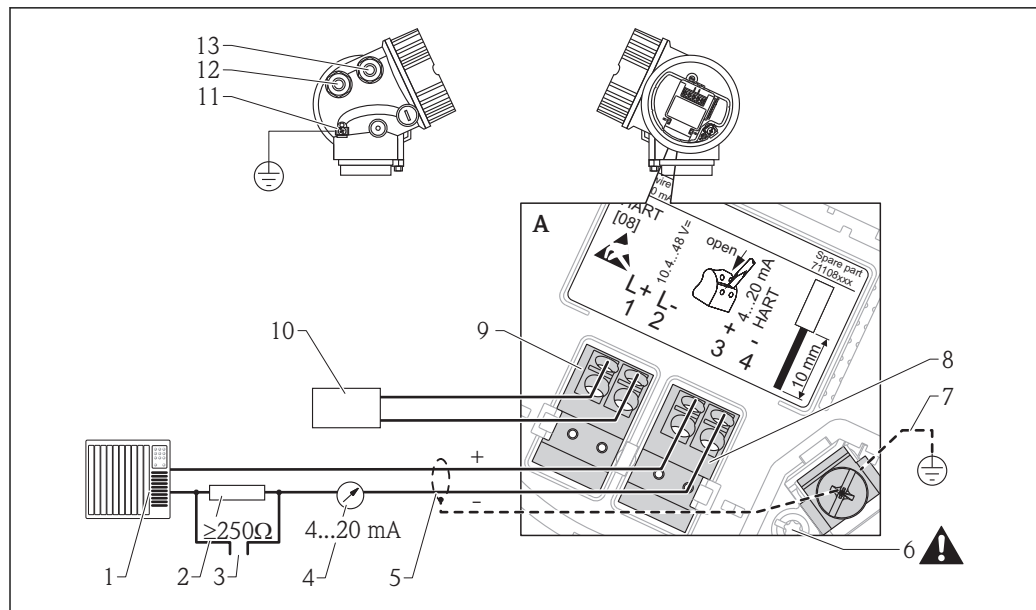
4-wire: 4-20mA HART (10.4 to 48 V_{DC})

A0011340

16 Terminal assignment 4-wire; 4-20mA HART (10.4 to 48 VDC)

- 1 Evaluation unit, e.g. PLC
- 2 HART communication resistor ($\geq 250 \Omega$): Observe maximum load
- 3 Connection for Commubox FXA195 or FieldXpert SFX350/SFX370 (via VIATOR Bluetooth modem)
- 4 Analog display device: Observe maximum load
- 5 Signal cable including screening (if required), observe cable specification
- 6 Protective connection; do not disconnect!
- 7 Protective earth, observe cable specification
- 8 4...20mA HART (active): Terminals 3 and 4
- 9 Supply voltage: Terminals 1 and 2
- 10 Supply voltage: Observe terminal voltage, observe cable specification
- 11 Terminal for potential equalization
- 12 Cable entry for signal line
- 13 Cable entry for power supply

4-wire: 4-20mA HART (90 to 253 V_{AC})

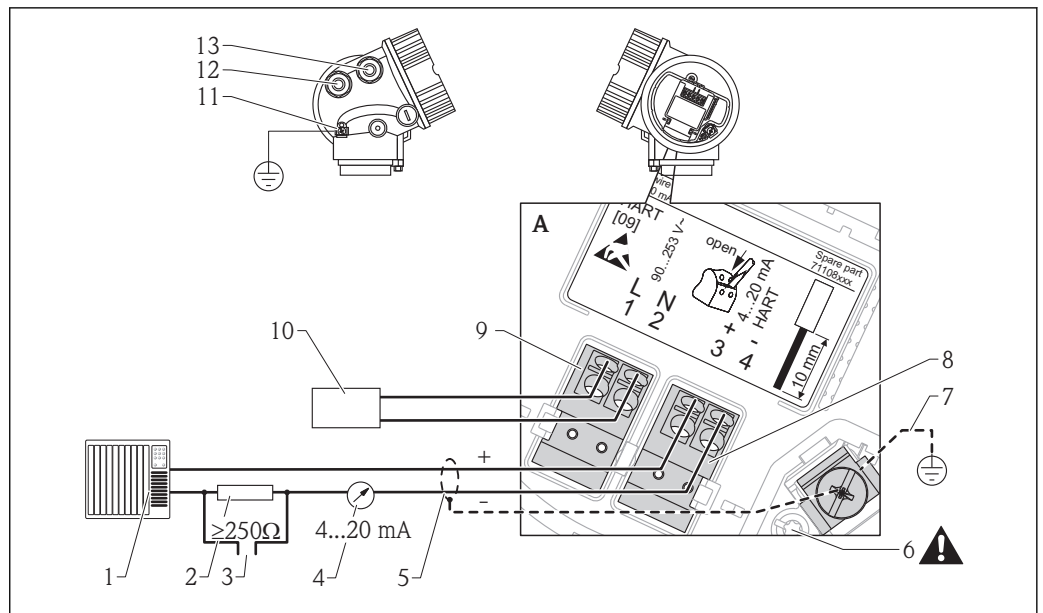

A0018965

17 Terminal assignment 4-wire; 4-20mA HART (90 to 253 V_{AC})

- 1 Evaluation unit, e.g. PLC
- 2 HART communication resistor ($\geq 250 \Omega$): Observe maximum load
- 3 Connection for Commubox FXA195 or FieldXpert SFX350/SFX370 (via VIATOR Bluetooth modem)
- 4 Analog display device: Observe maximum load
- 5 Signal cable including screening (if required), observe cable specification
- 6 Protective connection; do not disconnect!
- 7 Protective earth, observe cable specification
- 8 4...20mA HART (active): Terminals 3 and 4
- 9 Supply voltage: Terminals 1 and 2
- 10 Supply voltage: Observe terminal voltage, observe cable specification
- 11 Terminal for potential equalization
- 12 Cable entry for signal line
- 13 Cable entry for power supply

CAUTION

To ensure electrical safety:

- ▶ Do not disconnect the protective connection (6).
 - ▶ Disconnect the supply voltage before disconnecting the protective earth (7).
- i** Connect protective earth to the internal ground terminal (7) before connecting the supply voltage. If necessary, connect the potential matching line to the external ground terminal (11).
 - i** In order to ensure electromagnetic compatibility (EMC): Do not only ground the device via the protective earth conductor of the supply cable. Instead, the functional grounding must also be connected to the process connection (flange or threaded connection) or to the external ground terminal.
 - i** An easily accessible power switch must be installed in the proximity of the device. The power switch must be marked as a disconnecter for the device (IEC/EN61010).

Connection examples for the switch output

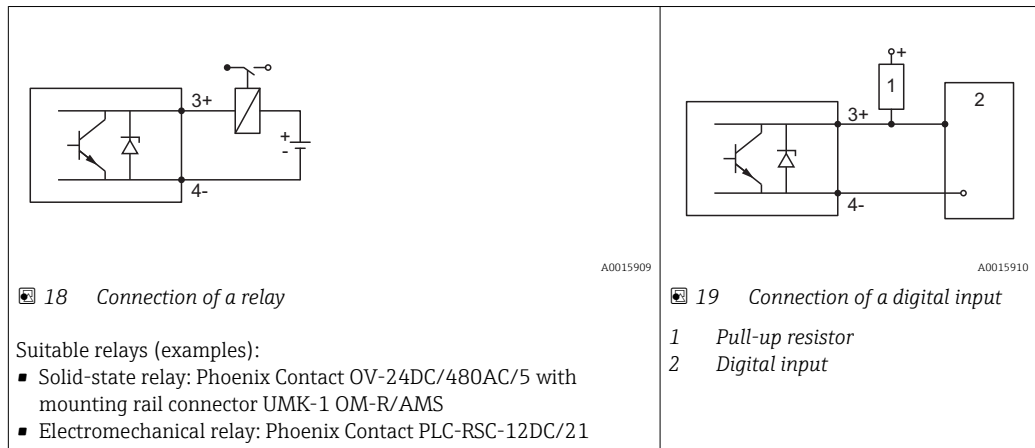

i For optimum interference immunity we recommend to connect an external resistor (internal resistance of the relay or Pull-up resistor) of $< 1\ 000\ \Omega$.

HART loop converter HMX50

The dynamic variables of the HART protocol can be converted into individual 4 to 20 mA sections using the HART loop converter HMX50. The variables are assigned to the current output and the measuring ranges of the individual parameters are defined in the HMX50.

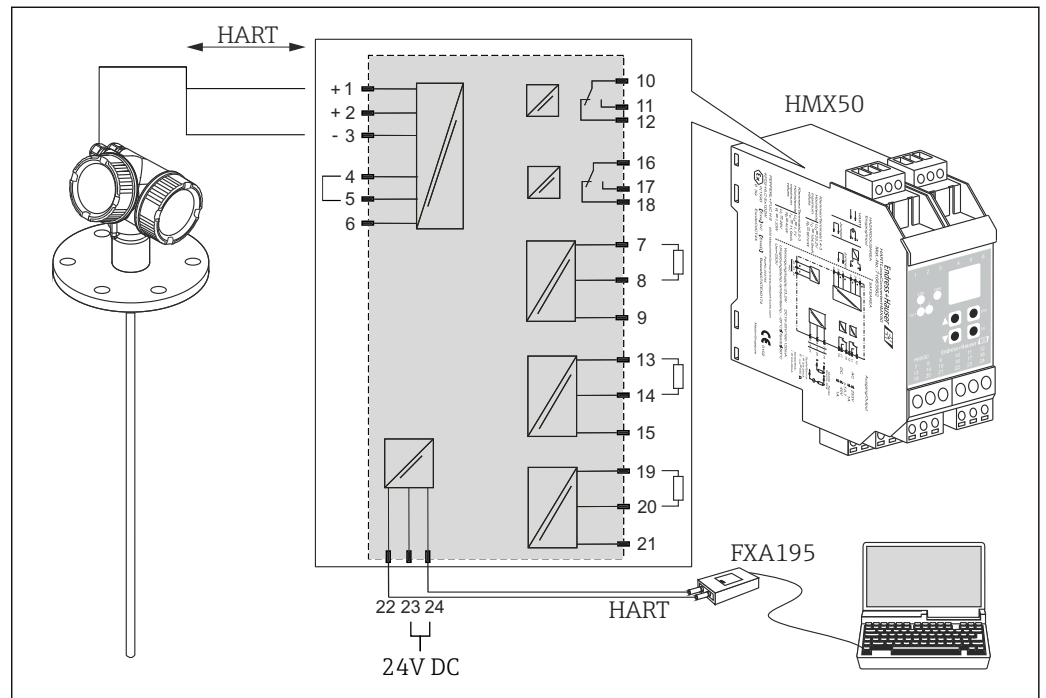

A0023287

20 Connection diagram for HART loop converter HMX50 (example: passive 2-wire device and current outputs connected as power source)

The HART loop converter HMX50 can be acquired using the order number 71063562.

Additional documentation: TI00429F and BA00371F.

7.1.2 Cable specification

- Minimum cross-section: See the "Terminal" specification in the Technical Information for the device.
- For ambient temperature $T_U \geq 60^\circ\text{C}$ (140 °F): use cable for temperature $T_U + 20\text{ K}$.

HART

- A normal device cable suffices if only the analog signal is used.
- A shielded cable is recommended if using the HART protocol. Observe grounding concept of the plant.
- For 4-wire devices: Standard device cable is sufficient for the power line.

7.1.3 Device plug connectors

i For the versions with fieldbus plug connector (M12 or 7/8"), the signal line can be connected without opening the housing.

Pin assignment of the M12 plug connector

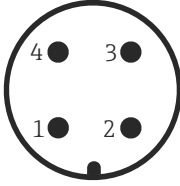
 <small>A0011175</small>	Pin	Meaning
	1	Signal +
	2	not connected
	3	Signal -
	4	Ground

Pin assignment of the 7/8" plug connector

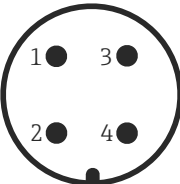
 <small>A0011176</small>	Pin	Meaning
	1	Signal -
	2	Signal +
	3	Not connected
	4	Screen

7.1.4 Power supply

2-wire, 4-20mA HART, passive

2-wire; 4-20mA HART¹⁾

"Approval" ²⁾	Terminal voltage U at the device	Maximum load R, depending on the supply voltage U ₀ at the supply unit
<ul style="list-style-type: none"> ▪ Non-Ex ▪ Ex nA ▪ CSA GP 	11.5 to 35 V ³⁾	<p style="text-align: right; font-size: small;">A0014076</p>
Ex ic	11.5 to 32 V	
Ex ia / IS	11.5 to 30 V	
<ul style="list-style-type: none"> ▪ Ex d / XP ▪ Ex ic[ia] ▪ Ex tD / DIP 	13.5 to 30 V ⁴⁾	<p style="text-align: right; font-size: small;">A0014077</p>

- 1) Feature 020 of the product structure: option A
- 2) Feature 010 of the product structure
- 3) For ambient temperatures $T_a \leq -30\text{ °C}$ (-22 °F) a minimum voltage of 14 V is required for the startup of the device at the MIN error current (3,6 mA). The startup current can be parametrized. If the device is operated with a fixed current $I \geq 4,5\text{ mA}$ (HART multidrop mode), a voltage of $U \geq 11,5\text{ V}$ is sufficient throughout the entire range of ambient temperatures.
- 4) For ambient temperatures $T_a \leq -20\text{ °C}$ (-4 °F) a minimum voltage of 16 V is required for the startup of the device at the MIN error current (3.6 mA).

2-wire; 4-20 mA HART, switch output¹⁾

"Approval" ²⁾	Terminal voltage U at the device	Maximum load R, depending on the supply voltage U ₀ at the supply unit
<ul style="list-style-type: none"> ▪ Non-Ex ▪ Ex nA ▪ Ex nA[ia] ▪ Ex ic ▪ Ex ic[ia] ▪ Ex d[ia] / XP ▪ Ex ta / DIP ▪ CSA GP 	12 to 35 V ³⁾	<p style="text-align: right; font-size: small;">A0019136</p>
<ul style="list-style-type: none"> ▪ Ex ia / IS ▪ Ex ia + Ex d[ia] / IS + XP 	12 to 30 V ³⁾	

- 1) Feature 020 of the product structure: option B
- 2) Feature 010 of the product structure
- 3) For ambient temperatures $T_a \leq -30\text{ °C}$ (-22 °F) a minimum voltage of 14 V is required for the startup of the device at the MIN error current (3.6 mA).

2-wire; 4-20mA HART, 4-20mA ¹⁾

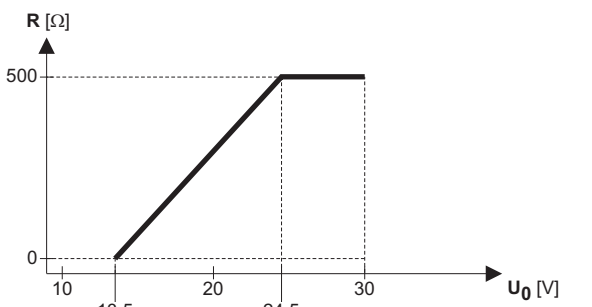
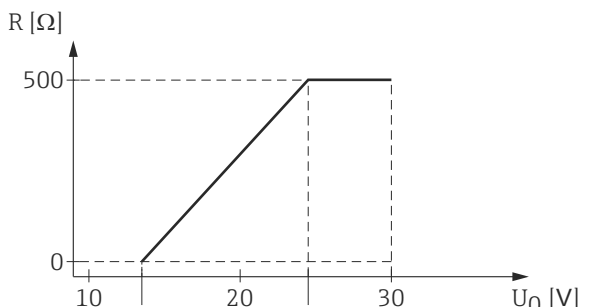
"Approval" ²⁾	Terminal voltage U at the device	Maximum load R, depending on the supply voltage U ₀ at the supply unit
alle	Channel 1: 13,5 to 30 V ³⁾	 <p style="text-align: right; font-size: small;">A0014077</p>
	Channel 2: 12 to 30 V	 <p style="text-align: right; font-size: small;">A0022583</p>

1) Feature 020 of the product structure: option C

2) Feature 010 of the product structure

3) For ambient temperatures $T_a \leq -30\text{ °C}$ (-22 °F) a minimum voltage of 16 V is required for the startup of the device at the MIN error current (3.6 mA).

Polarity reversal protection	Yes
Admissible residual ripple at f = 0 to 100 Hz	$U_{SS} < 1\text{ V}$
Admissible residual ripple at f = 100 to 10000 Hz	$U_{SS} < 10\text{ mV}$

4-wire, 4-20mA HART, active

"Power supply; Output" ¹⁾	Terminal voltage	Maximum load R _{max}
K: 4-wire 90-253VAC; 4-20mA HART	90 to 253 V _{AC} (50 to 60 Hz), overvoltage category II	500 Ω
L: 4-wire 10,4-48VDC; 4-20mA HART	10.4 to 48 V _{DC}	

1) Feature 020 of the product structure

7.1.5 Overvoltage protection

If the measuring device is used for level measurement in flammable liquids which requires the use of overvoltage protection according to DIN EN 60079-14, standard for test procedures 60060-1 (10 kA, pulse 8/20 μs), overvoltage protection has to be ensured by an integrated or external overvoltage protection module.

Integrated overvoltage protection

An integrated overvoltage protection module is available for 2-wire HART as well as PROFIBUS PA and FOUNDATION Fieldbus devices.

Product structure: Feature 610 "Accessory mounted", option NA "Overvoltage protection".

Technical data	
Resistance per channel	2 * 0.5 Ω max
Threshold DC voltage	400 to 700 V
Threshold impulse voltage	< 800 V
Capacitance at 1 MHz	< 1.5 pF
Nominal arrest impulse voltage (8/20 μs)	10 kA

External overvoltage protection

HAW562 or HAW569 from Endress+Hauser are suited as external overvoltage protection.



For detailed information please refer to the following documents:

- HAW562: TI01012K
- HAW569: TI01013K

7.2 Connecting the device**⚠ WARNING****Explosion hazard!**

- ▶ Comply with the relevant national standards.
- ▶ Observe the specifications in the Safety Instructions (XA).
- ▶ Only use the specified cable glands.
- ▶ Check whether the supply voltage matches the specifications on the nameplate.
- ▶ Before connecting the device: Switch the supply voltage off.
- ▶ Before switching on the supply voltage: Connect the potential bonding line to the exterior ground terminal.

Required tools and accessories:

- For instruments with safety pin for the lid: AF 3 Allen key
- Wire stripping pliers
- When using stranded wires: Wire end sleeves.

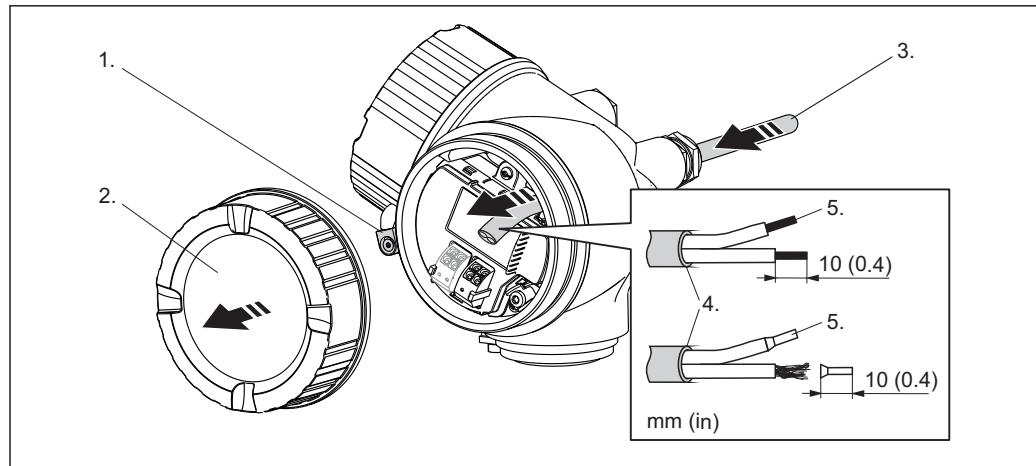

A0012619

1. Loosen the screw of the securing clamp of the connection compartment cover and turn the clamp 90° counterclockwise.
2. Unscrew the connection compartment cover.
3. Push the cable through the cable entry. To ensure tight sealing, do not remove the sealing ring from the cable entry.
4. Strip the cable.
5. Strip the cable ends 10 mm (0.4 in). For stranded cables, also attach wire end ferrules.
6. Firmly tighten the cable glands.

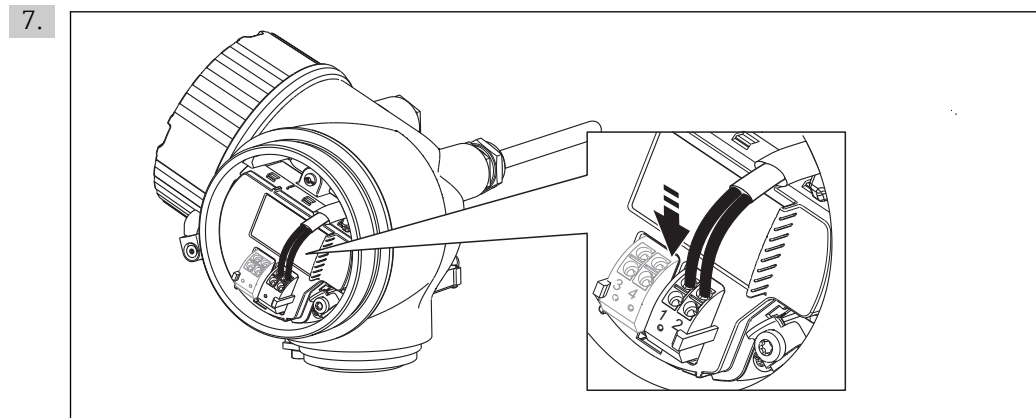

A0013837

Connect the cable in accordance with the terminal assignment → 55.

8. When using screened cable: Connect the cable screen to the ground terminal.
9. Screw the cover onto the connection compartment.
10. For instruments with safety pin for the lid: Adjust the safety pin so that its edge is over the edge of the display lid. Tighten the safety pin.

7.2.1 Pluggable spring-force terminals

Instruments without integrated overvoltage protection have pluggable spring-force terminals. Rigid conductors or flexible conductors with cable sleeve can directly be inserted and are contacted automatically.

To remove cables from the terminal: Press on the groove between the terminals using a flat-tip screwdriver ≤ 3 mm (0.12 inch) while pulling the cables out of the terminals.

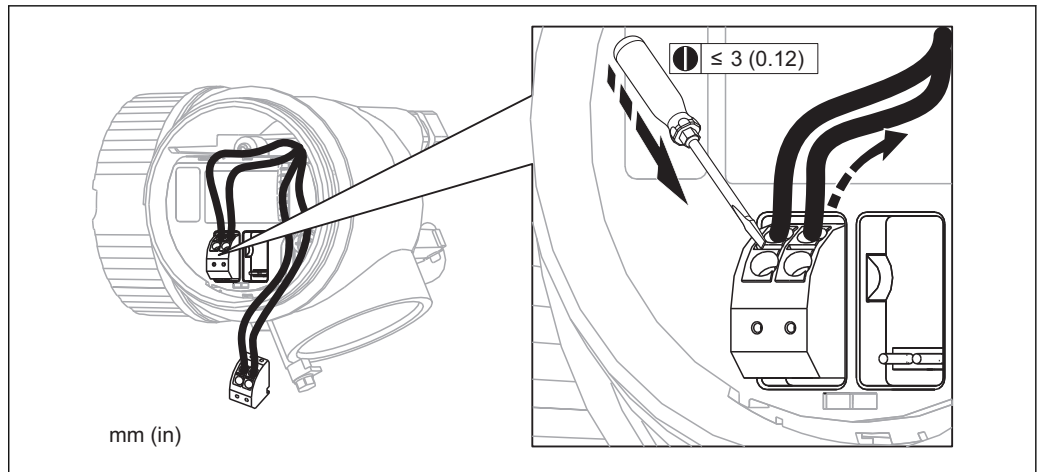

7.3 Post-connection check

<input type="radio"/>	Are cables or the device undamaged (visual inspection)?
<input type="radio"/>	Do the cables comply with the requirements?
<input type="radio"/>	Do the cables have adequate strain relief?
<input type="radio"/>	Are all cable glands installed, firmly tightened and correctly sealed?
<input type="radio"/>	Does the supply voltage match the specifications on the transmitter nameplate?
<input type="radio"/>	Is the terminal assignment correct → 55?
<input type="radio"/>	If required: Is the protective earth connected correctly ?
<input type="radio"/>	If supply voltage is present: Is the device ready for operation and do values appear on the display module?
<input type="radio"/>	Are all housing covers installed and firmly tightened?
<input type="radio"/>	Is the securing clamp tightened correctly?

8 Operation options

8.1 Overview

8.1.1 Local operation

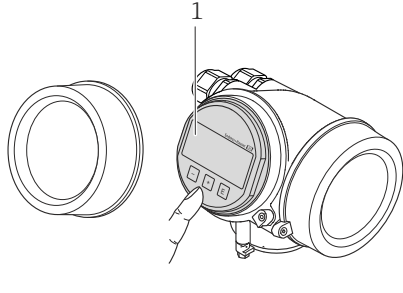
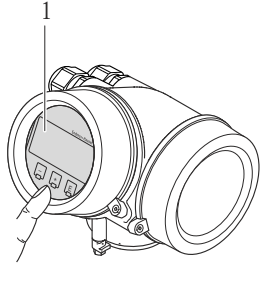
Order code for "Display; Operation", option C "SD02"	Order code for "Display; Operation", option E "SD03"
	
1 Operation with pushbuttons	1 Operation with touch control

8.1.2 Operation with remote display and operating module FHX50

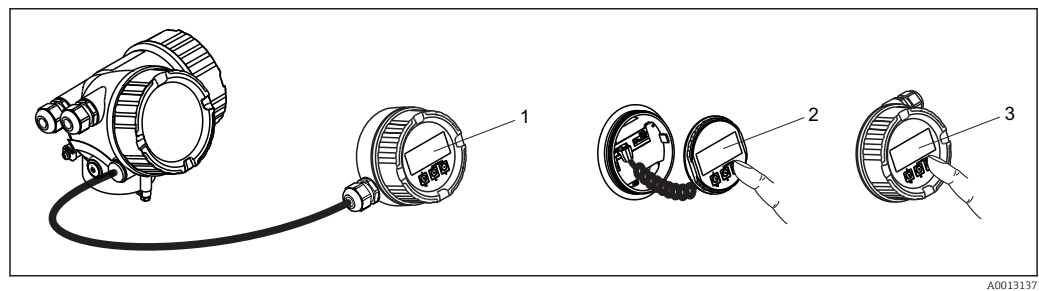

21 FHX50 operating options

- 1 Housing of the remote display and operating module FHX50
- 2 Display and operating module SD02, push buttons; cover must be removed
- 3 Display and operating module SD03, optical keys; can be operated through the glass of the cover

8.1.3 Remote operation

Via HART protocol

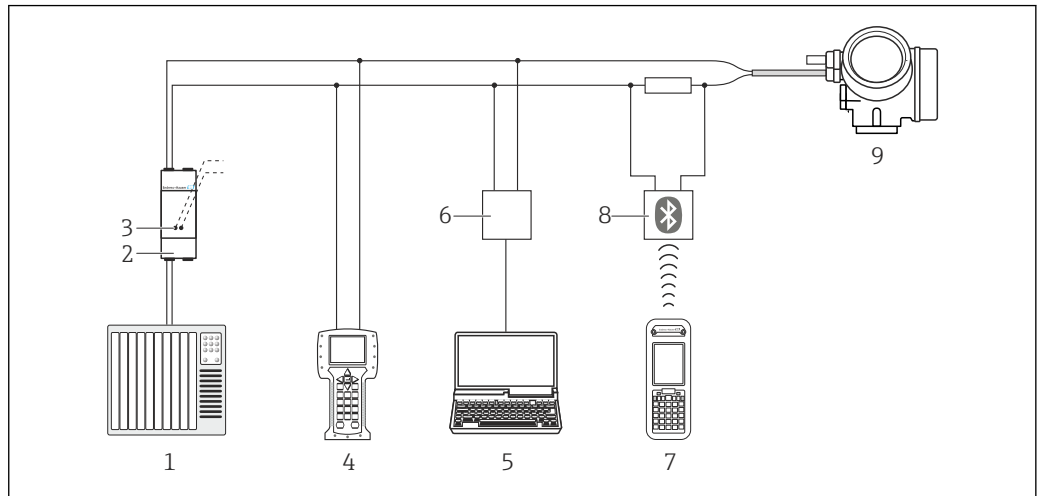

A0013764

22 Options for remote operation via HART protocol

- 1 PLC (programmable logic controller)
- 2 Transmitter power supply unit, e.g. RN221N (with communication resistor)
- 3 Connection for Commubox FXA191, FXA195 and Field Communicator 375, 475
- 4 Field Communicator 475
- 5 Computer with operating tool (e.g. FieldCare, AMS Device Manager, SIMATIC PDM)
- 6 Commubox FXA191 (RS232) or FXA195 (USB)
- 7 Field Xpert SFX350/SFX370
- 8 VIATOR Bluetooth modem with connecting cable
- 9 Transmitter

Via service interface (CDI)

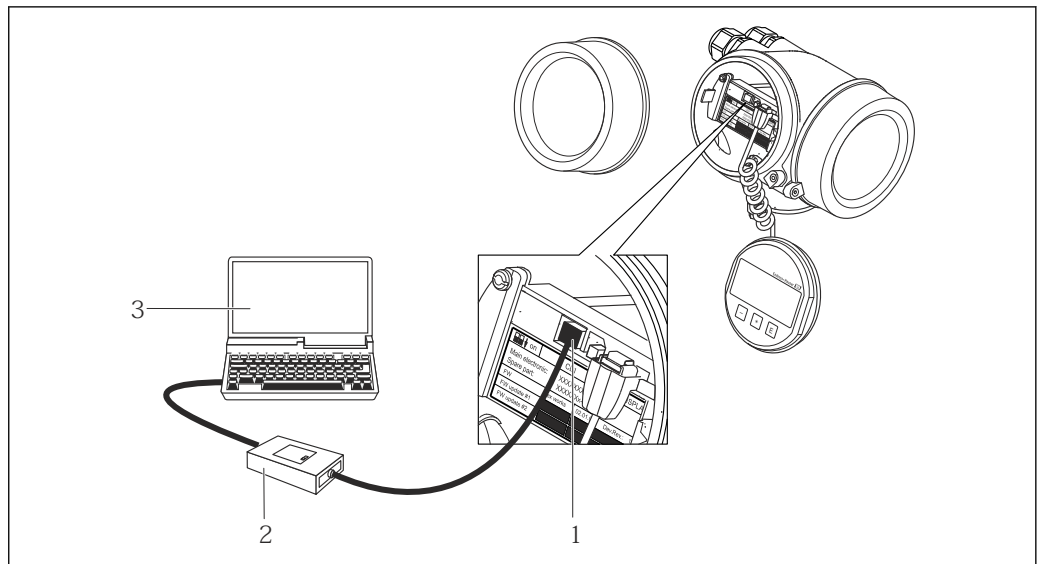

A0014019

- 1 Service interface (CDI) of the measuring device (= Endress+Hauser Common Data Interface)
- 2 Commubox FXA291
- 3 Computer with "FieldCare" operating tool

8.2 Structure and function of the operating menu

8.2.1 Structure of the operating menu

Menu	Submenu / parameter	Meaning
	Language ¹⁾	Defines the operating language of the on-site display.
Commissioning ²⁾		Opens the interactive wizard for a guided commissioning of the device. As a rule, no additional settings in the other menus are required after the completion of the wizard.
Setup	Parameter 1 ... Parameter N	When all these parameters have been assigned appropriate values, the measured should be completely configured in a standard application.
	Advanced setup	Contains further submenus and parameters: <ul style="list-style-type: none"> ▪ to adapt the device to special measuring conditions. ▪ to process the measured value (scaling, linearization). ▪ to configure the signal output.
Diagnostics	Diagnostic list	Contains up to 5 currently active error messages.
	Event logbook ³⁾	Contains the last 20 messages (which are no longer active).
	Device information	Contains information needed to identify the device.
	Measured values	Contains all current measured values.
	Data logging	Contains the history of the individual measuring values.
	Simulation	Used to simulate measured values or output values.
	Device check	Contains all parameters needed to check the measurement capability of the device.
Expert ⁴⁾ Contains all parameters of the device (including those which are already contained in one of the above submenus). This menu is organized according to the function blocks of the device. The parameter of the Expert menu are described in: GPO1014F (HART)	System	Contains all general device parameters which do not affect the measurement or the communication interface.
	Sensor	Contains all parameters needed to configure the measurement.
	Output	<ul style="list-style-type: none"> ▪ Contains all parameters needed to configure the current output. ▪ Contains all parameters needed to configure the switch output (PFS).
	Communication	Contains all parameters needed to configure the digital communication interface.
	Diagnostics	Contains all parameters needed to detect and analyze operational errors.

- 1) In case of operation via operating tools (e.g. FieldCare), the "Language" parameter is located at "Setup → Advanced setup → Display"
- 2) only for operation via a FDT/DTM system
- 3) only available with local operation
- 4) On entering the "Expert" menu, an access code is always requested. If a customer specific access code has not been defined, "0000" has to be entered.

8.2.2 User roles and related access authorization

The two user roles **Operator** and **Maintenance** have different write access to the parameters if a device-specific access code has been defined. This protects the device configuration via the local display from unauthorized access →  72.

Access authorization to parameters

User role	Read access		Write access	
	Without access code (from the factory)	With access code	Without access code (from the factory)	With access code
Operator	✓	✓	✓	--
Maintenance	✓	✓	✓	✓

If an incorrect access code is entered, the user obtains the access rights of the **Operator** role.

 The user role with which the user is currently logged on is indicated by the **Access status display** parameter (for display operation) or **Access status tooling** parameter (for tool operation).

8.2.3 Write protection via access code

Using the device-specific access code, the parameters for the measuring device configuration are write-protected and their values can no longer be changed via local operation.

Define access code via local display

1. Navigate to: Setup → Advanced setup → Administration → Define access code → Define access code
2. Define a max. 4-digit numeric code as an access code.
3. Repeat the same code in **Confirm access code** parameter.
 - ↳ The -symbol appears in front of all write-protected parameters.



Define access code via operating tool (e.g. FieldCare)

1. Navigate to: Setup → Advanced setup → Administration → Define access code
2. Define a max. 4-digit numeric code as an access code.
 - ↳ Write protection is active.



Parameters that can always be changed

The write protection does not include certain parameters that do not affect the measurement. Despite the defined access code, they can always be modified, even if the other parameters are locked.



If no key is pressed for 10 minutes in the navigation and editing mode, the device automatically locks the write-protected parameters. If the user goes from the navigation and editing mode back to the measured value display mode, the device automatically locks the write-protected parameters after 60 s.

-  If write access is activated via access code, it can be also be deactivated only via the access code →  73.
- In the "Description of Device Parameters" documents, each write-protected parameter is identified with the -symbol.

8.2.4 Disabling write protection via access code

If the -symbol appears on the local display in front of a parameter, the parameter is write-protected by a device-specific access code and its value cannot be changed at the moment using the local display →  72.

The locking of the write access via local operation can be disabled by entering the device-specific access code.

1. After you press , the input prompt for the access code appears.
2. Enter the access code.
 - ↳ The -symbol in front of the parameters disappears; all previously write-protected parameters are now re-enabled.

8.2.5 Deactivation of the write protection via access code

Via local display

1. Navigate to Setup → Advanced setup → Administration → Define access code → Define access code
2. Enter **0000**.
3. Repeat **0000** in **Confirm access code** parameter.
 - ↳ The write protection is deactivated. Parameters can be changed without entering an access code.

Via operating tool (e.g. FieldCare)

1. Navigate to Setup → Advanced setup → Administration → Define access code
2. Enter **0000**.
 - ↳ The write protection is deactivated. Parameters can be changed without entering an access code.

8.2.6 Write protection via write protection switch

Unlike write protection via a user-specific access code, this allows write access to the entire operating menu - other than the **"Contrast display" parameter** - to be locked.

The parameter values are now read only and cannot be edited any more (exception **"Contrast display" parameter**):

- Via local display
- Via service interface (CDI)
- Via HART protocol

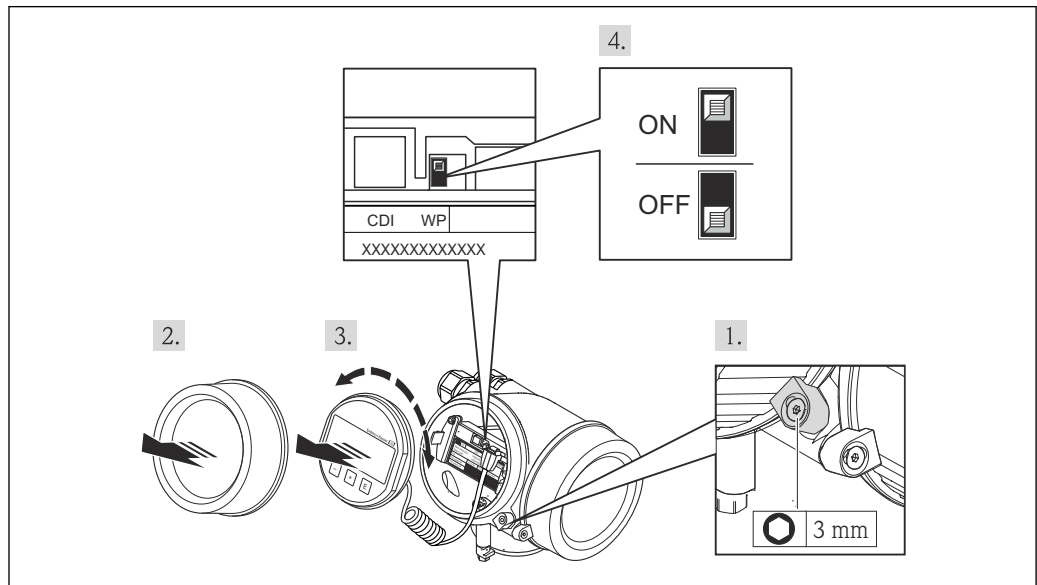

A0026157

1. Loosen the securing clamp.
2. Unscrew the housing cover.
3. Pull out the display module with a gentle rotation movement. To make it easier to access the lock switch, attach the display module to the edge of the electronics compartment.
 - ↳ Display module is attached to the edge of the electronics compartment.

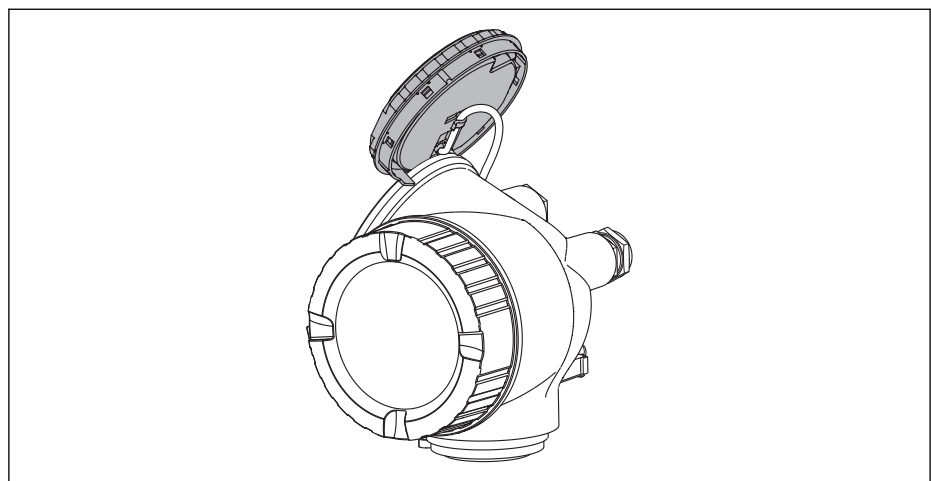

A0013909

4. Installing the lock switch (WP) on the main electronics module in the **ON** position enables the hardware write protection. Installing the lock switch (WP) on the main electronics module in the **OFF** position (factory setting) disables the hardware write protection.
 - ↳ If the hardware write protection is enabled: The **Hardware locked** option is displayed in the **Locking status** parameter. In addition to this, the -symbol appears in the header of the measured value display and in the navigation view in front of the parameters.

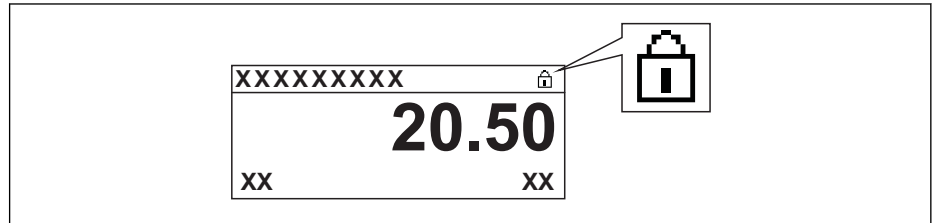

A0015870

If the hardware write protection is disabled: No option is displayed in the **Locking status** parameter. The -symbol disappears in the header of the measured value display and in the navigation view in front of the parameters.

5. Feed the spiral cable into the gap between the housing and main electronics module and plug the display module into the electronics compartment in the desired direction until it engages.
6. Screw the electronics compartment cover closed and tighten the securing clamp.

8.2.7 Enabling and disabling the keypad lock

The keypad lock allows to disable access to the entire operating menu via local operation. Thus navigating through the operating menu or modifying the values of individual parameters is no longer possible. Only the measured values on the measured value display can be read off.

The keylock is enabled and disabled via a context menu.

Enabling the keylock



For the SD03 display:

The keylock is automatically activated:

- If the device has not been operated via the display for > 1 minute.
- After a restart of the device.

To activate the keylock manually:

1. The device is in the measured value display.
Press \square for at least 2 seconds.
↳ A context menu appears.
2. Select **Keylock on** from the context menu.
↳ The keylock is enabled.



When attempting to access the operating menu while the keylock is enabled, the **Keylock on** message appears.

Disabling the keylock

1. The keylock is enabled.
Press \square for at least 2 seconds.
↳ A context menu appears.
2. Select **Keylock off** from the context menu.
↳ The keylock is disabled.

8.3 Display and operating module

8.3.1 Display appearance

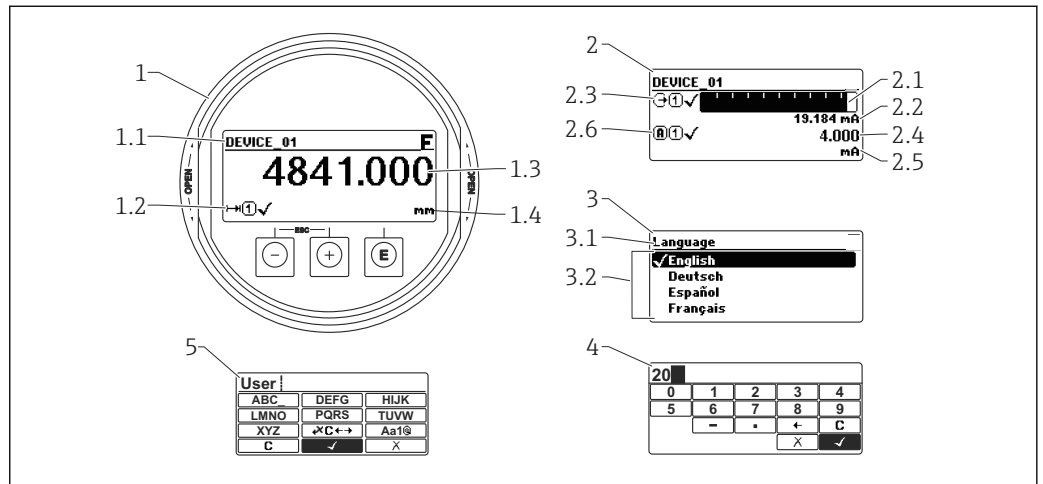





A0012635

23 Appearance of the display and operation module for on-site operation

- 1 Measured value display (1 value max. size)
- 1.1 Header containing tag and error symbol (if an error is active)
- 1.2 Measured value symbols
- 1.3 Measured value
- 1.4 Unit
- 2 Measured value display (1 bargraph + 1 value)
- 2.1 Bargraph for measured value 1
- 2.2 Measured value 1 (including unit)
- 2.3 Measured value symbols for measured value 1
- 2.4 Measured value 2
- 2.5 Unit for measured value 2
- 2.6 Measured value symbols for measured value 2
- 3 Representation of a parameter (here: a parameter with selection list)
- 3.1 Header containing parameter name and error symbol (if an error is active)
- 3.2 Selection list; marks the current parameter value.
- 4 Input matrix for numbers
- 5 Input matrix for alphanumeric and special characters



Display symbols for the submenus

Symbol	Meaning
 A0011975	Display/operation Is displayed: <ul style="list-style-type: none"> in the main menu next to the selection "Display/operation" in the header, if you are in the "Display/operation" menu
 A0011974	Setup Is displayed: <ul style="list-style-type: none"> in the main menu next to the selection "Setup" in the header, if you are in the "Setup" menu
 A0011976	Expert Is displayed: <ul style="list-style-type: none"> in the main menu next to the selection "Expert" in the header, if you are in the "Expert" menu
 A0011977	Diagnostics Is displayed: <ul style="list-style-type: none"> in the main menu next to the selection "Diagnostics" in the header, if you are in the "Diagnostics" menu











Status signals

F A0013956	"Failure" A device error is present. The measured value is no longer valid.
C A0013959	"Function check" The device is in service mode (e.g. during a simulation).
S A0013958	"Out of specification" The device is operated: <ul style="list-style-type: none"> Outside of its technical specifications (e.g. during startup or a cleaning) Outside of the configuration carried out by the user (e.g. level outside configured span)
M A0013957	"Maintenance required" Maintenance is required. The measured value is still valid.







Display symbols for the locking state

Symbol	Meaning
 A0011978	Display parameter Marks display-only parameters which can not be edited.
 A0011979	Device locked <ul style="list-style-type: none"> In front of a parameter name: The device is locked via software and/or hardware. In the header of the measured value screen: The device is locked via hardware.

Measured value symbols

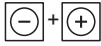
Symbol	Meaning
Measured values	
 A0011995	Level
 A0011996	Distance
 A0011998	Current output
 A0011999	Measured current
 A0012106	Terminal voltage
 A0012104	Temperature of the electronics or the sensor
Measuring channels	
 A0012000	Measuring channel 1
 A0012107	Measuring channel 2
Status of the measured value	
 A0012102	Status "Alarm" The measurement is interrupted. The output assumes the defined alarm value. A diagnostic message is generated.
 A0012103	Status "Warning" The device continues measuring. A diagnostic message is generated.

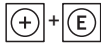
8.3.2 Operating elements

Key	Meaning
 A0013969	<p>Minus key</p> <p><i>For menu, submenu</i> Moves the selection bar upwards in a picklist.</p> <p><i>For text and numeric editor</i> In the input mask, moves the selection bar to the left (backwards).</p>
 A0013970	<p>Plus key</p> <p><i>For menu, submenu</i> Moves the selection bar downwards in a picklist.</p> <p><i>For text and numeric editor</i> In the input mask, moves the selection bar to the right (forwards).</p>
 A0013952	<p>Enter key</p> <p><i>For measured value display</i></p> <ul style="list-style-type: none"> ▪ Pressing the key briefly opens the operating menu. ▪ Pressing the key for 2 s opens the context menu. <p><i>For menu, submenu</i></p> <ul style="list-style-type: none"> ▪ Pressing the key briefly Opens the selected menu, submenu or parameter. ▪ Pressing the key for 2 s for parameter: If present, opens the help text for the function of the parameter. <p><i>For text and numeric editor</i></p> <ul style="list-style-type: none"> ▪ Pressing the key briefly <ul style="list-style-type: none"> - Opens the selected group. - Carries out the selected action. ▪ Pressing the key for 2 s confirms the edited parameter value.
 A0013971	<p>Escape key combination (press keys simultaneously)</p> <p><i>For menu, submenu</i></p> <ul style="list-style-type: none"> ▪ Pressing the key briefly <ul style="list-style-type: none"> - Exits the current menu level and takes you to the next higher level. - If help text is open, closes the help text of the parameter. ▪ Pressing the key for 2 s returns you to the measured value display ("home position"). <p><i>For text and numeric editor</i> Closes the text or numeric editor without applying changes.</p>
 A0013953	<p>Minus/Enter key combination (press and hold down the keys simultaneously)</p> <p>Reduces the contrast (brighter setting).</p>
 A0013954	<p>Plus/Enter key combination (press and hold down the keys simultaneously)</p> <p>Increases the contrast (darker setting).</p>
 A0013955	<p>Minus/Plus/Enter key combination (press and hold down the keys simultaneously)</p> <p><i>For measured value display</i> Enables or disables the keypad lock.</p>



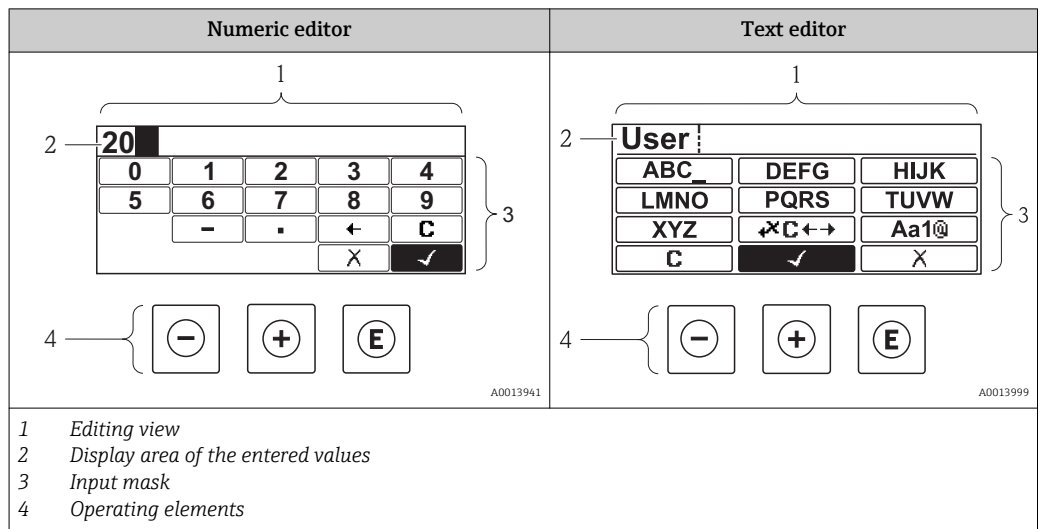

8.3.3 Entering numbers and text





Input mask



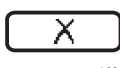
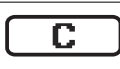

The following input symbols are available in the input mask of the numeric and text editor:

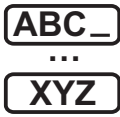



Numeric editor symbols

Symbol	Meaning
 A0013998	Selection of numbers from 0 to 9.
 A0016619	Inserts decimal separator at the input position.
 A0016620	Inserts minus sign at the input position.
 A0013985	Confirms selection.
 A0016621	Moves the input position one position to the left.
 A0013986	Exits the input without applying the changes.
 A0014040	Clears all entered characters.

Text editor symbols

Symbol	Meaning
 A0013997	Selection of letters from A to Z
 A0013981	Toggle <ul style="list-style-type: none"> Between upper-case and lower-case letters For entering numbers For entering special characters

 <small>A0013985</small>	Confirms selection.
 <small>A0013987</small>	Switches to the selection of the correction tools.
 <small>A0013986</small>	Exits the input without applying the changes.
 <small>A0014040</small>	Clears all entered characters.

Correction symbols under 	
 <small>A0013989</small>	Clears all entered characters.
 <small>A0013991</small>	Moves the input position one position to the right.
 <small>A0013990</small>	Moves the input position one position to the left.
 <small>A0013988</small>	Deletes one character immediately to the left of the input position.

8.3.4 Opening the context menu

Using the context menu, the user can call up the following menus quickly and directly from the operational display:

- Setup
- Conf. backup disp.
- Simulation



Calling up and closing the context menu

The user is in the operational display.

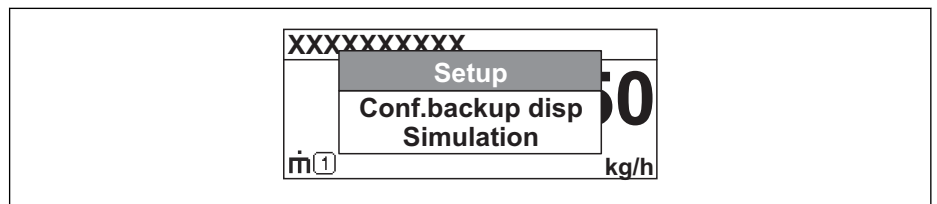

1. Press  for 2 s.
 - ↳ The context menu opens.



A0014003-EN

2. Press  +  simultaneously.
 - ↳ The context menu is closed and the operational display appears.

Calling up the menu via the context menu

1. Open the context menu.
2. Press  to navigate to the desired menu.
3. Press  to confirm the selection.
 - ↳ The selected menu opens.

8.3.5 Envelope curve on the display and operating module

In order to assess the measuring signal, the envelope curve and - if a mapping has been recorded - the mapping curve can be displayed:

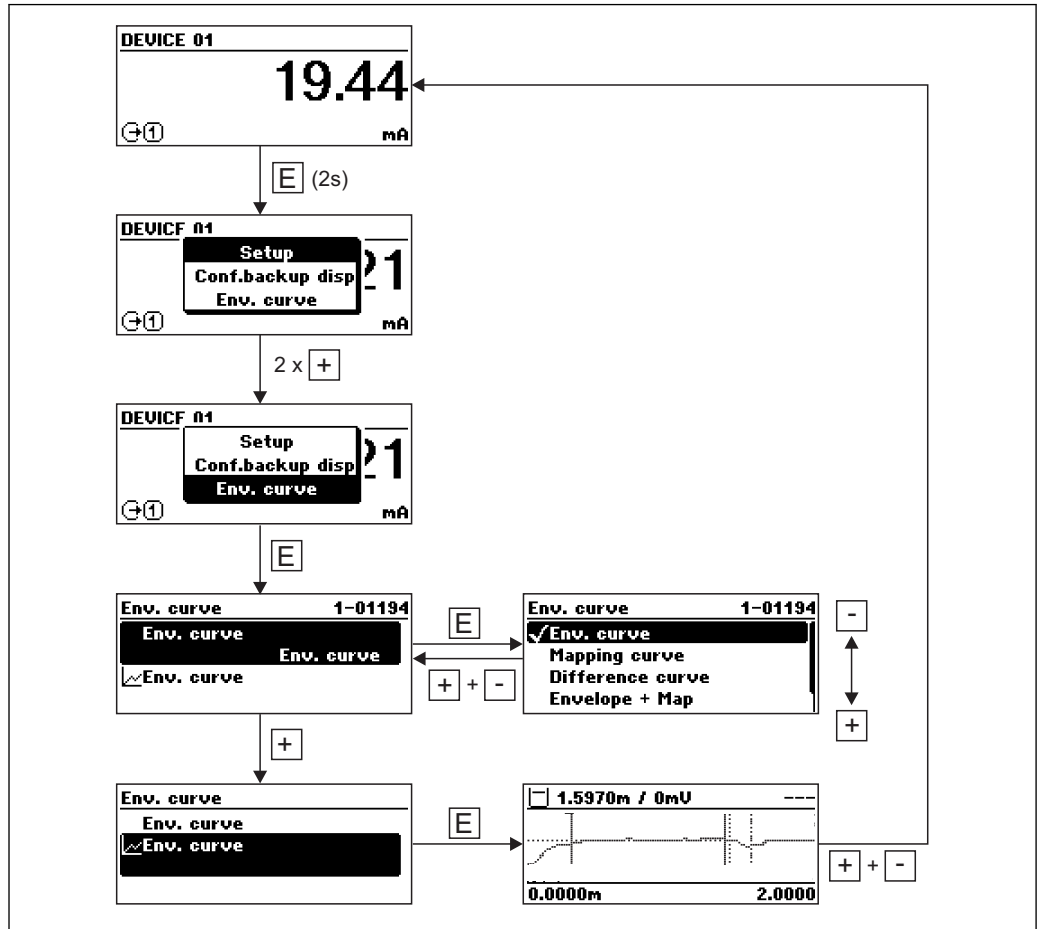

A0014277

9 Device integration via the HART protocol

9.1 Overview of the Device Description files (DD)

HART

Manufacturer ID	0x11
Device type	0x1122
HART specification	7.0
DD files	For information and files see: <ul style="list-style-type: none"> ▪ www.endress.com ▪ www.hartcomm.org

9.2 HART device variables and measuring values

On delivery the following measuring values are assigned to the HART device variables:

Device variables for level measurements

Device variable	Measuring value
Primary variable (PV)	Level linearized
Secondary variable (SV)	Unfiltered distance
Tertiary variable (TV)	Absolute echo amplitude
Quaternary variable (QV)	Relative echo amplitude

Device variables for interface measurements

Device variable	Measuring value
Primary variable (PV)	Interface linearized
Secondary variable (SV)	Level linearized
Tertiary variable (TV)	Thickness upper layer
Quaternary variable (QV)	Absolute interface amplitude

 The allocation of the measuring values to the device variables can be changed in the following submenu:

Expert → Communication → Output

10 Commissioning via wizard

A wizard guiding the user through the initial setup is available in FieldCare and DeviceCare.

1. Connect the device to FieldCare or DeviceCare →  69.
2. Open the device in FieldCare or DeviceCare.
 - ↳ The dashboard (home page) of the device appears:

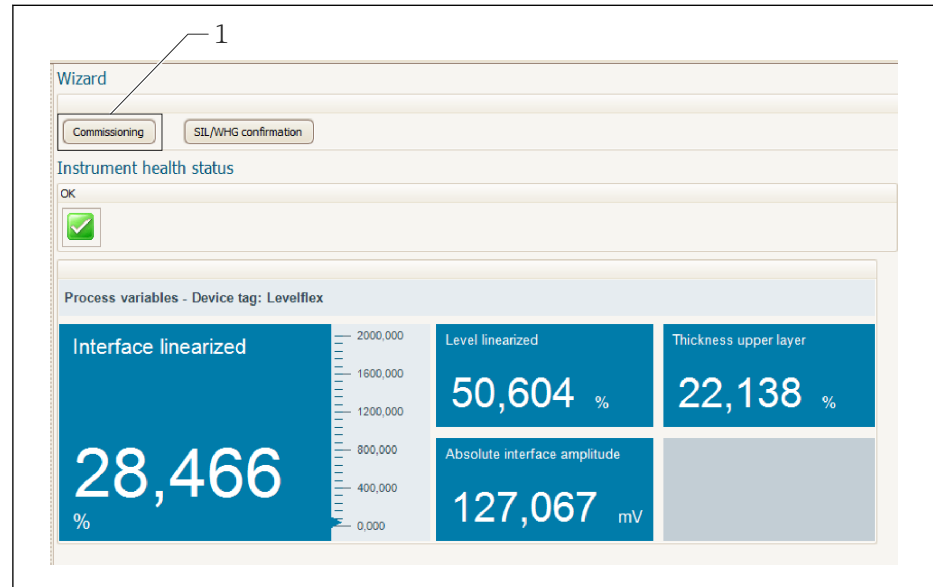

1 "Commissioning" button calls up the wizard.

3. Click on "Commissioning" to call up the wizard.
 4. Enter or select the appropriate value for each parameter. These values are immediately written to the device.
 5. Click "Next" to switch to the next page.
 6. After finishing the last page, click "End of sequence" to close the wizard.
- i** If the wizard is cancelled before all necessary parameters have been set, the device may be in an undefined state. A reset to the default settings is recommended in this case.

11 Commissioning via operating menu

11.1 Installation and function check

Make sure that all final checks have been completed before you start up your measuring point:

- Checklist "Post-installation check" → 54
- Checklist "Post-connection check" → 67

11.2 Setting the operating language

Factory setting: English or ordered local language

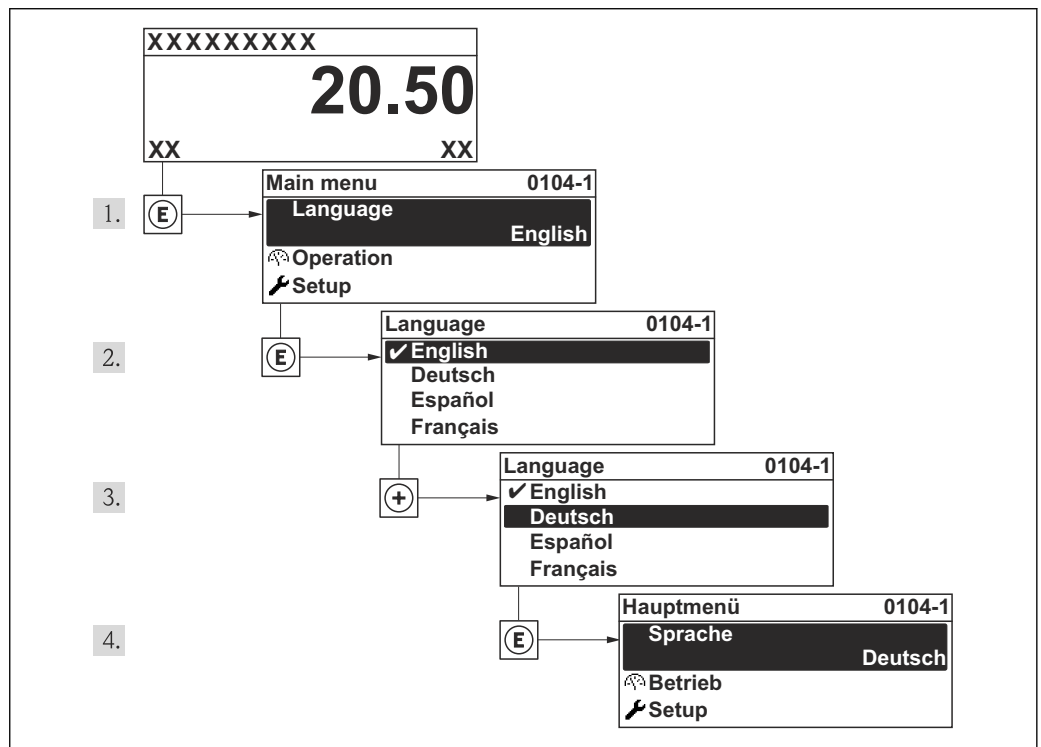

24 Using the example of the local display

A0013996

11.3 Checking the reference distance

i This section is only valid for FMP54 with gas phase compensation (product structure: feature 540 "Application Package", option EF or EG).

Coax probes with gas phase compensation are calibrated on delivery. Rod probes, on the other hand, must be recalibrated after mounting:

After mounting the rod probe in the stilling well or bypass, check and - if necessary - correct the setting of the reference distance in the unpressurized state. Whilst doing so the

level should be at least 200 mm below the reference distance L_{ref} to achieve maximum accuracy.

Step	Parameter	Action
1	Expert → Sensor → Gas phase compensation → GPC mode	Select the On option, in order to activate gas phase compensation.
2	Expert → Sensor → Gas phase compensation → Present reference distance	Check whether the displayed reference distance matches the nominal value (300 mm or 550 mm, respectively; see the nameplate). If yes: no further actions required. If no: continue with step 3.
3	Expert → Sensor → Gas phase compensation → Reference distance	Enter the value displayed in Present reference distance parameter.

 For a detailed description of all parameters concerning the gas phase compensation see:

GP01000F, "Levelflex - Description of device parameters - HART"

11.4 Configuration of a level measurement

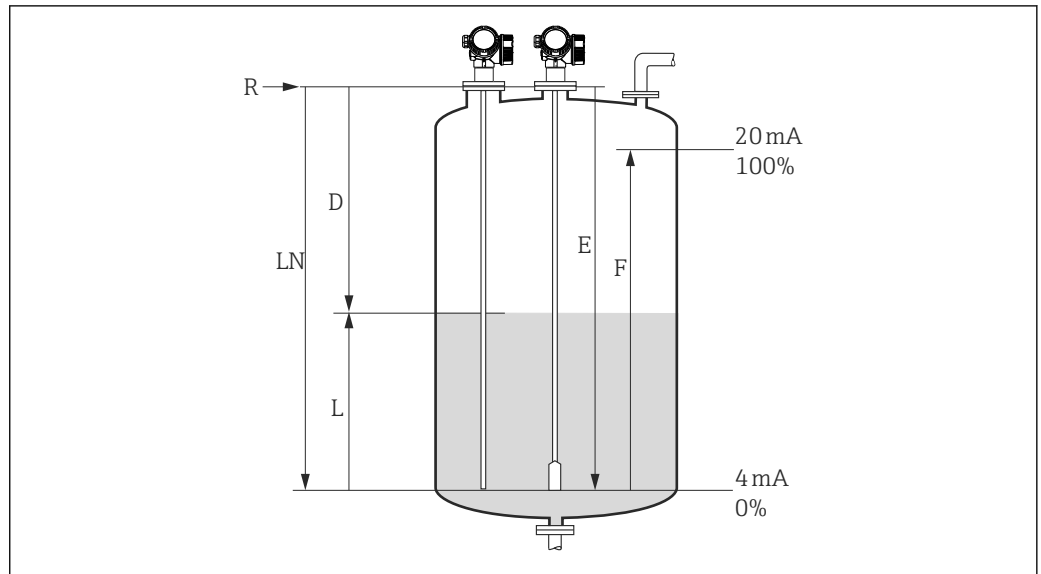

25 Configuration parameters for level measurements in liquids

- LN Length of probe
 R Reference point of the measurement
 D Distance
 L Level
 E Empty calibration (= Zero point)
 F Full calibration (= Span)

i If for rope probes the DC value is less than 7, then measurement is not possible in the area of the straining weight. In these cases, the maximum recommended value for the empty calibration E is $LN - 250 \text{ mm}$ ($LN - 10 \text{ in}$).

1. Setup → Device tag
 - ↳ Enter tag for measuring point.
2. For devices with "interface measurement" application package:
 - Navigate to: Setup → Operating mode
 - ↳ Select **Level** option.
3. Navigate to: Setup → Distance unit
 - ↳ Select distance unit.
4. Navigate to: Setup → Tank type
 - ↳ Select tank type.
5. For Tank type = Bypass / pipe:
 - Navigate to: Setup → Tube diameter
 - ↳ Enter the diameter of the bypass or stilling well.
6. Navigate to: Setup → Medium group
 - ↳ Select medium group: (**Water based (DC >= 4)** or **Others**)
7. Navigate to: Setup → Empty calibration
 - ↳ Enter the distance E between the reference point R and the minimum level (0%).
8. Navigate to: Setup → Full calibration
 - ↳ Enter distance F between the minimum (0%) and maximum (100%) level.
9. Navigate to: Setup → Level
 - ↳ Displays the measured level L.

10. Navigate to: Setup → Distance
 - ↳ Displays the distance D between the reference point R and the level L.
11. Navigate to: Setup → Signal quality
 - ↳ Displays the signal quality of the level echo.
12. For operation via local display:
Navigate to: Setup → Mapping → Confirm distance
 - ↳ Compare the displayed distance to the real distance in order to start the recording of the mapping curve if required ³⁾.
13. For operation via operating tool:
Navigate to: Setup → Confirm distance
 - ↳ Compare the displayed distance to the real distance in order to start the recording of the mapping curve if required ³⁾.

3) For FMP54 with gas phase compensation (product structure: feature 540 "Application Package", option EF or EG) a map must NOT be recorded.

11.5 Configuration of an interface measurement

i Only devices with the respective software option can be used for interface measurements. This option is selected in the product structure: Feature 540 "Application package", option EB "Interface measurement".

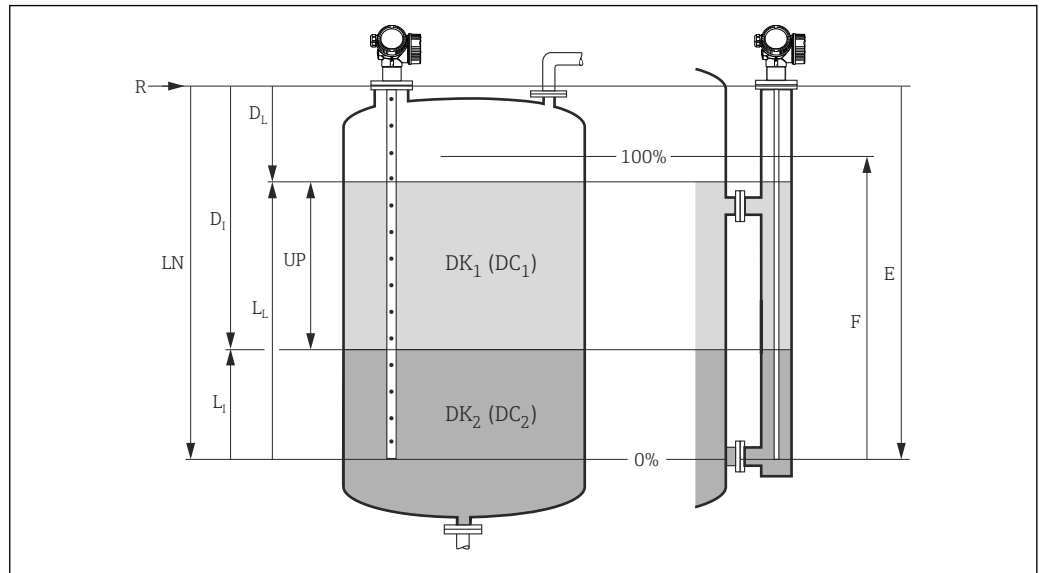

26 Configuration parameters for interface measurements

LN Length of probe
 R Reference point of the measurement
 DI "Interface distance" parameter (Distance from reference point to lower medium)
 LI Interface
 DL Distance
 LL Level
 UP Thickness upper layer
 E "Empty calibration" parameter (= zero point)
 F "Full calibration" parameter (= span)

1. Navigate to: Setup → Device tag
 ↳ Enter tag for measuring point.
2. Navigate to: Setup → Operating mode
 ↳ Select **Interface** option.
3. Navigate to: Setup → Distance unit
 ↳ Select distance unit.
4. Navigate to: Setup → Tank type
 ↳ Select tank type.
5. For Tank type = Bypass / pipe:
 Navigate to: Setup → Tube diameter
 ↳ Enter the diameter of the bypass or stilling well.
6. Navigate to: Setup → Tank level
 ↳ Select tank level (**Fully flooded** or **Partially filled**)
7. Navigate to: Setup → Distance to upper connection
 ↳ In bypasses: Enter distance from reference point R to lower edge of the upper connection; otherwise: Keep the factory setting
8. Navigate to: Setup → DC value
 ↳ Enter relative dielectric constant (ϵ_r) of the upper medium.

9. Navigate to: Setup → Empty calibration
 - ↳ Enter the distance E between the reference point R and the minimum level (0%).
10. Navigate to: Setup → Full calibration
 - ↳ Enter distance F between the minimum (0%) and maximum (100%) level.
11. Navigate to: Setup → Level
 - ↳ Displays the measured level L_L .
12. Navigate to: Setup → Interface
 - ↳ Displays the interface height L_I .
13. Navigate to: Setup → Distance
 - ↳ Displays the distance D_L between the reference point R and the level L_L .
14. Navigate to: Setup → Interface distance
 - ↳ Displays the distance D_I between the reference point R and the interface L_I .
15. Navigate to: Setup → Signal quality
 - ↳ Displays the signal quality of the level echo.
16. For operation via local display:
Navigate to: Setup → Mapping → Confirm distance
 - ↳ Compare the displayed distance to the real distance in order to start the recording of the mapping curve if required ⁴⁾.
17. For operation via operating tool (e.g. FieldCare):
Navigate to: Setup → Confirm distance
 - ↳ Angezeigte Distanz mit tatsächlichem Wert vergleichen, um gegebenenfalls die Aufnahme einer Störechoausblendungskurve zu starten ⁴⁾.

4) For FMP54 with gas phase compensation (product structure: feature 540 "Application Package", option EF or EG) a map must NOT be recorded.

11.6 Recording the reference curve



After the configuration of the measurement it is recommended to record the current envelope curve as a reference curve. The reference curve can be used later on in the process for diagnostic purposes. To record the reference curve use the **Save reference curve** parameter.

Navigation in the menu

Expert → Diagnostics → Envelope diagnostics → Save reference curve

Meaning of the options

- No
No action
- Yes
The current envelope curve is saved as reference curve.

-  In devices which have been delivered with software version 01.00.zz or 01.01.zz, this submenu is only visible for the "Service" user role.
-  The reference curve can only be displayed in the envelope curve diagram of FieldCare after it has been loaded from the device into FieldCare. This is performed by the "Load Reference Curve" function in FieldCare:

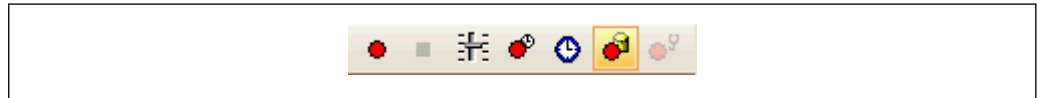

 27 The "Load Reference Curve" function

11.7 Configuration of the on-site display

11.7.1 Factory settings of the on-site display for level measurements

Parameter	Factory setting for devices with 1 current output	Factory setting for devices with 2 current outputs
Format display	1 value, max. size	1 value, max. size
Value 1 display	Level linearized	Level linearized
Value 2 display	Distance	Distance
Value 3 display	Current output 1	Current output 1
Value 4 display	None	Current output 2

11.7.2 Factory settings of the on-site display for interface measurements

Parameter	Factory setting for devices with 1 current output	Factory setting for devices with 2 current outputs
Format display	1 value, max. size	1 value, max. size
Value 1 display	Interface linearized	Interface linearized
Value 2 display	Level linearized	Level linearized
Value 3 display	Thickness upper layer	Current output 1
Value 4 display	Current output 1	Current output 2

11.7.3 Adjustment of the on-site display

The on-site display can be adjusted in the following menu:
Setup → Advanced setup → Display

11.8 Configuration of the current outputs

11.8.1 Factory setting of the current outputs for level measurements

Current output	Allocated measuring value	4mA value	20mA value
1	Level linearized	0% or the corresponding linearized value	100% or the corresponding linearized value
2 ¹⁾	Relative echo amplitude	0 mV	2 000 mV

1) for devices with 2 current outputs

11.8.2 Factory setting of the current outputs for interface measurements

Current output	Allocated measuring value	4mA value	20mA value
1	Interface linearized	0% or the corresponding linearized value	100% or the corresponding linearized value
2 ¹⁾	Level linearized	0% or the corresponding linearized value	100% or the corresponding linearized value

1) for devices with 2 current outputs

11.8.3 Adjustment of the current outputs

The current outputs can be adjusted in the following submenus:

Basic settings

Setup → Advanced setup → Current output 1 to 2

Advanced settings

Expert → Output 1 to 2 → Current output 1 to 2

See "Description of Device Parameters" GP01000F

11.9 Configuration management

After commissioning, you can save the current device configuration, copy it to another measuring point or restore the previous device configuration. You can do so using the **Configuration management** parameter and its options.

Navigation path in the operating menu

Setup → Advanced setup → Configuration backup display → Configuration management

Meaning of the options

- **Cancel**

No action is executed and the user exits the parameter.

- **Execute backup**

A backup copy of the current device configuration in the HistoROM (built-in in the device) is saved to the display module of the device. The backup copy comprises the transmitter and sensor data of the device.

- **Restore**

The last backup copy of the device configuration is copied from the display module to the HistoROM of the device. The backup copy comprises the transmitter and sensor data of the device.

- **Duplicate**

The transmitter configuration is duplicated to another device using the transmitter display module. The following parameters, which characterize the individual measuring point are **not** included in the transmitted configuration:

- HART date code
- HART short tag
- HART message
- HART descriptor
- HART address
- Device tag
- Medium type



- **Compare**

The device configuration saved in the display module is compared to the current device configuration of the HistoROM. The result of this comparison is displayed in the **Comparison result** parameter.

- **Clear backup data**

The backup copy of the device configuration is deleted from the display module of the device.



 While this action is in progress, the configuration cannot be edited via the local display and a message on the processing status appears on the display.

 If an existing backup is restored to a different device using the **Restore** option, it may occur that some device functionalities are no longer available. In some cases even a device reset →  204 will not restore the original status.

In order to transmit a configuration to a different device, the **Duplicate** option should always be used.

11.10 Protection of the settings against unauthorized changes







There are two ways to protect the settings against unauthorized changes:

- Via parameter settings (software locking) →  72
- Via locking switch (hardware locking) →  74

12 Diagnostics and troubleshooting

12.1 General trouble shooting

12.1.1 General errors

Error	Possible cause	Remedial action
Device does not respond.	Supply voltage does not match the value indicated on the nameplate.	Connect the correct voltage.
	The polarity of the supply voltage is wrong.	Correct the polarity.
	The cables do not contact the terminals properly.	Ensure electrical contact between the cable and the terminal.
Values on the display invisible	Contrast setting is too weak or too strong.	<ul style="list-style-type: none"> ▪ Increase contrast by pressing  and  simultaneously. ▪ Decrease contrast by pressing  and  simultaneously.
	The plug of the display cable is not connected correctly.	Connect the plug correctly.
	Display is defective.	Replace display.
"Communication error" is indicated on the display when starting the device or connecting the display	Electromagnetic interference	Check grounding of the device.
	Broken display cable or display plug.	Exchange display.
Output current < 3.6 mA	Signal cable connection incorrect.	Check connection.
	Electronics is defective.	Replace electronics.
HART communication does not function.	Communication resistor missing or incorrectly installed.	Install the communication resistor (250 Ω) correctly →  55.
	Commubox connected incorrectly.	Connect Commubox correctly →  69.
	Commubox not switched to HART mode.	Set the selection switch of the Commubox to the HART position.
CDI communication does not work.	Wrong setting of the COM port on the computer.	Check the setting of the COM port on the computer and change it if necessary.
Device measures incorrectly.	Parametrization error	Check and adjust parameterization.

12.1.2 Parametrization errors

Parametrization errors for level measurements

Error	Possible cause	Remedial action
Measured value wrong	If measured distance (Setup → Distance) matches the real distance: Calibration error	<ul style="list-style-type: none"> Check and adjust the Empty calibration parameter (→ 140) if necessary. Check and adjust the Full calibration parameter (→ 141) if necessary. Check and adjust linearization if necessary (Linearization submenu (→ 166)).
	If measured distance (Setup → Distance) does not match the real distance: An interference echo affects the measurement.	Perform mapping (Confirm distance parameter (→ 148)).
No change of the measured value when emptying/filling the tank	An interference echo affects the measurement.	Perform mapping (Confirm distance parameter (→ 148)).
	Build-up at the probe.	Clean the probe.
	Error in the echo tracking	Deactivate echo tracking: Expert → Sensor → Echo tracking → Evaluation mode = History off .
The diagnostic message Echo lost appears after switching on the supply voltage.	Echo threshold too high.	Check the Medium group parameter (→ 140). If necessary select a more detailed setting in the Medium property parameter (→ 154).
	Level echo suppressed.	Delete mapping and record new mapping curve if required (Record map parameter (→ 150)).
Device displays a level when the tank is empty.	Incorrect probe length	Carry out probe length correction (Confirm probe length parameter (→ 182)).
	Interference echo	Carry out mapping over entire probe while the tank is empty (Confirm distance parameter (→ 148)).
Wrong slope of the level in the entire measuring range	Wrong tank type selected.	Set Tank type parameter (→ 139) correctly.

Parametrization errors for interface measurements

Error	Possible cause	Remedial action
With the setting Tank level = Fully flooded When, the measured interface level jumps to higher values during draining operations.	The total level is detected outside the upper blocking distance.	Increase blocking distance (Blocking distance parameter (→ 157)).
		Set Tank level parameter (→ 145) = Partially filled .
With the setting Tank level = Partially filled , the measured total level jumps to lower values during filling operations.	The total level runs into the upper blocking distance.	Decrease blocking distance (Blocking distance parameter (→ 157)).
Wrong slope of the measured interface level	Wrong dielectric constant (DC value).	Enter correct dielectric constant (DC value) of the upper medium (DC value parameter (→ 146)).
The measured values for the interface and the total level are identical	Echo threshold for the total level too high due to a wrong dielectric constant.	Enter correct dielectric constant (DC value) of the upper medium (DC value parameter (→ 146)).

Error	Possible cause	Remedial action
If the interface layers are thin, the total level jumps to the interface level.	The thickness of the upper medium is less than 60 mm (2.4 in).	Interface measurement is only possible if the thickness of the interface is greater than 60 mm (2.4 in).
The measured interface layer jumps.	Emulsion layer present.	Emulsion layers affect the measurement. Please contact Endress+Hauser.

12.2 Diagnostic information on local display

12.2.1 Diagnostic message

Faults detected by the self-monitoring system of the measuring device are displayed as a diagnostic message in alternation with the measured value display.

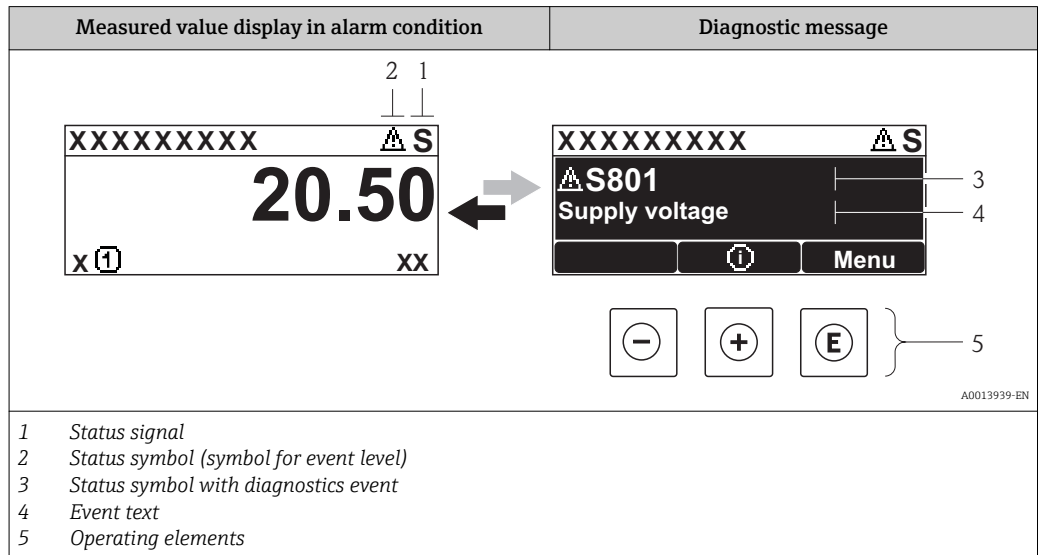

Status signals

F <small>A0013956</small>	"Failure" A device error is present. The measured value is no longer valid.
C <small>A0013959</small>	"Function check" The device is in service mode (e.g. during a simulation).
S <small>A0013958</small>	"Out of specification" The device is operated: <ul style="list-style-type: none"> ▪ Outside of its technical specifications (e.g. during startup or a cleaning) ▪ Outside of the configuration carried out by the user (e.g. level outside configured span)
M <small>A0013957</small>	"Maintenance required" Maintenance is required. The measured value is still valid.

Status symbol (symbol for event level)



 <small>A0013961</small>	"Alarm" status The measurement is interrupted. The signal outputs take on the defined alarm condition. A diagnostic message is generated.
 <small>A0013962</small>	"Warning" status The device continues to measure. A diagnostic message is generated.

Diagnostics event and event text

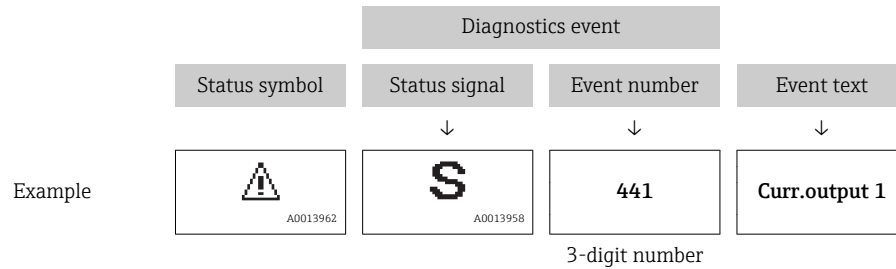

The fault can be identified using the diagnostics event. The event text helps you by providing information about the fault. In addition, the corresponding symbol is displayed before the diagnostics event.



If two or more diagnostic messages are pending simultaneously, only the message with the highest priority is shown. Additional pending diagnostic messages can be shown in **Diagnostic list** submenu (→  209).

-  Past diagnostic messages that are no longer pending are shown as follows:
- On the local display:
 - in **Event logbook** submenu (→  210)
 - in FieldCare:
 - via the "Event List /HistoROM" function.

Operating elements

Operating functions in menu, submenu	
 A0013970	Plus key Opens the message about the remedial measures.
 A0013952	Enter key Opens the operating menu.

12.2.2 Calling up remedial measures

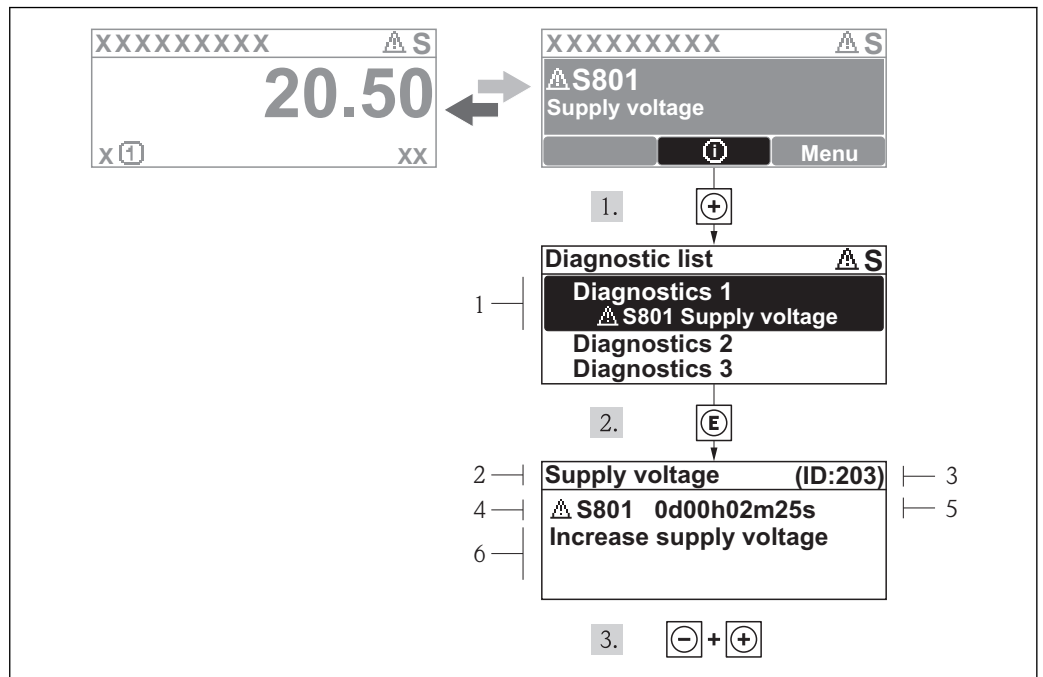

28 Message for remedial measures

- 1 Diagnostic information
- 2 Short text
- 3 Service ID
- 4 Diagnostic behavior with diagnostic code
- 5 Operation time of occurrence
- 6 Remedial measures

The user is in the diagnostic message.

1. Press '+' (i symbol).
↳ **Diagnostic list** submenu opens.
2. Select the desired diagnostic event with '+' or '-' and press 'E'.
↳ The message for the remedial measures for the selected diagnostic event opens.
3. Press '-' + '+' simultaneously.
↳ The message for the remedial measures closes.

The user is in the **Diagnostics** menu at an entry for a diagnostics event, e.g. in **Diagnostic list** submenu or in **Previous diagnostics**.

1. Press 'E'.
↳ The message for the remedial measures for the selected diagnostic event opens.
2. Press '-' + '+' simultaneously.
↳ The message for the remedial measures closes.

12.3 Diagnostic event in the operating tool

If a diagnostic event is present in the device, the status signal appears in the top left status in the operating tool along with the corresponding symbol for event level in accordance with NAMUR NE 107:

- Failure (F)
- Function check (C)
- Out of specification (S)
- Maintenance required (M)

Calling up remedial measures

1. Navigate to the **Diagnostics** menu.
 - ↳ In the **Actual diagnostics** parameter, the diagnostic event is shown with event text.
2. On the right in the display range, hover the cursor over the **Actual diagnostics** parameter.
 - ↳ A tool tip with remedial measures for the diagnostic event appears.



12.4 Diagnostic list

In the Diagnostic list submenu, up to 5 currently pending diagnostic messages can be displayed. If more than 5 messages are pending, the messages with the highest priority are shown on the display.

Navigation path

Diagnostics → Diagnostic list

Calling up and closing the remedial measures

1. Press .
- ↳ The message for the remedial measures for the selected diagnostic event opens.
2. Press  +  simultaneously.
- ↳ The message about the remedial measures closes.

12.5 List of diagnostic events

Diagnostic number	Short text	Remedy instructions	Status signal [from the factory]	Diagnostic behavior [from the factory]
Diagnostic of sensor				
003	Broken probe detected	1. Check map 2. Check sensor	F	Alarm
046	Build-up detected	Clean sensor	F	Alarm
104	HF cable	and check sealing 1. Dry HF cable connection 2. Change HF cable	F	Alarm
105	HF cable	1. Tighten HF cable connection 2. Check sensor 3. Change HF cable	F	Alarm
106	Sensor	1. Check sensor 2. Check HF cable 3. Contact service	F	Alarm
Diagnostic of electronic				
242	Software incompatible	1. Check software 2. Flash or change main electronics module	F	Alarm
252	Modules incompatible	1. Check electronic modules 2. Change I/O or main electronic module	F	Alarm
261	Electronic modules	1. Restart device 2. Check electronic modules 3. Change I/O Modul or main electronics	F	Alarm
262	Module connection	1. Check module connections 2. Change electronic modules	F	Alarm
270	Main electronic failure	Change main electronic module	F	Alarm
271	Main electronic failure	1. Restart device 2. Change main electronic module	F	Alarm
272	Main electronic failure	1. Restart device 2. Contact service	F	Alarm
273	Main electronic failure	1. Emergency operation via display 2. Change main electronics	F	Alarm
275	I/O module failure	Change I/O module	F	Alarm
276	I/O module failure	1. Restart device 2. Change I/O module	F	Alarm
282	Data storage	1. Restart device 2. Contact service	F	Alarm
283	Memory content	1. Transfer data or reset device 2. Contact service	F	Alarm
311	Electronic failure	1. Transfer data or reset device 2. Contact service	F	Alarm
311	Electronic failure	Maintenance required! 1. Do not perform reset 2. Contact service	M	Warning
Diagnostic of configuration				
410	Data transfer	1. Check connection 2. Retry data transfer	F	Alarm
411	Up-/download active	Up-/download active, please wait	C	Warning

Diagnostic number	Short text	Remedy instructions	Status signal [from the factory]	Diagnostic behavior [from the factory]
412	Processing download	Download active, please wait	C	Warning
431	Trim 1 to 2	Carry out trim	C	Warning
435	Linearization	Check linearization table	F	Alarm
437	Configuration incompatible	1. Restart device 2. Contact service	F	Alarm
438	Dataset	1. Check data set file 2. Check device configuration 3. Up- and download new configuration	M	Warning
441	Current output 1 to 2	1. Check process 2. Check current output settings	S	Warning
484	Failure mode simulation	Deactivate simulation	C	Alarm
485	Simulation measured value	Deactivate simulation	C	Warning
491	Current output 1 to 2 simulation	Deactivate simulation	C	Warning
494	Switch output simulation	Deactivate simulation switch output	C	Warning
495	Diagnostic event simulation	Deactivate simulation	C	Warning
585	Simulation distance	Deactivate simulation	C	Warning
Diagnostic of process				
801	Energy too low	Increase supply voltage	S	Warning
803	Current loop	1. Check wiring 2. Change I/O module	F	Alarm
825	Operating temperature	1. Check ambient temperature 2. Check process temperature	S	Warning
825	Operating temperature		F	Alarm
921	Change of reference	1. Check reference configuration 2. Check pressure 3. Check sensor	S	Warning
936	EMC interference	Check installation on EMC	F	Alarm
941	Echo lost	Check parameter 'DC value'	F	Alarm ¹⁾
942	In safety distance	1. Check level 2. Check safety distance 3. Reset self holding	S	Alarm ¹⁾
943	In blocking distance	Reduced accuracy Check level	S	Warning
944	Level range	Reduced accuracy Level at process connection	S	Warning
950	Advanced diagnostic 1 to 2 occurred	Maintain your diagnostic event	M	Warning ¹⁾

1) Diagnostic behavior can be changed.

12.6 Event logbook

12.6.1 Event history

A chronological overview of the event messages that have occurred is provided in the **Event list** submenu ⁵⁾.

Navigation path



Diagnostics → Event logbook → Event list

A maximum of 100 event messages can be displayed in chronological order.



The event history includes entries for:

- Diagnostic events
- Information events

In addition to the operation time of its occurrence, each event is also assigned a symbol that indicates whether the event has occurred or is ended:

- Diagnostic event
 - : Event has occurred
 - : Event has ended
- Information event
 - : Event has occurred

Calling up and closing the remedial measures

1. Press .
 - ↳ The message for the remedial measures for the selected diagnostic event opens.
2. Press  +  simultaneously.
 - ↳ The message about the remedial measures closes.

12.6.2 Filtering the event logbook

Using the **Filter options** parameter, you can define which category of event messages is displayed in the **Event list** submenu angezeigt werden.

Navigation path

Diagnostics → Event logbook → Filter options

Filter categories

- All
- Failure (F)
- Function check (C)
- Out of specification (S)
- Maintenance required (M)
- Information

12.6.3 Overview of information events

Info number	Info name
I1000	----- (Device ok)
I1089	Power on
I1090	Configuration reset
I1091	Configuration changed

5) This submenu is only available for operation via local display. In the case of operation via FieldCare, the event list can be displayed with the "Event List / HistoROM" functionality of FieldCare.

Info number	Info name
I1092	Trend data deleted
I1110	Write protection switch changed
I1137	Electronic changed
I1151	History reset
I1154	Reset terminal voltage min/max
I1155	Reset electronic temperature
I1156	Memory error trend
I1157	Memory error event list
I1184	Display connected
I1185	Display backup done
I1186	Restore via display done
I1187	Settings downloaded with display
I1188	Display data cleared
I1189	Backup compared
I1256	Display: access status changed
I1264	Safety sequence aborted
I1335	Firmware changed
I1397	Fieldbus: access status changed
I1398	CDI: access status changed
I1512	Download started
I1513	Download finished
I1514	Upload started
I1515	Upload finished
I1554	Safety sequence started
I1555	Safety sequence confirmed
I1556	Safety mode off

12.7 Firmware history

Date	Software version	Modifications	Documentation (FMP51, FMP52, FMP54, HART)		
			Operating Instructions	Description of Parameters	Technical Information
07.2010	01.00.zz	Original software	BA01001F/00/EN/05.10	GP01000F/00/EN/05.10	TI01001F/00/EN/05.10
01.2011	01.01.zz	<ul style="list-style-type: none"> ▪ SIL integrated ▪ Improvements and bugfixes ▪ additional languages 	<ul style="list-style-type: none"> ▪ BA01001F/00/EN/10.10 ▪ BA01001F/00/EN/13.11 ▪ BA01001F/00/EN/14.11 ▪ BA01001F/00/EN/15.12 	<ul style="list-style-type: none"> ▪ GP01000F/00/EN/10.10 ▪ GP01000F/00/EN/13.11 	<ul style="list-style-type: none"> ▪ TI01001F/00/EN/10.10 ▪ TI01001F/00/EN/13.11 ▪ TI01001F/00/EN/14.11 ▪ TI01001F/00/EN/15.12 ▪ TI01001F/00/EN/16.12
02.2014	01.02.zz	<ul style="list-style-type: none"> ▪ Support of SD03 additional languages ▪ HistoROM functionality enhanced ▪ "Advanced Diagnostic" function block integrated ▪ Improvements and bugfixes 	<ul style="list-style-type: none"> ▪ BA01001F/00/EN/16.13 ▪ BA01001F/00/EN/17.14 	<ul style="list-style-type: none"> ▪ GP01000F/00/EN/14.13 ▪ BA01001F/00/EN/17.14 	<ul style="list-style-type: none"> ▪ TI01001F/00/EN/17.13 ▪ TI01001F/00/EN/18.14
04.2016	01.03.zz	<ul style="list-style-type: none"> ▪ Update to HART 7 ▪ All 17 operating languages available in the device ▪ Improvements and bugfixes 	BA01001F/00/EN/18.16	GP01000F/00/EN/16.16	TI01001F/00/EN/20.16

 The firmware version can explicitly be ordered via the product structure. In this way it is possible to ensure compatibility of the firmware version with an existing or planned system integration.

13 Maintenance

The measuring device requires no special maintenance.

13.1 Exterior cleaning

When exterior-cleaning the device, always use cleaning agents that do not attack the surface of the housing and the seals.

14 Repairs

14.1 General information on repairs

14.1.1 Repair concept

The Endress+Hauser repair concept assumes that the devices have a modular design and that repairs can be done by the Endress+Hauser service or specially trained customers.

Spare parts are contained in suitable kits. They contain the related replacement instructions.

For more information on service and spare parts, contact the Service Department at Endress+Hauser.

14.1.2 Repairs to Ex-approved devices

When carrying out repairs to Ex-approved devices, please note the following:

- Repairs to Ex-approved devices may only be carried out by trained personnel or by the Endress+Hauser Service.
- Comply with the prevailing standards, national Ex-area regulations, safety instructions (XA) and certificates.
- Only use original spare parts from Endress+Hauser.
- When ordering a spare part, please note the device designation on the nameplate. Only replace parts with identical parts.
- Carry out repairs according to the instructions. On completion of repairs, carry out the specified routine test on the device.
- Only Endress+Hauser Service may convert a certified device into a different certified variant.
- Document all repair work and conversions.

14.1.3 Replacement of an electronics module

If an electronics module has been replaced, it is not necessary to perform a new basic setup as the calibration parameters are stored in the HistoROM which is located in the housing. However, after exchanging the main electronics module it may be necessary to record a new mapping (interference echo suppression).

14.1.4 Replacement of a device

After a complete device or electronic module has been replaced, the parameters can be downloaded into the instrument again in one of the following ways:

- Via the display module
Condition: The configuration of the old device has been saved in the display module
→  201.
- Via FieldCare
Condition: The configuration of the old device has been saved to the computer via FieldCare.

You can continue to measure without carrying out a new setup. Only a linearization and a tank map (interference echo suppression) have to be recorded again.

14.2 Spare parts

- A few interchangeable measuring device components are identified by a spare part nameplate. This contains information about the spare part.
- The connection compartment cover of the device contains a spare part nameplate that includes the following information:
 - A list of the most important spare parts for the measuring device, including their ordering information.
 - The URL for the *W@M Device Viewer* (www.endress.com/deviceviewer): There, all spare parts for the measuring device are listed, including the order code, and can be ordered. If available, the corresponding Installation Instructions can also be downloaded there.

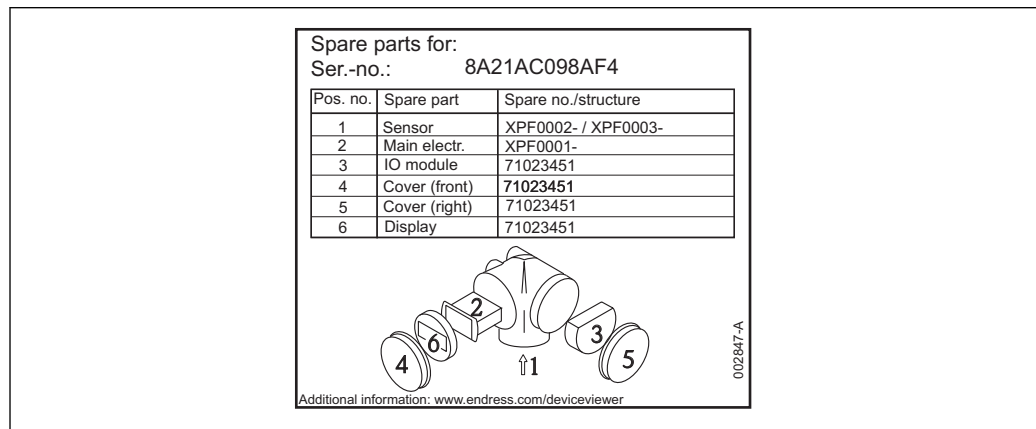

29 Example for spare part nameplate in connection compartment cover

- i** Measuring device serial number:
 - Is located on the device and spare part nameplate.
 - Can be read out via the "Serial number" parameter in the "Device information" submenu.

14.3 Return

The measuring device must be returned if it is need of repair or a factory calibration, or if the wrong measuring device has been delivered or ordered. Legal specifications require Endress+Hauser, as an ISO-certified company, to follow certain procedures when handling products that are in contact with the medium.

To ensure safe, swift and professional device returns, please refer to the procedure and conditions for returning devices provided on the Endress+Hauser website at <http://www.endress.com/support/return-material>

14.4 Disposal



Observe the following notes during disposal:

- Observe valid federal/national regulations.
- Ensure proper separation and reuse of the device components.

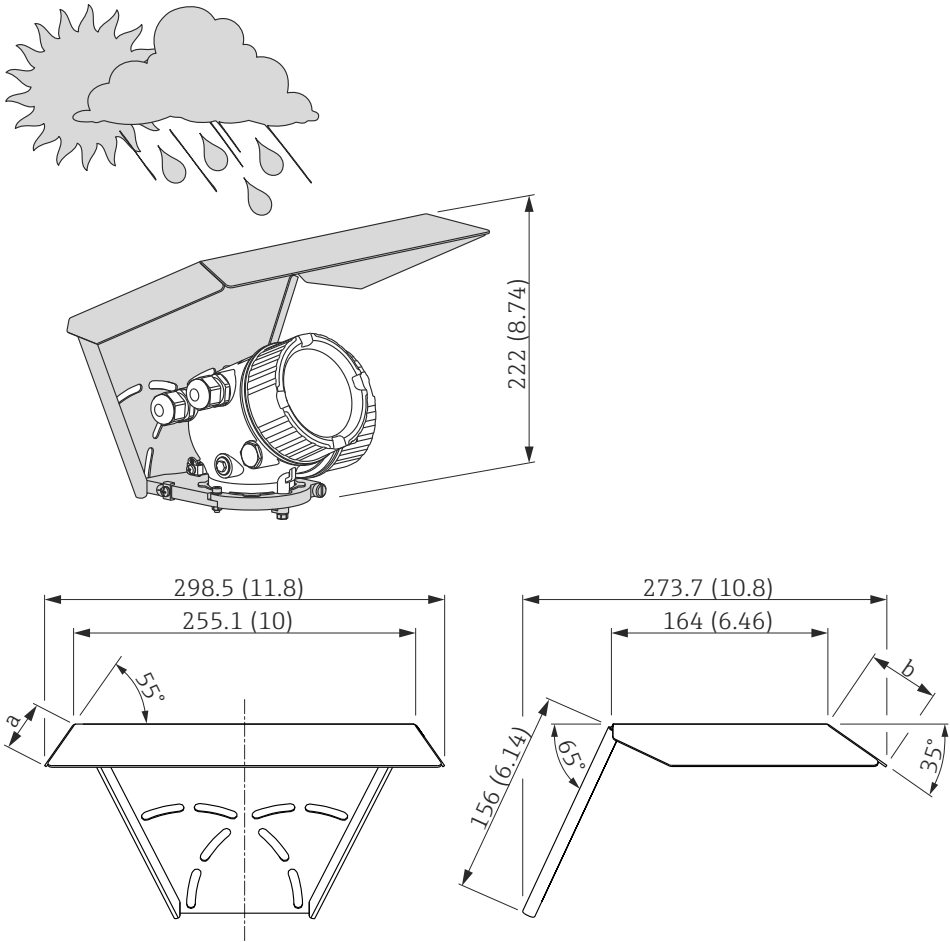

15 Accessories

15.1 Device-specific accessories

15.1.1 Weather protection cover

Accessory	Description
Weather protection cover	 <p data-bbox="1476 1059 1528 1075">A0015466</p> <p data-bbox="1476 1473 1528 1489">A0015472</p> <p data-bbox="416 1503 925 1529">☑ 30 Weather protection cover; Dimensions: mm (in)</p> <p data-bbox="416 1541 622 1568">a 37,8 mm (1,5 in)</p> <p data-bbox="416 1568 606 1594">b 54 mm (2,1 in)</p> <p data-bbox="416 1621 1492 1697">  The weather protection cover can be ordered together with the device (product structure, feature 620 "Accessory Enclosed", option PB "Weather Protection Cover"). Alternatively, it can be separately ordered as an accessory; order code 71162242. </p>

15.1.2 Mounting bracket for the electronics housing

Accessory	Description
Mounting bracket for the electronics housing	<div style="display: flex; justify-content: space-around;"> <div style="text-align: center;"> <p>A</p> </div> <div style="text-align: center;"> <p>B</p> </div> </div> <p> 31 Mounting bracket for the electronics housing; Dimensions: mm (in)</p> <p>A Wall mounting B Pipe mounting</p> <p> For the "Sensor remote" device version (see feature 060 of the product structure), the mounting bracket is part of the delivery. If required, it can also be ordered as an accessory (order code 71102216).</p> <p style="text-align: right; font-size: small;">A0014793</p>

15.1.3 Extension rod / centering HMP40

Accessory	Description	
<p>Extension rod / centering HMP40</p> <ul style="list-style-type: none"> ■ can be used for: FMP54 ■ Admissible temperature at lower nozzle edge: <ul style="list-style-type: none"> - without center washer: no limitation - with center washer: -40 to 150 °C (-40 to 302 °F) ■ Additional information: SD01002F 		
	<p>1 Nozzle height 2 Extension rod 3 Center washer</p>	
	010 Approval:	
	A	A: Non-hazardous area
	M	M: FM DIP Cl.II Div.1 Gr.E-G N.I., zone 21,22
	P	P: CSA DIP Cl.II Div.1 Gr.G + coal dust N.I.
	S	S: FM Cl.I, II, III Div.1 Gr.A-G N.I., zone 0,1,2,20,21,22
	U	U: CSA Cl.I, II, III Div.1 Gr.A-G N.I., zone 0,1,2
	1	1: ATEX II 1G
	2	2: ATEX II 1D
	020 Extension rod; nozzle height:	
	1	115mm; 150-250mm / 6-10"
	2	215mm; 250-350mm / 10-14"
	3	315mm; 350-450mm / 14-18"
	4	415mm; 450-550mm / 18-22"
	9	Special version, TSP-no. to be spec.
	030 Center washer:	
	A	Not selected
	B	DN40 / 1-1/2", inside-d. = 40-45mm, PPS
	C	DN50 / 2", inside-d. = 50-57mm, PPS
	D	DN80 / 3", inside-d. = 80-85mm, PPS
	E	DN80 / 3", inside-d. = 76-78mm, PPS
	G	DN100 / 4", inside-d. = 100-110mm, PPS
	H	DN150 / 6", inside-d. = 152-164mm, PPS
	J	DN200 / 8", inside-d. = 210-215mm, PPS
K	DN250 / 10", inside-d. = 253-269mm, PPS	
Y	Special version, TSP-no. to be spec.	

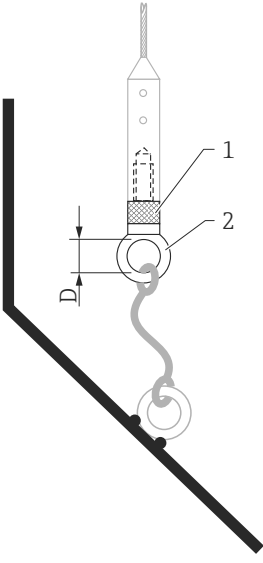

A0013597

15.1.4 Mounting kit, isolated

Accessory	Description
Mounting kit, isolated can be used for <ul style="list-style-type: none"> ■ FMP50 ■ FMP51 ■ FMP54 ■ FMP56 ■ FMP57 	<div style="text-align: center;">  </div> <p style="text-align: right; font-size: small;">A0013586</p> <p>☛ 32 Scope of supply of the mounting kit:</p> <p>1 Insulating sleeve 2 Eye-bolt</p> <p>For reliably insulated fixing of the probe. Maximum process temperature: 150 °C (300 °F)</p> <p>For rope probes 4 mm (1/6 in) or 6 mm (1/4 in) with PA>steel:</p> <ul style="list-style-type: none"> ■ Diameter D = 20 mm (0.8 in) ■ Order-No.: 52014249 <p>For rope probes 6 mm (1/4 in) or 8 mm (1/3 in) with PA>steel:</p> <ul style="list-style-type: none"> ■ Diameter D = 25 mm (1 in) ■ Order-No.: 52014250 <p>Due to the risk of electrostatic charge, the insulating sleeve is not suitable for use in hazardous areas. In these cases the fixing must be reliably grounded.</p> <p>📘 The mounting kit can also be ordered directly with the device (see the Levelflex product structure, feature 620 "Accessory Enclosed", option PG "Mounting kit, isolated, rope").</p>

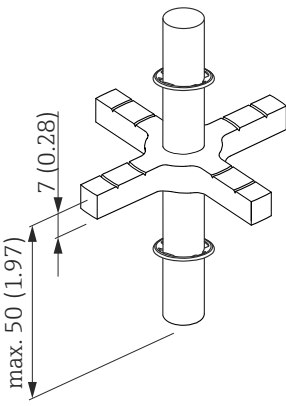
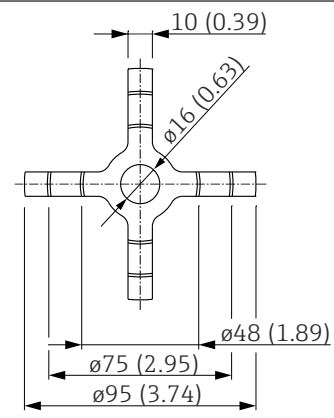
15.1.5 Centering star

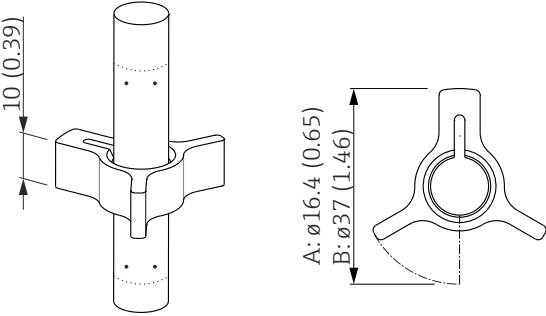
Accessory	Description
<p>Centering star PEEK ϕ 48 to 95 mm (1.89 to 3.74 inch) can be used for</p> <ul style="list-style-type: none"> ▪ FMP51 ▪ FMP54 	<div style="display: flex; justify-content: space-around; align-items: flex-start;">   </div> <p style="text-align: right; font-size: small;">A0014576</p> <p>The centering star is suitable for probes with a rod diameter of 16 mm (0.6 in) and can be used in pipes from DN40 (1½") up to DN100 (4"). Markings on the 4-leg centering star ensure a simple tailoring. Hence the centering star can be adapted to the pipe diameter. See also Operating Instructions BA00377F/00/A2.</p> <ul style="list-style-type: none"> ▪ Material of centering star: PEEK (statically dissipative) ▪ Material of retaining rings: PH15-7Mo (UNS S15700) ▪ Admissible process temperature: -60 to +200 °C (-76 to +392 °F) ▪ Order code: 71069064 <p>i If the centering star is inserted in a bypass, it must be positioned below the lower bypass outlet. This has to be accounted for when choosing the probe length. Generally, the centering star should not be mounted higher than 50 mm (1.97") from the probe end. It is recommended not to insert the PEEK centering star in the measuring range of the rod probe.</p> <p>i The PEEK centering star can also be ordered directly with the device (see the Levelflex product structure, feature 610 "Accessory mounted", option OD). In this case it is not fastened by the retaining rings. Instead it is fixed to the end of the probe rod by a hexagonal headed bolt (A4-70) and a Nord-Lock washer (1.4547).</p>

Accessory	Description
<p>Centering star PFA</p> <ul style="list-style-type: none"> ■ ϕ 16.4 mm (0.65 in) ■ ϕ 37 mm (1.46 in) <p>can be used for</p> <ul style="list-style-type: none"> ■ FMP51 ■ FMP52 ■ FMP54 	<div style="display: flex; justify-content: space-around; align-items: center;">  </div> <p style="text-align: right; font-size: small;">A0014577</p> <p>A For 8 mm (0.3 in) probes B: For 12 mm (0.47 in) and 16 mm (0.63 in) probes</p> <p>The centering star is suitable for probes with a rod diameter of 8 mm (0.3 in), 12 mm (0.47 in) and 16 mm (0.63 in) (also coated rod probes) and can be used in pipes from DN40 (1½") up to DN50 (2"). See also Operating Instructions BA00378F/00/A2.</p> <ul style="list-style-type: none"> ■ Material: PFA ■ Admissible process temperature: -200 to +200 °C (-382 to +392 °F) ■ Order code <ul style="list-style-type: none"> - Probe 8 mm (0.3 in): 71162453 - Probe 12 mm (0.47 in): 71157270 - Probe 16 mm (0.63 in): 71069065 <p> The PFA centering star can also be ordered directly with the device (see the Levelflex product structure, feature 610 "Accessory mounted", option OE).</p>

15.1.6 Remote display FHX50

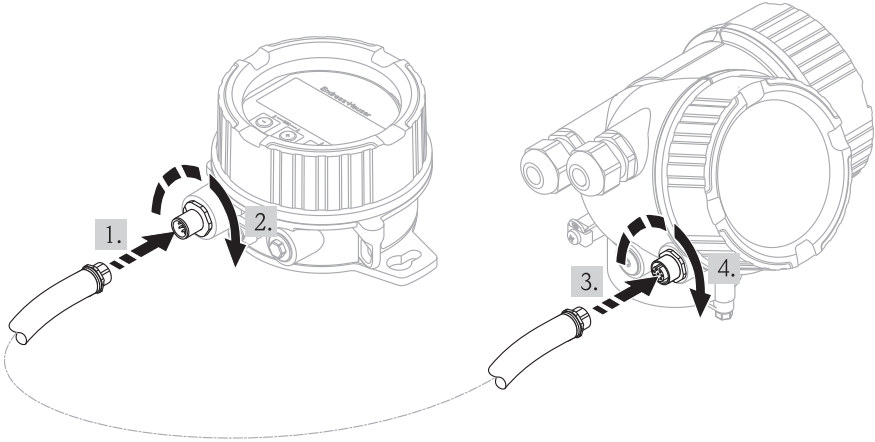
Accessory	Description
Remote display FHX50	<div style="text-align: center;">  </div> <p style="text-align: right; font-size: small;">A0019128</p> <ul style="list-style-type: none"> ▪ Material: <ul style="list-style-type: none"> - Plastics PBT - CF3M (similar to 316L/1.4404) - Aluminum (in preparation) ▪ Ingress protection: IP68 / NEMA 6P and IP66 / NEMA 4x ▪ Suitable for the display modules: <ul style="list-style-type: none"> - SD02 (push buttons) - SD03 (touch control) ▪ Connection cable: <ul style="list-style-type: none"> - Cable with M12 plug; supplied with the FHX50; up to 30 m (98 ft) - Customer supplied standard cable; up to 60 m (196 ft) ▪ Ambient temperature: -40 to 80 °C (-40 to 176 °F) <p>i ▪ If the remote display is to be used, the device must be ordered in the version "Prepared for display FHX50" (feature 030, option L or M). For the FHX50, on the other hand, the option A: "Prepared for display FHX50" has to be selected in feature 050: "Option Measurement Device".</p> <p>▪ If a device has not been ordered in the version "Prepared for display FHX50", but is nevertheless to be equipped with an FHX50, it is essential to select the option B: "Not prepared for display FHX50" in feature 050: "Option Measurement Device" of the FHX50. In this case, a retrofit kit, needed to prepare the device for the remote display, is supplied together with the FHX50.</p> <p>i For transmitters with approval, application of the FHX50 may be restricted. A device may only be retrofitted with the FHX50 if option L or M ("Prepared for FHX50") is quoted under <i>Basic specifications</i>, position 4 "Display, operation" in the associated Safety Instructions (XA). In addition to this, observe the Safety Instructions (XA) of the FHX50.</p> <p>i Do not retrofit transmitters with:</p> <ul style="list-style-type: none"> ▪ approval for use in areas with combustible dusts (Dust-Ex approval) ▪ type of protection Ex nA <p>i For details refer to the document SD01007F.</p>

15.1.7 Overvoltage protection

Accessory	Description
Overvoltage protection for 2-wire-devices OVP10 (1 channel) OVP20 (2 channel)	<div data-bbox="327 324 715 660" data-label="Image"> </div> <div data-bbox="1380 667 1437 683" data-label="Text"> <p>A0021734</p> </div> <p data-bbox="327 712 470 734">Technical data</p> <ul data-bbox="327 739 917 896" style="list-style-type: none"> ▪ Resistance per channel: $2 * 0.5 \Omega_{max}$ ▪ Threshold DC voltage: 400 to 700 V ▪ Threshold impulse voltage: < 800 V ▪ Capacitance at 1 MHz: < 1.5 pF ▪ Nominal arrest impulse voltage (8/20 μs): 10 kA ▪ Suited for wire cross-sections: 0.2 to 2.5 mm² (24 to 14 AWG) <p data-bbox="327 907 582 929">i Ordering with device</p> <p data-bbox="375 934 1388 1008">The overvoltage protection module is preferably ordered with the device. See product structure, feature 610 "Accessory mounted", option NA "Overvoltage protection". Separate ordering of the module is only necessary if a device is to be retrofitted with the overvoltage protection.</p> <p data-bbox="327 1019 630 1041">i Order code for retrofitting</p> <ul data-bbox="375 1046 901 1153" style="list-style-type: none"> ▪ For 1-channel devices (feature 020, option A) OVP10: 71128617 ▪ For 2-channel devices (feature 020, option B, C, E or G) OVP20 : 71128619 <p data-bbox="375 1164 638 1187">Housing lid for retrofitting</p> <p data-bbox="375 1191 1420 1243">In order to keep the necessary safety distances, the housing lid needs to be replaced if the device is retrofitted with the overvoltage protection. Depending on the housing type, the order code of the suitable lid is as follows:</p> <ul data-bbox="375 1247 678 1321" style="list-style-type: none"> ▪ GT18 housing: Lid 71185516 ▪ GT19 housing: Lid 71185518 ▪ GT20 housing: Lid 71185516 <p data-bbox="327 1332 646 1355">i Restrictions for retrofitting</p> <p data-bbox="375 1359 1428 1433">Depending on the approval of the transmitter the usage of the OVP module may be restricted. A device may only be retrofitted with an OVP module if the option NA (overvoltage protection) is quoted under <i>Optional Specifications</i> in the Safety Instructions (XA) pertaining to the device.</p> <p data-bbox="327 1444 662 1467">i For details refer to SD01090F.</p>

15.2 Communication-specific accessories

Accessory	Description
Commubox FXA195 HART	For intrinsically safe HART communication with FieldCare via the USB interface.  For details refer to Technical Information TI00404F

Accessory	Description
Commubox FXA291	Connects Endress+Hauser field devices with CDI interface (= Endress+Hauser Common Data Interface) to the USB interface of a computer. Order code: 51516983  For details refer to Technical Information TI00405C

Accessory	Description
HART Loop Converter HMX50	Evaluates the dynamic HART variables and converts them to analog current signals or limit values. Order code: 71063562  For details refer to Technical Information TI00429F and Operating Instructions BA00371F

Accessory	Description
WirelessHART Adapter SWA70	Connects field devices to a WirelessHART network. The WirelessHART adapter can be mounted directly at a HART device and is easily integrated into an existing HART network. It ensures safe data transmission and can be operated in parallel with other wireless networks.  For details refer to Operating Instructions BA00061S

Accessory	Description
Fieldgate FXA320	Gateway for remote monitoring of connected 4-20mA measuring devices via web browser.  For details refer to Technical Information TI00025S and Operating Instructions BA00053S

Accessory	Description
Fieldgate FXA520	Gateway for remote diagnosis and parametrization of connected HART measuring devices via web browser.  For details refer to Technical Information TI00025S and Operating Instructions BA00051S



Accessory	Description
Field Xpert SFX350	Field Xpert SFX350 is a mobile computer for commissioning and maintenance. It enables efficient device configuration and diagnostics for HART and FOUNDATION fieldbus devices in the non-Ex area .  For details, see Operating Instructions BA01202S

Accessory	Description
Field Xpert SFX370	<p>Field Xpert SFX370 is a mobile computer for commissioning and maintenance. It enables efficient device configuration and diagnostics for HART and FOUNDATION fieldbus devices in the non-Ex area and the Ex area.</p> <p> For details, see Operating Instructions BA01202S</p>

15.3 Service-specific accessories

Accessory	Description
FieldCare / DeviceCare	<p>Endress+Hauser's FDT-based Plant Asset Management tool. Helps to configure and maintain all field devices of your plant. By supplying status information it also supports the diagnosis of the devices.</p> <p> For details refer to Operating Instructions BA00027S and BA00059S.</p>





















15.4 System components

























Accessory	Description
Graphic Data Manager Memograph M	<p>The graphic data manager Memograph M provides information on all the relevant process variables. Measured values are recorded correctly, limit values are monitored and measuring points analyzed. The data are stored in the 256 MB internal memory and also on an SD card or USB stick.</p> <p> For details refer to Technical Information TI00133R and Operating Instructions BA00247R</p>
RN221N	<p>Active barrier with power supply for safe separation of 4 to 20 mA current circuits. Provides bi-directional HART transmission.</p> <p> For details refer to Technical Information TI00073R and Operating Instructions BA00202R</p>
RNS221	<p>Transmitter supply for 2-wire sensors or transmitters exclusively for non-Ex areas. Provides bi-directional communication using the HART communication sockets.</p> <p> For details refer to Technical Information TI00081R and Operating Instructions KA00110R</p>

16 Operating menu

16.1 Overview of the operating menu (display module)

Navigation  Operating menu

Language	→  194
Setup	→  138
Device tag	→  138
Operating mode	→  138
Distance unit	→  138
Tank type	→  139
Tube diameter	→  139
Tank level	→  145
Distance to upper connection	→  146
DC value	→  146
Medium group	→  140
Empty calibration	→  140
Full calibration	→  141
Level	→  142
Interface	→  147
Distance	→  143
Interface distance	→  148
Signal quality	→  144
▶ Mapping	→  151
Confirm distance	→  151
Mapping end point	→  151























Record map	→  151
Distance	→  151
▶ Advanced setup	→  152
Locking status	→  152
Access status display	→  153
Enter access code	→  153
▶ Level	→  154
Medium type	→  154
Medium property	→  154
Process property	→  155
Advanced process conditions	→  156
Level unit	→  157
Blocking distance	→  157
Level correction	→  158
▶ Interface	→  159
Process property	→  159
DC value lower medium	→  159
Level unit	→  160
Blocking distance	→  160
Level correction	→  161
▶ Automatic DC calculation	→  164
Manual thickness upper layer	→  164
DC value	→  164
Use calculated DC value	→  164

▶ Linearization	→ 166
Linearization type	→ 168
Unit after linearization	→ 169
Free text	→ 170
Maximum value	→ 171
Diameter	→ 171
Intermediate height	→ 172
Table mode	→ 172
▶ Edit table	
Level	→ 174
Customer value	→ 174
Activate table	→ 174
▶ Safety settings	→ 176
Output echo lost	→ 176
Value echo lost	→ 176
Ramp at echo lost	→ 177
Blocking distance	→ 157
▶ SIL/WHG confirmation	→ 179
▶ Deactivate SIL/WHG	→ 180
Reset write protection	→ 180
Code incorrect	→ 180

▶ Probe settings	→ 181
Probe grounded	→ 181
▶ Probe length correction	→ 183
Confirm probe length	→ 183
Present probe length	→ 183
▶ Current output 1 to 2	→ 184
Assign current output	→ 184
Current span	→ 185
Fixed current	→ 186
Damping output	→ 186
Failure mode	→ 186
Failure current	→ 187
Output current 1 to 2	→ 187
▶ Switch output	→ 188
Switch output function	→ 188
Assign status	→ 188
Assign limit	→ 189
Assign diagnostic behavior	→ 189
Switch-on value	→ 190
Switch-on delay	→ 191
Switch-off value	→ 191
Switch-off delay	→ 192
Failure mode	→ 192
Switch status	→ 192
Invert output signal	→ 192

► Display	→ 194
Language	→ 194
Format display	→ 194
Value 1 to 4 display	→ 196
Decimal places 1 to 4	→ 196
Display interval	→ 197
Display damping	→ 197
Header	→ 197
Header text	→ 198
Separator	→ 198
Number format	→ 198
Decimal places menu	→ 199
Backlight	→ 199
Contrast display	→ 200
► Configuration backup display	→ 201
Operating time	→ 201
Last backup	→ 201























Configuration management	→ 201
Comparison result	→ 202
▶ Administration	→ 204
▶ Define access code	→ 206
Define access code	→ 206
Confirm access code	→ 206
Device reset	→ 204
🔍 Diagnostics	→ 207
Actual diagnostics	→ 207
Previous diagnostics	→ 207
Operating time from restart	→ 208
Operating time	→ 201
▶ Diagnostic list	→ 209
Diagnostics 1 to 5	→ 209
▶ Event logbook	→ 210
Filter options	→ 210
▶ Event list	→ 210
▶ Device information	→ 211
Device tag	→ 211
Serial number	→ 211
Firmware version	→ 211
Device name	→ 211
Order code	→ 212
Extended order code 1 to 3	→ 212
Device revision	→ 212

























Device ID	→  212
Device type	→  213
Manufacturer ID	→  213
▶ Measured values	→  214
Distance	→  143
Level linearized	→  170
Interface distance	→  148
Interface linearized	→  171
Thickness upper layer	→  216
Output current 1 to 2	→  187
Measured current 1	→  216
Terminal voltage 1	→  217
▶ Data logging	→  218
Assign channel 1 to 4	→  218
Logging interval	→  219
Clear logging data	→  219
▶ Display channel 1 to 4	→  220
▶ Simulation	→  222
Assign measurement variable	→  223
Process variable value	→  223
Current output 1 to 2 simulation	→  224
Value current output 1 to 2	→  224
Switch output simulation	→  224

Switch status	→ 225
Device alarm simulation	→ 225
► Device check	→ 226
Start device check	→ 226
Result device check	→ 226
Last check time	→ 226
Level signal	→ 227
Launch signal	→ 227
Interface signal	→ 227

16.2 Overview of the operating menu (operating tool)



























Navigation  Operating menu

























Setup	→  138
Device tag	→  138
Operating mode	→  138
Distance unit	→  138
Tank type	→  139
Tube diameter	→  139
Medium group	→  140
Empty calibration	→  140
Full calibration	→  141
Level	→  142
Distance	→  143
Signal quality	→  144
Tank level	→  145
Distance to upper connection	→  146
DC value	→  146
Interface	→  147
Interface distance	→  148
Confirm distance	→  148
Present mapping	→  149
Mapping end point	→  150
Record map	→  150
► Advanced setup	→  152
Locking status	→  152

















Access status tooling	→  152
Enter access code	→  153
► Level	→  154
Medium type	→  154
Medium property	→  154
Process property	→  155
Advanced process conditions	→  156
Level unit	→  157
Blocking distance	→  157
Level correction	→  158
► Interface	→  159
Process property	→  159
DC value lower medium	→  159
Level unit	→  160
Blocking distance	→  160
Level correction	→  161
Manual thickness upper layer	→  161
Measured thickness upper layer	→  162
DC value	→  162
Calculated DC value	→  162
Use calculated DC value	→  163
► Linearization	→  166
Linearization type	→  168
Unit after linearization	→  169
Free text	→  170

Level linearized	→ 170
Interface linearized	→ 171
Maximum value	→ 171
Diameter	→ 171
Intermediate height	→ 172
Table mode	→ 172
Table number	→ 173
Level	→ 174
Level	→ 174
Customer value	→ 174
Activate table	→ 174
► Safety settings	→ 176
Output echo lost	→ 176
Value echo lost	→ 176
Ramp at echo lost	→ 177
Blocking distance	→ 157
► SIL/WHG confirmation	→ 179
► Deactivate SIL/WHG	→ 180
Reset write protection	→ 180
Code incorrect	→ 180
► Probe settings	→ 181
Probe grounded	→ 181
Present probe length	→ 181
Confirm probe length	→ 182





▶ Current output 1 to 2	→ 184
Assign current output	→ 184
Current span	→ 185
Fixed current	→ 186
Damping output	→ 186
Failure mode	→ 186
Failure current	→ 187
Output current 1 to 2	→ 187
▶ Switch output	→ 188
Switch output function	→ 188
Assign status	→ 188
Assign limit	→ 189
Assign diagnostic behavior	→ 189
Switch-on value	→ 190
Switch-on delay	→ 191
Switch-off value	→ 191
Switch-off delay	→ 192
Failure mode	→ 192
Switch status	→ 192
Invert output signal	→ 192
▶ Display	→ 194
Language	→ 194
Format display	→ 194
Value 1 to 4 display	→ 196
Decimal places 1 to 4	→ 196

Display interval	→  197
Display damping	→  197
Header	→  197
Header text	→  198
Separator	→  198
Number format	→  198
Decimal places menu	→  199
Backlight	→  199
Contrast display	→  200
► Configuration backup display	→  201
Operating time	→  201
Last backup	→  201
Configuration management	→  201
Backup state	→  202
Comparison result	→  202
► Administration	→  204
Define access code	→  206
Device reset	→  204
 Diagnostics	→  207
Actual diagnostics	→  207
Timestamp	→  207
Previous diagnostics	→  207
Timestamp	→  208
Operating time from restart	→  208
Operating time	→  201

► Diagnostic list	→  209
Diagnostics 1 to 5	→  209
Timestamp 1 to 5	→  209
► Device information	→  211
Device tag	→  211
Serial number	→  211
Firmware version	→  211
Device name	→  211
Order code	→  212
Extended order code 1 to 3	→  212
Device revision	→  212
Device ID	→  212
Device type	→  213
Manufacturer ID	→  213
► Measured values	→  214
Distance	→  143
Level linearized	→  170
Interface distance	→  148
Interface linearized	→  171
Thickness upper layer	→  216
Output current 1 to 2	→  187
Measured current 1	→  216
Terminal voltage 1	→  217
► Data logging	→  218
Assign channel 1 to 4	→  218



Logging interval	→  219
Clear logging data	→  219
► Simulation	→  222
Assign measurement variable	→  223
Process variable value	→  223
Current output 1 to 2 simulation	→  224
Value current output 1 to 2	→  224
Switch output simulation	→  224
Switch status	→  225
Device alarm simulation	→  225
► Device check	→  226
Start device check	→  226
Result device check	→  226
Last check time	→  226
Level signal	→  227
Launch signal	→  227
Interface signal	→  227

16.3 "Setup" menu



- 
 -  : Marks the navigation path to the parameter via the display and operating module.
 -  : Marks the navigation path to the parameter via an operating tool (e.g. FieldCare).
 -  : Marks parameters which can be locked via the software locking →  72.

Navigation   Setup

Device tag

Navigation	  Setup → Device tag
Description	Enter a unique name for the measuring point to identify the device quickly within the plant.
Factory setting	FMP5x

Operating mode

Navigation	  Setup → Operating mode
Prerequisite	The device has the "interface measurement" application package (available for FMP51, FMP52, FMP54) ⁶⁾ . FMP55 always contains this package.
Description	Select operating mode.
Selection	<ul style="list-style-type: none"> ▪ Level ▪ Interface with capacitance * ▪ Interface *
Factory setting	<ul style="list-style-type: none"> ▪ FMP51/FMP52/FMP54: Level ▪ FMP55: Interface with capacitance
Additional information	The Interface with capacitance option is only available for FMP55.

Distance unit

Navigation	  Setup → Distance unit
Description	Select distance unit.

⁶⁾ Product structure: Feature 540 "Application Package", Option EB "Interface measurement"
^{*} Visibility depends on order options or device settings

Selection	<i>SI units</i> <ul style="list-style-type: none"> ■ mm ■ m 	<i>US units</i> <ul style="list-style-type: none"> ■ ft ■ in
Factory setting	m	

Tank type

Navigation	Setup → Tank type
Prerequisite	Medium type (→ 154) = Liquid
Description	Select tank type.
Selection	<ul style="list-style-type: none"> ■ Metallic ■ Bypass / pipe ■ Non metallic ■ Mounted outside ■ Coaxial
Factory setting	Depending on the probe
Additional information	<ul style="list-style-type: none"> ■ Depending on the probe some of the options mentioned above may not be available or there may be additional options. ■ For coax probes, the default setting is Tank type = Coaxial and can not be changed. ■ For probes with metallic center washer, Tank type = Bypass / pipe is preset and can not be changed.

Tube diameter

Navigation	Setup → Tube diameter
Prerequisite	<ul style="list-style-type: none"> ■ Tank type (→ 139) = Bypass / pipe ■ The probe is coated.
Description	Specify diameter of bypass or stilling well.
User entry	0 to 9.999 m
Factory setting	0.0384 m

Medium group

Navigation	Setup → Medium group
Prerequisite	<ul style="list-style-type: none"> ▪ For FMP51/FMP52/FMP54/FMP55: Operating mode (→ 138) = Level ▪ Medium type (→ 154) = Liquid
Description	Select medium group.
Selection	<ul style="list-style-type: none"> ▪ Others ▪ Water based (DC >= 4)
Factory setting	Others
Additional information	<p>This parameter roughly specifies the dielectric constant (DC) of the medium. For a more detailed definition of the DC use the Medium property parameter (→ 154).</p> <p>The Medium group parameter presets the Medium property parameter (→ 154) as follows:</p>

Medium group	Medium property (→ 154)
Others	Unknown
Water based (DC >= 4)	DC 4 ... 7

- The **Medium property** parameter can be changed at a later point of time. However, when doing so, the **Medium group** parameter retains its value. Only the **Medium property** parameter is relevant for the signal evaluation.
- The measuring range may be reduced for small dielectric constants. For details refer to the Technical Information (TI) of the respective device.

Empty calibration

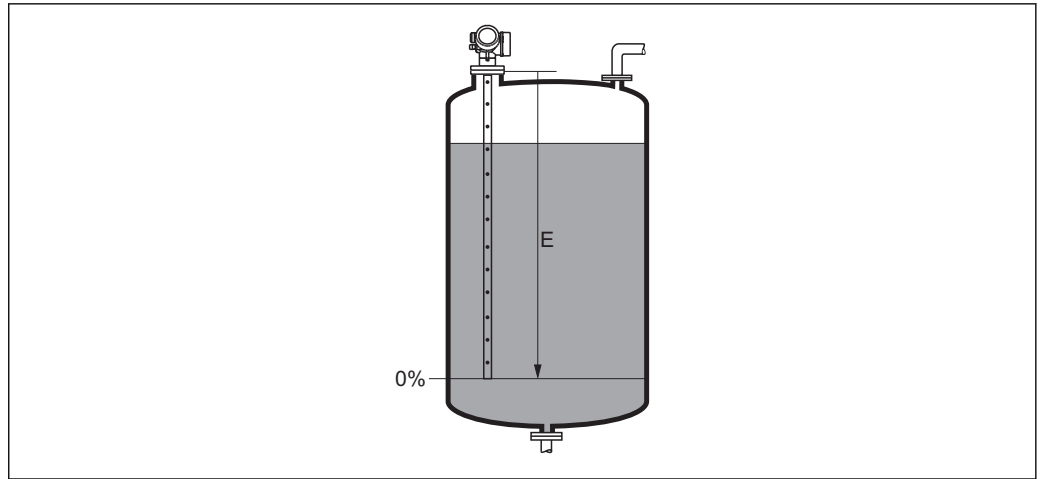

Navigation	Setup → Empty calibr.
Description	Specify the distance E between the process connection and the minimum level (0%). This defines the starting point of the measuring range.
User entry	Depending on the probe
Factory setting	Depending on the probe

Additional information

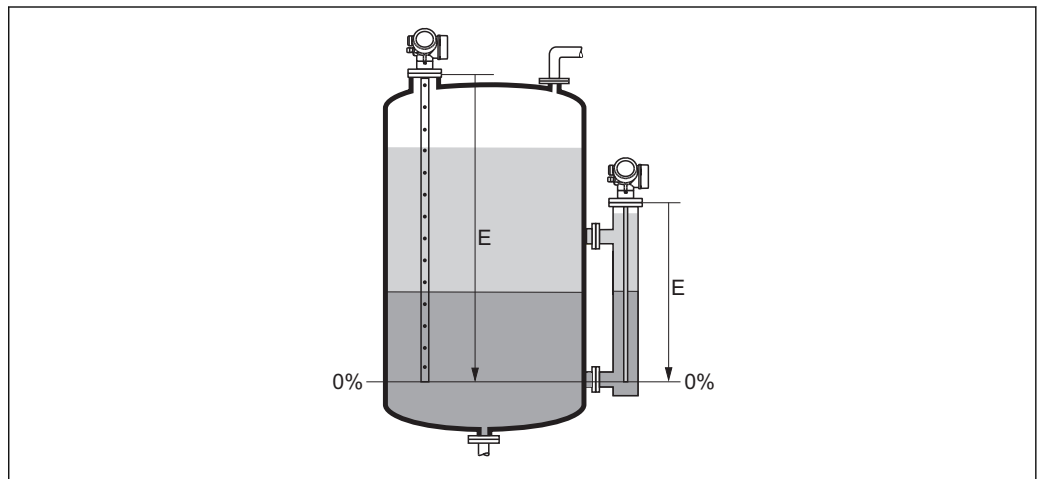

A0013176

33 Empty calibration (E) for level measurements in liquids



A0013177

34 Empty calibration (E) for interface measurements

i In the case of interface measurements the **Empty calibration** parameter is valid for both, the total and the interface level.

Full calibration



Navigation

 Setup → Full calibr.

Description

Specify the distance F between the minimum level (0%) and the maximum level (100%).

User entry

Depending on the probe

Factory setting

Depending on the probe

Additional information

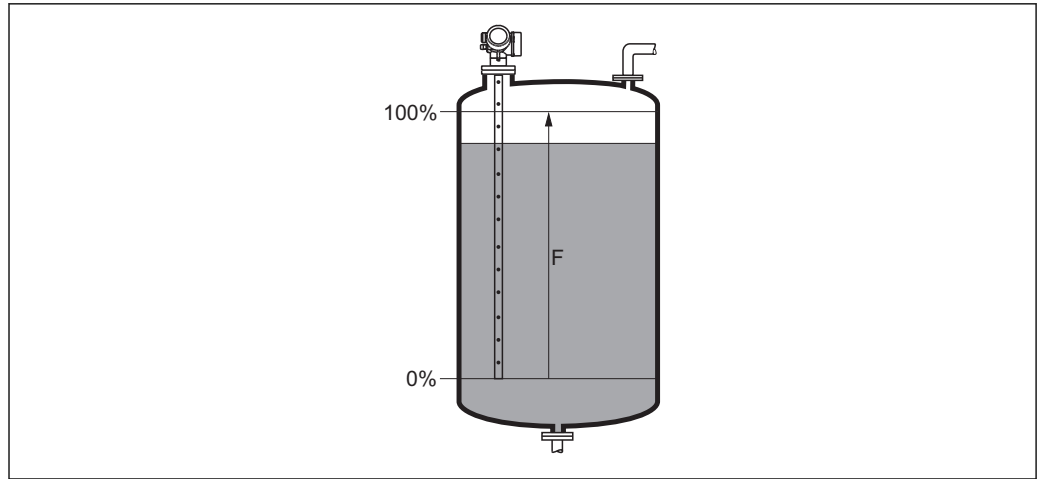

35 Full calibration (F) for level measurements in liquids

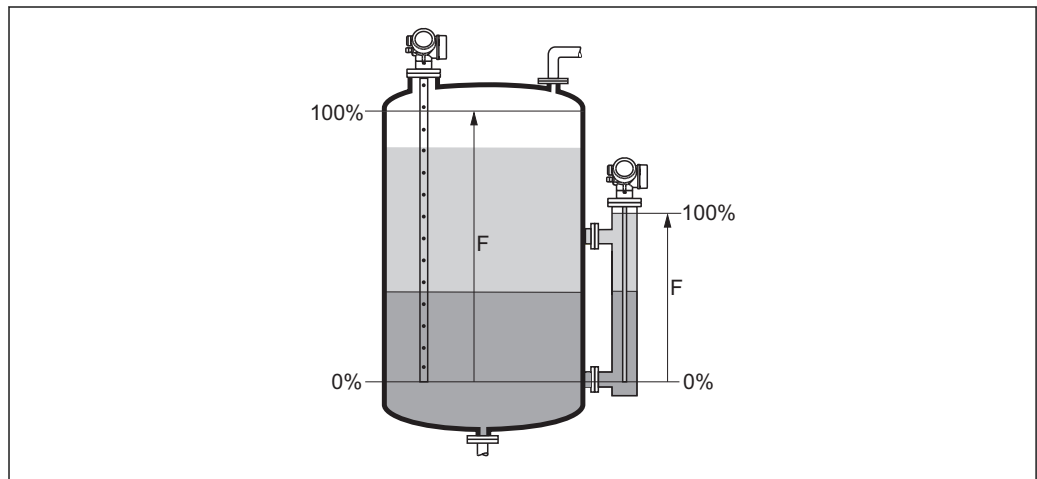

36 Full calibration (F) for interface measurements

i In the case of interface measurements the **Full calibration** parameter is valid for both, the total and the interface level.

Level

Navigation

☰ ☰ Setup → Level

Description

Displays measured level L_L (before linearization).

Additional information

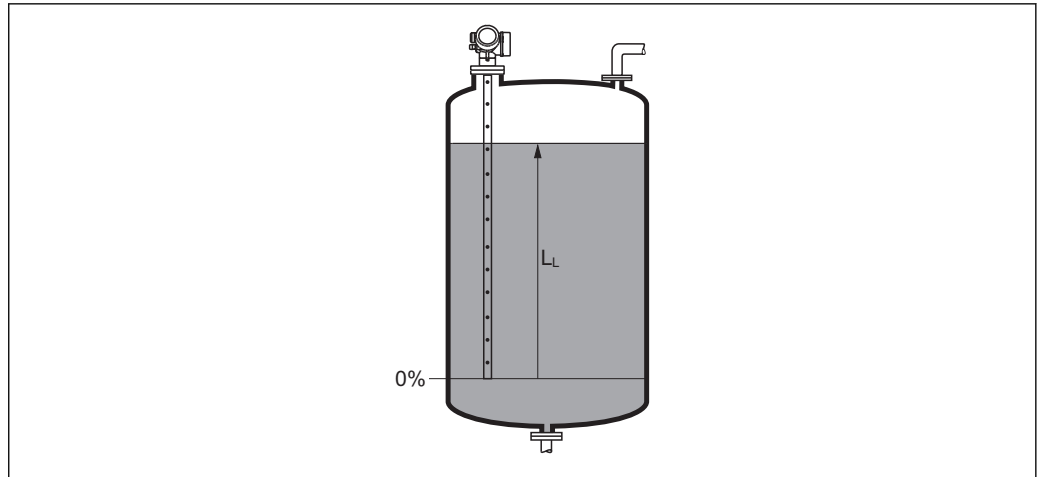

A0013194

37 Level in case of liquid measurements

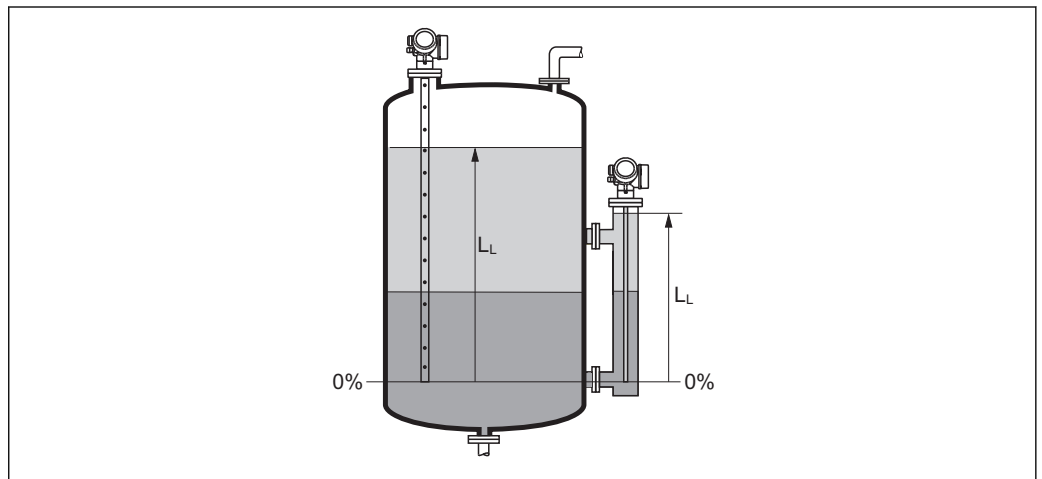

A0013195



38 Level in case of interface measurements

- i

 - The unit is defined in the **Level unit** parameter (→ 157).
 - In case of interface measurements, this parameter always refers to the total level.

Distance

Navigation

  Setup → Distance

Description

Displays the measured distance D_L between the reference point (lower edge of the flange or threaded connection) and the level.

Additional information

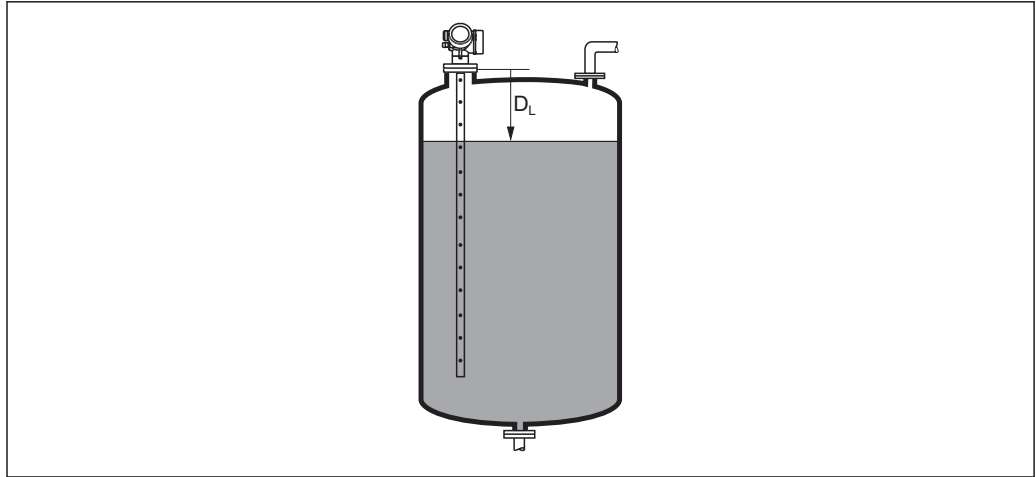

A0013196

 39 Distance for liquid measurements

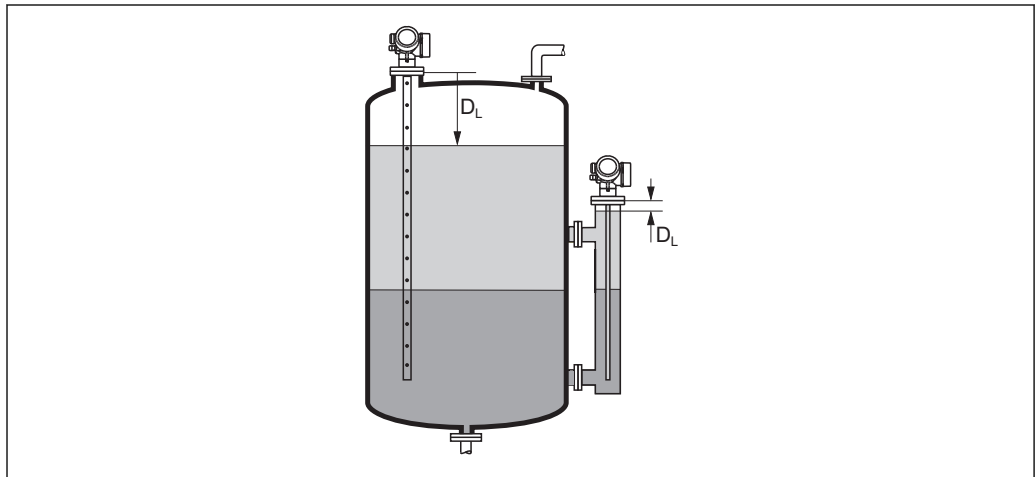



A0013199

 40 Distance for interface measurements

 The unit is defined in the **Distance unit** parameter (→  138).

Signal quality

Navigation

  Setup → Signal quality

Description

Displays the signal quality of the evaluated echo.

Additional information

Meaning of the display options

- **Strong**
The evaluated echo exceeds the threshold by at least 10 mV.
- **Medium**
The evaluated echo exceeds the threshold by at least 5 mV.
- **Weak**
The evaluated echo exceeds the threshold by less than 5 mV.
- **No signal**
The device does not find a usable echo.

The signal quality indicated in this parameter always refers to the currently evaluated echo: either the level/interface echo⁷⁾ or the end-of-probe echo. To differentiate between these two, the quality of the end-of-probe echo is always displayed in brackets.

i In case of a lost echo (**Signal quality = No signal**) the device generates the following error message:

- F941, for **Output echo lost** (→ **176**) = **Alarm**.
- S941, if another option has been selected in **Output echo lost** (→ **176**).

Tank level 🔒

Navigation 📁📁 Setup → Tank level

Prerequisite **Operating mode** (→ **138**) = **Interface**

Description Specify whether the tank or bypass is completely flooded or not.

Selection

- Partially filled
- Fully flooded

Factory setting Partially filled

Additional information **Meaning of the options**

- **Partially filled**
The device searches for 2 echo signals, one for the interface and one for the total level.
- **Fully flooded**
The device searches for the interface level only. With this setting it is essential that the upper level signal always is within the upper blocking distance (UB) in order to avoid that it is evaluated by mistake.

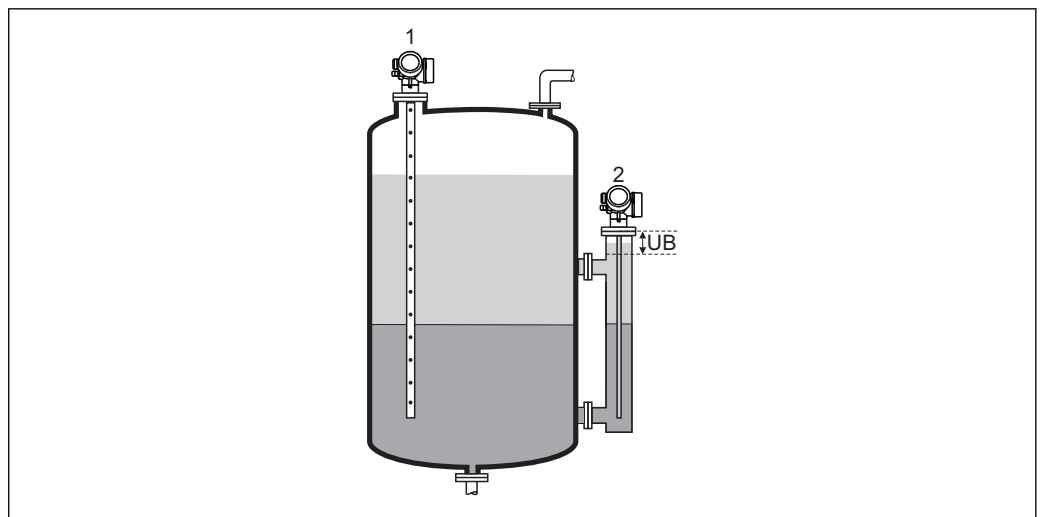

A0013173

- 1 Partially filled
2 Fully flooded
UB Upper blocking distance

7) Of these two echos the one with the lower quality is indicated.

Distance to upper connection

Navigation	Setup → Dist. up.connect
Prerequisite	The device has the "Interface measurement" application package ⁸⁾ .
Description	Specify distance D_U to upper connection.
User entry	0 to 200 m
Factory setting	<ul style="list-style-type: none"> ■ For Tank level (→ 145) = Partially filled: 0 mm (0 in) ■ For Tank level (→ 145) = Fully flooded: 250 mm (9.8 in)

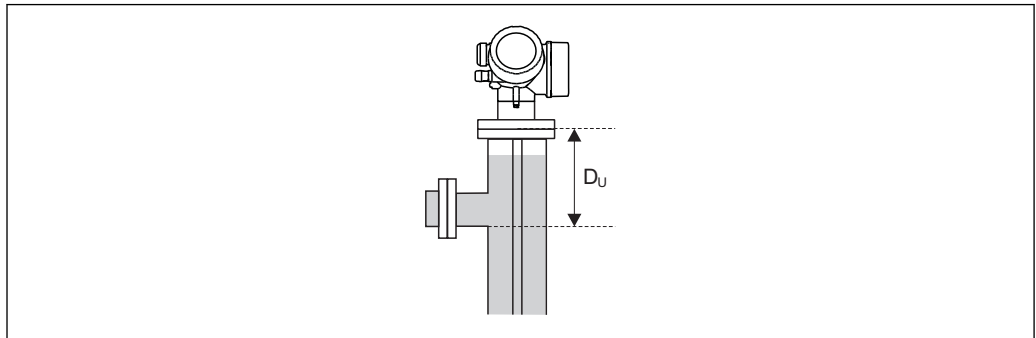
Additional information

A0013174

Dependence on the "Tank level" parameter

- **Tank level (→ 145) = Partially filled:**
In this case the **Distance to upper connection** parameter does not influence the measurement. Thus, the default setting needs not to be changed.
- **Tank level (→ 145) = Fully flooded:**
In this case enter the distance D_U between the reference point and the lower edge of the upper connection.

DC value

Navigation	Setup → DC value
Prerequisite	The device has the "interface measurement" application package ⁹⁾ .
Description	Specify relative dielectric constant ϵ_r of the upper medium (DC_1).
User entry	1.0 to 100
Factory setting	2.0

8) Product structure: Feature 540 "Application Package", Option EB "Interface measurement"

9) Product structure: Feature 540 "Application Package", Option EB "Interface measurement"

Additional information

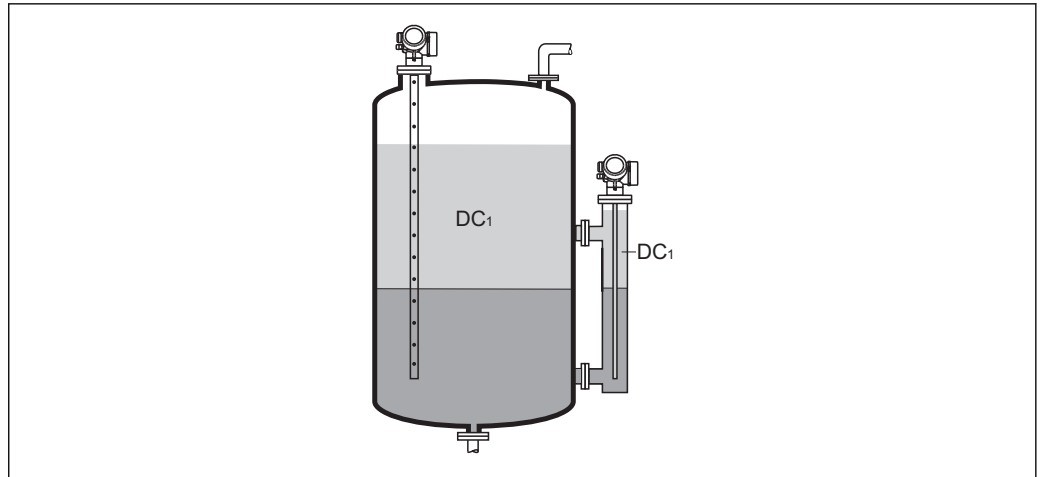

A0013181

DC_1 Relative dielectric constant of the upper medium.



For dielectric constants (DC values) of many media commonly used in various industries refer to:

- the Endress+Hauser DC manual (CP01076F)
- the Endress+Hauser "DC Values App" (available for Android and iOS)

Interface

Navigation

Setup → Interface

Prerequisite

Operating mode (→ 138) = **Interface** or **Interface with capacitance**

Description

Displays the measured interface level L_I (before linearization).

Additional information

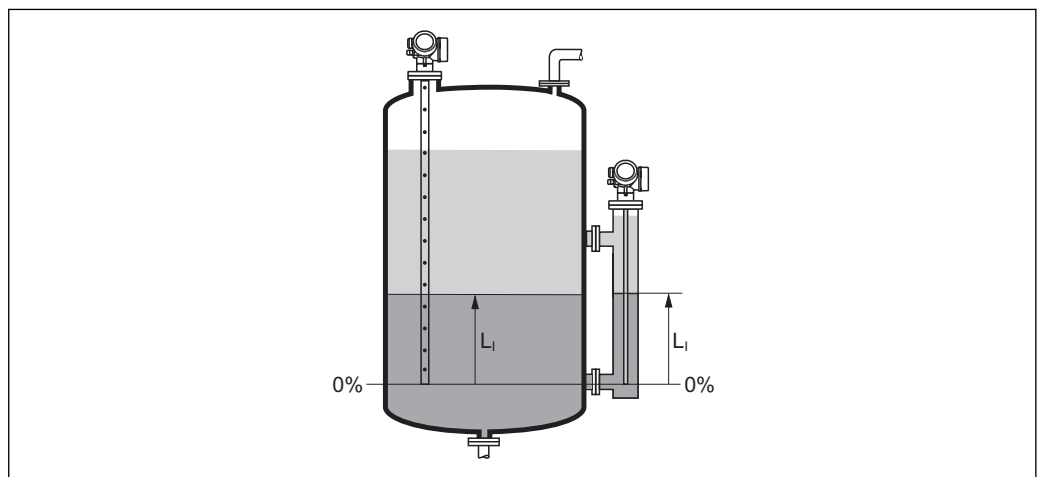

A0013197



The unit is defined in the **Level unit** parameter (→ 157).

Interface distance

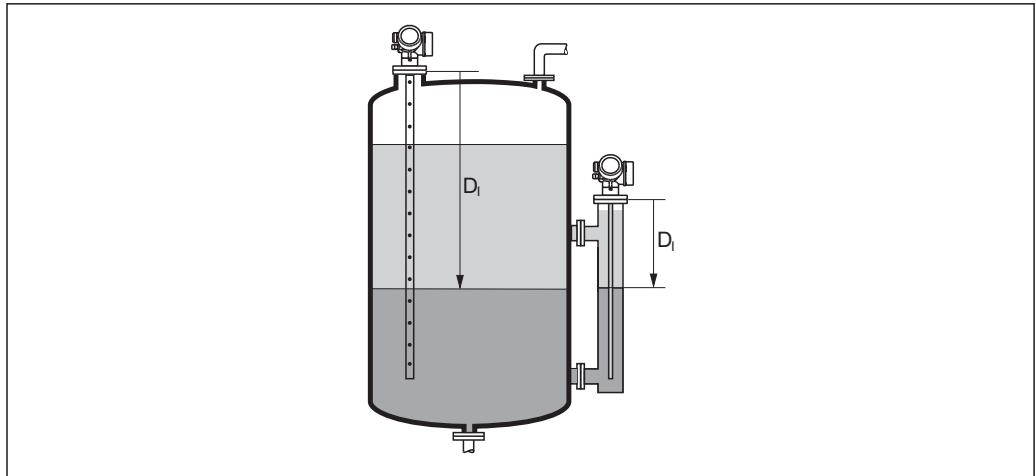
Navigation
 Setup → Interface dist.
Prerequisite
Operating mode (→  138) = **Interface** or **Interface with capacitance**
Description
 Displays the measured distance D_1 between the reference point (lower edge of flange or threaded connection) and the interface.
Additional information

A0013202

 The unit is defined in the **Distance unit** parameter (→  138).

Confirm distance

**Navigation**
 Setup → Confirm distance
Description

Specify, whether the measured distance matches the real distance.

Depending on the selection the device automatically sets the range of mapping.

Selection

- Manual map
- Distance ok
- Distance unknown
- Distance too small*
- Distance too big*
- Tank empty
- Delete map

Factory setting

Distance unknown

 * Visibility depends on order options or device settings

Additional information**Meaning of the options**

- **Manual map**

To be selected if the range of mapping is to be defined manually in the **Mapping end point** parameter (→  150). In this case it is not necessary to confirm the distance.

- **Distance ok**

To be selected if the measured distance matches the actual distance. The device performs a mapping.

- **Distance unknown**

To be selected if the actual distance is unknown. A mapping can not be performed in this case.

- **Distance too small**

To be selected if the measured distance is smaller than the actual distance. The device searches for the next echo and returns to the **Confirm distance** parameter. The distance is recalculated and displayed. The comparison must be repeated until the displayed distance matches the actual distance. After this, the recording of the map can be started by selecting **Distance ok**.

- **Distance too big**¹⁰⁾

To be selected if the measured distance exceeds the actual distance. The device adjusts the signal evaluation and returns to the **Confirm distance** parameter. The distance is recalculated and displayed. The comparison must be repeated until the displayed distance matches the actual distance. After this, the recording of the map can be started by selecting **Distance ok**.

- **Tank empty**

To be selected if the tank is completely empty. The device records a mapping covering the complete measuring range.

To be selected if the tank is completely empty. The device records a mapping covering the complete measuring range minus **Map gap to LN**.

- **Factory map**

To be selected if the present mapping curve (if one exists) is to be deleted. The device returns to the **Confirm distance** parameter and a new mapping can be recorded.



When operating via the display module, the measured distance is displayed together with this parameter for reference purposes.



For interface measurements the distance always refers to the total level (not the interface level).



If the teaching procedure with the **Distance too small** option or the **Distance too big** option is quit before the distance has been confirmed, a map is **not** recorded and the teaching procedure is reset after 60 s.



For FMP54 with gas phase compensation (product structure: feature 540 "Application Package", option EF or EG) a map must **not** be recorded.

Present mapping

Navigation

Setup → Present mapping

Description

Indicates up to which distance a mapping has already been recorded.

10) Only available for "Expert → Sensor → Echo tracking → **Evaluation mode** parameter" = "Short time history" or "Long time history"



Mapping end point

Navigation	Setup → Map. end point
Prerequisite	Confirm distance (→ 148) = Manual map or Distance too small
Description	Specify new end of the mapping.
User entry	0 to 200 000.0 m
Factory setting	0.1 m
Additional information	<p>This parameter defines up to which distance the new mapping is to be recorded. The distance is measured from the reference point, i.e. from the lower edge of the mounting flange or the threaded connection.</p> <p> For reference purposes the Present mapping parameter (→ 149) is displayed together with this parameter. It indicates up to which distance a mapping has already been recorded.</p>

Record map

Navigation	Setup → Record map
Prerequisite	Confirm distance (→ 148) = Manual map or Distance too small
Description	Start recording of the map.
Selection	<ul style="list-style-type: none"> ▪ No ▪ Record map ▪ Delete map
Factory setting	No
Additional information	<p>Meaning of the options</p> <ul style="list-style-type: none"> ▪ No The map is not recorded. ▪ Record map The map is recorded. After the recording is completed, the new measured distance and the new mapping range appear on the display. When operating via the local display, these values must be confirmed by pressing <input checked="" type="checkbox"/>. ▪ Delete map The mapping (if one exists) is deleted and the device displays the recalculated measured distance and the mapping range. When operating via the local display, these values must be confirmed by pressing <input checked="" type="checkbox"/>.

16.3.1 "Mapping" wizard

-  The **Mapping** wizard is only available when operating via the local display. When operating via an operating tool, all parameters concerning the mapping are located directly in the **Setup** menu (→  138).
-  In the **Mapping** wizard two parameters are displayed simultaneously on the display module at any one time. The upper parameter can be edited, whereas the lower parameter is displayed for reference purposes only.

Navigation  Setup → Mapping

Confirm distance

Navigation  Setup → Mapping → Confirm distance

Description →  148

Mapping end point

Navigation  Setup → Mapping → Map. end point

Description →  150

Record map

Navigation  Setup → Mapping → Record map

Description →  150

Distance





Navigation  Setup → Mapping → Distance

Description →  143





16.3.2 "Advanced setup" submenu

Navigation  Setup → Advanced setup







Locking status

Navigation	  Setup → Advanced setup → Locking status
Description	Indicates the write protection with the highest priority that is currently active.
User interface	<ul style="list-style-type: none"> ▪ Hardware locked ▪ SIL locked ▪ WHG locked ▪ Temporarily locked
Additional information	<p>Meaning and priorities of the types of write protection</p> <ul style="list-style-type: none"> ▪ Hardware locked (priority 1) The DIP switch for hardware locking is activated on the main electronics module. This locks write access to the parameters. ▪ SIL locked (priority 2) The SIL mode is activated. Writing access to the relevant parameters is denied. ▪ WHG locked (priority 3) The WHG mode is activated. Writing access to the relevant parameters is denied. ▪ Temporarily locked (priority 4) Write access to the parameters is temporarily locked on account of internal processes in progress in the device (e.g. data upload/download, reset etc.). The parameters can be modified as soon as the processes are complete. <p> On the display module, the -symbol appears in front of parameters that cannot be modified since they are write-protected.</p>







Access status tooling

Navigation	 Setup → Advanced setup → Access stat.tool
Description	Indicates access authorization to parameters via operating tool (e.g. FieldCare).
User interface	<ul style="list-style-type: none"> ▪ Operator ▪ Maintenance ▪ Service
Additional information	<p> The access authorization can be changed via the Enter access code parameter (→  153).</p> <p> If additional write protection is active, this restricts the current access authorization even further. The write protection status can be viewed via the Locking status parameter (→  152).</p>

Access status display

Navigation	 Setup → Advanced setup → Access stat.disp
Prerequisite	The device has a local display.
Description	Indicates access authorization to parameters via local display.
User interface	<ul style="list-style-type: none"> ▪ Operator ▪ Maintenance ▪ Service
Additional information	<p> If a  symbol appears in front of a parameter, the parameter cannot be changed via the local display with the current access authorization.</p> <p> The access authorization can be changed via the Enter access code parameter (→  153).</p> <p> If additional write protection is active, this restricts the current access authorization even further. The write protection status can be viewed via the Locking status parameter (→  152).</p>

Enter access code



Navigation	  Setup → Advanced setup → Ent. access code
Description	Enter access code to disable write protection of parameters.
User entry	0 to 9999
Additional information	<ul style="list-style-type: none"> ▪ For local operation, the customer-specific access code, which has been defined in the Define access code parameter (→  204), has to be entered. ▪ If an incorrect access code is entered, the user retains his current access authorization. ▪ The write protection affects all parameters marked with the -symbol in this document. On the local display, the -symbol in front of a parameter indicates that the parameter is write-protected. ▪ If no key is pressed for 10 min, or the user switches from the navigation and editing mode back to the measured value display mode, the device automatically locks the write-protected parameters after another 60 s. <p> Please contact your Endress+Hauser Sales Center if you lose your access code.</p>

"Level" submenu

 The **Level** submenu (→  154) is only visible for **Operating mode** (→  138) = **Level**

Navigation   Setup → Advanced setup → Level

Medium type **Navigation**

  Setup → Advanced setup → Level → Medium type

Description

Specify type of medium.

User interface

- Liquid
- Solid

Factory setting

FMP50, FMP51, FMP52, FMP53, FMP54, FMP55: **Liquid**

Additional information

The **Solid** option is only available for **Operating mode** (→  138) = **Level**

 This parameter determines the value of several other parameters and strongly influences the complete signal evaluation. Therefore, it is strongly recommended **not to change** the factory setting.

Medium property **Navigation**

  Setup → Advanced setup → Level → Medium property

Prerequisite

- **Operating mode** (→  138) = **Level**
- **EOP level evaluation** ≠ **Fix DC**



Description

Specify relative dielectric constant ϵ_r of the medium.

Selection

- Unknown
- DC 1.4 ... 1.6
- DC 1.6 ... 1.9
- DC 1.9 ... 2.5
- DC 2.5 ... 4
- DC 4 ... 7
- DC 7 ... 15
- DC > 15

Factory setting

Dependent on **Medium type** (→  154) and **Medium group** (→  140).

Additional information

Dependency on "Medium type" and "Medium group"

Medium type (→ ⓘ 154)	Medium group (→ ⓘ 140)	Medium property
Solid		Unknown
Liquid	Water based (DC >= 4)	DC 4 ... 7
	Others	Unknown

-  For dielectric constants (DC values) of many media commonly used in various industries refer to:
 - the Endress+Hauser DC manual (CP01076F)
 - the Endress+Hauser "DC Values App" (available for Android and iOS)

-  For **EOP level evaluation = Fix DC**, the exact dielectric constant has to be entered into the **DC value** parameter (→ ⓘ 146). Therefore, the **Medium property** parameter is not available in this case.

Process property



Navigation

  Setup → Advanced setup → Level → Process property

Description

Specify typical rate of level change.

Selection

- For "Medium type" = "Liquid"**
- Very fast > 10 m (400 in)/min
 - Fast > 1 m (40 in)/min
 - Standard < 1 m (40in) /min
 - Medium < 10 cm (4in) /min
 - Slow < 1 cm (0.4in) /min
 - No filter / test
- For "Medium type" = "Solid"**
- Very fast > 100 m (333 ft) /h
 - Fast > 10 m (33 ft) /h
 - Standard < 10 m (33 ft) /h
 - Medium < 1 m (3ft) /h
 - Slow < 0.1 m (0.3ft) /h
 - No filter / test

Factory setting

Standard < 1 m (40in) /min

Additional information

The device adjusts the signal evaluation filters and the damping of the output signal to the typical rate of level change defined in this parameter:

For "Operating mode" = "Level" and "Medium type" = "Liquid"

Process property	Step response time / s
Very fast > 10 m (400 in)/min	5
Fast > 1 m (40 in)/min	5
Standard < 1 m (40in) /min	14
Medium < 10 cm (4in) /min	39
Slow < 1 cm (0.4in) /min	76
No filter / test	< 1

For "Operating mode" = "Level" and "Medium type" = "Solid"

Process property	Step response time / s
Very fast > 100 m (333 ft) /h	37
Fast > 10 m (33 ft) /h	37
Standard < 10 m (33 ft) /h	74
Medium < 1 m (3ft) /h	146
Slow < 0.1 m (0.3ft) /h	290
No filter / test	< 1

For "Operating mode" = "Interface" or "Interface with capacitance"

Process property	Step response time / s
Very fast > 10 m (400 in)/min	5
Fast > 1 m (40 in)/min	5
Standard < 1 m (40in) /min	23
Medium < 10 cm (4in) /min	47
Slow < 1 cm (0.4in) /min	81
No filter / test	2.2

Advanced process conditions



Navigation

Setup → Advanced setup → Level → Adv. conditions

Prerequisite

Operating mode (→ 138) = Level

Description

Specify additional process conditions (if required).

Selection

- None
- Oil/Water condensate
- Probe near tank bottom
- Build up
- Foam (>5cm/0,16ft)

Factory setting





None

Additional information





Meaning of the options

- **Oil/Water condensate** (only **Medium type = Liquid**)
Makes sure that in the case of two-phase media only the total level is detected (example: oil/condensate application).
- **Probe near tank bottom** (only for **Medium type = Liquid**)
Improves the empty detection, especially if the probe is mounted close to the tank bottom.
- **Build up**
Increases **EOP range upper area** in order to ensure a safe empty-detection even if the end-of-probe signal has shifted due to build-up.
Enables a safe empty-detection even if the end-of-probe signal has shifted due to build-up.
- **Foam (>5cm/0,16ft)** (only for **Medium type = Liquid**)
Optimizes the signal evaluation in applications with foam formation.

Level unit

Navigation	  Setup → Advanced setup → Level → Level unit								
Description	Select level unit.								
Selection	<table> <thead> <tr> <th><i>SI units</i></th> <th><i>US units</i></th> </tr> </thead> <tbody> <tr> <td>■ %</td> <td>■ ft</td> </tr> <tr> <td>■ m</td> <td>■ in</td> </tr> <tr> <td>■ mm</td> <td></td> </tr> </tbody> </table>	<i>SI units</i>	<i>US units</i>	■ %	■ ft	■ m	■ in	■ mm	
<i>SI units</i>	<i>US units</i>								
■ %	■ ft								
■ m	■ in								
■ mm									
Factory setting	%								
Additional information	<p>The level unit may differ from the distance unit defined in the Distance unit parameter (→  138):</p> <ul style="list-style-type: none"> ■ The unit defined in the Distance unit parameter is used for the basic calibration (Empty calibration (→  140) and Full calibration (→  141)). ■ The unit defined in the Level unit parameter is used to display the (nonlinearized) level. 								

Blocking distance

Navigation	  Setup → Advanced setup → Level → Blocking dist.
Description	Specify upper blocking distance UB.
User entry	0 to 200 m
Factory setting	<ul style="list-style-type: none"> ■ For coax probes: 0 mm (0 in) ■ For rod and rope probes up to 8 m (26 ft): 200 mm (8 in) ■ For rod and rope probes above 8 m (26 ft): 0.025 * Sondenlänge
Additional information	<p>Signals in the upper blocking distance are only evaluated if they have been outside the blocking distance when the device was switched on and move into the blocking distance due to a level change during operation. Signals which are already in the blocking distance when the device is switched on, are ignored.</p> <p> This behavior is only valid if the following two conditions are met:</p> <ul style="list-style-type: none"> ■ Expert → Sensor → Echo tracking → Evaluation mode = Short time history or Long time history) ■ Expert → Sensor → Gas phase comp. → GPC mode= On, Without correction or External correction <p>If one of these conditions is not met, signals in the blocking distance will always be ignored.</p> <p> A different behavior for signals in the blocking distance can be defined in the Blocking distance evaluation mode parameter.</p> <p> If required, a different behavior for signals in the blocking distance can be defined by the Endress+Hauser service.</p>

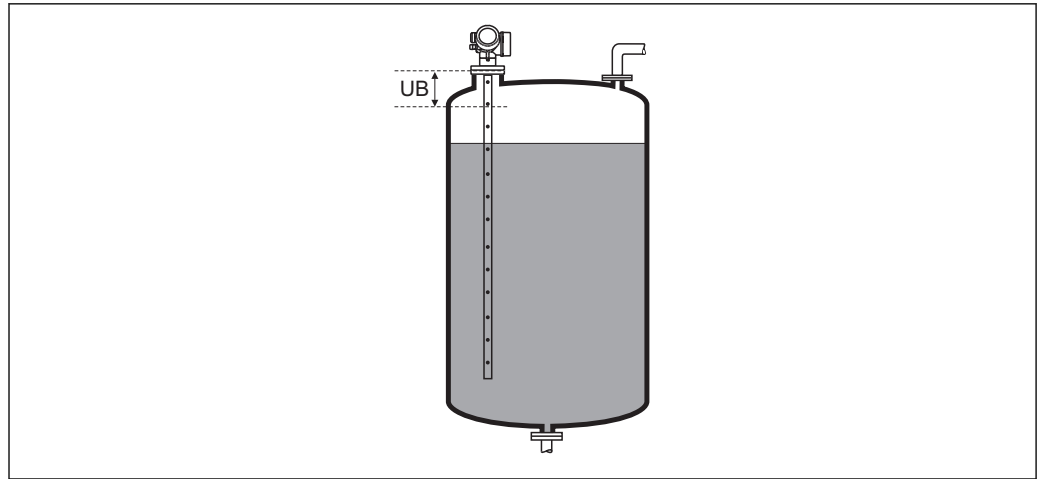

A0013219

41 Blocking distance (UB) for liquid measurements

Level correction



Navigation	 Setup → Advanced setup → Level → Level correction
Description	Specify level correction (if required).
User entry	-200 000.0 to 200 000.0 %
Factory setting	0.0 %
Additional information	The value specified in this parameter is added to the measured level (before linearization).

"Interface" submenu

Navigation  Setup → Advanced setup → Interface

Process property 

Navigation  Setup → Advanced setup → Interface → Process property

Description Specify typical rate of change for the interface position.

- Selection**
- Fast > 1 m (40 in)/min
 - Standard < 1 m (40in) /min
 - Medium < 10 cm (4in) /min
 - Slow < 1 cm (0.4in) /min
 - No filter / test

Factory setting Standard < 1 m (40in) /min

Additional information The device adjusts the signal evaluation filters and the damping of the output signal to the typical rate of level change defined in this parameter:

Process property	Step response time / s
Fast > 1 m (40 in)/min	5
Standard < 1 m (40in) /min	15
Medium < 10 cm (4in) /min	40
Slow < 1 cm (0.4in) /min	74
No filter / test	2.2

DC value lower medium 

Navigation  Setup → Advanced setup → Interface → DC lower medium

Prerequisite **Operating mode** (→  138) = **Interface** or **Interface with capacitance**

Description Specify the relative dielectric constant ϵ_r of the lower medium.

User entry 1 to 100

Factory setting 80.0

Additional information

-  For dielectric constants (DC values) of many media commonly used in various industries refer to:
 - the Endress+Hauser DC manual (CP01076F)
 - the Endress+Hauser "DC Values App" (available for Android and iOS)

 The factory setting, $\epsilon_r = 80$, is valid for water at 20 °C (68 °F).

Level unit

Navigation Setup → Advanced setup → Interface → Level unit

Description Select level unit.

Selection

<i>SI units</i>	<i>US units</i>
■ %	■ ft
■ m	■ in
■ mm	

Factory setting %

Additional information The level unit may differ from the distance unit defined in the **Distance unit** parameter (→ 138):

- The unit defined in the **Distance unit** parameter is used for the basic calibration (**Empty calibration** (→ 140) and **Full calibration** (→ 141)).
- The unit defined in the **Level unit** parameter is used to display the (unlinearized) level and interface position.

Blocking distance

Navigation Setup → Advanced setup → Interface → Blocking dist.

Description Specify upper blocking distance UB.

User entry 0 to 200 m

Factory setting

- For coax probes: 100 mm (3.9 in)
- For rod and rope probes up to 8 m (26 ft): 200 mm (8 in)
- For rod and rope probes above 8 m (26 ft): 0.025 * length of probe

Additional information Echoes from within the blocking distance are not taken into account in the signal evaluation. The upper blocking distance is used

- to suppress interference echoes at the top end of the probe.
- to suppress the echo of the total level in the case of flooded bypasses.

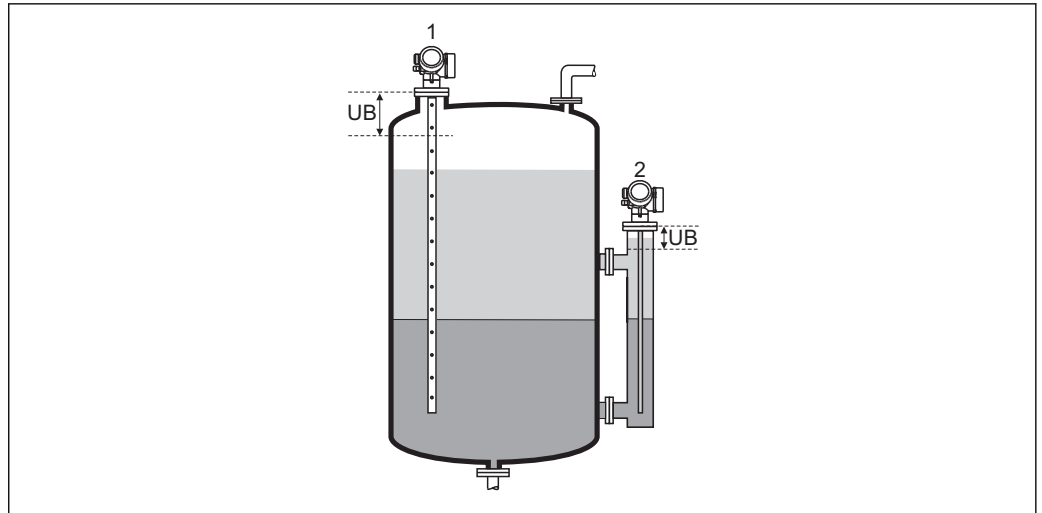

A0013220

- 1 Suppression of interference echoes at the top end of the probe.
- 2 Suppression of the level signal in case of a flooded bypass.
- UB Upper blocking distance

Level correction



Navigation	☰☰ Setup → Advanced setup → Interface → Level correction
Description	Specify level correction (if required).
User entry	-200 000.0 to 200 000.0 %
Factory setting	0.0 %
Additional information	The value specified in this parameter is added to the measured total and interface levels (before linearization).

Manual thickness upper layer



Navigation	☰ Setup → Advanced setup → Interface → Man.thick.up.lay
Description	Specify the manually determined interface thickness UP (i.e. the thickness of the upper medium).
User entry	0 to 200 m
Factory setting	0 m

Additional information

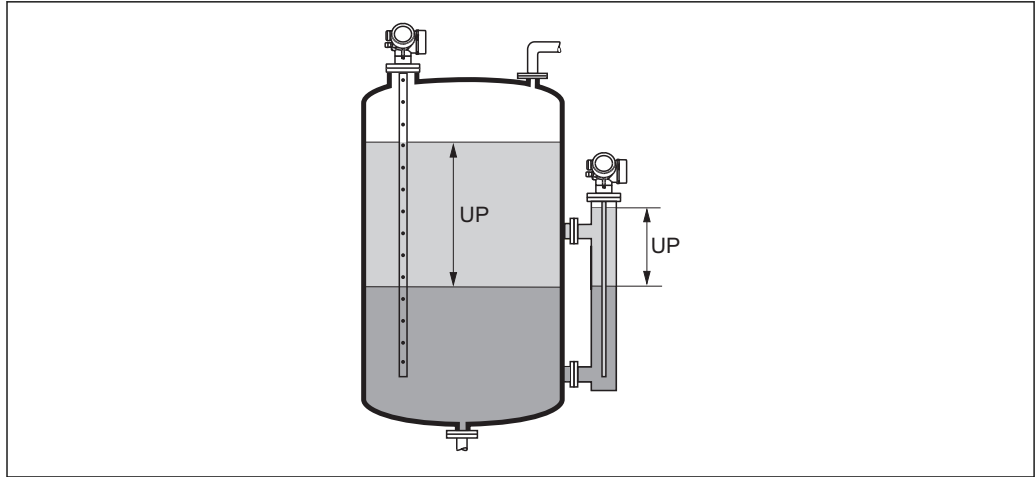

A0013313

UP Interface thickness (= thickness of upper medium)

 On the local display, the measured interface thickness is indicated together with the manual interface thickness. By comparing these two values the device can automatically adjust the dielectric constant of the upper medium.

Measured thickness upper layer

Navigation  Setup → Advanced setup → Interface → Meas.thick.u.lay

Description Displays the measured interface thickness. (Thickness UP of the upper medium).

DC value



Navigation  Setup → Advanced setup → Interface → DC value

Description Displays relative dielectric constant ϵ_r of the upper medium (DC₁) before correction.

Calculated DC value

Navigation  Setup → Advanced setup → Interface → Calc. DC value

Description Displays calculated (i.e. corrected) relative dielectric constant ϵ_r (DC1) of the upper medium.

Use calculated DC value

**Navigation**

Setup → Advanced setup → Interface → Use calc. DC

Description

Specify whether the calculated dielectric constant is to be used.

Selection

- Save and exit
- Cancel and exit

Factory setting

Cancel and exit



Additional information**Meaning of the options**

- Save and exit
The calculated constant is assumed to be the correct one.
- Cancel and exit
The calculated dielectric constant is rejected; the previous dielectric constant remains active.



On the local display, the **Calculated DC value** parameter (→ 162) is displayed together with this parameter.

"Automatic DC calculation" wizard

-  The **Automatic DC calculation** wizard is only available when operating via the local display. When operating via an operating tool, all parameters concerning the automatic DC calculation are located directly in the **Interface** submenu (→  159)
-  In the **Automatic DC calculation** wizard two parameters are displayed simultaneously on the display module at any one time. The upper parameter can be edited, whereas the lower parameter is displayed for reference purposes only.

Navigation  Setup → Advanced setup → Interface → Autom. DC calc.

Manual thickness upper layer

Navigation  Setup → Advanced setup → Interface → Autom. DC calc. → Man.thick.up.lay

Description →  161

DC value

Navigation  Setup → Advanced setup → Interface → Autom. DC calc. → DC value

Description →  162

Use calculated DC value

Navigation  Setup → Advanced setup → Interface → Autom. DC calc. → Use calc. DC

Description →  163

"Linearization" submenu

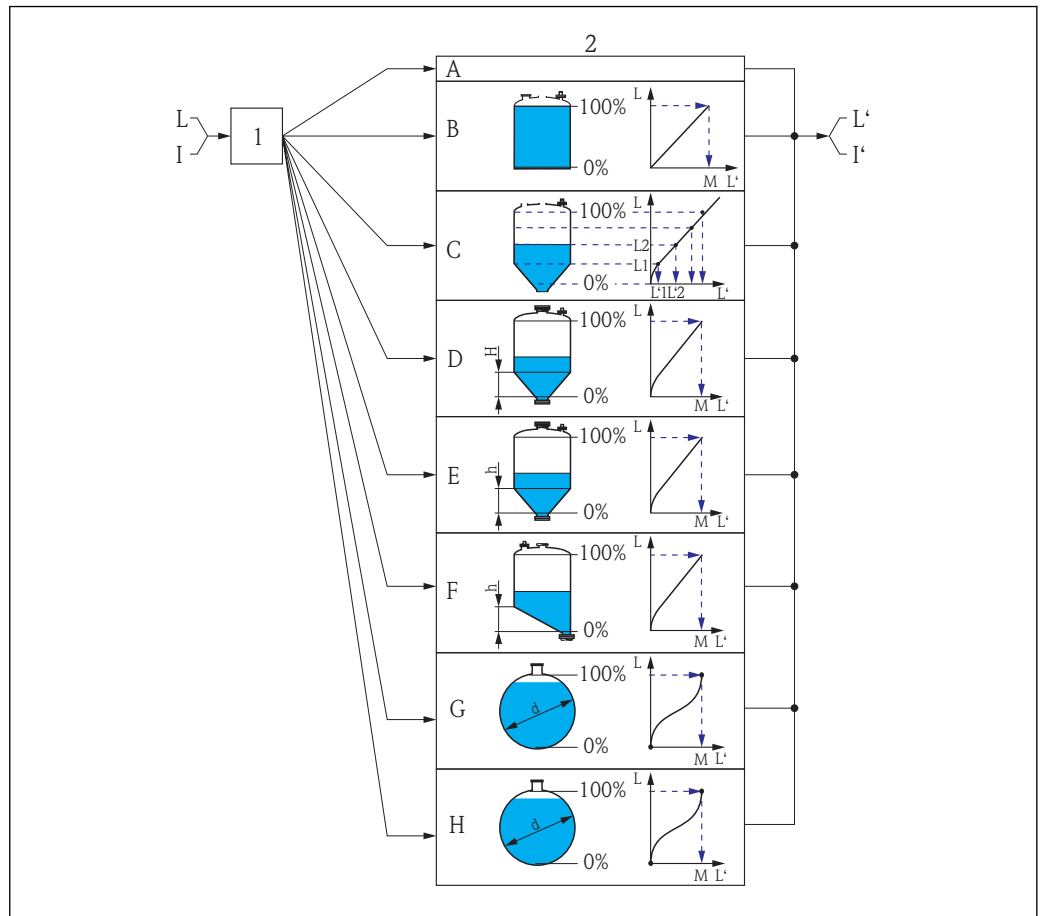











A0016084

42 Linearization: Transformation of the level and (if relevant) the interface height into a volume or weight; the transformation is dependent on the shape of the vessel.

- 1 Selection of linearization type and unit
- 2 Configuration of the linearization
- A Linearization type (→ 168) = None
- B Linearization type (→ 168) = Linear
- C Linearization type (→ 168) = Table
- D Linearization type (→ 168) = Pyramid bottom
- E Linearization type (→ 168) = Conical bottom
- F Linearization type (→ 168) = Angled bottom
- G Linearization type (→ 168) = Horizontal cylinder
- H Linearization type (→ 168) = Sphere
- I For "Operating mode (→ 138)" = "Interface" or "Interface with capacitance": Interface before linearization (measured in distance units)
- I' For "Operating mode (→ 138)" = "Interface" or "Interface with capacitance": Interface after linearization (corresponds to volume or weight)
- L Level before linearization (measured in distance units)
- L' Level linearized (→ 170) (corresponds to volume or weight)
- M Maximum value (→ 171)
- d Diameter (→ 171)
- h Intermediate height (→ 172)















Structure of the submenu on the display module

Navigation  Setup → Advanced setup → Linearization

► Linearization		
Linearization type		→  168
Unit after linearization		→  169
Free text		→  170
Maximum value		→  171
Diameter		→  171
Intermediate height		→  172
Table mode		→  172
► Edit table		
	Level	→  174
	Customer value	→  174
	Activate table	→  174

Structure of the submenu in an operating tool (e.g. FieldCare)

Navigation  Setup → Advanced setup → Linearization

► Linearization	
Linearization type	→  168
Unit after linearization	→  169
Free text	→  170
Level linearized	→  170
Interface linearized	→  171
Maximum value	→  171
Diameter	→  171
Intermediate height	→  172
Table mode	→  172
Table number	→  173
Level	→  174
Level	→  174
Customer value	→  174
Activate table	→  174

Description of parameters

Navigation  Setup → Advanced setup → Linearization

Linearization type 

Navigation  Setup → Advanced setup → Linearization → Lineariz. type

Description Select linearization type.

- Selection**
- None
 - Linear
 - Table
 - Pyramid bottom
 - Conical bottom
 - Angled bottom
 - Horizontal cylinder
 - Sphere

Factory setting None

Additional information

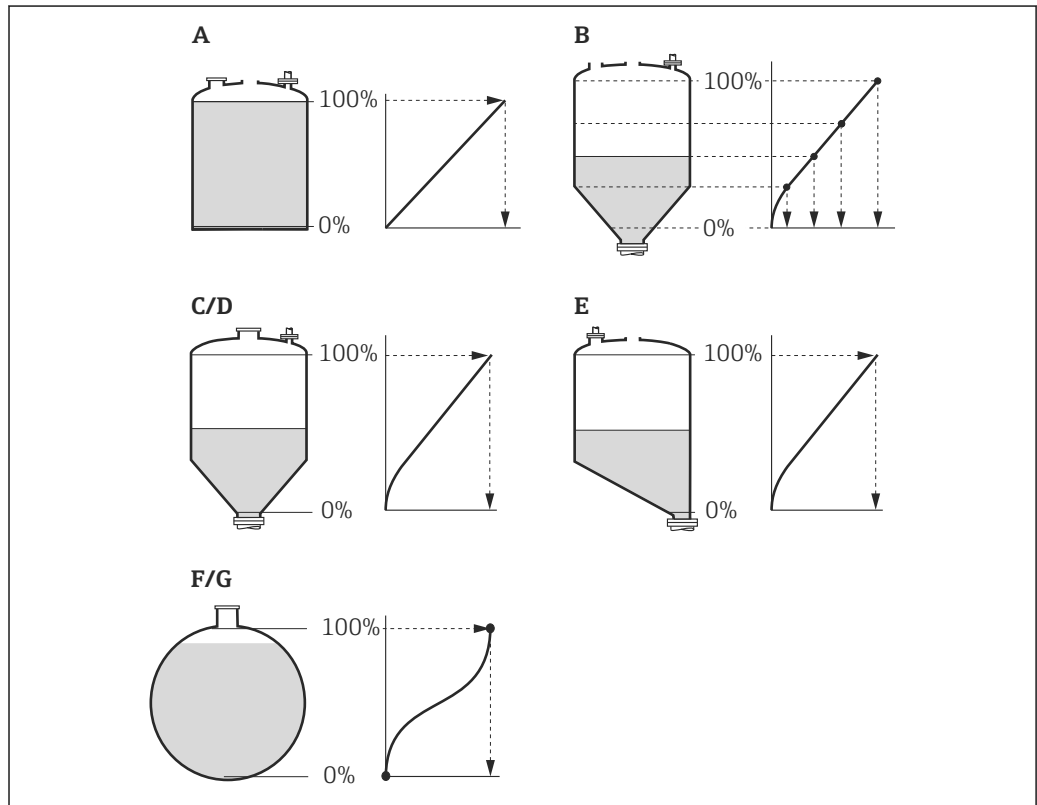

 43 *Linearization types*

- A *None*
- B *Table*
- C *Pyramid bottom*
- D *Conical bottom*
- E *Angled bottom*
- F *Sphere*
- G *Horizontal cylinder*



Meaning of the options

■ **None**

The level is transmitted in the level unit without linearization.





■ **Linear**

The output value (volume/weight) is directly proportional to the level L. This is valid, for example, for vertical cylinders. The following additional parameters have to be specified:

- **Unit after linearization** (→  169)
- **Maximum value** (→  171): Maximum volume or weight



■ **Table**

The relationship between the measured level L and the output value (volume/weight) is given by a linearization table consisting of up to 32 pairs of values "level - volume" or "level - weight", respectively. The following additional parameters have to be specified:

- **Unit after linearization** (→  169)
- **Table mode** (→  172)
- For each table point: **Level** (→  174)
- For each table point: **Customer value** (→  174)
- **Activate table** (→  174)



■ **Pyramid bottom**

The output value corresponds to the volume or weight in a silo with pyramid bottom. The following additional parameters have to be specified:

- **Unit after linearization** (→  169)
- **Maximum value** (→  171): Maximum volume or weight
- **Intermediate height** (→  172): The height of the pyramid



■ **Conical bottom**

The output value corresponds to the volume or weight in a tank with conical bottom. The following additional parameters have to be specified:

- **Unit after linearization** (→  169)
- **Maximum value** (→  171): Maximum volume or weight
- **Intermediate height** (→  172): The height of the conical part of the tank



■ **Angled bottom**

The output value corresponds to the volume or weight in a silo with an angled bottom. The following additional parameters have to be specified:

- **Unit after linearization** (→  169)
- **Maximum value** (→  171): Maximum volume or weight
- **Intermediate height** (→  172): Height of the angled bottom



■ **Horizontal cylinder**

The output value corresponds to the volume or weight in a horizontal cylinder. The following additional parameters have to be specified:

- **Unit after linearization** (→  169)
- **Maximum value** (→  171): Maximum volume or weight
- **Diameter** (→  171)

■ **Sphere**



The output value corresponds to the volume or weight in a spherical tank. The following additional parameters have to be specified:

- **Unit after linearization** (→  169)
- **Maximum value** (→  171): Maximum volume or weight
- **Diameter** (→  171)

Unit after linearization



Navigation

  Setup → Advanced setup → Linearization → Unit lineariz.

Prerequisite

Linearization type (→  168) ≠ None



Description

Select unit of the linealized value.



Selection	<i>SI units</i> <ul style="list-style-type: none"> ■ STon ■ t ■ kg ■ cm³ ■ dm³ ■ m³ ■ hl ■ l ■ % <i>Custom-specific units</i> Free text	<i>US units</i> <ul style="list-style-type: none"> ■ lb ■ UsGal ■ ft³ 	<i>Imperial units</i> impGal
------------------	--	---	---------------------------------

Factory setting %

Additional information The selected unit is only used to be indicated on the display. The measured value is **not** transformed according to the selected unit.

 It is also possible to configure a distance-to-distance linearization, i.e. a transformation from the level unit to a different distance unit. To do so, select the **Linear** linearization mode. In order to define the new level unit, select the **Free text** option in the **Unit after linearization** parameter and enter the required unit into the **Free text** parameter (→  170).

Free text 

Navigation   Setup → Advanced setup → Linearization → Free text

Prerequisite **Unit after linearization** (→  169) = **Free text**

Description Enter unit symbol.

User entry Up to 32 alphanumerical characters (letters, numbers, special characters)

Factory setting Free text

Level linearized





Navigation  Setup → Advanced setup → Linearization → Level linearized

Description Displays linearized level.

Additional information 



- The unit is defined by the **Unit after linearization** parameter →  169.
- For interface measurements, this parameter always refers to the total level.

Interface linearized

Navigation	 Setup → Advanced setup → Linearization → Interf. lineariz
Prerequisite	Operating mode (→  138) = Interface or Interface with capacitance
Description	Displays the linearized interface height.
Additional information	 The unit is defined in the Unit after linearization parameter (→  169).





Maximum value



Navigation	  Setup → Advanced setup → Linearization → Maximum value
Prerequisite	Linearization type (→  168) has one of the following values: <ul style="list-style-type: none"> ▪ Linear ▪ Pyramid bottom ▪ Conical bottom ▪ Angled bottom ▪ Horizontal cylinder ▪ Sphere
Description	Specify the maximum content of the vessel (100%) measured in the units after linearization.
User entry	-50 000.0 to 50 000.0 %
Factory setting	100.0 %

Diameter



Navigation	  Setup → Advanced setup → Linearization → Diameter
Prerequisite	Linearization type (→  168) has one of the following values: <ul style="list-style-type: none"> ▪ Horizontal cylinder ▪ Sphere
Description	Specify tank diameter.
User entry	0 to 9 999.999 m
Factory setting	2 m
Additional information	The unit is defined in the Distance unit parameter (→  138).

Intermediate height



Navigation

Setup → Advanced setup → Linearization → Intermed. height

Prerequisite

Linearization type (→ 168) has one of the following values:

- Pyramid bottom
- Conical bottom
- Angled bottom

Description

Specify intermediate height H.

User entry

0 to 200 m

Factory setting

0 m

Additional information

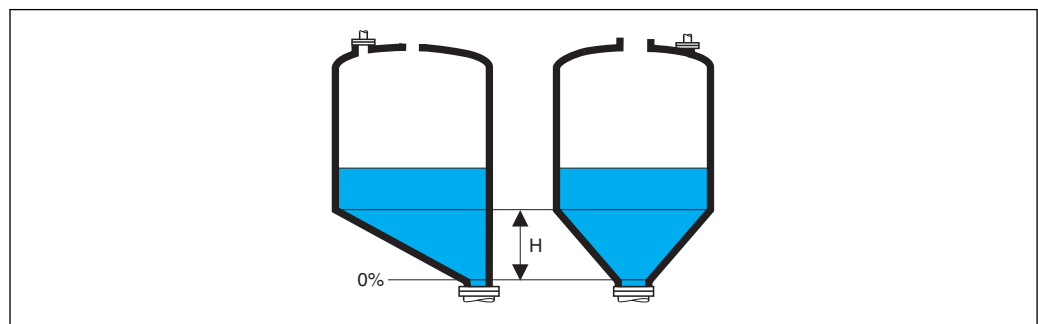

A0013264

H Intermediate height

The unit is defined in the **Distance unit** parameter (→ 138).

Table mode



Navigation

Setup → Advanced setup → Linearization → Table mode

Prerequisite

Linearization type (→ 168) = Table

Description

Select editing mode of the linearization table.

Selection

- Manual
- Semiautomatic
- Clear table
- Sort table

Factory setting

Manual



Additional information

Meaning of the options

- **Manual**
The level and the associated linearized value are entered manually for each linearization point.
- **Semiautomatic**
The level is measured by the device for each linearization point. The associated linearized value is entered manually.
- **Clear table**
Deletes the existing linearization table.
- **Sort table**
Rearranges the linearization points into an ascending order.



Conditions the linearization table must meet:



- The table may consist of up to 32 pairs of values "Level - Linearized Value".
- The table must be monotonic (monotonically increasing or decreasing).
- The first linearization point must refer to the minimum level.
- The last linearization point must refer to the maximum level.

 Before entering a linearization table, the values for **Empty calibration** (→  140) and **Full calibration** (→  141) must be set correctly.

If values of the table need to be changed after the full or empty calibration have been changed, a correct evaluation is only ensured if the existing table is deleted and the complete table is entered again. To do so delete the existing table (**Table mode** (→  172) = **Clear table**). Then enter a new table.

How to enter the table

- **Via FieldCare**
The table points can be entered via the **Table number** (→  173), **Level** (→  174) and **Customer value** (→  174) parameters. As an alternative, the graphic table editor may be used: Device Operation → Device Functions → Additional Functions → Linearization (Online/Offline)
- **Via local display**
Select the **Edit table** submenu to call up the graphic table editor. The table is displayed and can be edited line by line.

 The factory setting for the level unit is "%". If you want to enter the linearization table in physical units, you must select the appropriate unit in the **Level unit** parameter (→  157) beforehand.





 If a decreasing table is entered, the values for 20 mA and 4 mA of the current output are interchanged. That means: 20 mA refers to the lowest level, whereas 4 mA refers to the highest level. If required, the current output can be inverted in the **Measuring mode** parameter.

Table number	
<hr/>	
Navigation	 Setup → Advanced setup → Linearization → Table number
Prerequisite	Linearization type (→  168) = Table
Description	Select table point you are going to enter or change.
User entry	1 to 32
Factory setting	1

Level (Manual)



Navigation	Setup → Advanced setup → Linearization → Level
Prerequisite	<ul style="list-style-type: none"> ▪ Linearization type (→ 168) = Table ▪ Table mode (→ 172) = Manual
Description	Enter level value of the table point (value before linearization).
User entry	Signed floating-point number
Factory setting	0 %

Level (Semiautomatic)

Navigation	Setup → Advanced setup → Linearization → Level
Prerequisite	<ul style="list-style-type: none"> ▪ Linearization type (→ 168) = Table ▪ Table mode (→ 172) = Semiautomatic
Description	Displays measured level (value before linearization). This value is transmitted to the table.

Customer value



Navigation	Setup → Advanced setup → Linearization → Customer value
Prerequisite	Linearization type (→ 168) = Table
Description	Enter linearized value for the table point.
User entry	Signed floating-point number
Factory setting	0 %

Activate table



Navigation	Setup → Advanced setup → Linearization → Activate table
Prerequisite	Linearization type (→ 168) = Table
Description	Activate (enable) or deactivate (disable) the linearization table.
Selection	<ul style="list-style-type: none"> ▪ Disable ▪ Enable

Factory setting

Disable

Additional information**Meaning of the options****■ Disable**

The measured level is not linearized.

If **Linearization type** (→  **168**) = **Table** at the same time, the device issues error message F435.

■ Enable

The measured level is linearized according to the table.



When editing the table, the **Activate table** parameter is automatically reset to **Disable** and must be reset to **Enable** after the table has been entered.

"Safety settings" submenu

Navigation  Setup → Advanced setup → Safety sett.

Output echo lost **Navigation**

 Setup → Advanced setup → Safety sett. → Output echo lost

Description

Define the behavior of the output signal in case of a lost echo.



Selection

- Last valid value
- Ramp at echo lost
- Value echo lost
- Alarm

Factory setting

Last valid value

Additional information**Meaning of the options**

- **Last valid value**
The last valid value is kept in the case of a lost echo.
- **Ramp at echo lost**
In the case of a lost echo the output value is continuously shifted towards 0% or 100%.
The slope of the ramp is defined in the **Ramp at echo lost** parameter (→  177).
- **Value echo lost**
In the case of a lost echo the output assumes the value defined in the **Value echo lost** parameter (→  176).
- **Alarm**
In the case of a lost echo the device generates an alarm; see the **Failure mode** parameter (→  186)

Value echo lost **Navigation**

 Setup → Advanced setup → Safety sett. → Value echo lost

Prerequisite

Output echo lost (→  176) = **Value echo lost**

Description

Define output value in case of a lost echo.



User entry

0 to 200 000.0 %

Factory setting

0.0 %

Additional information

- Use the unit which has been defined for the measured value output:
- without linearization: **Level unit** (→  157)
 - with linearization: **Unit after linearization** (→  169)

Ramp at echo lost



Navigation Setup → Advanced setup → Safety sett. → Ramp echo lost

Prerequisite **Output echo lost (→ 176) = Ramp at echo lost**

Description Define the slope of the ramp in the case of a lost echo.

User entry Signed floating-point number

Factory setting 0.0 %/min

Additional information

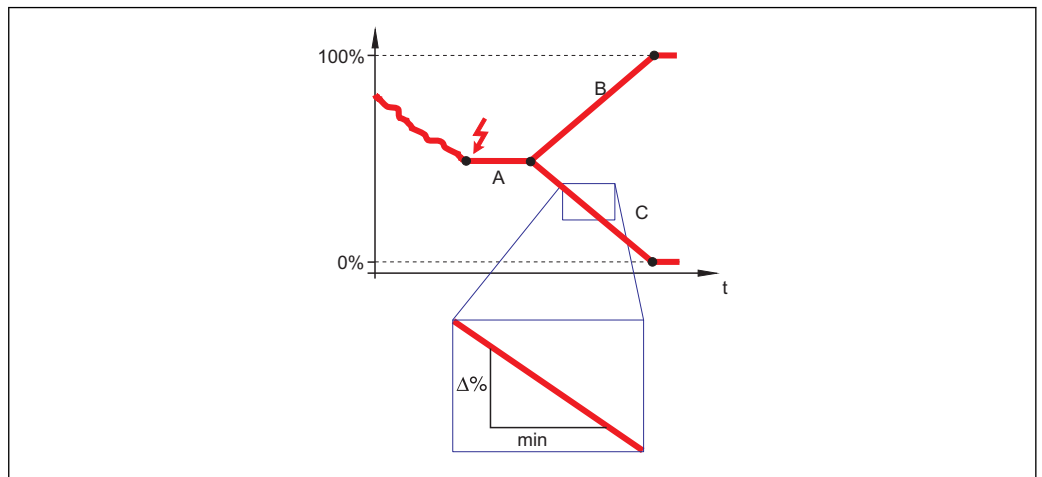

A0013269

- A Delay time echo lost
 B Ramp at echo lost (→ 177) (positive value)
 C Ramp at echo lost (→ 177) (negative value)

- The unit for the slope of the ramp is "percentage of the measuring range per minute" (%/min).
- For a negative slope of the ramp: The measured value is continuously decreased until it reaches 0%.
- For a positive slope of the ramp: The measured value is continuously increased until it reaches 100%.

Blocking distance



Navigation Setup → Advanced setup → Safety sett. → Blocking dist.

Description Specify upper blocking distance UB.

User entry 0 to 200 m

Factory setting

- For coax probes: 0 mm (0 in)
- For rod and rope probes up to 8 m (26 ft): 200 mm (8 in)
- For rod and rope probes above 8 m (26 ft): 0.025 * Sondenlänge

Additional information Signals in the upper blocking distance are only evaluated if they have been outside the blocking distance when the device was switched on and move into the blocking distance

due to a level change during operation. Signals which are already in the blocking distance when the device is switched on, are ignored.

- i** This behavior is only valid if the following two conditions are met:
- Expert → Sensor → Echo tracking → Evaluation mode = **Short time history** or **Long time history**)
 - Expert → Sensor → Gas phase comp. → GPC mode= **On, Without correction** or **External correction**

If one of these conditions is not met, signals in the blocking distance will always be ignored.

- i** A different behavior for signals in the blocking distance can be defined in the **Blocking distance evaluation mode** parameter.

- i** If required, a different behavior for signals in the blocking distance can be defined by the Endress+Hauser service.

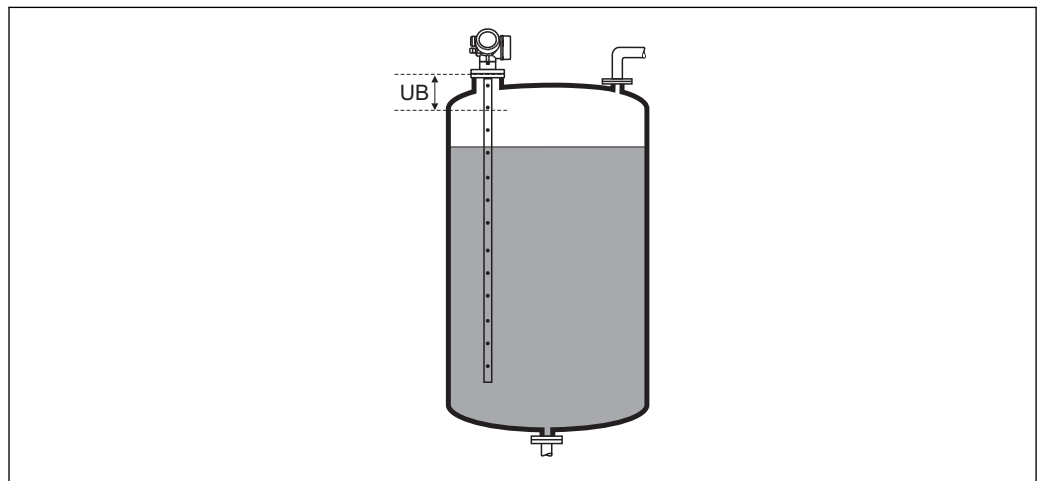

A0013219

i 44 Blocking distance (UB) for liquid measurements

"SIL/WHG confirmation" wizard

 The **SIL/WHG confirmation** wizard is only available for devices with SIL or WHG approval (Feature 590: "Additional Approval", option LA: "SIL" or LC: "WHG overflow prevention") which are currently **not** in the SIL- or WHG-locked state.

The **SIL/WHG confirmation** wizard is required to lock the device according to SIL or WHG. For details refer to the "Functional Safety Manual" of the respective device, which describes the locking procedure and the parameters of the sequence.

Navigation  Setup → Advanced setup → SIL/WHG confirm.

"Deactivate SIL/WHG" wizard

Navigation  Setup → Advanced setup → Deactiv. SIL/WHG

Reset write protection







Navigation	 Setup → Advanced setup → Deactiv. SIL/WHG → Res. write prot.
Description	Enter unlocking code.
User entry	0 to 65 535
Factory setting	0



Code incorrect





Navigation	 Setup → Advanced setup → Deactiv. SIL/WHG → Code incorrect
Description	Indicates that a wrong unlocking code has been entered. Select procedure.
Selection	<ul style="list-style-type: none"> ▪ Reenter code ▪ Abort sequence
Factory setting	Reenter code



"Probe settings" submenu

The **Probe settings** submenu helps to ensure that the end of probe signal within the envelope curve is correctly assigned by the evaluation algorithm. The assignment is correct if the length of probe indicated by the device matches the actual length of the probe. The automatic probe length correction can only be performed if the probe is installed in the vessel and is completely uncovered (no medium). For partially filled vessels and if the probe length is known, select **Confirm probe length** (→  182) = **Manual input** in order to enter the value manually.

-  If a mapping (interference echo suppression) has been recorded after shortening the probe, it is no longer possible to perform an automatic probe length correction. In this case there are two options:
 - Delete the map using the **Record map** parameter (→  150) before performing the automatic probe length correction. After the probe length correction, a new map can be recorded using the **Record map** parameter (→  150).
 - Alternative: Select **Confirm probe length** (→  182) = **Manual input** and enter the probe length manually into the **Present probe length** parameter →  181.
-  An automatic probe length correction is only possible after the correct option has been selected in the **Probe grounded** parameter (→  181).

Navigation   Setup → Advanced setup → Probe settings

Probe grounded	
<hr/>	
Navigation	  Setup → Advanced setup → Probe settings → Probe grounded
Prerequisite	Operating mode (→  138) = Level
Description	Specify whether the probe is grounded.
Selection	<ul style="list-style-type: none"> ▪ No ▪ Yes
Factory setting	No

Present probe length	
<hr/>	
Navigation	 Setup → Advanced setup → Probe settings → Pres. length
Description	<ul style="list-style-type: none"> ▪ In most cases: Displays the length of the probe according to the currently measured end-of-probe signal. ▪ For Confirm probe length (→  182) = Manual input: Enter actual length of probe.
User entry	0 to 200 m
Factory setting	4 m

Confirm probe length
**Navigation**

Setup → Advanced setup → Probe settings → Confirm length

Description

Select, whether the value displayed in the **Present probe length** parameter → 181 matches the actual length of the probe. Based on this input, the device performs a probe length correction.

Selection

- Probe length OK
- Probe length too small
- Probe length too big
- Probe covered
- Manual input
- Probe length unknown

Factory setting



Probe length OK

Additional information**Meaning of the options**

- **Probe length OK**
To be selected if the indicated length is correct. An adjustment is not required. The device quits the sequence.
- **Probe length too small**
To be selected if the displayed length is smaller than the actual length of the probe. A different end of probe signal is allocated and the newly calculated length is displayed in the **Present probe length** parameter → 181. This procedure has to be repeated until the displayed value matches the actual length of the probe.
- **Probe length too big**
To be selected if the displayed length is bigger than the actual length of the probe. A different end of probe signal is allocated and the newly calculated length is indicated in the **Present probe length** parameter → 181. This procedure has to be repeated until the displayed value matches the actual length of the probe.
- **Probe covered**
To be selected if the probe is (partially or completely) covered. A probe length correction is impossible in this case. The device quits the sequence.
- **Manual input**
To be selected if no automatic probe length correction is to be performed. Instead, the actual length of the probe must be entered manually into the **Present probe length** parameter → 181 ¹¹⁾.
- **Probe length unknown**
To be selected if the actual length of the probe is unknown. A probe length correction is impossible in this case and the device quits the sequence.

11) When operated via FieldCare, the **Manual input** option needs not to be selected explicitly. In FieldCare the length of the probe can always be edited.

"Probe length correction" wizard

 The **Probe length correction** wizard is only available when operating via the local display. When operating via an operating tool, all parameters concerning the probe length correction are located directly in the **Probe settings** submenu (→  181).

Navigation  Setup → Advanced setup → Probe settings → Prob.length corr

Confirm probe length

**Navigation**

 Setup → Advanced setup → Probe settings → Prob.length corr → Confirm length

Description

→  182

Present probe length



**Navigation**

 Setup → Advanced setup → Probe settings → Prob.length corr → Pres. length

Description

→  181

"Current output 1 to 2" submenu

 The **Current output 2** submenu (→  184) is only available for devices with two current outputs.

Navigation  Setup → Advanced setup → Curr.output 1 to 2

Assign current output 1 to 2 

Navigation  Setup → Advanced setup → Curr.output 1 to 2 → Assign curr.

Description Select process variable for current output.

- Selection**
- Level linearized
 - Distance
 - Electronic temperature
 - Relative echo amplitude
 - Analog output adv. diagnostics 1
 - Analog output adv. diagnostics 2



Additionally for Operating mode = "Interface" or "Interface with capacitance":

- Interface linearized
- Interface distance
- Thickness upper layer
- Relative interface amplitude

- Factory setting**
- For level measurements**
- Current output 1: Level linearized
 - Current output 2 ¹²⁾: Relative echo amplitude

- For interface measurements**
- Current output 1: Interface linearized
 - Current output 2 ¹³⁾: Level linearized

Additional information *Definition of the current range for the process variables*

Process variable	4 mA value	20 mA value
Level linearized	0 % ¹⁾ or the associated linearized value	100 % ²⁾ or the associated linearized value
Distance	0 (i.e. level is at the reference point)	Empty calibration (→  140) (i.e. level is at 0 %)
Electronic temperature	-50 °C (-58 °F)	100 °C (212 °F)
Relative echo amplitude	0 mV	2 000 mV
Analog output adv. diagnostics 1/2	depending on the parametrization of the Advanced Diagnostics	
Interface linearized	0 % ¹⁾ or the associated linearized value	100 % ²⁾ or the associated linearized value
Interface distance	0 (i.e. interface at the reference point)	Empty calibration (→  140) (i.e. interface is at 0 %)

12) only for devices with two current outputs
 13) only for devices with two current outputs

Process variable	4 mA value	20 mA value
Thickness upper layer	0 % ¹⁾ or the associated linearized value	100 % ²⁾ or the associated linearized value
Relative interface amplitude	0 mV	2 000 mV

- 1) the 0% level is defined by **Empty calibration** parameter (→ ⓘ 140)
- 2) The 100% level is defined by **Full calibration** parameter (→ ⓘ 141)

 It may be necessary to adjust the 4mA and 20mA values to the application (especially in the case of the **Analog output adv. diagnostics 1/2** option).

This can be done by the following parameters:

- Expert → Output → Curr.output 1 to 2 → Turn down
- Expert → Output → Curr.output 1 to 2 → 4 mA value
- Expert → Output → Curr.output 1 to 2 → 20 mA value

Current span

Navigation

 Setup → Advanced setup → Curr.output 1 to 2 → Current span

Description

Select current range for process variable and alarm signal.

Selection

- 4...20 mA
- 4...20 mA NAMUR
- 4...20 mA US
- Fixed current

Factory setting

4...20 mA NAMUR

Additional information

Meaning of the options

Option	Current range for process variable	Lower alarm signal level	Upper alarm signal level
4...20 mA	4 to 20.5 mA	< 3.6 mA	> 21.95 mA
4...20 mA NAMUR	3.8 to 20.5 mA	< 3.6 mA	> 21.95 mA
4...20 mA US	3.9 to 20.8 mA	< 3.6 mA	> 21.95 mA
Fixed current	Constant current, defined in the Fixed current parameter (→ ⓘ 186).		

-  In the case of an error, the output current assumes the value defined in the **Failure mode** parameter (→ ⓘ 186).
- If the measured value is out of the measuring range, diagnostic message **Current output** is issued.

 In a HART multidrop loop only one device can use the analog current to transmit a signal. For all other devices one must set:

- **Current span = Fixed current**
- **Fixed current (→ ⓘ 186) = 4 mA**

Fixed current





Navigation	Setup → Advanced setup → Curr.output 1 to 2 → Fixed current
Prerequisite	Current span (→ 185) = Fixed current
Description	Define constant value of the current.
User entry	4 to 22.5 mA
Factory setting	4 mA

Damping output



Navigation	Setup → Advanced setup → Curr.output 1 to 2 → Damping out.
Description	Define time constant τ for the damping of the output current.
User entry	0.0 to 999.9 s
Factory setting	0.0 s
Additional information	Fluctuations of the measured value affect the output current with an exponential delay, the time constant τ of which is defined in this parameter. With a small time constant the output reacts immediately to changes of the measured value. With a big time constant the reaction of the output is more delayed. For $\tau = 0$ (factory setting) there is no damping.

Failure mode



Navigation	Setup → Advanced setup → Curr.output 1 to 2 → Failure mode
Prerequisite	Current span (→ 185) ≠ Fixed current
Description	Select behavior of the output current in case of an error.
Selection	<ul style="list-style-type: none"> ■ Min. ■ Max. ■ Last valid value ■ Actual value ■ Defined value
Factory setting	Max.

Additional information	<p>Meaning of the options</p> <ul style="list-style-type: none"> ▪ Min. The current output adopts the value of the lower alarm level according to the Current span parameter (→  185). ▪ Max. The current output adopts the value of the upper alarm level according to the Current span parameter (→  185). ▪ Last valid value The current remains constant at the last value it had before the error occurred. ▪ Actual value The output current follows the actual measured value; the error is ignored. ▪ Defined value The output current assumes the value defined in the Failure current parameter (→  187). <p> The error behavior of other output channels is not influenced by these settings but is defined in separate parameters.</p>
-------------------------------	--

Failure current



Navigation	 Setup → Advanced setup → Curr.output 1 to 2 → Failure current
Prerequisite	Failure mode (→  186) = Defined value
Description	Enter current output value in alarm condition.
User entry	3.59 to 22.5 mA
Factory setting	22.5 mA







Output current 1 to 2

Navigation	 Setup → Advanced setup → Curr.output 1 to 2 → Output curr. 1 to 2
Description	Displays calculated output current.



"Switch output" submenu

Navigation  Setup → Advanced setup → Switch output

Switch output function 

Navigation	 Setup → Advanced setup → Switch output → Switch out funct
Description	Select function for switch output.
Selection	<ul style="list-style-type: none"> ▪ Off ▪ On ▪ Diagnostic behavior ▪ Limit ▪ Digital Output
Factory setting	Off
Additional information	<p>Meaning of the options</p> <ul style="list-style-type: none"> ▪ Off The output is always open (non-conductive). ▪ On The output is always closed (conductive). ▪ Diagnostic behavior The output is normally closed and is only opened if a diagnostic event is present. The Assign diagnostic behavior parameter (→  189) determines for which type of event the output is opened. ▪ Limit The output is normally closed and is only opened if a measured variable exceeds or falls below a defined limit. The limit values are defined by the following parameters: <ul style="list-style-type: none"> - Assign limit (→  189) - Switch-on value (→  190) - Switch-off value (→  191) ▪ Digital Output The switching state of the output tracks the output value of a DI function block. The function block is selected in the Assign status parameter (→  188). <p> The Off and On options can be used to simulate the switch output.</p>

Assign status 

Navigation	 Setup → Advanced setup → Switch output → Assign status
Prerequisite	Switch output function (→  188) = Digital Output
Description	Select device status for switch output.
Selection	<ul style="list-style-type: none"> ▪ Off ▪ Digital output AD 1 ▪ Digital output AD 2

Factory setting Off

Additional information The **Digital output AD 1** and **Digital output AD 2** options refer to the Advanced Diagnostic Blocks. A switch signal generated in these blocks can be transmitted via the switch output.

Assign limit

Navigation   Setup → Advanced setup → Switch output → Assign limit

Prerequisite **Switch output function** (→  188) = **Limit**

Description Select process variable for limit monitoring.

Selection

- Off
- Level linearized
- Distance
- Interface linearized *
- Interface distance *
- Thickness upper layer *
- Terminal voltage
- Electronic temperature
- Measured capacitance *
- Relative echo amplitude
- Relative interface amplitude *
- Absolute echo amplitude
- Absolute interface amplitude *

Factory setting Off

Assign diagnostic behavior

Navigation   Setup → Advanced setup → Switch output → Assign diag. beh

Prerequisite **Switch output function** (→  188) = **Diagnostic behavior**

Description Select diagnostic behavior for switch output.

Selection

- Alarm
- Alarm or warning
- Warning

Factory setting Alarm

* Visibility depends on order options or device settings

Switch-on value



Navigation

Setup → Advanced setup → Switch output → Switch-on value

Prerequisite

Switch output function (→ 188) = **Limit**

Description

Enter measured value for the switch-on point.

User entry

Signed floating-point number

Factory setting

0

Additional information

The switching behavior depends on the relative position of the **Switch-on value** and **Switch-off value** parameters:

Switch-on value > Switch-off value

- The output is closed if the measured value is larger than **Switch-on value**.
- The output is opened if the measured value is smaller than **Switch-off value**.

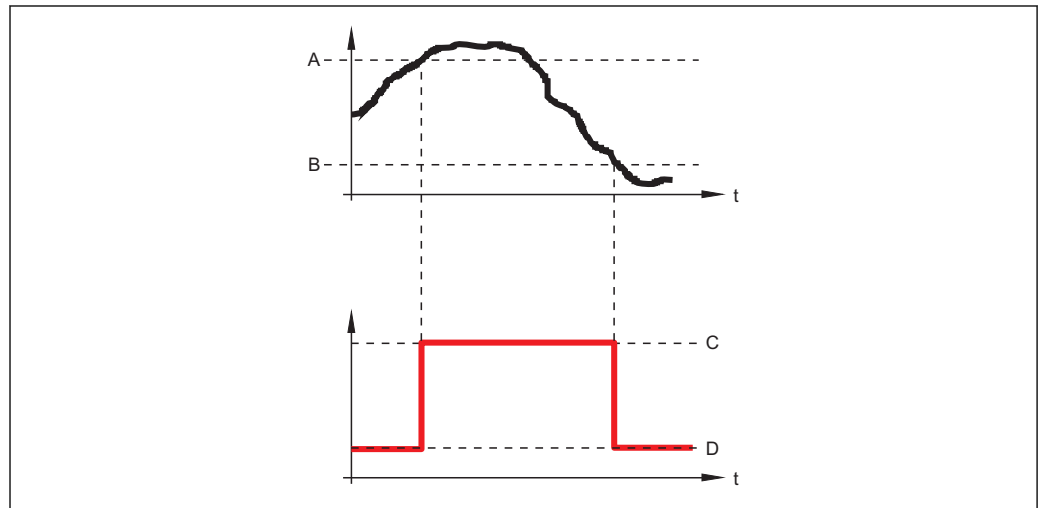

A0015585

- A *Switch-on value*
- B *Switch-off value*
- C *Output closed (conductive)*
- D *Output opened (non-conductive)*

Switch-on value < Switch-off value

- The output is closed if the measured value is smaller than **Switch-on value**.
- The output is opened if the measured value is larger than **Switch-off value**.

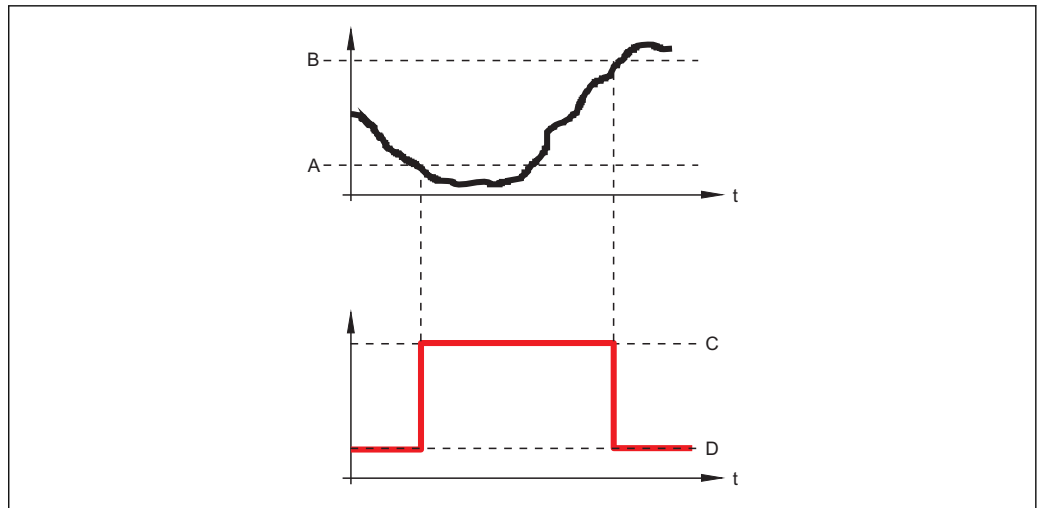

A0015586

- A Switch-on value
- B Switch-off value
- C Output closed (conductive)
- D Output opened (non-conductive)

Switch-on delay



Navigation	☰☰ Setup → Advanced setup → Switch output → Switch-on delay
Prerequisite	<ul style="list-style-type: none"> ▪ Switch output function (→ ☰ 188) = Limit ▪ Assign limit (→ ☰ 189) ≠ Off
Description	Define switch-on delay.
User entry	0.0 to 100.0 s
Factory setting	0.0 s





Switch-off value



Navigation	☰☰ Setup → Advanced setup → Switch output → Switch-off value
Prerequisite	Switch output function (→ ☰ 188) = Limit
Description	Enter measured value for the switch-off point.
User entry	Signed floating-point number
Factory setting	0
Additional information	The switching behavior depends on the relative position of the Switch-on value and Switch-off value parameters; description: see the Switch-on value parameter (→ ☰ 190).



Switch-off delay





Navigation	  Setup → Advanced setup → Switch output → Switch-off delay
Prerequisite	<ul style="list-style-type: none"> ▪ Switch output function (→  188) = Limit ▪ Assign limit (→  189) ≠ Off
Description	Define switch-off delay.
User entry	0.0 to 100.0 s
Factory setting	0.0 s

Failure mode





Navigation	  Setup → Advanced setup → Switch output → Failure mode
Description	Define output behavior in alarm condition.
Selection	<ul style="list-style-type: none"> ▪ Actual status ▪ Open ▪ Closed
Factory setting	Open

Switch status

Navigation	  Setup → Advanced setup → Switch output → Switch status
Description	Displays the current state of the switch output.

Invert output signal



Navigation	  Setup → Advanced setup → Switch output → Invert outp.sig.
Description	Specify whether the output signal is to be inverted.
Selection	<ul style="list-style-type: none"> ▪ No ▪ Yes
Factory setting	No

Additional information**Meaning of the options**

- **No**
The behavior of the switch output is as described above.
- **Yes**
The states **Open** and **Closed** are inverted as compared to the description above.

"Display" submenu

 The **Display** submenu is only visible if a display module is connected to the device.

Navigation  Setup → Advanced setup → Display

Language**Navigation**

 Setup → Advanced setup → Display → Language

Description

Set display language.

Selection

- English
- Deutsch *
- Français *
- Español *
- Italiano *
- Nederlands *
- Portuguesa *
- Polski *
- русский язык (Russian) *
- Svenska *
- Türkçe *
- 中文 (Chinese) *
- 日本語 (Japanese) *
- 한국어 (Korean) *
- Bahasa Indonesia *
- tiếng Việt (Vietnamese) *
- čeština (Czech) *

Factory setting

The language selected in feature 500 of the product structure.
If no language has been selected: **English**

Format display**Navigation**

 Setup → Advanced setup → Display → Format display

Description

Select how measured values are shown on the display.

Selection

- 1 value, max. size
- 1 bargraph + 1 value
- 2 values
- 1 value large + 2 values
- 4 values

Factory setting

1 value, max. size

* Visibility depends on order options or device settings

Additional information



A0019963

45 "Format display" = "1 value, max. size"

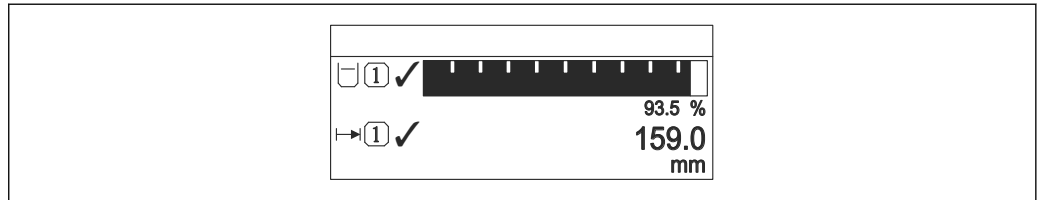

A0019964

46 "Format display" = "1 bargraph + 1 value"

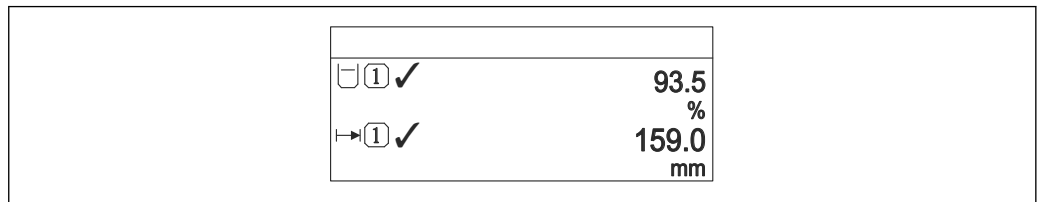

A0019965

47 "Format display" = "2 values"

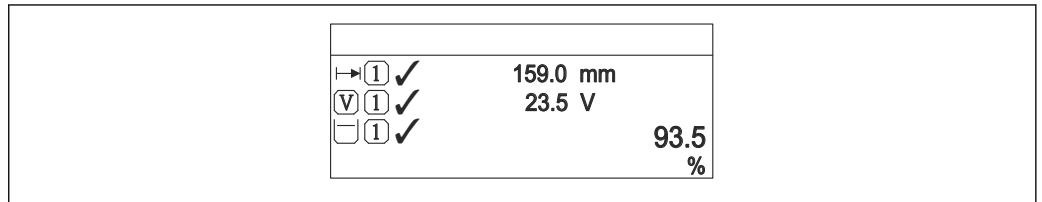

A0019966

48 "Format display" = "1 value large + 2 values"

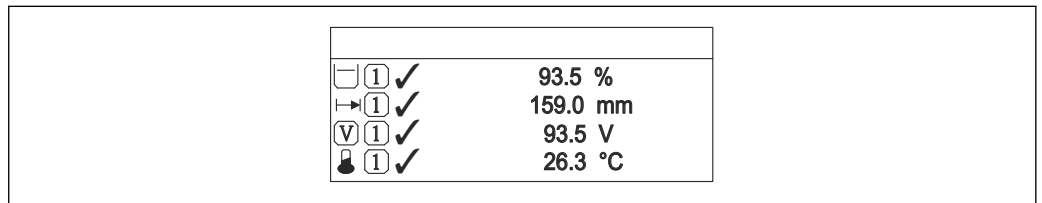

A0019968

49 "Format display" = "4 values"

- i
■
The Value 1 to 4 display → 196 parameters specify which measured values are shown on the display and in which order.
- If more measured values are specified than the current display mode permits, the values alternate on the device display. The display time until the next change is configured in the **Display interval** parameter (→ 197).

Value 1 to 4 display

Navigation	Setup → Advanced setup → Display → Value 1 display
Description	Select the measured value that is shown on the local display.
Selection	<ul style="list-style-type: none"> ■ None ¹⁴⁾ ■ Level linearized ■ Distance ■ Interface linearized ■ Interface distance ■ Thickness upper layer ■ Current output 1 ¹⁵⁾ ■ Measured current ■ Current output 2 ■ Terminal voltage ■ Electronic temperature ■ Analog output adv. diagnostics 1 ■ Analog output adv. diagnostics 2
Factory setting	<p>For level measurements</p> <ul style="list-style-type: none"> ■ Value 1 display: Level linearized ■ Value 2 display: Distance ■ Value 3 display: Current output 1 ■ Value 4 display: None <p>For interface measurements and one current output</p> <ul style="list-style-type: none"> ■ Value 1 display: Interface linearized ■ Value 2 display: Level linearized ■ Value 3 display: Thickness upper layer ■ Value 4 display: Current output 1 <p>For interface measurements and two current outputs</p> <ul style="list-style-type: none"> ■ Value 1 display: Interface linearized ■ Value 2 display: Level linearized ■ Value 3 display: Current output 1 ■ Value 4 display: Current output 2

Decimal places 1 to 4



Navigation	Setup → Advanced setup → Display → Decimal places 1
Description	Select the number of decimal places for the display value.
Selection	<ul style="list-style-type: none"> ■ x ■ x.x ■ x.xx ■ x.xxx ■ x.xxxx
Factory setting	x.xx

14) can not be selected for the 'Value 1 display' parameter.

15) Visibility depends on order options or device settings



Additional information The setting does not affect the measuring or computational accuracy of the device.

Display interval

Navigation	  Setup → Advanced setup → Display → Display interval
Description	Set time measured values are shown on display if display alternates between values.
User entry	1 to 10 s
Factory setting	5 s
Additional information	This parameter is only relevant if the number of selected measuring values exceeds the number of values the selected display format can display simultaneously.



Display damping



Navigation	  Setup → Advanced setup → Display → Display damping
Description	Define display reaction time to fluctuations in the measured value.
User entry	0.0 to 999.9 s
Factory setting	0.0 s

Header



Navigation	  Setup → Advanced setup → Display → Header
Description	Select header contents on local display.
Selection	<ul style="list-style-type: none"> ■ Device tag ■ Free text
Factory setting	Device tag

Additional information

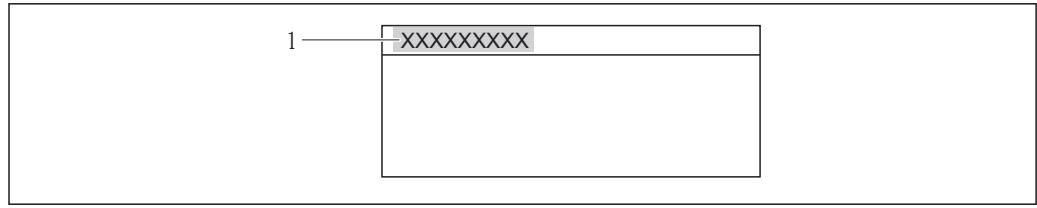

A0013375

1 Position of the header text on the display

Meaning of the options

- **Device tag**
Is defined in the **Device tag** parameter (→ 138).
- **Free text**
Is defined in the **Header text** parameter (→ 198).

Header text



Navigation Setup → Advanced setup → Display → Header text

Prerequisite **Header (→ 197) = Free text**

Description Enter display header text.

Factory setting -----

Additional information The number of characters which can be displayed depends on the characters used.

Separator



Navigation Setup → Advanced setup → Display → Separator

Description Select decimal separator for displaying numerical values.

Selection ■ .
 ■ ,

Factory setting .

Number format





Navigation Setup → Advanced setup → Display → Number format

Description Choose number format for the display.



Selection ■ Decimal
 ■ ft-in-1/16"

Factory setting	Decimal
Additional information	The ft-in-1/16" option is only valid for distance units.

Decimal places menu

Navigation	  Setup → Advanced setup → Display → Dec. places menu
Description	Select number of decimal places for the representation of numbers within the operating menu.
Selection	<ul style="list-style-type: none"> ■ x ■ x.x ■ x.xx ■ x.xxx ■ x.xxxx
Factory setting	x.xxxx
Additional information	<ul style="list-style-type: none"> ■ Is only valid for numbers in the operating menu (e.g. Empty calibration, Full calibration), but not for the measured value display. The number of decimal places for the measured value display is defined in the Decimal places 1 to 4 →  196 parameters. ■ The setting does not affect the accuracy of the measurement or the calculations.

Backlight

Navigation	  Setup → Advanced setup → Display → Backlight
Prerequisite	The device has the SD03 local display (with optical keys).
Description	Switch the local display backlight on and off.
Selection	<ul style="list-style-type: none"> ■ Disable ■ Enable
Factory setting	Disable
Additional information	<p>Meaning of the options</p> <ul style="list-style-type: none"> ■ Disable Switches the backlight off. ■ Enable Switches the backlight on. <p> Regardless of the setting in this parameter the backlight may be automatically switched off by the device if the supply voltage is too low.</p>

Contrast display

Navigation

 Setup → Advanced setup → Display → Contrast display

Description

Adjust local display contrast setting to ambient conditions (e.g. lighting or reading angle).





User entry

20 to 80 %

Factory setting

Dependent on the display.



Additional information



-  Setting the contrast via push-buttons:
- Darker: press the  and  buttons simultaneously.
 - Brighter: press the  and  buttons simultaneously.

"Configuration backup display" submenu



 This submenu is only visible if a display module is connected to the device.

The configuration of the device can be saved to the display module at a certain point of time (backup). The saved configuration can be restored to the device if required, e.g. in order to bring the device back into a defined state. The configuration can also be transferred to a different device of the same type using the display module.



 Configurations can only be exchanged between devices which are in the same operating mode (see the **Operating mode** parameter (→  138)).

Navigation   Setup → Advanced setup → Conf.backup disp

Operating time



Navigation	  Setup → Advanced setup → Conf.backup disp → Operating time
Description	Indicates how long the device has been in operation.
User interface	Days (d), hours (h), minutes (m), seconds (s)
Additional information	<i>Maximum time</i> 9 999 d (≈ 27 years)

Last backup

Navigation	  Setup → Advanced setup → Conf.backup disp → Last backup
Description	Indicates when the last data backup was saved to the display module.
User interface	Days (d), hours (h), minutes (m), seconds (s)

Configuration management



Navigation	  Setup → Advanced setup → Conf.backup disp → Config. managem.
Description	Select action for managing the device data in the display module.
Selection	<ul style="list-style-type: none"> ■ Cancel ■ Execute backup ■ Restore ■ Duplicate ■ Compare ■ Clear backup data
Factory setting	Cancel

Additional information**Meaning of the options**■ **Cancel**

No user is executed and the user exits the parameter.

■ **Execute backup**

A backup copy of the current device configuration in the HistoROM (built-in in the device) is saved to the display module of the device.

■ **Restore**

The last backup copy of the device configuration is copied from the display module to the HistoROM of the device.

■ **Duplicate**

The transmitter configuration is duplicated to another device using the transmitter display module. The following parameters, which characterize the individual measuring point are **not** included in the transmitted configuration:

- HART date code
- HART short tag
- HART message
- HART descriptor
- HART address
- Device tag
- Medium type

■ **Compare**

The device configuration saved in the display module is compared to the current device configuration of the HistoROM. The result of this comparison is displayed in the **Comparison result** parameter (→  202).

■ **Clear backup data**

The backup copy of the device configuration is deleted from the display module of the device.



While this action is in progress, the configuration cannot be edited via the local display and a message on the processing status appears on the display.





If an existing backup is restored to a different device using the **Restore** option, it may occur that some device functionalities are no longer available. In some cases even a device reset will not restore the original status.

In order to transmit a configuration to a different device, the **Duplicate** option should always be used.

Backup state

Navigation



  Setup → Advanced setup → Conf.backup disp → Backup state

Description

Displays which backup action is currently in progress.

Comparison result

Navigation

  Setup → Advanced setup → Conf.backup disp → Compar. result

Description

Displays the comparison result between the device and the display.

Additional information**Meaning of the display options****■ Settings identical**

The current device configuration of the HistoROM is identical to the backup copy in the display module.

■ Settings not identical

The current device configuration of the HistoROM is not identical to the backup copy in the display module.

■ No backup available

There is no backup copy of the device configuration of the HistoROM in the display module.

■ Backup settings corrupt

The current device configuration of the HistoROM is corrupt or not compatible with the backup copy in the display module.

■ Check not done

The device configuration of the HistoROM has not yet been compared to the backup copy in the display module.

■ Dataset incompatible

The data sets are incompatible and can not be compared.





To start the comparison, set **Configuration management** (→  201) = **Compare**.













If the transmitter configuration has been duplicated from a different device by **Configuration management** (→  201) = **Duplicate**, the new device configuration in the HistoROM is only partially identical to the configuration stored in the display module: Sensor specific properties (e.g. the mapping curve) are not duplicated. Thus, the result of the comparison will be **Settings not identical**.



"Administration" submenu

Navigation  Setup → Advanced setup → Administration

Define access code 

Navigation	 Setup → Advanced setup → Administration → Def. access code
Description	Define release code for write access to parameters.
User entry	0 to 9999
Factory setting	0
Additional information	<p> If the factory setting is not changed or 0 is defined as the access code, the parameters are not write-protected and the configuration data of the device can then always be modified. The user is logged on in the <i>Maintenance</i> role.</p> <p> The write protection affects all parameters marked with the  symbol in this document. On the local display, the  symbol in front of a parameter indicates that the parameter is write-protected.</p> <p> Once the access code has been defined, write-protected parameters can only be modified if the access code is entered in the Enter access code parameter (→  153).</p> <p> Please contact your Endress+Hauser Sales Center if you lose your access code.</p> <p> For display operation: The new access code is only valid after it has been confirmed in the Confirm access code parameter (→  206).</p>

Device reset 

Navigation	  Setup → Advanced setup → Administration → Device reset
Description	Select to which state the device is to be reset.
Selection	<ul style="list-style-type: none"> ▪ Cancel ▪ To factory defaults ▪ To delivery settings ▪ Of customer settings ▪ To transducer defaults ▪ Restart device
Factory setting	Cancel

Additional information**Meaning of the options****■ Cancel**

No action

■ To factory defaults

All parameters are reset to the order-code specific factory setting.

■ To delivery settings

All parameters are reset to the delivery setting. The delivery setting may differ from the factory default if customer specific settings have been ordered.

This option is only visible if customer specific settings have been ordered.

■ Of customer settings

All customer parameters are reset to their factory setting. Service parameters, however, remain unchanged.

■ To transducer defaults

Every measurement-related parameter is reset to its factory setting. Service parameters and communication-related parameters, however, remain unchanged.

■ Restart device

The restart resets every parameter which is stored in the volatile memory (RAM) to the factory setting (e.g. measured value data). The device configuration remains unchanged.

"Define access code" wizard

 The **Define access code** wizard is only available when operating via the local display. When operating via an operating tool, the **Define access code** parameter is located directly in the **Administration** submenu. The **Confirm access code** parameter is not available for operation via operating tool.

Navigation  Setup → Advanced setup → Administration → Def. access code

Define access code 

Navigation  Setup → Advanced setup → Administration → Def. access code → Def. access code

Description →  204

Confirm access code 

Navigation  Setup → Advanced setup → Administration → Def. access code → Confirm code

Description Confirm the entered access code.

User entry 0 to 9999

Factory setting 0

16.4 "Diagnostics" menu

Navigation   Diagnostics

Actual diagnostics



Navigation   Diagnostics → Actual diagnos.

Description Displays current diagnostic message.

Additional information The display consists of:

- Symbol for event behavior
- Code for diagnostic behavior
- Operating time of occurrence
- Event text

 If several messages are active at the same time, the messages with the highest priority is displayed.

 Information on what is causing the message, and remedy measures, can be viewed via the  symbol on the display.

Timestamp

Navigation  Diagnostics → Timestamp

Description Displays timestamp for the **Actual diagnostics** parameter (→  207).

User interface Days (d), hours (h), minutes (m), seconds (s)



Previous diagnostics

Navigation   Diagnostics → Prev.diagnostics



Description Displays the last diagnostic message which has been active before the current message.

Additional information The display consists of:



- Symbol for event behavior
- Code for diagnostic behavior
- Operating time of occurrence
- Event text

 The condition displayed may still apply. Information on what is causing the message, and remedy measures, can be viewed via the  symbol on the display.



Timestamp

Navigation	 Diagnostics → Timestamp
Description	Displays timestamp for the Previous diagnostics parameter (→  207).
User interface	Days (d), hours (h), minutes (m), seconds (s)

Operating time from restart

Navigation	  Diagnostics → Time fr. restart
Description	Displays the time the device has been in operation since the last device restart.
User interface	Days (d), hours (h), minutes (m), seconds (s)



Operating time

Navigation	  Diagnostics → Operating time
Description	Indicates how long the device has been in operation.
User interface	Days (d), hours (h), minutes (m), seconds (s)
Additional information	<i>Maximum time</i> 9999 d (≈ 27 years)



16.4.1 "Diagnostic list" submenu

Navigation   Diagnostics → Diagnostic list

Diagnostics 1 to 5

Navigation	  Diagnostics → Diagnostic list → Diagnostics 1 to 5
Description	Display the current diagnostics messages with the highest to fifth-highest priority.
Additional information	The display consists of: <ul style="list-style-type: none">■ Symbol for event behavior■ Code for diagnostic behavior■ Operating time of occurrence■ Event text

Timestamp 1 to 5



Navigation	 Diagnostics → Diagnostic list → Timestamp
Description	Displays timestamp for the Diagnostics 1 to 5 parameter (→  209).
User interface	Days (d), hours (h), minutes (m), seconds (s)

16.4.2 "Event logbook" submenu

 The **Event logbook** submenu is only available when operating via the local display. When operating via FieldCare, the event list can be displayed in the FieldCare function "Event List / HistoROM".

Navigation  Diagnostics → Event logbook



Filter options



Navigation	 Diagnostics → Event logbook → Filter options
Description	Select category (status signal) whose event messages are displayed in the events list.
Selection	<ul style="list-style-type: none"> ▪ All ▪ Failure (F) ▪ Function check (C) ▪ Out of specification (S) ▪ Maintenance required (M) ▪ Information (I)
Factory setting	All
Additional information	 <ul style="list-style-type: none"> ▪ This parameter is only used for operation via the local display. ▪ The status signals are categorized according to NAMUR NE 107.

"Event list" submenu

The **Event list** submenu displays the history of past events of the category selected in the **Filter options** parameter (→  210). A maximum of 100 events are displayed in chronological order.

The following symbols indicate whether an event has occurred or has ended:

- : Event has occurred
- : Event has ended

 Information on what is causing the message, and remedy instructions, can be viewed via the -button.

Display format

- For event messages in category I: information event, event text, "recording event" symbol and time the event occurred
- For event messages in category F, M, C, S (status signal): diagnostics event, event text, "recording event" symbol and time the event occurred

Navigation  Diagnostics → Event logbook → Event list

16.4.3 "Device information" submenu

Navigation   Diagnostics → Device info

Device tag

Navigation   Diagnostics → Device info → Device tag

Description Enter the name for the measuring point.

Factory setting FMP5x

Serial number

Navigation   Diagnostics → Device info → Serial number

Description Displays serial number of the device.

Additional information  **Uses of the serial number**

- To identify the device quickly, e.g. when contacting Endress+Hauser.
- To obtain specific information on the device using the Device Viewer:
www.endress.com/deviceviewer

 The serial number is also indicated on the nameplate.

Firmware version

Navigation   Diagnostics → Device info → Firmware version

Description Indicates the installed Firmware version.

User interface xx.yy.zz



Additional information  For firmware versions differing only in the last two digits ("zz") there is no difference concerning functionality or operation.

Device name

Navigation   Diagnostics → Device info → Device name

Description Displays device name.



Order code

Navigation   Diagnostics → Device info → Order code

Description Displays order code of the device.

Additional information The order code is generated from the extended order code, which defines all device features of the product structure. In contrast, the device features can not be read directly from the order code.



Extended order code 1 to 3

Navigation   Diagnostics → Device info → Ext. order cd. 1 to 3

Description Displays the three parts of the extended order code.

Additional information The extended order code indicates the version of all the features of the product structure and thus uniquely identifies the device.

Device revision

Navigation   Diagnostics → Device info → Device revision

Description Displays the device revision registered for this device at the HART Communication Foundation.

Additional information The device revision is used to allocate the correct Device Description file (DD) to the device.

Device ID

Navigation   Diagnostics → Device info → Device ID

Description Displays Device ID.

Additional information In addition to the Device type and Manufacturer ID, the Device ID is part of the unique device identification (Unique ID) which characterizes each HART device unambiguously.

Device type

Navigation Diagnostics → Device info → Device type**Description**

Displays the device type with which the device is registered with the the HART Communication Foundation.

Additional information

The device type is needed to allocate the correct Device Description file (DD) to the device.

Manufacturer ID

Navigation Diagnostics → Device info → Manufacturer ID**Description**

Displays the manufactured ID with which the device is registered with the HART Communication Foundation.

16.4.4 "Measured values" submenu

Navigation  Diagnostics → Measured val.

Distance

Navigation

 Diagnostics → Measured val. → Distance

Description

Displays the measured distance D_L between the reference point (lower edge of the flange or threaded connection) and the level.

Additional information

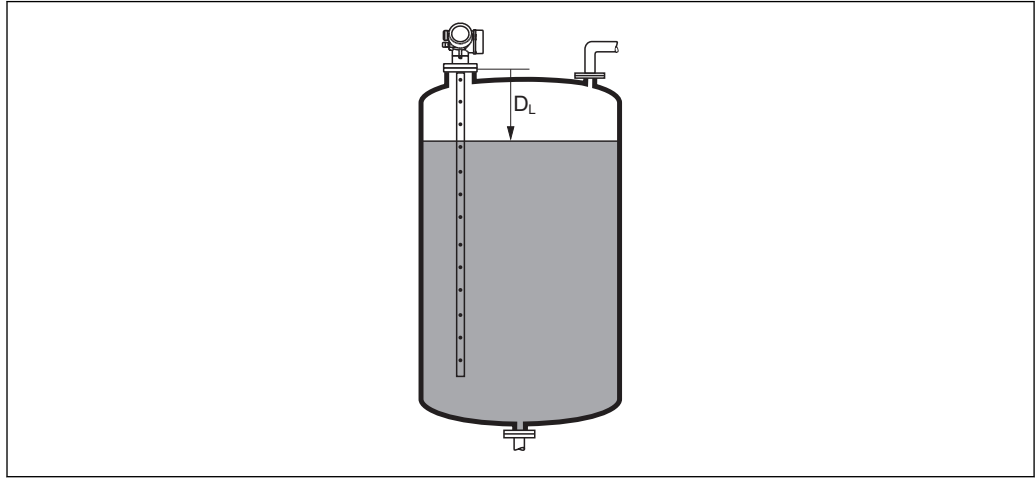

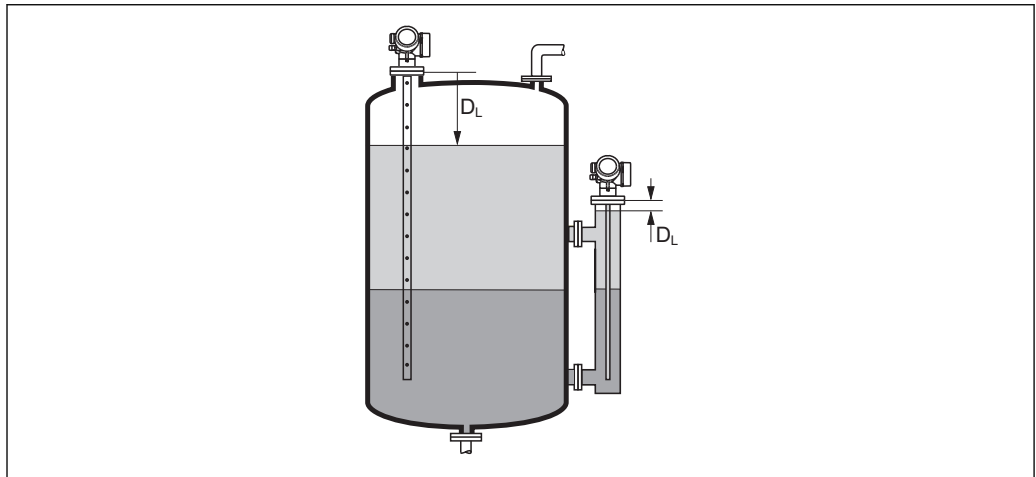

A0013198

 50 Distance for liquid measurements





A0013199



 51 Distance for interface measurements

 The unit is defined in the **Distance unit** parameter (→  138).

Level linearized

Navigation	 Diagnostics → Measured val. → Level linearized
Description	Displays linearized level.
Additional information	 <ul style="list-style-type: none"> ▪ The unit is defined by the Unit after linearization parameter →  169. ▪ For interface measurements, this parameter always refers to the total level.

Interface distance



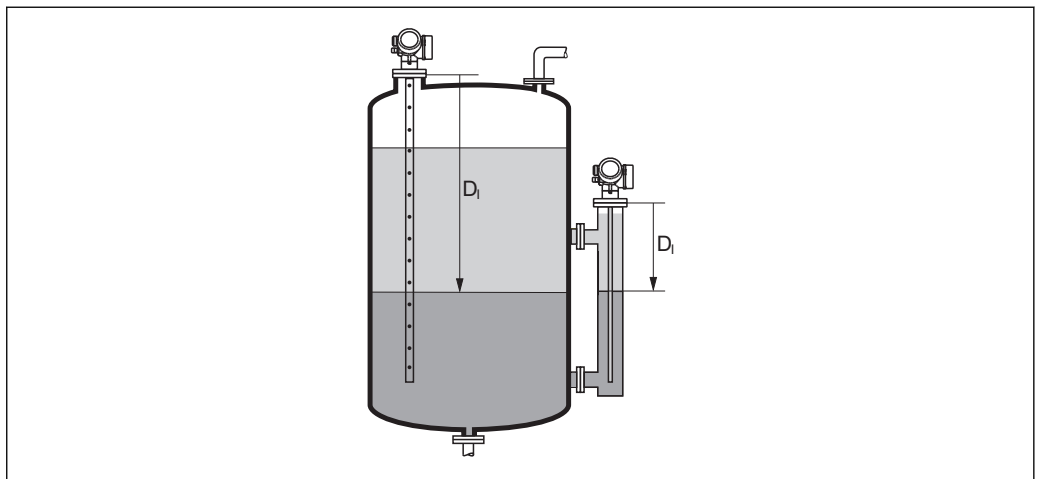

Navigation	 Diagnostics → Measured val. → Interface dist.
Prerequisite	Operating mode (→  138) = Interface or Interface with capacitance
Description	Displays the measured distance D_1 between the reference point (lower edge of flange or threaded connection) and the interface.
Additional information	





A0013202

 The unit is defined in the **Distance unit** parameter (→  138).

Interface linearized

Navigation	 Diagnostics → Measured val. → Interf. lineariz
Prerequisite	Operating mode (→  138) = Interface or Interface with capacitance
Description	Displays the linearized interface height.
Additional information	 The unit is defined in the Unit after linearization parameter →  169.

Thickness upper layer

Navigation
  Diagnostics → Measured val. → Thickn.upper.layer
Prerequisite
Operating mode (→  138) = **Interface** or **Interface with capacitance**
Description

Displays the upper interface thickness (UP).

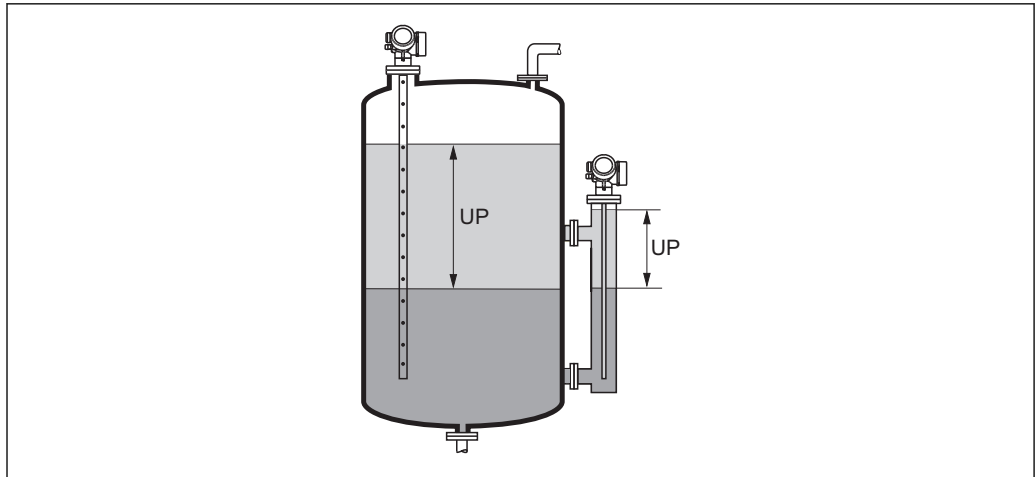
Additional information

A0013313

UP Thickness upper layer

 The unit is defined by the **Unit after linearization** parameter →  169.

Output current 1 to 2

Navigation
  Diagnostics → Measured val. → Output curr. 1 to 2
Description

Displays calculated output current.

Measured current 1

Navigation
  Diagnostics → Measured val. → Measur. curr. 1
Prerequisite

Only available for current output 1

Description

Displays the measured value of the output current.

Terminal voltage 1



Navigation Diagnostics → Measured val. → Terminal volt. 1**Description**

Displays terminal voltage at the current output.

16.4.5 "Data logging" submenu

Navigation  Diagnostics → Data logging

Assign channel 1 to 4

Navigation	 Diagnostics → Data logging → Assign chan. 1 to 4
Description	Allocate a process variable to the respective data logging channel.
Selection	<ul style="list-style-type: none"> ■ Off ■ Level linearized ■ Distance ■ Unfiltered distance ■ Interface linearized[*] ■ Interface distance[*] ■ Unfiltered interface distance ■ Thickness upper layer[*] ■ Current output 1 ■ Measured current ■ Current output 2[*] ■ Terminal voltage ■ Electronic temperature ■ Measured capacitance[*] ■ Absolute echo amplitude ■ Relative echo amplitude ■ Absolute interface amplitude[*] ■ Relative interface amplitude[*] ■ Absolute EOP amplitude ■ EOP shift ■ Noise of signal ■ Calculated DC value[*] ■ Analog output adv. diagnostics 1 ■ Analog output adv. diagnostics 2
Factory setting	Off
Additional information	<p>A total of 1000 measured values can be logged. This means:</p> <ul style="list-style-type: none"> ■ 1000 data points if 1 logging channel is used ■ 500 data points if 2 logging channels are used ■ 333 data points if 3 logging channels are used ■ 250 data points if 4 logging channels are used <p>If the maximum number of data points is reached, the oldest data points in the data log are cyclically overwritten in such a way that the last 1000, 500, 333 or 250 measured values are always in the log (ring memory principle).</p> <p> The logged data are deleted if a new option is selected in this parameter.</p>

* Visibility depends on order options or device settings

Logging interval

Navigation	Diagnostics → Data logging → Logging interval
Description	Define logging interval t_{\log} .
User entry	1.0 to 3 600.0 s
Factory setting	30.0 s
Additional information	<p>This parameter defines the interval between the individual data points in the data log, and thus the maximum loggable process time T_{\log}:</p> <ul style="list-style-type: none"> ■ If 1 logging channel is used: $T_{\log} = 1000 \cdot t_{\log}$ ■ If 2 logging channels are used: $T_{\log} = 500 \cdot t_{\log}$ ■ If 3 logging channels are used: $T_{\log} = 333 \cdot t_{\log}$ ■ If 4 logging channels are used: $T_{\log} = 250 \cdot t_{\log}$ <p>Once this time elapses, the oldest data points in the data log are cyclically overwritten such that a time of T_{\log} always remains in the memory (ring memory principle).</p> <p> The logged data are deleted if this parameter is changed.</p>

*Example***When using 1 logging channel**

- $T_{\log} = 1000 \cdot 1 \text{ s} = 1000 \text{ s} \approx 16.5 \text{ min}$
- $T_{\log} = 1000 \cdot 10 \text{ s} = 1000 \text{ s} \approx 2.75 \text{ h}$
- $T_{\log} = 1000 \cdot 80 \text{ s} = 80000 \text{ s} \approx 22 \text{ h}$
- $T_{\log} = 1000 \cdot 3600 \text{ s} = 3600000 \text{ s} \approx 41 \text{ d}$

Clear logging data

Navigation	Diagnostics → Data logging → Clear logging
Description	Initiate a deletion of the complete logging memory.
Selection	<ul style="list-style-type: none"> ■ Cancel ■ Clear data
Factory setting	Cancel

"Display channel 1 to 4" submenu

i The **Display channel 1 to 4** submenus are only available for operation via the local display. When operating via FieldCare, the logging diagram can be displayed in the FieldCare function "Event List / HistoROM" .

The **Display channel 1 to 4** submenus invoke a diagram of the logging history of the respective channel.

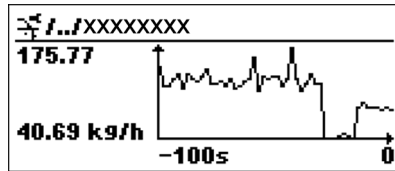

- x-axis: depending on the number of selected channels, 250 to 1000 measured values of a process variable are displayed.
- y-axis: covers the approximate measured value span and constantly adapts this to the measurement.









i To return to the operating menu, press \oplus and \ominus simultaneously.

Navigation ☰ ☰ Diagnostics → Data logging → Displ.channel 1 to 4

16.4.6 "Simulation" submenu









The **Simulation** submenu is used to simulate specific measuring values or other conditions. This helps to check the correct configuration of the device and connected control units.

Conditions which can be simulated

Condition to be simulated	Associated parameters
Specific value of a process variable	<ul style="list-style-type: none"> ▪ Assign measurement variable (→  223) ▪ Process variable value (→  223)
Specific value of the output current	<ul style="list-style-type: none"> ▪ Current output simulation (→  224) ▪ Value current output (→  224)
Specific state of the switch output	<ul style="list-style-type: none"> ▪ Switch output simulation (→  224) ▪ Switch status (→  225)
Existence of an alarm	Device alarm simulation (→  225)
Existence of a specific diagnostic message	Diagnostic event simulation (→  225)

Structure of the submenu



Navigation  Expert → Diagnostics → Simulation

▶ Simulation	
Assign measurement variable	→  223
Process variable value	→  223
Current output 1 to 2 simulation	→  224
Value current output 1 to 2	→  224
Switch output simulation	→  224
Switch status	→  225
Device alarm simulation	→  225
Diagnostic event simulation	→  225



Description of parameters

Navigation  Expert → Diagnostics → Simulation

Assign measurement variable

Navigation	 Expert → Diagnostics → Simulation → Assign meas.var.
Description	Select process variable to be simulated.
Selection	<ul style="list-style-type: none"> ■ Off ■ Level ■ Interface * ■ Thickness upper layer * ■ Level linearized ■ Interface linearized ■ Thickness linearized
Factory setting	Off
Additional information	<ul style="list-style-type: none"> ■ The value of the variable to be simulated is defined in the Process variable value parameter (→  223). ■ If Assign measurement variable ≠ Off, a simulation is active. This is indicated by a diagnostic message of the <i>Function check (C)</i> category.

Process variable value

Navigation	 Expert → Diagnostics → Simulation → Proc. var. value
Prerequisite	Assign measurement variable (→  223) ≠ Off
Description	Specify value of the process value being simulated.
User entry	Signed floating-point number
Factory setting	0
Additional information	Downstream measured value processing and the signal output use this simulation value. In this way, users can verify whether the measuring device has been configured correctly.

* Visibility depends on order options or device settings

Current output 1 to 2 simulation

Navigation	Expert → Diagnostics → Simulation → Curr.out. 1 to 2 sim.
Description	Switch the simulation of the current output on or off.
Selection	<ul style="list-style-type: none"> ■ Off ■ On
Factory setting	Off
Additional information	An active simulation is indicated by a diagnostic message of the <i>Function check (C)</i> category.

Value current output 1 to 2

Navigation	Expert → Diagnostics → Simulation → Value curr.out 1 to 2
Prerequisite	Current output simulation (→ 224) = On
Description	Enter current value for the simulation
User entry	3.59 to 22.5 mA
Factory setting	3.59 mA
Additional information	The current output assumes the value specified in this parameter. In this way, users can verify the correct adjustment of the current output and the correct function of connected control units.

Switch output simulation

Navigation	Expert → Diagnostics → Simulation → Switch sim.
Description	Switch the simulation of the switch output on or off.
Selection	<ul style="list-style-type: none"> ■ Off ■ On
Factory setting	Off

Switch status

Navigation	Expert → Diagnostics → Simulation → Switch status
Prerequisite	Switch output simulation (→ 224) = On
Description	Define the switch state to be simulated.
Selection	<ul style="list-style-type: none"> ■ Open ■ Closed
Factory setting	Open
Additional information	The switch status assumes the value defined in this parameter. This helps to check correct operation of connected control units.

Device alarm simulation

Navigation	Expert → Diagnostics → Simulation → Dev. alarm sim.
Description	Switch alarm simulation on or off.
Selection	<ul style="list-style-type: none"> ■ Off ■ On
Factory setting	Off
Additional information	<p>When selecting the On option, the device generates an alarm. This helps to check the correct output behavior of the device in the case of an alarm.</p> <p>An active simulation is indicated by the diagnostic message ⊗C484 Failure mode simulation.</p>

Diagnostic event simulation

Navigation	Expert → Diagnostics → Simulation → Diag. event sim.
Prerequisite	Access status display (→ 153)/ Access status tooling (→ 152) = Service
Description	Select diagnostic event to be simulated.
Factory setting	Off
Additional information	When operated via the local display, the selection list can be filtered according to the event categories (Diagnostic event category parameter).

16.4.7 "Device check" submenu

Navigation  Diagnostics → Device check

Start device check

Navigation	 Diagnostics → Device check → Start dev. check
Description	Start a device check.
Selection	<ul style="list-style-type: none"> ■ No ■ Yes
Factory setting	No
Additional information	In the case of a lost echo a device check can not be performed.



Result device check

Navigation	 Diagnostics → Device check → Result dev.check
Description	Displays the result of the device check.
Additional information	<p>Meaning of the display options</p> <ul style="list-style-type: none"> ■ Installation ok Measurement possible without restrictions. ■ Accuracy reduced A measurement is possible. However, the measuring accuracy may be reduced due to the signal amplitudes. ■ Measurement capability reduced A measurement is currently possible. However, there is the risk of an echo loss. Check the mounting position of the device and the dielectric constant of the medium. ■ Check not done No device check has been performed.



Last check time

Navigation	 Diagnostics → Device check → Last check time
Description	Displays the operating time at which the last device check has been performed.



Level signal

Navigation	  Diagnostics → Device check → Level signal
Prerequisite	Device check has been performed.
Description	Displays result of the device check for the level signal.
User interface	<ul style="list-style-type: none"> ■ Check not done ■ Check not OK ■ Check OK
Additional information	For Level signal = Check not OK : Check the mounting position of the device and the dielectric constant of the medium.

Launch signal

Navigation	  Diagnostics → Device check → Launch signal
Prerequisite	Device check has been performed.
Description	Displays result of the display check for the launch signal.
User interface	<ul style="list-style-type: none"> ■ Check not done ■ Check not OK ■ Check OK
Additional information	For Launch signal = Check not OK : Check the mounting position of the device. In non-metallic vessels use a metal plate or a metal flange.

Interface signal

Navigation	  Diagnostics → Device check → Interface signal
Prerequisite	<ul style="list-style-type: none"> ■ Operating mode (→  138) = Interface or Interface with capacitance ■ Device check has been performed.
Description	Displays result of the device check for the interface signal.
User interface	<ul style="list-style-type: none"> ■ Check not done ■ Check not OK ■ Check OK

Index

A

Access authorization to parameters	
Read access	71
Write access	71
Access code	71
Incorrect input	71
Access status display (Parameter)	153
Access status tooling (Parameter)	152
Accessories	
Communication specific	121
Device specific	113
Service specific	122
Activate table (Parameter)	174
Actual diagnostics (Parameter)	207
Administration (Submenu)	204
Advanced process conditions (Parameter)	156
Advanced setup (Submenu)	152
Application	13
Residual risk	13
Assign channel 1 to 4 (Parameter)	218
Assign current output (Parameter)	184
Assign diagnostic behavior (Parameter)	189
Assign limit (Parameter)	189
Assign measurement variable (Parameter)	223
Assign status (Parameter)	188
Automatic DC calculation (Wizard)	164

B

Backlight (Parameter)	199
Backup state (Parameter)	202
Blocking distance (Parameter)	157, 160, 177
Bypass	36

C

Calculated DC value (Parameter)	162
CE mark	14
Cleaning	110
Clear logging data (Parameter)	219
Coax probe	
Design	15
Coax probes	
Bending strength	26
Shortening	48
Code incorrect (Parameter)	180
Comparison result (Parameter)	202
Configuration backup display (Submenu)	201
Configuration management (Parameter)	201
Configuration of a level measurement	89
Configuration of an interface measurement	91
Confirm access code (Parameter)	206
Confirm distance (Parameter)	148, 151
Confirm probe length (Parameter)	182, 183
Context menu	83
Contrast display (Parameter)	200
Current output 1 to 2 (Submenu)	184
Current output 1 to 2 simulation (Parameter)	224

Current span (Parameter)	185
Customer value (Parameter)	174

D

Damping output (Parameter)	186
Data logging (Submenu)	218
DC value (Parameter)	146, 162, 164
DC value lower medium (Parameter)	159
DD	85
Deactivate SIL/WHG (Wizard)	180
Decimal places 1 (Parameter)	196
Decimal places menu (Parameter)	199
Declaration of Conformity	14
Define access code	72
Define access code (Parameter)	204, 206
Define access code (Wizard)	206
Designated use	13
Device alarm simulation (Parameter)	225
Device check (Submenu)	226
Device Descriptions	85
Device ID (Parameter)	212
Device information (Submenu)	211
Device name (Parameter)	211
Device replacement	111
Device reset (Parameter)	204
Device revision (Parameter)	212
Device tag (Parameter)	138, 211
Device type (Parameter)	213
Diagnostic event	
In the operating tool	104
Diagnostic event simulation (Parameter)	225
Diagnostic events	101
Diagnostic list	104
Diagnostic list (Submenu)	209
Diagnostic message	101
Diagnostics	
Symbols	101
Diagnostics (Menu)	207
Diagnostics 1 to 5 (Parameter)	209
Diagnostics event	102
Diameter (Parameter)	171
DIP switch	
see Write protection switch	
Display (Submenu)	194
Display and operating module FHX50	68
Display channel 1 to 4 (Submenu)	220
Display damping (Parameter)	197
Display interval (Parameter)	197
Display module	77
Display symbols for submenus	78
Display symbols for the locking state	78
Disposal	112
Distance (Parameter)	143, 151, 214
Distance to upper connection (Parameter)	146
Distance unit (Parameter)	138

- Document
 Function 5
Document function 5
- E**
- Electrical connection
 Commubox FXA291 69
 Operating tools
 Via service interface (CDI) 69
- Electronics housing
 Design 16
 Turning
 see Turning the transmitter housing
- Empty calibration (Parameter) 140
Enter access code (Parameter) 153
Envelope curve display 84
Event history 107
Event level
 Explanation 101
 Symbols 101
Event list (Submenu) 210
Event logbook (Submenu) 210
Event text 102
Events list 107
Extended order code 1 to 3 (Parameter) 212
Exterior cleaning 110
External mounting 42
- F**
- Failure current (Parameter) 187
Failure mode (Parameter) 186, 192
FHX50 68
Filter options (Parameter) 210
Filtering the event logbook 107
Firmware version (Parameter) 211
Fixed current (Parameter) 186
Flange 50
Format display (Parameter) 194
Free text (Parameter) 170
Full calibration (Parameter) 141
FV (HART device variable) 85
- G**
- Gas phasen compensation
 Mounting the probe rod 49
- H**
- Hardware write protection 74
HART device variables 85
HART loop converter HMX50 61
HART protocol 69
HART-Integration 85
Header (Parameter) 197
Header text (Parameter) 198
Heat insulation 44
HMX50 61
Housing
 Design 16
- I**
- Input mask 81
Interface (Parameter) 147
Interface (Submenu) 159
Interface distance (Parameter) 148, 215
Interface linearized (Parameter) 171, 215
Interface measurement configuration 91
Interface signal (Parameter) 227
Intermediate height (Parameter) 172
Invert output signal (Parameter) 192
- K**
- Keypad lock
 Disabling 76
 Switch-on 76
- L**
- Language (Parameter) 194
Last backup (Parameter) 201
Last check time (Parameter) 226
Launch signal (Parameter) 227
Level (Parameter) 142, 174
Level (Submenu) 154
Level correction (Parameter) 158, 161
Level linearized (Parameter) 170, 215
Level measurement configuration 89
Level signal (Parameter) 227
Level unit (Parameter) 157, 160
Linearization (Submenu) 166, 167, 168
Linearization type (Parameter) 168
Local display 68
 see Diagnostics message
 see In alarm condition
Locking status (Parameter) 152
Logging interval (Parameter) 219
- M**
- Maintenance 110
Manage device configuration 96
Manual thickness upper layer (Parameter) 161, 164
Manufacturer ID (Parameter) 213
Mapping (Wizard) 151
Mapping end point (Parameter) 150, 151
Maximum value (Parameter) 171
Measured current 1 (Parameter) 216
Measured materials 13
Measured thickness upper layer (Parameter) 162
Measured value symbols 79
Measured values (Submenu) 214
Medium group (Parameter) 140
Medium property (Parameter) 154
Medium type (Parameter) 154
Menu
 Diagnostics 207
 Setup 138
Mounting position for level measurements 21
- N**
- Non-metallic vessels 41

- Number format (Parameter) 198
- O**
- Operating elements
- Diagnostics message 102
- Operating mode (Parameter) 138
- Operating module 77
- Operating time (Parameter) 201, 208
- Operating time from restart (Parameter) 208
- Operational safety 14
- Order code (Parameter) 212
- Output current 1 to 2 (Parameter) 187, 216
- Output echo lost (Parameter) 176
- Overvoltage protection
- General information 65
- P**
- Present mapping (Parameter) 149
- Present probe length (Parameter) 181, 183
- Previous diagnostics (Parameter) 207
- Probe grounded (Parameter) 181
- Probe length correction (Wizard) 183
- Probe settings (Submenu) 181
- Process property (Parameter) 155, 159
- Process variable value (Parameter) 223
- Product safety 14
- PV (HART device variable) 85
- R**
- Ramp at echo lost (Parameter) 177
- Read access 71
- Record map (Parameter) 150, 151
- Registered trademarks 17
- Remedial measures
- Calling up 103
 - Closing 103
- Remote operation 69
- Repair concept 111
- Replacing a device 111
- Requirements for personnel 13
- Reset write protection (Parameter) 180
- Result device check (Parameter) 226
- Return 112
- Rod probe
- Design 15
- Rod probes
- Bending strength 25
 - Shortening 47
- Rope probe
- Design 15
- Rope probes
- Shortening 47
 - Tensile load 25
- S**
- Safety instructions
- Basic 13
- Safety Instructions (XA) 9
- Safety settings (Submenu) 176
- Securing coax probes 35
- Securing rod probes 34
- Securing rope probes 33
- Seilsonden
- Montage 50
- Separator (Parameter) 198
- Serial number (Parameter) 211
- Setting the operating language 87
- Settings
- Manage device configuration 96
 - Operating language 87
- Setup (Menu) 138
- Signal quality (Parameter) 144
- SIL/WHG confirmation (Wizard) 179
- Simulation (Submenu) 222, 223
- Spare parts 112
- Nameplate 112
- Start device check (Parameter) 226
- Status signals 78, 101
- Stilling well 36
- Submenu
- Administration 204
 - Advanced setup 152
 - Configuration backup display 201
 - Current output 1 to 2 184
 - Data logging 218
 - Device check 226
 - Device information 211
 - Diagnostic list 209
 - Display 194
 - Display channel 1 to 4 220
 - Event list 210
 - Event logbook 210
 - Events list 107
 - Interface 159
 - Level 154
 - Linearization 166, 167, 168
 - Measured values 214
 - Probe settings 181
 - Safety settings 176
 - Simulation 222, 223
 - Switch output 188
- SV (HART device variable) 85
- Switch output (Submenu) 188
- Switch output function (Parameter) 188
- Switch output simulation (Parameter) 224
- Switch status (Parameter) 192, 225
- Switch-off delay (Parameter) 192
- Switch-off value (Parameter) 191
- Switch-on delay (Parameter) 191
- Switch-on value (Parameter) 190
- Symbols
- For correction 81
 - In the text and numeric editor 81
- System components 122
- T**
- Table mode (Parameter) 172
- Table number (Parameter) 173
- Tank level (Parameter) 145

Tank type (Parameter)	139
Terminal voltage 1 (Parameter)	217
Thickness upper layer (Parameter)	216
Threaded connection	50
Timestamp (Parameter)	207, 208, 209
Tools	47
Transmitter	
Turning the display module	53
Turning the housing	53
Transmitter housing	
Turning	53
Trouble shooting	98
Tube diameter (Parameter)	139
Turning the display module	53
TV (HART device variable)	85

U

Underground tanks	39
Unit after linearization (Parameter)	169
Use calculated DC value (Parameter)	163, 164

V

Value 1 display (Parameter)	196
Value current output 1 to 2 (Parameter)	224
Value echo lost (Parameter)	176

W

W@M Device Viewer	112
Wizard	
Automatic DC calculation	164
Deactivate SIL/WHG	180
Define access code	206
Mapping	151
Probe length correction	183
SIL/WHG confirmation	179
Workplace safety	14
Write access	71
Write protection	
Via access code	72
Via write protection switch	74
Write protection switch	74



71320516

www.addresses.endress.com
