

# DUSTHUNTER T

Dust Concentration Monitor

Installation, Operation, Maintenance

**SICK**  
Sensor Intelligence.



---

**Described Product**

Product name: DUSTHUNTER T  
Variants: DUSTHUNTER T50  
DUSTHUNTER T100  
DUSTHUNTER T200

**Manufacturer**

SICK Engineering GmbH  
Bergener Ring 27 · D-01458 Ottendorf-Okrilla · Germany  
Phone: +49 7641 469-0  
E-Mail: info.pa@sick.de

**Trademarks**

Windows is a Microsoft Corporation trademark.  
Other product names used in this document may also be trademarks and are only used for identification purposes.

**Legal Information**

This document is protected by copyright. Any rights derived from the copyright shall be reserved for SICK AG. Reproduction of this document or parts of this document is only permissible within the limits of the legal determination of Copyright Law.  
Any modification, shortening or translation of this document is prohibited without the express written permission of SICK AG.  
The trademarks stated in this document are the property of their respective owner.

© SICK AG. All rights reserved.

**Original document**

This document is an original document of SICK AG.



## Contents

<b>1</b>	<b>Important Information .....</b>	<b>7</b>
1.1	Main hazards.....	7
1.1.1	Hazard through hot and/or aggressive gases and high pressure	7
1.1.2	Hazards through electrical equipment .....	7
1.2	Symbols and document conventions .....	8
1.2.1	Warning Symbols .....	8
1.2.2	Warning levels and signal words.....	8
1.2.3	Information symbols.....	8
1.3	Intended use .....	8
1.4	Responsibility of user.....	9
1.4.1	General information.....	9
1.4.2	Safety information and protective measures .....	9
<b>2</b>	<b>Product Description.....</b>	<b>11</b>
2.1	Measuring principle, measured variables.....	11
2.1.1	Functional principle .....	11
2.1.2	Response time .....	12
2.1.3	Function check.....	13
2.2	Device components .....	16
2.2.1	Sender/receiver unit .....	17
2.2.2	Reflector.....	20
2.2.3	Flange with tube .....	21
2.2.4	MCU control unit .....	22
2.2.4.1	Standard interfaces .....	22
2.2.4.2	Versions.....	23
2.2.4.3	Type code .....	25
2.2.4.4	Options .....	26
2.2.5	Optional external purge air unit .....	28
2.2.6	Installation accessories.....	29
2.2.6.1	Purge air supply and connection line .....	29
2.2.6.2	Weatherproof covers.....	29
2.2.7	Further options .....	29
2.2.7.1	Fail-safe shutters .....	29
2.2.7.2	Differential pressure sensor.....	29
2.2.7.3	Components for hall air monitoring.....	29
2.2.8	Device check accessories .....	31
2.2.8.1	Test equipment for linearity test .....	31
2.2.8.2	Adjusting stand for scaling .....	31
2.2.8.3	Zero tube for scaling .....	31
2.3	Device features and configuration .....	32
2.3.1	Device features.....	32
2.3.2	Device configuration.....	33
2.4	SOPAS ET (PC program) .....	34

- 3 Assembly and Installation ..... 35**
  - 3.1 Project planning..... 35
  - 3.2 Assembly ..... 36
    - 3.2.1 Fitting the flange with tube ..... 36
    - 3.2.2 Fitting the MCU control unit..... 39
    - 3.2.3 Fitting the optional external purge air unit..... 41
    - 3.2.4 Assembly work..... 42
    - 3.2.5 Fitting the weatherproof cover..... 43
    - 3.2.6 Installing fail-safe shutters ..... 44
    - 3.2.7 Components for hall air monitoring (option)..... 45
  - 3.3 Electrical installation ..... 46
    - 3.3.1 Electrical safety ..... 46
      - 3.3.1.1 Properly installed power isolating switches..... 46
      - 3.3.1.2 Lines with correct rating..... 46
      - 3.3.1.3 Grounding the devices..... 46
      - 3.3.1.4 Responsibility for system safety ..... 46
    - 3.3.2 General information, prerequisites ..... 47
    - 3.3.3 Installing the purge air supply ..... 47
      - 3.3.3.1 Control unit with integrated purge air supply (MCU-P) ..... 47
      - 3.3.3.2 Optional external purge air unit ..... 48
    - 3.3.4 Connecting the MCU control unit..... 50
      - 3.3.4.1 Work to be done ..... 50
      - 3.3.4.2 MCU processor board connections..... 51
      - 3.3.4.3 Connection of connection line to MCU ..... 52
      - 3.3.4.4 Standard connection ..... 53
    - 3.3.5 Connecting the MCU remote control unit..... 54
      - 3.3.5.1 Connection to the MCU control unit..... 54
      - 3.3.5.2 Connection to the MCU remote control unit..... 54
    - 3.3.6 Connecting the reflector on DUSTHUNTER T200..... 55
    - 3.3.7 Fitting the interface and I/O module (option) ..... 56
- 4 Start-up and Parameter Settings ..... 57**
  - 4.1 Basics..... 57
    - 4.1.1 General information ..... 57
    - 4.1.2 Installing SOPAS ET ..... 58
      - 4.1.2.1 Password for SOPAS ET menus..... 58
    - 4.1.3 Connection to the device via USB line ..... 58
      - 4.1.3.1 Finding the DUSTHUNTER COM port..... 58
    - 4.1.4 Connection to the device via Ethernet (option) ..... 60
  - 4.2 Application-specific settings..... 61
    - 4.2.1 Preparatory work ..... 61
    - 4.2.2 Focussing the sender light beam for transmission measurement ..... 64
    - 4.2.3 Scaling the measuring system for transmission measurement. 67
    - 4.2.4 Entering application-specific parameters ..... 69

4.3	Sender/receiver unit and reflector.....	71
4.3.1	Connection to the purge air supply.....	71
4.3.2	Fitting and connecting on the duct.....	71
4.4	Setting standard parameters .....	73
4.4.1	Assigning the MCU to the sender/receiver unit .....	73
4.4.2	Factory settings.....	74
4.4.3	Determining the function check.....	75
4.4.4	Setting the analog outputs parameters.....	76
4.4.5	Setting the analog inputs parameters .....	78
4.4.6	Setting the response time .....	79
4.4.7	Calibration for dust concentration measurement.....	80
4.4.8	Data backup in SOPAS ET .....	82
4.4.9	Starting measurement mode .....	83
4.5	Setting the Interface module parameters.....	84
4.5.1	General information.....	84
4.5.2	Setting the Ethernet module parameters .....	85
4.6	Operating/setting parameters via the optional LC-Display .....	86
4.6.1	General information on use .....	86
4.6.2	Password and operating levels .....	86
4.6.3	Menu structure .....	87
4.6.4	Configuration .....	87
4.6.4.1	MCU .....	87
4.6.4.2	Sender/receiver unit.....	90
4.6.5	Using SOPAS ET to modify display settings .....	91
<b>5</b>	<b>Maintenance.....</b>	<b>93</b>
5.1	General .....	93
5.2	Maintenance on the sender/receiver unit and reflector.....	95
5.2.1	Maintenance on the sender/receiver unit.....	95
5.2.2	Maintenance on the reflector.....	98
5.3	Maintenance on the purge air supply .....	101
5.3.1	Control unit MCU with integrated purge air supply .....	102
5.3.2	Optional external purge air unit .....	103
5.4	Shutdown.....	104
<b>6</b>	<b>Troubleshooting .....</b>	<b>105</b>
6.1	General .....	105
6.2	Sender/receiver unit.....	106
6.3	MCU control unit .....	108
6.3.1	Malfunctions .....	108
6.3.2	Warning and error messages in the SOPAS ET program .....	108
6.3.3	Replacing the fuse .....	110

- 7 Specifications .....111**
- 7.1 Compliances ..... 111
- 7.2 Technical Data ..... 112
  - 7.2.1 Dust concentration measuring range ..... 113
- 7.3 Dimensions, part Nos. .... 115
  - 7.3.1 Sender/receiver unit ..... 115
  - 7.3.2 Reflector ..... 117
  - 7.3.3 Reflector DHT-R0x, DHT-R1x ..... 117
  - 7.3.4 Flange with tube ..... 118
    - 7.3.4.1 Flange with tube (standard) ..... 118
    - 7.3.4.2 Flange with tube (fail-safe shutter) ..... 118
  - 7.3.5 MCU control unit ..... 119
  - 7.3.6 Optional external purge air unit ..... 121
  - 7.3.7 Weatherproof covers ..... 122
  - 7.3.8 Components for hall air monitoring (option) ..... 123
- 7.4 Accessories ..... 124
  - 7.4.1 Line sender/receiver unit - MCU ..... 124
  - 7.4.2 Line sender/receiver unit - reflector ..... 124
  - 7.4.3 Purge air supply ..... 124
  - 7.4.4 Assembly parts ..... 124
  - 7.4.5 Device check accessories ..... 124
  - 7.4.6 Options for MCU control unit ..... 125
  - 7.4.7 Miscellaneous ..... 125
- 7.5 Consumable parts for 2-years operation ..... 125
  - 7.5.1 Sender/receiver unit and reflector ..... 125
  - 7.5.2 MCU with integrated purge air supply ..... 125
  - 7.5.3 Optional external purge air unit ..... 125

# 1 Important Information

## 1.1 Main hazards

### 1.1.1 Hazard through hot and/or aggressive gases and high pressure

The optical subassemblies are fitted directly on the gas-carrying duct. On equipment with low hazard potential (no danger to health, ambient pressure, low temperatures), the installation or removal can be performed while the equipment is in operation providing the valid regulations and equipment safety notices are observed and suitable protective measures are taken.

**WARNING: Danger from exhaust gas**

- ▶ On equipment with gases detrimental to health, high pressure or high temperatures, the sender/receiver units and reflector components fitted on the duct may only be installed/removed when the equipment is at a standstill.
- 

### 1.1.2 Hazards through electrical equipment



**WARNING: Danger through power voltage**

The DUSTHUNTER T measuring system is classified as electrical.

- ▶ Disconnect power supply lines before working on power connections or parts carrying power voltage.
  - ▶ Refit any contact protection removed before switching the power voltage back on again.
-

## 1.2 Symbols and document conventions

### 1.2.1 Warning Symbols

Symbol	Significance
	Hazard (general)
	Hazard by voltage

### 1.2.2 Warning levels and signal words

**DANGER**

Risk or hazardous situation which *will* result in severe personal injury or death.

**WARNING**

Risk or hazardous situation which *could* result in severe personal injury or death.



**CAUTION**

Hazard or unsafe practice which *could* result in less severe or minor injuries.

**NOTICE**

Hazard which *could* result in property damage.

### 1.2.3 Information symbols

Symbol	Significance
	Important technical information for this product
	Important information on electric or electronic functions

## 1.3 Intended use

### Purpose of the device

The DUSTHUNTER T measuring system only serves continuous measurement of dust concentrations in exhaust gas and exhaust air plants.

### Correct use

- ▶ Use the device only as described in these Operating Instructions. The manufacturer bears no responsibility for any other use.
- ▶ Observe all measures necessary for conservation of value, e.g., for maintenance and inspection and/or transport and storage.
- Do not remove, add or modify any components to or on the device unless described and specified in the official manufacturer information. Otherwise
  - the device could become dangerous
  - the manufacturer's warranty becomes void

### Restrictions of use

- The DUSTHUNTER T measuring system is not approved for use in potentially explosive atmospheres.



## 1.4 Responsibility of user

### 1.4.1 General information

#### Designated users

The DUSTHUNTER T measuring system may only be installed and operated by skilled technicians who, based on their technical training and knowledge as well as knowledge of the relevant regulations, can assess the tasks given and recognize the hazards involved.

#### Special local conditions

- ▶ Observe the valid legal regulations as well as the technical rules deriving from implementation of these regulations applicable for the respective equipment during work preparation and performance.
- ▶ Carry out work according to the local conditions specific for the equipment as well as operational hazards and regulations.

#### Retention of documents

Keep the Operating Instructions belonging to the measuring system as well as equipment documentation onsite for reference at all times. Pass the respective documentation on to any new owner of the measuring system.

### 1.4.2 Safety information and protective measures

#### Protection devices



#### NOTE:

Depending on the particular hazard potential, an adequate number of suitable protection devices and personal safety equipment must be available and used by the personnel.

---

#### Behavior during purge air failure

The purge air supply serves to protect optical subassemblies fitted on the duct against hot or aggressive gases. Leave the supply switched on when the equipment is at a standstill. Optical subassemblies can be severely damaged in a short time if the purge air supply fails.



#### NOTE:

When no fail-safe shutters are fitted:

The user must ensure that:

- ▶ The purge air supply runs reliably and continuously
  - ▶ Failure of the purge air supply is immediately detected (e.g., by using pressure monitors)
  - ▶ Optical subassemblies are removed from the duct if the purge air supply fails and the duct opening is closed off (e.g. with a flange cover).
- 

#### Preventive measures for operating safety



#### NOTE:

The user must ensure that:

- ▶ Neither failures nor erroneous measurements can lead to operational states that can cause damage or become dangerous
  - ▶ The specified maintenance and inspection tasks are carried out regularly by qualified, experienced personnel.
-

### Recognizing malfunctions

Every deviation from normal operation is to be regarded as a serious indication of a functional impairment. These are, amongst others:

- Warning displays
- Significant drifts in measured results
- Increased power consumption
- Higher temperatures of system components
- Monitoring devices triggering
- Smells or smoke emission
- Heavy contamination.

### Avoiding damage



#### NOTE:

In order to avoid malfunctions that can cause direct or indirect personal injury or property damage, the operator must ensure:

- ▶ The responsible maintenance personnel are present at any time and as fast as possible
  - ▶ The maintenance personnel are adequately qualified to react correctly to malfunctions of the measuring system and any resulting operational interruptions (e.g., when used for measurement and control purposes)
  - ▶ The malfunctioning equipment is switched off immediately in case of doubt and that switching off does not cause collateral malfunctions.
- 

### Electrical connection

Ensure the device can be switched off with a power isolating switch/circuit breaker in accordance with EN 61010-1.

## 2 Product Description

### 2.1 Measuring principle, measured variables

#### 2.1.1 Functional principle

A high performance LED sends light in the visible range (white light, wavelength approx. 450 to 700 nm) through the active measuring path containing particles to the reflector where it is bounced back to the receiver. A highly sensitive measurement receiver accepts the signal weakened by particles, amplifies the signal electrically and feeds it to the measuring channel of a microprocessor as central part of the measuring, control and evaluation electronics.

Continuous monitoring of the sender output (partial beam to monitor receiver) registers the smallest changes in brightness of the light beam sent which then serves to determine the measurement signal.

Fig. 1: Measuring principle

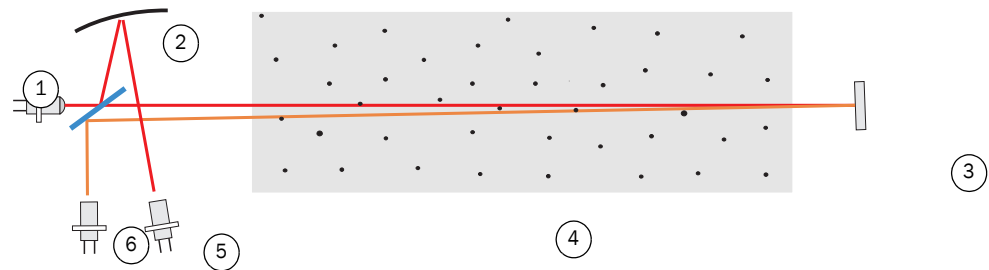

- |                  |                         |
|------------------|-------------------------|
| 1 LED            | 4 Active measuring path |
| 2 Concave mirror | 5 Monitor receiver      |
| 3 Reflector      | 6 Measurement receiver  |

#### Measured variables

The measuring system uses transmission (T) as primary optical measured variable. The other measured variables opacity (O), relative opacity (ROPA), extinction (E) and dust concentration (c) are derived from this variable.

Transmission, opacity, relative opacity:

$$T = N \cdot \frac{I_{\text{meas}}}{I_{\text{mon}}}$$

N = scaling constant  
I<sub>meas</sub> = light received  
I<sub>mon</sub> = monitor signal

$$O = 1 - T$$

$$\text{ROPA} = 1 - e^{-E \cdot \frac{D_{\text{Do}}}{2 \cdot D_{\text{meas}}}}$$

D<sub>Do</sub> = stack diameter at the top end  
D<sub>meas</sub> = active measuring path

Transmission, opacity and relative opacity are usually specified in percent.

Extinction:

$$E = \log\left(\frac{1}{T}\right)$$

Dust concentration:

Based on the Beer-Lambert law, the dust concentration is derived from the extinction as follows:

$$c = \frac{2,31 \cdot E}{k \cdot L} = K \cdot E$$

k= extinction constant

L = 2x active measuring path (due to double beam path)

Extinction is directly proportional to dust concentration for constant particle size and uniform dust distribution.

Particle size, dust density and dust distribution during differing load states influence transmission and extinction values and therefore the measuring system must be calibrated using a gravimetric comparison measurement for exact dust concentration measurement. The calibration coefficient determined can be entered directly in the measuring system as

$$c = cc2 \cdot E^2 + cc1 \cdot E + cc0$$

(Entry see “Calibration for dust concentration measurement”, page 80; standard factory setting: cc2 = 0, cc1 = 1, cc0 = 0).

2.1.2 Response time

The response time is the time required to attain 90% of the signal peak after a sudden change in the measurement signal. It can be set anywhere between 1 and 600 s. As the response time increases, transient measured value fluctuations and interruptions are damped stronger and stronger which “smooths out” the output signal.

Fig. 2: Response time

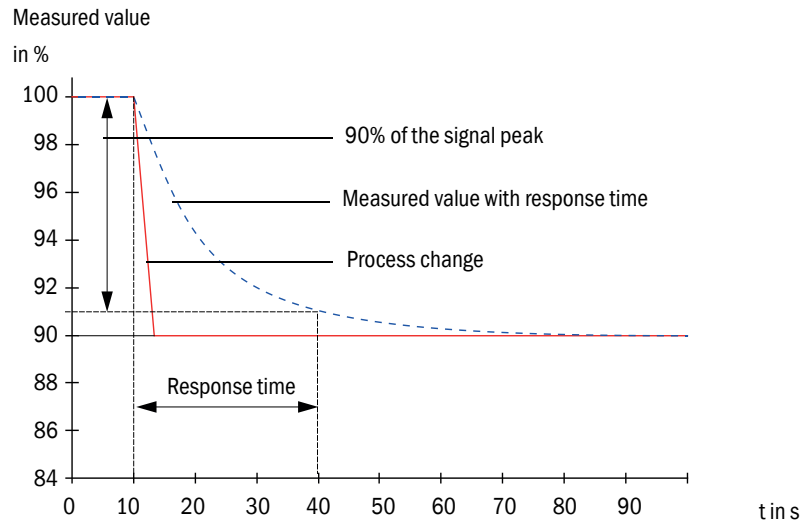

### 2.1.3 Function check

A function check can be triggered at fixed intervals as from a definable starting timepoint for an automatic function check of the measuring system. The setting can be made using the SOPAS ET operating program (see “Determining the function check”, page 75). Any unallowed deviations from normal behavior that may occur are signaled as errors. A function check triggered manually can help localize possible error causes should a device malfunction occur.



Further information → Service Manual

The function check comprises:

- Approx. 30 s measurement of contamination of optical interfaces (not for DUSTHUNTER T50), zero and control value  
The measuring time depends on the increase in contamination value (change > 0.5% → measurement is repeated up to 2 times).
- Every 90 s (standard value), output of values determined (duration parameter can be modified, see “Determining the function check”, page 75).

Fig. 3: Function check output on a plotter

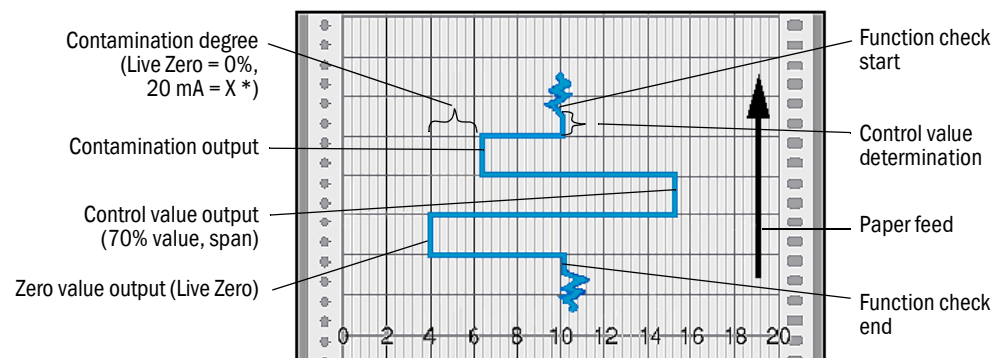

\*: X = 30% for  
DUSTHUNTER T100  
and 40% for  
DUSTHUNTER T200



- The analog output must be activated to output control values on the analog output (see “Setting the analog outputs parameters”, page 76).
- The value measured last is output on the analog output during control value determination.
- If the control values are not output on the analog output, the current measured value is output when control value determination has completed.
- During a function check, relay 3 is activated (see “MCU processor board connections”, page 51) and the green LED in the control window of the sender/receiver unit flashes (see “Sender/receiver unit”, page 17).
- A function check is not started automatically when the measuring system is in “Maintenance” mode.
- “Function check” is displayed on the display during the function check when using an MCU control unit with the optional Display module.
- If the start timepoint or cycle interval are changed, a check cycle timed between parameter setting and new start timepoint is still carried out.
- Changes to the interval time are first effective after the next start timepoint.

### Zero value measurement

The sender diode is switched off for zero point control so that no signal is received. This means possible drifts or zero point deviations are detected reliably in the overall system (e.g., due to an electronic defect). A warning signal is generated when the “zero value” is outside the specified range.

### Control value measurement (Span test)

Sender beam intensity changes between 70 and 100% during control value determination. The light intensity received is compared against the standard value (70%). The measuring system generates an error signal for deviations greater than  $\pm 2\%$ . The error message is cleared again when the next function check runs successfully. The control value is determined with high precision through statistical evaluation of a high number of intensity changes.

### Contamination measurement (not on DUSTHUNTER T50)

The glass panes positioned in the sender beam during normal measurement are swiveled away during contamination determination. The measured value determined and the value defined during scaling are used to calculate a correction factor [see “Scaling the measuring system for transmission measurement”, page 67](#). This fully compensates any contamination that occurs.

Contamination is determined on one side on the DUSTHUNTER T100 (pivoted shutter only on the sender/receiver unit) and on both sides on the DUSTHUNTER T200 (pivoted shutter also on the reflector).

Fig. 4: Contamination measurement principle (on both sides)

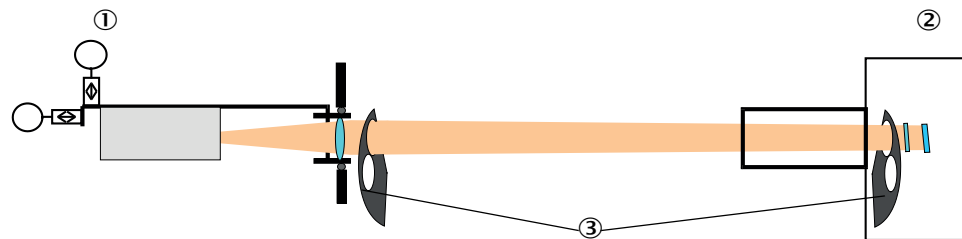

- ① Sender/receiver unit
- ② Reflector
- ③ Pivoted shutter

An analog value between live zero and 20 mA proportional to contamination is output during the check cycle for contamination values < 30%, (DUSTHUNTER T100) or 40% (DUSTHUNTER T200); when this value is exceeded, the “Failure” status is output (for the fault current set on the analog output for this case; [see “Factory settings”, page 74](#), [see “Setting the analog outputs parameters”, page 76](#)).

Fig. 5: Pivoted shutter settings on the sender/receiver unit

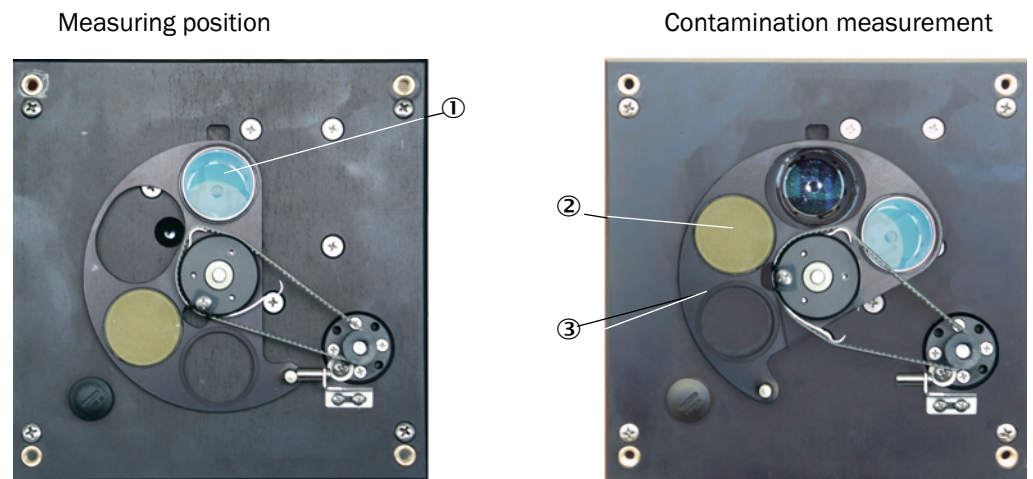

- ① Glass pane
- ② Control reflector (only on the sender side)
- ③ Pivoted shutter

2.2 Device components

Measuring system DUSTHUNTER T comprises as standard the components:

- Sender/receiver unit DHT-T
- Connection line to connect the sender/receiver unit to the MCU control unit (lengths 5 m, 10 m)
- Reflector DHT-R
- Connection line to connect the reflector to the sender/receiver unit (only for DUSTHUNTER T200, lengths 5 m, 10 m, 20 m, 50 m)
- Flange with tube
- MCU control unit to control, evaluate and output the data of the sender/receiver unit connected via the RS485 interface
  - With integrated purge air supply, for internal duct pressure -50 ... +2 hPa
  - Without purge air supply, therefore additionally required:
- Optional external purge air unit, for internal duct pressure -50 ... +30 hPa
- Purge air hose for supply by MCU control unit-P

Fig. 6: DUSTHUNTER T device components

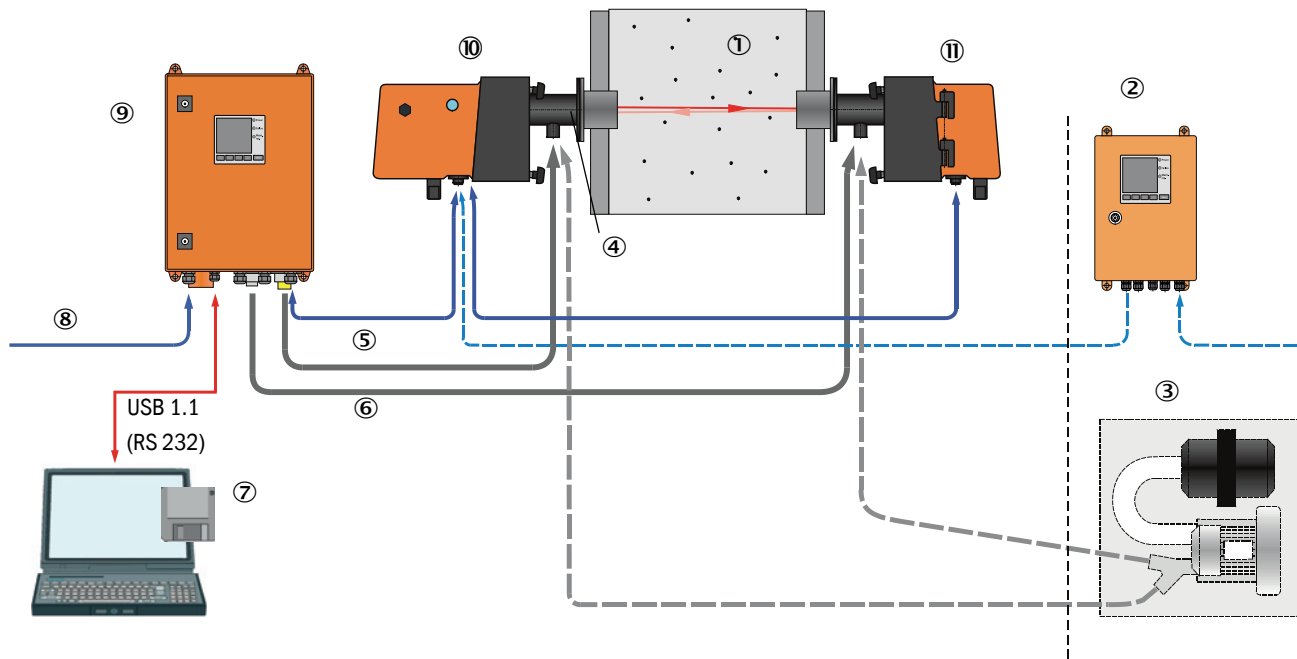

- |   |  |
|---|--|
| ① Duct                                    | ⑦ Operating and parameter program SOPAS ET |
| ② MCU-N without purge air supply (option) | ⑧ Power supply                             |
| ③ External purge air unit (option)        | ⑨ MCU-P with purge air supply              |
| ④ Flange with tube                        | ⑩ Sender/receiver unit                     |
| ⑤ Connection cable                        | ⑪ Reflector                                |
| ⑥ Purge air hose DN25                     |  |

Communication between sender/receiver unit and MCU control unit

As standard, each sender/receiver unit is connected to an MCU control unit via the connection line.



### 2.2.1 Sender/receiver unit

The sender/receiver unit contains the optical and electronics subassemblies to send and receive the reflected light beam as well as to process and evaluate the signals. Versions with contamination measurement are also fitted with swivel mechanisms (see [“Pivoted shutter settings on the sender/receiver unit”](#), page 15 and see [“Self-alignment principle design”](#), page 19).

Fig. 7: Sender/receiver unit DHT-Txx

Sender/receiver unit for DUSTHUNTER T50

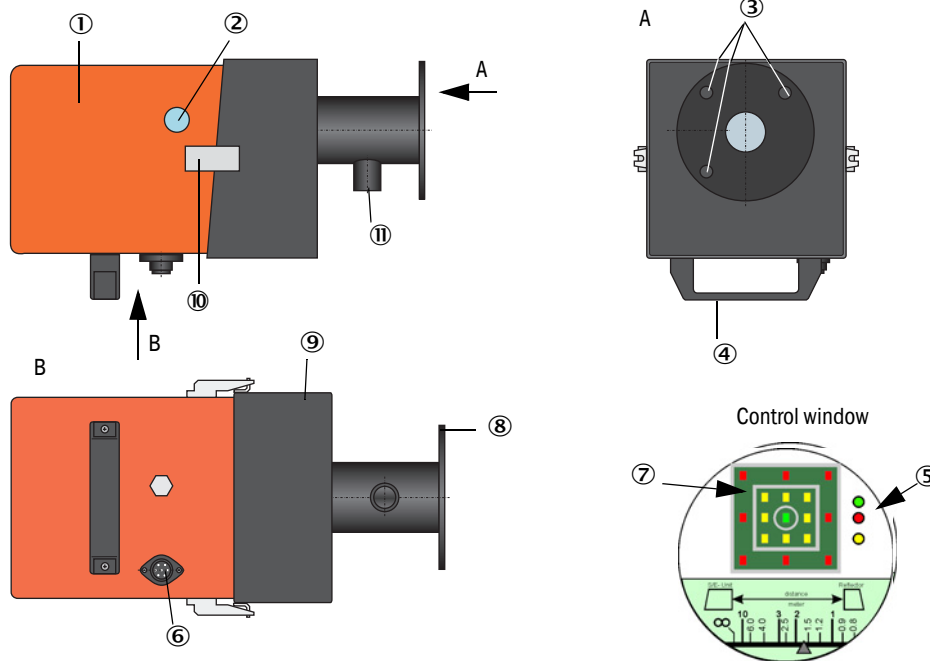

- ① Electronics unit
- ② Control window
- ③ Mounting holes
- ④ Handle
- ⑤ Status indicator
- ⑥ Connection for connection cable to MCU
- ⑦ Alignment indicator
- ⑧ Flange
- ⑨ Mounting attachment
- ⑩ CAMLOCK clip
- ⑪ Purge air connection

Sender/receiver unit for DUSTHUNTER T100/200

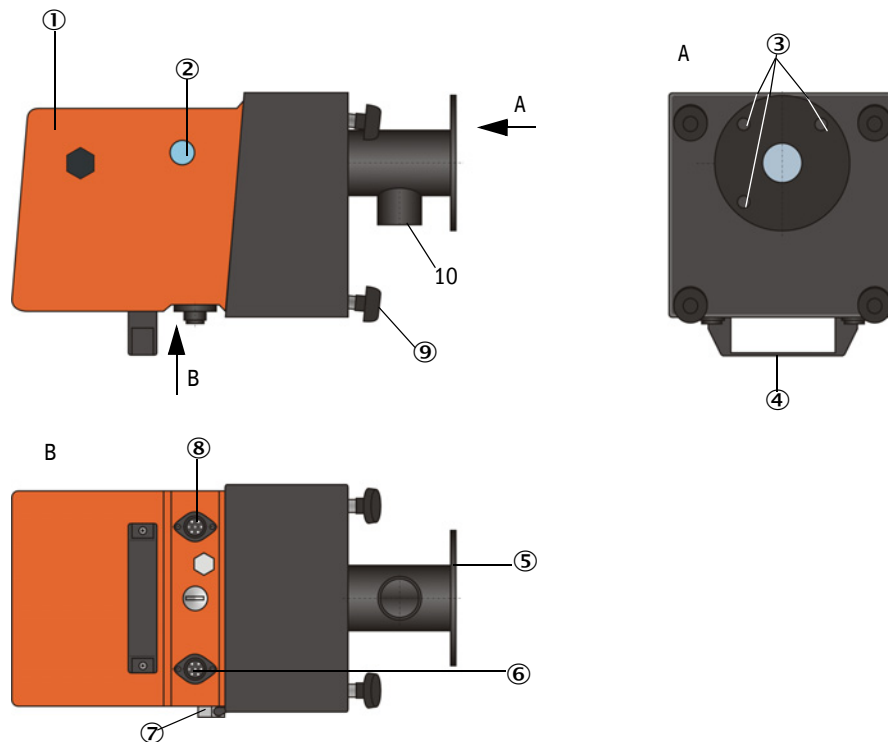

- ① Enclosure with electronics (swivel-mounted)
- ② Control window
- ③ Mounting holes
- ④ Handle
- ⑤ Flange
- ⑥ Connection for connection cable to MCU
- ⑦ Hinge
- ⑧ Connection for connection cable to reflector (only DUSTHUNTER T200)
- ⑨ Knurled screw
- ⑩ Purge air connection

Data transfer to and power supply (24 V DC) from the MCU control unit run via a shielded line with 4 wires and plug connector. An RS485 interface is available for service purposes. Clean air to cool the probe and keep the optical surfaces clean is fed via a purge air connection.

The sender/receiver unit is fastened to the duct with a flange with tube (see “Device components”, page 16).

The alignment of the optical axes as well as the current device state (operation = green LED, failure = red LED, maintenance request = yellow LED; see “Sender/receiver unit DHT-Txx”, page 17) are shown at the control window.

On DUSTHUNTER T100/T200, the enclosure with fitted sender/receiver unit can be swiveled to the side after the knurled screws have been loosened. Optics, electronics and mechanical components can then be easily accessed for maintenance work.

**Self-alignment functionality (only DUSTHUNTER T200)**

sender module can be moved horizontally and vertically using motors and bevel gears so that the sender light beam can be adjusted by approximately 2° in all directions. Tracking is performed using the measurement signal on the 4 quadrants of the measurement receiver. This allows automatic compensation of optical axis misalignment caused by, for example, distortion of duct walls due to temperature fluctuations.

Fig. 8: Self-alignment principle design

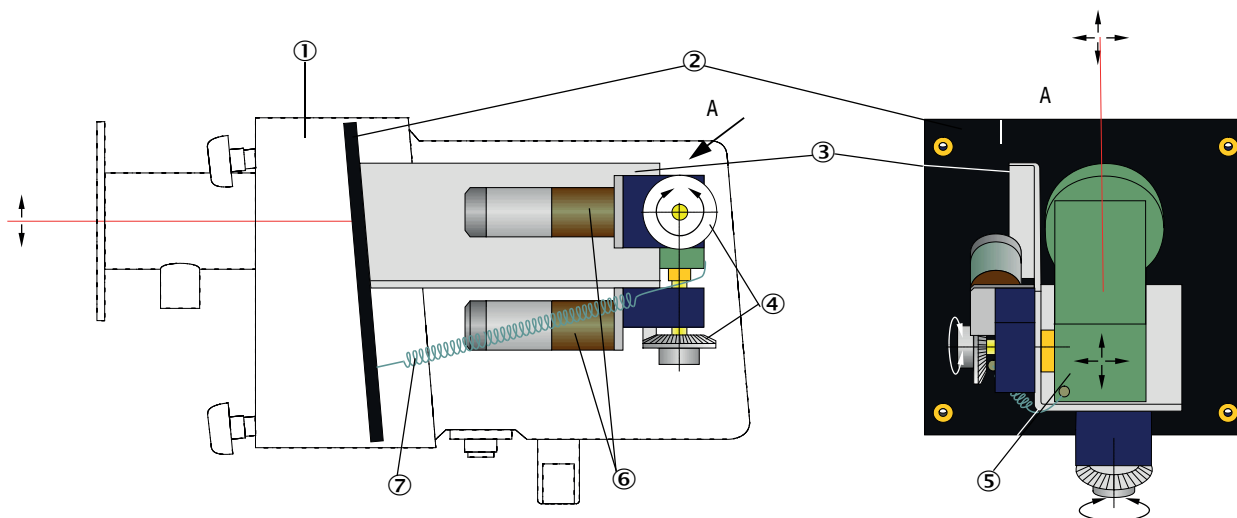

- ① Sender/receiver unit
- ② Base plate
- ③ Retaining bracket
- ④ Bevel gear
- ⑤ Sender module
- ⑥ Drive
- ⑦ Tension spring

**Type code**

A type code identifies the special version of the sender/receiver unit:

Sender/receiver unit:	DHT-TXX
Contamination measurement:	
- 0: Without	
- 1: With contamination measurement on one side (sender side only)	
- 2: With contamination measurement on both sides	
Self-alignment:	
- 0: Without	
- 1: With	

2.2.2 Reflector

The reflector reflects the sender light beam back to the receiver in the sender/receiver unit. Various versions are available for differing demands (internal duct diameter, contamination measurement) and are also identified with a type code.

Reflector	DHT-RXX
Version:	
- 5: for DUSTHUNTER T50	
- 0: Without contamination measurement	
- 1: With contamination measurement	
Measuring path:	
- 0: Short (0.5 ... 2.5 m)	
- 1: Medium (2 ... 5 m)	
- 2: Long (4 ... 8/12 m)	
- 3: Very long (10 ... 50 m)	

Fig. 9: Reflector

Reflector for DUSTHUNTER T50

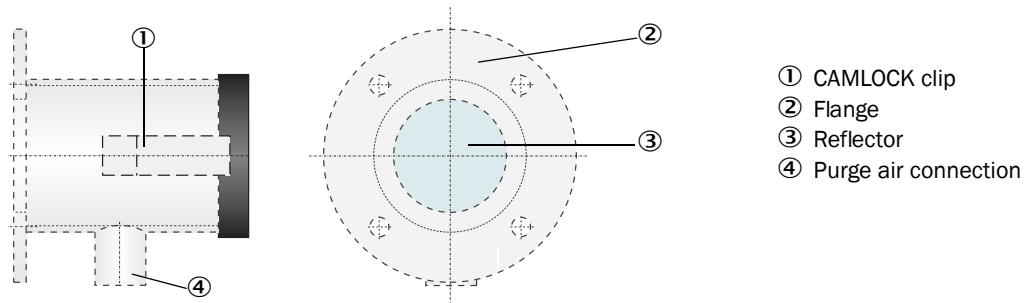

Reflector for DUSTHUNTER T100/T200

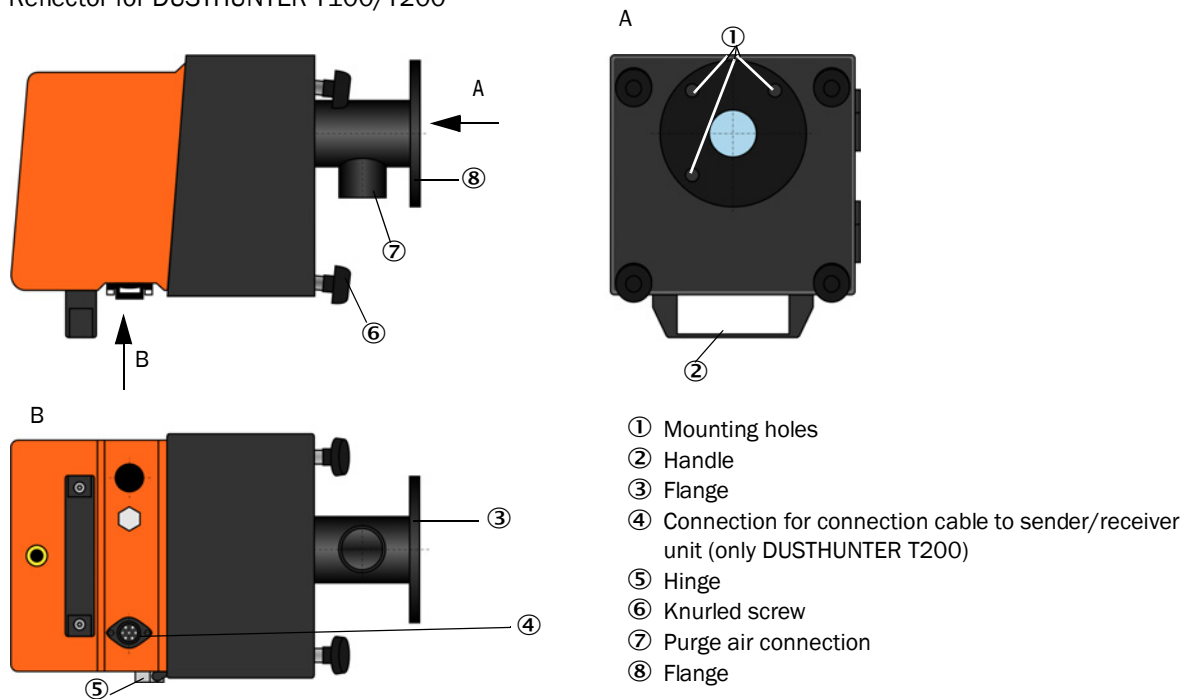

### 2.2.3 Flange with tube

The flange with tube is available in different steel grades and dimensions (see “Flange with tube”, page 118). Selection depends on the wall and isolation thickness of the duct wall (→ nominal length) and the duct material.

Fig. 10: Flange with tube

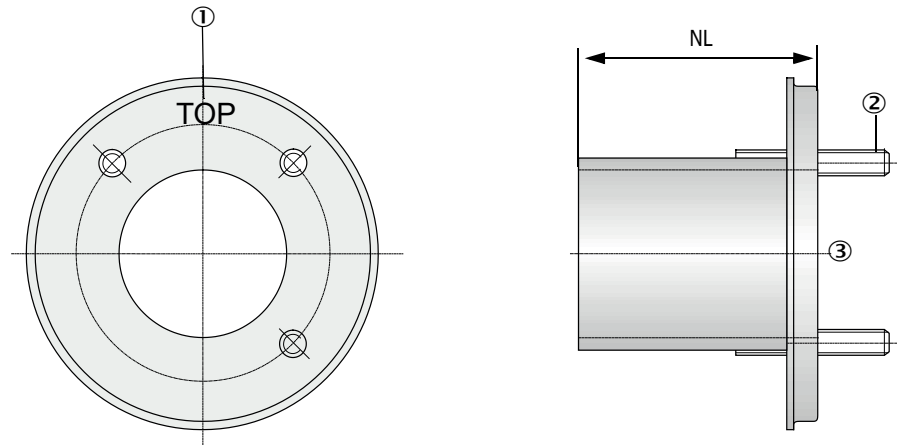

- ① Marking for assembly position
- ② Securing bolt
- ③ Material St 37 or 1.4571

### 2.2.4 MCU control unit

Control unit MCU has the following functions:

- Control of the data traffic and processing of the sender/receiver unit data connected via the RS485 interface
- Signal output via analog output (measured value) and relay outputs (device status)
- Signal input via analog and digital inputs
- Power supply for the connected measuring unit via 24 V switch-mode power supply with wide range input
- Communication with higher level control systems via optional modules

Equipment and device parameters can be set easily and conveniently via a USB interface using a PC and a user-friendly operating program. The parameters are stored reliably even in the case of a power failure.

Control unit MCU has a sheet steel enclosure as standard.

#### 2.2.4.1 Standard interfaces

Analog output	Analog inputs	Relay outputs	Digital inputs	Communication
0/2/4...22 mA (electrically isolated, active); resolution 10 bits <ul style="list-style-type: none"> <li>• 1x on DUSTHUNTER T50</li> <li>• 3x on DUSTHUNTER T100/200</li> </ul>	2 inputs 0 ... 20 mA (standard, without electrical isolation); Resolution 10 bits	5 changeover contacts (48 VAC, 1 A) to output status signals: <ul style="list-style-type: none"> <li>• Operation/failure</li> <li>• Maintenance</li> <li>• Function check</li> <li>• Maintenance request</li> <li>• Limit value</li> </ul>	4 inputs to connect potential-free contacts (e.g. to connect a maintenance switch, trigger a function check or further error messages)	<ul style="list-style-type: none"> <li>• USB 1.1 and RS232 (on terminals) for measured value inquiries, setting parameters and software updates.</li> <li>• RS485 for sensor connection</li> </ul>

2.2.4.2 Versions

- Control unit MCU-N without purge air supply

Fig. 11: Control unit MCU-N with options

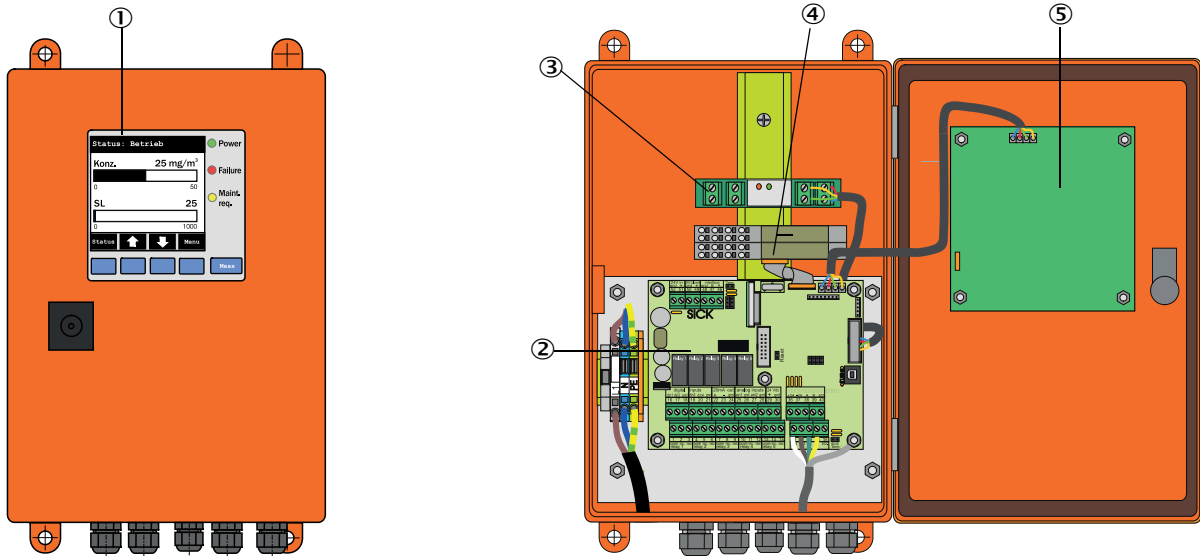

- ① Display module (option)
- ② Processor board
- ③ Interface module (option)

- ④ I/O module (option)
- ⑤ Display module (option)

- MCU-P control unit with integrated purge air supply  
This version is also fitted with a purge air blower, air filter and purge air connections to connect the purge air hoses to the sender/receiver unit and the reflector.

Fig. 12: MCU-P control unit with integrated purge air supply

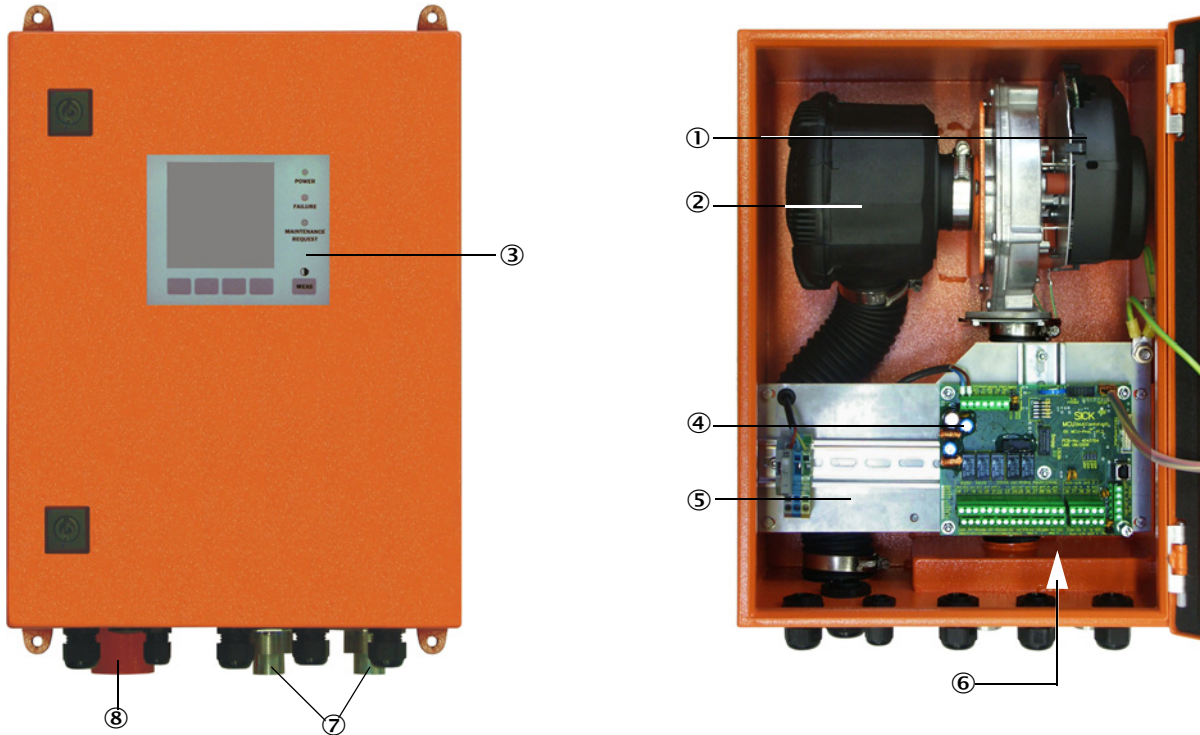

- |                           |   |
|---------------------------|---|
| ① Purge air blower        | ⑤ Installation plate                                |
| ② Air filter              | ⑥ Power supply unit (on back of installation plate) |
| ③ Optional Display module | ⑦ Purge air connection                              |
| ④ Processor board         | ⑧ Purge air inlet                                   |

The purge air hose (standard lengths 5 and 10 m (see “Purge air supply”, page 124)) is a separate part of the measuring system and must be ordered separately.



2.2.4.3 *Type code*

The following type code defines the various configuration options in the same manner as for the sender/receiver unit:

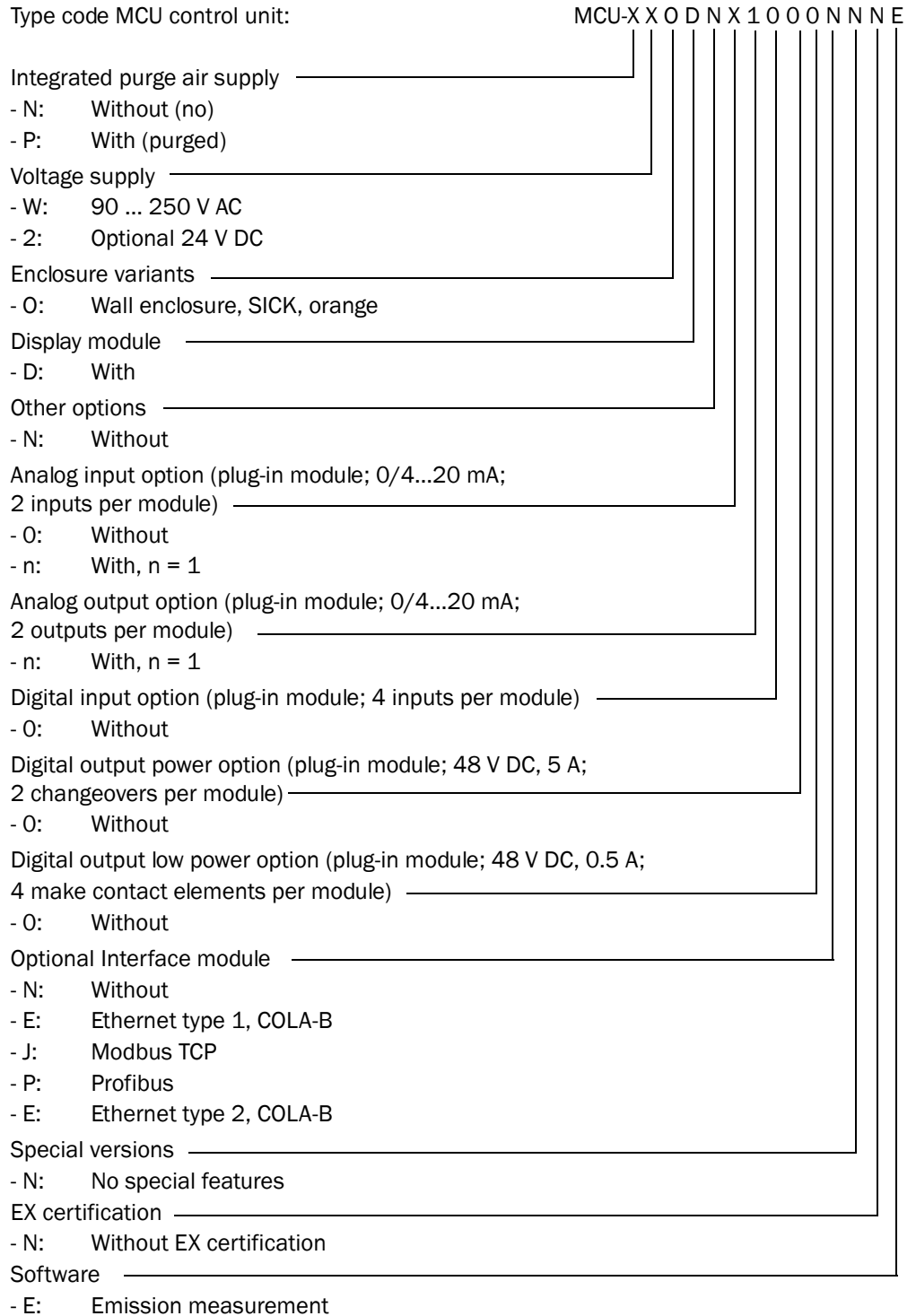

2.2.4.4 Options

The options described in the following can considerably expand the functionality of the MCU:

1 Display module

Module to display measured values and status information and for configuration during start-up, selection via operating buttons.

- +i** • Fitting this module in MCU control units already delivered must be done at the factory.
- This module is standard on DUSTHUNTER T100 and T200 versions.

a) Displays

Type		Display
LED	Power (green)	Voltage supply OK
	Failure (red)	Function fault
	Maintenance request (yellow)	Maintenance request
LC-Display	Graphic display (main screen)	Dust concentration Opacity
	Text display	5 measured values (see graphic display) and 7 diagnosis values (see “LC-Display menu structure”, page 87)

The graphic display shows two main measured values of a connected sender/receiver unit selected at the factory or calculated values from the MCU (e.g., scaled dust concentration) as bar charts. Alternatively, up to 8 single measured values of a sender/receiver unit can be displayed (toggle with “Meas” button).

Fig. 13: LC-Display with graphic (left) and text (right) display

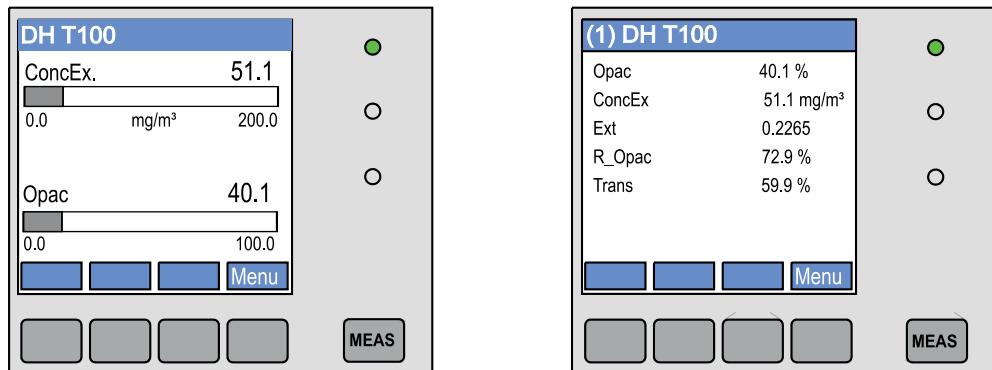

b) Control buttons

Button	Function
Meas	<ul style="list-style-type: none"> <li>• Toggle between text and graphic display</li> <li>• Display the contrast setting (after 2.5 s)</li> </ul>
Arrows	Select next/previous measured value page
Diag	Display alarm or fault message
Menu	Display of main menu and selection of submenus

## 2 I/O module

To be fitted on the module carrier (see “Options for MCU control unit”, page 125), optional as:

- 2x analog output 0/4 ... 22 mA to output further measured variables (max. load 500 Ω)
- 2x analog input 0/4 ... 22 mA to read-in values from external sensors (gas temperature, internal duct pressure, moisture, O<sub>2</sub>) to calculate the dust concentration in standard state.



- One module carrier is required per module (to plug in on the hat rail). One module carrier is connected to the processor board using a special line and another one is docked.
- For the DUSTHUNTER T50 version, a maximum of one analog input and 1 analog output module can be plugged on.
- For the DUSTHUNTER T100/T200 version, a maximum of 1 analog input module can be plugged on.

## 3 Interface module

Module to pass on measured values, system status and service information to higher level control systems, optionally for Profibus DP V0, Modbus TCP or Ethernet (type 1 or type 2), to plug onto a hat rail (see “Options for MCU control unit”, page 125). A corresponding line serves to connect the module to the processor board.



Profibus DP-V0 for transfer via RS485 according to DIN 19245 Part 3 as well as IEC 61158.

## 4 MCU remote control unit

The MCU remote control unit has identical functions to the MCU display near the device, however, it can be installed further away.

- Operating function the same as the MCU display
- Distance to the device:
  - MCU remote control unit without separate power supply unit: Max. 100 m
  - MCU remote control unit with own power supply unit: Max. 1000 m
- The MCU and the MCU remote control unit are interlocked (it is not possible to operate both MCUs at the same time).

### 2.2.5 Optional external purge air unit

The MCU control unit with integrated purge air supply cannot be used when the internal duct pressure is greater than +2 hPa. Use the optional external purge air unit in this case. It has a powerful blower and can be used for excess pressure in the duct up to 30 hPa. The scope of delivery includes a purge air hose with 40 mm nominal diameter (length 5 m or 10 m).

Fig. 14: Optional external purge air unit with adapter

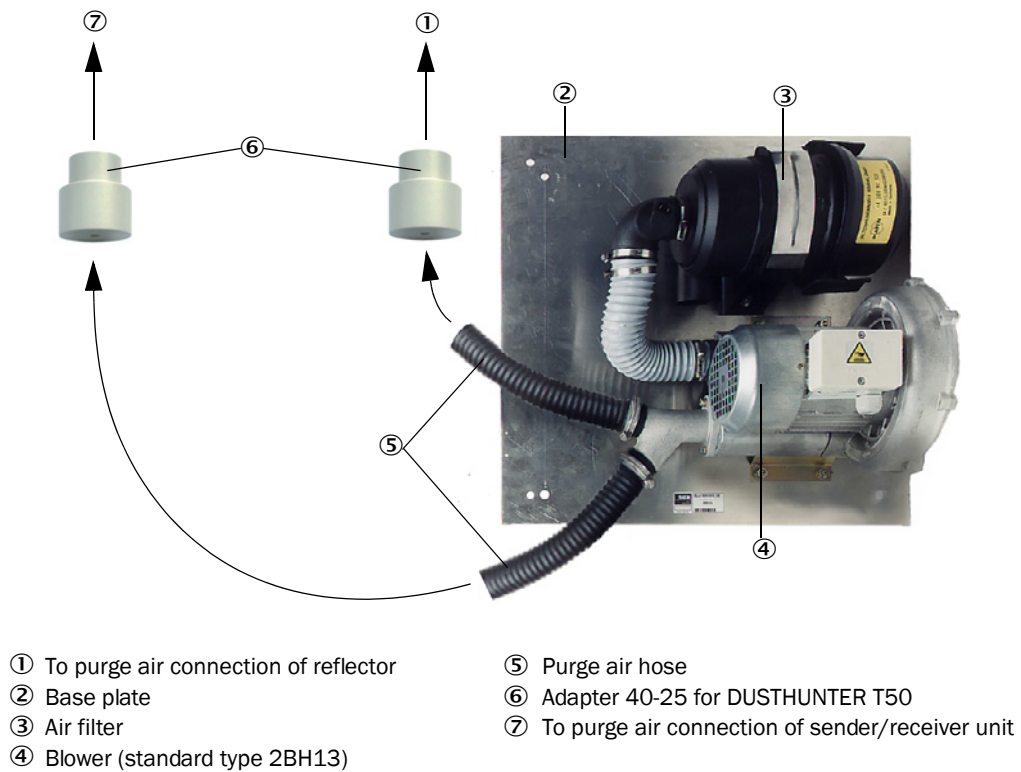

A weatherproof cover is available for use outdoors (see [“Weatherproof covers”](#), page 122).

**2.2.6 Installation accessories**

2.2.6.1 *Purge air supply and connection line*

	DUSTHUNTER T50	DUSTHUNTER T100	DUSTHUNTER T200
Purge air supply by MCU-P control unit	Purge air hose DN 25 mm for supply of sender/receiver unit and reflector	Purge air hose DN 40 mm for supply of sender/receiver unit and reflector	
Purge air supply by optional external purge air unit	Adapter 40-25	Purge air hose DN 40, if the purge air hose delivered is not sufficient	
Connection line	From MCU to sender/receiver unit		
			From sender/receiver unit to reflector

Purge air hoses can have different lengths.

2.2.6.2 *Weatherproof covers*

Weatherproof covers are available for sender/receiver units and reflectors used outdoors (see [“Weatherproof covers”](#), page 122).

**2.2.7 Further options**

2.2.7.1 *Fail-safe shutters*

For applications with overpressure in the duct we recommend to install fail-safe shutters for the protection of sender/receiver unit and reflector should the purge air supply fail (see [“Installing fail-safe shutters”](#), page 44). In addition, the optical components can also be maintained by external closing of these shutters even while the equipment is in operation without jeopardizing the staff.

2.2.7.2 *Differential pressure sensor*

The correct purge air supply can be monitored with pressure controllers (see [“Purge air supply”](#), page 124).

2.2.7.3 *Components for hall air monitoring*

A light/dust protection tube with matching holder for fitting the sender/receiver unit and reflector in factory halls or outdoors (e.g. for stockpile monitoring). Active measuring paths up to 50 m are therefore possible when installed vibration-free and distortion-free and when reflector DHT-R13 (see [“Reflector”](#), page 117) is used.



The connection line from the sender/receiver unit to the reflector is not required for DUSTHUNTER T50 and T100.

Fig. 15: Light/dust protection tube with holder

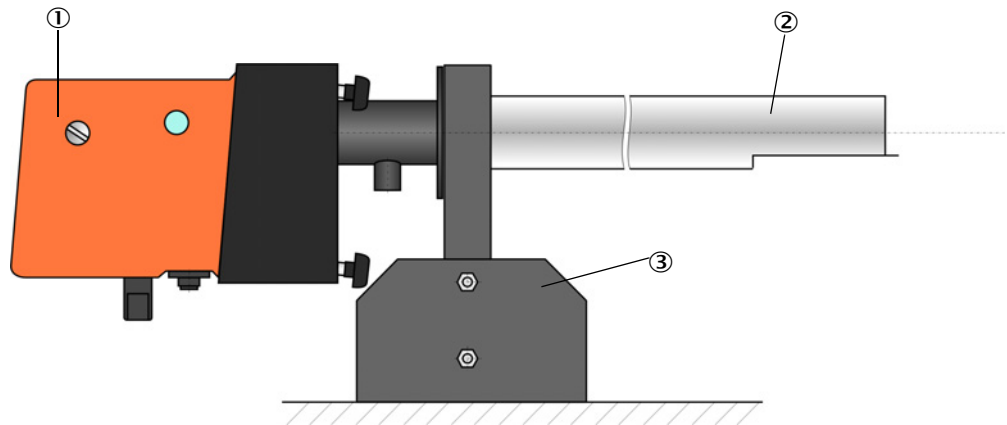

- ① Sender/receiver unit or reflector
- ② Light/dust protection tube
- ③ Holder for light/dust protection tube

## 2.2.8 Device check accessories

### 2.2.8.1 Test equipment for linearity test

A linearity test can serve to check the correct function of transmission measurement (see Service Manual). In this case, filter glasses with defined transmission values are positioned in the beam path and the values compared against those measured by the DUSTHUNTER T. Compliance within the allowed tolerance means the measuring system is working correctly. The filter glasses with holder required for the check are deliverable as a set including a carrying case (see “Device check accessories”, page 124).



Use the specified check filter set for a check according to US-EPA standard.

### 2.2.8.2 Adjusting stand for scaling

Adjusting stands are available to check transmission measurement in smoke-free measuring paths (see “Preparatory work”, page 61) and are fitted with a sender/receiver unit and reflector in a defined distance from each other and aligned so that the optical axes match (see “Focussing the sender light beam for transmission measurement”, page 64). The transmission value determined is set as 100% and serves as standard for measurement in the path containing dust.

### 2.2.8.3 Zero tube for scaling

The measuring system can also be scaled using a tube with a defined length instead of the adjusting stand (see “Preparatory work”, page 61). Assembling and aligning the sender/receiver unit and reflector in a dust-free path are then easier and more precise. We especially recommend this option when a dust-free environment cannot be guaranteed for scaling.

The zero tube is closed off with end flaps when not in use so that no dust can penetrate the tube.

### 2.3 Device features and configuration

#### 2.3.1 Device features

The DUSTHUNTER T measuring system is available in three different device versions with the following features:

Feature	Device version		
	DUSTHUNTER T50	DUSTHUNTER T100	DUSTHUNTER T200
Active measuring path	0.5...2.5/2...5/4...8 m	0.5...2.5/2...5/4...12 m	
Smallest measuring range	<ul style="list-style-type: none"> <li>• Transmission 100...50%</li> <li>• Opacity 0...50%</li> <li>• Extinction 0...0.3</li> </ul>	<ul style="list-style-type: none"> <li>• Transmission 100...80%</li> <li>• Opacity 0...20%</li> <li>• Extinction 0...0.1</li> </ul>	<ul style="list-style-type: none"> <li>• Transmission 100...90%</li> <li>• Opacity 0...10%</li> <li>• Extinction 0...0.045</li> </ul>
Measurement uncertainty	±0.8% transmission	±0.4% transmission	±0.2% transmission
Swivel error (at ±0.3°)	1% transmission	0.8% transmission	0.2% transmission
Contamination measurement	Without	On one side with pivoted shutter in sender/receiver unit	On both sides with pivoted shutter
Limit values (transmission)	None	20% for warning 30% for failure	30% for warning 40% for failure
Self-alignment	None		With
Display (on MCU)	Option	Standard	
Analog output	1	3 (2x with module)	
Analog input	2		
Digital input	4		
Relay outputs	5		



**2.3.2 Device configuration**

The device components required for a measuring system depend on the respective application conditions. The following Table should serve to assist you in your selection.

**Sender/receiver unit, reflector, flange with tube (standard components)**

Type	Active measuring path	Sender/receiver unit	Reflector	Line for reflector connection	Type MCU	Flange with tube
T50	0.5 ... 2.5 m	DHT-T00	DHT-R50	-	MCU-xxONN00000NNNE	Flange with tube k100 1x each for sender/ receiver unit and reflector
	2 ... 5 m		DHT-R51			
	4 ... 8 m		DHT-R52			
T100	0.5 ... 2.5 m	DHT-T10	DHT-R00	-	MCU-xxODN01000NNNE	
	2 ... 5 m		DHT-R01			
	4 ... 12 m		DHT-R02			
T200	0.5 ... 2.5 m	DHT-T21	DHT-R10	x	MCU-xxODN01000NNNE	
	2 ... 5 m		DHT-R11			
	4 ... 12 m		DHT-R12			
	10 ... 50 m		DHT-R13			

**Voltage and purge air supply**

Internal duct pressure	Connection and supply components	
	Purge air	Voltage
up to +2 hPa	MCU-P + purge air hose (see "Installation accessories", page 29)	
> +2 hPa bis +30 hPa	Optional external purge air unit	MCU-N



We recommend using the optional external purge air unit when the sender/receiver unit is more than 3 m away from the MCU control unit or reflector.

### 2.4 SOPAS ET (PC program)

SOPAS ET is a SICK Software for easy operation and configuration of the DUSTHUNTER.

SOPAS ET runs on a laptop/PC connected to the DUSTHUNTER via a USB line or Ethernet interface (option).

The menu structure simplifies changing settings. Further functions are also available (e.g., data storage, graphic displays).

SOPAS ET is delivered on the product CD. Alternatively, you can download SOPAS ET free of charge from the SICK homepage (“Downloads”).

## 3 Assembly and Installation

### 3.1 Project planning

The following Table provides an overview of the project planning work necessary as prerequisite for trouble-free assembly and subsequent device functionality. You can use this Table as a Checklist and check off the completed steps.

Task	Requirements	Work step	<input checked="" type="checkbox"/>	
Determine the measuring and installation locations for the device components	Inlet and outlet paths according to DIN EN 13284-1 (inlet at least 5x hydraulic diameter $d_h$ , outlet at least 3x $d_h$ ; distance to stack opening at least 5x $d_h$ )	For round and square ducts: $d_h$ = duct diameter  For rectangular ducts: $d_h$ = 4x cross-section divided by circumference	<ul style="list-style-type: none"> <li>Follow specifications for new equipment</li> <li>Select best possible location for existing equipment;</li> <li>For too short inlet/outlet paths: Inlet path &gt; outlet path</li> </ul>	<input type="checkbox"/>
	Homogeneous flow distribution Representative dust distribution	Whenever possible, no deflections, cross-section variations, feed and drain lines, flaps or fittings in the area of the inlet and outlet paths	If conditions cannot be ensured, define flow profile according to DIN EN 13284-1 and select best possible location	<input type="checkbox"/>
	Sender/receiver unit and reflector fitting location	Do not fit vertically on horizontal or slanted ducts; max. measuring axis angle to horizontal 45°	Select best possible location	<input type="checkbox"/>
	Accessibility, accident prevention	The device components must be easily and safely accessible	Provide platforms or pedestals as required	<input type="checkbox"/>
	Installation free of vibrations	Acceleration < 1 g	Eliminate/reduce vibrations through suitable measures	<input type="checkbox"/>
	Ambient conditions	Limit values according to Technical Data	If necessary: <ul style="list-style-type: none"> <li>Provide weatherproof covers/sun protection</li> <li>Enclose or lag device components</li> </ul>	<input type="checkbox"/>
Select the purge air supply	Sufficient primary purge air pressure depending on internal duct pressure	Up to +2 hPa, MCU control unit with integrated purge air supply Above +2 hPa to +30 hPa, optional external purge air unit	Select supply type	<input type="checkbox"/>
	Clean intake air	Whenever possible, low amount of dust, no oil, moisture or corrosive gases	<ul style="list-style-type: none"> <li>Select best possible location for air intake</li> <li>Determine required purge air hose length</li> </ul>	<input type="checkbox"/>
Select device components	Active measuring path, duct wall thickness with isolation	Sender/receiver unit, reflector, flange with tube	Select components according to the Configuration Table (see <a href="#">“Device features and configuration”, page 32</a> ); If necessary, plan additional measures to fit the flange with tube (see <a href="#">“Fitting the flange with tube”, page 36</a> )	<input type="checkbox"/>
	Internal duct pressure	Type of purge air supply		
	Fitting locations	Line and purge air hose lengths		
Plan calibration openings	Access	Easy and safe	Provide platforms or pedestals as	<input type="checkbox"/>
	Distances to measuring level	No mutual interference between calibration probe and measuring system	Plan sufficient distance between measuring and calibration level (approx. 500 mm)	<input type="checkbox"/>
Plan the voltage supply	Operating voltage, power requirements	According to Technical Data (see <a href="#">“Technical Data”, page 112</a> )	Plan adequate line cross-sections and fuses	<input type="checkbox"/>

3.2 Assembly

Carry out all assembly work onsite. This includes:

- ▶ Fitting the flange with tube
- ▶ Fitting the MCU control unit,
- ▶ Fitting the optional external purge air unit.



**WARNING:**

- ▶ Observe the relevant safety regulations as well as the safety notices during all work: see “Important Information”, page 7
- ▶ Consider the equipment weight specifications when planning the mounting brackets.
- ▶ Only carry out assembly work on equipment with hazard potential (hot or aggressive gases, higher internal duct pressure) when the equipment is at a standstill.
- ▶ Take suitable protection measures against possible local hazards or hazards arising from the equipment.



All dimensions specified in this Section are shown in mm.

3.2.1 Fitting the flange with tube

Fig. 16: Fitting the flanges with tube

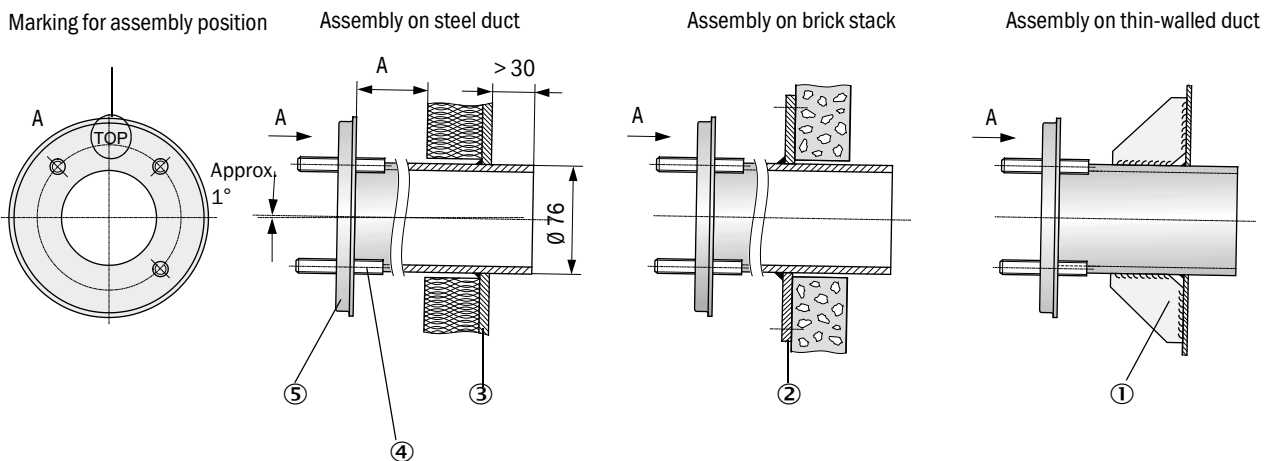

- ① Junction plate
- ② Anchor plate
- ③ Duct wall
- ④ Fixing bolt for weatherproof cover
- ⑤ Flange with tube

Dimension a must be large enough so that a weatherproof cover can be fitted easily when necessary (approx. 40 mm).

Onducts with strongly reflective material we recommend to define the measurement axis according to the following figure to prevent disturbing reflections influencing the measured value.

Fig. 17: Measurement axis in in strongly reflective ducts

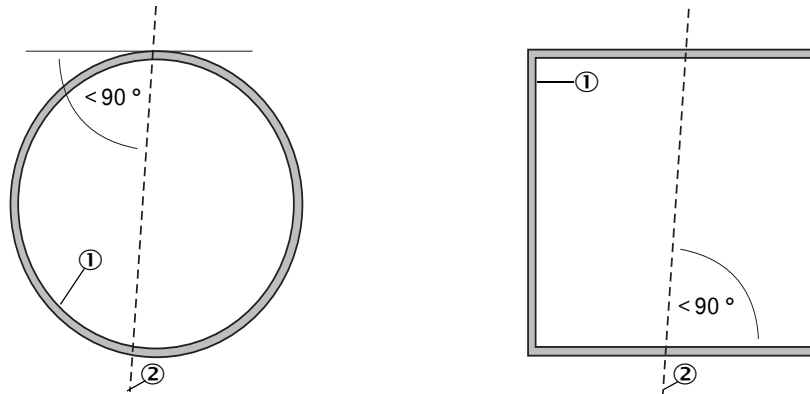

- ① Strongly reflective duct wall
- ② Measurement axis

**Work to be performed**

- ▶ Measure the fitting location and mark the assembly location.  
Leave enough clearance around the flange with tube to fit the sender/receiver unit and reflector.

Fig. 18: Clearance for sender/receiver unit and reflector (dimensions in mm)

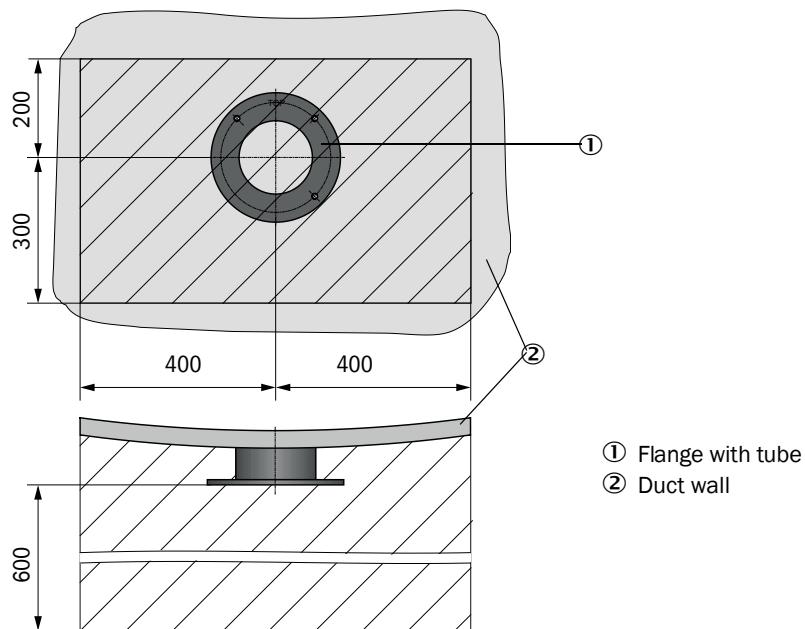

- ▶ Remove insulation (when fitted)

- ▶ Cut suitable openings in the duct wall; bore large enough holes in brick or concrete stacks (flange tube diameter (see “Flange with tube”, page 118))



**NOTE:**

- ▶ Do not let separated pieces fall into the duct.

- ▶ Insert the flange with tube in the opening so that the “Top” marking points upwards.
- ▶ Align the flanges with tube roughly to each other and weld on with a few welding spots (on the anchor plate for brick or concrete stacks, insert junction plates for thin-walled ducts ).
- ▶ Use a suitable tube (for narrower ducts) or the adjusting device from SICK to align the flange tubes to each other exactly after welding; axes deviation to each other max.  $\pm 1^\circ$ .

Fig. 19: Aligning the flanges with tube

Aligning with auxiliary tube

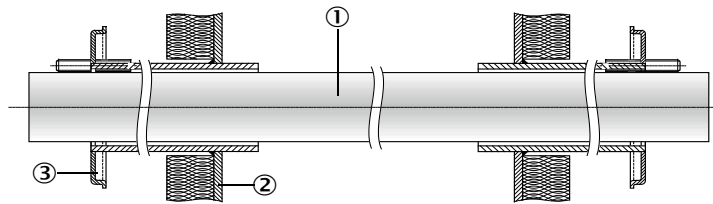

Aligning with adjusting device

(see “Options for MCU control unit”, page 125; also available on loan)

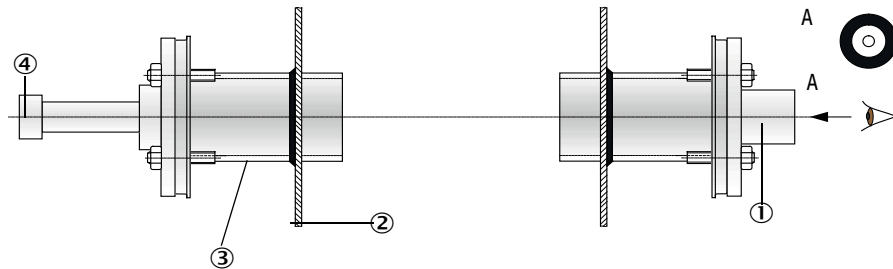

- ① Auxiliary tube
- ② Duct wall
- ③ Flange with tube
- ④ Light source



Use the target optics to align the flange so that the light spot of the lamp appears in the center of the target optics.

- ▶ Finally, weld the flange tubes tight all-round and, at the same time, check for exact alignment and correct when necessary. When using the adjusting device, assemble both the flange plate with light source and the flange plate with target optics before welding the second flange tube.
- ▶ Close off the flange opening after fitting to prevent gas escaping.

### 3.2.2 Fitting the MCU control unit

Fit the MCU control unit in a protected location that is easily accessible (see “MCU assembly dimensions”, page 39). Observe the following points during fitting:

- Maintain the ambient temperature according to the Technical Data; take possible radiant heat into consideration (shield when necessary).
- Protect against direct sunlight.
- Whenever possible, choose an assembly location with minimum vibrations; dampen any vibrations when necessary.
- Provide sufficient clearance for lines and opening the door.

#### Assembly dimensions

Fig. 20: MCU assembly dimensions

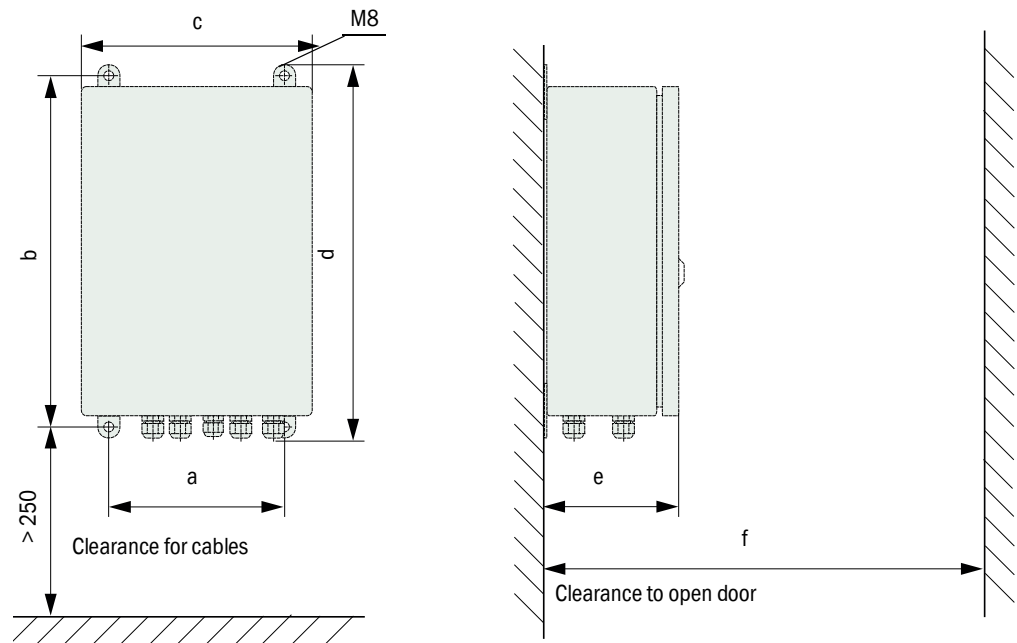

Dimension	Control unit type	
	MCU-N	MCU-P
a	160	260
b	320	420
c	210	300
d	340	440
e	125	220
f	> 350	> 540

MCU-N:  
Control unit without purge air supply  
MCU-P:  
Control unit with purge air supply  
(see “MCU control unit”, page 22)

Using a suitable line (see “General information, prerequisites”, page 47), the MCU-N control unit (without integrated purge air supply) can be located up to 1000 m away from the sender/receiver unit.

We therefore recommend fitting the MCU in a control room (measuring station or similar) to ensure free access to the MCU. This considerably simplifies communication with the measuring system in order to set parameters or to locate malfunction or error causes.

It is advantageous to provide weather protection (tin roof or similar), to be made onsite, for use outdoors.

### **Requirements when using the MCU-P control unit**

The following is applicable in addition to the general specifications:

- Install the MCU-P control unit at a location with clean air whenever possible. The air intake temperature must correspond to specifications in the Technical data (see “Technical Data”, page 112). In unfavorable conditions, lay an air intake hose to a location with better conditions.
- The purge air hoses to the sender/receiver unit and reflector should be as short as possible.
- When possible, lay the purge air hose so that no water can collect.
- We recommend using the optional external purge air unit when the sender/receiver unit and reflector are more than 10 m away from the MCU control unit.



### 3.2.3 Fitting the optional external purge air unit

Consider the following points when selecting the assembly location:

- ▶ Install the purge air unit at a location with clean air whenever possible. The air intake temperature must correspond to specifications in the Technical data (see [“Technical Data”, page 112](#)). In unfavorable conditions, lay an air intake hose or pipe to a location with better conditions.
- ▶ The fitting location must be easily accessible and meet all safety regulations.
- ▶ Install the purge air unit only as far as necessary below the flange with tube for the sender/receiver unit and reflector so that the purge air hoses can be laid downwards (avoids water collecting).
- ▶ Provide sufficient clearance to exchange the filter element.
- ▶ Provide sufficient space to attach and remove the weatherproof cover when installing the purge air unit outdoors see [“Purge air unit layout and assembly dimensions \(dimensions in mm\)”, page 42](#)).

#### 3.2.4 Assembly work

- ▶ Prepare holder (see “Purge air unit layout and assembly dimensions (dimensions in mm)”, page 42).
- ▶ Fasten purge air unit with 4 M8 screws.
- ▶ Check whether the filter element is fitted in the filter housing otherwise fit when necessary.

Fig. 21: Purge air unit layout and assembly dimensions (dimensions in mm)

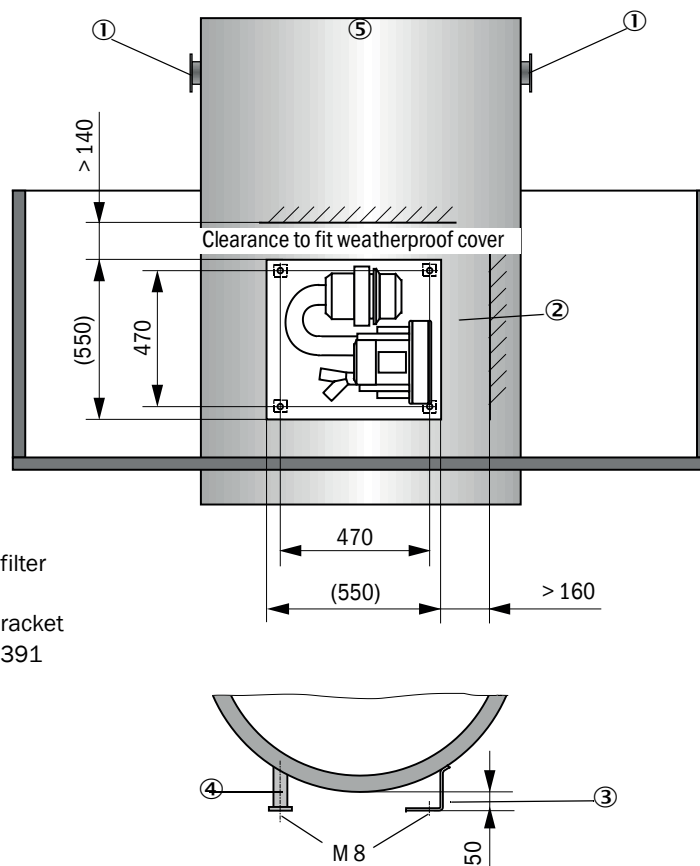

- ① Flange with tube
- ② Clearance to exchange filter element
- ③ Alternative: Mounting bracket
- ④ Steel pipe 50 x 5 DIN 2391
- ⑤ Duct

### 3.2.5 Fitting the weatherproof cover

#### Weatherproof cover for analyzer

##### Assembly

- ▶ Push the base plate (2) sideways on the flange with tube (5), slot onto the threaded bolts (4) of the duct-side surface of the flange plate and screw tight (see “Fitting the weatherproof cover for analyzer (dimensions in mm)”, page 43).
- ▶ Put the cover (1) on from above.
- ▶ Insert the side holding catches (3) into the counterpieces, twist and lock in.

Fig. 22: Fitting the weatherproof cover for analyzer (dimensions in mm)

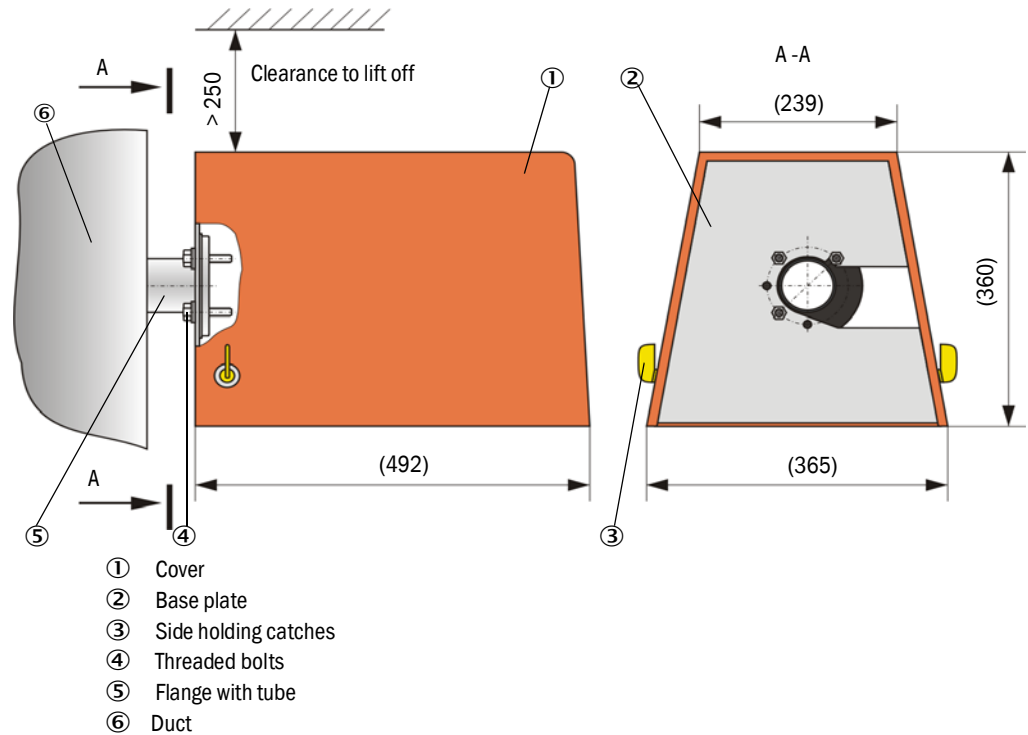

#### Weatherproof cover for external purge air unit

The weatherproof cover (see “Weatherproof covers”, page 122) comprises a cover and locking set.

##### Assembly:

- ▶ Mount the locking pins from the locking set on the base plate.
- ▶ Put the weatherproof cover on from above.
- ▶ Insert the holding catches into the counterpieces from the side, twist and lock in.

#### 3.2.6 Installing fail-safe shutters

##### Function

The fail-safe shutters protect the device from dust from the stack.

Close the fail-safe shutters:

- When the voltage fails.
- When a differential pressure sensor is available and the differential pressure sensor outputs a corresponding signal (the pressure from the stack is too high).

Fig. 23: Fitting fail-safe shutter and optional weatherproof cover

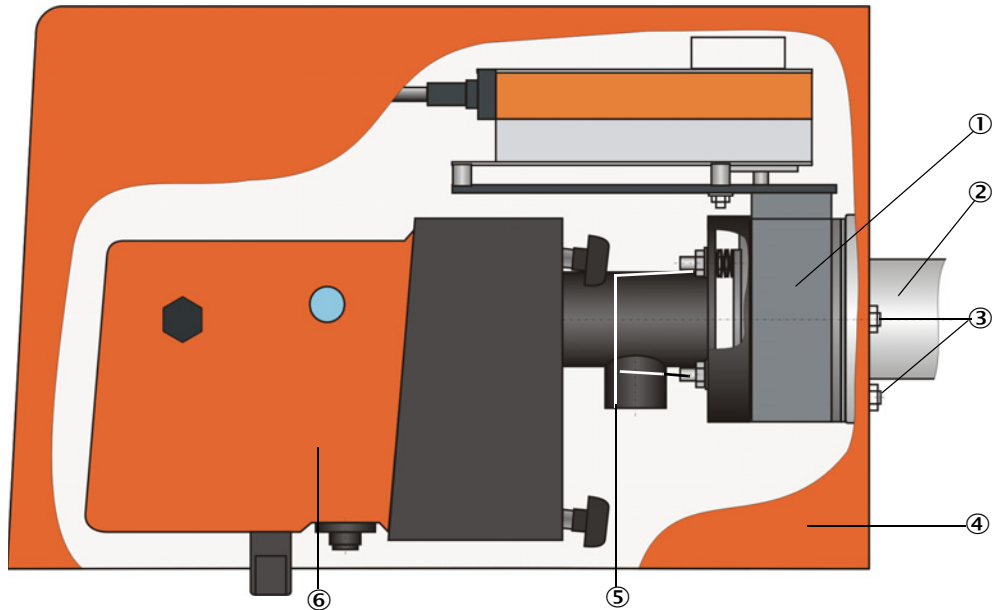

- |                     |                             |
|---------------------|-----------------------------|
| ① Fail-safe shutter | ④ Weatherproof cover        |
| ② Flange with tube  | ⑤ Bolt of fail-safe shutter |
| ③ Bolts             | ⑥ Sender/receiver unit      |

##### Assembly

- ▶ Screw fail-safe shutter (1) (see [“Purge air supply”, page 124](#)) with delivered bolts (3) to the flange with tube for fitting the fail-safe shutter (2) (see [“Flange with tube \(fail-safe shutter\)”, page 118](#)).
- ▶ Fasten sender/receiver unit (6) and/or reflector to bolts (3) of the fail-safe shutter.
- ▶ Electrical connection: See enclosed Operating Instructions of the fail-safe shutter.
- ▶ If a weatherproof cover (4) is to be installed, fasten the base plate on the duct side of the flange to the bolts of fail-safe shutter (5), then place on and fasten the cover (compare see [“Fitting the weatherproof cover”, page 43](#)).



- For protection of the sender/receiver unit, use the weatherproof cover for analyzer, extended for FSS (Part No. 2065677, see [“Weatherproof covers”, page 122](#)).
- The weatherproof cover for analyzer (Part No. 2702407, see [“Weatherproof covers”, page 122](#)) is sufficient for protection of the reflector.

### 3.2.7 Components for hall air monitoring (option)

- ▶ Install the holder for the light/dust protection tube on an even, vibration-free surface (dimensions see “Components for hall air monitoring (option)”, page 123).



**NOTE:**

The installation locations must be determined so that the optics of sender/receiver unit and reflector cannot be subjected to direct light sources (emitter, sun, etc.).

Fig. 24: Incorrect mounting arrangement

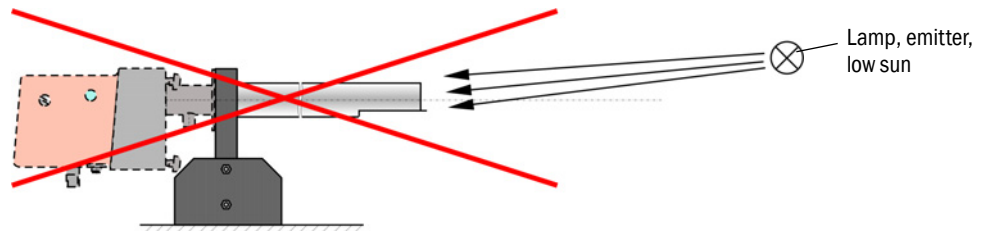

- ▶ Screw on light/dust protection tubes.
- ▶ Align optical axes with each other using a laser pointer. For this purpose:
  - ▶ Cover the light/dust protection tube with transparent film in the area of the holder.
  - ▶ Attach the laser pointer centrally on the other light/dust protection tube and check whether the light spot on the film is in the middle of the tube. If not, correct the alignment of the light/dust protection tubes.
  - ▶ Repeat procedure in reverse sequence

### 3.3 Electrical installation

#### 3.3.1 Electrical safety



**WARNING:**

- ▶ Observe the relevant safety regulations as well as the safety notices in [see “Important Information”, page 7](#) during all installation work.
  - ▶ Take suitable protection measures against possible local hazards or hazards arising from the equipment.
- 

##### 3.3.1.1 Properly installed power isolating switches



**WARNING:**

- Endangerment of electrical safety during installation and maintenance work when the power supply is not switched off. An electrical accident can occur during installation and maintenance work when the power supply to the device or lines is not switched off using a power isolating switch/circuit breaker.
- ▶ Before starting work on the device, ensure the power supply can be switched off using a power isolating switch/circuit breaker in accordance with DIN EN 61010.
  - ▶ Make sure the power isolating switch is easily accessible.
  - ▶ An additional disconnecting device is mandatory when the power isolating switch cannot be accessed or only with difficulty after installation.
  - ▶ The power supply may only be activated again after the work or for test purposes by personnel carrying out the work under consideration of valid safety regulations.
- 

##### 3.3.1.2 Lines with correct rating



**WARNING:**

- Endangerment of electrical safety through power line with incorrect rating. Electrical accidents can occur when the specifications for replacement of a removable power line have not been adequately observed.
- ▶ Always observe the exact specifications in the Operating Instructions (Technical Data Section) when replacing a removable power line.
- 

##### 3.3.1.3 Grounding the devices



**CAUTION:**

- Device damage through incorrect or missing grounding.
- ▶ During installation and maintenance work, it must be ensured that the protective grounding to the devices and/or lines involved is effective in accordance with EN 61010-1.
- 

##### 3.3.1.4 Responsibility for system safety



**WARNING:**

- Responsibility for the safety of a system.
- ▶ The person setting the system up is responsible for the safety of the system in which the device is integrated.
-

### 3.3.2 General information, prerequisites

All assembly work previously described must be completed (as far as applicable) before starting installation work.

Carry out all installation work onsite unless otherwise explicitly agreed with SICK or authorized representatives. This includes laying and connecting the power supply and signal lines, installing switches and power fuses and connecting the purge air supply.



- Plan adequate line cross-sections (see “Technical Data”, page 112).
- Line ends with plugs to connect the sender/receiver unit must have sufficient free length.

### 3.3.3 Installing the purge air supply

- ▶ Lay the purge air hoses with shortest paths and free of bends, shorten as required.
- ▶ Maintain sufficient distance from hot duct walls.

#### 3.3.3.1 Control unit with integrated purge air supply (MCU-P)

Connect the DN40 purge air hose to the purge air outlets on the underside of the MCU-P and secure with a strap retainer. Set the purge air outlets as shown (correct when necessary).

Fig. 25: Underside of MCU-P

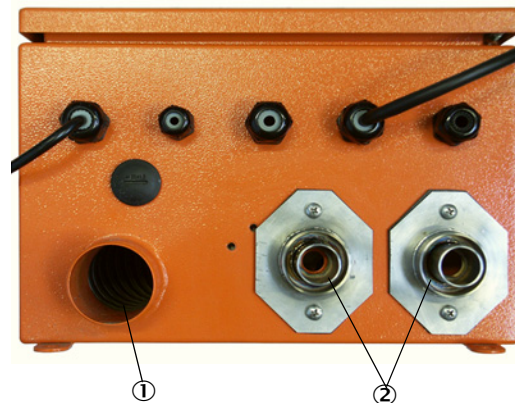

- ① Purge air inlet
- ② Purge air outlet DN 40

#### 3.3.3.2 Optional external purge air unit

##### Connect the purge air hose

Connect the purge air hose DN 40 mm and secure with hose clamps D32-52.

Fig. 26: Connecting the optional external purge air unit

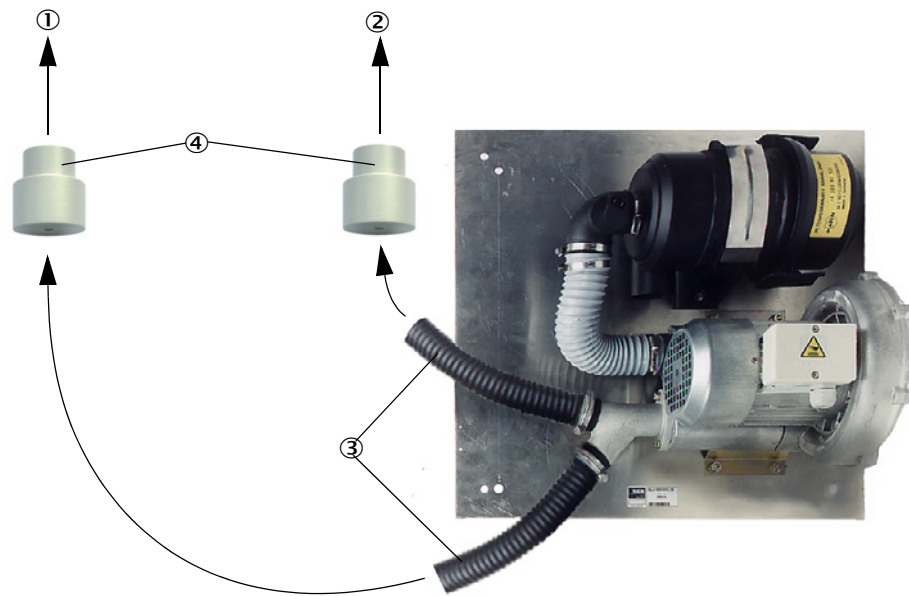

- ① Purge air connection of sender/receiver unit
- ② Purge air connection of reflector
- ③ Purge air hose
- ④ Adapter 40-25, required only for DUSTHUNTER T50



**Electrical connection**

- ▶ Compare power voltage and frequency with the specifications on the type plate on the purge air motor.



**CAUTION:**

- ▶ Only connect when these match!

- ▶ Connect the power supply line to the purge air motor terminals (refer to the supplementary sheet on the purge air motor and lid of the motor terminal box for terminal allocation).

Fig. 27: Electrical connection of the external purge air unit

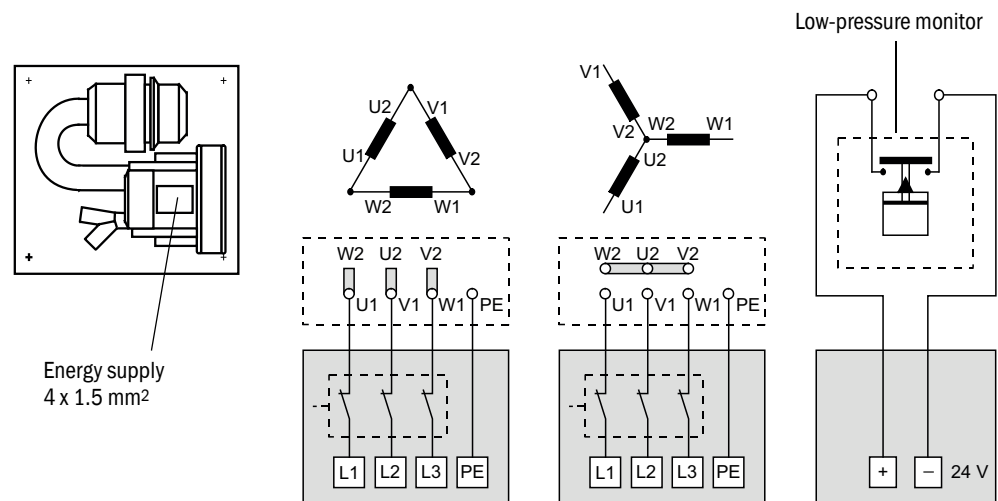

- ▶ Connect protective conductor to terminal.
- ▶ Set motor circuit breakers according to the blower connection data (see Technical Data for purge air unit) to a value 10% above the rated current.



**NOTE:**

In case of doubt or when using a special motor version, the operating instructions supplied with the motor have priority over any other information.

- ▶ Check the function and running direction of the blower (purge air flow direction must match the arrows on the inlet and outlet openings on the blower). For wrong direction on 3-phase motors: Swap power connections L1 and L2.
- ▶ Connect the pressure controller (option) to monitor purge air feed.



**NOTE:**

- ▶ Use a fail-safe power supply (standby unit, rails with redundant supply)
- ▶ Fuse the purge air unit separate from the other system components. The fuse type must match the rated current (see technical details of purge air unit). Fuse each phase separately. Use circuit breakers to prevent phase failures on one side.

#### 3.3.4 Connecting the MCU control unit

Fig. 28: Component layout in the MCU (without purge air supply, with options)

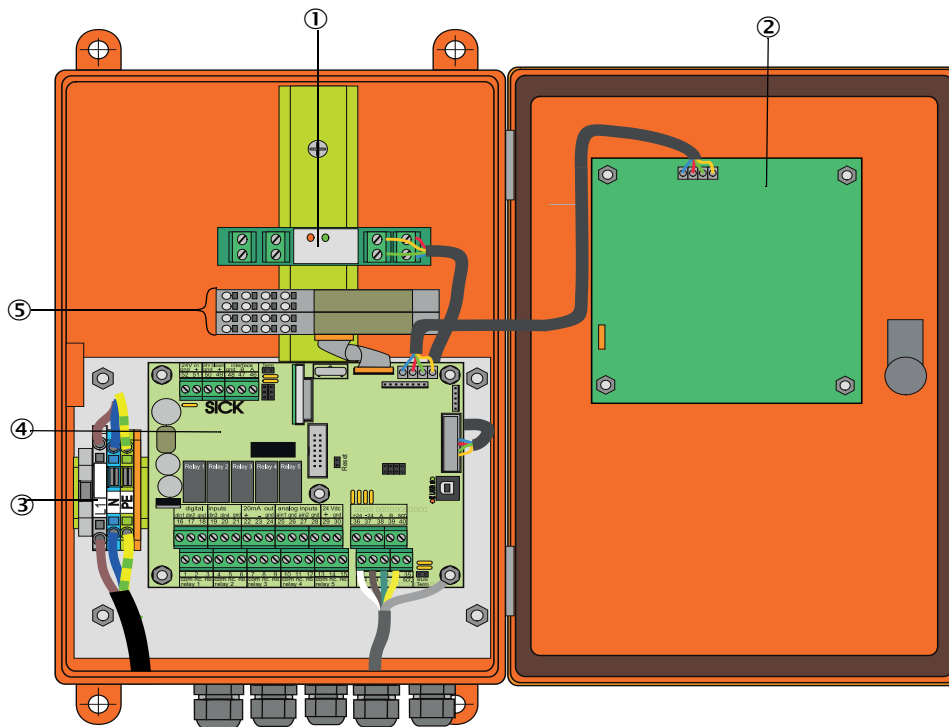

- ① Optional Interface module
- ② Optional Display module
- ③ Terminals for power connection
- ④ Processor board
- ⑤ Optional I/O modules

##### 3.3.4.1 Work to be done

- ▶ Connect the connection line: see “Standard connection”, page 53.



If an onsite line is to be used, it must be connected to a suitable 7-pole socket (see “Plug connector connection to onsite line”, page 52; SICK Part No.: 7045569).

- ▶ Connect lines for status signals (operation/failure, maintenance, function check, maintenance request, limit value), analog output, analog and digital inputs according to requirements (see “Standard connection”, page 53, p. 56, Fig. 33 and Fig. “Terminal assignment of analog input module”; only use shielded lines with twisted pairs).



#### NOTICE:

- ▶ Only use shielded lines with twisted pairs (e.g., UNITRONIC LiYCY (TP) 2 x 2 x 0.5 mm<sup>2</sup> from LAPPKabel; 1 pair of wires for RS 485, 1 pair of wires for power supply; not suitable for underground laying).

- ▶ Connect power line to terminals L1, N, PE of the MCU (see “Component layout in the MCU (without purge air supply, with options)”, page 50).
- ▶ Close off unused line openings with dummy plugs.



#### WARNING:

- ▶ Be sure to check the wiring before switching the supply voltage on.
- ▶ Only modify wiring when disconnected from the power supply and potential-free.

3.3.4.2 MCU processor board connections

Fig. 29: MCU processor board connections

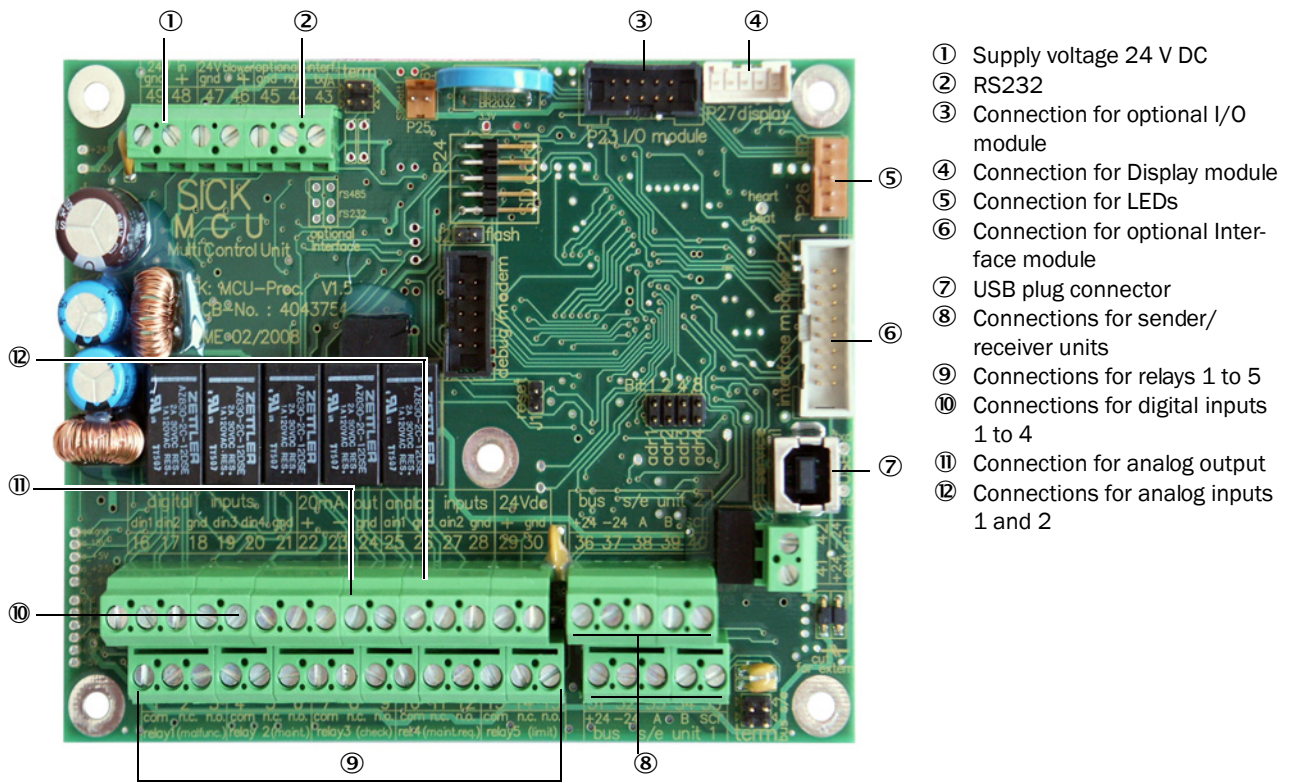

- ① Supply voltage 24 V DC
- ② RS232
- ③ Connection for optional I/O module
- ④ Connection for Display module
- ⑤ Connection for LEDs
- ⑥ Connection for optional Interface module
- ⑦ USB plug connector
- ⑧ Connections for sender/receiver units
- ⑨ Connections for relays 1 to 5
- ⑩ Connections for digital inputs 1 to 4
- ⑪ Connection for analog output
- ⑫ Connections for analog inputs 1 and 2

3.3.4.3 Connection of connection line to MCU

Fig. 30: Plug connector connection to onsite line

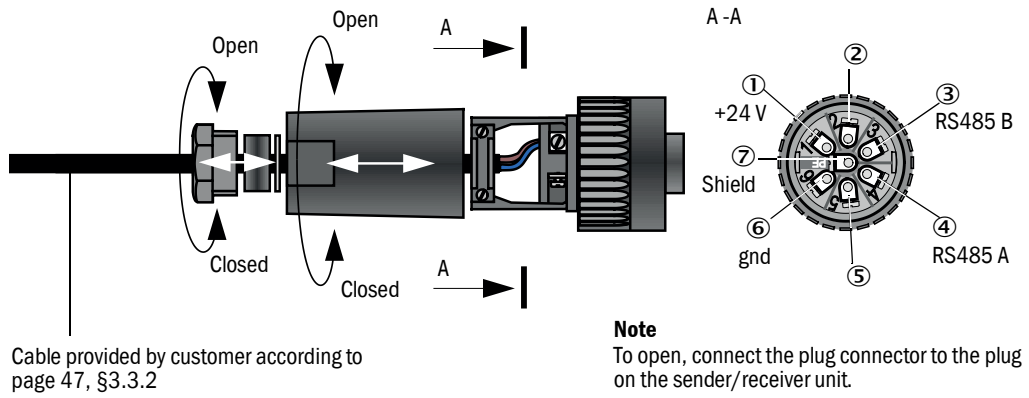

3.3.4.4 Standard connection

Fig. 31: Standard connection

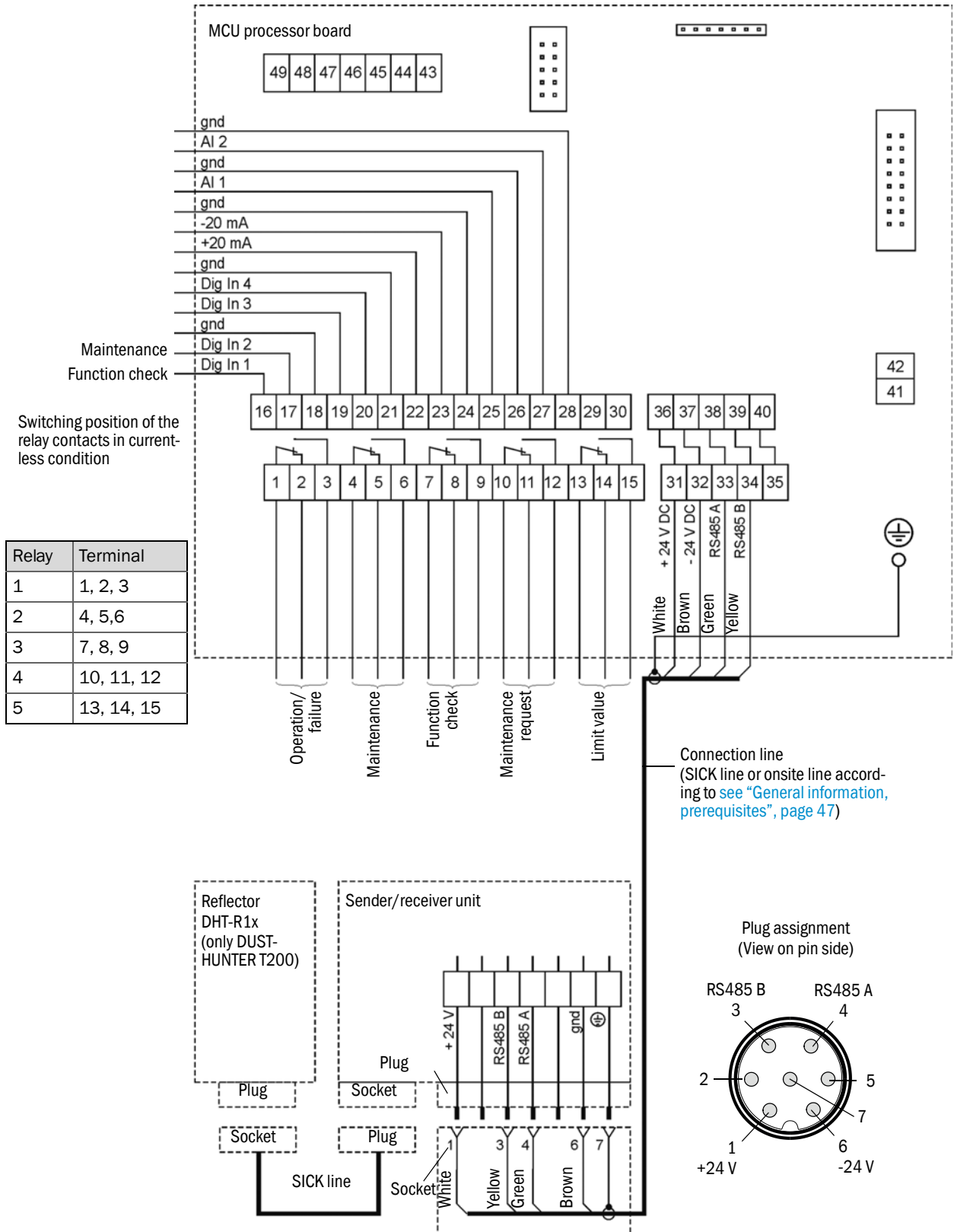

#### 3.3.5 Connecting the MCU remote control unit

##### 3.3.5.1 Connection to the MCU control unit

Electrical connection see “Standard connection”, page 53

- Electrical connection of the MCU remote control unit without an own power supply unit:
  - 24V supply: Terminals 36 and 37 (or equivalent)
  - Signals: Terminals 38 and 39 (or equivalent)
- Electrical connection of the MCU remote control unit with an own power supply unit:
  - Signals: Terminals 38 and 39 (or equivalent)

##### 3.3.5.2 Connection to the MCU remote control unit

###### Version without power supply unit

- Connect the connection cable to the measuring and control unit (4-wire, twisted pair, with shield) to the connections in the control unit and the module of the remote unit.

Fig. 32: Connections in the remote control unit (version with integrated wide-range power pack)

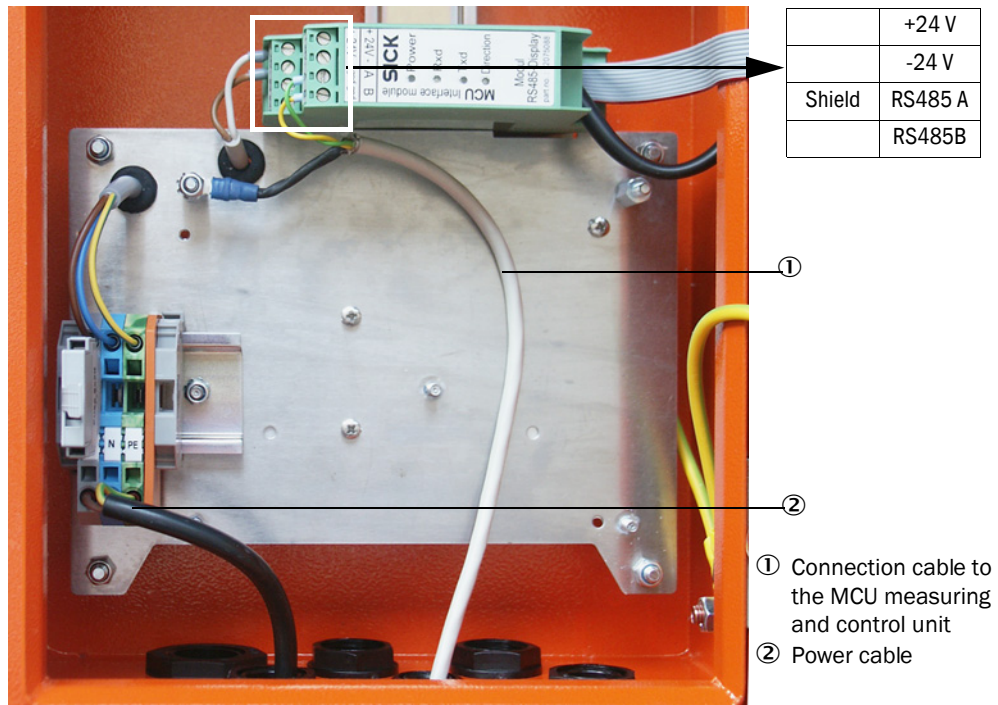

**Version with integrated wide-range power pack:**

- Connect the 2-wire cable (twisted pair, with shield) to the connections for RS485 A/B and shield in the control and remote control unit.
- Connect the 3-wire power cable with sufficient cross-section to the onsite power supply and the corresponding terminals in the remote unit.

**NOTICE:**

- ▶ During installation, it must be possible to switch the power supply off using a power isolating switch/circuit breaker in accordance with EN 61010-1.
- ▶ After completion of the work or for test purposes, the power supply may only be activated again by the personnel who carried out the work and complying with the valid safety regulations.

**3.3.6 Connecting the reflector on DUSTHUNTER T200**

Connect the cable belonging to this component (see [“Line sender/receiver unit - reflector”](#), page 124) to the sender/receiver unit and reflector and screw tight.

3.3.7 Fitting the interface and I/O module (option)

Plug Interface modules and module carriers for I/O modules onto the hat rail in the MCU (see “Component layout in the MCU (without purge air supply, with options)”, page 50) and connect to the associated connection on the processor board with the line with plug connector (see “MCU processor board connections”, page 51). Then plug the I/O modules on the module carriers.

Connect the Interface modules using the customer provided network line to the local network. Use the terminals on the module carrier to connect I/O modules.

Terminal assignment of AO module

Fig. 33: Terminal assignment of analog output module

① Module carrier

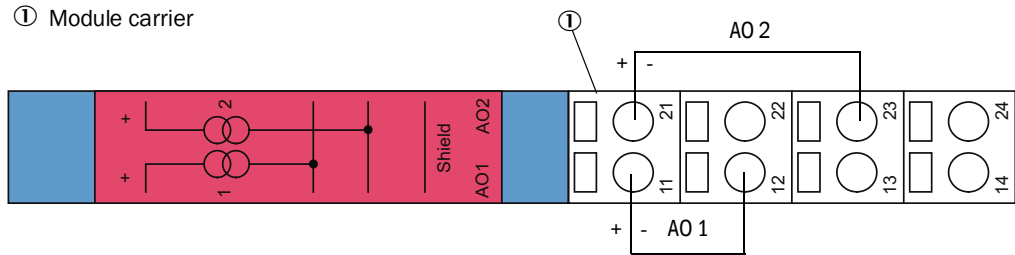

Terminal assignment of AI module

Fig. 34: Terminal assignment of analog input module

① Module carrier

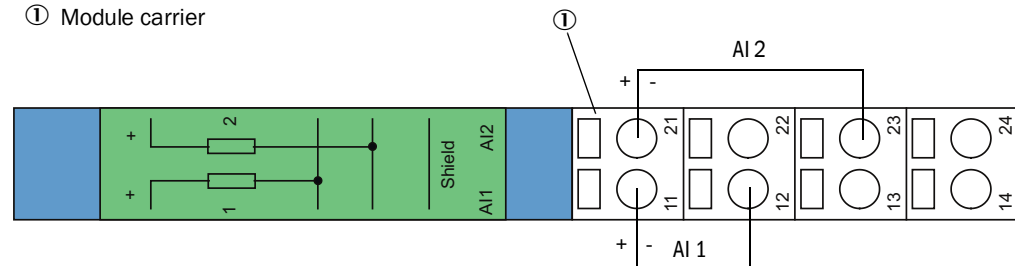



## 4 Start-up and Parameter Settings

### 4.1 Basics

#### 4.1.1 General information

Assembly and installation must have been completed according to Section 3 before starting the work described in the following.

Start-up and parameter setting comprise:

- Setting the measuring system to the duct dimensions
- Fitting and connecting the sender/receiver unit and reflector
- Customizing parameter settings according to the respective requirements.

To achieve exact measurement, the measuring system must first be calibrated using a gravimetric comparison measurement (see [“Calibration for dust concentration measurement”](#), page 80) before being used for continuous measurement of dust content.

### 4.1.2 Installing SOPAS ET

- Install SOPAS ET on a laptop/PC.
- Start SOPAS ET.
- Following the installation instructions of SOPAS ET.

#### 4.1.2.1 Password for SOPAS ET menus

Certain device functions are first accessible after a password has been entered.

User level		Access to
0	Operator	Displays measured values and system states No password required
1	Authorized operator	Displays, inquiries as well as start-up or adjustment to customer-specific demands and diagnosis of necessary parameters. Preset password: sickoptic

### 4.1.3 Connection to the device via USB line

Recommended procedure:

- 1 Connect the USB line to the MCU control unit (see “MCU processor board connections”, page 51) and the laptop/PC.
- 2 Switch the device on.
- 3 Start SOPAS ET.
- 4 “Search settings”
- 5 “Device family oriented search”
- 6 Click the desired MCU.
- 7 Make the settings:
  - Ethernet communication (always clicked)
  - USB communication (always clicked)
  - Serial communication: Click
- 8 Do not specify IP addresses.
- 9 A list of COM ports is shown.  
Specify the COM port of the DUSTHUNTER.  
If you do not know the COM port: see “Finding the DUSTHUNTER COM port”, page 58
- 10 Assign a name for this search.
- 11 “Finish”

#### 4.1.3.1 Finding the DUSTHUNTER COM port

If you do not know your COM port: You can find the COM port with the Windows Device Manager (Administrator rights are not required).

- 1 Disconnect the DUSTHUNTER from your laptop/PC.
- 2 Input: `devmgmt.msc`

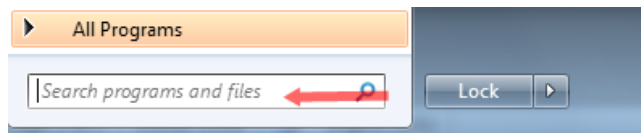

3 This message is shown:

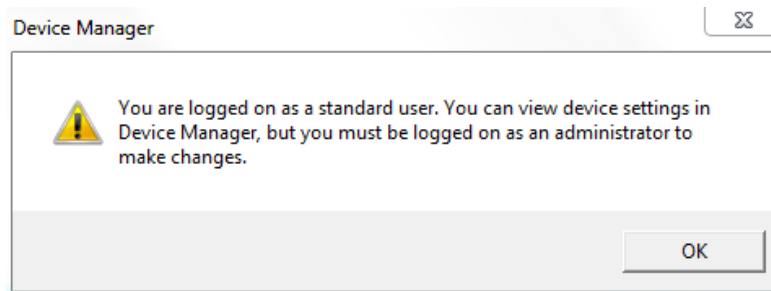

4 “OK”

5 The Device Manager opens.

See: “Ports (COM & LPT)”

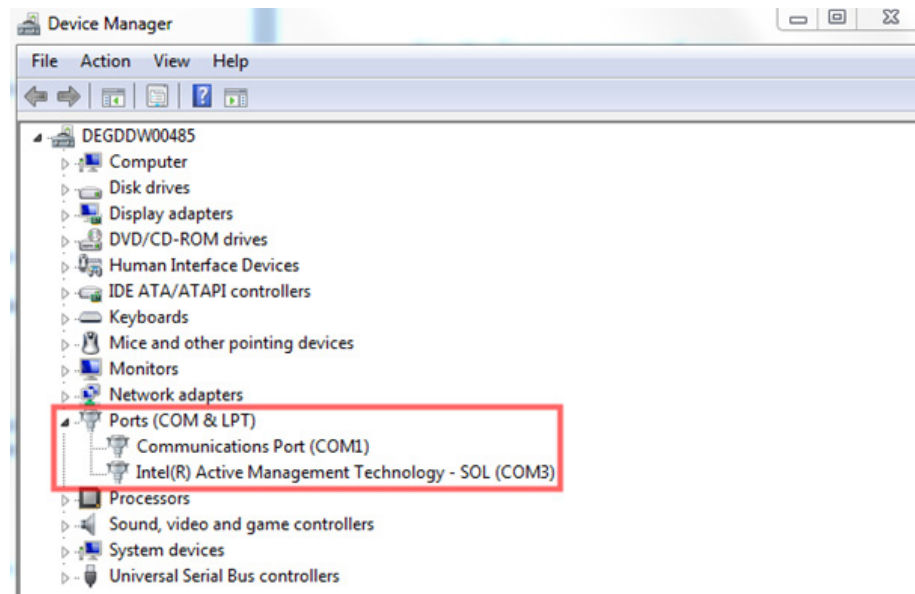

6 Now connect the MCU with the laptop/PC.

A new COM port is shown.

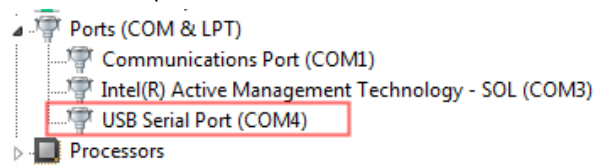

Use this COM port for communication.

### 4.1.4 Connection to the device via Ethernet (option)



The Ethernet interface module (see “Options for MCU control unit”, page 125) must be installed in the MCU (see “Fitting the interface and I/O module (option)”, page 56) and configured (see “Setting the Ethernet module parameters”, page 85) to connect to the measuring system via Ethernet.

Recommended procedure:

- 1 The MCU must be switched off.
- 2 Connect the MCU with the network.
- 3 Connect the PC to the same network.
- 4 Switch the MCU on.
- 5 Start SOPAS ET.
- 6 “Search settings”
- 7 “Device family oriented search”
- 8 Click the desired MCU
- 9 Make the settings:
  - Ethernet communication (always clicked)
  - USB communication (always clicked)
  - Serial communication: Do *not* click
- 10 Specify the IP addresses
  - IP address: see “Setting the Ethernet module parameters”, page 85
- 11 Do not click a COM port
- 12 Assign a name for this search
- 13 “Finish”

## 4.2 Application-specific settings

The measuring system must first be set to the respective internal duct diameter to ensure correct measurement. The following steps are then necessary:

- Focussing the sender light beam  
The light spot on the reflector must lie within the optical active reflection surface under consideration of the active measuring path and the swivel angle allowed.
- Scaling the measuring system to a path free of particles  
Influences on measuring results specific to the device and dependent on the distance must be eliminated. The path free from particles must be identical to the active measuring path (distances between the optical interfaces of the sender/receiver unit and reflector must be the same).

### 4.2.1 Preparatory work

- ▶ Assemble the measuring system away from the measuring location at a dark place with as little dust as possible where voltage supply is available.

There are two options:

- Using the optional adjusting stand (see “Miscellaneous”, page 125)

Fig. 35: Assembly on a dust-free path with adjusting stands (shown for DUSTHUNTER T100)

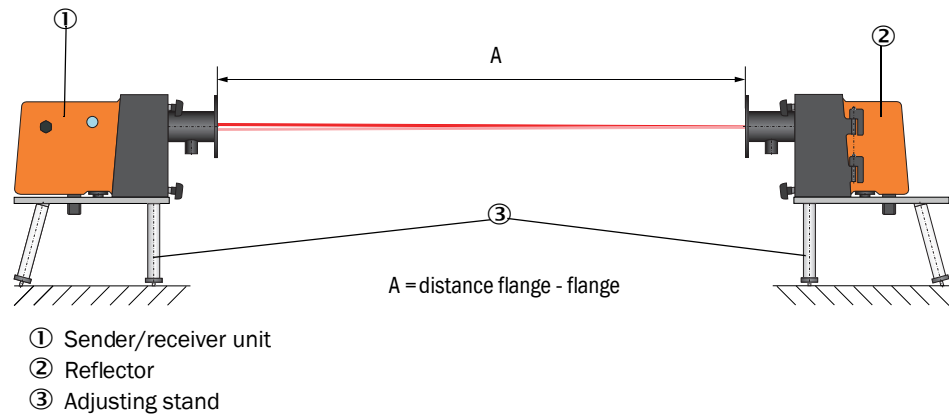

The reflector on DUSTHUNTER T50 must be placed in the bracket of the adjusting stand according to Fig. “Assembly of the DHT-R5x reflector on the adjusting stand”.

Fig. 36: Assembly of the DHT-R5x reflector on the adjusting stand

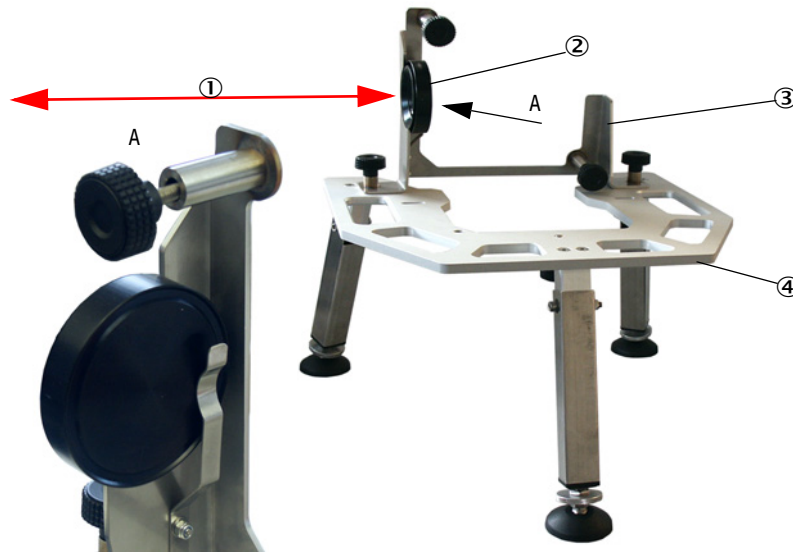

- ① Optical axis
- ② Reflector DHT-R5x
- ③ Bracket for reflector DHT-R5x
- ④ Adjusting stand

- Onsite installation of a “zero tube”.  
The tube must fit on the flange tubes and have little reflection inside.

Fig. 37: Assembly on a dust-free path with zero tube (shown for DUSTHUNTER T100)

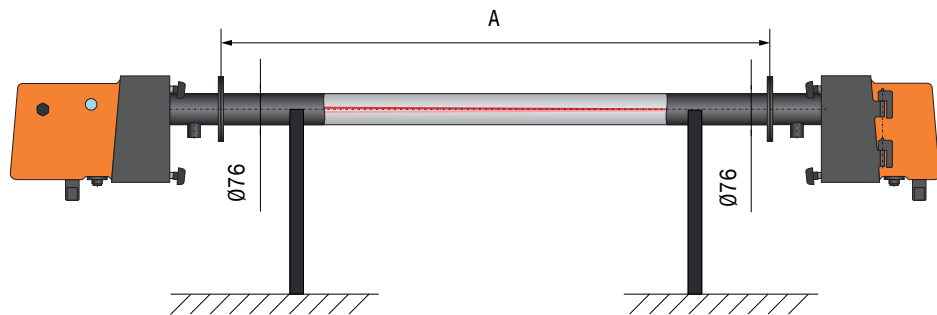

- ▶ Using the associated connection lines, connect the sender/receiver unit to the MCU and also the reflector to the sender/receiver unit for DUSTHUNTER T200.
- ▶ Connect the MCU to the supply voltage.
- ▶ Start the SOPAS ET program and connect to the measuring system (see [“Connection to the device via USB line”](#), page 58).
- ▶ Enter the Level 1 password (see [“Password and operating levels”](#), page 86).
- ▶ Set the sender/receiver unit to “Maintenance”: Click “Maintenance sensor”.

Fig. 38: SOPAS ET menu: DH T100/Maintenance/Maintenance

The screenshot displays two sections of the SOPAS ET menu. The first section, titled "Device identification", contains a dropdown menu set to "DHT100", an empty text input field, and a label "Mounting location" followed by another empty text input field. The second section, titled "Set on operational mode", features two radio button options: "Maintenance" (which is selected) and "Maintenance sensor" (which is unchecked).

- ▶ Clean the optical surfaces on sender/receiver unit and reflector (see [“Maintenance on the sender/receiver unit”](#), page 95 and see [“Maintenance on the reflector”](#), page 98).
- ▶ Wait approx. 30 min before starting the following work (measuring system must have reached operating temperature).

### 4.2.2 Focussing the sender light beam for transmission measurement

- ▶ Select the “Adjustment / Manual Adjustment / Transmission set reference” directory and activate the “Permanent LED light” checkbox in the “Adjustment aids” field.

Fig. 39: SOPAS ET menu: DH T100/Adjustment/Manual Adjustment/Transmission set reference

The screenshot displays the SOPAS ET menu interface for the DH T100. It is divided into several sections:

- Device identification:** Shows 'DH' in a dropdown menu and a 'Mounting location' input field.
- Transmission set reference:** A list of seven steps with associated buttons and radio buttons:
  - Step 1: 'Activate signal adjustment for show justification' button.
  - Step 2: 'Install and align the optical components on dust and smoke free path' text.
  - Step 3: 'Gain adjustment' button and a selected radio button for 'Gain adjustment, set reference value for contamination measurement'.
  - Step 4: 'Cover the reflector with a black material' text.
  - Step 5: 'Background light measurement' button and a selected radio button for 'Background light'.
  - Step 6: 'Remove the black cover and wait min. 3 minutes to get stable measurement values' text.
  - Step 7: 'Set reference' button and a selected radio button for 'Set reference factor measurement'.
- Adjustment aids:** Includes a 'Transmission' input field set to '1.0 %', a 'Permanent LED light' checkbox (unchecked), and a 'Signal adjustment activ' radio button (checked).
- Set reference result:** Displays current values for 'Transmission reference value' (100.0 %), 'Background light' (0.000 V), 'Set reference temperature' (25.0 °C), and 'Set reference factor' (1.00). It also shows 'Sender/receiver unit reference value' (0.000 %) and an 'Update' button.
- Show justification:** A graphical display showing a red square frame with a yellow circle and a green dot at the center, representing the light beam alignment. The axes are labeled 'X 10.000' and 'Y 0.000'.

- ▶ Loosen the CAMLOCK clips on the DUSTHUNTER T50 sender/receiver unit (see “Sender/receiver unit DHT-Txx”, page 17) and remove the electronics unit.
- ▶ For DUSTHUNTER T100/T200, loosen the knurled screws (see “Sender/receiver unit DHT-Txx”, page 17), swivel the electronics unit to the side and remove the pivoted shutter cover (1).
- ▶ Unscrew the cover screw for the focussing opening (2).



Fig. 40: Cover screw for focussing opening (shown for DUSTHUNTER T100/T200)

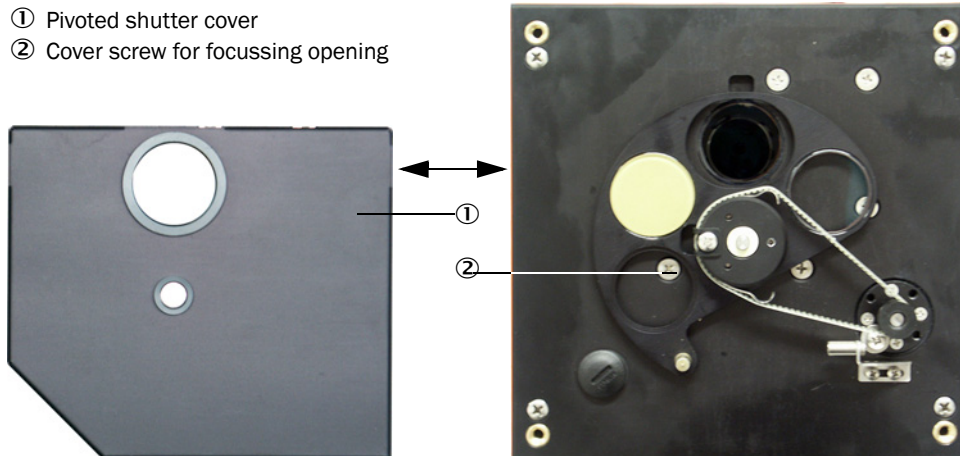

► Insert the screw driver in the focussing opening and set the adjustment screw so that the scale pointer in the control window points to the distance between the optical surfaces of the sender/receiver unit and the reflector.

DUSTHUNTER T50:

Distance = dimension A + 250 mm (Fig. "Assembly on a dust-free path with adjusting stands (shown for DUSTHUNTER T100)")

DUSTHUNTER T100/T200:

Distance = dimension A + 326 mm (Fig. "Assembly on a dust-free path with adjusting stands (shown for DUSTHUNTER T100)")

Fig. 41: Focussing the sender light beam

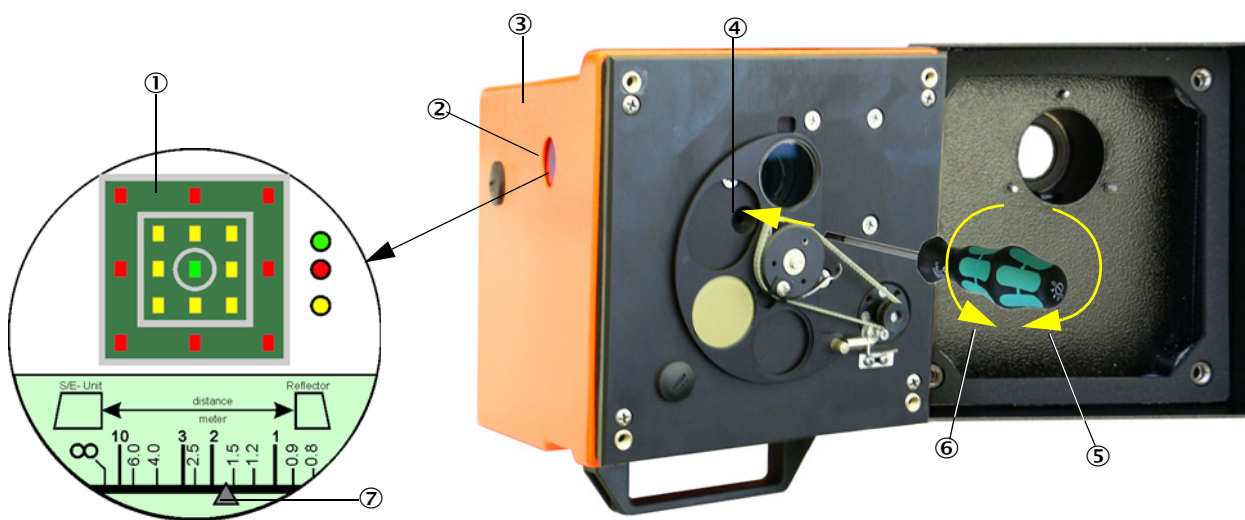

- ① 4-quadrant display
- ② Control window
- ③ Electronics unit

- ④ Focussing opening
- ⑤ Reduce active measuring path
- ⑥ Increase active measuring path

- ⑦ Scale



The scale illumination lights when the measuring system is switched to "Maintenance" or up to 10 min after device reboot.

► Swivel the electronics unit back to measuring position and lock with the knurled screws.

- ▶ For DUSTHUNTER T200, click “Mechanical centring” („Step 1’) in the “Adjustment / Manual Adjustment / Transmission set reference” directory (see [“SOPAS ET menu: DH T100/Adjustment/Manual Adjustment/Transmission set reference”, page 64](#)).
- ▶ Align the optical axes of the sender/receiver unit and reflector to each other. Align the sender/receiver unit so that the sender spot lies on the middle of the opening for the reflector (see [“Reflector”, page 20](#)). Align the reflector so that sender spot (1) can be seen in the circular marking in the middle of the control window (2) on the back of the enclosure (3).

Fig. 42: Sender spot on the back of the enclosure of the reflector

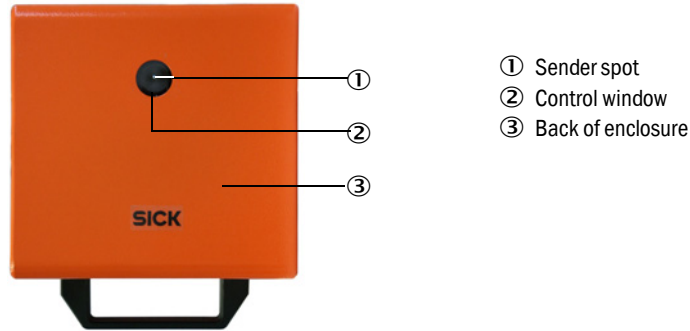

- ▶ Deactivate “Permanent LED light” checkbox (see [“SOPAS ET menu: DH T100/Adjustment/Manual Adjustment/Transmission set reference”, page 64](#)).
- ▶ Check the alignment. The optical axes are aligned exactly when:
  - the green LED in the 4-quadrant display in the control window of the sender/receiver unit lights (see [“Focussing the sender light beam”, page 65](#))
  - for DUSTHUNTER T100/T200, in the “Adjustment / Manual Adjustment / Transmission set reference” directory (see [“SOPAS ET menu: DH T100/Adjustment/Manual Adjustment/Transmission set reference”, page 64](#), see [“SOPAS ET menu: DH T200/Adjustment/Manual Adjustment/Transmission set reference”, page 68](#)), the sender spot (black circular area in the “Show justification” window) is inside the green circle.

A non-exact alignment is signaled by lighting of the LED in the 4-quadrant display in the control window in the following manner:

LED lights	Misalignment of the light spot on the reflector
Green and yellow	Deviation max. approx. 0.1 ° in the shown direction; measured values are valid
Yellow	Deviation max. approx. 0.1 to 0.3 ° in the shown direction; measured values are valid
Yellow and red	Deviation approx. 0.3 ° to 0.4 ° in the shown direction; measured values are valid; possibly larger swivel error than listed in the technical data
Red	Deviation approx. 0.4 ° in the shown direction; measured values are valid; possibly larger swivel error than listed in the technical data
Red LED lights as a circle	Deviation > approx. 0.5 ° or transmission < approx. 10%; dust concentration too high or measuring system incorrectly scaled, self-alignment of DUSTHUNTER T200 no longer possible



On the DUSTHUNTER T200, only rough alignment is necessary because the equipment is fitted with an internal self-alignment. Click the “Optical centering” button in the “Adjustment / Manual Adjustment / Transmission set reference” directory to start automatic fine adjustment (see [“SOPAS ET menu: DH T200/Adjustment/Manual Adjustment/Transmission set reference”, page 68](#)).

The measuring system must then be scaled after focussing has completed.



**NOTE:**

The measuring system must be scaled again after every focus change.

**4.2.3 Scaling the measuring system for transmission measurement**

- ▶ Process successively the steps shown in field “Transmission set reference” in directory “Adjustment / Manual adjustment / Transmission set reference” (see “SOPAS ET menu: DH T100/Adjustment/Manual Adjustment/Transmission set reference”, page 64, see “SOPAS ET menu: DH T50/Adjustment/Manual Adjustment/Transmission set reference”, page 67, see “SOPAS ET menu: DH T200/Adjustment/Manual Adjustment/Transmission set reference”, page 68). While the steps are processed, the associated indicator lights yellow.

Fig. 43: SOPAS ET menu: DH T50/Adjustment/Manual Adjustment/Transmission set reference

The screenshot displays the SOPAS ET menu interface for DH T50, divided into several sections:

- Device identification:** Includes a dropdown menu for 'DH\_T50' and a text input field for 'Mounting location'.
- Transmission set reference:** A list of seven steps:
  - Step 1: 'Activate signal adjustment for show justification' (button)
  - Step 2: 'Install and align the optical components on dust and smoke free path'
  - Step 3: 'Gain adjustment' (button), with a radio button selected for 'Gain adjustment, set reference value for contamination measurement'.
  - Step 4: 'Cover the reflector with a black material'
  - Step 5: 'Background light measurement' (button), with a radio button selected for 'Background light'.
  - Step 6: 'Remove the black cover and wait min. 3 minutes to get stable measurement values'
  - Step 7: 'Set reference' (button), with a radio button selected for 'Set reference factor measurement'.
- Adjustment aids:** Includes a 'Transmission' input field set to '1.0 %', a checkbox for 'Permanent LED light', and a radio button selected for 'Signal adjustment activ'.
- Set reference result:** Displays 'Transmission reference value' as '100 %', 'Background light' as '0.000 V', 'Set reference temperature' as '25 °C', and 'Set reference factor' as '1.00'. An 'Update' button is located at the bottom.
- Show justification:** A graphical display showing a red square frame with a yellow circle centered inside. A green dot is at the center of the circle, and a black dot is to its right. The axes are labeled 'X 10.000' and 'Y 0.000'.

## 4 START-UP AND PARAMETER SETTINGS

Fig. 44: SOPAS ET menu: DH T200/Adjustment/Manual Adjustment/Transmission set reference

**Device identification**

DH T200  Mounting location

**Transmission set reference**

Step 1:  Mechanical centring

Step 2: Install and align the optical components on dust and smoke free path  
 EPA-mode activated

Step 3:  Gain adjustment

Step 4:  Background light measurement

Step 5: Wait to get stable transmission

Step 6:  Set reference

**Adjustment aids**

Transmission  %  
 Optical centring  
 Permanent LED light  Signal adjustment activ

**Set reference result**

Transmission reference value  % Background light  V  
Set reference temperature  °C Set reference factor   
Sender/receiver unit reference value  % Reflector reference value  %

**Show justification**

X 10.000 Y 0.000

- Check whether the value 100% is displayed in window “Transmission reference value” (see “SOPAS ET menu: DH T100/Adjustment/Manual Adjustment/Transmission set reference”, page 64, see “SOPAS ET menu: DH T50/Adjustment/Manual Adjustment/Transmission set reference”, page 67 or Fig. “SOPAS ET menu: DH T200/Adjustment/Manual Adjustment/Transmission set reference”) after this process is completed. When the deviations (< approx. 1%) are small, click the “Set reference” button, when the deviations are large, repeat setting of reference.

4.2.4 Entering application-specific parameters

Fig. 45: SOPAS ET menu: DH T200/Configuration/Application parameter (example)

**System status**

Operation  
  Error  
  Maintenance request  
  Maintenance  
  Function check

**Device identification**

Mounting location   
 DH T100 ▾  

Flange-flange  m ▾

Opt. measuring distance  m ▾

Chimney opening  m ▾

Correction factor

**Concentration calibration coefficients = f(extinction)**

	cc2	cc1	cc0
Concentration (Ext)	<input type="text" value="0"/>	<input type="text" value="1"/>	<input type="text" value="0"/>

**RK\_Gruppe\_LED\_Span2**

Span 2 transmission

**Limit contamination and average**

Limit contamination  ▾  
 Limit warning  %

Average activ

Average Interval  ▾  
 Selection Measure Value  ▾

**EPA Conformity**

EPA-mode activ

## 4 START-UP AND PARAMETER SETTINGS

Group	Input window	Parameter	Remark	
Device identification	Mounting location	Name of the measuring location	Assignment of measuring system to the respective measuring location	
	Flange - flange	Flange distance measured on the duct	For registration (e.g. repeated reference setting on a dust-free path)	
	Opt. measuring distance	Active measuring path	Input required for calculation of relative opacity	
	Chimney opening	Chimney diameter at top end		
	Correction factor	Value	Adaption of relative opacity to geometric dimensions of channel	
Concentration calibration coefficients = f (extinction)	cc2	Quadratic coefficient	Input of regression coefficients determined on extinction basis for measurement of the dust concentration in mg/m <sup>3</sup> (see <a href="#">"Calibration for dust concentration measurement"</a> , page 80).	
	cc1	Linear coefficient		
	cc0	Absolute coefficient		
RK_Gruppe_LED_Span2	Span2 transmission	Activated	The second control value is compared with the reference value during the function check.	Activation and input of reference value possible only when the "EPA Conformity" is activated
		Deactivated	The second control value is not used.	
	Reference value	Transmission value in %	Input of a second control value for the function check (see <a href="#">"Function check"</a> , page 13)	
Limit contamination and average	Limit contamination	Value in %	Determination of a limit value, optionally 40% (default value), 20%, 10%, 6%, 4% When checkbox "EPA Conformity" is activated, limit value 4% is firmly assigned.	
	Limit warning	75% of limit value	Automatic determination depending on the entered limit value	
	Average active	Activated	When the checkbox is activated, an average is created from the values measured in the determined average interval.	
		Deactivated		
	Average Interval	Interval time 1/2/3/4/5/6min	Selection of interval time (6 min for use according to EPA standard)	
Selection Measure Value	Measured variable	Selection of measured variable whose values are to be averaged		
EPA Conformity	EPA-mode active	Activated	For use according to EPA standard	
		Deactivated	No use according to EPA standard	

### 4.3 Sender/receiver unit and reflector

After completion of the tasks described above, the sender/receiver unit and the reflector must be removed from the adjusting stands or zero tube and taken to the measuring location.

#### 4.3.1 Connection to the purge air supply

- ▶ Check whether the purge air supply is available (the flow direction must be correct and the purge air hoses fitted tight on the connections).
- ▶ For purge air supply via the MCU-P control unit or external purge air supply, push the purge air hose on the connections of the sender/receiver unit and the reflector and secure with hose clamps.  
For DUSTHUNTER T50, adapter DN 40 to DN 25 may be required.

#### 4.3.2 Fitting and connecting on the duct

- ▶ Attach the sender/receiver unit and reflector to the flange with tube and secure with the associated assembly kit (see “Assembly parts”, page 124), tighten the self-locking nuts as tight as possible.

Fig. 46: Fitting the sender/receiver unit / reflector on the duct

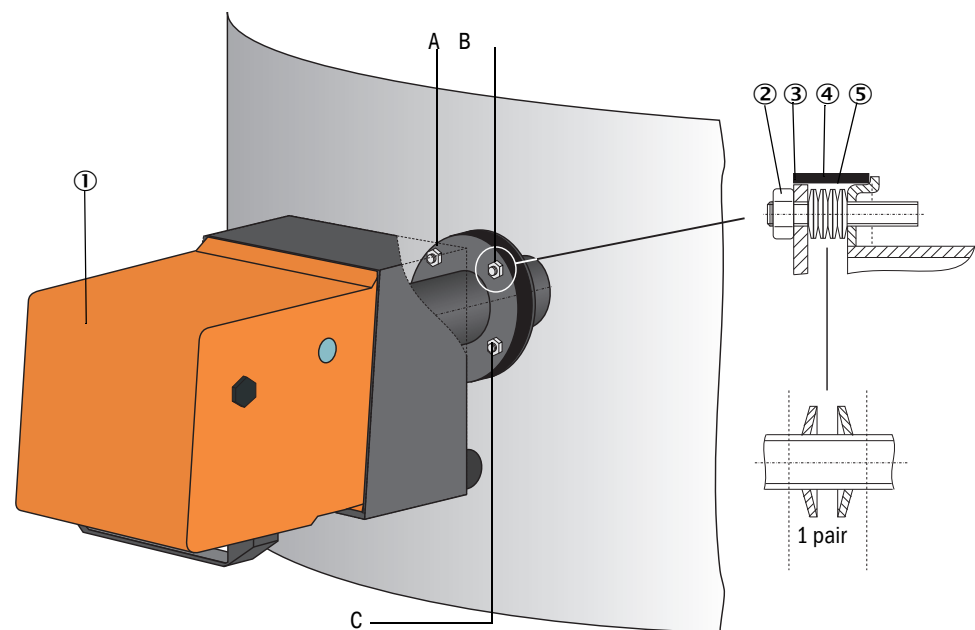

- ① Sender/receiver unit
- ② Self-locking nut
- ③ Spherical washer
- ④ Sealing tape
- ⑤ Cup springs (4 pairs); only with fastening set for sender/receiver unit
- A Horizontal alignment
- B Fixing point
- C Vertical alignment

- ▶ Connect connection line MCU - sender/receiver unit and screw tight; for DUSTHUNTER T200 additionally the line for the connection of sender/receiver unit and reflector (see [“Sender/receiver unit DHT-Txx”](#), page 17, see [“Reflector”](#), page 20).
- ▶ Align optical axis of sender/receiver unit by successive loosening of the self-locking nuts for horizontal and vertical alignment on reflector.  
Alignment is correct when sender spot (1):
  - on DUSTHUNTER T50, is on a semi-transparent foil (2) (possibly also white sheet of paper) in the center of the flange tube of the reflector flange (3);

Fig. 47: Sender spot on reflector side (DUSTHUNTER T50)

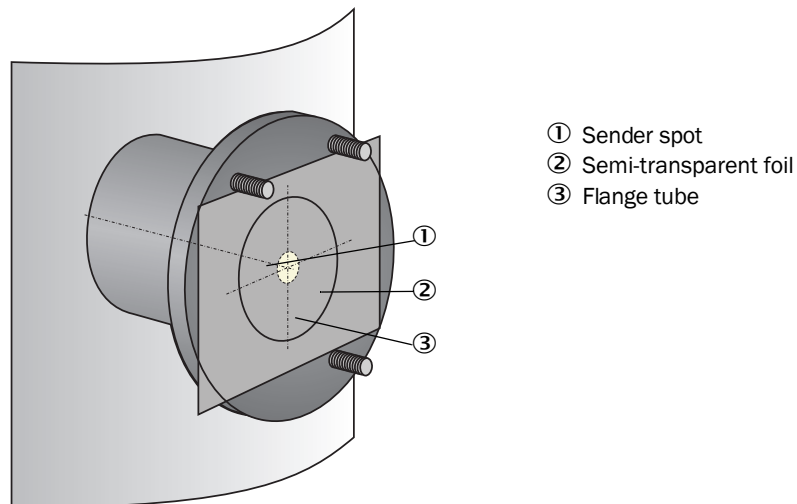

- On DUSTHUNTER T100/T200 located in the center of the control window on the enclosure rear of the reflector (see [“Sender spot on the back of the enclosure of the reflector”](#), page 66).



On DUSTHUNTER T200, the control window on the rear of the reflector is lit for better inspection of the optical alignment in the “Maintenance” mode.



## 4.4 Setting standard parameters

### 4.4.1 Assigning the MCU to the sender/receiver unit

The MCU must be set to the sender/receiver unit to be connected. A malfunction is reported in case of a mismatch. Assignment must be made after installation when the setting is not possible at the factory (e.g., when several devices are delivered at the same time or when the MCU is swapped later). The following steps are then necessary:

- ▶ Connect the measuring system to the SOPAS ET program.
- ▶ Enter the Level 1 password (see [“Password and operating levels”](#), page 86).
- ▶ Set the sender/receiver unit to “Maintenance”: Click “Maintenance sensor”.

Fig. 48: SOPAS ET menu: MCU/Maintenance/Maintenance

The screenshot shows two sections of the SOPAS ET menu. The top section, titled "Device Identification", contains a dropdown menu for "Selected variant" set to "DUSTHUNTER" and a text field for "Mounting Location" set to "SICK". The bottom section, titled "Offline Maintenance", has a checkbox labeled "Activate offline maintenance" which is checked.

- ▶ Change to the “Configuration / Application selection” directory (see [“SOPAS ET menu: MCU/Configuration/Application selection”](#), page 73).
- ▶ The basic type of the sender/receiver unit connected is displayed in the “Connected variant” window (field “Application selection”). Click “Save selection” to assign to the MCU.



The sender/receiver unit must be connected to the MCU.

Fig. 49: SOPAS ET menu: MCU/Configuration/Application selection

The screenshot shows two sections of the SOPAS ET menu. The top section, titled "Device Identification", contains a dropdown menu for "Selected variant" set to "DUSTHUNTER T (T50,T100,T200)" and a text field for "Mounting Location" set to "SICK". The bottom section, titled "Application selection", shows "Connected variant" as "DUSTHUNTER T (T50,T100,T200)" and a "Save selection" button. Below this, a list of "Supported variants" is shown: DUSTHUNTER S (SB50, SB100,SF100,SP100), DUSTHUNTER T (T50,T100,T200), DUSTHUNTER C (C200), FLOWVIC100, FLOWVIC100 - 2 Path, DH\_S+FL100 Combination, DH\_T+FL100 Combination, DH\_C+FL100 Combination, FWE200DH, and Universal.

### 4.4.2 Factory settings

Parameter		Value	
Function check		Every 8 h; output of control values (every 90 s) on standard analog output	
Analog output (AO) [mA]	Live zero (LZ)	4	
	Upper measuring range value (MBE)	20	
	Current during maintenance	0.5	
	Current by malfunction	21 (optional 1)	
Response time		60 s for all measured variables	
Measured variable	Output on AO	Value at LZ	Value at MBE
Transmission [%]		100	0
Opacity [%]	1	0	100
Extinction	3 *	0	2
Dust concentration [mg/m <sup>3</sup> ]	2 *	0	200
Regression coefficients (only for dust concentration)		0.00 / 1.00 / 0.00	

\*: Only when an optional analog module is present (standard on DUSTHUNTER T100 and T200)

The steps required to modify these settings are described in the following Sections. For this purpose, the devices must be connected in SOPAS ET (see [“Connection to the device via USB line”](#), page 58), the Level 1 password set and the “Maintenance” mode set.

4.4.3 Determining the function check

Interval time, control value output on the analog output and the starting timepoint for automatic function check can be modified in the “Adjustment / Function Check - Automatic” directory.

**+i** Default values see “Factory settings”, page 74

Fig. 50: SOPAS ET menu: MCU/Adjustment/Function Check - Automatic (example)

<b>Device Identification</b>		
MCU	Selected variant: DUSTHUNTER	Mounting Location: SICK
<b>Function Check</b>		
Output duration of function control value	90 s	
Function check interval	8 hours	
<b>Function Check Start Time</b>		
Hour	8	Minute: 0

Entry field	Parameter	Remark
Output duration of function control value	Value in seconds	Output duration of control values.
Function check interval	Time between two check cycles	see “Function check”, page 13
Function Check Start Time	Hour	Defining a start timepoint in hours and minutes.
	Minute	

**+i** The value measured last is output during control value determination (see “Function check output on a plotter”, page 13).

### 4.4.4 Setting the analog outputs parameters

Select the “Configuration / IO Configuration / Output Parameters” directory to set the analog outputs.



- Default values see “Factory settings”, page 74
- In order to output the dust concentration under standard conditions (“Conc. s.c.” (Ext)), set the parameters for the analog outputs according to see “Setting the analog inputs parameters”, page 78.

Fig. 51: SOPAS ET menu: MCU/Configuration/IO configuration/Output Parameters

<b>Device Identification</b> MCU <input type="text"/> Selected variant: DUSTHUNTER <input type="text"/> Mounting Location: SICK <input type="text"/>	
<b>Analog Outputs - General Configuration</b> Output Error current: yes <input type="text"/> Error Current: 21 mA <input type="text"/> Current in maintenance: Measured value <input type="text"/> Maintenance current: 0.5 mA <input type="text"/>	
<b>Optional Analog Output Modules</b> Use first analog output module <input type="checkbox"/>	
<b>Analog Output 1 Parameter</b> Value on analog output 1: Conc. a.c. (SL) <input type="text"/> Live zero: 4mA <input type="text"/> Output checkcycle results on the AO <input type="checkbox"/> Write absolute value <input type="checkbox"/>	<b>Analog Output 1 Scaling</b> Range low: 0.00 mg/m <sup>3</sup> <input type="text"/> Range high: 0.00 mg/m <sup>3</sup> <input type="text"/>
<b>Limiting Value</b> Limit value: Conc. a.c. (SL) <input type="text"/> Hysteresis type: <input type="radio"/> Percent <input checked="" type="radio"/> Absolute Switch at: Over Limit <input type="text"/>	<b>Limit Switch Parameters</b> Limit value: 0.00 mg/m <sup>3</sup> <input type="text"/> Hysteresis: 1.00 mg/m <sup>3</sup> <input type="text"/>

Field		Parameter	Remark	
Analog Outputs - General Configuration	Output Error current	Yes	Error current is output.	
		No	Error current is not output.	
	Error Current	Value < Live Zero (LZ) or > 20 mA	mA value to be output in "Malfunction" state (error case) (size depends on connected evaluation system).	
		User defined value	During "Maintenance", the value entered in the "Maintenance current" field is output.	
			Value measured last	The value measured last is output during "Maintenance"
	Measured value output	The current measured value is output during "Maintenance".		
Maintenance current	Whenever possible, value ≠ LZ	mA value to be output in "Maintenance" state		
Optional Analog Output Modules	Use first analog output module	Inactive	Not permitted for DUSTHUNTER T100/T200 (results in error, because AO 2 and AO 3 are available by default).	
		Active	Opens the fields to set parameters for AO 2 and AO 3 (standard on DUSTHUNTER T100 and T200)	
Analog Output 1 Parameter	Value on analog output 1	Concentration a.c. (ext)	Dust concentration under operating conditions (based on extinction)	The selected measured variables are output on the analog output.
		Concentration s.c. (ext)	Dust concentration under standard conditions (based on extinction)	
		Opacity		
		Extinction		
		Transmission		
		Rel. opacity	Relative opacity	
	Live zero	Zero point (0, 2 or 4 mA)	Select 2 or 4 mA to ensure being able to differentiate between measured value and switched off device or interrupted current loop.	
	Output checkcycle results on the AO	Inactive	Control values (see "Function check", page 13) are not output on the analog output.	
		Active	Control values are output on the analog output (the "Output control values at AO" checkbox in the "Adjustment / Function Check - Automatic" directory must be activated).	
	Write absolute value	Inactive	Positive and negative measured values are differentiated.	
Active		The amount of the measured value is output.		
Analog Output 1 Scaling	Range low	Lower measuring range limit	Physical value at live zero	
	Range high	Upper measuring range limit	Physical value at 20 mA	
Limiting Value	Limit value	Concentration a.c. (ext)	Dust concentration under operating conditions (based on extinction)	Select the measured variable for which a limit value is to be monitored.
		Concentration s.c. (ext)	Dust concentration under standard conditions (based on extinction)	
		Opacity		
		Extinction		
		Transmission		
		Rel. opacity	Relative opacity	
	Hysteresis type	Percent	Assignment of the value entered in the "Hysteresis value" field as relative or absolute value of defined limit value	
		Absolute		
Switch at	Value exceeded	Define the switching direction		
	Underflow			
Limit Switch Parameters	Limit value	Value	The limit value relay switches when the value entered is overflown or underflown.	
	Hysteresis	Value	Define a tolerance for resetting the limit value relay	

 Set the parameters for "Analog Output 2(3) Parameter" and "Analog Output 2(3) Scaling" in the same manner as for "Analog Output 1 Parameter" and "Analog Output 1 Scaling".

### 4.4.5 Setting the analog inputs parameters

Select the “Configuration / I/O Configuration / Input Parameters DUSTHUNTER” directory to set the analog inputs.

Fig. 52: SOPAS ET menu: MCU/Configuration/IO configuration/Input Parameters

The screenshot shows the 'Input Parameters' configuration screen. At the top, 'Device Identification' includes a dropdown for 'Selected variant' (DUSTHUNTER) and a text field for 'Mounting Location' (SICK). Below are four columns for sensor sources: Temperature, Pressure, Moisture, and Oxygen. Each column has a radio button to select between 'Constant Value' and 'Analog Input' (1-4). At the bottom, there are four 'Constant' fields with numerical input boxes and units: Constant Temperature (0.00 °C), Constant Pressure (1013.25 mbar), Constant Moisture (0.00 %), and Constant Oxygen (6.00 %).

Field	Parameter	Remark
Temperature Source	Constant Value	A fixed value is used to calculate the scaled value. This parameter opens the “Constant Temperature” field to enter the scaling value in °C (° F for imperial units) or K.
	Analog Input 1	The value from an external sensor connected to analog input 1 (standard scope of delivery) is used to calculate the scaled value. This parameter opens the “Analog input 1 - Temperature” field to set the lower and upper range limit values and the Live Zero value.
Pressure Source	Constant Value	A fixed value is used to calculate the scaled value. This parameter opens the “Constant Pressure” field to enter the scaling value in mbar (= hPa).
	Analog Input 2	The value from an external sensor connected to analog input 2 (standard scope of delivery) is used to calculate the scaled value. This parameter opens the “Analog input 2 - Pressure” field to set the lower and upper range limit values and the Live Zero value.
Moisture Source	Constant Value	A fixed value is used to calculate the scaled value. This parameter opens the “Constant Moisture” field to enter the scaling value in %.
	Analog Input 3	The value from an external sensor connected to analog input 3 (optional module required) is used to calculate the scaled value. This parameter opens the “Analog input 3 - Moisture” field to set the lower and upper range limit values and the Live Zero value.
Oxygen Source	Constant Value	A fixed value is used to calculate the scaled value. This parameter opens the “Constant Oxygen” field to enter the scaling value in %.
	Analog Input 4	The value from an external sensor connected to analog input 4 (optional module required) is used to calculate the scaled value. This parameter opens the “Analog input 4 - Oxygen” field to set the lower and upper range limit values and the Live Zero value.

#### 4.4.6 Setting the response time

Select the “Configuration / Value Damping” directory to set the damping time.

Fig. 53: SOPAS ET menu: MCU/Configuration/Value Damping

Device Identification		
MCU	Selected variant	DUSTHUNTER
	Mounting Location	SICK
Value Damping Time		
Damping time for Sensor 1		60 sec

Field	Parameter	Remark
Damping time for Sensor 1	Value in s	Response time for the selected measured variable (see “Response time”, page 12) Setting range 1 ... 600 s

### 4.4.7 Calibration for dust concentration measurement

For exact dust concentration measurement, the relation between the primary measured variable transmission and the resulting calculated measured variable extinction and the actual dust concentration in the duct must be established. To do this, the dust concentration must be determined based through a gravimetric comparison measurement according to DIN EN 13284-1 and set in relation to the extinction values measured at the same time by the measuring system.



**NOTE:**

Carrying out a gravimetric comparison measurement demands special knowledge that cannot be described in detail here.

**Steps to be carried out**

- ▶ Select device file “MCU”, set the measuring system to “Maintenance” mode
- ▶ Enter the Level 1 password (see “Password and operating levels”, page 86).
- ▶ Select the “Configuration / IO Configuration / Output Parameters” directory (see “SOPAS ET menu: MCU/Configuration/IO configuration/Output Parameters”, page 76) and assign the “Extinction” measured variable to an analog output.
- ▶ Estimate the measuring range required for the dust concentration in operational state and enter this in the “Analog Output 1 (2/3) Scaling” field assigned to the selected analog output for output of the extinction.
- ▶ Deactivate “Maintenance” mode.
- ▶ Carry out the gravimetric comparison measurement according to DIN EN 13284-1.
- ▶ Determine regression coefficients from the mA values of the analog output for “Extinction” and the actual dust concentrations measured gravimetrically.

$$c = K2 \cdot I_{out}^2 + K1 \cdot I_{out} + K0 \tag{1}$$

c: Dust concentration in mg/m<sup>3</sup>  
 K2, K1, K0: Regression coefficients of the function  $c = f(I_{out})$   
 I<sub>out</sub>: Current output value in mA

$$I_{out} = LZ + Ext \cdot \frac{20mA - LZ}{MBE} \tag{2}$$

Ext: Measured extinction  
 LZ: Live Zero  
 MBE: Defined upper range limit value  
 (value entered for 20 mA;  
 normally 2.5 x fixed limit value)

- ▶ Enter the regression coefficients  
 There are two options:
  - Direct input of K2, K1, K0 in a measured value computer.



**NOTICE:**

After calibration, the regression coefficients set in the sender/receiver unit and the measuring range set in the MCU may not be changed anymore.  
 On the LC-Display (option), the dust concentration is shown in mg/m<sup>3</sup> as uncalibrated value.



- Use the regression function of the measuring system (use without measured value computer). In this case, the correlation to the extinction has to be determined. To do this, calculate the regression coefficients cc2, cc1 and cc0 to be entered in the measuring system from K2, K1, K0.

$$c = cc2 \cdot Ext^2 + cc1 \cdot Ext + cc0 \quad (3)$$

Using (2) in (1), the result is as follows:

$$c = K2 \cdot \left( LZ + Ext \cdot \frac{20mA - LZ}{MBE} \right)^2 + K1 \cdot \left( LZ + Ext \cdot \frac{20mA - LZ}{MBE} \right) + K0$$

Using (3), the result is as follows:

$$\begin{aligned} cc0 &= K2 \cdot LZ^2 + K1 \cdot LZ + K0 \\ cc1 &= (2 \cdot K2 \cdot LZ + K1) \cdot \left( \frac{20mA - LZ}{MBE} \right) \\ cc2 &= K2 \cdot \left( \frac{20mA - LZ}{MBE} \right)^2 \end{aligned}$$

Now enter the regression coefficients cc2, cc1 and cc0 determined in directory "Configuration/Application parameters" (see "SOPAS ET menu: DH T200/Configuration/Application parameter (example)", page 69) (set sender/receiver unit to "Maintenance" state and enter the Level 1 password).

Reset the sender/receiver unit back to "Measurement" state afterwards).



This method allows changing the parameters for the selected measuring range as desired.

4.4.8 Data backup in SOPAS ET

All parameters relevant for recording, processing and input/output of measured values as well as current measured values can be saved in SOPAS ET and printed. This allows easy reentering of set device parameters as needed or registering device data and states for diagnostic purposes.

The following options are available:

- Saving as a project  
Not only device parameters but also data logs can be saved.
- Saving as a device file  
Saved parameters can be processed without a device connected and transferred to the device again later.

 Description, see SOPAS ET Help menu and DUSTHUNTER Service Manual.

- Saving as a protocol  
Device data and parameters are registered in the Parameter protocol.  
A Diagnosis protocol can be created for analysis of the device function and recognition of possible malfunctions.

Parameter protocol example

Fig. 54: DUSTHUNTER T Parameter protocol (example)

Type of device: DH T100		Dusthunter - Parameter protocol	
Mounting location:			
<b>Device information</b>		<b>Factory calibration settings</b>	
Device version		<b>Device temperature</b>	
Firmware version		cc2	0.0000
Serial number	00008700	cc1	100.0000
Identity number	00000	cc0	-275.1500
Hardware version	1.2	<b>Power supply</b>	
Firmware bootloader S/R-unit	V00.99.15	cc2	0.0000
<b>Installation parameter</b>		cc1	11.0000
Bus address	1	cc0	0.0000
Flange-flange	1.00m	<b>Temp. correction transmission</b>	
Opt. measuring distance	1.00m	cc2	0.0000
Chimney opening	1.00m	cc1	0.0000
Correction factor	1.000	cc0	0.0000
<b>Concentration calibration coefficients = f(Extinction)</b>		<b>Pivot correction factors</b>	
cc2	0.0000	Corr_mx(-X)	aktiv
cc1	1.0000	cc4	0.000000
cc0	0.0000	cc3	0.000000
Limit contamination warning	20.0%	cc2	0.000000
Limit contamination fault	30.0%	cc1	0.000000
Average	inaktiv	cc0	0.000000
Average interval	1 min	Corr_px(+X)	aktiv
Selection Measure Value	Opacity	cc4	0.000000
EPA-mode	inaktiv	cc3	0.000000
<b>Device parameter</b>		cc2	0.000000
<b>Factory settings</b>		cc1	0.000000
Response time sensor	1.0s	cc0	0.000000
Response time diagnosis values	10.0s	Corr_my(-Y)	aktiv
Delay ADC-trigger LED	32µs	cc4	0.000000
Response time contamination	5	cc3	0.000000
Pivoted shutter at S/R-unit in contamination measurement position	51	cc2	0.000000
Pivoted shutter at S/R-unit in check point measurement position	102	cc1	0.000000
		cc0	0.000000
		Corr_py(+Y)	aktiv
		cc4	0.000000
		cc3	0.000000
		cc2	0.000000
		cc1	0.000000
		cc0	0.000000

#### 4.4.9 Starting measurement mode

Set the measuring system to “Measurement” mode after entering/modifying parameters. To do so, cancel “Maintenance”: Deselect “Maintenance sensor”.

Fig. 55: SOPAS ET menu: MCU/Maintenance/Maintenance

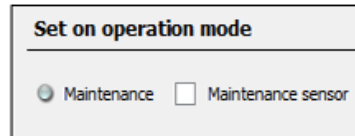

Standard start-up is now completed.

4.5 Setting the Interface module parameters

4.5.1 General information

The following steps are necessary to select and set the optionally available Interface modules Profibus DP, Modbus TCP and Ethernet type 1:1

- ▶ Select device file “MCU”, set the measuring system to “Maintenance” mode
- ▶ Enter the Level 1 password (see “Password and operating levels”, page 86).
- ▶ Switch to the “Configuration / System Configuration” directory.  
The installed interface module is displayed in the field “Interface Module”.
- ▶ Configure the Interface module according to requirements.

Fig. 56: SOPAS ET menu: MCU/Configuration/System Configuration

**Device Identification**

MCU Selected variant DUSTHUNTER S (SB50, SB100,SF100,SP100) Mounting Location SICK

---

**Interface Module**

Interface Module No Module ▾

No Module

Profibus

Ethernet

RS 485

---

**Current Time**

Date/Time

---

**Adjust Date/Time**

Day  Month  Year

Hour  Minute  Second

Date / Time set  Invalid value

---

**System Time Synchronization**

Date / Time: Thursday, October 1, 2015 9:58:24 AM CEST

---

**Settings for service interface**

Protocol selection CoLa-B ▾ Modbus Address  Serial service port baudrate

Use RTS/CTS lines



GSD file and measured value assignment are available for the Profibus DP module on request.

## 4.5.2 Setting the Ethernet module parameters



### NOTICE:

The risk of undesired access to the measuring system is inherent when communicating via Ethernet.

- ▶ Operate the measuring system only behind suitable protection (e.g., Firewall).



The configuration of interface module Ethernet type 2 (see “Options for MCU control unit”, page 125) is not possible with program SOPAS ET. A special software with description is supplied with the program.

Standard setting: 192.168.0.10

A predefined IP address is set on request.

To change the settings:

- ▶ Select directory “Configuration / I/O Configuration / Interface Module”.
- ▶ Set the desired network configuration in the “Expansion module information” field and click “Reset module”.

Fig. 57: SOPAS ET menu: MCU/Configuration/I/O configuration/Interface Module

**Expansion module information**

---

Module type: No module found ▼

Reset module    When this button is clicked, the connection will be reseted

**Ethernet Interface Configuration**

---

IP Address    192    168    0    10

Subnet mask    255    255    255    0

Gateway    0    0    0    0

TCP port    2111

4.6 Operating/setting parameters via the optional LC-Display

4.6.1 General information on use

The display and operating interface of the LC-Display contains the functional elements shown in Fig. "LC-Display functional elements".

Fig. 58: LC-Display functional elements

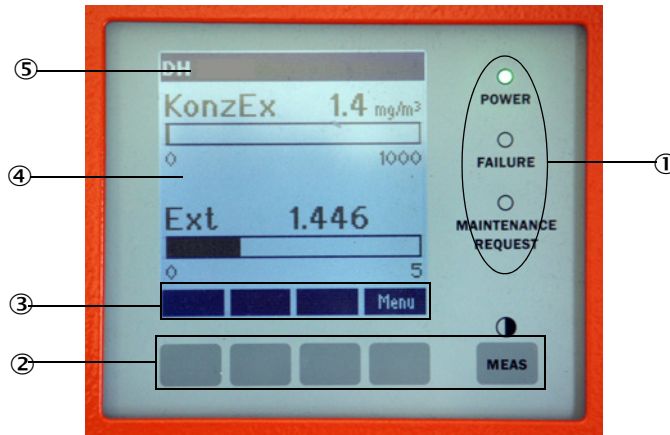

- ① Status LED
- ② Control buttons
- ③ Current button function
- ④ Display field
- ⑤ Status bar

Button functions

The function shown depends on the Menu currently selected. Only the function shown in the button is available.

Button	Function
Diag	Display diagnostic information (warnings and errors during a start using the Main menu, sensor information during a start using the Diagnostics menu)
Back	Switch to higher level menu
Arrow ↑	Scroll up
Arrow ↓	Scroll down
Enter	Execution of the action selected with an arrow button (switch to a submenu, confirm parameter selected during parameter setting)
Start	Start an action
Save	Store a changed parameter
Meas	Switch from main measured values to measured sensor values Display the contrast setting (after 2.5 s)

4.6.2 Password and operating levels

Certain device functions are first accessible after a password has been entered.

User level	Access to
0 Operator	Displays measured values and system states No password required
1 Authorized operator	Displays, inquiries as well as start-up or adjustment to customer-specific demands and diagnosis of necessary parameters Preset password: 1234

4.6.3 Menu structure

Fig. 59: LC-Display menu structure

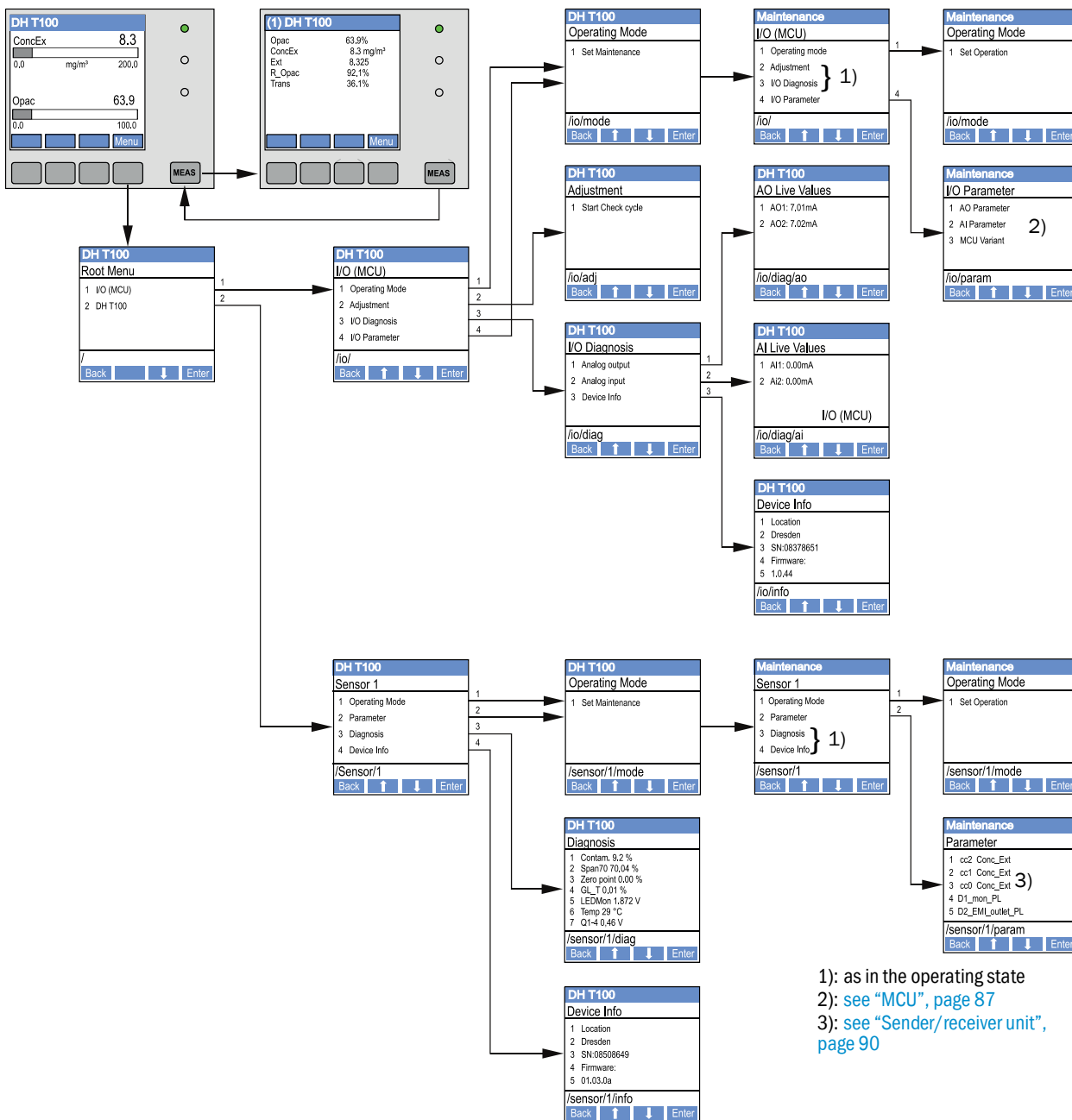

1): as in the operating state  
 2): see "MCU", page 87  
 3): see "Sender/receiver unit", page 90

4.6.4 Configuration

4.6.4.1 MCU

Analog outputs / inputs

- ▶ Set the MCU to "Maintenance" mode and select the "I/O Parameter" submenu.
- ▶ Select the desired parameter and enter the default password "1234" using the "∧" (scrolls from 0 to 9) and/or "→" (moves the cursor to the right) buttons.
- ▶ Select the desired value using the "∧" and/or "→" buttons and write it to the device with "Save" (confirm 2x).

Fig. 60: Menu structure for configuring analog outputs / inputs and setting the MCU variant

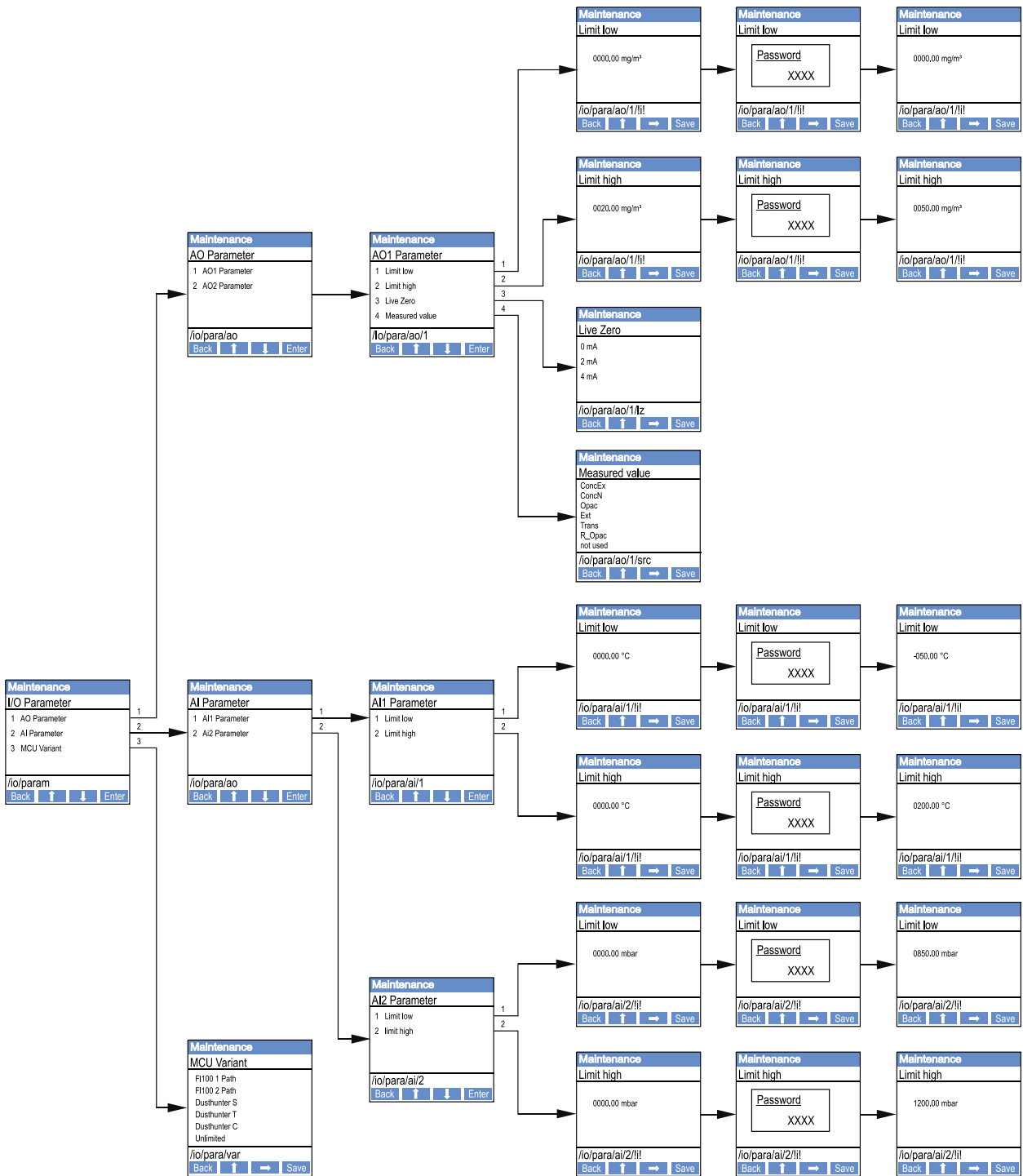



**Setting the MCU variant**

The following steps are required to set the MCU for the DUSTHUNTER T50, T100 or T200 sender/receiver unit to be connected (see [“Assigning the MCU to the sender/receiver unit”, page 73](#)):

- ▶ Set the MCU to “Maintenance” mode, select the “MCU Variant” submenu and select the type “DUSTHUNTER T”.
- ▶ Enter the default password and store the type with “Save” (confirm twice).

The other selection options have no significance here.

## 4.6.4.2 Sender/receiver unit

The following steps are required to enter the regression coefficients:

- ▶ Set the sender/receiver unit to “Maintenance” and select the “Parameter” submenu.
- ▶ Select the desired parameter and enter the password (see “Password and operating levels”, page 86).
- ▶ Set the calculated coefficients (see “Calibration for dust concentration measurement”, page 80) using the “^” and/or “→” buttons and write to the device with “Save” (confirm twice).

Fig. 61: Entering the regression coefficients



D1\_mon\_PL: Active measuring path length in m (→ page 11, §2.1.1)  
 D2\_EMI\_outlet\_PL: Inner stack diameter in m at the top end

4.6.5 Using SOPAS ET to modify display settings

To modify the factory settings, connect SOPAS ET with the “MCU” (see “Connection to the device via USB line”, page 58), enter the Level 1 password and select the “Configuration / Display Settings” directory.

Fig. 62: SOPAS ET menu: MCU/Configuration/Display Settings

**Device Identification**

MCU Selected variant DUSTHUNTER Mounting Location SICK

**Common Display Settings**

Display language English Display Unit System metric

**Overview Screen Settings**

Bar 1	Sensor 1	Value Value 1	Use AO scaling <input type="checkbox"/>	Range low -100	Range high 1000
Bar 2	MCU	Value Value 1	Use AO scaling <input type="checkbox"/>	Range low -100	Range high 1000
Bar 3	Not Used	Value Value 1	Use AO scaling <input type="checkbox"/>	Range low -100	Range high 1000
Bar 4	Not Used	Value Value 1	Use AO scaling <input type="checkbox"/>	Range low -100	Range high 1000
Bar 5	Not Used	Value Value 1	Use AO scaling <input type="checkbox"/>	Range low -100	Range high 1000
Bar 6	Not Used	Value Value 1	Use AO scaling <input type="checkbox"/>	Range low -100	Range high 1000
Bar 7	Not Used	Value Value 1	Use AO scaling <input type="checkbox"/>	Range low -100	Range high 1000
Bar 8	Not Used	Value Value 1	Use AO scaling <input type="checkbox"/>	Range low -100	Range high 1000

**Measured Value Description**

<p><b>Dusthunter S</b></p> <p>Value 1 = not used                      Value 2 = Concentration a.c. (SL)                      Value 3 = not used                      Value 4 = not used                      Value 5 = not used                      Value 6 = not used                      Value 7 = Scattered Light                      Value 8 = not used</p>	<p><b>Calculated values (MCU)</b></p> <p>Value 1 = Concentration s.c. dry O2 corr. (SL)                      Value 2 = not used                      Value 3 = not used                      Value 4 = not used                      Value 5 = Temperature                      Value 6 = Pressure                      Value 7 = Moisture                      Value 8 = Oxygen</p>
--	--

**Security settings**

Authorized operator 1234 Idle time 30 Minutes

Window	Entry field	Significance
Common Display Settings	Display language	Language version shown on the LC-Display
	Display Unit System	Unit of measurement system used in displays
Overview Screen Settings	Bars 1 to 8	Number of measured value for the first measured value bar in the graphic display
	Value	Measured value index for the respective measured value bar
	Use AO scaling	When activated, the measured value bar is scaled to the associated analog output. If not activated, define the limit values separately
	Range low	Values for separate scaling of the measured value bar independent of the analog output
	Range high	
Security settings	Authorized operator	Password input for the Display menu operating level "Authorized Operator" Default: 1234
	Idle time	Time until user level "Authorized Operator" is automatically switched off again.

### Measured value assignment

MCU measured value	Sender/receiver unit measured value
Value 1	Opacity
Value 2	Not used
Value 3	Concentration a.c.
Value 4	Extinction
Value 5	Rel. opacity
Value 6	Transmission
Value 7	Not used
Value 8	Not used
MCU Value 2	Concentration s.c.

## 5 Maintenance

### 5.1 General

The maintenance work to be carried out consists of:

- Cleaning work (see “Maintenance on the sender/receiver unit and reflector”, page 95),
- Securing the purge air supply function (see “Cleaning the optical interfaces on the reflector”, page 99),
- Checking/correcting the alignment of the optical axes of sender/receiver unit and reflector (see “Focussing the sender light beam for transmission measurement”, page 64).

Take the following steps to set the measuring system to “Maintenance” mode before starting maintenance work.

- ▶ Connect the MCU to the laptop/PC using the USB line and start program SOPAS ET.
- ▶ Connect with the MCU (see “Connection to the device via USB line”, page 58).
- ▶ Enter the Level 1 password (see “Password and operating levels”, page 86).
- ▶ Set the sender/receiver unit to “Maintenance”: Click “Maintenance sensor”

Fig. 63: SOPAS ET menu: MCU/Maintenance/Maintenance

The screenshot shows a software interface with two main sections. The top section is titled "Device Identification" and contains three input fields: "MCU" (a text box), "Selected variant" (a dropdown menu showing "DUSTHUNTER"), and "Mounting Location" (a text box showing "SICK"). The bottom section is titled "Offline Maintenance" and contains a single checkbox labeled "Activate offline maintenance" which is checked.



#### WARNING:

Observe the relevant safety regulations as well as the safety notices (see “Responsibility of user”, page 9) during all work.

#### Resuming measuring operation

Resume measuring operation after completing the work (deactivate the “Maintenance on/off” checkbox in the “Maintenance / Operation” window and click “Set State”).



- “Maintenance” mode can also be set using the buttons on the display on the MCU (see “Menu structure”, page 87) when the LC-Display option is present or by connecting an external maintenance switch to the terminals for Dig In2 (17, 18) in the MCU (see “Connecting the MCU control unit”, page 50).
- An automatic function check is not carried out during “Maintenance”.
- On DUSTHUNTER T200, the control window on the rear of the reflector (see “Sender spot on reflector side (DUSTHUNTER T50)”, page 72) is lit for better inspection of the optical alignment in the “Maintenance” mode.
- The value set for “Maintenance” is output on the analog output (see “Setting the analog outputs parameters”, page 76). This is also applicable when a malfunction is present (signaled on relay output).
- The “Maintenance” mode is reset when there is a voltage failure. In this case, the measuring system switches automatically to “Measurement” after the operating voltage is switched on again.

### **Maintenance intervals**

The equipment operator must specify the maintenance intervals. The period depends on existing operating parameters such as dust content and state, gas temperature, how the equipment is run and ambient conditions. Therefore only general recommendations can be made here. Normally, the maintenance intervals are about 4 weeks during the initial period and can be steadily incremented to up to a year depending on the respective conditions.

The equipment operator must specify the specific work to be carried out and its performance in a Maintenance Manual.

### **Maintenance contract**

Scheduled maintenance work can be carried out by the equipment operator. Only qualified personnel according to Section 1 should be allowed to do the work. If requested, all maintenance activities can also be performed by SICK Service or an authorized Service partner. Any repairs will be made by specialists onsite whenever possible.

### **Auxiliary means required**

- Brush, cleaning cloth, cotton swabs
- Water
- Replacement air filter, preliminary filter (for suction)

## 5.2 Maintenance on the sender/receiver unit and reflector



**NOTE:**

- ▶ Do not damage any device parts during maintenance work.
- ▶ Do not interrupt the purge air supply.

Clean the outside of the sender/receiver unit and reflector in regular intervals. Remove deposits with water or mechanically using suitable auxiliary means.

Clean the optical interfaces when deposits can be seen or maximum contamination allowed has been reached. Limit values are:

DUSTHUNTER T100: 20% for warning, 30% for failure

DUSTHUNTER T200: 30% for warning, 40% for failure



Contamination measurement depends on the type.

### 5.2.1 Maintenance on the sender/receiver unit

#### DUSTHUNTER T50

- ▶ Set the measuring system to “Maintenance” mode (see “General”, page 93).
- ▶ Loosen CAMLOCK clips of the sender/receiver unit (see “Sender/receiver unit DHT-Txx”, page 17) and remove the electronics unit from the mounting attachment.
- ▶ Carefully clean glass pane with an optics cloth.
- ▶ Fasten the sender/receiver unit again.
- ▶ Resume Measuring mode.

#### DUSTHUNTER T100 and T200

- ▶ Set the sender/receiver unit to “Maintenance” mode (see “SOPAS ET menu: DH T100/Maintenance/Maintenance”, page 63) and enter the Level 1 password.
- ▶ Loosen the knurled screws and swivel the enclosure to the side.
- ▶ Close the mounting flange with cover (see “Miscellaneous”, page 125).
- ▶ Switch to the “Adjustment / Manual adjustment / Motor control” directory and click “Mounting” under “Pivoted shutter sender/receiver”.  
The pivoted shutter then moves to the cleaning position.

Fig. 64: SOPAS ET menu: DH T100/Adjustment/Manual Adjustment/Motor control



- ▶ Remove pivoted shutter cover (1), press tension spring (7) together and take pivoted shutter (3) off axis (6).
- ▶ Carefully clean glass pane (5) (both sides), zero point reflector (2) and sender optics (4) with an optics cloth.

Fig. 65: Cleaning the optical interfaces on the sender/receiver unit

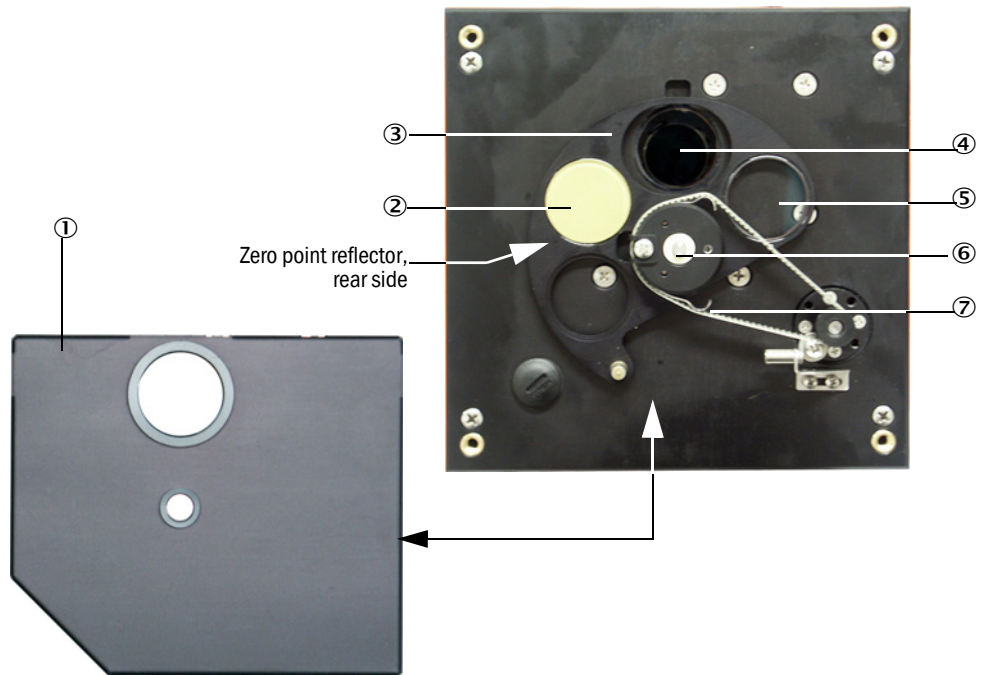

- ① Pivoted shutter cover
- ② Zero point reflector
- ③ Pivoted shutter
- ④ Sender optics
- ⑤ Glass pane (both sides)
- ⑥ Axis
- ⑦ Tension spring

- ▶ Lay the toothed belt on the drive axis, press the tension spring together and push pivoted shutter back onto the axis.
- ▶ To start the function check, connect to file “MCU”, select subdirectory “Adjustment / Manual function check” and actuate “Start Manual Function Check”.

Fig. 66: SOPAS ET menu: MCU/Adjustment/Function Check - Manual

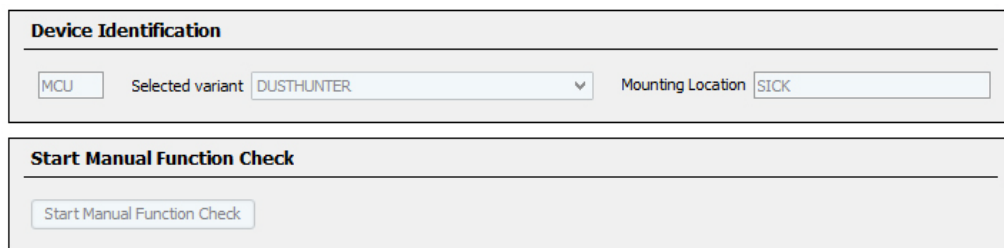

The function check can also be triggered via the LC-Display on the MCU (see “Menu structure”, page 87).

- ▶ In SOPAS ET, connect to device file “DH T100” or “DH T200”, select directory “Diagnosis / Check values” and check the contamination value.



Fig. 67: SOPAS ET menu: DH T100/Diagnosis/Check values

Device identification	
DH T100	Mounting location
Check values	
sender/receiver unit reference value	0.0 %
Background light	0.000 V
Set reference temperature	25.0 °C
Contamination	0.0 %
Span	0.0 %
Zero point	0.0 %
Update values	

- ▶ If the measured values for contamination, zero point and span are within the allowed ranges, save them to the device by clicking the “Refresh” button (“Check values” field); if not, repeat cleaning and check the contamination value again by triggering a renewed function check.



- The contamination value can also be displayed on the LC display of the MCU (initiate a function check and select the “T100/Diagnosis” or “T200/Diagnosis” menu, see “Menu structure”, page 87).
- If the contamination value does not sink below the value for warning in spite of several cleaning processes, check the glass pane for damage and the pivoted shutter for correct positioning. If no malfunction can be detected, contact SICK Service.

- ▶ Put the pivoted shutter cover back on, remove the cover from the assembly flange, swivel the enclosure back in and lock with the knurled screws.
- ▶ Move the pivoted shutter back into the measuring position. To do this, click the “Measurement” button in the “Adjustment / Manual adjustment / Motor control” directory (see “SOPAS ET menu: DH T200/Adjustment/Manual Adjustment/Motor control”, page 99) .
- ▶ Resume Measuring mode.

### 5.2.2 Maintenance on the reflector

#### DUSTHUNTER T50

- ▶ Set the measuring system to “Maintenance” mode (see “General”, page 93).
- ▶ Loosen the CAMLOCK clips of reflector (1) and remove reflector (2).
- ▶ Press purge air pipe (3) with flat screwdriver out of enclosure (4) and remove.

Fig. 68: Reflector DHT-R5x



- ① CAMLOCK clips
- ② Reflector
- ③ Purge air pipe
- ④ Enclosure

- ▶ Carefully clean glass pane with an optics cloth.
- ▶ Push the purge air pipe into the enclosure again and ensure central alignment.
- ▶ Put on the reflector and fasten with CAMLOCK clips
- ▶ Resume Measuring mode.

#### DUSTHUNTER T100

- ▶ Set the measuring system to “Maintenance” mode.
- ▶ Loosen the knurled screws and swivel the enclosure to the side.
- ▶ Close the mounting flange with cover (see “Miscellaneous”, page 125).
- ▶ Carefully clean glass pane with an optics cloth.
- ▶ Remove the cover from the mounting flange, swivel the enclosure back and lock with the knurled screws.
- ▶ Resume Measuring mode.

**DUSTHUNTER T200**

- ▶ Set the sender/receiver unit to “Maintenance” mode (see “Cleaning the optical interfaces on the reflector”, page 99) and enter the Level 1 password.
- ▶ Loosen the knurled screws and swivel the enclosure to the side.
- ▶ Close the mounting flange with cover (see “Miscellaneous”, page 125).
- ▶ Click the “Mounting” button in menu “DH T200/Adjustment/Manual Adjustment/Motor control” under position Pivoted shutter reflector” (see “SOPAS ET menu: DH T200/Adjustment/Manual Adjustment/Motor control”, page 99).  
The pivoted shutter then moves to the cleaning position.

Fig. 69: SOPAS ET menu: DH T200/Adjustment/Manual Adjustment/Motor control

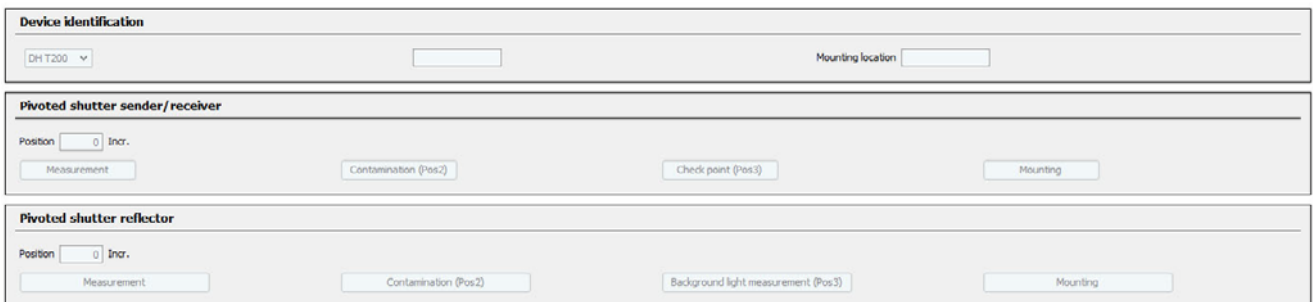

- ▶ Remove pivoted shutter cover (1), loosen tension spring (6) and take pivoted shutter (2) off axis (5).
- ▶ Carefully clean glass pane (4) (both sides) and reflector optics (3) with an optics cloth.

Fig. 70: Cleaning the optical interfaces on the reflector

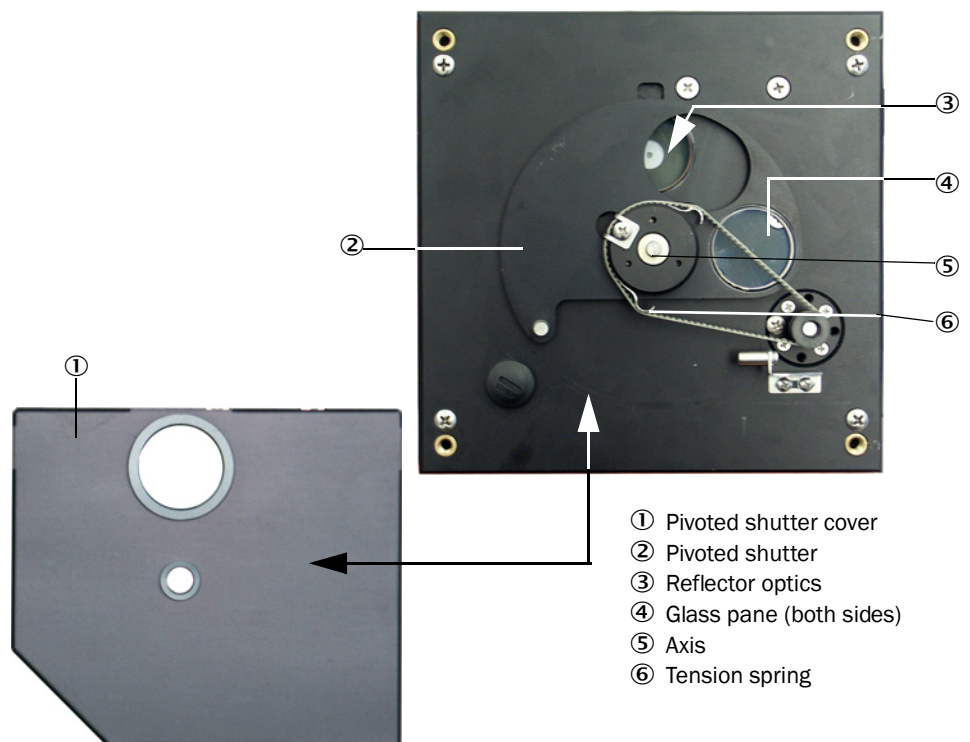

- ▶ Lay the toothed belt on the drive axis, push pivoted shutter back onto the axis and reinstall the tension spring.
- ▶ Trigger the function check (select the “Adjustment / Function Check - Manual” subdirectory in the “MCU” device file and click “Start Manual Function Check”; see [“DUSTHUNTER T Parameter protocol \(example\)”](#), page 82).
- ▶ In SOPAS ET, connect with “DH T200”, select the “Diagnosis / Check values” directory and check the contamination value.

Fig. 71: SOPAS ET menu: DH T200/Diagnosis/Check values

**Device identification**

DH T200  Mounting location

---

**Check values**

sender/receiver unit reference value  %

Reflector reference value  %

Background light  V

Set reference temperature  °C ▾

---

Contamination  %    Contamination sender/receiver unit  %    Contamination reflector  %

Span  %

Zero point  %

- ▶ If the measured values for contamination, zero point and span are within the allowed ranges, save them to the device by clicking the “Refresh” button (“Check values” field); if not, repeat cleaning and check the contamination value again by triggering a renewed function check.

**+i**

- The contamination value can also be displayed on the LD display of the MCU (trigger a function check and select the “T200/Diagnosis” menu, see [“Menu structure”](#), page 87).
- If the contamination value does not sink below the value for warning in spite of several cleaning processes, the device is probably defective → contact SICK Service.

- ▶ Put the pivoted shutter cover back on, remove the cover from the assembly flange, swivel the enclosure back in and lock with the knurled screws.
- ▶ Move the pivoted shutter back into the measuring position. To do this, click the “Measurement” button under “Pivoted shutter reflector” in the “Adjustment / Manual adjustment / Motor control” directory (see [“SOPAS ET menu: DH T200/Adjustment/Manual Adjustment/Motor control”](#), page 99).
- ▶ Resume Measuring mode.

### 5.3 Maintenance on the purge air supply

Maintenance work to be carried out:

- Inspecting the entire purge air supply
- Cleaning the filter housing
- Replacing the filter element, if necessary.

The dust load and wear on the filter element depend on the degree of contamination of the intake ambient air. It is therefore not possible to specify precise time intervals for these tasks. We recommend inspecting the purge air supply at short intervals (approx. 2 weeks) and then optimizing maintenance intervals over a longer period of operation.

**NOTE:**

Irregular or insufficient maintenance of the purge air supply can cause it to fail and thus cause severe damage to the sender/receiver unit.

- ▶ Always ensure purge air supply when the optical components sender/receiver unit and reflector are fitted on the duct.
- ▶ Disassemble the connected components before exchanging damaged purge air hoses (see “Shutdown”, page 104).

**Inspection**

- ▶ Check the running noise of the blower at regular intervals; increases in the noise level can indicate a blower failure.
- ▶ Check that all hoses are secure and free of damage.
- ▶ Check the filter element for contamination.
- ▶ Exchange the filter element when:
  - Severe contamination (deposits on the filter surface) is visible
  - The purge air volume is reduced considerably as compared to operation with a new filter.



The purge air supply does not have to be switched off to clean the filter housing or to replace the filter element, i.e. the components can remain on the duct.

### 5.3.1 Control unit MCU with integrated purge air supply

#### Cleaning or replacing the filter element

- ▶ Open the door of the MCU with the appropriate key.
- ▶ Loosen strap retainer (1) on the filter outlet and pull filter housing (2) off the connection piece.
- ▶ Remove the filter housing.
- ▶ Rotate filter housing cover (3) in the “OPEN” arrow direction and remove the cover.
- ▶ Take out the filter element and replace with a new element.
- ▶ Clean the inside of the filter housing and the filter housing cover with a cloth and brush.



#### NOTICE:

- ▶ For wet cleaning, use only a water-soaked cloth and then dry the parts well.

- ▶ Insert new filter element.  
*Spare part: Filter element C1140, Part No. 7047560*
- ▶ Mount the cover on the filter housing cover and rotate opposite to the direction of the arrow until it clicks into place.
- ▶ Reinstall the filter housing in the control unit.

Fig. 72: Exchanging the filter element for the control unit with purge air supply

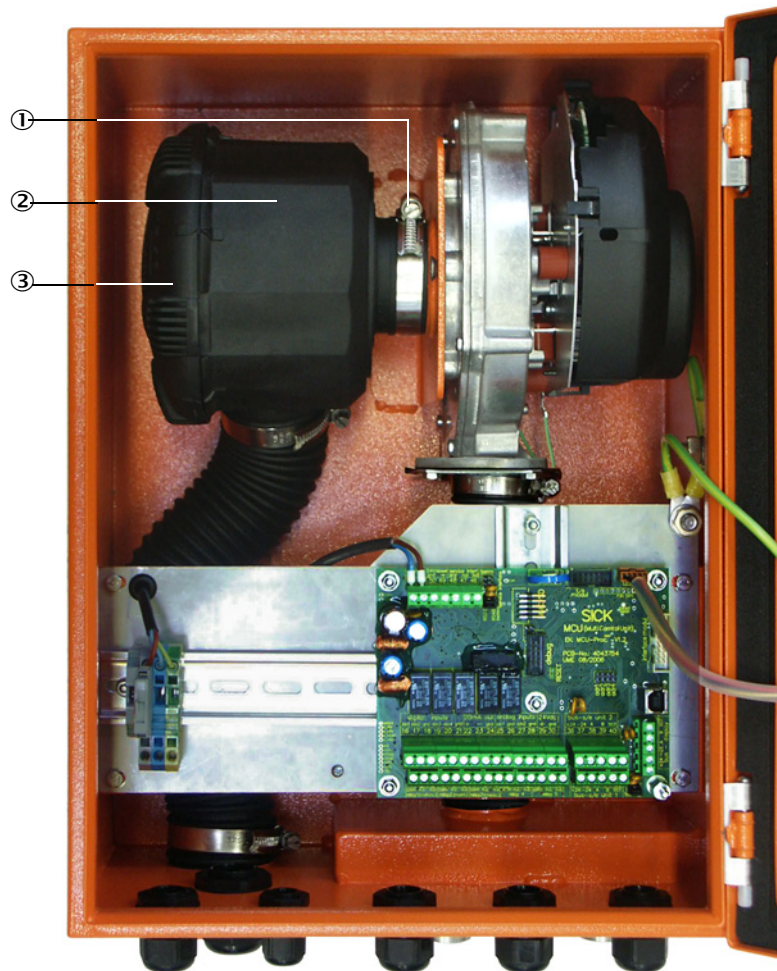

- ① Strap retainer
- ② Filter housing
- ③ Filter housing cover

5.3.2 Optional external purge air unit



**NOTICE:**

The purge air unit must be serviced at the latest when the low-pressure monitor (7) at the filter outlet triggers (see "Replacing the filter element", page 103).

**Replacing the filter element**

Fig. 73: Replacing the filter element

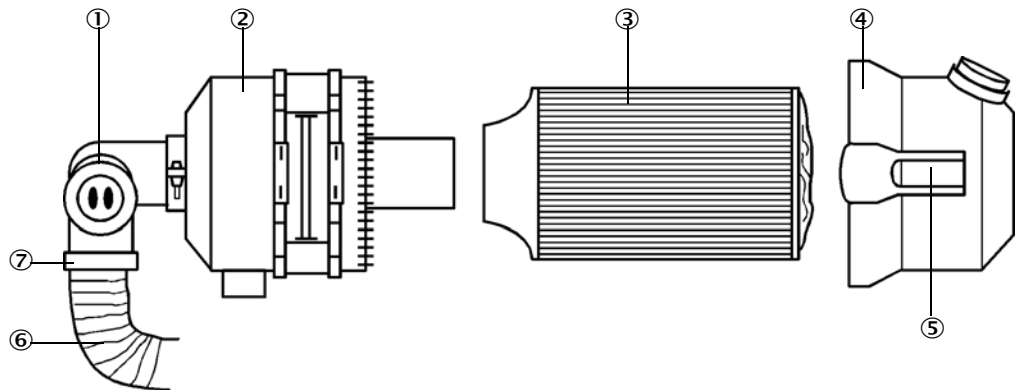

- ① Low-pressure monitor
- ② Filter housing
- ③ Filter element
- ④ Filter housing cover
- ⑤ Snap lock
- ⑥ Purge air hose
- ⑦ Strap retainer

- ▶ Switch the fan off for a short time.
- ▶ Clean outside of filter housing (2).
- ▶ Loosen strap retainer (7) and clamp purge air hose (6) to a clean location.



**NOTICE:**

- ▶ Place the end of the hose in a safe place so that foreign objects cannot be sucked in (this will cause irreparable damage to the blower), but do not close the end of the hose! During this time, the purge air entering the purge air connection pieces is unfiltered.

- ▶ Press snap locks (5) together and take off filter housing cover (4).
- ▶ Remove filter element (3) with twisting-pulling movements.
- ▶ Clean the inside of the filter housing and the filter housing cover with a cloth and brush.



**NOTICE:**

- ▶ For wet cleaning, use only a water-soaked cloth and then dry the parts well.

- ▶ Insert the new filter element with twisting-pressing movements.  
*Spare part:* Filter element Micro-Top element C11 100, Part No. 5306091
- ▶ Mount the filter housing cover, ensuring that it is aligned correctly with the housing, and snap the snap locks into place.
- ▶ Reconnect the purge air hose to the filter outlet using the hose clamp.
- ▶ Switch the fan on again.



### 5.4 Shutdown

The measuring system must be shut down:

- Immediately when the purge air supply fails
- If the equipment is to be put out of operation for a longer period of time (as from approx. 1 week)



**NOTICE:**

Never switch off or interrupt the purge air supply when the sender/receiver unit and reflector are fitted on the duct.

---

#### Work to be performed

- ▶ Loosen the connection line to the MCU.
- ▶ Dismantle the sender/receiver unit and reflector from the duct



**WARNING: Hazard through gas and hot parts**

- ▶ Observe the relevant safety regulations as well as the safety notices in Section 1 during all disassembly work.
  - ▶ Only remove the sender/receiver unit and reflector on equipment with hazard potential (higher internal duct pressure, hot or aggressive gases) when the equipment is at a standstill.
  - ▶ Take suitable protection measures against possible local hazards or hazards arising from the equipment.
  - ▶ Secure switches that should not be switched on again for safety reasons with signs and safeguards to prevent unintentional switching.
- 
- ▶ Close off the flange with tube with a blind plug.
  - ▶ Switch off the purge air supply
  - ▶ Loosen the hose clamps and pull the purge air hose off the connections and secure the hose ends against dirt and moisture
  - ▶ Disconnect the MCU control unit from the supply voltage.

#### Storage

- ▶ Store dismantled device parts in a clean, dry location.
- ▶ Use suitable auxiliary means to protect the connection line plug connectors against dirt and moisture.
- ▶ Secure purge air hoses against penetration by dirt and moisture.



## 6 Troubleshooting

### 6.1 General

Warning or error messages are output as follows:

- On the MCU, the respective relay is switched on (see “Standard connection”, page 53).
- “Maintenance requ.” or “Failure” is displayed in the status bar on the LC-Display of the MCU (option for DUSTHUNTER T50) (). In addition, the respective LED goes on (“MAINTENANCE REQUEST” for warnings, “FAILURE” for errors).  
After pressing the button “Diag”, possible causes are shown as short information in the menu “Diagnosis” after selecting the device (“MCU” or “DH T 50 / DH T100 / DH T200”).

Fig. 74: Display on the LC-Display

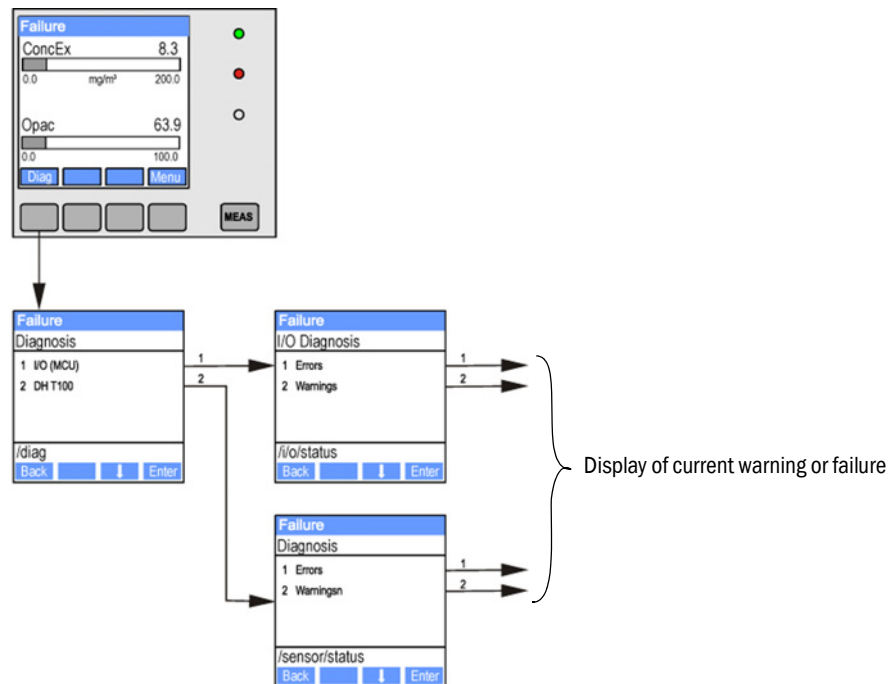

“Diagnosis / Error messages/warnings” provides detailed information on the current device state. To display, connect the measuring system to SOPAS ET and load the device file “DH T50 / DH T100 / DH T200” or “MCU” (see “Connection to the device via USB line”, page 58).

Move the mouse to the respective message to display more details on the significance of individual messages in a separate window. Clicking on the display shows a short description of possible causes and corrections under “Help” (see “Warning and error messages in SOPAS ET”, page 106, ).

Warning messages are output when internal limits for individual device functions/ components are reached or exceeded which can then lead to erroneous measured values or an imminent failure of the measuring system.



Warning messages do not imply a malfunction of the measuring system. The current measured value continues to be output on the analog output.



See the Service Manual for a detailed description of messages and options for clearance.

6.2 Sender/receiver unit

Malfunctions

Symptom	Possible cause	Action
<ul style="list-style-type: none"> <li>LEDs of the sender/receiver are not on</li> <li>No sender light beam</li> </ul>	<ul style="list-style-type: none"> <li>No supply voltage</li> <li>Connection line not connected correctly or defective</li> <li>Defective plug connector</li> </ul>	<ul style="list-style-type: none"> <li>▶ Check plug connectors and lines.</li> <li>▶ Contact SICK Customer Service.</li> </ul>

Warning and error messages in SOPAS ET

Fig. 75: SOPAS ET menu: DH T200/Diagnosis/Error messages/Warnings

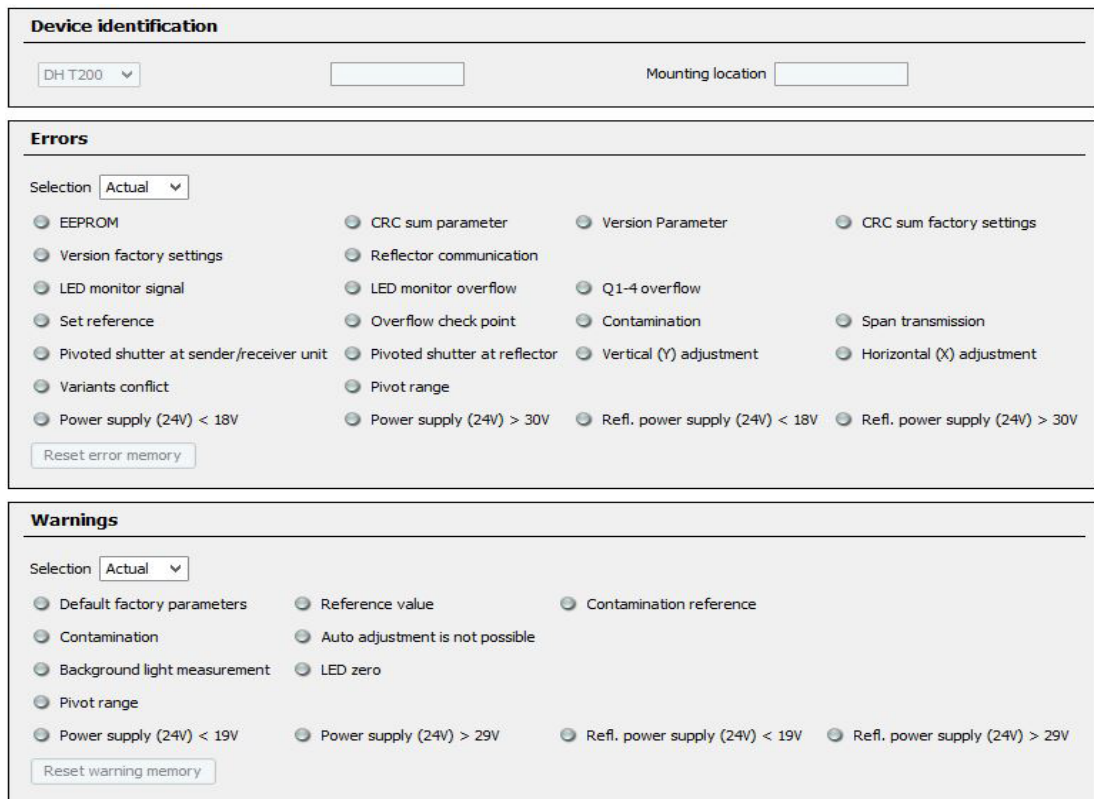

Current warning or error messages, or earlier messages stored in the error memory, can be shown by selecting “actual” or “memory” in the “Error selection” or “Warnings selection” window.

- Display of error or warning: With LED symbol
- Description of error or warning: In the description field of SOPAS ET

Malfunctions listed below can probably be cleared onsite.

Message	Significance	Possible cause	Action
Reflector communication (only for DUSTHUNTER T200)	No connection between sender/receiver unit and reflector	Connection line not connected or not connected correctly Defective connection line Defective reflector RS485 interface of the sender/receiver unit defective	Check the connection line Contact SICK Customer Service.
LED monitor overflow	Overmodulation of the monitor channel during scaling	Incorrect alignment of the optical axes of sender/receiver unit and reflector	Check/correct alignment. Repeat scaling
Q1-4 overflow	Group signal of quadrant measurement too high	Measuring system not scaled Changed alignment of optical axes Reduced active measuring path Wrong reflector	Scale measuring system. Check/correct alignment. Contact SICK Customer Service.
Set reference	Scaling not possible	Measurement or monitor signal too low (contamination, incorrect alignment)	Check/correct alignment. Clean the optical surfaces (see <a href="#">"Maintenance on the sender/receiver unit and reflector"</a> , page 95).
Contamination (not for DUSTHUNTER T50)	Contamination value is higher than the permitted limit value (see <a href="#">"Technical Data"</a> , page 112)	Deposits on the optical interfaces Unclean purge air	Clean the optical surfaces (see <a href="#">"Maintenance on the sender/receiver unit and reflector"</a> , page 95). Check purge air filter (see <a href="#">"Optional external purge air unit"</a> , page 103). Contact SICK Customer Service.
Power supply (24 V) < 18 V	Supply voltage too low	Line provided by customer does not match the specification (see <a href="#">"Connecting the MCU control unit"</a> , page 50) Voltage loss on the connection line (core cross-section too low in relation to the line length)	Check the connection line Contact SICK Customer Service.
Power supply (24 V) < 19 V			

6.3 MCU control unit

6.3.1 Malfunctions

Symptom	Possible cause	Action
No display on the LCD	<ul style="list-style-type: none"> <li>No supply voltage</li> <li>Connection line to LC-Display not connected or damaged</li> <li>Defective fuse</li> </ul>	<ul style="list-style-type: none"> <li>▶ Check voltage supply.</li> <li>▶ Check the connection line</li> <li>▶ Exchange fuse.</li> <li>▶ Contact SICK Customer Service.</li> </ul>

6.3.2 Warning and error messages in the SOPAS ET program

Fig. 76: SOPAS ET menu: MCU/Diagnosis/Error messages/Warnings

**Device Identification**

MCU Selected variant: DUSTHUNTER S (SB50, SB100,SF100,SP100) Mounting Location: SICK

---

**System Status MCU**

Operation 
  Malfunction 
  Maintenance Request 
  Maintenance 
  Function Check

---

**Configuration Errors**

AO configuration     AI configuration     DO configuration     DI configuration  
 Sensor configuration     Interface Module     MMC/SD card     Application selection  
 "Limit and status" not possible     Pressure transmitter type not supported     Error current and LZ overlaps     Option emergency air not possible

---

**Errors**

EEPROM     I/O range error     I²C module  
 Firmware CRC     AI NAMUR     Power supply 5V  
 Power supply 12V     Power supply(24V) <21V     Power supply(24V) >30V  
 Transducer temperature too high - emergency air activated     Key module not available     Key module too old

---

**Warnings**

Factory settings     No sensor found     Testmode enabled  
 Interfacemodule Inactive     RTC     I²C module  
 Power supply(24V) <22V     Power supply(24V) >29V     Flash memory

- Display of error or warning: With LED symbol
- Description of error or warning: In the description field of SOPAS ET

Malfunctions listed below can probably be cleared onsite.

Message	Significance	Possible cause	Action
AO configuration	the number of available and configured analog outputs is not identical.	<ul style="list-style-type: none"> <li>No parameters set for AO</li> <li>Connection error</li> <li>Module failure</li> </ul>	<ul style="list-style-type: none"> <li>▶ Check configuration (see <a href="#">“Setting the analog outputs parameters”, page 76</a>).</li> <li>▶ Contact SICK Customer Service.</li> </ul>
AI configuration	Number of available and configured analog inputs not identical.	<ul style="list-style-type: none"> <li>No parameters set for AI</li> <li>Connection error</li> <li>Module failure</li> </ul>	<ul style="list-style-type: none"> <li>▶ Check configuration (see <a href="#">“Setting the analog inputs parameters”, page 78</a>).</li> <li>▶ Contact SICK Customer Service.</li> </ul>
Interface Module	No communication via Interface module	<ul style="list-style-type: none"> <li>No parameters set for module</li> <li>Connection error</li> <li>Module failure</li> </ul>	<ul style="list-style-type: none"> <li>▶ Check configuration (see <a href="#">“Setting the Ethernet module parameters”, page 85</a>).</li> <li>▶ Contact SICK Customer Service.</li> </ul>
No sensor found	Sender/receiver unit was not recognized	<ul style="list-style-type: none"> <li>Communication problems on RS485 line</li> <li>Supply voltage problems</li> </ul>	<ul style="list-style-type: none"> <li>▶ Check system settings.</li> <li>▶ Check the connection line</li> <li>▶ Check voltage supply.</li> <li>▶ Contact SICK Customer Service.</li> </ul>
Variant configuration error	MCU setting does not match the connected sensor	Sensor type has been changed	<ul style="list-style-type: none"> <li>▶ Correct application settings (see <a href="#">“Assigning the MCU to the sender/receiver unit”, page 73</a>).</li> </ul>
Testmode enabled	MCU in “Test” mode.		<ul style="list-style-type: none"> <li>▶ Deactivate “System Test” mode (“Maintenance” directory)</li> </ul>

### 6.3.3 Replacing the fuse

- ▶ Control unit MCU must be disconnected from the power supply and potential-free.
- ▶ Open the door of the MCU, remove and open fuse holder (1).
- ▶ Replace the defective fuse (2) (see “Miscellaneous”, page 125).
- ▶ Close and attach the fuse holder.
- ▶ Close the door and connect power voltage.

Fig. 77: Replacing the fuse

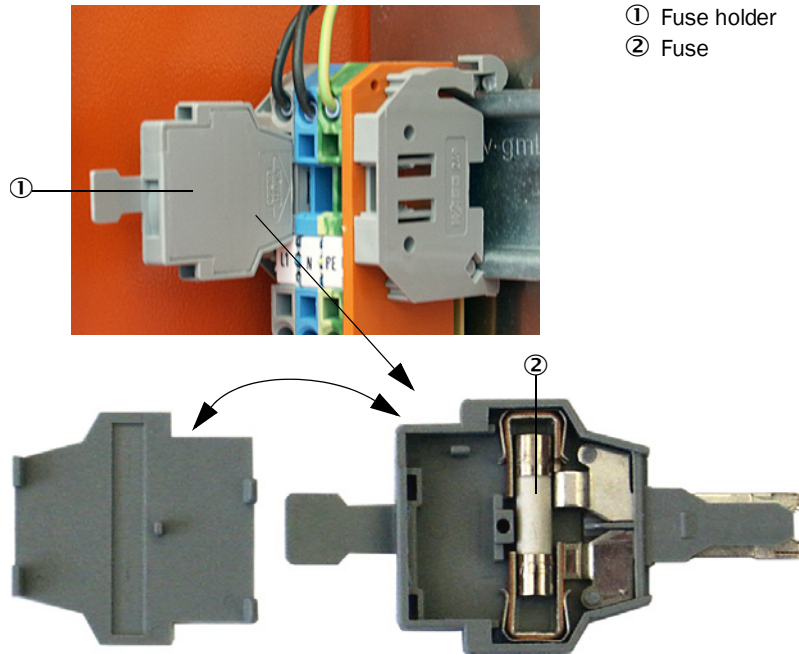

## 7 Specifications

### 7.1 Compliances

The technical design of this device complies with the following EU directives and EN standards:

- EU Directive: LVD (Low Voltage Directive)
- EU Directive: EMC (Electromagnetic Compatibility)

Applied EN standards:

- EN 61010-1, Safety requirements for electrical equipment for measurement, control and laboratory use
- EN 61326, Electrical equipment for measurement technology, control technology and laboratory use - EMC requirements
- EN 14181, Stationary source emissions - Quality assurance of automated measuring systems

#### Electrical protection

- Insulation: Protection class 1 according to EN 61010-1.
- Insulation coordination: Measuring category II according to EN 61010-1.
- Contamination: The device operates safely in an environment up to degree of contamination 2 according to EN 61010-1 (usual, not conductive contamination and temporary conductivity by occasional moisture condensation).
- Electrical energy: The wiring system to the power supply voltage of the system must be installed and fused according to the relevant regulations.

#### Approvals

The DUSTHUNTER T100 and DUSTHUNTER T200 variants are performance-tested in accordance with EN 15267 and may be used for continuous emission monitoring in plants requiring approval and plants according to the EU Directives.

7.2 Technical Data

Procedure	DUSTHUNTER T50		DUSTHUNTER T100		DUSTHUNTER T200	
Measuring Parameters						
Measured variable	Transmission, opacity, relative opacity, extinction, dust concentration					
Measuring range (freely adjustable)	Min.	Max.	Min.	Max.	Min.	Max.
• Transmission	100 ... 50%	100 ... 0%	100 ... 80%	100 ... 0%	100 ... 90%	100 ... 0%
• Opacity	0 ... 50%	0 ... 100%	0 ... 20%	0 ... 100%	0 ... 10%	0 ... 100%
• Relative opacity	0 ... 50%	0 ... 100%	0 ... 20%	0 ... 100%	0 ... 10%	0 ... 100%
• Extinction	0 ... 0,3	0 ... 1	0 ... 0,1	0 ... 2	0 ... 0,045	0 ... 2
• Dust concentration	min. 0 ... 200 mg/m <sup>3</sup>		max. 0 ... 10,000 mg/m <sup>3</sup>			
Measurement uncertainty	± 2%					
Response time	1 ... 600 s; freely selectable					
Zero point error <sup>[1]</sup>	± 1.0% transmission		± 0.4% transmission		± 0.2% transmission	
Measuring Conditions						
Active measuring path <sup>[2]</sup>	0.5...2.5/2...5/4...8 m		0.5...2.5/2...5/4...12 m			
Swivel error <sup>[3]</sup>	1.0% transmission		0.8% transmission		0.2% transmission	
Gas temperature (above dew point)	-40 ... 600 °C		Higher on request			
Sample gas pressure	-50 hPa ... +2 hPa -50 hPa... +30 hPa		MCU-P control unit Optional external purge air unit			
Ambient temperature	-40 ... +60 °C -40 ... +45 °C		Sender/receiver unit, reflector, MCU-N control unit MCU-P control unit, intake temperature for purge air			
Function Check						
Automatic self-test	Linearity, drift, aging, contamination Contamination limit values <sup>1)</sup> : As from 20% warning; as from 30% failure (DUSTHUNTER T100) As from 30% warning; as from 40% failure (DUSTHUNTER T200)					
Manual linearity check	Using a reference filter					
Output Signals						
Analog output	0/2/4 ... 20 mA, max. load 500 W (standard output max. 750 W; resolution 10 bits; electrically isolated 1 output on DUSTHUNTER T50, 3 outputs on DUSTHUNTER T100/T200; Further analog outputs by using I/O modules (option, see "MCU control unit", page 22)					
Relay output	5 potential-free outputs (changeover contacts) for status signal; load 48 V, 1 A					

[1] In temperature range - -20 °C ... +50 °C  
 [2] Upper limit only with distortion-free fitting  
 [3] With swivel angle ± 0.3°; total swivel range ±1°

Input signals	
Analog input	2 inputs 0...20 mA (standard; without electric isolation); resolution 10 bits 2 further analog inputs when using an I/O module (option, see "MCU control unit", page 22)
Digital input	4 inputs to connect potential-free contacts (e.g., for external maintenance switch, triggering function check);
Communication Interfaces	
USB 1.1, RS 232 (on terminals)	For measured value inquiries and software updates per PC/laptop using the operating program
RS485	For connection of sender/receiver unit
Optional Interface module	To communicate with the host PC, optional for Profibus DP, Ethernet (Cola B), Modbus TCP



Power supply		
MCU control unit	Voltage supply: Output:	90...250 V AC, 47...63 Hz; opt. 24 V DC $\pm$ 2 V Max. 30 W without purge air supply Max. 70 W with purge air supply
Sender/receiver unit	Voltage supply: Output:	24 V from MCU control unit Max. 15 W
Optional external purge air unit (with blower 2BH13)	Voltage supply: Rated current: Motor rating:	200 ... 240 V/345...415 V at 50 Hz; 220...275 V/380...480 V at 60 Hz 2.6 A/Y 1.5 A 0.37 kW at 50 Hz; 0.45 kW at 60 Hz
MCU connection line	Shielded lines with twisted pairs (e.g., UNITRONIC LiYCY (TP) 2 x 2 x 0.5 mm <sup>2</sup> from LAPPKabel; 1 pair of wires for RS 485, 1 pair of wires for power supply; not suitable for underground laying).	
Weight		
Sender/receiver unit	5 kg 6.5 kg 10 kg	DHT-T00 DHT-T10 DHT-T21
Reflector	1 kg 3 kg 5 kg	DHT-R50, DHT-R51 DHT-R00, DHT-R01, DHT-R02 DHT-R10, DHT-R11, DHT-R12
MCU control unit	13.5 kg 3.7 kg	MCU-P MCU-N
Optional external purge air unit	14 kg	
Miscellaneous		
Protection class	IP 66 IP 54	Sender/receiver unit, reflector, MCU-N control unit Optional external purge air unit
Connection line length	5 m, 10 m, 20 m <sup>4)</sup> , 50 m <sup>4)</sup>	Other lengths on request
Purge air hose length	5 m, 10 m	Other lengths on request
Sender LED	White light, wavelength between 450 nm and 700 nm	
Purge air feed volume	Max. 20 m <sup>3</sup> /h Max. 63 m <sup>3</sup> /h	MCU-P control unit Optional external purge air unit

4): For connecting reflector DHT-R1x (DUSTHUNTER T200) to the sender/receiver unit

### 7.2.1 Dust concentration measuring range

The limits for the smallest/largest measuring range depend on the extinction measuring range, active measuring path and optical particle characteristics. Therefore exact range limits cannot be specified here. The following charts can be used to estimate the ranges used. These have been determined based on SICK's many years of experience and are valid assuming constant particle size and characteristics.

Fig. 78: Measuring ranges for dust concentration measurement based on extinction

Smallest measuring range

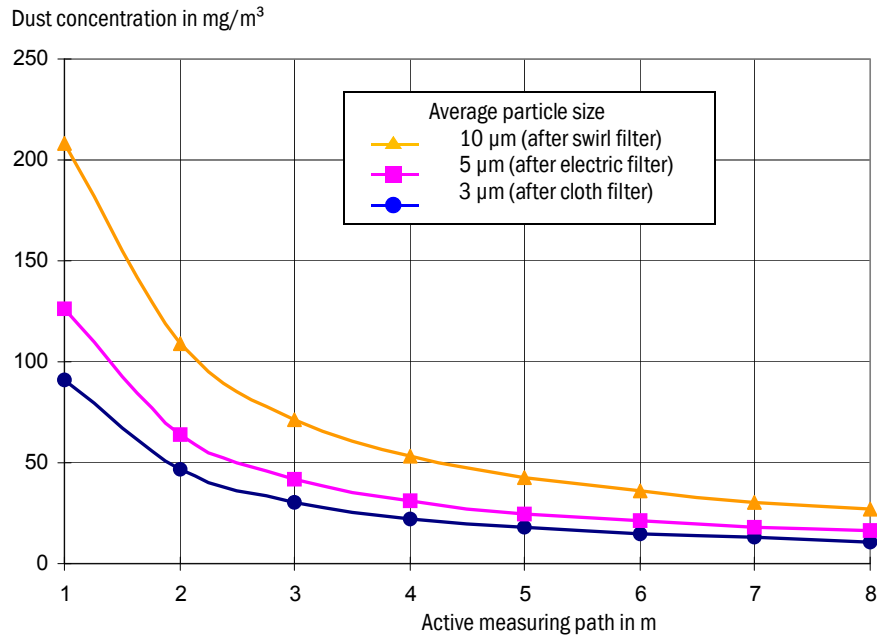

Largest measuring range

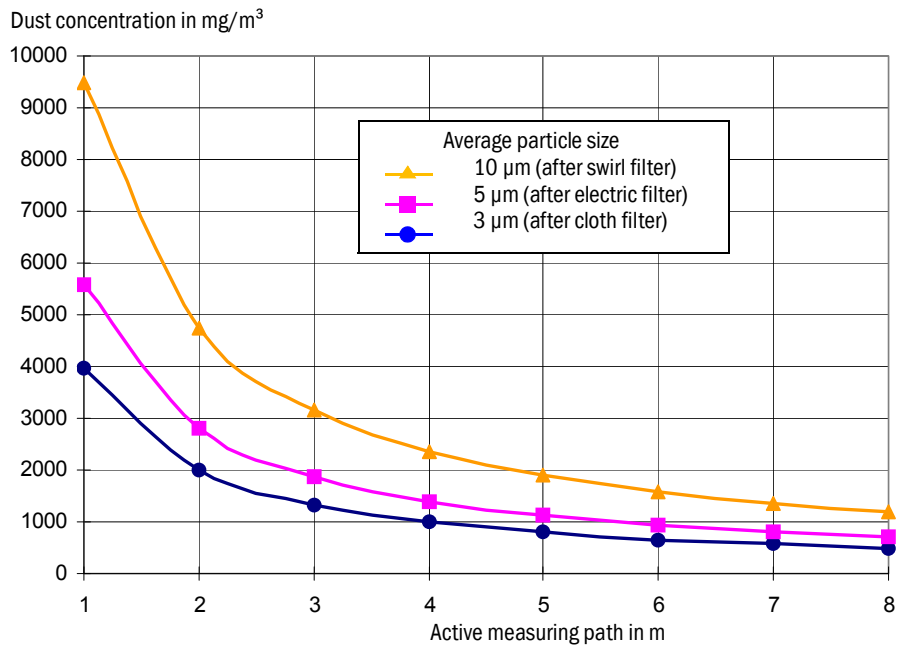

7.3 Dimensions, part Nos.

All measures are specified in mm.

7.3.1 Sender/receiver unit

Fig. 79: Sender/receiver unit DHT-T00

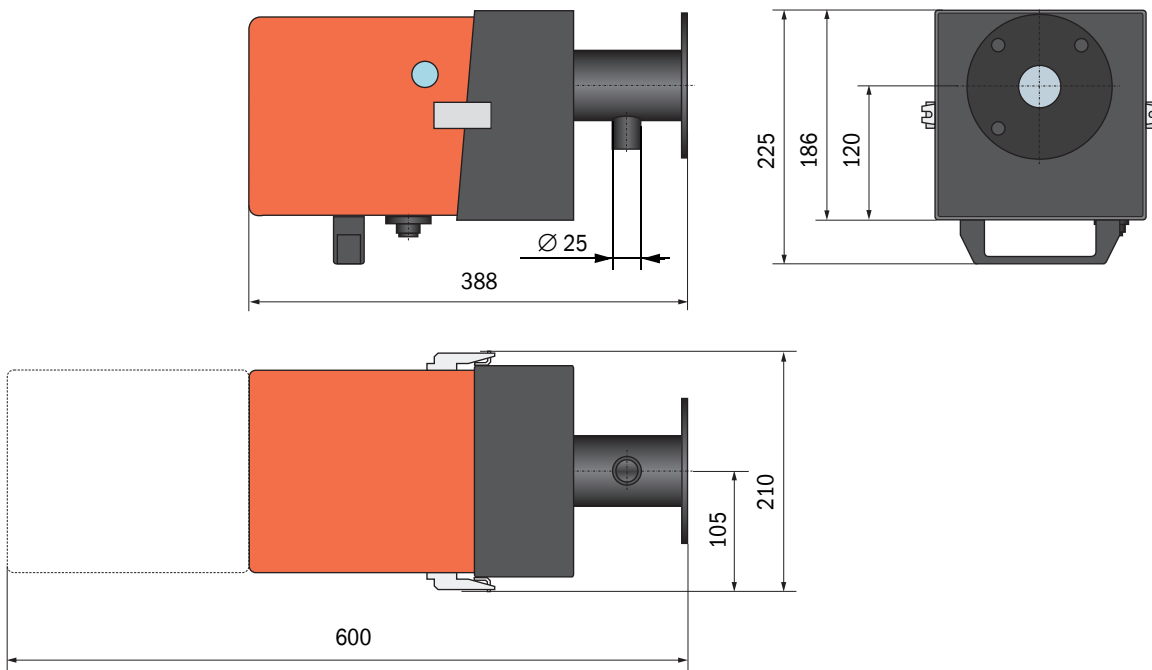

Designation	Part No.
Sender/receiver unit DHT-T00	1043902

Fig. 80: Sender/receiver unit DHT-T10, DHT-T21

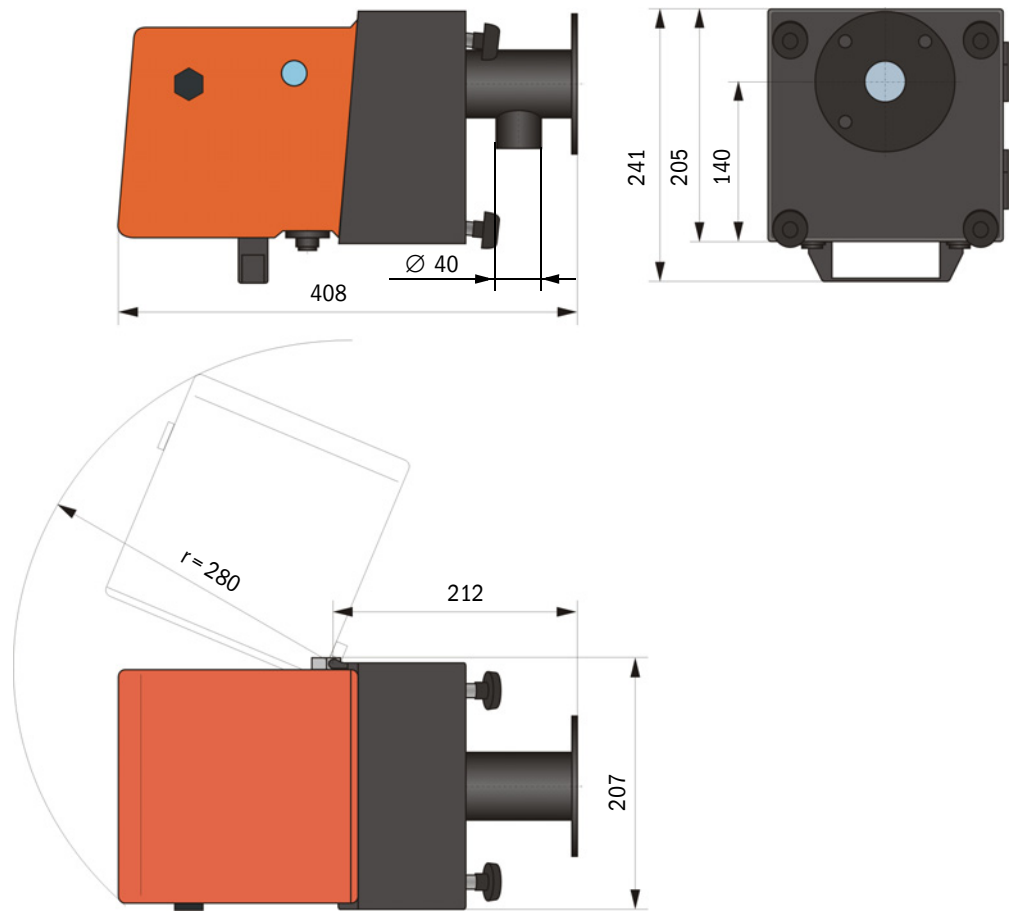

Designation	Part No.
Sender/receiver unit DHT-T10	1043903
Sender/receiver unit DHT-T21	1043904

7.3.2 Reflector

Fig. 81: Reflector DHT-R5x

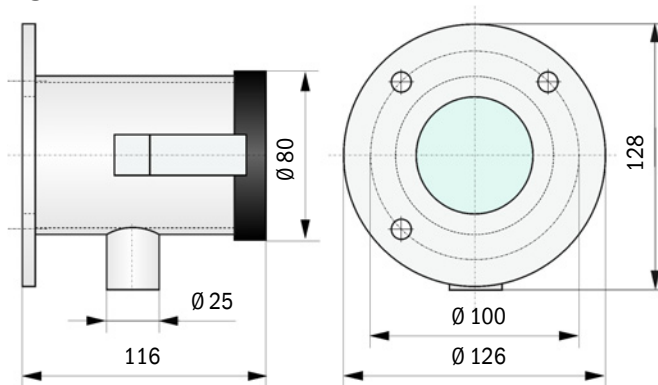

Designation	Part No.
Reflector DHT-R50	1029495
Reflector DHT-R51	1029715
Reflector DHT-R52	1040169

7.3.3 Reflector DHT-R0x, DHT-R1x

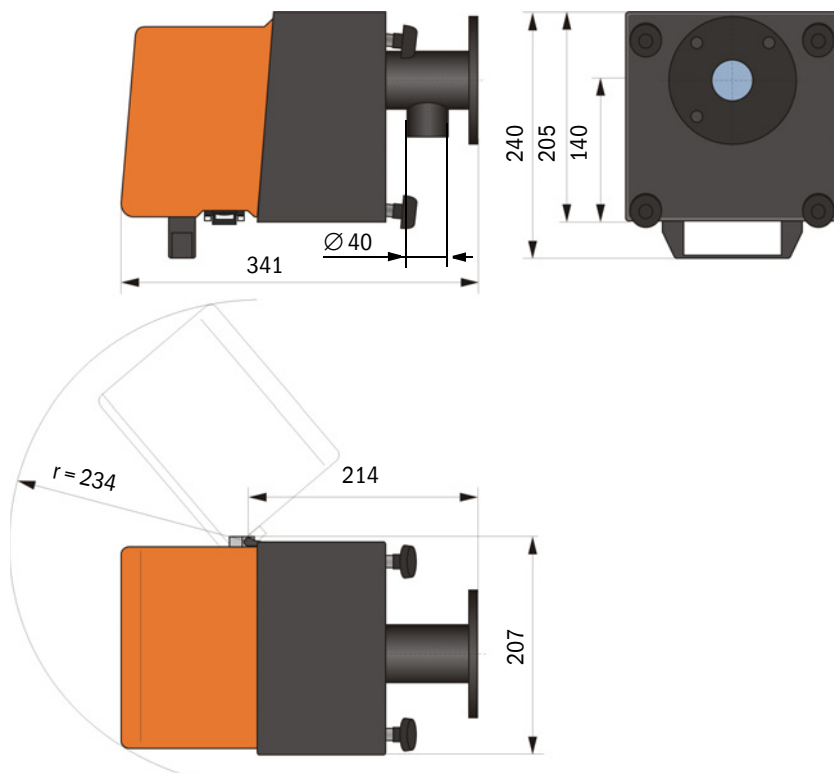

Designation	Part No.
Reflector DHT-R00	1043905
Reflector DHT-R10	1043906
Reflector DHT-R01	1043907
Reflector DHT-R11	1043908
Reflector DHT-R02	1044093
Reflector DHT-R12	1044244
Reflector DHT-R13 (for active measuring paths up to 50 m)	1046009

7.3.4 Flange with tube

7.3.4.1 Flange with tube (standard)

Fig. 82: Flange with tube

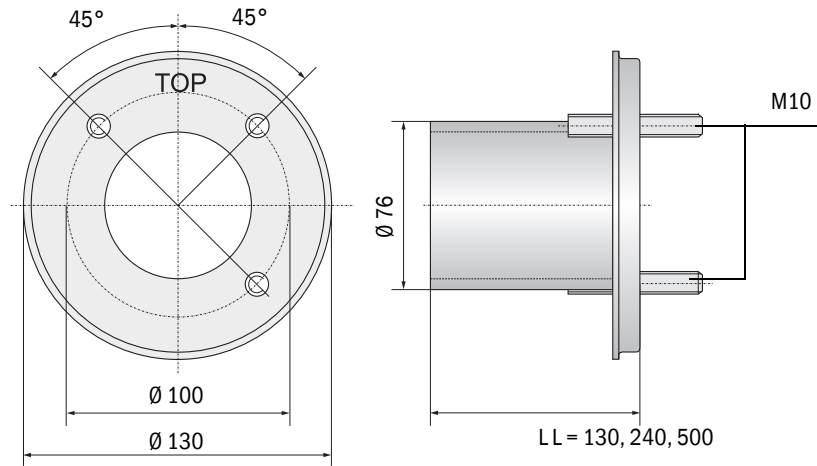

Designation	Part No.
Flange with tube, Di = 70.2 Length 130 mm, St37	2017845
Flange with tube, Di = 70.2 Length 240 mm, St37	2017847
Flange with tube, Di = 70.2 Length 500 mm, St37	2017849
Flange with tube, Di = 70.2 Length 130 mm, 1.4571	2017846
Flange with tube, Di = 70.2 Length 240 mm, 1.4571	2017848
Flange with tube, Di = 70.2 Length 500 mm, 1.4571	2017850

7.3.4.2 Flange with tube (fail-safe shutter)

Fig. 83: Flange with tube for fitting the fail-safe shutter

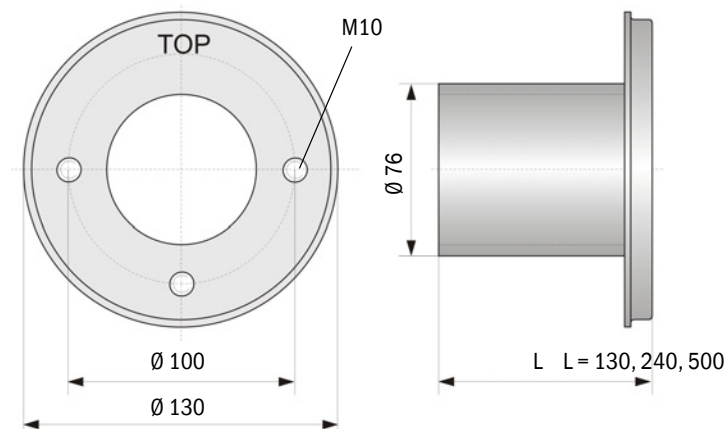

Designation	Part No.
Flange with tube, Di = 70.2 Length 130 mm, St37	2017839
Flange with tube, Di = 70.2 Length 240 mm, St37	2017840
Flange with tube, Di = 70.2 Length 500 mm, St37	2017842
Flange with tube, Di = 70.2 Length 240 mm, 1.4571	2017841

7.3.5 MCU control unit

MCU-N control unit and MCU remote control unit without integrated purge air supply

Fig. 84: MCU-N control unit

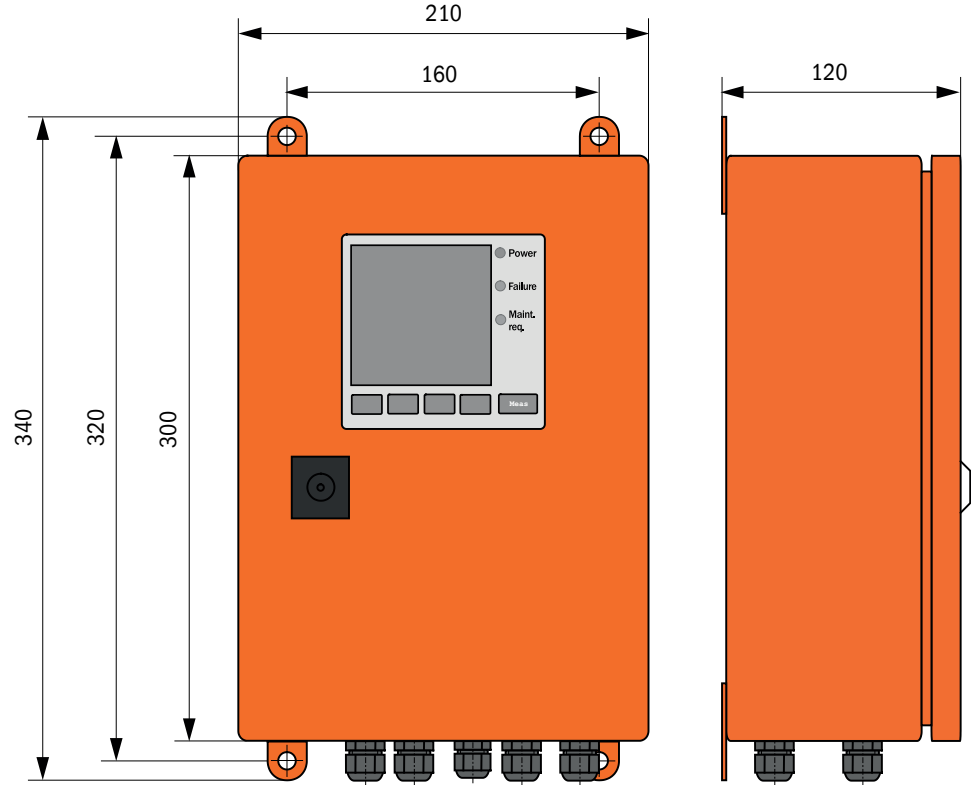

Designation	Part No.
Control unit MCU-NWONN00000NNNE in wall-mounted enclosure (orange), Supply voltage 90 ... 250 V AC, without purge air unit, without display <sup>[1]</sup>	1040667
Control unit MCU-NWODN00000NNNE in wall-mounted enclosure (orange), Supply voltage 90 ... 250 V AC, without purge air unit, with display <sup>1)</sup>	1040675
Control unit MCU-N2ONN00000NNNE in wall-mounted enclosure (orange), Supply voltage 24 V DC, without purge air unit, without display <sup>1)</sup>	1040669
Control unit MCU-N2ODN00000NNNE in wall-mounted enclosure (orange), Supply voltage 24 V DC, without purge air unit, with display <sup>1)</sup>	1040677
Control unit MCU-NWONN01000NNNE in wall-mounted enclosure (orange), Supply voltage 90 ... 250 V AC, without purge air unit, with display <sup>1)</sup>	1044496
Control unit MCU-NWODN01000NNNE in wall-mounted enclosure (orange), Supply voltage 90 ... 250 V AC, without purge air unit, with display	1045001
Control unit MCU-N2ONN01000NNNE in wall-mounted enclosure (orange), Supply voltage 24 V DC, without purge air unit, without display <sup>1)</sup>	1044999
Control unit MCU-N2ODN01000NNNE in wall-mounted enclosure (orange), Supply voltage 24 V DC, without purge air unit, with display	1045003
MCU remote control unit without power supply unit	2075567
MCU remote control unit with power supply unit	2075568

[1] Only for DUSTHUNTER T50

**MCU-P control unit with integrated purge air supply**

Fig. 85: MCU-P control unit

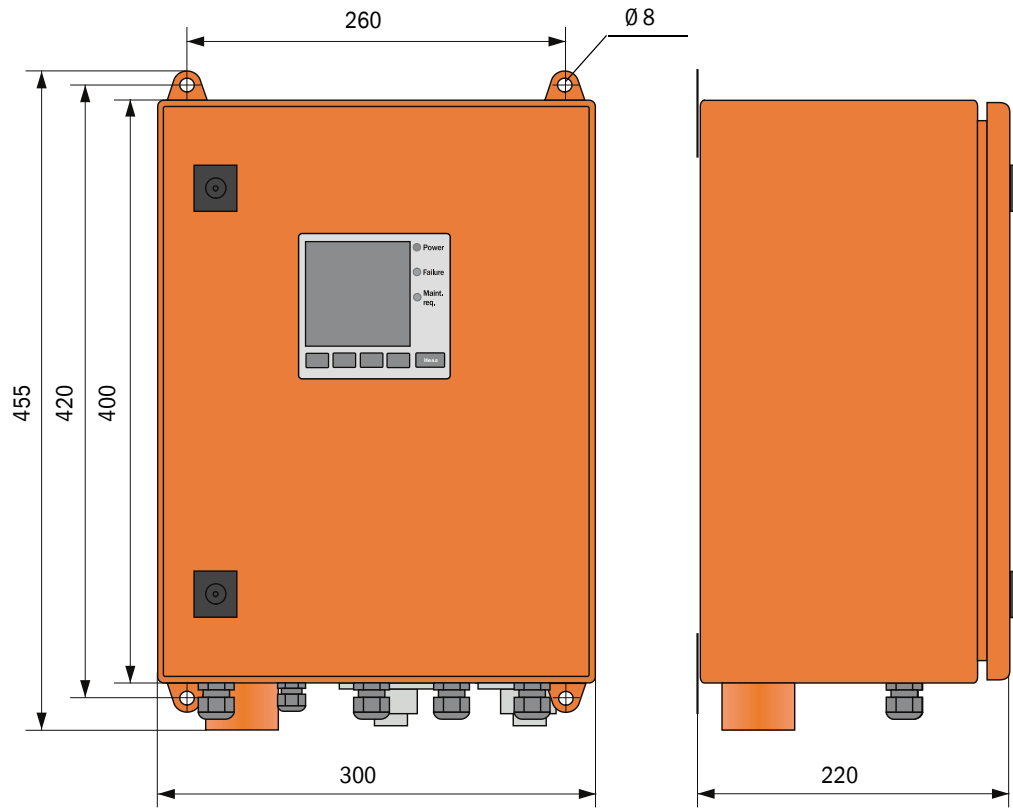

Designation	Part No.
Control unit MCU-PWONN00000NNNE in wall-mounted enclosure (orange), Supply voltage 90 ... 250 V AC, with purge air unit, without display <sup>[1]</sup>	1040668
Control unit MCU-PWODN00000NNNE in wall-mounted enclosure (orange), Supply voltage 90 ... 250 V AC, with purge air unit, with display <sup>1)</sup>	1040676
Control unit MCU-P2ONN00000NNNE in wall-mounted enclosure (orange), Supply voltage 24 V DC, with purge air unit, without display <sup>1)</sup>	1040670
Control unit MCU-P2ODN00000NNNE in wall-mounted enclosure (orange), Supply voltage 24 V DC, with purge air unit, with display <sup>1)</sup>	1040678
Control unit MCU-PWONN01000NNNE in wall-mounted enclosure (orange), Supply voltage 90 ... 250 V AC, with purge air unit, without display <sup>1)</sup>	1044497
Control unit MCU-PWODN01000NN in wall-mounted enclosure (orange), Supply voltage 90 ... 250 V AC, with purge air unit, with display	1045002
Control unit MCU-P2ONN01000NNNE in wall-mounted enclosure (orange), Supply voltage 24 V DC, with purge air unit, without display <sup>1)</sup>	1045000
Control unit MCU-P2ODN01000NNNE in wall-mounted enclosure (orange), Supply voltage 24 V DC, with purge air unit, with display	1045004

[1] Only for DUSTHUNTER T50



7.3.6 Optional external purge air unit

Fig. 86: Optional external purge air unit

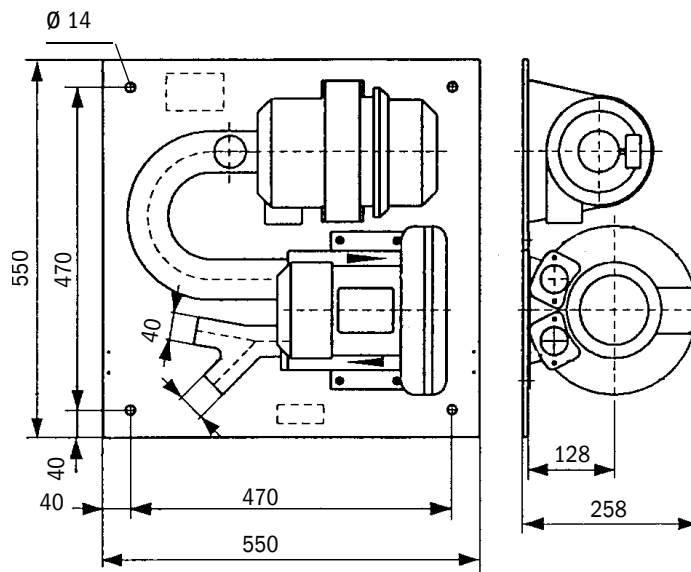

Designation	Part No.
Purge air unit with blower 2BH13 and purge air hose, length 5 m	1012424
Purge air unit with blower 2BH13 and purge air hose, length 10 m	1012409

7.3.7 Weatherproof covers

Weatherproof cover for external purge air unit

Fig. 87: Weatherproof cover for external purge air unit

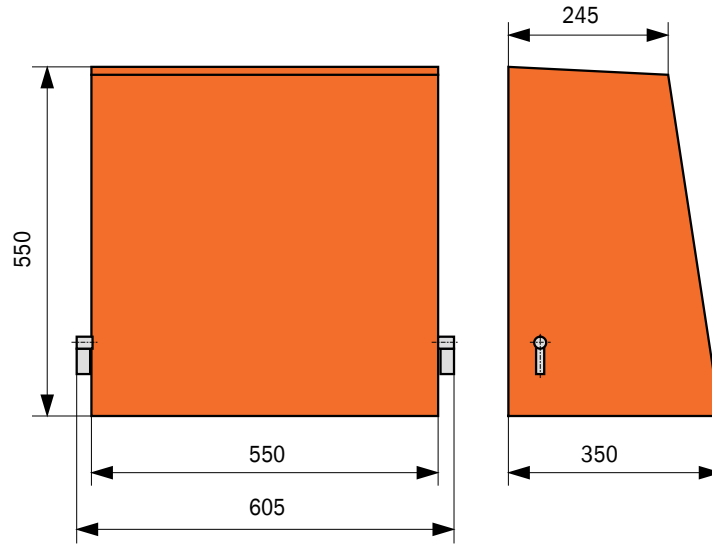

Designation	Part No.
Weatherproof cover for purge air unit	5306108

Weatherproof cover for sender/receiver unit and reflector

Fig. 88: Weatherproof cover for analyzer

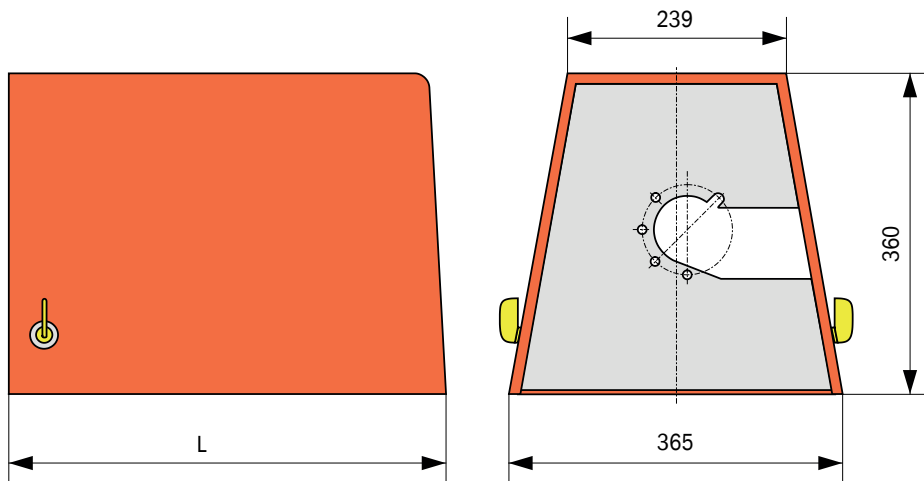

Designation	Part No.	L in mm
Weatherproof cover for analyzer	2702407	492
Weatherproof cover for analyzer, extended for FSS	2065677	550

7.3.8 Components for hall air monitoring (option)

Fig. 89: Holder for light/dust protection tube

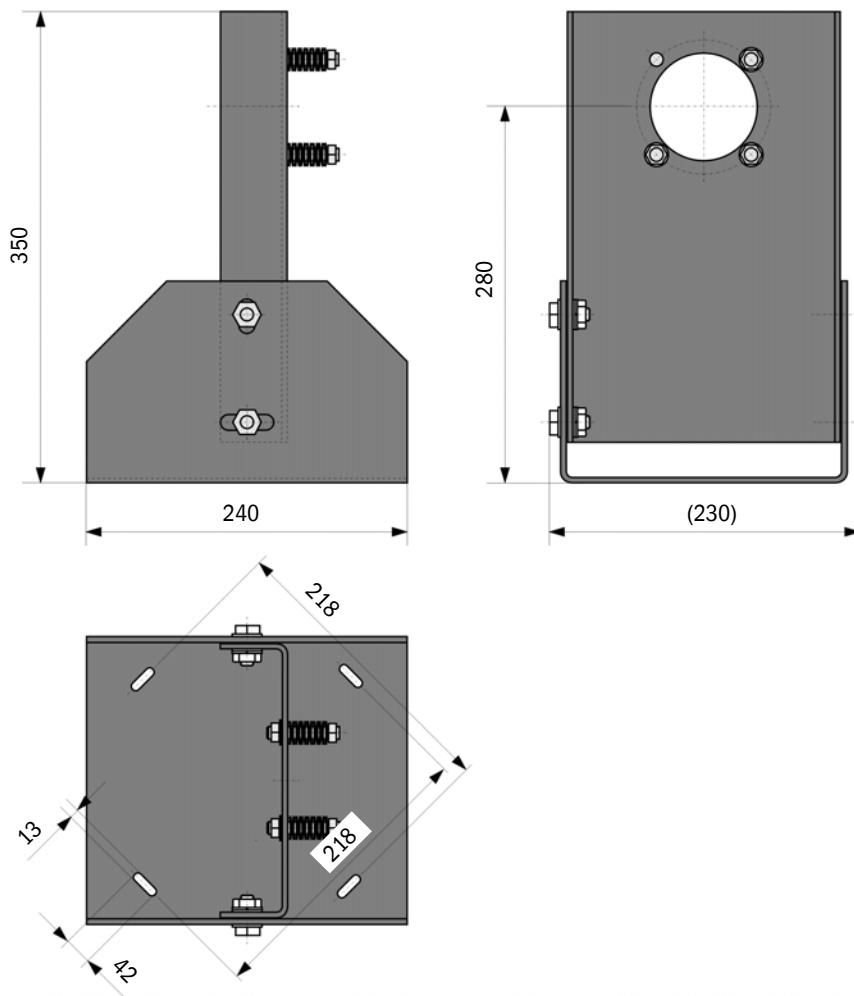

Designation	Part No.
Holder for light/dust protection tube	2071484

Fig. 90: Dust protection tube

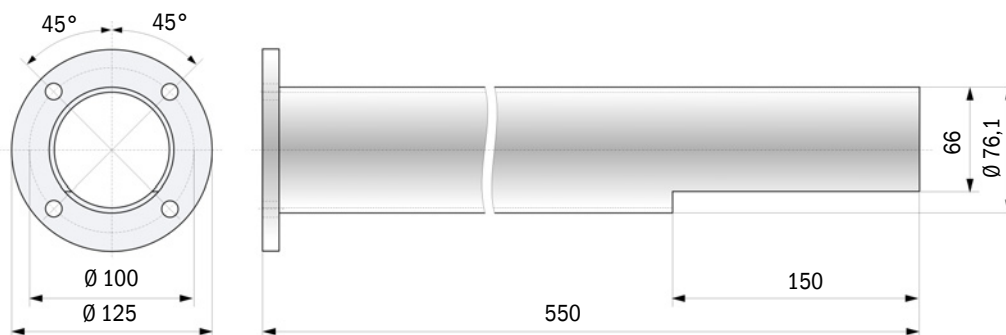

Designation	Part No.
Dust protection tube	2071437

**7.4 Accessories**

**7.4.1 Line sender/receiver unit - MCU**

Designation	Part No.
Connection line, length 5 m	7042017
Connection line, length 10 m	7042018

**7.4.2 Line sender/receiver unit - reflector**

Only for DUSTHUNTER T200

Designation	Part No.
Connection line, length 5 m	2045416
Connection line, length 10 m	2045417
Connection line, length 20 m	2048674
Connection line, length 50 m	2048675

**7.4.3 Purge air supply**

Designation	Part No.
Purge air hose DN 25, length 5 m	2046091
Purge air hose DN 25, length 10 m	7047536
Hose clamp D20-32	7045039
Hose clamp D32-52	5300809
Automatic fail-safe shutter 24V - 240V, 50/60Hz	6049194
Differential pressure sensor	2017809

**7.4.4 Assembly parts**

Designation	Part No.
Assembly kit, flange - analyzer	2018183
Assembly kit, flange - reflector	2018184

**7.4.5 Device check accessories**

Designation	Part No.
Check filter set	2048676
Check filter set EPA	2050050
Adjusting stand	2042907

#### 7.4.6 Options for MCU control unit

Designation	Part No.
Analog input module, 2 channels, 100 W, 0/4...22 mA, electrically isolated	2034656
Analog output module, 2 channels, 500 W 0/4 ... 22 mA, Electrically isolated per module	2034657
Module carrier (for one each AI or AO module)	6033578
Connection line for optional I/O modules	2040977
Interface, Profibus module DP V0	2048920
Interface module Ethernet type 1	2055719
Interface module Ethernet type 2	2069666
Modbus TCP module	2059546

#### 7.4.7 Miscellaneous

Designation	Part No.
Optical adjusting device for flange assembly	1700462
Cover	2052377
Fuse set T 2 A (for MCU with power voltage supply)	2054541
Fuse set T 4 A (for MCU with 24 V supply)	2056334

### 7.5 Consumable parts for 2-years operation

#### 7.5.1 Sender/receiver unit and reflector

Designation	Number	Part No.
Sealing tape	4	4704676
Optics cloth	4	4003353

#### 7.5.2 MCU with integrated purge air supply

Designation	Number	Part No.
Filter element C1140	4	7047560

#### 7.5.3 Optional external purge air unit

Designation	Number	Part No.
Filter element Micro-Topoelement C11 100	4	5306091

## 8 Index

<b>A</b>		<b>P</b>	
Additional documentation (information) .....	9	Parameter protocol .....	82
Adjusting (aligning) .....	61	Parameter setting .....	57, 73
Adjusting stands for scaling .....	31	Password For LC-Display .....	86
Aligning (adjusting) .....	61	Password for SOPAS ET .....	58
<b>C</b>		Potentially explosive atmospheres .....	8
Calibration .....	80	Processor board .....	51
Check cycle .....	13	Product description .....	11
Circuit board connections .....	51	Purge air unit .....	28
COM port .....	58	<b>R</b>	
Connect with SOPAS ET .....	58	Reflector .....	20
Connecting Ethernet .....	60	Remote control unit .....	54
Contamination measurement .....	14	Reset maintenance .....	93
Control unit .....	16	Response time .....	12
Creating a USB connection .....	58	Responsibility of user .....	9
<b>D</b>		Restrictions of use .....	8
Data backup .....	82	Resuming measuring operation .....	93
Determining the function check .....	75	<b>S</b>	
Differential pressure sensor .....	29	Scaling .....	67
Display .....	26	Self-alignment .....	19
Display settings .....	91	Set reference .....	31
<b>E</b>		Setting the analog inputs parameters .....	78
Error clearance .....	106	Setting the analog outputs parameters .....	76
<b>F</b>		Setting the Ethernet module parameters .....	85
Fail-safe shutters .....	29, 44	Setting the Interface module parameters .....	84
Fitting the I/O module .....	56	SOPAS ET .....	34
Fitting the interface modules .....	56	SOPAS ET data backup .....	82
Flange with tube .....	21	Symbols in this document .....	8
Focussing the sender light beam .....	64	<b>T</b>	
Function check .....	13	Troubleshooting .....	106
Functional principle .....	11	Type code .....	25
<b>H</b>		<b>U</b>	
Hall air monitoring .....	29, 45	User	
<b>I</b>		- Responsibility of user .....	9
I/O module .....	27	<b>W</b>	
Important Information .....	7	Warning messages .....	106
Installation site .....	8	<b>Z</b>	
Intended use .....	8	Zero tube for scaling .....	31
Interface module .....	27		
Interfaces .....	22		
<b>L</b>			
Linearity test .....	31		
<b>M</b>			
Malfunctions .....	106		
MCU .....	16, 22		
MCU remote control unit .....	27		
Measured values .....	8		
Measuring function (general) .....	8		
Menu structure .....	87		



**Australia**

Phone +61 3 9457 0600  
1800 334 802 – tollfree  
E-Mail sales@sick.com.au

**Austria**

Phone +43 (0)22 36 62 28 8-0  
E-Mail office@sick.at

**Belgium/Luxembourg**

Phone +32 (0)2 466 55 66  
E-Mail info@sick.be

**Brazil**

Phone +55 11 3215-4900  
E-Mail marketing@sick.com.br

**Canada**

Phone +1 905 771 14 44  
E-Mail information@sick.com

**Czech Republic**

Phone +420 2 57 91 18 50  
E-Mail sick@sick.cz

**Chile**

Phone +56 2 2274 7430  
E-Mail info@schadler.com

**China**

Phone +86 4000 121 000  
E-Mail info.china@sick.net.cn

**Denmark**

Phone +45 45 82 64 00  
E-Mail sick@sick.dk

**Finland**

Phone +358-9-2515 800  
E-Mail sick@sick.fi

**France**

Phone +33 1 64 62 35 00  
E-Mail info@sick.fr

**Germany**

Phone +49 211 5301-301  
E-Mail info@sick.de

**Great Britain**

Phone +44 (0)1727 831121  
E-Mail info@sick.co.uk

**Hong Kong**

Phone +852 2153 6300  
E-Mail ghk@sick.com.hk

**Hungary**

Phone +36 1 371 2680  
E-Mail office@sick.hu

**India**

Phone +91-22-4033 8333  
E-Mail info@sick-india.com

**Israel**

Phone +972-4-6881000  
E-Mail info@sick-sensors.com

**Italy**

Phone +39 02 27 43 41  
E-Mail info@sick.it

**Japan**

Phone +81 (0)3 5309 2112  
E-Mail support@sick.jp

**Malaysia**

Phone +603 808070425  
E-Mail enquiry.my@sick.com

**Netherlands**

Phone +31 (0)30 229 25 44  
E-Mail info@sick.nl

**New Zealand**

Phone +64 9 415 0459  
0800 222 278 – tollfree  
E-Mail sales@sick.co.nz

**Norway**

Phone +47 67 81 50 00  
E-Mail sick@sick.no

**Poland**

Phone +48 22 837 40 50  
E-Mail info@sick.pl

**Romania**

Phone +40 356 171 120  
E-Mail office@sick.ro

**Russia**

Phone +7-495-775-05-30  
E-Mail info@sick.ru

**Singapore**

Phone +65 6744 3732  
E-Mail sales.gsg@sick.com

**Slovakia**

Phone +421 482 901201  
E-Mail mail@sick-sk.sk

**Slovenia**

Phone +386 (0)1-47 69 990  
E-Mail office@sick.si

**South Africa**

Phone +27 11 472 3733  
E-Mail info@sickautomation.co.za

**South Korea**

Phone +82 2 786 6321  
E-Mail info@sickkorea.net

**Spain**

Phone +34 93 480 31 00  
E-Mail info@sick.es

**Sweden**

Phone +46 10 110 10 00  
E-Mail info@sick.se

**Switzerland**

Phone +41 41 619 29 39  
E-Mail contact@sick.ch

**Taiwan**

Phone +886 2 2375-6288  
E-Mail sales@sick.com.tw

**Thailand**

Phone +66 2645 0009  
E-Mail tawiwat@sicksgp.com.sg

**Turkey**

Phone +90 (216) 528 50 00  
E-Mail info@sick.com.tr

**United Arab Emirates**

Phone +971 (0) 4 88 65 878  
E-Mail info@sick.ae

**USA/Mexico**

Phone +1(952) 941-6780  
1 (800) 325-7425 – tollfree  
E-Mail info@sick.com

**Vietnam**

Phone +84 8 62920204  
E-Mail Ngo.Duy.Linh@sicksgp.com.sg

More representatives and agencies  
at [www.sick.com](http://www.sick.com)