

Genie®



Service Manual

Refer to inside cover for additional serial number information

Part No. 128267

Rev A

July 2007

Z™-34/22 IC

(from serial number 3242 to 4799)

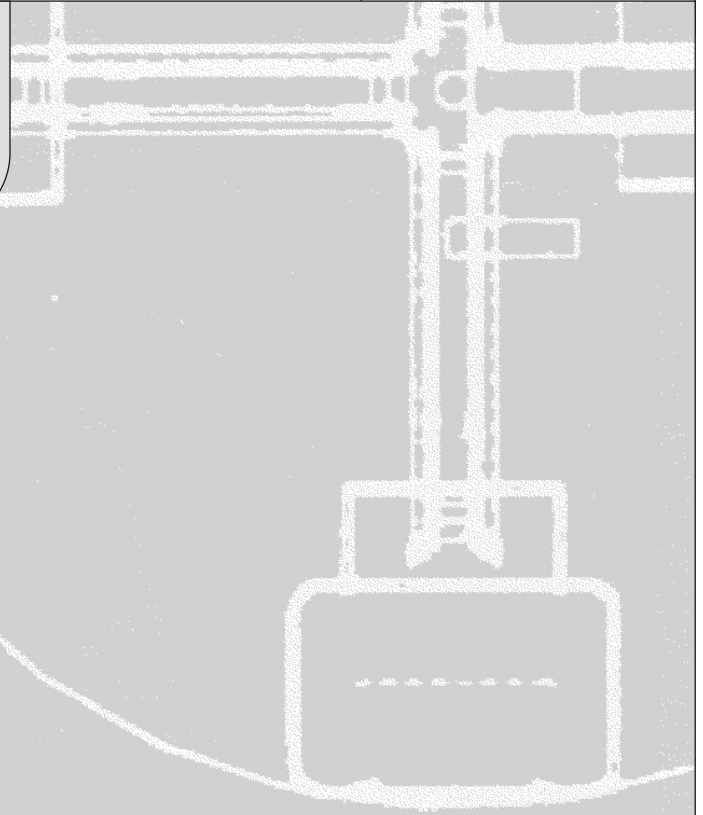

Introduction

Important

Read, understand and obey the safety rules and operating instructions in the appropriate *Genie Z-34/22 IC Operator's Manual* before attempting any maintenance or repair procedure.

This manual provides detailed scheduled maintenance information for the machine owner and user. It also provides repair procedures for qualified service professionals.

Basic mechanical, hydraulic and electrical skills are required to perform most procedures. However, several procedures require specialized skills, tools, lifting equipment and a suitable workshop. In these instances, we strongly recommend that maintenance and repair be performed at an authorized Genie dealer service center.

Technical Publications

Genie Industries has endeavored to deliver the highest degree of accuracy possible. However, continuous improvement of our products is a Genie policy. Therefore product specifications are subject to change without notice.

Readers are encouraged to notify Genie of errors and send in suggestions for improvement. All communications will be carefully considered for future printings of this and other manuals.

Contact Us:

<http://www.genieindustries.com>
e-mail: techsup@genieind.com

Serial Number Information

Genie Industries offers the following Service Manual for this models:

Title	Part No.
Z-34/22 IC Service Manual, First Edition (from serial number 101 to 1186)	43037
Z-34/22 IC Service Manual, Second Edition (from serial number 1187 to 3241)	119987
Z-34/22 IC Service Manual, Fourth Edition (from serial number 4800)	128300

Copyright © 1997 by Genie Industries

128267 Rev A July 2007
Third Edition, First Printing

"Genie" and "Z" are registered trademarks of Genie Industries in the USA and many other countries.

 Printed on recycled paper

Printed in U.S.A.

Serial Number Legend

Genie

Model: Z-34/22
Serial number: Z342207-12345
Model year: 2007 **Manufacture date:** 02/01/07
Electrical schematic number: ESXXXX
Machine unladen weight:

Rated work load (including occupants): XX kg
Maximum number of platform occupants: XX
Maximum allowable side force : XX N
Maximum allowable inclination of the chassis:
0 deg

Maximum wind speed : XX m/s
Maximum platform height : XX m
Maximum platform reach : XX m
Gradeability: N/A

Country of manufacture: USA

This machine complies with:

ANSI A92.5
CAN B.354.4

Genie Industries
18340 NE 76th Street
Redmond, WA 98052
USA



PN - 77055

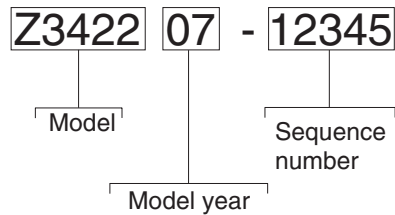

Serial number stamped on chassis

Serial label (located under cover)

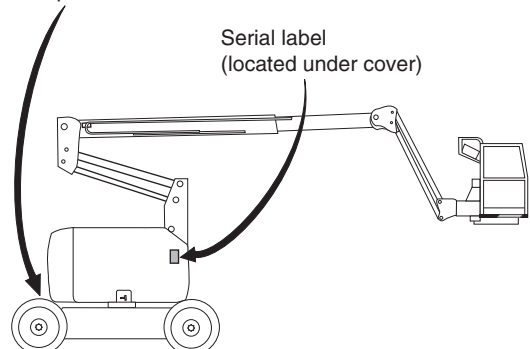

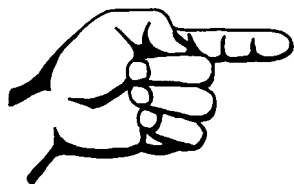

This page intentionally left blank.

Safety Rules



Danger

Failure to obey the instructions and safety rules in this manual and the appropriate *Genie Z-34/22 IC Operator's Manual* will result in death or serious injury.

Many of the hazards identified in the operator's manual are also safety hazards when maintenance and repair procedures are performed.

Do Not Perform Maintenance Unless:

- You are trained and qualified to perform maintenance on this machine.
- You read, understand and obey:
 - manufacturer's instructions and safety rules
 - employer's safety rules and worksite regulations
 - applicable governmental regulations
- You have the appropriate tools, lifting equipment and a suitable workshop.

SAFETY RULES

Personal Safety

Any person working on or around a machine must be aware of all known safety hazards. Personal safety and the continued safe operation of the machine should be your top priority.



Read each procedure thoroughly. This manual and the decals on the machine, use signal words to identify the following:



Safety alert symbol—used to alert personnel to potential personal injury hazards. Obey all safety messages that follow this symbol to avoid possible injury or death.



Indicates an imminently hazardous situation which, if not avoided, will result in death or serious injury.



Indicates a potentially hazardous situation which, if not avoided, could result in death or serious injury.



Indicates a potentially hazardous situation which, if not avoided, may cause minor or moderate injury.



Indicates a potentially hazardous situation which, if not avoided, may result in property damage.



Be sure to wear protective eye wear and other protective clothing if the situation warrants it.



Be aware of potential crushing hazards such as moving parts, free swinging or unsecured components when lifting or placing loads. Always wear approved steel-toed shoes.

Workplace Safety

Be sure to keep sparks, flames and lighted tobacco away from flammable and combustible materials like battery gases and engine fuels. Always have an approved fire extinguisher within easy reach.



Be sure that all tools and working areas are properly maintained and ready for use. Keep work surfaces clean and free of debris that could get into machine components and cause damage.



Be sure any forklift, overhead crane or other lifting or supporting device is fully capable of supporting and stabilizing the weight to be lifted. Use only chains or straps that are in good condition and of ample capacity.



Be sure that fasteners intended for one time use (i.e., cotter pins and self-locking nuts) are not reused. These components may fail if they are used a second time.



Be sure to properly dispose of old oil or other fluids. Use an approved container. Please be environmentally safe.



Be sure that your workshop or work area is properly ventilated and well lit.

Table of Contents

Introduction

Important Information	<i>ii</i>
Serial Number Information	<i>ii</i>
Serial Number Legend	<i>iii</i>

Section 1

Safety Rules

General Safety Rules	<i>v</i>
----------------------------	----------

Section 2

Rev

Specifications

A	Machine Specifications	2 - 1
	Performance Specifications	2 - 2
	Hydraulic Oil Specifications	2 - 3
	Hydraulic Component Specifications	2 - 4
	Manifold Component Specifications	2 - 5
	Machine Torque Specifications	2 - 5
	Kubota D-905 Engine Specifications	2 - 6
	Kubota DF-752 Engine Specifications	2 - 7
	Perkins 403C-11 Engine Specifications	2 - 8
	Hydraulic Hose and Fitting Torque Specifications	2 - 9
	SAE and Metric Fastener Torque Charts	2 - 10

 TABLE OF CONTENTS

Section 3	Rev	Scheduled Maintenance Procedures	
		Introduction	3 - 1
		Pre-Delivery Preparation	3 - 3
		Maintenance Inspection Report	3 - 5
A		Checklist A Procedures	
	A-1	Inspect the Manuals and Decals	3 - 7
	A-2	Perform Pre-operation Inspection	3 - 8
	A-3	Perform Function Tests	3 - 8
	A-4	Perform Engine Maintenance	3 - 9
	A-5	Perform 30 Day Service	3 - 9
	A-6	Inspect the Engine Air Filter	3 - 10
	A-7	Perform Engine Maintenance - Kubota Models	3 - 11
	A-8	Perform Engine Maintenance - Kubota Models	3 - 11
	A-9	Perform Engine Maintenance - Kubota Models	3 - 12
	A-10	Grease the Turntable Rotation Bearing and Worm Drive Gear	3 - 12
	A-11	Perform Engine Maintenance - Kubota Models	3 - 13
	A-12	Drain the Fuel Filter/Water Separator - Diesel Models	3 - 14
A		Checklist B Procedures	
	B-1	Check the Engine Choke - Gasoline/LPG Models	3 - 16
	B-2	Check the Exhaust System	3 - 17
	B-3	Inspect the Battery	3 - 17
	B-4	Inspect the Electrical Wiring	3 - 19
	B-5	Inspect the Tires, Wheels and Lug Nut Torque	3 - 19
	B-6	Confirm the Proper Brake Configuration	3 - 20
	B-7	Check the Oil Level in the Drive Hubs	3 - 20
	B-8	Perform Engine Maintenance - Perkins 403C-11 Models	3 - 21
	B-9	Check and Adjust the Engine RPM	3 - 21
	B-10	Test the Ground Control Override	3 - 23
	B-11	Test the Platform Self-leveling	3 - 24

Section 3	Rev	Scheduled Maintenance Procedures, continued	
	B-12	Test the Engine Idle Select	3 - 24
	B-13	Test the Fuel Select Operation - Gasoline/LPG Models	3 - 25
	B-14	Test the Drive Brakes	3 - 26
	B-15	Test the Drive Speed - Stowed Position	3 - 27
	B-16	Test the Drive Speed - Raised or Extended Position	3 - 28
	B-17	Inspect the Fuel and Hydraulic Tank Cap Venting Systems	3 - 29
	B-18	Perform Hydraulic Oil Analysis	3 - 30
	B-19	Test the Alarm Package (if equipped)	3 - 30
	B-20	Replace the Diesel Fuel Filter/Water Separator Element - Diesel Models	3 - 31
	B-21	Perform Engine Maintenance - Kubota D905 Models	3 - 33
A		Checklist C Procedures	
	C-1	Grease the Platform Overload Mechanism (if equipped)	3 - 34
	C-2	Test the Platform Overload System (if equipped)	3 - 34
	C-3	Clean the Fuel Tank - Diesel Models	3 - 37
	C-4	Perform Engine Maintenance - Diesel Models	3 - 38
	C-5	Perform Engine Maintenance - Kubota D905 Models	3 - 38
A		Checklist D Procedures	
	D-1	Check the Primary Boom Wear Pads	3 - 39
	D-2	Check the Free-wheel Configuration	3 - 39
	D-3	Replace the Drive Hub Oil	3 - 40
	D-4	Replace the Hydraulic Filters	3 - 41
	D-5	Check the Turntable Rotation Bearing Bolts	3 - 42
	D-6	Inspect for Turntable Bearing Wear	3 - 43
	D-7	Perform Engine Maintenance	3 - 44
A		Checklist E Procedures	
	E-1	Test or Replace the Hydraulic Oil	3 - 45
	E-2	Grease the Steer Axle Wheel Bearings, 2WD Models	3 - 46
	E-3	Perform Engine Maintenance	3 - 48
	E-4	Perform Engine Maintenance - Perkins 403C-11 Models	3 - 48

 TABLE OF CONTENTS

Section 4	Rev	Repair Procedures	
		Introduction	4 - 1
	A	Platform Controls	
		1-1 Drive Joystick	4 - 2
		1-2 Boom Function Speed Controller	4 - 5
	A	Platform Components	
		2-1 Platform Leveling Slave Cylinder	4 - 6
		2-2 Platform Rotator	4 - 7
		2-3 Platform Overload System (if equipped)	4 - 9
	A	Jib Boom Components	
		3-1 Jib Boom	4 - 11
		3-2 Jib Boom Bell Crank	4 - 12
		3-3 Jib Boom Lift Cylinder	4 - 12
	A	Primary Boom Components	
		4-1 Plastic Cable Track	4 - 14
		4-2 Primary Boom	4 - 14
		4-3 Primary Boom Lift Cylinder	4 - 18
		4-4 Extension Cylinder	4 - 19
		4-5 Platform Leveling Master Cylinder	4 - 21
	A	Secondary Boom Components	
		5-1 Secondary Boom	4 - 25
		5-2 Secondary Boom Lift Cylinder	4 - 29
	A	Kubota D-905 Engine	
		6-1 Timing Adjustment	4 - 30
		6-2 Glow Plugs	4 - 30
		6-3 RPM Adjustment	4 - 30
		6-4 Flex Plate	4 - 30
		6-5 Coolant Temperature and Oil Pressure Switches	4 - 31

Section 4	Rev	Repair Procedures, continued	
	A	Kubota DF-752 Engine	
		7-1 Choke Adjustments	4 - 32
		7-2 Timing Adjustment	4 - 32
		7-3 Carburetor Adjustment	4 - 32
		7-4 RPM Adjustment	4 - 32
		7-5 Flex Plate	4 - 32
		7-6 Coolant Temperature and Oil Pressure Switches	4 - 33
	A	Perkins 403C-11 Engine	
		8-1 Timing Adjustment	4 - 34
		8-2 RPM Adjustment	4 - 34
		8-3 Flex Plate	4 - 34
		8-4 Coolant Temperature and Oil Pressure Switches	4 - 35
	A	Hydraulic Pumps	
		9-1 Auxiliary Pump	4 - 36
		9-2 Function Pump	4 - 37
		9-3 Drive Pump	4 - 38
	A	Manifolds	
		10-1 Function Manifold Components	4 - 40
		10-2 Valve Adjustments - Function Manifold	4 - 44
		10-3 Jib Boom / Platform Rotate Manifold Components	4 - 45
		10-4 Brake / 2-speed Manifold Components, 2WD Models	4 - 46
		10-5 2WD Traction Manifold Components	4 - 47
		10-6 4WD Traction Manifold Components	4 - 48
		10-7 Valve Adjustments - Traction Manifold	4 - 50
		10-8 Valve Coils	4 - 51

 TABLE OF CONTENTS

Section 4	Rev	Repair Procedures, continued	
	A	Fuel and Hydraulic Tanks	
		11-1 Fuel Tank	4 - 53
		11-2 Hydraulic Tank	4 - 54
	A	Turntable Rotation Components	
		12-1 Rotation Hydraulic Motor	4 - 55
	A	Axle Components	
		13-1 Hub and Bearings, 2WD Models	4 - 56
<hr/>			
Section 5	Rev	Schematics	
		Introduction	5 - 1
	A	Electrical Symbols Legend	5 - 2
	A	Hydraulic Symbols Legend	5 - 3
	A	Electrical Schematic - Diesel Models (from serial number 3242 to 3577)	5 - 5
	A	Electrical Schematic - Diesel Models (from serial number 3578 to 4799)	5 - 7
	A	Electrical Schematic - Gasoline/LPG Models (from serial number 3242 to 3577)	5 - 9
	A	Electrical Schematic - Gasoline/LPG Models (from serial number 3578 to 4799)	5 - 11

TABLE OF CONTENTS

Section 5	Rev	Schematics, continued	
	A	Ground Control Box Wiring Diagram - Diesel Models (from serial number 3242 to 3308)	5 - 17
	A	Ground Control Box Wiring Diagram - Diesel Models (from serial number 3309 to 3577)	5 - 18
	A	Ground Control Box Wiring Diagram - Diesel Models (from serial number 3578 to 4799)	5 - 19
	A	Ground Control Box Wiring Diagram - Gasoline/LPG Models (from serial number 3242 to 3308)	5 - 20
	A	Ground Control Box Wiring Diagram - Gasoline/LPG Models (from serial number 3309 to 3577)	5 - 21
	A	Ground Control Box Wiring Diagram - Gasoline/LPG Models (from serial number 3578 to 4799)	5 - 22
	A	Platform Control Box Wiring Diagram - Diesel Models (from serial number 3242 to 3577)	5 - 23
	A	Platform Control Box Wiring Diagram - Diesel Models (from serial number 3578 to 4799)	5 - 24
	A	Platform Control Box Wiring Diagram - Gasoline/LPG Models (from serial number 3242 to 3577)	5 - 25
	A	Platform Control Box Wiring Diagram - Gasoline/LPG Models (from serial number 3578 to 4799)	5 - 26
	A	Generator Option Wiring Diagram (from serial number 3242 to 4081)	5 - 27
	A	Generator Option Wiring Diagram (from serial number 4082 to 4799)	5 - 28
	A	Load Sense Option Wiring Diagram (from serial number 3242 to 3577)	5 - 29
	A	Manifold and Limit Switch Wiring	5 - 30
	A	Hydraulic Schematic, 2WD Models	5 - 31
	A	Hydraulic Schematic, 4WD Models	5 - 33

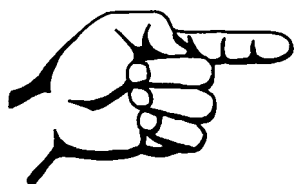

This page intentionally left blank.

Specifications

REV A

Machine Specifications

Tires and wheels	Rough terrain	Industrial
Tire size	10-16.5 NHS	9-14.5 LT
Tire ply rating		Tread 6 Sidewall 6
Overall tire diameter	30.5 in 77.5 cm	28 in 71.1 cm
Wheel diameter	16.5 in 42 cm	14.5 in 36.8 cm
Wheel width	10 in 25.4 cm	7 in 18 cm
Wheel lugs, 4WD	9 @ 5/8-18	
Wheel lugs, 2WD		
Front	8 @ 5/8-18	8 @ 5/8-18
Rear	9 @ 5/8-18	9 @ 5/8-18
Tire pressure	45 psi 3.1 bar	100 psi 6.89 bar
Lug nut torque (lubricated)	125 ft-lbs 170 Nm	125 ft-lbs 170 Nm

Fluid capacities

Fuel tank capacity	9.3 gallons 35.2 liters
Hydraulic tank capacity	18 gallons 68.1 liters
Hydraulic system capacity (including tank)	22 gallons 83.3 liters
Drive hubs	17 fl oz 0.5 liter
Drive hub oil type:	EP 80-90W gear oil API service classification GL5

For operational specifications, refer to the Operator's Manual.

Continuous improvement of our products is a Genie policy. Product specifications are subject to change without notice.

SPECIFICATIONS

REV A

Performance Specifications**Drive speeds, maximum (before serial number 3578)**

	2WD	4WD
Boom stowed, high range	4.5 mph 7.2 km/h 40 ft/6.1 sec 12.2 m/6.1 sec	4.0 mph 6.4 km/h 40 ft/6.8 sec 12.2 m/6.8 sec
Boom raised or extended	0.6 mph 1km/h 40 ft/40 sec 12.2 m/40 sec	0.6 mph 1km/h 40 ft/40 sec 12.2 m/40 sec

Drive speeds, maximum (after serial number 3577)

	2WD	4WD
Boom stowed, high range	4.0 mph 6.4 km/h 40 ft/6.8 sec 12.2 m/6.8 sec	3.5 mph 5.6 km/h 40 ft/7.8 sec 12.2 m/7.8 sec
Boom raised or extended	0.6 mph 1km/h 40 ft/40 sec 12.2 m/40 sec	0.6 mph 1km/h 40 ft/40 sec 12.2 m/40 sec

Braking distance, maximum on paved surface 3 to 4 ft
0.9 to 1.2 m

Gradeability See Operator's Manual

Boom function speeds, maximum from platform controls (with rated load in platform)

Jib boom up	24 to 30 seconds
Jib boom down	15 to 21 seconds
Primary boom up	15 to 21 seconds
Primary boom down	13 to 19 seconds
Primary boom extend	24 to 30 seconds
Primary boom retract	14 to 20 seconds
Secondary boom up	15 to 21 seconds
Secondary boom down	11 to 17 seconds
Turntable rotate, 355°	62 to 68 seconds
Platform rotate, 160°	4 to 7 seconds

Continuous improvement of our products is a Genie policy. Product specifications are subject to change without notice.

REV A

SPECIFICATIONS

Hydraulic Oil Specifications

Hydraulic Oil Specifications

Before serial number 3335

Hydraulic oil type Shell Donax TG (Dexron III)

After serial number 3334

Hydraulic oil type Chevron Rykon MV equivalent

Viscosity grade Multi-viscosity

Viscosity index 200

Cleanliness level, minimum 15/13

Water content, maximum 200 ppm

Chevron Rykon MV oil is fully compatible and mixable with Shell Donax TG (Dexron III) oils.

Genie specifications require hydraulic oils which are designed to give maximum protection to hydraulic systems, have the ability to perform over a wide temperature range, and the viscosity index should exceed 140. They should provide excellent antiwear, oxidation, corrosion inhibition, seal conditioning, and foam and aeration suppression properties.

Optional fluids

Biodegradable Petro Canada Environ MV46
Statoil Hydra Way Bio Pa 32
BP Biohyd SE-S

Fire resistant UCON Hydrolube HP-5046
Quintolubric 822

Mineral based Shell Tellus T32
Shell Tellus T46
Chevron Aviation A

NOTICE

Continued use of Chevron Aviation A hydraulic fluid when ambient temperatures are consistently above 32°F / 0°C may result in component damage.

Note: Use Chevron Aviation A hydraulic fluid when ambient temperatures are consistently below 0°F / -18°C.

Note: Use Shell Tellus T46 hydraulic oil when oil temperatures consistently exceed 205°F / 96°C.

Note: Genie specifications require additional equipment and special installation instructions for the approved optional fluids. Consult the Genie Industries Service Department before use.

SPECIFICATIONS

REV A

Hydraulic Component Specifications

Drive pump

Type: bi-directional variable displacement piston pump

Displacement per revolution 1.71 cu in
28 cc

Flow rate @ 3000rpm 22 gpm
84 L/min

Function pump

Type: Fixed displacement gear pump

Displacement per revolution 0.24 cu in
4 cc

Flow rate @ 3000rpm 3 gpm
11.4 L/min

Auxiliary pump

Type: Fixed displacement gear pump

Displacement 0.5 gpm
1.9 L/min

Auxiliary pump relief pressure 3400 psi
234.5 bar

Front drive motors, 4WD models

Displacement per revolution (before serial number 3734) 1.83 cu in
30 cc

Displacement per revolution (after serial number 3733) 1.53 cu in
25 cc

Rear drive motors, all models

Displacement per revolution (before serial number 3734) 1.83 cu in
30 cc

Displacement per revolution (after serial number 3733) 1.53 cu in
25 cc

Function manifold

System relief valve pressure 3200 psi
220.7 bar

Primary boom down relief valve pressure 1600 psi
110 bar

Secondary boom down relief valve pressure 1600 psi
110 bar

Traction manifold

Hot oil shuttle relief pressure 2WD models 170 psi
11.7 bar

4WD models 150 psi
10.3 bar

Hydraulic filters

Hydraulic tank return line filter Beta 10 \geq 200
with 25 psi / 1.7 bar bypass

Medium pressure filter Beta 3 \geq 200

Medium pressure filter bypass pressure 50 psi
3.45 bar

Continuous improvement of our products is a Genie policy. Product specifications are subject to change without notice.

REV A

SPECIFICATIONS

Manifold Component Specifications

Plug torque

SAE No. 2	36 in-lbs / 4 Nm
SAE No. 4	10 ft-lbs / 13 Nm
SAE No. 6	14 ft-lbs / 19 Nm
SAE No. 8	38 ft-lbs / 51 Nm
SAE No. 10	41 ft-lbs / 55 Nm
SAE No. 12	56 ft-lbs / 76 Nm

Valve Coil Resistance

Note: The following coil resistance specifications are at an ambient temperature of 68°F / 20°C. As valve coil resistance is sensitive to changes in air temperature, the coil resistance will typically increase or decrease by 4% for each 18°F / 20°C that your air temperature increases or decreases from 68°F / 20°C.

Valve coil specifications

2 position 3 way solenoid valve, 10V DC (schematic items L, M, N, O, P, Q, R, S, T, U, AA, AB, BA and BB)	6Ω
3 position 4 way solenoid valve, 10V DC (schematic item E, CH, CI)	6Ω
Proportional solenoid valve, 12V DC (schematic item D)	5Ω

Machine Torque Specifications

Platform rotator

3/4 -10 center bolt, GR 8 (dry)	380 ft-lbs 515 Nm
3/4 -10 center bolt, GR 8 (lubricated)	280 ft-lbs 379 Nm
3/8 -16 bolts, GR 8 (dry)	44 ft-lbs 60 Nm
3/8 -16 bolts, GR 8 (lubricated)	33 ft-lbs 45 Nm

Turntable rotate assembly

Rotate bearing mounting bolts, lubricated	180 ft-lbs 244 Nm
Rotate bearing motor mounting bolts, lubricated	93 ft-lbs 126 Nm

Drive motor and hubs

Drive hub mounting bolts, lubricated	180 ft-lbs 244 Nm
Drive motor mounting bolts, lubricated 3/8 -16, GR 5	23 ft-lbs 31 Nm
7/16 -14, GR 5	37 ft-lbs 50 Nm

Continuous improvement of our products is a Genie policy. Product specifications are subject to change without notice.



SPECIFICATIONS

REV A

Kubota D-905 Engine

Displacement	54.86 cu in 0.90 liters
Number of cylinders	3
Bore and stroke	2.83 x 2.90 inches 72 x 73.6 mm
Horsepower, gross intermittent	26 @ 3600 rpm 19.3kW
Firing order	1 - 2 - 3
Compression ratio	23:1
Compression pressure	412 to 469 psi 28.4 to 32.3 bar
Low idle	1300 rpm
Frequency	260 hz
High idle	3000 rpm
Frequency	600 hz
Governor	centrifugal mechanical
Valve clearance, cold	0.0057 to 0.0072 in 0.145 to 0.183 mm
Engine coolant	
Capacity	3.3 quarts 3.1 liters

Lubrication system

Oil pressure	36 to 64 psi 2.48 to 4.41 bar
Oil capacity (including filter)	5.4 quarts 5.1 liters

Oil viscosity requirements

Units ship with 15W-40.
Extreme operating temperatures may require the use of alternative engine oils. For oil requirements, refer to the Engine Operator Handbook on your machine.

Injection system

Injection pump make	Bocsh MD
Injection timing	13° to 25° BTDC
Injection pump pressure	1991 psi 137 bar

Fuel requirement

For fuel requirements, refer to the engine Operator's Manual on your machine.

Battery

Type	12V DC
Group	34/78
Quantity	1
Ampere hour	75AH
Cold cranking ampere	900A
Reserve capacity @ 25A rate	125 minutes

Alternator

Output	30A, 14V DC
Fan belt deflection	$\frac{1}{4}$ to $\frac{3}{8}$ inch 7 to 9 mm

Continuous improvement of our products is a Genie policy. Product specifications are subject to change without notice.

REV A

SPECIFICATIONS

Kubota DF-752 Engine

Displacement	45.21 cu in 0.74 liters
Number of cylinders	3
Bore & stroke	2.68 x 2.68 inches 68 x 68 mm
Horsepower, gross intermittent	24.8 @ 3600 rpm 18.5 kW @ 3600 rpm
Firing order	1 - 2 - 3
Low idle	1600 rpm 320 hz
High idle	3000 rpm 600 hz
Governor	centrifugal ball mechanical
Compression ratio	9.2:1
Compression pressure (approx.)	128 to 185 psi 8.8 to 12.7 bar
Valve clearances, cold	0.0057 to 0.0072 inches 0.145 to 0.183 mm
Lubrication system	
Oil pressure (operating temp. @ 3850 rpm)	28 to 64 psi 1.9 to 4.4 bar
Oil capacity (including filter)	3.4 quarts 3.25 liters
Oil viscosity requirements	
Units ship with 15W-40. Extreme operating temperatures may require the use of alternative engine oils. For oil requirements, refer to the Engine Operator Handbook on your machine.	
Fuel pump	
Fuel pressure, static	2.84 psi 0.19 bar
Fuel flow rate	0.125 gpm 0.47 L/min

Continuous improvement of our products is a Genie policy. Product specifications are subject to change without notice.

Starter motor

Brush length, new	0.669 in 17 mm
Brush length wear limit	0.453 in 11.5 mm
Brush spring tension	50 to 91 ounces 13.9 to 25.3 Newtons

Battery

Type	12V DC
Group	34/78
Quantity	1
Ampere hour	75AH
Cold cranking ampere	900A
Reserve capacity @ 25A rate	125 minutes

Ignition System

Ignition spark advance	18° BTDC
Ignition coil primary resistance	1.3 to 1.6Ω @ 75°F / 24°C
Ignition coil secondary resistance	10.7 to 14.5 kΩ @ 75°F / 24°C
#1 Spark plug wire resistance	2.81 to 4.79 kΩ
#2 Spark plug wire resistance	3.4 to 5.8 kΩ
#3 Spark plug wire resistance	3.57 to 6.09 kΩ
Spark plug type	NGK BKR4E-11
Spark plug gap	0.039 to 0.043 inches 1 to 1.1 mm

Engine coolant

Capacity	3.1 quarts 2.9 liters
----------	--------------------------

Alternator

Output	30A, 14V DC
Fan belt deflection	1/4 to 3/8 inch 7 to 9 mm

SPECIFICATIONS

REV A

Perkins 403C-11 Engine

Displacement	68.9 cu in 1.13 liters
---------------------	---------------------------

Number of cylinders	3
----------------------------	---

Bore and stroke	3.03 x 3.19 inches 77 x 81 mm
------------------------	----------------------------------

Horsepower, gross intermittent	26.1 @ 3000 rpm 19.5 kW
---------------------------------------	----------------------------

Firing order	1 - 2 - 3
---------------------	-----------

Compression ratio	23:1
--------------------------	------

Compression pressure	425 psi 29.3 bar
-----------------------------	---------------------

Pressure of the lowest cylinder must be within 50 psi / 3.45 bar of the highest cylinder, though at no time less than 360 psi / 24.8 bar

Low idle	1500 rpm
Frequency	300 hz

High idle	3000 rpm
Frequency	600 hz

Governor	all-speed mechanical
-----------------	----------------------

Valve clearance, cold	0.0078 in 0.2 mm
------------------------------	---------------------

Engine coolant capacity	3.28 quarts 3.1 liters
--------------------------------	---------------------------

Engine coolant should be clean soft water with 50% anti freeze concentration ethylene glycol to BS 6580:1992 or ASTM D 3306-89 or AS 2108-1977

Lubrication system

Oil pressure	40 to 60 psi
(hot @ 2000 rpm)	2.76 to 4.14 bar

Oil capacity (including filter)	4.3 quarts 4.07 liters
---------------------------------	---------------------------

Oil viscosity requirements

Units ship with 15W-40.

Extreme operating temperatures may require the use of alternative engine oils. For oil requirements, refer to the Engine Operator Handbook on your machine.

Injection system

Injection pump make	Bosch
---------------------	-------

Injection timing	23° BTDC @ 3000 rpm
------------------	---------------------

Injection pump pressure	2133 psi 147 bar
-------------------------	---------------------

Fuel requirement	diesel number 2-D
-------------------------	-------------------

Battery

Type	12V DC
------	--------

Group	34/78
-------	-------

Quantity	1
----------	---

Ampere hour	75AH
-------------	------

Cold cranking ampere	900A
----------------------	------

Reserve capacity @ 25A rate	125 minutes
-----------------------------	-------------

Alternator

Output	40A, 12V DC
--------	-------------

Fan belt deflection	³ / ₁₆ inch 5 mm
---------------------	---

Continuous improvement of our products is a Genie policy. Product specifications are subject to change without notice.

REV A

SPECIFICATIONS

Hydraulic Hose and Fitting Torque Specifications

Your machine is equipped with Parker Seal-Lok® fittings and hose ends. Genie specifications require that fittings and hose ends be torqued to specification when they are removed and installed or when new hoses or fittings are installed.

SAE O-ring Boss Port

(tube fitting - installed into Aluminum)

SAE Dash size	Torque
-4	11 ft-lbs / 14.9 Nm
-6	23 ft-lbs / 31.2 Nm
-8	40 ft-lbs / 54.2 Nm
-10	69 ft-lbs / 93.6 Nm
-12	93 ft-lbs / 126.1 Nm
-16	139 ft-lbs / 188.5 Nm
-20	172 ft-lbs / 233.2 Nm
-24	208 ft-lbs / 282 Nm

SAE O-ring Boss Port

(tube fitting - installed into Steel)

SAE Dash size	Torque
-4	16 ft-lbs / 21.7 Nm
-6	35 ft-lbs / 47.5 Nm
-8	60 ft-lbs / 81.3 Nm
-10	105 ft-lbs / 142.4 Nm
-12	140 ft-lbs / 190 Nm
-16	210 ft-lbs / 284.7 Nm
-20	260 ft-lbs / 352.5 Nm
-24	315 ft-lbs / 427.1 Nm

Seal-Lok® fittings

- 1 Replace the O-ring. The O-ring must be replaced anytime the seal has been broken. The O-ring cannot be re-used if the fitting or hose end has been tightened beyond finger tight.

Note: The O-rings used in the Parker Seal Lok® fittings and hose ends are custom-size O-rings. They are not standard SAE size O-rings. They are available in the O-ring field service kit (Genie part number 49612).

- 2 Lubricate the O-ring before installation.
- 3 Be sure that the face seal O-ring is seated and retained properly.
- 4 Position the tube and nut squarely on the face seal end of the fitting and tighten the nut finger tight.
- 5 Tighten the nut or fitting to the appropriate torque per given size as shown in the table.
- 6 Operate all machine functions and inspect the hoses and fittings and related components to confirm that there are no leaks.



Seal-Lok® Fittings





(hose end)

SAE Dash size	Torque
-4	18 ft-lbs / 25 Nm
-6	30 ft-lbs / 40 Nm
-8	40 ft-lbs / 55 Nm
-10	60 ft-lbs / 80 Nm
-12	85 ft-lbs / 115 Nm
-16	110 ft-lbs / 150 Nm
-20	140 ft-lbs / 190 Nm
-24	180 ft-lbs / 245 Nm

SPECIFICATIONS

REV A

SAE FASTENER TORQUE CHART											
• This chart is to be used as a guide only unless noted elsewhere in this manual •											
SIZE	THREAD	Grade 5 				Grade 8 				A574 High Strength Black Oxide Bolts	
		LUBED		DRY		LUBED		DRY		LUBED	
		in-lbs	Nm	in-lbs	Nm	in-lbs	Nm	in-lbs	Nm	in-lbs	Nm
1/4	20	80	9	100	11.3	110	12.4	140	15.8	130	14.7
	28	90	10.1	120	13.5	120	13.5	160	18	140	15.8
		LUBED		DRY		LUBED		DRY		LUBED	
		ft-lbs	Nm	ft-lbs	Nm	ft-lbs	Nm	ft-lbs	Nm	ft-lbs	Nm
5/16	18	13	17.6	17	23	18	24	25	33.9	21	28.4
	24	14	19	19	25.7	20	27.1	27	36.6	24	32.5
3/8	16	23	31.2	31	42	33	44.7	44	59.6	38	51.5
	24	26	35.2	35	47.4	37	50.1	49	66.4	43	58.3
7/16	14	37	50.1	49	66.4	50	67.8	70	94.7	61	82.7
	20	41	55.5	55	74.5	60	81.3	80	108.4	68	92.1
1/2	13	57	77.3	75	101.6	80	108.4	110	149	93	126
	20	64	86.7	85	115	90	122	120	162	105	142
9/16	12	80	108.4	110	149	120	162	150	203	130	176
	18	90	122	120	162	130	176	170	230	140	189
5/8	11	110	149	150	203	160	217	210	284	180	244
	18	130	176	170	230	180	244	240	325	200	271
3/4	10	200	271	270	366	280	379	380	515	320	433
	16	220	298	300	406	310	420	420	569	350	474
7/8	9	320	433	430	583	450	610	610	827	510	691
	14	350	474	470	637	500	678	670	908	560	759
1	8	480	650	640	867	680	922	910	1233	770	1044
	12	530	718	710	962	750	1016	990	1342	840	1139
1 1/8	7	590	800	790	1071	970	1315	1290	1749	1090	1477
	12	670	908	890	1206	1080	1464	1440	1952	1220	1654
1 1/4	7	840	1138	1120	1518	1360	1844	1820	2467	1530	2074
	12	930	1260	1240	1681	1510	2047	2010	2725	1700	2304
1 1/2	6	1460	1979	1950	2643	2370	3213	3160	4284	2670	3620
	12	1640	2223	2190	2969	2670	3620	3560	4826	3000	4067

METRIC FASTENER TORQUE CHART																
• This chart is to be used as a guide only unless noted elsewhere in this manual •																
Size (mm)	Class 4.6 				Class 8.8 				Class 10.9 				Class 12.9 			
	LUBED		DRY		LUBED		DRY		LUBED		DRY		LUBED		DRY	
	in-lbs	Nm	in-lbs	Nm	in-lbs	Nm	in-lbs	Nm	in-lbs	Nm	in-lbs	Nm	in-lbs	Nm	in-lbs	Nm
5	16	1.8	21	2.4	41	4.63	54	6.18	58	6.63	78	8.84	68	7.75	91	10.3
6	19	3.05	36	4.07	69	7.87	93	10.5	100	11.3	132	15	116	13.2	155	17.6
7	45	5.12	60	6.83	116	13.2	155	17.6	167	18.9	223	25.2	1.95	22.1	260	29.4
	LUBED		DRY		LUBED		DRY		LUBED		DRY		LUBED		DRY	
	ft-lbs	Nm	ft-lbs	Nm	ft-lbs	Nm	ft-lbs	Nm	ft-lbs	Nm	ft-lbs	Nm	ft-lbs	Nm	ft-lbs	Nm
8	5.4	7.41	7.2	9.88	14	19.1	18.8	25.5	20.1	27.3	26.9	36.5	23.6	32	31.4	42.6
10	10.8	14.7	14.4	19.6	27.9	37.8	37.2	50.5	39.9	54.1	53.2	72.2	46.7	63.3	62.3	84.4
12	18.9	25.6	25.1	34.1	48.6	66	64.9	88	69.7	94.5	92.2	125	81	110	108	147
14	30.1	40.8	40	54.3	77.4	105	103	140	110	150	147	200	129	175	172	234
16	46.9	63.6	62.5	84.8	125	170	166	226	173	235	230	313	202	274	269	365
18	64.5	87.5	86.2	117	171	233	229	311	238	323	317	430	278	377	371	503
20	91	124	121	165	243	330	325	441	337	458	450	610	394	535	525	713
22	124	169	166	225	331	450	442	600	458	622	612	830	536	727	715	970
24	157	214	210	285	420	570	562	762	583	791	778	1055	682	925	909	1233



Scheduled Maintenance Procedures



Observe and Obey:

- ☑ Maintenance inspections shall be completed by a person trained and qualified on the maintenance of this machine.
- ☑ Scheduled maintenance inspections shall be completed daily, quarterly, semi-annually, annually and every 2 years as specified on the *Maintenance Inspection Report*.

AWARNING Failure to perform each procedure as presented and scheduled could result in death, serious injury or substantial machine damage.

- ☑ Immediately tag and remove from service a damaged or malfunctioning machine.
- ☑ Repair any machine damage or malfunction before operating the machine.
- ☑ Use only Genie approved replacement parts.
- ☑ Machines that have been out of service for a period longer than 3 months must complete the quarterly inspection.
- ☑ Unless otherwise specified, perform each procedure with the machine in the following configuration:
 - Machine parked on a firm, level surface
 - Boom in the stowed position
 - Turntable rotated with the boom between the non-steer wheels
 - Key switch in the off position with the key removed
 - Wheels chocked
 - All external AC power supply disconnected from the machine

About This Section

This section contains detailed procedures for each scheduled maintenance inspection.

Each procedure includes a description, safety warnings and step-by-step instructions.

Symbols Legend



Safety alert symbol—used to alert personnel to potential personal injury hazards. Obey all safety messages that follow this symbol to avoid possible injury or death.



Indicates an imminently hazardous situation which, if not avoided, will result in death or serious injury.



Indicates a potentially hazardous situation which, if not avoided, could result in death or serious injury.



Indicates a potentially hazardous situation which, if not avoided, may cause minor or moderate injury.



Indicates a potentially hazardous situation which, if not avoided, may result in property damage.

⦿ Indicates that a specific result is expected after performing a series of steps.

⊗ Indicates that an incorrect result has occurred after performing a series of steps.

SCHEDULED MAINTENANCE PROCEDURES

Maintenance Symbols Legend

The following symbols have been used in this manual to help communicate the intent of the instructions. When one or more of the symbols appear at the beginning of a maintenance procedure, it conveys the meaning below.



Indicates that tools will be required to perform this procedure.



Indicates that new parts will be required to perform this procedure.



Indicates that a cold engine will be required to perform this procedure.



Indicates that a warm engine will be required to perform this procedure.



Indicates that dealer service will be required to perform this procedure.

Pre-delivery Preparation Report

The pre-delivery preparation report contains checklists for each type of scheduled inspection.

Make copies of the *Pre-delivery Preparation* report to use for each inspection. Store completed forms as required.

Maintenance Schedule

There are five types of maintenance inspections that must be performed according to a schedule—daily, quarterly, semi-annually, annual and two year. The *Scheduled Maintenance Procedures Section* and the *Maintenance Inspection Report* have been divided into five subsections—A, B, C, D and E. Use the following chart to determine which group(s) of procedures are required to perform a scheduled inspection.

Inspection	Checklist
Daily or every 8 hours	A
Quarterly or every 250 hours	A + B
Semi-annually or every 500 hours	A + B + C
Annually or every 1000 hours	A + B + C + D
Two years or every 2000 hours	A + B + C + D + E

Maintenance Inspection Report

The maintenance inspection report contains checklists for each type of scheduled inspection.

Make copies of the *Maintenance Inspection Report* to use for each inspection. Store completed forms for three years.

Pre-Delivery Preparation

Fundamentals

It is the responsibility of the dealer to perform the Pre-delivery Preparation.

The Pre-delivery Preparation is performed prior to each delivery. The inspection is designed to discover if anything is apparently wrong with a machine before it is put into service.

A damaged or modified machine must never be used. If damage or any variation from factory delivered condition is discovered, the machine must be tagged and removed from service.

Repairs to the machine may only be made by a qualified service technician, according to the manufacturer's specifications.

Scheduled maintenance inspections shall be performed by qualified service technicians, according to the manufacturer's specifications and the requirements listed in the responsibilities manual.

Instructions

Use the operator's manual on your machine.

The Pre-delivery Preparation consists of completing the Pre-operation Inspection, the Maintenance items and the Function Tests.

Use this form to record the results. Place a check in the appropriate box after each part is completed. Follow the instructions in the operator's manual.

If any inspection receives an N, remove the machine from service, repair and re-inspect it. After repair, place a check in the R box.

Legend

Y = yes, completed

N = no, unable to complete

R = repaired

Comments

Pre-Delivery Preparation	Y	N	R
Pre-operation inspection completed			
Maintenance items completed			
Function tests completed			

Model

Serial number

Date

Machine owner

Inspected by (print)

Inspector signature

Inspector title

Inspector company



Genie Industries USA
18340 NE 76th Street
PO Box 97030
Redmond, WA 98073-9730
(425) 881-1800

Genie UK
The Maltings, Wharf Road
Grantham, Lincolnshire
NG31-6BH England
(44) 1476-584333

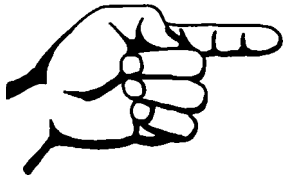

This page intentionally left blank.

Maintenance Inspection Report

Model
Serial number
Date
Hour meter
Machine owner
Inspected by (print)
Inspector signature
Inspector title
Inspector company

Instructions

- Make copies of this page to use for each inspection.
- Select the appropriate checklist(s) for the type of inspection to be performed.

<input type="checkbox"/>	Daily or 8 hour Inspection:	A
<input type="checkbox"/>	Quarterly or 250 hour Inspection:	A+B
<input type="checkbox"/>	Semi-annually or 500 hour Inspection:	A+B+C
<input type="checkbox"/>	Annual or 1000 hours Inspection:	A+B+C+D
<input type="checkbox"/>	2 Year or 2000 hour Inspection:	A+B+C+D+E

- Place a check in the appropriate box after each inspection procedure is completed.
- Use the step-by-step procedures in this section to learn how to perform these inspections.
- If any inspection receives an "N", tag and remove the machine from service, repair and re-inspect it. After repair, place a check in the "R" box.

Legend

- Y = yes, acceptable
- N = no, remove from service
- R = repaired

Checklist A - Rev A		Y	N	R
A-1	Manuals and decals			
A-2	Pre-operation inspection			
A-3	Function tests			
A-4	Engine maintenance			
Perform after 40 hours:				
A-5	30 Day Service			
Perform every 40 hours:				
A-6	Engine air filter			
Perform after 50 hours:				
A-7	Engine maintenance - Kubota models			
Perform every 50 hours:				
A-8	Engine maintenance - Kubota models			
Perform every 100 hours:				
A-9	Engine maintenance - Kubota models			
A-10	Grease rotation bearing			
Perform every 200 hours:				
A-11	Engine maintenance - Kubota models			
A-12	Fuel filter/water separator - Diesel models			

Checklist B - Rev A		Y	N	R
B-1	Engine choke - Gasoline/LPG models			
B-2	Exhaust system			
B-3	Battery			
B-4	Electrical wiring			
B-5	Tires, wheels and lug nut torque			
B-6	Brake configuration			
B-7	Drive hub oil level			
B-8	Engine maintenance - Perkins models			
B-9	Engine RPM			
B-10	Ground control override			
B-11	Platform self leveling			
B-12	Engine idle select			
B-13	Fuel select - Gasoline/LPG models			
B-14	Drive brakes			
B-15	Drive speed - stowed			
B-16	Drive speed - raised or extended			
B-17	Fuel and hydraulic tank cap venting			
B-18	Hydraulic oil analysis			
B-19	Alarm package (if equipped)			
Perform every 400 hours:				
B-20	Replace fuel filter/ separator - Diesel models			
B-21	Engine maintenance - Kubota D905 models			

Comments

MAINTENANCE INSPECTION REPORT

Model _____

Serial number _____

Date _____

Hour meter _____

Machine owner _____

Inspected by (print) _____

Inspector signature _____

Inspector title _____

Inspector company _____

Instructions

- Make copies of this page to use for each inspection.
- Select the appropriate checklist(s) for the type of inspection to be performed.

	Daily or 8 hour Inspection:	A
	Quarterly or 250 hour Inspection:	A+B
	Semi-annually or 500 hour Inspection:	A+B+C
	Annual or 1000 hours Inspection:	A+B+C+D
	2 Year or 2000 hour Inspection:	A+B+C+D+E

- Place a check in the appropriate box after each inspection procedure is completed.
- Use the step-by-step procedures in this section to learn how to perform these inspections.
- If any inspection receives an “N”, tag and remove the machine from service, repair and re-inspect it. After repair, place a check in the “R” box.

Legend

Y = yes, acceptable
 N = no, remove from service
 R = repaired

Checklist C - Rev A		Y	N	R
C-1	Grease platform overload (if equipped)			
C-2	Test platform overload (if equipped)			
C-3	Clean fuel tank - Diesel models			
C-4	Engine maintenance - Diesel models			

Perform every 800 hours:

C-5	Engine maintenance - Kubota D905 models			
-----	---	--	--	--

Checklist D - Rev A		Y	N	R
D-1	Boom wear pads			
D-2	Free-wheel configuration			
D-3	Drive hub oil			
D-4	Replace hydraulic filters			
D-5	Turntable rotation bolts			
D-6	Turntable bearing wear			
D-7	Engine maintenance			

Checklist E - Rev A		Y	N	R
E-1	Replace hydraulic oil			
E-2	Grease wheel bearings, 2WD models			
E-3	Engine maintenance			

Perform every 3000 hours:

E-4	Engine maintenance - Perkins models			
-----	-------------------------------------	--	--	--

Comments

Checklist A Procedures

REV A

A-1 Inspect the Manuals and Decals

Note: Genie specifications require that this procedure be performed daily or every 8 hours, whichever comes first.

Maintaining the operator's and safety manuals in good condition is essential to safe machine operation. Manuals are included with each machine and should be stored in the container provided in the platform. An illegible or missing manual will not provide safety and operational information necessary for a safe operating condition.

In addition, maintaining all of the safety and instructional decals in good condition is mandatory for safe machine operation. Decals alert operators and personnel to the many possible hazards associated with using this machine. They also provide users with operation and maintenance information. An illegible decal will fail to alert personnel of a procedure or hazard and could result in unsafe operating conditions.

- 1 Check to make sure that the operator's and safety manuals are present and complete in the storage container on the platform.
 - 2 Examine the pages of each manual to be sure that they are legible and in good condition.
- ⦿ Result: The operator's manual is appropriate for the machine and all manuals are legible and in good condition.
 - ✘ Result: The operator's manual is not appropriate for the machine or all manuals are not in good condition or are illegible. Remove the machine from service until the manual is replaced.

- 3 Open the operator's manual to the decals inspection section. Carefully and thoroughly inspect all decals on the machine for legibility and damage.
- ⦿ Result: The machine is equipped with all required decals, and all decals are legible and in good condition.
 - ✘ Result: The machine is not equipped with all required decals, or one or more decals are illegible or in poor condition. Remove the machine from service until the decals are replaced.
- 4 Always return the manuals to the storage container after use.

Note: Contact your authorized Genie distributor or Genie Industries if replacement manuals or decals are needed.

CHECKLIST A PROCEDURES

REV A

A-2 Perform Pre-operation Inspection

Note: Genie specifications require that this procedure be performed every 8 hours or daily, whichever comes first.

Completing a pre-operation inspection is essential to safe machine operation. The pre-operation inspection is a visual inspection performed by the operator prior to each work shift. The inspection is designed to discover if anything is apparently wrong with a machine before the operator performs the function tests. The pre-operation inspection also serves to determine if routine maintenance procedures are required.

Complete information on how to perform this procedure is available in the appropriate *Genie Z-34/22 IC Operator's Manual* on your machine.

A-3 Perform Function Tests

Note: Genie specifications require that this procedure be performed every 8 hours or daily, whichever comes first.

Completing the function tests is essential to safe machine operation. Function tests are designed to discover any malfunctions before the machine is put into service. A malfunctioning machine must never be used. If malfunctions are discovered, the machine must be tagged and removed from service.

Complete information on how to perform this procedure is available in the appropriate *Genie Z-34/22 IC Operator's Manual* on your machine.

REV A

CHECKLIST A PROCEDURES

A-4 Perform Engine Maintenance



Note: Engine specifications require that this procedure be performed every 8 hours or daily, whichever comes first.

Required maintenance procedures and additional engine information is available in the *Kubota D905 Operator's Manual* (Kubota part number 16622-8916-5) OR the *Kubota DF752 Operator's Manual* (Kubota part number EG601-8916-1) OR the *Perkins 403C-11 User's Handbook* (Perkins part number 100816460).

Kubota D905 Operator's Manual	
Genie part number	31743
Kubota DF752 Operator's Manual	
Genie part number	84250
Perkins 403C-11 User's Handbook	
Genie part number	97360

A-5 Perform 30 Day Service



The 30 day maintenance procedure is a one-time sequence of procedures to be performed after the first 30 days or 40 hours of usage. After this interval, refer to the maintenance checklists for continued scheduled maintenance.

1 Perform the following maintenance procedures:

Kubota models:

- B-5 Inspect the Tires, Wheels and Lug Nut Torque
- C-5 Perform Engine Maintenance - Diesel Models
- D-4 Replace the Hydraulic Filters
- D-5 Check the Turnable Rotation Bearing Bolts

Perkins models:

- B-5 Inspect the Tires, Wheels and Lug Nut Torque
- B-8 Perform Engine Maintenance - Perkins 403C-11 Models
- D-4 Replace the Hydraulic Filters
- D-5 Check the Turnable Rotation Bearing Bolts

CHECKLIST A PROCEDURES

REV A

A-6**Inspect the Engine Air Filter**

Note: Genie specifications require that this procedure be performed every 40 hours or weekly, whichever comes first.

Maintaining the engine air filter in good condition is essential to good engine performance and service life. Failure to perform this procedure can lead to poor engine performance and component damage.

- 1 **Kubota D905 models:** Pull up on the engine pivot plate lock pin located under the pump. Swing the engine pivot plate out and away from the machine for access.
- 2 **Kubota D-905 models:** Remove the wingnut securing the end cap to the air cleaner canister. Remove the end cap.
All other models: Disconnect the retaining clamps securing the end cap to the air cleaner canister. Remove the end cap.
- 3 Remove the air filter element.
- 4 Clean the inside of the air filter canister and the canister gasket with a damp cloth.
- 5 Inspect for and remove any blockage or debris from the intake air passages.
- 6 Inspect the air filter element. If needed, blow from the inside out using low pressure dry compressed air, or carefully tap out dust.
- 7 Securely install the filter element into the canister.
- 8 Install the gasket and baffle (if equipped), and end cap onto the air cleaner canister.
Note: Be sure the dust discharge valve is facing down when installed.
- 9 Secure the end cap to the air cleaner canister with the retaining clamps.
- 10 **Kubota D905 models:** Swing the engine pivot plate back to its original position and make sure the engine pivot plate lock pin locks into place.

REV A

CHECKLIST A PROCEDURES

A-7 Perform Engine Maintenance - Kubota Models



Note: Engine specifications require that this one time procedure be performed after the first 50 hours of operation.

Required maintenance procedures and additional engine information is available in the *Kubota D905 Operator's Manual* (Kubota part number 16622-8916-5) OR the *Kubota DF752 Operator's Manual* (Kubota part number EG601-8916-1).

Kubota D905 Operator's Manual	
Genie part number	31743

Kubota DF752 Operator's Manual	
Genie part number	84250

A-8 Perform Engine Maintenance - Kubota Models



Note: Engine specifications require that this procedure be performed every 50 hours or weekly, whichever comes first.

Required maintenance procedures and additional engine information is available in the *Kubota D905 Operator's Manual* (Kubota part number 16622-8916-5) OR the *Kubota DF752 Operator's Manual* (Kubota part number EG601-8916-1).

Kubota D905 Operator's Manual	
Genie part number	31743

Kubota DF752 Operator's Manual	
Genie part number	84250

CHECKLIST A PROCEDURES

REV A

A-9 Perform Engine Maintenance - Kubota Models



Note: Engine specifications require that this procedure be performed every 100 hours.

Required maintenance procedures and additional engine information is available in the *Kubota D905 Operator's Manual* (Kubota part number 16622-8916-5) OR the *Kubota DF752 Operator's Manual* (Kubota part number EG601-8916-1).

Kubota D905 Operator's Manual	
Genie part number	31743
Kubota DF752 Operator's Manual	
Genie part number	84250

A-10 Grease the Turntable Rotation Bearing and Worm Drive Gear



Note: Genie specifications require that this procedure be performed every 100 hours.

Yearly application of lubrication to the turntable bearing and worm drive gear is essential to good machine performance and service life. Continued use of an improperly greased gear will result in component damage.

- 1 Raise the secondary boom and place a safety chock on the secondary boom lift cylinder. Carefully lower the boom onto the lift cylinder safety chock.

WARNING Crushing hazard. Keep hands away from the cylinder and all moving parts when lowering the secondary boom.

Note: The lift cylinder safety chock is available through Genie Service Parts (part number 36555).

- 2 Locate the grease fitting on the inside of the bearing in the middle of the turntable.
- 3 Pump grease into the turntable rotation bearing. Rotate the turntable in increments of 4 to 5 inches / 10 to 13 cm at a time and repeat this step until the entire bearing has been greased.
- 4 Remove the safety chock. Lower the boom to the stowed position.

REV A

CHECKLIST A PROCEDURES

- 5 Locate the grease fitting on the worm drive housing.

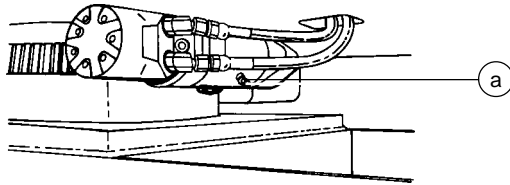

a grease fitting

- 6 Pump grease into the gear until you see it coming out of the side of the gear housing.
- 7 Grease each tooth on the outside of the turntable rotation bearing.

Grease Specification

Chevron Ultra-duty grease, EP NLGI 2 (lithium based) or equivalent

A-11
Perform Engine Maintenance -
Kubota Models



Note: Engine specifications require that this procedure be performed every 200 hours.

Required maintenance procedures and additional engine information is available in the *Kubota D905 Operator's Manual* (Kubota part number 16622-8916-5) OR the *Kubota DF752 Operator's Manual* (Kubota part number EG601-8916-1).

Kubota D905 Operator's Manual

Genie part number 31743

Kubota DF752 Operator's Manual

Genie part number 84250

CHECKLIST A PROCEDURES

REV A

A-12 Drain the Fuel Filter/ Water Separator - Diesel Models



Note: Genie specifications require that this procedure be performed every 200 hours or monthly, whichever comes first.

Proper maintenance of the fuel filter/water separator is essential for good engine performance. Failure to perform this procedure can lead to poor engine performance and component damage.

⚠ DANGER Explosion and fire hazard. Engine fuels are combustible. Perform this procedure in an open, well-ventilated area away from heaters, sparks, flames and lighted tobacco. Always have an approved fire extinguisher within easy reach.

Note: Perform this procedure with the engine off.

- 1 Locate the fuel filter/water separator and loosen the vent plug located on the fuel filter/water separator head.

- 2 Loosen the drain plug located at the bottom of the bowl. Allow the water to drain into a suitable container until fuel starts to come out. Immediately tighten the drain plug.

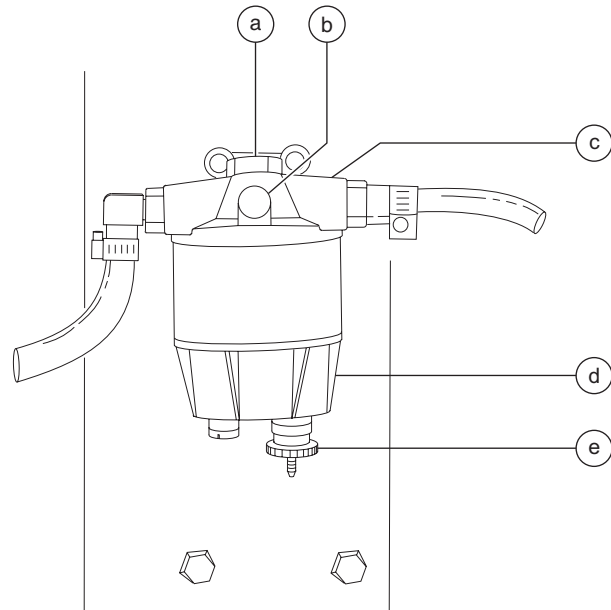

- | | |
|---|----------------|
| a | head bolt |
| b | vent plug |
| c | separator head |
| d | filter bowl |
| e | drain plug |

- 3 Tighten the vent plug and clean up any spills or wet surfaces.

Note: If the fuel bowl is completely drained, you must prime, or bleed, the fuel filter/water separator before starting the engine. See step 5.

- 4 Start the engine from the ground controls and check the fuel filter/water separator for leaks.

REV A

CHECKLIST A PROCEDURES

Bleed the fuel system:

Note: Before bleeding the system, fill the fuel tank.

- 5 Loosen the vent plug/screw located on the filter head.
- 6 Operate the hand primer until fuel, free of air, flows from the vent plug/screw. Tighten the vent plug/screw on the filter head.
- 7 Loosen the vent screw, located on top of the fuel injection pump.
- 8 Operate the hand primer until fuel, free of air, flows from the vent plug/screw. Tighten the vent plug/screw on the injection pump.
- 9 Clean up any fuel that may have spilled.
- 10 Attempt to start the engine using the starter motor for a maximum of 15 seconds, resting the starter for 30 seconds before trying again.
- 11 Inspect the fuel filter/water separator for leaks.

⚠ DANGER Explosion and fire hazard. If a fuel leak is discovered, keep any additional personnel from entering the area and do not operate the machine. Repair the leak immediately.

Note: Information to perform this procedure is also available in the *Kubota D905 Operator's Manual*, (Kubota part number 16622-8916-5) OR the *Perkins 403C-11 User's Handbook* (Perkins part number 100816460).

Kubota D905 Operator's Manual

Genie part number	31743
-------------------	-------

Perkins 403C-11 User's Handbook

Genie part number	97360
-------------------	-------

Checklist B Procedures

REV A

B-1

Check the Engine Choke - Gasoline/LPG Models



Note: Genie requires that this procedure be performed every 250 hours or quarterly, whichever comes first.

A properly functioning choke is essential to good engine performance. An improperly functioning choke will result in difficulty with engine starting.

Note: The manual choke is solenoid operated and is only operational in the gasoline mode. This choke will not operate in propane mode.

- 1 Check the choke linkage connections.

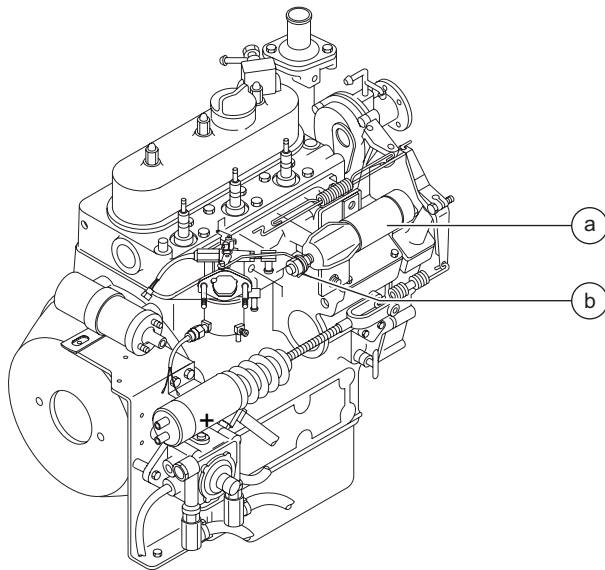

- a choke solenoid
b linkage lock nuts

- 2 Turn the key switch to ground control and then pull out the ground control red Emergency Stop button to the on position.
- 3 While operating the choke switch, inspect the choke solenoid.
 - ⊙ Result: The choke solenoid should be fully retracted when the choke switch is activated.
- 4 Turn the key switch to platform control.
- 5 Pull out the platform control red Emergency Stop button to the on position and then operate the choke switch and listen for choke solenoid operation.

REV A

CHECKLIST B PROCEDURES

B-2 Check the Exhaust System



Note: Genie requires that this procedure be performed every 250 hours or quarterly, whichever comes first.

Maintaining the exhaust system is essential to good engine performance and service life. Running the engine with a damaged or leaking exhaust system can cause component damage and unsafe operating conditions.

▲WARNING Bodily injury hazard. Do not inspect while the engine is running. Remove the key to secure from operation.

▲CAUTION Bodily injury hazard. Beware of hot engine components. Contact with hot engine components may cause severe burns.

- 1 Pull up on the pull pin on the engine pivot plate located under the pump. Swing the engine pivot plate away from the machine to access the exhaust system.
- 2 Be sure that all nuts and bolts are tight.
- 3 Inspect all welds for cracks.
- 4 Inspect for exhaust leaks; i.e., carbon buildup around seams and joints.

B-3 Inspect the Battery



Note: Genie requires that this procedure be performed every 250 hours or quarterly, whichever comes first.

Proper battery condition is essential to good machine performance and operational safety. Improper fluid levels or damaged cables and connections can result in component damage and hazardous conditions.

▲WARNING Electrocutation hazard. Contact with hot or live circuits could result in death or serious injury. Remove all rings, watches and other jewelry.

▲WARNING Bodily injury hazard. Batteries contain acid. Avoid spilling or contacting battery acid. Neutralize battery acid spills with baking soda and water.

- 1 Put on protective clothing and eye wear.
- 2 Be sure that the battery cable connections are free of corrosion.

Note: Adding terminal protectors and a corrosion preventative sealant will help eliminate corrosion on the battery terminals and cables.

- 3 Be sure that the battery retainer and cable connections are tight.
- 4 Fully charge the battery. Allow the battery to rest 24 hours before continuing this procedure to allow the battery cells to equalize.

CHECKLIST B PROCEDURES

REV A

- 5 Remove the battery vent caps and check the specific gravity of each battery cell with a hydrometer. Note the results.
- 6 Check the ambient air temperature and adjust the specific gravity reading for each cell as follows:
 - Add 0.004 to the reading of each cell for every 10° F / -12.2° C above 80° F / 26.7° C.
 - Subtract 0.004 from the reading of each cell for every 10° F / -12.2° C below 80° F / 26.7° C.
 - ⦿ Result: All battery cells display an adjusted specific gravity of 1.277 or higher. The battery is fully charged. Proceed to step 10.
 - ✗ Result: One or more battery cells display a specific gravity of 1.217 or below. Proceed to step 7.
- 7 Perform an equalizing charge OR fully charge the battery and allow the battery to rest at least 6 hours.
- 8 Remove the battery vent caps and check the specific gravity of each battery cell with a hydrometer. Note the results.
- 9 Check the ambient air temperature and adjust the specific gravity reading for each cell as follows:
 - Add 0.004 to the reading of each cell for every 10° F / -12.2° C above 80° F / 26.7° C.
 - Subtract 0.004 from the reading of each cell for every 10° F / -12.2° C below 80° F / 26.7° C.
 - ⦿ Result: All battery cells display a specific gravity of 1.277 or greater. The battery is fully charged. Proceed to step 10.
 - ✗ Result: The difference in specific gravity readings between cells is greater than 0.1 OR the specific gravity of one or more cells is less than 1.217. Replace the battery.
- 10 Check the battery acid level. If needed, replenish with distilled water to $\frac{1}{8}$ inch / 3 mm below the bottom of the battery fill tube. Do not overfill.
- 11 Install the vent caps and neutralize any electrolyte that may have spilled.

REV A

CHECKLIST B PROCEDURES

B-4 Inspect the Electrical Wiring



Note: Genie requires that this procedure be performed every 250 hours or quarterly, whichever comes first.

Maintaining electrical wiring in good condition is essential to safe operation and good machine performance. Failure to find and replace burnt, chafed, corroded or pinched wires could result in unsafe operating conditions and may cause component damage.

⚠ WARNING Electrocutation hazard. Contact with hot or live circuits may cause death or serious injury. Remove all rings, watches and other jewelry.

- 1 Inspect the following areas for burnt, chafed, corroded and loose wires:
 - Engine compartment electrical panel
 - Engine wiring harness
 - Inside of the ground control box
 - Turntable manifold wiring
- 2 Start the engine from the ground controls.
- 3 Raise the secondary boom until the mid-pivot is 10 feet / 3 m off the ground.
- 4 Inspect the turntable center area for burnt, chafed and pinched cables.
- 5 Lower the boom to the stowed position and turn the engine off.
- 6 Inspect the following areas for burnt, chafed, corroded, pinched and loose wires:
 - Cable track on the primary, jib and secondary booms
 - Jib boom to platform cable harness
 - Inside of the platform control box

B-5 Inspect the Tires, Wheels and Lug Nut Torque



Note: Genie requires that this procedure be performed every 250 hours or quarterly, whichever comes first.

Maintaining the tires and wheels, including proper wheel fastener torque, is essential to safe operation and good performance. Tire and/or wheel failure could result in a machine tip-over. Component damage may also result if problems are not discovered and repaired in a timely fashion.

⚠ WARNING Bodily injury hazard. An over-inflated tire can explode and could cause death or serious injury.

⚠ WARNING Tip-over hazard. Do not use temporary flat tire repair products.

Note: The tires on some machines are foam-filled and do not need air added to them.

- 1 Check all tire treads and sidewalls for cuts, cracks, punctures and unusual wear.
- 2 Check each wheel for damage, bends and cracked welds.
- 3 Check each lug nut for proper torque. Refer to Section 2, *Specifications*.
- 4 Check the pressure in each air-filled tire. Refer to Section 2, *Specifications*.

CHECKLIST B PROCEDURES

REV A

B-6 Confirm the Proper Brake Configuration



Note: Genie requires that this procedure be performed every 250 hours or quarterly, whichever comes first.

Proper brake configuration is essential to safe operation and good machine performance. Hydraulically-released, spring-applied individual wheel brakes can appear to operate normally when they are actually not fully operational.

- 1 Check each torque hub disconnect cap to be sure it is in the engaged position.

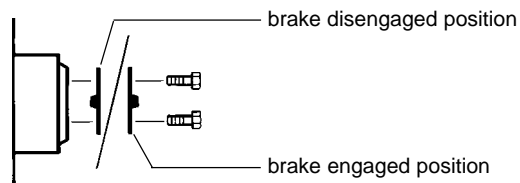

B-7 Check the Oil Level in the Drive Hubs



Note: Genie requires that this procedure be performed every 250 hours or quarterly, whichever comes first.

Failure to maintain proper drive hub oil levels may cause the machine to perform poorly and continued use may cause component damage.

- 1 Drive the machine to rotate the hub until the plugs are located one on top and the other at 90 degrees.

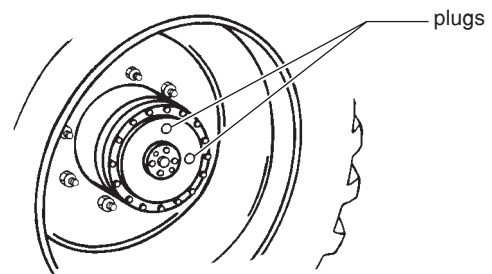

- 2 Remove the plug located at 90 degrees and check the oil level.
- ⊙ Result: The oil level should be even with the bottom of the plug hole.
- 3 If necessary, remove the top plug and add oil until the oil level is even with the bottom of the side plug hole.
- 4 Apply pipe thread sealant to the plugs, then install the plugs into the hub.
- 5 Check the torque of the drive hub mounting bolts. Refer to Section 2, *Specifications*.
- 6 Repeat this procedure for each drive hub.

REV A

CHECKLIST B PROCEDURES

**B-8
Perform Engine Maintenance -
Perkins 403C-11 Models**



Note: Engine specifications require that this procedure be performed every 250 hours or six months, whichever comes first.

Required maintenance procedures and additional engine information is available in the *Perkins 403C-11 User's Handbook* (Perkins part number 100816460).

Perkins 403C-11 User's Handbook	
Genie part number	97360

**B-9
Check and Adjust the
Engine RPM**



Note: Genie requires that this procedure be performed every 250 hours or quarterly, whichever comes first.

Maintaining the engine rpm at the proper setting for both low and high idle is essential to good engine performance and service life. The machine will not operate properly if the rpm is incorrect and continued use may cause component damage.

Gasoline/LPG Models:

NOTICE Perform this procedure in gasoline mode with the engine at normal operating temperature.

- 1 Connect an rpm gauge to the engine, then start the engine from the ground controls.

⊙ Result: Low idle should be 1600 rpm.

Skip to step 3 if the low idle rpm is correct.

CHECKLIST B PROCEDURES

REV A

- Turn the low idle adjustment screw on the carburetor clockwise to increase rpm or counterclockwise to decrease rpm.

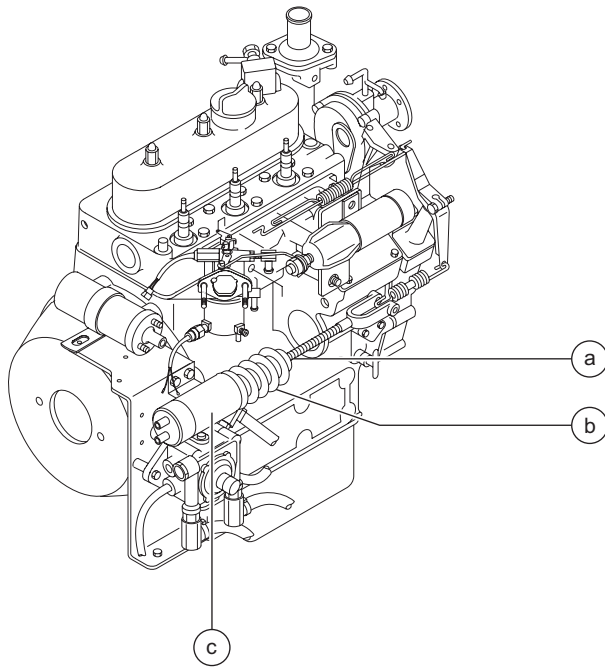

Gasoline/LPG idle adjustments
 a high idle adjustment nut and lock nut
 b solenoid boot
 c high idle solenoid

- Move the engine idle control switch to high idle (rabbit symbol) from the ground controls.

☉ Result: High idle should be 3000 rpm.

If high idle rpm is correct, disregard adjustment steps 4 through 6.

- Loosen the spring lock nut.
- Turn the high idle adjustment nut and spring lock nut clockwise to increase the rpm or counterclockwise to decrease the rpm.
- Tighten the spring lock nut. Then recheck the rpm.

Diesel models:

- Connect an rpm gauge to the engine, and then start the engine from the ground controls.

Kubota D905 models:

☉ Result: Low idle should be 1300 rpm.

Perkins 403C-11 models:

☉ Result: Low idle should be 1500 rpm.

Skip to step 3 if the low idle rpm is correct.

- Loosen the lock nut, then turn the low idle adjustment screw clockwise to increase the rpm or counterclockwise to decrease the rpm. Tighten the lock nut and recheck the rpm.

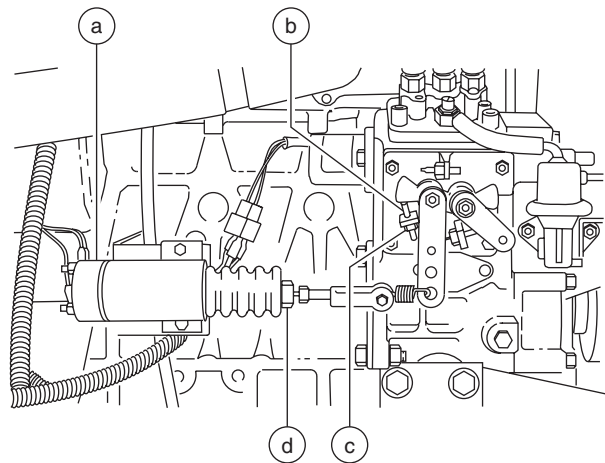

Kubota D905
 a rpm solenoid
 b low idle adjustment screw
 c lock nut
 d high idle adjustment nut

REV A

CHECKLIST B PROCEDURES

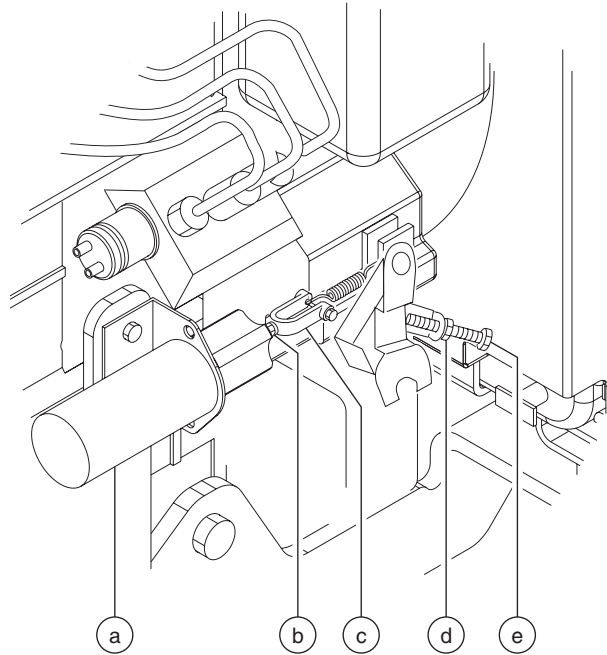

Perkins 403C-11
 a solenoid
 b yoke locknut
 c yoke
 d low idle lock nut
 e low idle adjustment screw

- 3 Move the engine idle control switch to high idle (rabbit symbol) from the ground controls.

⊙ Result: High idle should be 3000 rpm.

If high idle rpm is correct, disregard adjustment step 4.

- 4 Loosen the lock nut on the solenoid, then turn the solenoid boot counterclockwise to increase the rpm or clockwise to decrease the rpm. Tighten the lock nut and recheck the rpm.

B-10 Test the Ground Control Override



Note: Genie requires that this procedure be performed every 250 hours or quarterly, whichever comes first.

A properly functioning ground control override is essential to safe machine operation. The ground control override function is intended to allow ground personnel to operate the machine from the ground controls whether or not the red Emergency Stop button on the platform controls is in the on or off position. This function is particularly useful if the operator at the platform controls cannot return the boom to the stowed position.

- 1 Push in the platform red Emergency Stop button to the off position.
- 2 Turn the key switch to ground control and pull out the red Emergency Stop button to the on position.
- 3 Start the engine from the ground controls and operate each boom function through a partial cycle at the ground controls.

⊙ Result: All boom functions should operate.

CHECKLIST B PROCEDURES

REV A

B-11 Test the Platform Self-leveling

Note: Genie requires that this procedure be performed every 250 hours or quarterly, whichever comes first.

Automatic platform self-leveling throughout the full cycle of boom raising and lowering is essential for safe machine operation. The platform is maintained at level by the platform leveling slave cylinder which is controlled by the master cylinder located at the base of the primary boom. A platform self-leveling failure creates an unsafe working condition.

- 1 Turn the key switch to ground control and pull out the red Emergency Stop button to the on position.
 - 2 Lower the boom to the stowed position.
 - 3 Adjust the platform to a level position using the platform leveling switch.
 - 4 Raise and lower the primary boom through a full cycle.
- ⊙ Result: The platform should remain level at all times to within ± 5 degrees.

B-12 Test the Engine Idle Select



Note: Genie requires that this procedure be performed every 250 hours or quarterly, whichever comes first.

A properly operating engine idle select switch is essential to good engine performance and safe machine operation. There are three settings.

Low idle (turtle symbol) allows the operator to control individual boom functions and to drive the machine at a reduced speed.

High idle (rabbit symbol) allows the operator to control multiple boom and/or drive functions simultaneously. This setting maintains a consistent high idle.

Foot switch activated high idle (rabbit and foot switch symbols) should be used for normal machine operation. This selection activates high idle only when the foot switch is pressed down.

- 1 Pull out the red Emergency Stop button to the on position at both the ground and platform controls.
 - 2 Start the engine from the ground controls. Then move the engine idle control switch to high idle (rabbit symbol) and hold in the ON position.
- ⊙ Result: The engine should change to high idle.
- 3 Release the engine idle control switch.
- ⊙ Result: The engine should return to low idle.
- 4 Turn the key switch to platform controls.
 - 5 At the platform controls, move the engine idle control switch to high idle (rabbit symbol).
- ⊙ Result: The engine should change to high idle.

REV A

CHECKLIST B PROCEDURES

- 6 Move the engine idle control switch to low idle (turtle symbol).
- ⊙ Result: The engine should change to low idle.
- 7 Move the engine idle control switch to foot switch activated high idle (rabbit and foot switch symbol).
- ⊙ Result: The engine should not change to high idle.
- 8 Press down the foot switch.
- ⊙ Result: The engine should change to high idle.

B-13

Test the Fuel Select Operation - Gasoline/LPG Models



Note: Genie requires that this procedure be performed every 250 hours or quarterly, whichever comes first.

The ability to select and switch between gasoline and LPG fuels as needed is essential to safe machine operation. A fuel selection can be made when the engine is running or not. Switching malfunctions and/or the failure of the engine to start and run properly in both fuel modes and through all idle speeds can indicate fuel system problems that could develop into a hazardous situation.

Note: Perform this test after checking the gasoline and LPG fuel levels, and warming the engine to normal operating temperature.

- 1 Move the fuel select switch to gasoline and then move the engine idle control switch to foot switch activated high idle (rabbit and foot switch symbol).
- 2 Start the engine from the platform controls and allow it to run at low idle.
- 3 Press down the foot switch to allow the engine to run at high idle.
- ⊙ Result: The engine should start promptly and operate smoothly in low and high idle.

CHECKLIST B PROCEDURES

REV A

- 4 Release the foot switch and stop the engine.
 - 5 Move the fuel select switch to LPG.
 - 6 Restart the engine and allow it to run at low idle.
 - 7 Press down the foot switch to allow the engine to run at high idle.
- ⊙ Result: The engine should start promptly and operate smoothly in low and high idle.

Note: The engine may hesitate momentarily and then continue to run on the selected fuel if the fuel source is switched while the engine is running.

B-14 Test the Drive Brakes



Note: Genie requires that this procedure be performed every 250 hours or quarterly, whichever comes first.

Proper brake action is essential to safe machine operation. The drive brake function should operate smoothly, free of hesitation, jerking and unusual noise. Hydrostatic brakes and hydraulically-released individual wheel brakes can appear to operate normally when not fully operational.

⚠ WARNING Bodily injury hazard. Be sure that the machine is not in free-wheel or partial free-wheel configuration. See B-6, *Confirm the Proper Brake Configuration*.

Note: Select a test area that is firm, level and free of obstructions.

- 1 Mark a test line on the ground for reference.
- 2 Start the engine from the platform controls.
- 3 Select high range drive (machine on level surface symbol).
- 4 Move the engine idle control switch to foot switch activated high idle (rabbit and foot switch).
- 5 Lower the boom into the stowed position.

REV A

CHECKLIST B PROCEDURES

- 6 Choose a point on the machine; i.e., contact patch of a tire, as a visual reference for use when crossing the test line.
- 7 Bring the machine to top drive speed before reaching the test line. Release the drive joystick when your reference point on the machine crosses the test line.
- 8 Measure the distance between the test line and your machine reference point.

Note: The brakes must be able to hold the machine on any slope it is able to climb.

B-15

Test the Drive Speed - Stowed Position



Note: Genie requires that this procedure be performed every 250 hours or quarterly, whichever comes first.

Proper drive function movement is essential to safe machine operation. The drive function should respond quickly and smoothly to operator control. Drive performance should also be free of hesitation, jerking and unusual noise over the entire proportionally controlled speed range.

Note: Select a test area that is firm, level and free of obstructions.

- 1 Create start and finish lines by marking two lines on the ground 40 feet / 12.2 m apart.
- 2 Start the engine from the platform controls.
- 3 Select high range drive (machine on level surface symbol).
- 4 Move the engine idle control switch to foot switch activated high idle (rabbit and foot switch).
- 5 Lower the boom into the stowed position.
- 6 Choose a point on the machine; i.e., contact patch of a tire, as a visual reference for use when crossing the start and finish lines.
- 7 Bring the machine to top drive speed before reaching the start line. Begin timing when your reference point on the machine crosses the start line.
- 8 Continue at full speed and note the time when the machine reference point passes over the finish line.

CHECKLIST B PROCEDURES

REV A

B-16

Test the Drive Speed - Raised or Extended Position



Note: Genie requires that this procedure be performed every 250 hours or quarterly, whichever comes first.

Proper drive function movement is essential to safe machine operation. The drive function should respond quickly and smoothly to operator control. Drive performance should also be free of hesitation, jerking and unusual noise over the entire proportionally controlled speed range.

Note: Select a test area that is firm, level and free of obstructions.

- 1 Create start and finish lines by marking two lines on the ground 40 feet / 12.2 m apart.
- 2 Start the engine from the platform controls.
- 3 Move the engine idle select switch to foot switch activated high idle (rabbit and foot switch symbol).
- 4 Press down the foot switch and raise the primary boom above horizontal.
- 5 Choose a point on the machine; i.e., contact patch of a tire, as a visual reference for use when crossing the start and finish lines.
- 6 Bring the machine to top drive speed before reaching the start line. Begin timing when your reference point on the machine crosses the start line.
- 7 Continue at full speed and note the time when the machine reference point crosses the finish line.
- 8 Lower the boom to the stowed position and extend the boom 1 foot / 30 cm.
- 9 Choose a point on the machine; i.e., contact patch of a tire, as a visual reference for use when crossing the start and finish lines.
- 10 Bring the machine to top drive speed before reaching the start line. Begin timing when your reference point on the machine crosses the start line.
- 11 Continue at top speed and note the time when the machine reference point crosses the finish line.

REV A

CHECKLIST B PROCEDURES

B-17**Inspect the Fuel and Hydraulic Tank Cap Venting Systems**

Note: Genie requires that this procedure be performed every 250 hours or quarterly, whichever comes first. Perform this procedure more often if dusty conditions exist.

Free-breathing fuel and hydraulic tank caps are essential for good machine performance and service life. A dirty or clogged tank cap may cause the machine to perform poorly and continued use may cause component damage. Extremely dirty conditions may require that the caps be inspected more often.

⚠ DANGER Explosion and fire hazard. Engine fuels are combustible. Perform this procedure in an open, well-ventilated area away from heaters, sparks, flames and lighted tobacco. Always have an approved fire extinguisher within easy reach.

1 Remove the cap from the fuel tank.

2 Check for proper venting.

⊙ Result: Air passes through the fuel tank cap. Proceed to step 4.

⊗ Result: If air does not pass through the cap, clean or replace the cap. Proceed to step 3.

Note: When checking for positive tank cap venting, air should pass freely through the cap.

3 Using a mild solvent, carefully wash the cap venting system. Dry using low pressure compressed air. Repeat this procedure beginning with step 2.

4 Install the fuel tank cap onto the fuel tank.

5 Remove the breather cap from the hydraulic tank.

6 Check for proper venting.

⊙ Result: Air passes through the fuel tank cap. Proceed to step 8.

⊗ Result: If air does not pass through the cap, clean or replace the cap. Proceed to step 7.

Note: When checking for positive tank cap venting, air should pass freely through the cap.

7 Using a mild solvent, carefully wash the cap venting system. Dry using low pressure compressed air. Repeat this procedure beginning with step 6.

8 Install the breather cap onto the hydraulic tank.

CHECKLIST B PROCEDURES

REV A

B-18**Perform Hydraulic Oil Analysis**

Note: Genie requires that this procedure be performed every 250 hours or quarterly, whichever comes first.

Replacement or testing of the hydraulic oil is essential for good machine performance and service life. Dirty oil and a clogged suction strainer may cause the machine to perform poorly and continued use may cause component damage. Extremely dirty conditions may require oil changes to be performed more often.

Note: Before replacing the hydraulic oil, the oil may be tested by an oil distributor for specific levels of contamination to verify that changing the oil is necessary. **If the hydraulic oil is not replaced at the two year inspection, test the oil quarterly. Replace the oil when it fails the test.** See E-1, *Test or Replace the Hydraulic Oil*.

B-19**Test the Alarm Package (if equipped)**

Note: Genie requires that this procedure be performed every 250 hours or quarterly, whichever comes first.

The alarm package includes:

- Travel alarm
- Descent alarm
- Flashing beacon

Alarms and a beacon are installed to alert operators and ground personnel of machine proximity and motion. The alarm package is installed on the ground controls side turntable cover.

Note: The alarms and beacon will operate with the engine running or not running.

- 1 At the ground controls, pull out the red Emergency Stop button to the on position and turn the key switch to ground control.
 - ⦿ Result: The flashing beacon should be on and flashing.
- 2 Move the primary boom switch to the down position, hold for a moment and then release it. Move the secondary boom switch to the down position, hold for a moment and then release it.
 - ⦿ Result: The descent alarm should sound when each switch is held down.
- 3 Turn the key switch to platform control.

REV A

CHECKLIST B PROCEDURES

- 4 At the platform controls pull out the red Emergency Stop button to the on position.
- ⊙ Result: The flashing beacon should be on and flashing.
- 5 Press down the foot switch. Move the primary boom switch to the down position, hold for a moment and then release it. Move the secondary boom switch to the down position, hold for a moment and then release it.
- ⊙ Result: The descent alarm should sound when each control switch is held down.
- 6 Press down the foot switch. Move the drive control handle off center, hold for a moment and then release it. Move the drive control handle off center in the opposite direction, hold for a moment and then release it.
- ⊙ Result: The travel alarm should sound when the drive control handle is moved off center in either direction.

B-20**Replace the Diesel Fuel Filter/
Water Separator Element -
Diesel Models**

Note: Engine specifications require that this procedure be performed every 400 hours.

Replacing the diesel fuel filter is essential to good engine performance and service life. A dirty or clogged filter may cause the engine to perform poorly and continued use may cause component damage. Extremely dirty conditions may require that the filter be replaced more often.

⚠ DANGER

Explosion and fire hazard. Engine fuels are combustible. Replace the fuel filter in an open, well-ventilated area away from heater, sparks, flames and lighted tobacco. Always have an approved fire extinguisher within easy reach.

Note: Perform this procedure with the engine off.

- 1 Locate the fuel filter/water separator and loosen the vent plug located on the fuel filter/water separator head.

CHECKLIST B PROCEDURES

REV A

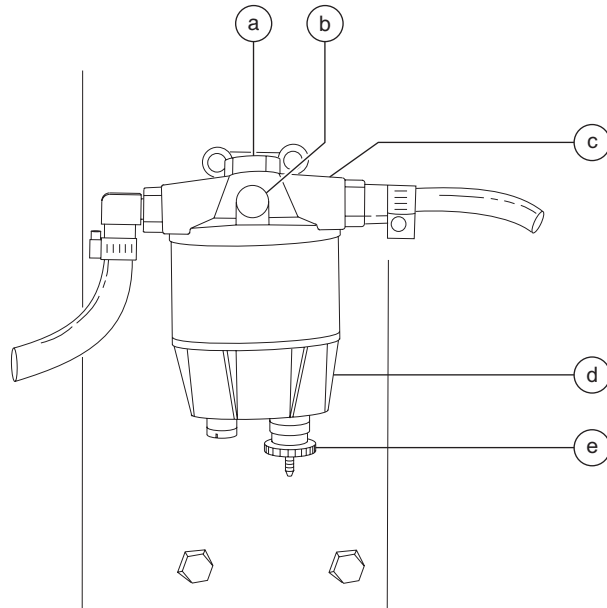

- a head bolt
- b vent plug
- c separator head
- d filter bowl
- e drain plug

- 2 Place a container under the filter bowl. Loosen the drain plug located at the bottom of the bowl. Completely drain the fuel.
- 3 Loosen the head bolt then rotate the filter bowl counterclockwise and remove it.
- 4 Remove the filter element from the bowl.
- 5 Apply a thin layer of oil to the bowl gasket and then install the new filter element onto the bowl.
- 6 Tighten the drain plug and fill the bowl and filter assembly with clean diesel fuel.
- 7 Install the filter and bowl assembly onto the filter head. Torque the head bolt to 65 in lbs / 7 Nm.
- 8 Tighten the vent plug.
- 9 Clean up any diesel fuel that may have spilled during the installation procedure.

Bleed the fuel system:

Note: Before bleeding the system, fill the fuel tank.

- 10 Loosen the vent plug/screw located on the filter head.
- 11 Operate the hand primer until fuel, free of air, flows from the vent plug/screw. Tighten the vent plug/screw on the filter head.
- 12 Loosen the vent screw, located on top of the fuel injection pump.
- 13 Operate the hand primer until fuel, free of air, flows from the vent plug/screw. Tighten the vent plug/screw on the injection pump.
- 14 Clean up any fuel that may have spilled.
- 15 Attempt to start the engine using the starter motor for a maximum of 15 seconds, resting the starter for 30 seconds before trying again.
- 16 Inspect the fuel filter/water separator for leaks.

⚠ DANGER

Explosion and fire hazard. If a fuel leak is discovered, keep any additional personnel from entering the area and do not operate the machine. Repair the leak immediately.

Note: Information to perform this procedure is also available in the *Kubota D905 Operator's Manual* (Kubota part number 16622-8916-5).

Kubota D905 Operator's Manual

Genie part number

31743

REV A

CHECKLIST B PROCEDURES

B-21

Perform Engine Maintenance - Kubota D905 Models



Note: Engine specifications require that this procedure be performed every 400 hours.

Required maintenance procedures and additional engine information is available in the *Kubota D905 Operator's Manual* (Kubota part number 16622-8916-5).

Kubota D905 Operator's Manual

Genie part number

31743

Checklist C Procedures

REV A

C-1 Grease the Platform Overload Mechanism (if equipped)



Note: Genie specifications require that this procedure be performed every 500 hours or 6 months, whichever comes first. Perform this procedure more often if dusty conditions exist.

Application of lubrication to the platform overload mechanism is essential to safe machine operation. Continued use of an improperly greased platform overload mechanism could result in the system not sensing an overloaded platform condition and will result in component damage.

- 1 Locate the grease fittings on each pivot pin of the platform overload assembly.
- 2 Thoroughly pump grease into each grease fitting using a multi-purpose grease.

Grease Specification

Chevron Ultra-duty grease, EP NLGI 2 (lithium based) or equivalent

C-2 Test the Platform Overload System (if equipped)



Note: Genie specifications require that this procedure be performed every 500 hours or six months, whichever comes first.

Testing the platform overload system regularly is essential to safe machine operation. Continued use of an improperly operating platform overload system could result in the system not sensing an overloaded platform condition. Machine stability could be compromised resulting in the machine tipping over.

The platform overload system is designed to detect an overloaded platform and prevent machine operation anytime the machine is turned on. When activated, the system halts all normal boom operation, giving visual and audible warning to the operator.

Models equipped with the platform overload option are provided with additional machine components: an adjustable spring-loaded platform support subassembly, a limit switch, an electronic module which receives the overload signal and interrupts power, and an audio/visual warning indication to alert the operator of the overload.

REV A

CHECKLIST C PROCEDURES

The platform support subassembly utilizes two load support arms that are opposed in a full parallelogram link. This isolates platform loads into a shear or vertical state, which translates into a compressive load. A spring in the parallelogram link supports this purely compressive load regardless of where the load is placed in the platform.

As weight is added to the platform, the spring will compress until, when the platform is overloaded, the lower arm contacts a limit switch and thereby activating the overload signal. When adjusted correctly, the platform overload system will deactivate normal boom operation at platform capacity.

Note: Perform this procedure with the machine on a firm, level surface.

- 1 Turn the key switch to platform control. Start the engine and level the platform.
- 2 Determine the maximum platform capacity. Refer to the machine serial plate.
- 3 Remove all weight, tools and accessories from the platform.

Note: Failure to remove all weight, tools and accessories from the platform will result in an inaccurate test.

- 4 Using a suitable lifting device, place a test weight equal to that of the available capacity one of the locations shown. Refer to Illustration 1.
 - ⊙ Result: The platform overload indicator lights should be off at both the ground and platform controls and the alarm should not sound.
 - ⊗ Result: The platform overload indicator lights are on and the alarm is sounding. Calibrate the platform overload system. Refer to Repair Procedure 2-3, *How to Calibrate the Platform Overload System (if equipped)*.
- 5 Carefully move the test weight to each remaining location. Refer to Illustration 1.
 - ⊙ Result: The platform overload indicator lights should be off at both the ground and platform controls and the alarm should not sound.
 - ⊗ Result: The platform overload indicator lights are on and the alarm is sounding. Calibrate the platform overload system. Refer to Repair Procedure 2-3, *How to Calibrate the Platform Overload System (if equipped)*.

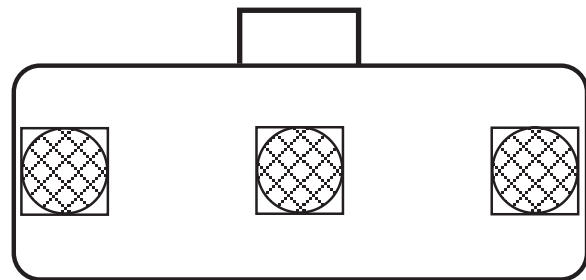

Illustration 1

CHECKLIST C PROCEDURES

REV A

- 6 Using a suitable lifting device, place an additional 10 lbs / 4.5 kg of weight onto the platform.
- ⊙ Result: The alarm should sound. The platform overload indicator lights should be flashing at both the ground and platform controls.
 - ⊗ Result: The alarm does not sound and the platform overload indicator lights are not flashing. Calibrate the platform overload system. Refer to Repair Procedure 2-3, *How to Calibrate the Platform Overload System (if equipped)*.

Note: There may be a 2 second delay before the overload indicator lights flash and the alarm sounds.

- 7 Carefully move the test weights to each remaining location on the platform. Refer to Illustration 1.
- ⊙ Result: The alarm should sound. The platform overload indicator lights should be flashing at both the ground and platform controls.
 - ⊗ Result: The alarm does not sound and the platform overload indicator lights are not flashing. Calibrate the platform overload system. Refer to Repair Procedure 2-3, *How to Calibrate the Platform Overload System (if equipped)*.

Note: There may be a 2 second delay before the overload indicator lights flash and the alarm sounds.

- 8 Test all machine functions from the platform controls.
- ⊙ Result: All platform control functions should not operate.
- 9 Turn the key switch to ground control.
- 10 Test all machine functions from the ground controls.
- ⊙ Result: All ground control functions should not operate.
- 11 Using auxiliary power, test all machine functions from the ground controls.
- ⊙ Result: All ground control functions should operate.
- 12 Using a suitable lifting device, lift the additional test weight from the platform.
- ⊙ Result: The platform overload indicator lights should turn off at both the ground and platform controls and the alarm should not sound.
- Note: There may be a 2 second delay before the overload indicator lights and alarm turn off.
- 13 Start the engine and test all machine functions from the ground controls.
- ⊙ Result: All ground control functions should operate normally.
- 14 Turn the key switch to platform control.
- 15 Test all machine functions from the platform controls.
- ⊙ Result: All platform control functions should operate.
- Note: If the platform overload system is not operating properly, Refer to Repair Procedure 2-3, *How to Calibrate the Platform Overload System (if equipped)*.
- 16 Using a suitable lifting device, remove the remaining test weights from the platform.

REV A

CHECKLIST C PROCEDURES

C-3 Clean the Fuel Tank - Diesel Models



Note: Genie requires that this procedure be performed every 500 hours or six months, whichever comes first.

Removing sediment from the fuel tank is essential to good engine performance and service life. A dirty fuel tank may cause the fuel filter to clog prematurely resulting in poor engine performance and possible component damage.

⚠ DANGER Explosion and fire hazard. Engine fuels are combustible. Clean the fuel tank in an open, well-ventilated area away from heater, sparks, flames and lighted tobacco. Always have an approved fire extinguisher within easy reach.

Note: Immediately clean up any fuel that may have spilled during this procedure.

- 1 **Models with fuel shutoff valve:** Turn the manual fuel shutoff valve, located next to the tank, to the closed position.

- 2 Using an approved hand-operated pump, drain the fuel tank into a suitable container. Refer to Section 2, *Specifications*, for tank capacity.

⚠ DANGER Explosion and fire hazard. When transferring fuel, connect a grounding wire between the machine and pump or container.

Note: Be sure to only use a hand operated pump suitable for use with gasoline and/or diesel fuel.

- 3 Tag, disconnect and plug the fuel supply and return hoses at the tank. Clean up any fuel that may have spilled.
- 4 Remove the tank retainer plate fasteners at the bulkhead. Remove the tank from the machine.

NOTICE Component damage hazard. The fuel tank is plastic and may become damaged if allowed to fall.

- 5 Rinse out the inside of the tank using a mild solvent.
- 6 Install the tank onto the machine. Install the tank retainer plate fasteners at the bulkhead.
- 7 Install the fuel supply and return hoses to the tank. Tighten the clamps.
- 8 **Models with fuel shutoff valve:** Turn the manual fuel shutoff valve, located next to the tank, to the open position.

CHECKLIST C PROCEDURES

REV A

C-4
Perform Engine Maintenance - Diesel Models



Note: Engine specifications require that this procedure be performed every 500 hours.

Required maintenance procedures and additional engine information is available in the *Kubota D905 Operator's Manual* (Kubota part number 16622-8916-5) OR the *Perkins 403C-11 User's Handbook* (Perkins part number 100816460).

Kubota D905 Operator's Manual	
Genie part number	31743

Perkins 403C-11 User's Handbook	
Genie part number	97360

C-5
Perform Engine Maintenance - Kubota D905 Models



Note: Engine specifications require that this procedure be performed every 800 hours.

Required maintenance procedures and additional engine information is available in the *Kubota D905 Operator's Manual* (Kubota part number 16622-8916-5).

Kubota D905 Operator's Manual	
Genie part number	31743

Checklist D Procedures

REV A

D-1 Check the Primary Boom Wear Pads



Note: Genie requires that this procedure be performed every 1000 hours or annually, whichever comes first.

Maintaining the primary boom wear pads in good condition is essential to safe machine operation. Wear pads are placed on boom tube surfaces to provide a low friction, replaceable wear pad between moving parts. Improperly shimmed wear pads or continued use of worn out wear pads may result in component damage and unsafe operating conditions.

- 1 Turn the key switch to ground control and pull out the red Emergency Stop button to the on position.
- 2 Extend the primary boom approximately 10 inches / 25 cm.
- 3 Measure each wear pad. Replace the wear pad if it is less than 0.41 inch / 1 cm thick. If the wear pad is more than 0.41 inch / 1 cm thick, shim as necessary to obtain zero clearance and zero drag.
- 4 Extend and retract the primary boom through the entire range of motion to check for tight spots that could cause binding or scraping.

Note: Always maintain squareness between the primary boom outer and inner tubes.

D-2 Check the Free-wheel Configuration



Note: Genie requires that this procedure be performed every 1000 hours or annually, whichever comes first.

Proper use of the free-wheel configuration is essential to safe machine operation. The free-wheel configuration is used primarily for towing. A machine configured to free-wheel without operator knowledge may cause death or serious injury and property damage.

WARNING Collision hazard. Select a work site that is firm and level.

- 1 Chock the steer wheels to prevent the machine from rolling.
- 2 Center a lifting jack of ample capacity (15000 lbs / 7000 kg) under the drive chassis between the non-steering wheels.
- 3 Lift the wheels off the ground and then place jack stands under the drive chassis for support.
- 4 Disengage the torque hubs by turning over the torque hub disconnect caps on each non-steering wheel hub.

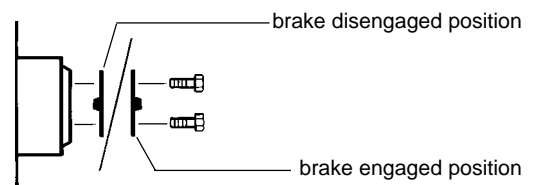

CHECKLIST D PROCEDURES

REV A

- 5 Manually rotate each non-steering wheel.
- ⊙ Result: Each non-steering wheel should rotate with minimum effort.
- 6 Re-engage the torque hubs by turning over the hub disconnect caps. Carefully remove the jack stands, lower the machine and remove the jack.

⚠ WARNING Collision hazard. Failure to re-engage the torque hubs may cause death or serious injury and property damage.

D-3**Replace the Drive Hub Oil**

Note: Genie requires that this procedure be performed every 1000 hours or annually, whichever comes first.

Replacing the torque hub oil is essential for good machine performance and service life. Failure to replace the torque hub oil at yearly intervals may cause the machine to perform poorly and continued use may cause component damage.

- 1 Select the drive torque hub to be serviced.
Drive the machine to rotate the hub until the plugs are located one on top and the other at 90 degrees.

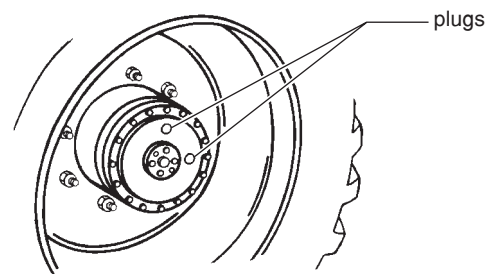

- 2 Remove both plugs and drain the oil.
- 3 Drive the machine until one plug is at the top and the other is at 90 degrees.
- 4 Fill the hub with oil from the top hole until the oil level is even with the bottom of the side hole. Refer to Section 2, *Specifications*.
- 5 Install the plugs into the drive hub.
- 6 Repeat this procedure for each torque hub.

REV A

CHECKLIST D PROCEDURES

D-4 Replace the Hydraulic Filters



Note: Genie requires that this procedure be performed every 1000 hours or annually, whichever comes first.

Replacement of the hydraulic filters are essential for good machine performance and service life. A dirty or clogged filter may cause the machine to perform poorly and continued use may cause component damage. Extremely dirty conditions may require that the filter be replaced more often.

Hydraulic return filter:

CAUTION Burn hazard. Beware of hot oil. Contact with hot oil may cause severe burns.

Note: The return hydraulic filter is mounted on the hydraulic tank.

- 1 Place a suitable container under the return filter.
- 2 Clean the area around the oil filter, then remove the filter with an oil filter wrench.
- 3 Apply a thin layer of oil to the new oil filter gasket.
- 4 Install the new filter and tighten it securely by hand. Clean up any oil that may have spilled.

Medium pressure filter:

CAUTION Burn hazard. Beware of hot oil. Contact with hot oil may cause severe burns.

Note: The medium pressure filter is mounted in the engine compartment.

- 5 Place a suitable container under the medium pressure filter.
- 6 Remove the filter housing by using a wrench on the nut provided on the bottom of the housing.
- 7 Remove the filter element from the housing.
- 8 Inspect the housing seal and replace it if necessary.
- 9 Install the new filter element into the housing and tighten securely.
- 10 Clean up any oil that may have spilled during the installation procedure.
- 11 Start the engine from the ground controls.
- 12 Activate any boom function and inspect the filters and related components to be sure that there are no leaks.
- 13 Use a permanent ink marker to write the date and number of hours from the hour meter on the filters.

CHECKLIST D PROCEDURES

REV A

D-5 Check the Turntable Rotation Bearing Bolts



Note: Genie requires that this procedure be performed every 1000 hours or annually, whichever comes first.

Maintaining proper torque on the turntable bearing bolts is essential to safe machine operation. Improper bolt torque could result in an unsafe operating condition and component damage.

- 1 Raise the secondary boom and place a safety chock on the secondary boom lift cylinder. Carefully lower the boom onto the lift cylinder safety chock. Turn the machine off.

WARNING Crushing hazard. Keep hands away from the cylinder and all moving parts when lowering the secondary boom.

Note: The lift cylinder safety chock is available through Genie Service Parts (Genie part number 36555).

- 2 Check to ensure that each turntable bearing bolt is torqued in specified order to 180 ft-lbs / 244 Nm.

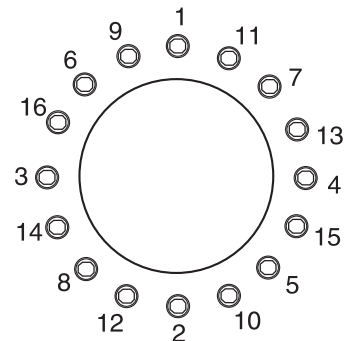

Bolt torque sequence

- 3 Remove the safety chock. Lower the boom to the stowed position.
- 4 Access the turntable bearing bolts through the access hole on the side of the chassis.
- 5 Check to ensure that each bearing mounting bolt under the drive chassis is torqued in specified order to 180 ft-lbs / 244 Nm.

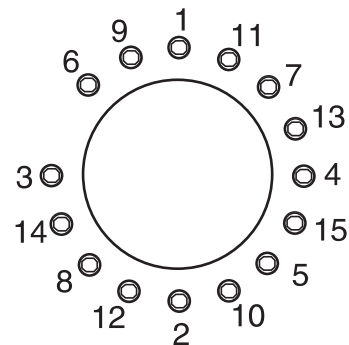

Bolt torque sequence

REV A

CHECKLIST D PROCEDURES

D-6 Inspect for Turntable Bearing Wear



Note: Genie requires that this procedure be performed every 1000 hours or annually, whichever comes first.

Periodic inspection of turntable bearing wear is essential to safe machine operation, good machine performance and service life. Continued use of a worn turntable bearing could create an unsafe operating condition, resulting in death or serious injury and component damage.

- 1 Grease the turntable bearing. See A-10, *Grease the Turntable Bearing and Rotate Gear*.
- 2 Torque the turntable bearing bolts to specification. See D-5, *Check the Turntable Rotation Bearing Bolts*.
- 3 Raise the primary and secondary booms to full height using the ground controls. Do not extend the primary boom.

- 4 Place a dial indicator between the drive chassis and the turntable at a point that is directly under, or in line with, the boom and no more than 1 inch / 2.5 cm from the bearing.

Note: To obtain an accurate measurement, place the dial indicator no more than 1 inch / 2.5 cm from the turntable rotation bearing.

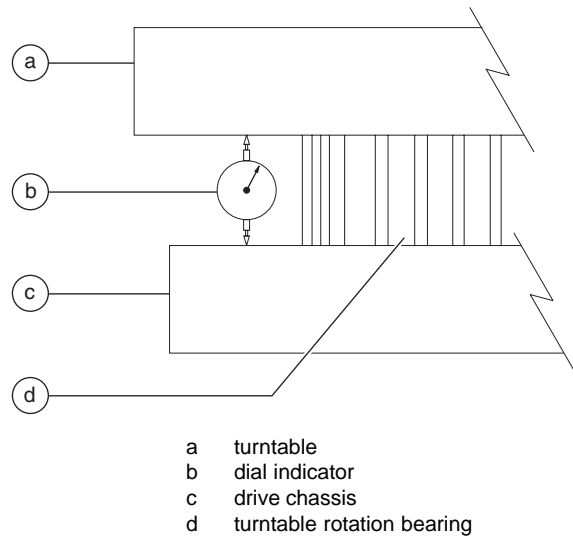

- 5 Adjust the dial indicator to "0".
 - 6 Lower the secondary boom to the stowed position and lower the primary boom to a horizontal position. Fully extend the primary boom.
 - 7 Note the reading on the dial indicator.
- ⊙ Result: The measurement is less than 0.055 inch / 1.4 mm. The bearing is good.
- ⊗ Result: The measurement is more than 0.055 inch / 1.4 mm. The bearing is worn and needs to be replaced.

CHECKLIST D PROCEDURES

REV A

- 8 Fully retract the primary boom. Raise the primary and secondary booms to full height. Visually inspect the dial indicator to be sure the needle returns to the "0" position.
- 9 Remove the dial indicator and rotate the turntable 90°.
- 10 Repeat steps 4 through 9 until the rotation bearing has been checked in at least four equally spaced areas 90° apart.
- 11 Lower the primary and secondary booms to the stowed position and turn the machine off.
- 12 Remove the dial indicator from the machine.

D-7 Perform Engine Maintenance



Note: Engine specifications requires that this procedure be performed every 1000 hours or annually, whichever comes first.

Required maintenance procedures and additional engine information is available in the *Kubota D905 Operator's Manual* (Kubota part number 16622-8916-5) OR the *Kubota DF752 Operator's Manual* (Kubota part number EG601-8916-1) OR the *Perkins 403C-11 User's Handbook* (Perkins part number 100816460).

Kubota D905 Operator's Manual	
Genie part number	31743
Kubota DF752 Operator's Manual	
Genie part number	84250
Perkins 403C-11 User's Handbook	
Genie part number	97360

Checklist E Procedures

REV A

E-1 Test or Replace the Hydraulic Oil



Note: Genie requires that this procedure be performed every 2000 hours or two years, whichever comes first.

Replacement or testing of the hydraulic oil is essential for good machine performance and service life. Dirty oil and suction strainers may cause the machine to perform poorly and continued use may cause component damage. Extremely dirty conditions may require oil changes to be performed more often.

Note: The machine uses Dexron equivalent hydraulic oil. Before replacing the hydraulic oil, the oil may be tested by an oil distributor for specific levels of contamination to verify that changing the oil is necessary. **If the hydraulic oil is not replaced at the two year inspection, test the oil quarterly. Replace the oil when it fails the test.**

Note: Perform this procedure with the boom in the stowed position.

- 1 Place a suitable container under the hydraulic tank. Refer to Section 2, *Specifications*.

- 2 **Before serial number 3364:** Close the two hydraulic tank shut-off valves at the hydraulic tank.

NOTICE

Component damage hazard. The engine must not be started with the hydraulic tank shut-off valves in the closed position or component damage will occur. If the tank valves are closed, remove the key from the key switch and tag the machine to inform personnel of the condition.

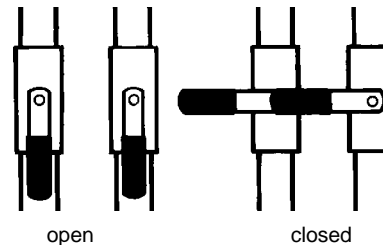

- 3 Remove the drain plug from the hydraulic tank and completely drain the tank into a container of suitable capacity. Refer to Section 2, *Specifications*.

CAUTION

Bodily injury hazard. Beware of hot oil. Contact with hot oil may cause severe burns.

- 4 Tag, disconnect and plug the hoses from the return filter. Cap the fittings on the return filter.
- 5 Tag, disconnect and plug the suction hoses from the bottom of the tank. Cap the fittings.
- 6 Remove the fasteners from the hydraulic tank hold down straps. Remove the straps.
- 7 Remove the turntable cover using a suitable lifting device.

WARNING

Crushing hazard. The turntable cover could become unbalanced and fall if not properly supported when removed from the machine.

CHECKLIST E PROCEDURES

REV A

- 8 Support and secure the hydraulic tank to a suitable lifting device. Remove the hydraulic tank from the machine.
- 9 Remove the suction strainers and clean them using a mild solvent.
- 10 Rinse out the inside of the tank using a mild solvent.
- 11 Install the suction strainers using a pipe thread sealant on the threads.
- 12 Install the drain plug into the tank using a pipe thread sealant on the threads.
- 13 Install the hydraulic tank on to the machine. Install the hydraulic tank hold down straps and tighten the retaining fasteners.
- 14 Fill the tank with hydraulic oil until the fluid until the fluid is within the top 2 inches / 5.1 cm of the sight gauge. Do not overfill.
- 15 **Before serial number 3364:** Open the two hydraulic tank shut-off valves at the hydraulic tank.

NOTICE Component damage hazard. The engine must not be started with the hydraulic tank shut-off valves in the closed position or component damage will occur. If the tank valves are closed, remove the key from the key switch and tag the machine to inform personnel of the condition.

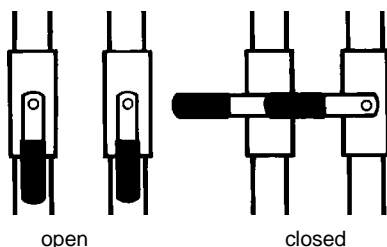

- 16 Clean up any oil that may have spilled. Properly discard of oil.
- 17 Start the engine and check for leaks.

E-2 Grease the Steer Axle Wheel Bearings, 2WD Models



Note: Genie requires that this procedure be performed every 2000 hours or every two years, whichever comes first.

Maintaining the steer axle wheel bearings is essential for safe machine operation and service life. Operating the machine with loose or worn wheel bearings may cause an unsafe operating condition and continued use may result in component damage. Extremely wet or dirty conditions or regular steam cleaning and pressure washing of the machine may require that this procedure be performed more often.

- 1 Loosen the wheel lug nuts. Do not remove them.
- 2 Block the non-steer wheels and center a lifting jack of ample capacity under the steer axle.
- 3 Raise the machine 6 inches / 15 cm and place blocks under the drive chassis for support.

CAUTION Crushing damage. The machine may fall if not properly supported.

- 4 Remove the lug nuts. Remove the tire and wheel assembly.
 - 5 Check for wheel bearing wear by attempting to move the wheel hub side to side, then up and down.
- ⊙ Result: There should be no side to side or up and down movement.

Skip to step 10 if there is no movement.

REV A

CHECKLIST E PROCEDURES

6 Remove the dust cap from the hub. Remove the cotter pin from the castle nut.

7 Tighten the castle nut to 158 ft-lbs / 214 Nm to seat the bearings.

Note: Rotate the hub by hand while torquing the castle nut to make sure the bearings seat properly.

8 Loosen the castle nut one full turn and then torque to 35 ft-lbs / 47 Nm.

9 Check for wheel bearing wear by attempting to move the wheel hub side to side, then up and down.

⊕ Result: If there is no side to side or up and down movement, continue with step 10 to grease the wheel bearings.

⊗ Result: If there is side to side or up and down movement, continue to step 10 and replace the wheel bearings with new ones.

Note: When replacing a wheel bearing, both the inner and outer bearings, including the pressed-in races, must be replaced.

10 Remove the castle nut.

11 Pull the hub off of the spindle. The washer and outer bearing should fall loose from the hub.

12 Place the hub on a flat surface and gently pry the bearing seal out of the hub. Remove the rear bearing.

13 Pack both bearings with clean, fresh grease.

14 Place the large inner bearing into the rear of the hub.

15 Install a new bearing grease seal into the hub by pressing it evenly into the hub until it is flush.

Note: Always replace the bearing grease seal when removing the hub.

16 Slide the hub onto the yoke spindle.

NOTICE Component damage hazard. Do not apply excessive force or damage to the lip of the seal may occur.

17 Fill the hub cavity with clean, fresh grease.

18 Place the outer bearing into the hub.

19 Install the washer and castle nut.

20 Tighten the castle nut to 158 ft-lbs / 214 Nm to seat the bearings.

Note: Rotate the hub by hand while torquing the castle nut to make sure the bearings seat properly.

21 Loosen the castle nut one full turn and then torque to 35 ft-lbs / 47 Nm.

22 Install a new cotter pin. Bend the cotter pin to lock it in.

Note: Always use a new cotter pin when installing a castle nut.

23 Install the dust cap, then the tire and wheel assembly. Torque the wheel lug nuts to specification. Refer to Section 2, *Specifications*.

CHECKLIST E PROCEDURES

REV A

E-3 Perform Engine Maintenance



Note: Engine specifications requires that this procedure be performed every 2000 hours or every two years, whichever comes first.

Required maintenance procedures and additional engine information is available in the *Kubota D905 Operator's Manual* (Kubota part number 16622-8916-5) OR the *Kubota DF752 Operator's Manual* (Kubota part number EG601-8916-1) OR the *Perkins 403C-11 User's Handbook* (Perkins part number 100816460).

Kubota D905 Operator's Manual	
Genie part number	31743

Kubota DF752 Operator's Manual	
Genie part number	84250

Perkins 403C-11 User's Handbook	
Genie part number	97360

E-4 Perform Engine Maintenance - Perkins 403C-11 Models



Note: Engine specifications require that this procedure be performed every 3000 hours.

Required maintenance procedures and additional engine information is available in the *Perkins 403C-11 User's Handbook* (Perkins part number 100816460).

Perkins 403C-11 User's Handbook	
Genie part number	97360

Repair Procedures



Observe and Obey:

- ☑ Repair procedures shall be completed by a person trained and qualified on the repair of this machine.
- ☑ Immediately tag and remove from service a damaged or malfunctioning machine.
- ☑ Repair any machine damage or malfunction before operating the machine.

Before Repairs Start:

- ☑ Read, understand and obey the safety rules and operating instructions in the appropriate *Genie Z-34/22 IC Operator's Manual* on your machine.
- ☑ Be sure that all necessary tools and parts are available and ready for use.
- ☑ Use only Genie approved replacement parts.
- ☑ Read each procedure completely and adhere to the instructions. Attempting shortcuts may produce hazardous conditions.
- ☑ Unless otherwise specified, perform each repair procedure with the machine in the following configuration:
 - Machine parked on a firm, level surface
 - Boom in the stowed position
 - Turntable rotated with the boom between the non-steer wheels
 - Key switch in the off position with the key removed
 - Wheels chocked
 - All external AC power disconnected from the machine

About This Section

Most of the procedures in this section should only be performed by a trained service professional in a suitably equipped workshop. Select the appropriate repair procedure after troubleshooting the problem.

Perform disassembly procedures to the point where repairs can be completed. To re-assemble, perform the disassembly steps in reverse order.

Symbols Legend



Safety alert symbol—used to alert personnel to potential personal injury hazards. Obey all safety messages that follow this symbol to avoid possible injury or death.

▲ DANGER

Indicates an imminently hazardous situation which, if not avoided, will result in death or serious injury.

▲ WARNING

Indicates a potentially hazardous situation which, if not avoided, could result in death or serious injury.

▲ CAUTION

Indicates a potentially hazardous situation which, if not avoided, may cause minor or moderate injury.

NOTICE

Indicates a potentially hazardous situation which, if not avoided, may result in property damage.

- ⊙ Indicates that a specific result is expected after performing a series of steps.
- ⊗ Indicates that an incorrect result has occurred after performing a series of steps.

Platform Controls

REV A

1-1 Drive Joystick

How to Adjust the Drive Joystick

Note: Perform this procedure with the engine off.

- 1 Remove the fasteners from the platform control box lid.
- 2 Open the control box lid and locate the drive joystick.

WARNING Electrocutation hazard. Contact with electrically charged circuits could result in death or serious injury. Remove all rings, watches and other jewelry.

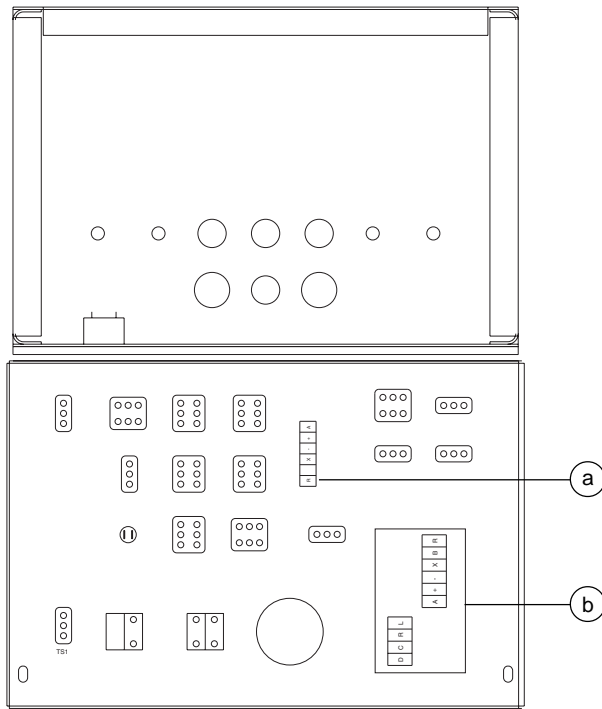

- a boom function speed controller
- b drive joystick

- 3 Locate and disconnect the wire connected to terminal "A" on the drive joystick circuit board.
- 4 Set a multimeter to read DC current.

Note: The multimeter, when set to read DC current, should be capable of reading up to 1200 mA.

- 5 Connect the black(-) lead from the multimeter to the wire that was just disconnected. Connect the red(+) lead of the multimeter to terminal "A" on the joystick.

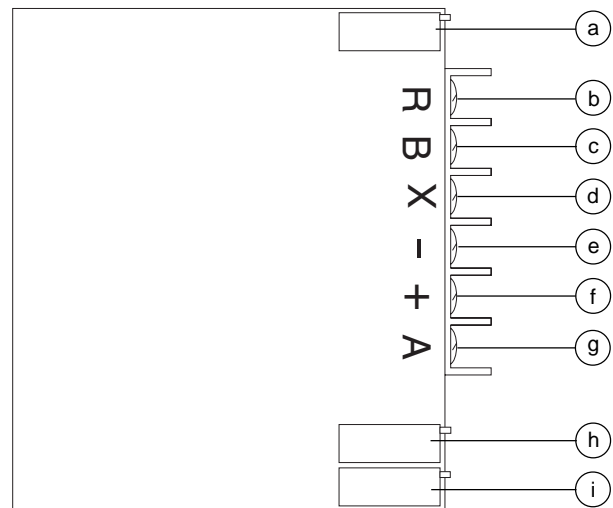

- a low range potentiometer
- b terminal "R", activates low range
- c terminal "B", drive reverse
- d terminal "X", brake release
- e terminal "-", ground
- f terminal "+", positive
- g terminal "A", drive forward
- h threshold potentiometer
- i high range potentiometer

- 6 Turn the keyswitch to platform controls and pull out the red Emergency Stop button out to the on position at both the ground and platform controls. Do not start the engine.

REV A

PLATFORM CONTROLS

Set the threshold:

Note: The drive joystick adjustments are not final adjustments. Final adjustments will need to be made to meet drive speed specifications. Refer to Section 2, *Specifications*.

- 7 Press down the foot switch. Move the drive joystick off center in either direction just until a current reading appears on the multimeter display.
- 8 Hold the drive joystick in position and adjust the THRESHOLD potentiometer until the multimeter displays approximately 600 mA.

Set the high range:

- 9 Press down the foot switch. Move and hold the drive joystick full stroke in either direction.
- 10 Hold the drive joystick in position and adjust the HI RANGE potentiometer until the multimeter displays slightly higher than 1100 mA.

Set the low range:

- 11 Start the engine from the platform controls and raise the primary boom approximately 3 feet / 1 m. Turn the engine off.
- 12 Press down the foot switch. Move and hold the drive joystick full stroke in either direction.
- 13 Hold the drive joystick in position and adjust the LO RANGE potentiometer until the multimeter displays approximately 700 mA.
- 14 Push in the red Emergency Stop button to the off position at the platform controls.
- 15 Disconnect the multimeter.
- 16 Connect the wire that was disconnected in step 3 to terminal "A" of the drive joystick.

Set the stowed drive speed:

Note: Select a test area that is firm, level and free of obstructions.

- 17 Pull out the red Emergency Stop button out to the on position at both the ground and platform controls.
- 18 Create start and finish lines by marking two lines on the ground 40 feet / 12.2 m apart.
- 19 Start the engine from the platform controls and move the engine idle select switch to foot switch activated high idle (rabbit and foot switch symbol).
- 20 Choose a point on the machine; i.e., contact patch of a tire, as a visual reference for use when crossing the start and finish lines.

PLATFORM CONTROLS

REV A

- 21 Bring the machine to top drive speed before reaching the start line. Begin timing when your reference point on the machine crosses the start line.
- 22 Continue at full speed and note the time when the machine reference point passes over the finish line. Refer to Section 2, *Specifications*.
- ⊙ Result: The stowed drive speed does not meet specification. Adjust the HI RANGE potentiometer on the drive joystick clockwise to increase the speed or counterclockwise to decrease the stowed drive speed. Continue to perform steps 20 through 22 until the stowed drive speed meets specification.
- 26 Continue at full speed and note the time when the machine reference point passes over the finish line. Refer to Section 2, *Specifications*.
- ⊙ Result: The raised drive speed does not meet specification. Adjust the LO RANGE potentiometer on the drive joystick clockwise to increase the speed or counterclockwise to decrease the raised drive speed. Continue to perform steps 24 through 26 until the raised drive speed meets specification.
- 27 Lower the primary boom to the stowed position. Turn the engine off.
- 28 Close the platform control box lid and install the fasteners.

Set the raised drive speed:

Note: Select a test area that is firm, level and free of obstructions.

- 23 Press down the foot switch and raise the primary boom approximately 3 feet / 1 m.
- 24 Choose a point on the machine; i.e., contact patch of a tire, as a visual reference for use when crossing the start and finish lines.
- 25 Bring the machine to top drive speed before reaching the start line. Begin timing when your reference point on the machine crosses the start line.

REV A

PLATFORM CONTROLS

1-2 Boom Function Speed Controller

Boom Function Speed Controller Adjustments

WARNING Electrocutation hazard. Contact with electrically charged circuits could result in death or serious injury. Remove all rings, watches and other jewelry.

Note: Do not adjust the controllers unless the static battery supply voltage is above 12V DC.

- 1 Turn the key switch to platform control and pull out the red Emergency Stop button to the on position at both the ground and platform controls.
- 2 Open the platform control box lid and locate the boom function speed controller.

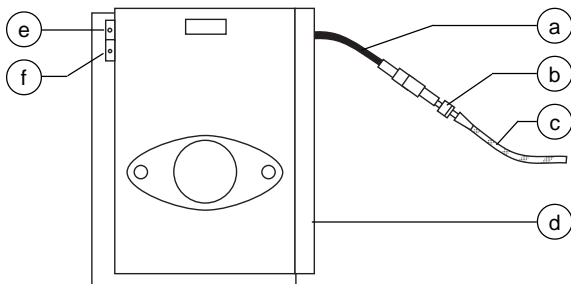

- a black wire
- b diode
- c white/red wire
- d boom function speed controller
- e max-out adjustable trimpot
- f threshold adjustable trimpot

- 3 Locate the diode between the black wire from the boom function speed controller and the white/red wire.
- 4 Connect the red (+) lead from a volt meter to the wire connector of the white/red wire next to the diode. Connect the black (-) lead to ground.
- 5 Turn the boom function speed controller to the CREEP position.
- 6 **Set the threshold:** Press down the foot switch. Move the primary boom toggle switch in the up direction until the voltage reading appears. Adjust the voltage to 5.5 to 6V DC. Turn the threshold trimpot adjustment screw clockwise to increase the voltage or counterclockwise to decrease the voltage.
- 7 Turn the boom function speed controller to the 9 position.
- 8 **Set the max-out:** Press down the foot switch. Move the primary boom toggle switch in the up direction. Adjust the voltage to 8.5 to 9V DC. Turn the max-out trimpot adjustment screw clockwise to increase the voltage or counterclockwise to decrease the voltage.

Boom function speed controller specifications

Threshold	5 to 6V DC
Max-out	8.5 to 9V DC

Platform Components

REV A

2-1 Platform Leveling Slave Cylinder

The slave cylinder and the rotator pivot are the two primary supports for the platform. The slave cylinder keeps the platform level through the entire range of primary boom motion. It operates in a closed-circuit hydraulic loop with the master cylinder. The slave cylinder is equipped with counterbalance valves to prevent movement in the event of a hydraulic line failure.

How to Remove the Platform Leveling Slave Cylinder

Note: When removing a hose assembly or fitting, the O-ring (if equipped) on the fitting and/or the hose end must be replaced. All connections must be torqued to specification during installation. Refer to Section 2, *Hydraulic Hose and Fitting Torque Specifications*.

Note: Before cylinder removal is considered, bleed the slave cylinder to be sure there is no air in the closed loop.

- 1 Extend the boom until the slave cylinder barrel-end pivot pin is accessible.
- 2 Raise the boom slightly and place blocks under the platform for support. Lower the boom until the platform is resting on the blocks.
- 3 Remove the pin retainer fastener from the rod-end pivot pin.
- 4 Remove the external snap ring from the barrel-end pivot pin.

- 5 Use a soft metal drift to remove the rod-end pivot pin.
- 6 Use a soft metal drift to remove the barrel-end pivot pin.
- 7 Carefully pull the cylinder out of the boom.
- 8 Tag and disconnect the hydraulic hoses from the slave cylinder and connect them together with a connector. Cap the fittings on the cylinder.

WARNING Bodily injury hazard. Spraying hydraulic oil can penetrate and burn skin. Loosen hydraulic connections very slowly to allow the oil pressure to dissipate gradually. Do not allow oil to squirt or spray.

How to Bleed the Slave Cylinder

- 1 Raise the jib boom to a horizontal position.
- 2 Activate the platform level toggle switch up and down through two platform leveling cycles to remove any air that might be in the system.

REV A

PLATFORM COMPONENTS

2-2 Platform Rotator

The platform rotator is a hydraulically-activated helical gear assembly used to rotate the platform 160 degrees.

How to Remove the Platform Rotator

Note: When removing a hose assembly or fitting, the O-ring (if equipped) on the fitting and/or the hose end must be replaced. All connections must be torqued to specification during installation. Refer to Section 2, *Hydraulic Hose and Fitting Torque Specifications*.

- 1 Remove the platform.
- 2 Tag, disconnect and plug the hydraulic hoses from the platform rotator manifold. Cap the fittings on the manifold.

WARNING Bodily injury hazard. Spraying hydraulic oil can penetrate and burn skin. Loosen hydraulic connections very slowly to allow the oil pressure to dissipate gradually. Do not allow oil to squirt or spray.

- 3 Support the platform mounting weldment with a suitable lifting device. Do not apply any lifting pressure.
- 4 Remove the six mounting bolts from the platform mounting weldment. Remove the center bolt and slide the platform mounting weldment off of the platform rotator.

- 5 Support the platform rotator with a suitable lifting device. Do not apply any lifting pressure.
- 6 Remove the pin retaining fasteners from the jib boom and leveling links to platform rotator pivot pins. Do not remove the pins.
- 7 Use a soft metal drift to remove the leveling link pivot pin. Lower the leveling links to the ground.
- 8 Support the jib boom and jib boom lift cylinder with an overhead crane.
- 9 Use a soft metal drift to drive both pins out and remove the platform rotator from the machine.

WARNING Crushing hazard. The jib boom and jib boom lift cylinder could fall when when the platform rotator is removed if not properly supported by the overhead crane.

PLATFORM COMPONENTS

REV A

How to Bleed the Platform Rotator

- 1 Connect a clear hose to the top bleed screw. Place the other end of the hose in a container to collect any discharge.

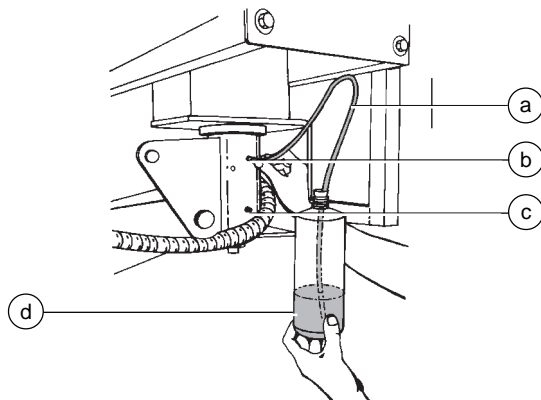

- a clear hose
- b top bleed valve
- c bottom bleed valve
- d container

- 2 Open the top bleed screw, but do not remove it.
- 3 Turn the key switch to ground control and pull out the red Emergency Stop button to the on position.
- 4 Hold the platform rotate toggle switch in the right direction for approximately 5 seconds, then release it. Repeat three times.

CAUTION Crushing hazard. Keep hands clear of the platform pivot weldment during rotation.

- 5 Hold the platform rotate toggle switch in the left direction for approximately 5 seconds, then release it.
- 6 Fully rotate the platform to the left and continue holding the platform rotate toggle switch until air stops coming out of the bleed screw. Immediately release the platform rotate toggle switch and close the bleed screw.
- 7 Rotate the platform to the right until it is centered.
- 8 Connect the clear hose to the bottom bleed screw. Open the bottom bleed screw, but do not remove it.
- 9 Rotate the platform to the right and continue holding the platform rotate switch until air stops coming out of the bleed screw.

CAUTION Crushing hazard. Keep hands clear of the platform pivot weldment during rotation.

- 10 Close the bleed screw and remove the hose.
- 11 Turn the key switch to the off position and clean up any hydraulic oil that may have spilled.
- 12 Turn the key switch to ground control and pull out the red Emergency Stop button to the on position.
- 13 Rotate the platform full left and right and inspect the bleed screws for leaks.

REV A

PLATFORM COMPONENTS

2-3 Platform Overload System

How to Calibrate the Platform Overload System (if equipped)

Calibration of the platform overload system is essential to safe machine operation. Continued use of an improperly calibrated platform overload system could result in the system failing to sense an overloaded platform. The stability of the machine is compromised and it could tip over.

- 1 Level the platform.
- 2 Determine the maximum platform capacity. Refer to the machine serial plate.
- 3 Using a suitable lifting device, place an appropriate test weight equal to that of the maximum platform capacity at the center of the platform floor.

Determine the limit switch trigger point:

- 4 Gently move the platform up and down by hand, so it bounces approximately 1 to 2 inches / 2.5 to 5 cm. Allow the platform to settle.

- ⊙ Result: **The overload indicator light and the alarm is on.** Slowly tighten the load spring adjustment nut by turning it clockwise just until the overload indicator light and alarm turns off.

Note: The platform will need to be moved up and down and allowed to settle between adjustments.

Note: There may be an approximate 2 second delay before the overload indicator light turns on and the alarm sounds.

- ⊙ Result: **The overload indicator light and alarm is off.** Slowly loosen the load spring adjustment nut by turning it counterclockwise just until the overload indicator light and alarm turn on.

Note: There may be an approximate 2 second delay before the overload indicator light turns on and the alarm sounds.

Note: The platform will need to be moved up and down and allowed to settle between adjustments.

PLATFORM COMPONENTS

REV A

Confirm the setting:

- 5 Turn the key switch to platform control.
- 6 Lift the test weight off the platform floor using a suitable lifting device.
- 7 Place the test weight back onto the center of the platform floor using a suitable lifting device.
- ⦿ Result: The alarm should be off. The platform overload indicator light should be off at both the ground and platform controls.

Note: There may be an approximate 2 second delay before the overload indicator light and alarm turn off.

- 8 Add an additional 10 lb / 4.5 kg test weight to the original test weight to overload the platform.
- ⦿ Result: The alarm should sound. The platform overload indicator light should be flashing at both the ground and platform controls.

Note: There may be an approximate 2 second delay before the overload indicator light turns on and the alarm sounds.

- 9 Test all machine functions from the platform controls.
- ⦿ Result: All platform control functions should not operate.
- 10 Turn the key switch to ground control.
- 11 Test all machine functions from the ground controls.
- ⦿ Result: All ground control functions should not operate.

Note: If the platform overload system is not operating properly, repeat steps 1 through 4.

Jib Boom Components

REV A

3-1 Jib Boom

How to Remove the Jib Boom

Note: Perform this procedure with the boom in the stowed position.

Note: When removing a hose assembly or fitting, the O-ring on the fitting and/or hose end must be replaced and then torqued to specification during installation. Refer to Section 2, *Hydraulic Hose and Fitting Torque Specifications*.

- 1 Remove the platform.
- 2 Remove the platform mounting weldment and the platform rotator. See 2-2, *How to Remove the Platform Rotator*.
- 3 Tag, disconnect and plug the jib boom lift cylinder hydraulic hoses. Cap the fittings on the jib boom lift cylinder.

▲WARNING Bodily injury hazard. Spraying hydraulic oil can penetrate and burn skin. Loosen hydraulic connections very slowly to allow the oil pressure to dissipate gradually. Do not allow oil to squirt or spray.

- 4 Remove the cable cover from the side of the jib boom.

- 5 Tag, disconnect and plug the hydraulic hoses from ports "T" and "P" of the jib boom manifold. Cap the fittings on the manifold.

▲WARNING Bodily injury hazard. Spraying hydraulic oil can penetrate and burn skin. Loosen hydraulic connections very slowly to allow the oil pressure to dissipate gradually. Do not allow oil to squirt or spray.

- 6 Tag and disconnect the electrical wiring from the jib boom manifold.
- 7 Attach a lifting strap from an overhead crane to the jib boom.
- 8 Remove the pin retaining fasteners from the jib boom pivot pin at the jib boom bellcrank.
- 9 Use a soft metal drift to remove the jib boom pivot pin. Remove the jib boom from the jib boom bellcrank.

▲WARNING Crushing hazard. The jib boom could fall when the pin is removed if not properly supported by the overhead crane.

- 10 Remove the pin retaining fasteners from the jib boom lift cylinder rod-end pivot pin. Do not remove the pin.
- 11 Remove both of the jib boom leveling links from the bellcrank.
- 12 Attach a lifting strap from an overhead crane to the rod-end of the jib boom lift cylinder.
- 13 Use a soft metal drift to remove the jib boom lift cylinder rod-end pivot pin. Remove the jib boom lift cylinder from the jib boom bellcrank.

▲WARNING Crushing hazard. The jib boom lift cylinder could fall when the pin is removed if not properly supported by the overhead crane.

JIB BOOM COMPONENTS

REV A

3-2 Jib Boom Bell Crank

How to Remove the Jib Boom Bell Crank

Note: Perform this procedure with the boom in the stowed position.

Note: When removing a hose assembly or fitting, the O-ring on the fitting and/or hose end must be replaced and then torqued to specification during installation. Refer to Section 2, *Hydraulic Hose and Fitting Torque Specifications*.

- 1 Remove the platform.
- 2 Remove the Jib Boom, See 3-1, *How to Remove the Jib Boom*.
- 3 Support and secure the jib boom bell crank to an appropriate lifting device.
- 4 Remove the pin retaining fasteners from the slave cylinder rod-end pivot pin. Do not remove the pin.
- 5 Remove the pin retaining fasteners from the jib boom bell crank at the extension boom. Use a soft metal drift to remove the pin.
- 6 Use a soft metal drift to remove the slave cylinder rod-end pivot pin.
- 7 Remove the jib boom bell crank from the extension boom.

AWARNING Crushing hazard. The jib boom bell crank could become unbalanced and fall when the pins are removed if not properly supported and secured to the lifting device.

3-3 Jib Boom Lift Cylinder

How to Remove the Jib Boom Lift Cylinder

Note: Perform this procedure with the boom in the stowed position.

Note: When removing a hose assembly or fitting, the O-ring on the fitting and/or hose end must be replaced and then torqued to specification during installation. Refer to Section 2, *Hydraulic Hose and Fitting Torque Specifications*.

- 1 Raise the jib boom slightly and place blocks under the platform mounting weldment. Lower the jib boom until the platform is resting on the blocks.

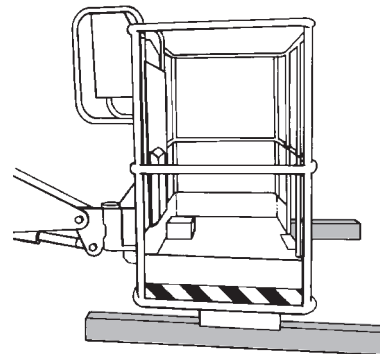

REV A

JIB BOOM COMPONENTS

- 2 Tag, disconnect and plug the jib boom lift cylinder hydraulic hoses. Cap the fittings on the jib boom lift cylinder.

▲WARNING Bodily injury hazard. Spraying hydraulic oil can penetrate and burn skin. Loosen hydraulic connections very slowly to allow the oil pressure to dissipate gradually. Do not allow oil to squirt or spray.

- 3 Remove the pin retaining fasteners from the jib boom lift cylinder rod-end pivot pin. Do not remove the pin.
- 4 Use a soft metal drift to tap the rod-end pivot pin half way out and lower one of the leveling links to the ground. Tap the pin the other direction and lower the opposite leveling link. Do not remove the pin.
- 5 Attach a lifting strap from an overhead crane to the rod end of the jib boom lift cylinder.
- 6 Remove the pin retaining fasteners from the jib boom lift cylinder barrel-end pivot pin. Use a soft metal drift to remove the barrel-end pivot pin.

▲WARNING Crushing hazard. The jib boom and/or platform could fall when the pin is removed if not properly supported.

- 7 Use a soft metal drift to remove the jib boom lift cylinder rod-end pivot pin. Remove the jib boom lift cylinder from the machine.

▲WARNING Crushing hazard. The jib boom lift cylinder could fall when the pins are removed if not properly supported by the overhead crane.

Primary Boom Components

REV A

4-1 Plastic Cable Track

The primary boom cable track guides the cables and hoses running up the boom. It can be repaired link by link without removing the cables and hoses that run through it. Removing the entire primary boom cable track is only necessary when performing major repairs that involve removing the primary boom.

How to Repair the Plastic Cable Track

NOTICE Component damage hazard. The primary boom cable track can be damaged if it is twisted.

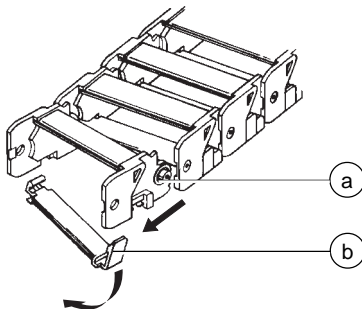

a link separation point
b lower clip

- 1 Use a slotted screwdriver to pry down on the lower clip.
- 2 Repeat step 1 for each link.
- 3 To remove a single link, open the lower clip and then use a screw driver to pry the link to the side.

4-2 Primary Boom

How to Shim the Primary Boom

Note: Measure each wear pad. Replace the pad if it is less than 0.41 inch / 1 cm thick. If the pad is more than 0.41 inch / 1 cm thick, perform the following procedure.

- 1 Extend the boom until the wear pads are accessible.
- 2 Loosen the wear pad mounting fasteners.
- 3 Install the new shims under the wear pad to obtain zero clearance and zero drag.
- 4 Tighten the mounting fasteners.
- 5 Extend and retract the boom through an entire cycle. Check for tight spots that could cause scraping or binding.

Note: Always maintain squareness between the outer and inner boom tubes.

REV A

PRIMARY BOOM COMPONENTS

How to Remove the Primary Boom

▲WARNING Bodily injury hazard. This procedure requires specific repair skills, lifting equipment and a suitable workshop. Attempting this procedure without these skills and tools could result in death or serious injury and significant component damage. Dealer service is strongly recommended.

Note: When removing a hose assembly or fitting, the O-ring on the fitting and/or hose end must be replaced and then torqued to specification during installation. Refer to Section 2, *Hydraulic Hose and Fitting Torque Specifications*.

Note: Perform this procedure with the boom in the stowed position.

- 1 Remove the platform.
- 2 Remove the platform rotator. See 2-2, *How to Remove the Platform Rotator*.
- 3 Remove the jib boom. See 3-1, *How to Remove the Jib Boom*.
- 4 Remove the jib boom bell crank. See 3-2, *How to Remove the Jib Boom Bell Crank*.
- 5 Support the slave cylinder.

- 6 Tag and disconnect the hydraulic hoses to the slave cylinder and connect them together using a connector. Plug the slave cylinder hoses from the cable track.

▲WARNING Bodily injury hazard. Spraying hydraulic oil can penetrate and burn skin. Loosen hydraulic connections very slowly to allow the oil pressure to dissipate gradually. Do not allow oil to squirt or spray.

- 7 Remove the external snap ring from the slave cylinder barrel-end pivot pin.
- 8 Use a soft metal drift to remove the slave cylinder barrel-end pin.
- 9 Remove the slave cylinder from the primary boom.
- 10 Support the cable track with an overhead crane or similar lifting device.
- 11 Remove the cable track mounting fasteners, then remove the cable track from the boom and lay it off to the side.

NOTICE Component damage hazard. The boom cable track can be damaged if it is twisted.

- 12 Remove the turntable end cover.
- 13 Remove the pin retaining fasteners from the master cylinder rod-end pivot pin. Use a soft metal drift to remove the pin. Pull the cylinder back and secure it from moving.
- 14 Remove the drive speed limit switch mounted on the side of the boom at the pivot end. Do not disconnect the wiring.

PRIMARY BOOM COMPONENTS

REV A

15 Tag, disconnect and plug the extension cylinder hydraulic hoses. Cap the fittings on the cylinder.

▲WARNING Bodily injury hazard. Spraying hydraulic oil can penetrate and burn skin. Loosen hydraulic connections very slowly to allow the oil pressure to dissipate gradually. Do not allow oil to squirt or spray.

16 Attach an overhead 5 ton / 5,000 kg crane to the center point of the boom.

17 Attach a similar lifting device to the primary boom lift cylinder.

18 Using the overhead crane, raise the primary boom to a horizontal position.

19 Place support blocks across the secondary boom to support the boom lift cylinder.

20 Remove the pin retaining fasteners from the primary boom lift cylinder rod-end pin. Use a soft metal drift to remove the pin.

▲CAUTION Crushing hazard. The boom lift cylinder will fall unless it is properly supported.

21 Lower the rod-end of the primary boom lift cylinder onto support blocks. Protect the cylinder rod from damage.

22 Remove the hose clamp brackets from the underside of the primary boom.

23 Remove the hose clamp from the side of the primary boom.

24 Remove the limit switch cam mounting fastener (if equipped).

Note: Note the position of the cam before removing it.

25 Remove the pin retaining fasteners from the primary boom pivot pin.

26 Use a soft metal drift to remove the primary boom pivot pin. Carefully remove the boom from the machine and place it on a structure capable of supporting it.

▲WARNING Crushing hazard. If the overhead crane is not properly attached, the boom could become unbalanced and fall when it is removed from the machine.

Note: During removal, the overhead crane strap will need to be carefully adjusted for proper balancing.

REV A

PRIMARY BOOM COMPONENTS

How to Disassemble the Primary Boom

Note: Complete disassembly of the boom is only necessary if the outer or inner boom tubes must be replaced. The extension cylinder can be removed without completely disassembling the boom.

See 4-4, *How to Remove the Extension Cylinder*.

- 1 Remove the boom. See 4-2, *How to Remove the Primary Boom*.
- 2 Place blocks under the extension cylinder for support.
- 3 Remove the retaining fasteners from the extension cylinder barrel-end pivot pin. Use a soft metal drift to remove the pin.
- 4 Label the location of all wear pads from the outer boom tube at the platform end. Remove all wear pads, including shims, from the platform end of the boom.

Note: Pay careful attention to the location and amount of shims used with each wear pad.

- 5 Carefully rotate the barrel end of the extension cylinder until the pin mounting bore is in a vertical position.
- 6 Attach a lifting strap from an overhead crane to the extension tube at the platform end.

- 7 Support and slide the extension tube out of the outer primary boom tube. Place the extension boom tube on blocks for support.

WARNING Crushing hazard. The boom tubes could become unbalanced and fall if not properly supported by the overhead crane.

Note: During removal, the overhead crane strap will need to be carefully adjusted for proper balancing.

- 8 Remove the external snap rings from the extension cylinder rod-end pivot pins at the platform end of the extension tube. Use a soft metal drift to remove the pins.
- 9 Support and slide the extension cylinder out of the base end of the extension tube. Place the extension cylinder on blocks for support.

Note: During removal, the overhead crane strap will need to be carefully adjusted for proper balancing.

- 10 Remove and label the wear pads from the extension cylinder.

Note: Pay careful attention to the location of each wear pad.

PRIMARY BOOM COMPONENTS

REV A

4-3 Primary Boom Lift Cylinder

The lift cylinder raises and lowers the primary boom. The lift cylinder is equipped with counterbalance valves to prevent movement in the event of a hydraulic line failure.

How to Remove the Primary Boom Lift Cylinder

⚠WARNING Bodily injury hazard. This procedure requires specific repair skills, lifting equipment and a suitable workshop. Attempting this procedure without these skills and tools could result in death or serious injury and significant component damage. Dealer service is strongly recommended.

Note: When removing a hose assembly or fitting, the O-ring on the fitting and/or hose end must be replaced and then torqued to specification during installation. Refer to Section 2, *Hydraulic Hose and Fitting Torque Specifications*.

- 1 Raise the primary boom enough to access the primary boom lift cylinder rod-end pivot pin.
 - 2 Raise the secondary boom enough to access the primary boom lift cylinder barrel-end pivot pin.
 - 3 Attach a lifting strap from an overhead crane to the primary boom for support. Do not apply any lifting pressure.
 - 4 Place a block of wood across the upper secondary boom to support the cylinder when the rod-end pivot pin is removed.
 - 5 Attach a lifting strap from a second overhead crane or other similar lifting device to the primary boom lift cylinder.
 - 6 Remove the rear turntable cover.
 - 7 Place a 4x4 inch / 10 x 10 cm block between the lower compression arms and the cross member of the upper secondary boom. Carefully lower the secondary boom onto the block.
- ⚠WARNING** Crushing hazard. Keep hands away from the block and all moving parts when lowering the secondary boom.
- 8 Remove the pin retaining fasteners from the primary boom lift cylinder rod-end pivot pin. Use a soft metal drift to remove the pin.
- ⚠WARNING** Crushing hazard. The primary boom could fall when the primary boom lift cylinder rod-end pivot pin is removed if not properly supported by the overhead crane.
- 9 Lower the rod end of the cylinder onto the blocks that were placed on the upper secondary boom.
 - 10 Remove the pin retaining fasteners from the upper compression arm pivot pin (same side of machine as the primary boom lift cylinder barrel-end pivot pin retaining fasteners).

REV A

PRIMARY BOOM COMPONENTS

- 11 Place a rod through the compression arm pivot pin and twist to remove the pin.
- 12 Swing the compression arm up out of the way and secure it from moving.
- 13 Tag, disconnect and plug the primary boom lift cylinder hydraulic hoses. Cap the fittings on the cylinder.

AWARNING Bodily injury hazard. Spraying hydraulic oil can penetrate and burn skin. Loosen hydraulic connections very slowly to allow the oil pressure to dissipate gradually. Do not allow oil to squirt or spray.

- 14 Support the primary boom lift cylinder with straps or ropes to restrict it from swinging freely when the barrel-end pivot pin is removed.
- 15 Remove the pin retaining fasteners from the lift cylinder barrel-end pivot pin. Do not remove the pivot pin.
- 16 Use the overhead crane to raise the primary boom 1 inch / 2.5 cm. This will relieve pressure on the barrel-end pivot pin.
- 17 Place a rod through the barrel-end pivot pin and twist to remove the pin.

CAUTION Crushing hazard. The primary boom lift cylinder may fall when the barrel-end pivot pin is removed if not properly supported by the overhead crane.

- 18 Attach a lifting strap from an overhead crane or similar lifting device to the rod end of the primary boom lift cylinder. Carefully loosen the straps and allow the barrel end of the primary boom lift cylinder to slowly swing down.
- 19 Carefully remove the cylinder from the machine.

4-4 Extension Cylinder

The extension cylinder extends and retracts the primary boom extension tube. The extension cylinder is equipped with counterbalance valves to prevent movement in the event of a hydraulic line failure.

How to Remove the Extension Cylinder

AWARNING Bodily injury hazard. This procedure requires specific repair skills, lifting equipment and a suitable workshop. Attempting this procedure without these skills and tools could result in death or serious injury and significant component damage. Dealer service is strongly recommended.

Note: When removing a hose assembly or fitting, the O-ring on the fitting and/or hose end must be replaced and then torqued to specification during installation. Refer to Section 2, *Hydraulic Hose and Fitting Torque Specifications*.

- 1 Raise the primary boom to a horizontal position. Then extend the boom approximately 3 to 4 feet / 1 m until the extension cylinder rod-end pivot pins are accessible.
- 2 Remove the external snap rings from the extension cylinder rod-end pivot pins. Use a soft metal drift to remove the pins.

PRIMARY BOOM COMPONENTS

REV A

- 3 Remove the rear turntable cover.
- 4 Raise the secondary boom until the master cylinder rod-end pivot pin is accessible.
- 5 Remove the drive speed limit switch from the pivot end of the primary boom. Do not disconnect the wiring.
- 6 Remove the pin retaining fasteners from the master cylinder rod end pivot pin. Use a soft metal drift to remove the pin.
- 7 Manually retract the master cylinder and push it toward the platform end of the boom to obtain enough clearance for the extension cylinder removal.
- 8 Tag, disconnect and plug the extension cylinder hydraulic hoses. Cap the fittings on the cylinder.

▲WARNING Bodily injury hazard. Spraying hydraulic oil can penetrate and burn skin. Loosen hydraulic connections very slowly to allow the oil pressure to dissipate gradually. Do not allow oil to squirt or spray.

- 9 Remove the pin retaining fasteners from the extension cylinder pivot pin. Use a soft metal drift to remove the pin.

- 10 Carefully pull out and properly support the extension cylinder from the primary boom using a lifting strap from an overhead crane.

▲CAUTION Crushing hazard. The cylinder may become unbalanced and fall if not properly supported by the overhead crane when removed from the extension tube.

Note: During removal, the overhead crane strap will need to be carefully adjusted for proper balancing.

Note: To make installation of the extension cylinder easier, be sure that the cylinder rod is extended 3 to 4 feet /1 m.

REV A

PRIMARY BOOM COMPONENTS

4-5 Platform Leveling Master Cylinder

The master cylinder acts as a pump for the slave cylinder. It is part of the closed circuit hydraulic loop that keeps the platform level through the entire range of primary boom motion. The master cylinder is located inside the upper mid-pivot at the pivot end of the primary boom.

How to Remove the Platform Leveling Master Cylinder

⚠WARNING Bodily injury hazard. This procedure requires specific repair skills, lifting equipment and a suitable workshop. Attempting this procedure without these skills and tools could result in death or serious injury and significant component damage. Dealer service is strongly recommended.

Note: Before cylinder removal is considered, bleed the cylinder to be sure that there is no air in the closed loop. See 2-1, *How to Bleed the Slave Cylinder*.

Note: When removing a hose assembly or fitting, the O-ring on the fitting and/or hose end must be replaced and then torqued to specification during installation. Refer to Section 2, *Hydraulic Hose and Fitting Torque Specifications*.

1 Remove the rear turntable cover.

- 2 Raise the secondary boom until the master cylinder barrel-end pivot pin is above the turntable counterweights.
- 3 Raise the primary boom until the master cylinder rod-end pivot pin is accessible.
- 4 Attach a lifting strap from an overhead crane to the upper pivot for support. Do not apply any lifting pressure.
- 5 Secure the upper secondary boom to the pivot end of the primary boom with a strap.

Note: Securing the upper secondary boom to the pivot will prevent the upper secondary boom from falling when the master cylinder barrel-end pivot pin is removed from the cylinder.

- 6 Tag, disconnect and plug the master cylinder hydraulic hoses. Cap the fittings on the cylinder.

⚠WARNING Bodily injury hazard. Spraying hydraulic oil can penetrate and burn skin. Loosen hydraulic connections very slowly to allow the oil pressure to dissipate gradually. Do not allow oil to squirt or spray.

- 7 Tie a strap around the lug on the rod end of the master cylinder and secure the strap to the primary boom.

Note: The strap will be used to lower the cylinder out of the upper pivot.

- 8 Remove the pin retaining fasteners from the master cylinder rod-end pivot pin. Use a soft metal drift to remove the pin.

PRIMARY BOOM COMPONENTS

REV A

- 9 Remove the pin retaining fasteners from the master cylinder barrel-end pivot pin.
- 10 Use a soft metal drift to remove the pin from the cylinder. Do not remove the pin from the upper mid-pivot. Push the pin to one side, only far enough to remove the cylinder.

▲ CAUTION Crushing hazard. The upper secondary boom and the upper pivot may fall if the pivot pin is completely removed.

Note: The pin should remain in one side of the upper secondary boom and upper mid-pivot.

- 11 Use the strap around the rod-end lug to lower the cylinder out of the machine.

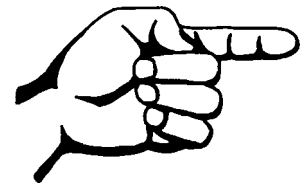

This page intentionally left blank.

Secondary Boom Components

REV A

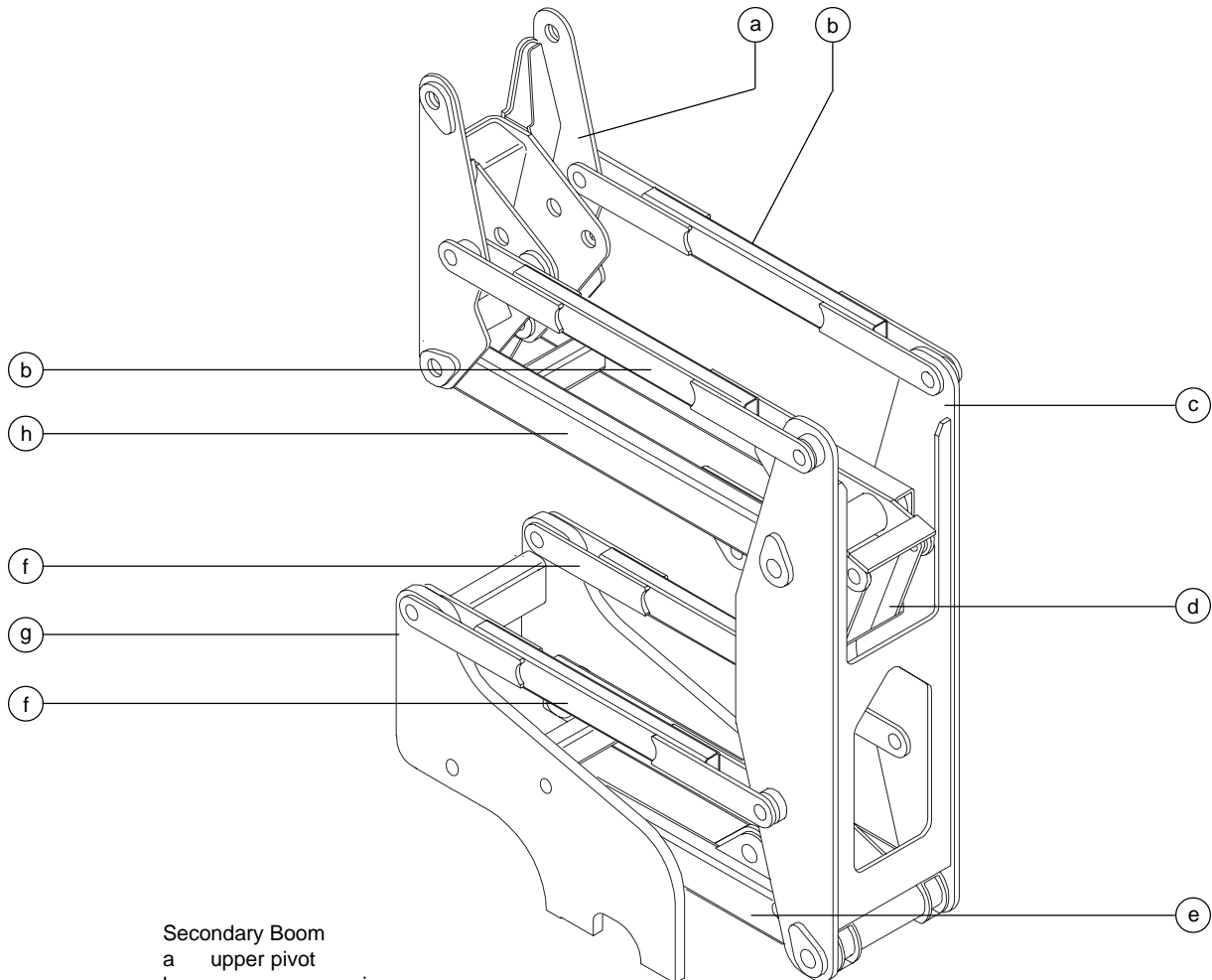

- Secondary Boom
 a upper pivot
 b upper compression arm
 c mid-pivot
 d compression link
 e lower secondary boom
 f lower compression arm
 g turntable pivot
 h upper secondary boom

REV A

SECONDARY BOOM COMPONENTS

5-1 Secondary Boom

How to Disassemble the Secondary Boom

⚠WARNING Bodily injury hazard. The procedures in this section require specific repair skills, lifting equipment and a suitable workshop. Attempting this procedure without these skills and tools could result in death or serious injury and significant component damage. Dealer service is required.

Note: When removing a hose assembly or fitting, the O-ring on the fitting and/or hose end must be replaced and then torqued to specification during installation. Refer to Section 2, *Hydraulic Hose and Fitting Torque Specifications*.

- 1 Remove the rear turntable cover.
- 2 Place a suitable lifting device under the platform for support.
- 3 Disconnect the battery.
- 4 Remove the cable cover from the side of the jib boom.
- 5 Remove the wire loom from the cables at the platform control box.

- 6 Locate the cables from the primary boom cable track to the platform control box. Number each cable and its entry location at the platform control box.
- 7 Open the platform control box.
- 8 Tag and disconnect each wire from the cables in the platform control box.

⚠WARNING Electrocutation hazard. Contact with electrically charged circuits could result in death or serious injury. Remove all rings, watches and other jewelry.

- 9 Pull the cables out of the platform control box.
- 10 Pull all of the electrical cables out of the plastic cable track. Do not pull out the hydraulic hoses.
- 11 Remove the hose clamps from the bottom side of the primary boom.
- 12 Tag, disconnect and plug the hydraulic hoses at the union located on the bottom side of the primary boom. Cap the fittings on the union.

⚠WARNING Bodily injury hazard. Spraying hydraulic oil can penetrate and burn skin. Loosen hydraulic connections very slowly to allow the oil pressure to dissipate gradually. Do not allow oil to squirt or spray.

- 13 Remove the hose clamp from the side of the primary boom at the pivot end.

SECONDARY BOOM COMPONENTS

REV A

- 14 Remove the primary boom extend drive speed limit switch mounted on the side of the primary boom at the pivot end. Do not disconnect the wiring.
- 15 Attach a lifting strap from an overhead crane to the pivot end of the primary boom.
- 16 Using the overhead crane, carefully lift the secondary and primary boom assembly until the master cylinder and primary boom lift cylinder hydraulic hoses are accessible.
- 17 Remove the cable covers from the top of the upper secondary boom.
- 18 Tag, disconnect and plug the primary boom lift cylinder and master cylinder hydraulic hoses. Cap the fittings on the cylinders.

WARNING Bodily injury hazard. Spraying hydraulic oil can penetrate and burn skin. Loosen hydraulic connections very slowly to allow the oil pressure to dissipate gradually. Do not allow oil to squirt or spray.

- 19 Using the overhead crane, lower the boom assembly to the fully stowed position.
- 20 Pull all the cables and hoses through the upper pivot.

NOTICE Component damage hazard. Cables and hoses can be damaged if they are kinked or pinched.

- 21 Position a lifting strap from the overhead crane approximately 2 feet / 60 cm from the platform end of the primary boom. Measure from the platform end of the primary boom tube.
- 22 Remove the pin retaining fasteners from the upper pivot to upper secondary compression arm pivot pins. Place a rod through the compression arm pivot pin and twist to remove the pins.
- 23 Swing the compression arms down and out of the way. Secure them from moving.
- 24 Remove the pin retaining fasteners from the upper pivot to the upper secondary boom pivot pin. Use a soft metal drift to remove the pin.
- 25 Carefully remove the entire primary boom assembly from the machine (primary boom assembly, jib boom assembly, platform, master cylinder, primary lift cylinder and upper pivot).

WARNING Crushing hazard. The primary boom assembly could become unbalanced and fall when removed from the machine if not properly supported by the overhead crane. Do not remove the assembly from the machine until it is properly balanced.

Note: During removal, the overhead crane strap will need to be carefully adjusted for proper balancing.

- 26 Place the entire assembly onto a structure capable of supporting it.

REV A

SECONDARY BOOM COMPONENTS

27 Remove the pin retaining fasteners from the upper secondary compression arm pivot pins. Do not remove the pins.

28 Position a lifting strap from an overhead crane at the center of the control box side upper compression arm.

29 Place a rod through the compression arm pivot pin and twist to remove the pin. Remove the compression arm from the machine.

WARNING Crushing hazard. The upper compression arm could become unbalanced and fall when removed from the machine if not properly supported by the overhead crane.

30 Repeat step 29 for the engine side upper compression arm.

31 Remove the plastic plug in the bulkhead to access the secondary boom lift cylinder rod-end pivot pin.

32 Remove the pin retaining fasteners from the rod end of the secondary boom lift cylinder. Use a soft metal drift to remove the pin. Secure the cylinder from moving.

33 Remove the pin retaining fasteners from the lower pivot pin of the compression link. Use a soft metal drift to remove the pin.

34 Attach a lifting strap from an overhead crane to the upper secondary boom.

35 Remove the pin retaining fasteners from the mid-pivot to upper secondary boom pivot pin. Use a soft metal drift to remove the pin.

36 Remove the upper secondary boom with compression link from the machine.

WARNING Crushing hazard. The upper secondary boom with compression link could become unbalanced and fall when removed from the machine if not properly supported by the overhead crane.

37 Remove the drive speed limit switch mounted on the inside of the lower mid-pivot. Do not disconnect the wiring.

38 Remove the cable covers from the top of the lower secondary boom. Pull all the cables and hoses towards the counterweight end of the turntable.

39 **Gasoline/LPG models:** Remove the LPG hose from the tank and then remove the LPG tank.

40 Remove the battery hold down and battery.

41 Remove the pin retaining fasteners from the secondary boom lift cylinder barrel-end pivot pins.

SECONDARY BOOM COMPONENTS

REV A

42 Attach a lifting strap from an overhead crane to the lug on the rod-end of the secondary boom lift cylinder.

43 Tag, disconnect and plug the hydraulic hoses from the secondary boom lift cylinder. Cap the fittings on the cylinder.

WARNING Bodily injury hazard. Spraying hydraulic oil can penetrate and burn skin. Loosen hydraulic connections very slowly to allow the oil pressure to dissipate gradually. Do not allow oil to squirt or spray.

44 Use a slide hammer to remove the secondary boom lift cylinder barrel-end pivot pins. Remove the secondary boom lift cylinder from the machine.

WARNING Crushing hazard. The secondary boom lift cylinder could become unbalanced and fall when removed from the machine if not properly supported by the overhead crane.

Note: Access the pins using the access holes located in the bulkheads, one on each side.

45 Attach a lifting strap from an overhead crane to the mid-pivot for support. Do not lift it.

46 Remove the pin retaining fasteners from the mid-pivot to lower compression arm pivot pins. Place a rod through the compression arm pivot pins and twist to remove the pins.

47 Remove the pin retaining fasteners from the mid-pivot to lower secondary boom pivot pins. Use a soft metal drift to remove the pin.

48 Remove the mid-pivot from the machine.

WARNING Crushing hazard. The mid-pivot could become unbalanced and fall when removed from the machine if not properly supported by the overhead crane.

49 Attach a lifting strap from an overhead crane to the control box side lower compression arm.

50 Remove the pin retaining fasteners from the lower compression arm to turntable pivot pins. Place a rod through the compression arm pivot pin and twist to remove the pin. Remove the compression arm from the machine.

WARNING Crushing hazard. The lower compression arm could become unbalanced and fall when removed from the machine if not properly supported by the overhead crane.

51 Repeat step 50 for the engine side lower compression arm.

52 Attach a lifting strap from an overhead crane to the lower secondary boom.

53 Remove the pin retaining fasteners from the lower secondary boom to turntable pivot pin. Use a soft metal drift to remove the pin.

54 Remove the lower secondary boom from the machine.

WARNING Crushing hazard. The lower secondary boom could become unbalanced and fall when removed from the machine if not properly supported by the overhead crane.

REV A

SECONDARY BOOM COMPONENTS

5-2 Secondary Boom Lift Cylinder

The secondary boom lift cylinder raises and lowers the secondary boom. The secondary boom lift cylinder is equipped with counterbalance valves to prevent movement in the event of a hydraulic line failure.

How to Remove the Secondary Boom Lift Cylinder

⚠WARNING Bodily injury hazard. This procedure requires specific repair skills, lifting equipment and a suitable workshop. Attempting this procedure without these skills and tools could result in death or serious injury and significant component damage. Dealer service is strongly recommended.

Note: When removing a hose assembly or fitting, the O-ring on the fitting and/or hose end must be replaced and then torqued to specification during installation. Refer to Section 2, *Hydraulic Hose and Fitting Torque Specifications*.

- 1 Rotate the turntable to the side until the boom is centered between the steer and non-steer tires.
- 2 Raise the primary boom to full height. Do not extend it. Turn the machine off.
- 3 Attach a lifting strap from an overhead crane to the lug on the rod-end of the secondary boom lift cylinder.

- 4 Open the engine side turntable cover. Pull up on the engine tray lock pin and swing the engine tray out and away from the machine. Secure the engine tray from moving.
- 5 Remove the pin retaining fasteners from the secondary boom lift cylinder barrel-end pivot pins.
- 6 Use a slide hammer to remove the barrel-end pivot pins.

Note: Access the pins using the access holes located in the bulkheads, one on each side.

- 7 Remove the pin retaining fasteners from the secondary boom lift cylinder rod-end pivot pin. Use a soft metal drift to remove the pin.
- 8 Carefully lower the cylinder down through the secondary boom, just enough to access the hydraulic hoses.

NOTICE Component damage hazard. Hoses can be damaged if they are kinked or pinched.

- 9 Tag, disconnect and plug the hydraulic hoses from the secondary boom lift cylinder. Cap the fittings on the cylinder.

⚠WARNING Bodily injury hazard. Spraying hydraulic oil can penetrate and burn skin. Loosen hydraulic connections very slowly to allow the oil pressure to dissipate gradually. Do not allow oil to squirt or spray.

- 10 Carefully remove the cylinder by raising it through the top of the secondary boom using the overhead crane.

⚠WARNING Crushing hazard. The secondary boom lift cylinder could become unbalanced and fall when removed from the machine if not properly supported by the overhead crane.

Kubota D-905 Engine

REV A

6-1 Timing Adjustment

Complete information to perform this procedure is available in the *Kubota D-905 Workshop Manual* (Kubota part number: 97897-02432).

Kubota D905 Workshop Manual	
Genie part number	31742

6-2 Glow Plugs

How to Check the Glow Plugs

- 1 Connect the leads from an ohmmeter between the far left glow plug and ground.
- ⊙ Result: The resistance should be approximately 1Ω.
- 2 If the ohm reading is different than 1Ω, remove the wire and connector plate from the three individual glow plugs. Then, one glow plug at a time, measure the resistance between the glow plug and ground.
- ⊙ Result: The resistance should be approximately 1.8Ω for each individual glow plug.
- 3 Install the connector plate and wires to all three glow plugs.
- 4 Turn the key switch to ground control and pull out the red Emergency Stop button to the on position.
- 5 Connect the red positive (+) lead from a volt meter to the number three glow plug. Connect the black negative (-) lead to ground.
- 6 Hold the glow plug switch in the on position.
- ⊙ Result: The volt meter should read 12V DC or more.

6-3 RPM Adjustment

Refer to maintenance procedure B-9, *Check and Adjust the Engine RPM*.

6-4 Flex Plate

The flex plate acts as a coupler between the engine and the pump. It is bolted to the engine flywheel and has a splined center to drive the pump.

How to Remove the Flex Plate

- 1 Support the drive pump with an appropriate lifting device.
- 2 Remove all of the pump mounting plate to engine bell housing bolts.
- 3 Carefully pull the pump away from the engine and secure it from moving.
- 4 Remove the flex plate mounting fasteners. Remove the flex plate from the engine.

REV A

KUBOTA D-905 ENGINE

How to Install the Flex Plate

- 1 Install the flex plate onto the flywheel with the raised spline away from the flywheel.

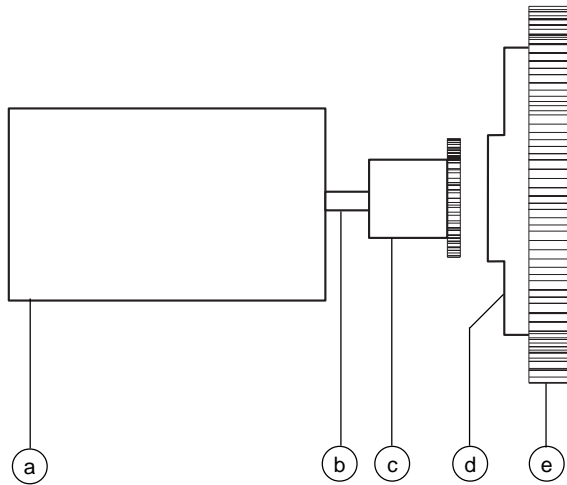

- a pump
- b pump shaft
- c pump coupler
- d flex plate
- e flywheel

- 2 Apply removable Loctite® thread sealant to the flex plate mounting fasteners. Torque the flex plate mounting fasteners to 36 ft-lbs / 49 Nm.
- 3 Install the coupler onto the pump shaft with the set screw towards the pump. Leave a $\frac{1}{32}$ inch / 0.8 mm gap between the coupler and pump end plate.
- 4 Apply removable Loctite® thread sealant to the coupler set screw. Torque the set screw to 65-70 ft-lbs / 88-95 Nm.

NOTICE Component damage hazard. Do not force the drive pump during installation or the flex plate teeth may become damaged.

6-5 Coolant Temperature and Oil Pressure Switches

The engine coolant temperature switch is a normally open switch. The switch contacts close at approximately 225°F / 107°C. If the coolant temperature rises above the switch point, the switch contacts close and the engine will shut off to prevent damage. The engine will not start until the temperature drops below the switch point. An over-temperature indicator light at the ground controls should turn on when the switch closes.

NOTICE Component damage hazard. Do not crank the engine with the over-temperature light on.

The engine oil switch is a normally closed switch. The switch contacts open at approximately 7 psi / 0.48 bar. If the oil pressure drops below the switch point, the contacts open and the engine will shut off to prevent damage. A low oil pressure indicator light at the ground controls should turn on when the switch opens.

NOTICE Component damage hazard. Do not crank the engine with the low oil pressure light on.

Kubota DF752 Engine

REV A

7-1 Choke Adjustments

The choke is solenoid-operated and functions only in the gasoline mode. This choke will not operate in LPG mode.

Note: Choke adjustments are affected by climate. Richer adjustment will be necessary in colder climates, leaner adjustment in warmer climates.

7-2 Timing Adjustment

Note: The ignition timing cannot be adjusted. The timing adjustment screw is factory sealed with a tamper resistant cap installed by the manufacturer. If service or repair is needed, contact your local Kubota dealer.

7-3 Carburetor Adjustment

Note: The carburetor cannot be adjusted. The carburetor mixture screws are factory sealed with tamper resistant caps installed by the manufacturer. If service or repair is needed, contact your local Kubota dealer.

7-4 RPM Adjustment

Refer to maintenance procedure B-9, *Check and Adjust the Engine RPM*.

7-5 Flex Plate

The flex plate acts as a coupler between the engine and the pump. It is bolted to the engine flywheel and has a splined center to drive the pump.

How to Remove the Flex Plate

- 1 Support the drive pump with a suitable lifting device.
- 2 Remove all of the pump mounting plate to engine fasteners.
- 3 Carefully pull the pump assembly away from the engine and secure it from moving.
- 4 Remove the flex plate mounting fasteners. Remove the flex plate from the flywheel.

REV A

KUBOTA DF752 ENGINE

How to Install the Flex Plate

- 1 Install the flex plate onto the flywheel with the raised spline against the flywheel.

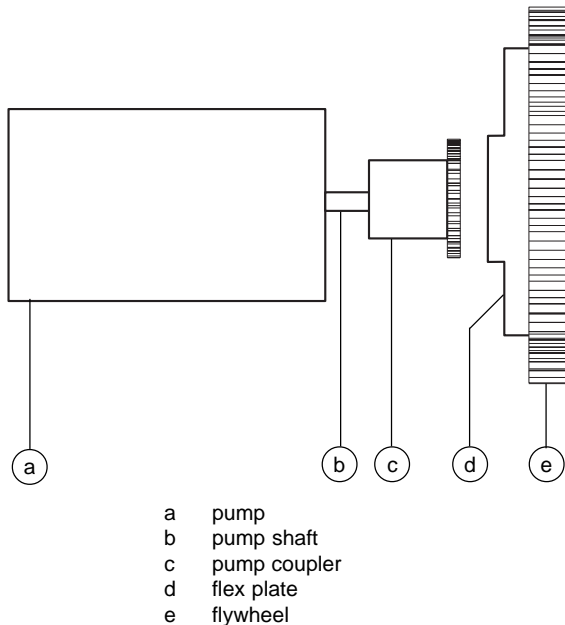

- 2 Apply removable Loctite® thread sealant to the flex plate mounting fasteners. Torque the flex plate mounting fasteners to 36 ft-lbs / 49 Nm.
- 3 Install the coupler onto the pump shaft with the set screw towards the pump. Leave a $\frac{1}{32}$ inch / 0.8 mm gap between the coupler and pump end plate.
- 4 Apply removable Loctite® thread sealant to the coupler set screw. Torque the set screw to 65-70 ft-lbs / 88-95 Nm.

NOTICE Component damage hazard. Do not force the drive pump during installation or the flex plate teeth may become damaged.

7-6

Coolant Temperature and Oil Pressure Switches

The engine coolant temperature switch is a normally open switch. The switch contacts close at approximately 225°F / 107°C. If the coolant temperature rises above the switch point, the switch contacts close and the engine will shut off to prevent damage. The engine will not start until the temperature drops below the switch point. An over-temperature indicator light at the ground controls should turn on when the switch closes.

NOTICE Component damage hazard. Do not crank the engine with the over-temperature light on.

The engine oil switch is a normally closed switch. The switch contacts open at approximately 7 psi / 0.48 bar. If the oil pressure drops below the switch point, the contacts open and the engine will shut off to prevent damage. A low oil pressure indicator light at the ground controls should turn on when the switch opens.

NOTICE Component damage hazard. Do not crank the engine with the low oil pressure light on.

Perkins 403C-11 Engine

REV A

8-1 Timing Adjustment

Complete information to perform this procedure is available in the *Perkins 403C-11 Workshop Manual* (Perkins part number TPD1458).

Perkins 403C-11 Workshop Manual
Genie part number 84817

8-2 RPM Adjustment

Refer to maintenance procedure B-9, *Check and Adjust the Engine RPM*.

8-3 Flex Plate

The flex plate acts as a coupler between the engine and the pump. It is bolted to the engine flywheel and has a splined center to drive the pump.

How to Remove the Flex Plate

- 1 Support the drive pump with a suitable lifting device.
- 2 Remove all of the pump mounting plate to engine fasteners.
- 3 Carefully pull the pump assembly away from the engine and secure it from moving.
- 4 Remove the flex plate mounting fasteners. Remove the flex plate from the flywheel.

REV A

PERKINS 403C-11 ENGINE

How to Install the Flex Plate

- 1 Install the flex plate onto the flywheel with the raised spline against the flywheel.

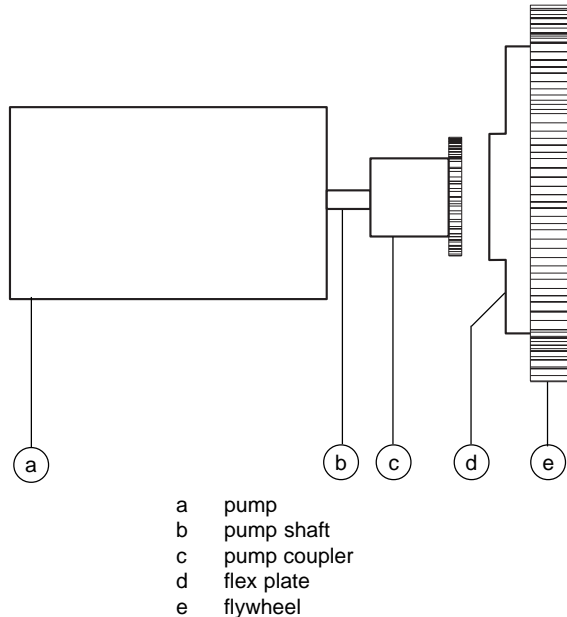

- 2 Apply removable Loctite® thread sealant to the flex plate mounting fasteners. Torque the flex plate mounting fasteners to 36 ft-lbs / 49 Nm.
- 3 Install the coupler onto the pump shaft with the set screw towards the pump. Leave a $\frac{1}{32}$ inch / 0.8 mm gap between the coupler and pump end plate.
- 4 Apply removable Loctite® thread sealant to the coupler set screw. Torque the set screw to 65-70 ft-lbs / 88-95 Nm.

NOTICE Component damage hazard. Do not force the drive pump during installation or the flex plate teeth may become damaged.

8-4

Coolant Temperature and Oil Pressure Switches

The engine coolant temperature switch is a normally open switch. The switch contacts close at approximately 221°F / 105°C. If the coolant temperature rises above the switch point, the switch contacts close and the engine will shut off to prevent damage. The engine will not start until the temperature drops below the switch point.

NOTICE Component damage hazard. Do not crank the engine with the over-temperature light on.

The engine oil pressure switch is a normally open switch. The switch contacts close at approximately 4.27 psi / 0.3 bar. If the oil pressure drops below the switch point, the contacts close and the engine will shut off to prevent damage.

NOTICE Component damage hazard. Do not crank the engine with the low oil pressure light on.

Hydraulic Pumps

REV A

9-1 Auxiliary Pump

How to Test the Auxiliary Pump

Note: When removing a hose assembly or fitting, the O-ring on the fitting and/or hose end must be replaced and then torqued to specification during installation. Refer to Section 2, *Hydraulic Hose and Fitting Torque Specifications*.

- 1 Tag, disconnect and plug the high pressure hydraulic hose from the auxiliary pump.

⚠ WARNING Bodily injury hazard. Spraying hydraulic oil can penetrate and burn skin. Loosen hydraulic connections very slowly to allow the oil pressure to dissipate gradually. Do not allow oil to squirt or spray.

- 2 Connect a 0 to 5000 psi / 0 to 350 bar pressure gauge to the high pressure port on the pump.
- 3 Turn the key switch to ground control and pull out the red Emergency Stop button to the on position at both the ground and platform controls.
- 4 Activate any function using auxiliary power.
- ⊕ Result: The pressure gauge reads 2800 psi / 193 bar, immediately stop. The pump is good.
- ⊗ Result: The pressure fails to reach 2800 psi / 193 bar, the pump is faulty and will need to be serviced or replaced.
- 5 Remove the pressure gauge and install the hydraulic hose.

How to Remove the Auxiliary Pump

Note: When removing a hose assembly or fitting, the O-ring on the fitting and/or hose end must be replaced and then torqued to specification during installation. Refer to Section 2, *Hydraulic Hose and Fitting Torque Specifications*.

- 1 Tag, disconnect and plug the hydraulic hoses from the pump.

⚠ WARNING Bodily injury hazard. Spraying hydraulic oil can penetrate and burn skin. Loosen hydraulic connections very slowly to allow the oil pressure to dissipate gradually. Do not allow oil to squirt or spray.

- 2 Remove the pump mounting fasteners. Carefully remove the pump.

REV A

HYDRAULIC PUMPS

9-2 Function Pump

How to Test the Function Pump

Note: When removing a hose assembly or fitting, the O-ring on the fitting and/or hose end must be replaced and then torqued to specification during installation. Refer to Section 2, *Hydraulic Hose and Fitting Torque Specifications*.

- 1 Tag, disconnect and plug the high pressure hydraulic hose from the function pump.

WARNING Bodily injury hazard. Spraying hydraulic oil can penetrate and burn skin. Loosen hydraulic connections very slowly to allow the oil pressure to dissipate gradually. Do not allow oil to squirt or spray.

- 2 Connect a 0 to 5000 psi / 0 to 350 bar pressure gauge to the high pressure port on the pump.
- 3 **Gasoline/LPG models:** Disconnect the ignition coil wire from the center of the ignition coil.
Diesel models: Hold the manual fuel shutoff lever clockwise to the closed position.
- 4 Turn the key switch to ground control and pull the Emergency Stop button to the on position at both the ground and platform controls.

- 5 Observe the pressure gauge while cranking the engine. Immediately stop if the pressure reaches or exceeds 3000 psi / 206 bar.
- ⊙ Result: The pressure gauge reads 3000 psi / 206 bar, immediately stop cranking the engine. The pump is good.
 - ⊗ Result: The pressure fails to reach 3000 psi / 206 bar, the pump is faulty and will need to be serviced or replaced.

NOTICE Component damage hazard. Hydraulic pressure in excess of 3000 psi / 206 bar may result in severe component damage.

- 6 Remove the pressure gauge and install the hydraulic hose.
- 7 **Gasoline/LPG models:** Install the ignition coil wire to the center of the ignition coil.
Diesel models: Release the manual fuel shutoff lever.

How to Remove the Function Pump

Note: When removing a hose assembly or fitting, the O-ring on the fitting and/or hose end must be replaced and then torqued to specification during installation. Refer to Section 2, *Hydraulic Hose and Fitting Torque Specifications*.

- 1 Tag, disconnect and plug the hydraulic hoses from the pump.

WARNING Bodily injury hazard. Spraying hydraulic oil can penetrate and burn skin. Loosen hydraulic connections very slowly to allow the oil pressure to dissipate gradually. Do not allow oil to squirt or spray.

- 2 Remove the pump mounting fasteners. Carefully remove the pump.

HYDRAULIC PUMPS

REV A

9-3 Drive Pump

The drive pump is a bi-directional variable displacement piston pump. The pump output is controlled by a non-feedback, proportional electrical displacement controller (NFPE), located on the pump. The only adjustment that can be made to the pump is the neutral or null adjustment. Any internal service to the pump should only be performed at an authorized Sauer Danfoss service center.

How to Remove the Drive Pump

NOTICE Component damage hazard. The work area and surfaces where this procedure will be performed must be clean and free of debris that could get into the hydraulic system that could result in severe component damage. Dealer service is recommended.

Note: When removing a hose assembly or fitting, the O-ring on the fitting and/or hose end must be replaced and then torqued to specification during installation. Refer to Section 2, *Hydraulic Hose and Fitting Torque Specifications*.

Before serial number 3364:

- 1 Close the two hydraulic tank shut-off valves at the hydraulic tank.

NOTICE Component damage hazard. The engine must not be started with the hydraulic tank shut-off valves in the closed position or component damage will occur. If the tank valves are closed, remove the key from the key switch and tag the machine to inform personnel of the condition.

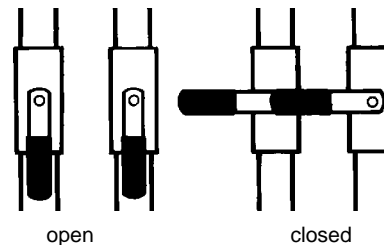

After serial number 3363:

- 1 Remove the drain plug from the hydraulic tank and completely drain the tank into a container of suitable capacity. Refer to Section 2, *Specifications*.

CAUTION Bodily injury hazard. Beware of hot oil. Contact with hot oil may cause severe burns.

REV A

HYDRAULIC PUMPS

All models:

- 2 Disconnect the electrical connectors from the coils of the NFPE controller (NFPE) located on the drive pump.
- 3 Tag, disconnect and plug the hydraulic hoses from the pump.

AWARNING Bodily injury hazard. Spraying hydraulic oil can penetrate and burn skin. Loosen hydraulic connections very slowly to allow the oil pressure to dissipate gradually. Do not allow oil to squirt or spray.

- 4 Support the pump with a suitable lifting device.
- 5 Remove the drive pump mounting bolts. Carefully remove the pump.

How to Prime the Pump

- 1 Connect a 0 to 6000 psi / 0 to 414 bar pressure gauge to the test port on the drive pump.
- 2 **Gasoline/LPG models:** Disconnect the ignition coil wire from the center of the ignition coil.
Diesel models: Hold the manual fuel shutoff lever clockwise to the closed position.
- 3 Crank the engine with the starter motor for 15 seconds, wait 15 seconds, then crank the engine an additional 15 seconds or until the pressure reaches 320 psi / 22 bar.

Manifolds

REV A

10-1

Function Manifold Components

The function manifold is mounted to the turntable under the ground control box.

Index No.	Description	Schematic		Torque
		Item	Function	
1	Counterbalance valve, 3000 psi / 207 bar	F	Platform level up	25-30 ft-lbs / 34-41 Nm
2	Counterbalance valve, 3000 psi / 207 bar	G	Platform level down	25-30 ft-lbs / 34-41 Nm
3	Counterbalance valve, 1500 psi / 103 bar	H	Turntable rotate left	25-30 ft-lbs / 34-41 Nm
4	Counterbalance valve, 1500 psi / 103 bar	I	Turntable rotate right	25-30 ft-lbs / 34-41 Nm
5	Relief valve, 1600 psi / 110 bar	J	Secondary boom down	25-30 ft-lbs / 34-41 Nm
6	Relief valve, 1600 psi / 110 bar	K	Primary boom down	25-30 ft-lbs / 34-41 Nm
7	Proportional solenoid valve	D	System flow regulating circuit	35-40 ft-lbs / 47-54 Nm
8	Solenoid valve, 3 position 4 way	E	Steer left/right	10-12 ft-lbs / 14-16 Nm
9	Flow regulator valve, 0.1 gpm / 0.38 L/min	V	Differential sensing circuit	35-40 ft-lbs / 47-54 Nm
10	Differential sensing valve	C	All functions	35-40 ft-lbs / 47-54 Nm
11	Diagnostic fitting		Testing	
12	Priority flow regulator valve, 1 gpm / 3.8 L/min	A	Steering	34-40 ft-lbs / 47-54 Nm
13	Relief valve, 3200 psi / 221 bar	B	System relief	25-30 ft-lbs / 34-41 Nm
14	Solenoid valve, 2 position 3 way	U	Primary boom retract	8-10 ft-lbs / 11-14 Nm
15	Solenoid valve, 2 position 3 way	R	Primary boom up	8-10 ft-lbs / 11-14 Nm

This list continues. Please turn the page.

REV A

MANIFOLDS

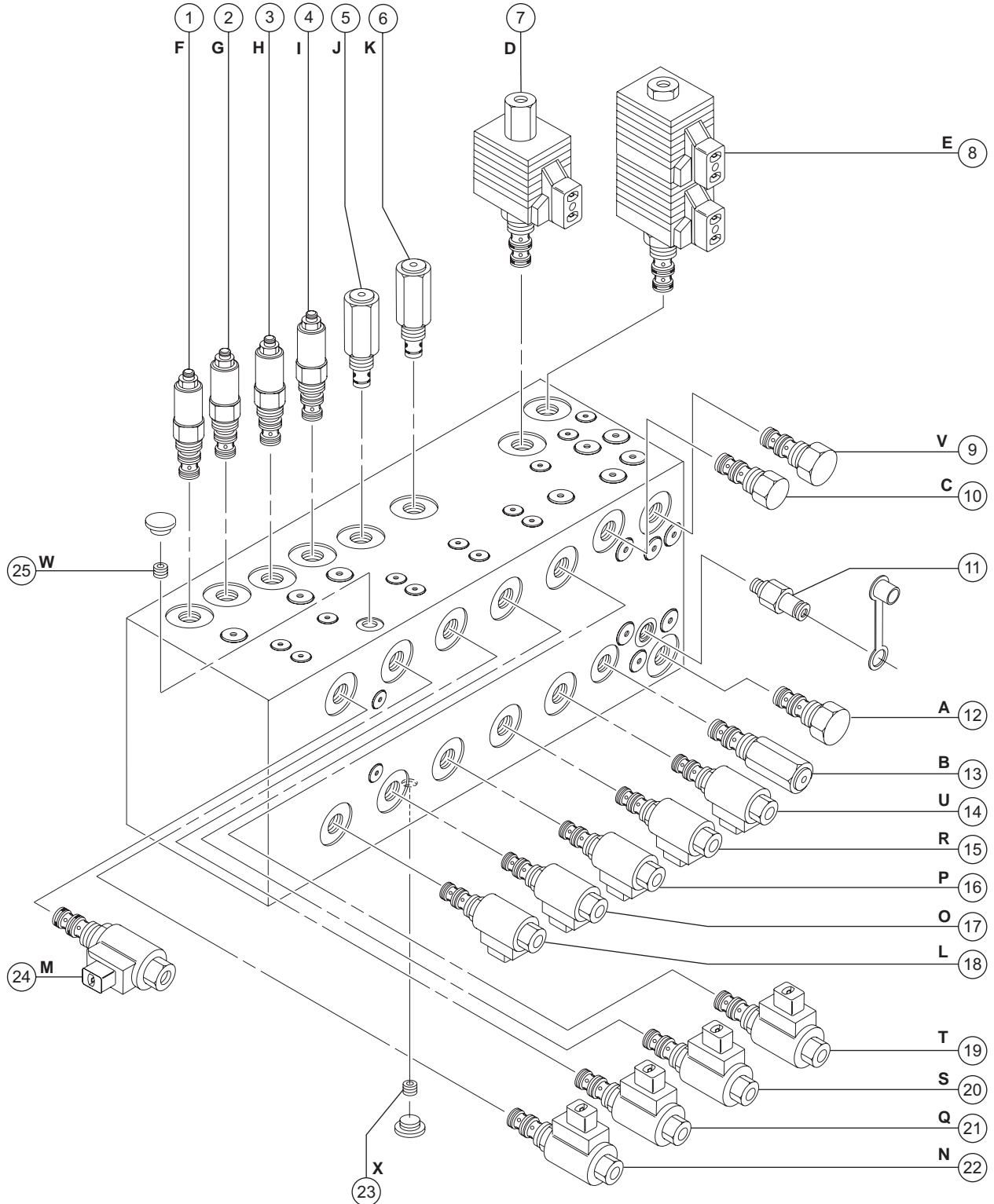

MANIFOLDS

REV A

Function Manifold Components, continued

The function manifold is mounted to the turntable under the ground control box.

Index No.	Description	Schematic		Torque
		Item	Function	
16	Solenoid valve, 2 position 3 way	P	Secondary boom up	8-10 ft-lbs / 11-14 Nm
17	Solenoid valve, 2 position 3 way	O	Turntable rotate left	8-10 ft-lbs / 11-14 Nm
18	Solenoid valve, 2 position 3 way	L	Platform level up	8-10 ft-lbs / 11-14 Nm
19	Solenoid valve, 2 position 3 way	T	Primary boom extend	8-10 ft-lbs / 11-14 Nm
20	Solenoid valve, 2 position 3 way	S	Primary boom down	8-10 ft-lbs / 11-14 Nm
21	Solenoid valve, 2 position 3 way	Q	Secondary boom down	8-10 ft-lbs / 11-14 Nm
22	Solenoid valve, 2 position 3 way	N	Turntable rotate right	8-10 ft-lbs / 11-14 Nm
23	Orifice, 0.052 inch / 1.32 mm	X	Turntable rotate circuit	
24	Solenoid valve, 2 position 3 way	M	Platform level down	8-10 ft-lbs / 11-14 Nm
25	Orifice, 0.052 inch / 1.32 mm	W	Turntable rotate circuit	

REV A

MANIFOLDS

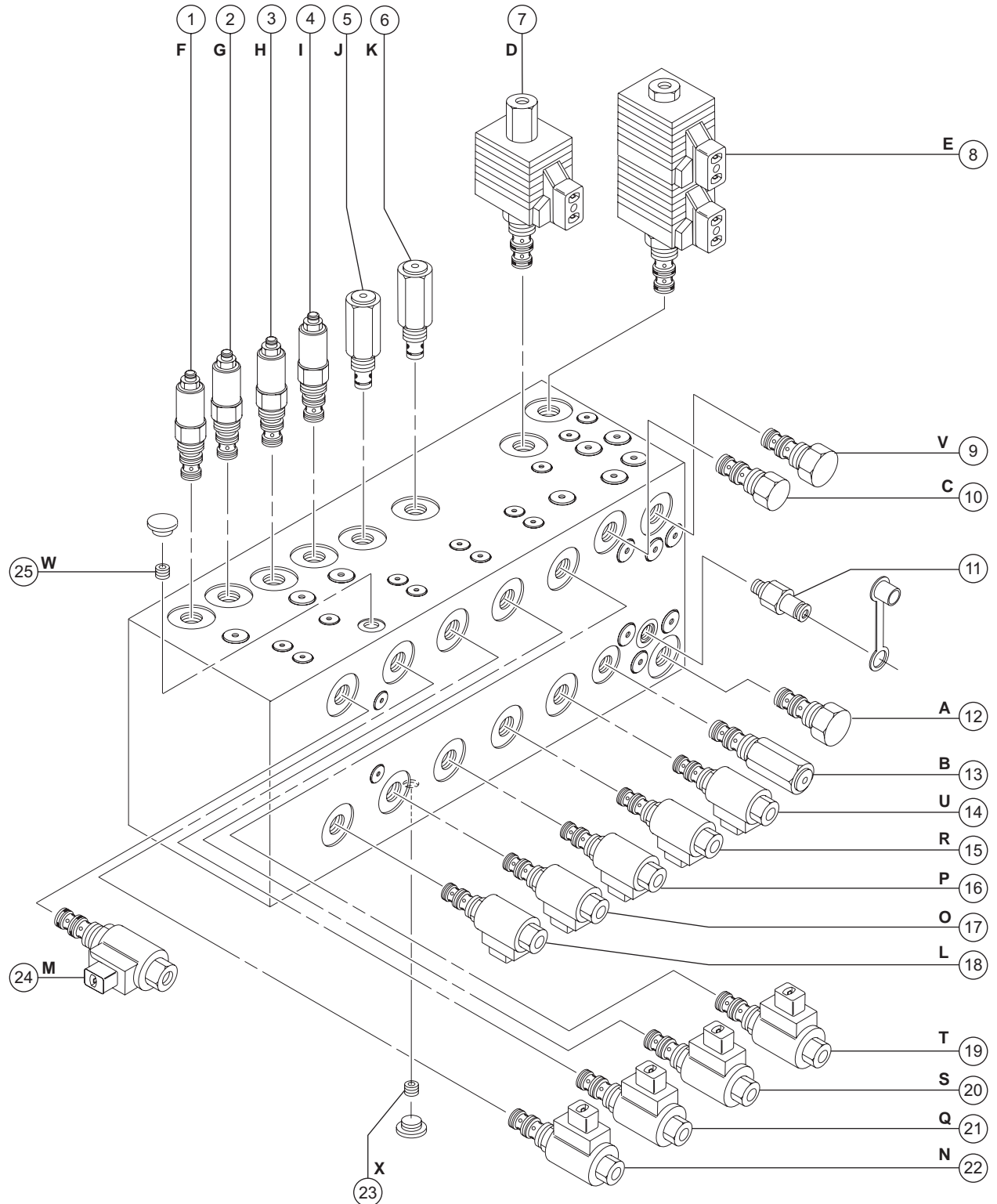

MANIFOLDS

REV A

10-2 Valve Adjustments - Function Manifold

How to Adjust the Primary Boom Down Relief Valve

- 1 Connect a 0 to 3000 psi / 0 to 206 bar pressure gauge to the test port on the function manifold.
- 2 Start the engine from the ground controls.
- 3 Hold the function enable/rpm select toggle switch to the high rpm position and activate and hold the primary boom toggle switch in the down direction with the primary boom fully lowered.
- 4 Observe the pressure reading on the pressure gauge. Refer to Section 2, *Specifications*.
- 5 Turn the machine off. Hold the relief valve and remove the cap (item K).
- 6 Adjust the internal hex socket. Turn it clockwise to increase the pressure or counterclockwise to decrease the pressure. Install the relief valve cap.

▲WARNING Tip-over hazard. Do not adjust the relief valve higher than specified.

- 7 Repeat steps 2 through 6 to confirm the relief valve pressure setting.

How to Adjust the Secondary Boom Down Relief Valve

- 1 Connect a 0 to 3000 psi / 0 to 206 bar pressure gauge to the test port on the function manifold.
 - 2 Start the engine from the ground controls.
 - 3 Hold the function enable/rpm select toggle switch to the high rpm position and activate and hold the secondary boom toggle switch in the down direction with the secondary boom fully lowered.
 - 4 Observe the pressure reading on the pressure gauge. Refer to Section 2, *Specifications*.
 - 5 Turn the machine off. Hold the relief valve and remove the cap (item J).
 - 6 Adjust the internal hex socket. Turn it clockwise to increase the pressure or counterclockwise to decrease the pressure. Install the relief valve cap.
- ▲WARNING** Tip-over hazard. Do not adjust the relief valve higher than specified.
- 7 Repeat steps 2 through 6 to confirm the relief valve pressure setting.

REV A

MANIFOLDS

10-3 Jib Boom / Platform Rotate Manifold Components

The jib boom/platform rotate manifold is mounted to the jib boom.

Index No.	Description	Schematic Item	Function	Torque
1	Solenoid valve, 3 position 4 way	CH	Jib boom up/down	8-10 ft-lbs / 11-14 Nm
2	Solenoid valve, 3 position 4 way	CI	Platform rotate left/right	8-10 ft-lbs / 11-14 Nm
3	Flow regulator valve, 0.3 gpm / 1.14 L/min	CG	Platform rotate circuit	8-10 ft-lbs / 11-14 Nm
4	Orifice plug, 0.028 inch / 0.71 mm (located in "P" port)	CF	Platform rotate and jib boom circuit	

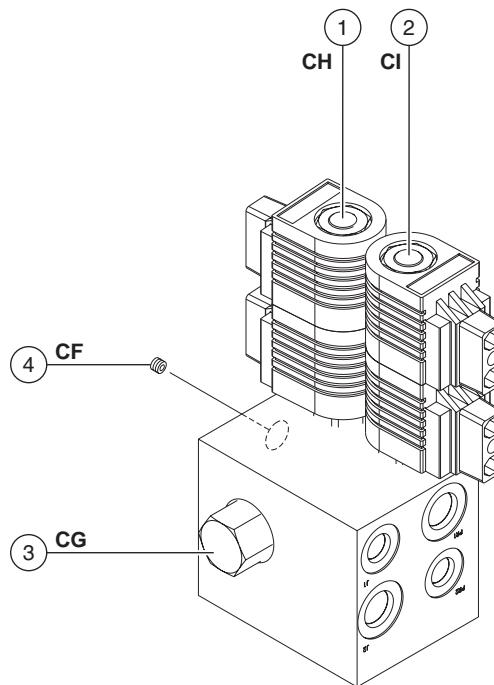

MANIFOLDS

REV A

10-4 Brake / 2-speed Manifold Components, 2WD Models

The brake / 2-speed manifold is located under the drive chassis cover at the non-steer end.

Index No.	Description	Schematic Item	Function	Torque
1	Check Valve	AC	Pressure circuit	8-10 ft-lbs / 10-15 Nm
2	Solenoid valve, 2 position 3 way	AB	2-speed motor shift	25-30 ft-lbs / 34-41 Nm
3	Solenoid valve, 2 position 3 way	AA	Brake	25-30 ft-lbs / 34-41 Nm
4	Orifice Plug, 0.025 inch / 0.64 mm	AD	Tank return circuit	

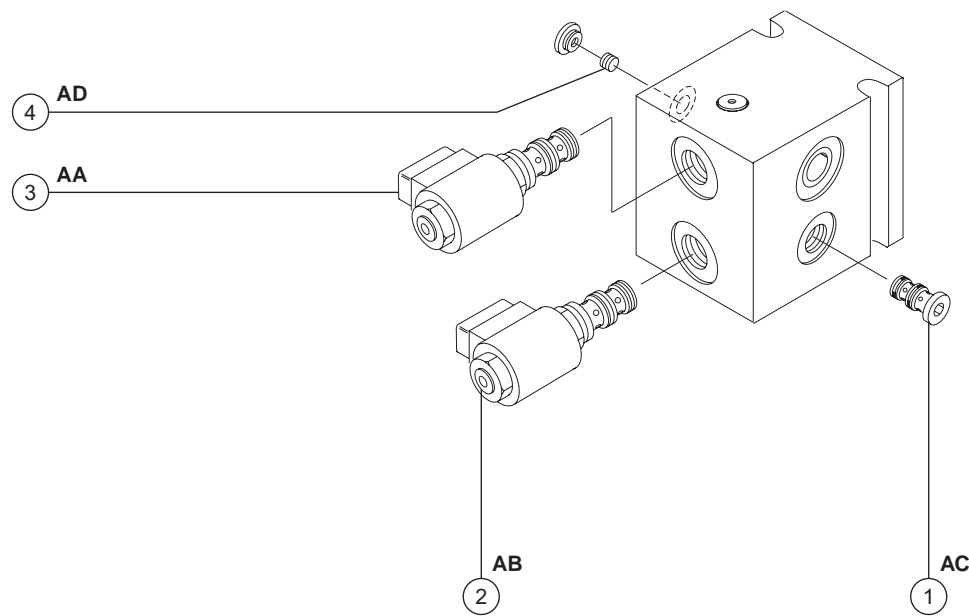

REV A

MANIFOLDS

10-5 2WD Traction Manifold Components

The 2WD traction is mounted inside the drive chassis at the non-steer end.

Index No.	Description	Schematic Item	Function	Torque
1	Shuttle valve, 3 position 3 way	A	Charge pressure circuit that gets hot oil out of low pressure side of drive pump and allows low pressure flow path for brake release and 2-speed motor shift	10-12 ft-lbs / 14-16 Nm
2	Relief valve, 210 psi / 14.5 bar	B	Charge pressure circuit	35-40 ft-lbs / 47-54 Nm
3	Diagnostic fitting		Testing	
4	Flow divider/combiner valve	C	Controls flow to drive motors in forward and reverse	130-140 ft-lbs / 176-190 Nm
5	Orifice 0.070 inch / 1.78 mm	D	Equalizes pressure on both sides divider/combiner valve C.	

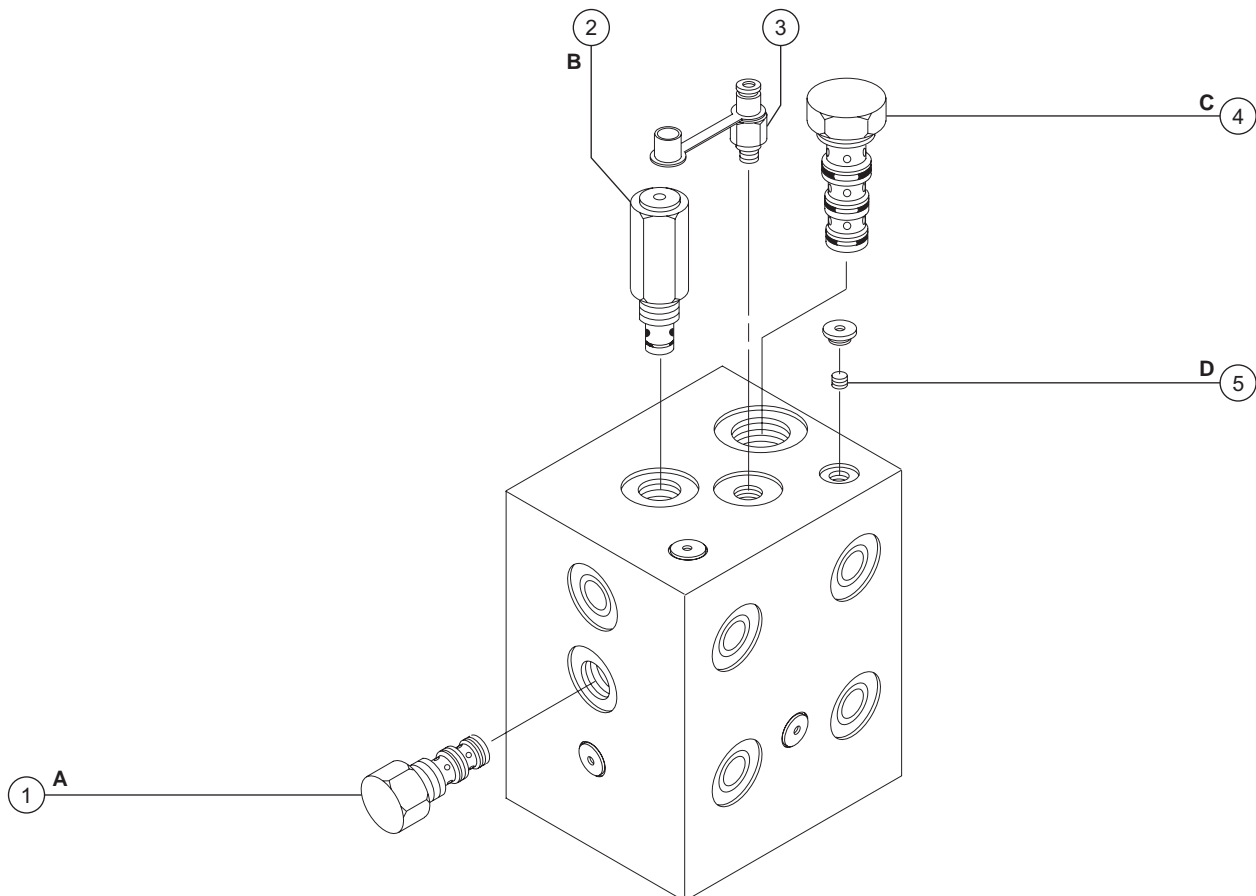

MANIFOLDS

REV A

10-6 4WD Traction Manifold Components

The 4WD traction manifold is mounted inside the drive chassis at the non-steer end.

Index No.	Description	Schematic Item	Function	Torque
1	Solenoid valve, 2 position 3 way	BB	Brake	20 ft-lbs / 27.1 Nm
2	Check valve	BL	Drive motor anti-cavitation	20 ft-lbs / 27.1 Nm
3	Shuttle valve, 3 position 3 way	BK	Charge pressure circuit that gets hot oil out of low pressure side of drive pump and allows low pressure flow path for brake release and 2-speed motor shift	15-18 ft-lbs / 20-24 Nm
4	Solenoid valve, 2 position 3 way	BA	2-speed motor shift	20 ft-lbs / 27.1 Nm
5	Check valve	BF	Drive motor anti-cavitation	20 ft-lbs / 27.1 Nm
6	Orifice plug, 0.039 inch / 1 mm	BP	Equalizes pressure on both sides of flow divider/combiner valve BO	
7	Flow divider/combiner valve	BO	Controls flow to right side drive motors in forward and reverse	25 ft-lbs / 33.9 Nm
8	Orifice plug, 0.039 inch / 1 mm	BQ	Equalizes pressure on both sides of flow divider/combiner valve BO	
9	Check valve	BG	Drive motor anti-cavitation	20 ft-lbs / 27.1 Nm
10	Orifice plug, 0.032 inch / 0.8 mm	BC	Brake circuit	
11	Orifice plug, 0.079 inch / 2 mm	BH	Equalizes pressure on both sides of flow divider/combiner valve BI	
12	Check valve	BM	Drive motor anti-cavitation	20 ft-lbs / 27.1 Nm
13	Check valve	BN	Drive motor anti-cavitation	20 ft-lbs / 27.1 Nm
14	Check valve	BE	Drive motor anti-cavitation	20 ft-lbs / 27.1 Nm
15	Orifice plug, 0.079 inch / 2 mm	BJ	Equalizes pressure on both sides of flow divider/combiner valve BI	
16	Relief valve, 150 psi / 10.3 bar	BD	Charge pressure circuit	20 ft-lbs / 27.1 Nm
17	Orifice plug, 0.039 inch / 1 mm	BS	Equalizes pressure on both sides of flow divider/combiner valve BT	
18	Flow divider/combiner valve	BT	Controls flow to left side drive motors in forward and reverse	25 ft-lbs / 33.9 Nm
19	Orifice plug, 0.039 inch / 1 mm	BR	Equalizes pressure on both sides of flow divider/combiner valve BT	
20	Flow divider/combiner valve	BI	Controls flow to flow divider/combiner valves BO and BT	30 ft-lbs / 40.6 Nm

REV A

MANIFOLDS

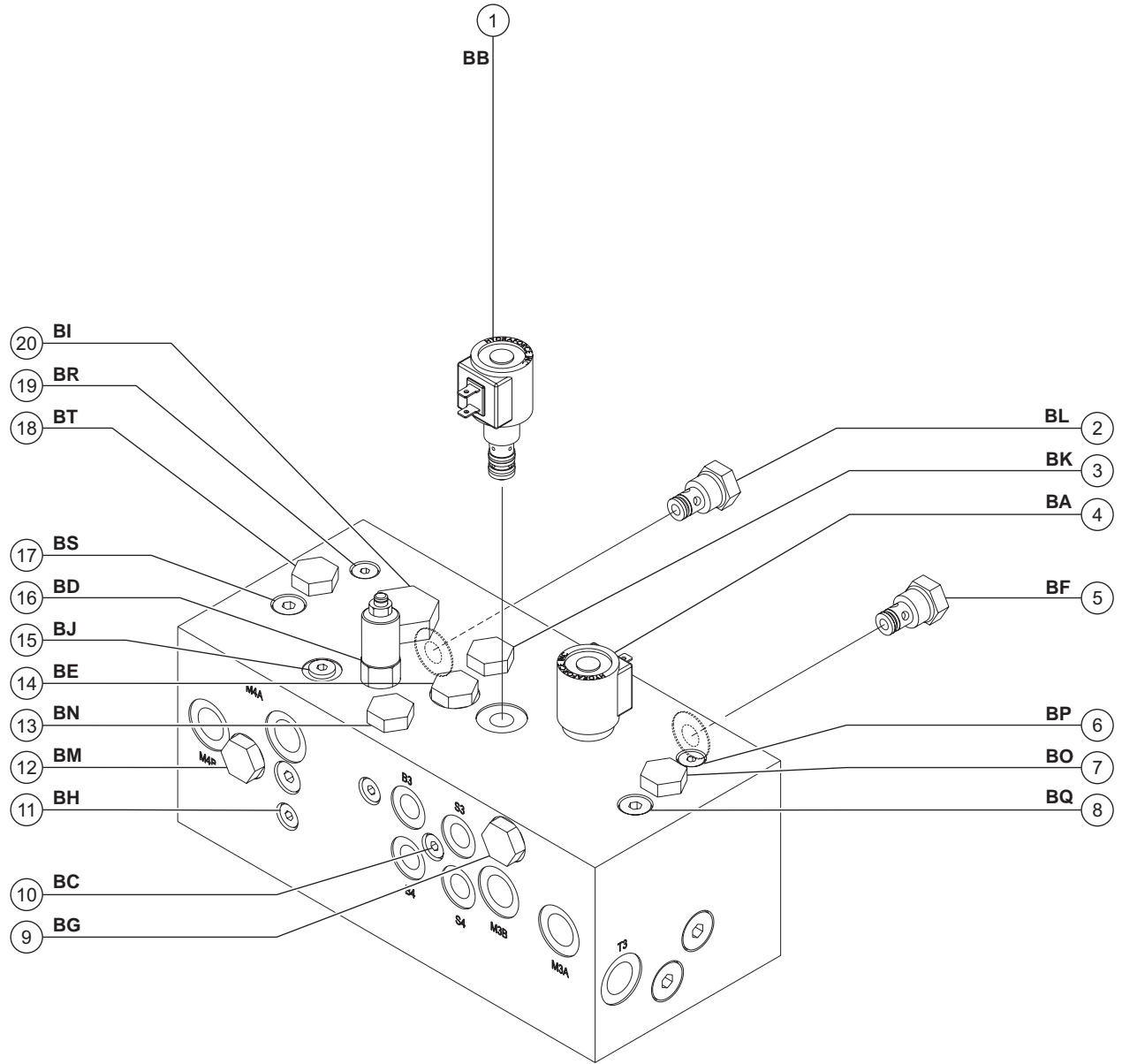

MANIFOLDS

REV A

10-7 Valve Adjustments - Traction Manifold

How to Adjust the Charge Pressure Relief Valve

The charge pressure relief valve needs to be set for machine performance rather than a specific pressure value. The relief valve is set correctly when the engine does not stall when placed under a heavy load.

- 1 Chock both sides of all four wheels of the machine.

Note: Be sure the machine cannot move in either direction.

- 2 Start the engine from the platform controls. Slowly move the drive joystick to full stroke in either direction.
 - ⦿ Result: The engine rpm lowers considerably, as if the engine is under a heavy load, but does not stall. The charge pressure relief valve is set correctly. Proceed to step 8.
 - ⊗ Result: The engine rpm does not lower considerably. The charge pressure relief valve is set too low. Proceed to step 3 to adjust the charge pressure relief valve.
 - ⊗ Result: The engine stalls. The charge pressure relief valve is set too high. Proceed to step 3 to adjust the charge pressure relief valve.

- 3 Turn the engine off. Connect a 0 to 600 psi / 0 to 40 bar pressure gauge to the test port located on the traction manifold.
- 4 Start the engine from the platform controls. Slowly move the drive joystick to full stroke in either direction and observe the pressure reading on the pressure gauge.
 - ⦿ Result: When the charge pressure relief valve is set correctly, the pressure reading on the gauge should be between 135 to 180 psi / 9 to 12 bar.
- 5 Turn the engine off. Hold the relief valve and remove the cap (item B or BD).
- 6 Adjust the internal hex socket. Turn it clockwise to increase the pressure or counterclockwise to decrease the pressure. Install the relief valve cap.
- 7 Repeat this procedure beginning with step 2.
- 8 Remove the wheel chocks.
- 9 Turn the engine off and remove the pressure gauge.

REV A

MANIFOLDS

10-8 Valve Coils

How to Test a Coil

A properly functioning coil provides an electromotive force which operates the solenoid valve. Critical to normal operation is continuity within the coil. Zero resistance indicates the coil has failed.

Since coil resistance is sensitive to temperature, resistance values outside specification can produce erratic operation. When coil resistance decreases below specification, amperage increases. As resistance rises above specification, voltage increases.

While valves may operate when coil resistance is outside specification, maintaining coils within specification will help ensure proper valve function over a wide range of operating temperatures.

⚠ WARNING Electrocutation hazard. Contact with electrically charged circuits could result in death or serious injury. Remove all rings, watches and other jewelry.

- 1 Tag and disconnect the wiring from the coil to be tested.
- 2 Test the coil resistance.

Coils with 2 terminals: Connect the leads from the ohmmeter to the valve coil terminals.

Coils with 1 terminal: Connect the positive lead from the ohmmeter to the valve coil terminal, then connect the negative lead from the ohmmeter to the internal ring of the valve coil.

- ⊙ Result: The resistance should be within specification, plus or minus 30%.
- ⊗ Result: If the resistance is not within specification, plus or minus 30%, replace the coil.

Valve Coil Resistance Specification

Note: The following coil resistance specifications are at an ambient temperature of 68°F / 20°C. As valve coil resistance is sensitive to changes in air temperature, the coil resistance will typically increase or decrease by 4% for each 18°F / -8°C that your air temperature increases or decreases from 68°F / 20°C.

Valve coil specifications

2 position 3 way solenoid valve, 10V DC (schematic items L, M, N, O, P, Q, R, S, T, U, AA, AB, BA and BB)	6Ω
3 position 4 way solenoid valve, 10V DC (schematic item E, CH, CI)	6Ω
Proportional solenoid valve, 12V DC (schematic item D)	5Ω

MANIFOLDS

REV A

How to Test a Coil Diode

Genie incorporates spike suppressing diodes in all of its valve coils. Properly functioning coil diodes protect the electrical circuit by suppressing voltage spikes. Voltage spikes naturally occur within a function circuit following the interruption of electrical current to a coil. Faulty diodes can fail to protect the electrical system, resulting in a tripped circuit breaker or component damage.

⚠ WARNING Electrocutation hazard. Contact with electrically charged circuits could result in death or serious injury. Remove all rings, watches and other jewelry.

- 1 Test the coil for resistance. See *How to Test a Coil*.
- 2 Connect a 10Ω resistor to the negative terminal of a known good 9V DC battery. Connect the other end of the resistor to a terminal on the coil.

Note: The battery should read 9V DC or more when measured across the terminals.

Resistor, 10Ω

Genie part number

27287

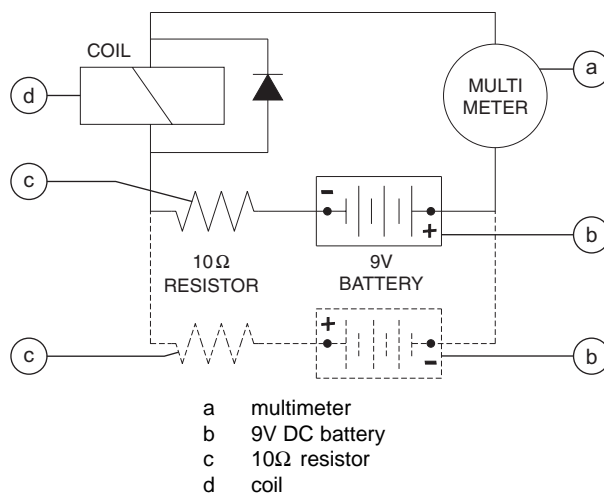

Note: Dotted lines in illustration indicate a reversed connection as specified in step 6

- 3 Set a multimeter to read DC current.

Note: The multimeter, when set to read DC current, should be capable of reading up to 800 mA.

- 4 Connect the negative lead to the other terminal on the coil.

Note: If testing a single-terminal coil, connect the negative lead to the internal metallic ring at either end of the coil.

- 5 Momentarily connect the positive lead from the multimeter to the positive terminal on the 9V DC battery. Note and record the amperage reading.
- 6 At the battery or coil terminals, reverse the connections. Note and record the current reading.

- ☉ Result: Both current readings are greater than 0 mA and are different by a minimum of 20%. The coil is good.
- ☒ Result: If one or both of the current readings are 0 mA, or if the two current readings do not differ by a minimum of 20%, the coil and/or its internal diode are faulty and the coil should be replaced.

Fuel and Hydraulic Tanks

REV A

11-1 Fuel Tank

How to Remove the Fuel Tank

- 1 Raise the secondary boom so the upper pivot is approximately 12 feet / 4 m off the ground.
- 2 **Gasoline/LPG models:** Turn the LPG shutoff valve to the closed position on the LPG tank.
- 3 **Gasoline/LPG models:** Remove the LPG hose from the tank and then remove the tank from the machine.
- 4 **Gasoline/LPG models:** Remove the mounting fasteners from the LPG bottle bracket then remove the bracket from the machine.
- 5 Turn the manual fuel shutoff valve (if equipped) to the closed position on the fuel tank.
- 6 Using an approved hand-operated pump, drain the fuel tank into a suitable container. Refer to Section 2, *Specifications*.

⚠ DANGER Explosion and fire hazard. Engine fuels are combustible. Remove the fuel tank in an open, well-ventilated area away from heaters, sparks, flames and lighted tobacco. Always have an approved fire extinguisher within easy reach.

⚠ DANGER Explosion and fire hazard. When transferring fuel, connect a grounding wire between the machine and pump or container.

Note: Be sure to only use a hand-operated pump suitable for use with gasoline and diesel fuel.

- 7 Tag, disconnect and plug the fuel hoses from the fuel tank. Cap the fittings on the fuel tank. Clean up any fuel that may have spilled.
- 8 Remove the fuel tank retaining plate fasteners at the bulkhead.
- 9 Remove the fuel tank from the machine using an appropriate lifting device.

Note: Clean the fuel tank and inspect for cracks and damage before installing.

FUEL AND HYDRAULIC TANKS

REV A

11-2 Hydraulic Tank

The primary functions of the hydraulic tank are to cool, clean and deaerate the hydraulic fluid during operation. It utilizes internal suction strainers for the pump supply suction lines and has an external return line filter.

How to Remove the Hydraulic Tank

- 1 Place a suitable container under the hydraulic tank. Refer to Section 2, *Specifications*.
- 2 **Before serial number 3364:** Close the two hydraulic tank shut-off valves at the hydraulic tank.

NOTICE Component damage hazard. The engine must not be started with the hydraulic tank shut-off valves in the closed position or component damage will occur. If the tank valves are closed, remove the key from the key switch and tag the machine to inform personnel of the condition.

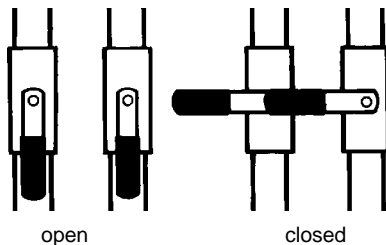

- 3 Remove the drain plug from the hydraulic tank and completely drain the tank into a container of suitable capacity. Refer to Section 2, *Specifications*.

CAUTION Bodily injury hazard. Beware of hot oil. Contact with hot oil may cause severe burns.

- 4 Tag, disconnect and plug the hoses from the return filter. Cap the fittings on the return filter.
- 5 Tag, disconnect and plug the suction hoses from the bottom of the tank. Cap the fittings.
- 6 Remove the fasteners from the hydraulic tank hold down straps. Remove the straps.
- 7 Remove the turntable cover using a suitable lifting device.

WARNING Crushing hazard. The turntable cover could become unbalanced and fall if not properly supported when removed from the machine.

- 8 Support and secure the hydraulic tank to a suitable lifting device. Remove the hydraulic tank from the machine.

WARNING Crushing hazard. The hydraulic tank could become unbalanced and fall if not properly supported and secured to the lifting device when removed from the machine.

Turntable Rotation Components

REV A

12-1

Rotation Hydraulic Motor

The turntable rotation hydraulic motor is the only serviceable component of the turntable rotation assembly. The worm gear may not be removed from the housing. In order to remove the housing, the entire turntable assembly has to be removed.

How to Remove the Turntable Rotation Motor

Note: Do not allow the turntable to rotate until the hydraulic motor is installed.

- 1 Tag, disconnect and plug the hydraulic hoses from the turntable rotation motor. Cap the fittings on the motor.

⚠ WARNING Bodily injury hazard. Spraying hydraulic oil can penetrate and burn skin. Loosen hydraulic connections very slowly to allow the oil pressure to dissipate gradually. Do not allow oil to squirt or spray.

- 2 Remove the turntable rotation motor mounting fasteners. Remove the motor from the worm gear housing.

Axle Components

REV A

13-1 Hub and Bearings, 2WD Models

How to Remove the Hub and Bearings

- 1 Loosen the wheel lug nuts. Do not remove them.
- 2 Block the non-steer wheels and place a lifting jack of ample capacity under the steer axle.
- 3 Raise the machine 6 inches / 15 cm and place blocks under the drive chassis for support.

CAUTION Crushing hazard. The machine may fall if not properly supported.

- 4 Remove the lug nuts. Remove the tire and wheel assembly.
- 5 Remove the dust cap, cotter pin and castle nut.
- 6 Pull the hub off the spindle. The washer and outer bearing should fall loose from the hub.
- 7 Place the hub on a flat surface and gently pry the bearing seal out of the hub. Remove the rear bearing.

How to Install the Hub and Bearings

Note: When replacing a wheel bearing, both the inner and outer bearings, including the pressed-in races, must be replaced.

- 1 Be sure that both bearings are packed with clean, fresh grease.
- 2 Place the large inner bearing into the rear of the hub.
- 3 Install a new bearing grease seal into the hub by pressing it evenly into the hub until it is flush.

Note: Always replace the bearing grease seal when removing the hub.

- 4 Slide the hub onto the yoke spindle.

NOTICE Component damage. Do not apply excessive force or damage to the lip of the seal may occur.

- 5 Fill the hub cavity with clean, fresh grease.
- 6 Place the outer bearing into the hub.
- 7 Install the washer and castle nut.
- 8 Tighten the castle nut to 158 ft-lbs / 214 Nm to seat the bearings.

Note: Rotate the hub by hand while torquing the castle nut to make sure the bearings seat properly.

- 9 Loosen the castle nut one full turn and then torque to 35 ft-lbs / 47 Nm.
- 10 Install a new cotter pin. Bend the cotter pin to lock it in.

Note: Always use a new cotter pin when installing a castle nut.

- 11 Install the dust cap, then the tire and wheel assembly. Torque the wheel lug nuts to specification. Refer to Section 2, *Specifications*.

Schematics



Observe and Obey:

- ☑ Troubleshooting and repair procedures shall be completed by a person trained and qualified on the repair of this machine.
- ☑ Immediately tag and remove from service a damaged or malfunctioning machine.
- ☑ Repair any machine damage or malfunction before operating the machine.

Before Troubleshooting:

- ☑ Read, understand and obey the safety rules and operating instructions printed in the appropriate *Genie Z-34/22 IC Operator's Manual* on your machine.
- ☑ Be sure that all necessary tools and test equipment are available and ready for use.

About This Section

There are two groups of schematics in this section. An illustration legend precedes each group of drawings.

Electrical Schematics

▲WARNING Electrocution hazard. Contact with electrically charged circuits could result in death or serious injury. Remove all rings, watches and other jewelry.

Hydraulic Schematics

▲WARNING Bodily injury hazard. Spraying hydraulic oil can penetrate and burn skin. Loosen hydraulic connections very slowly to allow the oil pressure to dissipate gradually. Do not allow oil to squirt or spray.

General Repair Process

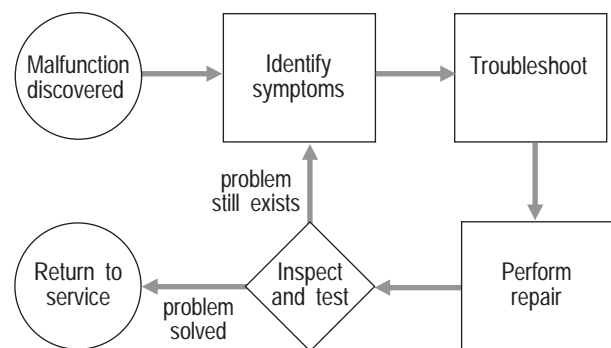

Electrical Symbols Legend

REV A

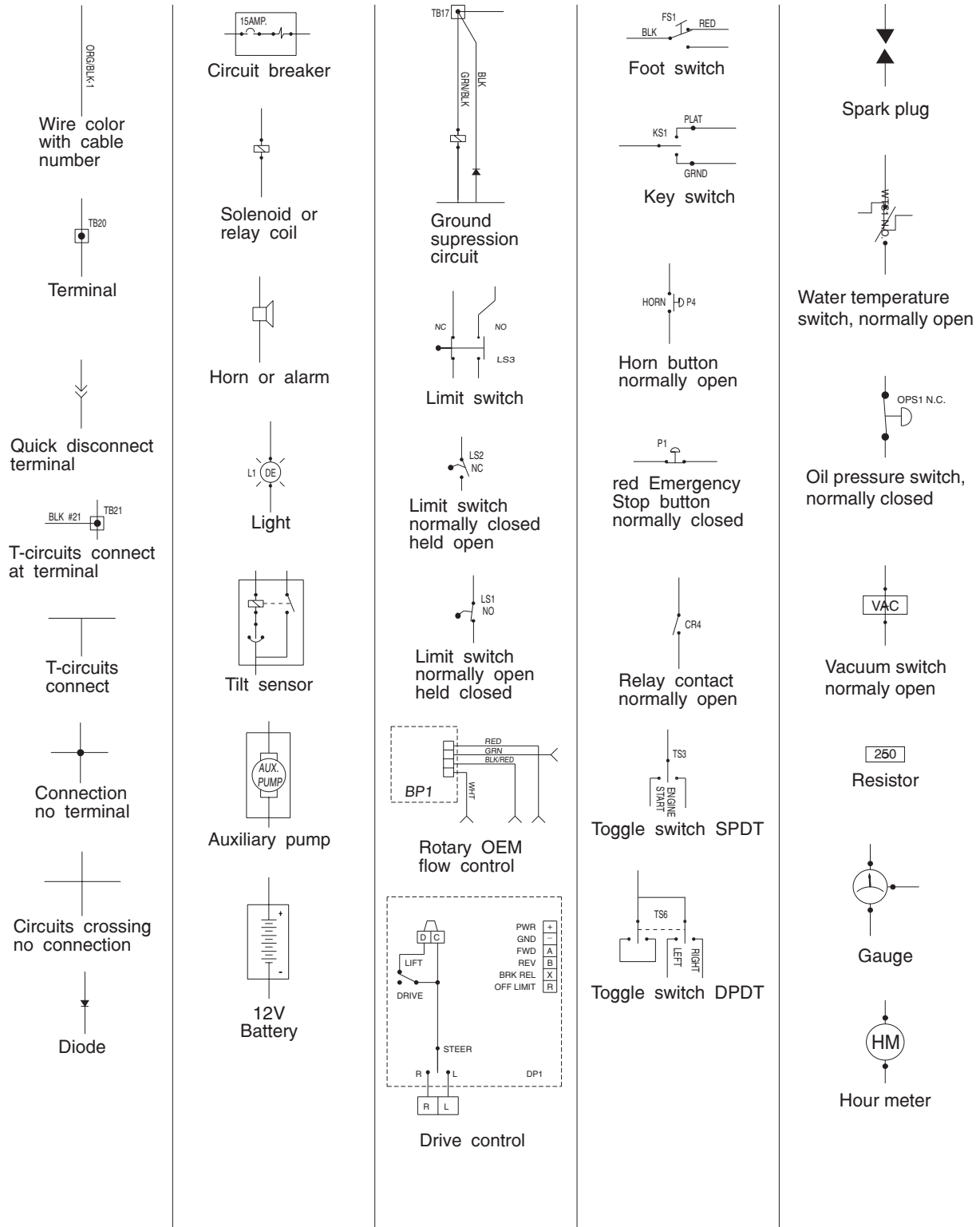

Hydraulic Symbols Legend

REV A

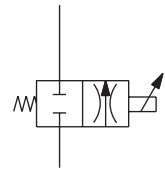
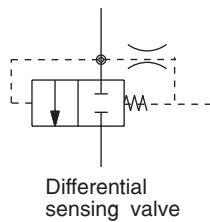
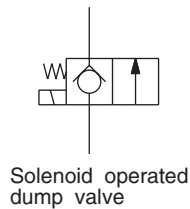
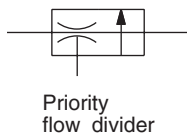
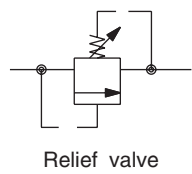
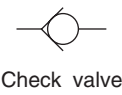
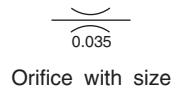
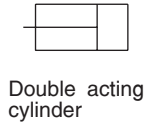
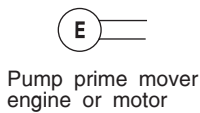
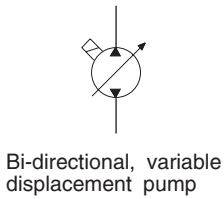
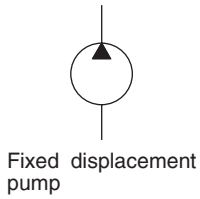
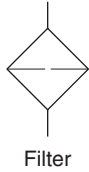

Solenoid operated proportional valve

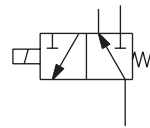

Solenoid operated 2 pos., 3 way, directional valve

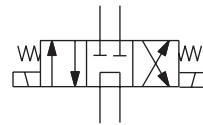

Solenoid operated 3 pos., 4 way, directional valve (D01)

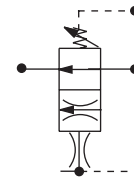

Pilot operated flow control valve

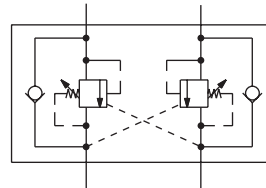

Counterbalance valve

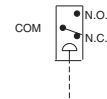

Pressure switch



Brake



Variable orifice or shut off valve

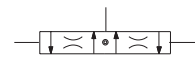

Flow divider combiner

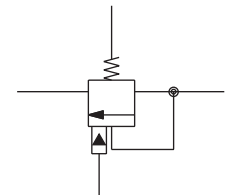

Sequencing valve

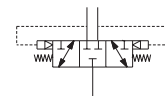

Shuttle valve

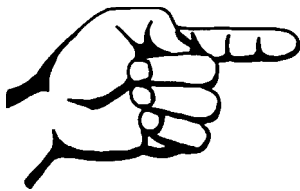

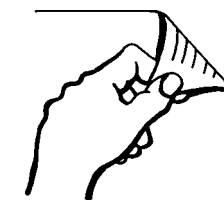
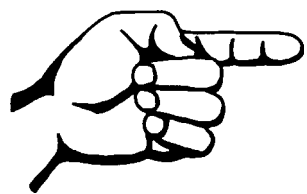

Electrical Schematic - Diesel Models (from serial number 3242 to 3577)

REV A

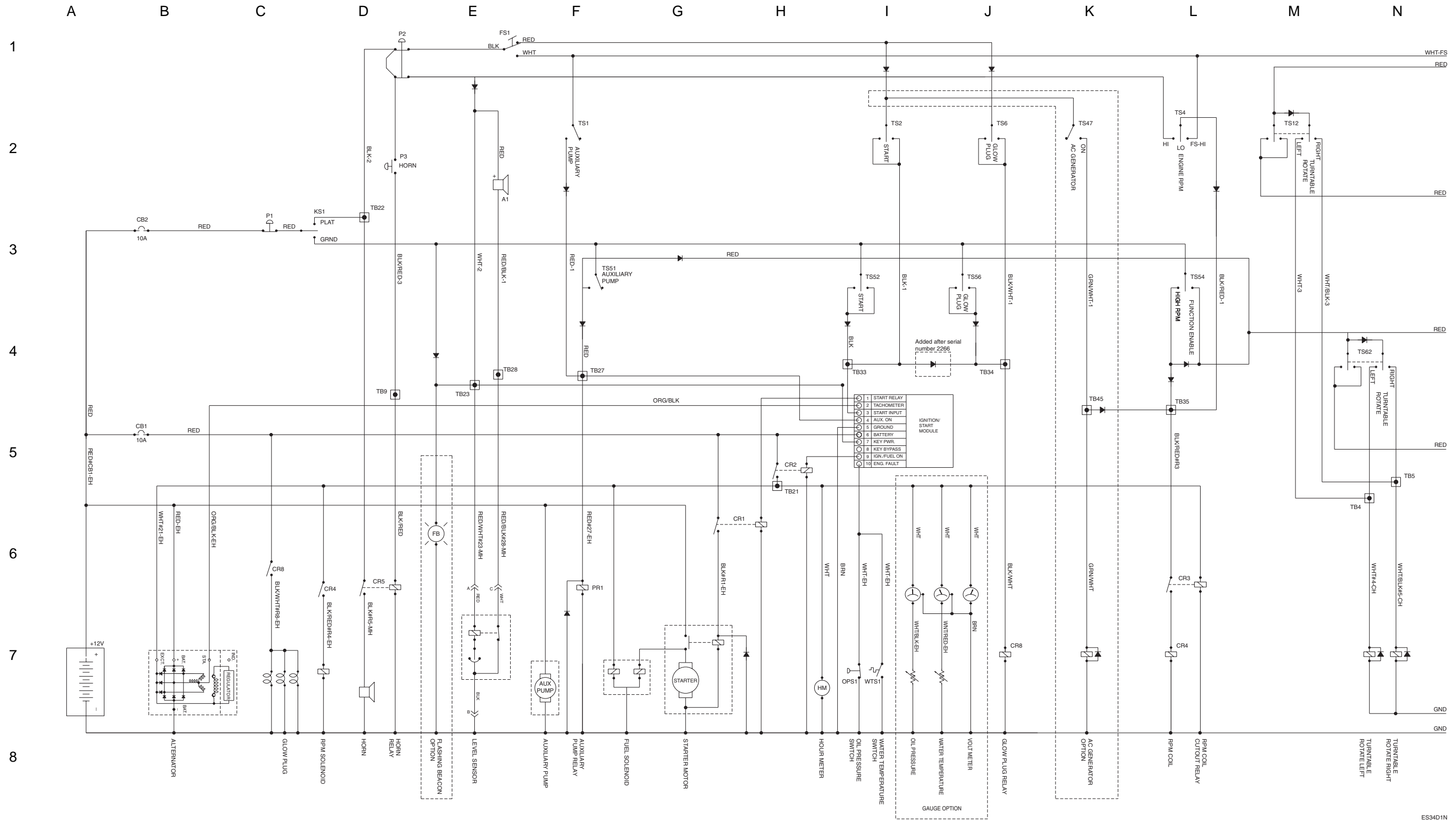

ES34D1N

Electrical Schematic - Diesel Models (from serial number 3242 to 3577)

REV A

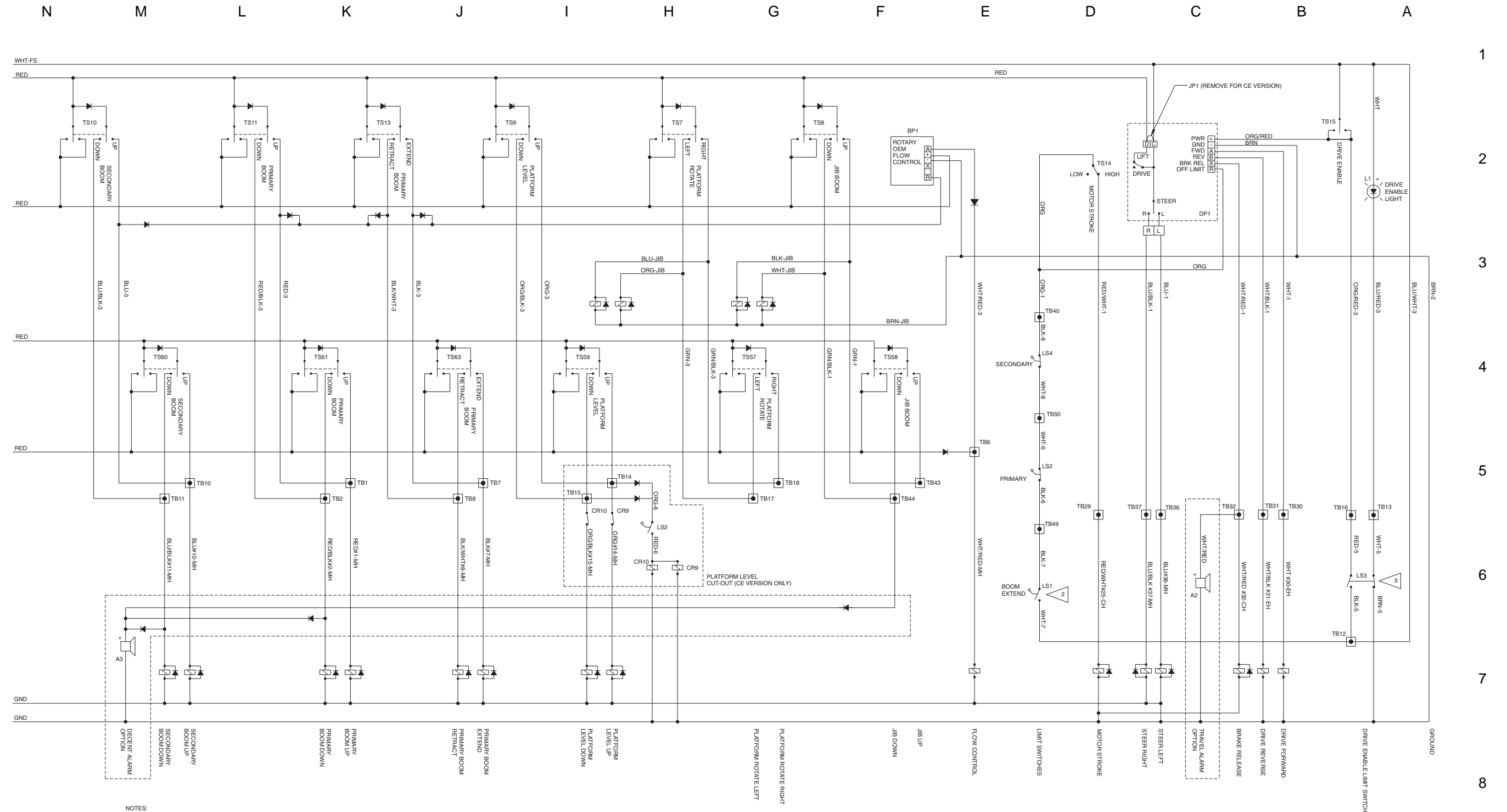

- NOTES:
1. ALL LIMIT SWITCHES SHOWN WITH BOOM IN STOWED POSITION EXCEPT AS NOTED.
 2. SWITCH SHOWN WITH BOOM EXTENDED.
 3. SWITCH SHOWN WITH BOOM ROTATED PAST EITHER NON-STEER WHEEL.

**Electrical Schematic - Diesel Models
(from serial number 3242 to 3577)**

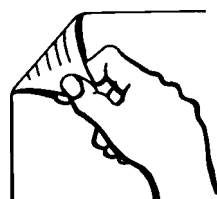

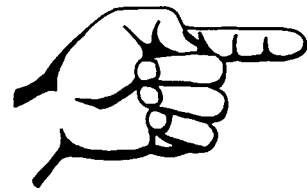

Electrical Schematic - Diesel Models (from serial number 3578 to 4799)

REV A

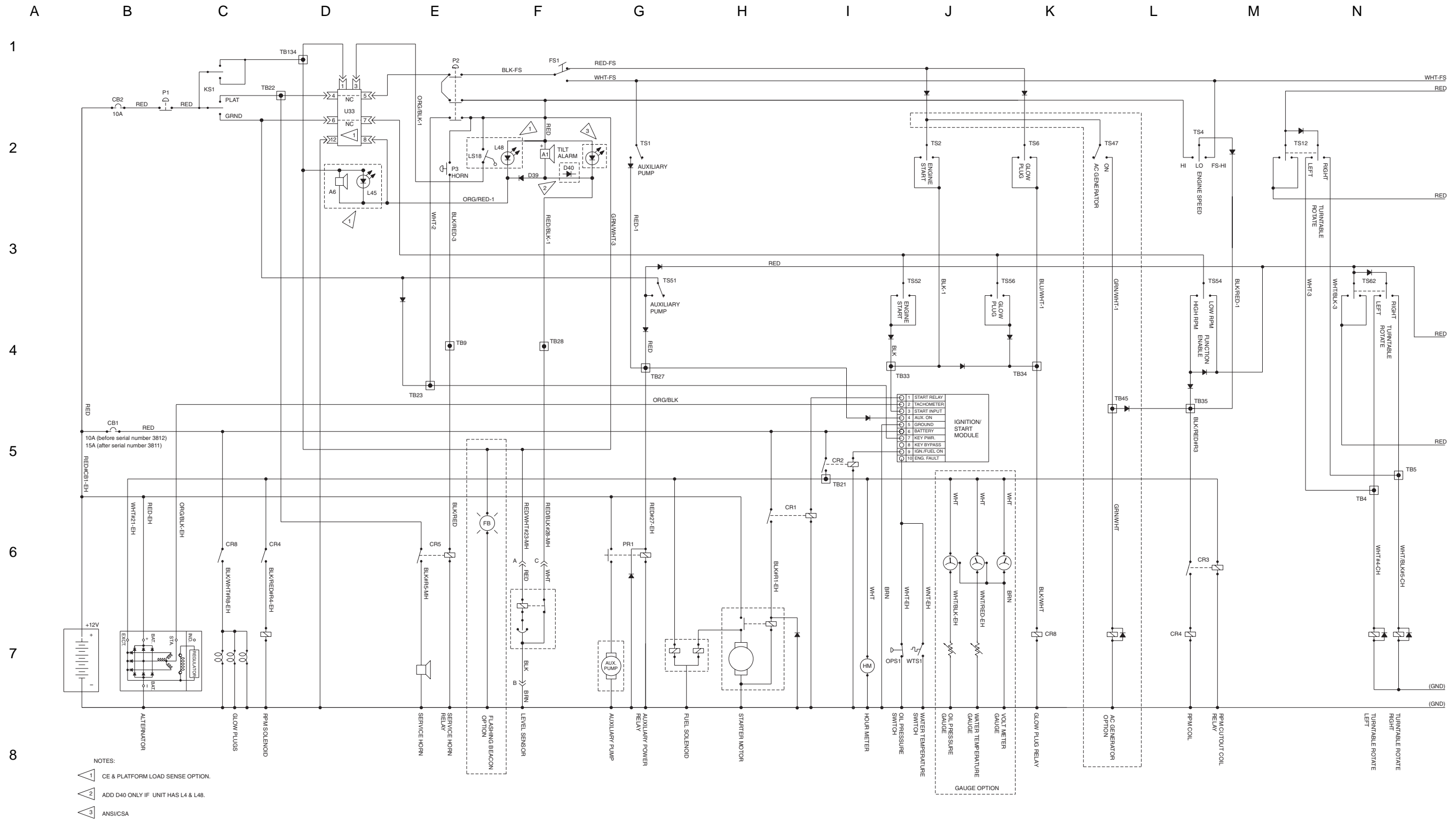

Electrical Schematic - Diesel Models (from serial number 3578 to 4799)

REV A

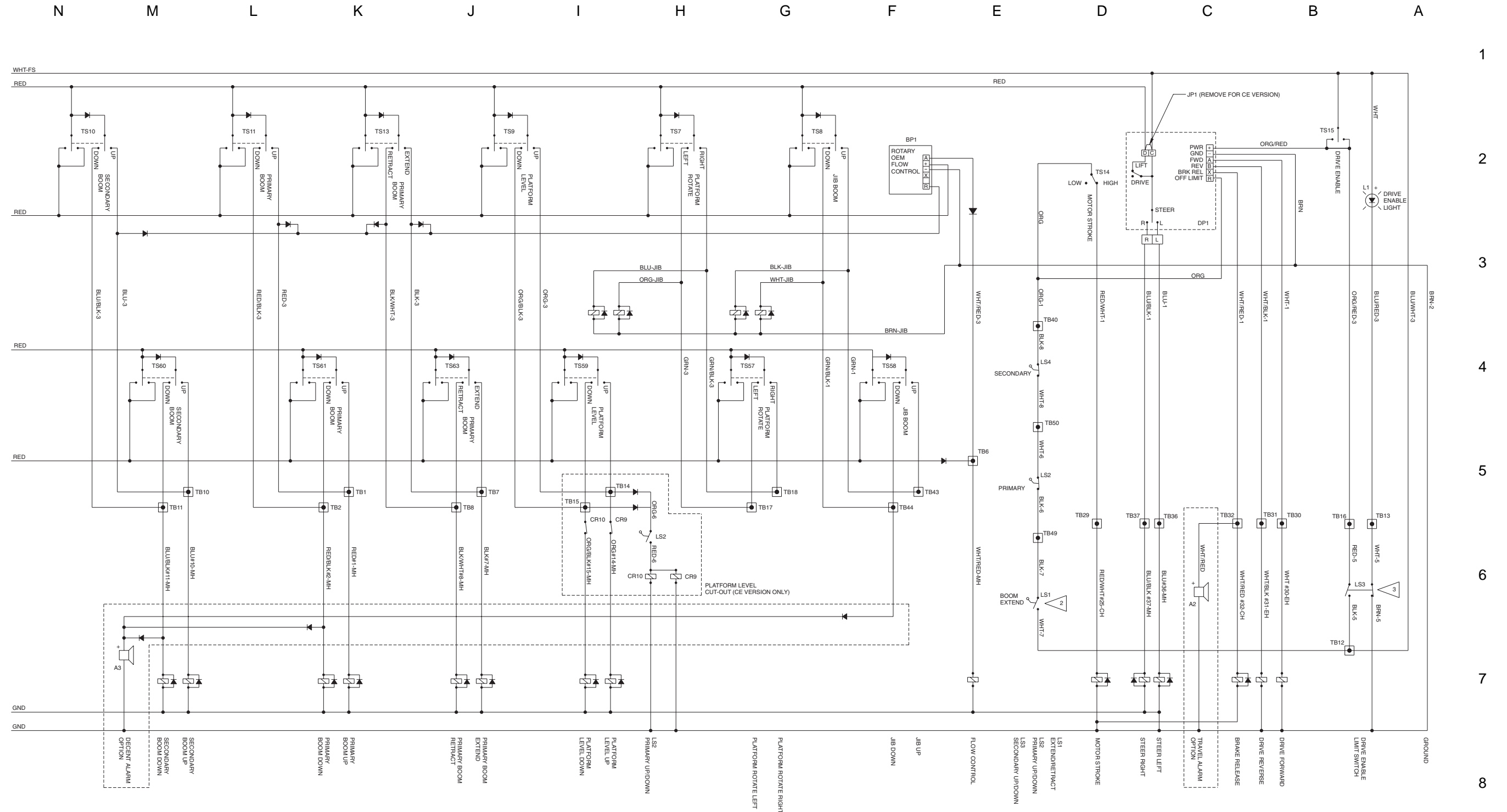

- NOTES:
1. ALL LIMIT SWITCHES SHOWN WITH BOOM IN STOWED POSITION EXCEPT AS NOTED.
 2. SWITCH SHOWN WITH BOOM EXTENDED.
 3. SWITCH SHOWN WITH BOOM ROTATED PAST EITHER NON-STEER WHEEL.

**Electrical Schematic - Diesel Models
(from serial number 3578 to 4799)**

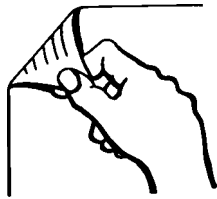

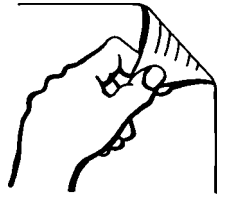
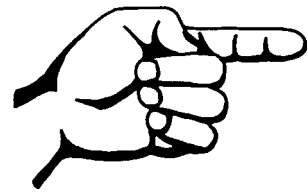

Electrical Schematic - Gasoline/LPG Models (from serial number 3242 to 3577)

REV A

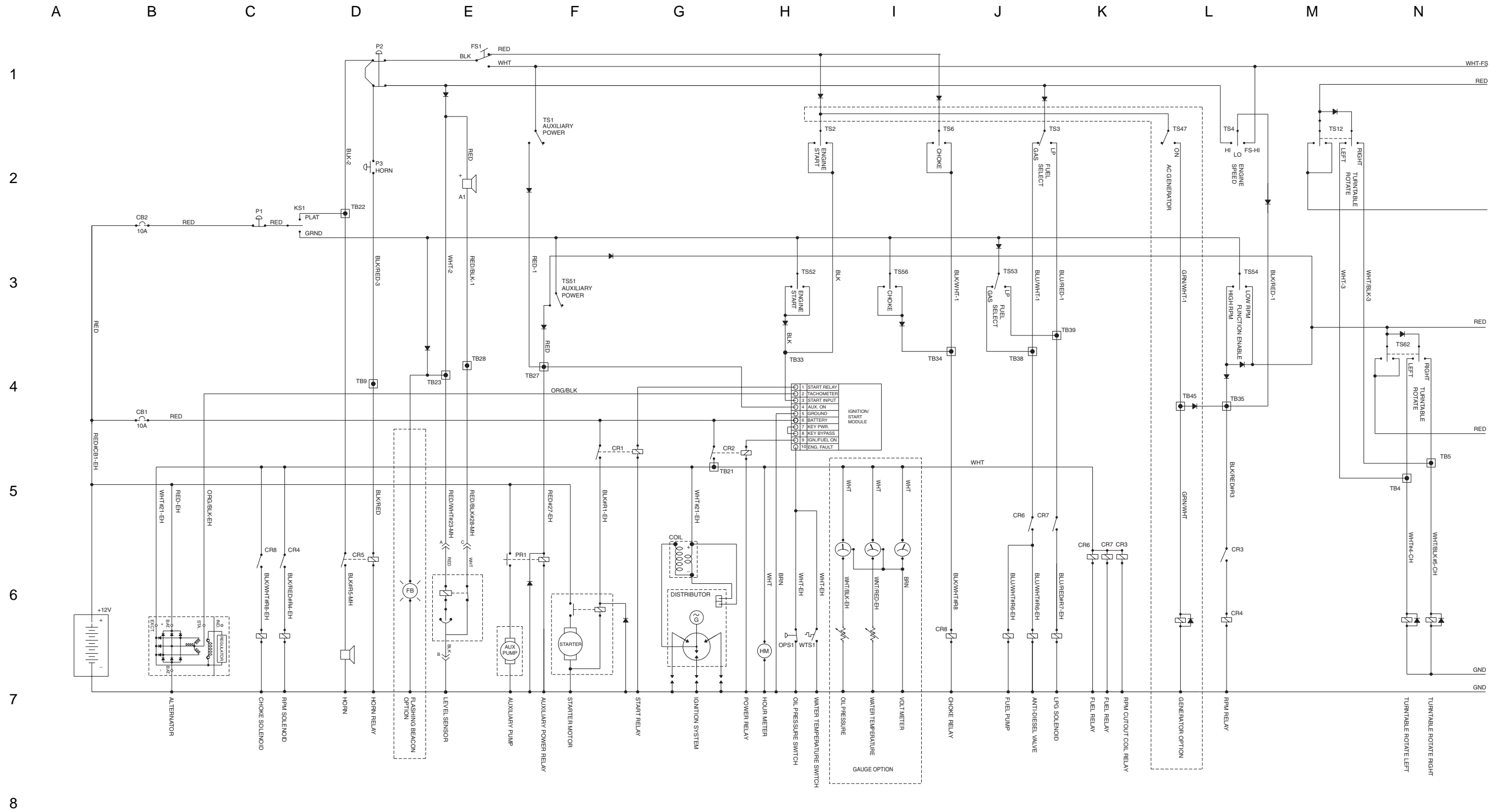

Electrical Schematic - Gasoline/LPG Models (from serial number 3242 to 3577)

REV A

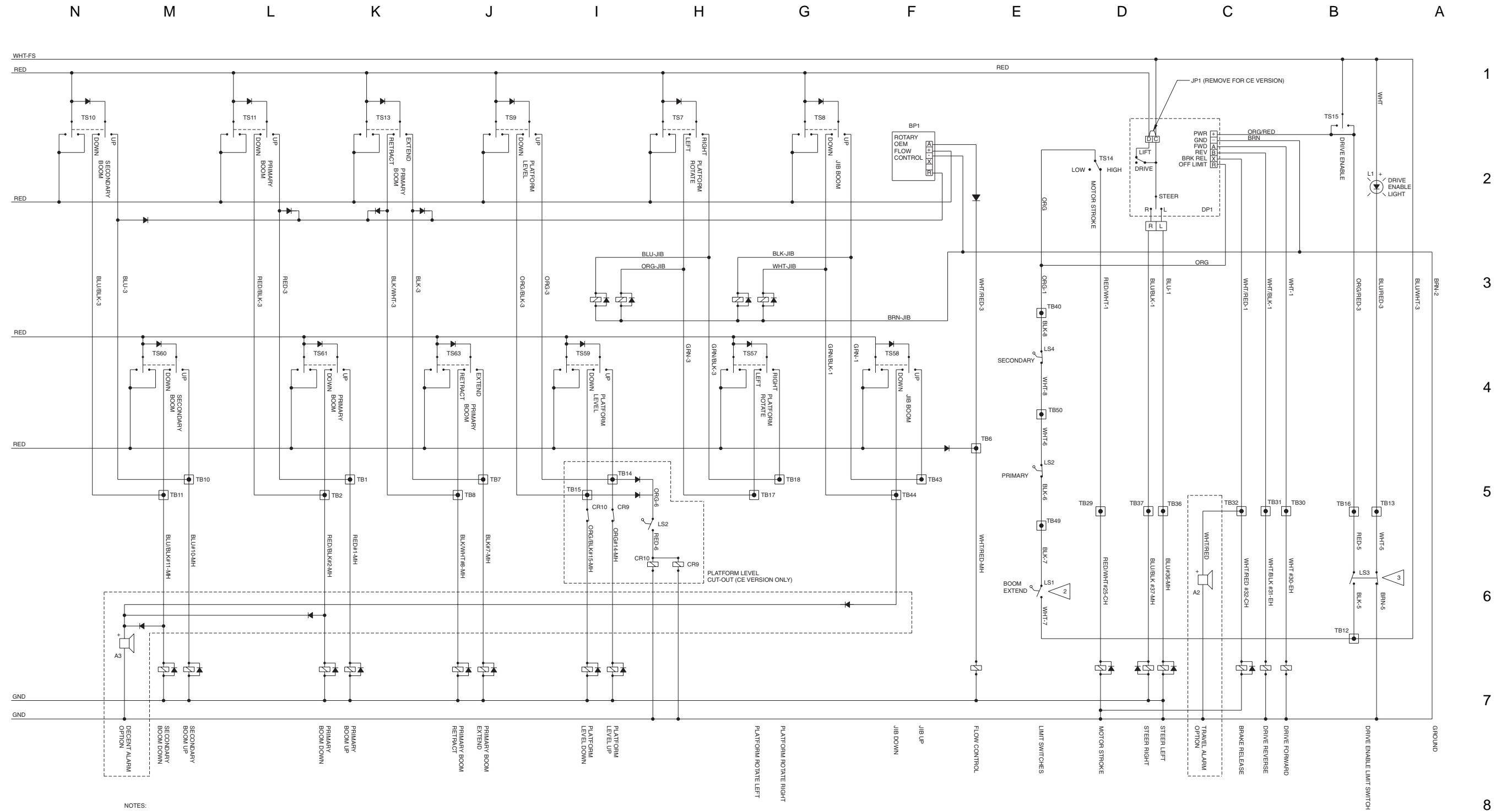

- NOTES:
- 1. ALL LIMIT SWITCHES SHOWN WITH BOOM IN STOWED POSITION EXCEPT AS NOTED.
 - 2. SWITCH SHOWN WITH BOOM EXTENDED.
 - 3. SWITCH SHOWN WITH BOOM ROTATED PAST EITHER NON-STEER WHEEL.

**Electrical Schematic - Gasoline/LPG Models
(from serial number 3242 to 3577)**

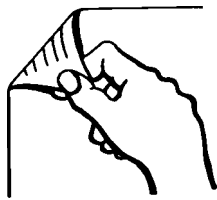

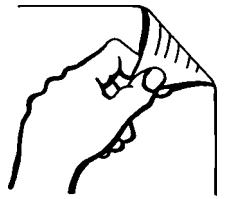
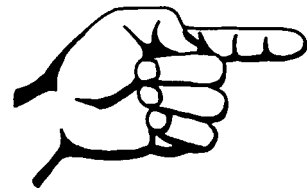

Electrical Schematic - Gasoline/LPG Models (from serial number 3578 to 4799)

REV A

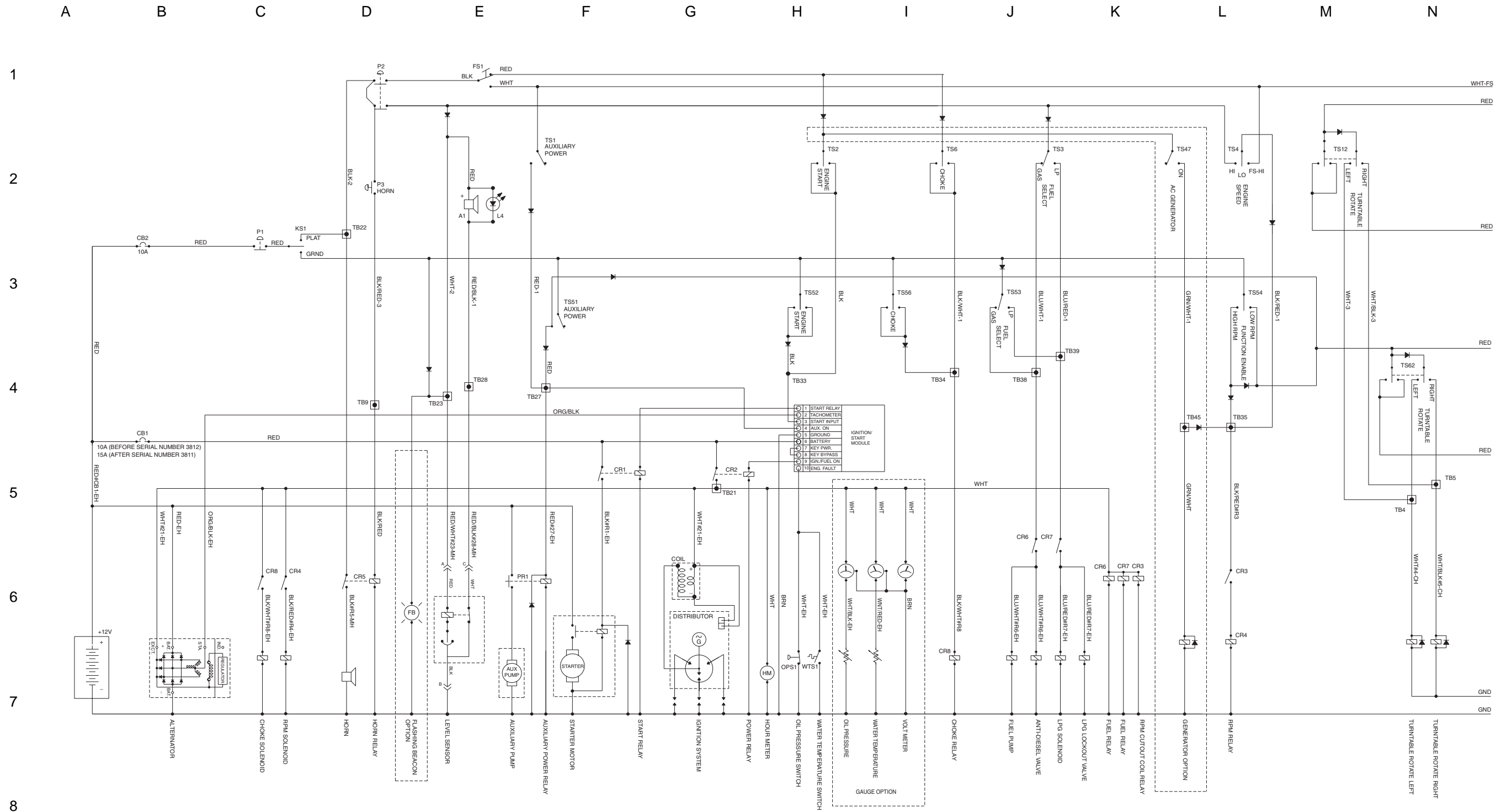

Electrical Schematic - Gasoline/LPG Models (from serial number 3578 to 4799)

REV A

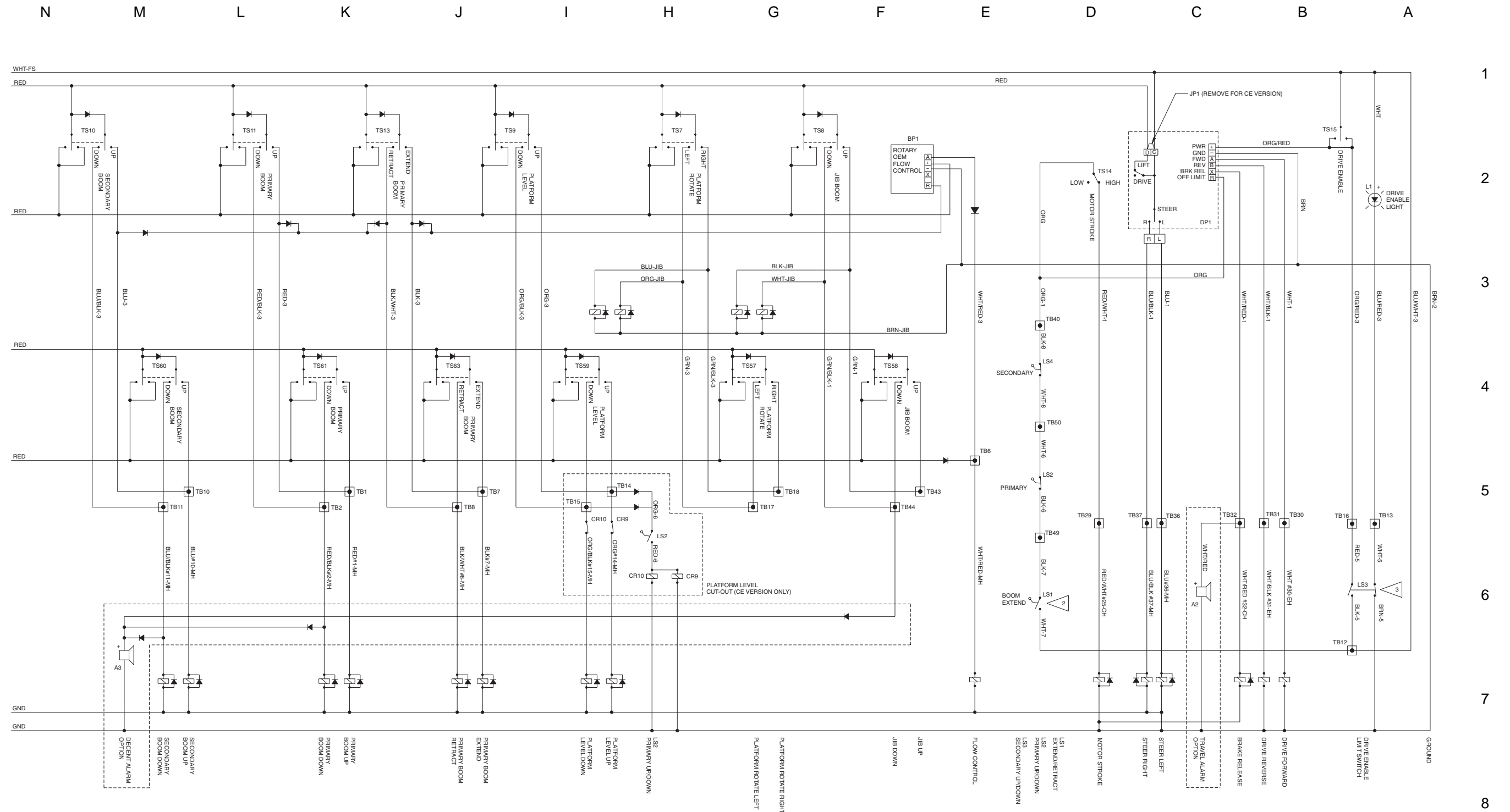

- NOTES:
1. ALL LIMIT SWITCHES SHOWN WITH BOOM IN STOWED POSITION EXCEPT AS NOTED.
 2. SWITCH SHOWN WITH BOOM EXTENDED.
 3. SWITCH SHOWN WITH BOOM ROTATED PAST EITHER NON-STEER WHEEL.

**Electrical Schematic - Gasoline/LPG Models
(from serial number 3578 to 4799)**

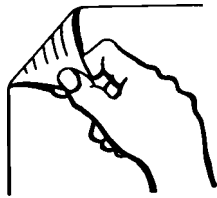

**Ground Control Box Wiring Diagram - Diesel Models
(from serial number 3242 to 3308)**

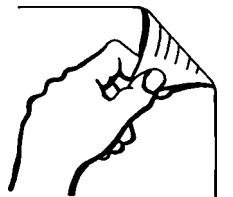
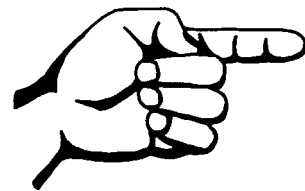

Ground Control Box Wiring Diagram - Diesel Models (from serial number 3242 to 3308)

REV A

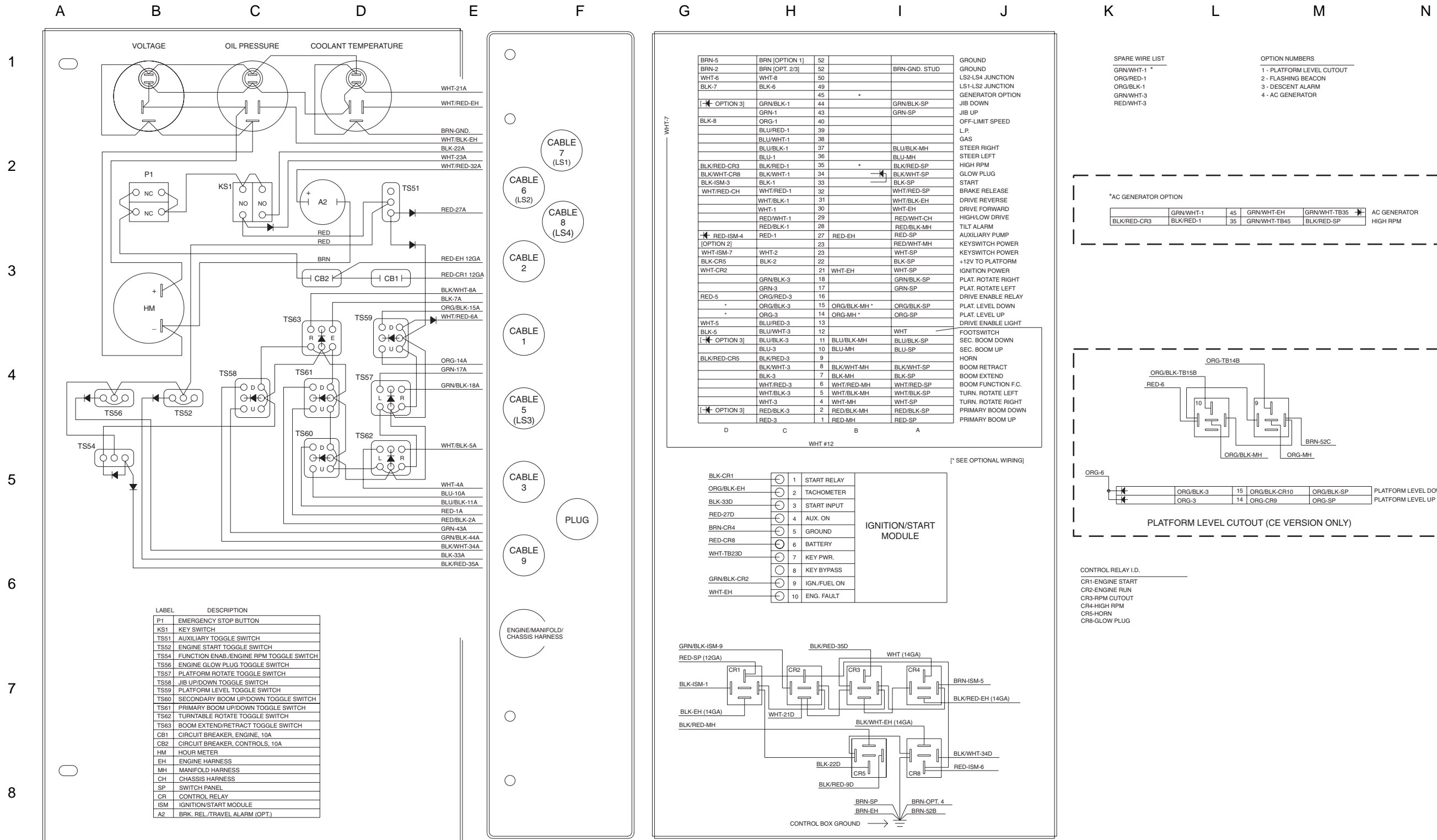

Ground Control Box Wiring Diagram - Diesel Models (from serial number 3309 to 3577)

REV A

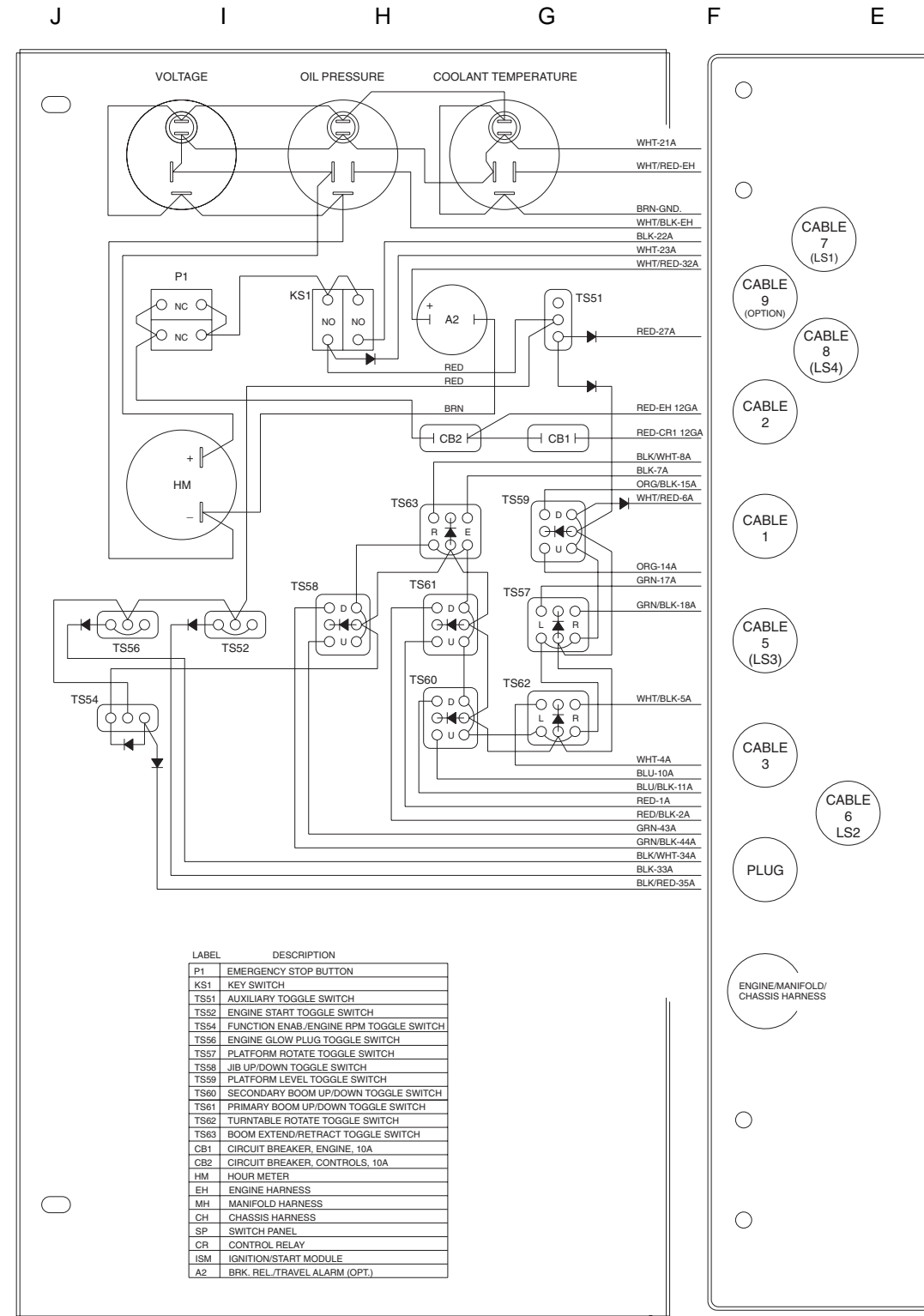
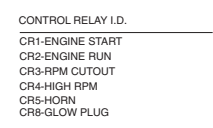
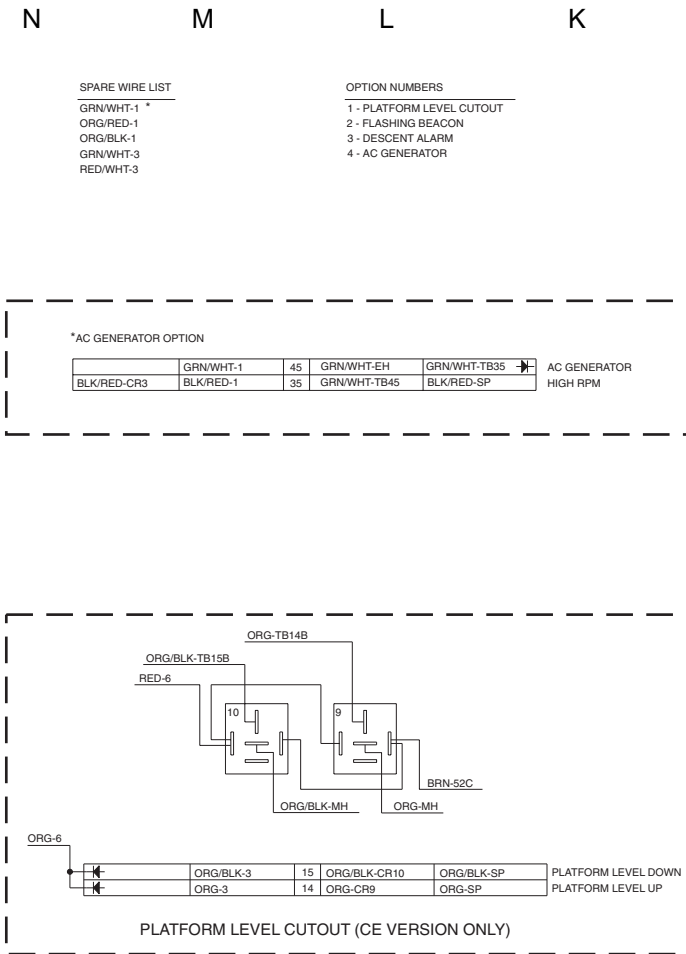

LABEL	DESCRIPTION
P1	EMERGENCY STOP BUTTON
KS1	KEY SWITCH
TS51	AUXILIARY TOGGLE SWITCH
TS52	ENGINE START TOGGLE SWITCH
TS54	FUNCTION ENAB./ENGINE RPM TOGGLE SWITCH
TS56	ENGINE GLOW PLUG TOGGLE SWITCH
TS57	PLATFORM ROTATE TOGGLE SWITCH
TS58	JIB UP/DOWN TOGGLE SWITCH
TS59	PLATFORM LEVEL TOGGLE SWITCH
TS60	SECONDARY BOOM UP/DOWN TOGGLE SWITCH
TS61	PRIMARY BOOM UP/DOWN TOGGLE SWITCH
TS62	TURNTABLE ROTATE TOGGLE SWITCH
TS63	BOOM EXTEND/RETRACT TOGGLE SWITCH
CB1	CIRCUIT BREAKER, ENGINE, 10A
CB2	CIRCUIT BREAKER, CONTROLS, 10A
HM	HOUR METER
EH	ENGINE HARNESS
MH	MANIFOLD HARNESS
CH	CHASSIS HARNESS
SP	SWITCH PANEL
CR	CONTROL RELAY
ISM	IGNITION/START MODULE
A2	BRK. REL./TRAVEL ALARM (OPT.)

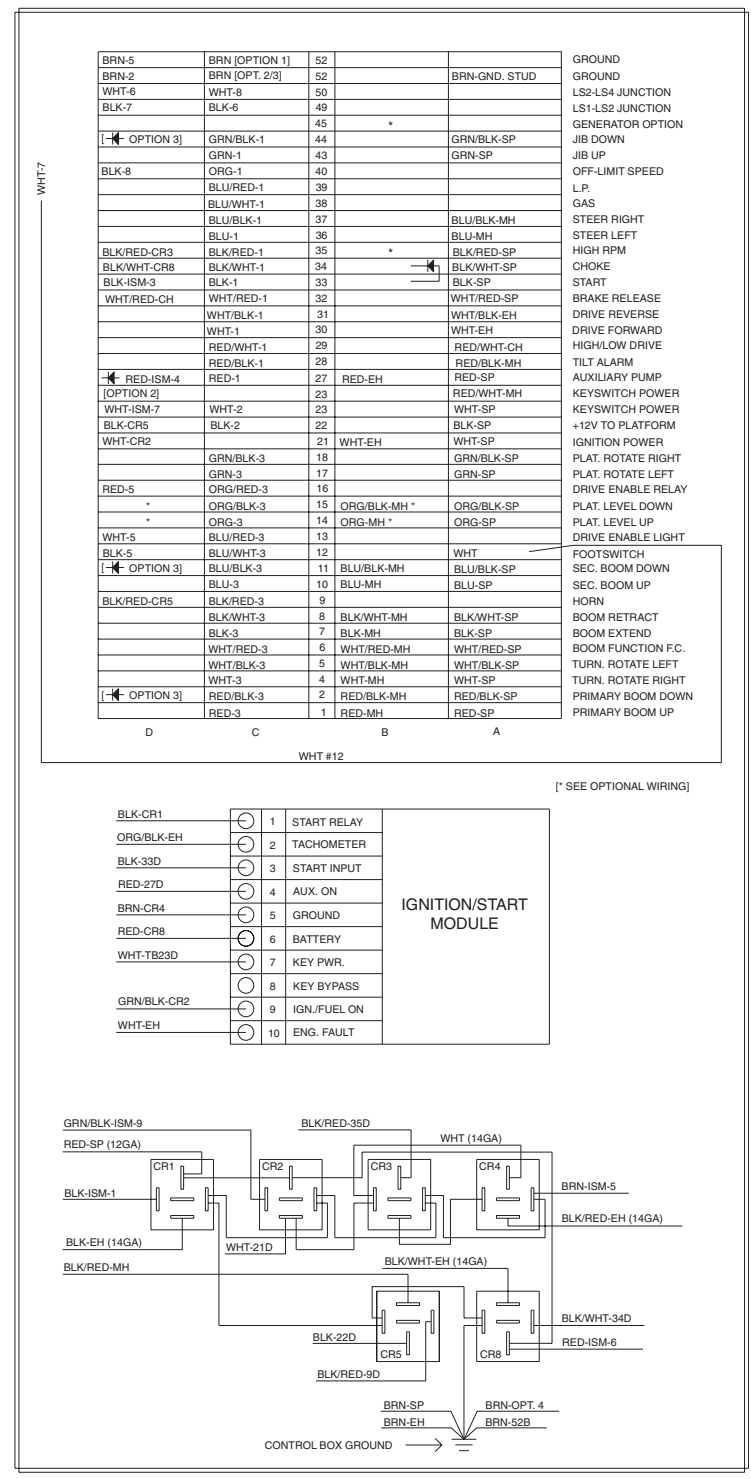

ES3405N

**Ground Control Box Wiring Diagram - Diesel Models
(from serial number 3309 to 3577)**

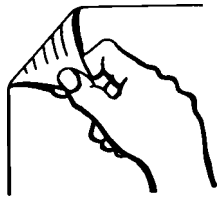

**Ground Control Box Wiring Diagram - Diesel Models
(from serial number 3578 to 4799)**

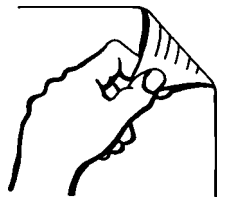
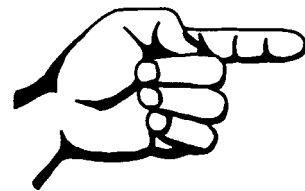

Ground Control Box Wiring Diagram - Diesel Models (from serial number 3578 to 4799)

REV A

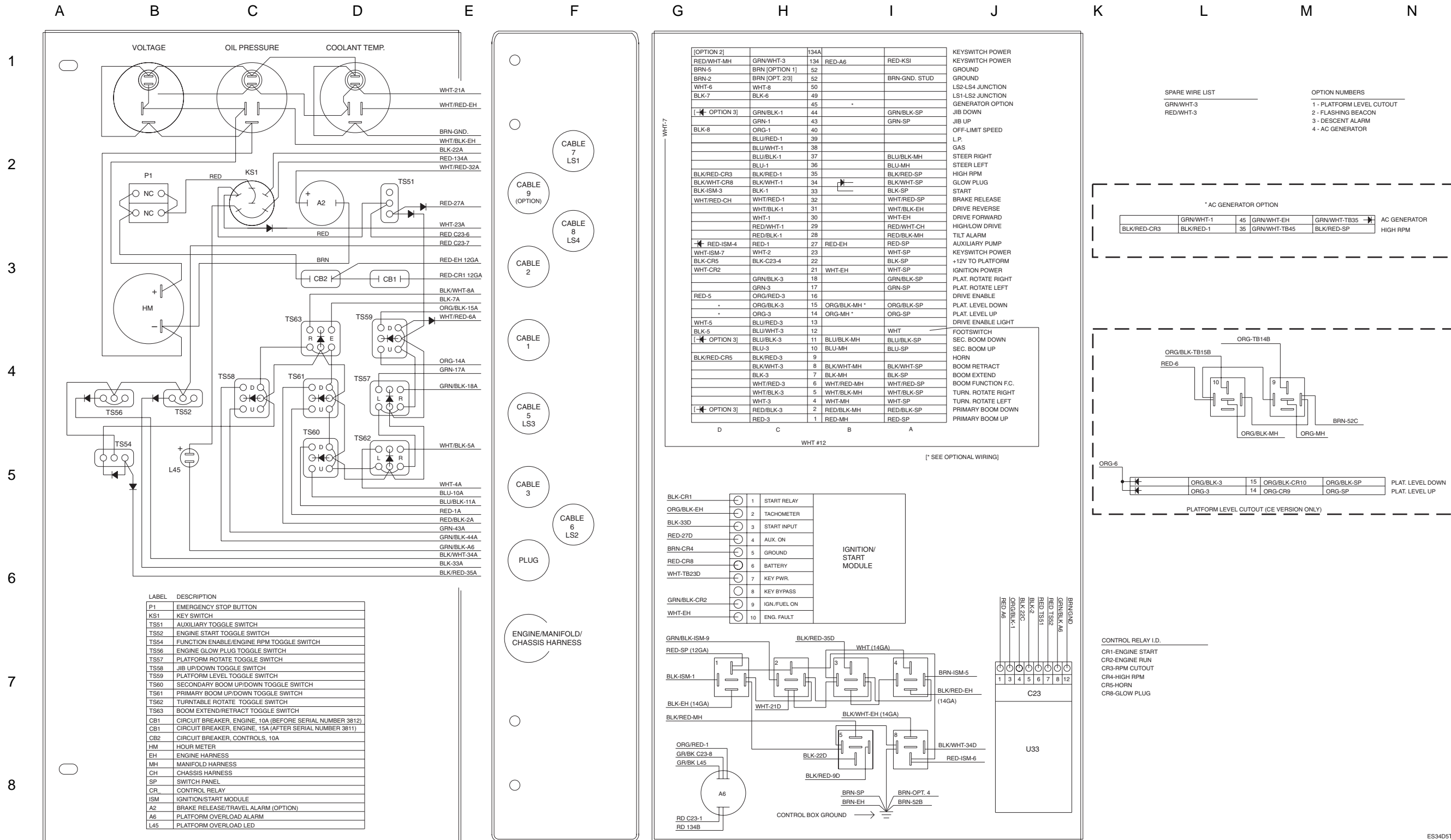

Ground Control Box Wiring Diagram - Gasoline/LPG Models (from serial number 3242 to 3308)

REV A

N M L K J I H G F E D C B A

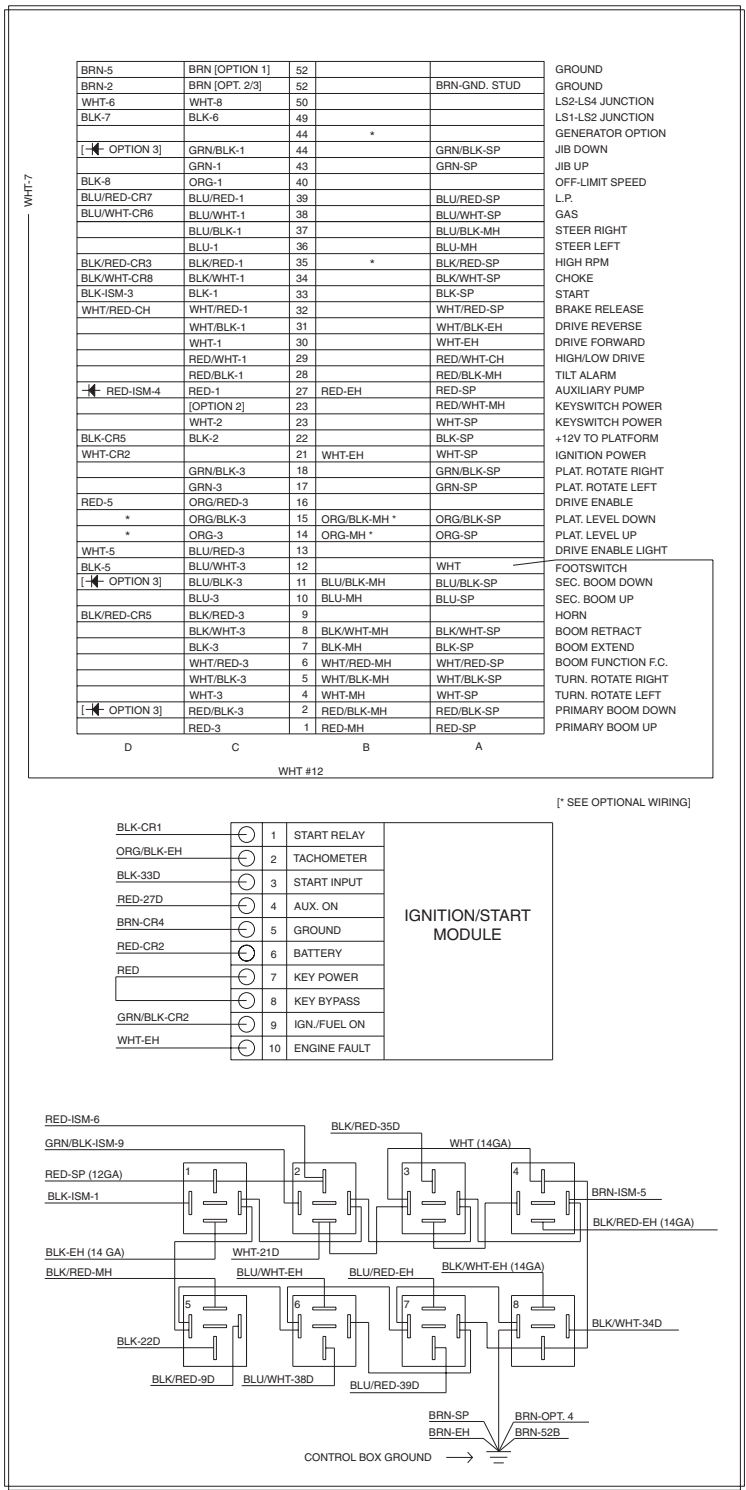
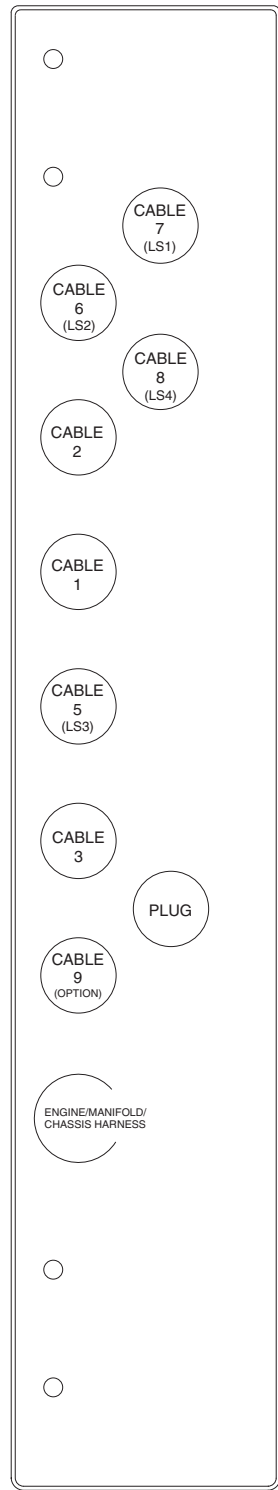
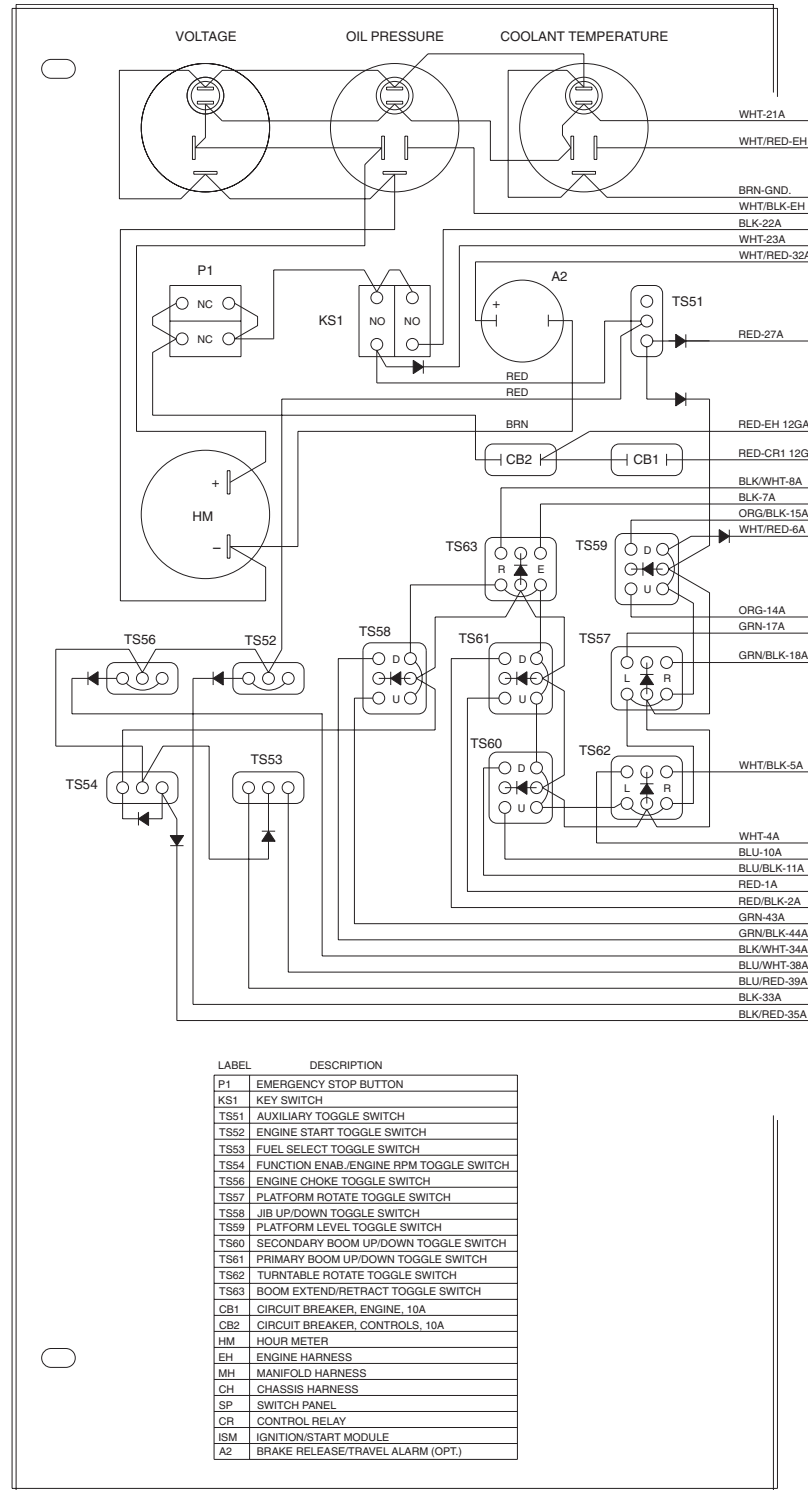
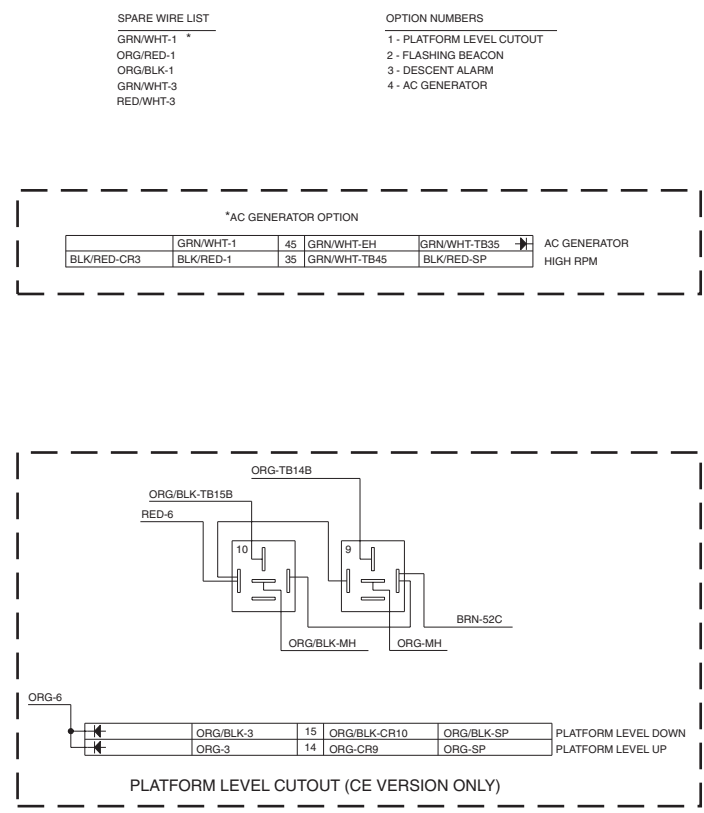

CONTROL RELAY I.D.

- CR1-ENGINE START
- CR2-ENGINE RUN
- CR3-RPM CUTOUT
- CR4-HIGH RPM
- CR5-HORN
- CR6-FUEL PUMP (GAS)
- CR7-LPG SOLENOID
- CR8-CHOKE

ES34GFSM

**Ground Control Box Wiring Diagram -
Gasoline/LPG Models
(from serial number 3242 to 3308)**

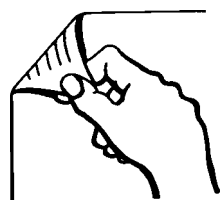

**Ground Control Box Wiring Diagram -
Gasoline/LPG Models
(from serial number 3309 to 3577)**

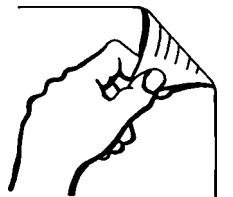
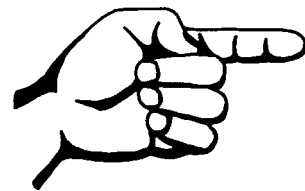

Ground Control Box Wiring Diagram - Gasoline/LPG Models (from serial number 3309 to 3577)

REV A

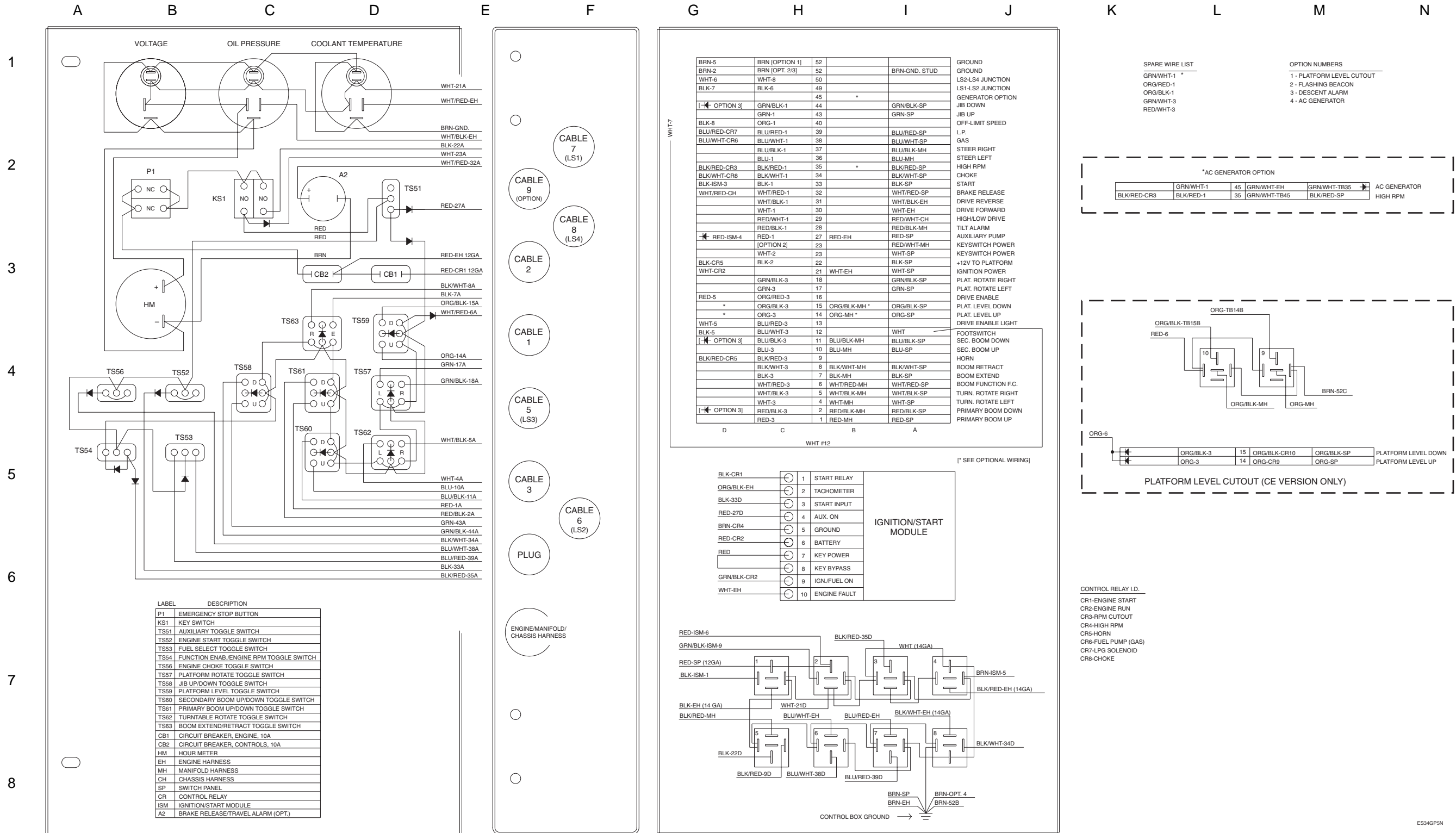

Ground Control Box Wiring Diagram - Gasoline/LPG Models (from serial number 3578 to 4799)

REV A

N M L K J I H G F E D C B A

SPARE WIRE LIST

GRN/WHT-1 *
ORG/RED-1
ORG/BLK-1
GRN/WHT-3
RED/WHT-3

OPTION NUMBERS

1 - PLATFORM LEVEL CUTOUT
2 - FLASHING BEACON
3 - DESCENT ALARM
4 - AC GENERATOR

*** AC GENERATOR OPTION**

GRN/WHT-1	45	GRN/WHT-EH	GRN/WHT-TB35	AC GENERATOR
BLK/RED-CR3	35	GRN/WHT-TB45	BLK/RED-SP	HIGH RPM

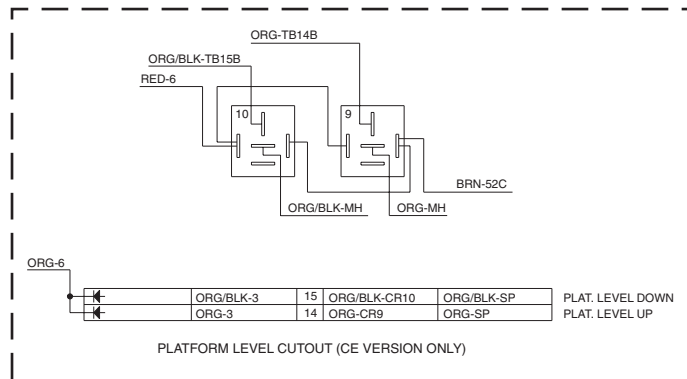

CONTROL RELAY I.D.

CR1-ENGINE START
CR2-ENGINE RUN
CR3-RPM CUTOUT
CR4-HIGH RPM
CR5-HORN
CR6-FUEL PUMP (GAS)
CR7-LPG SOLENOID
CR8-CHOKE

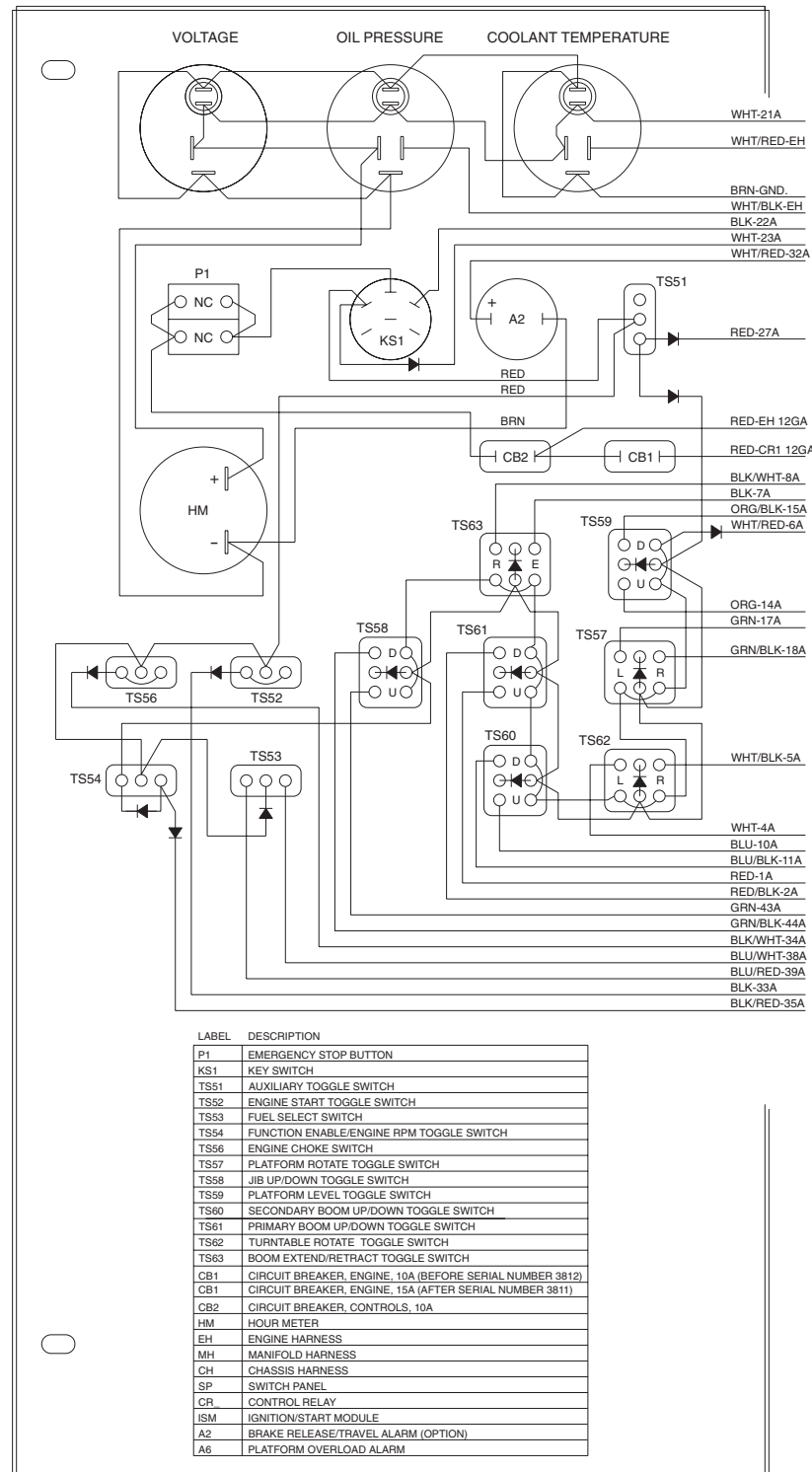

LABEL	DESCRIPTION
P1	EMERGENCY STOP BUTTON
KS1	KEY SWITCH
TS51	AUXILIARY TOGGLE SWITCH
TS52	ENGINE START TOGGLE SWITCH
TS53	FUEL SELECT SWITCH
TS54	FUNCTION ENABLE/ENGINE RPM TOGGLE SWITCH
TS56	ENGINE CHOKE SWITCH
TS57	PLATFORM ROTATE TOGGLE SWITCH
TS58	JIB UP/DOWN TOGGLE SWITCH
TS59	PLATFORM LEVEL TOGGLE SWITCH
TS60	SECONDARY BOOM UP/DOWN TOGGLE SWITCH
TS61	PRIMARY BOOM UP/DOWN TOGGLE SWITCH
TS62	TURNTABLE ROTATE TOGGLE SWITCH
TS63	BOOM EXTEND/RETRACT TOGGLE SWITCH
CB1	CIRCUIT BREAKER, ENGINE, 10A (BEFORE SERIAL NUMBER 3812)
CB1	CIRCUIT BREAKER, ENGINE, 15A (AFTER SERIAL NUMBER 3811)
CB2	CIRCUIT BREAKER, CONTROLS, 10A
HM	HOUR METER
EH	ENGINE HARNESS
MH	MANIFOLD HARNESS
CH	CHASSIS HARNESS
SP	SWITCH PANEL
CR	CONTROL RELAY
ISM	IGNITION/START MODULE
A2	BRAKE RELEASE/TRAVEL ALARM (OPTION)
A6	PLATFORM OVERLOAD ALARM

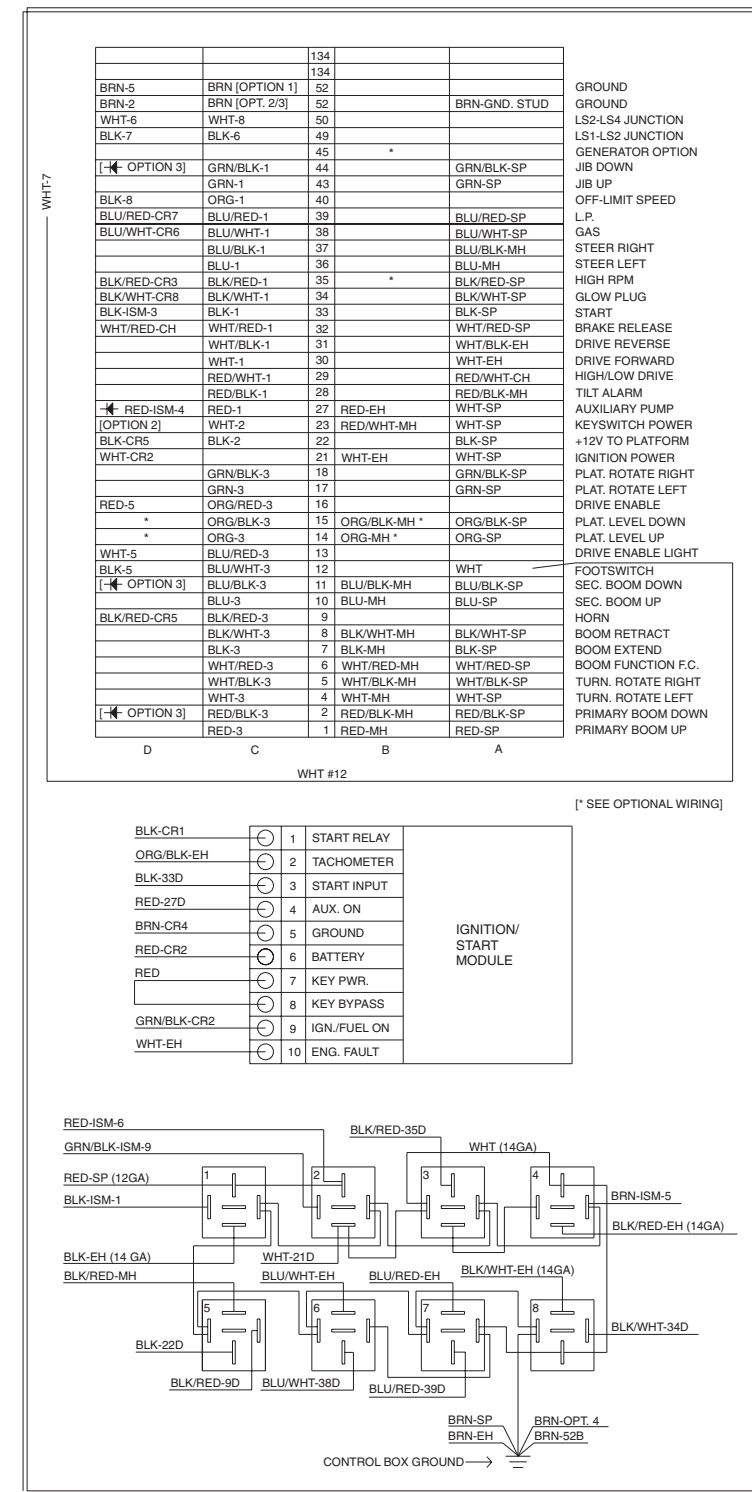

WHT #12	D	C	B	A
BRN-5	BRN (OPTION 1)	52		
BRN-2	BRN (OPT. 2/3)	52		BRN-GND. STUD
WHT-6	WHT-8	50		
BLK-7	BLK-6	49		
		45	*	
[] OPTION 3	GRN/BLK-1	44		GRN/BLK-SP
	GRN-1	43		GRN-SP
BLK-8	ORG-1	40		
BLU/RED-CR7	BLU/RED-1	39		BLU/RED-SP
BLU/WHT-CR6	BLU/WHT-1	38		BLU/WHT-SP
	BLU/BLK-1	37		BLU/BLK-MH
	BLU-1	36		BLU-MH
BLK/RED-CR3	BLK/RED-1	35	*	BLK/RED-SP
BLK/WHT-CR8	BLK/WHT-1	34		BLK/WHT-SP
BLK-ISM-3	BLK-1	33		BLK-SP
WHT/RED-CH	WHT/RED-1	32		WHT/RED-SP
	WHT/BLK-1	31		WHT/BLK-EH
	WHT-1	30		WHT-EH
	RED/WHT-1	29		RED/WHT-CH
	RED/BLK-1	28		RED/BLK-MH
[] OPTION 3	RED-1	27	RED-EH	WHT-SP
[] OPTION 2	WHT-2	23	RED/WHT-MH	WHT-SP
BLK-CR5	BLK-2	22		BLK-SP
WHT-CR2		21	WHT-EH	WHT-SP
	GRN/BLK-3	18		GRN/BLK-SP
	GRN-3	17		GRN-SP
RED-5	ORG/RED-3	16		
*	ORG/BLK-3	15	ORG/BLK-MH *	ORG/BLK-SP
	ORG-3	14	ORG-MH *	ORG-SP
WHT-5	BLU/RED-3	13		
BLK-5	BLU/WHT-3	12		WHT
[] OPTION 3	BLU/BLK-3	11	BLU/BLK-MH	BLU/BLK-SP
	BLU-3	10	BLU-MH	BLU-SP
BLK/RED-CR5	BLK/RED-3	9		
	BLK/WHT-3	8	BLK/WHT-MH	BLK/WHT-SP
	BLK-3	7	BLK-MH	BLK-SP
	WHT/RED-3	6	WHT/RED-MH	WHT/RED-SP
	WHT/BLK-3	5	WHT/BLK-MH	WHT/BLK-SP
	WHT-3	4	WHT-MH	WHT-SP
[] OPTION 3	RED/BLK-3	2	RED/BLK-MH	RED/BLK-SP
	RED-3	1	RED-MH	RED-SP

(* SEE OPTIONAL WIRING)

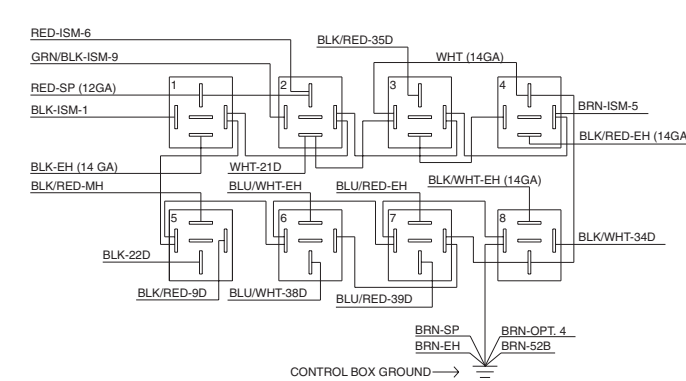
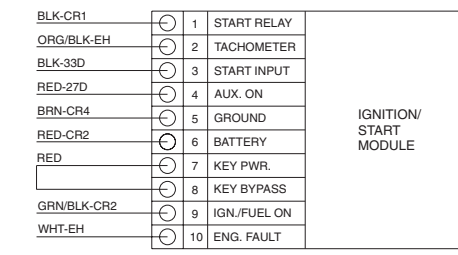

ES34GP4U

**Ground Control Box Wiring Diagram -
Gasoline/LPG Models
(from serial number 3578 to 4799)**

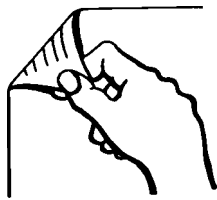

**Platform Control Box Wiring Diagram - Diesel Models
(from serial number 3242 to 3577)**

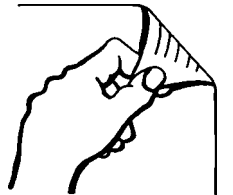
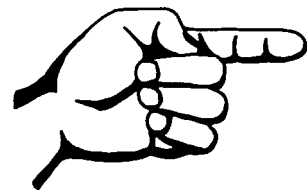

Platform Control Box Wiring Diagram - Diesel Models (from serial number 3242 to 3577)

REV A

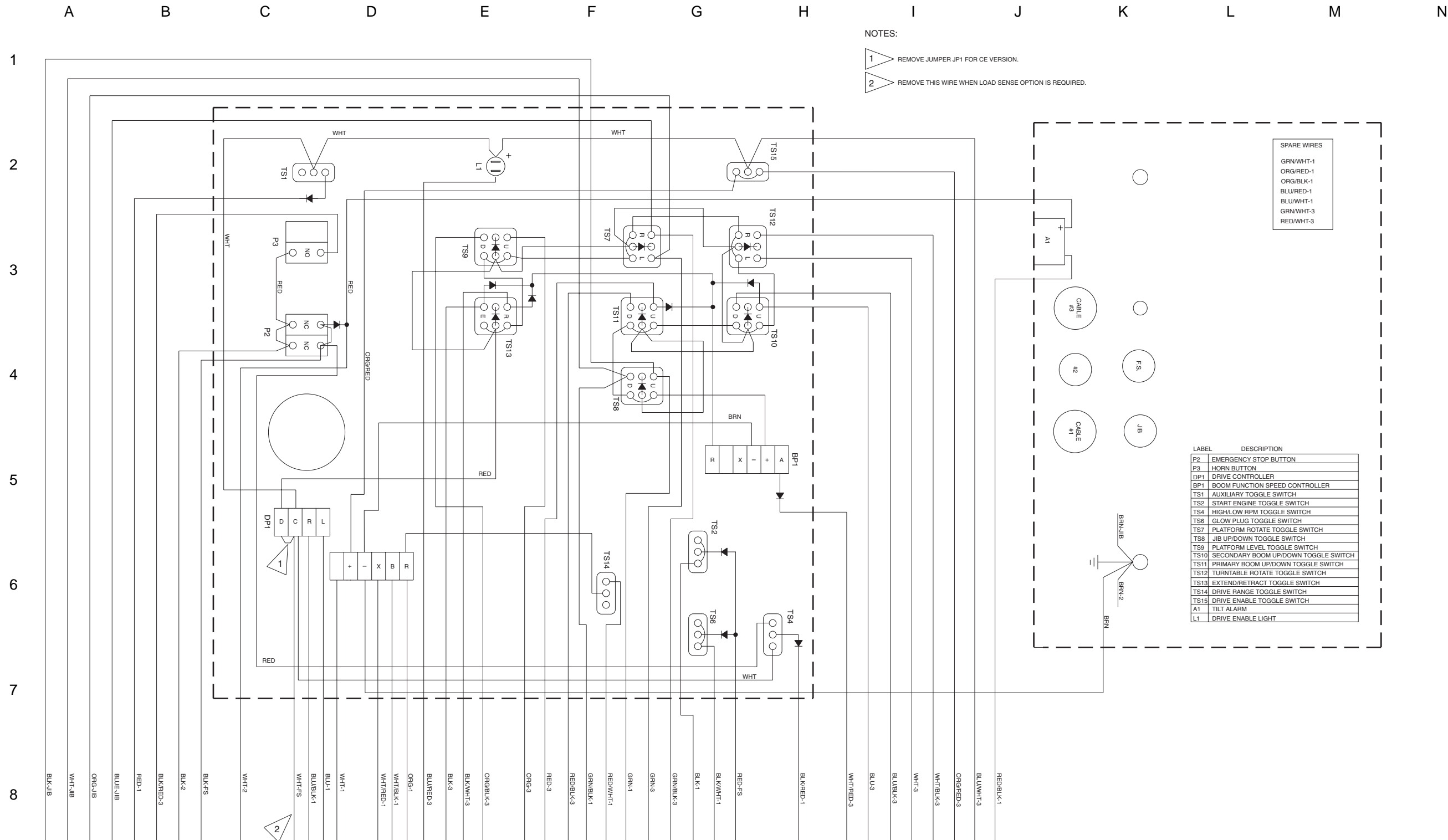

ES34D3N

Platform Control Box Wiring Diagram - Diesel Models (from serial number 3578 to 4799)

REV A

N M L K J I H G F E D C B A

NOTES:

1 REMOVE JUMPER JP1 FOR CE VERSION.

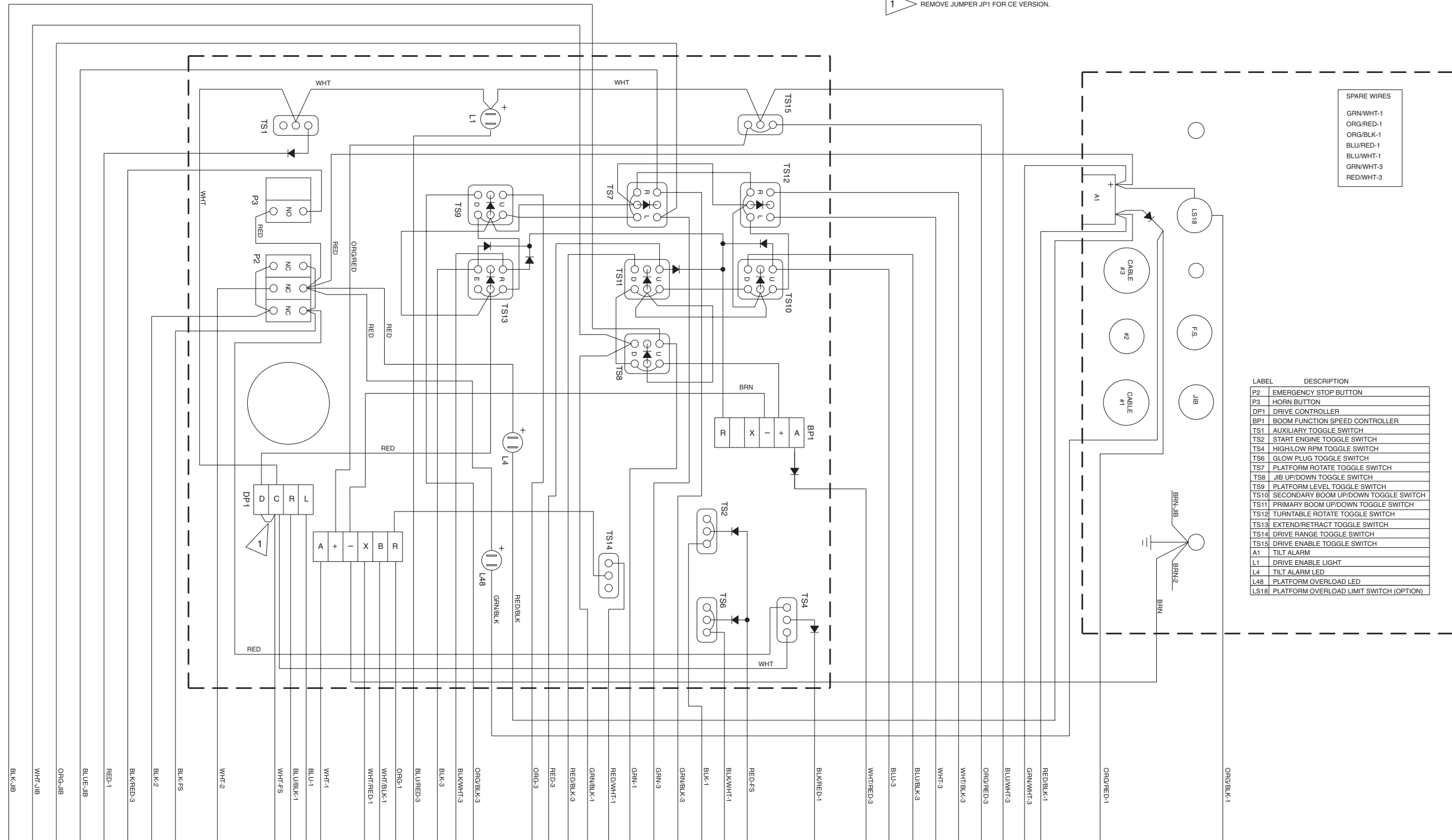

ES34D3T

**Platform Control Box Wiring Diagram - Diesel Models
(from serial number 3578 to 4799)**

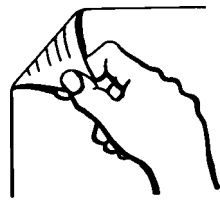

**Platform Control Box Wiring Diagram -
Gasoline/LPG Models
(from serial number 3242 to 3577)**

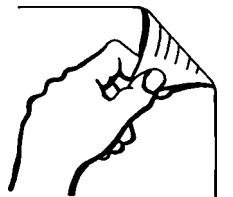
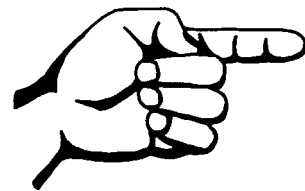

**Platform Control Box Wiring Diagram -
Gasoline/LPG Models
(from serial number 3242 to 3577)**

REV A

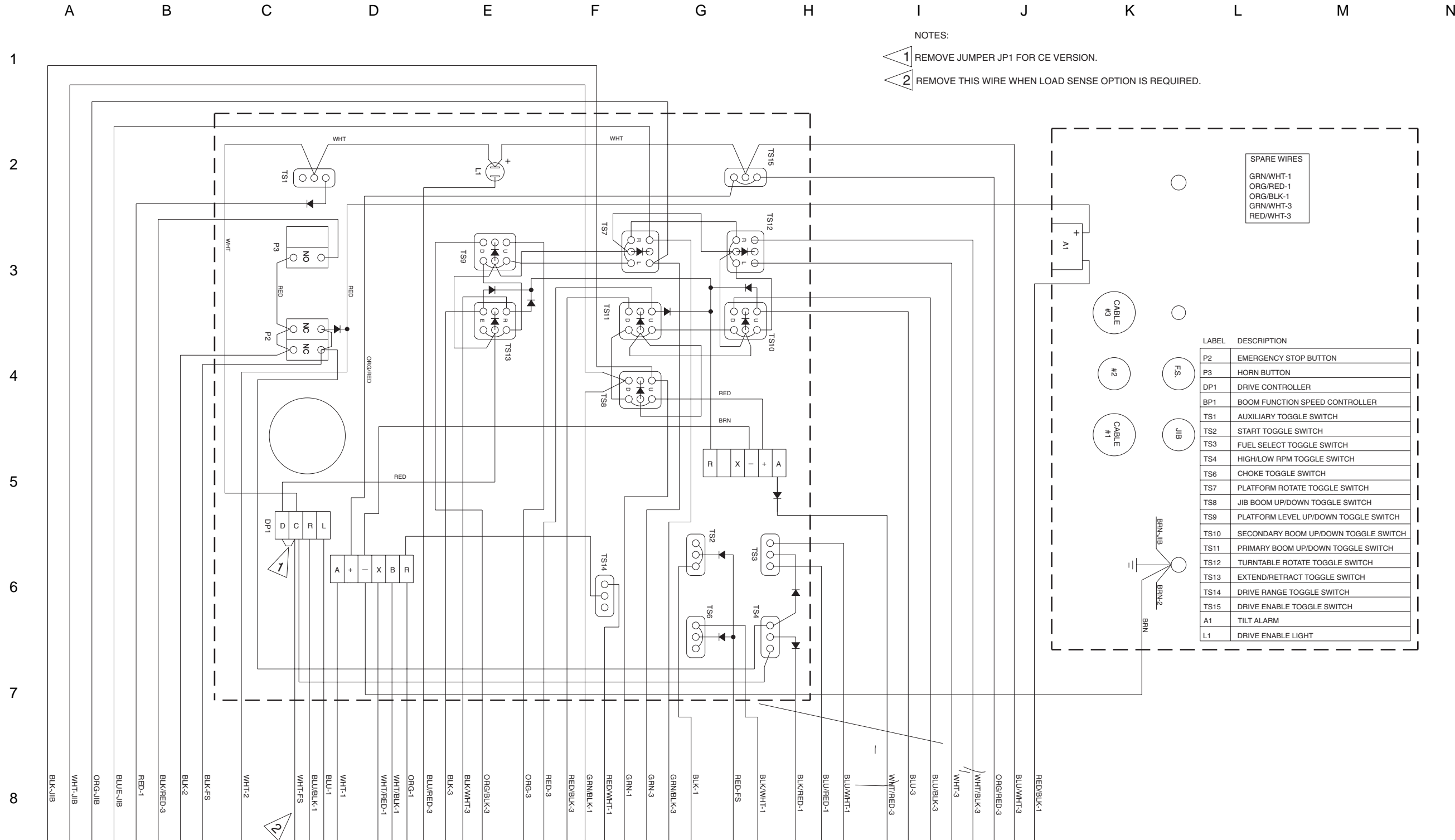

Platform Control Box Wiring Diagram - Gasoline/LPG Models (from serial number 3578 to 4799)

REV A

N M L K J I H G F E D C B A

- NOTES:
- 1 REMOVE JUMPER JP1 FOR CE VERSION.
 - 2 REMOVE THIS WIRE WHEN LOAD SENSE OPTION IS REQUIRED.

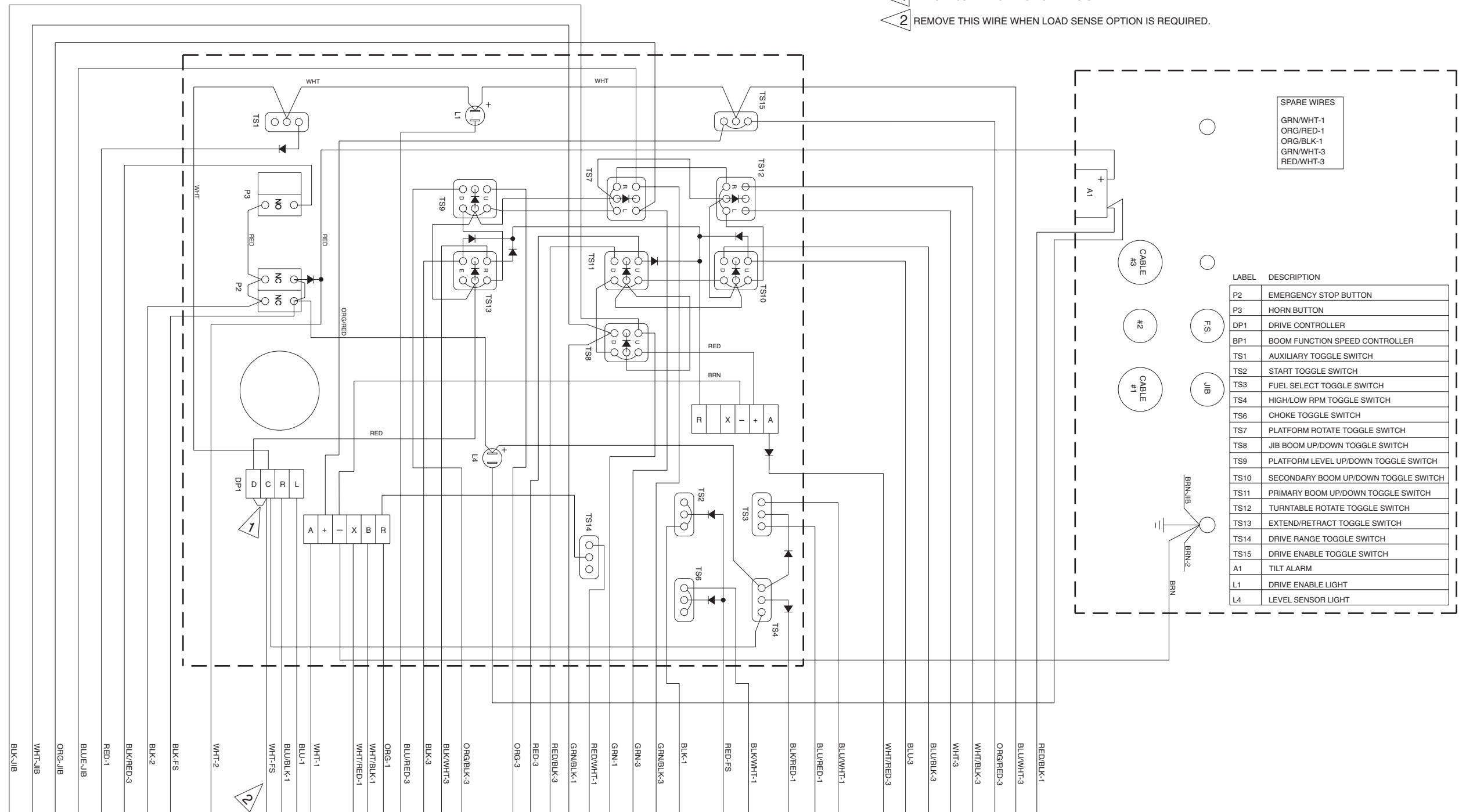

ES34GP3U

**Platform Control Box Wiring Diagram -
Gasoline/LPG Models
(from serial number 3578 to 4799)**

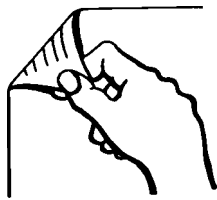

**Generator Option Wiring Diagram
(from serial number 3242 to 4081)**

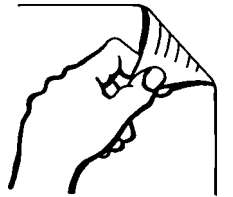
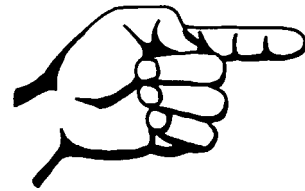

**Generator Option Wiring Diagram
(from serial number 3242 to 4081)**

REV A

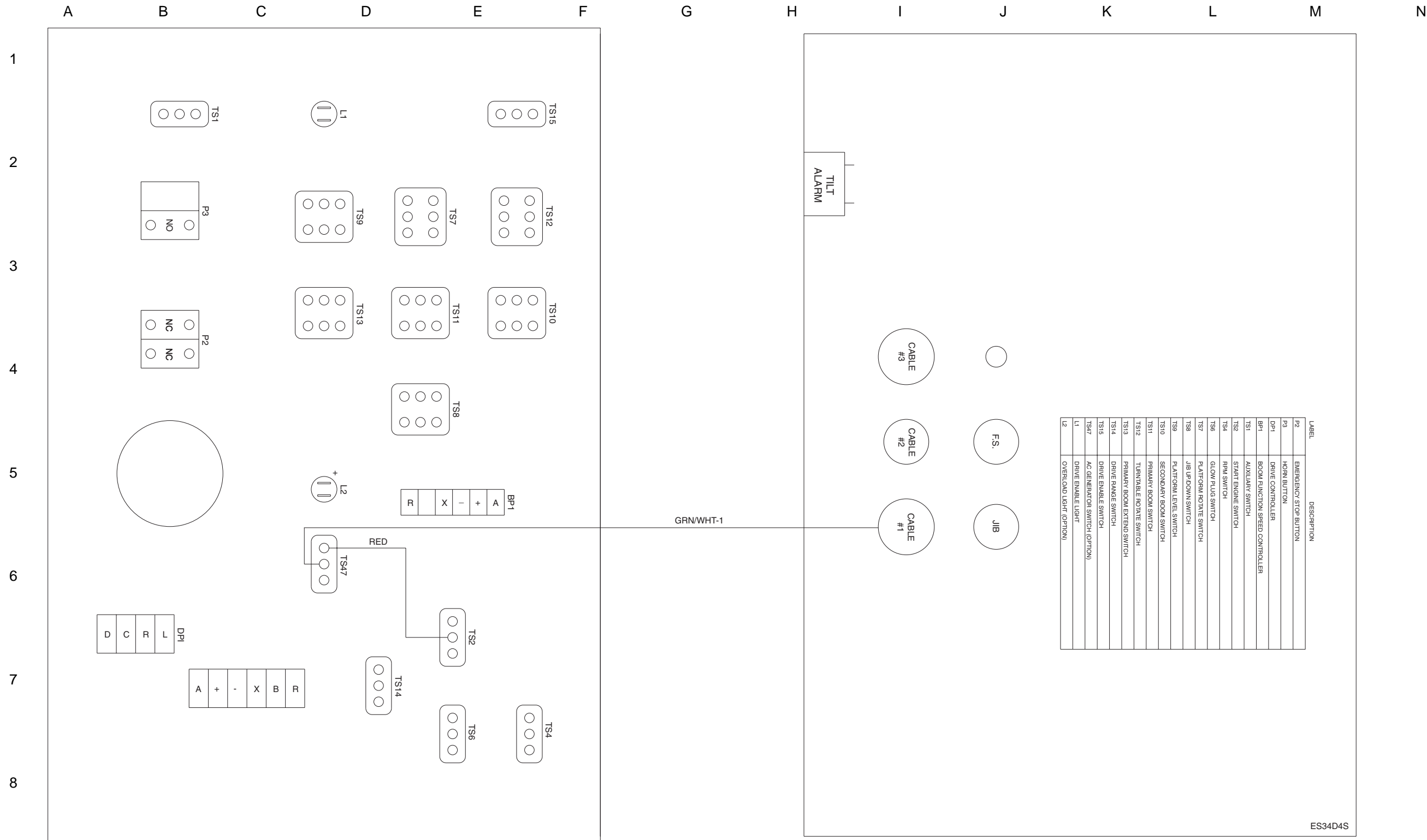

ES34D4S

Generator Option Wiring Diagram (from serial number 4082 to 4799)

REV A

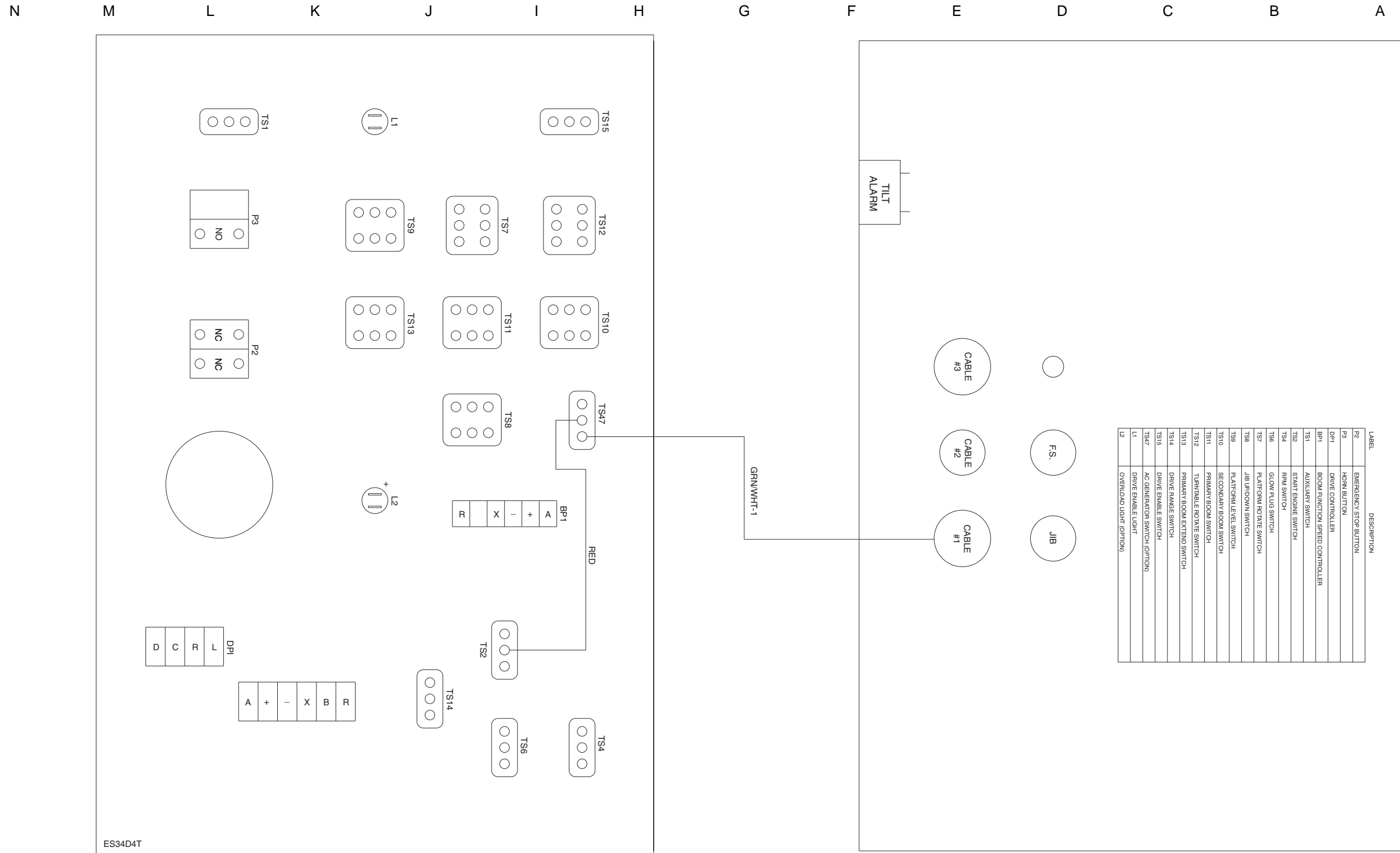

ES34D4T

**Generator Option Wiring Diagram
(from serial number 4082 to 4799)**

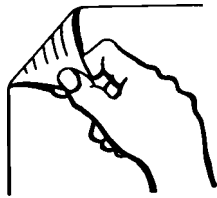

**Load Sense Option Wiring Diagram
(from serial number 3242 to 3577)**

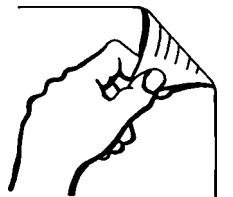
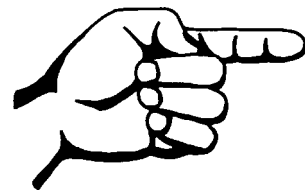

Load Sense Option Wiring Diagram (from serial number 3242 to 3577)

REV A

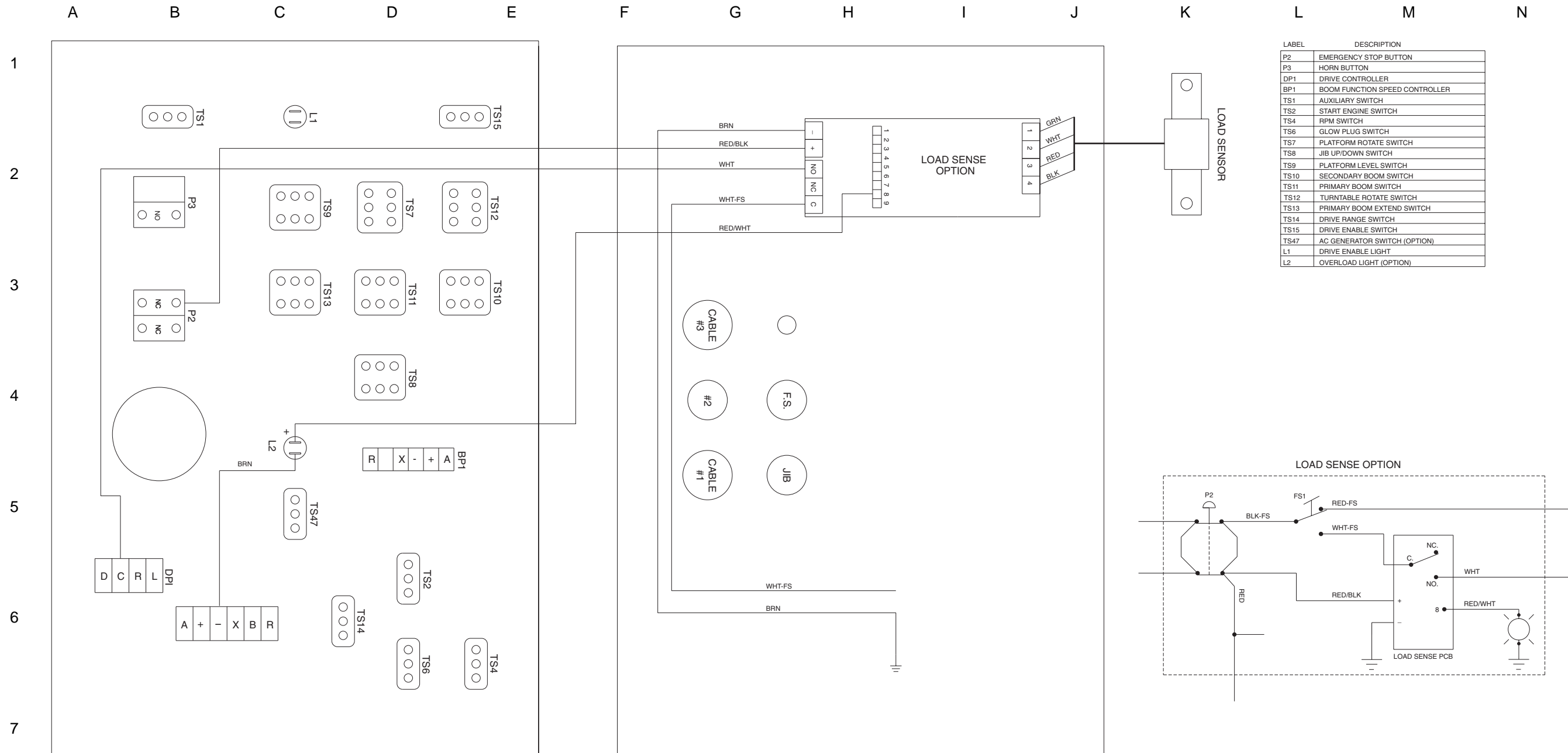

ES34D4N

Manifold and Limit Switch Wiring

REV A

N M L K J I H G F E D C B A

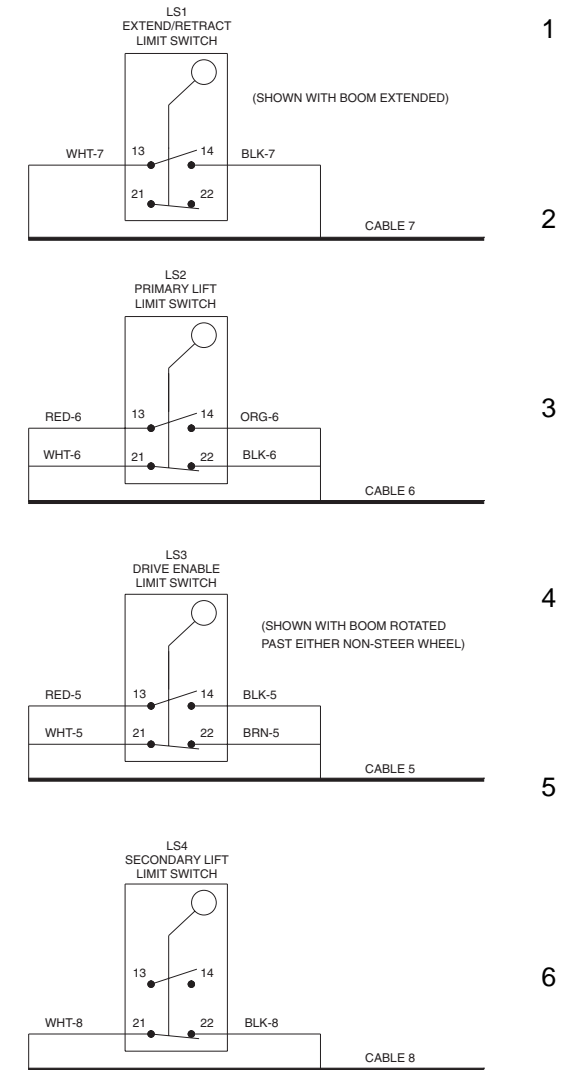
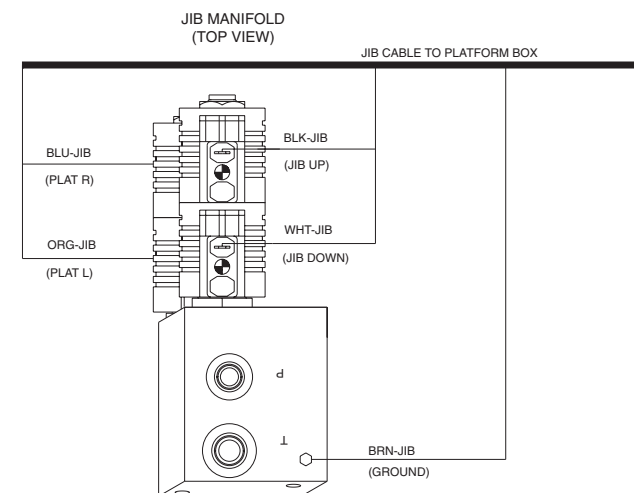
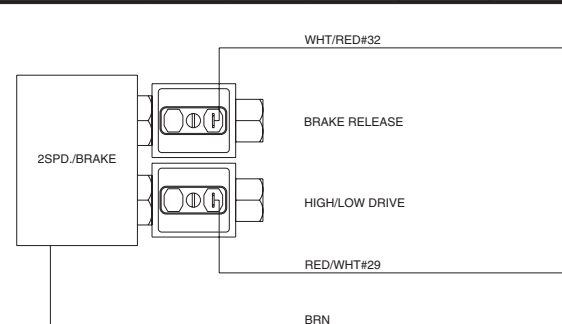
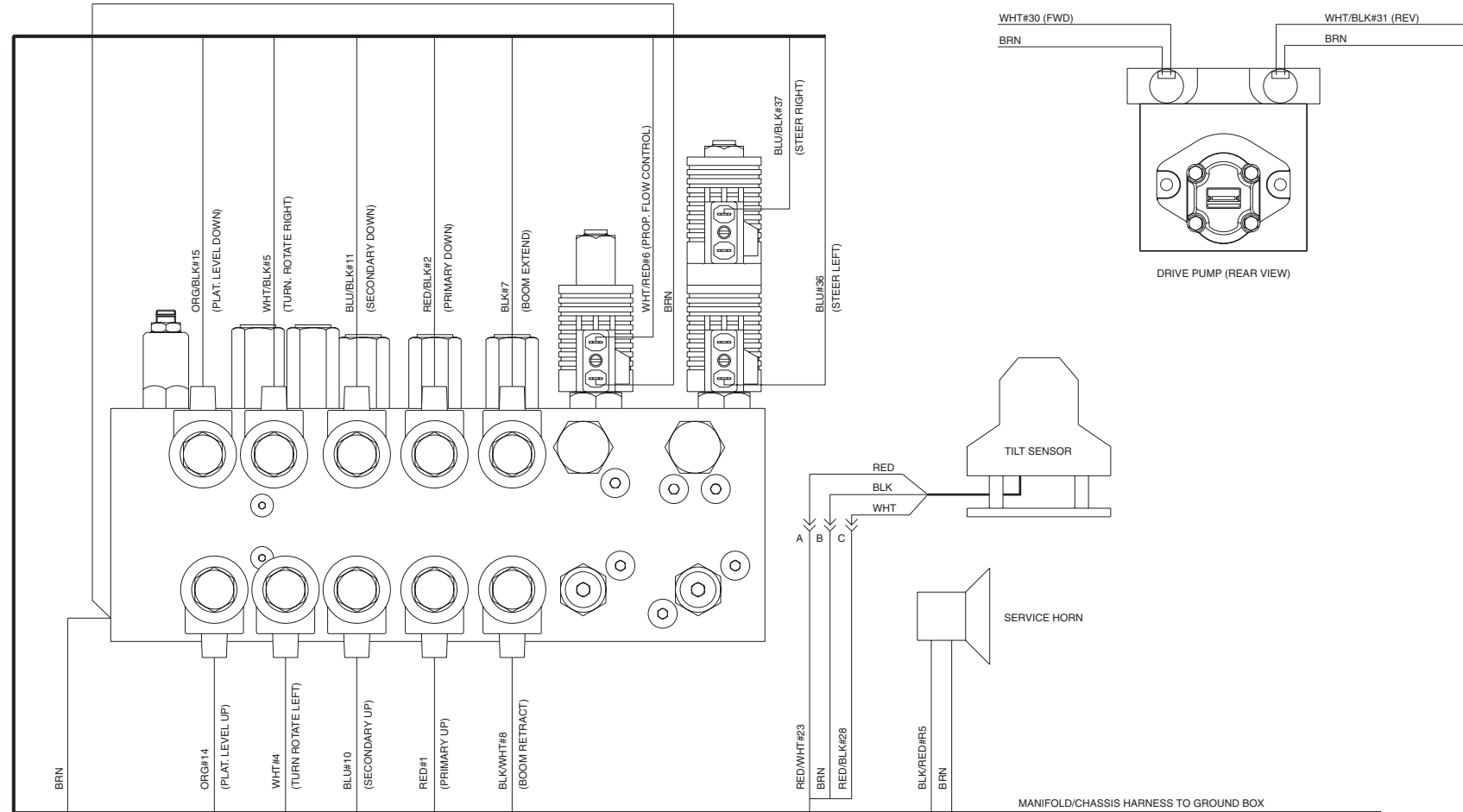

NOTE:
ALL LIMIT SWITCHES SHOWN WITH PLUNGER IN EXTENDED (RELAXED) POSITION. BOOM IS STOWED EXCEPT AS NOTED.

ES34D6T

Manifold and Limit Switch Wiring

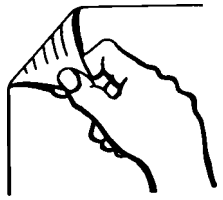

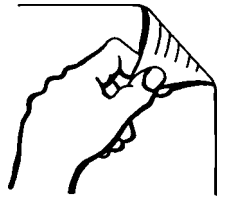
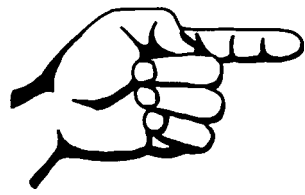

Hydraulic Schematic, 2WD Models

REV A

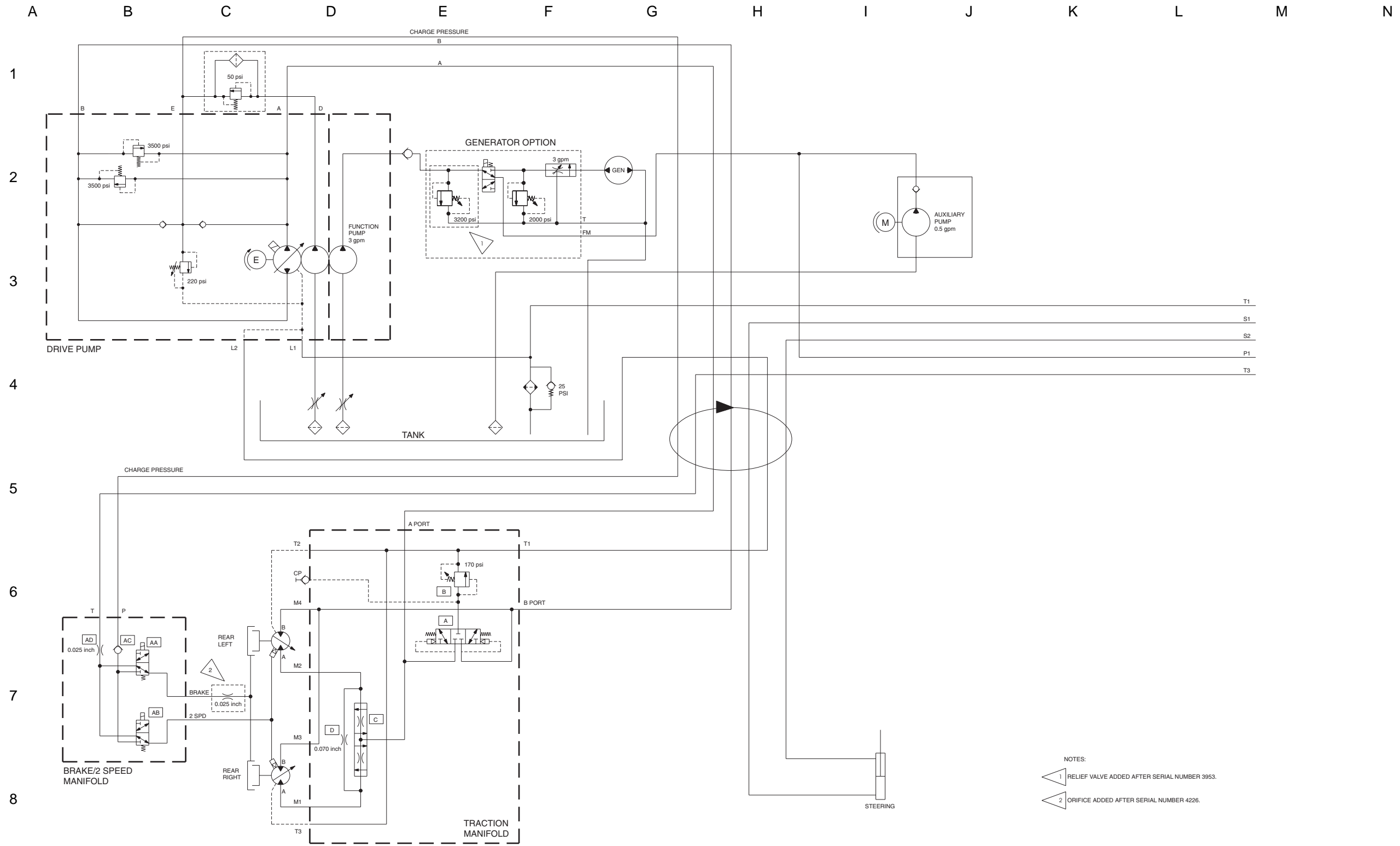

NOTES:

- 1 RELIEF VALVE ADDED AFTER SERIAL NUMBER 3953.
- 2 ORIFICE ADDED AFTER SERIAL NUMBER 4226.

ES342WL

Hydraulic Schematic, 2WD Models

REV A

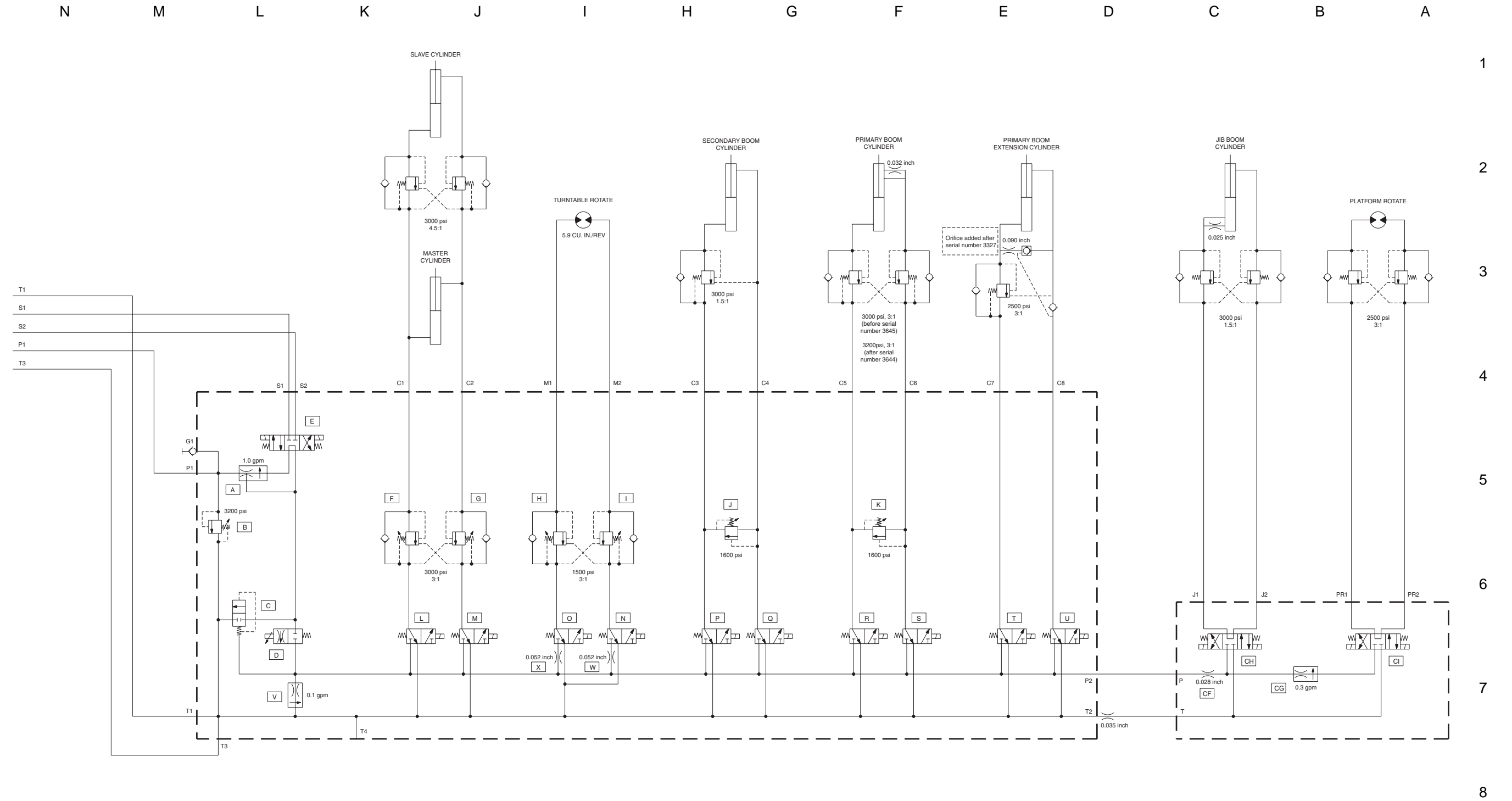

ES342WL

Hydraulic Schematic, 2WD Models

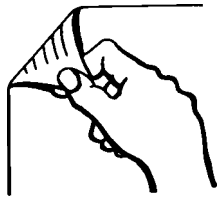

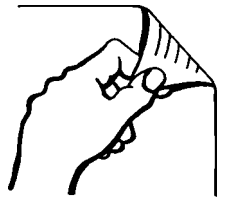
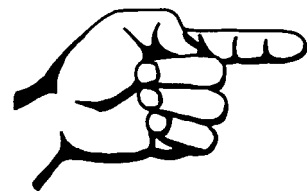

Hydraulic Schematic, 4WD Models

REV A

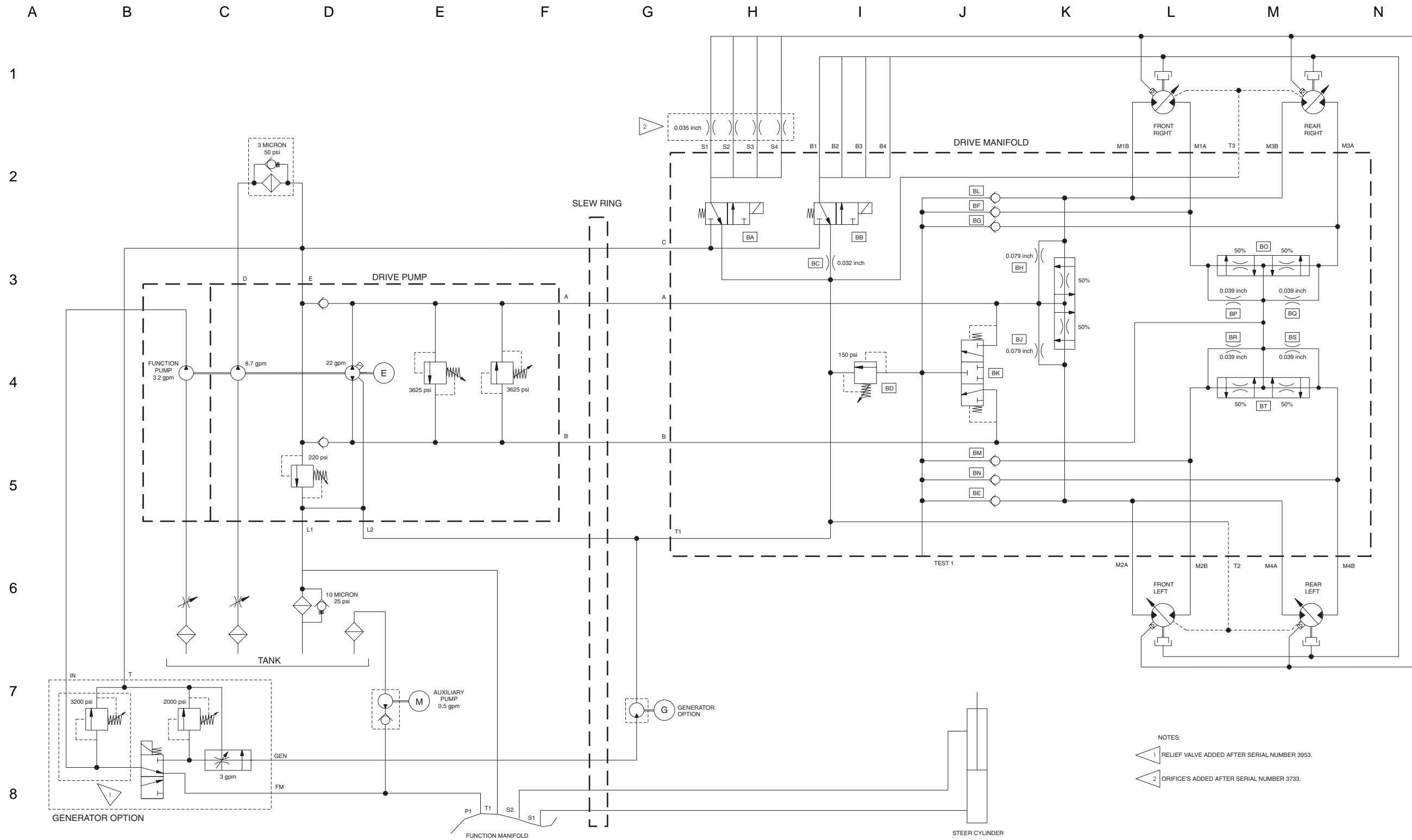

- NOTES:
- 1 RELIEF VALVE ADDED AFTER SERIAL NUMBER 3953.
 - 2 ORIFICE'S ADDED AFTER SERIAL NUMBER 3733.

ES344WM

Hydraulic Schematic, 4WD Models

REV A

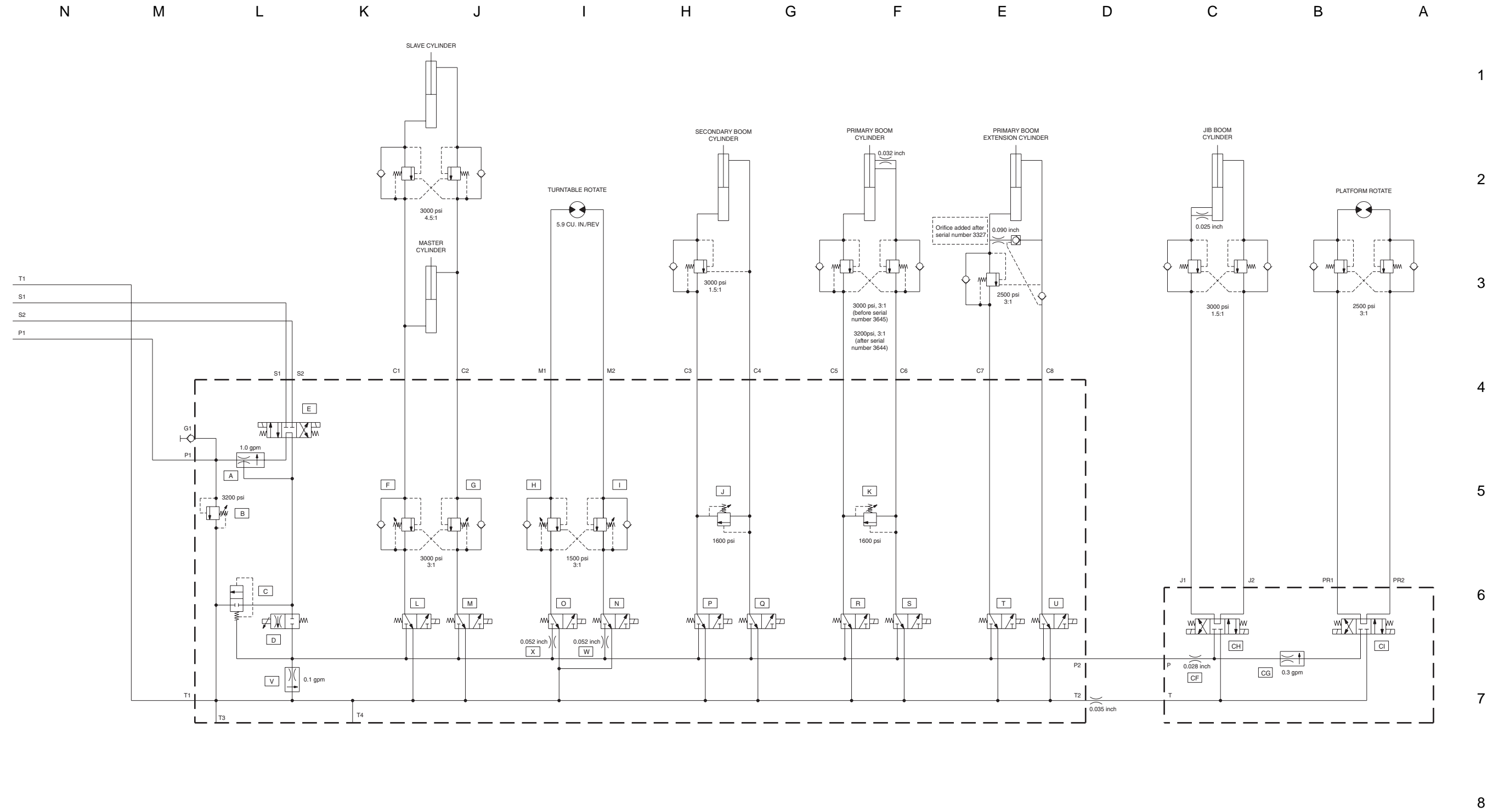

ES344WM

Hydraulic Schematic, 4WD Models

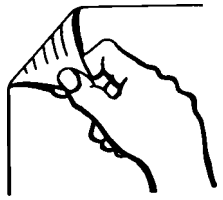

California Proposition 65

WARNING

The exhaust from this product contains chemicals known to the State of California to cause cancer, birth defects or other reproductive harm.

Genie Scandinavia
Phone +46 31 575100
Fax +46 31 579020

Genie France
Phone +33 (0)2 37 26 09 99
Fax +33 (0)2 37 26 09 98

Genie Iberica
Phone +34 93 579 5042
Fax +34 93 579 5059

Genie Germany
Phone 0800 180 9017
Phone +49 422 149 1818
Fax +49 422 149 1820

Genie U.K.
Phone +44 (0)1476 584333
Fax +44 (0)1476 584334

Genie Mexico City
Phone +52 55 5666 5242
Fax +52 55 5666 3241

Genie North America
Phone 425.881.1800
Toll Free USA and Canada
800.536.1800
Fax 425.883.3475

Genie Australia Pty Ltd.
Phone +61 7 3375 1660
Fax +61 7 3375 1002

Genie China
Phone +86 21 53852570
Fax +86 21 53852569

Genie Malaysia
Phone +65 98 480 775
Fax +65 67 533 544

Genie Japan
Phone +81 3 3453 6082
Fax +81 3 3453 6083

Genie Korea
Phone +82 25 587 267
Fax +82 25 583 910

Genie Brasil
Phone +55 11 41 665 755
Fax +55 11 41 665 754

Genie Holland
Phone +31 183 581 102
Fax +31 183 581 566

Distributed By: