



SHOP PRACTICES
& SPARE PARTS 13/14

SHOP PRACTICES & SPARE PARTS 13/14



CERTIFICATION AND INDEMNIFICATION 1

2013/2014 Certification Program	2
Alpine Binding Liability Indemnification	4
Binding Quick Reference Chart	7

BINDING SYSTEMS 9

Preparation	9
Installation	10
Binding-to-Boot Adjustments	15
Model-Specific Instructions	17
Release Value Selection & Adjustment	25
Final Checking & Visual Inspection	27
Mechanical Inspection	28
Retail-Specific Instructions	30
Rental-Specific Instructions	32
Post Accident Record Keeping	37
Binding Maintenance & Repair	38

CERTIFICATION EXAM 40

Technician Certification Exam	40
2013/2014 Atomic/Salomon Adjustment Chart	42
Technician Certification Answer Form	43

ALPINE SKI 44

Technical Features	44
--------------------	----

ALPINE BOOT 45

Standard Boot Norms	45
Technical Features	46
Canting and Lifters	47

SPARE PARTS 48

WARRANTY 64

ATOMIC RACE MODELS 65

The 2013/2014 Shop Practices Manual is published by Amer Sports for Authorized Alpine Binding Dealers. This manual provides current technical information, certification requirements, and indemnification information. Please keep a copy of this Manual on hand as a quick, easy, and reliable reference for servicing Atomic and Salomon alpine bindings. Because the content of the Manual changes every year, you should keep previous editions available as references for servicing older products. The Atomic and Salomon certification websites are your resource for all archive materials.

Together, Atomic and Salomon continue to be the top brands in winter sports worldwide. Our goal is to advance our breakthrough technologies featuring innovation in safety and performance binding systems.

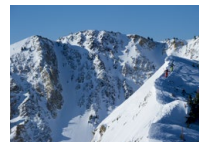

Cover Photo
Photographer: Scott Markewitz.

CERTIFICATION AND INDEMNIFICATION

Photo: Christopher Spstrom



ATOMIC



salomon

2013/2014 Certification Kit

This manual forms part of a kit which is available each year to Authorized Dealers. Enclosed in the kit you will find the necessary materials to certify your shop technicians for mounting and adjusting Atomic and Salomon Bindings for the 2013/2014 season. This packet should have the following items:

- 2013/2014 Shop Practices Manual & Spare Parts
- Skier Classification Chart
- Visual Indicator Adjustment Chart
- Toe Height Adjustment Card

If this packet is missing any of the listed items, or if you wish to order additional quantities of any of the components of the kit, please contact Customer Service at **1 (800) 654-2668** (in the U.S.) **1 (800) 361-3398** (in Canada).

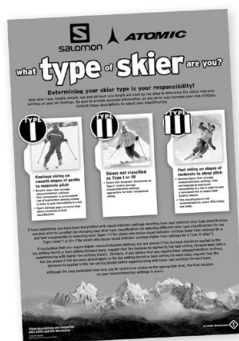

Electronic Documentation

An electronic version of the 2013/2014 Shop Practices Manual is available online at www.atomiccertification.net or www.salomoncertification.com (in the U.S.) or www.atomiccanada.net or www.salomonhookup.ca (in Canada). The online PDF version of the Shop Practices Manual is continuously updated with the most current technical language and thus may have additions not appearing in the print version of the Shop Practices Manual. The printed version of the Shop Practices Manual is still completely valid and all procedures described within follow industry standards.

2013/2014 CERTIFICATION PROGRAM

Authorized Alpine Dealers – Requirements, Fees and Information

Amer Sports provides its Authorized Alpine Binding Dealers with information contained in this Publication:

1. To help assure skiers that Atomic and Salomon alpine bindings are properly selected, mounted, adjusted, and serviced.
2. To serve as a risk management tool for the Authorized Dealer.

Requirements

While it is not necessary for an Authorized Location to have all of its personnel certified, sales people and managers are encouraged to remain aware of Amer Sports' certification and record keeping requirements.

- Authorized Dealers must have at least one Certified Technician working at each Authorized Location selling, servicing or renting Atomic or Salomon alpine bindings.
- The technician who signs the Authorized Location's workshop or rental form for any transaction must be currently certified.
- It is an Authorized Dealer's responsibility to maintain sufficient records to identify its Certified Technicians.

Certification Fees

Authorized Dealers will be invoiced an administrative registration fee for technician certifications.

U.S. Dealers

- For the U.S., a \$12 fee will be invoiced for each Registration and Exam submitted on-line at www.atomiccertification.net or www.salomoncertification.com
- The U.S. fee is \$20 for each Registration/ Exam submitted by mail or fax.
Fax: (801) 334-4502
Technician Certification/Customer Service
Amer Sports Winter & Outdoor Company
2030 Lincoln Ave.
Ogden, UT 84401

Canadian Dealers

- For Canada, a \$30.00 fee will be invoiced for each Certification Kit sent to the dealer. Technicians must Register and take the Exam on-line at www.atomiccanada.net or www.salomonhookup.ca

Finding Currently Certified Technicians For Your Shop

Finding currently certified technicians is a service only available in the U.S.

If you need to know who in your shop is certified, log on and search for certified technicians for your shop. An updated list will appear so you have constant access to the information.

1. Log onto either www.atomiccertification.net or www.salomoncertification.com
2. Simply log onto the site and click on the button "Search for certified technicians".
3. Enter your shop ship-to code or certificate number to search the certification database.
4. You may retrieve printable certificates from the database for any certified tech.

2013/2014 CERTIFICATION PROGRAM **continued**

Technicians – Certification Process, Validity and Exam Instructions

Only a technician sponsored by an Authorized Dealer may be certified. Authorized Dealers can log onto www.atomiccertification.net or www.salomoncertification.com (in the U.S.) to receive a current list of their Certified Technicians.

Certification Process

To complete the technician certification process:

1. Read this manual and become familiar with required shop practices.
2. Be familiar with earlier editions of Shop Practices Manuals and Technical Updates.
3. Be familiar with Atomic and Salomon bindings through hands-on experience.
4. For the U.S., log on to www.atomiccertification.net or www.salomoncertification.com. For Canada, log on to www.atomiccanada.net or www.salomonhookup.ca. Complete the on-line 2013/2014 Certified Technician Registration and Exam and receive confirmation of your certification instantly.
5. For the U.S. only, technicians of Authorized Dealers who complete a Ski Mechanics Workshop binding course will have completed Amer Sports certification requirements.

Technician Certification Validity Period and Transfer

- Technician certification is valid for two years from the exam date (unless Amer Sports provides further notice).
- Technician certification is not valid at a location that is not an Authorized Dealer.
- Technician certification may be transferred from one Authorized Dealer to another by contacting the certification coordinator by mail or telephone (Ogden, UT for U.S. dealers and Markham for Canadian dealers).

Instructions For Taking The On-line Exam

Once you have become familiar with the procedures for mounting, adjusting, and testing Atomic and Salomon bindings, take the exam on-line for instant results and obtain your certificate immediately. (If for some reason you are unable to take the test on line, please contact your sales representative.) Just follow these easy steps:

1. Log onto the certification website

- In the U.S. log onto www.atomiccertification.net or www.salomoncertification.com
- In Canada log onto www.atomiccanada.net or www.salomonhookup.ca

2. Register your information

- Once you have signed in, you will get a prompt asking you to confirm your login-ID. Write this information down in case you need to stop your test in the middle and return later.

3. Take the on-line exam

- Once the test begins, **do not use your web browser to move “back” or “forward”**. Doing this will result in a cancelled session and you will need to start at the beginning.
- A score of 90%, or 23 correct answers, must be obtained to pass.
- In addition, questions 12 to 25 are considered core questions and must be answered correctly.

4. Once you pass the test

In the U.S.:

- Click on the button to create a printable certificate in PDF format. **OR** Write down your certificate number and return later to retrieve your printable certificate.
- An invoice for \$12 will be generated and sent to your shop. If you do not pass, your shop will not be invoiced. Only passing exams will receive certificate numbers and generate an invoice.

In Canada:

- Click on the Download Certificate box to create a printable certificate. (The certificate will be created in PDF format. If you do not have Adobe Reader on your computer, click on the icon and you can download it free from the web.) **OR** click on e-mail Certificate to receive an e-mail version.

ALPINE BINDING LIABILITY INDEMNIFICATION

2013/2014 Schedule of Indemnified Bindings

Amer Sports alpine binding indemnification applies to the 2013/2014 Retail Binding Line, 2013/2014 Rental Binding Line, Non-current Retail Binding Line and Non-current Rental Binding Line models listed below. Indemnification does not apply to older non-indemnified binding models.

Non-Indemnified Bindings

Older models of bindings no longer on the Schedule of Indemnified Bindings may still be serviced, however **Liability Indemnification will not be offered by Amer Sports for these models of bindings.** Dealers wishing to service these models of bindings can reduce their liability risk by requiring an additional waiver and release agreement and attaching it to the Workshop Form. Such waivers should be reviewed by a dealer's own legal counsel to ensure compliance with applicable laws.

Atomic and Salomon bindings are not designed or tested for use with **Monoboards**, therefore bindings mounted on Monoboards will not be indemnified.

Salomon Retail

Z 14 Speed	Z 920 Lab	STH 12 Driver	S 912	S 810	LZ 7	C 509	610
Z 12 Ti	Z 916 Lab	STH 12	S 910 T PS	S 711 PS	L 9 W	C 5 Easytrack	609
Z 12 Speed	Z 914 Lab	S 914 Pilot	S 910 T FIS	S 711 PA	L 9	C 305 MINI	608
Z 12	Z 14	S 914 PE2	26.3/24/20	S 711 CP	L 7 Easytrack	GROM	607
Z 10 Ti W	Z 12 Ti Smartrak	S 914 Lab	S 910 T Axe+	S 710 Ti Pilot	Guardian 16	C 305 MINI	305
Z 10	Control	S 914 FIS Pilot	S 910 T	S 710 Ti CP ²	C509 D+	C 305 GROM	
X 20	Z 11	S 914 FIS	S 910 FIS 24	S 710 Ti	C 610 CP ²	C 305	
X 16	Z 10 Ti Axe +	26.3/20/17	S 910	S 710 SC Pilot	C 610 CP	920 Equipe Race	
X 12	Z 10 Ti	S 914 FIS	S 812 PA	S 710 Pilot	C 610	916 Equipe Comp	
STH ² WTR 16	Z 10 Smartrak	S 914 Axe+	S 811 PS	S 710 PA	C 609 Ti	914 FIS	
STH ² WTR 13	Control	S 914	S 810 Ti SC Pilot	S 710 DP	C 609 D+	914 FIS 20	
STH 12	Z 10 FIS 20	S 912 Ti Pilot	S 810 Ti PS	S 710 CP ²	C 609	710 Smartrak	
STH 10	TZ 5	S 912 Ti PE ²	S 810 Ti Pilot	S 710 CP	C 608 FIS 17	Grip	
L 7	T 5	S 912 Ti	S 810 Ti Axe+	S 710	C 608 CP ²	610 CP	
L 10	STH 16	S 912 PS	S 810 Ti	S 608 CP	C 608 CP	609 D+	
Guardian WTR 16	STH 14 Driver	S 912 FIS Pilot	S 810 PS	S 305 GROM	C 608	914	
Guardian WTR 13	STH 14	S 912 FIS 24	S 810 Pilot	LZ 9	C 607	711	
C 5	STH 12 Oversized	S 912 FIS	S 810 CP	LZ 8	C 509 Dr+	710	

Salomon Rental

Z 12 SC	Z 12 Ti SC	S 912 Ti SC Pilot	Q 500 SR	LZ 7 SR	C 608 SC	609 SR	Snowrip ST 410
Z 10 SC	Z 12 Smartrak	S 912 Ti SC	Q 500 SC Drive	L 9 W SC	C 607 SR	609 SC	Quadrax 6 SC
L 10 SC	Z 10 Ti SC	S 810 Ti SC	Plus	L 7 SC	C 607 SC	608 SC	Quadrax 5 SR
L 10 SR	Z 10 Smartrak	S 700 SR	Q 500 SC	L 10 SC	C 509 SR	607 SR	Quadrax 3 SR
L 10 Easytrak	TZ 5 SR	S 700 SC Drive	Q 400 SR	Cosmic S 712 SC	C 509 SC	305 SR	Quadrax 3 SC
L 9 W Easytrak	TZ 5 SC Junior	Plus	Q 300 SR	Cosmic S 710 SR	C 5 SR	305 SC	Q 700 SC
L 7 SR	Track	S 700 SC	Q 300 SC	Cosmic S 710 SC	C 305 SR		Q 7 SR
L 7 Easytrak	TZ 5 SC	S 305 SC	Q 3 SR	Cosmic S 710	C 305 Grom SR		Q 7 SC
C 5 Easytrak	T 5 SR	S 305 Grom SC	Q 3 SC	C 609 SC	711 SC		Q 5 SR
	T 5 SC	S 300 SC	LZ 8 SC	C 608 SR	710 SC		

Tecno Pro Retail and Rental

TX 110	TL 100	TL 75	TL 100 SC	TL 90 W	TL 75 SC	TC 45 SR
TL 100 CP	TL 90	TC 45	TL 100 ET	TL 90 CP W	TL 75 ET	TC 45 ET

Scott Retail and Rental

S 14	S 10 SC	Guardian BC 16
S 12 Ti SC	S 10	Guardian BC 13

How to read the list

Current Line ##### Final season

ALPINE BINDING LIABILITY INDEMNIFICATION **continued**

Authorized Dealers

Amer Sports offers liability indemnification to Authorized Dealers. Amer Sports will, to the extent, and within the limits that insurance coverage is available, defend and indemnify an Authorized Alpine Binding Dealer against liabilities from claims presented by any customer of the Authorized Dealer arising solely from the use of Atomic or Salomon alpine bindings, provided:

- A. The dealer purchased the alpine bindings from Amer Sports or one of its OEM partners.
- B. The dealer has received written notice of a claim involving alpine bindings.
- C. The claim alleges use of the alpine bindings resulted in injury.
- D. All recommendations, procedures and policies in effect at the time of the incident were followed, including, but not limited to, those contained in the Shop Practices Manual, Technical Updates (if applicable), Purchaser Policies and General Terms & Conditions.
- E. The Certified Technician is of legal age, defined as the "legal age to work," according to the laws of each state or province.
- F. The dealer uses workshop and/or rental forms the same as, or equivalent to, Atomic/Salomon forms with currently approved Liability Release Language.
- G. The dealer maintains proper and complete records for all bindings mounted and/or adjusted for a period of five years or the statute of limitations of the state or province, whichever is longer.
- H. The dealer provides written documentation of the technician's employment or sponsorship, and training (e.g., method of training, proof of certification, etc.).
- I. A copy of the properly completed workshop form or rental form, including a signed release, is submitted.
- J. A properly completed Post Accident Ski Equipment Inspection Report, the same as or equivalent to the exemplary form displayed in this manual, is submitted.
- K. Any other helpful information such as a Ski Patrol Incident Report Form is submitted.
- L. The dealer provides Amer Sports with prompt notice of the claim.
- M. The dealer cooperates fully in the investigation, litigation and/or settlement of the claim.

Amer Sports may terminate indemnification, with respect to alpine bindings, upon providing written notice to the dealer.

Legal Claims

In the event an equipment user or anyone acting upon the equipment user's behalf contacts the Authorized Dealer regarding a potential claim:

- 1. Use your best efforts to determine the exact nature and details of the claim.
- 2. Avoid expressing opinions concerning the claim. You may, to the extent that you have complied with all recommended procedures, indicate to the claimant or the claimant's representative that recommended procedures for service and adjustment of the equipment were followed.
- 3. Notify your insurance company. Amer Sports indemnification is not a substitute for liability insurance.
- 4. Gather all information and documents listed in the Liability Indemnification section for that specific product and send the documents with a brief description of the incident to:

U.S.A.

Alpine Legal Claims Department
Amer Sports Winter & Outdoor Company
2030 Lincoln Ave.
Ogden, UT 84401

Canada

Legal Claims Department
Amer Sports Canada, Inc.
85 Davy Rd, PO Box 909
Belleville Ontario K8N 5B6

BINDING QUICK REFERENCE CHART

Model	Part Number	Brakes	Recommended Jig Part #	Jig Selection SW Width (mm)	Visual Indicator Range	Height (mm)	Skier (kg)	Skier (lb)	Adjustment Range (mm)	Fits Boot Sole Length (mm)	Adjustment Range (US Size)	Weight 1/2 pair (g)	(H) Micro (A) Automatic Wing Adj. (H) Wing Height adjustment (V) Vertical Progressive Pivot	AFD Part Reference #	(A) Adult (J) Junior Boot Norms Screw / Drill Bit Length (mm)	Ski Binding Interface
-------	-------------	--------	------------------------	-----------------------------	------------------------	-------------	------------	------------	-----------------------	----------------------------	----------------------------	---------------------	---	----------------------	---	-----------------------

ATOMIC RETAIL

RACE / SPEED																
X 20 EGA Black Yellow	AD5001582	X70	AZD000084		12-20	16.2			100	260-370	13	1760	A	AZD000124	A	
X 19 VAR Black Yellow	AD5001584	X70	AZD000084		11-19	16.2			100	260-370	13	1607	A	AZD000124	A	
X 16 VAR Black Yellow	AD5001586	X70	AZD000084		9-16	17.5	>95	>209	100	249-364	13	1480	A	AZD000114	A	
X 12 Black Yellow	AD5001590	X70	AZD000084		4-12	17.5	42-120	92-264	100	249-364	13	1480	A	AZD000114	A	9.5
BACK-COUNTRY																
N Tracker 16 L Blk Orange	AD5001408	C100 C115 C130	L3267050001	56-143	7-16	26	>60	>130	55	305-360	7	1480	A H	L1202730001	A	9.5
N Tracker 16 S Blk Orange	AD5001410	C100 C115 C130	L3267050001	56-143	7-16	26	>60	>130	55	260-320	7	1480	A H	L1202730001	A	9.5
N Tracker 13 L Black White	AD5001404	C100 C115	L3267050001	56-143	5-13	26	50-125	110-275	55	305-360	7	1460	A	L1202730001	A	
N Tracker 13 S Black White	AD5001406	C100 C115	L3267050001	56-143	5-13	26	50-125	110-275	55	260-320	7	1445	A	L1202730001	A	
STH ²																
N STH ² WTR 16 Black Orange	AD5001310	C90 C115 C130	L3298160001	56-143	7-16	18.3	>60	>130	28		3.5	1220	M H	L1202730001	A	
N STH ² WTR 13 Black Silver	AD5001312	C90 C100 C115	L3298160001	56-143	4-13	18.3	50-125	110-275	28		3.5	1145	M H	L1202730001	A	
PERFORMANCE																
N FFG 12 Black	AD5001306	B90 B100 B115	L0011570001	80-123*	4-12	16.5	42-120	94-264	28		3.5	1050	A V	L7883010001	A	9.5
N FFG 12 White	AD5001304	B90 B100 B115	L0011570001	80-123*	4-12	16.5	42-120	94-264	28		3.5	1050	A V	L7883010001	A	9.5
SPORT																
N FFG 10 White Black	AD5001314	B90 B100	L0011570001	80-123*	3-10	16.5	30-107	66-235	28		3.5	970	A V	L7883010001	A	9.5
JUNIOR																
N FFG 7 White	AD5001316	B80 B90	L0011570001	80-123	2-7.5	16.5	22-85	55-187	28		3.5	861	A	L1005670001	A&J	8.0
EVOX 045 bla whi	AD5000254	J75	AZD000064	56-99	0.5-4.5	14	10-45 max	22-100	44		6	561	A	L1005670001	A&J	8.0

ATOMIC SYSTEM

ADULT																
X 12 TL OME Black Yellow	AD5001592	X75	AZD000086		4-12	23	42-120	92-264	105	260-365	13	1430	A	AZD000094	A	9.5
J XTO 12 Race Black Yellow	AD5001048	B75			4-12	31.5	42-120	92-264	120				A	L7883010001	A	
J XTL 10 Race Black Yellow	AD5001570	B75			3-10	31.5	30-107	66-235	120				A	L7883010001	A	
K XTO 14 YI Blk	AD5001566	B80 B90			6-14	31.5	42-120	92-264	120	257-380	15	1310	A	L7882950001	A	
K XTO 12 Black Yellow	AD5001568	B80 B90			4-12	31.5	42-120	92-264	120	257-380	15	1310	A	L7882950001	A	
KR XTO 10 Black Red	AD5001594	B80			3-10	31.5	30-107	66-235	120	257-380	15	1305	A	L7882950001	A	
K XTO 10 AF White Purple	AD5001364	B90			3-10	31.5	30-107	66-235	120	257-380	15	1100	A	L7882950001	A	
E XTE 10 Lady White Lime	AD5001362	B80			3-10	30	30-107	66-235	107	229-336	13	930	A	L1005670001	A	
E XTE 10 Lady White Black	AD5001352	B80			3-10	30	30-107	66-235	107	229-336	13	930	A	L1005670001	A	
JUNIOR																
J XTL 7 Black Yellow	AD5001572	B75			2-7.5	16.5	22-85	55-187	28				A	L1005670001	A&J	
E Ezytrak 7 Black White	AD5001266	B75			2-7.5	30	22-85max	55-187	107		13	950	A	L1005670001	A&J	
E XTE 7 White Turquoise	AD5001258	B75			2-7.5	30	22-85max	55-187	107		13	950	A	L1005670001	A&J	
E XTE 7 Red White	AD5001252	B75			2-7.5	30	22-85max	55-187	107		13	950	A	L1005670001	A&J	
E Ezytrak 5 Black White	AD5001264	J75			0.5-4.5	28	10-45max	22-100	107	197-304	13	610	A	L1005670001	A&J	
E XTE 045 White Turquoise	AD5001260	J75			0.5-4.5	28	10-45max	22-100	107	197-304	13	610	A	L1005670001	A&J	

ATOMIC RENTAL

ADULT																
NR FFG 12++ White Black	AD5001166	B90 B100 B115	AZD000076	80-123*	4-12	31.5	42-120	92-264	122	260-384	15	1386	A V	L7883010001	A	9.5 Synchron-Center
NR XTE 10 ++ Black White	AD5001158	B80	AZD000076	80-123*	3-10	31.5	30-107	66-235	122	260-384	15	1100		L1005670001		
JUNIOR																
NR XTE 7++ Black White	AD5001160	B80	AZD000076	80-123*	2-7.5	30	22-85	55-187	104		13	1145	A	L1005670001	A&J	8.0 Easytrak

BINDING SYSTEMS

Proper procedures for a Certified Technician to follow while mounting and adjusting Atomic and Salomon bindings.

The seven important steps to installing and adjusting are:

- | | | |
|-------------------------------|---|---|
| 1) Preparation | 4) Release Value Selection and Adjustment | 6) Mechanical Inspection |
| 2) Installation | 5) Final Check and System Inspection | 7) Skier Instruction, Warning, and Record Keeping |
| 3) Binding-to-Boot Adjustment | | |

MODEL-SPECIFIC PAGES	
Page #	Binding Concept
17	Salomon Z-Speed
18	X-12 and X-16
19	Atomic Neox
20	Back-Country with WTR
22	STH ² with WTR
23	Smatrak
24	Easytrak

PREPARATION

Start out prepared with an efficient working area. Your bench should be the right height, with proper lighting, and with the necessary tools at hand. Familiarize yourself with all procedures before you start: being prepared is the best way to avoid errors and costly mistakes. It is important that all components match those listed on the workshop form. Refer to your workshop form and make sure the bindings are appropriate for the skier. If the bindings have been used, make sure they are in good condition and no parts are missing, broken, or showing signs of wear. Check the skis' serial number to ensure you are mounting a matched pair.

Boot-to-Binding Compatibility

Before drilling the ski, be sure the boot you are using is compatible with the binding. Only boots that conform with applicable standards may be used with Atomic and Salomon bindings. (See **Standard Boot Sole Dimensions on page 45** for reference). If a boot sole is warped, worn or improperly canted, such that there is more than a 1 mm difference in sole flatness measured across its width, the boot is incompatible.

Other Compatibility Problems You May Encounter

- Cut-outs in the boot sole that prevent the brake from engaging properly.
- Excessive ramping or wear of the boot sole at the point where it contacts the binding. Any wear that

inhibits binding function is excessive.

- Tread, grid pattern or insignia present in the AFD area of the boot sole. This area must be flat over its entire surface.
- Non-compatible boot sole composition. Low-grade thermoplastic (T.P.) boots may not be used with Atomic and Salomon bindings. If you are uncertain as to the quality of the boot sole material, perform the **Clean vs. Lubricated Test as described on page 29**.

Only adult norm boots may be used with adult bindings. Under no circumstances should a junior norm boot ever be used with an adult binding. The following bindings can be used with both junior and adult norm boot soles: Salomon L7, Salomon C5, Atomic FFG 7, Atomic EVOX 045, earlier model indemnified equivalents, and their various retail and rental counter parts.

The added width of an adult norm boot sole somewhat limits the shock absorption capability of these models and they should not be used with a boot sole longer than 304 mm. As a result, it is recommended that an aggressive junior skier with an adult

norm boot sole use a model designed exclusively for adult norm boots.

An Atomic/Salomon toe or heel may not be mounted with another manufacturer's toe or heel. Indemnification and warranty are automatically voided for such mixed systems.

Junior Boot To Binding Compatibility Chart

Atomic Junior Boots Models	Salomon Junior Boot Models												
<table border="1"> <thead> <tr> <th>With Adult Norm Boot Soles</th> </tr> </thead> <tbody> <tr><td>Redster WC 90 & 70</td></tr> <tr><td>Redster Pro 80</td></tr> <tr><td>Waymaker Jr 70</td></tr> <tr><td>Waymaker Jr 4 & Girl</td></tr> <tr><td>Waymaker Jr 3 & Girl (22-23.5)</td></tr> </tbody> </table>	With Adult Norm Boot Soles	Redster WC 90 & 70	Redster Pro 80	Waymaker Jr 70	Waymaker Jr 4 & Girl	Waymaker Jr 3 & Girl (22-23.5)	<table border="1"> <thead> <tr> <th>With Adult Norm Boot Soles</th> </tr> </thead> <tbody> <tr><td>X Max LC</td></tr> <tr><td>Quest Access 70 T</td></tr> <tr><td>X3 60 T (22-26.5)</td></tr> <tr><td>Team (22-26.5)</td></tr> <tr><td>T3</td></tr> </tbody> </table>	With Adult Norm Boot Soles	X Max LC	Quest Access 70 T	X3 60 T (22-26.5)	Team (22-26.5)	T3
With Adult Norm Boot Soles													
Redster WC 90 & 70													
Redster Pro 80													
Waymaker Jr 70													
Waymaker Jr 4 & Girl													
Waymaker Jr 3 & Girl (22-23.5)													
With Adult Norm Boot Soles													
X Max LC													
Quest Access 70 T													
X3 60 T (22-26.5)													
Team (22-26.5)													
T3													
<table border="1"> <thead> <tr> <th>With Junior* Norm Boot Soles</th> </tr> </thead> <tbody> <tr><td>Waymaker Jr 3 & Girl (21)</td></tr> <tr><td>Waymaker Jr 2 & Girl</td></tr> <tr><td>AJ 1</td></tr> </tbody> </table>	With Junior* Norm Boot Soles	Waymaker Jr 3 & Girl (21)	Waymaker Jr 2 & Girl	AJ 1	<table border="1"> <thead> <tr> <th>With Junior* Norm Boot Soles</th> </tr> </thead> <tbody> <tr><td>X3 60 T (18-21)</td></tr> <tr><td>Team (18-21)</td></tr> <tr><td>T2</td></tr> <tr><td>T1</td></tr> </tbody> </table>	With Junior* Norm Boot Soles	X3 60 T (18-21)	Team (18-21)	T2	T1			
With Junior* Norm Boot Soles													
Waymaker Jr 3 & Girl (21)													
Waymaker Jr 2 & Girl													
AJ 1													
With Junior* Norm Boot Soles													
X3 60 T (18-21)													
Team (18-21)													
T2													
T1													

*Boots with Junior Norm Boot Soles should only be used with Junior Norm Bindings.

REFERENCE	
Page #	Section Name
29	Clean vs. Lubricated Test
45	Standard Boot Sole Dimensions

INSTALLATION

Atomic and Salomon bindings can be installed the following ways: by drilling holes into the surface of the ski, by securing bindings to a pre-mounted interface, or by a combination of these two techniques.

Jig Selection & Use

A jig ensures that all holes for binding mounting are drilled in the correct location. The bushings guide the drill bit so that it remains perpendicular to the ski. Preparing a jig for use involves four general steps: **Jig Selection, Jig Adjustment, Jig Positioning** and **Drill Hole Pattern Selection**.

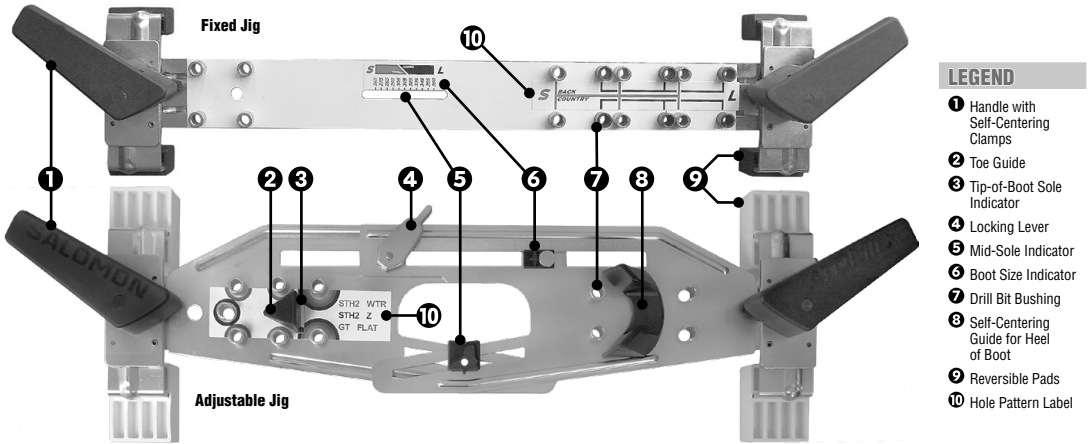

Jig Selection

Select the proper jig for the binding model to be mounted by referencing the following **Jig Reference Guide**.

Jig Reference Guide					
Jig Name	Reference Number**	Application	Fits Ski Widths	Jig Adjustment	Hole Patterns
RETAIL JIGS					
STH[®]	L32981600	Atomic & Salomon STH [®]	56-143 mm	With Boot	STH [®] WTR / STH Z / GT Flat
Backcountry	L32670500	Atomic Tracker, Salomon Guardian	56-143 mm	(Fixed)	S / L
Wide Adult Retail	L00115700	Atomic and Salomon (STH and FFG Team, Z, L, FFG and EVOX)	80-123 mm	With Boot	Driver (4 Hole Toe) / Quadrax (3 Hole Toe)
Adult Retail	AZD000066* L00115600	Atomic and Salomon (STH and FFG Team, Z, L, FFG and EVOX)	56-99 mm	With Boot	Driver (4 Hole Toe) / Quadrax (3 Hole Toe)
Junior Retail	AZD000064 L78406100	Atomic EVOX 045 and Salomon Jr C5	56-99 mm	With Boot	(Single)
Smartrak	AZD000074*	Atomic and Salomon Smartrak Plate	70-116 mm	(Fixed)	Smartrak Interface Plate
Z Speed	L11139300	Salomon Z Speed	70-116 mm	(Fixed)	(Single)
X Bindings	AZD000084	Atomic and Salomon X-Race Bindings		(Fixed)	S / M based on table on page 18
Neox	AZD000086	Atomic Neox Bindings		(Fixed)	< 340 mm / > 340 mm Boot Sole Lengths
RENTAL JIGS					
Wide Rental Jig	AZD000076 L00104000	Adult and Junior Rental Atomic +/++ and Salomon Synchro C and Synchro R	80-123 mm	Model Group	(Multiple)
Rental Jig	AZD000068 L00100300	Adult and Junior Rental Atomic +/++ and Salomon Synchro C and Synchro R	56-99 mm	Model Group	(Multiple)
Easytrak	L30863000	Atomic and Salomon Easytrak Plate	70-116 mm	(Fixed)	Easytrak S / M / L Interface Plate

*Final year jig code ##### is offered.

**When two reference numbers are present, both refer to the same jig. Part Numbers begin with a prefix indicating the brand ("A" for Atomic and "L" for Salomon)

INSTALLATION (continued)

Jig Adjustment

Fixed Jigs (as identified in the Notes column of the **Jig Reference Guide** on page 10) have static hole positions that require no length adjustment (proceed to **Jig Positioning** below). Adjustable Jigs must first be set to a specific length to ensure a correct distance between the toe and heel holes. Adjustable Retail Jigs use the boot to establish the distance, while Adjustable Rental Jigs use labelled Adjustment Settings based on the category of binding being installed.

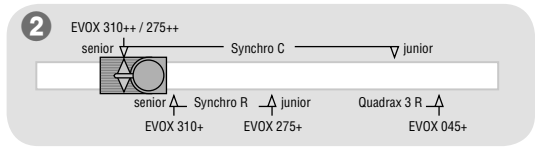

Adjustable Retail Jigs

Place the jig on a flat surface.

Open the locking lever.

Extend the jig to accept the boot.

Place the toe of the boot sole against the toe guide.

Slide the heel guide snugly against the boot heel. **Fig. 1** If the boot is too long for the jig, refer to **Jig Use With Extra Long Boot Soles** below.

Close the locking lever.

Compare the mid-sole mark on the boot with the mid-sole indicator

on the jig. If the two agree, remove the boot and use the mid-sole indicator to center the jig on the ski. Otherwise leave the boot in the jig to position it on the ski.

Adjustable Rental Jigs

Place the jig on a flat surface.

Open the locking lever.

Determine the Jig Adjustment Setting to use (refer to the **Rental Jig Adjustment Setting Chart**).

Extend or contract the jig until the size indicator aligns with the correct Jig Adjustment Setting.

Fig. 2

Close the locking lever.

Rental Jig Adjustment Setting Chart

Binding Brand	Binding Models	Visual Indicator Range	Boot Sole Range (mm)	Jig Name	Adjustment Setting
Atomic	FFG 12 ++	4 to 12	260-382	Rental	Synchro C Senior
Salomon	Z12 SC	4 to 12	260-382	Rental	Synchro C Senior
Salomon	Z10 SC	3 to 10	260-382	Rental	Synchro C Senior
Salomon	L10 SC	3 to 10	260-382	Rental	Synchro C Senior
Salomon	L10 SR	3 to 10	268-348	Rental	Synchro R Senior
Salomon	L7 SR	2 to 7.5	230-308	Rental	Synchro R Junior

Jig Positioning

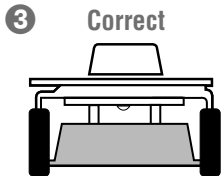

Place the skis on the workbench with the ski tips pointed to your left. The labelling on the jigs is oriented in this way.

Open the jig by twisting both handles inward.

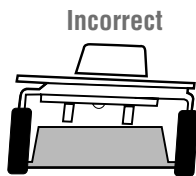

Place the jig on the ski. **Fig. 3** If the ski has a mid-sole mark, align the mid-sole mark on the boot with the mid-sole mark on the ski.

- If the ski has a tip-of-boot mark, align the tip-of-boot sole indicator on the jig with the tip-of-boot mark on the ski.
- If the ski has no visible markings for jig location, consult the ski manufacturer for proper mounting position.

Release the handles simultaneously once in position and the jig will center itself on the ski. **Note:** some jigs come with reversible/changeable pads on the clamp feet which can be re-configured based on the

width of the ski. (See **Reversible Pads** below.)

Remove the boot if it was retained for jig-centering purposes.

Re-check your work. The ski is now ready to be drilled using the correct hole pattern.

Note: Customers may request that specific mounting positions. Consult ski manufacturer's recommendations for mounting positions. Make a note on the Workshop Form to record such requests.

Drill Hole Pattern Selection

Many jigs come with multiple hole patterns that allow for multiple applications. Be sure to identify the correct hole pattern corresponding to the binding or interface plate before drilling.

Easytrak Drill Hole Pattern Chart

Binding Brand	Binding Models	Visual Indicator Range	Boot Sole Range (mm)	Jig Name	Hole Pattern to Drill
Atomic	XTE 10 ++	3 to 10	273-380	Easytrak	Large
Atomic	XTE 7 ++	2 to 7.5	229-336	Easytrak	Medium
Atomic	XTE 045 ++	0.5 to 4.5	197-304	Easytrak	Small
Salomon	L7 Easytrak	2 to 7.5	229-336	Easytrak	Medium
Salomon	C5 Easytrak	0.5 to 4.5	197-304	Easytrak	Small

Reversible Pads

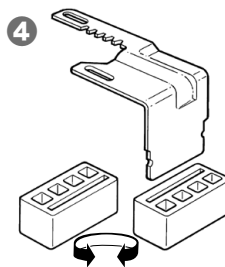

Reversible pads adapt jigs to different widths of skis. The pads are changed by pulling them off the jig and repositioning them to achieve the desired width. **Fig. 4** Some jigs are supplied with multiple sizes of pads, allowing an even wider range of ski widths to be supported. **The pads are properly positioned when they touch the jig shoulder.**

INSTALLATION (continued)

Jig Use With Extra Long Boot Soles

Occasionally a boot sole is too long to fit a jig. In this instance, the following procedure should be used to allow correct mounting of the binding:

Open the jig to its fully extended position.

Place the boot heel into the jig against the heel guide.

Measure the length of the sole that extends over the toe arrow (viewed from the underside) of the jig.

Divide this length in half (measurement A).

Place the fully extended jig onto the ski with the boot mid-sole mark aligned with the mid-sole mark on the ski.

Move the jig forward of the mid-sole the same distance as measurement A and drill the toe holes.

Re-align the jig's mid-sole mark to the ski's mid-sole mark. Move the jig backwards from the mid-sole mark the same distance as measurement A and drill the heel holes.

Install the bindings. (Verify that screw penetration will not exceed hole depth.)

Drilling, Tapping & Glue

Drilling

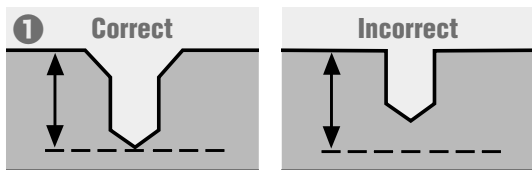

For drilling and tapping and gluing skis, follow the recommendations of the ski manufacturer. The **Drilling, Tapping and Glueing Guide For Atomic and Salomon Skis** can be found on **page 44**. For other skis, follow the recommendations of the ski manufacturer. In their absence, you may use the **General Drill Bit Selection Guide (below)**. When in doubt about the ski's core composition, select a 3.6 mm diameter bit and drill one hole. If the bit comes in contact with any metal, re-drill with a 4.1 mm bit to ensure proper screw retention.

Drill through the jig's proper bushings applying moderate downward pressure on the drill. Verify that the countersink bevel on the drill bit has properly de-burred the hole. **Fig. 1** After drilling, turn the ski over and hit the base several times with the palm of your hand to remove any debris from the drilled holes.



Special Cases When Drilling Thin or Junior Skis

When mounting thin skis or junior skis with adult bindings you may need to use shorter screws or add washers to the existing screws between the binding and the ski to prevent damaging the ski base. Before drilling any junior ski, check the screw depth by positioning the binding over the mounting area so that the binding screws on one side of the heel track appear alongside the ski sidewall.

Fig. 2

Whenever junior bindings are mounted on adult skis, an increased possibility exists of binding pull-out due to poor screw retention. The penetration depth of junior screws into the ski core is only 6 mm. If necessary, use adult drill bits and screws to penetrate any mounting platform.

The hole must be deep enough to accommodate the screw length you are using or ski damage may result.

General Drill Bit Selection Guide

Skis	Diameter	Length	Ref.	Aspect
Junior (Ski Group 3 & 4)	4.1 mm (ski with metal)	8 mm	000813 1 x 5	
	3.6 mm (ski with no metal)	8 mm	000814 1 x 5	
Adult (Ski Group 1 & 2)	4.1 mm (ski with metal)	9.5 mm	000893 1 x 5	
	3.6 mm (ski with no metal)	9.5 mm	000892 1 x 5	

Tapping

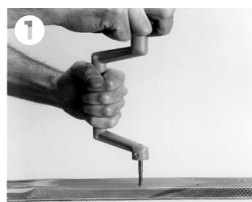

Unless otherwise recommended by the ski manufacturer, tap all binding mounting holes. Failing to tap when necessary can result in topskin delamination, sidewall delamination, broken screws or damage to the ski core.

The tap should be mounted into a brace. Position the brace so the tap goes straight into the drilled hole. **Fig. 1** Apply only enough pressure to the brace to start the tap, as the tap is a self-cutting tool.

A ski mounting plate is usually no more than 8 mm below the topskin. Tapping any deeper than 8 mm can strip the hole or break the tap. Each full turn of the brace cuts the tap approximately 2 mm into the ski. After tapping, turn the ski over and hit the base several times with the palm of your hand to remove shavings from the hole.

Note: The **Drilling, Tapping and Glueing Guide For Atomic and Salomon Skis** can be found on **page 44**.

PARTS (see page 48)

Reference #	Item Name
AZD000068	Rental Jig Atomic
L00100300	Rental Jig Salomon
AZD000076	Wide Rental Jig Atomic
L00104000	Wide Rental Jig Salomon
L30863000	Easytrak Jig

INSTALLATION (continued)

Drilling, Tapping & Glue (continued)

Glue

Glue must be used when inserting binding screws to:

- Lubricate the screw during insertion. Place a drop of glue on the surface of each hole. As the screw passes through the glue it coats itself.
 - Create a watertight seal.
 - Ensure that the screws will hold while the ski is in use by acting as a dampener.
- Caution:** Certain adhesives may adversely affect the composition of skis.

The recommended glue for Atomic and Salomon skis can be found in the **Spare Parts Catalog (page 48)**

REFERENCE

Page #	Section Name
10	Jig Selection & Use

PARTS (see page 48)

Reference #	Item Name
L00081800	Black Plastic Plugs
L00081100	Glue
L00086200	Posidrive Screwdriver
AZD000046	Posidrive Bit Atomic

Mounting

A Posidrive No. 3 screwdriver, not a Phillips, is used to mount Atomic and Salomon bindings. Consult the **Spare Parts Catalog (page 48)** for reference on Atomic and Salomon screws. They are available through your customer service representative.

General Retail Mounting



All Atomic and Salomon bindings feature the E-Z Mount System with the screws already in place. Position the component over the prepared holes to begin installation (**Fig. 1**). If a power screwdriver is used, adjust the clutch

for the appropriate ski core construction. Hand check each screw after mounting.

LEGEND – RETAIL MODELS

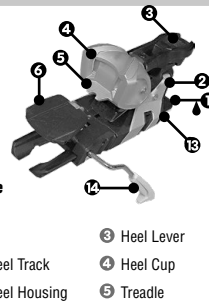
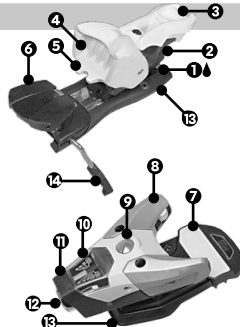
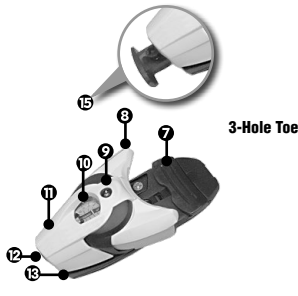

- 10 Visual Indicator
- 11 Housing
- 12 Visual Indicator Adjustment Screw
- 13 Baseplate
- 14 Brake Arm
- 15 Center Mounting Hole Sliding Track
- 6 Brake Pedal
- 7 AFD
- 8 Toe Cup
- 9 Toe Height Adjustment Screw
- 3 Heel Lever
- 4 Heel Cup
- 5 Treadle
- 1 Lubrication Point

Toe Piece

Toe Installation differs for 4-hole toe and 3-hole toe bindings. The former requires a criss-cross screwing pattern while the latter starts with a center mounting hole sliding track beneath the front of the toe.



4-HOLE TOE INSTALLATION

A long bit is needed to mount the 4-hole pattern toes as the front two screws must be inserted through the binding housing. **Fig. 2**

Use a crisscross screwing pattern and insert each screw until nearly seated. **Fig. 3** Do not tighten until all the screws are in place.



The baseplate of the AFD should be flush with the topskin of the ski and each screw should be flush with the baseplate of the toe piece. This procedure applies for all toe pieces with a four-hole pattern.



3-HOLE TOE INSTALLATION

For models with a 3-hole pattern, first pull the center mounting hole sliding track out from the binding far enough to insert the screw into the ski. A long bit is needed **Fig. 4**

Tighten the screw until it is firmly seated. Next, slide the toe piece towards the seated center screw until

the two rear screws align with their respective holes.

Tighten the rear screws until they are firmly seated. The base plate should be flush with the topskin of the ski and the head of each screw should be flush with the baseplate.

INSTALLATION (continued)

General Retail Mounting (continued)

Heel Piece

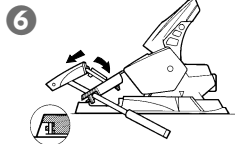

Place the heel over the prepared holes and insert the screws using a crisscross screwing pattern. (Do not compress the ski brake before it is mounted on the ski.) **Fig. 5** Do not over tighten.

Ski Brake

Do not compress the ski brake before installing it. Place the two metal tabs on the front of the brake into the slots in the heel base plate **Fig. 6**. Rotate the rear of the brake downwards to start the screw in the track. Tighten screws with a hand screwdriver (4 N-m maximum). For Backcountry and STH² models refer to the specific instructions on **page 21**.

Note: Some brakes can be removed to facilitate ski maintenance. To remove these brakes, turn the center screw counterclockwise and remove the brake.

General Rental Mounting

There are two basic types of Rental/Demo bindings: fixed toe and moveable toe. Moveable toe models allowing both the toe and heel piece to be adjusted to "center" the boot on the ski. Fixed to models allow only the heel to be adjusted.

For other rental/demo models such as the Z-Speed and Easytrak please refer to model-specific instructions starting on **page 17**.

LEGEND – RENTAL MODELS

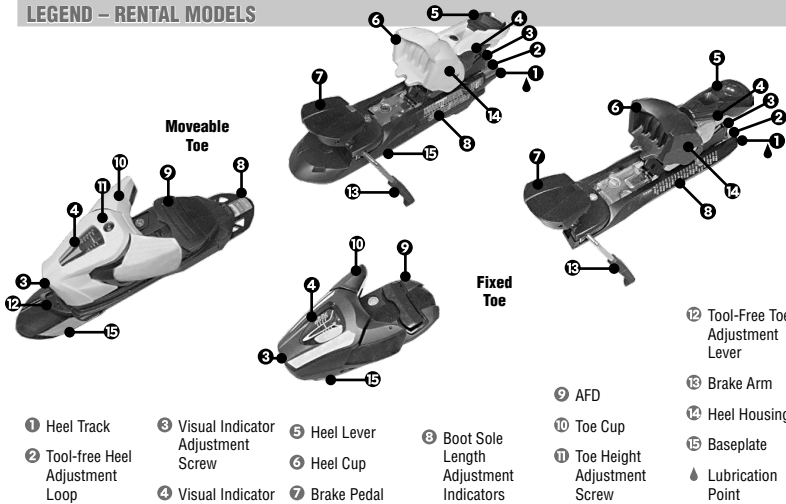

REFERENCE

Page #	Section Name
12	Drilling, Tapping & Glue
15	Binding-to-Boot Adjustments
38	Maintenance and Repairs

PARTS (see page 48)

Reference #	Item Name
L00090500	Grease Salomon
L00086200	Posidrive Screwdriver
AZD000046	Posidrive Bit Atomic
AZD000066	Adult Retail Jig Atomic
L00115600	Adult Retail Jig Salomon
AZD000068	Rental Jig Atomic
L00100300	Rental Jig Salomon
AZD000076	Wide Rental Jig Atomic
L00104000	Wide Rental Jig Salomon
L00090200	Adjustment Tool Salomon (Flat Blade)

Atomic Rental/Demo and Salomon Synchro Systems



Fixed toe models (Atomic + and Salomon SR) are mounted using the Retail procedures.

Moveable toe models (Atomic ++ and Salomon SC) are mounted using the following procedure.

First, adjust the jig to the proper position corresponding to the model of binding being installed. It is im-

perative that the jig be set correctly and all bindings be mounted at the correct position otherwise the adjustment range indicators will not be properly calibrated. For consistent mounting, drill the jig and pin it in the correct position.

Next, place the jig properly on the ski, drill the ski and remove any shavings. Place a drop of glue onto the drilled holes. On moveable toe model bindings, mount the toe plate securely with the four screws provided **Fig. 1**. Move the Tool Free toe

adjustment lever on the front of the toe to the left and slide the toe onto the plate **Fig. 2**.

Slide the range indicator plate forward onto the toe piece, **Fig. 3**.

Position the heel over the drilled holes, **Fig. 4** and tighten using a crisscross pattern.

BINDING-TO-BOOT ADJUSTMENTS

Binding-to-Boot adjustment involves four general steps: **Initial Positioning**, **Forward Pressure Adjustment**, **Toe Cup Width Adjustment**, and **Toe Height Adjustment**. By the end, the goal is to have the boot held in place by the binding with the appropriate pressure and contact points.

Initial Positioning



Moveable Toe Models

Start by making sure the toe piece is in the correct position. Move the button on the front of the toe to the left, and slide the toe to the appropriate position. **Fig. 1** Ensure the toe locks firmly in place. For non-current moveable toe models, push the toe back, depress the button on the left side of the toe, and slide the toe into position. The toe locks into place automatically.

Moveable Heel Models

If the heel position is adjustable, adjust it to the initial position now. For Rental, Easytrak and Smartrak systems, this means moving the heel until it locks into the position corresponding to the intended boot sole length. Other models require placing the toe of the boot into the open binding and moving the heel piece forward or backwards until the binding heel cup contacts the heel of the boot.

All Models

Insert the boot in the binding. In order to accurately adjust forward pressure, first check that the tip of the boot sole is flush against the butt plate of the toe piece (or central roller of applicable models). For models with manual toe wing and height adjustment, this may require a temporary loosening of the toe height and toe wings to avoid forcing the boot backwards.

Heel Position / Forward Pressure

All forward pressure adjustments should be verified with the boot in the binding (closed position). Atomic and Salomon bindings use a variety of forward pressure adjustment mechanisms, though two main patterns exist: Adjustment Tab Models (bindings with a range indicating the correct forward pressure) and Micro Metric Models (bindings that allow for a precise adjustment using a dedicated screw).

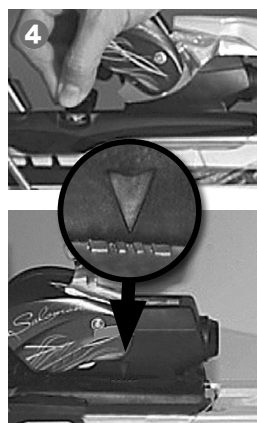
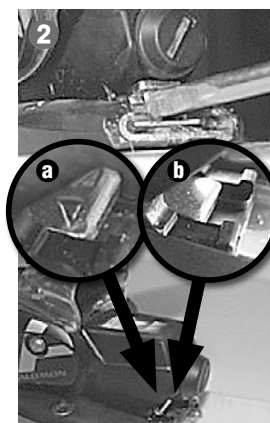

Adjustment Tab Models

- The forward pressure is correct:
- when the arrow on the adjustment tab (or back edge of the adjustment tab for models since 2009/2010) lines up within the scribed area at the end of the heel housing (**Fig. 1 and 2**);
 - when the arrow (indicator) of the rear of the heel housing lines up within the scribed area (range) on the adjustment tab (**Fig. 3**) or heel track (**Fig. 4**);

- when the silver indicator tab is within the visible range of the housing window on Atomic +/+ and Salomon Synchro models (**Fig. 5**)

If the adjustment is incorrect, remove the boot from the binding, lift the adjustment tab*, lever or loop and slide the heel to the desired position. Re-insert the boot and check the adjustment.

*The adjustment tab for certain retail models requires the use of a flat blade screwdriver.

Z-Speed models: forward pressure adjustment instructions can be found on **page 17**.



BINDING-TO-BOOT ADJUSTMENTS (continued)

Heel Position / Forward Pressure (continued)

Micro Metric Models

With the boot in the binding (closed position), turn the Forward Pressure Adjustment Screw either clockwise or counter-clockwise, until the top of the screw head aligns with the back of the heel track (Fig. 6) or heel housing (Fig. 7).

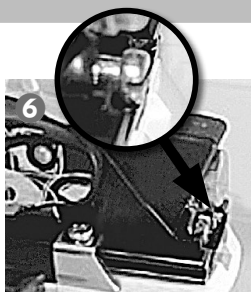

Toe Cup Width Adjustment

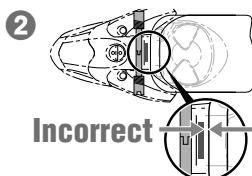
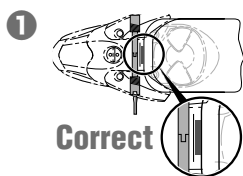

Independent Wing Adjustment Models.

The adjustment screws for models with independent wing adjustments are located on each side of the toe piece. Adjust each wing snugly against the boot sole so that the boot is centered over the ski. **Fig. 1 Do not over tighten Fig. 2** as it forces the boot backward, increasing the forward pressure. When properly adjusted, the toe contacts the boot sole at three points: the butt plate and the low friction inserts in each wing arm.

Simultaneous Wing Adjustment Models.

The adjustment screw for models with simultaneous wing adjustments is located on the left of the toe piece. **Fig. 3** By turning this screw, both toe wings adjust simultaneously. Adjust the wings snugly against the boot sole. **Do not over tighten.** The toe cup adjustment is correct when there are three points of contact: the butt plate and the low friction inserts on each wing arm.

Automatic Wing Adjustment Models.

No toe cup width adjustment is necessary for automatic wing adjustment models. Some junior model bindings adjust automatically to accept either children's or adult norm boots. (The added width of an adult norm boot sole somewhat limits the shock absorption capability of bindings that can be used with both junior and adult norm boot soles. It is suggested that aggressive junior skiers with an adult norm boot sole use a model designed exclusively for adult norm boots.)

Toe Height Adjustment

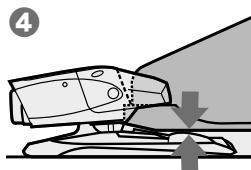

All Atomic and Salomon binding models must have a clearance of 0-0.5 mm between the AFD and boot toe. **Fig. 4**

Automatic Height Adjustment Models.

No toe height adjustment is necessary for automatic toe adjustment models.

Manual Toe Height Adjustment Models.

Raise the toe by turning the adjustment screw, located on top of the toe piece, counterclockwise. Pull the boot back to create a gap between the boot sole and the binding AFD. Adjust the toe height to create a gap of not more than

0.5 mm or until the boot sole just touches the AFD. You can use a 0.5 mm Toe Height Adjustment Card to gauge this clearance **Fig. 5-6. Do not over tighten.**

Always re-check the forward pressure adjustment after making any toe height or wing adjustments.

REFERENCE

Page #	Section Name
25	Release Value Selection & Adjustment
39	AFD Replacement

MODEL-SPECIFIC INSTRUCTIONS

Salomon Z Speed

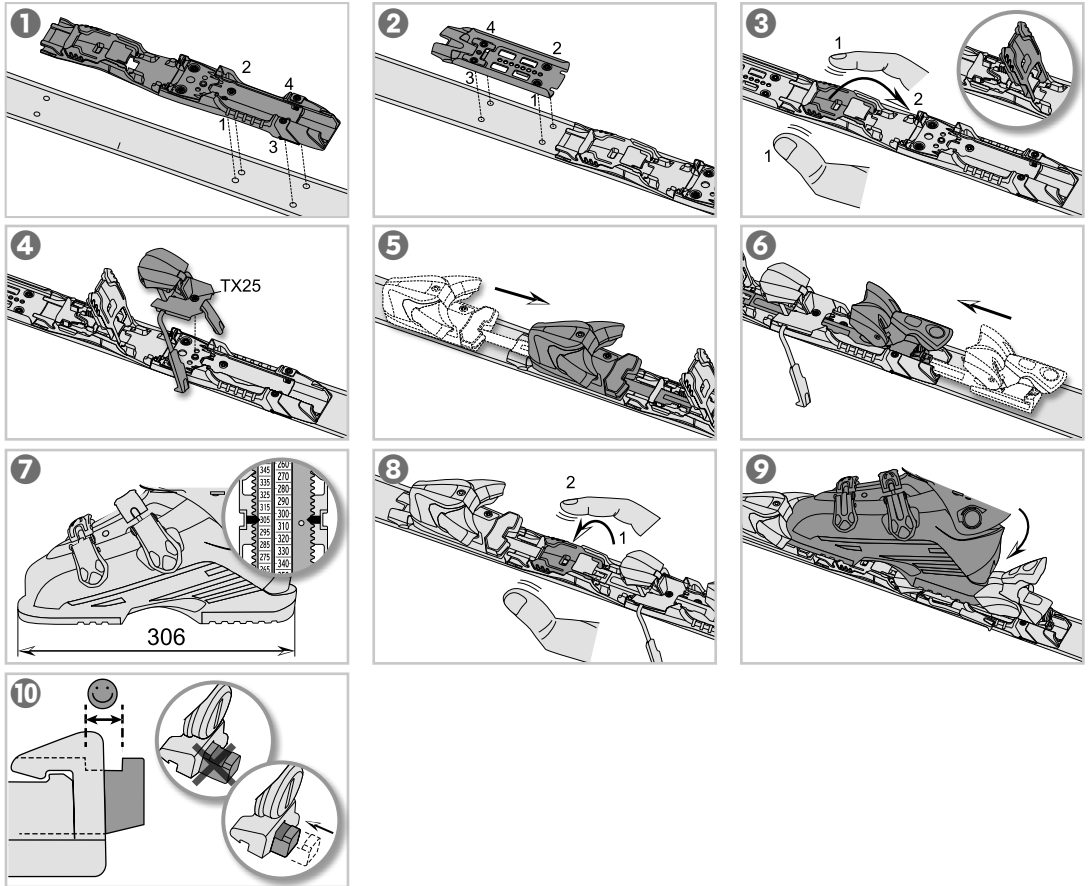
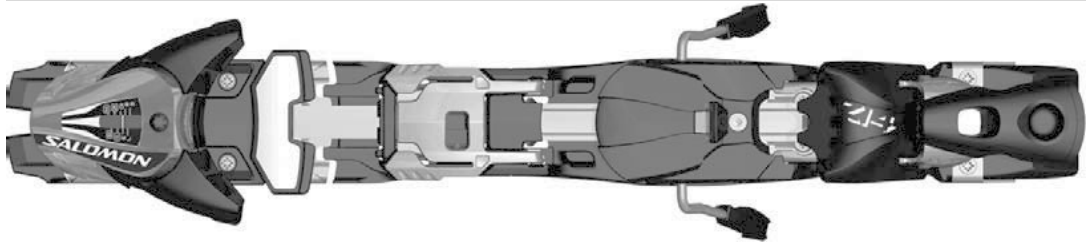

Salomon Z Speed Installation

For mounting Z Speed bindings on skis, holes have to be drilled with the Z Speed mounting jig (Ref. #L11139300) to ensure a proper alignment of the binding. All screws should be tightened using 4 N·m of torque.

Mount the rear and front plates by tightening the screws in a criss-cross pattern. **Fig. 1-2**

Pinch and open the central lock lever. **Fig. 3**

Mount the brake in the usual manner using a Torx 25 bit. **Fig. 4**

Slide the toe piece onto the track from the front backward and the heel piece from the tail forward. **Fig. 5-6**

Determine the boot sole length in mm.

Adjust the toe and heel pieces until values in the centre click into a position corresponding with the boot sole length. **Fig. 7**

Close and lock on the central lever. **Fig. 8**

Insert the boot and check the forward pressure. **Fig. 9-10**

PARTS (see page 48)

Reference #	Item Name
L11139300	Z Speed Jig

MODEL-SPECIFIC INSTRUCTIONS (continued)

X 12 VAR, X 16, and X 20 Bindings

To be mounted by an Atomic or Salomon Authorized Dealer only.

NOTE: The Atomic X-12 without VAR technology uses the procedures outlined on the NEOX / X12 Model Specific Page.

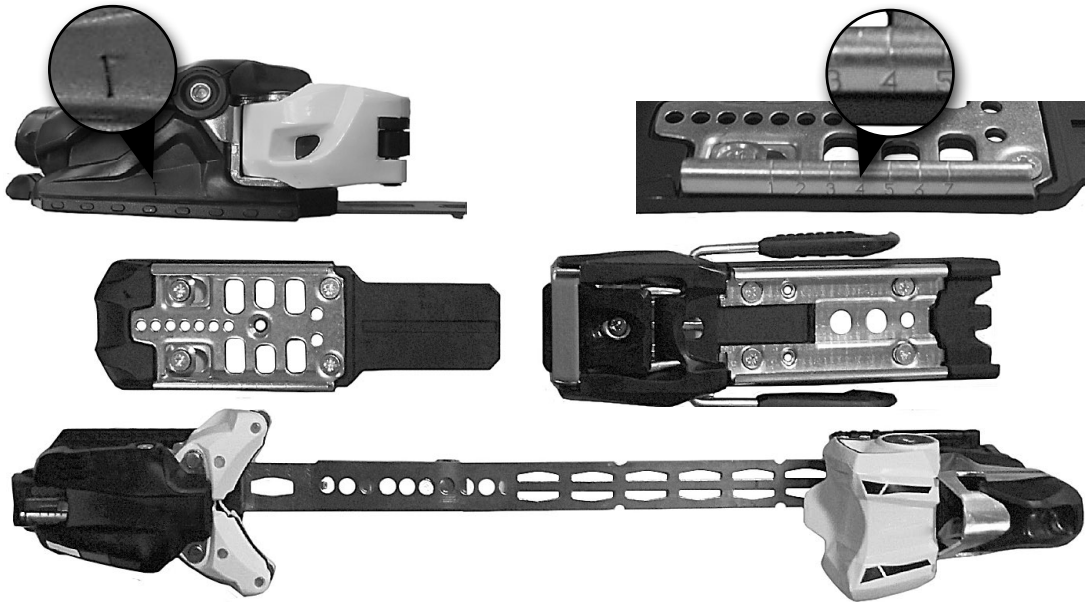

Drilling

Holes have to be drilled with the X Binding mounting jig (Ref. #AZD00084) to ensure a proper alignment of the binding.

Check the boot sole length you would like to mount the binding for and drill the "S"; "M" holes which are marked on the jig following the instructions in the **X 12 and X 16 Mounting Position Chart** to the right.

Drill your chosen setup and remove the mounting jig.

Note: The X 12 & X 16 bindings have an additional hole in the middle to attach the brake. Don't forget to drill this hole.

X 12 and X 16 Mounting Position Chart

Sole length (mm)	Mounting of Heel rail	Mounting of Toe rail	Toe piece position on the toe rail	Bootcenter relative* to the actual bootcenter (mm)	Maximum of positions to adjust the boot center +/-	
					Forward	Backward
265	"S"	"M"	Position 7	+ 7.0 mm	+2	0
275	"S"	"M"	Position 7	+ 2.0 mm	+2	-1
285	"S"	"M"	Position 7	- 3.0 mm	+3	-1
295	"S"	"M"	Position 6	- 0.5 mm	+4	-1
305	"S"	"M"	Position 5	+ 2.0 mm	+1	-2
315	"M"	"M"	Position 5	- 3.0 mm	+3	-1
325	"M"	"M"	Position 4	- 0.5 mm	+2	-1
335	"M"	"M"	Position 3	+ 2.0 mm	+3	-1
345	"M"	"M"	Position 3	- 3.0 mm	+2	-1
355	"M"	"M"	Position 2	- 0.5 mm	+2	-1
max 360	"M"	"M"	Position 2	- 3.0 mm	+2	0

* Forward = "+" Backward = "-"

Mounting

Mount the toe and heel base plates by tightening the screws using 4 N-m of torque.

Mount the brake in the usual manner.

Push the "VAR" lever over to the right and slide the toe piece from the middle towards the tip of the ski.

Move the toe piece to the number corresponding to the boot sole length you would like to mount the binding for.

Slide the heel piece from the tail forward.

Match up the steel band with the boot sole length you would like to mount the binding for.

Take the "AFD" pedal and place it in the middle and tighten the screw using 4 N-m of torque.

Put the boot into the binding and check the forward pressure. The screw head needs to be aligned with the housing.

PARTS (see page 48)

Reference # Item Name
AZD00084 X Binding Jig

MODEL-SPECIFIC INSTRUCTIONS (continued)

Atomic NEOX & X12 (non VAR) Bindings

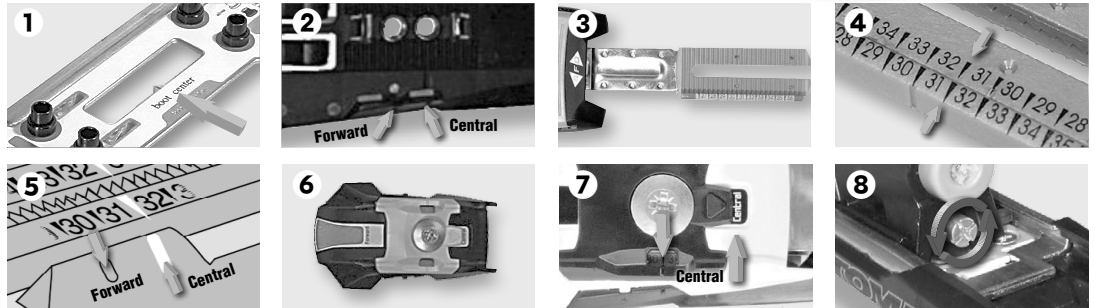
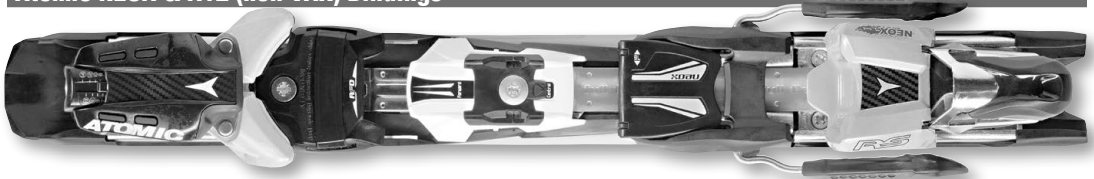

Base Plate Mounting

Measure the boot sole length.
Attach the Atomic Neox Mounting Jig (Ref.# AZD000086) to the ski. The jig follows the pattern for Fixed Jigs, as described in **Jig Positioning** and **Drill Hole Pattern Selection** (on page 11) as well as

Drilling, Tapping and Glueing (on page 12). The "boot center" indicator on the jig (Fig. 1) is used to align it to the center of the ski. The two Neox hole patterns to use on the jig correspond to boot sole lengths that are either less than or greater than 340 mm.

Drill the holes using a consistent drilling pattern with a drill bit appropriate for the ski.*
Follow tapping and glueing procedures according to the ski manufacturer's recommendations.

Mount the toe and heel base plates on the ski by hand-tightening the screws using 4.5 N-m of torque in a criss-cross pattern starting near the center.

Binding Mounting

Determine the boot position requested by the customer. Neox bindings offer two mid-sole positions for mounting the toe and heel pieces – either Central or Forward.** The Central Position is indicated on the toe base plate, lining up with the hole closest to the center of the ski. The Forward Position indicator mark is smaller and about a centimeter ahead of the center, next to a second hole (Fig. 2). Whichever position is chosen, it will be used to align the toe and heel pieces in the remaining steps and the corresponding hole will be used to attach the Position Cap. Both toe and heel pieces have an array of numbers printed at the

tip of their centering bands that correspond to the length of the boot in centimeters (rounded to the nearest 5 mm) (Fig. 3).
Slide the toe piece onto the track of the front base plate from the tip of the ski backwards until the number corresponding to the boot length near the end of the steel spacing band lines up with the chosen Central or Forward Position. Press down to make sure that the locking teeth line up.
Make sure that the AFD clicks into place in the guides of the toe base plate. On pre-mounted systems the AFD Plate may need to be mounted.

Doing so requires using 4.0 N-m of torque.
Remove the ski brake lock.
Slide the heel piece onto the rear base plate from the tail of the ski forward, allowing the steel band to pass beneath the brake, until the boot length indicator lines up above the same length value on the toe piece centering band (Fig. 4). The matched length values should line up with the chosen Central or Forward Position indicator on the base plate (Fig. 5), and the locking teeth on all three pieces should fit together.

Clip the Sole Length Cover (Fig. 6) over the intersecting centering bands, place the Position Cap over it so that the indicator marking aligns with the requested Central or Forward mid-boot Position (Fig. 7) and tighten the Locking Screw using 4.0 N-m of torque.

NOTES

- * Drilling: depths of drill holes under 9 mm are marked on skis. For drilling holes in VOLANT-skis only ATOMIC-step drills of a length of 4.5 mm may be used.
- ** Central Position (standard position): better steering control.
 Forward Position: easier turn initiation and turning.

REFERENCE

Page #	Section Name
10	Jig Selection & Use
12	Drilling, Tapping & Glue
25	Release Value Selection & Adjustment
25	Requested Settings

PARTS (see page 48)

Reference #	Item Name
AZD000086	Atomic Neox Jig

Binding-to-Boot Adjustment

Proceed with Binding to boot adjustments. The NEOX has an Automatic Toe Height Adjustment within the 19 mm ±1.5 mm range. Forward pressure follows the **Micro Metric Forward Pressure**

Adjustment pattern as described on page 16, however adjustments must be made by first removing the boot from the binding. Once the Forward Pressure Adjustment Screw (Fig. 8) has been turned, the

boot should be placed back in the binding to re-check. Forward pressure is correct when the Forward Pressure Adjustment Screw head is flush with the back of the heel housing.

MODEL-SPECIFIC INSTRUCTIONS (continued)

WTR Technology



Walk-To-Ride (WTR) technology was developed to offer skiers a boot and binding system that provides the walking ease and comfort of a touring boot combined with the confidence and performance of a traditional alpine set-up.

Binding-to-Boot Compatibility

Boots equipped with WTR technology soles are compliant with the

international standard for touring ski boots (ISO 9523) and are also compatible with WTR technology alpine bindings.

WTR Bindings are compliant with the international standard for alpine ski bindings (ISO 9462) and are also compatible with boots equipped with WTR technology soles.

Mounting and Adjusting Procedures

Procedures for mounting and adjusting WTR bindings are consistent with all procedures in this manual. This applies to boots equipped with alpine soles (ISO 5355) and boots equipped with WTR technology soles.

Warning

WTR technology bindings (Guardian, Tracker, and STH²) are intended to be used only with the following ski boots:

- Alpine Ski Boots compliant with ISO standard 5355
- Ski Boots with WTR certified soles.

Any use with other boots could affect release characteristics, which may increase the risk of injury while skiing.

Any use of boots other than those compliant with ISO 5355 or those with WTR certification is not

recommended, and any results from a mechanical inspection may not be reliable.

Skiers are advised to consult their authorized Salomon dealer for further information regarding which boot and binding system is appropriate for their needs.

Skiers who choose to use boots other than those compliant with ISO 5355 or those with WTR certification should be informed of the potential risk.

Mounting Backcountry Bindings Featuring WTR Technology

To be mounted by an Atomic or Salomon Authorized Dealer only.

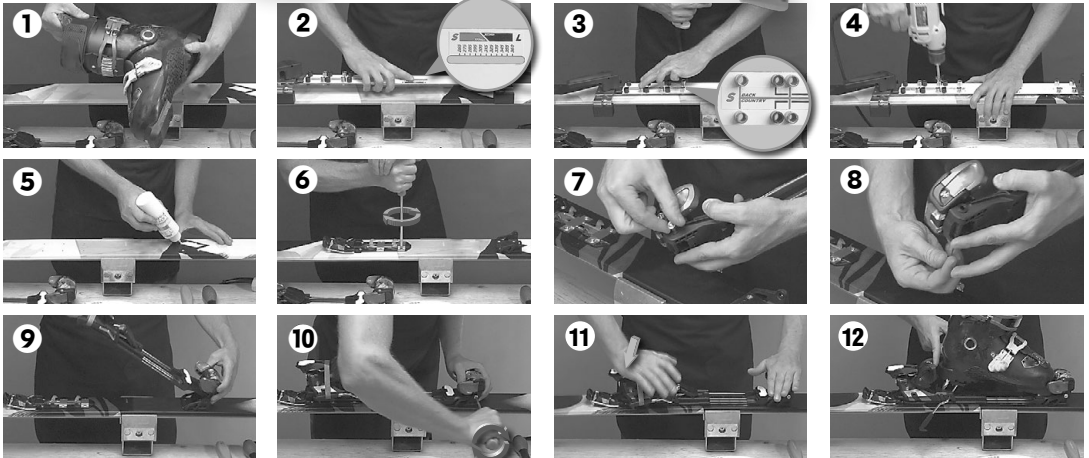
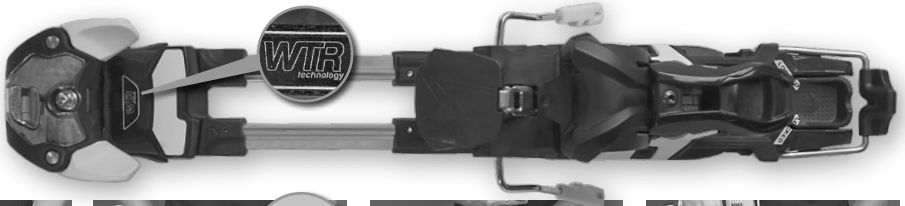

Check the boot sole length (Fig. 1).

Attach the Backcountry Mounting Jig (Ref. # L32670500) using the boot sole length as indicated in the central window on the jig to align it to the center of the ski (Fig. 2).

Determine the set of holes to use on the jig corresponding to the binding model (either Small or Large) (Fig. 3).

Drill the holes using a consistent drilling pattern with a drill bit appropriate for the ski (Fig. 4).

Follow tapping and glueing procedures according to the ski manufacturer's recommendations (Fig. 5).

Mount the toe base plate and the step-in heel base plate by tightening the screws in a criss-cross pattern using 4 N-m of torque (Fig. 6).

Remove the plastic piece which holds the pivot screw and remove the screw from the toe piece (Fig. 7-8).

Align the toe piece with the pivot point on the toe base plate (Fig. 9).

Insert the pivot screw and tighten it with a Posidrive screwdriver using between 2 and 4 N-m of torque (Fig. 10).

Press down on the heel to engage the lock on the Hike-and-Ride switch. When properly engaged, the text across the surface of the Hike-and-Ride switch should be aligned (Fig. 11).

Place the boot in the open binding and either tighten or loosen the forward pressure adjustment screw using a Posidrive screwdriver until the

binding heel cup contacts the heel of the boot (Fig. 12).

REFERENCE

Page #	Section Name
10	Jig Selection & Use
12	Drilling, Tapping & Glue
25	Release Value Selection & Adjustment
25	Requested Settings
PARTS (see page 48)	
Reference #	Item Name
L00090200	Adjustment Tool Salomon (Flat Blade)
L32670500	Backcountry Jig

MODEL-SPECIFIC INSTRUCTIONS (continued)

Mounting Backcountry Bindings Featuring WTR Technology (continued)

Adjusting Forward Pressure and Toe Height



Step in the boot (Fig. 1) and adjust the heel piece's position with a Posidrive screwdriver until the forward pressure is correct (Fig. 2). Forward pressure is correct when



the forward pressure adjustment screw head is flush with the back of the heel housing (Fig. 3) yet still within the Adjustment Area indicated on the heel track (Fig. 4).



Adjust the toe height by turning the toe height adjustment screw while using a toe height card to obtain a 0.5 mm gap between the boot sole and the binding (Fig. 5).

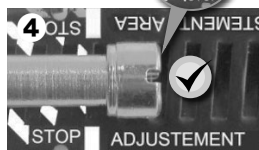

Ski Brake Replacement



Refer to the Spare Parts Catalogue to know which brake corresponds to the ski width and binding model being used.

Remove the boot if it is in the binding (Fig. 1).

Turn the forward pressure adjustment screw at the back of the heel housing clockwise (Fig. 2) until the screw head

is past the Adjustment Area and the heel piece can slide forward freely (Fig. 3).

Release the Hike-and-Ride switch (Fig. 4) to allow the heel piece to slide forward completely off the track (Fig. 5).

Pivot the ski brake to separate it from the heel piece (Fig. 6).

Insert the two plastic tabs on the new ski brake into the slots provided at the front of the heel housing (Fig. 7) and attach the brake to the heel piece (Fig. 8).

Slide the complete heel piece onto the heel track from the front backwards (Fig. 9).

Re-engage the Hike-and-Ride (Fig. 10).

Turn the forward pressure adjustment screw counter-clockwise while pushing back on the heel piece until the screw head is back within the Adjustment Area indicated on the heel track (Fig. 11).

Re-adjust the forward pressure and toe height (Fig. 12).

Hiking Mode > Skier Instruction & Warning



Switch From Skiing Position To Hiking Position
Use your ski pole to push back on the step-in release mechanism (Fig. 1). Pivot the ski boot and heel piece forward.



Switch From Hiking Position To Skiing Position
Clear any snow, ice or dirt from the binding. DO NOT put your hand between the ski and the binding when switching to skiing position. Use the ski pole handle instead (Fig. 3). Flip back the climbing aid.



Flip forward the hiking aid using your ski pole handle to one of the two available positions: High (Fig. 2) or Low.



Step down on the binding heel piece to lock it back in place. Check that the binding is correctly locked in before skiing (Fig. 4).

MODEL-SPECIFIC INSTRUCTIONS (continued)

Mounting STH² Bindings Featuring WTR Technology

To be mounted by an Atomic or Salomon Authorized Dealer only.
For more information on WTR technology, refer to page 20.

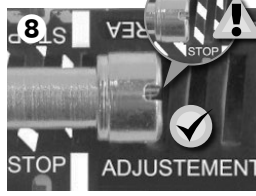
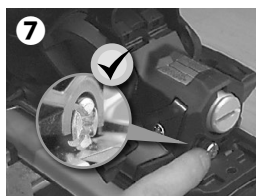
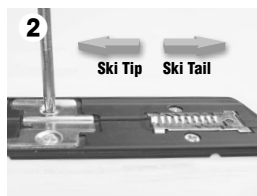
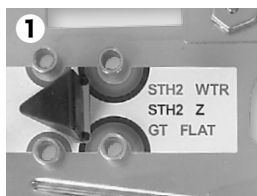

Installation and Mounting

Adjust the STH² Mounting Jig (Ref. # L32981600) following the instructions described in **Adjustable Retail Jigs** on page 10.

Drill the hole pattern corresponding to the binding model (Fig. 1), using a consistent drilling pattern and a drill bit appropriate for the ski.

Tip: The installation sequence of STH² bindings is important. The heel track and assembly must be installed before the toe piece.

Mount the rear base plate on the ski by tightening the screws using 4 N-m of torque. Be sure that the rear base is mounted in the proper orientation. The metal portion of base plate that identifies the adjustment area should be closest to the tail of the ski (Fig. 2).

Attach the ski brake to the heel piece (Fig. 3).

Slide the heel assembly onto the rear base plate from the front. (Fig. 4).

Continue moving the heel piece backwards on the track by turning the Forward Pressure Adjustment Screw with a Posidrive screwdriver (Fig. 5) until the screw head lines up with the "MID" mark located at the end of the heel track (Fig. 6).

Mount the toe piece on the ski by tightening the screws using 4 N-m of torque.

Binding-to-Boot Adjustment

Put the boot into the binding and check the forward pressure. Forward pressure is correct when the forward pressure adjustment screw head is flush with the back of the heel housing (Fig. 7) yet still

within the Adjustment Area indicated on the heel track (Fig. 8).

Perform toe cup width and toe height adjustments in the usual manner as described on page 16.

REFERENCE

Page #	Section Name
10	Jig Selection & Use
12	Drilling, Tapping & Glue
25	Release Value Selection & Adjustment
25	Requested Settings

PARTS (see page 48)

Reference #	Item Name
L32981600	STH ² Mounting Jig

MODEL-SPECIFIC INSTRUCTIONS (continued)

Smartrak System

There are two different mounting procedures for the Smartrak interface, based on the system type.

Moveable Toe Smartrak / XTO Systems (K Type Plates)



1 Insert the metal band into the recessed slots in center of plate.

Fig. 1

Determine the sole length of boot to being used.

Lift the tab behind the AFD on the toe piece and slide the toe piece from the rear of track to the front until the boot sole length number on the metal band corresponds to, or is slightly greater than, the sole length of the boot being used.



For example: a boot sole length of 306mm would require that you chose a setting on the band of 308mm. Make sure the toe piece "clicks" and locks into position on the track. **Fig. 2**

Install the heel piece by lifting the tab located just in front of the heel piece and sliding the heel assembly onto the Smartrak plate until the boot sole length number on the metal band corresponds to, or is



slightly greater than, the sole length of the boot being used. For example: a boot sole length of 306mm would require that you chose a setting on band of 308mm. Make sure the heel piece "clicks" and locks into position on the track. **Fig. 3**

Install the break in the normal manner and proceed with binding to boot adjustments as described on **page 15**.

Push the boot into the system and verify the forward pressure. Once the forward pressure is correct, the number on the metal band directly in front of the heel provides a guide to the quick positioning of the second heel.

Fixed Toe Smartrak / XTL Systems (H and J Plates)

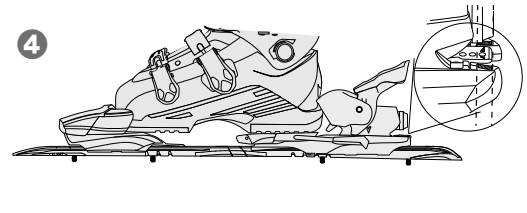
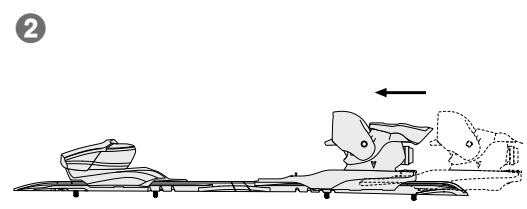
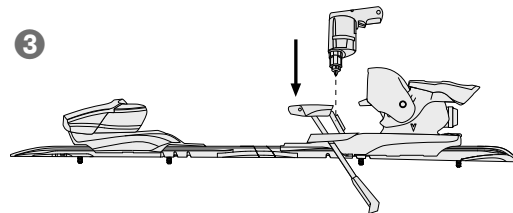
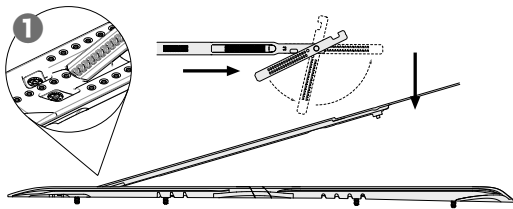

Mounting and Adjusting

Open and set the blade in straight position and place it on the plate with a rotational motion. **Fig. 1**.

Identify the length of the boot sole.

Mount the toe piece:

Identify the letter that corresponds the sole length and screw the toe

piece (if you are between two letters, choose the higher one).

Mount the heel piece:

Slide the heel piece on the interface from the rear using the manual lock to authorize the gliding. **Fig. 2**.

Mount the brake following the usual procedure. **Fig. 3**.

Position the boot in the toe and slide the heel until it touches the boot.

Step in the boot and check forward pressure, the arrow on the lock

must be within the scribed area.

Fig. 4.

Note: the rear number on the blade is an indication for a quick adjustment of the second ski.

MODEL-SPECIFIC INSTRUCTIONS (continued)

Easytrak System

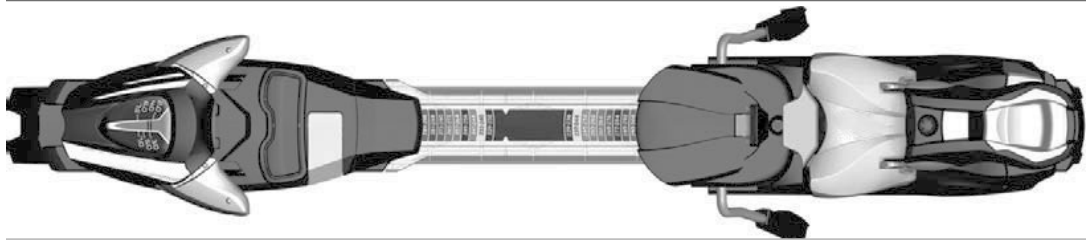

Easytrak 10, Easytrak 7, XTE 10, & XTE 7 Installation

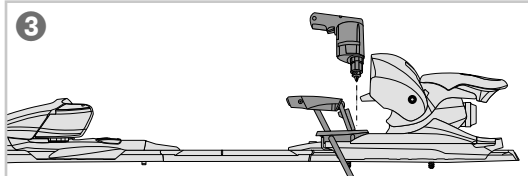
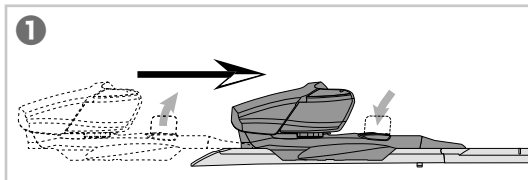

1 Slide the toe piece onto the front of the interface while holding up the manual lock until it reaches the position corresponding with the

boot sole length. Make sure the unit clicks into place. **Fig. 1**
3 Slide the heel piece onto the back of the interface while holding up

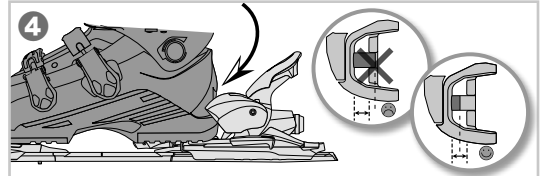
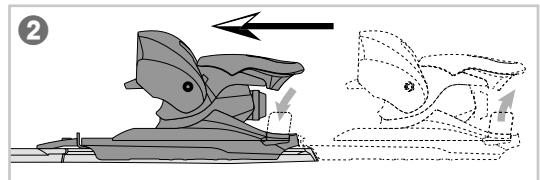

2 the manual lock until it reaches the position corresponding with the boot sole length. Make sure the unit clicks into place. **Fig. 2**

4 Mount the brake in the usual manner. **Fig. 3**
Insert the boot and check forward pressure. **Fig. 4**

Easytrak 5 & XTE 045 Installation

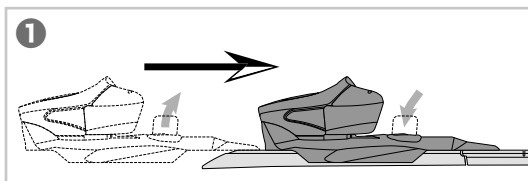

1 Slide the toe piece onto the front of the interface while holding up the manual lock until the position corresponding with the boot sole length. Make sure the unit clicks into place. **Fig. 1**

2 Slide the heel piece onto the back of the interface while holding up the manual lock until the position corresponding with the boot sole length. Make sure the unit clicks into place. **Fig. 2**

3 Insert the boot and check forward pressure. **Fig. 3**

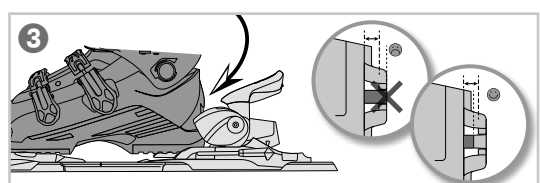
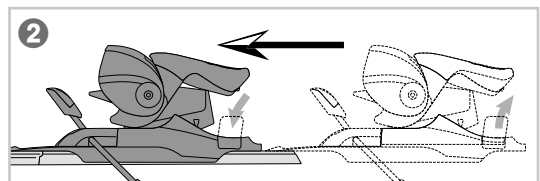

Track Position – Track position for boot sole length of 295 mm

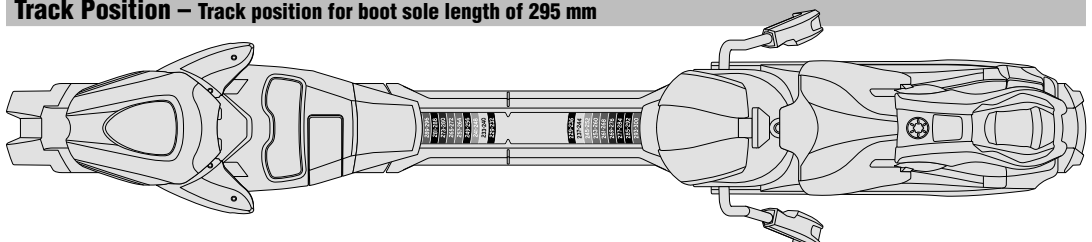

RELEASE VALUE SELECTION & ADJUSTMENT

Determining Skier Type

It is the skier's responsibility to determine Skier Type. Skier Type is not the same as skier ability and the two should not be confused. Skier Type must be indicated on the workshop form or rental form by the skier. The **Skier Classification Chart** is available in small and large poster size versions from Atomic and Salomon and should be displayed to assist customers in classifying themselves.



These descriptions are compatible with ASTM and ISO documents.

What type of skier are you?

Determining your SKIER TYPE is your responsibility! Your skier type, height, weight, age and ski boot sole length are used by the shop to determine the visual indicator settings of your ski bindings. Be sure to provide accurate information, as any error may increase your risk of injury. Consult these descriptions to select your classification:

TYPE I Cautious skiing on smooth slopes of gentle to moderate pitch

- Receive lower than average release/retention settings. This corresponds to an increased risk of inadvertent binding release in a fall.
- Type I settings apply to entry-level skiers uncertain of their classification.

TYPE II Skiers not classified as Type I or III

- Skiers who designate themselves as Type II receive average release/retention settings appropriate for most recreational skiing.

TYPE III Fast skiing on slopes of moderate to steep pitch

- Receive higher than average release/retention settings. This corresponds to decreased releasability in a fall in order to gain a decreased risk of inadvertent binding release.
- This classification is not recommended for skiers 47lb (21kg) and under.

If from experience, you have been dissatisfied with visual indicator settings resulting from your selected skier type classification, you may wish to consider: (a) changing your skier type classification; (b) selecting different skier type classifications for toe and heel components; (c) selecting skier Types -I ("for skiers who desire

visual indicator settings lower than settings for a Type I skier") or III- ("for skiers who desire visual indicator settings higher than settings for a Type III skier").

If you believe that you require higher release/retention settings, but are unsure if the increase should be applied to the toe setting (twist) or heel setting (forward lean), request that the increase be applied to the heel setting (forward lean) before experimenting with higher toe settings (twist). Similarly, if you believe that you require lower release/retention settings, but are unsure if the decrease should apply to the toe setting (twist) or heel setting (forward lean), request that the decrease be applied to the toe setting (twist) before experimenting with lower heel settings (forward lean).

Although the shop technician may help you to record your choice on the appropriate form, the final decision on your release/retention settings is yours.

Requested Settings

Skiers Requesting Settings Not Recommended by Atomic or Salomon

The **2013/2014 Atomic/Salomon Adjustment Chart** is the only release adjustment chart authorized for use by Authorized Dealers during the 2013/2014 season. It is a skier's right to choose settings outside those recommended as per the current Atomic/Salomon Adjustment Chart (particularly when the skier's preferred setting is also within the range of acceptable settings).

If the skier requests a setting other than the one derived from the current Atomic/Salomon Adjustment Chart, the shop may:

- Adjust the system to individual requests IF the technician notes on the workshop or rental form the reason the higher or lower setting was requested. The customer must verify the request for the higher or lower settings by signing and dating the form by the noted reason of the setting request. (It is suggested that the shop have the skier sign a release identical to the **Release Agreement** printed on this page. The release must then be attached to the completed workshop or rental form.)
NOTE: Current Atomic/Salomon Workshop and Rental Forms include a "Requested Settings" option for customer requested settings, which eliminates the need for a separate release in such instances.
- Adjust the system to the setting derived from the Salomon Adjustment Chart and instruct the skier on how to change the setting.

Note on Inteded Use of Competition Bindings

Atomic and Salomon distribute competition bindings to racers and coaches. These bindings are intended to be used by skiers with special retention needs. If these bindings are used by recreational skiers, there is a far greater risk of injury due to the use of more powerful springs. Refer to **Requested Settings** for instructions for skiers requesting settings not recommended by Atomic and Salomon.

Release Agreement

I, _____ hereby acknowledge that I have been advised by the

(rental shop, authorised dealer, etc.) that the setting which I have requested for my bindings (Model _____) is not the setting recommended by the manufacturer of the bindings for a skier of my height, weight, age and skier type. I understand that as a condition of obtaining this setting on the bindings at the time of their delivery, I must agree to forever release the shop, its employees and agents, the manufacturer, and the distributor from any and all liability for injury or death which results to me or others from the use of these bindings. I acknowledge that there may be increased risk of injury or death to me as a result of my own personal preference for binding setting, particularly in view of the inherent and other risks of the sport of skiing. I hereby waive all claims arising from the use of the bindings and release from all liability the shop, the distributor and the manufacturer, their agents and employees and I further agree to indemnify them from any and all liability or harm or damage of any kind whatsoever which may result from the use of these bindings by myself or anyone I allow to use the bindings.

I, the undersigned, have read and understand this liability release agreement, and agree that it is binding upon me, my heirs, guardians, administrators, assigns, and legal representatives.

Skier Signature

(or, in the case of a minor, that of the skier's parent or guardian)

Shop Manager's Signature

RELEASE VALUE SELECTION & ADJUSTMENT (continued)

2013/2014 Atomic/Salomon Adjustment Chart

All Atomic and Salomon bindings use the DIN adjustment scale. Release setting numbers on this scale are referred to as "visual indicator settings." The 2013/2014 Adjustment Chart is the only release adjustment chart authorized for Authorized Dealers during the 2013/2014 season. Only those settings recommended by Atomic and Salomon should be used when determining the appropriate adjustment for each skier's system. Refer to **Skier's Requesting Settings Not Recommended by Atomic or Salomon (page 25)** for skiers requesting other settings.



2013/2014 ADJUSTMENT CHART

Skier			Initial Toe/Heel Indicator by Boot Sole Length (mm)										Twist Forward Lean	
Weight lb/kg	Height ft-in/cm	Skier Code*	≤ 230 mm	231- 250 mm	251- 270 mm	271- 290 mm	291- 310 mm	311- 330 mm	331- 350 mm	≥ 351 mm	5	18		
22-29 lb 10-13 kg		A	3/4	3/4	3/4						8	29		
30-38 lb 14-17 kg		B	1	3/4	3/4	3/4					11	40		
39-47 lb 18-21 kg		C	1 1/2	1 1/4	1 1/4	1					14	52		
48-56 lb 22-25 kg		D	2	1 3/4	1 1/2	1 1/2	1 1/4				17	64		
57-66 lb 26-30 kg		E	2 1/2	2 1/4	2	1 3/4	1 1/2	1 1/2			20	75		
67-78 lb 31-35 kg		F	3	2 3/4	2 1/2	2 1/4	2	1 3/4	1 3/4		23	87		
79-91 lb 36-41 kg		G		3 1/2	3	2 3/4	2 1/2	2 1/4	2		27	102		
92-107 lb 42-48 kg	≤ 4'10" ≤ 148 cm	H			3 1/2	3	3	2 3/4	2 1/2		31	120		
108-125 lb 49-57 kg	4'11"-5'1" 149-157 cm	I			4 1/2	4	3 1/2	3 1/2	3		37	141		
126-147 lb 58-66 kg	5'2"-5'5" 158-166 cm	J			5 1/2	5	4 1/2	4	3 1/2	3	43	165		
148-174 lb 67-78 kg	5'6"-5'10" 167-178 cm	K			6 1/2	6	5 1/2	5	4 1/2	4	50	194		
175-209 lb 79-94 kg	5'11"-6'4" 179-194 cm	L			7 1/2	7	6 1/2	6	5 1/2	5	58	229		
≥ 210 lb ≥ 95 kg	≥ 6'5" ≥ 195 cm	M				8 1/2	8	7	6 1/2	6	67	271		
		N					10	9 1/2	8 1/2	8	7 1/2	78	320	
		O						11 1/2	11	10	9 1/2	9	91	380
		P								12	11	10 1/2	105	452
											121	520		
											137	588		

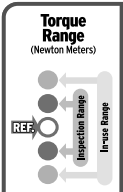

* Based on "Type I" Skier aged between 9 and 50 years old.

Determining & Adjusting Visual Indicator Settings

The following procedure is used for determining visual indicator settings using the 2013/2014 Atomic/Salomon Adjustment Chart.

- Find the Skier's Code. Locate the skier's weight and height in the first two columns. If the skier's weight and height are not in the same row, select the Skier's code that is closest to the top of the chart.
- The skier's code is appropriate for Type I skiers:
 - For Type II skiers, move down on the chart one row.
 - For Type III skiers, move down on the chart two rows.
 - For Type -I skiers, move up on the chart one row.

- For Type III+ skiers, move down on the chart three rows.
 - A skier may select different skier types for toe and heel piece.
- For skiers age 9 and younger or age 50 and older, move up the chart one row.
 - For skiers 29 lb (13 kg) and under, no further correction is appropriate.
 - For skiers 38 lb (17 kg) and under, Skier Type -I is inappropriate.
 - Locate the column that represents the skier's boot sole length (in mm).

- The box at the intersection of the skier's boot sole length column and the Skier's Code row shows the initial visual indicator setting for the skier. If the intersection of the row and column falls in a blank box, move left or right on the same row to the nearest box showing a visual indicator setting.
- Record the visual indicator settings on the Workshop Form.
 - If a skier selects different skier types for toe and heel piece, it must be recorded on the workshop or rental form in the order toe/heel (T/H), using a (/) to separate the two types.

Visual Indicator Setting Adjustment
Adjust both toes and heels of the system to the visual indicator setting derived from the adjustment chart. Sometimes a technician may experience difficulty determining exactly where the visual indicator should appear in the binding's visual indicator window. For example, a setting of 5 1/2 is not precisely marked on the binding. The technician should use those values that are clearly marked on the binding as reference points and set the release adjustment as close as possible to the setting that is recorded on the Workshop Form.

FINAL CHECKING & VISUAL INSPECTION

While anyone can mount and adjust an Atomic or Salomon binding, to receive indemnification from Amer Sports an Atomic or Salomon Certified Technician must sign or initial the Workshop Form attesting that all systems inspections have been performed. A Final Check is your quality control measure to verify that all required procedures have been properly completed.

Visual Inspection of System Components

Common Compatibility Problems

The Boot

- Inconsistencies with ISO and applicable norms.
- Gross irregularities where the boot contacts the binding and the AFD.
- Unacceptable low grade thermoplastic construction.
- Rubber and/or metal tip protectors
- Mold flashings.
- Excessive wear.
- Debris lodged in the sole.
- Warped or improperly canted boot sole.
- Cut-outs in the sole that impede proper brake function. (If you are uncertain of boot compatibility, perform the **Clean vs. Lubricated Test**. Boots that fail this test or violate any of the above points should not be used with any Atomic or Salomon binding.)

The Binding Components

- Stripped, loose or missing screws.
- Condition of the AFD (ripped, loose, imbedded dirt, boot sole pattern, tread imprint, etc.).
- Condition of anti-friction inserts (where applicable).
- Missing or unreadable visual indicators and missing windows.
- Bent or broken baseplate, principal axis or housing.
- Stripped or jammed toe height and cup adjustment screws.
- Jammed release adjustment screw.
- Other visible wear.
- Improperly installed leash or brake.
- Irregular heel track function.
- Bent or broken baseplate, track or heel.

The Ski

- Mounting screws protruding through the base.
- Delaminated sidewall. This can be detected visually or by running your fingers along the sides of the ski.
- Binding baseplates not flush with ski surface.
- Delaminated topskin.
- Pre-drilled holes. As a general rule, bindings should not be installed on skis that have previously been drilled for three or more sets of bindings.

The Ski Brake

- Improper brake arm length.
- Improper installation.
- Broken entry pedals.
- Bent or broken brake arms.
- Strength of ski brake. A brake must not compress totally when the ski is set on a flat surface.
- Other visible wear.

Visual Inspection of the Complete System

Place the boot in the binding and check the accuracy of:

- Toe height adjustment (if applicable).
- Toe cup width adjustment (if applicable).
- Central roller adjustment (if applicable).
- Forward pressure adjustment.
- Visual indicator settings.
- Symmetrical mounting of bindings to ski center line (± 1 mm). This should be in the same location on both skis.

Test for Elastic Travel & Return



Lateral

Secure the ski. Hit the forefoot area of the boot with an object that will not damage the boot, such as a rubber hammer. **Fig. 1** Use sufficient force to move the boot off-center, but not hard enough to release the system. The boot should move off-center at least 5 mm and return to center within 2 mm of its original position.

Vertical

Depress the heel lever while pulling forward on the upper cuff of the boot until the boot heel lifts at least 5 mm. **Fig. 2** Release both hands simultaneously. The boot should return to the ski quickly and smoothly. This inspection can be performed either manually or by using a mechanical testing device. If a testing device is used, follow the recommendations of the test device manufacturer for proper procedure.

If the system passes these tests, mark "Pass" (✓) on the Workshop Form for "Test for Elastic Travel & Return". If the system fails, see

Troubleshooting.



Test for Boot/Binding Compatibility

Check the boot/binding combination to ensure all components are compatible. Unless a binding is specifically designed for use with both junior and adult norm boot soles, adult and junior systems cannot be combined, e.g., junior boots with adult bindings or vice versa. If the system passes this test, mark "Pass" (✓) on the Workshop Form for "Test of Boot-Binding Compatibility."

If you are not sure that the boot complies with standards or if you are not sure that the system components are compatible, see **Troubleshooting**.

REFERENCE

Page #	Section Name
45	Standard Boot Sole Dimensions
29	Troubleshooting
31	Workshop Form

MECHANICAL INSPECTION

It is a requirement* for Amer Sports indemnification that all ski/binding/boot systems be verified using a force or torque measuring device.**

A previously damaged binding component or boot may break during the added stress of mechanical testing. Consumers should be advised of this possibility prior to any mechanical testing of their equipment.

Release Value Within Specified Range

Twist Test (Toe)

Exercise the toe by releasing it one or more times in each direction. Measure and record the test result for both clockwise and counterclockwise directions with a force or torque-measuring device. The test result is the middle quantitative value of three measured release values. If the first two measured values are the same, there is no need to take a third measurement. **See Examples of Middle Quantitative Values (below)**

The toe passes this inspection if the test results in both directions fall within the "Inspection Range" as determined from the **Atomic/Salomon Adjustment Chart. See Sample Systems Inspection Ranges (below).**

If your test results for clockwise and counterclockwise release appear to be at opposite extremes of the inspection range, you may have an installation error or an incompatible

boot. This is known as asymmetric release. Troubleshoot the system and re-test after the problem has been corrected.

Examples of Middle Quantitative Values

3 Maximum Release Values	Middle Quantitative Value (Test Result)
45, 40, 50	45
60, 50, 50	50
30, 40, 45	40
55, 65, 60	60

Sample Systems Inspection Ranges Based on Skier Code "L"

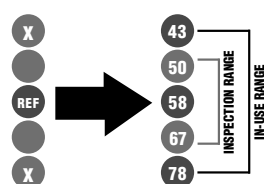

Forward Lean Test (Heel)

Exercise the heel by releasing it once. Measure and record the test result using a force or torque measuring device. The test result should be within the "Inspection

Range." If both twist and forward lean results fall within the appropriate inspection range, mark "Pass" (✓) on the **Workshop**

Form for "Release Value Within Specified Range."

Results Not Within the Specified Range

If the **Twist Test** or **Forward Lean Test** results are not within the "Inspection Range" but are within the greater "In-Use Range," the visual indicator of the component affecting the test result should be readjusted to bring the test result within the "Inspection Range." If the test result is outside the "In-Use Range," refer to **Troubleshooting**. It is not necessary to record any of the test

results on the **Workshop Form**. It is only necessary to record whether the system passed or failed each inspection and the final visual indicator settings. Any system component that repeatedly fails any inspection should not remain in use. When the technician is satisfied that all required procedures have been completed according to Atomic or Salomon's recommendations in this manual,

he or she must sign the **Workshop Form**. (The signing technician must be currently certified by Amer Sports.)

REFERENCE

Page #	Section Name
26	2013/2014 Adjustment Chart
29	Troubleshooting
31	Workshop Form

NOTE

***U.S.** Dealers only; recommended for Canadian Dealers.

****For** Amer Sports indemnification to apply, the shop must follow the test device manufacturer's requirements for:

- Proper use.
- Valid calibration.
- Calibration check at recommended intervals.
- Consistent results between technicians operating this device.

MECHANICAL INSPECTION (continued)

Boot/Binding systems wear with time. This is expected. Normal wear and/or fatigue of a system can be expected. If a system inspection indicates a system is not functioning as intended, the cause of the problem must be identified and corrective action should be taken.

Troubleshooting

The first step is to re-examine each component of the ski/binding/boot system individually. If a problem is found, e.g., stripped toe height screw, out-of-standard boot sole, improperly mounted binding, missing AFD, etc., proper **Binding-to-Boot Adjustments** cannot be made. No further work can be performed on the system. Mark "Fail" (✓) on this section of the **Workshop Form**.*

On used bindings, inspect all boot to binding points of contact for excessive wear.

If the system failed the **Test for Elastic Travel & Return**, check that all boot/binding interfaces are clean, smooth and clear of debris. If the boot is dirty, clean it with a solution of mild dish washing soap and water. If the binding is dirty, clean it according to the procedures described in **Maintenance and Repair**. Check that the boot enters the binding correctly. Make

* **The customer should be informed of, and authorize, action needed to correct the problem. Please refer to the Technical Reference section for warranty information on binding components covered under warranty.**

sure the boot is properly positioned in the toe and heel cups. Check the visual indicator settings. They should not exceed the minimum or maximum setting and should be set appropriately for the skier. Re-test the system for **Elastic Travel & Return**. If the system fails this test, mark "Fail" (✓) on this section of the **Workshop Form**.*

If the system failed the Test For Boot/Binding Compatibility, mark "Fail" (✓) on this section of the **Workshop Form**.* If you are not sure that the boot complies with the mandatory standards, or if you are not sure that the boot/binding system components are compatible, do a **Clean vs. Lubricated Test**. To perform a **Clean vs. Lubricated Test**, all adjustments to the system, e.g., visual indicator settings, forward pressure adjustments, etc., must be the same as when the system was previously tested. Lubricate the boot with a

mild dish washing soap wherever it contacts the binding and wipe off any excess lubricant. Perform the **Twist Test** and **Forward Lean Test** as done previously and record your results. Next, compare the results of the lubricated test with those of the previously performed non-lubricated clean test. Plot the results on the **Compatibility Tables**. If the results don't fall within the shaded "Pass" window on the table, the BOOT is incompatible with the binding and should not be used. Mark "Fail" (✓) on the **Workshop Form**.*

If no problems have been found with the system and the **Release Value Within Specified Range** cannot be obtained, further tests must be undertaken. First, switch testers to check operator accuracy. Next, check the accuracy of the testing device per the device manufacturer's recommendations. Re-test the system. If the system releases

outside the "In-Use Range," mark "Fail" (✓) on this section of the **Workshop Form**.*

If the customer refuses to have work done that is necessary to bring the system within standards, or requests work that violates the recommendations of this manual, the technician should check the box next to the statement indicating out-of-standard components on the **Workshop Form**. A note should be made in the Comment section of the form describing the problem and the skier should be warned that continued use of the system is inadvisable. The shop will not be indemnified for work done on that system.

REFERENCE	
Page #	Section Name
27	Test For Elastic Travel and Return
27	Test For Boot/Binding Compatibility
31	Workshop Form
64	Retail Binding Limited Warranty

Compatibility Tables: Clean vs. Lubricated Tests

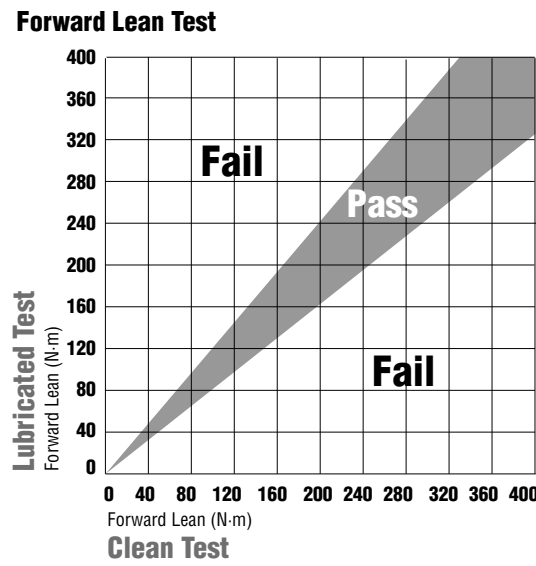
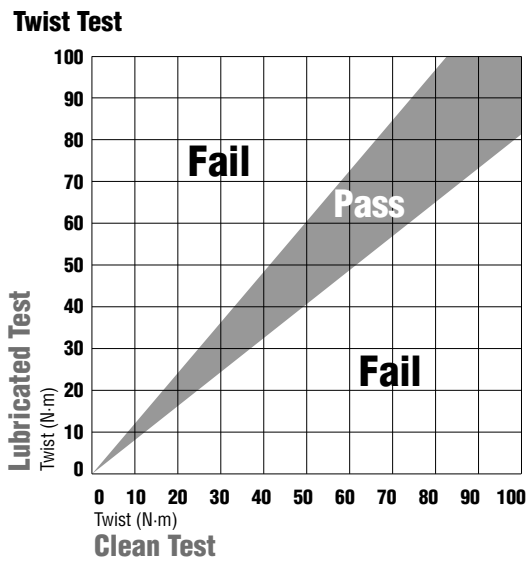

RETAIL-SPECIFIC INSTRUCTIONS

Retail Skier Instruction & Warning

When the Certified Technician signs or initials the Workshop Form, the technician attests that all procedures have been completed. It is not necessary for the technician to personally provide the skier with instructions as long as the shop does. To help reduce your shop's liability risk and to receive indemnification from Amer Sports, take the following steps whenever a skier picks up their equipment. (If the individual picking up the equipment is not the intended user, treat that individual as though they were the intended user. In the case of minor skiers, follow these steps in the presence of both the minor skier and a parent or legal guardian.)

Explanation of Entry/Exit/Re-entry
The proper use of the system (entry, exit and re-entry) must be explained using the skier's own system as an example.

Explanation of Parts and Release Adjustments

Show the skier where the visual indicator adjustment caps/screws are located. Point out the binding-to-boot adjustments. Indicate where the visual indicator settings are recorded

on the Workshop Form and have the customer verify that the settings recorded on the form agree with the settings appearing in the visual indicator window of the binding. (It is not necessary to explain how these numbers are derived.) Although skiers may work on their own system, suggest that if a problem develops, the system should be taken to an Authorized Binding Dealer.

Receipt of In-Box Instructions

When a skier purchases a new binding, it is required that they also receive the in-box pamphlet included in each binding box. The pamphlet should be reviewed with the skier so that it is fully understood.

Skier Signature on the Workshop Form

The skier must read and understand the conditions specified in the Liability Release Agreement. Point out that the skier is signing a release of liability and that included in the release is a specific warning that the binding will not release under all circumstances nor is it possible to predict every situation in which it will release, and it is, therefore, no guarantee of the skier's safety.

The Skier must then sign the Workshop Form, indicating the skier:

- Has been instructed in the proper use of the equipment.
- Has received the in-box pamphlet (new bindings only).
- Has verified that the visual indicator settings correspond to the recorded settings on the Workshop Form.
- Has read and understands the specific information on the Workshop Form that releases the shop, manufacturer and distributor from liability.
- Understands that skiing involves inherent risks and that injuries are a common and ordinary occurrence of the sport.
- Understands that included in the Liability Release Agreement is the specific warning that the binding will not release at all times or under all circumstances where release may prevent injury or death, nor is it possible to predict every situation in which it will release, and it is, therefore, no guarantee of their safety.
- Understands that the bindings should be maintained as per suggestions in **Maintenance**

Guidelines prior to the beginning of each season and every 30 skier days per year.

The person who signs the Workshop Form should be the intended user of the equipment. In the case of a minor skier, the signature on the form must be that of the skier's parent or legal guardian. If someone other than the skier or the skier's parent or guardian picks up the equipment, this person should be treated as though he or she were the skier and, therefore, must sign the Workshop Form. A note must be placed on the Workshop Form that the "agent" must transmit the information to the intended user. If a skier refuses to sign the Workshop Form, Amer Sports will not provide indemnification and the shop should consider refusing to provide service to the skier.

Receipt of Workshop Form

The skier must be given a copy of the Workshop Form that includes a signed copy of the Liability Release Agreement.

Retail Record Keeping

An Authorized Dealer is required to keep accurate records of work performed. Aside from the legal reasons, accurate records provide a permanent history of the customers you have serviced over the years. Workshop records must be kept for five years or for the statute of limitations of the state or province, whichever period is longer.

The following is a list of information* that must be recorded every time an Atomic or Salomon binding is mounted and/or adjusted. It is not necessary to use an **Atomic/Salomon Workshop Form**, but any form that the shop uses should include all the information listed below.*

1. *Date of transaction.
2. *Name and address of the skier.
3. *Skier's height, weight, age and skier type.
4. *Skis (brand, model and serial number).
5. *Boot (brand, model and sole length).

6. *Binding (brand and model).
7. *Skier's Code.
8. *System inspection results ("Pass" or "Fail" for all functional tests must be indicated).
9. *Visual indicator settings.
10. *Certified Technician's initials or signature attesting that all functional tests and instructional procedures have been completed.
11. *Liability Release Agreement which is either the same as/ or substantial equivalent of the Atomic/Salomon form.
12. *Skier signature (or that of the skier's agent or, in the case of a minor, that of the skier's parent or guardian) attesting that the skier:
 - a. Has been instructed in the proper use of the equipment.
 - b. Has received the in-box pamphlet (new bindings only).
 - c. Has verified that the visual indicator settings correspond to the recorded visual indicator settings.
 - d. Has read and understands the Liability Release Agreement on the Workshop Form.
 - e. Understands that there are inherent and other risks in the sport of snow skiing and agrees to assume those risks.
 - f. Understands that included in the Liability Release Agreement is the specific warning that the binding will not release under all circumstances where release may prevent injury or death, nor is it possible to predict every situation in which it will release, and it is, therefore, no guarantee of their safety.
 - g. Understands that bindings should be maintained as per suggestions in Maintenance Guidelines.
13. Notes on the boot sole's material, shape and/or condition should be made when necessary.
14. If the visual indicator settings vary from the recommended



setting, note the reason for this. Attach a signed release to the Workshop Form. NOTE: Current Atomic/Salomon workshop and rental forms include a "Requested Settings" option for customer requested settings, which eliminates the need for a separate release in such instances.

15. Refusal to serve statement. This statement should be written so as to absolve the ski shop from any liability when the customer refuses to have work performed as per guidelines of Atomic or Salomon and the shop

NOTE	
* Without this information, indemnification will not apply.	
REFERENCE	
Page #	Section Name
31	Atomic/Salomon Workshop Form
31	Liability Release Agreement
38	Maintenance Guidelines

RETAIL-SPECIFIC INSTRUCTIONS (continued)

Atomic/Salomon Workshop Form*

Taken By: _____ **Due Date:** _____ **Date:** _____

Name: Last: _____ First: _____ M.I.: _____

Street: _____

City: _____

State: _____ Zip: _____

Phone #: _____

Your Weight: _____ lbs. Your Height: _____ in. Your Age: _____

Downhill Skiing Snowboard

Indicate Skier Type: _____ Stance: Regular Goofy

L _____ R _____

Acknowledgement of Personal Information, Equipment Instructions & Liability Release Agreement

I have accurately represented the above listed information and it is true and correct. I will not use any of my equipment until I have received instruction on its use and I fully understand its use and function (including receipt of accompanying manufacturer's instruction pamphlet(s) for new equipment). I agree to verify that the visual indicator settings to be recorded on this form for downhill ski equipment, and skiboards equipped with release bindings, agree with the number appearing in the visual indicator windows of the equipment to be listed on this form. I agree to read and execute the LIABILITY RELEASE AGREEMENT on the back of this form.

Equipment User's Signature: _____

Parent/Guardian Signature (if not adult user): _____

Equipment:

Name:	Model:	\$:
Serial No:		
BOOTS		
Model:	Sole Length (cm):	
BINDINGS		
Brand:	Model:	
POLES:		
Brand:	Length:	
Other:		
Work Requested	EQUIPMENT TOTAL	\$

FWD PRESSURE **Equipment**

VISUAL INDICATOR SETTING **Labor**

TOE HEIGHT **Sub-Total**

SCREW TENSION **Tax**

WAXED/EDGED **TOTAL**

TECH INITIAL: _____

RELEASE BINDING SYSTEM INSPECTION Skier's Code



Binding-to-Boot Adjustment	PASS	FAIL	N/A
Test for Elastic Travel & Return	{ }	{ }	{ }
Test of Boon-Binding Compatibility	{ }	{ }	{ }

Release Value Within Specified Range
 Due to system components that are out of standard or otherwise unsuitable, the work cannot be performed. (See COMMENTS below)

Visual Indicator Settings		Requested Settings	
L. Toe	R. Toe	L. Toe	R. Toe
L. Heel	R. Heel	L. Heel	R. Heel

Comments: _____

Technician's Signature: _____

Name: _____ VER 9.13

LIABILITY RELEASE AGREEMENT

I understand that the binding system cannot guarantee the user's safety. In downhill skiing, and skiboarding with skiboards equipped with release bindings, this binding system will not release at all times or under all circumstances where release may prevent injury or death, nor is it possible to predict every situation in which it will release. In snowboarding, cross-country skiing, skiboarding with skiboards equipped with non-release bindings, snowshoeing and other sports utilizing equipment with non-release bindings, the binding system will not ordinarily release during use; these bindings are not designed to release as a result of forces generated during ordinary operation.

I understand that the sports of skiing, snowboarding, skiboarding, snowshoeing and other sports (collectively "RECREATIONAL SNOW SPORTS") involve inherent and other risks of **INJURY** and **DEATH**. I voluntarily agree to expressly assume all risks of injury or death that may result in any way to the use of this equipment.

I understand that a helmet designed for RECREATIONAL SNOW SPORTS use will help reduce the risk of some types of injuries to the user at slower speeds. I recognize that serious injury or death can result from both low and high energy impacts, even when a helmet is worn.

I AGREE TO RELEASE AND HOLD HARMLESS the facility servicing this equipment, its employees, owners, affiliates, agents, officers, directors, and the equipment manufacturers and distributors and their successors in interest (collectively "PROVIDERS"), from all liability for injury, death, property loss and damage which results from the equipment user's participation in the RECREATIONAL SNOW SPORTS for which the equipment is provided. Or which is related in any way to the use of this equipment, including all liability which results from the NEGLIGENCE of PROVIDERS, or any other person or cause.

I further agree to defend and indemnify PROVIDERS for any loss or damage, including any that results from claims or lawsuits for personal injury, death, and property loss and damage related in any way to the use of this equipment.

This agreement is governed by the applicable law of this state or province. If any provision of this agreement is determined to be unenforceable, all other provisions shall be given full force and effect.

I, THE UNDERSIGNED, HAVE READ AND UNDERSTAND THIS LIABILITY RELEASE AGREEMENT.

User's Signature: _____

Date: _____

Parent/Guardian/Agent: I verify that I am the parent, guardian or agent of the equipment user; I have the authority to enter into this agreement on behalf of the equipment user; and I agree to be bound by the terms and conditions of this agreement.

Parent/Guardian/
Agent's Signature: _____

Date: _____

NOTE

*U.S. form shown.

To order forms in the U.S., log on to <http://us380.alphagraphics.com>

In the center of the right-hand column enter username: **shopforms** and password: **shopforms** - click on "Submit"

On the welcome page, click on **Business Forms**. Choose your form and quantity. If you are purchasing the form that will be imprinted with your information, follow the prompts to input the information you would like printed on the forms.

Follow the prompts to create your account. Write down your username and password - you will need them the next time you want to log in! Click "Save" to continue. Follow the prompts to check out, you will be billed by Amer Sports. Your order will ship in 5-7 business days. Have questions? Call 801.479.8339 or email nataliek@alphagraphics.com

REFERENCE

Page #	Section Name
30	Skier Instruction & Warning

RENTAL-SPECIFIC INSTRUCTIONS

The mechanical inspections discussed in this section are required of U.S. dealers and are **strongly recommended** for Canadian dealers, both in the interest of consumer protection and as a sound risk-management strategy. Maintenance records must be kept for all bindings and boots in inventory for both pre-season and in-season inspections. Only Pass/Fail results should be recorded. If bindings are switched from one pair of skis to another, this should be noted on the records. To receive indemnification from Amer Sports, maintenance records must be kept on file for five years or the statute of limitations in your state or province, whichever is longer. All rental skis must have an Identification Number and a method to record maintenance and testing information (sample **Ski/Binding Maintenance Record** and **Boot Maintenance Record** are available as PDF documents from the certification website).



Rental Inspection Summary

Since it is impractical to perform a full inspection each time a system is rented, a routine of preseason and inseason inspections has been

developed to verify release indicator accuracy, confirm correct equipment function, and assure proper assembly and adjustment

procedures by the rental shop staff. Fully implemented, the procedures that follow provide rental shop customers a standard of care

equivalent to that provided retail shop customers under current ISO [and ASTM] standards.

Pre-Season Inspection

Preseason inspections are performed on components of the release system: bindings and boots. All rental bindings, new and used, are visually inspected, and then tested using specially selected Reference Boots. Bindings that fail go through a troubleshooting procedure

to identify and correct the deviation or malfunction. If this procedure does not correct the problem, the binding is removed from inventory. All rental boots, new and used, are visually inspected for damage, wear, contamination, broken or missing parts, or inferior materials

at contact points with the binding. In addition, one boot per "cell" is tested for boots that are new to the rental inventory. A cell is all boots of the same make, model, age, and shell size. A random selection of 5% of all boots, previously accepted into inventory, is also tested. Tests

are performed with a test device and a pair of specially selected reference bindings. If a boot fails, all boots from that cell are then tested. Boots that fail and cannot be repaired are removed from inventory.

Inseason Inspection

Inseason inspections are performed on complete rental systems to ensure that the equipment is adjusted appropriately and continues to function correctly. Typically 5% of the rental inventory is tested during each two weeks sampling period. The random sample is equally divided between equipment

that is available for rental and equipment that has just been rented. The equipment in the "as rented" category is from real skiers in the condition in which it is either dispatched or returned, while the "available for rental" equipment may be set up for fictitious skiers. Only single skis, not pairs, are

tested, and testing at the toe is only required in one direction. A count is maintained of test results that exceed allowable limits. The magnitude and frequency of these deviations determines the frequency of future inspections. Shops that fail an inspection must sample daily until the source of

the problem is found and corrected. Then, as inspection results improve, the frequency of sampling and inspection is relaxed.

Important Terms

Correction Factor: The value that must be added or subtracted from the initial visual indicator setting to bring the test result within the Inspection Tolerance (or Inspection Range).

Directions of Release: Unless otherwise specified (see Inseason Inspection), the directions of release to be tested are forward lean and clockwise and counter clockwise in twist.

Test Device: A device that meets ISO standard 11110 [or ASTM standard F1061] and has been checked and maintained in the manner specified by the device manufacturer.

Test Result or Release Torque: The middle quantitative value of three tests made in the same direction.

RENTAL-SPECIFIC INSTRUCTIONS (continued)

Inspection Procedures

Preseason Inspection

Reference Boot Selection

The Reference Boot is a boot of a designated sole length that is otherwise typical of the boot inventory. Use the procedure below if the boot inventory includes several models and a representative boot cannot be easily identified.

1. Select five single boots with sole lengths as specified in **Table A** for the binding type to be tested: adult, junior, or child.
2. Clean all five boots with a mild detergent and water.
3. Adjust a rental binding to the release indicator setting specified in **Table A** for the binding type.
4. Fit the binding to the boots and determine the Release Torque in all three directions of release (forward lean and both directions in twist).
5. Average the Release Torque for CW and CCW twist release.
6. Reject and replace any boot with a CW to CCW difference of more than 6 N-m for adult boots or 4 N-m when testing child boot types.
7. Rank the five twist results and select as the Reference Boot for twist, the middle boot.
8. Rank the five forward lean results and select as the Reference Boot for forward lean, the middle boot.

Preseason Binding Inspection

The procedure that follows is an integral part of preseason maintenance. It is also a good way to determine if maintenance is adequate and which units have outlived their usefulness and must be removed from inventory.

1. Clean areas of the bindings that contact the boot and perform all preseason binding maintenance.

2. Visually or manually check:
 - AFD condition.
 - Brakes function.
 - Release indicator readability and travel.
 - Screw tightness.
 - [other product specific inspections if required]
3. Fit each binding to the Reference Boot and adjust the release indicators to the value in **Table A**.
4. Check that the heel track and toe track code (if any) agree with the sole length code (if any) of the Reference Boot.
5. With the Reference Boot in the binding, verify elastic travel of the toe piece by striking the boot toe with a mallet or dead hammer and checking that the toe piece returns the boot quickly and completely to center.
6. Verify elastic travel of the heel piece by lifting the boot while depressing the heel piece cocking lever and checking that the heel piece returns the boot quickly and completely to the latched position. [other product specific procedures if required]
7. Manually release the binding 3 times in each direction.
8. Lubricate all boot/binding interfaces with a mild liquid detergent and water solution.
9. With the Ski Binding Test Device determine the Release Torque for each direction of release (forward lean and both directions in twist).
10. Record "PASS" in the binding's maintenance record if Test Results are within the Inspection Ranges provided in **Table A**.
11. Set the ski aside if the Test Result in any directions of release is outside the Inspection Range in **Table A**.
12. Follow Troubleshooting Procedure from the binding manufacturer's tech manual for units that have been set aside and retest if changes in the unit's condition or adjustment are made.
13. Record "FAIL" in the binding's maintenance record if, after troubleshooting, test results in any direction of release are outside the In-Use Range. Replace the "failed" unit and retest before returning the ski to service.
14. If after troubleshooting, Test Results are outside the Inspection Range but within the In-Use Range, apply a Correction Factor to the unit and note the Correction Factor for that unit in the binding's maintenance record.
15. If many bindings fail, check the test device and re-inspect the Reference Boot. If necessary, select another boot and retest the bindings.

Preseason Boot Preparation

The procedure that follows is an integral part of preseason maintenance.

1. Clean all boots with [a mild detergent and water], and repair or replace damaged or missing parts.
2. Visually check:
 - Conformance with ISO and other applicable standards. If the boot contacts the binding, brake, or AFD in areas other than the designated contact points, it may be incompatible with the binding. [product specific figure or description]

- Boot material. If the sole at the contact points with the binding or AFD can be scratched with a finger nail, the boot may be of inferior quality and incompatible with the binding.
 - Boot sole condition. If the boot sole is damaged, worn, or contaminated at contact points with the binding or AFD in a manner which can not be corrected, the boot may be incompatible with the binding.
 - Brake compatibility with sole.
 - Rubber and/or metal sole protectors. If such materials contact the binding or AFD the boot may be incompatible with the binding.
 - Mold flashings. Flashing which can be seen or felt at contact points with the binding, brake, or AFD must be carefully removed.
3. Remove from inventory all boots that have failed the visual check.

Preseason Boot Sampling

Although sampling eliminates the need to test every boot before the season starts, the sample chosen must be representative of the inventory.

1. For boots that are new to inventory or have never been inspected, take a single boot from each cell (a cell is all boots of the same make, model, year, and shell size).
2. For used boots, take a 5% (but not less than 16 or more than 80) random sample of the entire inventory. Make sure that there is at least one boot from each cell in the sample.

REFERENCE

Page #	Section Name
27	Final Checking
27	Test for Elastic Travel & Return Release Value Within Specified Range
29	Troubleshooting
45	Standard Boot Sole Dimensions

Table A : Preseason Binding Inspection*

Skier Code	Binding Type	Sole Length (mm)	Release Indicator Setting	Reference Torque (N-m)		Inspection Range (N-m)		In-Use Range (N-m)	
				Twist	Forward Lean	Twist	Forward Lean	Twist	Forward Lean
F	Children	258	2.0	20	75	17-23	64-87	14-27	52-102
J	Junior	306	4.5	43	141	37-50	141-194	31-58	120-229
L	Adult	327	6.0	58	229	50-67	194-271	43-78	165-320

* This is an example only. Check the manufacturer's tech manual before proceeding

RENTAL-SPECIFIC INSTRUCTIONS (continued)

Inspection Procedures (continued)

Preseason Boot Inspection

The procedure that follows helps to assure both boot/binding compatibility and boot interchange ability. Note: when using **Table A**, in the Boot Inspection procedures that follow, the Sole Length and Release Indicator Setting columns should be ignored.

1. Randomly select a pair of bindings that have passed the preseason inspection from each binding type; adult, junior, child.
2. Lubricate all boot/binding contact points with a mild liquid detergent.
3. Without regard to whether the boot is new or used, sort the sample by sole type and length

according to the 20mm Sole Length Categories defined by the binding manufacturer's Release Value Selection.

4. In each Sole Length Category rank the boots by sole length and select the middle boot.
5. In each Sole Length Category fit the appropriate reference bindings to this "typical" boot and adjust the two bindings to release as close as practical to the Reference Torque in **Table A**. Use the Reference Torque corresponding to Skier Code [L] for the Adult binding, [J] for the Junior binding, and [J] for the Child binding.

6. Rinse the lubricant from one binding and mark it "clean." Mark the other "lubricated."
7. Test each boot in the Sole Length Category with the clean Reference Binding and then the lubricated Reference Binding in both twist and forward lean (only one direction in twist is required for the clean binding).
8. Set aside any boots for which the lubricated Test Result is more than 20% less than the clean Test Result in the same direction of release or the lubricated Test Result, in any direction of release, is outside of the Inspection Range provided in **Table A** for the Skier Code used

to set up the Reference Binding (L, J, or F).

9. Repeat the Visual Check on all boots that have been set aside, correct any defects noted, and retest. Remove from inventory boots that fail the retest.
10. Check all other boots from the same cell (make, model, year, and shell size) as those that failed.

NOTE: On completion of the preseason inspection, clean the liquid detergent from the equipment (and lubricate the binding before returning it to service).

Inseason Sampling And Inspection

The Inseason Inspection is a test of complete systems and all the procedures used by the rental staff to assemble and adjust the system. The program uses random samples of rental inventory taken at routine intervals. Any sampling program that gives every unit of inventory the same chance as every other of being picked is valid.

Sample Frequency

Random sampling is conducted throughout the entire season. Frequency is as follows:

1. After 7 days of operation.
2. If the sample passes, the next sampling is taken after another 7 days of operation.
3. If two consecutive samples pass, sampling frequency is increased to 14 days.
4. If a sample fails at any time, daily sampling is instituted until two consecutive samples pass, at which point weekly sampling resumes.

Sample Size

Sample size is 5% of inventory but not less than 16 nor more than 80 units as noted in **Table B**. Sample size is based on average daily output. If rental output drops below 50% of capacity over the sampling period, the sample size can be reduced proportionately.

Inseason Inspection

1. Take a random sample of the rental inventory as determined by **Table B**. Take half the sample from inventory as it is either rented or returned and the remainder from inventory available for rental.
2. Wipe the boot clean and cycle the boot/binding systems at least once in each direction.
3. Test sample units in Twist (one direction only) and Forward Lean.
4. Compare the Test Results with the Inspection Range for the appropriate Skier Code.
5. If the results are within the Inspection Range, the unit passes.

6. If the results are outside Inspection Range but within the In-Use Range, count the unit as a Class I Deviation.
7. If the results are outside the In-Use Range, count the unit as a Class II Deviation.
8. Check elastic travel and visually inspect the ski brake function, interface areas between boot and binding, including AFD, lug height adjustment (if appropriate), and forward pressure. Count any deficiencies as Class I Deviations.
9. If more than the maximum number of Class I Deviations given in **Table B** are found in the sample, or a single Class II Deviation is detected the sample fails and daily sampling must be conducted until the problem that led to the failed sample is found and corrected. See the "Troubleshooting" chapter of the binding manufacturer's technical manual following a failed Inseason Inspection.

10. Record the date the sample was tested, the number of units tested, the number of Class I and Class II (or III) Deviations, whether the sample passed or failed and any actions taken. There is no need to record the identity of units tested or actual Test Results.

Table B : Sample Size

Inventory Size (Pairs)	Sample Size (Units)	Maximum Class I Deviations
100	16	3
200	20	4
300	30	6
400	40	8
500	50	10
600	60	12
700	70	14
800	80	16
900	80	16

Demo Inspections > Incomplete Systems

Skis

Bindings intended for demo applications, where customers supply their own boots, must be inspected using the procedures described for rental equipment. Whenever a demo or rental binding is used with a customer's own boot, inspect the

customer's boot for **Boot/Binding Compatibility** as described on **page 27**. Reject any boots that fail visual inspection. Both boots of the pair must be inspected and the boot sole lengths of both boots verified.

Boots

Whenever customers rent boots for use with their own skis, the customer's binding system must be mechanically inspected (using the rental boot) according to procedures described for retail equipment.

REFERENCE

Page #	Section Name
27	Final Checking
27	Test for Elastic Travel & Return
28	Release Value Within Specified Range
29	Troubleshooting

RENTAL-SPECIFIC INSTRUCTIONS (continued)

Rental Skier Instruction & Warning

It is the Authorized Dealer's responsibility to adequately assist each rental customer in equipment selection and to properly fit rental boots. Instructions regarding proper use of equipment must also be given at the time rental equipment is provided.

When the Certified Technician signs or initials the Rental Form, the technician is attesting that all functional and instructional procedures have been completed. To reduce your shop's liability risk and to receive indemnification from Atomic or Salomon, you must take the following steps when the skier receives their equipment. (The individual picking up the equipment must be the intended user, or in the case of a minor, the user's parent or guardian.)

1. Show how to step into the binding.
2. Show how to step out of the binding.
3. Point out the visual indicator settings on the binding's toe and heel pieces. The skier must verify that these settings agree with the settings recorded on the Rental Form.
4. Ask the skier to read the Liability Release Agreement. Point out that the skier is signing a release that limits liability. Included in this Liability Release Agreement is the specific warning that bindings will not release under all circumstances where release may prevent injury or death, nor is it possible to predict every situation in which they will release, and are, therefore, no guarantee of safety.
5. The skier must understand that there are inherent and other risks in the sport of skiing.

6. The skier* must then sign and date the Rental Form.
7. The skier must be given a copy of the rental form that includes a signed copy of the Liability Release Agreement.

Rental Record Keeping

Proper rental record keeping is key to your shop's risk management program. Without a properly filled out form, including a signed Liability Release Agreement, indemnification from Amer Sports will not apply.

A Rental Form (single or multi-use) must be filled out for each rental transaction. The multi-use form may be used for multiple transactions with the same skier, provided that each transaction is documented, dated, and signed. A Liability Release Agreement the same as or the equivalent to the Atomic/Salomon Liability Release Agreement must be included on the Rental Form. The skier must read, understand, sign and date this release. A copy of the properly filled out Rental Form must be kept on file for five years or the statute of limitations of the state or province, whichever is longer. Multiple skier forms that allow each skier to read and sign the same form may be used if the form meets the requirements outlined in this section. It is recommended that the form be reviewed by Amer Sports' Legal department prior to use. The person who signs the rental form must be the skier who is going to use the rental equipment. In the case of a minor skier, the signature on the form must be that of the skier's parent or legal guardian.

The following is a list of information that should be recorded for every rental transaction. It is not necessary to use an Atomic/Salomon Rental Form, but any form that the shop uses must include the information* listed below. Without this information*, indemnification will not apply.

1. *Rental dates.
2. *Name and home address of the skier.
3. Skier's home phone number.
4. Skier's identification.
5. *Skier's height, weight, age, and skier type.
6. *Boots' inventory number. (If the skier is using their own boots, the boot brand, model and sole length must be indicated on the Rental Form and the boot must pass visual examination.)
7. *Skis' inventory number. (If the skier is using their own skis, the system would fall under Retail guidelines and a complete system inspection, including a mechanical inspection, must be performed and documented on a Workshop Form.)
8. *Visual Indicator Settings.
9. *Amer Sports Certified Technician's signature or initials attesting that all required procedures have been completed.
10. Rental fee.
11. *Liability Release Agreement that is either the same as, or the substantial equivalent of, the Atomic/Salomon release. Consult your shop's legal advisor to be sure the language and type size of this agreement conforms to state or provincial law. If a form other than the Atomic/Salomon form is used, the language shall accomplish the same purpose and have the same legal effect as the language contained in the Atomic/Salomon agreement.
12. *Skier's signature (in the case of a minor skier, the signature on the form must be that of the skier's parent or legal guardian) and date attesting that the skier:
 - a. Has been instructed in the proper use of the equipment.

- b. Has verified that the visual indicator settings correspond to the recorded visual indicator settings.
- c. Has read and understands the Rental and Liability Release Agreement on the rental form, releasing the shop from liability.

NOTE

* On the 2013/2014 Atomic/Salomon Rental Form, the skier (or in the case of a minor, the skier's parent or legal guardian) must sign and date the Liability Release Agreement.

REFERENCE

Page #	Section Name
27	Final Checking & System Inspection
36	Atomic/Salomon Rental Form
36	Equipment Rental & Liability Release Agreement
37	Post Accident Ski Equipment Inspection Report

POST ACCIDENT RECORD KEEPING

Post Accident Ski Equipment Inspection Report Form

A Post Accident Ski Equipment Inspection Report Form the same as or equivalent to the form provided must be filled out if a person returns the equipment, whether the equipment is theirs or belongs to someone else, and claims that they or someone else were injured. The report must be completed with "as is" mechanical inspection measured release values. An insufficient or improperly completed form may cause denial of indemnification.

Inspection Report Instructions

General Information

- All information should be printed clearly.
- Any mistakes should be corrected and initialed.
- If information is unknown, mark UNK in the appropriate area.
- If information does not apply, mark N/A in the appropriate area.

Skier Information Section

- Skier information should be taken from the rental or workshop form.
- Accident/injury information should be taken from the ski patrol accident report (if available).

Equipment Information Section

- Information should be taken from the visual inspection of equipment.

Equipment Inspection/Tests Section

- Refer to the most current Shop Practices Manual for Standard Boot Sole information.
- Equipment inspections should be conducted on the equipment "as is".
- Inspection of binding adjustments should be in accordance with recommendations set forth in the most current Shop Practices Manual.
- System visual inspections should be in accordance with recommendations set forth in the most current Shop Practices Manual.
- Mechanical inspection tests should be conducted at room temperature.
- The mechanical testing device should be properly calibrated and operated in the manner recommended by the device manufacturer.
- Mechanical tests should be conducted on the equipment "as is".
- Test results should be recorded in Newton meters.

Facility/Personnel/Testing Device Section

- The "Inspection Technician" should be a current Amer Sports Certified Technician.
- The report should be reviewed by the shop manager.

Post Accident Ski Equipment Inspection Report

Workshop/Rental Form No.

Skier Information

NAME				ACCIDENT DATE	
HEIGHT	WEIGHT	AGE	SEX (circle one) M F	SKIER TYPE (circle one) I II III -I III+	
INJURY					
RIGHT OR LEFT (circle one) R L		SKI AREA			

Equipment Information

SKI MAKE	MODEL	LENGTH
SERIAL No.	RENTAL I.D. No. (if applicable)	
BOOT MAKE	MODEL	SIZE
BOOT SOLE LENGTH in mm	RENTAL I.D. No. (if applicable)	
BINDING MAKE	MODEL	
TOE VISUAL INDICATOR (DIN) SCALE to	HEEL VISUAL INDICATOR (DIN) SCALE to	
RENTAL FORWARD PRESSURE (SYNCHRO) SETTING(S):		

Equipment Inspection/Tests

Right Ski/Binding/Boot

N/A	YES	NO	(check one)	
<input type="radio"/>	<input type="radio"/>	<input type="radio"/>		Boot sole within Industry Norm Standards
<input type="radio"/>	<input type="radio"/>	<input type="radio"/>		All boot parts present, working correctly
<input type="radio"/>	<input type="radio"/>	<input type="radio"/>		AFD OK and intact
<input type="radio"/>	<input type="radio"/>	<input type="radio"/>		Forward Pressure correct
<input type="radio"/>	<input type="radio"/>	<input type="radio"/>		Toe Height correct
<input type="radio"/>	<input type="radio"/>	<input type="radio"/>		Toe Wings set correctly
<input type="radio"/>	<input type="radio"/>	<input type="radio"/>		Brake fully functional
<input type="radio"/>	<input type="radio"/>	<input type="radio"/>		Ski damaged (bent etc.)
<input type="radio"/>	<input type="radio"/>	<input type="radio"/>		System passes visual inspections
<input type="radio"/>	<input type="radio"/>	<input type="radio"/>		Rental heel forward pressure setting correct

Left Ski/Binding/Boot

N/A	YES	NO	(check one)	
<input type="radio"/>	<input type="radio"/>	<input type="radio"/>		Boot sole within Industry Norm Standards
<input type="radio"/>	<input type="radio"/>	<input type="radio"/>		All boot parts present, working correctly
<input type="radio"/>	<input type="radio"/>	<input type="radio"/>		AFD OK and intact
<input type="radio"/>	<input type="radio"/>	<input type="radio"/>		Forward Pressure correct
<input type="radio"/>	<input type="radio"/>	<input type="radio"/>		Toe Height correct
<input type="radio"/>	<input type="radio"/>	<input type="radio"/>		Toe Wings set correctly
<input type="radio"/>	<input type="radio"/>	<input type="radio"/>		Brake fully functional
<input type="radio"/>	<input type="radio"/>	<input type="radio"/>		Ski damaged (bent etc.)
<input type="radio"/>	<input type="radio"/>	<input type="radio"/>		System passes visual inspections
<input type="radio"/>	<input type="radio"/>	<input type="radio"/>		Rental heel forward pressure setting correct

VISUAL INDICATOR SETTINGS

Toe:	Heel:	
CLOCKWISE TWIST MEASURED RELEASE VALUES*		
I	II	III
COUNTERCLOCKWISE TWIST MEASURED RELEASE VALUES*		
I	II	III
FORWARD LEAN MEASURED RELEASE VALUES*		
I	II	III

VISUAL INDICATOR SETTINGS

Toe:	Heel:	
CLOCKWISE TWIST MEASURED RELEASE VALUES*		
I	II	III
COUNTERCLOCKWISE TWIST MEASURED RELEASE VALUES*		
I	II	III
FORWARD LEAN MEASURED RELEASE VALUES*		
I	II	III

* Record the number of results recommended by the manufacturer of the testing device. If not certain, record 3 values for each test.

Facility/Personnel/Testing Device

SHOP NAME	INSPECTION TECHNICIAN	DATE
REPORT REVIEWED BY	DATE	TESTING DEVICE BRAND
		MODEL



Photo: Christian Pondella

BINDING MAINTENANCE & REPAIR

Any incorrect use of an Atomic or Salomon part or accessory or installation of a non-compatible brand accessory with an Atomic or Salomon system will automatically void both the warranty and indemnification for that system.

Retail & Rental Guidelines

Retail Guidelines

Atomic and Salomon bindings require a minimum of maintenance to enhance performance and their useful life. They should be cleaned, inspected and lubricated prior to each season and every 30 skier days per season as follows:

- Inspect all components for damage or excessive wear. Repair or replace damaged or excessively worn parts and/or components.
- Clean the exposed areas of the components with a cloth or rag. Wipe any dirt or grit from the binding housings, heel track and the region under the heel cup. Do

not use solvents or high pressure liquid cleaning systems to clean bindings.

- Apply grease to the lubrication points indicated for the appropriate model. Do not use silicone or penetrating oils unless the lubricant is specifically approved.

- Recommend to the skier that routine maintenance and inspections be performed by an Authorized Dealer. This will help ensure that any problem that may develop with the system can be detected and corrected by a trained technician.

Rental Guidelines

Proper maintenance of rental systems includes a complete inspection of the entire rental inventory prior to the ski season. Bindings should be cleaned, inspected and lubricated in the following manner:

- Inspect all components of each set for damage or excessive wear. Repair or replace damaged or excessively worn parts and/or components.
- Remove the heel by sliding the housing off the rear of the heeltrack*.
- Clean the exposed areas of the components with a cloth or rag. Wipe

any dirt or grit from the binding housings, heel track and the region under the heel cup. Do not use solvents or high pressure liquid cleaning systems to clean bindings.

- Apply grease to the lubrication points indicated for each model. Do not use silicone or penetrating oils unless the lubricant is specifically approved.
- Slide the heel back on the track.
- This should be followed by periodic in-season inspections and when a binding looks particularly dirty or if visual inspection reveals that some-

thing may be wrong. This helps to ensure that all components are functioning correctly.

Never attempt to interchange any SR, SC or retail toe baseplates or heel tracks with other model baseplates or heel tracks.

Rental Post Season Storage

To prepare rental equipment for summer storage:

- All binding visual indicator adjustments should be reduced to the lowest setting. Do not attempt to adjust

the release setting below the lowest setting as damage may result.

- The binding heels should be stored in the closed position.
- The equipment should be stored in a cool, dry and ventilated area away from direct sunlight.

NOTE

- * To remove heel pieces on tracks with heel locks, loosen the rear mounting screws at least three turns. Pull the heel piece backward while lifting it up over the heel lock. To replace the heel pieces, follow the removal procedure in reverse and tighten the rear mounting screws securely.

BINDING MAINTENANCE & REPAIR (continued)

Acceptable Use of Cants

Atomic or Salomon bindings should not be altered in any way except as explicitly outlined in this manual.

The use of cants with Atomic or Salomon bindings is acceptable, provided:

- The cants are of a high grade material designed for this use.
- The cants are installed in a professional manner.
- Proper screw penetration into the ski meets current norms.
- The cants do not impede the binding's function as it was designed, including proper function of the brake.

AFD Replacement

All Atomic and Salomon bindings have replaceable AFDs. The specific AFD item numbers can be found in the **Spare Parts catalog (page 48)**, though some AFD Reference Numbers are listed in the chart below, and the AFD part reference numbers for all current model bindings is listed in the **Quick Reference Chart on pages 7 and 8**.

Replacement procedures for AFDs are as follows.

General AFD Replacement

1. Dismount the toe piece from the interface or from the ski.
2. Remove the AFD from the toe piece baseplate.
3. Position the replacement AFD on the baseplate and press it into place.
4. Remount the toe piece.

Ejectable Anti Friction Plate Replacement

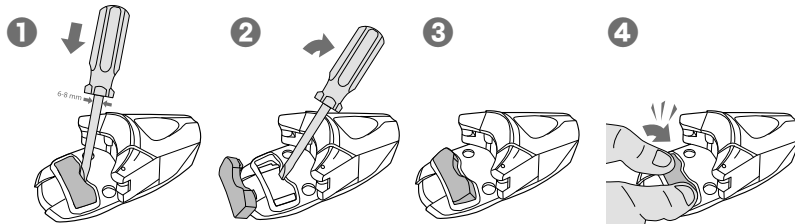

Some models have an anti friction plate that is removable without dismantling the toe piece.

1. Insert a 6-8 mm wide screwdriver at the front of the plate. **Fig. 1**
2. Move over the screwdriver to eject the plate. **Fig. 2**
3. Place the new plate and hand clip it. **Fig. 3 & 4**

Caution: for models with elastic pedal (range 08), check the presence of the elastic block under the pedal. **Fig. 5**

AFD Replacement on Moveable Toe Smartrak Systems

For Moveable Toes mounted on Smartrak

1. Remove the Toe Piece from the Interface.
2. Dismount the Toe piece from the Set by completely loosening the mounting screws.
3. Dismount manually the AFD+Stirrup on the toe piece.
4. Take the new Set AFD+Stirrup and mount it manually under the Toe piece.
5. Tighten the Toe piece on the Stirrup (4 N-m torque).
6. Remount the Toe piece on the Interface.

REFERENCE

Page #	Section Name
45	Standard Boot Sole Dimensions

PARTS (see page 48)

Reference #	Item Name
L10056700	AFD for Jr Bindings: Atomic EVOX 045, FFG 7, Salomon C5, L7
L78830100	Gliding AFD for Salomon Z (all) and STH 10, & Atomic FFG 12 and 10
AZD000056	Gliding AFD for Salomon Z (all) and STH 10, & Atomic FFG 12 and 11
L78829599	AFD & Baseplate: Smartrack Salomon Z (all) & Atomic XTO (all)

CERTIFICATION EXAM

The technician who signs the Authorized Dealer's workshop or rental form for any transaction must be currently certified

TECHNICIAN CERTIFICATION EXAM

2013/2014 Technician Certification Exam Questions

Do not write on this form. Indicate answers on the Registration Form.

A score of 90%, or 23 correct answers, must be obtained to pass. In addition, questions 12 to 25 are considered core questions and must be answered correctly.

1 Indemnified Bindings are:

- a) The 2013/2014 models only.
- b) Not something a technician needs to know about.
- c) Those that appear on the 2013/2014 Schedule of Indemnified Bindings in the Atomic and Salomon Shop Practices Manual.
- d) Any Atomic or Salomon binding still in use.

2 A mechanical testing device:

- a) Gives consistent results even when it is operated incorrectly.
- b) Never needs re-calibration.
- c) Requires properly trained technicians for consistent results.
- d) Is only used in rental shops.

3 A Post Accident Ski Equipment Inspection Report form:

- a) Is a critical tool in defending liability claims.
- b) Is only necessary in the case of lower body injuries.
- c) Must be completed each time an accident is reported.
- d) Answers a) and c).

4 If the mid-sole indicator on an Atomic or Salomon jig and the mid-sole indicator on a boot do not agree, you should:

- a) Position the jig by splitting the difference between the two marks.
- b) Not install the binding.
- c) Leave the boot in the jig and use the mid-sole mark on the boot to position the jig on the ski.
- d) Use the mid-sole mark on the jig to position it on the ski.

5 What is Skier Type?

- a) A person who enjoys skiing.
- b) The degree of skill a skier possesses.
- c) A classification system based on skiing preferences, not skier ability, and is the skiers responsibility to determine.
- d) Unnecessary information.

6 Atomic and Salomon Technician Certification:

- a) Does not require that Certified Technicians be familiar with Atomic and Salomon Bindings through hands-on experience.
- b) Is valid for 2 years from the exam date and may be transferred between Authorized Alpine Binding Dealers.
- c) Never has to be renewed. Once you've past the exam.
- d) Is valid whether or not the employer is an Authorized Alpine Binding Dealer.

7 When adjusting the toe height on Atomic Evox bindings, you should:

- a) Check your adjustment with a toe height card.
- b) Use an adjustment tool for the toe height screw.
- c) Answers a) and b).
- d) None of the above; toe height adjustment is automatic.

8 Mechanical inspections of rental equipment:

- a) Ensure that all components are functioning properly.
- b) Are required periodically in-season.
- c) Are required pre-season .
- d) All of the above.

9 When a skier picks up their equipment from your shop make sure:

- a) Someone explains the use of the equipment to them and provides them with signed copies of the Workshop/Rental Form and Liability Release Agreement.
- b) They speak with the technician who did the installation/adjustment.
- c) You wish them luck.
- d) You only hand it over to the intended user.

10 Workshop or Rental Forms must:

- a) Be signed by the customer and the Certified Technician.
- b) Be used for every transaction.
- c) Be kept on file for 5 years or for the statute of limitations.
- d) All of the above.

11 When is the forward pressure correct on the Atomic FFG 16, and Salomon STH 12, 14 & 16?

- a) Place boot in binding and center with mid boot mark.
- b) When the boot is in the binding and the top of the head screw is aligned with the back of the heel track.
- c) When the boot in the binding, adjust DIN number.
- d) There's no need for adjustment it is automatic.

12 What should the visual indicator setting be for a skier who weighs 70 kg, height 153 cm, boot sole length 306 mm, skier Type II, age 59?

- a) 3 b) 3.5
- c) 4.5 d) 5.5



Photo: Scott Markewitz

TECHNICIAN CERTIFICATION EXAM (continued)

2013/2014 Technician Certification Exam Questions (continued)

- 13 What is the correct maintenance procedure for an Atomic or Salomon binding?**
- You may use any solvent or high pressure liquids to clean bindings.
 - None of the above.
 - Cleaning all exposed area of the components with a cloth or rag, cleaning binding housing, heel tracks and apply grease.
 - Bindings are self cleaning and do not need maintenance at any time.
- 14 Examples of Salomon bindings that may be used with both junior & adult boot sole norms are:**
- Atomic FFG 16 & Salomon STH 12
 - Atomic FFG 10 & Salomon Z10
 - Atomic FFG 7 & Salomon C5
 - You can't use an adult norm sole with a Salomon junior binding.
- 15 If there are no manufacturer's recommendations for drill bit selection you should:**
- Drill one hole with a 3.6 mm bit and check for metal before switching to a 4.1 mm bit.
 - Always use a 4.1 mm bit, all mounting platforms contain metal.
 - Drill the ski with the bit in your drill, you can't go wrong.
 - Use a 3.6 mm bit, you can always increase the torque on the screw-shooter.
- 16 Skiers requesting personal settings higher or lower than are indicated by the 2013/2014 Adjustment Chart should:**
- Be instructed to adjust their bindings themselves.
 - Be asked if they wish to identify themselves as Type III+ or Type -I and use the indicated settings.
 - Be given the settings they want provided they sign a Requested Setting Release Agreement.
 - Answer b) or c).
- 17 The Atomic Tracker or Salomon Guardian Binding is intended to be used:**
- with ski boots equipped with WTR Technology.
 - with heels unlocked for more forward lean while skiing.
 - with alpine ski boots compliant with ISO 5355 Standard.
 - Answers a) & c).
- 18 A skier weighs 185 lb and measures 5'11" tall. He is a Type I skier who is 51 years old. What is his Skier Code on the Chart?**
- L
 - K
 - J
 - I
- 19 A boot is considered incompatible with an Atomic or Salomon binding if:**
- There is more than a 1 mm difference in sole flatness across its width.
 - It does not conform to Standard Boot Sole Dimensions.
 - It does not pass visual inspection.
 - All of the above.
- 20 WTR Technology was designed to:**
- improve edgегrip.
 - be used with adult or junior norms.
 - provide skiers the walking ease and comfort of a touring boot combined with the confidence and performance of an alpine set up.
 - match your jacket.
- 21 You are testing a used boot-binding system on a mechanical testing device. The binding has a visual indicator setting of 5.5 and the boot sole is 307 mm long. What is the In-use Range for twist?**
- 37 to 67 N-m
 - 43 to 58 N-m
 - 50 N-m
 - 141 to 271 N-m
- 22 If the forward pressure indicators on the heel are not aligning properly you should:**
- Remove the boot and move the heel forward or back to correct.
 - Make sure (adjustable) toe wings and toe height are correct.
 - Ignore it if they are close.
 - Answers a) & b).
- 23 What should the initial visual indicator setting be for a 215 lb, 6'6", Type III+ skier who is 26 years old and uses boots with a sole length of 305 mm?**
- 11
 - 11.5
 - 12
 - Not possible to determine.
- 24 An eight year old is being fitted for her first pair of skis. She weighs 42 lb. What Skier Code would you use to help determine the visual indicator setting of her bindings?**
- Skier Code 1
 - Skier Code 2
 - Skier Code B
 - Skier Code C
- 25 When testing the toe for elastic travel and return, the boot should:**
- Elastic travel only occurs while skiing and cannot be tested in the shop.
 - Move off center at least 5 mm and return to within 2 mm of its original position.
 - Move slightly off center then release completely.
 - None of the above.

On-line Registration Instructions

Applying technicians must complete the 2013/2014 Atomic or Salomon on-line certification registration and test. A score of at least 90% (23 correct answers) must be achieved to pass the exam. Applying technicians are not certified until a passing score is achieved.

• **U.S. dealers** will find the on-line certification registration and test at: <http://www.salomoncertification.com>

• For the U.S., a \$12 fee will be invoiced for each Registration and Exam submitted on line at www.salomoncertification.com

• The U.S. fee is \$20 for each Registration/Exam submitted by mail or fax to Atomic or Salomon, or for technicians certified by any approved industry training program.
 Fax: (801) 334-4502
 Technician Certification/Customer Service
 Amer Sports Winter & Outdoor Company
 2030 Lincoln Ave
 Ogden, UT 84401

• **Canadian dealers** will find the on-line certification registration and test at: <http://www.salomonhookup.ca> or <http://www.atomiccanada.net>



2013/2014 ADJUSTMENT CHART

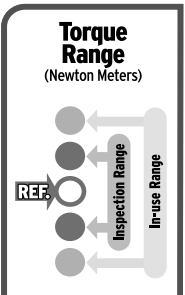

Skier			Initial Toe/Heel Indicator by Boot Sole Length (mm)								Twist	Forward Lean
Weight lb/kg	Height ft-in/cm	Skier Code*	≤ 230 mm	231- 250 mm	251- 270 mm	271- 290 mm	291- 310 mm	311- 330 mm	331- 350 mm	≥ 351 mm	5	18
22-29 lb 10-13 kg		A	3/4	3/4	3/4						8	29
30-38 lb 14-17 kg		B	1	3/4	3/4	3/4					11	40
39-47 lb 18-21 kg		C	1 1/2	1 1/4	1 1/4	1					14	52
48-56 lb 22-25 kg		D	2	1 3/4	1 1/2	1 1/2	1 1/4				17	64
57-66 lb 26-30 kg		E	2 1/2	2 1/4	2	1 3/4	1 1/2	1 1/2			20	75
67-78 lb 31-35 kg		F	3	2 3/4	2 1/2	2 1/4	2	1 3/4	1 3/4		23	87
79-91 lb 36-41 kg		G		3 1/2	3	2 3/4	2 1/2	2 1/4	2		27	102
92-107 lb 42-48 kg	≤ 4'10" ≤ 148 cm	H			3 1/2	3	3	2 3/4	2 1/2		31	120
108-125 lb 49-57 kg	4'11"-5'1" 149-157 cm	I			4 1/2	4	3 1/2	3 1/2	3		37	141
126-147 lb 58-66 kg	5'2"-5'5" 158-166 cm	J			5 1/2	5	4 1/2	4	3 1/2	3	43	165
148-174 lb 67-78 kg	5'6"-5'10" 167-178 cm	K			6 1/2	6	5 1/2	5	4 1/2	4	50	194
175-209 lb 79-94 kg	5'11"-6'4" 179-194 cm	L			7 1/2	7	6 1/2	6	5 1/2	5	58	229
≥ 210 lb ≥ 95 kg	≥ 6'5" ≥ 195 cm	M				8 1/2	8	7	6 1/2	6	67	271
		N				10	9 1/2	8 1/2	8	7 1/2	78	320
		O				11 1/2	11	10	9 1/2	9	91	380
		P						12	11	10 1/2	105	452
											121	520
											137	588

* Based on "Type I" Skier aged between 9 and 50 years old.

TECHNICIAN CERTIFICATION ANSWER FORM

2013/2014 Technician Certification Answer Form

This form is for U.S. dealers only.

Get all your certification needs at www.atomiccertification.net or www.salomoncertification.com



Fees

On line certification test: \$12

Faxed or mailed test: \$20

Technician & Store Information

EXAM DATE

TECHNICIAN'S NAME (PRINT CLEARLY)

STORE ACCOUNT #

STORE NAME

SHOP PHONE #

STORE ADDRESS

Instructions

Please print clearly your information above and fax or mail your Certification Answers to (801) 334-4502.

A score of 90%, or 23 correct answers, must be obtained to pass.

In addition, questions 12 to 25 are considered core questions and must be answered correctly.

Please circle your answer for each question.

All answers must be clearly marked. Any partially circled answers could be marked incorrect.

Answer Section

- | | | | | | |
|-----------|-----------|-----------|-----------|-----------|-----------|
| ① a b c d | ⑥ a b c d | ⑪ a b c d | ⑬ a b c d | ⑰ a b c d | ⑲ a b c d |
| ② a b c d | ⑦ a b c d | ⑫ a b c d | ⑭ a b c d | ⑱ a b c d | ⑳ a b c d |
| ③ a b c d | ⑧ a b c d | ⑬ a b c d | ⑮ a b c d | ㉑ a b c d | ㉒ a b c d |
| ④ a b c d | ⑨ a b c d | ⑯ a b c d | ⑲ a b c d | ㉓ a b c d | ㉔ a b c d |
| ⑤ a b c d | ⑩ a b c d | ⑰ a b c d | ㉑ a b c d | ㉕ a b c d | ㉖ a b c d |

MAIL OR FAX TO:

Technician Certification/Customer Service
 Amer Sports Winter & Outdoor Company
 2030 Lincoln Ave., Ogden, UT 84401
 Fax: (801) 334-4502
 Phone: 1 (800) 654-2668

TECHNICIAN'S SIGNATURE

SIGNATURE DATE

ALPINE SKI TECHNICAL FEATURES

Ski Technical Length and Midsole Mark Chart

Brand	Model	Article Number	Length (cm)	Midsole* (cm)
Atomic	REDSTER JR III	AA0024336*	130	53.5
			140	58.5
			150	63.5
Atomic	Vantage jr. III	AA0024412*	130	53.5
			140	58.5
			150	63.5
Atomic	Rascal I	AA0024386*	70	30
Atomic	REDSTER JR I	AA0024344*	70	30
Atomic	Affinity jr. I	AA0024284*	70	30
Atomic	REDSTER JR II	AA0024340*	90	36.5
			100	40.5
			110	45
Atomic	Vantage jr. I	AA0024408*	70	30
			90	36.5
			100	40.5
Atomic	Vantage jr. II	AA0024410*	110	45
			120	48.5
			130	51.5
Atomic	Rascal II	AA0024390*	90	36.5
			100	40.5
			110	45
Atomic	ETL	AA0024350*	135	54.5
			145	59.5
			155	64.5
Atomic	Blackeye TI	AA0024244*	160	58
			167	71.5
			174	75
Atomic	Punx Jr III	AA0024394*	140	56
			150	71.5
			160	71.5
Atomic	Century jr. III	AA0024288*	140	56
			150	71.5
			160	71.5
Atomic	Trooper	AA0024370*	150	74
			170	82
			177	85
Atomic	RITUAL	AA0024380*	174	78
			182	82
			190	86
Atomic	Automatic	AA0024372*	179	78
			186	82.5
			193	86
Atomic	ALIBI	AA0024382*	173	80
			180	83.5
			187	87
Atomic	Punx	AA0024368*	155	78
			173	87
			182	91
Atomic	Bent Chetler	AA0024374*	183	89.5
			192	94
			199	98
Atomic	Millennium	AA0024450*	161	78.5
			169	82
			177	86.5
Atomic	Blog	AA0024376*	161	78
			169	82.5
			177	86.5
Atomic	Atlas	AA0024354*	182	79
			192	84
			199	88
Atomic	Supreme	AA0024296*	149	67
			157	73
			165	77
Atomic	PANIC	AA0024416*	149	69
			157	73
			165	77

Brand	Model	Article Number	Length (cm)	Midsole* (cm)
Atomic	Access	AA0024378*	151	66.5
			161	71.5
			171	76.5
Atomic	Century	AA0024298*	181	81.5
			191	86.5
			196	88.5
Atomic	Charter	AA0024356*	146	61
			156	66
			166	71
Atomic	Bent Chetler Mini	AA0024398*	133	63
			143	68
			153	73
Atomic	Century jr. II	AA0024292*	110	50.5
			120	55
			130	59.5
Atomic	Punx Jr II	AA0024400*	110	50.5
			120	55
			130	59.5
Atomic	Theory	AA0013960*	168	79.5
			177	84
			186	88.5
Atomic	Elysian	AA0024294*	150	70.5
			159	75
			169	79.5
Atomic	Drifter	AA0024358*	164	74.5
			173	79
			182	83.5
Atomic	Free Dream	AA0024360*	157	63.5
			164	67
			171	70.5
Atomic	Descender	AA0024362*	136	63
			163	66.5
			170	70
Atomic	Ultimate	AA0024364*	137	66.5
			158	67
			164	70
Atomic	Aspect	AA0024366*	170	73
			176	76
			182	79
Salomon	N Q-115 Green/White	L35453200*	198	77.9
			173	82.4
			188	87.7
Salomon	N Q-105 NA Bordeaux/BR/BK	L35453300*	187	75.7
			174	79.6
			181	83.5
Salomon	N Q-98 NA Blue/WHITE/Black	L35453400*	188	87.4
			156	70.2
			164	74.4
Salomon	N Q-90 NA Red/Black/White	L35453500*	172	78.7
			189	83.5
			197	87.7
Salomon	N Q-103 Stella White/PR/BL	L35495300*	185	82
			159	72.7
			165	75.7
Salomon	N Q-96 Lumen White/PR/TQ	L35495400*	172	79.6
			179	83.5
			182	74.4
Salomon	N Q-88 Lux White/Orange/PK	L35495500*	170	77
			178	83
			151	65.3
Salomon	N Rocker* 122 Black/BL/WH	L35479700*	159	69.3
			167	73.5
			180	84

Brand	Model	Article Number	Length (cm)	Midsole* (cm)
Salomon	N Rocker* 108 White/BL/BK	L35480300*	166	73.5
			174	83.5
			182	87.5
Salomon	N Rockette Red/Black/White	L35496600*	156	75.5
			164	79.5
			172	83.5
Salomon	N Remix Red/Blue/White	L35480700*	163	80.3
			171	84.3
			178	88.2
Salomon	N Suspect Rld Green/White	L35483400*	151	69.2
			161	74.2
			171	79.2
Salomon	N Threat Blue/Orange/White	L35483900*	141	66.1
			151	70.8
			161	75.3
Salomon	I X-Race + Race plate XX B	L35366800*	170	72.74
			175	76.94
			180	78.94
Salomon	K 24 Hours Max K212 B80	L35524100*	154	64.6
			170	73.2
			178	77.6
Salomon	K 24 Hours Pro + K210 B80	L35524200*	148	61.1
			155	64.8
			160	68.6
Salomon	K Enduro XT 850 NA + K212	L35525400*	163	70.2
			170	74
			177	78
Salomon	N Enduro XT 850 NA YE/BK	L35645700*	163	70.2
			170	74
			177	78
Salomon	K Enduro XT 800 NA + K212	L35525600*	154	65.5
			161	69.3
			168	73.1
Salomon	N Enduro XT 800 NA WH/GR/B	L35645800*	162	71.1
			175	77.1
			182	81.1
Salomon	K Enduro RS 600 TI NA+K212	L35525800*	149	62.8
			156	66.6
			163	70.4
Salomon	K Enduro RS 800 NA + K210	L35526000*	144	60.4
			152	64.2
			160	68.8
Salomon	H Bamboo K210 TI W B80 W	L35269900*	155	66.6
			162	70.4
			169	74.2
Salomon	E Lava + EL10 W B80 BK/RD	L35527100*	151	65.4
			159	69.6
			167	73.9

Brand	Model	Article Number	Length (cm)	Midsole* (cm)
Salomon	E Pure White + EL10 W B80	L35527500*	143	61.2
			151	65.4
			159	69.6
Salomon	N BBR 10.0 Brown/Black	L35449400*	170	78
			177	80
			184	83
Salomon	N BBR 9.0 Green/Brown	L35449500*	166	74
			176	78
			186	83.6
Salomon	N BBR Sunlite CORAIL/WOOD	L35484000*	149	66
			159	71
			169	77
Salomon	E BBR Starlite + EL10 W B8	L35526600*	155	69.2
			165	73.8
			170	76.8
Salomon	N Rocker* Jr Black/Blue/WH	L35496700*	130	61.6
			140	66.6
			150	71.6
Salomon	N Suspect Jr Green/White	L35497200*	110	48.7
			120	53.2
			130	57.7
Salomon	E Q-Max Jr M + EL7 B80 RD	L35528600*	130	53.5
			140	58.5
			150	63.5
Salomon	E Q-Max Jr S + EC5 J75 RD	L35528700*	100	40
			120	50
			120	50
Salomon	E Q-Max Jr XS + EC5 J75 WH	L35528800*	70	30
			80	33
			90	36.5
Salomon	E Q-Lux Jr M + EL7 B80 WH	L35529000*	130	53.5
			140	58.5
			150	63.5
Salomon	E Q-Lux Jr S + EC5 J75 WH	L35529100*	100	40
			110	45
			120	50
Salomon	E Q-Lux Jr XS + EC5 J75 WH	L35529300*	70	30
			80	33
			90	36.5
Salomon	NR Q-90 R Red/Black/White	L35497700*	161	69.3
			169	73.5
			177	77.7
Salomon	E Enduro LX 750 R + EL10 B	L35530100*	144	60.4
			152	64.2
			160	68.8
Salomon	FR Focus + L10 SC B80 BK/BL/Y	L35991300*	125	55.6
			135	54.5
			145	53.5
Salomon	E Sun R + EL10 W B80 WH/OR	L35530200*	155	64.5
			165	69.5
			175	74.5
Salomon	E BBR Limelite R + EL10 W	L35530000*	136	58.1
			143	61.2
			151	65.4

* measured from ski tail

Photo: Scott Markewitz

Drill Bit Selection For Atomic and Salomon Skis

Ski Model	Ski Size	Drill Bit Diameter	Tapping	Glue*	Torque
Junior	>= 140 cm	4,1 mm (only for skis with metal)	No	No	4 Nm
	All sizes	4,1 mm (only for skis with metal)	No	Salomon glue or epoxy	

* Place a drop of glue on the surface of each hole.

Mounting Warning

Atomic and Salomon do not recommend that any binding outside industry standards be mounted on any Atomic or Salomon ski.

Recommendations For Use of Skis According to the Mass of Skier

To guarantee the sufficient parameters of safety (i.e. the resistance of the screws to wrench), skiers must use skis, according to groups 1 to 4 (see table), corresponding with their weight**.

Group of Ski	Skier Weight (kg)
1	greater than 65 kg
1, 2	65 kg or less
1, 2, 3	45 kg or less
(1, 2) 3, 4	25 kg or less

** Extract from NF ISO 8364 June 2007

ALPINE BOOT

Technical reference for the complete line of Atomic and Salomon boots.

STANDARD BOOT NORMS

Standard Boot Sole Dimensions > ISO 5355

Boot soles are standardized and bindings are designed accordingly.

The standard norm concerns not only the shape and dimensions as illustrated, but also the friction coefficient of the area of the sole which is in contact with the anti-friction plate on the binding.

In practical terms:

Boot manufacturers who display one of the following markings: DIN, ISO, ÖN, UNI guarantee that they use standard norms.

In the absence of any of these, check first with the boot manufacturer.

Alpine norm ISO 5355: Designed for use with a pair of classic skis with alpine bindings and not with a monoski, snowboard or skiboard.

Touring norm ISO 9523: Designed for use with a pair of touring bindings, and not with alpine bindings, monoski, snowboard or skiboard.

It is the skier's own responsibility if (s)he chooses to take the additional risks.

When a pair of used boots is brought in, make sure that any worn parts are still within the norm.

Your ski boots must be assembled, adjusted, and checked by an authorized dealer.

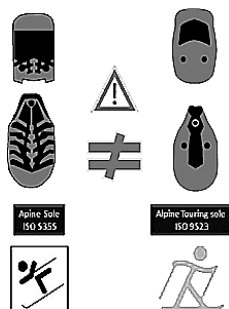

BOOT TOE (ISO 5355)

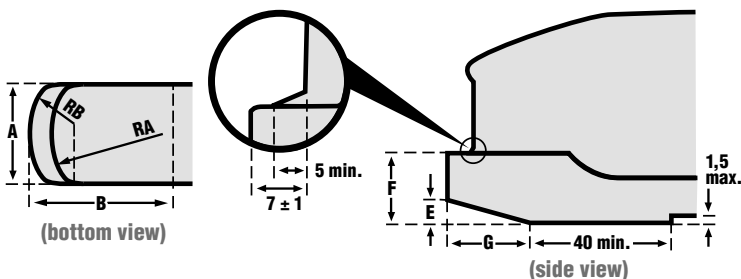

LEGEND (measurements in mm)

	Adult boot	Junior boot
A	69 ± 2	62 ± 2
B	70	65
C	70	50
D*	100 (L < 300 mm) 120 (L ≥ 300 mm)	80 (L < 240 mm) 90 (L ≥ 240 mm)
E	5 ± 1	3 ± 1
F	19 ± 1	16.5 ± 1.5
G	30 ± 2	25 ± 2
H	30 ± 1	27.5 ± 2
I	4 ± 1	3 ± 1
RA	41.5 ± 3.5	35 ± 3
RB	18 ± 1.5	16 ± 2
RC	37 ± 4	27 ± 3
RD	36.25 ± 0.75	34.5 ± 1

BOOT HEEL (ISO 5355)

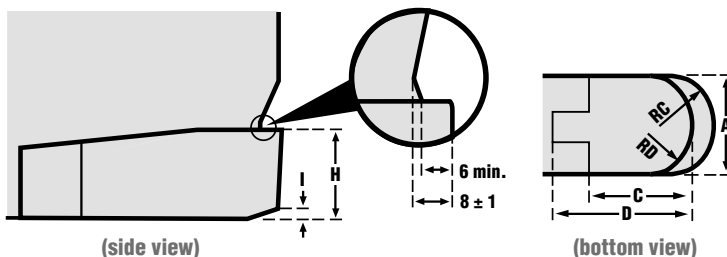

*L = boot sole length

Boot Modification

Any performance or fit modification of a boot that could effect the function between the boot and binding should be inspected to verify that the boot meets Standard Alpine Boot Norms. Mechanical Inspection is recommended after any such modification.

TECHNICAL FEATURES

Boot Sole Lengths

Brand	Models	Mondopoint Sizes																		
		15	16	17	18	19	20	21	22	23	24	25	26	27	28	29	30	31	32	33
		22.5	23.5	24.5	25.5	26.5	27.5	28.5	29.5	30.5	31.5	32.5	33.5							
Atomic	Redster Pro								266	275	285	295	305	315	325	335				
Atomic	Redster WC								266	275	285	295	305	315	325	335				
Atomic	Medusa								266	275	285	295	305	315	325	335				
Atomic	Tracker										285	295	305	315	325	335				
Atomic	Hawx								265	275	285	295	305	315	325	335	355			
Atomic	Live Fit								269	279	289	299	309	319	329	339	349	369		
Atomic	Junior (junior norms)				237	237	247	257												
Atomic	Junior (adult norms)								267	277	287	297	307							
Salomon	X Lab										275	285	295	305	315	325				
Salomon	X Max											285	295	305	315	325	335			
Salomon	X Max Women								265	275	285	295	305	315						
Salomon	X Pro										286	296	306	316	326	336	356	356	376	
Salomon	X Pro Women								266	276	286	296	306	316						
Salomon	Mission											298	307	317	328	339	350	360		
Salomon	Divine								268	278	288	298	307	317						
Salomon	Quest Max											285	295	305	315	325	335			
Salomon	Quest Max BC											285	295	305	315	325	335			
Salomon	Quest											288	298	308	318	328	338	358	358	
Salomon	Quest Women								278	278	288	298	308	318						
Salomon	Quest Access											288	298	308	318	328	338	358	358	
Salomon	Quest Access Women								278	278	288	298	308	318						
Salomon	Ghost Max											285	295	305	315	326	336			
Salomon	SPK								267	277	287	297	307	317	327	337				
Salomon	X Max LC								265	275	285	295	305	315						
Salomon	Quest Access T								265	275	285	295	305	315						
Salomon	X3 60 T				240	240	247	257	267	277	287	295	307							
Salomon	T3 / Team								266	276	285	296	306							
Salomon	T2 / Team				240	240	247	259												
Salomon	T1	208	208	223	223															
Salomon	Focus / Focus Women											277	287	297	307	317	327	337	357	357
Salomon	Symbio								263	275	284	296	306	317	326	336	345			

Mondopoint Size Equivalents

Mondopoint (MP) is a measuring system for boots that states the length of the foot in metric measurements. This means that a 27 cm long foot has an MP measurement of 27. The advantage of this system is that the different terms for size such as size in England and the USA and Stich in France are standardised.

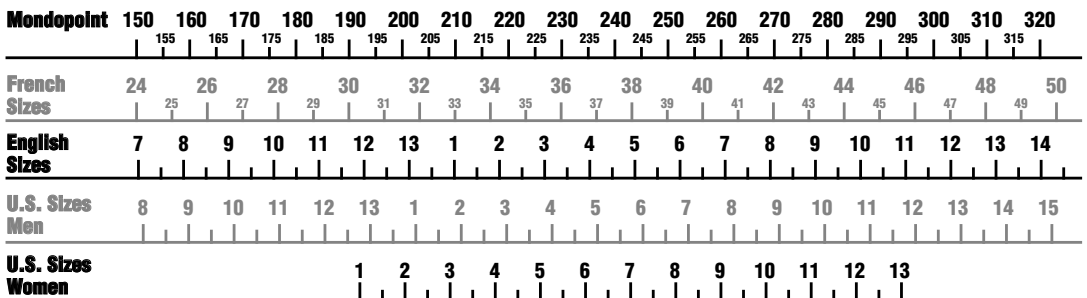

CANTING AND LIFTERS

Canting on X LAB OP, X MAX and Quest Max

Canting could be adjusted by following operations :

- Internal boot sole grinding
- Chassis grinding on X MAX 130 model
- 4mm canting lifters kit available for X MAX 120 and 100 models:
- This kit allows an adjustment of +/- 0.7° in function of the lifter side mounting
- Maximum screwing value: 0.8 N·m
- Maximum assembly/ disassembly: 5 times



Lifters On X MAX 120 And 100

4mm lifters are removable and should be replaced if excessively worn and/or damaged. Salomon guarantees the lifters for their disassembling and reassembling, up to a maximum of 5 times subject to strict compliance with the following instructions: Use only a manual screw driver. Unscrew the 12 screws and remove them from the lifter. Remove the rear and front sole. Push them forward towards the front of the shell and rescrew using a maximum of 0.8 N·m of torque, as mentioned on the lifters.

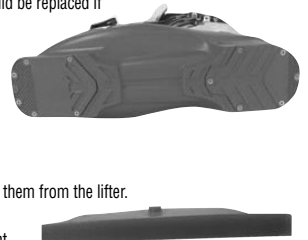

Cantable Alpine Pads

Available as spare part, Cantable Alpine Pads are compatible with following models : XPro / Ghost Max / Quest / Quest Access / Ghost Max.

Warning: Cantable Alpine Pads must be ground before using to reach compliance with ISO 5355 norms. Grinding should be done with the same angle, on both the top and bottom of the Cantable Alpine Pad, in order to guarantee that both surfaces are parallel (Fig. 1).

Grinding on the top and bottom surfaces should not go beyond the reference lines marked on Cantable Alpine Pads. A canting angle of 0 to 1.5° can thus be obtained (Fig. 2).

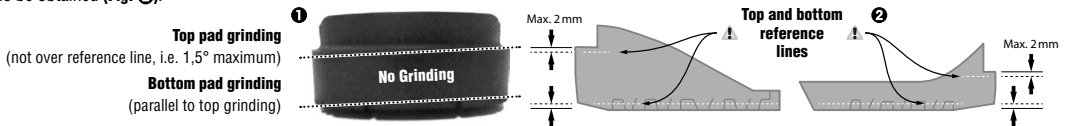

Walk Soles and Walk Soles+

Walk Soles & Walk Soles+ are compatible with following models : XPro / Ghost Max / Quest / Quest Access / Ghost Max.

These walking sole pads are intended to be used only with the following bindings:

- Touring bindings compliant with ISO 13992 standard
- "WTR technology" labeled alpine bindings compliant with ISO 9462 standard

Any use with other bindings is not recommended.

These walking soles are removable and should be replaced if excessively worn and/or damaged.

Salomon guarantees the soles for their disassembling and reassembling, up to a maximum of 5 times subject to strict compliance with the following instructions:

- Use only a manual screw driver.
- Unscrew the 7 screws and remove them from the sole.
- Remove the rear and front sole.
- Slide the rear sole forward and the front sole backwards onto the shell and rescrew using 1.5 N·m of torque.

WALK SOLES WITH LOW TECH INSERTS

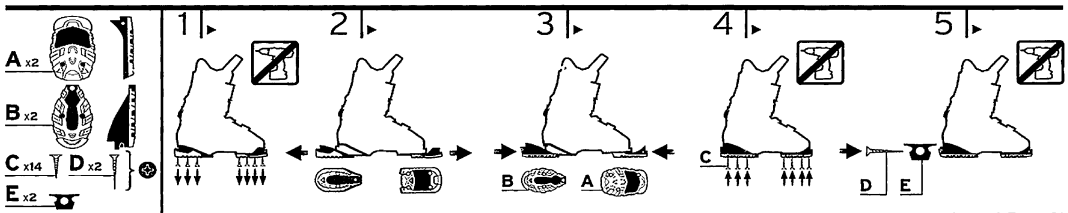
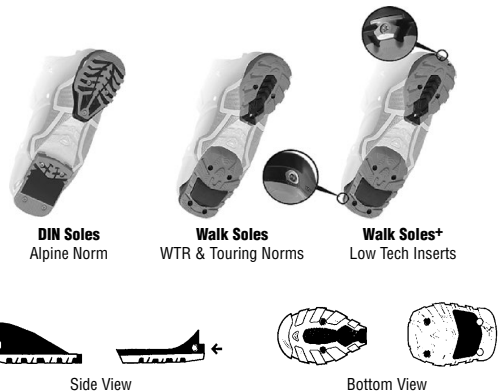



SPARE PARTS – CONTENTS

ALPINE BINDING	49
ALPINE SKIS	53
ALPINE GOGGLES	54
POLES & HELMETS	55
ALPINE BOOTS	55
NORDIC SKI	60
SNOWBOARD BINDINGS	62
SNOWBOARD BOOTS	63
FOOTWEAR	63

This catalogue is for product display only. Prices are subject to change at anytime. Atomic and Salomon reserve the right to modify or discontinue any product. Every product not available in all countries. Atomic and Salomon reserve the right to limit or to modify color and/or aesthetic versions of spare parts. These spare parts will nonetheless continue to be distributed in their original functions.

All rights reserved. Any reproductions, partial or in full, are prohibited.

ALPINE BINDINGS

Track

			Ref.	\$ Price
	1X2	Base Plate Smartrak Protrak & Smartrak Control + Z & XTO	AZD000152	\$ 20.00
			L78829500	\$ 20.00
	1X2	SC / ++ Toe Baseplate Track (Adult)	L7837850001	\$ 9.00
	1X2	SC / ++ Toe Baseplate Track (Junior)	L7837870001	\$ 9.00

Adjustable Toe Base Plate

			Ref.	\$ Price
	1X2	Z Speed Lever	L1202700001	\$ 7.00

Toe Track

			Ref.	\$ Price
	1X2	Toe "T" for all current Z, FFG and Oversize 3 hole toes	L7882970001	\$ 4.75
	1X2	Toe "T" for Smartrak, Protrak, and Smartrak Control	L7882980001	\$ 4.75
	1X2	Toe Insert for Junior bindings TZ5, L7, EVOX 7 / EVOX 045	AZD000034	\$ 4.75
			L5483390001	\$ 4.75
	1X2	Toe Insert for Adult bindings (L10, L9, FFG 7)	L1006190001	\$ 4.75

Position Indicator

			Ref.	\$ Price
	1X2	Toe Position Indicator (all ++ and SC products)	AZD000022	\$ 4.00
			L7838580001	\$ 4.00

Central Plate

			Ref.	\$ Price
	1X2	Smartrak Central Strip Rental	L1005660001	\$ 9.00
	1X2	Lightrak Senior Central Strip HL	L1083290001	\$ 9.00

Heel Guide Or Heel Track Housing

			Ref.	\$ Price	
	1X2	Plastic Heel Guide Housing for all Heels except Salomon STH and Atomic FFG 16 Team	L0011730001	\$ 5.00	
	1X2	Plastic Heel Guide Housing for Adult SR Models	268-348 mm	L7837950001	\$ 6.00
	1X2	Plastic Heel Guide Housing for Junior SC Models	216-304 mm	<u>L7837930001</u>	\$ 2.00

Track

			Ref.	\$ Price	
	1X2	Easytrak Brake Plate	L3663710001	\$ 10.00	
	1X2	SC Adult Heel Track Base Plate	260-382 mm	L1203010001	\$ 13.00
	1X2	Steel Heel Track	L3084250001	\$ 13.00	

Rental Stickers

			Ref.	\$ Price
	2X10	SC Senior Rental Stickers	L3084270001	\$ 10.00
	4X5	Stickers (pairs) Easytrak XS - S - M - L	L3512160001	\$ 5.00

Lever

			Ref.	\$ Price
	1X2	Heel Lever (Squared Newer)	L3084260001	\$ 8.00

↑
Parts Count

↑
Reference





How to read the tables

04 year 230-308 mm dimensions (T175): size ##### while quantities last ##### New



Backcountry

			Ref.	\$ Price
	1X2	Backcountry Plate Axis Screw	L3663720001	\$ 4.00
	1X2	Backcountry Front Plate	L3663730001	\$ 5.00
	1X2	Backcountry Crampon	C105	L3516380020 \$ 50.00
			C115	L3516380025 \$ 50.00



Anti Friction Plate

			Ref.	\$ Price
	1X2	3 hole toe gliding AFD (FFG 12, FFG 10, Z Series Bindings and STH10)	AZD000056	\$ 7.50
			L7883010001	\$ 7.50
	1X2	Junior Evox 045, FFG7, L5 - C5 - EC5 - LZ 7-8-9 - L10 - L10 SR - EL10 - EL9 - EL7	L1005670001	\$ 4.00
	1X2	AFD for STH Oversize Z Toes	L5483410001	\$ 5.00
	1X2	AFD for STH 16 & FFG 16 Team	L5483420001	\$ 6.00
	1X2	AFD for STH 14 Driver and STH 12 Driver	L1044750001	\$ 6.00
	1X2	AFD for Z Speed and Backcountry (all models)	L1202730001	\$ 7.00
	1X2	Housing Plate STH2	L3567860001	\$ 6.00

Toe Housing

			Ref.	\$ Price
	1X2	Silver Z Toe Housing cover (all Models)	L7885600001	\$ 10.00
	1X2	Silver Z Oversize Toe Housing Cover (all Models)	L1083320001	\$ 10.00
	1X2	Toe Housing all XTO Products	AZD000160	\$ 10.00

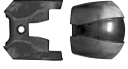
Brake

			Ref.	\$ Price
	1X2	Brake Junior (T5, T5 SR) (07)	L5483430001	\$ 12.00
	1X2	Brake Junior SC (T5 SC, T5 Juniortrak) (07)	L1005530001	\$ 10.00
	1X2	Junior (C5 Easytrak)	L3084310001	\$ 10.00
	1X2	Junior J85 (T5, T5 SR)	L3084280001	\$ 10.00
	1X2	Junior J85 (045++/T5 SC)	L3084290001	\$ 10.00
	1X2	Junior J85 (C5 Easytrak)	L3084300001	\$ 10.00
	1X2	Brake R & S 80 DG X 100	L7857550001	\$ 15.00
	1X2	Brake R & S 90 DG X 100	L7857570001	\$ 10.00
	1X2	Brake R & S 100 DG X 100	L7857580001	\$ 10.00
	1X2	Brake R & S 115 DG X 100	L7857590001	\$ 15.00
	1X2	Brake R & S 130 DG X 100	L7885570001	\$ 15.00
	1X2	Brake B75 DG X 100	L7857450001	\$ 15.00
	1X2	Brake B80 DG X 100	L7857480001	\$ 10.00
	1X2	Brake B85 DG X 100	<u>L7857490001</u>	\$ 15.00
	1X2	Brake B90 DG X 100	L7857500001	\$ 10.00
	1X2	Brake B100 DG X 100	L7857510001	\$ 10.00
	1X2	Brake B115 DG X 100	L7857520001	\$ 15.00
	1X2	Brake B130 DG X 100	L7883060001	\$ 15.00
	1X2	Brake BC 80	L3512430010	\$ 15.00
	1X2	Brake BC 90	L3512430015	\$ 15.00
	1X2	Brake BC 100	L3512430020	\$ 15.00
	1X2	Brake BC 115	L3512430025	\$ 15.00
	1X2	Brake BC 130	L3512430030	\$ 15.00

DG = Double Grip



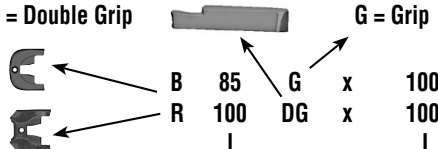
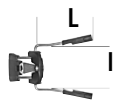



G = Grip

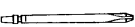
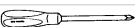

Jigs

			Ref.	\$ Price	
	1X1	Jig STH ²	L3298160001	\$ 100.00	
	1X1	Jig Backcountry (Guardian/Tracker)	L3267050001	\$ 50.00	
	1X1	Jig All Salomon Senior Products & Atomic EVOX and FFG	L0011570001	\$ 75.00	
	1X1	Jig All Salomon Senior Products & Atomic EVOX and FFG	56-99 mm	AZD000066	\$ 75.00
			56-99 mm	L0011560001	\$ 75.00
	1X1	Jig Atomic Evox 045 & Salomon C5		AZD000064	\$ 75.00
				L7840610001	\$ 75.00
	1X1	Jig Z Speed	L1113930001	\$ 50.00	
	1X1	Jig X Bindings	70-116 mm	AZD000084	\$ 120.00
			60-86 mm	L1184730001	\$ 120.00
	1X1	Jig Atomic Neox Bindings	AZD000086	\$ 50.00	
	1X1	Jig SC and SR, + and ++ Adult and Junior	L35678600	\$ 100.00	
	1X1	Jig SC and SR, + and ++ Adult and Junior	L0010030001	\$ 100.00	
	1X1	Jig SC and SR, + and ++ Adult and Junior	AZD000076	\$ 100.00	
	1X1	Jig SC and SR, + and ++ Adult and Junior	L0010400001	\$ 100.00	
	1X1	Jig Easytrak plates	L3086300001	\$ 50.00	

Tools

			Ref.	\$ Price
	1X5	Drill Bit	L0008140001	\$ 50.00
	1X5	Drill Bit	L0008930001	\$ 50.00
	1X5	Drill Bit	L0008130001	\$ 50.00
	1X5	Drill Bit	L0008920001	\$ 50.00
	1X1	Posidrive #3 bit	AZD000046	\$ 18.00
		25 mm long	L0008610001	\$ 18.00
	1X1	Posidrive #3 Screwdriver	L0008620001	\$ 14.00
	1X1	Salomon Adjustment Tool (Flat Blade)	L0009020001	\$ 20.00
	1X100	Repair Plugs	L0008460001	\$ 16.00
	1X1	Mounting Glue	L0008110001	\$ 10.00
	1X100	Plastic Hole Plugs	L0008180001	\$ 3.50
	1X2	Demo Board XTO Neox	AZD000026	\$ 1.00
	1X2	Blank Demoboard for Binding Display (All Retail Bindings except STH2 and Neox)	L0011880001	\$ 1.00
	1X10	Blank Demoboard Short (Fits all Retail including STH2)	L32560100	\$ 10.00

X-Binding Distance Plates

			Ref.	\$ Price
	1X2	Distance Plate Front 2mm X16/X20 09/12	AZD000126	\$ 16.00
	1X2	Base Plate Rear X20 + Screw 60mm 09/12	AZD000118	\$ 8.00
	1X2	Distance Plate Front 3mm X16/X20 09/12	AZD000128	\$ 16.00
	1X2	Distance Plate Rear 1mm X20 09/12	AZD000130	\$ 16.00
	1X2	Distance Plate Front 1mm X16/X20 09/12	AZD000112	\$ 16.00
	1X2	Distance Plate Rear 2mm X20 09/12	AZD000132	\$ 16.00
	1X2	Distance Plate Rear 3mm X20 09/12	AZD000134	\$ 16.00
	1X2	Distance Plate Rear 1mm X16 09/12	AZD000136	\$ 16.00
	1X2	Distance Plate Rear 2mm X16 09/12	AZD000138	\$ 16.00
	1X2	Distance Plate Rear 3mm X16 09/12	AZD000140	\$ 16.00
	1X2	Base Plate Front X16-X12 + Screw 09/12	AZD000170	\$ 16.00

Neox Parts

			Ref.	\$ Price
	1X2	Brake Neox 76 09/12	AZD000104	\$ 15.00
	1X2	Neox Positioning Unit 09/12	AZD000096	\$ 6.00
	1X2	AFD Sil Neox 09/12	AZD000094	\$ 8.00
	1X2	Base Plate Neox TL Toe 09/12	AZD000088	\$ 10.00
	1X2	Base Plate Neox TL Heel 09/12	AZD000090	\$ 10.00
	1X2	Sole length Indicator red NTL 10/12	AZD000092	\$ 10.00

Screws

Reference		mm: Ø x L	\$ Price
	mm: Ø x L		
L0008360001		10 x 20.5	\$ 6.00
L0008990001		10 x 16.5	\$ 6.00
L0010040001		10 x 18.3	\$ 6.00
L0010850001		10 x 36	\$ 6.00
L0010990001		10 x 32.5	\$ 6.00
L0008290001	10 x 13.5		\$ 4.00
L0008940001	10 x 11.8		\$ 4.00
L0008970001	10 x 18.8		\$ 6.00
L0009090001	9 x 10		\$ 4.00
L0009100001	10 x 16.5		\$ 6.00
L0009110001	9 x 18		\$ 6.00

Reference		mm: Ø x L	\$ Price
	mm: Ø x L		
L0009120001	9 x 29		\$ 6.00
L0009300001	9 x 16.5		\$ 5.00
L0009580001	9 x 12.5		\$ 5.00
L0009610001	9 x 8.5		\$ 4.00
L0010570001	9 x 19.5		\$ 6.00
L0010830001	9 x 25.5		\$ 6.00
L7883130001	9 x 17.3		\$ 4.00
L7883250001	9 x 12.2		\$ 8.00
L7883150001	9 x 15.7		\$ 4.00
L3512420001	9 x 31		\$ 6.00

Retail Bindings



	5	4	3
STH [®] 13 & 16	L0008960001	L0008960001	L0008960001
STH 16 steel - STH 16	L0009120001	L0008970001	L0008290001
STH 12 & 14 Driver	L0009120001	L0008970001	L0008290001
STH 12	L0009120001	L0008970001	L0008290001
STH 10	L0010040001		L0008940001
Z 14 - Z 12 - Z 12 Ti	L0010040001		L0008940001
Z 11 - Z 10 - Z 10 Ti	L0010040001		L0008940001
L9 - L 10	L0010040001		L0008940001
L7	L0008990001		L0009090001
T5	L0008990001		L0008960001

	2	1
L0011010001	L0011010001	
000910	L0009110001	
	L0009110001	
L0009110001	L0009300001	
L7883130001	L0009300001	
L7883130001	L0009300001	
L7883130001	L0009300001	
	L0008290001	
	L0008940001	
	L0008940001	
	L0008940001	

Rental Bindings



	5	4	3
STH 16 steel - STH 16	L0010850001	L0010830001	
STH 12 & 14 Driver	L0010850001	L0010830001	
STH 12	L0008360001	L0008940001	
STH 10	L0010850001	L0010830001	
Z 14 - Z 12 - Z 12 Ti	L0010040001	L0009090001	
L9 - L 10	L0010990001		L0009120001
L7	L0008990001		L0008960001

	2	1
	L0009090001	
	L0009090001	
	L0008290001	
	L0009090001	
	L0008940001	
	L0009610001	
	L0008940001	

	A	B
	L0010570001	L0009300001
	L0008940001	L0009580001
	L0008940001	L0009580001
	L0008940001	L0009580001

Plate & System



	5	4	3	2	1
Backcountry		L7883250001		L7883250001	
Z Speed	L3512420001	L7883250001		L0009090001	
Easytrak (Adult - ski group G1 & G2)		L0009110001		L0009110001	
Easytrak (Junior - ski group G3 & G4)		L7883150001		L7883150001	

ALPINE SKIS

Atomic Tips

Ref. \$ Price

	1X2	Race D2 SL (12); Race ST (12); D2 Demo X Type S (12) D2 Demo Type S (12)	S_102 Stainless Steel Neu	AZA000016X	\$ 14.50
	1X2	D2 VF 72 (12); D2 VF 82 (12); D2 VF 75 (12/13); D2 VF 73 (12/13); Women D2 VF 73 (12/13); Cloud 8 (12); D2 Demo VF i (12); D2 Demo VF ii (12); D2 Demo VF Light (12); Performer Carbon (12); Vario Carbon (12/13); Cloud D2 75 (12/13); Cloud D2 73 (12/13); Performer Select (12); Cloud 9 (12); Bluester Demo Elite (12/13); Bluester Demo Fine (12/13)	S_101 Stainless Steel Neu	AZA000014X	\$ 13.00
	1X2	Savage Ti (12); Crimson Ti (12); Blackeye Ti (12); Blackeye (12); Affinity Storm (12)	S_110 4,7	AZA000028X	\$ 10.00
	1X2	Smoke Ti (12); Smoke (12); Whiteout (12); Intruder (12); Codec (12); Colt (12); Affinity Pure (12); Affinity Air (12)	S_110 6,4	AZA000042X	\$ 10.00
	1X2	Race Ti pb SL (12) ; Race SL (12); Performer Pro S (12)	S_112 Stainless Steel	AZA000030X	\$ 14.50
	1X2	Sport Carve (12); MaryLu (12); Drive Select (12); ETL ETI (12/13); ETL (12/13); VR 21 LT LT (12/13); R-Factor SW LT (12/13); R-Factor SC LT (12/13); Vario Scandium ST (12/13); VR 27 ST (12/13); Vario Select SMT (12/13); R-Factor SW ST (12/13); Vario AM Fibre ETI (12/13); Cool Minx ETM (12/13); Seventh Heaven ETM (12/13); VR 07 ETI (12/13); Performer Aero ETI (12/13); Light Elve ETM (12/13); R-Factor CF ETI (12/13)	S_115 Stainless Steel	AZA000034X	\$ 14.50
	1X2	Race D2 SL men (12); Race D2 SL (12); RS D2 SL Men (12); RS D2 SL Women (12); RS SL Men (12); RS SL Women (12); RS D2 SL jr 155 (12); Redster FIS SL Men (12/13); Redster FIS SL Women (12/13)	S_137 Black/Black	AZA000122	\$ 10.00
	1X2	Vario Scandium (12); Cloud 9 (12); Cloud 7 (12); Cloud 6 (12); Balanex (12); Heaven (12) Performer Scandium (12); Performer Fiber (12); Vario Fiber (12/13); GT Vario (12); Vario Pro (12); Cloud Star (12); RC Carve (12); Vario AM Fibre (12); Vario AM Scandium (12); Vario Scandium LT (12/13);	S_123 Stainless Steel	AZA000038X	\$ 10.00
	1X2	Race D2 SL jr. 151 (12); Race SL 12 jr. (12); Redster FIS SL (12/13)	S_125 Black/Black	AZA000124	\$ 10.00
	1X2	Race 10 jr. (12) Race jr. (11/12); Performer Pro jr. (11/12)	S_84 Black / White	AZA000008X	\$ 8.00
	1X2	Elysian jr. (12); Rascal (12); Vantage jr. III ETM (12/13); Vantage jr. III (12/13); Affinity jr. III ETM (12/13); Affinity jr. III Ets (12/13); Rascal II Ets (12/13); Rascal II (12/13); Vantage jr. III Ets (12/13); Vantage jr. II (12/13);	S_40B Black / White	AZA000002X	\$ 15.00
	1X2	ETL (12)	S_51 Black	AZA000000X	\$ 15.00
	1X2	Tune Plus (13), Bluester S FB ARC-L (13), Tune ETL (13), Affinity Shade ARC-L (13), Premium Nomad S Ti ARC (13), Temper Ti ARC (13), Magnet ARC-L (13), Tune Plus ETL (13), Smoke Ti ARC (13), Colt ARC-L (13), Radon Ti ARC (13), Radon ARC (13), Smoke Plus ETL (13), Smoke LT (13), Bluester S FW ARC (13), Blaykeye Ti ARC (13), Blackeye ARC-L (13), Crimson Ti ARC (13), Nomad Demo Tool ARC (13)	S_133 Zamak	AZA000126	\$ 10.00
	1X2	Redster JR III ETM (13), Redster JR II (13), Vantage JR III ETM (13), Vantage Jr II ETS (13), Redster JR III (13), Redster JR III Marcel ETM (13), Vantage Girl III ETM (13), Redster JR Edge ETM (13), Vantage Girl II ETS (13), Redster JR II ETS (13), Redster JR II Marcel ETS (13), Rascal JR II ETS (13)	S_134 Black/White	AZA000130	\$ 10.00
	1X2	VR 27 ST (12/13); VR 17 (12); VR 07 (12/13); Light Elve (12/13); Performer (12/13); Victories (12); VR 21 LT (12/13); VR 21 ST (12); TT 79 (12); TT 72 (12); ETL ETI (12/13); ETL (12/13); R-Factor SW LT (12/13); R-Factor SC LT (12/13); Vario Scandium ST (12/13); Vario Select SMT (12/13); R-Factor SW ST (12/13); Vario AM Fibre ETI (12/13); Cool Minx ETM (12/13), Seventh Heaven ETM (12/13); R-Factor CF ETI (12/13)	S_115 Stainless Steel	AZA000034X	\$ 14.50

Solomon Tips

			Ref.	\$ Price
	1X2	Tip Scrambler Hot, 9, 8, 7, 6, 5, Scrambler Custom, 400, Siam models	L78571000001	\$ 10.00
	1X2	Tip X Wing Blast, Tornado, Sandstorm (2006-2007)	L78799500001	\$ 6.00
	1X2	Tip Instinct, Aeromax, Jewel, Jade Jr M and L, Candy (11) Jr 800 (11)	L24729100001	\$ 8.00
	1X2	Tip X Wing 8, 6, 4, Origin Opal, Topaz, Crystal, Amber, (2009-2010)	L10832800001	\$ 10.00
	1X2	Tip X Wing 8, 6, 4, Origin Opal, Topaz, Crystal, Amber, (2009-2010) with screws	L10832700001	\$ 10.00
	1X2	Tip Replacement and Rental for twintips	L10879900001	\$ 12.00
	1X2	Tip X Wing Focus	L12145600001	\$ 12.00
	1X2	Tip Enduro XT (2011)	L12987800001	\$ 10.00
	1X2	Tip BBR (2011)	L30842400001	\$ 10.00
	1X2	Sunlite (12), Skylite (12), Limelite (12) - BBR 10.0 (12)	L32907500001	\$ 12.00
	1X2	Origins Lava (G12), Origins Bamboo (G12)	L32907600001	\$ 12.00
	1X2	Pure White (11 & 12) - Origins Lime (11) - Origins Sun (11 & 12) - Origins Sun R (11) - Origins Lagoon (11 & 12)	L35151000001	\$ 12.00

ALPINE GOGGLES



To order the correct lens, please refer to the lens code found on the goggles

Examples:

"REM04" matches with lens part ANS105074
 "XTM 13" matches with lens part L35500100



Goggle Lenses

			Ref.	\$ Price		
	1X1	Revel M	Black upgraded Mirror (MS) /Solar	REM01	ANS105084	\$ 30.00
			Blue multilayer (ML) /Solar	REM02	ANS105072	\$ 30.00
			Red multilayer (ML) / Solar	REM04	ANS105074	\$ 30.00
			Yellow multilayer (ML) / Solar	REM14	ANS105076	\$ 30.00
			Black Polar / Solar	REM15	ANS105078	\$ 40.00
			Light-Blue multilayer (ML) / Low light	REM17	ANS105096	\$ 30.00
			Amber-Grey Upgraded Mirror (UM) / Universal	REM18	ANS105092	\$ 30.00
			Amber Standard (S) / Universal	REM20	ANS105082	\$ 15.00
	1X1	Revel S	Blue multilayer (ML) /Solar	RES02	ANS105064	\$ 30.00
			Red multilayer (ML) / Solar	RES04	ANS105066	\$ 30.00
			Light-Blue multilayer (ML) / Low light	RES17	ANS105068	\$ 15.00
			Amber-Grey Upgraded Mirror (UM) / Universal	RES18	ANS105100	\$ 30.00
		Amber Standard (S) / Universal	RES20	ANS105070	\$ 30.00	
	1X1	X-Max Lens	Black upgraded Mirror (MS) /Solar	XXM 01 (Max)	L35485000	\$ 49.00
			Blue multilayer (ML) /Solar	XXM 02 (Max)	L35484900	\$ 25.00
			Black Polar / Solar	XXM 15 (Max)	L35544800	\$ 49.00
			Light-Red multilayer (ML) / Universal	XXM 16 (Max)	L35485300	\$ 49.00
			Light-Blue multilayer (ML) / Low light	XXM 17 (Max)	L35485200	\$ 49.00
			Amber-Grey Upgraded Mirror (UM) / Universal	XXM 18 (Max)	L35485400	\$ 49.00
			Orange Upgraded Mirror (UM) / Low light	XXM 19 (Max)	L35485100	\$ 49.00
			Photochromic Blue multilayer (ML) / All weather	XXM 22 (Max)	L35498700	\$ 49.00
	1X1	X-Tend Lens (Large)	Orange multilayer (ML) / Solar	XTL 03 (Large)	*L35164000	\$ 40.00
			Yellow Mirror (M) / Low Light	XTL 07 (Large)	*L35164400	\$ 25.00
			Yellow Upgraded Mirror (MS) / Low Light	XTL 08 (Large)	*L35164500	\$ 30.00
			Orange Upgraded Mirror (MS) / Universal	XTL 10 (Large)	*L35164700	\$ 30.00
			Orange Mirror (M) / Universal	XTL 11 (Large)	*L35164800	\$ 25.00
			Yellow multilayer (ML) / Solar	XTL 14 (Large)	L35494000	\$ 49.00
			Amber Standard (S) / Universal	XTL 20 (Large)	L35498200	\$ 23.00

	1X1	X-Tend Lens (Small)	Honey Upgraded Mirror (MS) / Solar	XTM 09 (Small)	*L35166100	\$ 30.00
			Orange Mirror (M) / Universal	XTM 11 (Small)	*L35166300	\$ 25.00
	1X1	X-View Lens (Large)	Black upgraded Mirror (MS) /Solar	XVL 01 (Large)	L35495900	\$ 25.00
			Orange multilayer (ML) / Solar	XVL 03 (Large)	L35496100	\$ 25.00
			Orange Mirror (M) / Universal	XVL 11 (Large)	L35498600	\$ 18.00
			Orange Standard (S) / Low Light	XVL 13 (Large)	L35502900	\$ 16.00
			Yellow multilayer (ML) / Solar	XVL 14 (Large)	L35495700	\$ 25.00
			Black Polar / Solar	XVL 15 (Large)	L35503300	\$ 49.00
	1X1	X-View Lens (Small)	Black upgraded Mirror (MS) /Solar	XVS 01 (Small)	L35502700	\$ 25.00
			Blue multilayer (ML) /Solar	XVS 02 (Small)	L35498800	\$ 25.00
			Honey Upgraded Mirror (MS) / Solar	XVS 09 (Small)	L35499100	\$ 25.00
			Orange Mirror (M) / Universal	XVS 11 (Small)	L35502800	\$ 18.00

POLES & HELMETS

Alpine poles

			Ref.	\$ Price
	1X2	Basket for Carbon Poles and Aluminum Poles	L10853700	\$ 6.00
	1X2	Freeski Powder Basket Black	L36325000	\$ 6.00
	1X2	Basket for Aluminum Poles	L10853900	\$ 6.00
	1X2	Basket for Junior Poles	L10854000	\$ 6.00
	1X2	Strap for Rental Adult Poles	L10854200	\$ 5.00

Nordic poles







			Ref.	\$ Price
	1X2	Nordic Power Strap Click	L12708100	\$ 12.00
	1X2	Nordic Power Strap	L12708000	\$ 10.00
	1X2	Nordic Grip Cork Click thumb	L12708200	\$ 8.00
	1X2	Nordic Grip EVA	L12707800	\$ 5.00
	1X2	Nordic Grip EVA Jr	L12707900	\$ 5.00
	1X2	Nordic Racing Basket	L12708300	\$ 10.00
	1X2	Nordic Touring Basket	L12708400	\$ 8.00
	1X2	Racing Basket M : Equipe 100 Carbon - Equipe 60 Carbon - Equipe 20 Carbon - Vitane 20 Carbone - Equipe Carbon Junior (12/13)	L32762300	\$ 10.00
	1X2	Racing Basket S : S-Lab Carbon (12/13)	L32764900	\$ 10.00

ALPINE BOOTS







Atomic Buckle Tooth Insert

			Ref.	\$ Price
	1 Set	RT Toothplate Set 09/12	AZE000262	\$ 10.00
	1 Set	Adj. Toothplate Set 09/12	AZE000268	\$ 10.00
	1 Set	Life Fit Toothplate Set 10/12	AZE000258	\$ 4.00
	1 Set	Waymaker Tour Toothplates	AZE000788	\$ 10.00
	1 Set	Overload Toothplates	AZE000792	\$ 10.00
	1 Set	Waymaker Toothplates	AZE000794	\$ 10.00
	1 Set	Life Fit Adj. Toothplate Set 10/12	AZE000256	\$ 6.00

Atomic Buckles

















			Ref.	\$ Price
	1X2	Tracker Women Buckle P1	AZE000850	\$ 10.00
	1X2	Tracker Women Buckle P2	AZE000836	\$ 16.00
	1X2	Tracker Women Buckle P3+4	AZE000838	\$ 16.00
	1X2	Carabiner Buckle Set silver P1	AZE000652	\$ 27.50
	1X2	Carabiner Buckle Set silver P2	AZE000668	\$ 27.50
	1X2	Carabiner Buckle Set silver P3+4	AZE000654	\$ 27.50
	1X2	Redster Buckle P1	AZE000798	\$ 15.00
	1X2	Redster Buckle P2	AZE000834	\$ 15.00
	1X2	Redster Buckle P3+4	AZE000800	\$ 15.00
	1X2	Waymaker Tour Buckle P1	AZE000814	\$ 10.00
	1X2	Waymaker Tour Buckle P2+3	AZE000848	\$ 10.00
	1X2	Waymaker Buckle P1	AZE000808	\$ 10.00
	1X2	Waymaker Buckle P2+3	AZE000828	\$ 15.00
	1X2	Waymaker Carbon Buckle P1	AZE000810	\$ 12.00
	1X2	Waymaker Carbon Buckle P2+3	AZE000846	\$ 10.00
	1X2	Overload Buckle P1	AZE000844	\$ 20.00
	1X2	Overload Buckle P2	AZE000824	\$ 18.00

Atomic Innerboot







			Ref.	\$ Price
	1X2	Tracker ASY Elite Liner	24.5 / 25.5 / 26.5 / 27.5 / 28.5 / 29.5	AZE000852 \$ 70.00
	1X2	Tracker Woman ASY Pro Liner	22.5 / 23.5 / 24.5 / 25.5 / 26.5 / 27.5	AZE000860 \$ 60.00
	1X2	Redster World Cup Liner	22.5 / 23.5 / 24.5 / 25.5 / 26.5 / 27.5 / 28.5 / 29.5	AZE000854 \$ 80.00
	1X2	Live Fit ASY Pro	25.5 / 26.5 / 27.5 / 28.5 / 29.5 / 30.5 / 32.5	AZE000888 \$ 60.00
	1X2	Hawx ASY Elite Liner	28.5 / 29.5 / 30.5 / 31.5	AZE000864 \$ 65.00
	1X2	Hawx Woman ASY Pro Liner	22.5 / 23.5 / 24.5 / 25.5 / 26.5 / 27.5	AZE000868 \$ 65.00
	1X2	Overload ASY Pro	24.5 / 25.5 / 26.5 / 27.5 / 28.5 / 29.5	AZE000886 \$ 60.00

Atomic Bootfitting

			Ref.	\$ Price
	1X2	Redster Medium Frame white	22.0 / 23.0 / 24.0 / 25.0 / 26.0 / 27.0 / 28.0 / 29.0	AZE000744 \$ 10.00
	1X2	Redster No Frame Boot Board	22.5 / 23.5 / 24.5 / 25.5 / 26.5 / 27.5	AZE000632 \$ 7.00
	1X2	Redster Boot Board High	22.5 / 23.5 / 24.5 / 25.5 / 26.5 / 27.5 / 28.5 / 29.5	AZE000628 \$ 7.00
	1X2	Redster Boot Board Low	22.5 / 23.5 / 24.5 / 25.5 / 26.5 / 27.5 / 28.5 / 29.5	AZE000638 \$ 7.00
	1X2	Redster Flex Frame Kit	22.5 / 23.5 / 24.5 / 25.5 / 26.5 / 27.5 / 28.5 / 29.5	AZE000630 \$ 20.00
	1X2	Insole soft red 10/12	24.0 / 25.0 / 26.0 / 27.0 / 28.0 / 29.0	AZE000284 \$ 8.00
	1X2	4mm Heel Wedge Waymaker	22.0 / 23.0 / 24.0 / 25.0 / 26.0 / 27.0 / 28.0 / 29.0 / 30.0 / 31.0	AZE000936 \$ 3.00

	1X2	2mm Volume Shim Waymaker/LF	22.0 / 23.0 / 24.0 / 25.0 / 26.0 / 27.0 / 28.0 / 29.0 / 30.0 / 31.0 / 32.0	AZE000934	\$ 3.00
	1X2	Waymaker/Overload Boot Board	22.5 / 23.5 / 24.5 / 25.5 / 26.5 / 27.5 / 28.5 / 29.5 / 30.5 / 31.5	AZE000916	\$ 7.50
	1X2	WaymakerTour/Carbon Boot Board	22.5 / 23.5 / 24.5 / 25.5 / 26.5 / 27.5 / 28.5 / 29.5	AZE000898	\$ 7.00
	1 Set	X Center Canting Set 09/12		AZE000334	\$ 10.00
	1 Set	Micro Cuff alignment Set		AZE000672	\$ 10.00
	1 Set	Rotational Power Control Set		AZE000676	\$ 5.00
	1X2	Rotational Cuff Hardware 0mm		AE5007980	\$ 5.00
	1X2	Rotational Cuff Hardware 3mm		AE5008000	\$ 5.00
	1X2	Rotational Cuff Hardware 5mm		AE5008020	\$ 5.00
	1 Set	Redster Strapholder Set		AZE000704	\$ 4.00
	1X2	Tracker Dual Strap		AZE000918	\$ 25.00
	1X2	Hawx Live Fit Strap 45mm		AZE000920	\$ 11.00
	1X2	Hawx Live Fit Strap 35mm Woman		AZE000902	\$ 10.00
	1X2	Tracker/Waymaker Carb W 35mm		AZE000900	\$ 10.00
	1X2	Redster 35mm Strap		AZE000922	\$ 10.00
	1X2	Redster Dualstrap long		AZE000924	\$ 22.00
	1X2	Redster Dualstrap short		AZE000904	\$ 22.00
	1X2	Waymaker Carb/Overload 50mm		AZE000906	\$ 13.00
	1X2	Waymaker 35mm Strap		AZE000910	\$ 10.00
	1X2	Waymaker Tour 35mm Strap		AZE000912	\$ 10.00
	1X2	Strap 45mm (MT,Hawx,LF,BT)		AZE000724	\$ 12.00
	1X2	Strap 35mm W (Hawx,LF,MT,BT)		AZE000742	\$ 8.00

Atomic Bootsole + Screws

				Ref.	\$ Price
	1X2	Skywalk Gripplates black		AZE000728	\$ 12.00
	1X2	Skywalk Gripplates 22.0-23.5		AZE000786	\$ 12.00
	1X2	Hawx, MT, LF Gripplate Set bla S 10/12		AZE000254	\$ 8.00
	1X2	Hawx, MT Gripplate Set bla L 10/12		AZE000252	\$ 8.00
	1X2	Grippads jr. bla (18.5-21.5) 09/12		AZE000270	\$ 5.00
	1X2	Grippads jr. bla (22.0-26.5) 09/12		AZE000272	\$ 5.00
	1X2	Redster Lifter 3mm 22.5-25.5		AE5007920	\$ 15.00
	1X2	Redster Lifter 3mm 26.5-29.5		AE5007900	\$ 15.00
	1X2	Redster Lifter 5mm 22.5-25.5		AE5007940	\$ 15.00
	1X2	Redster Lifter 5mm 26.5-29.5		AE5007960	\$ 15.00
	1X2	HAWX 2 CO Gripplates S		AE5008040	\$ 8.00
	1X2	HAWX 2 CO Gripplates L		AE5008060	\$ 8.00
	1X2	MNC DIN Grip Pad Small SOLID BLACK/SOLI		AZE000768	\$ 10.00
	1X2	MNC DIN Grip Pad Large SOLID BLACK/SOLI		AZE000774	\$ 10.00
	1X2	MNC Touring Grip Pad Small SOLID BLACK		AZE000772	\$ 35.00
	1X2	MNC Touring Grip Pad Large SOLID BLACK		AZE000770	\$ 35.00

Salomon Buckle Tooth Inserts

			Ref.	\$ Price
	1X2	Buckle Tooth Insert: X Wave, Rush, Falcon, Instinct, Impact Idol, X Max, X6, Quest, Quest Max, Junior	Shell	L30852100 \$ 3.00
	1X2	Buckle Tooth Insert: 1/4 Turn adjustable Rental: Performa, Irony, X Wave, Rush, Impact, Idol	Cuff	L12006900 \$ 5.00
	1X2	Buckle Tooth Insert: Focus, Quest, SPK, Ghost, Shogun, Poison, Quest Access, Quest Max, Ghost Max	Cuff	L30852200 \$ 5.00

Salomon Buckles (M* = Micro / V* = Vario)

			Ref.	\$ Price
	M*	Alu Buckle: X Pro	S	L36642600 \$ 15.00
	1X2		L	L36642700 \$ 15.00
	M*	Alu Buckle: Ghost, SPK, Shogun (13)	S	L36642800 \$ 20.00
	1X2		L	L36642900 \$ 20.00
	M*	Alu Buckle: Ghost, Shogun, Poison, Pro Model, Kaos, Kreation, Kaid SPK	S	<u>L10818000</u> \$ 20.00
	1X2		L	<u>L10818100</u> \$ 20.00
	M* 1X2	Alu Buckles Quest Access (Upper)	L	L30852800 \$ 12.00
	M*	Alu buckles X Max - X6 (13)	S	L36643100 \$ 15.00
	1X2		L	L36643200 \$ 15.00
	M*	Alu buckles X Max - X6	S	L35174700 \$ 15.00
	1X2		L	L35174800 \$ 15.00
	M*	Alu buckles Quest Max - X6	S	L35174900 \$ 15.00
	1X2		L	L35175000 \$ 15.00
	M*	Plastic Buckles Mission/Divine, Mission RS, Charm, Performa, Elios, Irony (Black)	S	L12007400 \$ 8.00
	1X2		M	L12007500 \$ 8.00
			L	L12007600 \$ 8.00
	V*	Buckle Symbio	S	L78396900 \$ 7.00
	1x1		L	L78397000 \$ 7.00
	V* 1X2	Symbio Upper Cuff Buckle	22.0-25.5 540mm	L88284400 \$ 12.00
			26.0-30.0 560mm	L88284500 \$ 12.00
			22.0-25.5 580mm	L78862700 \$ 12.00

Innerboot

			Ref.	\$ Price
	1X2	X Max (My Customfit Race)	24.5 / 25.5 / 26.5 / 27.5 / 28.5 / 29.5	L35175200 \$ 85.00
	1X2	Quest Max (My Customfit Race)	24.5 / 25.5 / 26.5 / 27.5 / 28.5 / 29.5	L35175300 \$ 85.00
	1X2	X Pro My Customfit Perf	24.5 / 25.5 / 26.5 / 27.5 / 28.5 / 29.5 / 30.0	L36642300 \$ 85.00
	1X2	Quest Max BC	24.5 / 25.5 / 26.5 / 27.5 / 28.5 / 29.5	L36642100 \$ 85.00
	1X2	Quest	24.5 / 25.5 / 26.5 / 27.5 / 28.5 / 29.5 / 30.5 / 31.5	L35175400 \$ 80.00
	1X2	SPK - Kaos	22 / 23.5 / 24.5 / 25.5 / 26.5 / 27.5 / 28.5	L35291000 \$ 80.00
	1X2	Quest Rental - Quest Access	24.5 W / 25.5 W / 26.5 / 27.5 / 28.5 / 29.5	L12001800 \$ 45.00
	1X2	Symbio	22 / 23.5 / 24.5 / 25.5 / 26.5 / 27.5 / 28.5 / 29.5 / 30.5	L36704200 \$ 50.00

Salomon Service Parts

			Ref.	\$ Price
	1X1	Custom Fit Liner Heat Machine	L35689700	\$ 295.00
	1X2	Cool pack for Custom Shell process	22 - 26 L35117700	\$ 50.00
			27 - 31 L35117800	\$ 50.00

Salomon Bootfitting









			Ref.	\$ Price
	1X2	Rental Insoles	18 / 19 / 20 / 21 / 22 / 23-23.5 / 24-24.5 / 25-25.5 / 26-26.5 / 27-27.5 / 28-28.5 / 29-29.5 / 30-30.5 / 31-31.5 / 32-32.5 / 33-33.5 L10078600	\$ 5.50
	1X2	X Wave - Rush Boot Boards	24-24.5 / 25-25.5 / 26-26.5 / 27-27.5 / 28-28.5 / 29-29.5 L88164000	\$ 8.00
	1X2	X Max - Semelle interne de coque - Internal shell insole	24.5 / 25.5 / 26.5 / 27.5 / 28.5 / 29.5 L35177800	\$ 4.00
	1X2	Innerboot Sole X-Pro/Quest Max	24.0-25.5 / 26.0-27.5 / 28.0-29.5 / 30.0-31.5 L36643500	\$ 6.00
	1X4	Toe Dam Rubber Seals Impact, Idol, Falcon, Instinct, Mission RS, Divine RS	22-25.5 L55472300	\$ 8.00
			26-31.5 L55473000	\$ 8.00
	1X4	Toe Dam Rubber Seals X Max 22-31.5	22-31.5 L36643600	\$ 8.00
	1X2	Alpine Boots Strap 35mm	22-25.5 L36643800	\$ 12.00
			26-33.5 L36643900	\$ 12.00
	1X2	Sangle bas de jambe - Strap	W 45mm L35175600	\$ 12.00
			M 55mm L35175700	\$ 12.00

Innerboot Adaptation / Bootfitting

			Ref.	\$ Price
	1X2	4mm Heel Height Adjustment Wedge	L48997000	\$ 4.00
	1X4	Rivet Canting Kit: Falcon, X Wave, Impact, Idol, Quest, Mission RS, Divine RS	L78399000	\$ 8.00
	1X2	Oversized pivot : X Max - Quest Max	L35175800	\$ 13.00
	1X4	Racing T Nuts for Upper Cuff: X2- X3	L78399100	\$ 6.00
	1X2	Forward Lean Adjustment Wedge (All Course Products)	22-25.5 L88239700	\$ 7.00
			26-30 L88239800	\$ 7.00
	1X8	Alpine Boot Self Tapping Screw Kit	L36674300	\$ 3.00
	1X2	Walk Soles Plus (WTR + Tech Inserts)	L35521500	\$ 45.00
	1X2	Walk soles (WTR)	L32749900	\$ 25.00
	1X2	Cantable DIN Pads Black (Grindable to 1.5 degrees)	L36225400	\$ 20.00

Salomon Bootsole and Screws

			Ref.	\$ Price
	1X2	Rear Boot Sole for Performa, Evolution, Symbio 440 (2005 and newer), Elios, Charm 8mm	22-33.5 L48745000	\$ 6.00
	1X2	Front Boot Sole for Evolution, Performa T3, Symbio, Evolution, Verse, Ellipse 8mm	22-25.5 L48961700	\$ 6.00
			26-33.5 L48961800	\$ 6.00
	1X2	Rear Boot Sole Walkadin for Impact, Idol, Mission, Divine, SPK, Performa and Irony	22-33.5 L55437200	\$ 8.00
	1X2	Front Pad 12mm	22-25.5 L53527600	\$ 8.00
	1X2	Front Pad 12mm	26-33-5 L53527700	\$ 8.00
	1X2	Rear Boot Sole for Quest, Mission RS, Divine RS	all L10079000	\$ 8.00
	1X2	Embout Alpin Avant - Vorne - Punta - Toe - Front - Puntera - Quest Max / Quest / Quest Access	L35175900	\$ 5.00
	1X2	T1 - Toe - Front - Puntera	L35238300	\$ 4.00
	1X2	T1 - Back - Posterior	L35238400	\$ 4.00

	1X2	Lifters LAB 3 & 5mm - X Lab - X Max 130		L33003300	\$ 10.00
	1X2	Lifters RACE 4mm - X Max 120 - X Max 110		L33003400	\$ 10.00
	1X10	Lifters CANTING - X Max 120 - X Max 110		L33003500	\$ 35.00
	1X2	Boot Sole REAR for Rush, Falcon, X Wave, Course GT, Course T, Course 100-90-80-70		L88164200	\$ 5.00
	1X2	Boot Sole Rear for Team 3.0, Team 3.5		L48976300	\$ 5.00
	1X2	Boot Sole Rear for 12 Mini, 15 Mini	16-17	L48803000	\$ 3.00
	1X2	Boot Sole Front for Falcon 60, Impact 60, Performa T2, Performa T4 Small, Course 60 (18-21)		L88238100	\$ 6.00
	1X2	Boot Sole Rear for Falcon 60, Impact 60, Performa T2, Performa T4 Small, Course 60 (18-21)		L88238200	\$ 6.00

NORDIC SKI

Laces

Ref. \$ Price

	1X10	Cable eyelet Quickfit - Passant Cable Quickfit		L10108000	\$ 4.00
	1X2	Zip Black		L10108100	\$ 10.00
	5X2	Puller / cap kit		L35163400	\$ 20.00
	1X2	Velcro Strap		L25823700	\$ 6.00

Rivet

Ref. \$ Price

	1X5	Rivet Carbon Pro, Racing Skate 9, Active 9 Skate, Vitane 9 Skate		L10106800	\$ 4.00
	1X5	Rivet 861, Active 8 Skate CL, Vitane 8 Skate CL, Equipe Combi		L10109200	\$ 4.00
	1X5	Rivet- Nail Active 08 black		L12011800	\$ 4.00



Energizer

Ref. \$ Price

		Carbon Energizer T1		L102906001	\$ 50.00
		Carbon Energizer T2		L102907001	\$ 50.00
		Carbon Energizer T3		L102908001	\$ 50.00







Plugs and Cap

Ref. \$ Price







	1X10	Plugs 10 pack - Black		L8900940001	\$ 4.00
	1X10	Capot Profil Equipe Classic, Profil Equipe Skate, Profil Active SC (10 pack)		L1010210001	\$ 6.00
	1X1	Capot w/screw Pilot Sport		L5545430001	\$ 3.00

Flexor

Ref. \$ Price

	1X2	Flexor 1X2 Profil Equipe Skate	115: (red)	L1010420001	\$ 5.00
	1X2	Flexor 1X2 Profil Equipe Skate	125: (red)	L1010430001	\$ 5.00
	1X2	Flexor 1X2 Profil Equipe Classic	85: (yellow)	L1010220001	\$ 5.00
	1X2	Flexor 1X2 Profil Active SC	105: (grey)	L1010510001	\$ 5.00
	1X2	Flexor 1X2 Profil Auto Men	105: (black)	L1010480001	\$ 5.00
	1X2	Flexor 1X2 Profil Auto Women	95: (grey)	L1010490001	\$ 5.00
	1X2	Flexor 1X2 Profil Auto Junior	Junior: (yellow)	L1010500001	\$ 5.00
	1X2	Flexor 1X2 SNS X Adventure Raid	185: (grey)	L1010440001	\$ 5.00
	1X2	Flexor 1X2 SNS propulse RC, SNS propulse RC2	85: (yellow)	L1203500001	\$ 5.00
			95: (grey)	L1201170001	\$ 5.00
	1X2	SNS propulse RC, SNS propulse RC 2 RS10	85: (red)	L3086330001	\$ 5.00
	1X2	Flexor Profil/Pilot		L3627730001	\$ 5.00

Ridge Plate

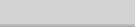
			Ref.	\$ Price
	1X2	Ridge Plate Pilot Skate	L7884690001	\$ 10.00
	1X2	Ridge Plate Profil Equipe	L7884720001	\$ 10.00
	1X2	Ridge Plate Profil Auto Universal	L7884710001	\$ 10.00
	1X2	S/E Plate EQCL Pilot	L5545400001	\$ 18.00
	1X2	SPS Plate and screw	L2582350001	\$ 5.00
	1X2	Ridge Plate RC	L3518470001	\$ 5.00
	1X2	1X2 Ridge Plate RC2	L3518480001	\$ 5.00

Steel Link

			Ref.	\$ Price
	1X2	Steel Link Pilot + axe (pair)	L7884730001	\$ 8.00













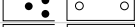
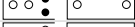

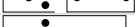
Lever

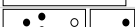
			Ref.	\$ Price
	1X2	Profil Auto Lever	L3518460001	\$ 4.00

Service Products

			Ref.	\$ Price
	1X1	Mounting Jig Profil, Pilot, BC, X-Adventure	L8910000001	\$ 65.00
	1X4	Reversible Jig pads	L1010640001	\$ 15.00
	1X5	Drill Bit junior Ø 3.6 X 8 mm	L0008140001	\$ 50.00
	1X1	Drill Bit Ø 3.6 X 15 mm	L1010520001	\$ 50.00
	1X100	Repair Plugs	L0008460001	\$ 16.00
	1X10	Sticker Pilot	L5545390001	\$ 5.00
	1X10	Sticker Propulse	L3086340001	\$ 5.00
	1X10	Rubber sticker Propulse	L3519180001	\$ 5.00

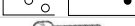
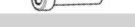



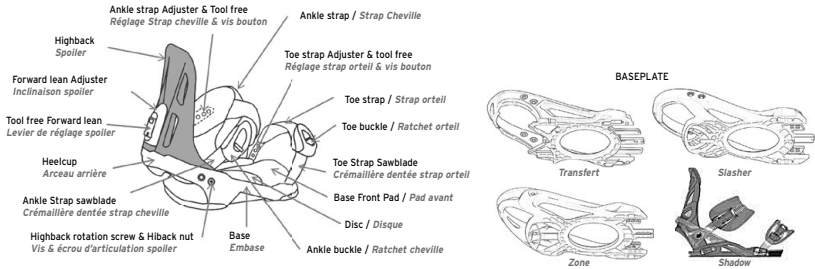

Screws

			Ref.	\$ Price
	1x100	Profil Equipe Junior Ø 6,3 x 14,5	L7885990001	\$ 19.00
	1x100	Profil Equipe Skate - Profil Equipe Classic - Profil Active SC Ø 6,3 x 17,7	L8901110001	\$ 14.00
	1x100	SNS propulse RC, SNS propulse RC 2 Ø 6,3 x 26	LF872020001	\$ 14.00
	1x100	SNS X Adventure Raid		
	1x100	SNS X Adventure Raid		
	1x100	Pilot Equipe Skate - SNS X Adv Access - Profil Auto Men/ Women		
	1x100	Pilot Sport Skate/Classic/ Women		
	1x100	Plaque SPS Pilot Sport Skate/Classic/Women Ø 6,3 x 19,5	L8901090001	\$ 13.00
	1x100	Pilot Equipe Classic		
	1x100	Profil Equipe Skate - Profil Equipe Classic - Profil Active SC		
	1x100	SNS propulse RC, SNS propulse RC 2		
	1x100	Profil Auto junior		
	1x100	Pilot Equipe Classic Ø 6,3 x 14,5	L8901120001	\$ 13.00
	1x100	Profil Snow/Monster		
	1x100	Pilot Sport Junior - Pilot Junior		
	1x100	Profil Equipe Junior Ø 6,3 x 14,5	L8901120001	\$ 13.00
	1x10	Equipe Classic Pilot	L5545410001	\$ 3.00

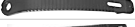

SNOWBOARD BINDINGS

NB: Pas de pièces détachées pour les fixations S PRO TEAM No spare parts for S PRO TEAM bindings

		Ref.	\$ Price
Transmission Pads			
	Base Pad Relay	Black: S / M / L	L53527200 \$ 10.00
4x4 Disks			
	1X8 Screw and washers for disk for all models except Rental		L88999300 \$ 2.50
	Universal Disc & IMS + Screws + Washers All Models except rental models		L35148300 \$ 10.00
Straps			
	Toe Strap + M4 Toolfree Black	S: (white) / M: (white) / L: (white)	L12023600 \$ 10.00
	Toe Strap Zone + M4 Toolfree for toe adjuster with holes Black	White S / White M/L	L30847000 \$ 6.00
	Toe Adjuster All Model>2012 and all Zone Model Except SP	Black S / Black M/L	L78563500 \$ 2.00
	Holding Toe Strap Adjuster All Relay and Slasher Models	White	L78839300 \$ 3.00
	Holding Toe Strap Adjuster All Force and Grace Models	Black	L53527500 \$ 3.00
	Toe Sawblade for all SP models from 06 on	Black S/M / Black L	L78837000 \$ 4.00
	Narrow Toe Sawblade 19mm and Holding fast fit pin for all models with narrow buckle from 2010 on	Black S/M / Black L	L12023800 \$ 2.00
	1X2 Toe Sawblade without Fast fit + pin for all model without Fast fit	Black	L30847200 \$ 2.50
	1X2 Toe Ratchet Viper for sawblade 19mm width and screw pz2 (pair) all models 2010 and newer		L12024100 \$ 7.00
	1X2 Ankle Buckle Viper and screw pz2 (pair) Ankle All Models, and toe through 2010		L12024300 \$ 7.00
	1X2 L+R Standard Ankle Strap (for all Relay models through 2011) 165mm	(black) 165 mm / S	L78560000 \$ 15.00
		(black) 185 mm / M/L	L78560000 \$ 15.00
	1X2 L+R Cored Out Ankle Strap for ladder Strap with holes	Black S/M	L12024400 \$ 15.00
		Black L	L12024400 \$ 15.00
	1X4 Ankle Strap Kit (Screw M5 + Nut M5) Ankle All Force and Grace Models		L78836800 \$ 5.00
Highback			
	Highback Rotation Kit (All Slasher, SPX, and Transfert models)		L89380200 \$ 4.00
	1X2 Toolfree FWL Adjuster (All Models except Shadow)		L78837500 \$ 7.00
Rental / Speedfit / Fastec			
	Disc for Speedfit and Fastec models		L78333800 \$ 25.00
	Screw 4X4 M6 X 20 (8 pack)		L78620500 \$ 4.00
Rental / Speedfit			
	1X2 Rental Plastic Buckle + screw M5 + save nut M5 X 9		L78619000 \$ 8.00
	1X2 Rental Tool Free Ankle Strap Adjustment: quick cricket		L78619100 \$ 5.00
	1X2 Rental Sawblade Fast Fit Toe Straps hole 9.5mm (through 2011)		L78619200 \$ 4.00

	1X2	Rental Sawblade Ankle Straps hole 9.5mm for bolt guard (from 05), Sawblade Ankle and Toe (through 11)		L78619300	\$ 4.00
	1X2	Holding Fastfit: Toe Strap snap support easy base		L78619400	\$ 2.00
	1X2	Toestrap L/XL or S/M (through 2011)		<u>L78619500</u>	\$ 10.00
	1X2	Heelcup Lever		L78620600	\$ 2.00
	1X4	Highback Screw + washer + nut M6		L78620700	\$ 5.00
	1X2	Forward Lean Kit Adjuster HB + Screw & nut M5 X10 (Through 2010)	S/M	<u>L78621300</u>	\$ 5.00
	1X2	Forward Lean Kit Adjuster HB + Screw & nut M5 X10 (Through 2010)	L/XL	<u>L78621400</u>	\$ 5.00
	1X2 L&R	Scratches + Springs + Covers + Levers + Screws		L78840000	\$ 15.00
Rental / PIQ / PIQ Kid				Ref.	\$ Price
		Ankle and Toe Buckle for Sawblade 23.5mm + screw PZ2 for all models Ankle and Toe PIQ (1X2)		L12024300	\$ 7.00
Metalic 4x4 Disks				Ref.	\$ Price
	1X2	PIQ Rental Disk + Screws All Models PIQ , PIQ Kid		L35149700	\$ 40.00
	1X20	PIQ mounting Screws M6x22 for PIQ Rental disk All Models PIQ , PIQ Kid		L35149400	\$ 5.00
Kit of Adjustable Toe Cap Strap for Sawblade 19 mm				Ref.	\$ Price
	1X2	Toe Strap Zone + M4 Toolfree for toe adjuster with holes Black	White S / White M/L	<u>L30847000</u>	\$ 6.00

SNOWBOARD BOOTS

Laces			Ref.	\$ Price	
	1X2	Power Lace Handle (through 2011)	<u>L78396100</u>	\$ 4.00	
	1X2	SPL Lace Pulley 1*2	<u>L10836200</u>	\$ 2.00	
	1X2	Lace (white) All sizes	L12039000	\$ 2.00	
	1X2	New Combo ("tongue lace locker with springs")	<u>L99494700</u>	\$ 2.00	
	1X2	Lace Cable	130 cm / 22.0-26.5 140 cm / 27.0-31.5	L19578800 L12039300	\$ 5.00 \$ 5.00
	1X2	SPL 4 Locker	L30861500	\$ 2.00	
	1X25m	C4D-1 WRN 2.0MM	L30861400	\$ 20.00	
	1X2	Lace Handle and Lace	L30860400	\$ 5.00	

FOOTWEAR

Laces			Ref.	\$ Price
		Quick Lace Small Kit White	<u>L12012400</u>	\$ 6.00

Retail Binding Limited Warranty

Atomic and Salomon Retail Alpine Bindings are covered under warranty against defects in materials and manufacturing for a period of five years from their date of purchase to the original customer. In the absence of proof-of-purchase, this warranty period will be five years from date of manufacture of the product as indicated by production code. This warranty only covers the defective component, not the full pair or set, i.e., left toe piece, brake, right heel, etc. Abuse and normal wear are not covered by this warranty.

Replacement Procedures

Step One: Verify by customer receipt or production code that the defective component is under warranty. (Warranty claims should be handled through Authorized Dealers to ensure speed and accuracy of product replacement. Please do not refer a customer directly to Atomic or Salomon.)

Step Two: Call customer service for return authorization number.

Step Three: Return the defective set to Atomic or Salomon with the return authorization number clearly printed on the outside of the package. Return the entire set, unless otherwise instructed by customer service.

Ship the package freight pre-paid to:

USA
ASWO Service Center
Building 5X, Bay 6
710 West Amidan Drive
Ogden, UT 84404

Canada
Amer Sports Canada Inc.
85 Davy Road
Belleville (Ontario) K8N 5B6

Upon a dealer's request to Customer Service, a warranty replacement component can be shipped in advance to the dealer before it is inspected at the Service Center. Amer will invoice the dealer for the replacement component and issue a credit when the defective component is received and verified. If the defective component exchanged for the advance replacement is not received within 45 days from the issue of the Return Authorization Number, or proves not to be defective, no credit will be issued for the replacement product.

Step Four: Atomic or Salomon will ship the replacement product to the dealer, surface freight pre-paid, after verification of the defect.

Atomic & Salomon Service Center

In the event an unusual situation is encountered or a technical question arises please call the Service Center at:

USA 1-800-654-2668

CAN 1-800-361-3398 ext. 4113

Wintersports Equipment Warranty Policy

Atomic and Salomon distribute products through a worldwide network of authorized distributors and retailers and on the on-line stores.

You will find herein/below all Atomic and Salomon warranty policy details offered by Atomic and Salomon and their authorized retailers.

I. Warranty definition

This warranty policy is valid as of November 1st 2010.

Atomic and Salomon provide this warranty to purchasers of their products. Atomic and Salomon products are guaranteed against all manufacturing or material defects (Defect) for the Warranty Period as defined below.

Atomic and Salomon products are compliant with their description and specifications; it is your responsibility to ensure that the products you purchase are compatible for the intended use.

This warranty is valid and enforceable only in the country where the Product was purchased by the end user, provided that Atomic or Salomon has intended the Product for sale in that country.

Please refer to the Atomic or Salomon authorized retailers list, available on the website.

Depending on the country, particular and variable warranties may apply in relation to applicable legislation. Nothing in this warranty policy can exclude or limit these statutory provisions.

Warranty Period

The Warranty Period starts at the date of retail purchase of the Product by the original end-user purchaser. The product may consist of several different parts and different parts

may be covered by different warranties periods (please report to "Warranty Period").

The different Warranties Periods are :

- Three (3) years for winter sports pants and jackets
- Select* snowboard binding baseplates and highbacks have a limited lifetime warranty.
- Two (2) years for other products

To the extent permitted by national laws, the Warranty Period will not be extended, renewed or otherwise affected due to subsequent resale, repair or replacement of the Product.

However, part(s) repaired or replacement product(s) during the Warranty Period will be warranted for the remainder of the original Warranty Period provided replacement or repair has been performed by Atomic, Salomon, or an authorized Atomic or Salomon retailer.

Depending on the country, particular and variable Warranties Periods may apply in relation to applicable legislation.

Nothing in this warranty policy can exclude or limit these statutory provisions.

II : The warranty does not cover:

- Damages due to transportation
- Damages due to storage
- Damages due to improper use of the products and poor maintenance
- Damages due to non-observance of the instructions or restrictions for use of the products as defined in the products owner manual
- Damages due to the products normal wear and tear
- Damages due to non-observance of the instructions for maintenance as defined in the products owner manual

Mechanical Inspection Failures

Normal wear is expected with the use of a product. Should a component fail a mechanical inspection (measured release values that fall outside the "In-Use Range") within its warranty period, include the following information with the returned component.

- Description of inspection that the component failed.
- Brand of test device and date of most recent calibration.
- Skier Code and visual indicator setting.
- Boot brand, model and sole length.
- All measured release values and name of the technician.

Every Atomic and Salomon binding component is precision tested to assure its accuracy during manufacture. It is extremely rare that a component would be out of calibration unless there is visible damage. All bindings returned due to mechanical testing failures are inspected. No replacement product will be issued unless all required information is included with the product.

Product Age Verification

Verification that the product is within the warranty period can be made in the following two ways:

1. Customer receipt indicating product was purchased within the last five years.
2. Component production code* indicating manufacture of product within last five years.

NOTE

* All Atomic and Salomon binding components are stamped with a two- or three-digit code upon their final production to indicate month and year of production. Normally, codes are a letter followed by a number, with the letter indicating month of production. Each number corresponds to the actual year of production, i.e., '9' would indicate 2009, '0' would indicate 2010, etc. To simplify the warranty process, product age is determined by the year of production only. Retail bindings with a production code indicating that the bindings were manufactured in 2009 (e.g., A9, M9) will be warranted until the end of the 2013/2014 ski season. Production codes are stamped in various places on all binding components.

- Damages due to modification of the products
- Damages due to any impact caused by sharp items, due to torsion, compression, a fall, an abnormal impact or other actions that cannot be under Atomic or Salomon's reasonable control.

The present warranty is not enforceable if :

1. The Product is not returned in its original packaging, if it has been modified or repaired by any person or entity other than Atomic, Salomon, or an authorized Atomic or Salomon retailer;
2. The Product has been repaired with unauthorized spare parts;
3. The Product serial number has been removed, deleted, altered or made illegible.

III : Warranty enforcement

In case of Defect, Atomic or Salomon agrees to accept the claim, replace, repair or credit the product at no charge for the end-user and return it. This shall be determined in the sole discretion of Atomic or Salomon or the authorized retailer, unless this is impossible or disproportionate.

The remedy will be deemed to be disproportionate if Atomic or Salomon if it imposes costs on Atomic or Salomon which, in comparison with the alternative remedy, are unreasonable, taking into account :

- The value the goods would have if there were no Defect,
- The significance of the Defect,
- Whether the alternative remedy could be completed without significant inconvenience to the consumer.

Atomic and Salomon agree that all repair or replacement of the product will occur within a reasonable period and without any major in-

convenience for the consumer, taking account of the good's kind and its fitness for purpose.

The consumer is not entitled to have the contract rescinded if the Defect is minor.

For all warranty claims, please produce the product and the proof of purchase to the nearest authorized Atomic or Salomon retailer or in case you purchased the product from an online store, please contact the Atomic & Salomon Service Center.

Limitation of Liability

TO THE EXTENT PERMITTED BY NATIONAL LAWS, THE PRESENT WARRANTY IS EXCLUSIVE AND IN LIEU OF ALL OTHER WARRANTIES. NEITHER ATOMIC NOR SALOMON SHALL BE HELD LIABLE FOR ANY CONSEQUENTIAL DAMAGES INCLUDING BUT NOT LIMITED TO LOSS OF CHANGE OR PROFITS, LOSS OF SAVINGS OR REVENUE, LOSS OF DATA, PUNITIVE DAMAGES, LOSS OF USE OF THE PRODUCT OR ANY ASSOCIATED FACILITIES, COST OF CAPITAL, COST OF ANY SUBSTITUTE EQUIPMENT OR FACILITIES, DOWNTIME, THE CLAIMS OF ANY THIRD PARTIES, INCLUDING CUSTOMERS, AND INJURY TO PROPERTY, RESULTING FROM THE PURCHASE OR USE OF THE PRODUCT OR ARISING FROM BREACH OF THE WARRANTY, BREACH OF CONTRACT, NEGLIGENCE, STRICT TORT, OR ANY OTHER LEGAL OR EQUITABLE THEORY, EVEN IF ATOMIC OR SALOMON KNEW OF THE LIKELIHOOD OF SUCH DAMAGES. NEITHER ATOMIC NOR SALOMON SHALL BE LIABLE FOR DELAY IN RENDERING SERVICE UNDER THE LIMITED WARRANTY, OR LOSS OF USE DURING THE PERIOD THAT THE PRODUCT IS BEING REPAIRED.

For all warranty claims, please contact your customer service representative at:

USA 1-800-654-2668

CAN 1-800-361-3398 ext. 4113



ATOMIC RACE MODELS

Schedule of Indemnified Bindings: Atomic Race 4.12, 6.14, and 10.18 (Model years 2004/2005 thru 2010/2011)

The following images identify all model years of Atomic Race 4.12, 6.14, and 10.18 that are included on the 2013/2014 Schedule of Indemnified bindings.



Prior model years of "RACE 4.12", "RACE 6.14", or "RACE 10.18" not appearing on this poster are not included on the 2013/2014 Schedule of indemnified bindings.

**Amer Sports Winter &
Outdoor Company**

2030 LINCOLN AVE.
OGDEN, UT 84401 U.S.A.
1 (800) 225-6850

www.atomiccertification.net
www.salomoncertification.com

Amer Sports Canada

85 DAVY RD. PO BOX 909
BELLEVILLE, ON K8N 5B6

www.atomiccanada.ca
www.salomonhookup.ca

