

WHAT'S IN A NAME? IDENTIFYING CLASS A, B AND C MOTORHOMES

MotorHome

Travel, Tech, Lifestyle – For the RV Enthusiast

July 2017

INDEPENDENCE DAYS

CELEBRATE SUMMER WITH
THOR'S FREEDOM ELITE 23H

TECH TOPICS

LIQUIDSPRING
SUSPENSION
SYSTEM

AC GENERATOR
SWAP



TRAVEL THROUGH HISTORY
SOUTHEAST UTAH | BLUE RIDGE PARKWAY

UNEXPECTED LIVABILITY

10 SMALLER CLASS A'S WITH
SURPRISING COMFORT





**FORETRAVEL
MOTORCOACH**

Celebrating Our 50th Year

ih-45



The Foretravel ih-45 Just Got Better
Introducing Our Exclusive TravelRide III by Spartan

- *Extended Outboard Mounted Air Bags and 55° Wheel Cut*
- *Connected Care™ Support App and 24/7 Assistance*
- *Trussed, Torque-Box Structure With 0° Camber*
- *Hundreds of Authorized Service Centers*
- *Extreme Test-Tracked For Durability*

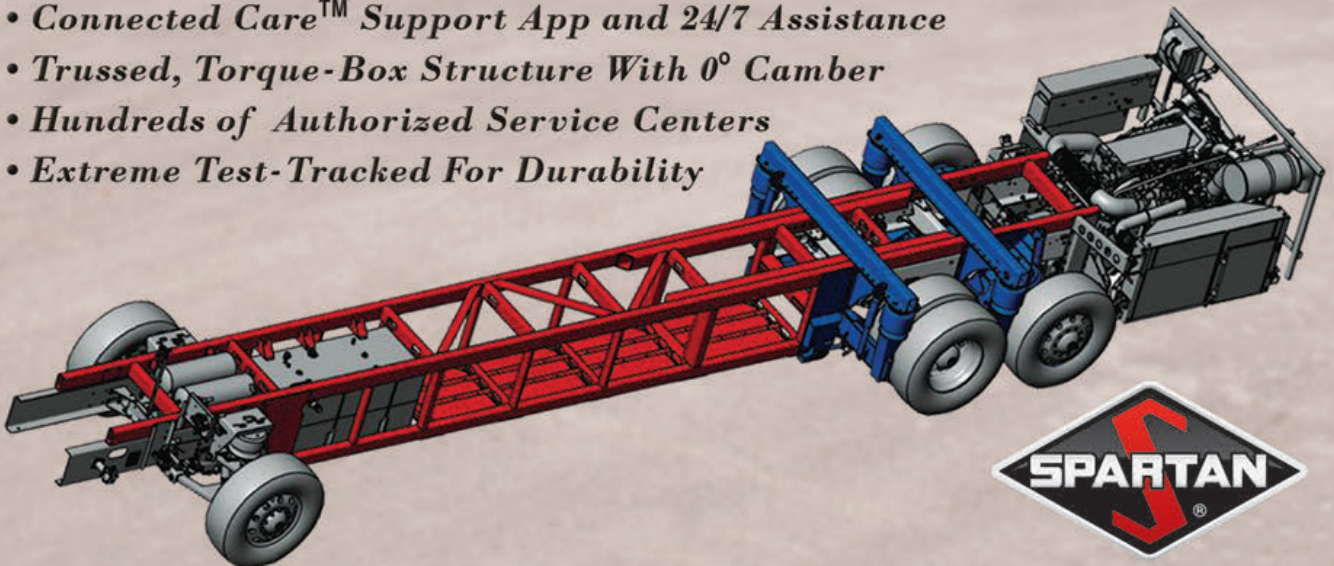

Nacogdoches, Texas

www.foretravel.com

800.955.6226

Foretravel, Circle 114 on Reader Service Card



The Virginia portion of the Blue Ridge Parkway offers RVers photo-worthy vistas including historic mills and rushing waterfalls (see page 42).



Check out these 10 motorhomes that offer the perfect balance between size and amenities. Pg. 68

6 ON RAMP

Seeing Stars

8 P.O. BOX

MotorHome readers share their opinions

15 ESCAPES

Road Foodie, Wheels & Gear, Crossroads

92 TECH SAVVY

Quick Tips, Hot Line, Coach & Powertrain

106 THE ROAD AHEAD

People and places worth the drive

FEATURES

Quebec's Gaspé Peninsula..... 25

Camp by the water, dine on fresh seafood and travel from one French village to the next ... without ever leaving North America

Written in Stone..... 32

Southeast Utah is home to fascinating petroglyphs and pictographs that offer a true window into the past

Virginia Mountain Majesty..... 42

The northern section of the famous Blue Ridge Parkway is RV-friendly and offers views of stunning waterfalls, iconic mills and plenty of down-home bluegrass tunes

Work Camping..... 51

Becoming a park host is an easy and economical way to see the country

Motorhome Nomenclature 56

What's in a name? We discuss the differences between the three classes of coaches and the pros and cons of each

The Road to Freedom 62

Thor's Freedom Elite 23H Class C combines plenty of storage capacity with quality amenities

Just Right..... 68

At manageable lengths of less than 33 feet, these Class A motorhomes offer maximum versatility and a high amount of livability

Suspension Transformation 78

A new system from LiquidSpring uses compressible liquid technology to improve comfort and handling on the Ford F-53 chassis

The Replacement..... 84

A hands-on look at installing a new Cummins Onan RV QG 4000 AC generator

The Classic Ride: Rock 'N' Roll RVing..... 89

A Wisconsin couple has set up their Fleetwood Bounder as a mobile green room to the stars

ON THE COVER

Thor's Freedom Elite 23H is easy to maneuver into most sites, including this one with a great view of the Santa Monica Mountains in Southern California (see test on page 62). Photo by Scott Hirko.





Kirby Yutzy | Welder | 23 years with Newmar



2018 KING AIRE



2018 ESSEX



2018 LONDON AIRE



2018 MOUNTAIN AIRE



2018 NEW AIRE



2018 DUTCH STAR

NEVER MASS PRODUCED, ALWAYS HANDCRAFTED

At Newmar, our 2018 lineup continues a half-century tradition of building motor coaches by hand, one at a time, with help from the dedicated men and women of Nappanee, Indiana. Individuals who believe that being the best is more important than being the biggest. And to whom superior craftsmanship is not a goal, but a way of life. Their obsession with quality and passion for innovation can be found inside each and every one of our 2018 coaches, which is why we say: *when you know the Newmar difference, you know our people.*



Explore the 2018 Newmar lineup at Newmarcoaches.com



2018 VENTANA



2018 VENTANA LE



2018 CANYON STAR



2018 BAY STAR



2018 BAY STAR SPORT

Newmar Corporation, Circle 127 on Reader Service Card



Photo: Mercedes Morgan Photography

By Kristopher Bunker

Seeing Stars

Summer is officially upon us. The kids are home from school, the sun is shining, the grass is growing, and the allure of long weekends or even short trips at the RV park is stronger than ever. And, what better time to celebrate the freedom of the motorhome lifestyle than Independence Day, with barbecues, cold drinks and fantastic fireworks displays?

Many cities across the nation offer fireworks programs, be they at a local park, stadium or at a nearby high school as in the days of my youth; a simple internet search will help locate one near you. Those trips to see multicolored mortars pierce the air with their kaleidoscope of color can be made even more special when you attend in your motorhome.

Such celebrations generally begin around noon and last into the night, offering live music, concessions and activities, all well-known benefits of the motorhome lifestyle. These holiday gatherings are a great opportunity to pilot your coach to the parking area (space permitting, of course), deploy the awning and set out some lawn chairs. Add in your barbecue grill and your own twist on a Fourth of July menu, and you have all the makings of a fantastic afternoon. As others wait in line to pay ridiculous prices for bottled water and hot dogs, you can relax in your own personal oasis, munching

on your favorite foods and enjoying a cold drink in the shade. The fact that you are a few steps away from air-conditioned nirvana, or an afternoon movie, are icing on the red, white and blue cake. These local festivities and motorhomes are definitely meant for one another.

And, after the grand finale, as others maneuver their SUVs for a spot in line to exit the facilities amid a rush-hourlike traffic jam, you can continue the fun at your spot, enjoying a cup of coffee or some other tasty treat while you wait for the crowd to dissipate.

Of course, setting up a giant 45-foot Class A may not necessarily be a viable option; oftentimes, parking at these events is in a recently graded field, where larger rigs can get stuck and clearances can be tight. Rather,

it would be the ideal time for a more compact motorhome that may be easier to drive and maneuver around other vehicles.

This month's test vehicle is a perfect example of such a motorhome. "The Road to Freedom," beginning on page 62, examines the Thor Freedom Elite 23H, a Class C that lives large with plenty of storage and features. But the fun shouldn't be confined to Class C owners: It is possible to have all the versatility of a Class C and the luxury and comfort of a Class A. As you'll read in "Just Right," beginning on page 68, many smaller Class A motorhomes offer the same amount of amenities as their larger brethren, and do so in an easier handling package. These motorhomes prove that owners need not sacrifice livability for length and maneuverability.

For me, July Fourth has always been a magical day. It never really feels like summer until my family and I are outside, under the stars, watching the fireworks light up the night, and taking the time to appreciate how great our time together really is. **M**

“It would be the ideal time for a more compact motorhome that may be easier to drive and maneuver around other vehicles.”

Contributors | July



Donya Carlson is the managing editor of *Trailer Life*. She grew up camping and loves the outdoors. Previously, she was the managing editor of the motorcycle enthusiast and travel magazine, *Rider*.



Anne Eichenmuller is a retired educator and freelance writer living in Virginia's Northern Neck. She and her husband, Eric, divide their time between sailing and traveling in their Minnie Winnie.



Emily Fagan and her husband, Mark, have been traveling full time since 2007. They chronicle their journey with lively stories and beautiful photography at <http://roadslesstraveled.us>.



Christine Goodier is a freelance writer and editor who lives in Osprey, Florida, and travels with her husband, photographer Bob Goodier, in a Class C Itasca Navion motorhome.



Angela McLaughlin and her husband, Andy, have been married for six years and have been living full time in their motorhome for nearly two years. They love exploring new places together with their pets.



Rhonda Ostertag, a freelance writer of guidebooks and articles and frequent contributor to *MotorHome*, travels and collaborates with her husband, photographer George Ostertag.

MotorHome

Publisher Ann Emerson
Editorial Director Eileen Hubbard
Managing Editor Kristopher Bunker
Technical Editor Chris Dougherty
Art Director Rick Damien
Production Director Bob Dawson
Production Manager Brenda Hutchinson
Business Manager Katey Purgatorio
Publisher Emeritus Bob Livingston

Consulting Editors Seana Dawson, Ken Freund, Jeff Johnston

Contributors Donya Carlson, Morey Edelman, Ann Eichenmuller, Emily Fagan, Christine Goodier, Bobbie Hasselbring, Chris Hemer, Scott Hirko, Angela McLaughlin, Rhonda and George Osterag, James and Dorothy Richardson, Alan Rider, Rosanne and Greg Wagstaff

Vice President National Sales Terry Thompson

RV Classifieds Katey Purgatorio
 3431 S. 257th St., Kent, WA 98032
 Tel 847-229-6756 Fax 270-495-6278
 katey.purgatorio@goodsam.com

Advertising Sales Representatives
 Sue Seidnitz (Southwest Region)
 847-229-6813, sue.seidnitz@goodsam.com

Kim Whitaker (Southeast Region)
 919-412-6325, kim.whitaker@goodsam.com

Lou Cicirelli (Northeast Region)
 954-297-9234, lou.cicirelli@goodsam.com

Scott Oakes (Northwest Region)
 Tel 847-229-6758 Fax 270-282-7356
 scott.oakes@goodsam.com

Customer Service

Subscriptions (print and digital)
800-678-1201
motorhome@cdsfulfillment.com

Website www.motorhome.com

Editorial info-motorhomemagazine@goodsam.com



President Mark Boggess
Vice President/Publisher Ann Emerson
Vice President/Advertising Sales Terry Thompson



MotorHome (ISSN 0744-074X) is published monthly by GS Media & Events (a division of Good Sam Enterprises, LLC), 2750 Park View Ct., Ste. 240, Oxnard, CA 93036. Periodicals postage paid at Oxnard, CA 93036 and additional mailing offices. The annual subscription rate is \$19.97 per year in the U.S. For Canadian and International subscriptions, add \$12 per year. U.S. funds only.

Postmaster Send address changes to *MotorHome*, P.O. Box 5860, Harlan, IA 51593-1360.

Canadian Return Address GS Media & Events, 4960-2 Walker Road, Windsor, Ontario N9A 6J3. Publication Sales Agreement #40012332.

Printed in the United States.

© 2017 Ehler Publishing Group. CAMPING WORLD and the CAMPING WORLD Mountain Logo are registered trademarks of CWI, Inc. and used with permission. The GOOD SAM ICON is a registered trademark of Good Sam Enterprises, LLC, and used with permission. *MotorHome* is a registered trademark of Good Sam Enterprises, LLC. All other trademarks are the property of their respective owners. Unauthorized use of any of the CWI, Inc. and GSE, LLC trademarks is expressly prohibited. All rights reserved.

Privacy Promise *MotorHome* will never intentionally share subscribers' names, addresses or other personal information with other companies when requested not to do so. If you want to opt out from receiving marketing offers in the mail from other reputable companies, or you opt out and subsequently desire to opt back in, contact *MotorHome* by mail, phone or email: *MotorHome* Mail Preference Service, P.O. Box 5860, Harlan, IA 51593-1360, 800-825-6861, motorhome@cdsfulfillment.com. This policy applies to postal mail; we will not send commercial emails to subscribers unless authorized to do so.

A DIVISION OF GOOD SAM ENTERPRISES, LLC

Chairman & CEO Marcus Lemonis **Executive VP** Tom Wolfe



Wireless Tire Pressure and Temperature Monitoring System

- 3 1/2" monitor—one of the largest on the market
- Sensors with replaceable batteries
- Available with anti-theft & flow-through sensors
- Monitors up to 26 tires • Handles up to 210 psi
- Both visual and audible alarms
- Fast and easy programming
- 3-year warranty • 24/7 technical support



PRICES START AT \$249

www.eezrvproducts.com 928-317-8888 510-910-5397

EeZ RV Products, Circle 111 on Reader Service Card



NeXus RV



Factory Direct Manufacturer

Bentley
Class A Diesel Pusher

Best VALUE in the Market!
Factory-direct pricing starts at \$189,999

High strength low alloy steel framing throughout motorhome – 72% stronger than aluminum!
Azdel® substrate in sidewalls and roof – No wood products!

Prices and specifications subject to change without notice.

We Build Your Dream

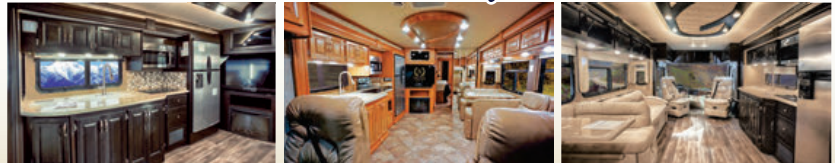

VIPER CLASS B • PHANTOM CLASS C • PHANTOM SUPER C DIESEL • GHOST SUPER C DIESEL • MAYBACH CLASS A GAS • BENTLEY CLASS A DIESEL PUSHER

Made in USA Elkhart, IN • NeXusRV.com • info@nexusrv.com • Toll Free 855.786.3987

Elkhart, IN • Clearwater, FL • Mesa, AZ
 New Castle, DE • Temecula, CA • Fairfield, CA • Ft Worth, TX

NeXus RV, Circle 128 on Reader Service Card

Is there a citizens band (CB) radio installed in your motorhome? If so, which brand/type do you have? How important was this feature when you purchased the motorhome?

Those are the questions we asked in the April issue, and here are some of the replies we received.



Ham Stake

Is there a CB radio installed in my motorhome? If so, which brand/type do I have? How important was this feature when I purchased the motorhome?

A short answer to each of the three posed questions is no. Not at all.

Please let me elaborate. Class D Citizens Band radio (CB) was established in 1958 by the Federal Communications Commission (FCC) to provide a means for citizens to communicate with each other, and with business and some industry. The rules are restrictive (but often ignored), and at first required a license (more properly termed a permit, since no test was required). The trucking industry immediately took advantage of the frequencies allotted to CB as a means for truck drivers to communicate with each other to share road conditions and (although illegally) speed traps. The rest is

history. The use of CB has waned tremendously, and the original FCC intent of providing a means for families to communicate among themselves has been replaced by other radio services, including general mobile radio service (GMRS), family radio service (FRS), and multiuse radio service (MURS). Wikipedia offers detailed definitions of each. The advent of cellular telephones and other electronic communication devices satisfies most of the need for citizens to communicate today.

CBers are a microcosm of society, and there are honest as well as not-so-honest listeners on the frequencies. In an emergency involving your motorhome, it is highly unlikely that CB radio is the only means of communication at your disposal. While cellular service does not completely blanket our country, a usable signal can usually be obtained by changing your location laterally or vertically.

If one is concerned about communicating their circumstances in an emergency, where cell service is not available, a far better solution is to obtain an amateur radio (ham) license. The exam for the entry-level technician class license consists of only 35 multiple-choice questions. Sample exam questions are available from several sources on the internet, and a few hours of study will suffice for many. Through the use of repeaters and internet links, communications using a simple hand-held radio for as little as \$30 can provide communications across town, across the country, and around the world! Many friends are made through ham radio, and the possibilities are endless. I belong to a local RV club, and of the 19 members none have CB in their rigs or vehicles, but three are licensed ham radio operators with ham radios in their motorhomes. My local ham radio club has about 30 members,

Featured Letter

CB For Safety

I classify my CB radio as part of my safety equipment. I use a Cobra 75 WX ST in my Thor 37KT motorhome as a useful way of finding out the local weather report at a moment's notice, not to mention the National Weather Service warnings/alerts for the area that I am driving through. I have also found it quite handy for finding the best route through road construction by discussing it with others. I value the security of knowing that if I cannot receive cell coverage, I am always in CB coverage and can get assistance if needed.

Scott Beaver | Fort Shaw, Montana



Everything you need is within reach.

RIVERSIDE RESORT RV PARK LAUGHLIN, NEVADA

*We're pleased to offer you the following special
MotorHome Magazine Weekly Rate.**



\$109 WEEKLY RATE

Plus...Two Complimentary Breakfast Buffets!

To Make Your Riverside RV Park Reservations
CALL 1.800.227.3849

ASK FOR THE MOTORHOME MAGAZINE SPECIAL WEEKLY RATE.

*Excludes holidays and special event periods. Subject to availability. Two complimentary Breakfast Buffets per space, per week (excludes Sunday Champagne Brunch). Management reserves all rights. Offer valid through August 31, 2017.



RiversideResort.com



and at least seven are also RVers.

I've been a ham for more than 50 years, passing my first license exam at the age of 13. The National Association for Amateur Radio may be found at www.arrl.org. I hope the readers will consider how an amateur radio license might enhance their joy of RVing, while meeting new friends. I'll listen for you on 146.520 MHz at the next campground.

Steve Czaikowski, W8SC | South Carolina

A Close Call

We have had CBs in every vehicle we have owned, and if it does not come with one then we put one in. They have saved us lots of times.

One time in particular comes to mind. We were traveling in a car and noticed for traffic had started to slow down. Immediately on goes the CB; seems there was a sniper shooting at cars about 75 miles up the highway, right where we were going. We got off the road and took side roads to get

away from not only the traffic but the sniper. Turns out that shooting started at the section of highway we would have connected to. Went out of the way several miles but got out of traffic and did not get close to a sniper.

Another time when I was traveling by myself there were several truckers that took me under their wing through several states and through a real downpour to make sure I could make it where I wanted to go. We don't always keep the CB on but when we do put it on, there are always the answers we are looking for — state of the roads, etc.

People usually ask, "Why don't you just call or use your cellphone?" First off, I don't have the cell numbers of everyone on the road around me and second, sometimes a cell signal is not that strong but the CB will always work.

Christine Allen | Via email

Ham on Tap

While we don't own a motorhome yet, I plan to install ham radios with both

local and worldwide coverage when we do. I would be interested in learning how others have installed radios and antennas (CB and ham) in their RVs.

I was surprised how cheap and easy it was to get the required licenses. I encourage current and would-be CB users to consider amateur radio.

David Kentala | Via email

More Ham

When we traded in our first RV because it was too small for us, we upgraded to a bigger unit with two slides and a few other accessories we now enjoy and wouldn't be without if we ever trade again. One thing we noticed was the CB radio that was installed by the previous owner. Ah, I will get to relive my glory days of the 1970s when I used one all the time in my car. But, alas, it is not the case. We rarely use it and the only time I use it is when we are in a parking lot on the highway so I can learn why the holdup in the stopped traffic. In our experience, it is not as useful as it was in years past as most truckers seem to be in the ham radio channels nowadays.

Allan Colgan | Via email

CB or Not?

Depending on the area of the country you happen to be in, you may not be able to use your cellphone. For example, there are no cellphone towers in West Virginia for T-Mobile, and not everyone can have roaming. This can also apply to Wi-Fi.

With CB radios you can reach help by using Channel 9 for emergencies; there are other groups that also monitor this channel. If you have problems contacting police or emergency personnel, you can search the other channels for those that have others on them. There are a lot of truckers that still use CBs for communications, plus there are a lot of people that monitor CB channels that can help you if you're lost, need help, or would like to know what the weather is like ahead of you.

Remember that CBs do have a limited range depending on terrain, but

Travel Ready

Sea Eagle® Inflatable PackFish™ 7



Reel in the big one in the small but mighty inflatable Sea Eagle PackFish 7 weighs just 21 lbs., packs down to just 20" x 20" x 5", fits easily into a motorhome basement compartment and can be carried in the included backpack to remote lakes and ponds other anglers only dream of! Unlike float tubes, waders are not required - so you fish high and dry.

Just \$399* complete with oars, inflatable seat, foot pump, repair kit and backpack.

*NY & WA residents add sales tax.



SEA EAGLE.COM
800-748-8066
 Dept. MH077B 19 N Columbia St, Ste 1
 Port Jefferson, NY 11777

Sea Eagle, Circle 138 on Reader Service Card

NIGHTHAWK

The world's first illuminated tow bar

A truly non-binding tow bar made from beautifully-styled aluminum. Embedded LED lights in each arm illuminate with the RV's lights for increased safety. What was the darkest portion of your towing system is now easily visible to other drivers, and also visible when it comes time to disconnect.



Questions about Dinghy Towing?
Call the experts at 1-800-669-9690



Patent pending



Exclusive features:

- Egg-shaped design provides amazing strength at the lightest weight.
- Recessed channel securely holds & protects waterproof LEDs from road damage.
- Enclosed channel for power cord keeps things tidy & secure.
- Channel path for safety cables keeps the clutter down & protects cables.

Key benefits:

- Easiest to disconnect in the industry with the largest hook-up radius.
- Includes safety cables and power cord that route THROUGH the tow bar!
- Heavy-duty 8,000 lb. capacity for serious towing.
- Crafted in America from aircraft-grade aluminum.

Order 676 for Roadmaster baseplates or order 677 for Blue Ox or Demco

Time Tested
Time Proven



roadmasterinc.com
800-669-9690

others with CBs can help relay your needs to others who might be able to help.

The bottom line is, the more methods of communications you have, the better, safer, and more confident you can feel when exploring.

By the way, you don't have to break the bank for a CB radio. You can have a nice one for around \$180 to \$200, and that should include antenna.

We currently have a Cobra Sound Tracker 25 WX ST.

Tim Chiles | Via email

CB For Me

We purchased a used Gulf Stream Class A in 2016. It did not have a CB installed, but we chose to purchase a Midland Micro Mobile-Portable CB (model 75-822) to use in the coach. It is both portable and hand-held, and it plugs

into a 12-volt DC outlet or can be used with a battery pack. What's nice is that it comes with an auto adapter so that all that is visible is a small hand-held unit that can lay in your cup-holder or attach it anywhere handy. The antenna connection and power plug are out of sight. Instead of an outside antenna we use a magnetic-mount CB antenna that sits on a metal coffee can lid on the dash, as I did not want to drill any holes. The radio is handy when there are traffic jams and other problems on the road. Plus, push the weather information button and get the local weather report. It has definitely come in handy and, since it's not a permanent mount in the coach, we can take it with us in the toad also.

Ed Witonski | Drasco, Arkansas

CB All the Way

Although I have an amateur radio license, and operate on the 2-meter ham band (144-148 MHz), I depend on my CB radio when traveling in my motorhome. On the 2-meter ham band I can easily communicate with other licensed ham operators — who are usually in their home — sometimes up to 30 miles away. While this may be entertaining, it is of no use out on the highways where I might need some assistance, although they might be able to call someone for me. My CB radio has a relatively short range of perhaps 2-5 miles, and the people I talk to are usually cruising along in their private vehicle or they are commercial over-the-road truckers.

The truckers monitor CB Channel 19 along with other mobile vehicles and are a valuable source of live conditions on the highway, such as reports on any vehicle accidents or anything that may be causing a delay. They can also offer a good place to stop for lunch, find a rest area or the nearest exit!

Just about any make and model of CB radio will be a good choice. Make sure it is installed properly so that it is easy to reach the channel selector, microphone, volume and squelch control, and you can do so without looking at the radio to find these functions.

It is very important to have the CB

BUY 20,000 New & Used Motorhomes For Sale By Owners & Dealers

SELL Millions of RV Buyers! Place a Free ad today

RVT.com

RVT.com, Circle 125 on Reader Service Card

antenna adjusted or matched to the CB radio transmitter. A standing wave ratio (SWR) matching device is used to physically cut the external antenna so that it is electrically matched or mated to the transmitter preferably on CB Channel 19. This procedure will ensure that all of the radio frequency (RF) energy of the transmitter will get into the antenna, and will improve the performance of the receiver.

David F. Quagliana | Williamsville, New York

Different Times

I have been an avid RVer since the 1980s, and have had CBs in almost all my units till the early 2000s; however, I have since given them up. They were very handy for road and traffic conditions and listening to truckers have interesting and sometimes funny conversations, and it helped to pass

the time during long trips.

Then the trucking industry seemed to change. The language being used by truckers wasn't/isn't fit for the radio. It's supposed to be against the law to swear on the airwaves, but of course it's near impossible to regulate. With today's smartphones and available apps, such as Waze, it's now possible to eliminate most of the reasons for CBs, though at times, I still miss them.

Jim Donnelly | Easley, South Carolina

Errata

In the "Power Players" article in the May issue, the author mentions that the Progressive Industries EMS-PT30X and EMS-PT50X are UL and Canadian UL listed. According to the manufacturer, these two models are not.

The units were also misidenti-

fied as featuring three LED lights to indicate a miswired pedestal or surge failure. They do not offer this feature. *MotorHome* regrets the errors.

I Get Around

I am new to RVing. I do not want to tow a car so my question is, "How do I get around?" I am not fit enough to ride a bike very far but have looked online at battery-powered bikes. Does anyone have experience with them, and what were the results?

David French | Alexander City, Alabama

Question of the Month

For RVers who don't tow a dinghy vehicle, what's your preferred method of "getting around" once you've arrived at your destination, both to see the local sights and to explore the RV park? Do any of you have experience with electric bikes?

Send your comments to:

MotorHome, 2750 Park View Court, Suite 240, Oxnard, CA 93036; or email letters@motorhomemagazine.com



For even more reader responses, visit:

www.motorhome.com/rv-travel-news/web-exclusive-july-p-o-box/

CUSTOM GLASS SOLUTIONS

Made in USA

Broken Windshield?
INSURANCE OR NOT
CALL US FIRST
1 (855) RVCLAIM

- Insurance Claims Processing • Nationwide Replacement Services
- #1 Supplier of OE RV Windshields • American-Made Replacement Product

rvglassparts.com • 1-855-782-5246

Guardian Windshields: Keeping you safe since 1932

GUARDIAN GLASS

Custom Glass Solutions, Circle 106 on Reader Service Card

SMI

The Original



Voted #1 Again!

Towed-Vehicle Braking Simplified

- Proven Reliability for over 20 Years!
- Zero Setup to Tow
- Universal Fit
- Proportional
- Five-Year Warranty



Thanks for voting us #1 again!

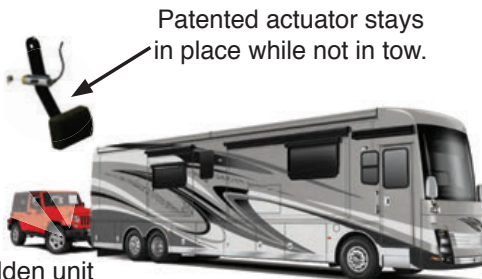

Patented actuator stays in place while not in tow.

Show off the hidden unit under your hood.



SMI Manufacturing, Circle 139 on Reader Service Card

SMI

SMI Manufacturing, Inc.
smibrake.com • 800.893.3763



U.S. PATENTS 7,693,406, 6,644,761, 6,747,675 PENDING

It's Grill Time! ↻

Char-Broil's Grill2Go utilizes TRU-Infrared technology to cook food more evenly with less flare-ups. [pg. 18](#)



16 ROAD FOODIE | 18 WHEELS & GEAR | 20 CROSSROADS



Sunset Parade

A time-honored tradition pays tribute to fallen Marines in Arlington, Virginia

by Rosanne Wagstaff

“**U**ncommon valor was a common virtue,” spoken by Adm. Chester Nimitz when describing those who fought on Iwo Jima during World War II, may be the most esteemed military quote of all time. It is inscribed on the U.S. Marine Corps War Memorial in Arlington Ridge Park, Virginia, under 32-foot-high bronze statues depicting the American flag-raising on Mount Suribachi. Against this backdrop, the Sunset Parade, a resplendent performance of music and precision drill maneuvers, pays tribute to fallen Marines — a tradition that began in 1956.

The U.S. Marine Drum and Bugle Corps leads off with a delightful military and popular music score while marching in lockstep formations. Next, the Marine Corps Silent Drill

Platoon takes the field. No audible commands are heard — just the punctuating, rhythmic slapping of bayoneted rifles against leather-gloved hands. The platoon marches in precision formations, spinning rifles in impressive maneuvers including aerial exchanges. At twilight, a lone Marine stands on the memorial's base, raises a bugle and plays the soulful notes of “Taps.”

The one-hour Sunset Parades are held Tuesday evenings in the summer. For a nominal fee, park at the Arlington National Cemetery Visitors Center and take a free shuttle to the memorial (parking is not available at the memorial on parade days). Bring blankets, lawn chairs and snacks.

For more information, call 202-433-4173, or visit www.barracks.marines.mil/parades/sunset-parade.

By Bobbie Hasselbring

Pecan Pralines, Please



Classic Southern pralines substitute the traditional almonds or hazelnuts with locally grown pecans.

When summer heats up, nobody wants to bake, but your sweet tooth may still crave a sugary treat. That's where pecan pralines come in. This Southern candy/cookie doesn't require heating your home or RV oven. It's quick to make on the stovetop and its melt-in-your-mouth goodness will make you a favorite at the RV park — assuming you share with neighbors!

Pralines (pronounced “pray-leens” or “prah-leens”) came to North America with French immigrants who settled in Louisiana, where both pecans and cane sugar were plentiful. Most food historians say pralines originated in France, where whole almonds were coated in caramelized sugar. Chefs grind the caramel-coated nuts into a powder called pralin to use in cakes, pastries and ice cream.

In Belgium, pralines are luxury chocolates (aka Belgian soft-centered chocolates, Belgian chocolate fondants or chocolate bonbons). They consist of soft, sometimes liquid, filling, made with combinations of hazelnuts, almonds, sugar, syrup and milk-based pastes in a chocolate shell.

American pralines are softer and creamier. During the 19th century, African-American cooks working in New Orleans kitchens substituted almonds or hazelnuts with local pecans and added cream to thicken, and American pralines were born. Classic Southern pralines combine sugar syrup and pecans with cream and resemble a cookie with the texture of fudge. In Louisiana, they're sometimes called “pecan candy.”

Today, pralines come in many flavors, from coconut to sweet potato. However, try the original creamy and sweet flavor first.

Pralines are made in home kitchens throughout the South. You can also purchase them online. However, pralines are especially delicious when fresh (and wonderful warm from the stove). So make some of these easy treats yourself.

Got a favorite praline recipe?

Email bobbie@realfoodtraveler.com with “Pralines” in the subject line.

SOUTHERN PECAN PRALINES



Do not double the recipe.

Prep beforehand. Once you start, don't pause or stop. Measure all ingredients and have parchment paper or a Silpat sheet ready for hot pralines.

Use a large (4-quart) pot. The ingredients will bubble.

Don't stop stirring. You want the sugar to form crystals. Stir constantly until the “pot talks,” and ingredients become thick and sugar crystals scrape against the sides.

- 3 cups chopped pecans
- 2 cups light brown sugar, packed
- 1 cup granulated sugar
- 2 cups heavy cream
- ¼ cup water
- 6 tablespoons unsalted butter
- ¾ teaspoon salt
- 1 teaspoon vanilla extract

1. Spread chopped pecans on baking sheet and toast in 350 F oven for about 5 minutes (until lightly browned).

2. In saucepan, combine brown sugar, granulated sugar, cream, water, butter and salt. Cook over medium heat, stirring constantly, to 230 F. (Lower heat if mixture threatens to boil over.)

3. Add pecans and cook (stirring constantly) to 236 F. Mixture should form a soft ball when dropped in cold water.

4. Remove from the heat and add vanilla; let stand for about 5 minutes. Stir with a wooden spoon until the mixture thickens, is slightly creamy and is less shiny.

5. Use a tablespoon or cookie scoop to spoon the pralines onto parchment or waxed paper. If the mixture becomes grainy, heat and stir over medium heat for a few seconds.



Proud winner of:

- Good Sam Rated 10/10*/10 for 2016
- 2016 MotorHome Reader's Choice Awards
- 2016 Trailer Life Reader's Choice Awards



EVERYONE LOVES A PALA RV RESORT VACATION

The votes are in, and the Pala Casino RV Resort has been named one of the best places to spend your vacation. Come discover fun and excitement in the shade of the Palomar Mountains. You'll enjoy comfort, fantastic amenities and unbelievable views. And it's just a short shuttle ride to the four-diamond luxury of Pala Casino Spa and Resort.

100 Full-Service Sites with Grass Lawns & Picnic Tables

- 77 - 30'x 55' Back-In Sites
- 06 - 30'x60' Luxury Sites with Barbecue Grills
- 17 - 30'x70' Pull-Through Sites
- 20-30-50 Amp Power
- Electric, Water and Sewer Hook-Ups
- Free Wi-Fi
- Cable TV
- Restrooms and Showers
- Key Card (for access to pool, laundry and restrooms)
- Security Patrol, 24 Hours
- Propane Fuel Available
- Free Shuttle to Casino

Luxury Resort

- Heated Swimming Pool
- 2 Spas

Indoor Amenities

- Games, Billiard Table, Card Tables
- 3 Flat-Screen TVs
- Laundromat

Outdoor Amenities

- 5 Barbecue Grill Areas
- Table Tennis
- Horseshoe Pit
- Fenced Dog Park

For Additional Charge

- Clubhouse with 2 kitchens
- Laundry - Open 24 Hours
- 3 Pets per RV (\$5 per pet - 7-Day Restrictions Apply)
- Early Check-In/Late Check-Out (based on availability)



For reservations: 1-844-4PALARV (1-844-472-5278)

Pala RV Resort: 11042 Hwy 76, Pala, CA 92059

PalaCasino.com

Located in Northern San Diego County.

From San Diego County & Riverside County: Take I-15 to HWY 76, go east 5 miles.

From Orange County & Los Angeles County: Take I-5 South to HWY 76, go east 23 miles.

Please Gamble Responsibly. Gambling Helpline 1-800-522-4700



The Trailer Life

With a motorhome, space is always at a premium, no matter how many conveniences the manufacturer has squeezed into a compact footprint. That's why SylvanSport offers its GO Camper trailers, designed to be towed by Class B motorhomes and even smaller automobiles. The GO Camper is a lightweight trailer that doubles (or triples) as a hauler/transporter/pop-up camper. The GO can be used in any of three configurations: in camping mode, which features a tent structure and versatile sleeping accommodations for up to four; in travel mode, as a low-profile gear hauler; and in transfer mode, as an open-topped utility trailer. The GO is said to weigh 840 pounds (unloaded) and folds down to an easily manageable 11 feet 11 inches by 6 feet 3 inches by 4 feet 5 inches in travel mode. The GO includes a SylvanSport Mobile Adventure Trailer and Tent System, two bed/table panels, four self-inflating mattresses and an awning kit that can expand outdoor living space by up to 80 square feet, according to the manufacturer. Cargo capacity while in travel or transport mode is said to be 800 pounds. MSRP: \$9,995.

SylvanSport, 828-393-4927, www.sylvansport.com

Look Sharp

After a day on the road, a vehicle can accumulate quite a bit of light dirt, dust and pollen, ruining that showroom shine you had worked so hard to attain. For light-duty sprucing up of a motorhome or dinghy vehicle's exterior, 3M Waterless Wash & Wax is a convenient choice for most exterior surfaces including glass, paint, chrome, plastic and metal. As the name implies, no water is needed; simply remove any heavy mud, dirt or road grime, spray 3M Waterless Wash & Wax on and immediately wipe off with a clean microfiber towel for a great-looking shine, according to the manufacturer. The product's foaming formula is designed to cling to smaller foreign matter on vertical surfaces with little mess, and it contains silicone for a glossy, smooth finish to facilitate water beading. Each can contains enough solution to clean up to three full-size passenger vehicles (or approximately one large motorhome), depending on application. MSRP: \$9.99.

3M Auto | 877-666-2277, www.3mauto.com



Grilling on the Go

To many, cooking meat (or veggies) over an open flame

is an essential part of the motorhome experience, so finding the right grill is high on the list of many RVers. At an easy-to-handle 26 pounds and measuring a compact 23.5 by 16 by 13.8 inches, Char-Broil's Portable Grill2Go X200 can easily fit into most motorhome storage bays. The LP-gas-powered Grill2Go features a Piezo Electric Igniter for easy push-button operation and the 9,500-Btu burner will have the steaks searing in no time. Grill2Go utilizes Char-Broil's TRU-Infrared cooking system, which helps cook food more evenly and with less flare-ups. The stainless-steel cooking grate can hold about 12 hamburger patties at one time, while the lid-mounted temperature gauge helps keep track of internal temps. The unit comes ready to be outfitted with a 1-pound LP-gas vessel or can be converted with a hose and adapter (\$11.99) to use a standard 5-gallon LP-gas cylinder. A custom, durable carrying case (\$69.99) also is available. MSRP: \$149.99.

Char-Broil | 866-239-6777, www.charbroil.com



Rip Stop

A damaged awning can be an expensive fix, as even a small tear can lead to a complete replacement if left unchecked. TEAR-AID Repair Patches provide a simple and easy method of patching holes and tears. Each TEAR-AID Repair Patch is made from a tough, matte-finish and abrasion-resistant elastomer designed to resist further puncturing and tearing. The patch is combined with a strong adhesive formulated for high bond strength, meaning no messy liquid adhesives or sewing are required. Once in place, a TEAR-AID patch expands, absorbing force on impact and always returns to original shape and size, according to the company. And, they're not only for awnings: TEAR-AID Type A kits also work on most fabrics, and some surprising applications such as rubber, nylon and non-oiled leather, and even on aluminum and fiberglass. Type B kits designed for vinyl and vinyl-coated surfaces also are available. Visit the website to find a retailer near you; MSRP starts around \$9.99.

TEARepair Inc. | 800-937-3716, www.tear-aid.com



Presenting the all-new Forza 38W. With accommodations for nine.

When it comes to finding a motorhome that fits your lifestyle, the right floorplan can make all the difference. That's why we offer more than 3 dozen floorplans, including the new Forza 38W. With three slideouts, two full baths and a budget-friendly price tag, this diesel pusher is sure to be a hit with families everywhere.



So whatever your family size or traveling style might be, chances are we've got the perfect floorplan for you. See them all at WinnebagoInd.com.

Drive it to your next family reunion.
Better yet, hold your next family reunion *in* it.



Miles ahead.™

Winnebago Industries, Circle 146 on Reader Service Card

©2016 Winnebago Industries, Inc.

“It works!”

We looked at a lot of options to fix the leak in our RV roof and couldn't be happier with choosing RVroof.com! They were friendly, knowledgeable, and the product works as guaranteed.

Need a New RV Roof?
RV FlexArmor® is the solution!



Art & Rose Neiderhofer
RV Type: Newmar Mountaineer A Class 1998
Installed on 06/2009
Florida



VISIT A LOCATION OR
GO TO RVROOF.COM
OR CALL 1.844.353.9276



ESCAPES CROSSROADS

Nebraska City, Nebraska

Lewis and Clark Country

The names of Meriwether Lewis and William Clark are forever linked to the exploration of the West. In 1804, the two, along with their group known as the Corps of Discovery, began their famous journey. Their goal was to find a route to the Pacific Ocean, to learn about the Native Americans along the way and to see which plants and animals lived in the West.

In June of 1804, the expedition first came near to modern-day Nebraska City. This area holds much significance in the duo's history. The Lewis & Clark Missouri River Visitors Center is one of Nebraska City's most interesting attractions. Overlooking the Missouri River, the 12,000-square-foot center sits on a scenic 79-acre bluff and highlights the Indian tribes, animals and plants the group encountered. Outside the center is a life-size replica of a keelboat the Corps may have used, and an earthen Indian lodge.

For more information, call 402-874-9900, or visit www.mrb-lewisand-clarkcenter.org and www.nps.gov/lecl. — *James and Dorothy Richardson*



Photo: James Richardson

Camden, New Jersey

Battleship New Jersey

The world's largest and most decorated battleship is available to tour. Launched from the Philadelphia shipyards (just across the Delaware River from where it now is docked) on December 7, 1942, the USS New Jersey served until February 1991. Its long career began in the Pacific theater during WWII, including being the flagship of the Fifth Fleet. The New Jersey also proudly served in the Korean and Vietnam wars. After being decommissioned, the ship was brought back to Camden, New Jersey, for its final resting place.

Begin your tour with a stop at the visitor center, then proceed on board for the self-guided "Fire Power

Tour." The New Jersey is nearly three football fields long and more than 11 stories high. Be prepared for some climbing and descending of steep stairs (wear comfortable shoes, and no strollers are allowed on board), all on the quest to explore this great ship much like the officers and crew of the battleship once did. Check out all of the huge guns, the electronics of the past, officer and crew living quarters, the bridge and even the mess hall, where you can get a snack.

Parking is available just adjacent to the ship. For larger motorhomes, contact the visitor center for specific locations that will accommodate a big rig.

For more information, call 866-877-6262, or visit www.battleshipnewjersey.org. — *Morey Edelman* 



Photo: Morey Edelman



TRAVEL SAFER WITH A BUDDY!

PORTABLE TOWED VEHICLE BRAKE SYSTEMS

DIGITAL CLASSIC™

THE ORIGINAL BRAKE-IN-THE-BOX
THE SYSTEM THAT CREATED AN INDUSTRY

- Industry standard for dependability and has more miles of experience than all others combined
- Full braking technology
- Works on all towed vehicles



VANTAGE SELECT™

THE ULTIMATE IN PORTABLE BRAKING

- One touch start up button
- “On-the-fly” sensitivity adjustment from the coach
- Choose between full or proportional braking
- Simply adjust unit from driver's seat of coach with interactive remote
- Works on all towed vehicles



THE MOST TRUSTED NAME IN BRAKING

Making the RV Towing Experience
Safe, Simple and Hassle Free!

3 YEAR
WARRANTY

30 DAY
MONEY BACK
GUARANTEE

DREAM IT, MAP IT, GO

Two travel tools tap into Good Sam's deep reservoir of trip-planning data

With travel season in full swing, members can let the Good Sam Club sweat the details on RV trips this summer and beyond. Two free travel tools, the Good Sam Trip Planner and Camping App, put the club's vast resources at members' fingertips for fun, hassle-free road trips. Both tools are easy to use and provide detailed maps, extensive campground information and access to Good Sam's exclusive RV park ratings and member discounts. Simply type in the destination and travel preferences, and Good Sam does the rest.



TRIP PLANNER

Using resources from the Good Sam Club and trusted mapmaker Rand McNally, the Good Sam Trip

Planner plots RV itineraries on the club's website. The online mapping tool harnesses Good Sam's database of 12,000-plus RV parks and services and three-tiered campground ratings, and identifies Good Sam Parks, Pilot Flying J fuel centers, Camping World SuperCenters and other locations that honor member discounts along the route. After searching for RV parks, users can scroll through campground photos, amenities and services, and plan the best route.

► **GET GOING:** From www.goodsamclub.com, select Trip Planner from the Plan a Trip menu and type in your departure place and destination. Trip Planner creates point-to-point directions, and a calculator provides the approximate cost



Creating vacation itineraries and making lasting memories is easy with Good Sam's online Trip Planner and mobile Camping App.

of fuel consumption. The search can be filtered to indicate low clearances and propane restrictions, and to find shopping, restaurants and festivals as far as 60 miles from the route. Click on any RV-park map pin, and a pop-up will show campground ratings and amenities. When you choose to include Good Sam Parks along your route, they are indicated by the club's halo-topped mascot.

CAMPING APP

The Good Sam Camping App puts the club's resources to work on smartphones and tablets.

► **GET GOING:** From Apple's App Store or Google Play, load the free Good Sam Camping App to your Apple or Android mobile device. To launch a campground search, enter your destination and filter the results based on preferences that include Pets OK, Swimming, Internet, 50 Amps and Open All Year. Then select an RV park and click on Map View to find out how to get there. Smartphone users can tap the phone number in each listing to call parks instantly for more information or to make reservations. To zero in on Good Sam Parks and other member-discount locations, tap on the map pins for more information.



Stock up for the season and save.



Salute to Summer: Everything Under the Sun

Camping World welcomes the season with a June 22 through 25 sales event at its more than 120 retail and service locations. Sponsored by Dometic, the four-day Salute to Summer features special offers on a variety of RV parts and accessories, outdoor gear and newly expanded lines of housewares and pet supplies. Customers receive a free pair of patriotic sunglasses with in-store purchases of \$75 or more, while supplies last. Free lunch will be served June 23 and 24 from 11 a.m. to 1 p.m.

► Visit www.campingworld.com to find Camping World SuperCenter locations, maps and driving directions, and to shop online.

PUMP UP THE FUEL SAVINGS

Just in time for summer RV trips, Pilot Flying J has boosted its fuel discounts for Good Sam Club members. Members can now swipe their Good Sam card at the time of purchase and save 5 cents per gallon on gas and 8 cents per gallon on diesel when filling up at most Pilot and Flying J locations. That's a 2-cent increase on the previous gas savings and a 5-cent bump on the diesel savings.



FREQUENTLY ASKED QUESTIONS

What form of payment can I use when purchasing fuel?

Use your own choice of payment in conjunction with your Good Sam Club membership card to receive savings at the pump. The discount comes off the cash or credit price, depending on what form of payment you use.

Does the membership fuel discount apply to any amount of gas or diesel?

Yes. The discount applies to any volume of fuel you purchase.

Does the fuel discount apply in the truck lanes?

Yes. To save on diesel fuel when using the truck lanes, prepay inside and have your membership card scanned at the time of purchase. The 8-cent diesel savings at the truck lanes will be taken off the cash or credit price, depending on how you pay. Fuel savings are applied instantly at the pump when filling up in the RV lanes or other fuel lanes, and you do not need to go inside to pay the cashier.

Can I use the “start the pump” feature and get the fuel discount?

Yes. Tell the cashier you would like to sign up for Easy Fuel or Pump Start at the truck lanes using your Good Sam

membership card. You will be required to provide your driver's license. The next time you fill up, insert your membership card in the pump at the truck lanes and enter the store to pay the cashier after the tank has been filled.

Why isn't the fuel discount available in all states?

Laws prohibit fuel discounts in some states.

Why isn't the fuel discount available at some other locations?

Independently owned Pilot Flying and J locations can opt out of discount programs. These locations do not offer Good Sam Club discounts on gasoline, and cashiers will not accept membership cards for fuel savings. Dealer locations do offer the diesel discount at the truck lanes but only for transactions started at the pump.

Do all Pilot and Flying J locations offer RV fueling lanes?

Almost all Flying J locations offer RV lanes. About 40 Pilot locations offer RV lanes. New locations will have RV lanes and other RV amenities such as dump stations and bulk propane.

Note: Other terms and conditions may apply.

HOW TO SAVE AT THE PUMP

Step 1: Insert your form of payment at the fuel pump.

Step 2: Swipe your Good Sam Club membership card (aka “loyalty card”).

Step 3: The savings are instantly applied to the fuel purchase.

PILOT FLYING J SAVINGS

Gas/U.S.....	5¢ per gallon
Diesel/U.S.....	8¢ per gallon
Gas and Diesel/Canada	1¢ per liter
Dump-Station Fees.....	\$2.50
Propane	5¢ per gallon

► Visit www.goodsamclub.com/pfj or www.pilotflyingj.com, or download the Pilot Flying J mobile app, myPilot, for more information and to find Pilot and Flying J locations that offer gas and diesel discounts and those that offer diesel discounts only. With a network of locations throughout North America, Pilot Flying J is the official fuel provider and travel center of the Good Sam Club.



Ⓞ DID YOU KNOW? Forty-five years ago, Good Sam published its first guide to RV parks, the 1972 *Recreational Vehicle Owners Directory*. Thirty-nine years later, Good Sam's annual guide merged with the Woodall's campground directory, first published in 1948. Now known as the *Good Sam RV Travel & Savings Guide*, the 2017 edition lists 11,962 RV parks and campgrounds.

Eliminate "White-Knuckle" Driving!

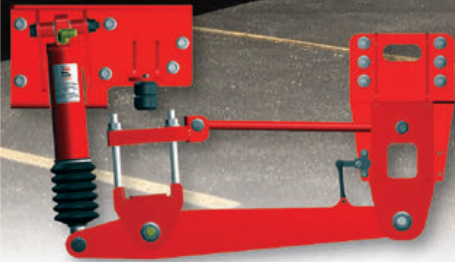

- ✓ Reduces Road Vibration by 35%
- ✓ Reduces Body Roll by 41%
- ✓ Less Fatigue for the Driver
- ✓ Less Wear & Tear on Your Vehicle
- ✓ Greater Resale Value
- ✓ American Made

Recreational Vehicle Suspensions – Travel America in Style with a Smoother Ride

CLASS® suspensions significantly improve ride, handling, safety AND provide an improved overall driving experience. Available for Class A and Class C coaches.

*Suspension Solutions Today
for Tomorrow's World*

Get the whole story at liquidspring.com





Church steeples rise above each waterfront town in the Gaspésie.

Quebec's Gaspé Peninsula

The scenic Canadian province offers authentic French charm close to home

By Christine Goodier

Camping by the water, eating fresh seafood and driving from one French village to the next? Sounds like a bucket list summer vacation to me. But my husband, Bob, and I weren't up for the hassle of flying to Europe after a hectic year. Instead, we loaded our 25-foot Class C motorhome and drove to Canada's Quebec province seeking relaxation and a taste of France much closer to home.

After an easy border crossing on Interstate 87 from New York we drove north along the St. Lawrence River from Quebec City to the town of Rimouski for food, fuel and a point of interest: the Pointe-au-

Père (father point) Lighthouse National Historic Site. Arriving in a cool drizzle, we ducked into a museum to learn about "Canada's Titanic," a Liverpool-bound ocean liner called the Empress of Ireland. Early on the morning of May 29, 1914, some 1,012 people died when it sank in 14 minutes after being rammed in the fog by the Norwegian coal ship Storstad.

After watching a multimedia presentation (offered in both French and English), we looked at cases of artifacts — a wooden deck chair, china plates, a ship's bell, a baby bottle and more — brought to the surface by divers from wreckage that still lies 130 feet down on the river floor just 5 miles offshore.

We crossed the street to see the Pointe-au-Père Lighthouse built of concrete in 1909 in an

Getting There ➔

Quebec City is located more than 500 miles from New York City, New York. The following route includes toll roads. Take Interstate 87 North for approximately 117 miles. Take exit 24 toward I-87N/I-90E toward Albany/Montreal, continue 177 miles and merge onto I-87N. Continue onto Autoroute 15N. Take exit 40 for Autoroute 30W, then continue onto Autoroute 930E. Merge onto Autoroute 30E. Take exit 83 for Autoroute 20E. Merge onto Route Transcanadienne/Autoroute 20, then exit 312N for Autoroute 73N. Take exit 139-E for Autoroute 440E/Autoroute Charest E toward Quebec.



GETAWAY

QUEBEC'S GASPÉ PENINSULA

unusual flying-buttruss design that soars 108 feet to the top. Tickets to the site gave us the opportunity to climb its 128 steps on a guided tour and to walk through the nearby Onondaga, a decommissioned submarine that served the Royal Canadian Navy from 1967 to 2000.

Driving 11 miles to our campground, we entered the Gaspésie region on coast-hugging Highway 132, our clockwise route for the next 10 days. At St. Flavie, we pulled into Capitaine Homard ("lobster captain"), a seafood restaurant with 48 adjacent campsites, an appropriate start for touring a lobster-claw-shaped peninsula famous for its seafood.

A full-hookup site facing the river was ideal for relaxing and enjoying sunshine and fresh breezes after sweltering temperatures back home. We walked out onto the rocky, wet flats during low tides, feasted on steamed lobster, watched spectacular sunsets and joined other RV travelers building a fire on the black pebble beach.



Photo: Le Québec maritime/Marc Loiseleur

The Anse-Blanchette heritage site at Forillon National Park re-creates early settlers' lives.

"What does that 'Post de Vidange' sign mean?" I asked my husband one morning while walking the dog. Since he had no idea either, I consulted Google Translate and laughed to learn that we had found the dump station. Despite our lack of French language skills, we could easily communicate and navigate, converting kilometers

to miles for road signs and litres to gallons at fuel pumps. In a year with an unusually favorable exchange rate, our American dollars were going a long way.

The well-maintained Highway 132 led us through one simple village after another, each with a pointed church spire and string of pitched-roof

Quebec City's landmark Chateau Frontenac Hotel towers above the St. Lawrence River.



Quebec City

For a pre-Gaspésie immersion into the province's French heritage, stop first at Quebec's charming capital. A convenient base, Camping Transit, in the suburb of Levis across the St. Lawrence River, has full-hookup sites and a free shuttle service to the nearby ferry dock. Keep your camera handy as the ferry approaches the city for a magnificent view of the landmark Chateau Frontenac Hotel in the Upper Town, easily reached by a funicular railway. Spend an absorbing day on foot exploring, shopping and lunching in the upper and lower sections of Vieux-Quebec, the old city.

cottages trimmed in white fretwork. Rainy days were brightened by roses, buttercups and lupine growing wild by the road, and blue fleur-de-lis flags of the Quebec province flapped in the breeze everywhere we went.

Many towns had a bakery, cheese shop or poissonnerie — the latter of which is a fish market, with salmon, snow crabs, mussels and other seasonal goodies. To round out our pantry, the chain of well-stocked IGA grocery stores had vegetables, wine and parking lots spacious enough for even large motorhomes.

Scenery changed one morning after we left a campground in the small city of Sainte-Anne-des-Monts. Craggy mountains loomed above the curving highway, waves sprayed the road to our left, and waterfalls streamed down on our right. Around a bend, the red La Martre Lighthouse stood out against the gray clouds and we drove up to take a look. Built in 1906, the wooden octagon stands guard, automated now but still capable of rotating its Fresnel lens in a pool of mercury by a system of weights and cables.

An hour back on the road revealed blue skies and a white lighthouse, guardian of the Cap-de-la-Madeleine coast since 1871. Managed by volunteers, the Sainte-Madeleine-de-la-Rivière-Madeleine Lighthouse has a cafe, a small museum and the temptation of dry camping on the

grounds. But with even more lighthouses to see, we continued driving, now encountering steep grades. Pulling off at hilltop rest areas brought photo opportunities, like Grande-Vallée, where the church of Saint-François-Xavier perches on a plateau in a cove below.

A rain-gouged, gravel side road led us up to our reward: the cast-iron Pointe-à-la-Renommée Lighthouse, known to be one of the prettiest in the Gaspésie. Its bright crimson tower was surrounded by shingled wood buildings, green grass and views to the sea below. Called “the world’s most traveled lighthouse,” Pointe-à-la-Renommée was sent to Quebec City’s old port in the 1970s as a tourist draw but returned to the cliff in 1997 following a citizens’ campaign to get it back. Replicas of the lightkeeper’s house and a 1904 Marconi wireless station now house museums.

After a busy day on the road, we reached the spot where the St. Lawrence River ends and the Gulf of St. Lawrence begins, guarded by the white marble-clad Cap-des-Rosiers Lighthouse, Canada’s tallest. Named for the area’s wild roses by French explorer Samuel de Champlain, who mapped the St. Lawrence River in 1603, the “cape of roses” now marks the entrance to our destination for Canada Day weekend: Forillon National Park. After checking in and buying firewood at the interpretation



Drive up a steep road to find Pointe-à-la-Renommée Lighthouse.

xantrex™
Smart choice for power™

A NEW
XANTREX
IS ON ITS WAY

FREEDOM X SINE WAVE

JULY 2017

Xantrex, Circle 148 on Reader Service Card



CRUISERLIFT.COM
866-794-8357



SWIVELWHEEL.COM
866-794-8357

Fast Master Products, Circle 112 on Reader Service Card

The Last LEAK You'll Ever Have... The Last ROOF You'll Ever Need!

**100%
MAINTENANCE FREE**



10 YEARS to get this

- No Caulking Roof Vents, Seams or Skylights
- No Streaking • No Leaks...EVER!

Beautifully finished seamless roof



3 DAYS to get this!

- ✓ 10 Year Material & Labor
- ✓ No Leak Guarantee
- ✓ Work performed at our location or yours
- ✓ Financing Available

RV ROOFING SOLUTIONS

888-847-7010

www.rvroofingsolutions.com

Call for FREE Information Kit

Booking appointments

**June, July & August
Northern California, Oregon &
Washington State**

**Sept. & Oct. Midwest, East
Coast & Southern States**

**Franchises Available
www.RVRoofingFranchise.com**

GETAWAY QUEBEC'S GASPÉ PENINSULA



In the Percé harbor, a pierced limestone island rises 289 feet. A must for Percé visitors is viewing the Île-Bonaventure-et-du-Rocher-Percé National Park by boat. At Anse-Blanche, learn about families who once farmed and fished in today's Forillon National Park.



center, we plugged into a 30-amp site we reserved months ahead at Des-Rosiers Campground.

The next morning Bob started off on a hike along the Les Graves trail past coves and beaches that would lead to a lighthouse and Land's End, the tip of the Cap-Gaspé peninsula. Whales spouted offshore, porcupines climbed trees, and a big-eared, young black bear cub greeted him on the two-hour hike. Meanwhile, at the Grande-Grave National Heritage Site, I toured restored homes and a general store that re-create the lives of fishing families who once farmed by the water.

In the evening we walked down the short campground path to a pebble beach for sunset views of the soaring cliffs, and over dinner talked about Forillon's diverse beauty. Bob had seen sheets of fog roll down the mountains, while I had watched a chipmunk find breakfast in a patch of tiny wild strawberries. As if on cue, a brown porcupine lumbered through our campsite and climbed a tree.

After admiring the soaring seascapes of Cap-Bon-Ami cliffs the next day, we hiked the 1-kilometer (0.6-mile) La Chute (waterfall) trail



humorously described as "beginner" level. To recover from the steep trail without handrails and to prepare for the climb back up, I lingered awhile at the 56-foot-tall waterfall in a large red chair. Parks Canada places them at especially scenic locations, and there were many in Forillon.

Another jewel of the Gaspésie awaited us back on Highway 132 in the fog-shrouded town of Percé. Bob plugged into our full-hookup site at Camping du Phare in a drizzle, and we slept soundly. The next morning's bright sun revealed spectacular campground views of the water and clear weather for a boat ride. We reserved two seats on a 9 a.m. departure from the town wharf since,

#LETSJAYCO



QUALITY TIME MEETS TIMELESS QUALITY

From day one, Jayco has set out to build a better, more comfortable RV. And ever since, whether in a pop-up camping trailer or a luxurious motorhome, families have counted on us to help them shape the stories that last generations. Nearly 50 years and millions of memories—that's the Jayco story. What's yours?

Visit Jayco.com to learn more and find your nearest dealer.



Generations of family fun.

Jayco, Circle 121 on Reader Service Card

DIESEL TOWN TEXAS

Airstream Touring Coaches



Leisure Travel Vans



Exclusive Dealer in Texas!

Midwest Automotive Designs



Tiffin Motorhomes



Full-Line Dealer!

VOGT

RV CENTERS

Airstream - Allegro - Jayco
Tiffin - Leisure Travel Vans
Midwest Automotive & More!

VOGTRV.COM

817-831-4222

GETAWAY

QUEBEC'S GASPÉ PENINSULA

like most other visitors, we wanted a closer look at Île-Bonaventure-et-du-Rocher-Percé National Park.

Our captain headed first to the famous pierced rock in the harbor. Rising 289 feet in the harbor, this limestone island has been around at least 375 million years, and caught the attention of explorer Samuel de Champlain, who named it in 1607 for the 49-foot-tall natural arch at one end. After giving us views of Rocher-Percé from all sides, our captain headed through increasingly rough seas toward Bonaventure Island.

With plenty of outdoor space on the double-decker boat, we took photos of thousands of birds along the rocky cliffs. A naturalist on board explained that about 120,000 northern gannets and at least 10 other species, including common murrelets and black-legged kittiwakes, are found on Bonaventure, one of the most significant and easily reached gannet colonies in the world.

On calm days, passengers can land at the island's dock, view restored homes and hike across the island to view the northern gannets up close, but our captain wisely decided to turn back to town. He offered the option to go back on a later boat but we decided instead to stroll through the shops and galleries of Percé and indulge in soft-serve ice cream cones.

We celebrated the July Fourth evening with grilled steaks and set out our camp chairs to drink in our panorama of a lighthouse behind us and the town's two islands in front of us. The pierced rock glowed in a pink and lavender sunset and, inside after dark, we watched the sparkling lights of the town through our windshield.

After three relaxing days we headed out again and soon realized that the French atmosphere of the province was becoming more English along the south coast. Signs, Anglican churches and place names like New Carlisle and New Richmond graced this area where descendants of Irish, Scottish and loyalists joined earlier Acadian settlers.

We pulled into our final campground at a modern resort



Photo: Le Québec maritime/Marc Loiselle

Find camping along coastal Highway 132 for St. Lawrence River views. Hike across Bonaventure Island for an up-close view of the northern gannet colony.

and marina operated by the town of Carleton-sur-Mer. Our waterfront full-hookup site was by the beach at the end of a strip of land jutting into Chaleur Bay with the Chic-Choc Mountains looming above. The complex promised a full menu of outdoor activities: golf, hiking and cycling, as well as water sports like windsurfing, kayaking and boating.

But high winds and a rainy spell left us content to watch whitecaps on the bay from inside our cozy RV. We had come to the Gaspé Peninsula for relaxation and had found it, and more. Spectacular views, easy navigation, waterfront camping and plenty of fresh seafood all added up to a perfect summer vacation — with just the right touch of French flair. **M**

FOR MORE INFORMATION

Reservations are rarely needed, but call ahead if you plan to visit around St. Jean Baptiste Day (June 24) and Canada Day (July 1).

Camping Campground Transit
888-882-0948, www.campingtransit.com

Camping du Phare a Percé
877-332-5588, www.campingduphareaperce.com

Carleton-sur-Mer
418-364-7073, www.carletonsurmer.com

Capitaine Homard
418-775-8046, www.capitainehomard.com

Forillon National Park and Des-Rosiers Campground
888-773-8888, www.pc.gc.ca/eng/pn-np/qc/forillon/index.aspx

The **Fiesta Heavy Duty (HD)**™

The best just got better!



The Fiesta Heavy-Duty (HD) is the next great addition to the Fiesta Awning Series. The Fiesta already boasts the strongest arm channels and the longest life of any spring loaded awning available today. The Fiesta HD is taking the best and making it even better.

The Fiesta HD includes enhanced metal Travel Locks, Remote Locks and Canopy Clamps which come in Carefree's signature orange HD hardware. All Fiesta HD hardware and components can be easily retrofitted onto your current Fiesta awning.



Metal travel locks shown open (left) and closed (right).



Metal Canopy Clamps keep your awning tight & wrinkle free.

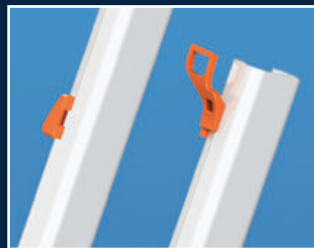

There's no reach with Carefree's metal Remote Lock.



New! Carbon fiber design

Don't forget to protect your fabric with Carefree's FLXguard™

Quality • Value



Performance • Style

For more information about Carefree products, please visit us at www.CarefreeOfColorado.com

Carefree of Colorado, Circle 105 on Reader Service Card

By Rhonda Ostertag

WRITTEN IN

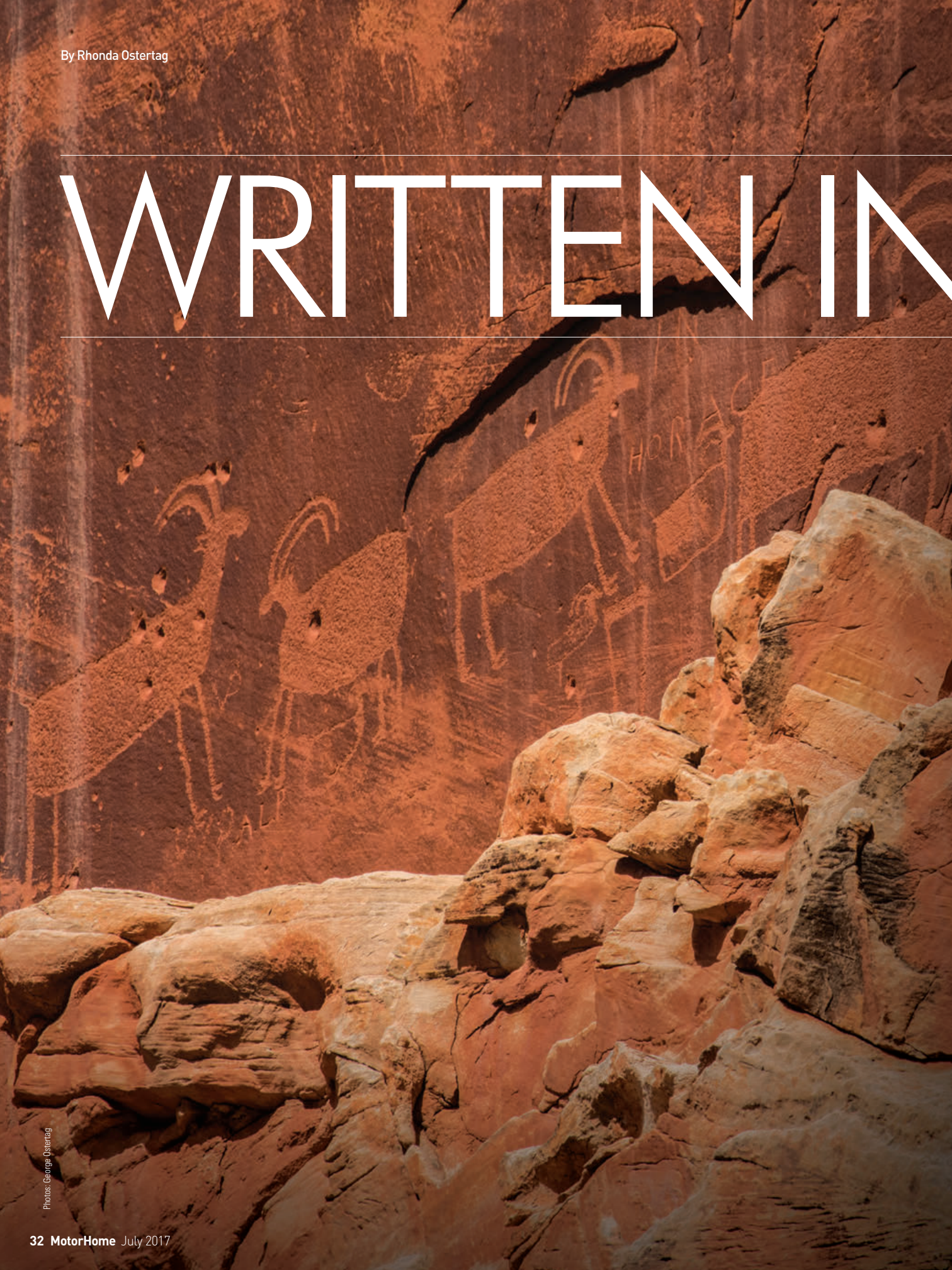

Photos: George Ostertag

STONE

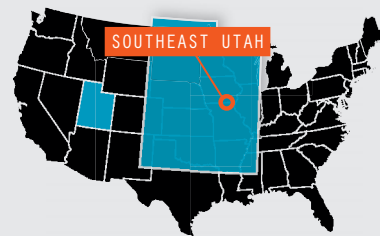

Getting There

To reach the author's first stop, Nine Mile Canyon, take 2200 East (Soldier Creek Road) north off U.S. Highway 6/191 at Wellington (southeast of Price, northwest of Green River). An interpretive sign for Nine Mile Canyon sits near the turnoff.

Ancient red-rock images in southeast Utah offer a true glimpse of history

There are many reasons for visiting the red rocks of Utah, but for me the rock art was the organizing theme. Utah has some great, unspoiled ledgers from peoples past, both Native American and pioneer.

The etched (petroglyph) and clay- and herb-stained (pictograph) images represent the early journals, newspapers and letters home. They are ballads in stone of great expeditions and heroic conquests and spiritual visions. Yet, the rock art lives in mystery, as interpretation did not pass forward.

Images count in the hundreds, even thousands. Several depicted spirits would be right at home at an intergalactic bar in a "Star Wars" film. Elsewhere, walls tell of everyday hunters. Bighorn sheep, buffalo, elk and deer share space with centipedes and frogs. Some images are life-size, while others exceed human dimension. All engage imagination. Southeast Utah holds a wealth of these records.

Art panels can be reached by paved road, graded road and foot trail. Several lie within national parks. While ping-ponging between sites, travelers can revel in the red-rock grandeur, which spills beyond park borders. Vistas, trails, ruins, dinosaur tracks, Mormon pioneer history and early enterprise

broaden the template. Camping is available within national and state parks, and at private campgrounds and RV parks. Moab is the area's urban center for full service. Supplies and fuel are generally available in smaller towns.

The following sites should help get you started. All can be reached by dinghy vehicle or small motorhome, with careful attention to road conditions and weather. Calling ahead for current conditions is never a waste of time. Vehicles should be in good repair, with fuel tanks topped off and a usable spare tire or two on hand. Carry

food and plenty of water. Binoculars are golden for appreciating art detail.

Treat each site as a fine-art museum because that's what it is. This calls for best manners. Oils from fingertips cause damage. Sadly, too many sites have suffered the destructive hands of vandals and misguided admirers.

Green River Area Nine Mile Canyon

Before arriving at this most out-of-the-way art site we visited, check out <http://climb-utah.com/Misc/index.htm>. This BLM backcountry byway traces a rugged canyon route built by the all-African-American Ninth Cavalry and has served stagecoach, mail, freight and telegraph. It is paved or sealed to



Left: Petroglyphs, like these at Capitol Reef National Park, are etched rather than stained. Right: The trip to Nine Mile Canyon is well worth the extra effort.

Keep adventure beautiful

With Tabless Baseplates
EXCLUSIVELY
from Demco

800.543.3626
www.demco-products.com

Your New

Dealer

Celebrating 100 years!

Since 1917
Steinbring
MOTORCOACH
Garfield, MN
Toll Free 1.877.880.8090
320.834.6333
View inventory at:
www.steinbring.com

WRITTEN IN STONE



Balanced Rock is another popular attraction at Arches National Park.

Duchesne but becomes more narrow and winding past the Great Hunt Panel at 46 miles, where we ended our visit. Gravel spurs (passenger vehicles only) expand viewing.

Because big trucks use the canyon route, drive cautiously and park off the road. A couple of turnouts have vault toilets and picnic tables.

Initial travel is through private land. Be on the alert for mule deer and cows, and use care at road dips. At the 24-mile mark, Nine Mile Ranch offers primitive RV camping, a bed-and-breakfast, authentic pioneer cabins and guided tours (435-637-2572, <http://9mileranch.com/campgrounds>).

Find the first of a dozen accessible art panels at the 26-mile mark. A small wooden fence marks the site. More than 1,000 such sites have been cataloged. The art traces to the canyon's Fremont Indians. Village sites

and cliff-ledge granaries further hint at their existence, although they may be hard to discern.

The diversity and quantity of the images strain belief. Birds, deer, dogs, horses and riders; snakes and snaking lines; dots, hands and feet; and baskets and pots hint at ancient stories. Daddy Canyon (at 44 miles)

UTAH ROCK ART, STYLES

Rock art is a reflection of the lives and beliefs of the artists.

[1] Barrier art (6000 B.C.-100 B.C.) reflects a nomadic people, who hunted large and small game and harvested wild plants. They occupied caves or temporary structures. Their artistic, larger-than-life, distorted human forms reflect a shamanic or spiritual presence.

[2] Fremont art (A.D. 600-A.D. 1250) represents the Fremont Indian culture. This agrarian people planted corn, lived in pithouses or piled-stone shelters and fashioned basketry and pottery. Their humanlike figures may exhibit rectangular bodies. Mountain sheep and abstracts are common.

[3] Ute art (A.D. 1300-A.D. 1880) can be identified by horse and rider figures and bison. Utes were hunter-gatherers, using bow and arrow, baskets and pottery. They dwelt in brush wickiups and tepees.

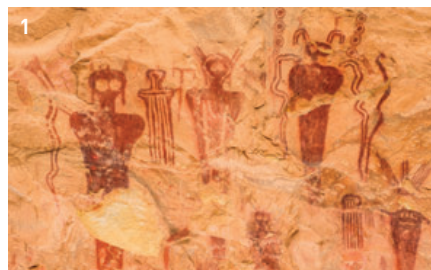

The Look of the Future

Newmar's King Aire features HWH's innovative slide-outs providing true flush floors and smooth exteriors.



The HWH® slide-out mechanism, featured on the new Newmar King Aire and other Newmar models, provides a **true flush floor** with its **no-touch, up and out operation**. The innovative design also eliminates the typical need for gap-hiding carpet that is easily soiled, damaged or marked by slide-out rollers.

Be sure to experience this feature at your Newmar dealer!

Made possible by the strength of Newmar's STAR Foundation and HWH's flat floor slide-outs, **Newmar's "More Floor"** feature is an engineering and production masterpiece which provides amazingly spacious livability with beautiful flat floors of porcelain tile in the kitchen, living and bedroom slide-outs.

Other HWH® features on this 2016 Newmar King Aire Luxury Motor Coach include: HWH BI-AXIS® Touch Panel Controlled Hydraulic Leveling, HWH SpaceMaker® Universal Platform Level-Out (UPLO) Slide-Out System and the HWH® Generator Slide-Out System. For more information on this coach go to www.NewmarCorp.com



Made in the USA since 1967
800-321-3494
HWH.com



RV Armor Lifetime Roof



leak and worry-free FOR LIFE.

- ✔ **Lightweight:** Seamless, and maintenance-free
- ✔ **Convenient:** Don't Move! We'll come to you and install your new roof. Two-day process with nationwide service.
- ✔ **Affordable:** Less expensive than a traditional roof replacement
- ✔ **Permanent:** Lifetime material and labor warranty. Tracked by the VIN #



www.RV-ARMOR.com

Call 855-RV-ARMOR (855-782-7667)



RV ARMOR is a Federally Registered Trademark of RV Armor, Inc. All Rights Reserved.

WRITTEN IN STONE

holds impressive art panels, one shaping the fourth wall of a corral. Behind one boulder hides a buffalo image. More art leads into this side canyon and across the wash.

The Great Hunt dishes up a worthy climax, with its herd of square-bodied wild sheep and lambs, large floating archer and prominent central figure with horns and trapezoid body. Its developed parking is 0.2 mile past the short trail to Big Buffalo Panel.

Dispersed images throughout Nine Mile Canyon offer chance viewing. Search the smooth surfaces and black varnished walls, at eye level and above.

Sego Canyon

At Thompson Springs, east of Green River off Interstate 70, driving north on Sego Canyon Road leads to a fantastic BLM rock art site. For 3.5 miles on old asphalt, changing to dirt, the greeting is like a prehistoric drive-in picture show on a big rock screen. A day-use parking area and toilet serve visitors.

Despite fading, the Fremont- and Barrier-style anthropomorphic

forms captivate with size. One wall features 19 of the side-by-side sci-fi characters with masklike faces, horns and antennae. Armless mummies stand with beings with snaking arms and tapered floating forms. Elsewhere, Ute images adorn the rock. Interpretive panels aid understanding.

Just up the canyon and across the cattle guard, you can see from the road a decorated wall on private land (no trespassing). Use binoculars to better the view.

Capitol Reef National Park

On state Route 24, this park, 85 miles southwest of Green River (35 miles west of Hanksville), holds messages of early settlers as well as Native peoples.

Admiration of its petroglyph panel (off Route 24, 1.1 miles east of the visitor center) is by boardwalk and a viewing platform with scopes. The Fremont-style art shows wonderful size, with several characters displaying big hands and feet. Running sheep stretch across a good length of panel. Push-button recordings provide a

HORSESHOE CANYON

This remote reach of Canyonlands National Park holds bucket list-worthy, culturally significant rock art that requires commitment to see — a lengthy, lonesome, dry-weather four-wheel-drive approach to the trailhead and a challenging most-of-the-day hike, tracing an old grade from prepark days and cairns to follow a wash. The wash is then the gateway to four superb galleries: High, Horseshoe Shelter, Alcove and Great. At the latter, chained tins hold binoculars and a log book of musings inspired by the mummylike figures with different garments, heads and eyes. Canyon volunteers may supervise viewing and point out detail.

Home of the Happy Camper®

40 YEARS AND GROWING!

Gerzeny's R.V. World has been serving Florida RV buyers since 1977 at its flagship location in Nokomis (between Sarasota and Venice), in Lakeland, and now in Bradenton. Look for a new R.V. World location in Fort Myers opening soon.

CLASS A

Gas & Diesel!



CLASS C

Mini Homes



CLASS B

Van Campers



CLASS B+

Specialty RVs



5TH WHEELS

& Toy Haulers



TRAILERS

& Extra Lights



FULL-SIZE RVS (CLASS A & C)



SMALL RVS (CLASS B & B+)



5TH WHEELS & TRAILERS



Note: Not all brands are available at all locations. Please call!



NOKOMIS

2110 N. Tamiami Trail
Nokomis, FL 34275
(941) 966-2182
Toll Free 1-800-262-2182

LAKELAND

940 Lakeland Park Ctr. Dr.
Lakeland, FL 33809
(863) 853-9177
Toll-free 1-877-663-7506

BRADENTON

6120 S.R. 64 East
Bradenton FL 34208
(941) 748-8889



FORT MYERS

5600 Enterprise Parkway
Fort Myers FL 33905

rvworldinc.com

Turn your RV into \$\$\$\$. Sell it. Consign it. Trade it. CALL ANY LOCATION AND ASK FOR THE CONSIGNMENT DEPT.

Native American perspective. Ranger interpretive programs often are held at the platform.

Taking the park's Scenic Drive (paved, then dirt) to the Capitol Gorge area, hikers can walk the wash trail to the Pioneer Register. Early on, the hike passes a handful of Indian petroglyphs, of which a rising sun is the best feature.

Graffiti has troubled the canyon. Signs announce recent culprits were

charged and sentenced, which raised a small cheer in me.

Farther along, an upper wall lists names, perfectly ruled and lettered, dated "Sept. 24, 1911." A log suggested this was a U.S. Geological Survey party. Entering the register, etched and axle-grease names record early travelers who dared the squeezed canyon in wagons and early vehicles. Noteworthy inscriptions date from the 1880s to 1930s.

Moab Area

Arches National Park

Courthouse Wash Panel, south of the park turnoff, holds a faint masterpiece that survived vandalism and a restoration of sandblasting. An interpretive board explains the preservation.

From U.S. Highway 191, north of Moab on the north side of the Colorado River Bridge, enter the parking area on the right and hike the gravelled path to cross Courthouse Wash and ascend to the base of the cliffs and the art. The pictograph panel measures 19 feet high by 52 feet long, with petroglyphs along the base. Etched into varnished rock are classic symbols and animals. The pictograph shows ghostlike Barrier-style figures with square shoulders, tapered bodies and horned or antennaed heads. Smaller figures float in their midst.

Inside the park, a short walk from the Delicate Arch/Wolfe Ranch parking area leads to the Wolfe Ranch rock art. Hike past the log cabin with the sagging roof and spur left off the Delicate Arch trail just past the bridged wash to reach the rock with the Ute hunting designs. This clean panel shows horses and dogs, as well as sheep, representing a more contemporary, familiar world.

Potash Road (UT 279)

Pursuing the Colorado River along the base of a decorated cliff wall, this highway attracts rock climbers and offers turnouts for viewing the extensive, exceptional rock art. At the entrance to the Poison Spider Mesa Trail (a Jeep area, where we ended the short drive), a rugged hiker trail ascends to three-toed dinosaur tracks, casts and raised impressions, and additional rock art, including superb wild-sheep panels.

For the easily accessed roadway art, turnouts and interpretive signs signal when to stop. The images are prolific and ironically preserved due to the roadbuilding, which removed the talus slope that elevated the original artists, distancing modern onlookers. Fremont, Barrier and Ute images — anthropomorphs, prehistoric paper

WALEX

Go green and clean.

WALEX BIO-PAK
NATURAL ENZYME DEODORIZER & WASTE BREAKER

Alpine Fresh
• Advanced Enzyme Formula Breaks Down & Controls Odor
• Free-Packaged Portion Control—No Spills!
• Rapid Breakdown of Waste & Paper
• Septic Tank Safe

Tropical Breeze
• Advanced Enzyme Formula Breaks Down & Controls Odor
• Free-Packaged Portion Control—No Spills!
• Rapid Breakdown of Waste & Paper
• Septic Tank Safe

Just Drop It In!

Just Drop It In!

The innovator in environmental portion control deodorizers. Natural enzymes rapidly break down waste and paper.

- **Safe for the Environment**
- **Breaks Down All Types of Toilet Paper**
- **Unbeatable Odor Control**
- **Biocide-free**
- **Alpine Fresh or Tropical Breeze**

MADE IN USA

AVAILABLE AT LEADING RV SUPPLY STORES

www.rvsanitation.com

Walex, Circle 145 on Reader Service Card



NEVER SETTLE.

When you buy a motorhome, we believe it shouldn't be a compromise. That's why Pursuit is one of the fastest-growing Class A's on the market. Built with Coachmen's 50 years of expertise, Pursuit's high-gloss Noble Select™ sidewalls with Azdel™ composite substrate are impervious to water and won't delaminate. And while other manufacturers build on the Ford F53 chassis, Pursuit uncompromisingly features an elongated wheelbase for a superior ride and better handling.

Visit CoachmenRV.com/Pursuit to find a dealer near you, or give us a call at (574) 825-8225.



Coachmen
a division of Forest River, Inc.

Pursuit
BY COACHMEN

Coachmen, Circle 113 on Reader Service Card

YOUR FIRST SOURCE FOR RV CHASSIS PERFORMANCE!



We Specialize in Diesel Pushers

• Trailing Arm Replacement Kits and Ride Enhancement Kits for Monaco, Roadmaster, Freightliner, Ford.

• Try us for all hard to find or out of production parts.

• Visit us at our

New Service Center in Coburg, OR

• Custom-tuned "Platinum Series" Shocks manufactured exclusively for SEI by Bilstein USA.



Charge Air Coolers



4 Bag Ride Enhancement Kits



Trailing Arm Kits

OEM DISTRIBUTOR FOR RADIATORS, CHARGE AIR COOLERS AND OIL COOLERS FOR MONACO, ROADMASTER, COUNTRY COACH AND WESTERN RV

541-343-0293
www.RV-CHASSIS.com

WRITTEN IN STONE



Clockwise from top: The visitor center at Capitol Reef National Park blends in to the red-rock backdrop. A variety of petroglyphs can be seen at Nine Mile Canyon's Daddy Canyon. Hikers are able to walk the wash trail in the Capitol Gorge area of Capitol Reef NP.



doll chains, hands and feet, spirals, circles and squares — crowd each lengthy panel and bend. The signature image is a giant bear being brought down by three archers at the bear's snout, back and front foot. Great herds stretch along the wall. Dot and line accountings likewise appear.



Newspaper Rock

This state historical monument, 12 miles from U.S. 191 on State Route 211/the entrance road to the Needles District of Canyonlands National Park, dazzles with its crowding and variety of etched images on black rock — a clear case of ancient typesetters gone wild. The 200-square-foot rock is jam-packed with abstracts and realistic representations: spiritual figures, bison, horseback riders, wheels, squiggles, deer, sheep and feet all tell an intricate tale.

Bluff Area

Sand Island BLM Recreation Area

Off U.S. Highway 163/191 southwest of Bluff, this recreation site along the San Juan River serves river users, dry campers and art-seekers. Go right upon entering to view the petroglyph wall, which is in the National Register

of Historic Places and includes images of Kokopelli, the popularized flutist and fertility symbol. Search for this repeating image among the many sheep, squiggly armed and antennaed beings, horses, dogs, frogs, snakes and geometric forms. **M**

For More Information

Bureau of Land Management

<https://www.blm.gov/utah>

Discover Moab

www.discovermoab.com/rockart.htm

National Park Service

www.nps.gov

Utah Office of Tourism

800-200-1160, www.visitutah.com

CONNECT TO Relaxation



THESE DEALS WON'T LAST!
HURRY IN TO SAVE THOUSANDS TODAY!



New 2018 Thor Motor Coach

FREEDOM ELITE 24HE

Island Lake, IL | List \$92,040 | **NOW \$66,999***

\$398 PER MO.*

Stk. #1403031 - Based on 10% down @ 4.99% APR for 240 mos.



New 2018 Thor Motor Coach

ACE 30.3

Chattanooga, TN | List \$122,100 | **NOW \$91,575***

\$543 PER MO.*

Stk. #1369596 - Based on 10% down @ 4.99% APR for 240 mos.



CAMPING WORLD RV SALES

877-CW-RV-SALE | CampingWorld.com/RV

*Government fees, state taxes, dealer fees and emissions testing charges as applicable will be added to comply with state vehicle codes. Freight and prep costs vary by state (Not applicable in CA, OH, TX, TN, GA, MS, LA, WA, OR or UT). Inventory and floorplans vary by location, not all advertised manufacturers available at participating dealers. New units will be delivered from the nearest authorized dealer. Contact your area dealer for availability. VIN numbers posted at dealership. All payments to qualified buyers with approved credit. Subject to lender terms. Down payment may be required (Not applicable in PA). RV must be purchased at a participating Camping World RV Sales Dealership to qualify. Offer is not retroactive on previous RV purchases. Benefits are subject to certain limitations and restrictions, and are subject to change. Discounts and benefits offered through your Good Sam Elite membership for 3 years from date of RV purchase. See dealer for full program details. Advertisements available at time of production. New unit photography for illustration purposes only. May not be combined with any other offer and not applicable to prior sales. Offers valid at any Camping World RV Sales or FreedomRoads dealer only. See dealer for details. © 2017 FreedomRoads, LLC. CAMPING WORLD and the CAMPING WORLD Mountain Logo are registered trademarks of CWI, Inc. and used with permission. Unauthorized use of any of CWI, Inc.'s trademarks is expressly prohibited. All rights reserved. Offers expire 7/7/17.

FRO29471-0417



VIRGINIA MOUNTAIN MAJESTY



Sparkling waterfalls, iconic mills and lively bluegrass music thrill the senses on the famed Blue Ridge Parkway

The Blue Ridge Parkway, nicknamed “America’s Favorite Drive,” is a 469-mile road that snakes along the crest of the Appalachian Mountains between North Carolina’s Great Smoky Mountains National Park at the south end and Virginia’s Shenandoah National Park at the north end. Noted as the longest scenic road in America that was planned as a single unit, construction began in 1935, just two years after President Roosevelt drove the Skyline Drive that traverses Shenandoah National Park, inspiring

him to connect these two great national parks with a scenic road.

The parkway’s sweeping turns and breathtaking views lure many motorhome travelers along its length. The northern half of the Blue Ridge Parkway, in Virginia, is RV-friendly, save for the Bluff Mountain tunnel at milepost 53.1, which may be a tight squeeze with a clearance of 13 feet 7 inches. On a recent road trip, my husband, Mark, and I used the parkway as a guide to cross Virginia from south to north. We hopped on and off frequently to enjoy not only the serene

beauty of the drive itself, but a wide variety of intriguing attractions nearby.

The Blue Ridge Parkway’s points of interest appear on maps by milepost numbers that decrease from south to north. The border between North Carolina and Virginia is at milepost 217. Our first stop after entering Virginia from the south was at the Blue Ridge Music Center, at milepost 213. We were absolutely charmed by this unique National Park Service offering which is both a museum and a music performance venue that celebrates the history of bluegrass music. When we stepped inside, we were surrounded by a fantastic collection of displays and plaques that explain the multicultural source of this colorful music.

Above: A motorhome drives past Mabry Mill at milepost 176. Inset, left: Fallingwater Cascades is an easy and rewarding hike at milepost 83. Inset, right: Deer sightings are common along the Blue Ridge Parkway.



We were fascinated to learn that the banjo has its origins in West Africa. Slaves shipped to America in the 1600s brought with them the knowledge and skills for making and playing the banjo. At the same time, immigrants from the British Isles brought their fiddles and love of ballads and dance music. These two musical traditions began to blend in the remote rural areas of the

Appalachian Mountains, and the roots of country music took hold. The advent of the phonograph and radio, and the ability to transmit music on the radio in the 1920s and 1930s, brought this unique sound to far-flung listeners, and a lively style of iconic American music was born.

Every afternoon during the summer, the Bluegrass Music Center presents a free four-hour-long concert in the breezeway attached to the museum. We were delighted by a pair of musicians, Scott Freeman and Willard Gayheart, who played one spirited duet after another on banjo and guitar. The audience was casually seated on folding chairs around them, and listeners came and went between songs on their way in and out of the museum.

Just a few miles from the Bluegrass Music Center, we discovered the small town of Galax, Virginia, which is the starting point for the 57-mile-long New River Trail, a flat and wide rails-to-trails bike path and state park that extends far into the

countryside. Winding along the edge of a river, we met families on bikes and walkers with dogs, all enjoying this lovely trail. Several walk-in and bike-in campgrounds are scattered along this bike path, and we were intrigued to see a few long-distance touring cyclists traveling on the New River Trail on bicycles loaded with bedrolls and sleeping bags as they traveled from campground to campground. After our ride, we found an ideal spot for a post-ride microbrew at Creek Bottom Brewing in Galax, which serves craft beers from all over the country. Their wood-fired pizza is truly out of this world, and enticed us back a second day.

Heading north again on the Blue Ridge Parkway to milepost 176, we came to beautiful Mabry Mill, a classic gristmill dating back to 1905. This historic building stands next to a pretty pond, and if you are there when the enormous rhododendron bushes are in bloom in the spring, you can get a fabulous photograph of the mill, framed by lavender flowers. We



Getting There

The parkway connects Shenandoah National Park, near Waynesboro, Virginia (milepost 0), with Great Smoky Mountains National Park, near Cherokee, North Carolina (milepost 469). There are entrances and exits at all major highways. In Virginia, interstates 64, 81 and 77 all have directions for accessing the parkway; the same is true for interstates 40 and 26 in North Carolina.

Photos: Emily and Mark Fagan



happily joined a small group of camera-wielding tourists to get a photo of our own, and later discovered that this is the most photographed spot on the Blue Ridge Parkway.

Inside the mill we saw a terrific demonstration of how paddle wheels were used to generate power a century ago. They were used not only to grind wheat and corn, but to operate enormous saws, drills and tongue-and-groove joiners as well. A long lever arm “brake” inside the building starts or stops the water flow over the paddle wheel outside. Once the wheel was rotating, huge interlocking gears inside the mill would begin to turn, generating the power to mash seeds on a grindstone or to move a saw blade back and forth. The ingenuity of this pre-electricity power plant tucked into the back hills of Virginia was astounding. Like gristmills all across the country, the man who built it essentially provided power to his neighbors, who brought grain and lumber to his mill for grinding and cutting.

Our minds still reeling as we left the immensely innovative yet achingly crude mechanical marvels

of yesteryear behind, we changed gears completely as we proceeded a few miles north on the Blue Ridge Parkway to the elegant Chateau Morrisette at milepost 172. Towering bushes of rhododendrons were bursting with color throughout the gracefully landscaped winery grounds, and it was easy to see why this is a favorite spot for weddings. They offered wine tastings in a grand tasting room, but their wines could be enjoyed even more when paired with a tasty meal in the restaurant overlooking the picturesque vineyard.

Our eyes and taste buds had been fully stimulated by the sights and flavors we’d been savoring along the parkway so far, but we had a hankering to engage our ears once again and listen to more of the musical sounds of Appalachia. In Floyd, Virginia, just off of Tuggle Gap at milepost 165, we found an incredible venue for witnessing and participating in free bluegrass music jam sessions.

The Floyd Country Store stands in the middle of the tiny town of Floyd, but somehow we missed it completely and walked right past, noticing only

Left: Driving under a green canopy on the Blue Ridge Parkway. Middle: Free bluegrass jam sessions delight at Floyd Country Store, where a sign declares “Loitering allowed.” Right: The scenic 57-mile-long New River Trail, a rails-to-trails bike path and state park, starts in Galax, Virginia.

that there were an awful lot of people hanging around on the sidewalk eating ice cream cones under a sign that said, “Loitering allowed.” When we reached the end of town without having found the store anywhere, we turned back only to discover that the crowd of ice cream cone eaters was standing right in front of it! As we soon learned, not only does this unique country store offer a fabulous place for people from far and wide to make music together out back, but it is a true old-time country store out front.

We wandered in, and just then the most magical sound filled the air as about 30 musicians sitting in a large circle at the back of the store spontaneously jumped into a rip-roaring tune. The jam session was completely impromptu, and there wasn’t a piece of sheet music to be seen anywhere. Banjos, guitars, fiddles, basses and dobros were everywhere, and the musicians were happily a-pickin’ and a-grinnin’ for all they were worth.

Between songs, a leader at the front would make a few jokes and then suggest another tune, and in a split second the group would be off and running again on another musical romp. Everyone seemed to know all the songs, and everyone throughout the store smiled broadly as the music enveloped us. In front of me, a little girl begged her mother to let her dance. There was barely room between all the violin cases and banjo cases stacked



With views of the Appalachians in every direction, summiting Marys Rock is a peak experience at Shenandoah National Park.

Pleasure-Way

Superior quality. Excellent customer service!



Plateau TS



Lexor TS



Ascent



Plateau FL



Plateau XLTD



Plateau XLMB

PLEASURE-WAY INDUSTRIES LTD. • WWW.PLEASUREWAY.COM

302 PORTAGE AVENUE, SASKATOON SK

800.364.0189

Pleasure Way, Circle 131 on Reader Service Card

in every nook and cranny of the floor, and the mom was a little hesitant, but suddenly an old lady from across the room came over and took the little girl's hands. To the delight of everyone watching, this pair of old and young danced quite a jig together. The charm for me was that neither the little girl nor the white-haired lady knew each other; they had just been moved to dance by the lively spirit of the music.

The Blue Ridge Parkway is an

undulating ribbon of road that winds up and down and around under a thick canopy of trees. The driving is peaceful, and the traffic is nonexistent [except, I hear, during the fall foliage season]. What surprised us, however, was that many of the scenic viewpoints had lost their expansive views because the trees have grown so tall and so dense since the parkway was constructed. Occasionally, we enjoyed spectacular vistas, but quite frequently



"YOU BOUGHT YOUR MOTORHOME TO GO ON ADVENTURES, NOT SO YOU COULD WORRY ABOUT MAKING IT UP HILLS." -GALE BANKS



Visiting national parks, touring famous landmarks, finding hidden treasures along the way, waking up to a new view everyday ... those are the reasons you travel. Don't let a lack of power and crappy mileage take the joy out of your trip; call us and let's talk about what we can do to breathe new life into your rig.

Product Benefits:

- More horsepower, torque and improved mileage
- Optimizes intake and exhaust airflow
- Helps keep your engine running better, longer



Banks PowerPack® for 2016-17 Ford 6.8L



Shop online: **bankspower.com**
or Call Now >> (800) GET POWER

WHERE TO STAY

There is no fee for admission to the Blue Ridge Parkway. Simply jump on or off wherever the road intersects with other highways and byways. The National Park Service offers several dry-camping campgrounds with RV sites on the Blue Ridge Parkway for \$20 per night. Visit <http://www.nps.gov/blri/planyourvisit/camping.htm> for more information.

There are also RV parks with full hookups within a modest drive of the parkway:

Near Galax, New River Trail and Blue Ridge Music Center
Fancy Gap/Blue Ridge Parkway KOA, 276-728-7776, <http://koa.com/campgrounds/fancy-gap/>

Near Floyd
Chantilly Farm, 540-808-4984, <http://chantillyfarm.com/wp/camping>

Near Apple Orchard Falls and Fallingwater Cascades
Yogi Bear's Jellystone Park, 540-291-2727, www.campnbr.com
Natural Bridge/Lexington KOA, 540-291-2770, www.naturalbridgekoa.com

Near Shenandoah National Park:
Yogi Bear's Jellystone Park, 540-743-4002, <http://campluray.com>

For a comprehensive list of RV parks, visit <http://www.blueridgeparkway.org/v.php?pg=142>

we would stop at a scenic overlook only to find there was nothing to see! Often, we found it was more interesting to travel the secondary roads that run nearby the Blue Ridge Parkway, as they revealed the flavor of the people, their heritage and their interests.

If the wide-open views we'd anticipated weren't always visible, the sparkling waterfalls that we found tucked into the thick forest vegetation of these mountains turned out to be truly stunning to behold, and each was utterly unique. At milepost 83 we found Fallingwater Cascades, a fairly easy hike to a broad waterfall that tumbled over the rocks under branches laden with pink rhododendrons.

As easy as Fallingwater Cascades was to hike, the Apple Orchard Falls waterfall at milepost 78 was strenuous. Because of the vertical nature of waterfalls, many waterfall hikes along the Blue Ridge Parkway are steep climbs up and down between the top of the falls and the bottom. The Apple Orchard Falls hike starts on a



Motorhome Chassis Performance

Make the Journey as Great as the Destination

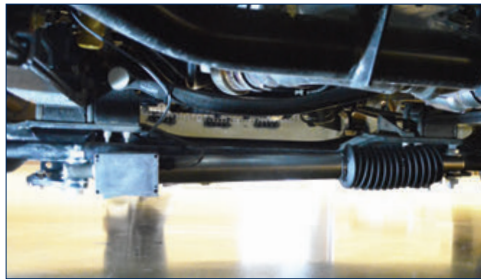

Trucenter™

Stop fighting the steering wheel.

- Reduces driver fatigue
- Prolongs the life of tires and chassis
- Adjust for road crowns and high winds with the touch of a button
- Retains control in case of a blowout

"This trip we had a rear Blue Ox Trac Bar and a rear Blue Ox Sway Bar installed. While being passed by trucks we are no longer jolted or pushed around. We now look forward to hitting the road."

-Leo Sharpe



Trac Bars

Enjoy a more controlled ride.

- Eliminates constant steering corrections
- Improves handling while towing
- No fish tailing
- Prolongs tire life



Sway Bars

Improve the drivability of an RV.

- Minimizes top heavy feeling
- Improved control and performance during quick maneuvers

Have an Adventure

blueox.com • 800-228-9289

Blue Ox, Circle 102 on Reader Service Card

high ridge and descends rapidly toward the falls, making the first half of the hike deceptively easy. The return trip was a serious workout, but the magnificent falls were well worth the effort.

The Apple Orchard Falls trail intersects with the Appalachian Trail, a nearly 2,200-mile-long hike that traverses the eastern states from Springer Mountain in Georgia to Mt. Katahdin in Maine. Lots of people hike the whole Appalachian Trail each summer, and we were floored when we met a young man at the intersection of the two trails and found out he was six weeks into his four-month-long journey and had covered 770 miles of the Appalachian Trail so far. He was carrying a very small pack on his back for such a big adventure, and he told us he had already worn out one pair of hiking shoes!

A little further north, just 2 miles from Tye River Gap at milepost 27, we found Virginia's tallest waterfall: Crabtree Falls. This hike also proved

to be a serious stair-stepping workout, as the trail alternated between a pleasant uphill walk through the woods and actual staircases that were built to traverse the most sheer sections. The sound of water crashing down the mountainside grew and faded as the trail ascended many switchbacks that led toward and away from the falls, and we had to laugh each time we turned a corner and faced another tall staircase. Each portion of the falls was wonderful, however, and the views and rhododendrons at the top were a great reward.

The northernmost part of the Blue Ridge Parkway morphs into Skyline Drive, which wanders the length of Shenandoah National Park. A glorious hike down to the base of Dark Hollow Falls followed by a hike into the sky to reach the summit of Marys Rock were two highlights in Shenandoah that capped off our road trip through Virginia.

Following the trail of the Blue Ridge Parkway had taken us to some memorable places, but like all

first-time travelers on this unique American road, we had sampled just a few of the many treats that await sightseers there. We look forward to exploring the area in much more depth in the future. **M**

For More Information

Blue Ridge Parkway

828-348-3400, www.nps.gov/blri

Blue Ridge Parkway Virginia Experiences by Milepost

www.blueridgeparkway.org/v.php?pg=823

Blue Ridge Music Center

276-236-5309, www.blueridgemusiccenter.org

Chateau Morrisette Restaurant

540-593-3647, www.thedogs.com

Floyd Country Store

540-745-4563, www.floydcountrystore.com

Mabry Mill Restaurant & Gift Shop

276-952-2947, www.mabrymillrestaurant.com/history/

New River Trail State Park

276-699-6778, www.dcr.virginia.gov/state-parks/new-river-trail



KING® Tailgater®
d'ish

KING Quest™
DIRECTV

Portable Or Roof-Mounted Satellite TV Antennas

These fully-automatic antennas give you the freedom to take your favorite DISH® or DIRECTV® programming with you RVing, to the great outdoors or anywhere in between.

KING Tailgater, **VQ4500**

KING Quest, **VQ4100**

*For DISH HD & SD programming. Works with DISH pay-as-you-go programming or simply add to your existing home service.
**For models VQ4100, VQ4200, VQ4400 & VQ4500 only.
DISH® and Tailgater® are registered trademarks of DISH Network L.L.C.
DIRECTV® is a registered trademark of AT&T Intellectual Property.

**KING ACCESSORIES
PORTABILITY & PROTECTION**



Tripod Mount

Keep your KING antenna** off the ground and protected with this custom, adjustable tripod. Includes leg anchors for stability and a convenient carry bag. Tripod Mount, **TR1000**



Quick Release Roof Mount

Turn your KING antenna** into a roof-mounted system and then into a portable antenna in seconds! Trees blocking your signal? No problem! Just dismount your KING antenna, then reposition anywhere to get a better view of the sky and you'll be watching your favorite program in minutes.

Quick Release Roof Mount, **MB700**

KING kingconnect.com
Simply better, by design.™

Inside and out, **BETTER BY DESIGN**



PLATINUM

Ford
Class B+

PLATINUM II

Mercedes
Class B+

Arriva

Mercedes
Class B



Coach House has been manufacturing luxury downsized motorhomes in Venice, Fla., since 1985, earning the highest accolades not only from the RV industry and press, but from customers as well.

This family-owned company builds small, fuel-efficient RVs ranging from 23 feet to 27 feet, using either the Ford E-450 or Mercedes Sprinter chassis.

Coach House was founded with one fundamental goal: to build the best RVs in the industry. That quest led us to develop a patented one-piece hand-laid

“The quietest motorhome I’ve ever driven.”

— *The RV Doctor, FMCA*

fiberglass body that is reinforced with carbon-fiber. This makes for a very durable RV that is less likely to leak, squeak or rattle over time.

Beyond the unique one-piece shell, here are some of the other factors that make the downsized Platinum and Platinum II your best motorhome value:

- More standard features than any other motorhome in their class.
- Professionally decorated interiors with solid-surface countertops, porcelain toilets, name-brand appliances, 32-inch HDTV, and more.
- Choice of chassis: Ford E-450 (gas) or Mercedes Sprinter (diesel).
- Nationwide warranty service.
- High ratings for ride and safety.



BUY FACTORY-DIRECT AND SAVE!

Coach House motorhomes are sold direct from the factory — there is no middleman. The “Coach House Buying Experience” includes: personal attention from courteous employees; a generous trade-in allowance for your current RV; on-the-spot financing (for qualified buyers); and instruction in how to operate your new RV.



VISIT THE COACH HOUSE PLANT

See for yourself what makes a Coach House motorhome so special. Visit our factory at I-75 exit 195 near Venice, Fla., where a knowledgeable salesperson can show you the latest Coach House models on display in our showroom. The showroom is open from 9 a.m. to 5 p.m. Monday–Friday or by appointment.



COACH HOUSE, INC. · 3480 TECHNOLOGY DRIVE · NOKOMIS, FL 34275 (941) 485-0984

TOLL-FREE AT 1-800-235-0984 · ONLINE AT CoachHouseRV.com

OPEN A GOOD SAM | CAMPING WORLD VISA® CREDIT CARD ACCOUNT TODAY TO EARN UP TO



GET ON THE ROAD TO **BIGGER REWARDS!**



2,000 BONUS POINTS

the first time you use your card for a purchase
(up to \$25 value)

DOUBLE POINTS

on purchases outside Camping World & Good Sam for
the first 90 days (up to 2,000 points/\$25 value)

REDEEM

points for cash back as a statement credit, Good Sam
memberships, restaurant, retail and gas gift cards,
plus, MUCH more!

FOR EVERY \$1 SPENT



POINTS at **Camping World** and on
Good Sam purchases



POINTS on **gas** & at **private campgrounds**
in the U.S. & Canada²



POINT **everywhere else** VISA® is accepted

VISIT A CAMPING WORLD SUPERCENTER NEAR YOU!

NOT NEAR A STORE? CALL: 1-844-271-2591 CLICK: CampingWorld.com/GoodSamVisa
TDD/TTY 1-888-819-1918

¹Offer subject to credit approval. Cardholders will earn five (5) points for every one dollar (\$1.00) of Net Purchases spent on Good Sam Club related products and services made on their Account rounded to the nearest dollar. "Good Sam Club eligible purchases," are defined as products and services purchased from Good Sam Enterprises, LLC and its affiliates and partners, including but not limited to the following: Coast to Coast, Camping World, Good Sam, TL Enterprises, and NGIC. Cardholders will earn three (3) points for every one dollar (\$1.00) of Net Purchases made at any gas station and any retail establishments that classify their merchant location to Visa as Campgrounds and Trailer Parks within the U.S. and Canada. For all other purchases made anywhere else, Cardholders will earn one (1) point for every one dollar (\$1.00) of Net Purchases made on their Account rounded to the nearest dollar. A one-time bonus award of (2,000) Rec Rewards Points will be awarded to new cardholders after the first purchase is posted to the Account. Bonus Rec Rewards Points will be posted approximately 30 days after the initial qualifying transaction. Cardholders will earn double points (up to 2,000 bonus points total) on all purchases made outside Good Sam or Camping World within the first 90 days of account opening. This rewards program is provided by Comenity Capital Bank and its terms may discontinue or change at any time. For information about the rates, fees, other costs, and the reward program rules (including point accrual rate, bonus point awards, etc.) and benefits associated with the use of this credit card program please visit <http://www.comenity.net/goodsamcampingworld> for complete terms and conditions. © 2016 CWI, Inc. & Good Sam Enterprises, LLC. CAMPING WORLD and the CAMPING WORLD Mountain Logo are registered trademarks of CWI, Inc. GOOD SAM and the GOOD SAM ICON are registered trademarks of Good Sam Enterprises, LLC. Unauthorized use of any trademarks is expressly prohibited. All rights reserved.

²Each merchant is assigned a code by a third party that indicates the merchant's area of business. Bonus points will only be awarded if the merchant code for the purchase matches a category eligible for the offer. Comenity Capital Bank does not have the ability to control assignment of merchant codes.

The Good Sam | Camping World Visa® and Good Sam | Camping World Visa Signature® cards are issued by Comenity Capital Bank, pursuant to license from Visa® U.S.A. Inc.

GCR51991 - 1216

WORK CAMPING

BECOMING A PARK HOST IS A
UNIQUE WAY TO SEE THE COUNTRY

A quiet, wooded area by a lake; a dry, dusty spot in the desert; a bustling park in the middle of town. What do these have in common? They are all locations that offer park-host positions, and becoming a host can be a great way to utilize your motorhome.

There are many different choices for park hosts, from campgrounds and day-use parks to seasonal parks. Most people do not understand the differences between these options or what the host position even entails. Popular with couples and retirees, park-host positions are a unique way to visit different areas while having an affordable place to stay.

My husband, Andy, and I are full-time RVers. In 2015, we sold our home in Minnesota, bought a motorhome, quit our steady jobs and set out on an adventure. We wanted to change the path our lives were on, to find some way that allowed us to work less and travel more. So we decided to downsize and simplify our lives.

We had been traveling the western United States for a few months, staying in various campsites along the way. After battling snow and rain, and the challenges of finding our next spot, we finally reached California. The salty sea breeze touched my



Angela sits behind the wheel of a John Deere Gator, a vehicle commonly used in many parks.



skin and I looked across the campsite at my husband and said, "I think I'd like to stay here for a while."

Left: The McLaughlins' 1997 National RV Dolphin and 1988 Jeep Wrangler easily fit in the host site. Be sure to research whether a potential site is large enough to accommodate your needs. **Right:** Park hosts are often responsible for cleaning trash around the facilities.

So, What Is a Park Host?

With visitors traveling in and out of areas on a regular basis, many campgrounds and parks find the need for a park host almost a necessity. After staying in campgrounds across the country, seeing hosts with a variety of setups, we decided it looked like a pretty good gig, but we wanted to check it out for ourselves.

Most park-host positions are unpaid volunteer positions — though some private companies pay wages. In exchange for a set number of hours or shifts, hosts often receive a free place to park their RV, plus typically offer water, sewer and electric services, free of charge.

Parks may ask for a specific time commitment, whether seasonally or

long-term. Some ask for as little as a two-week minimum, while others may request at least three months. Parks that require hosts year-round may ask for a minimum of a six-month commitment. There are extended-stay options, where a host will be stationed in a location for several years, and emergency fill-in situations, where a person may be placed as an

interim host for a short period of time.

We have met hosts who spend half of the year in one state and then travel to another host spot for the second half of the year. Doing this is a great way to chase nice weather and favorite seasons.

Where Can I Find a Host?

National parks, national forests, state parks, the Bureau of Land Management, RV parks and private campgrounds are some of the most common places to find host positions. Lesser-known options include opportunities through a county or city.

Many of these may be found online, and you can typically apply for them online as well. If interested in a specific state, visit the state park or state forest website. Other common options include searching www.fs.fed.us or www.nps.gov for available host positions.

How Do I Become a Host?

The interview and selection process will differ from place to place, with each park being unique. It is best to do your research before committing to an area or park.

We applied to state, county and federal campgrounds in California. Since both of us were retail managers in the past, we knew the value of good help and, since we were healthy and willing to work, we felt we had a lot to offer.

We were camping in a beautiful campground named Guajome Regional Park in Oceanside, California, crossing our fingers as we awaited a response. Thankfully, the County of San Diego contacted us very quickly. We were told there were three parks with open host positions — so we set out to check them out.

What Will the Site Be Like?

Host sites vary from park to park. There are spots that look identical to

the other campsites, with just a sign out front to designate that person as a host. Some sites have fenced yards, gardens and sheds. Even in campgrounds without utilities available for overnight sites, the host site will typically include these amenities. Set up with their strings of colorful lights, comfortable chairs and even chicken coops, some seem to have settled in nicely, making their space as much a home as possible.

After looking into the park options given to us, we quickly crossed one of them off the list because it was a very temporary position. Agua Caliente is a desert park that closes during the summer months due to the high temperatures. The other two parks posed more of a debate. Dos Picos County Park was a gorgeous campground set in the foothills, complete with hiking trails and an abundance of nature.

The other was a community day-use park in town named Collier County Park. We had originally imagined being campground hosts and enjoying the seclusion that would bring us. However, the conveniences of living in town were very tempting.

Being in a community park meant living in a neighborhood. The site was fully fenced with a cement pad and wood shelter overhead. Water, sewer and electric hookups were available — as they also were in the campground — but there was also the possibility



Left: We love the views around Collier County Park, especially this one from the rear gardens area. Right: Angela's husband, Andy, trims a pepper tree. Landscape maintenance is another daily task for a park host.



Boosting Your

Smoothtalker®
Cell Signal
Anywhere

THE MOST POWERFUL
CELLULAR SIGNAL
BOOSTERS AVAILABLE

STAY CONNECTED
WHEREVER YOU GO

BOOSTS 3G, 4G LTE
For Mobile and
Fixed Locations



Multiple Users
Multiple Devices



Extends Cellular
Coverage



Increase Data Speeds
up to 30 times



Reduces Dropped
Calls

Now Available in stores
and online at



CAMPING WORLD



Smoothtalker®

Cellular Signal Boosters
Boosting Your Signal Anywhere



Automatic power
control protects the
Cellular Network



Far left: Day-use parks are popular places for families to hang out on the weekends, or for kids to play after school. Left: Some park-host sites are fenced and covered, which allows for more privacy.

of having cable and internet there. In addition to this were the advantages of being within walking or biking distance to grocery stores and potential jobs.

As we travel in a 34-foot Dolphin motorhome towing a Jeep, that leaves us with only one vehicle for day-to-day transportation. We decided to try out the day-use park since it appeared to be the best choice for us.

Day-use host living is different from campground host living. In a day-use park, there is no overnight camping and the park closes at sunset. They are typically community parks where children play after school, families picnic on the weekends, and groups hold large events. They may have multiple reservation areas for the purpose of entertainment. The only people who stay on-site overnight are the hosts.

What Are Your Responsibilities?

After going through several interviews, health exams and background checks, we were able to move our motorhome into its new spot. After the application process, many parks require at least one interview and a criminal background check to make sure the person(s) chosen for the location is a good fit. A health exam may also

be required to determine that all of the necessary tasks can be safely completed.

Have you ever wondered who gets the job of cleaning park restrooms? Well, that's us. Common tasks for park hosts include cleaning up and taking out trash and recycling around the park; mowing lawns; gardening; cleaning debris; and the lovely job of cleaning the restrooms. Depending upon the park, some hosts will also assist with checking guests in and out, as well as cleaning up RV, camping and picnic areas once guests depart.

Park hosts also act as the eyes and ears of the facility, maintaining the security and identifying potential issues when paid employees are not on-site. The presence of a host often minimizes vandalism and offers a sense of safety for the guests. Friendliness and flexibility are key traits for a host, who will interact with park visitors whenever needed. Maintaining a friendly presence is an important part of being a host, with interactions ranging from guests looking for more information about the area to those who run into problems while on the property.

What's the Schedule Like?

As volunteers, we are scheduled for 20 hours a week over four specific days.

Andy and I split our hours between the two of us and are scheduled for specific shifts that occasionally change to fit the needs of the park. We share the work at our park with two attendants and are supervised by park rangers.

Most of our time is spent picking up trash around the park. We have our set of daily tools: a John Deere Gator, a pick-stick, a bucket, gloves and trash bags. We also assist with maintaining walking paths, pruning plants, pulling weeds and trimming trees, mowing lawns, helping park guests, cleaning facilities, maintaining the security of the park, locking the gates and bathrooms at night and unlocking in the morning, light maintenance, as well as other tasks that arise.

Is it Worth It?

Becoming park hosts has been a rewarding experience, providing us a chance to learn more about this unique way of traveling. We see our regulars pass us by, with a smile and a nod as they walk their dogs down the paths. People approach us as we clean up, thanking us for making the park a nice place to visit. Looking out across the field, watching kids play soccer and listening to the laughter of people in the park, we feel pride and satisfaction in our volunteer work. If you are someone who likes people, loves the outdoors, and is not afraid to get your hands dirty, being a park host might be the right fit for you, too! **M**

Follow us on our journey at www.thewanderingdolphin.com.

SOCAL DREAMING?

Volunteer opportunities, like park host, are available year-round. If you're in the Southern California area, contact volunteer coordinator Cheryl Wegner to learn more at cheryl.wegner@sdcounty.ca.gov or 858-966-1335, or visit the County of San Diego Parks and Recreation website at www.sdparks.org.



Savings can take you to
amazing sights.



GEICO® *for your RV*

geico.com | 1-877-434-2678 | Local Office

Geico, Circle 117 on Reader Service Card

Some discounts, coverages, payment plans and features are not available in all states or all GEICO companies. GEICO is a registered service mark of Government Employees Insurance Company, Washington, D.C. 20076; a Berkshire Hathaway Inc. subsidiary. © 2017 GEICO



MOTORHOME NOMENCLATURE

Whether it's a Class A, B or C, we take the confusion out of motorhome categories

Classes of motorhomes sometimes create confusion, especially to those new to RVing. Even those with RV experience can, at times, get the classes mixed up when changing from one type of motorhome to another.

The type of motorhome is directly related to the chassis, and this point confuses people the most. While there are three classes of motorhomes in the RV industry, they are laid out differently, and detailed in the National Fire Protection Association standard 1192, which governs the design and construction of recreational vehicles.



Class A motorhomes are built on a stripped motor vehicle chassis, for the most part. The exception to this are conversion coaches, which are built using specially designed bus shells, like those from Prevost and MCI, or have been built from the ground up using a monocoque design

like the Newell.

Class A's are motorhomes anywhere from 22 feet to 45 feet, and can weigh from 18,000 pounds to more than 50,000 pounds. Most modern Class A's have permanent sleeping for at least two (a queen or king bed) and have convertible sleeping spaces like a dinette or couch that fold out, although models with bunk beds are becoming more popular. These motorhomes are equipped with either gasoline or diesel fuel engines. Some newer models, such as the Winnebago Via, are built on the Mercedes-Benz

Sprinter chassis, which affords better fuel economy because of its smaller size. Most Class A motorhomes have one to four slideouts. All Class A's are self-contained.

Pros: Class A motorhomes are usually the most comfortable, and tend to be more luxurious (though basic models are available). The ability to have easy access to the bathroom, galley and bedroom while on the road is a huge benefit. Class A's also usually have the most storage, many with full basement compartments.

Cons: Larger lengths can be difficult to park in public campgrounds and are not conducive to traveling in congested areas; it's best to tow a dinghy vehicle or rent a car once at the destination. They may have a smaller sleeping capacity than some other types of RVs.

Class B motorhomes are generally the smallest, and probably the costliest per square foot. They are built within an automotive-designed and built van. The van's original sides and rear doors are maintained, and the interior features are compact and built within those confines. Most of these Euro-sourced vans can be factory ordered with a raised roof for additional headroom and interior space.

Practical for touring, these motorhomes include most of the amenities, but in a compact space. Sleeping accommodations are normally designed for two, and while extra room for another occupant may be available, the fit will be snug, which is a reasonable compromise for a rig this size. Class B's tend to be relatively expensive, but are often well-built. Like the other types of motorhomes, these are available using the European platforms, which afford greater fuel economy, as well as modern styling.



The Class B motorhome is generally built within the confines of a standard panel van, but frequently with a raised roof for additional headroom.

Pros: Class B's are easy to drive and park. They can be used as a second personal vehicle at home if needed. They require little storage space at home, and can even fit in a large garage or barn.

Cons: Class B's can be quite small, and are best suited for touring or shorter visits in an RV park. They're also pretty expensive, costing as much or more than many entry-level Class A's or C's.



Class C motorhomes are popular because of their size, economy, ease of driving and family-friendly features. Class C motorhomes are built on a cutaway chassis, which retains the front cab of a van or truck. From the cab rearward, the chassis is stripped, providing a platform for the motorhome body.

Class C's are mid-sized and sometimes called "mini-motorhomes." Many of these have

a cabover bed or entertainment system. Class C's have all the amenities RVers are looking for, and can be spartan or deluxe. Some have full basement storage, and all are self-contained.

Class C models are also built on larger medium-duty chassis, like those from Freightliner or International. Many people assume Class C's are smaller and easier to drive but in many cases their length

Class C motorhomes can be small and economical, or as large as a Class A, like this Super C motorhome. The key to the designation is that they're built on a cutaway chassis.

and height rival Class A's. Class C models built on the Mercedes-Benz Sprinter, RAM ProMaster or Ford Transit chassis are more compact, but have all the amenities that make this class of motorhomes so versatile.

Pros: Often, Class C's can sleep up to eight or more people, making them family-friendly. The living area is accessible from the driver and passenger seats; cockpit doors are also convenient.

Cons: Less square footage than Class A's, and there's usually only one slide room, but sometimes two. Gross vehicle weight ratings (GVWR) are limited on some models, so cargo carrying capacities should be considered before making a purchase.



Whether gas powered (far left) or diesel pusher (left), Class A motorhomes are built on a stripped chassis, and the coach is built from the basement up.

Class A Chassis

The stripped chassis, in its original form, which resembles a tractor, is a vehicle without the body. These come in numerous configurations for builders to work with, including gas-powered chassis (currently only available from Ford) and diesel chassis, available from Freightliner and Spartan Chassis. A few motorhome builders offer proprietary platforms, using components from the major chassis manufacturers.

Once the chassis is driven into the plant, the motorhome builder welds up the foundation platform or saddle frame to the chassis, which becomes the basement compartments and floor deck.

1970s or 1980s, only a lot fancier.

The motorhome manufacturer orders the van with specific features based on its needs, and then builds it out from there. Sometimes the roof of the van is cut off and a fiberglass raised-roof assembly is attached; however, many current vans have selectable roof heights available from the factory, thereby eliminating this requirement.

Class C Chassis

On a Class C, the van or truck cab is the only body on the chassis, and the rear wall is missing. The rest is a stripped chassis. The motorhome manufacturer then builds out the saddle frame and adds the body. There are a number of cutaway chassis manufacturers out there, and these chassis are commonly used for moving vans, ambulances and other specialty vehicles.

Knowing the nomenclature of the motorhome will help you narrow down your search. But, the most important thing to remember is that regardless of the motorhome class, if it feels good, serves your needs and puts a smile on your face, then that's the right motorhome for you. **M**



Class B Chassis

A Class B platform is an empty panel van that's completely modified into a motorhome. Imagine a conversion van from the



Left: The Class B motorhome is often built on newer Euro-styled vans, like this Ford Transit. Several different roof heights are available from the OEM. Above: The van cutaway chassis features the van cab up front, but a stripped chassis behind.

THE B+ MYTH

Some motorhome manufacturers and sellers over the years have created the Class B+ category. This nomenclature is typically used to attract a Class B motorhome buyer looking for a larger unit but not needing the full cabover section.

Officially, there is no such thing as a Class B+ motorhome. If the motorhome is built on a van-cutaway chassis, then it's a Class C. If it's built within the confines of a production automotive van, then it's a Class B.



Explore with Wonder

Built on the new Ford Transit chassis, the all-new Wonder is filled with smarter space solutions that combine superior design with innovative functionality. From the residential queen-size Murphy Bed to an abundance of interior and exterior storage, every inch is utilized to its maximum potential in the Wonder, allowing you the freedom to go wherever your “wonders” may lead you. Explore the all-new Wonder and the rest of LTV’s award winning lineup at:

LEISUREVANS.COM



LEISURE
TRAVEL VANS

Leisure Travel Vans, Circle 143 on Reader Service Card



LOWEST PRICE

PowerFlush Technology Completely Washes Bowl with Every Flush!

CLUB MEMBERS
Save
\$65



CLUB SALE
\$175

NOW WITH
SLOW-CLOSE
WOODEN LID
AND SEAT!

Dometic® 310 Series Gravity Discharge Toilets,
High Profile, 18" H

White #107004 Bone #107005

Full-size, lightweight 100% ceramic bowl. Mfr. 2 year warranty.
Reg. \$240 | Let Us Install It—Club SALE \$150 | 🚚

↔️ **DOMETIC**



CLUB MEMBERS
Save
45%

CLUB SALE

Only 75¢ ea.

Enviro-Soft 2-Ply Toilet Paper #49444
500 sheets per roll. | Reg. \$1.45 ea.

Limit 8 rolls per customer. Offer valid only at retail SuperCenters.

Offers 15% MORE storage space in the same footprint!

CLUB MEMBERS
Save
\$240



CLUB SALE
\$1179

New Generation Refrigerator

7 cu. ft. #34424

Offers more food storage when replacing 6 cu. ft. models.

53 3/4" x 23 1/2" x 24". | Reg. \$1419.99

Let Us Install It—Club SALE \$246 | 🚚

Direct Ship | ♥

Fits any 14" x 14" roof vent



CLUB MEMBERS
Save
35%

CLUB SALE
\$46.97

Allows 95%-100% airflow for better air exchange

Dometic Ultra Breeze™ Vent Covers

White #58894 Black (not shown) #58895 ♦

NEW COLOR! Gray (not shown) #86349

Protects your RV interior against unexpected showers. | Reg. \$72.99

Let Us Install It—Club SALE \$16

♦Catalog & Internet Only



CLUB MEMBERS
Save
25%

CLUB SALE
\$93.97

Veranda Shade™

4 1/2' x 10' ♦

Coffee #71140 Burgundy #71139 Blue #71190

Reg. \$126 | ♦Catalog & Internet Only

4 1/2' x 15'

Coffee #6072 Burgundy #6070 Blue #6067

Club SALE \$99.97 Reg. \$134 | 🚚

Burgundy

Blue

ALL NEW EXPANDED PET & HOUSEWARES DEPARTMENTS!
OVER 2,000 NEW ITEMS IN STORE OR ONLINE!



S OF THE SEASON!



PRICES GOOD THROUGH 7/9/17



CLUB MEMBERS
Save
40%

**WHILE
SUPPLIES
LAST!**

CLUB SALE
\$19⁹⁷ 100 lb. capacity

Bungee Table, 2-Pack #89632
Stands 16⁵/₁₆" L x 16⁵/₁₆" W x
20⁷/₁₆" H open, folds to 2" H.
Reg. \$33.99



All chairs fold for
easy transport
and storage

CLUB SALE
\$47⁹⁷

A. **NEW!** Sling Chair #96662
Reg. \$63.99 | 🚚 | ❤️

B. **NEW!** Directors Bag Chair #96663
Club SALE \$34.97 Reg. \$49.99
🚚 | ❤️

C. Directors Rocker #96664
Club SALE \$38.97 Reg. \$51.99
🚚 | ❤️

CLUB MEMBERS
Save
up to
30%



CLUB MEMBERS
Save
\$120

CLUB SALE
\$179

Produces up to 33 lbs.
of ice per day!

Ice Maker & Water Dispenser #91423
Dispenses both ice and water from one
convenient tabletop unit. 120 volts, ETL listed.
16¹/₂" H x 14" W x 18" D. | Reg. \$299.99 | 🚚 | ❤️



CLUB MEMBERS
Save
35%

CLUB SALE
\$21⁹⁷

D. Rubber Roof Cleaner, Gallon #13746
Rubber Roof Cleaner dissolves dirt and roof
residue that cause ugly grey streaks. Blocks UV
and reduces maintenance up to 75%. | Reg. \$34.99

E. Rubber Roof Treatment, Gallon #13745
Club SALE \$25.97 Reg. \$39.99



CLUB MEMBERS
Save
35%

CLUB SALE
2 for \$19⁹⁷

9"H Step Stool
Black #27647 Beige #67052 Red #96641
Folds to 1¹/₂" D. | Reg. \$16.29 ea.



Supports
up to 300 lbs.

JUNE 22-25 ★ ★ ★

**SALUTE to
SUMMER**

★ ★ ★ **WEEKEND**
SUPERCENTERS NATIONWIDE



CLUB MEMBERS
Save **40%**
up to
ON 4-DAY ONLY SPECIALS!

PLUS,
**FREE
SUNGLASSES**



WITH PURCHASE OF \$75 OR MORE!
WHILE SUPPLIES LAST!

**FREE
LUNCH!**

FRIDAY, JUNE 23rd &
SATURDAY, JUNE 24th ONLY
11 am to 1 pm

CW029590



The Road to Freedom

Thor's Freedom Elite 23H Class C offers great storage capacity, quality amenities and plenty of comfort for a party of one or a family with kids **By Donya Carlson**

It was one of those days — no, more like one of those weeks — where chaos ruled and one thing after another seemed to go askew. That overly dramatized Calgon bath products commercial from the 1970s and '80s — “Calgon, take me away!” — played in my head. Just when I thought I may go into hiding, Tech Editor Chris Dougherty rang me up to ask if I was interested in taking off for a few days to review a Class C Freedom Elite. (I swear he's a mind reader.) OK! And how apropos that the name includes “freedom” because that was precisely what I needed.

Based on the Ford E-Series chassis, the Freedom Elite line is manufactured by Thor and is offered in five floorplans ranging from 24 feet to a 32-foot-2-inch bunkhouse model with two slides. We tested the 23H, the second smallest of the Elite line, measuring 24 feet 10 inches, with no slides.

Before we launch into the living area of the 23H, let's look at outside storage. This aspect drew high marks from me,

since it was the starting point when packing for an outing to a full-hookup RV park where I had a few days to myself before my husband, Bill, joined me for a few more. At the rear of the 23H, a large compartment can be accessed through two exterior doors — one from the curbside and one from the back. Inside is an included 4-by-2-foot portable table — a feature that is exclusive to the 23H — in its own cubby. With big doors held out of the way with clips, it was easy for us to work together to load two mountain bikes. Though there wasn't a lack of space, we removed the bicycles' front tires and placed them into the larger of two bins with lids that occupy the space beneath the floor of the compartment. The storage compartment has several bright lights, and families with kids will appreciate the space to load in even more gear.

Though floor space inside the RV may be a little tight for those with multiple kids, a roomy dinette with vinyl benches comfortably seats four, plus a cloth-covered barrel chair

ABOVE: The Freedom Elite 23H was great for our trip to the desert, and also to view a spectacular sunset over California's Santa Monica Mountains.

Top right: Large windows add an open feel, and a privacy shade closes the bed off from the galley. The end of the bed is cut at an angle to allow wide entry into the bathroom. Middle right: The efficient kitchen has a microwave and oven, plus continuous grates over the three-burner range, and also the counter extension to the left of the range, and also the great interior lighting.

across from the dinette is perfect for the weary lady or man of the house to lounge in. A 40-inch LED TV is located on a manual swivel that lies flat against the passenger-side cabover wall when not in use. The TV is supplemented with a Sony DVD player that is housed in an adjacent cabinet. Swing the TV out and it's visible from pretty much anywhere in the RV — including the bathroom, if you're so inclined.

Kids of any age can climb up to a spacious 54-by-96-inch cabover bunk via a sturdy ladder. The ceiling tapers off where the front cap curves downward, so some headroom is lost. Two cup-holders are up against the front wall and a narrow ledge runs the length of the bunk for kids to park (and race) Hot Wheels and display small stuffed animals. For additional sleeping space, the dinette table folds down into a bed.

The "bedroom," which shares a wall with the bathroom and has a queen mattress cut at an angle at one end for easier access to the bathroom, can be closed off with a privacy shade. Three large overhead cabinets offer voluminous storage space, though you'll have to kneel on the bed to get to them. With a fixed rear window as wide as the bed and another large sliding side window, lots of daylight pours in. I enjoyed lying in bed in the morning, looking out the window and watching birds toss seeds out of the neighbor's bird feeder.

Light also comes in from the vent over the bed; this vent is one of three in the 23H, but only the one located in the bathroom has a fan. The thermostat for the 19,000-Btu Airxcel furnace is conveniently located on the wall alongside the bed, so you don't even need to get out from under the covers to set the temperature on chilly mornings. However, with 90-plus-degree days at our site, the 13,500-Btu roof-mounted Coleman-Mach air conditioner was cranking



much of the time and kept the inside comfortable.

When it's dark out, there's still plenty of light over the bed with four overhead LEDs, plus two push-button reading lights. Actually, the "reading lights" are more like beacons; we believe just one would suffice. If you're sharing the bed and one person is reading by that light, the other person may as well, too — or put a pillow over his or her head. A dimmer, or a varying brightness setting, would be appreciated.

These same reading beacons are ceiling-mounted in the cabover bunk, plus there's bright LED lighting throughout. With dark, high-sheen Brazilian cherry flat-panel cabinet doors, the 23H has the potential to be dark inside, but is far from it thanks to





large windows and overhead vents that admit natural light. The dark wood ties in well with the light-colored Bayside II décor furniture, residential vinyl flooring and laminate countertops. The cabinet doors open toward the 7-foot-high ceiling via smooth gas struts, and most are out of the way of heads attached to tall people.

The kitchen is efficiently laid out with a Norcold 6-cubic-foot refrigerator located across from a three-burner range, oven and microwave. There's minimal counterspace between the range and dual-basin stainless-steel sink with pull-down sprayer, but enough space in back to hold little bowls, bottles and a small coffeemaker. The flip-up extension next to the range adds prep space, and while it is located near the

entry doorway, it doesn't completely block the area. In fact, this turned out to be a handy setup when retrieving bowls of various appetizers I'd stacked onto the extension to bring across the street for a potluck gathering. Grab handles inside and outside the entry door make ingress/egress easy, though it would be nice if there was padding at the top of the entry door's interior for taller folks.

Speaking of which, cabinets over the entry door and microwave are useful for tall people. At 5 foot 9 inches, I could reach into the front part of those cabinets, but stuff that had slid to the back during travel was a struggle to retrieve. Below the counter extension, near the RV's control panel, is a handy 120-volt AC GFCI outlet for plugging in appliances, and under the sink is a cubby for a large provided waste bin so trash is out of sight.

A 5-inch step up from the galley is the bathroom (and bed), an efficient, subtle way of separating the two from the living area. It's also handy to scoot to the edge of the bed in the morning, take two steps and be in the bathroom. It did take time to remember to step down when coming out of the bathroom, however, since the step could easily be missed when you're not used to it.

The bathroom is roomy, and the plastic toilet, angled out from the corner, maximizes floor space. A mirrored medicine cabinet and cabinet under the



A large and bright bathroom has a roomy shower with a screen that whisks water off as it retracts. Not shown are the door-mounted towel racks that get high marks for sturdiness.

WHAT'S HOT

More than 4,000 pounds of ccc, spacious exterior storage accessible from two sides, included portable table, large electric awning with LED lights

WHAT'S NOT

Putty-patched staple marks on bathroom wall, lack of fans in galley, limited counterspace in kitchen



plastic single-basin sink has enough room to store the essentials. We were most impressed with the three towel racks mounted to the bathroom door with quality hardware, presumably to handle the weight of towels and clothing that will no doubt be slung over them.

I stepped up a foot into a spacious 20-by-34-inch shower pan, boasting a total of 6 feet 6½ inches of headroom with the overhead skylight, and closed the retractable screen. A lot of shampoo bottles and such can occupy the three big shelves. The hand-held sprayer has a shut-off valve, water pressure was good and warm water is supplied from the 6-gallon water heater. So far, so good. Except when I wanted to get out, I couldn't. As I struggled to open the shower door with a bit more force, the bottom rail came off the track. Now I was really stuck.

"Hellooooo, anyone out there?" This could be embarrassing. Fiddling with the door and tugging it in from the bottom, it finally retracted with a snap. After being released and inspecting the door, I saw that the "Hold and press in"-labeled handle was on the outside ... aha! The shower frame had been mounted in the wrong position! We'll chalk that up to an employee who was on a mental hiatus that day — evidently the same one

THOR FREEDOM ELITE 23H

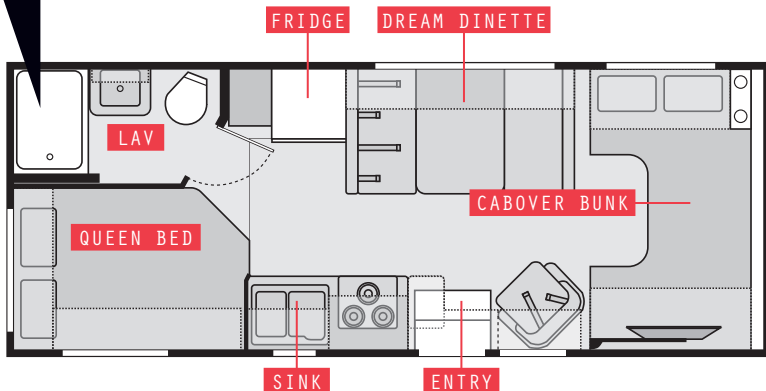

Good Sam Extended Service Plan Pays for Your Repairs

COVERED
\$850

Water Heater

COVERED
\$2,250

Leveling Jack Hydraulic

COVERED
\$1,100

Air Conditioner



COVERED
\$1,750
Refrigerator

COVERED
\$4,000
Transmission

COVERED
\$12,250
Engine (Gas)

GOOD SAM EXTENDED SERVICE PLAN FEATURES:

- ✓ Pay as You Go, Not All at Once
- ✓ 100% Satisfaction Guarantee – Backed by Good Sam
- ✓ Reliable Protection Against Unexpected Mechanical Breakdowns
- ✓ We Pay for Your Repairs – At Any Repair Facility
- ✓ Travel Benefits Such as Hotel & Rental Car Reimbursement

CALL OR CLICK FOR A FREE, NO OBLIGATION QUOTE

GoodSamESP.com/MH0717

866-298-9827



Good Sam
AUTO & RV

PROTECT YOURSELF FROM HIGH REPAIR BILLS TODAY

Extended Service Plan
MBI

*All program benefits are subject to limitations set forth in the current Terms & Conditions. ESP is available to U.S. residents only. Designed for the Good Sam Club by Affinity Brokerage, LLC. ©2017 Good Sam Enterprises, LLC. GOOD SAM and the GOOD SAM ICON are registered trademarks of Good Sam Enterprises, LLC. Unauthorized use of any of GSE, LLC's trademarks is expressly prohibited. All rights reserved. ADMH9827JUL17 GSP52625 - 0317

Specifications

Chassis

Model	Ford E-450
Engine	6.8L Triton V-10
Sae Hp	305 hp @ 4,250 rpm
Torque	420 lb-ft @ 3,250 rpm
Transmission	6-speed automatic with overdrive
Axle Ratio	4.10:1
Tires	LT225/75R16
Wheelbase	158"
Brakes	4-wheel disc with ABS
Suspension F/R	Coil/Leaf springs
Fuel Capacity	55 gal
Fuel Economy	9.68 mpg
Warranty	3 years/36,000 miles (chassis), 5 years/60,000 miles (drivetrain)

Coach

Exterior Length	24' 10"
Exterior Width	8' 3"
Exterior Height (with A/C)	10' 10"
Interior Width	8'
Interior Height	7'
Construction	Welded tubular steel floor/welded tubular aluminum framed one-piece TPO roof and cage, Vacu-Bond laminated roof, walls and floor with block foam insulation; one-piece fiberglass front cap
Freshwater Capacity	40 gal
Black-Water Capacity	24.5 gal
Gray-Water Capacity	38.5 gal
Water-Heater Capacity	6 gal
LP-Gas Capacity	10 gal
Air Conditioner	13,500 Btu
Furnace	19,000 Btu
Refrigerator	6 cubic-foot
Converter	55-amp
Battery	Group 24 (chassis); (1) 12-volt (coach)
AC Generator	4 kW
MSRP	\$85,095
MSRP as Tested	\$85,095
Warranty	Limited 1 year

Wet Weight

(Water and fuel tanks full, no supplies or passengers)

Front Axle	3,700 lbs
Rear Axle	6,740 lbs
Total	10,440 lbs

Chassis Ratings

GAWR, F/R	5,000/9,600 lbs
GVWR	14,500 lbs
GCWR	22,000 lbs
ROCCC	4,060 lbs (deduct weight of passengers for net cargo capacity)

GAWR	Gross Axle Weight Rating
GVWR	Gross Vehicle Weight Rating
GCWR	Gross Combination Weight Rating
ROCCC	Realistic Occupant and Cargo Carrying Capacity Rating (full water, no passengers)



An inviting living area seats five comfortably and the sliding window over the dinette allows for good airflow. A 40-inch TV is housed at the foot of the cabover bunk and swivels out for viewing.

who hastily patched the staple marks with putty so that little light-colored blots were visible on the bathroom wall adjacent to the bed. These small concerns were in contradiction to the rest of the Freedom Elite's overall good quality. When the shower screen works as intended, a built-in squeegee whisks water off as it retracts.

In addition to the exterior storage compartment, another feature that gets high marks is the electric awning with LED lights that runs the length of the 23H. Not only is it big lengthwise, it also offers a lot of coverage, so much so that other RVers stopped by to comment on it and check it out. A few were envious, especially since they'd been broiling under the sun in 92-degree weather.

After several relaxing days, I climbed back into the cab for the drive home. I liked how I could see out of the back window from the rearview mirror while in the driver's seat; though with the back window located so high up, you can't see cars, but other RVs and large trucks approaching are sometimes visible. Another nice feature worth noting is an emergency engine start switch that allows the engine to be started with an extra shot of electricity from the house battery if the engine battery discharges.

It was another hot day, so I started

the engine, blasted the dash A/C and aimed the four ducts in a row toward myself. The cloth captain's seats with high headrests were comfy. It can get a bit noisy in the cab from windblast while underway, but no major squeaks or rattles came from the back. A touch-screen AM/FM dash radio has a backup monitor, but no GPS. The RV's dash-mounted stereo has interior speakers only. The exterior mirrors are manually operated and the cab floor is rubber, but that makes it easier to keep clean. There's also storage galore, and cup-holders in the doghouse.

The Freedom Elite line is manufactured by Thor exclusively for Camping World. Overall, we liked the 23H. It's simple and manageable, yet doesn't require owners to give up essential amenities or comfort. It's set up for a family while underway, too, with two seatbelts in the dinette bench and one in the barrel swivel chair. Add to this a friendly price point and an impressive 4,060-pound cargo carrying capacity, and you needn't worry what (or who) you bring along for the ride. Whether a party of one or a family, the 23H is perfect for those times when you just need to get away from it all. **M**

Thor Motor Coach

800-860-5658, www.freedom-elite.com

They can remind you of being a kid, or how you still are one at heart. You never know when those moments may happen, but you'll be ready to go when they do.



*Ready.
Set.
Go!*



GEMINI[®]



Thor Industries, Circle 142 on Reader Service Card

thormotorcoach.com

800.860.5658

JUST RIGHT

These amenity-rich Class A motorhomes are easy to maneuver without scrimping on livability

The freedom to explore the countryside in the residential comfort of a motorhome is easily one of the most attractive aspects of the lifestyle. But sometimes, bringing along all the conveniences of home can lead potential owners to a Class A coach so large that they may find it difficult to maneuver on the road or within the tight confines of a campground. This issue gets even more complicated if owners tend to set up camp in areas off the beaten path, or in campgrounds that impose a length limit. As such, the often difficult decision of sacrificing living space or additional amenities needs to be addressed in favor of a more compact motorhome that

may be easier to handle, or one that won't get turned away from a site near a favorite fishing hole because it's too long. But wouldn't it be great if we could have the best of both worlds: a moderately sized rig that's fully equipped with everything you've come to expect in a Class A motorhome?

To help in your search for a motorhome that's "just right" to achieve a healthy balance between size and amenities, we've included a number of fully outfitted rigs that should allow owners to camp at most of their favorite sites in comfort and style, without missing out on the ultimate in livability.



COACHMEN PURSUIT

The Coachmen Pursuit 31SB features a spacious interior and a number of surprising touches designed to make the most of its sub-32-foot floorplan. From the drop-down overhead bunk up front to the pedestal table in the cockpit to the pullout pantry with a countertop in the galley, it's obvious the Pursuit is meant for the space-conscious motorhome owner. The king bed in the master sits across from dual mirrored wardrobes and a 32-inch LED TV/storage unit, while the 38-by-24-inch shower features a skylight to enhance the feeling of spaciousness. The large 85-inch sofa in the living area offers a great view of the 50-inch LED TV mounted above the dinette. The Pursuit features all laminate flooring for easy cleanup, while other highlights include solar night shades, a porcelain foot-flush toilet and self-closing drawer guides. Outside, the Pursuit sports high-gloss side walls with an Azdel backer that Coachmen says have less than a 0.1 percent chance of delamination.



Chassis	Ford F-53
Engine	Triton 6.8L V-10
Fuel Cap	80 gal
GVWR	18,000 lbs
Exterior Length	31' 9"
Exterior Width	8' 6"
Exterior Height with A/C	12'
Wheelbase	208"
Freshwater Cap	50 gal
Black-/Gray-Water Cap	35 gal/ 35 gal
LP-Gas Cap	20 gal
Base MSRP	\$115,875

Coachmen RV
574-825-5821, www.coachmenrv.com

Photos courtesy of the manufacturers

FLEETWOOD FLAIR LXE

It's easy to feel like the walls are closing in when the entire family spends an extended amount of time in a motorhome. The Fleetwood Flair LXE 31B keeps things spacious by incorporating two 25-by-70-inch bunk beds into a free-flowing, open floorplan. The Dream Dinette and the 42-by-60-inch sofa bed can be converted to comfortable sleeping positions, and

the walk-around queen bed in the master is flanked by dual nightstands. A wardrobe/dresser unit, plus an additional closet for hanging shirts, offer plenty of clothes storage in the bedroom, while a pantry located across from the bunk beds will allow easy access for snacks for the kids. The galley is equipped with solid-surface countertops, a three-burner cooktop,

a residential dual-basin sink and a convection microwave, plus buyers can opt for an 11-cubic-foot residential refrigerator. Driver conveniences include backup and sideview cameras, a blind-spot window and soft-touch captain's chairs with reclining back and slide controls. An exterior entertainment center expands the usable living space outdoors.



Chassis	Ford F-53
Engine	Triton 6.8L V-10
Fuel Cap	80 gal
GVWR	18,000 lbs
Exterior Length	32' 9"
Exterior Width	8' 6"
Exterior Height with A/C	12'
Wheelbase	208"
Freshwater Cap	60 gal
Black-/Gray-Water Cap	37 gal/ 37 gal
LP-Gas Cap	14 gal
Base MSRP	\$118,650

Fleetwood RV
800-854-1344, www.fleetwoodrv.com

FOREST RIVER FR3

Forest River has dubbed its popular FR3 a crossover motorhome, meaning it combines the family-friendly livability and affordability of a Class C motorhome with the space, convenience and styling of a Class A. The FR3 30DS's Class C lineage is immediately apparent when viewing the powered foldaway bunk up front, but the wraparound booth dinette, sofa bed with foot rests and residential king bed in the master are all Class A grade, as is the wall of wardrobes and the LED TV in the bedroom. The split lav is located amidships, with the large 36-by-30-inch shower across the aisle from the spacious toilet and large counter. The galley features custom solid-surface countertops, a flip-up counter extension and a large dual-basin stainless-steel sink. The flush-floor throughout (eliminating the step down into the cockpit) is a nice touch that aids in livability. New for 2017 is the X-Package option, which includes an 18-cubic-foot gas/electric refrigerator, dual A/C units, a 5.5-kW Onan genset and 50-amp service.



Chassis	Ford F-53
Engine	Triton 6.8L V-10
Fuel Cap	80 gal
GVWR	18,000 lbs
Exterior Length	31' 10"
Exterior Width	8' 3.5"
Exterior Height with A/C	12' 2"
Wheelbase	190"
Freshwater Cap	57 gal
Black-/Gray-Water Cap	42 gal/ 42 gal
LP-Gas Cap	24.5 gal
Base MSRP	\$123,298

Forest River Inc.
574-389-4600, www.forestriverinc.com



JUST RIGHT



FOREST RIVER GEORGETOWN GT3

Don't let the Georgetown GT3's designation as the product line's entry-level motorhome fool you: The spacious motorhome includes all the features of much higher-priced models. The living area in the 30X3 is opened up with a 36-inch-deep slideout that contains the sofa and dinette. The rear master bedroom offers a king bed housed in a slideout, and the split lav maximizes usability by separating the shower from the toilet and sink. The interior features a wide 30-inch entry door, solid-surface countertops throughout and Beauflor vinyl flooring to help with cleanup duties. An optional manual or electric overhead bunk adds sleeping capacity. A popular option on the 30X3 is the exterior camp kitchen, which includes a refrigerator with freezer, stainless-steel sink (with separate holding tank), countertop, cabinet and LP-gas grill with a stand and quick-connect fittings. New for 2018 is the 50-amp package, which also includes a 5.5-kW Onan generator and dual A/C units.

Chassis	Ford F-53
Engine	Triton 6.8L V-10
Fuel Cap	80 gal
GVWR	18,000 lbs
Exterior Length	31' 11"
Exterior Width	8' 4"
Exterior Height with A/C	12' 2"
Wheelbase	190"
Freshwater Cap	50 gal
Black-/Gray-Water Cap	42 gal/ 42 gal
LP-Gas Cap	24.5 gal
Base MSRP	\$122,986

Forest River Inc.
574-389-4600, www.forestriverinc.com

HOLIDAY RAMBLER ADMIRAL

The ride to the campsite or RV park can really set the tone for the rest of the trip. White-knuckle swaying and a stiff suspension can put the driver in a bad mood, something that can easily ruin the rest of the experience. To help make the drive more enjoyable, Holiday Rambler has partnered with MORryde to employ the REV Control Ryde

system. Rubber shear springs work in concert with leaf springs to absorb road shock, and the RCR system features "anti-dive" technology, utilizing a sway bar to help reduce front-end dive. But the Admiral is much more than a smooth ride. The 30U features an open floorplan, a rear king bed, plenty of seating and a sizable bathroom. There's also a

soft-touch vinyl ceiling, premium furniture and LED interior task lighting. The fully equipped galley is decked out with solid-surface countertops and tile backsplash, and high-gloss cabinetry and doors with hidden hinges add a touch of elegance. The exterior entertainment center is a great option for a movie under the stars.



Chassis	Ford F-53
Engine	Triton 6.8L V-10
Fuel Cap	80 gal
GVWR	18,000 lbs
Exterior Length	30' 11"
Exterior Width	8' 6"
Exterior Height with A/C	12'
Wheelbase	190"
Freshwater Cap	50 gal
Black-/Gray-Water Cap	35 gal/ 35 gal
LP-Gas Cap	14 gal
Base MSRP	\$116,243

Holiday Rambler
800-648-6582, www.holidayrambler.com

Better Than Home



Inspired by the spirit of adventure and resolved to make the future perfect – Furrion reimagines life on the road. High-performance kitchen appliances are specifically built to enhance every outing with luxuries beyond the norm. And inherent safety features allow you the comfort and peace-of-mind to live freely, with the convenience of home. Experience the effects of a limitless lifestyle today.



FSRI22LA-SS



FG4ZSA-SS



FIH2ZEA-BG



FMCM15-SS



FDW18SAS-SS

FURRION

JUST RIGHT

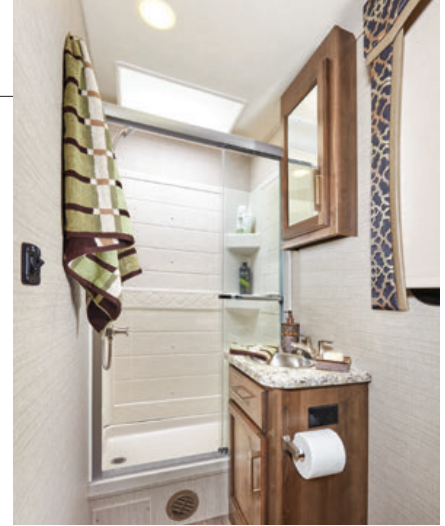

JAYCO ALANTE

With updated décor including new wood colors and subway-tile backsplashes, Jayco's 2018 Alante lineup packs in the luxury along with the style. Standards like frameless windows, roller shades, slam-latch baggage doors and a one-piece fiberglass roof are welcome inclusions. As with all Jayco motorhomes, the Alante sports JRide technology, which includes a computer-balanced driveshaft, jounce bumpers and front and rear sway bars. Add to that the large windshield with narrow A-pillars to improve sight lines and the Garmin Infotainment dash stereo with detachable tablet equipped with an RV GPS, and owners will have a smooth ride all the way to the RV park. Outside, the 26X shown here features an exterior entertainment center with a 39-inch LED TV, speakers and a DVD/CD player, perfect for watching the game under the 13-foot awning. After the final whistle, owners can retire inside to the walk-around queen bed, sofa bed and convertible dinette, or they can opt for the drop-down cab overhead bunk. The fully equipped galley features solid-surface countertops and hardwood cabinet doors.

Chassis	Ford F-53
Engine	Triton 6.8L V-10
Fuel Cap	80 gal
GVWR	16,000 lbs
Exterior Length	27' 5"
Exterior Width	8' 5"
Exterior Height with A/C	12' 5"
Wheelbase	158"
Freshwater Cap	53 gal
Black-/Gray-Water Cap	32 gal/ 40 gal
LP-Gas Cap	17 gal
Base MSRP	\$115,088

Jayco Inc.
574-825-5861, www.jayco.com

NEWMAR BAY STAR SPORT

Newmar's Bay Star Sport is offered in seven floorplans, all a manageable 34 feet in length or less. The 3208 is a roomy double-slide model with a sizable front kitchen and dining area. The fully equipped galley is highlighted by solid-surface countertops and a stainless-steel sink, while the living area features a large 84-inch L-shaped sofa, separate dinette and a nifty dry-bar surface below the LED TV. Owners will no doubt appreciate the large pantry and linen closet, both just an arm's reach from the kitchen. The amidships lav is split, with a large 36-by-30-inch shower streetside. The master offers a queen bed with shirt wardrobes and a chest of drawers, plus an optional TV. A pocket door closes off the room for additional privacy. Outside, the fully painted graphics are topped with a clearcoat finish. A Carefree power side awning, frameless windows and lighted exterior storage all make life a bit easier at the campground.



Chassis	Ford F-53
Engine	Triton 6.8L V-10
Fuel Cap	80 gal
GVWR	20,500 lb
Exterior Length	32' 11"
Exterior Width	8' 5.5"
Exterior Height with A/C	12' 4"
Wheelbase	200"
Freshwater Cap	75 gal
Black-/Gray-Water Cap	40 gal/ 60 gal
LP-Gas Cap	25 gal
Base MSRP	\$114,730

Newmar Corp.
800-731-8300, www.newmarcorp.com

YOUR ESSENTIAL 2017 RV TRAVEL GUIDE RESOURCE!

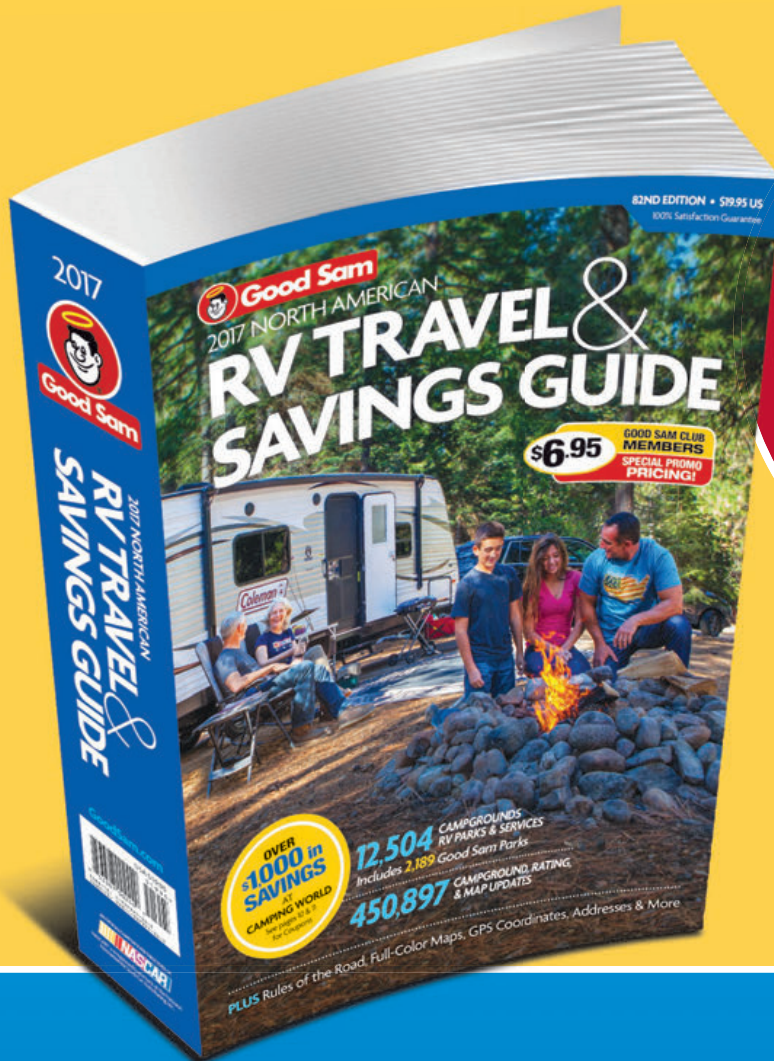

CLUB SALE
ONLY
\$6.95

CLUB MEMBERS
Save 65%

2017 Good Sam RV Travel & Savings
Guide #95717 | Reg. \$19.95 | 

- **UPDATED!** 12,504 Campgrounds, RV Parks and Services
- **INCLUDES** 2,100+ Good Sam Parks, Good Sam's Trusted 10/10/10 Ratings
- **PLUS,** Ultimate RV Trips, RV buying advice lifestyle tips & MUCH MORE!
- **\$1,000 SAVINGS** with Camping World Coupons
- **EASY** user-friendly full color state and provincial maps

DON'T MISS OUT—ORDER TODAY!

ON SALE NOW for Good Sam Club Members
CampingWorld.com | 1.888.857.6625 | SuperCenters Nationwide

JUST RIGHT



THOR A.C.E. 27.2

A walk-around king-size bed in a motorhome less than 29 feet long? Thor's A.C.E 27.2 packs in quite a bit of livability in its dual-slide floorplan, including sleeping positions (and seatbelts) for six. The Dream Dinette up front seats four and is situated across from the 68-inch jackknife sofa; both areas offer a nice view of the 40-inch LED TV. A power drop-down bunk above the cockpit is standard. The split galley features a three-burner range, microwave and oversized single-basin sink streetside, while the curbside fridge is flanked by a large storage cabinet on one side and a convenient broom closet on the other. The laminate countertops are accented with a glass-tile backsplash. The rear bathroom is sized right to get the job done, and offers owners a porcelain foot-flush toilet. Outside, a 32-inch LED TV on a manual swivel provides campsite entertainment.

Chassis	Ford F-53
Engine	Triton 6.8L V-10
Fuel Cap	80 gal
GVWR	16,000 lbs
Exterior Length	28' 9"
Exterior Width	8' 3"
Exterior Height with A/C	12' 2"
Wheelbase	178"
Freshwater Cap	50 gal
Black-/Gray-Water Cap	40 gal/ 73 gal
LP-Gas Cap	88 lbs
Base MSRP	\$115,950

Thor Motor Coach
877-855-2867, www.thormotorcoach.com

TIFFIN ALLEGRO BREEZE

The Tiffin Allegro Breeze 31 BR is a diesel pusher that comes in just under 32 feet in length. The 31 BR makes the most of its three slides: One streetside slide contains the fridge and sofa bed, one curbside houses the dinette and galley, while the last one is utilized to expand the master around the walk-around queen bed. And, by situating the bed in the slideout on the streetside, space for a large closet spanning the entire width of the rear provides an impressive amount of storage space for a coach this size. For even more storage, the large galley hosts an upgraded pantry, in addition to solid-surface countertops, tile backsplash, microwave convection oven and three-burner cooktop. A residential fridge is available as an option. Entertaining is made easy with the LED TV with surround sound, plus electric fireplace for added heat or ambiance. But it's hard to ignore the impressive powertrain, starting with the Cummins ISV5.0 engine mated to an Allison Automatic six-speed transmission, all designed to make getting to the RV park easier than ever.



Chassis	PowerGlide
Engine	Cummins ISV5.0 275
Fuel Cap	70 gal
GVWR	24,500 lbs
Exterior Length	31' 6"
Exterior Width	7' 11"
Exterior Height with A/C	11' 8"
Wheelbase	182"
Freshwater Cap	70 gal
Black-/Gray-Water Cap	33 gal/ 55 gal
LP-Gas Cap	20 gal
Base MSRP	\$240,120

Tiffin Motorhomes
256-356-8661, www.tiffinmotorhomes.com



We've got you covered where insurance leaves off.



Good Sam
TravelAssist 

PLANS STARTING AT

\$79.99*
~~\$129.99~~

WHY TRAVELASSIST?



Protects you and your family 24/7 in the event of an accident or illness while traveling



Worldwide Coverage for any type of travel. Includes cruises, air travel, and road trips!



Covers costs NOT covered by most insurance or Medicare.



Annual Membership costs hundreds less than competitors like MedJet or SkyMed

WHAT DOES TRAVELASSIST COVER?



Emergency Medical Transportation



Prescription & Glasses Replacement Assistance



RV/Vehicle Returned to Your Home



Return of Deceased Remains



Transportation Home



Pet Care & Return Assistance

NO HEALTH SCREENS REQUIRED! NO AGE LIMITS!

LIMITED-TIME OFFER – Ends June 30, 2017. Sign up Now!

CALL 1-800-547-9798 or visit GoodSamTravelAssist.com

*Introductory offer for Good Sam Members who are first-time buyers only. Offer expires June 30, 2017. ©2017 Good Sam Enterprises, LLC. GOOD SAM and the GOOD SAM ICON are registered trademarks of Good Sam Enterprises, LLC. Unauthorized use of any of Good Sam Enterprises, LLC's trademarks is expressly prohibited. All rights reserved. GTA52661 - 0317

JUST RIGHT



WINNEBAGO SUNSTAR

Available in six family-friendly floorplans, the Winnebago Sunstar is a good choice for a first Class A, or for those looking to downsize. The Sunstar 29VE utilizes a full-wall slide to open the floorplan up considerably, housing (from front to back) the sofa bed, galley, and wardrobe/storage in the master bedroom, the latter of which features a walk-around queen bed with storage on both sides. The amidships lav is big enough to heed the call, while the fully equipped galley has a surprising amount of solid-surface countertop prep space. The sofa bed up front faces the 40-inch LED TV and is positioned near the swivel cab seats. An optional powered StudioLoft adds sleeping space for guests. Throughout the coach, MCD blackout roller shades and LED ceiling lights are most appreciated. Outside, the 29VE features an exterior kitchen, complete with stainless-steel grill, ice chest with lid and refrigerator sure to make owners the envy of tailgaters everywhere.

Chassis	Ford F-53
Engine	Triton 6.8L V-10
Fuel Cap	80 gal
GVWR	18,000 lbs
Exterior Length	30' 3"
Exterior Width	8' 5.5"
Exterior Height with A/C	12' 2"
Wheelbase	190"
Freshwater Cap	70 gal
Black-/Gray-Water Cap	40 gal/ 61 gal
LP-Gas Cap	18 gal
Base MSRP	\$108,360

Winnebago Industries Inc.
641-585-3535, www.winnebagoind.com

#1 ALL NATURAL
Moisture Absorption



Eliminate Musty Odors *Plus* Prevent Moisture Damage Inside Your RV

DampRid® continuously attracts & traps excess moisture to prevent musty odors

Put the hanging bag in your RV's closet or bathroom.



The hi-capacity tub features a sealed safety cover to prevent spills.



Place DampRid® in RV between uses & during storage to prevent musty odors
Available at all Retailers



Look for a money saving coupon under FIND A RETAILER at www.damprid.com

Aqua-KEM®

Demand the BEST!



NEW!

Powerful Odor Control Superior Waste Digestion

NEW Aqua-Kem® Shotz™ Micro Concentrates!



Grip...



Dispense...



Drop...



Store!

- Works around the clock in all weather conditions
- Liquefies waste and breaks down tissue **FAST** to prevent clogs
- Strong detergents clean tank walls and drain lines

From the RV Sanitation Expert

Theford Corporation, Circle 141 on Reader Service Card

THETFORD
Going Places

www.thetford.com

A3283

By Bob Livingston

SUSPENSION TRANSFORMATION

New system using compressible liquid takes ride comfort and handling of motorhomes built on the Ford F-53 chassis to higher levels

For many years, a gas engine-powered Class A motorhome built on the Ford chassis was the only such game in town — and still is today. These motorhomes, perched on Ford's venerable F-53 chassis, represent the biggest segment in the motorized RV industry. While Ford's chassis have a proven track record for reliability, the handling traits resulting from underpinnings that have seen limited change over the years are less than stellar.

Compromises are made in a number of arenas to control costs and offer higher gross vehicle weight ratings (GVWR) that can handle larger motorhomes with more amenities in response to customer demand. On the suspension side, leaf springs and

shock absorbers are the quintessential components in handling weight and relative driving comfort. But, owners of motorhomes on the Ford chassis have always complained about the rough ride, imprecise steering input and body roll.

Lightly loaded, these motorhomes usually exhibit decent handling characteristics, but once loaded to near maximum GVWR, and especially when heavy items are stored in higher-positioned compartments, body roll becomes much more apparent. Generally, at this point, it's difficult for passengers to move about while on the road, and the driver will have to maneuver defensively to keep the motorhome on an even keel.

A few aftermarket products designed to improve the ride and handling of the F-53 chassis have entered the scene over the years, but the latest from LiquidSpring, called a Compressible Liquid Adaptive Suspension System (CLASS), is



The test motorhome was driven over the shop driveway before and after the installation. Body oscillations were reduced from four to five to just one after the CLASS components were installed.



1



2



3



4



5

destined to change the paradigm of how owners view — and drive — motorhomes built on the F-53 chassis.

The CLASS rear suspension is a five-link system that takes the place of the standard leaf springs and shocks, and uses sophisticated electronics to manage compressible liquid silicone via specially designed struts and control arms — improving stability while reducing road shock and vibrations. To find out how it works, we installed a system in a 2011 Winnebago Adventurer which, loaded to its 22,000-pound fighting weight, exhibited all the negative handling behaviors common with the Ford chassis. The motorhome had 16,261 miles on the odometer.

Handling problems are not new; the auto industry has been working on solutions for more than 100 years. Shock absorbers have been the auto industry's bread-and-butter solution for years, with air bags entering the scene 50 years ago. While air bags help somewhat, they are still subject to the same tradeoffs between ride quality and handling. Shock absorbers are expected to be the superheroes, but ironically, they can only provide limited control and once they heat up, damping can be compromised.

LiquidSpring ventured into the suspension business while on a

[1] Before the CLASS components can be installed, the existing leaf springs, brackets, shocks and hardware are removed. Only the factory sway bar remains in place. [2] After removing the factory suspension components, the net gain in weight is around 200 pounds; determining axle and tire capacities before the installation is important. [3] Design of strut module may look like a conventional hydraulic cylinder, but here the chambers are equally pressurized and react via changes in fluid volume in proportion to load. [4] Hydraulic hoses and fittings are commercial-grade and able to withstand many years of rigorous use. [5] Holes in the frame are made by a magnetic frame drill, which provides better accuracy.

mission to smooth out the ride in huge off-road trucks used in underground mining. These trucks were known to shake people uncontrollably, decreasing production due to fatigue and injury. Most engineers were skeptical of compressible liquid, but the company made it work,

prototyping a system for mining and other fields that smoothed out the ride so dramatically that it doubled production capability and prolonged suspension life on these big rigs remarkably.

While the company's mining-truck invention taught it how to change

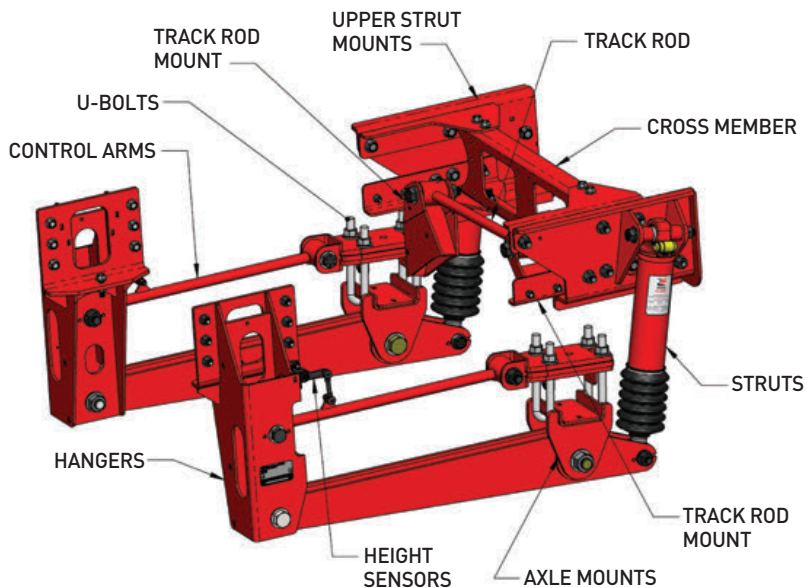



6



7



stiffness through compressible liquid, there were no electronics at the time to manage the process. Fast forward to 2012 and company engineers found a way to learn the characteristics of fluid using electronics and introduced a product to the bus and ambulance industries that offered dramatic improvements in ride quality. The ambulance industry was actually able to document improvements in patients' health, which to that point had often deteriorated (fatigued) by adverse vibrations and the bumpy ride to the hospital. Today, 90 percent of these vehicles equipped with improved suspension technology employ the LiquidSpring components, according to the company.

From this experience and success, a new system was developed for the Ford F-53 and cutaway chassis.

To get here, company engineers were charged with understanding what happens to fluid under different temperatures and pressures,

[6, 7] Bracket for the track bar is welded to the rear axle (all other brackets are bolted). This is where expert welding is important to prevent damage to the axle housing. Track bar [8] prevents lateral movement during up and down travel of the suspension in response to road conditions. [9] Upper and lower [10] control arms are mounted to the frame on both sides of the axle, and pivot in response to suspension movement. The OEM sway bar is connected to the rear axle and factory frame rails.

and how it flows. In the end, the system had to work harmoniously with the mechanical aspects of a suspension, as well as eliminating the common tradeoffs between ride quality and handling. Sensors used for suspension height, speed, braking and steering input are used to process information through proprietary algorithms that allow the system to react to body roll in milliseconds.

The system has three ride modes: comfort, normal and sport. Comfort bias is toward a better ride, while the sport mode focuses on handling.

The controls allow the motorhome to travel in the comfort mode for the best ride quality and will automatically respond to driving conditions, seamlessly changing the spring rate and adjusting load levels (compensating for payload distribution) without driver input. The driver can elect the sport mode, which will stiffen the spring rate regardless of conditions. The driver can also adjust height up to 4 inches using the manual controls on the interface panel that's mounted on the dash as long as speed is slower than 10 MPH.

[11] Secondary fluid volume vessels are attached to each side of the frame and are held in place with loop clamps. [12] Hydraulic hoses connect the vessels to the struts through which the compressed liquid is distributed in response to "spring rate." [13] Power module/fluid reservoir with ECU [14] is attached to the frame rail using a special bracket. Hoses are routed from the reservoir to the secondary fluid vessels. ECU monitors road conditions and sends signals to each strut, via fluid volume, to change stiffness and damping as needed to maintain control and ride quality.



11



12

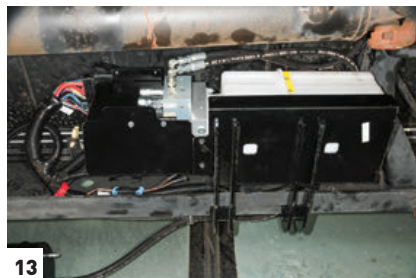

13



14



Installation of the components must be relegated to professionals and although it can be retrofitted to an existing motorhome, the company is focusing on the OEM segment to offer the system from the factory. For testing, we contracted with Redlands Truck and RV Performance Center, Redlands, California, to install the system on the aforementioned motorhome. The Redlands technicians are experts on working on suspensions and are noted for their work on big Class A's.

Before the new parts could be installed, all the existing suspension components were removed from the chassis, with the exception of the factory sway bar. All the new parts were bolted to the axle and frame except for one bracket, which was welded to the axle. Expert knowledge in welding to the axle is required, since using the wrong technique can result in a damaged axle housing. The parts exchange results in an approximate 200-pound increase in overall weight of the motorhome, most of which is on the rear axle.

The entire process took 30 hours and once completed, the system has a factory-installed look that will make any owner who enjoys gawking at mechanical devices proud. Of course, labor costs can reach \$4,500, and added to the approximate \$8,000 price of the components, puts the investment at a sizable plateau. The system requires negligible maintenance and is covered by an extensive warranty. Service centers experienced

with motorhome chassis are capable of handling repairs, if they become necessary.

Was it worth it? The answer is a resounding "yes!"

Before we installed the CLASS, we set up a test course to establish baselines. The motorhome was loaded for a typical trip and exhibited the typical adverse handling traits that the owner simply tolerated. Right out of the gate, the body oscillated four to five times negotiating the driveway. The factory sway bar is designed to help body roll, but is not compliant enough to do much on the driveways. Once the new system was installed, the oscillations were virtually gone.

On the second part of the course, we drove into an RV park with undulating

gravel roads. Rocking back and forth was the most annoying aspect of the drive, with increased body roll while negotiating the turns — even at very slow speeds. Vibrations and suspension shock caused by ruts in the road produced the expected elevated noise level that competed with normal conversations. In this segment, the LiquidSpring system tamed the body roll, reduced noise to a much quieter level and the rocking and bounce were squelched.

Driving on city streets resulted in the most dramatic differences before and after. Dips in the road, especially those in the middle of the turning zone, whipped the motorhome from side to side, throwing around passengers trying to stand in the aisle and/or

[15] A single strut on each side is connected to the frame and the control arms. The struts are the heart of the system, which is managed by fluid volume controlled by the ECU. Compressed liquid is not affected by temperature, so damping is consistent on all types of roads. **[16]** Control panel is mounted on the dash where it can be reached easily by the driver. Ride control and height are managed by clearly marked buttons; lights inform the driver of ride mode and in the event of a system problem. Diagnostic codes can be used to troubleshoot the system, if necessary.



walk to the rear bedroom. Sitting on the bed was terribly uncomfortable, exacerbated by the constant jarring of the in-compliant stock suspension, and trying to sit up straight was virtually impossible when the motorhome was negotiating turns at intersections, even at very slow speeds. Body roll was just too pronounced.

On return visit to the same city streets, improvements in handling and comfort were so good, we thought we were on a different route. Side-to-side movement (body roll) was curtailed dramatically, completely changing the experience for the driver and passengers for the better. The ride was much softer, the jarring just about gone, and walking the aisle was much easier — and the passengers were no longer launched from their seats. In back, the comfort was improved to a point that sleeping on the rear bed in transit was actually possible without dreaming about being thrown around in a clothes dryer.

The real eye-opener was the ability to aggressively power into the turns, even on roads with dips in the middle of the pavement, maintaining complete control, sans body roll and with only slight bouncing, restoring suspension predictability and driver confidence.

In stock condition entering the freeway on a 90-degree onramp resulted in five oscillations of the body while the motorhome was maneuvered into a straight path; with the CLASS installed, that number was reduced to only one. Steering precision improved and wallowing disappeared, providing a much more controlled feeling for the driver. Jounce on concrete road seams was almost eliminated, making the ride feel like it was on an asphalt surface. Lane changes were much more controlled, with almost no body roll, and powering into sweeping bends in the highway resulted in virtually no driver distress.

While the investment in the LiquidSpring system is sizable, the results

make a strong case for those who are on the fence between deciding on a gasser or diesel pusher — or those who love their gas-powered motorhome but don't look forward to the drive. New motorhome exterior aesthetics, floorplan décor and amenities are closing the gap between the comfort level and livability of a gasser and pusher, and those who find ride and driving comfort paramount often pass on gasers due to the legacy suspension. The LiquidSpring system will change that thinking.

When it comes to improving road manners of the Ford F-53 chassis, the LiquidSpring system over delivers on the results. The CLASS transformation is truly a game changer for owners looking to move Class A gasser ride quality and handling to a higher level. **M**

Source

LiquidSpring

765-474-7816, www.liquidspring.com

New **RVibrake 3**
portable braking system for flat towing a car

A new frontier in braking
RVi has always been the face of innovation in braking. With wireless **Wi-Fi link** and **7" tablet screen**, we're taking it to the next level. Join us...won't you?

Shop  800.815.2159 | rvi3.com 

HARBOR FREIGHT

QUALITY TOOLS AT RIDICULOUSLY LOW PRICES

BADLAND SUPER COUPON

2500 LB. ELECTRIC WINCH WITH WIRELESS REMOTE CONTROL

Voted Best Winches

ITEM 61258 shown
61840/61297
68146/63476

SAVE \$70

Customer Rating ★★★★★

Super Coupon \$4999

Compare ~~\$6999~~ \$119.99

• Weighs 14.3 lbs.
• 11-1/4" W x 4-1/8" H

LIMIT 5 - Original coupon only. No use on prior purchases after 30 days from original purchase or without original receipt. Valid through 10/13/17

20% OFF

ANY SINGLE ITEM

LIMIT 1 - Coupon per customer per day. Save 20% on any 1 item purchased. *Cannot be used with other discount, coupon or any of the following items or brands: In-Store, Truck Club membership, Extended Service Plan, gift card, open box item, 3 day Parking Lot Sale item, compressors, floor jacks, saw mills, storage cabinets, chests or carts, trailers, trenchers, welders, Admiral, Bauer, CoverPro, Daytona, Earthquake, Hercules, Jupiter, Lynox, Pooder, Predator, StormCall, Tallgator, Viking, Vulcan, Zurich. Not valid on prior purchases. Non-transferable. Original coupon must be presented. Valid through 10/13/17.

FREE

WITH ANY PURCHASE

PITTSBURGH 6 PIECE SCREWDRIVER SET

ITEM 62728
62583/47770
62570 shown

\$797 VALUE

LIMIT 1 - Cannot be used with other discount, coupon or prior purchase. Coupon good at our stores, HarborFreight.com or by calling 800-423-2567. Offer good while supplies last. Shipping & Handling charges may apply if not picked up in-store. Non-transferable. Original coupon must be presented. Valid through 10/13/17. Limit one FREE GIFT coupon per customer per day.

7 FT. 4" x 9 FT. 6" ALL PURPOSE WEATHER RESISTANT TARP

ITEM 69249/69115/69137
69129/69121/877 shown

Customer Rating ★★★★★

Super Coupon \$299

Compare ~~\$429~~ \$8.48

SAVE 64%

LIMIT 3 - Original coupon only. No use on prior purchases after 30 days from original purchase or without original receipt. Valid through 10/13/17

26", 4 DRAWER TOOL CART

ITEM 95669 shown
61634/61952

• 580 lb. capacity

Customer Rating ★★★★★

Super Coupon \$999

Compare ~~\$1499~~ \$369.32

★ WINNER ★
- Truckin' Magazine

LIMIT 3 - Original coupon only. No use on prior purchases after 30 days from original purchase or without original receipt. Valid through 10/13/17

PITTSBURGH #1 SELLING JACKS IN AMERICA

RAPID PUMP® 1.5 TON ALUMINUM RACING JACK

ITEM 68053/62160
62496/62516
60569 shown

• 3-1/2 Pumps Lifts Most Vehicles
• Lightweight 34 lbs.

Customer Rating ★★★★★

Super Coupon \$5999

Compare ~~\$7999~~ \$129.99

SAVE \$70

LIMIT 5 - Original coupon only. No use on prior purchases after 30 days from original purchase or without original receipt. Valid through 10/13/17

CENTRALPNEUMATIC

21 GALLON, 2.5 HP, 125 PSI VERTICAL OIL-LUBE AIR COMPRESSOR

ITEM 69091/61454
61693/62803
67847 shown

Customer Rating ★★★★★

Super Coupon \$14999

Compare ~~\$17999~~ \$446.61

SAVE \$296

• Air delivery: 5.8 CFM @ 40 PSI, 4.7 CFM @ 90 PSI

LIMIT 4 - Original coupon only. No use on prior purchases after 30 days from original purchase or without original receipt. Valid through 10/13/17

CENTRALPNEUMATIC

3/8" x 50 FT. RETRACTABLE AIR HOSE REEL

ITEM 93897 shown
69265/62344

Customer Rating ★★★★★

Super Coupon \$5999

Compare ~~\$7999~~ \$198.45

SAVE \$138

LIMIT 4 - Original coupon only. No use on prior purchases after 30 days from original purchase or without original receipt. Valid through 10/13/17

PITTSBURGH

PNEUMATIC ADJUSTABLE ROLLER SEAT

ITEM 46319 shown
61160/61896/63456

Customer Rating ★★★★★

Super Coupon \$1999

Compare ~~\$2599~~ \$39.99

• 300 lb. capacity

LIMIT 4 - Original coupon only. No use on prior purchases after 30 days from original purchase or without original receipt. Valid through 10/13/17

PITTSBURGH

16 OZ. HAMMERS WITH FIBERGLASS HANDLE

ITEM 69006
60715/60714

ITEM 47873 shown
69005/61262

Customer Rating ★★★★★

Super Coupon \$399

Compare ~~\$489~~ \$17.99

SAVE 77%

LIMIT 5 - Original coupon only. No use on prior purchases after 30 days from original purchase or without original receipt. Valid through 10/13/17

tilting FLAT PANEL TV MOUNT

ITEM 62289
61807 shown

• 176 lb. capacity

Customer Rating ★★★★★

Super Coupon \$1499

Compare ~~\$2499~~ \$55.82

SAVE 73%

HOLDS FLAT SCREEN TV. UP TO 70 INCHES

LIMIT 6 - Original coupon only. No use on prior purchases after 30 days from original purchase or without original receipt. Valid through 10/13/17

PREDATOR

6.5 HP (212 CC) OHV HORIZONTAL SHAFT GAS ENGINE

ITEM 60363/69730
ITEM 69727 shown
CALIFORNIA ONLY

Customer Rating ★★★★★

Super Coupon \$9999

Compare ~~\$11999~~ \$389.99

SAVE \$290

LIMIT 5 - Original coupon only. No use on prior purchases after 30 days from original purchase or without original receipt. Valid through 10/13/17

PITTSBURGH

FOLDABLE ALUMINUM SPORTS CHAIR

ITEM 62314/63066
66383 shown

Customer Rating ★★★★★

Super Coupon \$1999

Compare ~~\$2999~~ \$39.99

SAVE 50%

LIMIT 3 - Original coupon only. No use on prior purchases after 30 days from original purchase or without original receipt. Valid through 10/13/17

PITTSBURGH

17 FT. TYPE IA MULTI-TASK LADDER

ITEM 62656/62514
67646 shown

Customer Rating ★★★★★

Super Coupon \$11999

Compare ~~\$13999~~ \$281.87

SAVE \$161

• Versatile - 23 Configurations
• Safe + Secure + Stable
• Super Strong - Holds 300 lbs.

LIMIT 3 - Original coupon only. No use on prior purchases after 30 days from original purchase or without original receipt. Valid through 10/13/17

GREENWOOD

1-1/4 GALLON HOME AND GARDEN SPRAYER

ITEM 61280/63124
63145/95692 shown

Customer Rating ★★★★★

Super Coupon \$899

Compare ~~\$1299~~ \$14.97

SAVE 39%

LIMIT 7 - Original coupon only. No use on prior purchases after 30 days from original purchase or without original receipt. Valid through 10/13/17

PITTSBURGH

1 TON CAPACITY FOLDABLE SHOP CRANE

ITEM 69512/61858
69445 shown

Customer Rating ★★★★★

Super Coupon \$9999

Compare ~~\$17999~~ \$269

• Boom extends from 36-1/4" to 50-1/4"
• Crane height adjusts from 82" to 94"
• Includes Ram, Hook and Chain

LIMIT 4 - Original coupon only. No use on prior purchases after 30 days from original purchase or without original receipt. Valid through 10/13/17

PITTSBURGH

17 FT. TYPE IA MULTI-TASK LADDER

ITEM 62656/62514
67646 shown

Customer Rating ★★★★★

Super Coupon \$11999

Compare ~~\$13999~~ \$281.87

SAVE \$161

LIMIT 3 - Original coupon only. No use on prior purchases after 30 days from original purchase or without original receipt. Valid through 10/13/17

HaulMaster

1-1/4 GALLON HOME AND GARDEN SPRAYER

ITEM 61280/63124
63145/95692 shown

Customer Rating ★★★★★

Super Coupon \$899

Compare ~~\$1299~~ \$14.97

SAVE 39%

LIMIT 7 - Original coupon only. No use on prior purchases after 30 days from original purchase or without original receipt. Valid through 10/13/17

GREENWOOD

1-1/4 GALLON HOME AND GARDEN SPRAYER

ITEM 61280/63124
63145/95692 shown

Customer Rating ★★★★★

Super Coupon \$899

Compare ~~\$1299~~ \$14.97

SAVE 39%

LIMIT 7 - Original coupon only. No use on prior purchases after 30 days from original purchase or without original receipt. Valid through 10/13/17

Use Coupons: In-Store, HarborFreight.com or 800-423-2567

At Harbor Freight Tools, the "Compare" or "comp at" price means that the same item or a similar functioning item was advertised for sale at or above the "Compare" or "comp at" price by another retailer in the U.S. within the past 180 days. Prices advertised by others may vary by location. No other meaning of "Compare" or "comp at" should be implied. For more information, go to HarborFreight.com or see store associate.

By Chris Hemer

THE REPLACEMENT

When a motorhome's AC generator finally bids farewell, installing a new factory model is the best solution

Out of sight, out of mind. It's one of those expressions that applies to so many things in our lives, from distant relatives to household chores. It's just human nature — if something isn't right in front of us, or we're not reminded of it in some way, it tends to fade into the background as more pressing concerns take priority.

Motorhomes in particular tend to suffer from this kind of neglect. Because the average RV owner only uses his/her motorhome four to five times a year, the rest of the time it sits unused, and usually unmaintained. Unlike a car, which may only suffer from low tires and a dead battery after

a few months, a motorhome's various systems require frequent attention to keep them in tiptop shape when the travel season arrives.

Chief among these is the humble generator. Its mission in life is to work, to run frequently under load to create 120-volt AC power for appliances like

the air conditioner, hair dryer, coffee maker or other daily essentials. Its enemy is dormancy; to sit unused for months at a time can create numerous problems, from hard starting and rough running to not starting at all. That's why most generator service professionals recommend that a generator be run at least once a month under load for half an hour or more to make sure it can be relied upon for the next trip you have planned.

Quite apart from the costs and time involved with generator repair,



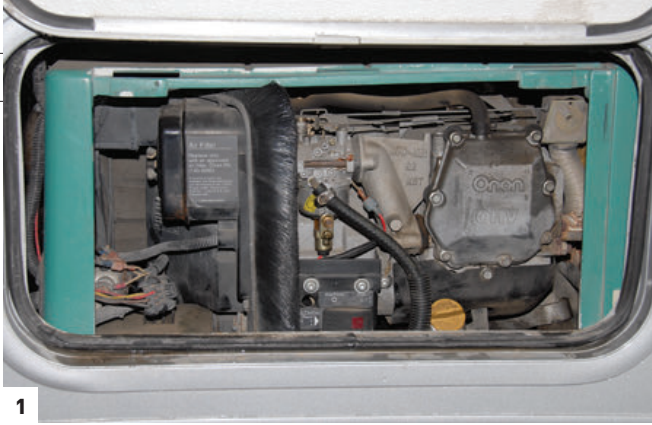

1



2



3



4

at some point the generator may cease to function altogether, at which point it may no longer be worth the investment to repair it. A new replacement generator is the obvious solution — and while not inexpensive, the good news is the job can be done yourself with common hand tools and some mechanical/electrical experience. It's worth mentioning here that if you don't feel confident taking on a job like this yourself, there's nothing RV repair shops hate more than completing a job that someone else started. So, when in doubt, contact a qualified dealer or RV repair center to determine costs.

We recently observed as an older Onan MicroQuiet 4000 generator was

[1] This Onan MicroQuiet 4000 generator had 1,456 hours on it, or roughly half of its normal life expectancy. Years of neglect finally took their toll, rendering this generator inoperable and unrepairable. [2] Replacement generators are readily available through Cummins Onan. This tag, located on every Onan/Cummins Onan generator, will tell the company everything it needs to know to provide you with the correct model. In this case, the original MicroQuiet 4000 would be replaced with a Cummins Onan RV QG 4000. [3] The first step is to pull the Weather-Pack connector to the remote control unit, which allows remote starting from the switch inside the motorhome. [4] Disconnect the battery cable after motorhome batteries have been disconnected.

replaced with a new Cummins Onan RV QG 4000 in a 2006 Fleetwood Tioga that had been purchased used, and was otherwise in excellent condition. The project was completed at C&S RV

Service Center in Oxnard, California, and took roughly four hours, but labor costs may vary depending on the motorhome and the complexity of the disassembly/installation.

[5, 6] Moving underneath the motorhome, disconnect the ground cable (arrow 1) followed by the fuel line (arrow 2). In most cases, the rubber fuel line is brittle and difficult to remove, so it will likely be easier to cut it off. The technician used an old spark plug in the line after it was cut to prevent fuel from dripping. [7] This older motorhome was not equipped with a transfer switch, so the next step was to disassemble and remove the junction box in a cargo compartment adjacent to the generator. [8] Removing four screws releases the cover, revealing the wiring inside. Use a screwdriver to release the white and black wires from the cover.



5



6



7



8

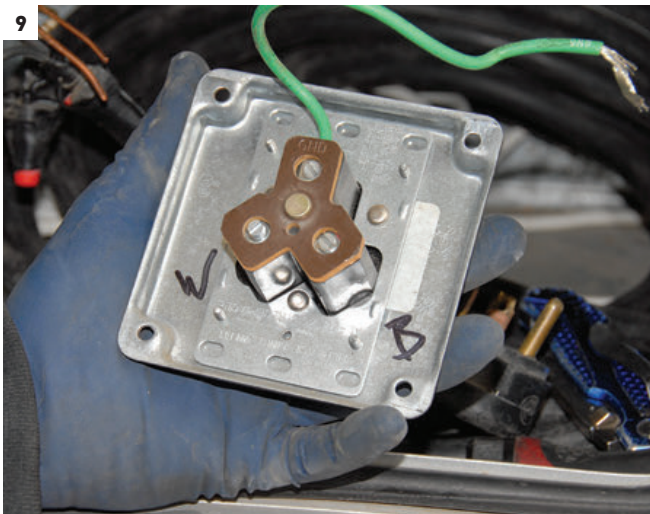

[9] A useful tip is to mark the inside of the cover so you know where the wires go on reassembly: W for white, B for black; the green ground wire remains attached. [10] Next, the exhaust pipe was removed. [11] A common floor jack and a square piece of plywood are used to support the generator prior to removal of the mounting brackets. [12] How the generator is mounted at the factory will depend on the motorhome, but in the case of this 2006 Fleetwood Tioga Class C, it is seated in a metal pan that is secured on either side by a mounting bracket and two bolts.



[13, 14] Next, the mounting brackets themselves are removed from the subframe, and the generator can be lowered to the ground. [15] Because the new generator does not come with wiring conduit and its attendant hardware, it is removed from the original unit. The 90-degree fitting is removed first and the conduit slid off. The wires from the new generator are then taped together, fed through the conduit and the fitting replaced. [16] The floor jack is once again employed to lift the new generator in place, and the disassembly procedure is reversed.





17



18



19



20

[17] Every Cummins Onan generator comes from the factory filled with oil. However, it's a good idea to check the dipstick before running, just to be sure. [18] Next, this rocker switch is used to prime the fuel pump, after which it is clicked to the right to start the generator. [19] After the new generator was installed, it was discovered that the original exhaust pipe bracket was broken. If not properly supported, vibration will eventually cause the pipe to crack and fail, so it was replaced with a new rubberized bracket. [20] Finally, a circuit tester is used in a 120-volt AC outlet inside the motorhome to make sure the generator was installed properly and is working correctly. 

Sources

Cummins Power Generation
800-888-6626,
www.power.cummins.com

C&S RV Service Center
805-983-1673,
www.candsrv.com

DRIVE THE LEGEND.

PREMIUM COMFORT & HANDLING.



BILSTEIN B6

- COMFITRACT™ piston technology reduces road harshness and increases vehicle control through unexpected obstacles
- Eliminates excessive sway and bounce for overall vehicle stability
- Maintains a safe, smooth and comfortable ride

For truck/towing applications:



B6 4600



B8 5100
(Ride Height Adjustable)



Good Sam Finance Center

Questions & Answers



Now is the time to purchase a new or used RV or refinance your existing RV loan. Check out some of our frequently asked questions to see how the Good Sam Finance Center can get you out on the road!

Is refinancing at a good rate still possible?

Yes! Now may be a good time to refinance your current RV loan and lower your monthly payments. And remember, our loans have no pre-payment penalties if you decide to pay the loan off early.

Do you finance private party RV loans?

Yes! You can purchase a 2006 model year or newer rig from a private party seller in your town or from across the country. We'll pay off the seller, put the new registration in your name and handle all necessary paperwork.

I'm a Full-Timer. Can I get financing for my RV?

Yes! Good Sam Finance Center offers financing to purchase or refinance the perfect RV to call home.

How do I know I'm getting a good rate?

We offer a range of loan terms from five to 20 years, depending on the loan amount and age of the RV. Our short term loans with lower rates have become popular, helping customers pay off their loans more quickly.

Are your rates the same for new and used RV purchases?

Yes! Our rates are the same whether you purchase a new or 2006 model year or newer used rig from a dealer or a private party seller across town or across the country.



APRs* AS LOW AS

3.99%**

on loan amounts of \$50k+

4.59%**

on loan amounts of \$25k to \$49,999

5.59%**

on loan amounts of \$15k to \$24,999

APR is fixed for the life of the loan. Other rates with different loan terms are available. Rates are accurate as of April 21, 2017. See our website for current rates and terms, as well as financing for Full-Timers and loan amounts below \$15,000.

CALL

1-800-444-1476
mention priority code 466

VISIT

GoodSamRVLoans.com/466



Good Sam
RV Loans

*Estimated APR (Annual Percentage Rate). Subject to consumer loan program requirements and credit approval. Certain fees, closing costs, and restrictions may apply.

** Rates and terms may vary with market conditions and are subject to change without notice. APR applied to the loan is the APR in effect on the date the application is received and is valid until 30 days after the loan is approved. APRs may vary with loan term. RV must be 2006 model year or newer; for RV model year 2006 to 2007, add .25% to above rate. Maximum loan amount is calculated using an advance percentage determined by FICO score and multiplied by 110% of NADA base wholesale value. Maximum loan term is based loan amount. Example of a recreational use RV loan: A 7 year fixed-rate \$55,000 loan. Based on an APR of 3.99%, this loan has 84 monthly payments of \$751.53 each.

Good Sam Finance Center™ provided through Essex Credit, a division of Bank of the West. In South Dakota, Bank of the West operates as Bank of the West California. NMLS ID #19116. Member FDIC.

©2017 Good Sam Finance Center. GOOD SAM and the GOOD SAM ICON are registered trademarks of Good Sam Enterprises, LLC.

Unauthorized use of any of GSE, LLC's trademarks is expressly prohibited. All rights reserved GRL52684 - 0417



EQUAL HOUSING LENDER



Negotiating narrow streets and parking lots on location can sometimes be difficult, but the Leahys love their Bounder.

ROCK 'N' ROLL RVING

A 2009 FLEETWOOD BOUNDER 38P ACTS AS HOME BASE FOR A COUPLE'S PRODUCTION COMPANY THAT HOSTS SOME TRUE STAR POWER

This article is the next in our series looking at motorhomes that have stood the test of time and can still make dreams come true. Each has earned the right to be called "the classic ride."

What if your motorhome financed your vacation? Throughout our search for classic coaches we have seen units of all sizes, each with unique properties that make it the perfect RV for its satisfied owners. But we have never seen a motorhome that literally pays for itself — that is, until we met Brian and Nancy Leahy at a campground in Marathon, Florida, and took a tour of their 2009 Fleetwood Bounder.

"Garth Brooks sat right where you're sitting," Brian points out when I take a chair.

The iconic country singer is not the only famous celebrity to cross this Bounder's threshold. The couple has hosted models, sports stars, music legends such as Sheryl Crow and the Doobie Brothers, and even comedian Jay Leno.

That is because the Leahys'

coach is more than just a vacation home-on-wheels — it is also the flagship vehicle of Rockstar Location Production Services.

The concept of building a business around an RV started with a producer friend, Renee, who was working a photo shoot with Nancy, a freelance custom seamstress. She suggested that Nancy and her husband, a musician and concert promoter with a background in set design, had the perfect personalities and skill sets to start their own location production services company.

"Every time you see a photo in a magazine with a model or a celebrity, there is a motorhome nearby — for makeup, changing, dressing and a place to rest, and for producers to set up computers and use as a mobile office," Brian explains.

In researching the concept,



Brian and Nancy Leahy at home in their Bounder, which doubles as the basis of their mobile business as well.

Brian discovered that many large national retailers, from Kohl's to Bon Ton and Lands' End to American Girl, schedule their catalog and advertising shoots near the couple's Wisconsin home. He also found that only one other organization existed locally to provide the services that those shoots required. Building a business around a motorhome had an added bonus — when the Leahys weren't working with models and celebrities, they could use their RV to go camping. This particularly appealed to Nancy, who had grown up vacationing in her parents' Winnebago.

The Classic Ride

Convinced now that they had the knowledge and contacts to be successful, they set off looking for the right motorhome. Size, an open floorplan and storage were the top priorities. After doing some online research, the couple went to see a 38P Fleetwood Bounder in Davenport, Iowa.

"It was the first RV we looked at, and we bought it," Brian says with a smile.

Fleetwood, a company with more than a half-century of experience in the RV industry, is known for introducing key innovations like basement storage and full-wall slide technology. A leading manufacturer of Class A and Class C motorhomes, Fleetwood is the home of both the iconic Discovery and the Bounder, both recognized for their workmanship and durability. In fact, according to IHS Automotive, there are more Fleetwood motorhomes on the road today than those by any other manufacturer. For its dependability alone, a Bounder was a good choice for the Leahys' fledgling business.

This particular Bounder also met all of their criteria and more. With a full-wall and standard slide in the living room and a third slideout in the bedroom, the coach offered the open floor space necessary for providing location services. The split bath allowed for optimal use of the facilities, and the large rear bedroom was roomy enough to serve as a wardrobe and changing area. Most importantly, the unit's cherry-finished cabinetry concealed an impressive 184 cubic feet of interior storage area, including full-extension drawers, along with a 12-cubic-foot refrigerator and a washer/dryer — all essential elements if the Bounder was going to do double



Clockwise, from top left: The space-saving dinette table can double as a desk, or fold flat to provide more comfortable seating. The well-equipped galley can easily support food preparation for a family or a film crew. The Bounder's expansive living space provides plenty of room for models to get their makeup applied. The Leahys always make sure to have their fridge packed.

duty as a mobile dressing room and a vacation home.

The Bounder's basement space also played a part in the couple's decision. A lighted luggage section, pass-through storage for large items, and compartments that moved with the living room slideouts were all features that made retrieving things easier. Another plus was the 20-foot exterior awning, large enough to provide shady seating for a sizable crew. Finally, the Bounder's exterior full-body DuPont paint was in excellent condition. With just 9,000 miles on the Ford V-10 Triton engine and a negotiated price tag of \$81,300, the 4-year-old Bounder seemed tailor-made for the Leahys and, in 2013, Rockstar Location

Production Services was born.

Preparing the Bounder for business meant temporarily losing some of the typical creature comforts. In order for the bedroom to serve as a fitting room for modeling shoots, the queen-size bed would have to go. The Leahys also purchased two professional makeup chairs to replace the reclining chairs in the living room, had mirrors fitted for the windows and added special lighting. But by far the biggest endeavor was choosing and purchasing all of the equipment — banquet tables, rolling clothes racks and ladders, all the way down to duct tape and drinking straws.

"The question we have to be prepared for is, 'Do you have blank?'"

BOUNDER ON THE BRAIN?

While you may not have the skill set to start a location production services company, a Fleetwood Bounder is a good buy for whatever adventure you have in mind. Bounders have been manufactured for more than three decades, a testament to their enduring popularity. The 38P Fleetwood Bounder was available in 2009 with a Triton 6.8-liter V-10 or Vortec 8.1-liter V-8 engine for a list price just under \$150,000, but can be picked up today on the used market for between \$65,000-\$75,000.

▶ The Fleetwood Bounder sports long-lasting two-stage DuPont full-body paint.



Nancy explains. "Whatever it is, we always want to be able to say yes."

The couple's business took off, in large part due to their experience and connections within the fashion and entertainment industries. Renee, whose suggestion started it all, hired Rockstar for three weeks in Illinois for Sears and Kmart, offering the kick-start they needed.

The Bounder also played a valuable role.

"Clients come in and they are always pleased with just how much room they have," Brian observes.

Brian also provides craft services, including special foods, drinks and gourmet snacks for their clients. He has been pleased with the well-appointed galley, with its three-burner stovetop and oven, double sink and slide-out countertop extension.

"I can really make everything here," he notes.

It may sound glamorous to rub elbows with the stars, but Brian is quick to point out that he sees himself as nothing more than a glorified host, mechanic, bus driver, chef, concierge and janitor. The couple works around 60 dates per year, each involving lengthy preparation, setup and breakdown in the days before and after they are on location. It is no wonder, then, that while the business became established very quickly, the anticipated camping experience was a little slower in coming. After several busy years, they finally decided they needed to "book out" a month and get some recreation out of their recreational vehicle. This meant reoutfitting the Bounder for travel. In addition to storing items like the dozen director's chairs, Brian made a deck in the "wardrobe room" to accommodate a tall inflatable mattress. He also took out the mirrors and makeup chairs, replacing them with the original ultra-leather recliners. Otherwise, the Bounder was ready to go.

When we met the couple in mid-January, they had already packed

Bounder co-owner Brian Leahy poses on location with comedian Jay Leno.

a lot into their first camping trip, visiting Mammoth Cave and Savannah, meeting children and grandchildren in Orlando for a visit to Disney, and sightseeing on Sanibel Island and along the Space Coast. They agreed that the same spaciousness that makes the 38P Bounder successful for location production services also makes it comfortable for long recreational trips.

"There really isn't anything I'd change," Brian says, though he notes that negotiating narrow streets and parking lots with a large Class A can be a challenge. The couple had already decided to add a dinghy vehicle on their next trip to make getting around a little easier.

After the Keys, Brian and Nancy were planning to travel to Florida's Gulf side and then move on to Nashville before heading home. Of course, when your RV is your family business, even vacation can't be "no work and all fun."

"Let me put it this way," Brian says. "We didn't make any money on this trip, but we did visit a client in Miami Beach. Need we say more?"

Both admit they are people who "can't sit still," making an RV lifestyle that mixes business and pleasure a good fit.

"We are going for the adventure, to see and do things we haven't before," Nancy adds.

And they have the perfect motorhome to do it. Living up to the challenges of both work and play, this versatile 2009 Fleetwood Bounder has earned its place as a classic ride. **M**



Steinbring Motorcoach
An Award Winning Newmar Dealer

Great Prices!

Knowledgeable Sales People!
New Friends!
Award Winning
Service Department!

*Celebrating
100 years!*
1917-2017



**Newmar Corporation
Prestigious Awards**



Top 10 Newmar Dealer

**Newmar Mahlon Miller Service
Excellence Award Winner**

**Newmar Customer Satisfaction
Excellence Award Winner**

**Newmar New Coach Delivery
Excellence Award Winner**

 Since 1917
**Steinbring™
MOTORCOACH**

Garfield, MN

Your International Newmar Dealer

STEINBRING MOTORCOACH

Toll Free 1.877.880.8090 | 320.834.6333

View inventory at: www.steinbring.com

Steinbring Motorcoach, Circle 149 on Reader Service Card

Rack 'Em

I needed a way to add some temporary “catch-all” shelves to improve the storage space in my Class B motorhome while at the RV park. I purchased canvas shoe shelves, the kind with 10 pockets, and hang the shelves from a capped shower rod in the space between the pilot and co-pilot seats while in camp. It's great for holding small electronics, maps, books, or anything not too heavy that will fit. When I'm ready to break camp, I remove the rod and hang the rack on the rod in the shower/tub area.

Jack Pearson | Anaheim, California



How Cool Is That?

We have always been concerned about our refrigerator's interior temperature, especially while boondocking. After installing a residential model, we wanted to monitor the interior temperature at a glance. So, my husband placed the outside remote sender of our indoor-outdoor thermometer on a shelf inside the fridge. The monitor was mounted in an easy-to-read location on the wall. Now all we do is look at the monitor hanging on our wall and we know the refrigerator's interior temperature without opening the door. Rather than spending thousands on a new fridge that displays the temperature in the door, you can buy a digital thermometer almost anywhere for around \$20.

Jean Green | Ash Flat, Arkansas



Foam Foler

As a longtime RVer I have learned that diesel fuel foams (or blows back if there is no auto stop). To help with the resulting mess, I take a full-size paper towel and fold it over from the top about 1 inch and continue until there is a 1-inch-wide folded paper towel. Wrap this around the end of the nozzle closest to the handle. Then when you insert the fuel nozzle it will stop at the end with the paper towel wrapping, ready to catch the foamed/blown-back diesel fuel before it runs down the side of the coach. It works every time.

John Merlet | Winter Park, Florida



Have an Idea?

Quick Tips is looking for submissions. Please send your DIY ideas to: *MotorHome* Quick Tips, 2750 Park View Ct., Ste. 240, Oxnard, CA 93036, or email letters@motorhomemagazine.com. Be sure to include any photos, illustrations or drawings. If your tip is selected for publication, you will receive \$35. All payments require an FEIN or SSN.

Great TV on the Road— *Whenever & Wherever* You Want!



Small footprint is perfect for RV living!

HBO
INCLUDED FOR 3 MONTHS*
with activation of DISH Pay-As-You-Go programming.

Enjoy DISH® Pay-As-You-Go Programming with the Wally Receiver!

DISH Wally® HD Satellite Receiver #87758 **Club SALE \$84.97** Reg. \$129

USER-FRIENDLY FEATURES!

- Works with any DISH® satellite antenna to bring you Pay-As-You-Go Programming
- Radio frequency remote can be used inside or outside the RV, through the wall up to 200 ft. away
- Locate your missing remote with the remote finder
- Easy access to your favorite apps and streaming content like Netflix (requires streaming membership and Wi-Fi Adapter)
- Additional Wally™ accessories available including: Bluetooth adapter and headphones, Wi-Fi adapter and additional remotes

With DISH® Pay-As-You-Go programming:**

- Pay only for the months you use
- Compatible with all DISH-specific antennas and most mobile satellite antennas
- Only DISH lets you watch your favorite shows in HD
- No charge to start or stop monthly service
- Programming for as little as \$34.99 per month!

Hurry, offer expires July 9, 2017. Call Camping World at 1.877.793.4801 to activate your DISH programming!

*After 3 months you will be billed \$15/mo unless you call to cancel. HBO® and related channels and service marks are the property of Home Box Office, Inc.

**Important Terms and Conditions: All prices, fees, charges, packages, programming, features, functionality and offers subject to change without notice.

Installation/Equipment Requirements: Monthly fees and limits on number and type of receivers will apply. All charges, including monthly programming, pay-per-view and equipment upgrades, must be paid in advance; failure to pay by due date will lead to service disconnection within 24 hours. Miscellaneous: Offers available for new and qualified former customers. Offers subject to terms of applicable Promotional and Residential Customer agreements. Taxes or reimbursement charges for state gross earnings taxes may apply. Additional restrictions may apply.



CAMPING WORLD®

SuperCenters Nationwide | 1.877.793.4801 | CampingWorld.com



Dish, Circle 110 on Reader Service Card

CW09084_0771.MHTL

Fabric Foibles

Feeling unstitched when a motorhome manufacturer initially refused to cover the entire cost of reupholstering the seats in a 5-year-old coach due to what he thinks is inferior materials, a reader contacted Hot Line for help. He wrote:



“ We own a 2011 Tiffin Allegro Open Road, which we purchased new. We are not frequent travelers; consequently, the coach is not very used, and only has approximately 18,000 miles on the odometer.

Generally, it has been a pleasure to own, but we feel there is one tremendous flaw with this RV: the fabric used on the chairs and couch. Considering the RV is used infrequently, we think the fabric is an inferior or a flawed product. In some places, the fabric has peeled away and, in certain areas, is literally falling apart.

We went through our dealer with this problem and they promptly notified Tiffin. Tiffin offered us new material with which to have our furniture re-covered. This did not remedy the problem since Tiffin sent the same inferior material to use (and only enough to cover one of the three seats). We are going to send the material back to Tiffin and request the \$183 they offered instead of the material, which isn't nearly enough to re-cover the chairs.

At our own expense, we had the arms of the side chair re-covered with a different material at an auto body shop. But we cannot afford to have the entire side chair or the front two captain's chairs re-covered. So this material is of no use to us.

Jerry Miller | Pensacola, Florida

Hot Line is a consumer-advocacy column, and we pride ourselves on helping out readers who feel they have been wronged. However, in this case, we feel that Tiffin actually went above and beyond its responsibilities in that the company offered any assistance at all for a coach that was more than 5 years old (and several years out of warranty).

We recognize the amount of fabric (and later the amount of money) offered is insubstantial when compared to the entire cost of reupholstering, but something is

better than nothing. After 5 years of even intermittent use, some components are bound to weaken or even fail. That includes fabric, which will often peel, crack or rip after nearly 2,000 days have passed. We passed along Miller's concerns to Tiffin, and although we didn't hear

from the manufacturer, we did hear back from Miller, who pointed out that Tiffin was aware of the issues with the fabric but wouldn't offer any further assistance. He wrote:

“ We did take the \$183 check, but that in no way constitutes any satisfaction on our part — it was just the only offer made. Even more annoying than [Tiffin's] lack of concern for the devaluation of our motorhome is the fact that the company knew the material was subquality. They told us that they couldn't keep up with the demand for new coaches, so they had to get another vendor to help supply the material for the furniture. They are no longer using that vendor.

J.M.

We considered this matter closed until we heard back from Miller one last time. Turns out this case has an even happier ending, as Tiffin came through once again. Miller wrote:

“ The final outcome to our furniture issue was resolved last week when Mr. Bob Tiffin called us personally. In that conversation, Mr. Tiffin offered to re-cover the two front seats. We opted to purchase a new recliner and not have the one in the coach re-covered. This option was satisfactory to us and we will be traveling to Red Bay, Alabama, to have our chairs re-covered. We appreciate your helping with this issue and we appreciate Tiffin Motorhomes, and Mr. Tiffin especially, for a favorable resolution.

J.M. M

Take Action Contact Hot Line for Help

Hot Line assists in mediating conflicts between consumers and RV dealers and manufacturers, accessories suppliers and service providers. After exhausting all other resources, send typed letters to *MotorHome* Hot Line, 2750 Park View Court, Suite 240, Oxnard, CA 93036 and enclose copies of appropriate bills and correspondence, plus a self-addressed, stamped envelope. Selected letters will be edited and published unless otherwise requested.

SUMMER SIZZLER

GET MORE FOR YOUR MONEY WITH GOOD SAM ROADSIDE ASSISTANCE



GOOD SAM ROADSIDE ASSISTANCE received a top ranking for roadside assistance programs from **TopConsumerReviews.com**¹

FEATURES & BENEFITS	 Good Sam Auto & RV Roadside Assistance	AAA*
Unlimited Distance Towing to the Nearest Service Center	YES	NO
Member, Spouse, and Dependent Children Covered – FREE	YES	NO
RV, Autos, Boat Trailers, and Motorcycles Covered	YES	NO
Coverage in US, Canada, Mexico, Puerto Rico, and US Virgin Islands	YES	NO
Flat Tire Change and Roadside RV Tire Delivery	YES	NO
Certified RV technicians on staff and the nation's largest RV-specific dispatch network	YES	NO
	\$74.95** <small>\$117.95</small>	\$180 + \$76 <small>per additional driver</small>

Sign up NOW and save! LIMITED-TIME OFFER expires July 31, 2017!

Call: 800-293-5178

Click: GoodSamRoadside.com

*Price reflective of \$5 Auto Renewal Discount. Introductory rate available for new members only.

**Information obtained from AAA of Colorado Plus RV plan at Colorado.aaa.com on 4/5/2017.

¹According to TopConsumerReviews.com, available on TopConsumerReviews.com published on 9/22/2016.

Benefits and services provided by Americas Road & Travel Club, Inc. for Members residing in Alaska, Alabama, Utah, and Virginia, and by Affinity Road & Travel Club, LLC for Members residing in all other States. Note: All program benefits are subject to limitations set forth in the current Member Benefit Brochure which can be found at www.GoodSamRoadside.com/MBBs. © 2017 Good Sam Enterprises, LLC. GOOD SAM and the GOOD SAM ICON are registered trademarks of Good Sam Enterprises, LLC. Unauthorized use of any of Good Sam Enterprises, LLC's trademarks is expressly prohibited. All rights reserved. GRA52686-0317

By Ken Freund

Roof Vent Restoration

Q Is there a product or method for restoring the appearance of my roof vent covers? Over the years from exposure to sun, rain, grime, birds and tree sap, they're looking pretty nasty. I clean them frequently, but the residual spots only worsen.

Jim Moore | Huntington Beach, California

A Vent lids are easy to replace and, as long as you know the brand of vent, they can be found at most RV supply stores and Camping World. Check out the video on our YouTube channel that shows how simple replacing an old lid can be: <https://youtu.be/-smmmvWSt5E>. Airxcel — manufacturer of MaxxAir ventilation products — also offers the UniMaxx universal kit, which is designed to fit all roof vents.



Mystery Sound

Q I own a clean 2003 Winnebago Brave on a P-32 Workhorse chassis. I keep the motorhome well-maintained. Over the years I have made improvements and fixes to the autopark braking system and the overheating ignition-wire-harness issues, both of which are well-documented. In the spring of 2015 I noticed a fleeting raspy/scraping sound coming from the forward chassis. The sound only presents itself when the coach is rolling at about 35-40 MPH, regardless of accelerating or braking, or while rounding a curve or while running straight. It lasts a second or two at a time, and will repeat several times at that speed. I have checked the fender-well shields, brake-dust shields, suspension, air bags, jack springs, etc., but still cannot identify the cause. A local mechanic rode with me and guessed it may be the EGR pump kicking in — but I don't know much about that, and the noise can occur while going up a hill or especially when coasting at that speed, so it's likely not vacuum related.

The mystery noise will not occur when the RV is parked and running at any RPM. This will be the third year I am driving the coach with

this symptom, and I am concerned something will rear its ugly roadside head in the middle of nowhere. I have searched forums but have not been able to find anything solid for a fix. Can you please give me some specific ideas or things to check?

Joe Maniec | Bloomington, Indiana

A Without hearing this noise it's very difficult to troubleshoot, but I do have some ideas. If the noise is more dash-related, the problem could be with the dash air-conditioning and ventilation system. The engine's manifold vacuum is used to operate the servos for plenum doors, and owner complaints often center on the discharge airflow changing to defrost-air (the default position of the plenum door with a low vacuum). I've only heard of EGR pumps being used on turbodiesel engines to overcome the intake-manifold pressure during boost, and have not heard of such a system on a naturally aspirated gasoline engine such as yours. You might be hearing the noise from the air conditioner compressor clutch cycling. You can simply shut off the system and test drive the motorhome to see if the noise is still present. I suggest that you test drive with the interior engine cover removed and have a

mechanic ride along to listen (with a mechanic's stethoscope, if needed). Sometimes it helps to have assistants listen with their head out the window to determine if the noise is coming from the wheel-well area. I have seen motorhomes where gravel got trapped between the rotors and backing plates, and the resultant sounds varied and went away as the gravel wore down and fell out. I would also try shutting the engine off and coasting at that speed to see if the noise still exists, which would eliminate engine sources (keep in mind you'll lose steering and braking assists, and should only do this on a wide, straight, level empty road in a safe area). As a reminder, readers can submit short videos (and photos) along with questions and comments to this column. A video with sound could help with my diagnosis. I'd also like to hear from any readers who have encountered a similar problem to this and found a solution.

Tow-Rating Change

Q I would like to increase the tow rating on a 2004 Fleetwood Southwind 32VS motorhome from the current 500-pound hitch and 5,000-pound tow ratings. Can this be achieved by replacing the current

receiver with a heavier part? We would like to increase the hitch weight to about 700 pounds and the towing weight to around 8,000 pounds.

Charles Lupinek | Lafayette, Indiana

A You're probably not going to like my answer. The chassis manufacturer provides a gross vehicle weight rating (GVWR), which is the maximum weight that the fully loaded motorhome and chassis can weigh; and a gross combination weight rating (GCWR), which is the maximum weight that the fully loaded motorhome and chassis and any trailer or towed vehicle can weigh. These numbers are based on engineering designs and analysis and testing, and are limited by brakes, wheels, tires, cooling systems, springs, suspension components, chassis rails, engine and transmission capabilities, in addition to other factors. The builder rates and certifies the finished motorhome to have certain tow- and hitch-weight ratings. While there are higher rated receivers on the market, weight limitations are dependent on chassis structure and capabilities, mounting positions and leverage applied to the rear of the frame. Hence, the ratings are set by the manufacturers, and they cannot be arbitrarily raised without extensive testing and recertification, which is not practical.

Tire Cupping

In the March "Tire Cupping" letter, a reader discussed his concern about cupping at a very low mileage. I had a similar occurrence with my 2004 Newmar Dutch Star motorhome with severe front-tire cupping at approximately 50,000 miles. After replacing the Michelin tires, I took the coach to a truck repair shop for an alignment. It found that the front tires were in alignment; however, the rear axle was discovered to be slightly out of alignment, causing the coach to "crab" going down the road. They attributed the cupping to the rear-end misalignment, and stated this is not an uncommon occurrence. I've put 63,000

EXPERIENCE THE ULTIMATE IN BACKYARD GRILLING



28"L x 21"W x 25"H



Weber Q™ 1000
(Mfr. #50060001)

- 189 sq. in.
- Push-button ignition
- 8,500 BTU
- 23½"H x 27"W x 20¼"D

Weber Q® Portable Cart
(Mfr. #6557)

CW026806

ON SALE NOW for Good Sam Club Members
CampingWorld.com | 1.888.857.6625 | SuperCenters Nationwide

GOT A V10?

Does your RV look at a hill and shift?

WE CAN FIX IT!

Want better efficiency?

WE CAN IMPROVE IT!

See in depth article in *May 2016 Motorhome* page 111



www.5StarTuning.com
843.536.1244

5 Star Tuning, Circle 101 on Reader Service Card

h innovations
housing

16th-Annual Charity Raffle

WIN

a New Winnebago
Forza Motorhome

— or —

a Quarter of a Million Dollars in Cash!

All proceeds benefit Innovations Housing, a 501(c)(3) nonprofit organization that builds affordable homes for low-income families around the world.

Raffle monitored by Redwine & Tegerstrand, CPAs of Redding, CA. State of California, Department of Justice Raffle Registration Number R-173. Must be over 18 to enter. Void where prohibited. Winner need not be present to win.

Winner will take home a new 38-foot Winnebago Forza motorhome or \$250,000.00. Winner responsible for taxes, title and license.

To purchase tickets with a Visa, MasterCard, Discover or American Express call **+1 (800) 764-8096** toll free or **+1 (530) 243-5693**. or mail a check to Post Office Box 991846, Redding, CA 96099-1846, USA. For more information visit www.innovationshousing.org.

Tickets Only
\$100.00 Each

**No More Than 7,500
Tickets Will Be Sold**

Drawing Will Be
August 31st, 2017

COACH & POWERTRAIN

miles on the coach since then, and have not had the same problem arise.
Kurtis Kindschi | Merrimac, Wisconsin

Thanks for sharing your tip based on your experience, Kurt. It's easy to overlook rear-axle alignment, but it, too, can have an effect on tire wear and handling. The most common source of rear-axle misalignment with solid axles (non-independent suspension) on heavy vehicles is one (or both) broken leaf spring center bolt, which locate the axle to the springs. This allows the axle to shift location on the spring's main leaf.

Storage and Fuel

Q We have a 2012 Winnebago Vista with a Ford gas V-10 engine. Sometimes the rig is in storage for about three months. Should I use a fuel stabilizer such as Stabil? One RV tech told me that the new gasoline engines don't need a stabilizer.

Vincent Laubach | Reno, Nevada

A Gasoline reacts differently depending on its blend and storage conditions. So-called winter blends contain more volatile components to improve vaporization and help with cold starting at low temperatures. These blends are more volatile and tend to break down faster. Summer blends are less volatile because it helps reduce smog formation in certain urban areas (such as Las Vegas). A motorhome stored in the hot sun for three months during summer will have more chemical changes to the gasoline than one that's stored for three months in winter at subfreezing temperatures, which slow down chemical changes. Gasoline that contains ethanol (widely used in the U.S.) also deteriorates differently than straight gasoline. Moisture condenses in the tank from temperature changes, which also causes problems, especially when three months of storage turns into four or six months.

Older gasoline engines with carburetors do seem to be less tolerant of stale fuel than fuel-injected models. However, they can all gum up, and 10 sticking injectors can be costly to fix.

Innovations Housing, Circle 120 on Reader Service Card

**ENJOY
THE DRIVE.**

**UPGRADE
THE RIDE.**

**Are you tired of White
Knuckle Driving?**

**BRAZEL'S
RV
PERFORMANCE**



UltraRVProducts
.COM

We're Here for You, Please Call
800-417-4559

Order Parts Online:
www.URVP.com

Visit Our Facility:
www.BRAZELSRV.com

Brazel's RV Performance, Circle 103 on Reader Service Card

I've seen lots of jammed electric fuel pumps from gum deposits, too. And, don't forget the generator. Therefore, I recommend adding fuel stabilizers when you think your motorhome will sit idle for a while.

Generator Quits Due to Heat

We own a 2005 Itasca SunCruiser (gas model) with an Onan 5500 generator, which has consistently given good service. Prior to a long trip last summer, I had the genset serviced, and we headed east from Illinois in mid-August with the generator running and the basement A/C working well. Temperatures that day were in the mid-90s, and we got caught in heavy traffic in Indiana. Every time we had to stop, the generator stopped. Temperatures outside of the coach were reading above 105 degrees. Further, the dash A/C on the main engine would not kick on (we never used it, so I had not kept it charged properly). It got so hot in the coach we were afraid we would lose the dog. Once we got past the construction, the generator ran fine all of the way to Maine, even when it was hot, but only when we were moving. The shop that had serviced the unit told us later that because it was air cooled, the generator needed the coach to be moving in extremely hot weather, or it would overheat and stop running. Coming home the Onan ran fine, moving or stopped, but the weather was cooler. It's an important feature to understand; it took me about 35 years to figure out. (I've since had the main engine A/C charged as a backup, just in case.)

Alan Spear | Batavia, Illinois

Thanks for sharing your experience. Onan gensets are designed to shut off to protect them from overheating or a lack of oil (and of course will also shut off when the fuel in the tank gets down to below about 1/4). When you stop, the genset is picking up its airflow from the air just above the hot pavement, and also gets some hot air coming from the engine and exhaust system circulation under the motorhome. This intake

air temperature can often exceed 160 degrees in hot summer weather.

Battery Goes Dead When Disconnected

Regarding the "Battery Goes Dead When Disconnected" item in the April issue: We own a 2014 Thor Chateau 22U motorhome, and had the same problem when we picked it up new. The dealer spent two weeks trying to find a problem. The technicians said everything was working right. I contacted Thor and talked to a representative, and was told that there had been some trouble with the starting batteries going dead, so the backup camera and a couple of other items were moved to being powered by the house battery. I finally isolated the problem being caused by the chassis controlling items connected to the house battery. I realized that the items in question were left on (even if you can't see them on) unless the driver's



DAVE & LJ'S
RV INTERIOR DESIGN

THE NATIONS PREMIER
RV INTERIOR
REMODELING CENTER

Flexsteel
America's Seating Specialist

RV FURNITURE

FLEXSTEEL FURNITURE - FLAT SCREEN TV INSTALLATION
AUTO MOTION SHADES - RV FLOORING - CUSTOM CABINETS
Exit 21 Off I-5 Woodland, WA (360)225-7700

www.daveandljs.com

Dave & LJ RV Interiors, Circle 108 on Reader Service Card

Hook it up Yourself with a **WIRELESS CAMERA!**



iBALL 

Wireless Trailer Hitch Camera

- 100% Wireless & Portable
- Easy—Installs in Seconds!
- Magnetic & Submersible Camera
- Trailers (Boat, Camper, Horse, ATV, Livestock and More!)

Info/Buy Now: 1-877-298-2055 or
visit our website at:

\$169⁹⁵ w/Free US/CDN Shipping
SAVE \$30 Today! Use Promo Code HITCH30

www.iballhitchcam.com

iBall Hitch Cam, Circle 129 on Reader Service Card

Unique, Flat Adjustable German Beds for RVs

The Only Truly Flat Adjustable Bed
Starting at \$898!



Easy to Install & Access Storage!



Adjustable Frame is only 5" thick!

- ★ Place **Flat** on Platform
- ★ **No Holes** need to be cut in the platform

Normal Access To Storage With Short Frame Option

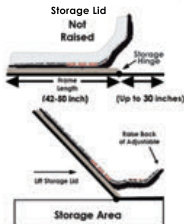

Call & Save \$100!



Senior, Veteran, Combo Discounts!



Steele RUBBER PRODUCTS

OVER 100 RV EXTRUSIONS AVAILABLE

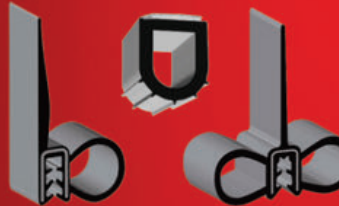

Call for your FREE RV Catalog

800-650-5137

www.steelerrubber.com

UltraRVProducts.COM



PLUG AND PLAY PERFORMANCE

- +60 HORSEPOWER
- +70 FT. LB. TORQUE
- IMPROVED SHIFTING!

UltraPower CUSTOM PROGRAMMING

CALL US!
800-417-4559

Free Shipping on Orders over \$100!

www.URVP.com

A NEW CHOICE

Replace your RV Refrigerator Cooling Unit with an ALL-NEW Replacement Cooling Unit

EASY-TO-INSTALL for the casual or experienced RVer

Ask us about our NEW Non-explosive HELIUM designed unit

Made in the USA

Get it factory installed or we can ship to your door!



Phone: (260) 768-4067

Fax: (260) 768-4424

www.jc-refrigeration.com

*jcref@centurylink.net



TireTraker™ Tire Pressure Monitoring Systems



TT-500

The Most Innovative TPMS On The Market Today With A "Lifetime Warranty"

- Pressure & Temperature Monitoring
- USB Rechargeable Monitor
- Monitors Up To 22 Tires (0-232psi)
- 0.5 oz. Sensors - Lightest on Market
- User Replaceable Sensor Batteries
 - Visual & Audible Alarms
 - Automatic Update Feature

4 Sensor Systems

With Lifetime Warranty

\$289.00

Additional Sensors ~ \$35.00 ea.



866-200-9773
info@tiretraker.com
www.tiretraker.com

CalMark Cover Co. Since 1982 has your RV sunbrella® covered!



100% USA Made

FSR® Construction
Zipper Doors
Full 6 Year Warranty
100% Guarantee



- Highest UV Rated
- Water Resistant
- Breathable
- Mold/Mildew Resistant
- 100% Non Abrasive

sunbrella® Made by Glen Raven Mills
Best fabric for ALL weather conditions in USA & Canada

1-800-838-7236

calmarkcovers.com

info@calmarkcovers.com

Specializing in all types of RVs, Horse trailers & more!



MotorHome.com



The online resource for the RV enthusiast

BRAZELS RV PERFORMANCE PRODUCTS

AUTO PARK BRAKE GOT YOU DOWN?

We Manufacture Lifetime Warranty Parts that Protect Your Auto-Park Brake From Applying While in Motion!

AIR CONVERSION KITS AVAILABLE

UPGRADED:

- HYDRAULIC PUMPS
- PRESSURE SWITCHES
- HYDRAULIC ACTUATORS

TECHNICAL ASSISTANCE PROVIDED

877-786-1576

www.BRAZELSRV.com

door was opened and closed after the house-battery disconnect switch was turned off. I checked with the dealer technician, and he confirmed that he only went in and out using the driver's door. Since then I have not had any problem with the house battery going dead. I just make sure that I open and close the driver's door when I am leaving the unit parked.

Jim Barry | Fort Worth, Texas

Thanks for writing, Jim. I discussed this system directly with Thor's technical services, and was told that the disconnect switch only works on the coach batteries, not the engine-starting battery. So, circuits connected to the engine battery should still work. The battery-disconnect relay is only controlled by a switch, and there is no related circuit going to the driver's door, nor is there any sort of timer or delay. You might also consider adding an engine-battery disconnect just to be sure.

Fuel Overflow When Filling

I read the letter from Bobby Watson ("Overflow When Filling") in the April issue about his problem with overfilling/spillage or slow fill. I had the same problem with my Itasca Meridian until someone helped me with it. Some fuel hoses to the tank have bends that will create restrictions in the hose and cause very slow fill rates or, if the second (other side) fill cap is removed, it will spill because there is not enough back pressure to shut off the pump. A friend who also owned a Meridian told me to turn the nozzle 90 degrees when filling. In the two years since he told me this, I have not had a problem even at truck stops, which fill at a much higher rate than standard diesel pumps. I do not know if this is Watson's problem, but it may bear looking into. This was a very frustrating situation that is now solved. When I looked at the fill hose I saw that it was bent not far from the cap.

Rick Dugas | Baton Rouge, Louisiana

Very often this problem is created by hoses that are kinked or bent exces-



SULASTIC
RUBBER SPRINGS

SMOOTHER RIDE
just replace the stock shackles

Not-affected
Load Tow

Sulastic
OEM Shackles
Leaf Spring

www.sulastic.com

NEVER WAX AGAIN

Wildwood
Easy 2-step process. Wipe on, let dry. Looks like new, lasts over 12 months.

Restore and protect. No rubbing or buffing.

SEE our video demo on our website!
www.poliglowproducts.com
800-922-5013

GUARANTEED

Attaching your coax cable to the RV park power pedestal just got easier!

RV Cable Grip Kit with install tool
\$16.99 plus shipping

25' Coax Cable with grips included
\$28.99 plus shipping

Order Now at:
www.rvcablegrip.com

J WRIGHT CONCEPTS
RV Cable Grip
PATENT PENDING
J Wright Concepts PO Box 292511 Sacramento CA 95829
(916) 955-0048 cablegripguy@gmail.com www.rvcablegrip.com

USA ROADBAG

The Finest/Toughest Bikecover Built To Beat The Weather

- Made of 600D Canvas
- Call for Colors Available
- 3 Sizes Available
- Made in the USA

USARoadbag.com
(208) 660-6351

MotorHome.com

DESTINATIONS

IDAHO

RVERS LOVE IDAHO!

- Great camping
- Less crowded, less expensive
- Amazing outdoor recreation
- Breathtaking scenery
- Friendly, helpful people

RV IDAHO 2013
IDAHO
visitidaho.org

FREE!
IDAHO RV Campground Directory

RVIdaho.org

Good Sam Club

Good Sam Club now offers even more money-saving reasons to join!

- Good Sam RV Park Camping Discounts
- Camping World Club Pricing
- Pilot Flying J Fuel, Propane & Dump Station Discounts
- Preferred Rates on Insurance and Roadside Assistance
- Plus Many More!

Join today at
GoodSamClub.com
or call
1.800.234.3450



sively, or a hose that has a low spot where fuel collects, which blocks flow and shuts off the pump. Moving the nozzle handle around and trying different positions can also solve some filling problems. Thanks for writing.

Battery Goes Dead When Disconnected, Part 2

We had exactly the same problem as noted in the "Battery Goes Dead When Disconnected" letter in the April issue. If Olson's Thor Chateau has an inverter, that may be the problem. We own a 2014 NeXus Viper, and the house batteries would go dead after a few days after turning the master power switch off when storing the RV. After talking extensively with the manufacturer, we discovered that the inverter is wired to the batteries outside of the master power switch. The inverter, even when turned off, is draining a small amount of power from the batteries. NeXus told us it wires all its inverters outside of the master power switch. We had NeXus install a shutoff switch for the inverter, the downside being that when you turn it back on you have to hit the reset button on the inverter. The easy fix is to just disconnect the battery cables when you store it.

Cheryl McCloskey | Prescott, Arizona

There are all sorts of parasitic electrical loads on motorhomes, and inverters are common among them. Alarms and entertainment equipment memories are among the culprits. You can detach a cable from the battery with everything supposedly shut off and measure current between the cable end and battery terminal with an ammeter to verify the existence of any loads. **M**

Have a Tech Question?

Contact our experts:

Email tech@motorhomemagazine.com or write to *MotorHome*, 2750 Park View Court, Suite 240, Oxnard, CA 93036 (please include your name, city and state). Selected letters will be answered in the magazine, but time does not permit individual replies.

ADVERTISERS INDEX		
RS #	ADVERTISER	PAGE #
101	5 Star Tuning.....	97
116	Banks Power.....	46
123	Bilstein Corporation	87
102	Blue Ox	47
118	BrakeBuddy	21
103	Brazel's RV Performance	98
104	Cal-Am Properties	107
	Camping World	60-61
	Camping World RV Sales	41
105	Carefree of Colorado	31
	Classifieds	103-105
	Coach House Inc.	49
113	Coachmen Pursuit	39
106	Custom Glass Solutions	13
147	DampRid Moisture Absorbers	76
108	Dave & LJ RV Interiors	99
109	Dethmers Manufacturing	34
110	DISH Network	93
111	EEZ RV Products.....	7
112	Fast Master Products.....	27
114	Foretravel	2
115	Furrion	71
117	Geico	55
	Good Sam Extended Service Plan	65
	Good Sam Roadside Assistance	95
	Good Sam RV Loans	88
	Good Sam RV Travel Guide	73
	Good Sam Travel Assist	75
	Good Sam Visa	50
	Harbor Freight Tools.....	83
119	HWH Corporation	35

ADVERTISERS INDEX		
RS #	ADVERTISER	PAGE #
129	iBall Hitch Cam	99
120	Innovations Housing	98
121	Jayco	29
122	King	48
143	Leisure Travel Vans	59
124	LiquidSprings	24
151	Mobile Communications	53
126	Newell Coach Corporation	108
127	Newmar Corporation.....	4-5
128	Nexus RV	7
130	Pala Casino Spa & Resort	17
131	Pleasure Way	45
132	Riverside Resort & Casino.....	9
133	Roadmaster, Inc.	11
134	RV Armor, Inc.	36
	RV Marketplace	100-101
135	RV Roofing Solutions	28
136	RV World of Nokomis	37
107	RVibrake by Danko Mfg.	82
137	RVRoof.com	20
125	RVT.com	12
138	Sea Eagle	10
139	SMI Manufacturing	14
140	Source Engineering	40
150	Steinbring Motorcoach	34
149	Steinbring Motorcoach	91
141	Theftford Corporation	77
142	Thor Industries	67
144	Vogt RV Center	30
145	Walex	38
	Weber	97
146	Winnebago Industries.....	19
148	Xantrex.....	27

While every effort is made to maintain accuracy and completeness, last-minute changes may occasionally result in omissions or errors.

ACCESSORIES

Hard To Find RV Wipers-2 Screw Bayonet Mount

Available in 26" & 28" Call 855-LUBEUDO or Order Online at www.LubeUDo.com
Don't Overpay ~ Do it yourself and SAVE!

LEAKY ROOF? Liquid Roof® goes on like paint --

cures to a sealed EPDM rubber membrane. UV & Ozone resistant--good to 300° F. 5-year warranty. 800-467-7135 www.AdvancedRubberCoatings.com

Ventilation for electronics and closets

Automatic temperature or manual control
Be cool & fresh - VERY quiet, EZ install
EZ2VENT.com 818-321-4115

CAMPGROUND MEMBERSHIPS FOR SALE

CAMPGROUND MEMBERSHIP OUTLET-SINCE 1991

To buy 800-272-0401
To sell 800-952-0401
Any Membership-Nationwide. Best prices ever.

For Sale: Personal resort membership

Private resorts located in the beautiful Black Hills of Western SD & historic bluff country in SE MN, offering many amenities & much more. Call 605-490-1295

HELP WANTED

HAVE THE BEST OF BOTH WORLDS – Combine

your RV Travel & Sales Experience. Good Sam needs highly qualified, self-motivated couples with proven sales experience in closing deals & selling intangible products. Couples will represent Good Sam RV Travel & Savings Guide & our digital assets as self-employed, independent contractors working on a commission based income. Meet face-to-face with customers selling print & digital advertising while gathering accurate data & applying Good Sam's criteria in evaluating RV parks & campgrounds & be in an assigned territory from Mid-Mar to Mid-Nov. Must be: Digital & tech savvy, proficient in Excel & Word, detail oriented, organized & have impeccable customer service skills. Email: MaryEllen.Foster@goodsam.com with your name, address, phone & include in the subject line: AC Desk MAG

NEED 3 CDL TRUCK DRIVERS FOR FRUIT hauling

8/10/17 to 10/29/17. Short hauls, long hours, good pay. Free RV site. Arrowhead Ranch, 610-E Jack Wells Rd., Bridgeport, WA 98813.

HOMES FOR SALE



Don't miss this beautiful 4 bedroom, 3 bath

home with an oversized 2 car garage on a huge 3/4 acre corner lot. Features include a 40x55 workshop with 14ft doors which incl. 15x40 carport to house your RV/Boat. Open floor concept with large Chef's kitchen with island, granite countertops, S/S appliances, plenty of cabinetry. Gas fireplace in living area. Enjoy your view of the lake from your large screened in pool patio. Offered at \$550,000. Contact: John A. King JKing@realtyking.com 772-473-6060



TOP RATED RESORT - S. Texas

Retama Village - Supersites \$50s.
RV Casitas \$120s RV Port Homes \$170s.
956-380-6500 www.bentsenpalm.com



Ultimate Priv RV Home - N. Georgia

Climate controlled RV Barn, 13+ ac, 8800+ sq. ft. house. 3-12'x14' garage drs & 2 wash racks. \$2.8m. Call Alex 678-642-8227 for info & pics



LILY LAKE GOLF RESORT - FROSTPROOF, FLA

- Manufactured Home Lots, RV Port Lots
- New Home/Lot Packages from the \$120s
- 1-863-635-3685. www.lilylake.com



#1 RATED RV RESORTS - S. Texas

Bentsen Palm Village & Retama Village
Rentals available for Pull-throughs,
Back ins, Super sites, and Casitas

956-585-5568 www.bentsenpalm.com

LOTS FOR SALE



NAPLES, FL-Crystal Lake RV Resort-FOR SALE:

1) RV Lot (Cement Foundation): \$120K Full Hook ups w/Shed incl Shower, Toilet, W/D.
2) Mobile Home (2Bd/Ba): \$259K Large Great Room w/nice size Kitchen, Jacuzzi in Master Bath, W/D. Can sell as package or separate! Come enjoy the Sun & Beaches of SW Florida at an affordable price. Call Jon 239-682-2019 or email jon@jonmaines.com. A full service realtor.

#1 RV Lot! BEST SUMMER WEATHER on Pend

Oreille River, WA with dock permit. Club house/pool/spa/boat launch access. Power/sewer/electric/H2O/parking slab/storage shed! \$99,900 (30% down) or \$79,900 cash. #509-270-7416 Email: albyx3wsu@yahoo.com

MotorHome.com



The online resource for the RV enthusiast

SW Utah Land Owner may finance 2-adj

20 Acre parcels 1320x1320 #6-unimproved-H2O right-\$25,500 #7-Improved-power, phone, septic, H2O tank, well prmt, H2O rights, trailer 2-8x20 storage, RV Carport, good road, AG20 zoned/many uses including airstrip. \$42,500 Near Zion Brian Head BLM Hunting. 707-367-3583

MAIL FORWARDING SERVICES



Good Sam Mail Service

High Quality Mail Forwarding State-of-the-art

Acct Mgmt tools! Req scans for urgent letters & contents. Mail shipped on your sched. Auto obvious junk mail shredding. Unique phys address in FL. No State income tax. Plans as low as \$9/mo. 877-388-2753 • www.goodsammailservice.com

MAIL/MESSAGE SERVICES

AMERICAS MAILBOX Forwarding in SD/Low Rates

NO Wheel Tax/NO Sales/Income Tax/Save \$\$\$
NO Safety Insp/4-Season Campground & Hotel
We Scan Your Mail/Insurance/Ext Warranties
www.AmericasMailbox.com Call Us First!!

MOTORHOMES FOR SALE



-Adventure Starts Here!-

3 Locations in So. California! 800-961-4464

San Marcos-Off Hwy 78-Camping World
Accessory Store on Site.
Santee - Off Hwy 67 @ Riverford
Palm Desert - Off I-10 @ Washington St.
Over 400 Motorhomes & Towables!
HOLLANDRVCENTERS.COM

HOLLAND MOTOR HOMES - Michigan

Renegade Super C + Sprinter RV's
www.holland-motorhomes.com
800-221-7197

MotorHome.com
The online resource for the RV enthusiast

MOTORHOMES WANTED



\$ RV BUYERS OF AMERICA \$
WE BUY YEAR 2003 & NEWER DIESEL
& GAS • FREE NATIONWIDE PICKUP
TOLL FREE 1-888-782-8987
www.rvbuyersusa.com
WE WILL BEAT ANY DEALER PRICE

We'll Buy Your Motorhome

Cash paid today for your RV



Call today to see
how much your RV
might be worth

Contact Wes at 855-902-9118

*Will Buy Towables on West Coast

WANTED:

2003 & Newer Gas or Diesel
"A "B" or "C" Motorhomes

**INSTANT CASH
NATIONWIDE PICK-UP**



Contact Mike at
(509)994-0718

mmohondro@freedomrvusa.com

FAST CASH FOR 2002-2017
GAS OR DIESEL MOTOR HOMES.

Free pick up. No hassles.

SELL RV NOW

SellRVNow.com
1.800.607.9754

WE BUY LATE MODEL MOTORHOMES

- INSTANT CASH
- NATIONWIDE PICKUP



CALL JOE:
831-458-6166



WE BUY & SELL LUXURY MOTORHOMES.

Huge hand-picked inventory. MotorHomeFinders.com



VOGT RV NEEDS YOUR MOTORHOME

We need clean, late model motorhomes
Buy - Sell - Trade - Consign
vogtrv.com - (817) 831-4222

WANTED USED DIESELS

SPECIALIZING IN NEWMARS
NATIONWIDE PICKUP
(602) 421-3870

\$CASH \$TOP DOLLAR PAID for late-model motorhomes.

All makes and models.No hassles.
For instant cash call Keith Roy
(toll-free) at 1-888-227-4078, PEDATA RV CENTER.

I BUY MOTORHOMES

CALL GAVIN...Regardless of your payoff!
Get Paid in LESS than 48 hours.
I'll come to you...ANYTIME-ANYWHERE!!
NATIONWIDE 321-332-8410

NATIONWIDE RV BUYER

Searching for 2005 and newer Pre-Owned RVs
Call 303.717.0880 or topbuyer@rvbuyerswest.com
www.rvbuyerswest.com

NORTHEAST MOTORHOME WHOLESALER

Cash for your late model gas or
diesel motorhome. Will buy nationwide.
Toll free 866-803-6787 www.futuresrv.com

WANTED

Have Cash, Will Travel
2005 & newer gas & diesel coaches
2005 & newer toy hauler
www.rvgone.com
Nationwide Pick Up. Toll Free 1-800-669-1807

I BUY MOTORHOMES

CALL RALPH...Regardless of your payoff!
Get Paid in LESS than 48 hours.
I'll come to you...ANYTIME-ANYWHERE!!
NATIONWIDE 210-287-2628

We can sell your RV Fast & for the Highest Price

Florida's #1 Consignment RV Sales Center
Conveniently located on the Space Coast in
Titusville, FL. Pickup available. Visit us at
Eaglespriderv.com or call AI @ 321-383-4495

RECREATION VEHICLES FOR SALE



SELL YOUR RV ONLINE AT RVT.com!

Reach Millions of RV Buyers with a Free or Until Sold Ad.
80,000 RVs for Sale - By Owner and Dealer Listings.
RVT.com or call 1-877-705-0025

LIST YOUR RV FOR SALE, BUYERS WAITING

•••www.RVclearinghouse.com•••
WE WILL FINANCE YOUR RV BUYER
RVs of all types. Diesel, Gas, Trailers, 5ers, Toads
www.RVFINANCING.COM • Facebook.com/rvloans

RV FINANCING

THE ORIGINAL RV FINANCING ONLINE

LOW RATES, GREAT SERVICE, NATIONWIDE
1998 AND NEWER RVs ALL TYPES
www.RVFINANCING.COM • Facebook.com/rvloans
CALL NOW-toll free 888-929-4424

RV SPACES FOR RENT

LARGE RV SPACES 55+, Bellflower, CA

POOL, CLUBHOUSE, ACTIVITIES, WIFI
Website: rosewoodland.com/mhp
Rosewoodrvpark@gmail.com 562-867-3227

RV WARRANTIES

www.RVWARRANTY.COM

RV EXTENDED SERVICE CONTRACTS
Get your FREE quote here
www.RVWARRANTY.COM • Facebook.com/rvloans

SERVICES

Register your Vehicle & SAVE THOUSANDS

Avoid high licensing fees and sales tax

TAX FREE Montana Vehicle Registration

Assisting clients worldwide with Montana
vehicle registration for over 19 years.

Jared S. Heggen, Licensed Attorney
888-777-5032 | heggenlawoffice.com

HEGGEN
LAW OFFICE, P.C.
Attorney at Law

ALL DAY

\$49

MONTANA
REGISTERED
AGENT LLC

\$800 for a 1 day MT LLC and RV Registration

All fees incl. Plates in your hands in 3 days.
www.49dollarmontanaregisteredagent.com
Call for more info 406-552-0004.



NATIONWIDE WINDSHIELD REPLACEMENT SERVICE

Insurance claim specialists, OEM Glass
All makes and models, National warranty
\$100 off MobileRVGlass.com 855-778-4527

Let us help you BUY YOUR RV ... TAX FREE!
We guarantee BEST service and price
Receive \$100 Gas Card & FREE Mail Fwding
Call 888.430.3388 www.MontanaRV.net

ACTION SERVICES, LLC/WILSON LAW OFFICE

No Sales Tax in Montana. Consult a Licensed
Montana Attorney for an understanding of
LLC vehicle ownership. Call the Professionals
to get a comprehensive explanation.
800-481-0013 www.actionservices-mt.com

#1 IN SALES TAX SAVINGS

PAY NO SALES TAX! We have helped 1000's save
over the past 20 yrs. Call & talk to a CPA for
professional, friendly service! **www.rvtax.com**
Mountain States Consulting 800-565-4504

To avoid paying taxes,

There are laws you must know.
Thus, speak to an attorney,
Not a salesman who just wants your dough!
www.bennettlawofficepc.com 866-543-5803
Three Montana attorneys on staff.

TOURS



Guided RV Tours & Rallies

Lower 48 • Alaska • Canada • Mexico • Overseas
Free RV Vacation Catalog **844-872-7897** or
www.adventurecaravans.com



RV CARAVANS and RALLIES

Pre-Planned Routes, Expert Guides and
Safe Travel-North America & Overseas.
FantasyRVTours.com or call 800-952-8496

CLASSIFIED RATES

Display Classified Advertising Rate

1" ad B/W \$395
2" ad B/W \$675
Add \$75 for color.
Frequency discounts apply.

Optional Red Type

For your ad to appear in red type, add \$50
for Commercial ad, add \$25 for Private Party

Photos

For ad with picture, add \$65 (B/W or color
print acceptable; high-resolution digital
image preferred).
Limit one photo per ad.

How To Place An Ad

Submit ad copy by mail, email or fax.
Please include your name, address and
phone number. Mail: Send with payment
(check; money order; VISA, MC, Discover
or American Express number, signature
and expiration date) to:

MotorHome Classifieds
Attention: Katey Purgatorio
3431 S. 257th Street
Kent, WA 98032

Questions: Phone 847-229-6756

Email: katey.purgatorio@goodsam.com



Withdrawal Woes

Put pigskin privation in your rearview mirror at Canton, Ohio's Pro Football Hall of Fame Enshrinement Festival

By Alan Rider

Watching someone you care about going through NFL withdrawal is not a pretty thing. And nowhere is this truism more true than seeing hardcore football fans trying to white-knuckle it from the end of the big game in February to that first kickoff of the new season. Fortunately, their suffering is almost at its end.

That's because the small city of Canton, Ohio, is putting the finishing touches on what's technically called the Pro Football Hall of Fame Enshrinement Festival (www.profootballhoffestival.com; 800-533-4302). Those in the know, however, simply refer to it as Hall of Fame Weekend.

No matter what you call it, this four-daylong pigskin party an hour south of Cleveland gets underway on Thursday, August 3. The morning kicks off with a 3-mile human chain of area youngsters stretching to the Pro Football Hall of Fame, followed by an autograph session. The 2017 game between the Arizona Cardinals and Dallas Cowboys kicks off just after sunset (at 8 p.m. Eastern), with more autograph sessions designed to let you meet these and other past gridiron greats scheduled throughout the weekend. The official enshrinement ceremony for the seven new Hall of Fame honorees is on Saturday evening.

Now, I'll be the first to admit that Canton, Ohio, is not someplace that would ordinarily be on my list of top 10 motorhome destinations. Leading one

to rightly question what the National Football League was thinking when they located the Pro Football Hall of Fame here more than a half-century ago.

While the game of football traces its roots back to the late 1800s, organized leagues came and went until a group of Canton businessmen gathered together in a downtown automobile showroom to form the American Professional Football Association in 1920 (the organization would change its name to the National Football League two years later).

Today the Pro Football Hall of Fame (www.profootballhof.com; 330-456-8207) covers 118,000 square feet and is filled with remarkable memorabilia. My personal favorite sits in a nondescript glass case. It is a page out of what looks like an ordinary accounting ledger from November 12, 1892, showing that William "Pudge" Heffelfinger was

paid \$500 to play in that day's matchup between the Allegheny Athletic Association and Pittsburgh Athletic Club, thereby making him the world's first truly professional football player.

If you miss that surprising but easily overlooked historical artifact, not to worry. You'll have no trouble finding all the other expected relics that chronicle the development of the sport, from the rudimentary leather helmets and wool sweaterlike jerseys that once passed for uniforms to noteworthy pieces like the Oakland Raiders jersey that George Blanda wore during the last game of the 1975 season when he became the first player in NFL history to score 2,000 points.

Which is to say nothing of the positively blinding collection of more than four dozen jewel-encrusted Super Bowl rings, creations so coveted they've become nothing less than wearable trophies. And then there's the chance to get an up-close look at the league's grand prize itself, the simple sterling silver sculpture designed and produced by the folks at Tiffany's, better known as the Vince Lombardi Trophy.

Ultimately, of course, you could always sit in the comfort of your motorhome anywhere and just dial up the NFL's Hall of Fame game on the rooftop satellite dish. But, trust me on this, it's just not the same as being there. Which, when it comes right down to it, is the reason we're all out here, looking for that next dramatic place to touch down along The Road Ahead. **M**

“Watching someone you care about going through NFL withdrawal is not a pretty thing.”

Football's Finest

The 2016 Hall of Fame class included such greats as Tony Dungy (left) and Green Bay Packers legend Brett Favre, among others. The 2017 class will be inducted on August 5.



Photos: Courtesy Pro Football Hall of Fame

SUPERSTITION AT CANYON VISTAS VIEWS

BEAUTIFUL CUSTOM CASITAS
STILL AVAILABLE FOR \$119,900

LESS THAN 10 SITES LEFT!
CALL (888) 603-3415
or email shellyb@cal-am.com



————— And Introducing Our Stunning Neighbor: —————

MONTESA AT GOLD CANYON



Now featuring larger homes with available RV pads, Montesa at Gold Canyon is the perfect place to stay active, make long-lasting friendships and enjoy the life you deserve. Located at the foot of Superstition Mountain, you'll get lost in the serene panoramic views and the wide open spaces. With all we offer, you'll never run out of things to enjoy.

- Active-Adult Activities
- Billiards Room
- Ceramics
- Clubhouse
- Computer Lab
- Recreation Hall
- Fitness Center
- Pet Agility Area
- Pickleball
- Quilting & Sewing Room
- Shuffleboard
- Swimming Pool & Spa
- Tennis Courts
- Themed Parties
- Private Vista

CALL US TODAY
(888) 325-0936
TO BOOK A HOME AND COMMUNITY TOUR



MontesaHomes.com

Cal-Am Properties, Circle 104 on Reader Service Card

Luxury MEETS *Adventure*



NEWELL

Your Newell delivers the boldest, most extreme quality in every detail—from its power, performance and handling to its state-of-the-art design and materials.

The result: extreme luxury for every adventure.

To start your journey, visit newellcoach.com or call 1-888-3NEWELL