

# MULTI V™

## DUCTED INDOOR UNITS INSTALLATION MANUAL

### Mid Static Ducted Indoor Units



ARNU073M1A4    ARNU283M2A4  
 ARNU093M1A4    ARNU363M2A4  
 ARNU123M1A4    ARNU423M2A4  
 ARNU153M1A4    ARNU483M3A4  
 ARNU183M1A4    ARNU543M3A4  
 ARNU243M1A4

### High Static Ducted Indoor Units



ARNU363B8A4  
 ARNU423B8A4  
 ARNU483B8A4  
 ARNU763B8A4  
 ARNU963B8A4

### High Static Ducted Indoor Units



ARNU073M2A4  
 ARNU093M2A4  
 ARNU123M2A4  
 ARNU153M2A4  
 ARNU183M2A4  
 ARNU243M2A4  
 ARNU283M3A4

### Low-Static Ducted Indoor Units



ARNU073L1G4    ARNU153L2G4  
 ARNU093L1G4    ARNU183L2G4  
 ARNU123L2G4    ARNU243L3G4

### Vertical Air Handler Indoor Units

ARNU123NJA4  
 ARNU183NJA4  
 ARNU243NJA4  
 ARNU303NJA4  
 ARNU363NJA4  
 ARNU423NKA4  
 ARNU483NKA4  
 ARNU543NKA4



# PROPRIETARY DATA NOTICE

This document, as well as all reports, illustrations, data, information, and other materials are the property of LG Electronics U.S.A., Inc., and are disclosed by LG Electronics U.S.A., Inc., only in confidence.

*Do not throw away, destroy, or lose this manual.*

Please read carefully and store in a safe place for future reference.  
Content familiarity required for proper installation.

*The instructions included in this manual must be followed to prevent product malfunction, property damage, injury, or death to the user or other people. Incorrect operation due to ignoring any instructions will cause harm or damage. A summary of safety precautions begins on page 4.*

*For more technical materials such as submittals, engineering databooks, and catalogs, visit [www.lghvac.com](http://www.lghvac.com).*

For continual product development, LG Electronics U.S.A., Inc., reserves the right to change specifications without notice.

©LG Electronics U.S.A., Inc.

*This document, as well as all reports, illustrations, data, information, and other materials are the property of LG Electronics U.S.A., Inc.*

Safety Instructions .....	4	Refrigerant Piping .....	41
Introduction .....	9	Condensate Piping .....	45
Unit Nomenclature .....	11	Wiring .....	47
R410A Refrigerant .....	12	<i>General Information / Separating Wiring and Cables</i> .....	47
General Data .....	13	<i>Power Wiring / Communication Cable Connections</i> .....	48
<i>Specifications – High-Static M2 Chassis</i> .....	13	<i>Power Supply / Power Wiring Specifications</i> .....	49
<i>Specifications – High-Static M2 and M3 Chassis</i> .....	14	<i>Communications Cable Specifications</i> .....	50
<i>Specifications – High-Static B8 Chassis</i> .....	15	<i>Indoor Unit Communications Cable Connections</i> .....	53
<i>Specifications – Mid-Static M1 Chassis</i> .....	16	<i>Connection Procedure</i> .....	55
<i>Specifications – Mid-Static M2 Chassis</i> .....	17	<i>LGRED<sup>®</sup>, HRU Compatibility, and Gen 4 DIP Switch Settings</i> .....	57
<i>Specifications – Mid-Static M3 Chassis</i> .....	18	<i>Controller and Optional Wall-Mounted Sensor Installation</i> .....	58
<i>Specifications – Low-Static Ducted L1/L2/L3 Chassis</i> .....	19	<i>High-Static Ducted B8 Chassis</i> .....	59
<i>Specifications – Vertical Air Handler NJ Chassis</i> .....	20	<i>Mid-Static and High-Static Ducted M2 Chassis</i> .....	61
<i>Specifications – Vertical Air Handler NK Chassis</i> .....	21	<i>Mid-Static and High-Static Ducted M3 Chassis</i> .....	63
<i>Electrical – Mid and High-Static M1/M2/M3/B8 Chassis</i> .....	22	<i>Mid-Static Ducted M1 Chassis</i> .....	65
<i>Electrical – Low-Static Ducted L1/L2/L3 Chassis</i> .....	23	<i>Low-Static Ducted L1 Chassis</i> .....	67
<i>Electrical – Vertical Air Handling Unit NJ/NK Chassis</i> .....	24	<i>Low-Static Ducted L2/L3 Chassis</i> .....	69
<i>Dimensions – High-Static Ducted B8 Chassis</i> .....	25	<i>Vertical Air Handler NJ Chassis</i> .....	71
<i>Dimensions – Mid and High-Static Ducted M2 Chassis</i> .....	26	<i>Vertical Air Handler NK Chassis</i> .....	73
<i>Dimensions – Mid and High-Static Ducted M3 Chassis</i> .....	27	Controls Setup .....	75
<i>Dimensions – Mid-Static Ducted M1 Chassis</i> .....	28	Installation Checklist .....	80
<i>Dimensions – Low-Static Ducted L1/L2/L3 Chassis</i> .....	29		
<i>Dimensions – Vertical Air Handler NJ Chassis</i> .....	30		
<i>Dimensions – Vertical Air Handler NK Chassis</i> .....	31		
<i>Refrigerant Piping Diagrams</i> .....	32		
General Installation Guidelines .....	33		
Installation .....	34		
<i>Install Ducted IDU Chassis</i> .....	34		
<i>Indoor Unit Dimensions</i> .....	35		
<i>Duct Connection Dimensions</i> .....	36		
<i>Maintenance Clearances</i> .....	37		
<i>General Mounting - Vertical / Horizontal Air Handler Units</i> .....	38		
<i>General Mounting - Vertical / Horizontal Air Handler Units</i> .....	39		
<i>Piping Connections</i> .....	40		

The instructions below must be followed to prevent product malfunction, property damage, injury or death to the user or other people. Incorrect operation due to ignoring any instructions will cause harm or damage. The level of seriousness is classified by the symbols below.

## TABLE OF SYMBOLS

<b>DANGER</b>	<i>This symbol indicates an imminently hazardous situation which, if not avoided, will result in death or serious injury.</i>
<b>WARNING</b>	<i>This symbol indicates a potentially hazardous situation which, if not avoided, could result in death or serious injury.</i>
<b>CAUTION</b>	<i>This symbol indicates a potentially hazardous situation which, if not avoided, may result in minor or moderate injury.</i>
<b>Note:</b>	<i>This symbol Indicates situations that may result in equipment or property damage accidents only.</i>
	<i>This symbol indicates an action that should not be performed.</i>

## INSTALLATION

### **DANGER**

**Don't use or store flammable gas or combustibles near the unit.**

*There is risk of fire, explosion, and physical injury or death.*

### **WARNING**

**Do not install, remove, or re-install the unit by yourself (end-user). Ask the dealer or an LG trained service provider to install the unit.**

*Improper installation by the user may result in water leakage, fire, explosion, electric shock, physical injury or death.*

**For replacement of an installed unit, always contact an LG trained service provider.**

*There is risk of fire, electric shock, explosion, and physical injury or death.*

**Do not run the compressor with the service valves closed.**

*There is risk of explosion, physical injury, or death.*

**Periodically check that the outdoor unit is not damaged.**

*There is risk of explosion, physical injury, or death.*

**Replace all control box and panel covers.**

*If cover panels are not installed securely, dust, water and animals may enter the unit, causing fire, electric shock, and physical injury or death.*

**Always check for system refrigerant leaks after the unit has been installed or serviced.**

*Exposure to high concentration levels of refrigerant gas may lead to illness or death.*

**Do not install the unit using defective hanging, attaching, or mounting hardware.**

*There is risk of physical injury or death.*

**Wear protective gloves when handling equipment.**

*Sharp edges may cause personal injury.*

**Dispose of the packing materials safely.**

- *Packing materials, such as nails and other metal or wooden parts may cause puncture wounds or other injuries.*

- *Tear apart and throw away plastic packaging bags so that children may not play with them and risk suffocation and death.*

**Do not install the unit in any location exposed to open flame or extreme heat. Do not touch the unit with wet hands.**

*There is risk of fire, electric shock, explosion, and physical injury or death.*

**Install the unit considering the potential for earthquakes.**

*Improper installation may cause the unit to fall, resulting in physical injury or death.*

**Do not change the settings of the protection devices.**

*If the pressure switch, thermal switch, or other protection device is shorted and forced to operate improperly, or parts other than those specified by LG are used, there is risk of fire, electric shock, explosion, and physical injury or death.*

**If the air conditioner is installed in a small space, take measures to prevent the refrigerant concentration from exceeding safety limits in the event of a refrigerant leak.**

*Consult the latest edition of ASHRAE (American Society of Heating, Refrigerating, and Air Conditioning Engineers) Standard 15. If the refrigerant leaks and safety limits are exceeded, it could result in personal injuries or death from oxygen depletion.*

---



---

## INSTALLATION – CONTINUED

---

### **⚠ CAUTION**

**Be very careful when transporting the product.**

- Do not attempt to carry the product without assistance.
- Some products use polypropylene bands for packaging. Do not use polypropylene bands to lift the unit.
- Suspend the unit from the base at specified positions.
- Support the unit at a minimum of four points to avoid slippage from rigging apparatus.
- Failure to follow these directions may result in minor or moderate physical injury.

### **Note:**

**Properly insulate all cold surfaces to prevent “sweating.”**

*Cold surfaces such as uninsulated pipe can generate condensate that may drip and cause a slippery floor condition and/or water damage to walls.*

**When installing the unit in a hospital, mechanical room, or similar electromagnetic field (EMF) sensitive environment, provide sufficient protection against electrical noise.**

*Inverter equipment, power generators, high-frequency medical equipment, or radio communication equipment may cause the air conditioner to operate improperly. The unit may also affect such equipment by creating electrical noise that disturbs medical treatment or image broadcasting.*

**⊘ Do not use the product for special purposes such as preserving foods, works of art, wine coolers, or other precision air conditioning applications. This equipment is designed to provide comfort cooling and heating.**

*There is risk of property damage.*

**⊘ Do not make refrigerant substitutions. Use R410A only.**

*If a different refrigerant is used, or air mixes with original refrigerant, the unit will malfunction and become damaged.*

**⊘ Do not install the unit in a noise sensitive area.**

**When connecting refrigerant tubing, remember to allow for pipe expansion.**

*Improper piping may cause refrigerant leaks and system malfunction.*

**Take appropriate actions at the end of HVAC equipment life to recover, recycle, reclaim or destroy R410A refrigerant according to applicable U.S. Environmental Protection Agency (EPA) rules.**

**Periodically check that the outdoor unit is not damaged.**

*There is a risk of equipment damage.*

**Install the unit in a safe location where no one can step on or fall onto it. ⊘ Do not install the unit with defective hanging, attaching, or mounting hardware.**

*There is risk of unit and property damage.*

**Install the drain hose to ensure adequate drainage.**

*There is a risk of water leakage and property damage.*

**⊘ Don't store or use flammable gas/combustibles near the unit.**

*There is risk of product failure.*

**Always check for system refrigerant leaks after the unit has been installed or serviced.**

*Low refrigerant levels may cause product failure*

**⊘ Indoor units (IDUs) should not be placed in an environment where the IDUs may be exposed to harmful volatile organic compounds (VOCs), or in environments where there is improper air make up or supply or inadequate ventilation.**

*If there are concerns about VOCs in the environment where the IDUs are installed, proper air make up or supply and/or adequate ventilation should be provided. Additionally, in buildings where IDUs will be exposed to VOCs, consider a third party factory-applied epoxy coating to the fan coils for each IDU where the entire coil is dipped, not sprayed.*

---

---

## WIRING

### DANGER

High voltage electricity is required to operate this system. Adhere to the National Electrical Codes and these instructions when wiring.

*Improper connections and inadequate grounding can cause accidental injury or death.*

**Always ground the unit following local, state, and National Electrical Codes.**

**Turn the power off at the nearest disconnect before servicing the equipment.**

*Electric shock can cause physical injury or death.*

**Properly size all circuit breakers or fuses.**

*There is risk of fire, electric shock, explosion, physical injury or death.*

---

### WARNING

The information contained in this manual is intended for use by an industry-qualified, experienced, trained electrician familiar with the U.S. National Electric Code (NEC) who is equipped with the proper tools and test instruments.

*Failure to carefully read and follow all instructions in this manual can result in equipment malfunction, property damage, personal injury or death.*

**Ensure the unit is connected to a dedicated power source that provides adequate power.**

*If the power source capacity is inadequate or the electric work is not performed properly, it may result in fire, electric shock, physical injury or death.*

**Refer to local, state, and federal codes, and use power wires of sufficient current capacity and rating.**

*Wires that are too small may generate heat and cause a fire.*

**Secure all field wiring connections with appropriate wire strain relief.**

*Improperly securing wires will create undue stress on equipment power lugs. Inadequate connections may generate heat, cause a fire and physical injury or death.*

**Properly tighten all power connections.**

*Loose wiring may overheat at connection points, causing a fire, physical injury or death.*

---

### Note:

Do not cut, lengthen or shorten the communications and power cable between any dry contact unit and its connected indoor unit. Do not install the unit in a location where the communications and power cable cannot be safely and easily connected between the two units. Do not allow strain on this cable.

*Poor cable connections can cause equipment malfunction.*

---

## OPERATION

### ⚠ DANGER

⊘ Do not provide power to or operate the unit if it is flooded or submerged.

*There is risk of fire, electric shock, physical injury or death.*

**Use a dedicated power source for this product.**

*There is risk of fire, electric shock, physical injury or death.*

⊘ Do not operate the disconnect switch with wet hands.

*There is risk of fire, electric shock, physical injury or death.*

### ⚠ WARNING

⊘ Do not allow water, dirt, or animals to enter the unit.

*There is risk of unit failure, fire, electric shock, physical injury or death.*

**Avoid excessive cooling and periodically perform ventilation to the unit.**

*Inadequate ventilation is a health hazard.*

⊘ Do not touch refrigerant piping during or after operation.

*It can cause burns or frostbite.*

⊘ Do not operate the unit with the panel(s) or protective cover(s) removed; keep fingers and clothing away from moving parts.

*The rotating, hot, cold, and high-voltage parts of the unit can cause physical injury or death.*

**Periodically check power cable and connection for damage.**

*Cable must be replaced by the manufacturer, its service agent, or similar qualified persons in order to avoid physical injury and/or electric shock.*

**Securely attach the electrical cover to the unit.**

*Non-secured electrical covers can result in burns or electric shock due to dust or water in the service panel.*

### ⚠ CAUTION

**To avoid physical injury, use caution when cleaning or servicing the air conditioner.**

#### Note:

**Clean up the site after installation is finished, and check that no metal scraps, screws, or bits of wiring have been left inside or surrounding the unit.**

⊘ Do not use this equipment in mission critical or special-purpose applications such as preserving foods, works of art, wine coolers or refrigeration. This equipment is designed to provide comfort cooling and heating.

**Provide power to the compressor crankcase heaters at least six (6) hours before operation begins.**

*Starting operation with a cold compressor sump(s) may result in severe bearing damage to the compressor(s). Keep the power switch on during the operational season.*



**Periodically verify the hanging bolts and other hardware securing the unit have not deteriorated.**

*If the unit falls from its installed location, it can cause property damage, product failure, physical injury or death.*

**If refrigerant gas leaks out, ventilate the area before operating the unit.**

*If the unit is mounted in an enclosed, low-lying, or poorly ventilated area and the system develops a refrigerant leak, it may cause fire, electric shock, explosion, physical injury or death.*

⊘ Do not open the inlet grille of the unit during operation. Do not operate the unit with the panels or guards removed. Do not insert hands or other objects through the inlet or outlet when the unit is powered. Do not touch the electrostatic filter, if the unit includes one. The unit contains sharp, rotating, hot, and high voltage parts that can cause personal injury and/or electric shock.

**Ensure no power is connected to the unit other than as directed in this manual. Remove power from the unit before removing or servicing the unit.**

*There is risk of unit failure, fire, electric shock, physical injury or death.*

⊘ Do not open the inlet grille of the unit during operation. Do not operate the unit with the panels or guards removed. Do not insert hands or other objects through the inlet or outlet with the unit plugged in. Do not touch the electrostatic filter, if the unit includes one.

*The unit contains sharp, rotating, hot, and high voltage parts that can cause personal injury and/or electric shock.*

⊘ Do not block the inlet or outlet.

*Unit may malfunction.*

**Securely attach the electrical cover to the indoor unit. Non-secured covers can result in fire due to dust or water in the service panel.**

**Periodically verify the equipment mounts have not deteriorated.**

*If the base collapses, the unit could fall and cause property damage or product failure.*

⊘ Do not allow water, dirt, or animals to enter the unit.

*There is risk of unit failure.*





**Ducted Indoor Units**

This manual describes how to install LG ducted indoor units (IDU) for Multi V Variable Refrigerant Flow (VRF) heat pump and heat recovery systems. Table 1 lists the available models. Refer to LG’s Multi V Indoor Unit Engineering Manual for complete detailed engineering data and selection procedures.

**Safety**

Safety of personnel is the primary concern during all procedures. Read and understand the safety summary at the front of this manual. Read and understand this installation procedure before beginning installation. Use the appropriate tools and accessories during installation. Plan your work and do not work alone, if possible. Know how to obtain emergency medical and fire fighting assistance.

**Installation Personnel**

This equipment is intended for installation by personnel trained in the required construction, mechanical, electrical, and/or other disciplines.

**Applicable Codes**

Personnel must be familiar with and follow the applicable national, state, and/or local codes.

**⚠ WARNING**

*Installation work must be performed by trained personnel and in accordance with national wiring standards and all local or other applicable codes. Improper installation can result in fire, electric shock, physical injury, or death.*

**Note:**

*Please read all instructions before installing this product. Become familiar with the unit, its components and connections, and the order of installation. Incorrect installation can degrade or prevent proper operation.*

**Required Tools (field provided)**

- Level
- JIS screwdriver
- Electrical lineman pliers
- Electric drill
- Holesaw
- Drill
- R410A flaring tool set
- Tubing cutter
- Tube/pipe reamer
- Torque wrenches
- Allen wrench
- Refrigerant gas-leak detector
- Thermometer

**Required Parts (field provided)**

- Pipes - vapor line and liquid line, with insulation
- 3/8" or 1/2" nuts, flat washers, and lock/split washers
- 3/8" or 1/2" threaded hanger rods
- Insulated drain hose
- Additional drain hose
- Connecting cable (power and control)



Figure 1: High Static Ducted, B8 Chassis



Figure 2: High Static Ducted, M2/M3 Chassis



Figure 3: Mid Static Ducted, M1/M2/M3 Chassis



Figure 4: Low Static Ducted, L1/L2/L3 Chassis



Figure 5: Vertical Air Handling Unit, NK/NJ Chassis



Table 1: Multi V Ducted Indoor Units

Unit	Model Numbers		
<p>High-Static Ducted B8</p> 	<p>ARNU363B8A4</p> <p>ARNU423B8A4</p> <p>ARNU483B8A4</p> <p>ARNU763B8A4</p> <p>ARNU963B8A4</p>		
<p>High-Static Ducted M2/M3</p> 	ARNU073M2A4	ARNU243M2A4	
	ARNU093M2A4	ARNU283M3A4	
	ARNU123M2A4		
	ARNU153M2A4		
	ARNU183M2A4		
<p>Mid Static Ducted M1/M2/M3</p> 	ARNU073M1A4	ARNU183M1A4	ARNU423M2A4
	ARNU093M1A4	ARNU243M1A4	ARNU483M3A4
	ARNU123M1A4	ARNU283M2A4	ARNU543M3A4
	ARNU153M1A4	ARNU363M2A4	
<p>Low-Static Ducted L1/L2/L3</p> 	<p>ARNU073L1G4</p> <p>ARNU093L1G4</p> <p>ARNU123L2G4</p> <p>ARNU153L2G4</p> <p>ARNU183L2G4</p> <p>ARNU243L3G4</p>		
<p>Vertical Air Handler</p> 	<p>ARNU123NJA4</p> <p>ARNU183NJA4</p> <p>ARNU243NJA4</p> <p>ARNU303NJA4</p> <p>ARNU363NJA4</p> <p>ARNU423NKA4</p> <p>ARNU483NKA4</p> <p>ARNU543NKA4</p>		

**Cassette Indoor Units Nomenclature**

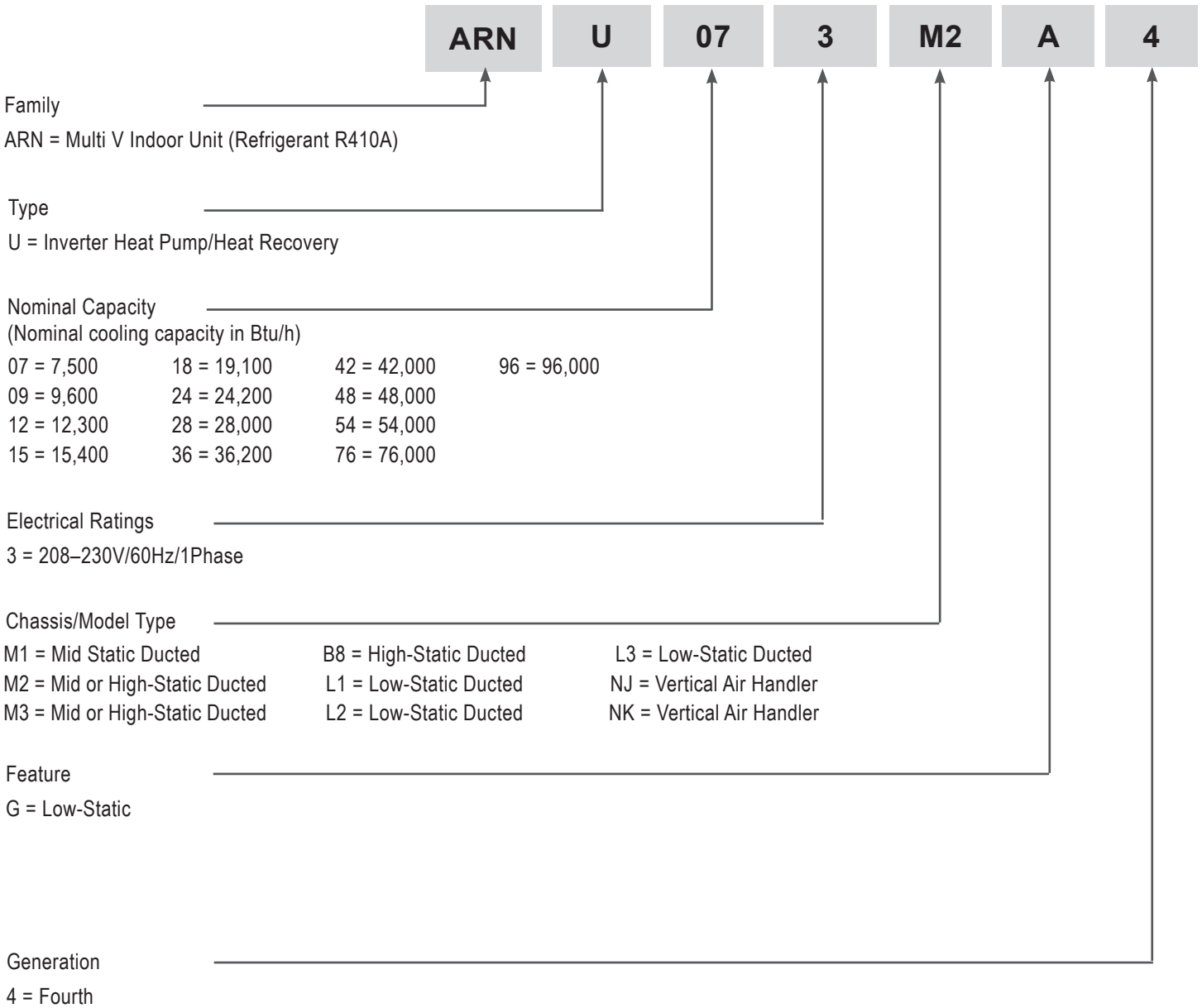

---

---

R410A refrigerant has a higher operating pressure in comparison to R22 refrigerant and, therefore, all piping system materials installed must have a higher resisting pressure than the materials traditionally used in R22 systems.

R410A refrigerant is an azeotrope of R32 and R125, mixed at 50:50, so the ozone depletion potential (ODP) is 0.

## **⚠ WARNING**

- *Do not place the refrigerant cylinder in direct sunlight. Refrigerant cylinder may explode causing severe injury or death.*

## **Note:**

- *Because R410A is a combination of R32 and R125, the required additional refrigerant must be charged in its liquid state. If the refrigerant is charged in its gaseous state, its composition changes and the system will not work properly.*
- *Do not heat piping more than necessary during installation. Piping may become soft and fail when pressurized.*
- *Do not use any piping that has not been approved for use in high-pressure refrigerant systems. Piping wall thickness must comply with the applicable local, state, and federal codes for the 551 psi design pressure of R410A. Inadequate piping may fail when pressurized.*

Table 2: Ducted High Static M2 Indoor Unit General Data.

Model No.	ARNU073M2A4	ARNU093M2A4	ARNU123M2A4	ARNU153M2A4	ARNU183M2A4
<b>Cooling Mode Performance</b>					
Capacity (Btu/h)	7,500	9,600	12,300	15,400	19,100
Max Power Input <sup>1</sup> (W)	430	430	430	430	430
L/M/H Power Input at Factory Default (W)	21 / 29 / 38	21 / 29 / 38	25 / 34 / 43	25 / 34 / 43	34 / 43 / 67
<b>Heating Mode Performance</b>					
Capacity (Btu/h)	8,500	10,900	13,600	17,100	21,500
Max Power Input <sup>1</sup> (W)	430	430	430	430	430
L/M/H Power Input at Factory Default (W)	21 / 29 / 38	21 / 29 / 38	25 / 34 / 43	25 / 34 / 43	34 / 43 / 67
<b>Entering Mixed Air</b>					
Cooling Max. (°F WB)	76	76	76	76	76
Heating Min. (°F DB) <sup>2</sup>	59	59	59	59	59
<b>Unit Data</b>					
Refrigerant Type <sup>3</sup>	R410A	R410A	R410A	R410A	R410A
Refrigerant Control	EEV	EEV	EEV	EEV	EEV
Sound Power <sup>4</sup> dB(A) (H/M/L, @0.24" ESP)	53 / 52 / 52	53 / 52 / 52	53 / 53 / 52	53 / 53 / 52	54 / 53 / 53
Net Unit Weight (lbs.)	82.9	82.9	82.9	82.9	82.9
Shipping Weight (lbs.)	95.5	95.5	95.5	95.5	95.5
Communication Cable <sup>5</sup> (No. x AWG)	2 x 18	2 x 18	2 x 18	2 x 18	2 x 18
<b>Fan</b>					
Type	Sirocco	Sirocco	Sirocco	Sirocco	Sirocco
Motor	1	1	1	1	1
Housing	2	2	2	2	2
Motor/Drive	Brushless Digitally Controlled / Direct				
Airflow Rate H/M/L (CFM) Standard Mode	477 / 399 / 327	477 / 399 / 327	520 / 435 / 363	520 / 435 / 363	640 / 520 / 435
Airflow Rate H/M/L (CFM) High Mode (Factory Set)	468 / 381 / 294	468 / 381 / 294	512 / 425 / 337	512 / 425 / 337	673 / 512 / 425
External Static Pressure (in. wg) Standard Mode	0.20	0.20	0.20	0.20	0.20
External Static Pressure (in. wg) High Mode (Factory Set)	0.24	0.24	0.24	0.24	0.24
<b>Piping</b>					
Liquid Line (in., O.D.)	1/4 Flare	1/4 Flare	1/4 Flare	1/4 Flare	1/4 Flare
Vapor Line (in., O.D.)	1/2 Flare	1/2 Flare	1/2 Flare	1/2 Flare	1/2 Flare
Condensate Line (in., I.D.)	1	1	1	1	1

EEV: Electronic Expansion Valve

Power wiring is field supplied and must comply with the applicable local and national codes.

This unit comes with a dry nitrogen charge.

All capacities are net with a combination ratio between 95-105%.

Rated capacity is certified under AHRI Standard 1230. Ratings are subject to change without notice. Current certified ratings are available at [www.ahridirectory.org](http://www.ahridirectory.org).

<sup>1</sup>Max. power input is rated at maximum setting value.

<sup>2</sup>Low ambient performance with LGRED® heat technology is included in Multi V 5 Air



Due to our policy of continuous product innovation, some specifications may change without notification.  
©LG Electronics U.S.A., Inc., Englewood Cliffs, NJ. All rights reserved. "LG" is a registered trademark of LG Corp.

Source Units produced after February 2019.

<sup>3</sup>Take appropriate actions at the end of HVAC equipment life to recover, recycle, reclaim or destroy R410A refrigerant according to applicable regulations (40 CFR Part 82, Subpart F) under section 608 of CAA.

<sup>4</sup>Sound Power level is measured using rated conditions, and tested in a reverberation room per ISO Standard 3741.

<sup>5</sup>All communication cable to be minimum 18 AWG, 2-conductor, twisted, stranded, shielded and must comply with applicable local and national codes. Ensure the communication cable is properly grounded at the main outdoor unit only. Ⓞ Do not ground the ODU-IDU communication cable at any other point.

# GENERAL DATA



## Specifications – High-Static M2 and M3 Chassis

Table 3: Ducted High Static M2 and M3 Indoor Unit General Data.

Model No.	ARNU243M2A4	ARNU283M3A4
<b>Cooling Mode Performance</b>		
Capacity (Btu/h)	24,200	28,000
Max Power Input <sup>1</sup> (W)	430	650
L/M/H Power Input at Factory Default (W)	34 / 43 / 67	60 / 83 / 109
<b>Heating Mode Performance</b>		
Capacity (Btu/h)	27,300	31,500
Max Power Input <sup>1</sup> (W)	450	650
L/M/H Power Input at Factory Default (W)	34 / 43 / 67	60 / 83 / 109
<b>Entering Mixed Air</b>		
Cooling Max. (°F WB)	76	76
Heating Min. (°F DB) <sup>2</sup>	59	59
<b>Unit Data</b>		
Refrigerant Type <sup>3</sup>	R410A	R410A
Refrigerant Control	EEV	EEV
Sound Power <sup>4</sup> dB(A) (H/M/L, @0.24" ESP)	54 / 53 / 53	64 / 62 / 61
Net Unit Weight (lbs.)	82.9	96.1
Shipping Weight (lbs.)	95.5	110.0
Communication Cable <sup>5</sup> (No. x AWG)	2 x 18	2 x 18
<b>Fan</b>		
Type	Sirocco	Sirocco
Motor	1	1
Housing	2	2
Motor/Drive	Brushless Digitally Controlled / Direct	
Airflow Rate H/M/L (CFM) Standard Mode	640 / 520 / 435	1,235 / 1,060 / 915
Airflow Rate H/M/L (CFM) High Mode (Factory Set)	673 / 512 / 425	1,250 / 1,017 / 837
External Static Pressure (in. wg) Standard Mode	0.20	0.19
External Static Pressure (in. wg) High Mode (Factory Set)	0.24	0.23
<b>Piping</b>		
Liquid Line (in., O.D.)	3/8 Flare	3/8 Flare
Vapor Line (in., O.D.)	5/8 Flare	5/8 Flare
Condensate Line (in., I.D.)	1	1

EEV: Electronic Expansion Valve

Power wiring is field supplied and must comply with the applicable local and national codes.

This unit comes with a dry nitrogen charge.

All capacities are net with a combination ratio between 95-105%.

Rated capacity is certified under AHRI Standard 1230. Ratings are subject to change without notice. Current certified ratings are available at [www.ahridirectory.org](http://www.ahridirectory.org).

<sup>1</sup>Max. power input is rated at maximum setting value.

<sup>2</sup>Low ambient performance with LGRED<sup>®</sup> heat technology is included in Multi V 5 Air

Source Units produced after February 2019.

<sup>3</sup>Take appropriate actions at the end of HVAC equipment life to recover, recycle, reclaim or destroy R410A refrigerant according to applicable regulations (40 CFR Part 82, Subpart F) under section 608 of CAA.

<sup>4</sup>Sound Power level is measured using rated conditions, and tested in a reverberation room per ISO Standard 3741.

<sup>5</sup>All communication cable to be minimum 18 AWG, 2-conductor, twisted, stranded, shielded and must comply with applicable local and national codes. Ensure the communication cable is properly grounded at the main outdoor unit only. Ⓞ Do not ground the ODU-IDU communication cable at any other point.

Table 4: Ducted High Static B8 Indoor Unit General Data.

Model No.	ARNU363B8A4	ARNU423B8A4	ARNU483B8A4	ARNU763B8A4	ARNU963B8A4
<b>Cooling Mode Performance</b>					
Capacity (Btu/h)	36,200	42,000	48,100	76,400	95,900
Max. Power Input <sup>1</sup> (W)	800	800	800	800	800
L/M/H Power Input at Factory Default (W)	403 / 420 / 478	465 / 497 / 528	482 / 500 / 538	505 / 505 / 765	750 / 750 / 800
<b>Heating Mode Performance</b>					
Capacity (Btu/h)	40,600	43,800	51,200	86,000	107,500
Max. Power Input <sup>1</sup> (W)	800	800	800	800	800
L/M/H Power Input at Factory Default (W)	403 / 420 / 478	465 / 497 / 528	482 / 500 / 538	505 / 505 / 765	750 / 750 / 800
<b>Entering Mixed Air</b>					
Cooling Max. (°F WB)	76	76	76	76	76
Heating Min. (°F DB) <sup>2</sup>	59	59	59	59	59
<b>Unit Data</b>					
Refrigerant Type <sup>3</sup>	R410A	R410A	R410A	R410A	R410A
Refrigerant Control	EEV	EEV	EEV	EEV	EEV
Sound Pressure <sup>4</sup> dB(A) (H/M/L)	46 / 45 / 42	47 / 46 / 43	47 / 46 / 44	50 / 48 / 48	52 / 50 / 50
Net Unit Weight (lbs.)	192	192	192	192	192
Shipping Weight (lbs.)	222	222	222	222	222
Communication Cable <sup>5</sup> (No. x AWG)	2 x 18	2 x 18	2 x 18	2 x 18	2 x 18
<b>Fan</b>					
Type	Sirocco	Sirocco	Sirocco	Sirocco	Sirocco
Motor	2	2	2	2	2
Housing	2	2	2	2	2
Motor/Drive	Brushless Digitally Controlled / Direct				
Airflow Rate H/M/L (CFM) High Mode (Factory Set)	1,730 / 1,317 / 1,066	1,914 / 1,458 / 1,123	2,019 / 1,518 / 1,200	2,260 / 1,766 / 1,766	2,542 / 2,260 / 2,260
External Static Pressure (in. wg) High Mode (Factory Set)	0.70	0.70	0.70	0.87	0.87
<b>Piping</b>					
Liquid Line (in., O.D.)	3/8 Brazed	3/8 Brazed	3/8 Brazed	3/8 Brazed	3/8 Brazed
Vapor Line (in., O.D.)	3/4 Brazed	3/4 Brazed	3/4 Brazed	3/4 Brazed	7/8 Brazed
Condensate Line (in., I.D.)	1	1	1	1	1

EEV: Electronic Expansion Valve

Power wiring is field supplied and must comply with the applicable local and national codes.

This unit comes with a dry nitrogen charge.

All capacities are net with a combination ratio between 95-105%.

Rated capacity is certified under AHRI Standard 1230. Ratings are subject to change without notice. Current certified ratings are available at [www.ahridirectory.org](http://www.ahridirectory.org).

<sup>1</sup>Max. power input is rated at maximum setting value.

<sup>2</sup>Low ambient performance with LGRED<sup>®</sup> heat technology is included in Multi V 5 Air

Source Units produced after February 2019.

<sup>3</sup>Take appropriate actions at the end of HVAC equipment life to recover, recycle, reclaim or destroy R410A refrigerant according to applicable regulations (40 CFR Part 82, Subpart F) under section 608 of CAA.

<sup>4</sup>Sound Pressure levels are tested in an anechoic chamber under ISO Standard 3745.

<sup>5</sup>All communication cable to be minimum 18 AWG, 2-conductor, twisted, stranded, shielded and must comply with applicable local and national codes. Ensure the communication cable is properly grounded at the main outdoor unit only. ⚠ Do not ground the ODU-IDU communication cable at any other point.

# GENERAL DATA



## Specifications – Mid-Static M1 Chassis

Table 5: Ducted Mid-Static M1 Indoor Unit General Data.

Model No.	ARNU073M1A4	ARNU093M1A4	ARNU123M1A4	ARNU153M1A4	ARNU183M1A4	ARNU243M1A4
<b>Cooling Mode Performance</b>						
Capacity (Btu/h)	7,500	9,600	12,300	15,400	19,100	24,200
Max. Power Input <sup>1</sup> (W)	190	190	190	190	190	190
L/M/H Power Input at Factory Default (W)	25 / 30 / 39	26 / 32 / 40	31 / 38 / 46	46 / 53 / 67	55 / 63 / 85	58 / 74 / 91
<b>Heating Mode Performance</b>						
Capacity (Btu/h)	8,500	10,900	13,600	17,100	21,500	27,300
Max. Power Input <sup>1</sup> (W)	190	190	190	190	190	190
L/M/H Power Input at Factory Default (W)	25 / 30 / 39	26 / 32 / 40	31 / 38 / 46	46 / 53 / 67	55 / 63 / 85	58 / 74 / 91
<b>Entering Mixed Air</b>						
Cooling Max. (°F WB)	76	76	76	76	76	76
Heating Min. (°F DB) <sup>2</sup>	59	59	59	59	59	59
<b>Unit Data</b>						
Refrigerant Type <sup>3</sup>	R410A	R410A	R410A	R410A	R410A	R410A
Refrigerant Control	EEV	EEV	EEV	EEV	EEV	EEV
Sound Power <sup>4</sup> dB(A) (H/M/L, @0.24" ESP)	44 / 41 / 39	44 / 42 / 39	44 / 43 / 40	47 / 43 / 43	49 / 47 / 43	51 / 49 / 47
Net Unit Weight (lbs.)	56.0	56.0	56.0	56.0	56.0	59.0
Shipping Weight (lbs.)	67.0	67.0	67.0	67.0	67.0	70.0
Communication Cable <sup>5</sup> (No. x AWG)	2 x 18	2 x 18	2 x 18	2 x 18	2 x 18	2 x 18
<b>Fan</b>						
Type	Sirocco	Sirocco	Sirocco	Sirocco	Sirocco	Sirocco
Motor	1	1	1	1	1	1
Housing	1	1	1	1	1	1
Motor/Drive	Brushless Digitally Controlled / Direct					
Airflow Rate H/M/L (CFM) Standard Mode	372 / 315 / 257	385 / 329 / 272	399 / 344 / 286	593 / 413 / 344	606 / 493 / 413	641 / 592 / 493
Airflow Rate H/M/L (CFM) High Mode (Factory Set)	361 / 279 / 211	376 / 296 / 229	392 / 328 / 262	570 / 392 / 328	638 / 556 / 392	703 / 638 / 556
External Static Pressure (in. wg) Standard Mode	0.10	0.10	0.10	0.10	0.10	0.10
External Static Pressure (in. wg) High Mode (Factory Set)	0.24	0.24	0.24	0.24	0.24	0.24
<b>Piping</b>						
Liquid Line (in., O.D.)	1/4 Flare	1/4 Flare	1/4 Flare	1/4 Flare	1/4 Flare	3/8 Flare
Vapor Line (in., O.D.)	1/2 Flare	1/2 Flare	1/2 Flare	1/2 Flare	1/2 Flare	5/8 Flare
Condensate Line (in., I.D.)	1	1	1	1	1	1

EEV: Electronic Expansion Valve

Power wiring is field supplied and must comply with the applicable local and national codes.

This unit comes with a dry nitrogen charge.

All capacities are net with a combination ratio between 95-105%.

Rated capacity is certified under AHRI Standard 1230. Ratings are subject to change without notice. Current certified ratings are available at [www.ahridirectory.org](http://www.ahridirectory.org).

<sup>1</sup>Max. power input is rated at maximum setting value.

<sup>2</sup>Low ambient performance with LGRED<sup>®</sup> heat technology is included in Multi V 5 Air

Source Units produced after February 2019.

<sup>3</sup>Take appropriate actions at the end of HVAC equipment life to recover, recycle, reclaim or destroy R410A refrigerant according to applicable regulations (40 CFR Part 82, Subpart F) under section 608 of CAA.

<sup>4</sup>Sound Power level is measured using rated conditions, and tested in a reverberation room per ISO Standard 3741.

<sup>5</sup>All communication cable to be minimum 18 AWG, 2-conductor, twisted, stranded, shielded and must comply with applicable local and national codes. Ensure the communication cable is properly grounded at the main outdoor unit only. Ⓞ Do not ground the ODU-IDU communication cable at any other point.





Table 6: Ducted Mid Static M2 Indoor Unit General Data.

Model No.	ARNU283M2A4	ARNU363M2A4	ARNU423M2A4
<b>Cooling Mode Performance</b>			
Capacity (Btu/h)	28,000	36,200	42,000
Max Power Input <sup>1</sup> (W)	430	430	430
L/M/H Power Input at Factory Default (W)	57 / 88 / 123	88 / 123 / 184	136 / 193 / 231
<b>Heating Mode Performance</b>			
Capacity (Btu/h)	31,500	40,600	47,000
Max Power Input <sup>1</sup> (W)	450	450	450
L/M/H Power Input at Factory Default (W)	57 / 88 / 123	88 / 123 / 184	136 / 193 / 231
<b>Entering Mixed Air</b>			
Cooling Max. (°F WB)	76	76	76
Heating Min. (°F DB) <sup>2</sup>	59	59	59
<b>Unit Data</b>			
Refrigerant Type <sup>3</sup>	R410A	R410A	R410A
Refrigerant Control	EEV	EEV	EEV
Sound Power <sup>4</sup> dB(A) (H/M/L, @0.24" ESP)	64 / 61 / 57	65 / 62 / 60	66 / 65 / 63
Net Unit Weight (lbs.)	86.2	86.2	86.2
Shipping Weight (lbs.)	99.2	99.2	99.2
Communication Cable <sup>5</sup> (No. x AWG)	2 x 18	2 x 18	2 x 18
<b>Fan</b>			
Type	Sirocco	Sirocco	Sirocco
Motor	1	1	1
Housing	2	2	2
<b>Motor/Drive</b>			
Airflow Rate H/M/L (CFM) Standard Mode	892 / 770 / 645	1,021 / 844 / 695	1,262 / 1,087 / 917
Airflow Rate H/M/L (CFM) High Mode (Factory Set)	845 / 676 / 528	1,031 / 845 / 676	1,260 / 1,076 / 888
External Static Pressure (in. wg) Standard Mode	0.20	0.20	0.20
External Static Pressure (in. wg) High Mode (Factory Set)	0.24	0.24	0.24
<b>Piping</b>			
Liquid Line (in., O.D.)	3/8 Flare	3/8 Flare	3/8 Flare
Vapor Line (in., O.D.)	5/8 Flare	5/8 Flare	5/8 Flare
Condensate Line (in., I.D.)	1	1	1

EEV: Electronic Expansion Valve

Power wiring is field supplied and must comply with the applicable local and national codes.

This unit comes with a dry nitrogen charge.

All capacities are net with a combination ratio between 95-105%.

Rated capacity is certified under AHRI Standard 1230. Ratings are subject to change without notice. Current certified ratings are available at [www.ahridirectory.org](http://www.ahridirectory.org).

<sup>1</sup>Max. power input is rated at maximum setting value.

<sup>2</sup>Low ambient performance with LGRED<sup>®</sup> heat technology is included in Multi V 5 Air



Source Units produced after February 2019.

<sup>3</sup>Take appropriate actions at the end of HVAC equipment life to recover, recycle, reclaim or destroy R410A refrigerant according to applicable regulations (40 CFR Part 82, Subpart F) under section 608 of CAA.

<sup>4</sup>Sound Power level is measured using rated conditions, and tested in a reverberation room per ISO Standard 3741.

<sup>5</sup>All communication cable to be minimum 18 AWG, 2-conductor, twisted, stranded, shielded and must comply with applicable local and national codes. Ensure the communication cable is properly grounded at the main outdoor unit only. Ⓞ Do not ground the ODU-IDU communication cable at any other point.

# GENERAL DATA



## Specifications – Mid-Static M3 Chassis

Table 7: Ducted Mid Static M3 Indoor Unit General Data.

Model No.	ARNU483M3A4	ARNU543M3A4
<b>Cooling Mode Performance</b>		
Capacity (Btu/h)	48,100	54,000
Max Power Input <sup>1</sup> (W)	650	650
L/M/H Power Input at Factory Default (W)	75 / 107 / 172	172 / 215 / 260
<b>Heating Mode Performance</b>		
Capacity (Btu/h)	54,200	61,400
Power Input <sup>1</sup> (W)	650	650
L/M/H Power Input at Factory Default (W)	75 / 107 / 172	172 / 215 / 260
<b>Entering Mixed Air</b>		
Cooling Max. (°F WB)	76	76
Heating Min. (°F DB) <sup>2</sup>	59	59
<b>Unit Data</b>		
Refrigerant Type <sup>3</sup>	R410A	R410A
Refrigerant Control	EEV	EEV
Sound Power <sup>4</sup> dB(A) (H/M/L, @0.24" ESP)	67 / 64 / 62	69 / 68 / 67
Net Unit Weight (lbs.)	96.1	96.1
Shipping Weight (lbs.)	110.0	110.0
Communication Cable <sup>5</sup> (No. x AWG)	2 x 18	2 x 18
<b>Fan</b>		
Type	Sirocco	Sirocco
Motor	1	1
Housing	2	2
Motor/Drive		
Airflow Rate H/M/L (CFM) Standard Mode	1,457 / 1,189 / 952	1,720 / 1,558 / 1,424
Airflow Rate H/M/L (CFM) High Mode (Factory Set)	1,482 / 1,191 / 918	1,744 / 1,614 / 1,482
External Static Pressure (in. wg) Standard Mode	0.19	0.19
External Static Pressure (in. wg) High Mode (Factory Set)	0.23	0.23
<b>Piping</b>		
Liquid Line (in., O.D.)	3/8 Flare	3/8 Flare
Vapor Line (in., O.D.)	5/8 Flare	5/8 Flare
Condensate Line (in., I.D.)	1	1

EEV: Electronic Expansion Valve

Power wiring is field supplied and must comply with the applicable local and national codes.

This unit comes with a dry nitrogen charge.

All capacities are net with a combination ratio between 95-105%.

Rated capacity is certified under AHRI Standard 1230. Ratings are subject to change without notice. Current certified ratings are available at [www.ahridirectory.org](http://www.ahridirectory.org).

<sup>1</sup>Max. power input is rated at maximum setting value.

<sup>2</sup>Low ambient performance with LGRED<sup>®</sup> heat technology is included in Multi V 5 Air

Due to our policy of continuous product innovation, some specifications may change without notification.  
©LG Electronics U.S.A., Inc., Englewood Cliffs, NJ. All rights reserved. "LG" is a registered trademark of LG Corp.

Source Units produced after February 2019.

<sup>3</sup>Take appropriate actions at the end of HVAC equipment life to recover, recycle, reclaim or destroy R410A refrigerant according to applicable regulations (40 CFR Part 82, Subpart F) under section 608 of CAA.

<sup>4</sup>Sound Power level is measured using rated conditions, and tested in a reverberation room per ISO Standard 3741.

<sup>5</sup>All communication cable to be minimum 18 AWG, 2-conductor, twisted, stranded, shielded and must comply with applicable local and national codes. Ensure the communication cable is properly grounded at the main outdoor unit only. Ⓞ Do not ground the ODU-IDU communication cable at any other point.



## Specifications – Low-Static Ducted L1/L2/L3 Chassis

Table 8: Ducted Low Static (L1, L2, L3 Frames) Indoor Unit General Data.

Model No.	ARNU073L1G4	ARNU093L1G4	ARNU123L2G4	ARNU153L2G4	ARNU183L2G4	ARNU243L3G4
<b>Cooling Mode Performance</b>						
Capacity (Btu/h)	7,500	9,600	12,300	15,400	19,100	24,000
Max Power Input <sup>1</sup> (W)	40	40	85	85	85	115
L/M/H Power Input at Factory Default (W)	24 / 28 / 31	24 / 29 / 39	29 / 34 / 41	34 / 41 / 56	41 / 56 / 71	48 / 63 / 103
<b>Heating Mode Performance</b>						
Capacity (Btu/h)	8,500	10,900	13,600	17,100	21,500	27,300
Max Power Input <sup>1</sup> (W)	40	40	85	85	85	115
L/M/H Power Input at Factory Default (W)	24 / 28 / 31	24 / 29 / 39	29 / 34 / 41	34 / 41 / 56	41 / 56 / 71	48 / 63 / 103
<b>Entering Mixed Air</b>						
Cooling Max. (°F WB) <sup>2</sup>	76	76	76	76	76	76
Heating Min. (°F DB) <sup>2</sup>	59	59	59	59	59	59
<b>Unit Data</b>						
Refrigerant Type <sup>3</sup>	R410A	R410A	R410A	R410A	R410A	R410A
Refrigerant Control	EEV	EEV	EEV	EEV	EEV	EEV
Sound Pressure <sup>4</sup> dB(A) (H/M/L)	27 / 26 / 23	30 / 26 / 23	31 / 29 / 26	34 / 31 / 29	36 / 34 / 31	39 / 35 / 32
Net Unit Weight (lbs.)	38.6	38.6	50.7	50.7	50.7	59.5
Shipping Weight (lbs.)	47.4	47.4	60.6	60.6	60.6	68.3
Communication Cable <sup>5</sup> (No. x AWG)	2 x 18	2 x 18	2 x 18	2 x 18	2 x 18	2 x 18
<b>Fan</b>						
Type	Sirocco	Sirocco	Sirocco	Sirocco	Sirocco	Sirocco
Motor	1	1	2	2	2	2
Housing	2	2	3	3	3	4
Motor/Drive	Brushless Digitally Controlled / Direct					
Airflow Rate H/M/L (CFM) Standard Mode	270 / 230 / 200	320 / 250 / 200	360 / 310 / 250	450 / 360 / 310	530 / 450 / 360	710 / 570 / 430
Airflow Rate H/M/L (CFM) High Mode (Factory Set)	270 / 230 / 200	320 / 250 / 200	360 / 310 / 250	450 / 360 / 310	530 / 450 / 360	710 / 570 / 430
External Static Pressure (in. wg) Standard Mode	0	0	0	0	0	0
External Static Pressure (in. wg) High Mode (Factory Set)	0.1	0.1	0.1	0.1	0.1	0.1
<b>Piping</b>						
Liquid Line (in., O.D.)	1/4 Flare	1/4 Flare	1/4 Flare	1/4 Flare	1/4 Flare	3/8 Flare
Vapor Line (in., O.D.)	1/2 Flare	1/2 Flare	1/2 Flare	1/2 Flare	1/2 Flare	5/8 Flare
Condensate Line (in., I.D.)	1	1	1	1	1	1

EEV: Electronic Expansion Valve

Power wiring is field supplied and must comply with the applicable local and national codes.

This unit comes with a dry nitrogen charge.

All capacities are net with a combination ratio between 95-105%.

Rated capacity is certified under AHRI Standard 1230. Ratings are subject to change without notice. Current certified ratings are available at [www.ahridirectory.org](http://www.ahridirectory.org).

<sup>1</sup>Max. power input is rated at maximum setting value.

<sup>2</sup>Low ambient performance with LGRED® heat technology is included in Multi V 5 Air



Due to our policy of continuous product innovation, some specifications may change without notification.  
©LG Electronics U.S.A., Inc., Englewood Cliffs, NJ. All rights reserved. "LG" is a registered trademark of LG Corp.

Source Units produced after February 2019.

<sup>3</sup>Take appropriate actions at the end of HVAC equipment life to recover, recycle, reclaim or destroy R410A refrigerant according to applicable regulations (40 CFR Part 82, Subpart F) under section 608 of CAA.

<sup>4</sup>Sound Pressure levels are tested in an anechoic chamber under ISO Standard 3745.

<sup>5</sup>All communication cable to be minimum 18 AWG, 2-conductor, twisted, stranded, shielded and must comply with applicable local and national codes. Shield must be joined and insulated throughout. Ensure the communication cable is properly grounded at the main outdoor unit only. ⚠ Do not ground the ODU-IDU communication cable at any other point.

# GENERAL DATA



## Specifications – Vertical Air Handler NJ Chassis

Table 9: Vertical / Horizontal NJ Chassis Air Handler Unit General Data.

Model No.	ARNU123NJA4	ARNU183NJA4	ARNU243NJA4	ARNU303NJA4	ARNU363NJA4
<b>Cooling Mode Performance</b>					
Capacity (Btu/h)	12,000	18,000	24,000	30,000	36,000
Max Power Input <sup>1</sup> (W)	228	228	228	228	228
L/M/H Power Input at Factory Default (W)	47 / 64 / 80	64 / 80 / 90	64 / 96 / 120	94 / 133 / 180	133 / 180 / 230
<b>Heating Mode Performance</b>					
Capacity (Btu/h)	13,500	20,000	27,000	34,000	40,000
Max Power Input <sup>1</sup> (W)	228	228	228	228	228
L/M/H Power Input at Factory Default (W)	47 / 64 / 80	64 / 80 / 90	64 / 96 / 120	94 / 133 / 180	133 / 180 / 230
<b>Entering Mixed Air</b>					
Cooling Max. (°F WB)	76	76	76	76	76
Heating Min. (°F DB) <sup>2</sup>	59	59	59	59	59
<b>Unit Data</b>					
Refrigerant Type <sup>3</sup>	R410A	R410A	R410A	R410A	R410A
Refrigerant Control	EEV	EEV	EEV	EEV	EEV
Sound Pressure <sup>4</sup> dB(A) (H/M/L)	42 / 41 / 39	42 / 42 / 41	43 / 42 / 41	44 / 43 / 42	45 / 44 / 43
Net Unit Weight (lbs.)	117	117	117	117	121
Shipping Weight (lbs.)	140	140	140	140	144
Communication Cable <sup>5</sup> (No. x AWG)	2 x 18	2 x 18	2 x 18	2 x 18	2 x 18
<b>Fan</b>					
Type	Sirocco	Sirocco	Sirocco	Sirocco	Sirocco
Motor	1	1	1	1	1
Housing	1	1	1	1	1
Motor/Drive	Brushless Digitally Controlled / Direct				
Airflow Rate H/M/L (CFM) Standard Mode	530 / 480 / 380	580 / 530 / 480	710 / 640 / 480	880 / 800 / 630	990 / 880 / 800
Airflow Rate H/M/L (CFM) High Mode (Factory Set)	530 / 480 / 380	580 / 530 / 480	710 / 640 / 480	880 / 800 / 630	990 / 880 / 800
External Static Pressure (in. wg) Standard Mode	0.3	0.3	0.3	0.3	0.3
External Static Pressure (in. wg) High Mode (Factory Set)	0.5	0.5	0.5	0.5	0.5
<b>Piping</b>					
Liquid Line (in., O.D.)	1/4 Flare	1/4 Flare	3/8 Flare	3/8 Flare	3/8 Flare
Vapor Line (in., O.D.)	1/2 Flare	1/2 Flare	5/8 Flare	5/8 Flare	5/8 Flare
Condensate Line (in., I.D.)	1 (3/4 FPT)	1 (3/4 FPT)	1 (3/4 FPT)	1 (3/4 FPT)	1 (3/4 FPT)

EEV: Electronic Expansion Valve

Power wiring is field supplied and must comply with the applicable local and national codes.

This unit comes with a dry nitrogen charge.

Rated capacity is certified under AHRI Standard 1230. Ratings are subject to change without notice. Current certified ratings are available at [www.ahridirectory.org](http://www.ahridirectory.org).

<sup>1</sup>Max power input is rated at maximum setting value.

<sup>2</sup>Low ambient performance with LGRED<sup>®</sup> heat technology is included in Multi V 5 Air

Source Units produced after February 2019.

<sup>3</sup>Take appropriate actions at the end of HVAC equipment life to recover, recycle, reclaim or destroy R410A refrigerant according to applicable regulations (40 CFR Part 82, Subpart F) under section 608 of CAA.

<sup>4</sup>Sound Pressure levels are tested in an anechoic chamber under ISO Standard 3745.

<sup>5</sup>All communication cable to be minimum 18 AWG, 2-conductor, twisted, stranded, shielded and must comply with applicable local and national codes. Shield must be joined and insulated throughout. Ensure the communication cable is properly grounded at the main outdoor unit only. Ⓝ Do not ground the ODU-IDU communication cable at any other point.

Multi V Ducted Indoor Units

## Specifications – Vertical Air Handler NK Chassis

Table 10: Vertical / Horizontal (NK Frame) Air Handler Unit General Data.

Model No.	ARNU423NKA4	ARNU483NKA4	ARNU543NKA4
<b>Cooling Mode Performance</b>			
Capacity (Btu/h)	42,000	48,000	54,000
Max Power Input <sup>1</sup> (W)	366	366	366
L/M/H Power Input at Factory Default (W)	186 / 215 / 260	186 / 264 / 330	264 / 312 / 370
<b>Heating Mode Performance</b>			
Capacity (Btu/h)	46,000	54,000	60,000
Max Power Input <sup>1</sup> (W)	366	366	366
L/M/H Power Input at Factory Default (W)	186 / 215 / 260	186 / 264 / 330	264 / 312 / 370
<b>Entering Mixed Air</b>			
Cooling Max. (°F WB)	76	76	76
Heating Min. (°F DB) <sup>2</sup>	59	59	59
<b>Unit Data</b>			
Refrigerant Type <sup>3</sup>	R410A	R410A	R410A
Refrigerant Control	EEV	EEV	EEV
Sound Pressure <sup>4</sup> dB(A) (H/M/L)	46 / 44 / 41	49 / 47 / 41	50 / 49 / 47
Net Unit Weight (lbs.)	165	165	165
Shipping Weight (lbs.)	181	181	181
Communication Cable <sup>5</sup> (No. x AWG)	2 x 18	2 x 18	2 x 18
<b>Fan</b>			
Type	Sirocco	Sirocco	Sirocco
Motor	1	1	1
Housing	1	1	1
Motor/Drive	Brushless Digitally Controlled / Direct		
Airflow Rate H/M/L (CFM) Standard Mode	1,250 / 1,100 / 1,000	1,400 / 1,260 / 1,000	1,475 / 1,400 / 1,260
Airflow Rate H/M/L (CFM) High Mode (Factory Set)	1,250 / 1,100 / 1,000	1,400 / 1,260 / 1,000	1,475 / 1,400 / 1,260
External Static Pressure (in. wg) Standard Mode	0.3	0.3	0.3
External Static Pressure (in. wg) High Mode (Factory Set)	0.5	0.5	0.5
<b>Piping</b>			
Liquid Line (in., O.D.)	3/8 Flare	3/8 Flare	3/8 Flare
Vapor Line (in., O.D.)	5/8 Flare	5/8 Flare	5/8 Flare
Condensate Line (in., I.D.)	1 (3/4 FPT)	1 (3/4 FPT)	1 (3/4 FPT)

EEV: Electronic Expansion Valve

Power wiring is field supplied and must comply with the applicable local and national codes.

This unit comes with a dry nitrogen charge.

Rated capacity is certified under AHRI Standard 1230. Ratings are subject to change without notice. Current certified ratings are available at [www.ahridirectory.org](http://www.ahridirectory.org).

<sup>1</sup>Max power input is rated at maximum setting value.

<sup>2</sup>Low ambient performance with LGRED<sup>®</sup> heat technology is included in Multi V 5 Air

Source Units produced after February 2019.

<sup>3</sup>Take appropriate actions at the end of HVAC equipment life to recover, recycle, reclaim or destroy R410A refrigerant according to applicable regulations (40 CFR Part 82, Subpart F) under section 608 of CAA.

<sup>4</sup>Sound Pressure levels are tested in an anechoic chamber under ISO Standard 3745.

<sup>5</sup>All communication cable to be minimum 18 AWG, 2-conductor, twisted, stranded, shielded and must comply with applicable local and national codes. Shield must be joined and insulated throughout. Ensure the communication cable is properly grounded at the main outdoor unit only. ⓧ Do not ground the ODU-IDU communication cable at any other point.

# GENERAL DATA



## Electrical - Mid and High-Static M1/M2/M3/B8 Chassis

Table 11: Ducted High Static Indoor Unit Electrical Data.

Model	Voltage Range	MCA	MOP	Rated Amps (A)	Power Supply			Power Input (W)		
					Hz	Volts	Phase	Max.Cooling	Max.Heating	L / M / H at Factory Default
<b>M1 Units - Mid Static</b>										
ARNU073M1A4	208-230	2.0	15	1.6	60	208-230	1	190	190	25 / 30 / 39
ARNU093M1A4		2.0		1.6				190	190	26 / 32 / 40
ARNU123M1A4		2.0		1.6				190	190	31 / 38 / 46
ARNU153M1A4		2.0		1.6				190	190	46 / 53 / 67
ARNU183M1A4		2.0		1.6				190	190	55 / 63 / 85
ARNU243M1A4		2.0		1.6				190	190	58 / 74 / 91
<b>M2 Units - Mid and High Static</b>										
ARNU073M2A4	208-230	2.9	15	2.3	60	208-230	1	430	430	21 / 29 / 38
ARNU093M2A4		2.9		2.3				430	430	21 / 29 / 38
ARNU123M2A4		2.9		2.3				430	430	25 / 34 / 43
ARNU153M2A4		2.9		2.3				430	430	25 / 34 / 43
ARNU183M2A4		2.9		2.3				430	430	34 / 43 / 67
ARNU243M2A4		2.9		2.3				430	430	34 / 43 / 67
ARNU283M2A4		2.9		2.3				430	430	57 / 88 / 123
ARNU363M2A4		2.9		2.3				430	430	88 / 123 / 184
ARNU423M2A4		2.9		2.3				430	430	136 / 193 / 231
<b>M3 Units - Mid and High Static</b>										
ARNU283M3A4	208-230	3.1	15	2.5	60	208-230	1	650	650	60 / 83 / 109
ARNU363M3A4		3.1		2.5				650	650	75 / 107 / 161
ARNU423M3A4		3.1		2.5				650	650	75 / 107 / 161
ARNU483M3A4		3.1		2.5				650	650	75 / 107 / 172
ARNU543M3A4		3.1		2.5				650	650	172 / 215 / 260
<b>B8 Units - High Static</b>										
ARNU363B8A4	208-230	6.5	15	5.2	60	208-230	1	800	800	403 / 420 / 478
ARNU423B8A4		6.5		5.2				800	800	465 / 497 / 528
ARNU483B8A4		6.5		5.2				800	800	482 / 500 / 538
ARNU763B8A4		6.5		5.2				800	800	505 / 505 / 765
ARNU963B8A4		6.5		5.2				800	800	750 / 750 / 800

MCA : Minimum Circuit Ampacity.

MOP : Maximum Overcurrent Protection.

Units are suitable for use on an electrical system where voltage supplied to unit terminals is within the listed range limits.

Select wire size based on the larger MCA value.

Instead of fuse, use the circuit breaker.

Max. power input is rated at maximum setting value.

Multi V Ducted Indoor Units

Table 12: Ducted Low Static L1, L2, L3 Chassis Indoor Unit Electrical Data.

Model	Voltage Range	MCA	MOP	Rated Amps (A)	Power Supply			Power Input <sup>1</sup> (W)		
					Hz	Volts	Phase	Max. Cooling	Max. Heating	L / M / H at Factory Default
<b>L1 Units</b>										
ARNU073L1G4	208-230	0.5	15	0.4	60	208-230	1	40	40	24 / 28 / 31
ARNU093L1G4		0.5		0.4				40	40	24 / 29 / 39
<b>L2 Units</b>										
ARNU123L2G4	208-230	1.0	15	0.76	60	208-230	1	85	85	29 / 34 / 41
ARNU153L2G4		1.0		0.76				85	85	34 / 41 / 56
ARNU183L2G4		1.0		0.76				85	85	41 / 56 / 71
<b>L3 Units</b>										
ARNU243L3G4	208-230	1.2	15	0.97	60	208-230	1	115	115	48 / 63 / 103

MCA : Minimum Circuit Ampacity.

MOP : Maximum Overcurrent Protection.

Units are suitable for use on an electrical system where voltage supplied to unit terminals is within the listed range limits.

Select wire size based on the larger MCA value.

Use a circuit breaker instead of fuses.

<sup>1</sup>Max. power input is rated at maximum setting value.

# GENERAL DATA



## Electrical – Vertical Air Handling Unit NJ/NK Chassis

Table 13: Vertical / Horizontal NJ, NK Chassis Air Handling Unit Electrical Data.

Model	Voltage Range	MCA	MOP	Rated Amps (A)	Power Supply			Power Input <sup>1</sup> (W)		
					Hz	Volts	Phase	Max. Cooling	Max. Heating	L / M / H at Factory Default
<b>NJ Frames</b>										
ARNU123NJA4	208-230	1.4	15	1.12	60	208-230	1	228	228	47 / 64 / 80
ARNU183NJA4		1.4		1.12				228	228	64 / 80 / 90
ARNU243NJA4		1.4		1.12				228	228	64 / 96 / 120
ARNU303NJA4		1.4		1.12				228	228	94 / 133 / 180
ARNU363NJA4		1.4		1.12				228	228	133 / 180 / 230
<b>NK Frames</b>										
ARNU423NKA4	208-230	2.25	15	1.8	60	208-230	1	366	366	186 / 215 / 260
ARNU483NKA4		2.25		1.8				366	366	186 / 264 / 330
ARNU543NKA4		2.25		1.8				366	366	264 / 312 / 370

MCA : Minimum Circuit Ampacity.

MOP : Maximum Overcurrent Protection.

Units are suitable for use on an electrical system where voltage supplied to unit terminals is within the listed range limits.

Select wire size based on the larger MCA value.

Instead of fuse, use the circuit breaker.

<sup>1</sup>Max. power input is rated at maximum setting value.



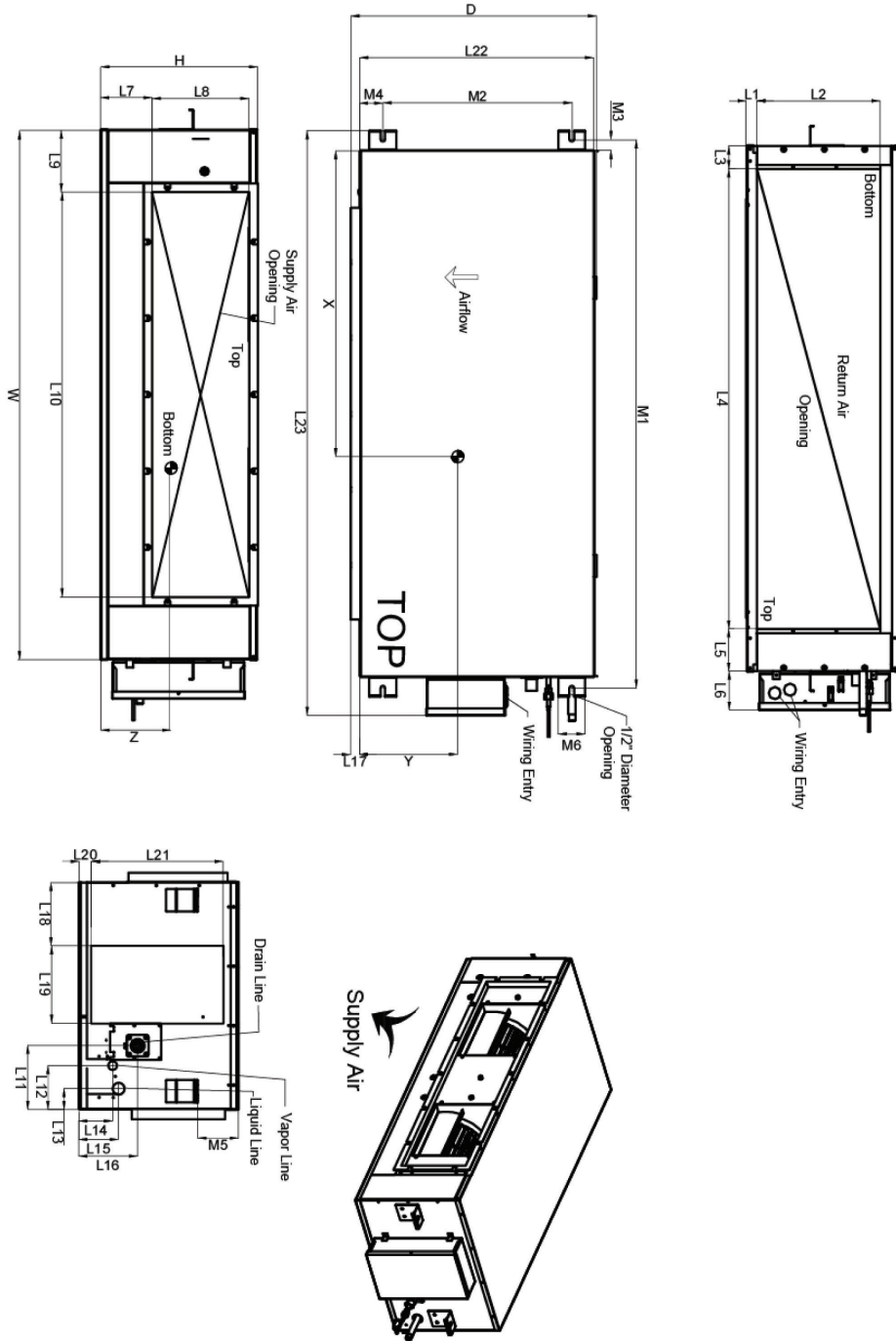

W	61 1/2"
D	28 5/8"
H	18 1/8"
L1	2 3/8"
L2	15 7/16"
L3	2"
L4	55"
L5	4 9/16"
L6	4 1/2"
L7	6"
L8	11 5/8"
L9	6 3/4"
L10	44 1/4"
L11	7 5/8"
L12	5 1/4"
L13	2 1/2"
L14	4 3/4"
L15	5 1/2"
L16	6 7/8"
L17	1 3/16"
L18	7 13/16"
L19	9 3/16"
L20	1 5/16"
L21	15 3/8"
L22	27 1/8"
L23	68 1/4"
M1	63 13/16"
M2	22"
M3	1 3/16"
M4	2 1/2"
M5	4 1/8"
M6	3 3/16"

**Center of Gravity**

X	31 1/16"
Y	18 1/8"
Z	8 3/4"

Note - All dimensions have a tolerance of ± 0.25 in.  
 = Center of Gravity

# GENERAL DATA



## Dimensions – Mid and High-Static Ducted M2 Chassis

[Unit: inch]

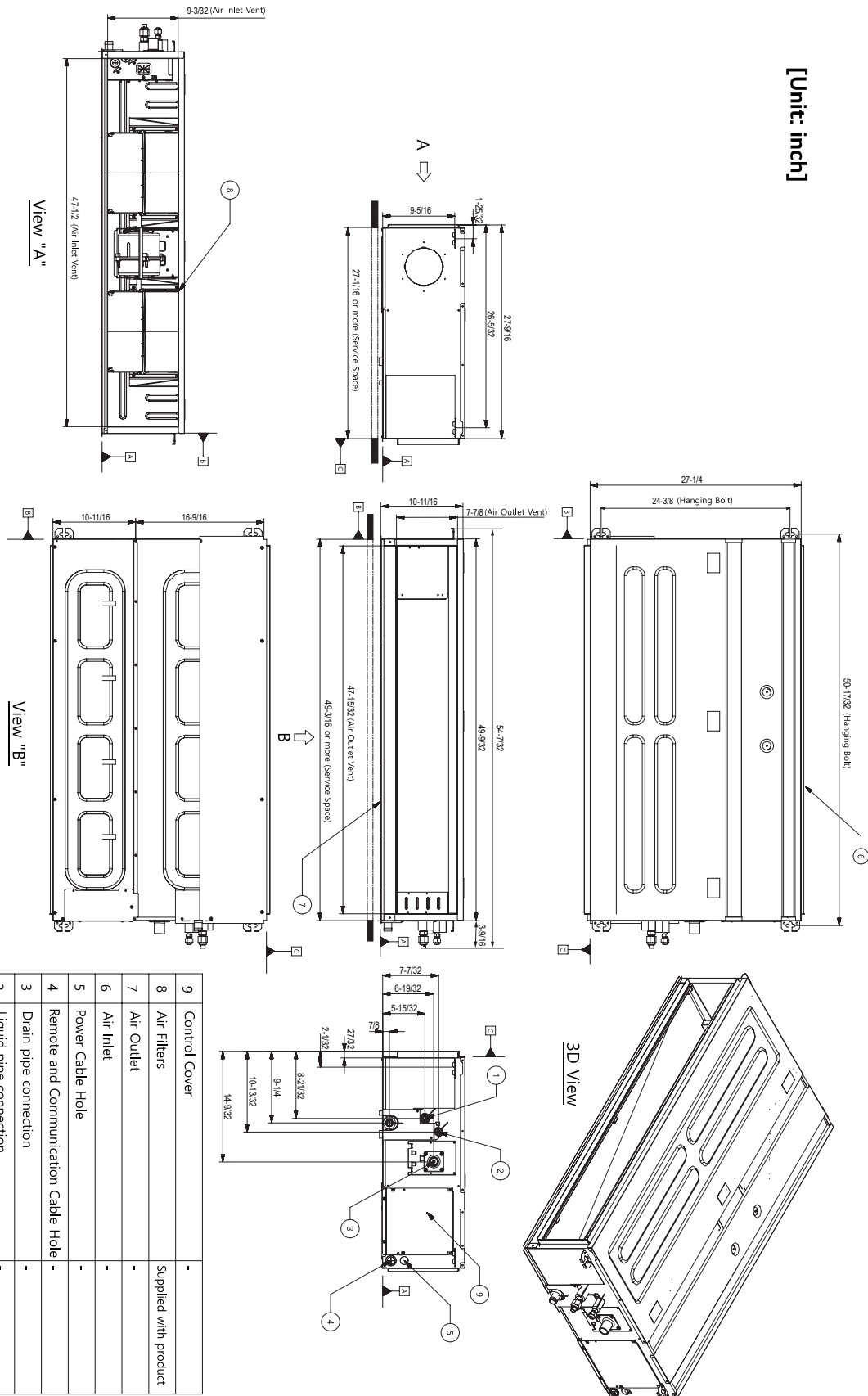

No.	Part Name	Description
9	Control Cover	-
8	Air Filters	Supplied with product
7	Air Outlet	-
6	Air Inlet	-
5	Power Cable Hole	-
4	Remote and Communication Cable Hole	-
3	Drain pipe connection	-
2	Liquid pipe connection	-
1	Gas pipe connection	-

Due to our policy of continuous product innovation, some specifications may change without notification.  
 ©LG Electronics U.S.A., Inc., Englewood Cliffs, NJ. All rights reserved. "LG" is a registered trademark of LG Corp.



[Unit: inch]

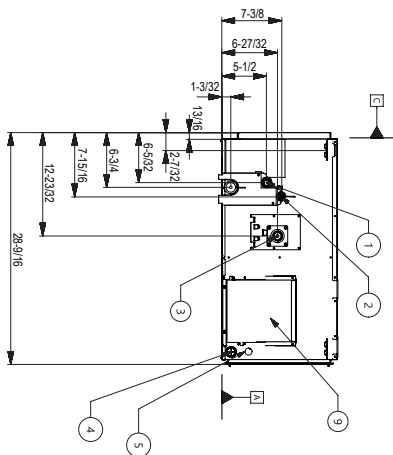
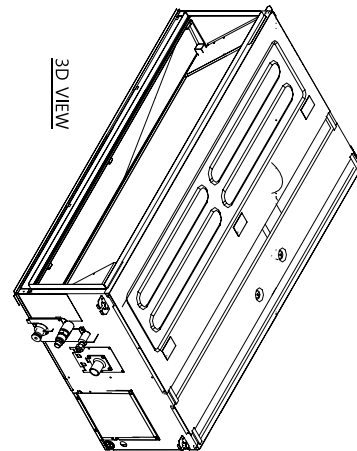
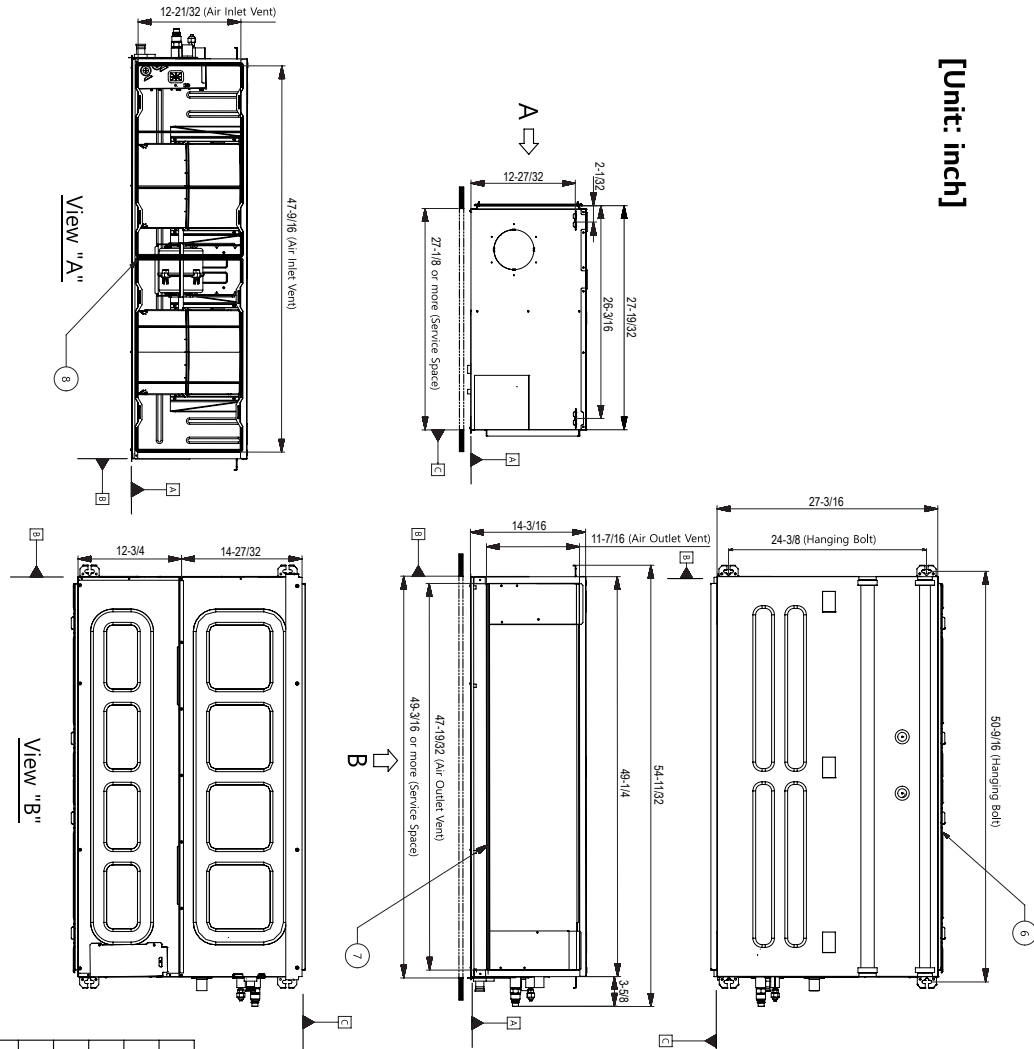

No.	Part Name	Description
1	Gas pipe connection	-
2	Liquid pipe connection	-
3	Drain pipe connection	-
4	Remote and Communication Cable Hole	-
5	Power Cable Hole	-
6	Air Inlet	-
7	Air Outlet	-
8	Air Filters	Supplied with product
9	Control Cover	-

# GENERAL DATA



## Dimensions – Mid-Static Ducted M1 Chassis

Multi V Ducted Indoor Units

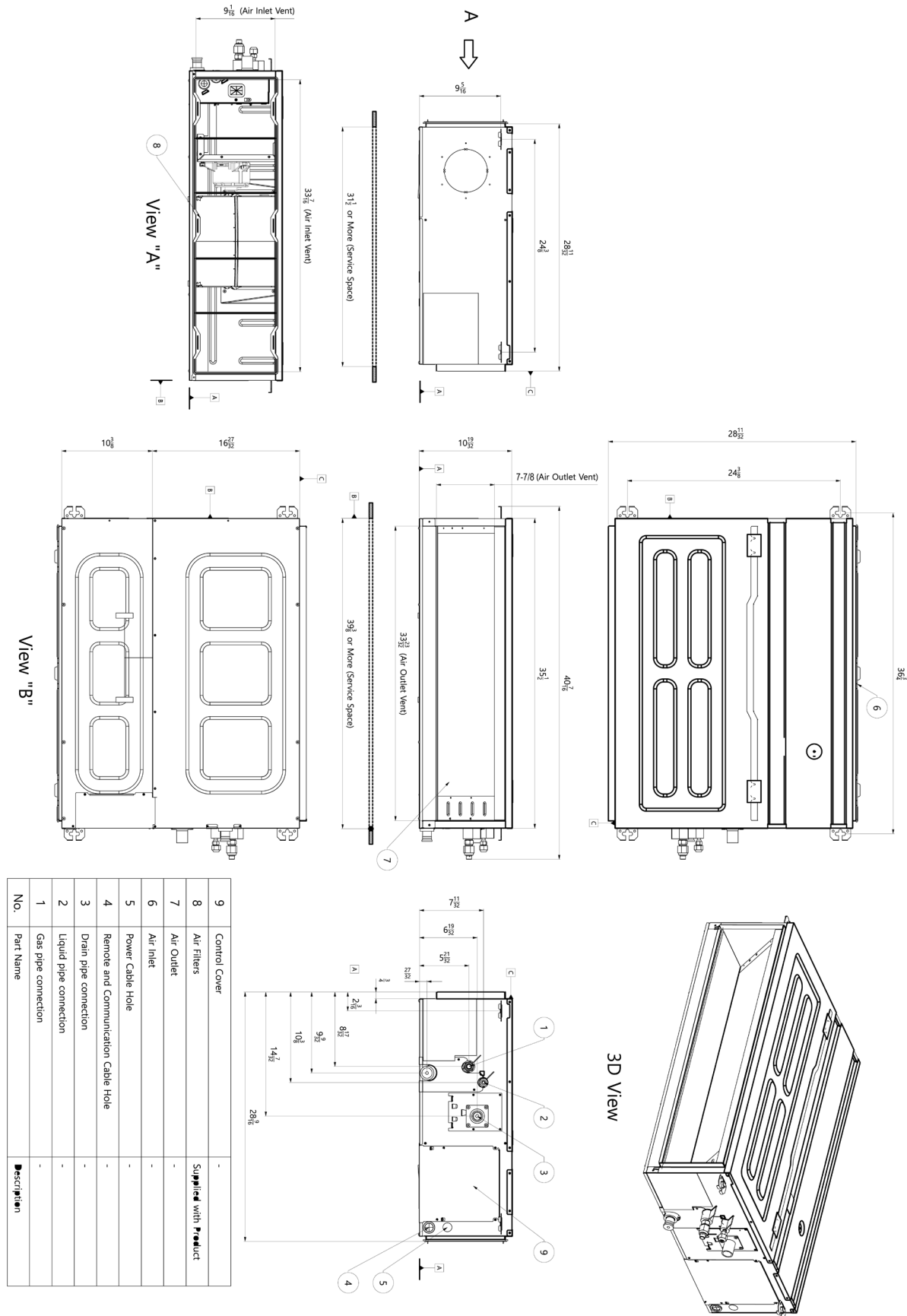

Dimensions – Low-Static Ducted L1/L2/L3 Chassis

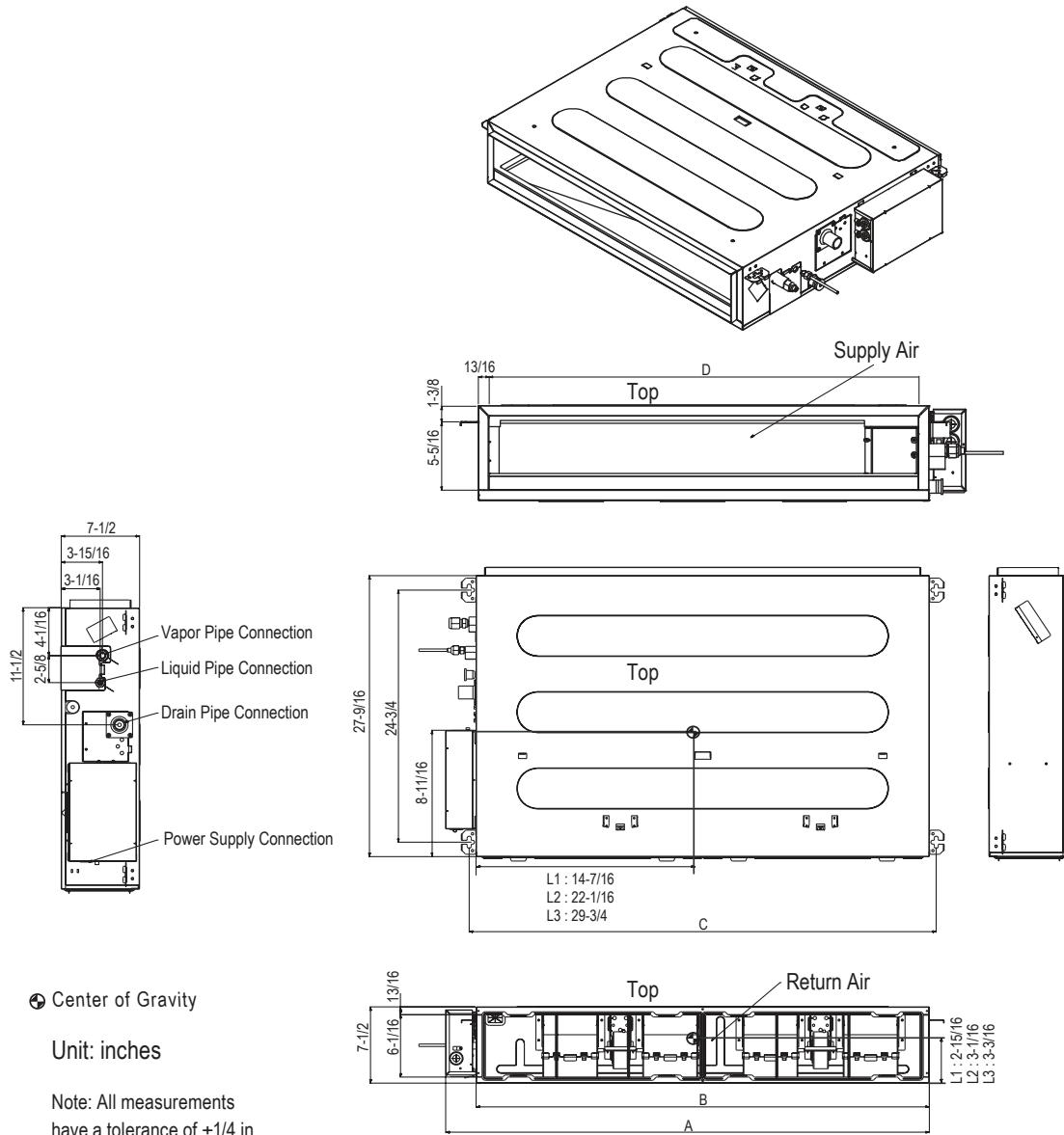

Installation Manual

	A	B	C	D	Supply Duct Connection					Return Duct Connection				
					Type	Height	Width	Flange Width	Flange Depth	Opening Location	Height	Width	Flange Width	Flange Depth
ARNU073L1G4 ARNU093L1G4	30-1/2	27-9/16	28-7/8	26	Flange	5-7/8	26	13/16	5/8	Rear	6-1/8	26	3/4	No Flange
										Bottom	6-1/16	26	3/4	No Flange
ARNU123L2G4 ARNU153L2G4 ARNU183L2G4	38-3/8	35-7/16	36-3/4	33-7/8	Flange	5-7/8	33-13/16	13/16	5/8	Rear	6-1/8	33-11/16	3/4	No Flange
										Bottom	6-1/16	33-11/16	3/4	No Flange
ARNU243L3G4	46-1/4	43-5/16	44-5/8	41-3/4	Flange	5-7/8	41-3/4	13/16	5/8	Rear	6-1/8	41-11/16	3/4	No Flange
										Bottom	6-1/16	41-11/16	3/4	No Flange

# GENERAL DATA



## Dimensions – Vertical Air Handler NJ Chassis

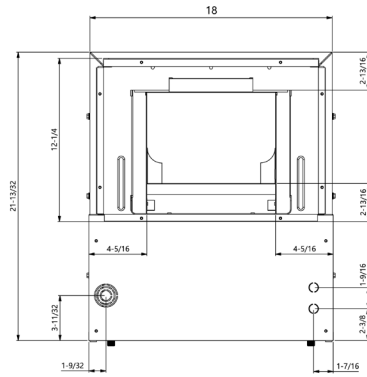

Top View

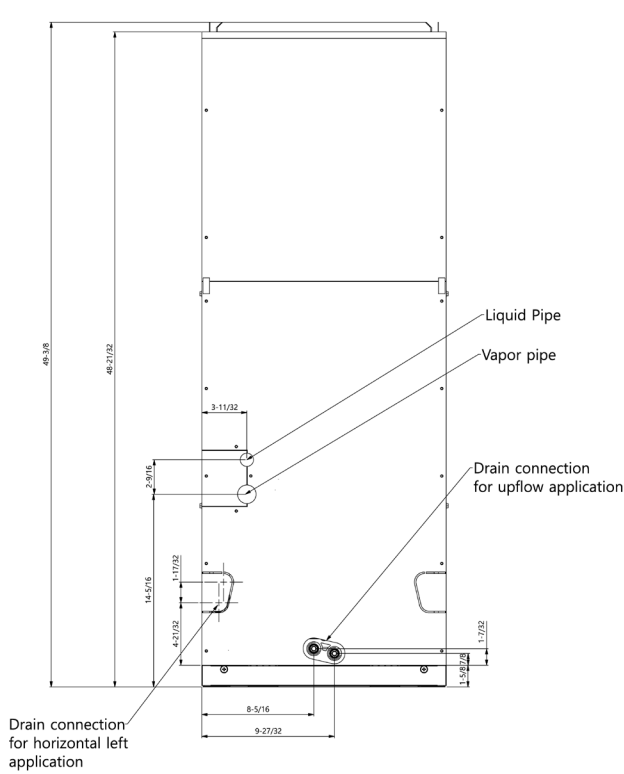

Front View

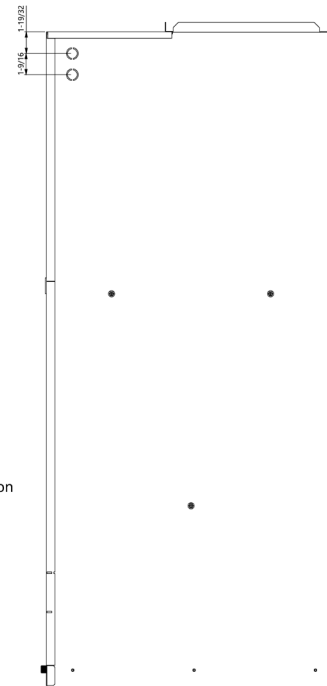

Side View

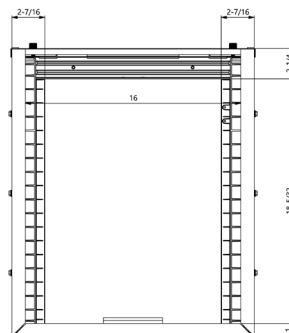

Bottom View

Multi V Ducted Indoor Units



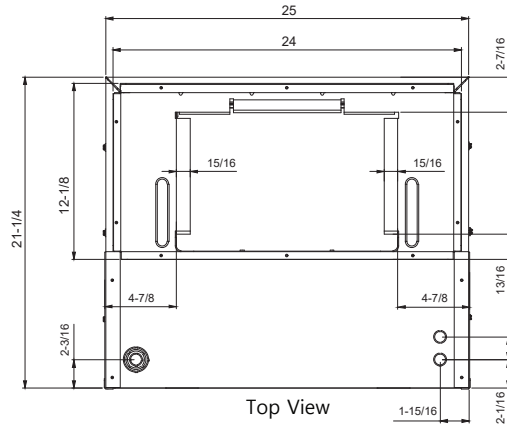

Top View

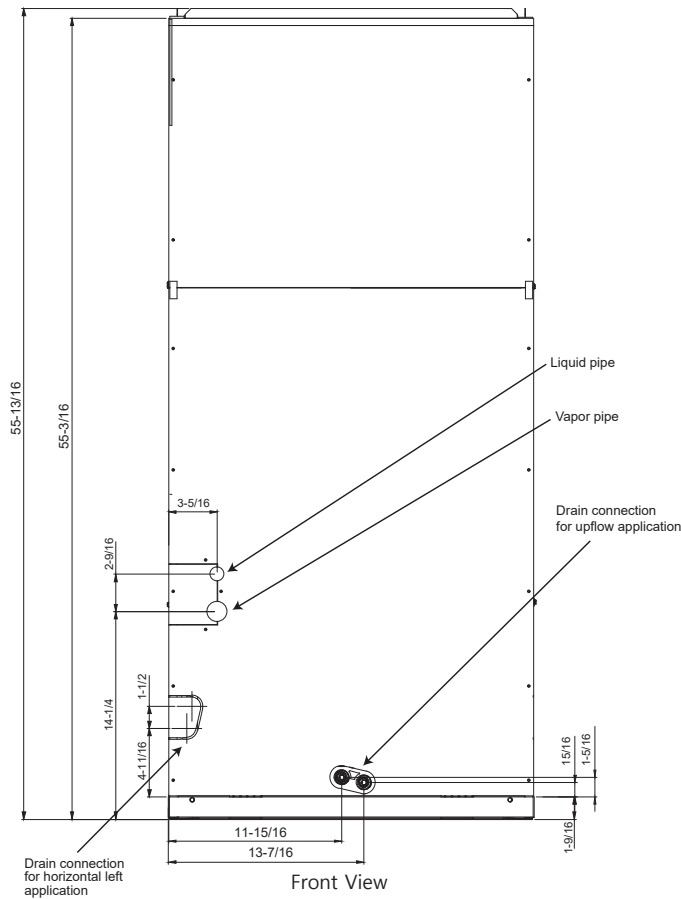

Front View

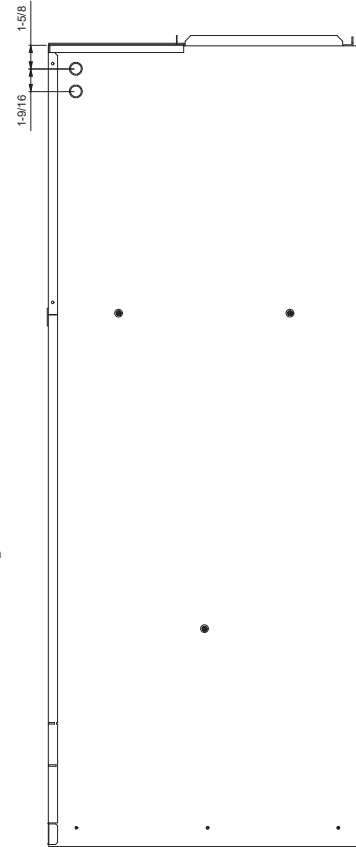

Side View

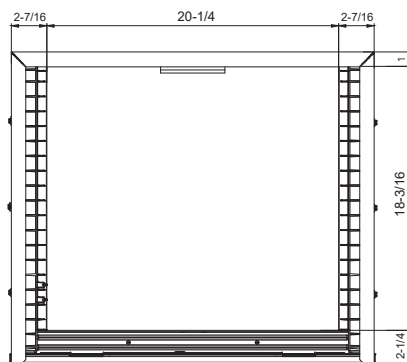

Bottom View

Unit: inch

# GENERAL DATA



## Refrigerant Piping Diagrams

Figure 6: Mid Static Ducted M1/M2/M3, High-Static Ducted M2/M3, Low-Static Ducted L1/L2L3/B3/B4, and Vertical Air Handler NJ/NK Refrigerant Piping Diagram

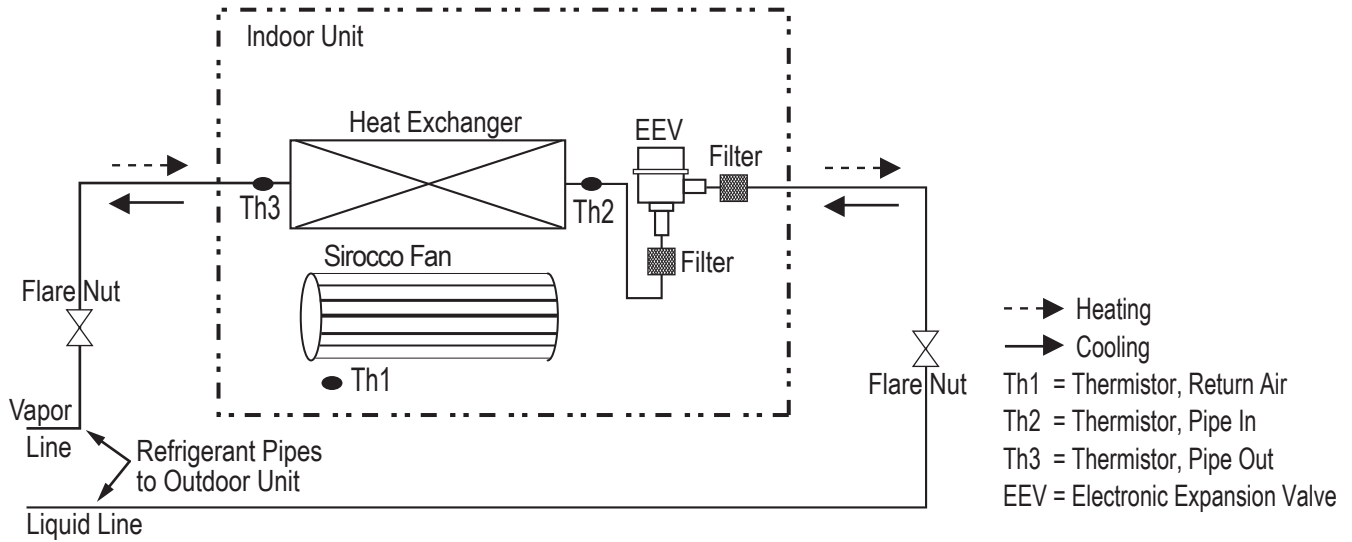
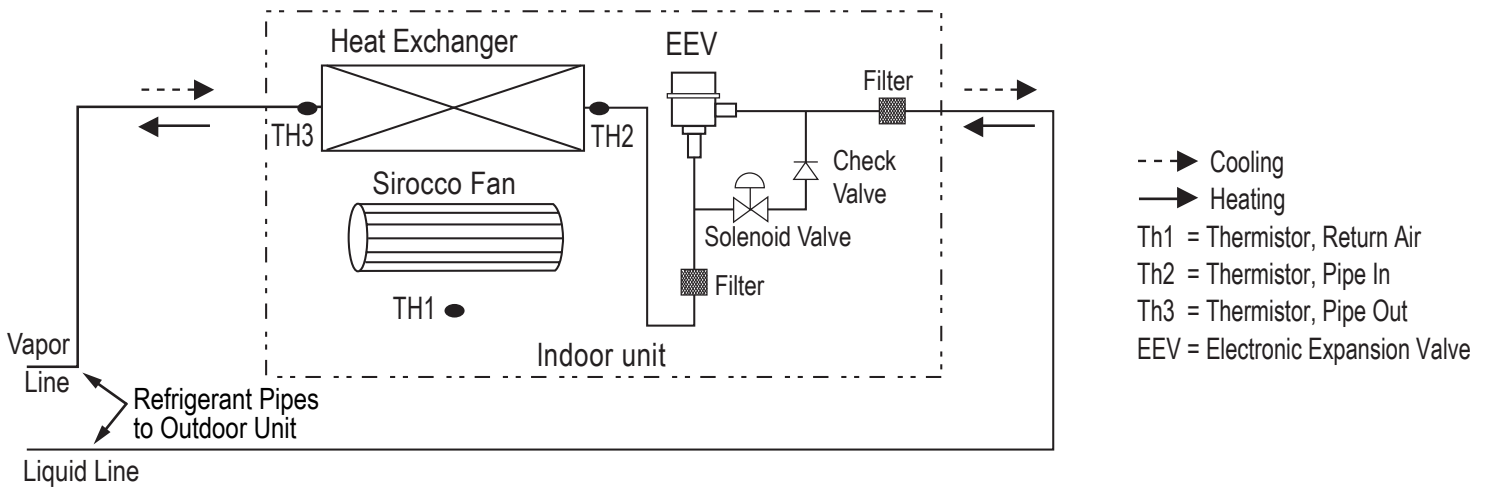

Figure 7: High-Static Ducted B8 Refrigerant Piping Diagram



Multi V Ducted Indoor Units



## Location Selection

### **⚠ DANGER**

To avoid the possibility of fire, do not install the unit in an area where combustible gas may generate, flow, stagnate, or leak. Failure to do so will cause serious bodily injury or death. Before beginning installation, read the safety summary at the beginning of this manual.

#### **Note:**

Select a location for installing the indoor unit (IDU) that meets the following conditions:

- Where there is enough structural strength to bear the weight of the unit.
- Operating sound from the unit will not disturb occupants.
- Include enough space for service access.
- Include space for drainage to ensure condensate flows properly out of the unit when it is in cooling mode.
- Use a level indicator to ensure the unit is installed on a level plane.

#### **Note:**

The unit may be damaged, may malfunction, and/or will not operate as designed if installed in any of these conditions:

- ⊘ Do not install the unit near a heat or steam source (Figure 8) , or where considerable amounts of oil, iron powder, or flour are used. These materials may generate condensate, cause a reduction in heat exchanger efficiency, or malfunction of the condensate drain. If this is a potential problem, install a ventilation fan large enough to vent out these materials
- ⊘ Do not install the unit where it will be subjected to direct thermal radiation from other heat sources.
- ⊘ Do not install the unit in an area where combustible gas may generate, flow, stagnate, or leak. There is the possibility of fire.
- ⊘ Do not install the unit in a location where acidic solution and spray (sulfur) are often used.
- ⊘ Do not use the unit in environments where oil, steam, sulfuric gas, or volatile organic compounds (VOC) are present.
- ⊘ Do not install additional ventilation products on the chassis of the unit.
- ⊘ Do not install the unit near high-frequency generator sources.

### Installing in an Area Exposed to Unconditioned Air

In some installation applications, areas (floors, walls) in some rooms may be exposed to unconditioned air. The room may be above or next to an unheated garage or storeroom. To counter this condition:

- Verify that carpet is or will be installed (carpet may increase the temperature by three (3) degrees).
- Install radiant heat or another type of heating system to the floor.
- Add insulation between the floor joists.

Figure 8: Installing Near a Heat or Steam Source

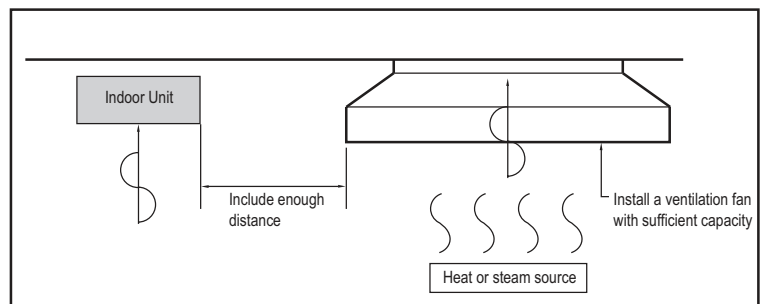

## Unpack and Inspect for Freight Damage

### **⚠ CAUTION**

Table 2 lists shipping and net weights. To help avoid personnel injury and unit damage, use at least two people when carrying a unit by hand.

#### **Note:**

⊘ Do not unpack the unit and remove protective materials until ready to install. Before opening the shipping container, check the container labeling to verify the unit received is the correct unit. Verify the unit capacity, type, and voltage. Refer to the Nomenclature chart on page 11. Before unpacking, carefully move packaged unit to a work area near installation location. After opening, if unit is damaged, repack unit as it was shipped. **RETAIN ALL PACKING MATERIALS.** In general, freight damage claims will be denied if the original packing materials are not retained for the claims adjustor to inspect. File a freight claim and order a replacement unit.

1. Place the box on a solid surface right side up.
2. Cut the white reinforced nylon straps, open the top of the box, and fold back all four flaps.

# INSTALLATION



## Install Ducted IDU Chassis

3. Remove the protective cardboard/Styrofoam® top sheet and place to the side.
4. The walls and top panels are not attached to the bottom of the box. Lift the carton by the flaps and remove the box walls and top.
5. Remove the moisture barrier plastic bonnet.
6. Check the unit nameplate data and model number. Verify the unit voltage, and capacities are correct before proceeding.
7. Locate and retain the piping/condensate accessory kit located in the bottom of the box under the refrigerant pipe stubs.
8. Using two people, carefully lift the unit and inspect for freight damage. ⚠ DO NOT lift by the refrigerant piping or drain pipe stub. Lift by the hangar brackets or chassis frame only. If damage is found, repack the unit as it was received in the original container.
9. If the unit is undamaged, remove and retain the installation manual. It is located under or on top of the unit.

### ⚠ WARNING

**Securely install threaded rod hangars (bolts) and hardware to prevent the chassis falling from its installation location.**

- There is risk of personnel injury from falling equipment.

**Installation work must be performed by trained personnel and in accordance with all local or other applicable codes.**

- There is risk of injury to personnel from incorrect installation.

#### Note:

- Ensure the unit is properly installed. Incorrectly installed units can malfunction resulting in degraded performance or an inoperative unit/system.
- Securely install threaded rod hangars (bolts) and hardware to prevent the chassis falling from its installation location. There is risk of equipment or property damage from falling equipment.
- Use a level indicator to ensure the chassis is installed on a level plane.

## Roughing In the Indoor Unit

1. Determine the installation location. Ensure the location has enough space to allow necessary duct connections and maintenance access.
2. Securely install the four field-provided threaded rod hangars to the overhead support locations.
3. Hang the chassis from the four field-supplied threaded rod hangars. Refer to the threaded rod hangar details in Figure 9.
4. Use a level to ensure the chassis is level and securely tighten the mounting nuts.
5. If local code requires an auxiliary drain pan under the unit, install a field-provided auxiliary drain pan.
6. Connect ductwork to the unit as necessary.

## Roughing-In Wall-Mounted Zone Controllers

#### Note:

- It may be necessary to use a handy box that is sized in metric units, depending on the controller model. Check with your LG representative to verify which size of handy box is needed for the zone controller in question.
- Use LG-supplied or field-supplied communications cable.
- Keep the communications cable away from high voltage wires and electromagnetic field (EMF) producing equipment.
- ⚠ Do not route power wiring and communications cables in the same conduit.
- Maintain the minimum distance required between the communications cable and power wiring. The minimum required space between the two is dependent on the voltage of the power wiring. Refer to the appropriate Multi V Outdoor Unit Engineering Manual for minimum distance specifications.

1. Proper indoor unit operation depends on the location of the room sensor. A good location will protect the zone controller from direct sunlight and external local sources of water vapor, and heated or cooled air. If no mounting height was specified by the building designer, place the handy box approximately fifty-five (55) inches above the finished floor.
2. Use field-provided or LG-provided cable to connect the zone controller. Pull communications cable between the zone controller handy box and the indoor unit.

Figure 9: Typical Threaded Rod Hanger and Attaching Hardware

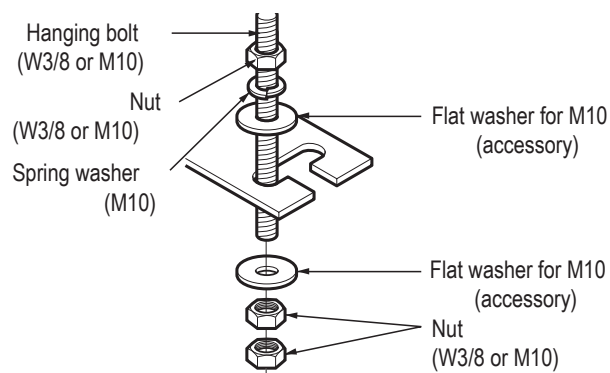

The following parts are field supplied:

- Hanging bolt - W-3/8" or 1/2"
- Nut - W-3/8" or M10
- Spring washer - M10

Included with the indoor unit:

- Flat washer - M10

3. Store a minimal amount of cable in the handy box. Any additional cable should be coiled and stored near the indoor unit control panel.
4. If using LG cable and additional cable is needed, order a thirty-three (33) foot LG Wired Remote Group Control Extension cable (Model No. PZCWRC1).
5. Coil any spare communications cable, tie-wrap it, and leave it next to the indoor unit location.
6. Zone controller rough-in is complete.

Figure 11: Low-Static Ducted Indoor Unit Dimensions.

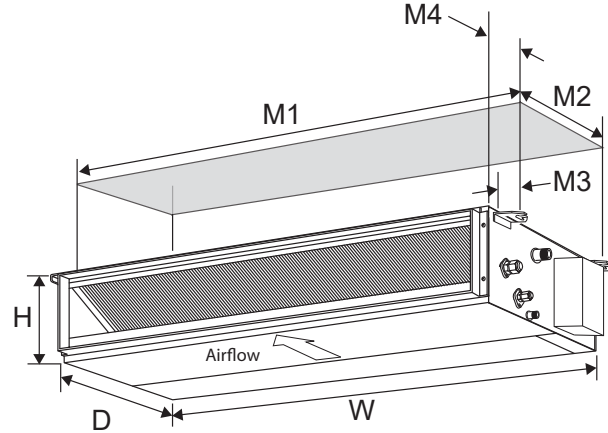

Figure 10: High-Static Ducted B8 Indoor Unit Dimensions.

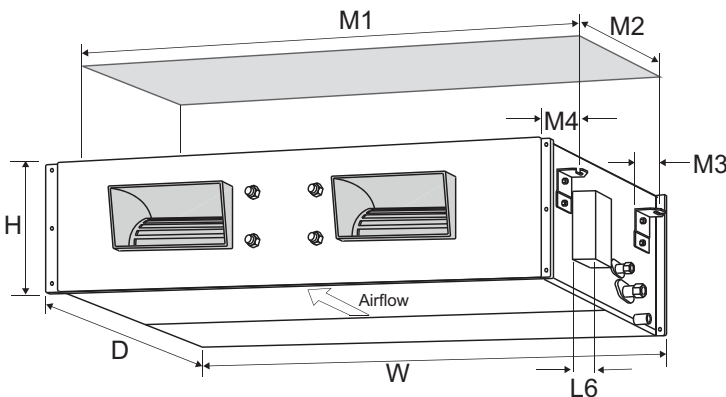

Figure 12: Mid-Static Ducted Indoor Unit M1/M2/M3 and High-Static Ducted Indoor Unit M2/M3 Dimensions.

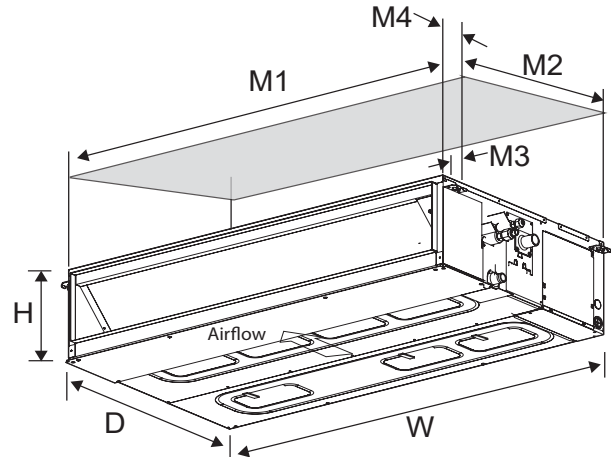

Table 14: Ducted Indoor Unit Dimensions and Weights.

Chassis Code	Weight (lbs.)	Major Dimensions (in.) <sup>1</sup>				Mounting Dimensions (in.)			
		W	D	H	L6	M1	M2	M3	M4
<b>Mid-Static and High-Static Ducted Indoor Units</b>									
M1	56	35-1/2	28-11/32	10-19/32	–	36-3/4	24-3/8	11/16	1-7/16
M2	86	54-7/32	27-1/4	10-11/16	–	50-17/32	24-3/8	11/16	1-7/16
M3	96	54-11/32	27-3/16	14-3/16	–	50-9/16	24-3/8	11/16	1-7/16
B8	192	61-5/8	27-1/8	18-1/8	4-11/16	63-7/8	22-7/8	1-3/16	1-3/16
<b>Low-Static Ducted Indoor Units</b>									
L1	39	30-1/2	27-9/16	7-1/2	3	28-7/8	24-3/4	5/8	1-3/8
L2	51	38-3/8	27-9/16	7-1/2	3	36-3/4	24-3/4	5/8	1-3/8
L3	60	46-1/4	27-9/16	7-1/2	3	44-5/8	24-3/4	5/8	1-3/8

<sup>1</sup>Case dimensions exclude insulation. Add approximately 1/8" for factory-applied external insulation for each side. High-Static models are insulated on all sides. Low-Static models are insulated on the bottom and end cold surfaces only between the fan discharge and midway to the rear of the unit.

# INSTALLATION



## Duct Connection Dimensions

Figure 13: High-Static Ducted (B8) Indoor Unit Duct Connection Dimensions.

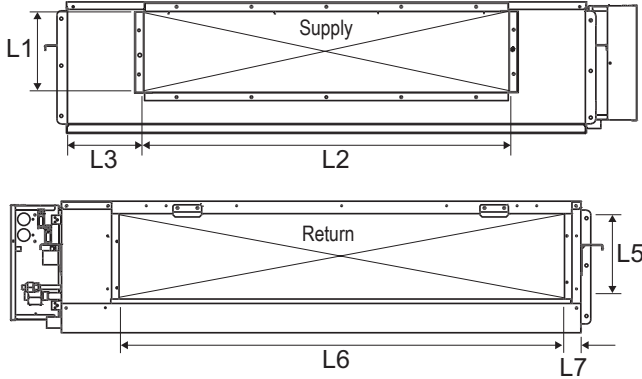

Figure 14: Low-Static Ducted (L1/L2/L3) Indoor Unit Duct Connection Dimensions.

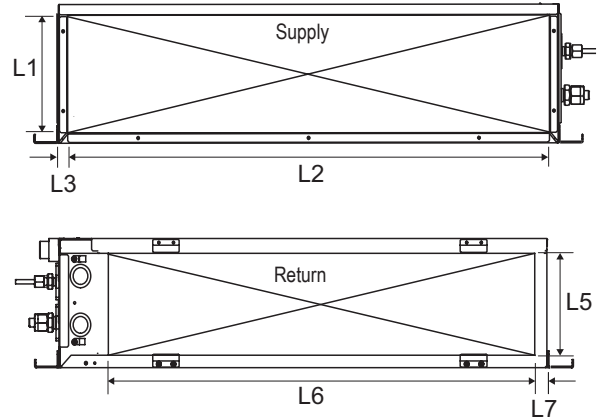

Figure 15: Mid-Static Ducted (M1/M2/M3) and High-Static Ducted (M2/M3) Indoor Unit Duct Connection Dimensions.

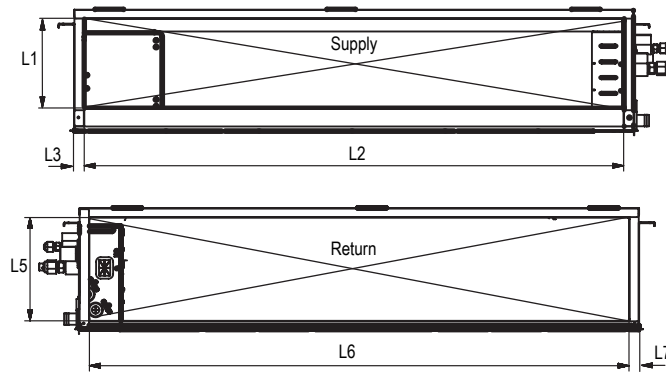

Table 15: Duct Connection Dimensions (in.).

Chassis Code	Supply Duct Connection					Return Duct Connection				
	Type	L1	L2	L3	Flange Depth	Opening Location	L5	L6	L7	Flange Depth
<b>Mid-Static and High-Static Ducted Indoor Units</b>										
M1	Flange	6-21/32	33-23/32	1-13/32	3/4	Rear	9-1/16	33-7/16	15/16	No Flange
M2	Flange	7-7/8	47-15/32	1-13/32	27/32	Rear	9-3/32	47-1/2	15/16	No Flange
M3	Flange	11-7/16	47-19/32	1-21/32	13/16	Rear	12-21/32	47-9/16	7/8	No Flange
B8	Flange	12-7/16	44-1/4	6-3/4	1	Rear	15-7/16	55	2	1-1/8
<b>Low-Static Ducted Indoor Units</b>										
L1	Flange	5-7/8	26	13/16	5/8	Rear	6-1/8	26	3/4	No Flange
						Bottom	6-1/16	26	3/4	No Flange
L2	Flange	5-7/8	33-13/16	13/16	5/8	Rear	6-1/8	33-11/16	3/4	No Flange
						Bottom	6-1/16	33-13/16	3/4	No Flange
L3	Flange	5-7/8	41-3/4	13/16	5/8	Rear	6-1/8	41-11/16	3/4	No Flange
						Bottom	6-1/16	41-11/16	3/4	No Flange

Multi V Ducted Indoor Units



Figure 16: High-Static Ducted (B8) Indoor Unit Maintenance Clearances.

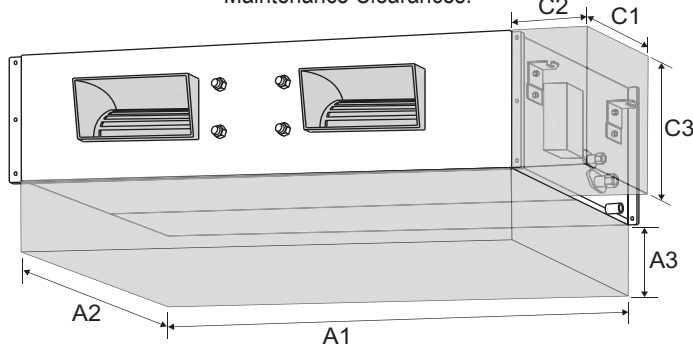

Figure 17: Low-Static Ducted (L1/L2/L3) Indoor Unit Maintenance Clearances.

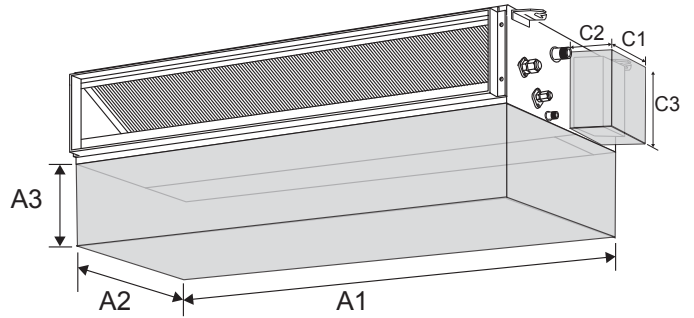

Figure 18: Mid-Static Ducted (M1/M2/M3) and High-Static Ducted (M2/M3) Indoor Unit Maintenance Clearances.

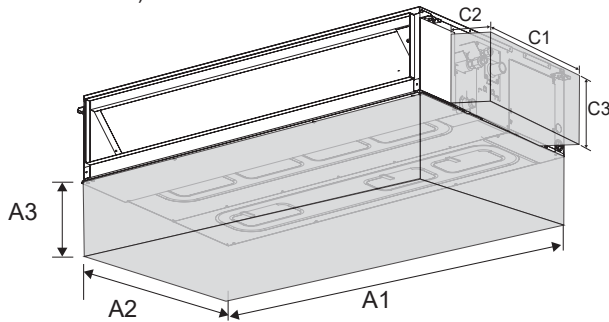

Figure 19: Mid-Static Ducted (M1/M2/M3) and High-Static Ducted (B8/M2/M3) Indoor Unit Maintenance Clearances.

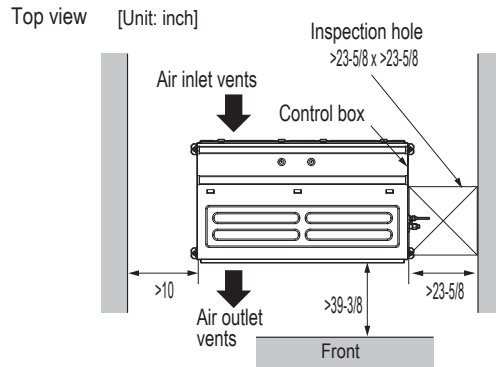

Table 16: Minimum Maintenance Clearances (in.).

Chassis Code	Control Panel Access				Major Maintenance Access			
	Location	C1	C2	C3	Location	A1	A2	A3*
<b>Mid-Static and High-Static Ducted Indoor Units</b>								
M1	Right End	8	8	10	Bottom	40	32	12
M2	Right End	8	8	10	Bottom	50	28	12
M3	Right End	8	8	12	Bottom	50	28	15
B8	Right End	12	14	18	Bottom	62	28	19
<b>Low-Static Ducted Indoor Units</b>								
L1	Right End	10	12	8	Bottom	30	25	8
L2	Right End	10	12	8	Bottom	38	25	8
L3	Right End	10	12	8	Bottom	46	25	8

\*Does not apply when the ceiling surface below can be removed.

# GENERAL INSTALLATION GUIDELINES



## General Mounting - Vertical / Horizontal Air Handler Units

Vertical / horizontal air handler units can be installed either in an upflow or a horizontal-left position.

### General Guidelines

- Support platforms must be sturdy enough to support the air handler unit plus any accessories including filter boxes. The size of the support must be bigger than the air handler unit; the unit itself must be placed at the center of the support.
- Vibration isolators (field-supplied) must be installed between the air handler unit and the support(s).
- Secure the plenum to support adapters and duct work.
- To prevent air leaks, seal all ducts following local codes.
- Follow all relevant building codes in installations in which an external condensate pan may be necessary. Supports for air handler units must be located in or above the external condensate pan.

### Specific Guidelines for Horizontal-Left Installation

- Units must not be installed where the access panels face up or down, nor where filter access is obstructed.
- If the air handler unit is suspended, use angled steel brackets with threaded rods as support.
- To ensure proper condensate drainage, the air handler unit must be installed so it is within 1/8" level of its length and width.

Multi V Ducted Indoor Units

Figure 20: Upflow Installation.

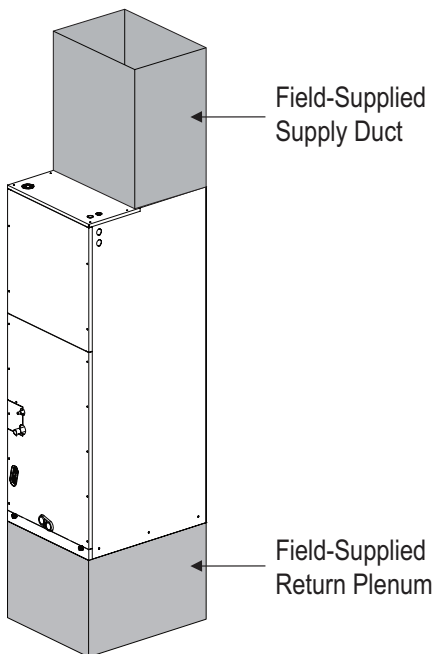

Figure 21: Horizontal-Left Installation.

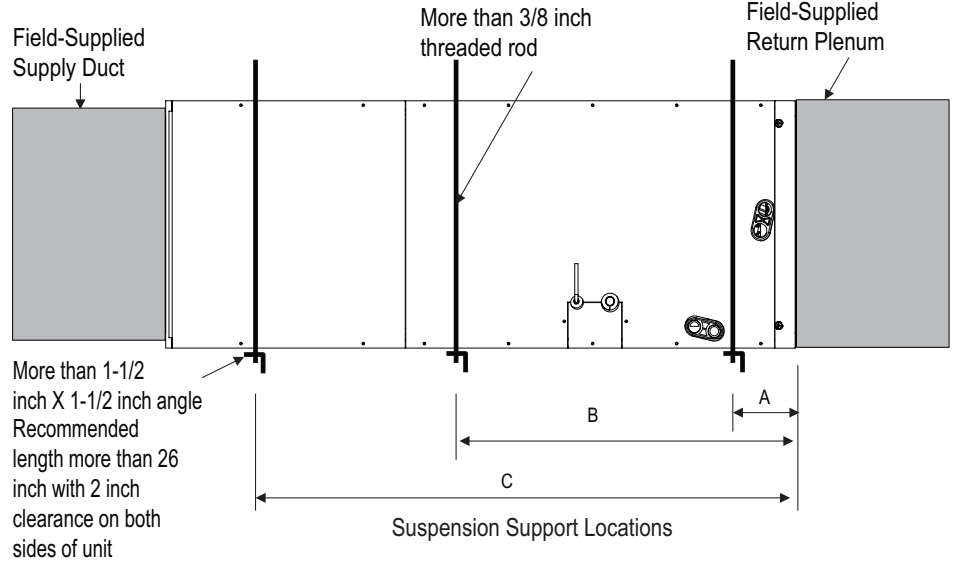

Table 17: Horizontal-Left Installation Dimensions.

Model No.	Capacity (Btu/h)	Dimensions (inches)		
		A	B	C
<b>NJ Frames</b>				
ARNU123NJA4	12,000	4	23	41-3/8
ARNU183NJA4	18,000			
ARNU243NJA4	24,000			
ARNU303NJA4	30,000			
ARNU363NJA4	36,000			
<b>NK Frames</b>				
ARNU423NKA4	42,000	4	29	48
ARNU483NKA4	48,000			
ARNU543NKA4	54,000			

### Duct Work For Vertical / Horizontal Air Handler Units

- Use at least ten (10) M4-25L screws when attaching the supply duct to the vertical-horizontal air handler unit.
- To prevent vibration transmission, install flexible connectors between the supply duct and the vertical-horizontal air handler unit. If an electrical heater is included, the flexible connector must be constructed from a heat-resistant material.
- When routed through unconditioned spaces, ducts must be insulated and covered with vapor barriers.
- Internal acoustical insulation lining may be necessary for a metal duct system if it does not have a 90° elbow and ten (10) feet of main duct to the first branch takeoff.
- Fibrous ducts could be used as a substitute if built and installed in accordance with the most recent edition of the Sheet Metal and Air Conditioning Contractors' National Association (SMACNA) Construction Standard.
- Fibrous ducts and acoustical linings must follow National Fire Protection Association (NFPA) Standards 90A or 90B as tested by UL Standard 181 for Class 1 ducts.
- Seal around the ducts to prevent air leaks.

Table 18: VAHU Unit Duct Connection Dimensions Table.

Model No.	Dimensions (inches)							
	A Height	B Width	C Depth	D	E	F	G	H
<b>NJ Chassis</b>								
ARNU123NJA4	48-5/8	18	21-1/4	1-9/16	17-1/2	20	17	12-1/8
ARNU183NJA4								
ARNU243NJA4	48-5/8	18	21-1/4	1-9/16	17-1/2	20	17	12-1/8
ARNU303NJA4								
ARNU363NJA4								
<b>NK Chassis</b>								
ARNU423NKA4	48-5/8	25	21-1/4	1-9/16	24-1/2	20	24	12-1/8
ARNU483NKA4								
ARNU543NKA4								

Figure 22: Attaching Ducts to the Vertical / Horizontal Air Handler Unit.

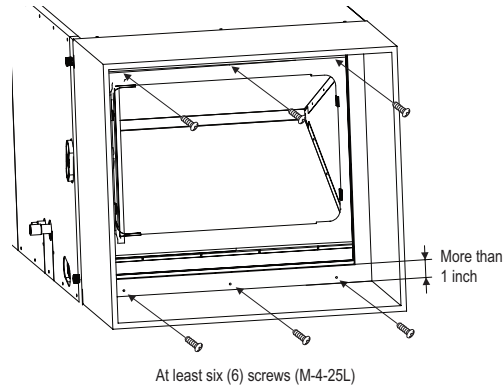
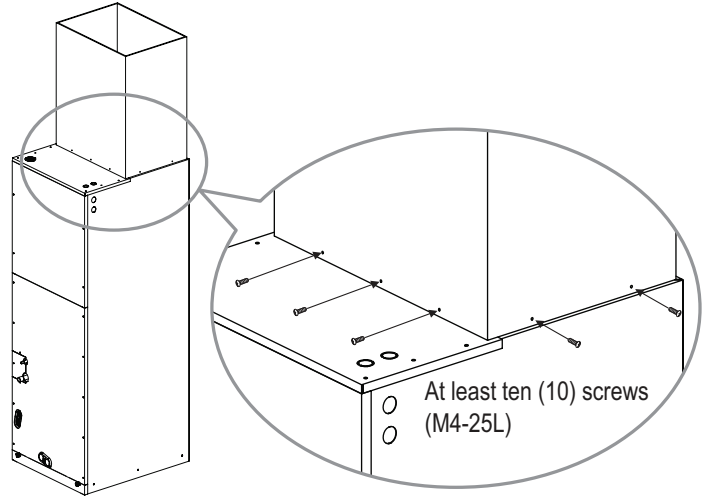
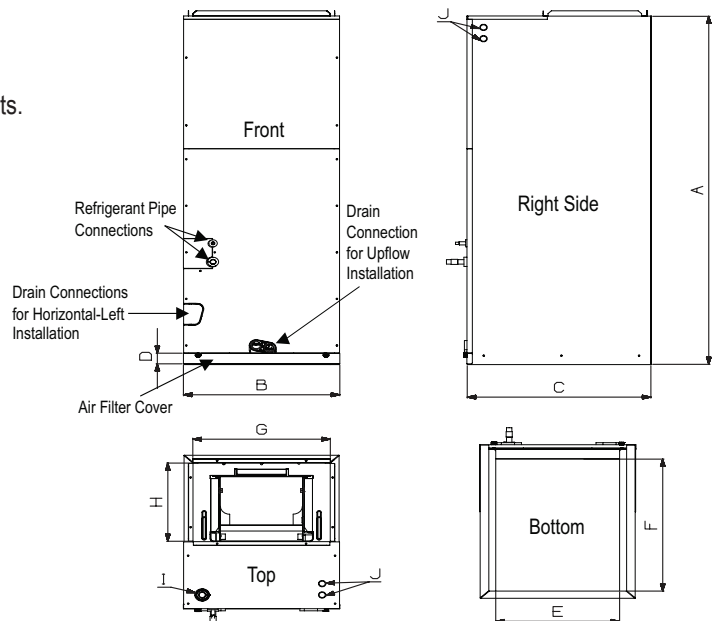
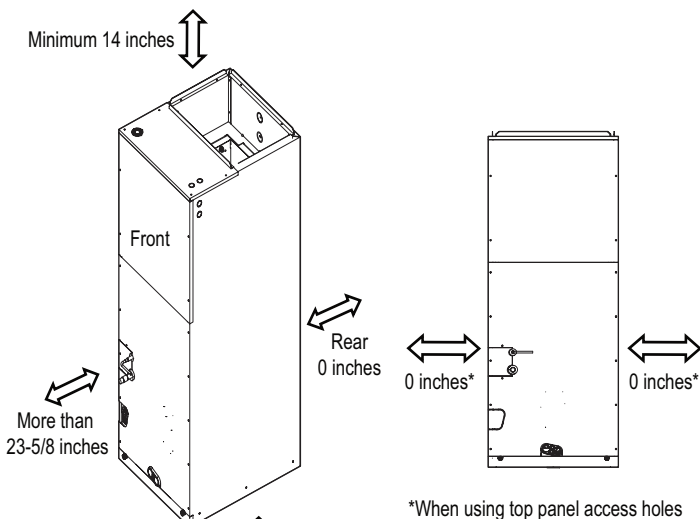

Figure 23: Vertical / Horizontal Air Handler Unit Duct Connection Dimensions Diagram.

Figure 24: Clearances Requirements for Vertical / Horizontal Air Handler Units.



\*When using top panel access holes for power wiring / communications cable  
 Due to our policy of continuous product innovation, some specifications may change without notification.  
 ©LG Electronics U.S.A., Inc., Englewood Cliffs, NJ. All rights reserved. "LG" is a registered trademark of LG Corp.

# INSTALLATION



## Piping Connections

Figure 25: High-Static Ducted (B8) Indoor Unit Piping Connection Dimensions.

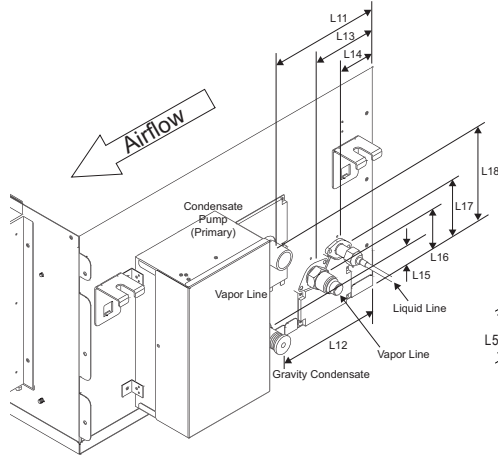

Figure 26: Low-Static Convertible Ducted (L1/L2/L3) Indoor Unit Piping Connection Dimensions.

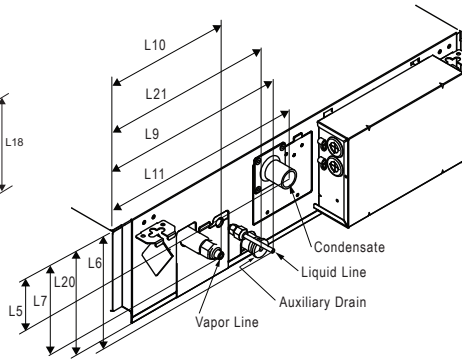

Figure 27: Mid-Static Ducted (M1/M2/M3) and High-Static Ducted (M2/M3) Indoor Unit Piping Connection Dimensions.

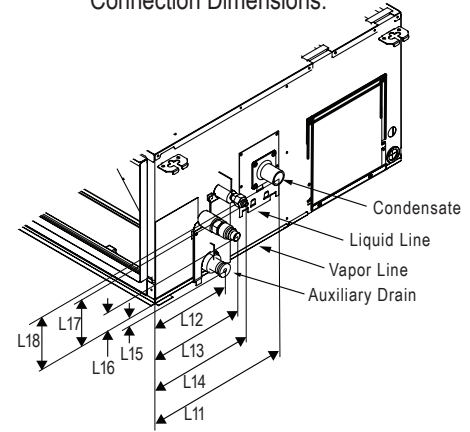

Table 19: Ducted Indoor Unit Pipe Connections (in.).

Size / Chassis	Liquid Line				Vapor Line				Condensate Pump Drain				Gravity Drain (Plugged)			
	Dia. <sup>1</sup>	Conn.	L14	L17	Dia. <sup>1</sup>	Conn.	L13	L16	Dia. <sup>1</sup>	Conn. <sup>2</sup>	L11	L18	Dia. <sup>3</sup>	Conn. <sup>2</sup>	L12	L15
<b>Mid-Static and High-Static Ducted Indoor Units</b>																
7-18 M1	1/4	45° Flare	10-13/32	7-7/32	1/2	45° Flare	8-21/32	5-15/32	1.0	Plain	14-9/32	6-19/32	1.0	3/4 MPT	9-1/4	7/8
24 M2	1/4	45° Flare	10-13/32	7-7/32	5/8	45° Flare	8-21/32	5-15/32	1.0	Plain	14-9/32	6-19/32	1.0	3/4 MPT	9-1/4	7/8
7-18 M2	1/4	45° Flare	10-13/32	7-7/32	1/2	45° Flare	8-21/32	5-15/32	1.0	Plain	14-9/32	6-19/32	1.0	3/4 MPT	9-1/4	7/8
24-42 M2	3/8	45° Flare	10-13/32	7-7/32	5/8	45° Flare	8-21/32	5-15/32	1.0	Plain	14-9/32	6-19/32	1.0	3/4 MPT	9-1/4	7/8
28-54 M3	3/8	45° Flare	7-15/16	7-3/8	5/8	45° Flare	5-5/32	5-1/2	1.0	Plain	12-23/32	6-27/32	1.0	3/4 MPT	6-3/4	1-3/32
36-76 B8	3/8	Brazed	2-1/2	5-1/2	3/4	Brazed	5-1/4	4-3/4	1.0	Plain	7-5/8	6-7/8	1.0	3/4 MPT	7-5/8	1-1/4
96 B8	3/8	Brazed	2-1/2	5-1/2	7/8	Brazed	5-1/4	4-3/4	1.0	Plain	7-5/8	6-7/8	1.0	3/4 MPT	7-5/8	1-1/4
<b>Low-Static Convertible Ducted Indoor Units</b>																
Frame	Liquid Line				Vapor Line				Condensate Pump (Primary)				Auxiliary Drain Connection			
	Dia. <sup>1</sup>	Conn.	L6	L9	Dia. <sup>1</sup>	Conn.	L7	L10	Dia. <sup>1</sup>	Conn. <sup>2</sup>	L5	L11	Dia. <sup>1</sup>	Conn. <sup>2</sup>	L20	L21
L1	1/4	45° Flare	3-7/8	7-1/4	1/2	45° Flare	3-1/2	4-1/2	1.0	Plain	2	11-1/2	1.0	Plain	6-3/8	9-3/4
L2	1/4	45° Flare	3-7/8	7-1/4	5/8	45° Flare	3-1/2	4-1/2	1.0	Plain	2	11-1/2	1.0	Plain	6-3/8	9-3/4
L3	3/8	45° Flare	3-7/8	7-1/4	5/8	45° Flare	3-1/2	4-1/2	1.0	Plain	2	11-1/2	1.0	Plain	6-3/8	9-3/4

<sup>1</sup>Inches I.D.

<sup>2</sup>Plastic Resin

<sup>3</sup>Inches O.D.

## Refrigerant Safety

### ⚠ WARNING

Verify the maximum refrigerant concentration in the space where the indoor unit will be mounted meets the concentration limit allowed by ASHRAE Standards 15-2010 and 34-2010. There is danger of asphyxiation from oxygen displacement.

ASHRAE Standards 15-2010 and 34-2010 offer guidelines that address refrigerant safety and the maximum allowable concentration of refrigerant in an occupied space. Refrigerant will dissipate into the atmosphere, but a certain volume of air is required for this to occur safely. For R410A refrigerant, the maximum allowable concentration of refrigerant is twenty-six (26) lbs. per 1,000 cubic feet of an occupied space. Buildings with twenty-four (24) hour occupancy allow half of that concentration.<sup>1</sup>

ASHRAE Standards 15 and 34 assume that if a system develops a leak, its entire refrigerant charge will dump into the area where the leak occurs. To meet ASHRAE Standards 15 and 34, calculate the refrigerant concentration that may occur in the smallest room volume on the system, and compare the results to the maximum allowable concentration number.<sup>1</sup> Also consult state and local codes in regards to refrigerant safety.

<sup>1</sup>Information about ASHRAE Standard 15-2010 / 34-2010 and addenda current as of the date of this publication.



Multi V Ducted Indoor Units



Piping Preparation

**⚠ WARNING**

Do not braze in an enclosed location. Do not allow the refrigerant to leak during brazing. Always test for gas leaks before and after brazing.

• If refrigerant combusts, it generates a toxic gas.

**Note:**

•  Do not use kinked pipe.

Braze the pipe to the service valve pipe stub of the outdoor unit. After brazing, check for refrigerant gas leaks. When selecting flare fittings, always use a 45° fitting rated for high-pressure refrigerant R410A. Fittings must also comply with local, state, and federal standards.

**Creating a Flare Fitting**

One of the main causes of refrigerant leaks is defective flared connections. Use the following procedure to create flared connections.

1. Determine the installation location. Ensure the location has enough space to allow necessary duct connections and maintenance access.
  - Measure the distance between the indoor unit and the outdoor unit.
  - Cut the pipes a little longer than measured distance.
- 2A. Remove the burrs.
  - Completely remove all burrs from pipe ends.
  - When removing burrs, point the end of the copper pipe down to avoid introducing foreign materials into the pipe.
- 2B. Slide the flare nut onto the copper tube.
3. Flare the pipe end.
  - Use the proper size flaring tool to finish flared connections as shown.
  - ALWAYS create a 45° flare when working with R410A.
4. Carefully inspect the flared pipe end.
  - Compare the geometry with the figure to the right.
  - If the flare is defective, cut it off and re-do procedure.
  - If flare looks good, blow the pipe clean with dry nitrogen.

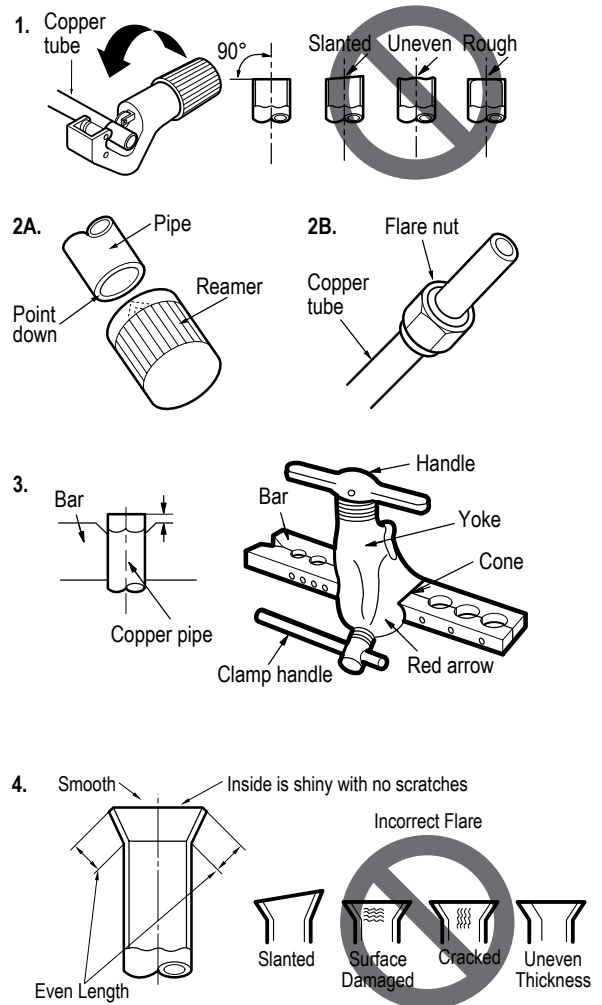

Dimensions of the Flare.

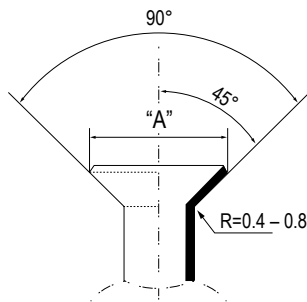

Pipe Size (in. O.D.)	Outside Diameter (mm)	"A" Dimension (mm [in.])
1/4	6.35	~ 9.1 (11/32 - 23/64)
3/8	9.52	~ 13.2 (1/2 - 33/64)
1/2	12.7	~ 16.6 (41/64 - 21/32)
5/8	15.88	~ 19.7 (49/64 - 25/32)
3/4	19.05	—

## Tightening Flare Nuts

1. When connecting the flare nuts, coat the flare (outside only) with polyvinyl ether (PVE) refrigeration oil only.

### Note:

• Do not use polyolyester (POE) or any other type of mineral oil as a lubricant. These lubricants are not compatible with PVE oil used in this system and create oil sludge leading to equipment damage and system malfunction..

2. Initially hand tighten the flare nuts using three (3) or four (4) turns.

3. To finish tightening the flare nuts, use both a torque wrench and a backup wrench.

4. After all the piping has been connected and the caps have been tightened, check for refrigerant gas leaks

## Loosening Flare Nuts

Always use two (2) wrenches to loosen flare nuts.

Pipe Size (in. O.D.)	Outside Diameter (mm)	Tightening Torque (ft-lbs.)
1/4	6.35	13.0 - 18.0
3/8	9.52	24.6 - 30.4
1/2	12.7	39.8 - 47.7
5/8	15.88	45.4 - 59.3
3/4	19.05	71.5 - 87.5

Keep Pipes Capped While Storing.

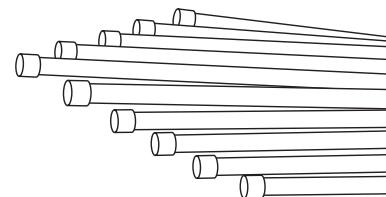

## Piping Materials and Handling

Pipes used for the refrigerant piping system must include the specified thickness, and the interior must be clean. While handling and storing, do not bend or damage the pipes, and take care not to contaminate the interior with dust, moisture, etc.

Keep refrigerant pipe dry, clean, and airtight.

	Dry	Clean	Airtight
	No moisture should be inside the piping.	No dust should be inside the piping.	No leaks should occur.
<b>Possible Problems</b>	<ul style="list-style-type: none"> <li>- Significant hydrolysis of refrigerant oil.</li> <li>- Refrigerant oil degradation.</li> <li>- Poor insulation of the compressor.</li> <li>- System does not operate properly.</li> <li>- EEVs, capillary tubes are clogged.</li> </ul>	<ul style="list-style-type: none"> <li>- Refrigerant oil degradation.</li> <li>- Poor insulation of the compressor.</li> <li>- System does not operate properly.</li> <li>- EEVs and capillary tubes become clogged.</li> </ul>	<ul style="list-style-type: none"> <li>- Refrigerant gas leaks/shortages.</li> <li>- Refrigerant oil degradation.</li> <li>- Poor insulation of the compressor.</li> <li>- System does not operate properly.</li> </ul>
<b>Solutions</b>	<ul style="list-style-type: none"> <li>- Remove moisture from the piping.</li> <li>- Piping ends should remain capped until connections are complete.</li> <li>- Do not install piping on a rainy day.</li> <li>- Connect piping properly at the unit's side.</li> <li>- Remove caps only after the piping is cut, the burrs are removed, and after passing the piping through the walls.</li> <li>- Evacuate system to a minimum of 500 microns and ensure the vacuum holds at that level for 1 hour.</li> </ul>	<ul style="list-style-type: none"> <li>- Remove dust from the piping.</li> <li>- Piping ends should remain capped until connections are complete.</li> <li>- Connect piping properly at the side of the unit.</li> <li>- Remove caps only after the piping is cut and burrs are removed.</li> <li>- Retain the cap on the piping when passing it through walls, etc.</li> </ul>	<ul style="list-style-type: none"> <li>- Test system for air tightness.</li> <li>- Perform brazing procedures that comply with all applicable standards.</li> <li>- Perform flaring procedures that comply with all applicable standards.</li> <li>- Perform flanging procedures that comply with all applicable standards.</li> <li>- Ensure that refrigerant lines are pressure tested to 550 psig for 24 hours.</li> </ul>

## Refrigerant Safety

### **⚠ WARNING**

Verify the maximum refrigerant concentration level in the space where the indoor unit will be mounted meets the concentration limit for the application. There is risk of asphyxiation from oxygen depletion.

ASHRAE Standards 15-2010 and 34-2010 offer guidelines that address refrigerant safety and the maximum allowable concentration of refrigerant in an occupied space. Refrigerant will dissipate into the atmosphere, but a certain volume of air is required for this to occur safely. For R410A refrigerant, the maximum allowable concentration of refrigerant is twenty-six (26) lbs. per 1,000 cubic feet of an occupied space. Buildings with twenty-four (24) hour occupancy allow half of that concentration.<sup>1</sup>

ASHRAE Standards 15 and 34 assume that if a system develops a leak, its entire refrigerant charge will dump into the area where the leak occurs. To meet ASHRAE Standards 15 and 34, calculate the refrigerant concentration that may occur in the smallest room volume on the system, and compare the results to the maximum allowable concentration number.<sup>1</sup> Also consult state and local codes in regards to refrigerant safety.

<sup>1</sup>Information about ASHRAE Standard 15-2010/34-2010 and addenda current as of the date of this publication.

## Brazing

### **Note:**

It is imperative to keep the piping system free of contaminants and debris such as copper burrs, slag, or carbon dust during installation.

1. All joints are brazed in the field. Multi V refrigeration system components contain very small capillary tubes, small orifices, electronic expansion valves, oil separators, and heat exchangers that can easily become blocked. Proper system operation depends on the installer using best practices and utmost care while assembling the piping system.
  - Store pipe stock in a dry place and keep stored pipe capped and clean.
  - Purge all pipe sections clean with dry nitrogen prior to assembly.
2. Proper system operation depends on the installer using best practices and the utmost care while assembling the piping system.
  - Use adapters to assemble different sizes of pipe.
  - Always use a non-oxidizing material for brazing. Do not use flux, soft solder, or anti-oxidant agents. If the proper material is not used, oxidized film may accumulate and clog or damage the compressors. Flux can harm the copper piping or refrigerant oil.
  - Use a tubing cutter; do not use a saw to cut pipe. De-bur and clean all cuts before assembly.
3. Brazing joints:
  - Use a dry nitrogen purge operating at a maximum pressure of three (3) psig and maintain a steady flow.
  - Use a 15% silver phosphorous copper brazing alloy to avoid overheating and produce good flow.
  - Protect isolation valves, electronic expansion valves, and other heat-sensitive control components from excessive heat with a wet rag or heat barrier spray.

Figure 28: Using Nitrogen Gas During Brazing

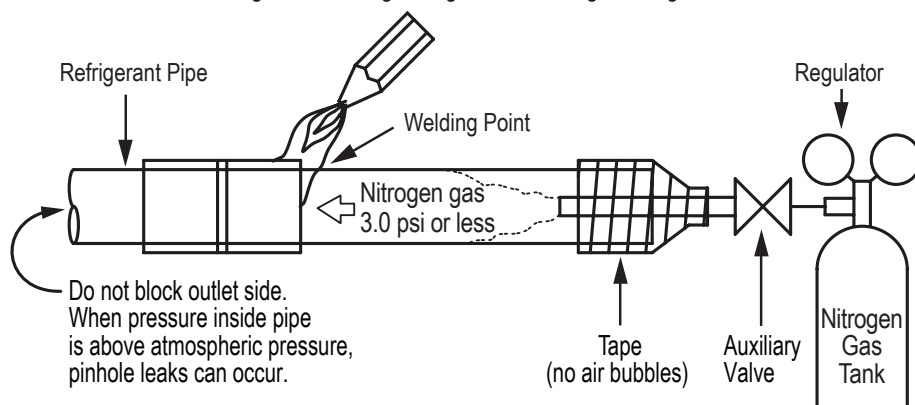

A properly installed pipe system will have sufficient support so that pipes will not sag during the life of the system. As necessary, place supports closer for segments where potential sagging could occur. Maximum spacing of pipe supports must meet local codes.

Figure 29: Pipe Support at Indoor Unit.

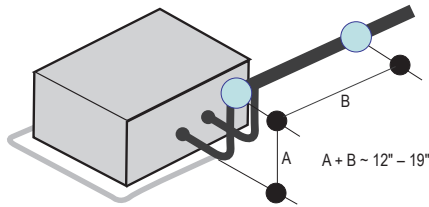

Figure 33: Pipe Support at Header Fitting.

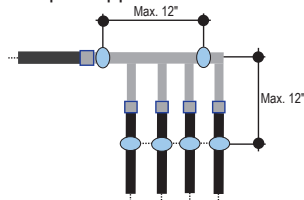

Figure 30: Typical Pipe Support Location—Change in Pipe Direction.

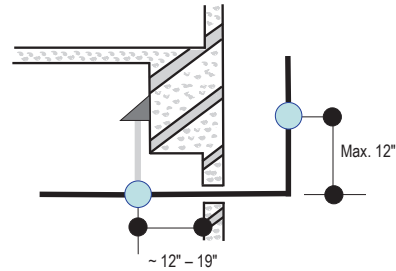
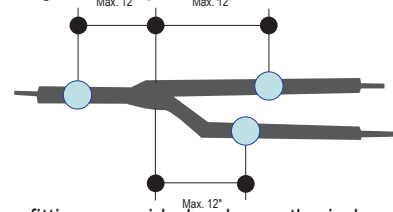

Figure 34: Pipe Support at Y-branch Fitting.



## Refrigerant Pipe Connections

Indoor units come with flare type connections. It is the installer's option to use the flare fittings provided or braze the indoor unit to the refrigerant piping system. The vertical air handling unit (VAHU) comes with brazed connections only.

### Flare Fittings

- All unit flare fittings are 45° and rate for high-pressure R410A refrigerant.
- Properly form all flare fittings using best practices.
- Place a drop of PVE oil on the outside of the flare fitting before tightening.

### Note:

- Do not use any other type of oil (including traditional POE refrigeration oil) as a lubricant. Failure to follow this procedure may lead to restrictions in the refrigeration components.
- Do not over-tighten flare nuts. Excessive tightening will cause fittings to crack.

### Note:

Multi V refrigeration system components contain very small capillary tubes, small orifices, electronic expansion valves, oil separators, and heat exchangers that can easily become blocked.

## Insulate Refrigerant Pipes

Sufficiently insulate all cold surfaces to prevent moisture forming. All pipes must be insulated and each pipe must be separately wrapped. Refer to Figure 31 and Figure 32. Use field-provided one-half (1/2) inch thick (or thicker) closed-cell insulation. The thickness may need to be increased based on ambient conditions and local codes.

Wrap all refrigerant piping including field-provided isolation ball valves and flexible pipe connection kits provided by LG. Glue all insulation joints with no air gaps between insulation segments, and between insulation segments and the unit case. Ensure insulation material fits snugly against the refrigeration pipe with no air space between the pipe surface and the surrounding insulation.

Protect insulation inside hangers and supports with a second insulation layer. Ensure insulation on all pipe passing through pipe hangers, inside conduit, and/or sleeves is not compressed.

Figure 31: Typical Refrigerant Line Flare Fitting Insulation Detail

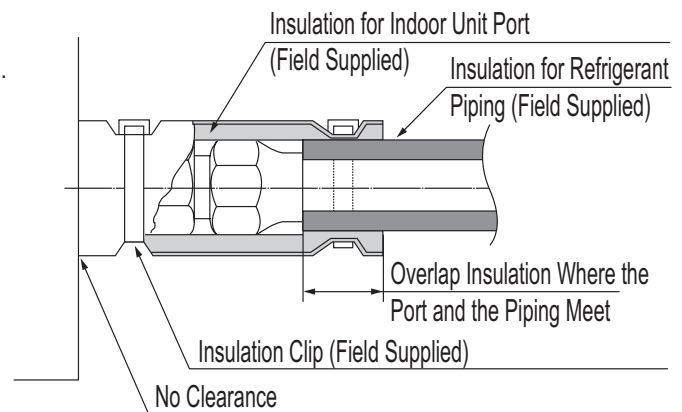
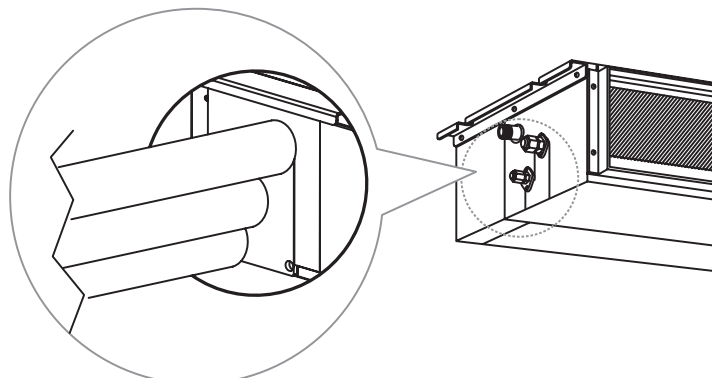

Figure 32: No Air Gap in Pipe Insulation to Indoor Unit Frame.



All ducted indoor units except the vertical air handler have a factory-mounted condensate pump that runs continuously while the unit is in cooling mode. The pump has an internal high-level float switch that stops the unit if the water level in the pan rises too high.

All ducted indoor units have a flexible drain hose kit and one or two clamps. The hose can be used to connect the condensate pipe to the condensate pump connection. On mid and high-static units, there is the option to directly connect a 3/4 inch FPT fitting to the drain pan's gravity drain connection.

**Note:**

⊗ When making condensate pipe connections, be careful not to exert lateral force on the drain nipple. Internal damage may occur. Refer to Table 19 for condensate pipe connection sizes.

**Condensate Pump Connection**

All ducted units have a condensate pump except the VAHU. Note the following when connecting the condensate pipe to the unit (Figure 35).

- Indoor units DO NOT come with check valves or a backflow prevention device. If check valves are needed, they must be field supplied.
- The maximum lift of all condensate pumps is 27 in.-wg.
- Measure lift distance from the bottom surface of the indoor unit, NOT from the condensate pipe connection.
- Slope all horizontal condensate pipe segments a minimum of 1/4 inch per foot away from the indoor unit.

**Ducted Unit Drain Information**

When the bottom surface of the indoor unit is at an elevation below the receiving building drain line connection, install an inverted trap at the top of the condensate pump discharge riser before connection to the building drain pipe.

When the receiving drain line is mounted horizontal, connect the inverted trap to the top half of the pipe. The connection point of the inverted trap to the building drain pipe should always be to the top half of the pipe and should never be over 45° either side of the upper most point of the horizontal building drain line.

If connecting to a vertical drain line or plumbing system vent line, connect the IDU condensate pump discharge line using a Y-45 fitting with the double end of the Y-45 fitting facing up. When connecting to a vertical drain line include an inverted trap at the top of the IDU condensate pump discharge riser before connection to the Y-45 fitting.

**Gravity Condensate Pipe Connection**

Mid-static (M1/M2/M3) and High-static indoor units (M2/M3/B8) have an auxiliary gravity condensate drain connection just below the condensate pump pipe connection on the control panel end of the unit. This connection may be used instead of using the condensate pump. If the gravity drain is used, disconnect the IDU condensate pump connector on the IDU PCB.

- Verify the unit is installed with a slight cant toward the gravity drain connection.
- Remove the rubber plug before connecting the condensate line to the indoor unit.
- The gravity condensate line must be equipped with a condensate trap for proper condensate flow (B8 only). M1, M2 and M3 units do not require a trap. Refer to Figure 36 for trap details.
- All horizontal segments of condensate pipe should be sloped a minimum of 1/4 inch per foot away from the indoor unit.



Use materials acceptable by local code. Due to our policy of continuous product innovation, some specifications may change without notification. © LG Electronics U.S.A., Inc., Englewood Cliffs, NJ. All rights reserved. "LG" is a registered trademark of LG Corp.

Table 20: Indoor Unit Drainage Specifications.

Indoor Unit	Drain Type	Drain Pipe Dia. (ID, in.)
B8, M1, M2, M3 Frame Mid Static Ducted and High Static Ducted	27 in. Lift Drain Pump, Factory Installed	Ø1
L1, L2, L3 Frame Low Static Ducted		
NJ, NK Frame Vertical/Horizontal Air Handler Unit	Gravity	Ø1

Figure 35: High Static, Mid Static, Low Static, Built In Ducted Indoor Unit Drain Pump to Drain Piping System

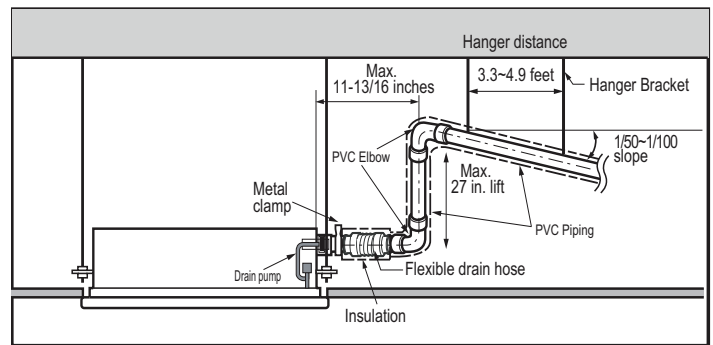
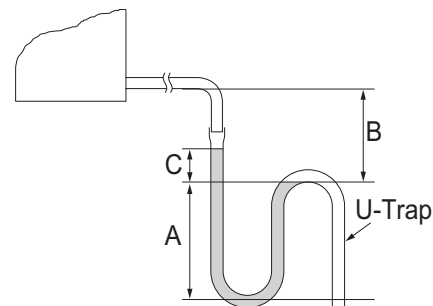

Figure 36: Gravity Condensate Trap..



Where:

A = 2-1/2"

B ≥ 2 x C

C ≤ 2 x External Static Pressure (in.-wg)

## Vertical/Horizontal Air Handler Unit Drain Information

### Note:

Install a field-supplied external condensate pan underneath the entire vertical air handler unit to avoid damage due to condensate overflow.

Vertical / Horizontal Air Handler units have a gravity drain.

- Avoid blocking filter access panel when connecting drain lines.
- An additional external condensate line should run from the unit into the pan.
- The entire condensate line should be drained from the external condensate pan.
- Point the drain hose downward for easy drain flow.
- Do not use pipe joint connection or PVC/CPVC for the unit drain line connection. Use Teflon® tape.

## Install the Condensation Drain Pipe

- Drain piping must slope down or flow may reverse back to unit.
  - During drain piping connection, be careful not to exert extra force on the drain port on the indoor unit.
  - Refer to Table 19 for drain pipe sizing.
  - Use polyvinyl chloride pipe.
1. Refer to Figure 39 and plan the drain pipe routing so that the pipe will slope downward from the indoor unit to its end drain location.
  2. Connect the provided flexible drain pipe to the main drain pipe.
  3. Pour water into the flexible pipe as shown in Figure 41 to test for leaks. Repair leaks if necessary.

Figure 39: Drain Piping Slope.

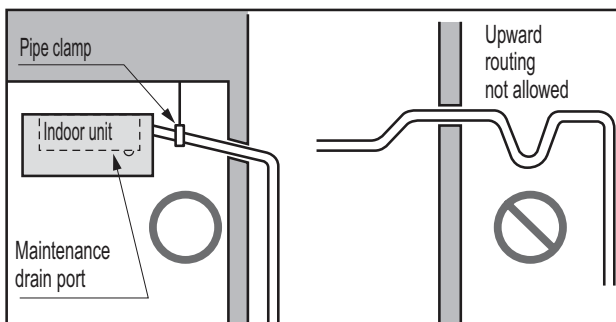

4. Route the flexible drain pipe to the indoor unit and connect the flexible drain pipe to the drain port of the indoor unit.
5. Install field supplied polyethylene foam insulation 5/16 inch thick or greater on the flexible drain pipe and position snugly against indoor unit.

Figure 40: Do Not Sharply Bend Drain Pipe.

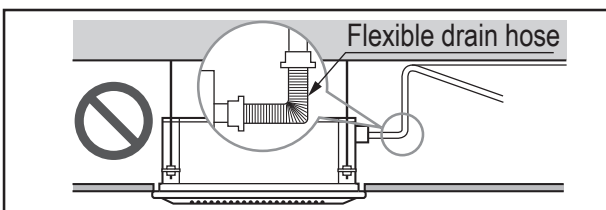

Figure 37: Vertical / Horizontal Air Handler Unit Drain Piping System.

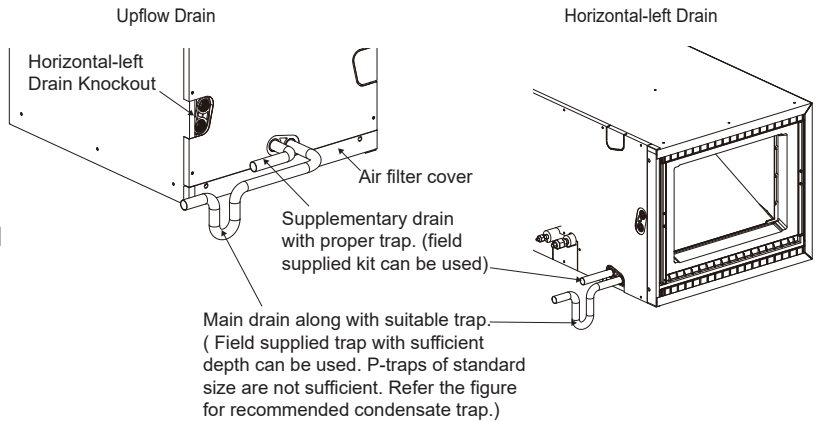

Figure 38: Vertical / Horizontal Air Handler Unit U-Trap Specifications.

- Install the U-Trap to prevent leaks caused by blocking the intake air filter.

### Applied U-Trap Dimensions

- A ≥ 2-9/16 inch
- B ≥ 2C
- C ≥ 2 x SP
- SP = External Pressure (in. WG)
- Ex) External Pressure = 0.4 in. WG
- A ≥ 2-9/16 inches
- B ≥ 1-7/12 inches
- C ≥ 13/16 inches

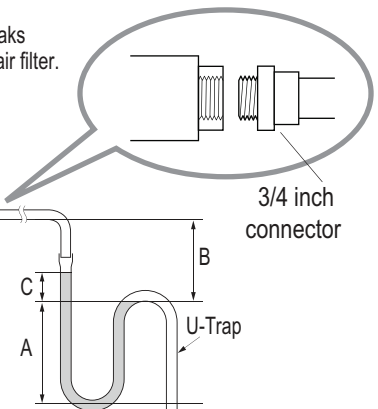
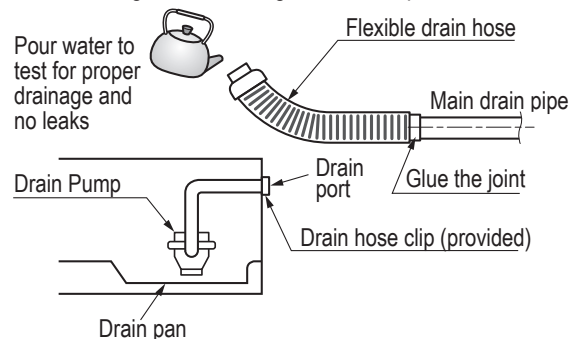

Figure 41: Testing the Drain Pipe.



**⚠ WARNING**

- All power wiring and communication cable installation must be performed by authorized service providers working in accordance with local, state, and National Electrical Code (NEC) regulations related to electrical equipment and wiring, and following the instructions in this manual. Failure to do so will lead to electric shock and bodily injury or death.
- Be sure that main power to the unit is completely off before proceeding. Follow all safety and warning information outlined at the beginning of this manual. Failure to do so will cause electric shock and bodily injury.
- Familiarize yourself with the location of the circuit breaker. Be sure that a circuit breaker or some other emergency power cutoff device is in place before any power wiring is done to the system. Failure to do so will cause bodily injury or death.
- ⓧ Never touch any power lines or live cables before all power is cutoff to the system. To do so, will cause bodily injury or death.
- Undersized wiring will lead to unacceptable voltage at the unit and will cause a fire, which will cause bodily injury or death.
- Properly ground all outdoor units and indoor units. Ground wiring must always be installed by a qualified technician. Ground wiring is required to prevent accidental electrical shock during current leakage, which will cause bodily injury or death.
- Install appropriately sized breakers / fuses / overcurrent protection switches and wiring in accordance with local, state, and NEC regulations related to electrical equipment and wiring, and following the instructions in this manual. Generated overcurrent could include some amount of direct current. Using an oversized breaker or fuse will result in electric shock, physical injury or death.
- ⓧ Do not connect ground wire to refrigerant, gas, or water piping; to lightning rods; to telephone ground wiring; or to the building plumbing system. Failure to properly provide a NEC-approved earth ground can result in electric shock, physical injury or death.

**Note:**

- The information contained in this manual is intended for use by a trained electrician familiar with applicable local codes and the U.S. National Electric Code (NEC), and who is equipped with the proper tools and test instruments. Failure to carefully read and follow all instructions in this manual can result in equipment malfunction or property damage.
- Consider ambient conditions (temperature, direct sunlight, inclement weather, etc.) when selecting, installing, and connecting the power wiring.
- Properly ground all outdoor units and indoor units. Ground wiring must always be installed by a qualified technician. Improperly ground wire can cause communication problems from electrical noise, and motor current leakage.
- If there is a possibility of reversed phase, phase loss, momentary blackout, or the power goes on and off while the system is operating, install a field-supplied phase loss protection circuit. If the system operates in reversed phase, etc., it will damage the compressors and other components.
- Install appropriately sized breakers / fuses / overcurrent protection switches and wiring in accordance with local, state, and NEC regulations related to electrical equipment and wiring, and following the instructions in this manual. Generated overcurrent will include some amount of direct current. Using an oversized breaker or fuse will result in equipment malfunction and property damage.
- ⓧ Do not connect ground wire to refrigerant, gas, or water piping; to lightning rods; to telephone ground wiring; or to the building plumbing system. Failure to properly provide a NEC-approved earth ground can result in property damage and equipment malfunction.

**Separating Power Wiring and Communication Cables**

- ⓧ Avoid running the power wiring and communication cable alongside each other; there is a strong likelihood of operation malfunction due to electrostatic and electromagnetic interference. ⓧ Do not run both in the same conduit.
- If running the power wiring and communication cable alongside each other cannot be avoided, see the table below for minimum required distances.

Table 21: Power Wire and Communications Cable Minimum Required Separation Allowable Distances.

Capacity of Power Supply Wiring (current)		Minimum Required Distance <sup>1,2</sup>
100V or more	10A	12 inches
	50A	20 inches
	100A	40 inches
	Exceeding 100A	60 inches

<sup>1</sup>The figures above are based on parallel lengths up to 328 feet long. For lengths in excess of 328 feet, the distances will have to be recalculated in direct proportion to the additional line lengths involved.

<sup>2</sup>If the power supply waveform continues to exhibit some distortion, the space between the power wiring and communication cable must be increased.

**Note:**

- ⓧ Do not secure the power wiring and communication cables together. It will result in equipment malfunction.
- ⓧ Do not run the power wiring and the communication cable in the same conduit. It will result in equipment malfunction.



### Power Wiring / Communication Cable Connections

Best practice dictates using solderless ring or fork terminals at all power wiring and communication cable terminations. Use copper bearing ring or fork terminals; do not use galvanized or nickel plate over steel. Use appropriate crimping tool to attach the ring or fork terminals at all power wiring and control cable terminations. To install:

- Firmly attach the wire; secure in a way to prevent external forces from being imparted to the terminal block.
- Use an appropriately sized JIS screwdriver for tightening the terminals.
- Do not overtighten the connections; overtightening will damage the terminals.

If ring terminals or fork terminals are not available, then:

- Do not terminate different gauge wires to the power terminal block. (Slack in the wiring will generate heat.)
- When terminating wires of the same thickness, follow the instructions demonstrated in the figures below.

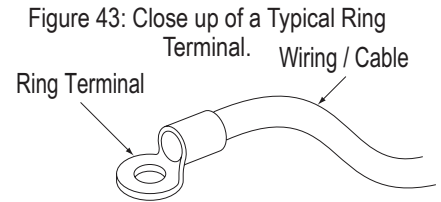
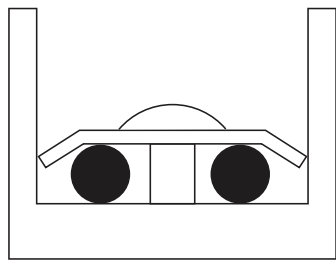
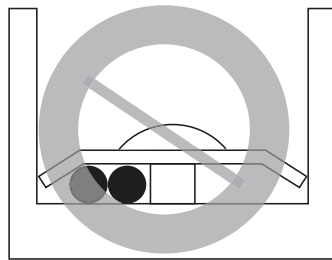

Figure 44: Proper and Improper Power Wiring Connections.



Terminate multiple power wires of the same gauge to both sides.



Do not terminate two wires on one side.

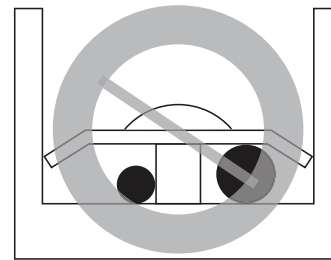

Do not terminate different gauge wires to a terminal block.

● :Copper Wire

### WARNING

If power wires are not properly terminated and firmly attached, there is risk of fire, electric shock, and physical injury or death.

### Note:

- Never apply line voltage power to the communications cable terminal block. If contact is made, the PCBs will be damaged.
- Always include some allowance in the wiring length when terminating. Firmly attach the wiring or cable, but provide some slack to facilitate removing the electrical panels while servicing, and to prevent external forces from damaging the terminal block.

### Terminal Connections

LG uses a “JIS” type of screw for all terminals; use a JIS screwdriver to tighten and loosen these screws and avoid damaging the terminal. Do not overtighten the connections — overtightening will damage the terminals — but firmly and securely attach the wiring in a way to prevent external forces from being imparted to the terminal block.

### Note:

- The terminals labeled “GND” are NOT ground terminals. The terminals labeled ARE ground terminals.
- Polarity matters. Always connect “A” to “A” and “B” to “B.”
- Always create a wiring diagram that contains the exact sequence in which all the indoor units (and heat recovery units) are wired in relation to the outdoor unit.
- Do not include splices or wire nuts in the communication cable.

Figure 42: JIS Screws.

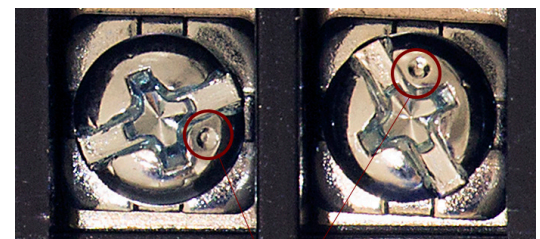

JIS DIMPLES



## Power Supply / Power Wiring Specifications

Outdoor unit(s) and indoor units / heat recovery units must be provided power from separate breakers. For detailed information, see the Multi V Outdoor Unit Engineering and Installation Manuals on [www.lghvac.com](http://www.lghvac.com).

### Indoor Units (and Heat Recovery Units)

- Indoor units (and heat recovery units) require 1Ø, 208-230V, 60Hz power, but each unit draws minimal power.
- Where permitted by NEC and local codes, multiple indoor units (and heat recovery units) can be powered from a single breaker.
- Service switches typically must be installed for each indoor unit (and each heat recovery unit).
- Ground each indoor unit (and heat recovery unit) separately to a solid earth ground source per NEC and local code requirements.

### **⚠ WARNING**

- *All power wiring installation must be performed by trained service providers working in accordance with local, state, and NEC regulations related to electrical equipment and wiring, and following the instructions in this manual. Failure to do so will lead to electric shock and bodily injury or death.*
- *Use specified wiring for connections, and ensure that external force is not imparted to terminal connections. If connections are too firmly attached, it will generate heat and / or cause a fire, resulting in physical injury or death.*
- *Install appropriately sized breakers / fuses / overcurrent protection switches and wiring in accordance with local, state, and NEC regulations related to electrical equipment and wiring, and following the instructions in this manual. Generated overcurrent will include some amount of direct current. Using an oversized breaker or fuse will result in electric shock, physical injury or death.*
- *Use the appropriate type of overcurrent protection. Generated overcurrent will include some amount of direct current, and if the appropriate type of overcurrent protection is not installed, there is a risk of fire, electric shock, and physical injury or death.*
- *Ground wiring is required to prevent accidental electrical shock during current leakage, communication problems from electrical noise, and motor current leakage. Ⓝ Do not connect the ground line to the pipes. There is risk of fire, electric shock, explosion, physical injury or death.*
- *Install a main shutoff switch that interrupts all power sources simultaneously. There is risk of fire, electric shock, explosion, physical injury or death.*

### **Note:**

- *Install appropriately sized breakers / fuses / overcurrent protection switches and wiring in accordance with local, state, and NEC regulations related to electrical equipment and wiring, and following the instructions in this manual. Generated overcurrent could include some amount of direct current. Using an oversized breaker or fuse will result in equipment malfunction and property damage.*
- Ⓝ *Do not connect ground wire to refrigerant, gas, or water piping; to lightning rods; to telephone ground wiring; or to the building plumbing system. Failure to properly provide a National Electrical Code-approved earth ground can result in property damage and equipment malfunction.*

### Communication Cable Specifications From Outdoor Unit to Indoor Units / Heat Recovery Units

- Communication cable from Main Outdoor Unit to Indoor Units / Heat Recovery Units is to be LG supplied or field supplied 18 AWG, 2-conductor, twisted, stranded, shielded. Never splice communications cable. Ensure the communication cable shield is properly grounded to the Main Outdoor Unit chassis only. ⚠ Do not ground the Outdoor Unit to Indoor Units / Heat Recovery Units communication cable at any other point. Wiring must comply with all applicable local and national codes.
- Cable shields between the connected devices must be tied together and continuous from the main outdoor unit to the last component connected and insulated to prevent grounding against the IDU/HRU electrical enclosures.
- Start the communication cable at the main outdoor unit and route to the indoor units / heat recovery units in a daisy chain configuration. ⚠ Do not install in a starburst configuration.
- Indoor Unit / Heat Recovery Unit Communication Bus: The communication terminals are labeled differently among the indoor units, depending on type (currently for indoor units: A / B, 3[A] / 4[B], or 3 / 4; for heat recovery units: A / B). Refer to the wiring diagram schematic found in the indoor unit itself, or to the indoor unit wiring diagrams for more information. Match IDU A and B terminals on outdoor unit to A (3) and B (4) terminals on indoor units / heat recovery units.
- Insulation as required by NEC and local codes.
- Rated for continuous exposure of temperatures up to 140°F.
- Maximum allowable communication cable length is 3,281 feet.

#### ⚠ WARNING

- Ground wiring is required to prevent accidental electrical shock during current leakage, communication problems from electrical noise, and motor current leakage. ⚠ Do not connect the ground line to the pipes. There is risk of fire, electric shock, explosion, physical injury or death.
- ⚠ Never ground the shield of the communications cable to the indoor unit frame or other grounded entities of the building. Inadequate connections will generate heat, cause a fire, and physical injury or death.

#### Note:

- Always verify the communication cable is connected to a communications terminal on the outdoor unit(s). ⚠ Never apply line voltage power to the communication cable connection. If contact is made, the PCBs will be damaged.
- ⚠ Never use a common multiple-core communications cable. Each communications bus shall be provided a separate cable (i.e., between outdoor unit(s) and indoor units, outdoor units and central controller(s)). If communications cables of separate systems are wired using a common multiple-core cable, it will result in a poor communications signal and unacceptable system operation.

Figure 45: Correct Main Outdoor Unit to Indoor Unit / Heat Recovery Unit Communication Wiring—Typical Daisy Chain Configuration.

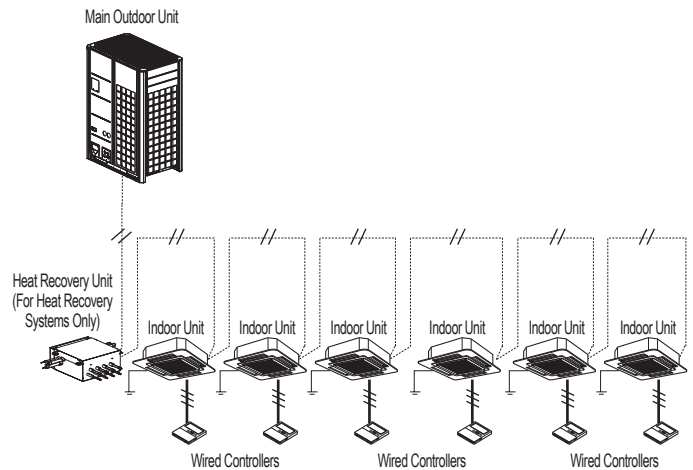
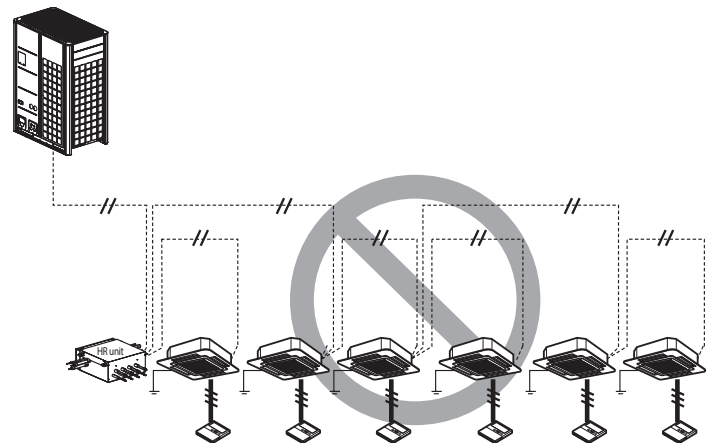

Figure 46: Incorrect Main Outdoor Unit to Indoor Unit / Heat Recovery Unit Communication Wiring—Starburst Configuration.



## Communications Cable Specifications From Indoor Units to Remote Controllers

- Communication cable from Indoor Unit to Remote Controller(s) is to be LG supplied or field supplied 22 AWG, 3-conductor, twisted, stranded, unshielded. Wiring must comply with all applicable local and national codes.
- If using LG supplied cable and the length needs to be extended, the LG Extension Kit (sold separately) must be used. A maximum of four (4) kits (up to 165 feet) can be used.
- Remote Controllers have hardwired connections: SIG - 12V - GND (Comm.) terminals.
- Indoor unit controller connections depend on type of indoor unit being installed. Some indoor units use terminal block connections; other indoor units use Molex connections. See diagrams below for the two options. Refer to the wiring diagram schematic found in the indoor unit itself, or to the indoor unit wiring diagrams in the Engineering Manuals for more information.
- ⚠ NEVER splice, cut, or extend LG supplied cable with field provided cable. Always include enough cable to cover distance between the indoor unit and the remote controller.
- Set the indoor unit operating parameters using DIP switches, or by setting up the remote controller. Refer to the remote controller installation manual for more details.

Figure 47: One Example of Indoor Unit to Zone Controller Connection.

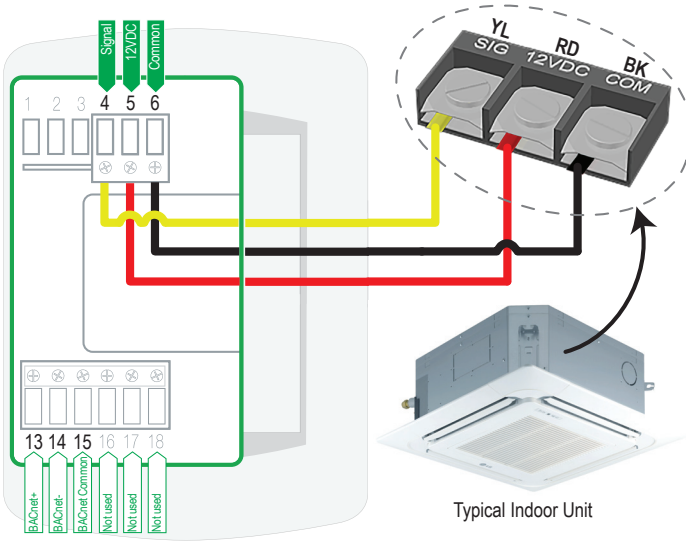
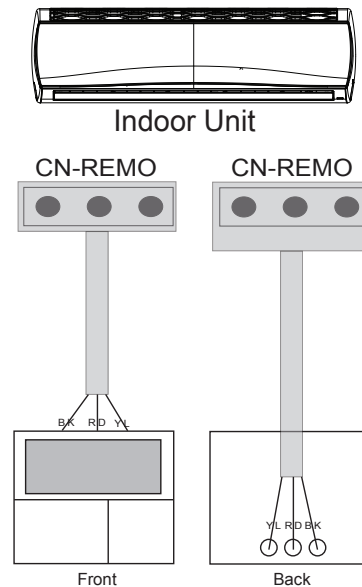

Figure 48: Another Example of Indoor Unit to Zone Controller Connection.



**Note:**

*Cable connected to Zone Controller is the factory default connection.*

### Communications Cable Specifications Between Multiple Indoor Units Operating as a Group (Group Control)

#### If any indoor units were specified to operate in unison:

- Before running cable, decide which indoor unit will be the “Main.” The other indoor units in that group will be designated as “Sub(s).” The zone controller will be connected to the “Main.”
- Set the pertinent DIP switch at each indoor unit to identify the Main and Sub(s).
- Use a daisy chain configuration and connect all of the group’s indoor units together starting at the “Main” unit.
- **⊘ NEVER** splice, cut, or extend LG provided cable with field provided cable. Always include enough cable to cover distance between all components.
- Perform group control settings and connect the group control wiring after the system auto address and auto pipe procedures have been completed.

Figure 49: Example of Indoor Unit Group to Zone Controller Connections (Sig-12V-GND [Comm.] Terminal).

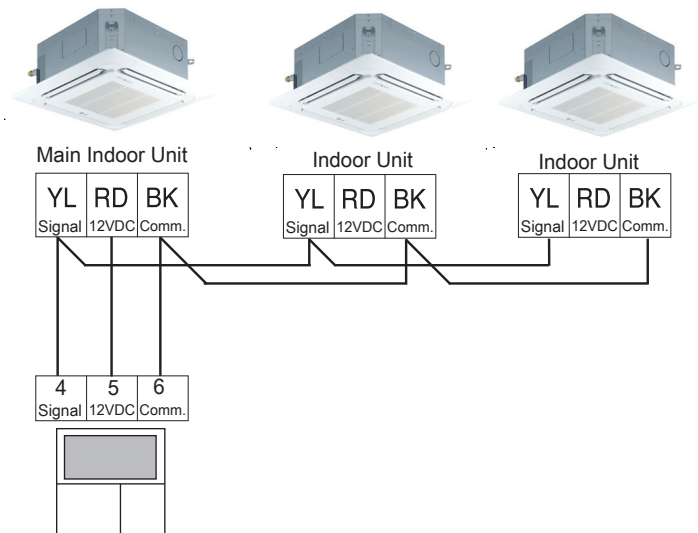

#### For indoor units with hardwired connections SIG - 12V - GND (Comm.) terminals:

- From the controller to the main indoor unit, use 22 AWG, 3-conductor, twisted, stranded, unshielded. All wiring must comply with all applicable local and national codes.
- From the main indoor unit to the sub indoor unit(s), daisy chain using 22 AWG, 3-conductor, twisted, stranded, unshielded (**⊘ Do not** attach wire to 12VDC terminal to the sub indoor units). All wiring must comply with all applicable local and national codes.

Figure 50: Example of Indoor Unit Group to Zone Controller Connections (CN-REMO).

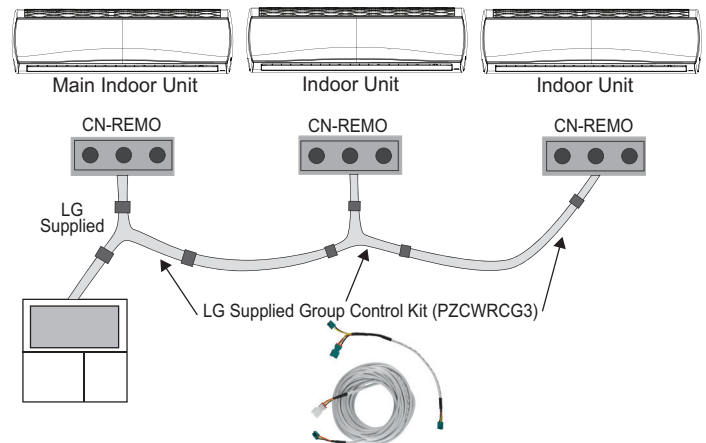

#### For indoor units with CN-REMO connections:

Use Group Control Kit (sold separately) containing extension and Y-splitter cables. Use one (1) group control cable kit for each indoor unit in the group except for the last indoor unit.

#### Note:

- Cable connected to zone controller is the factory default connection.
- Indoor unit connections depend on indoor unit type.

**Communication Cable Connection**

**Note:**

When connecting the communications bus between the outdoor unit, indoor unit(s), and heat recovery unit(s), it does not matter what physical path or route the wire takes. The installer may use discretion when choosing the order the components are connected to the communications bus, but must maintain the daisy chain and polarity configuration.

1. Remove a knock-out plug from the control box. Remember the communications cable and the power cable must enter the control box through different knockouts.
2. Field-install a plastic or rubber grommet in the knockout hole to prevent wire chaffing.
3. If using conduit, connect the conduit to the control box using field-provided fittings and industry best-practice procedures.
4. Provide at least three (3) to four (4) inches of slack cable at each indoor unit.
5. Secure the communications cable to the inside surface of the control box using a field provided nylon wire clamp.
6. Strip approximately quarter of an inch of insulation from each communications cable conductor. At each indoor unit, insert the conductors under the terminal screw.
7. Securely tighten the terminal screws to prevent the communications conductors from coming loose from the terminal block.
8. Secure the communications cable in appropriate locations outside the indoor unit to prevent damage to the cable or injury to maintenance personnel.

Figure 51: Location of Power Wiring and Communications Cable Terminals in the B8 High Static and L1, L2, and L3 Low Static Ducted Indoor Units

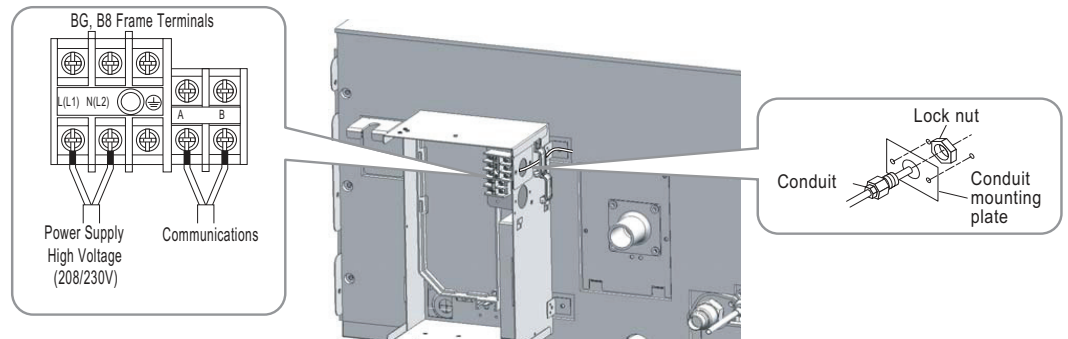
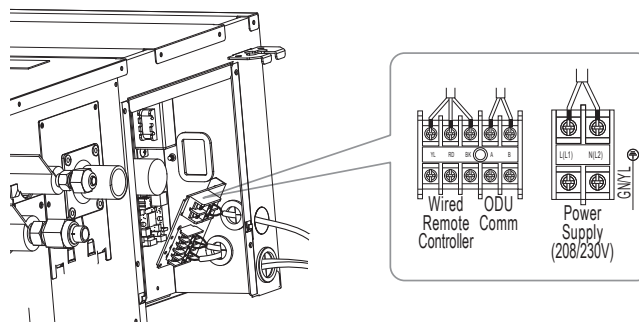

Figure 52: Location of Power Wiring and Communications Cable Terminals in the Mid Static (M1/M2/M3) and High Static (M2/M3) Ducted Indoor Units



## Indoor Unit Communication Cable Connections

Figure 53: Terminal Block in the Mid Static (M1/M2/M3) and High Static (M2/M3/B8) Ducted Indoor Units

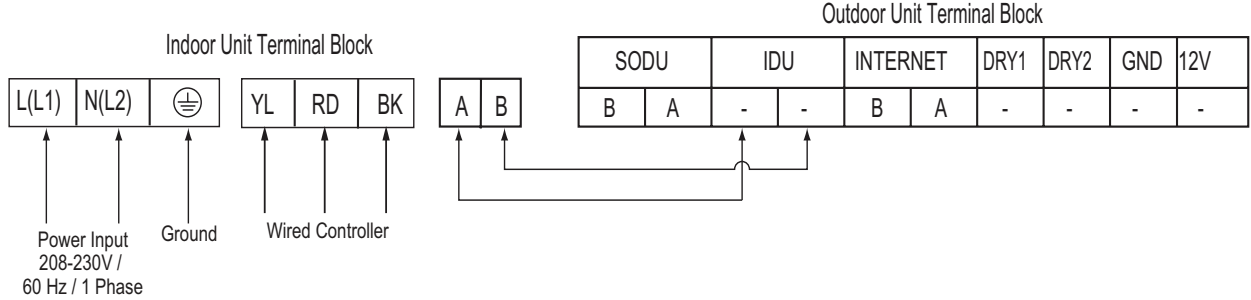

Figure 54: Terminal Block in the Low Static (L1, L2, L3 Chassis) Ducted Indoor Units

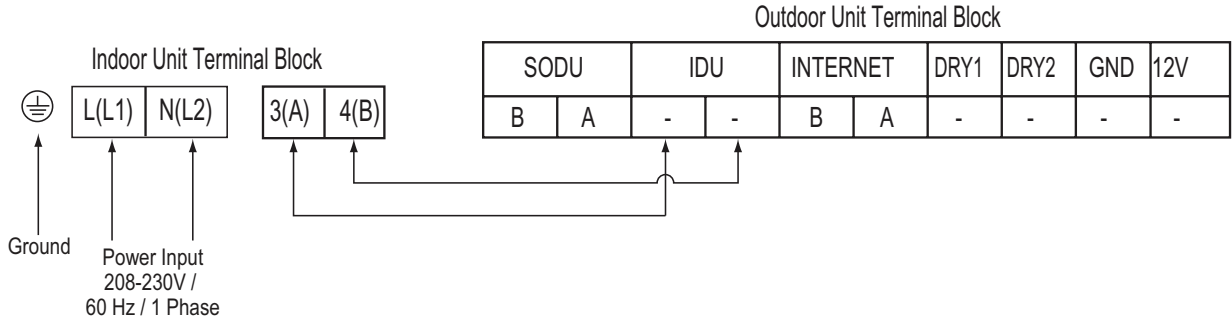

Figure 55: Location of Power Wiring and Communications Cable Terminals in the Vertical/Horizontal Air Handler Unit

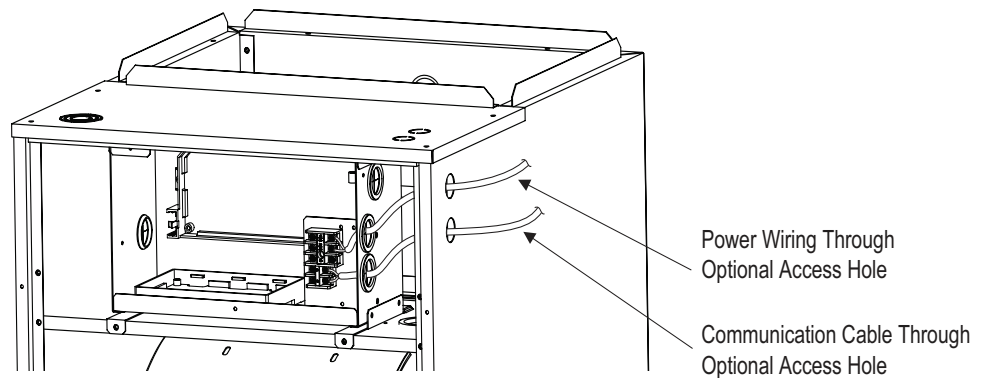
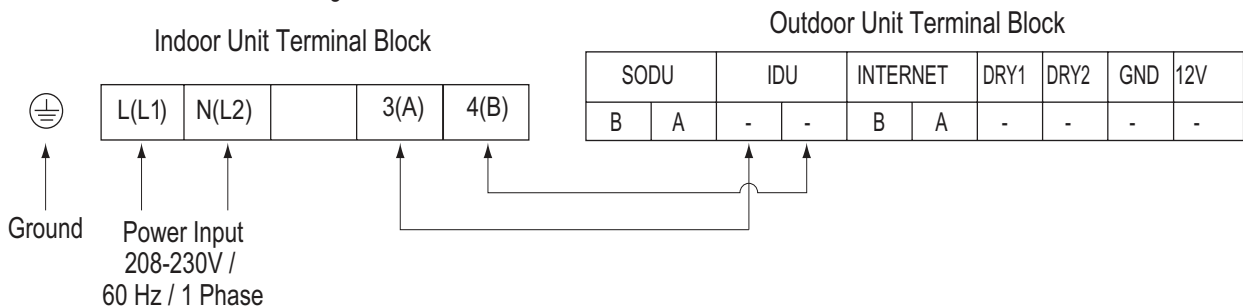

Figure 56: Terminal Block in the Vertical / Horizontal Air Handler Units



---

---

## Connecting the Power Wiring

### **⚠ DANGER**

High voltage electricity is required to operate this system. Adhere to the National Electrical Codes and these instructions when wiring. Always ground the unit following local, state, and National Electrical Codes. Read the safety summary at the beginning of this manual.

- Secure all field wiring connections with appropriate wire strain relief. Improperly securing wires will create undue stress on equipment power lugs. Inadequate connections will generate heat, cause a fire and physical injury or death.
- Properly tighten all power connections. Loose wiring will overheat at connection points, causing a fire, physical injury or death.

### **Note:**

- Connect the indoor unit input power cable but **⊘** do not apply power to the indoor unit until authorized to do so by the system commissioning agent. Inappropriate power connection can result in equipment damage and will void the LG limited liability warranty.
- When connecting the communications bus between the outdoor unit, indoor unit(s), and heat recovery unit(s), it does not matter what physical path or route the wire takes. The installer can use discretion when choosing the order the components are connected to the communications bus, but must maintain the daisy chain and polarity configuration.
- Failure to follow any of these power and communications wiring guidelines or instructions will cause communications errors and unit malfunction.

### **⊘ Don'ts**

- Never use wire caps and never splice communications cables.
- Never connect zone controllers or other central controllers or LG building management system gateways to the indoor unit / outdoor unit communications cable.

### **Connection Procedure**

Indoor unit installation best practices are to connect control wiring (low voltage) and then connect power wiring (high voltage). **⊘** Do not apply power to the indoor unit or any Multi V system component until authorized to do so by the system commissioning agent.

1. Ensure the input power is disconnected and there is no power on the power input cable.
2. Remove the knockout plugs from the control box. Remember the communications cable and the power cable must enter the control box through different knockouts.
3. Install a field provided plastic or rubber grommet in the knockout holes to prevent wire chaffing.
4. If using conduit, connect the conduit to the control box using field provided fittings and industry best-practice procedures.
5. Ensure the power wiring is routed separately from the communications cable to the unit's terminal block (see figures on the preceding pages). **⊘** Do not route the communications cable near the power cable. Provide at least three (3) to four (4) inches of slack cable at each indoor unit.

## Connection Procedure

---

---

### Note:

Power wiring is field supplied. Wire size is selected based on the larger MCA value, and must comply with the applicable local and national codes.

6. Connect the power wiring to the terminal block connections. Ensure the screws securely connect the wire to the terminals and are not loose.
7. Ensure the field-provided communications cable is connected to the 3(A) and 4(B) terminal block connections. Polarity matters on the outdoor unit to indoor unit / heat recovery unit communications bus, and must be maintained throughout the entire system. Be sure to connect 3(A) terminals to A terminals and 4(B) terminals to B terminals. Refer to the preceding pages for indoor unit wiring connections, the Outdoor Unit Installation Manual for information regarding the outdoor unit and heat recovery unit wiring connections, or review the wiring diagrams on the applicable units.

### Note:

- Cross connecting the 3(A) and 4(B) terminals will cause communications errors and system malfunction.
  - Field-provided communication cable between Main ODU to IDUs / HRUs to be 18 AWG, 2-conductor, twisted, stranded, shielded. Ensure the communication cable shield is properly grounded to the Main ODU chassis only. Shield must be tied together so it is continuous and insulated to prevent grounding against IDU/HRU electrical cabinet.  Do not ground the ODU to IDUs / HRUs communication cable at any other point. Wiring must comply with all applicable local and national codes.
8. If a remote controller is to be installed, connect the remote controller's cable to the indoor unit's remote controller connection. Controller connections depend on type of indoor unit being installed. Some indoor units use terminal block connections; other indoor units use Molex connections. See the wiring diagram for the specific indoor unit.



### LGRED° Technology

LGRED technology is included in Multi V 5 air-source units produced after February 2019. The feature allows heat pump or heat recovery systems to operate in heating only mode (i.e., all indoor units in heating mode) down to -22°F outdoor ambient wet bulb by updating the main PCB software (v1.26) and replacing an air temperature sensor. Multi V 5 air-source units without these changes can only operate down to -13°F. For more information, contact your local LG sales representative.

### PRHR\*3 Heat Recovery Units

The PRHR\*3A series of heat recovery units were released in June 2018, and are not automatically backwards compatible with all LG manufactured VRF air / water source units. The 3A heat recovery units will be compatible with many LG manufactured air source / water source units if its “Starting Production Date,” the “Production Starting Serial No.,” and / or the “Upgrade Software Service” dates fall after the dates shown below (see table).

LG VRF systems can operate with both old 2A heat recovery units and new 3A heat recovery units if the outdoor unit software has been upgraded. If a system includes a mix of both old and new heat recovery units, system design must follow 2A heat recovery unit series piping rules. For more information, contact your local LG sales representative.

Table 22: PRHR\*3 Heat Recovery Unit to Air / Water Source Unit Compatibility.

	Model	Starting Production Date	Production Starting Serial No.	Upgrade Software Service
<b>Multi V 5 with LGRED*</b>	ARUM****TE5	February 1, 2019	1902xxx	N/A
<b>Multi V 5</b>	ARUM****TE5	February 1, 2018	1802xxx	September 28, 2018
<b>Multi V S</b>	ARUB060GSS4	October 1, 2018	1810xxx	September 28, 2018
<b>Multi V Water IV</b>	ARWB****AS4	October 1, 2018	1810xxx	September 28, 2018
<b>Multi V IV</b>	ARUB****TE4	N/A	N/A	October 31, 2018
<b>Multi V II and III</b>	ARUB****TE2, ARUB****TE3	N/A	N/A	N/A
<b>Multi V Water II</b>	ARWB****A2	N/A	N/A	N/A

\*Low ambient performance with LGRED° heat technology is included in Multi V 5 air source units produced after February 2019.

### Generation 4 Indoor Units

LG’s indoor units are designated Generation 4 (Gen 4). For Gen 4 indoor units to operate with Gen 4 indoor unit features, the air conditioning system must meet the following requirements:

- All indoor units, heat recovery units, and air / water source units must be Gen 4 or higher. Gen 4 ODU and IDU model numbers end in “4.” HRU model numbers end in “02A” or “03A.”
- All air / water source units must have Gen 4 or higher software factory or field installed.
- Air / water source units DIP switch 3 must be set to ON (factory default setting is OFF).
- All controllers must support Gen 4 indoor unit features.

The figure at right shows the outdoor unit DIP switch. All air and water source units, indoor units, heat recovery units, and controllers in a system must be Gen 4 compatible or the system will not operate with Gen 4 indoor unit features.

If the ODU is powered On when dipswitch 3 is set to ON position, power must be cycled to the ODU or PCB reset for the setting to take effect.

Figure 57: Location and Setting of Outdoor Unit DIP Switch 3.

Air/Water Source Unit DIP Switch No. 3

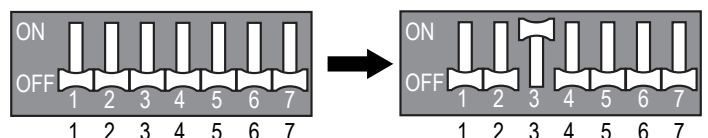
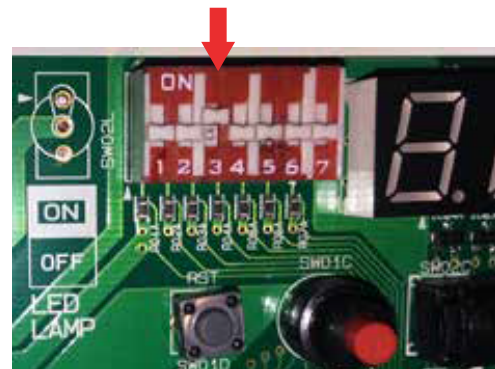

## Controller and Optional Wall-Mounted Sensor Installation

### Wired Controller Installation

Ceiling Cassette indoor units can be used with various wired controllers (optional; sold separately). Wired controllers include a sensor to detect room temperature. To maintain comfort levels in the conditioned space, the wired controller must be installed in a location away from direct sunlight, high humidity, and where it could be directly exposed to cold air. Controller must be installed four (4) to five (5) feet above the floor where its display can be read easily, in an area with good air circulation, and where it can detect an average room temperature.

⊘ Do not install the remote controller where it can be impacted by the following:

- Drafts or dead spots behind doors and in corners
- Hot or cold air from ducts
- Radiant heat from sun or appliances
- Concealed pipes and chimneys
- Uncontrolled areas such as an outside wall behind the remote controller

1. Pull communications cable between the controller handy box (if used) and the indoor unit (field supplied; see submittals for communication cable specifications).
2. Store a minimal amount of cable in the handy box. Any additional cable must be coiled and stored near the indoor unit control panel.
3. If the cable between a zone controller and the indoor unit is too long, ⊘ do not cut. Coil any spare communications cable, tie-wrap it, and leave it next to the indoor unit location.

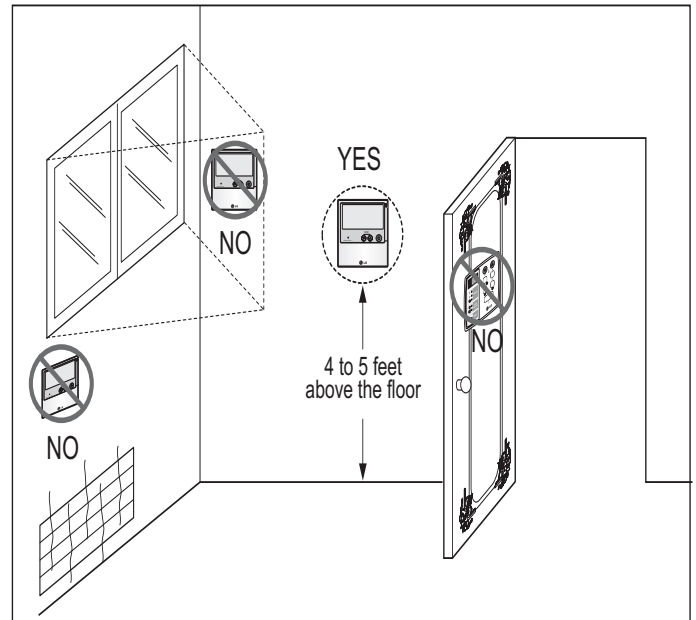

### Wall-Mounted Sensor Installation

Proper indoor unit operation depends on the location of the room sensor, if a room sensor is installed in addition to, or to use in place of a controller. A good location will protect the sensor from direct sunlight and external local sources of water vapor and air flow. If no mounting height was specified by the building designer, place the handy box approximately four (4) to five (5) feet above the finished floor.

- It may be necessary to use a handy box that is sized in metric units, depending on the sensor model. Check with your LG representative to verify which size of handy box is needed for the sensor in question.
- Maintain at least the minimum distance required between the communications cable and power wiring. The minimum required space between the two depends on the voltage of the power wiring.

### Note:

- ⊘ Do not route power wiring and communications cables in the same conduit. Routing power wiring and communications cables together will cause communication errors and unit malfunction.
- ⊘ Do not cut the quick-connect plugs off or adjust the length of the cable. Keep the communications cable away from high voltage wires and electromagnetic field (EMF) producing equipment. Performing these actions will cause communication errors and unit malfunction.

Optional Connections

Figure 58 shows the control board for the B8 chassis. Connect optional equipment to the control board as required for your system.

Figure 58: High-Static Ducted B8 Chassis Wiring Diagram

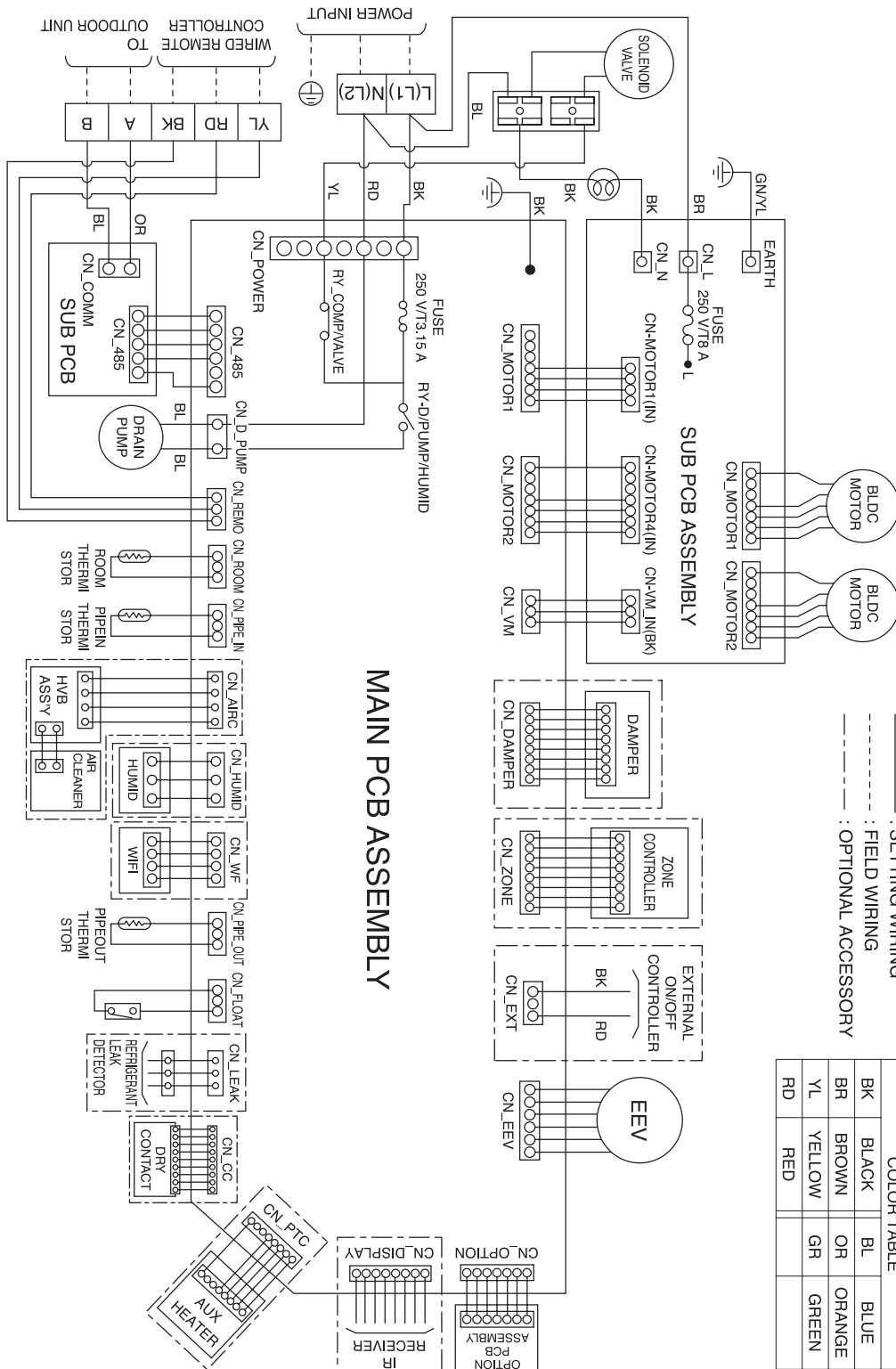

## High-Static Ducted B8 Chassis

Table 23: B8 Unit Wiring Diagram Legend.

Terminal	Purpose	Function
CN-POWER	AC Power supply	AC Power line
CN-MOTOR1	Fan motor output	Motor output of BLDC
CN-MOTOR2	Fan motor output	Motor output of BLDC
CN-VM	Sub PCB to Main PCB power supply	Power supply connection
CN-DAMPER	N / A	N / A
CN-ZONE	Zone controller	Zone controller connection
CN-EXT	External on / off controller	External on / off Controller connection
CN-EEV	EEV Output	EEV control output
CN-OPTION	Optional PCB EPROM	Option PCB connection
CN-DISPLAY	Display	Display of indoor status
CN-PTC	Auxiliary heater	Connection for Auxiliary Heater
CN-CC	Dry contact	Dry Contact connection
CN-LEAK	Leak detector	Leak detector connection
CN-FLOAT	Float switch input	Float switch sensing
CN-PIPE/OUT	Discharge pipe sensor	Pipe out thermistor
CN-WF	Wi-Fi	Wi-Fi module connection
CN-HUMID	N / A	N / A
CN-AIRC	N / A	N / A
CN-PIPE/IN	Suction pipe sensor	Pipe in thermistor
CN-ROOM	Room sensor	Room air thermistor
CN-REMO	Wired remote controller	Wired remote control connection
CN-D/PUMP	Drain pump output	AC output for drain pump
CN-485	Communication	Connection between indoor and outdoor units

Table 24: B8 Unit DIP Switch Settings.

DIP Switch Setting		Off	On	Remarks
SW3	GROUP CONTROL	Main	Sub	Group control setting using 7-Day Programmable Controller; selects Main / Sub on each indoor unit
SW4	DRY CONTACT MODE	Variable	Auto	Sets operation mode for optional Dry Contact accessory 1. Variable: Auto or Manual Mode can be set through 7-Day Programmable Controller or Wireless Remote Controller (factory default setting is Auto if there is no setting) 2. Auto: For Dry Contact, it is always Auto mode
SW5	CONTINUOUS FAN	Off	On	Selects continuous fan for ducted indoor units. 1. On: Indoor unit fan will always operate at a set fan speed, except when the system is off, or the outdoor unit is in defrost mode (when the outdoor unit is in defrost mode, the fan will operate at super low fan speed) 2. Off: Indoor unit fan speed can be changed by on / off

\*For Gen 4 Multi V ducted indoor units, DIP Switches 1, 2, 6 through 8 must be set to OFF. These DIP switches are used for other models.

\*\*To enable Generation 4 features, outdoor unit DIP Switch No. 3 must be set to ON. Please refer to the Multi V 5, Multi V Water IV, Multi V S Engineering Manuals for additional information.

Mid-Static and High-Static Ducted M2 Chassis

Optional Connections

Figure 59 shows the control board for the M2 chassis. Connect optional equipment to the control board as required for your system.

Figure 59: Mid-Static and High-Static Ducted M2 Chassis Wiring Diagram

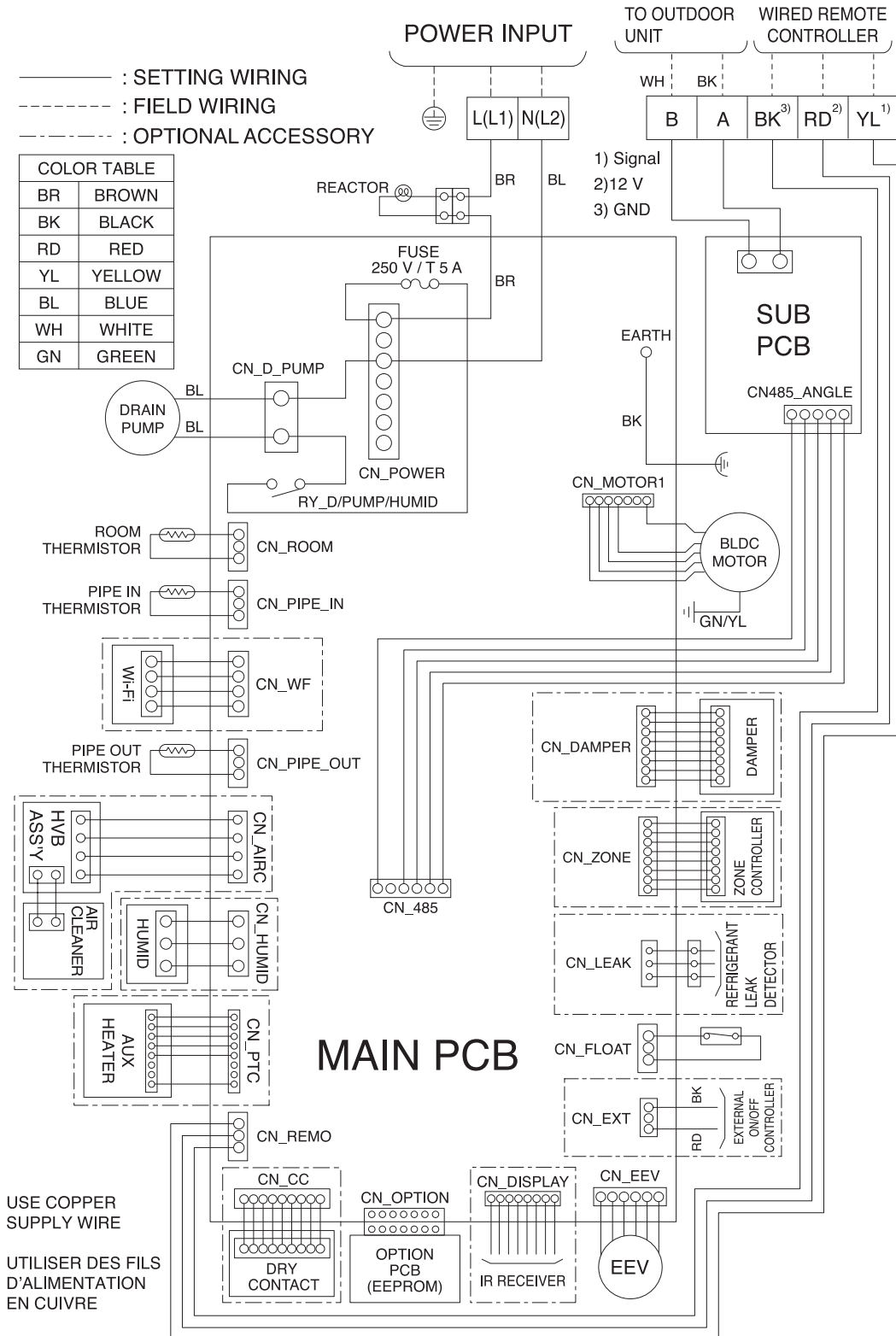

## Mid-Static and High-Static Ducted M2 Chassis

Table 25: M2 Unit Wiring Diagram Legend.

Terminal	Purpose	Function
CN-POWER	AC Power supply	AC Power line
CN-MOTOR1	Fan motor output	Motor output of BLDC
CN-VM	Sub PCB to Main PCB power supply	Power supply connection
CN-DAMPER	N / A	N / A
CN-ZONE	Zone controller	Zone controller connection
CN-EXT	External on / off controller	External on / off Controller connection
CN-EEV	EEV Output	EEV control output
CN-OPTION	Optional PCB EPROM	Option PCB connection
CN-DISPLAY	Display	Display of indoor status
CN-PTC	Auxiliary heater	Connection for Auxiliary Heater
CN-CC	Dry contact	Dry Contact connection
CN-HUMID	N / A	N / A
CN-LEAK	Leak detector	Leak detector connection
CN-FLOAT	Float switch input	Float switch sensing
CN-PIPE/OUT	Discharge pipe sensor	Pipe out thermistor
CN-WF	Wi-Fi	Wi-Fi module connection
CN-AIRC	N / A	N / A
CN-PIPE/IN	Suction pipe sensor	Pipe in thermistor
CN-ROOM	Room sensor	Room air thermistor
CN-REMO	Wired remote controller	Wired remote control connection
CN-D/PUMP	Drain pump output	AC output for drain pump
CN-485	Communication	Connection between indoor and outdoor units

Table 26: M2 Unit DIP Switch Settings.

DIP Switch Setting		Off	On	Remarks
SW3	GROUP CONTROL	Main	Sub	Group control setting using 7-Day Programmable Controller; selects Main / Sub on each indoor unit
SW4	DRY CONTACT MODE	Variable	Auto	Sets operation mode for optional Dry Contact accessory 1. Variable: Auto or Manual Mode can be set through 7-Day Programmable Controller or Wireless Remote Controller (factory default setting is Auto if there is no setting) 2. Auto: For Dry Contact, it is always Auto mode
SW5	CONTINUOUS FAN	Off	On	Selects continuous fan for ducted indoor units. 1. On: Indoor unit fan will always operate at a set fan speed, except when the system is off, or the outdoor unit is in defrost mode (when the outdoor unit is in defrost mode, the fan will operate at super low fan speed) 2. Off: Indoor unit fan speed can be changed by on / off

**\*For Gen 4 Multi V ducted indoor units, DIP Switches 1, 2, 6 through 8 must be set to OFF. These DIP switches are used for other models.**

**\*\*To enable Generation 4 features, outdoor unit DIP Switch No. 3 must be set to ON. Please refer to the Multi V 5, Multi V Water IV, Multi V S Engineering Manuals for additional information.**

Mid-Static and High-Static Ducted M3 Chassis

Optional Connections

Figure 60 shows the control board for the M3 chassis. Connect optional equipment to the control board as required for your system.

Figure 60: Mid-Static and High-Static Ducted M3 Chassis Wiring Diagram

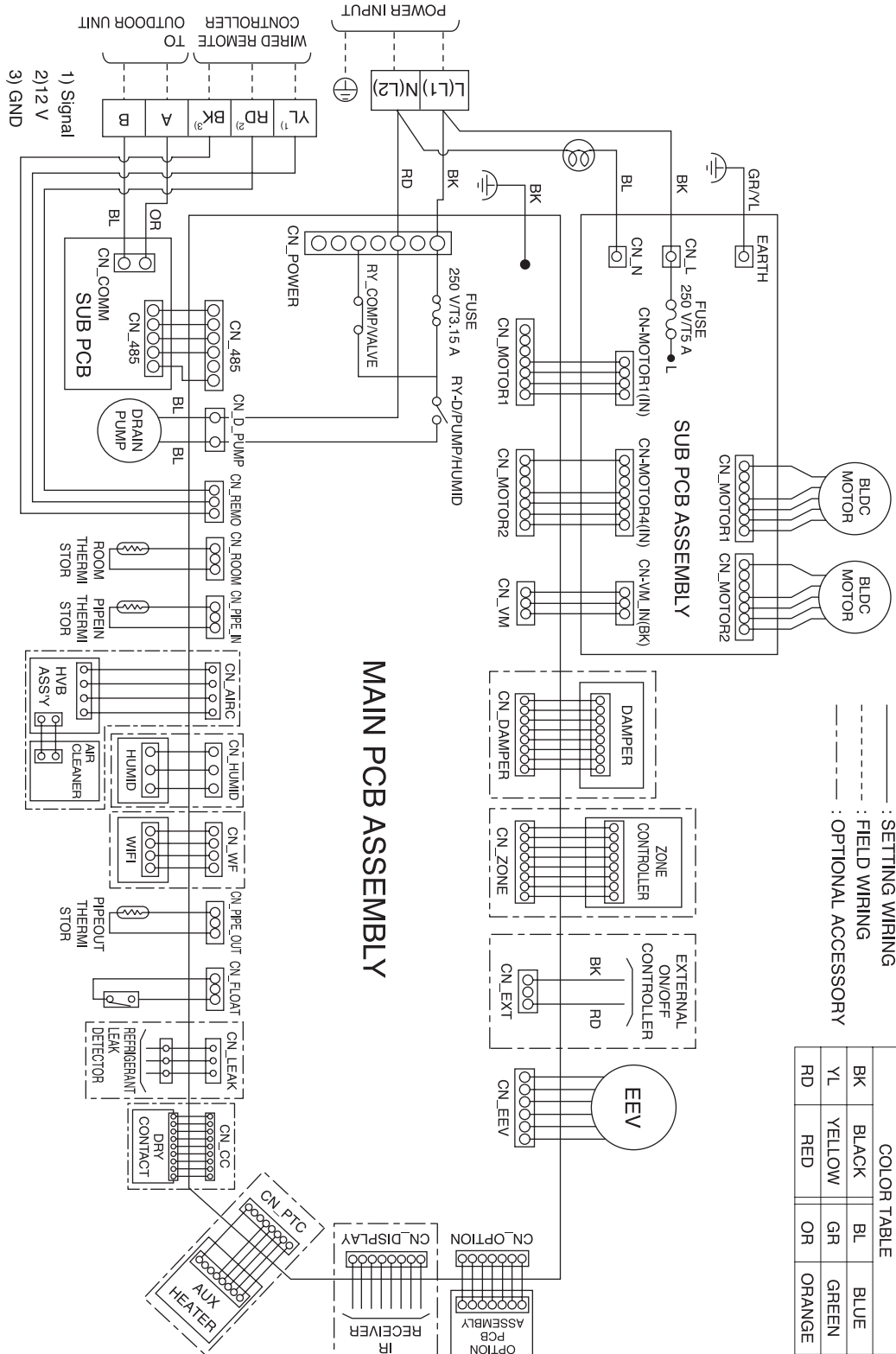

COLOR TABLE			
BK	BLACK	BL	BLUE
YL	YELLOW	GR	GREEN
RD	RED	OR	ORANGE

## Mid-Static and High-Static Ducted M3 Chassis

Table 27: M3 Unit Wiring Diagram Legend.

Terminal	Purpose	Function
CN-POWER	AC Power supply	AC Power line
CN-MOTOR1	Fan motor output	Motor output of BLDC
CN-MOTOR2	Fan motor output	Motor output of BLDC
CN-VM	Sub PCB to Main PCB power supply	Power supply connection
CN-DAMPER	N / A	N / A
CN-ZONE	Zone controller	Zone controller connection
CN-EXT	External on / off controller	External on / off Controller connection
CN-EEV	EEV Output	EEV control output
CN-OPTION	Optional PCB EPROM	Option PCB connection
CN-DISPLAY	Display	Display of indoor status
CN-PTC	Auxiliary heater	Connection for Auxiliary Heater
CN-CC	Dry contact	Dry Contact connection
CN-LEAK	Leak detector	Leak detector connection
CN-FLOAT	Float switch input	Float switch sensing
CN-PIPE/OUT	Discharge pipe sensor	Pipe out thermistor
CN-WF	Wi-Fi	Wi-Fi module connection
CN-HUMID	N / A	N / A
CN-AIRC	N / A	N / A
CN-PIPE/IN	Suction pipe sensor	Pipe in thermistor
CN-ROOM	Room sensor	Room air thermistor
CN-REMO	Wired remote controller	Wired remote control connection
CN-D/PUMP	Drain pump output	AC output for drain pump
CN-485	Communication	Connection between indoor and outdoor units

Table 28: M3 Unit DIP Switch Settings.

DIP Switch Setting		Off	On	Remarks
SW3	GROUP CONTROL	Main	Sub	Group control setting using 7-Day Programmable Controller; selects Main / Sub on each indoor unit
SW4	DRY CONTACT MODE	Variable	Auto	Sets operation mode for optional Dry Contact accessory 1. Variable: Auto or Manual Mode can be set through 7-Day Programmable Controller or Wireless Remote Controller (factory default setting is Auto if there is no setting) 2. Auto: For Dry Contact, it is always Auto mode
SW5	CONTINUOUS FAN	Off	On	Selects continuous fan for ducted indoor units. 1. On: Indoor unit fan will always operate at a set fan speed, except when the system is off, or the outdoor unit is in defrost mode (when the outdoor unit is in defrost mode, the fan will operate at super low fan speed) 2. Off: Indoor unit fan speed can be changed by on / off

**\*For Gen 4 Multi V ducted indoor units, DIP Switches 1, 2, 6 through 8 must be set to OFF. These DIP switches are used for other models.**

**\*\*To enable Generation 4 features, outdoor unit DIP Switch No. 3 must be set to ON. Please refer to the Multi V 5, Multi V Water IV, Multi V S Engineering Manuals for additional information.**





## Mid-Static Ducted M1 Chassis

Table 29: M1 Unit Wiring Diagram Legend.

Terminal	Purpose	Function
CN-POWER	AC Power supply	AC Power line
CN-MOTOR1	Fan motor output	Motor output of BLDC
CN-DAMPER	N / A	N / A
CN-ZONE	Zone controller	Zone controller connection
CN-EXT	External on / off controller	External on / off Controller connection
CN-EEV	EEV Output	EEV control output
CN-OPTION	Optional PCB EPROM	Option PCB connection
CN-DISPLAY	Display	Display of indoor status
CN-PTC	Auxiliary heater	Connection for Auxiliary Heater
CN-CC	Dry contact	Dry Contact connection
CN-HUMID	N / A	N / A
CN-LEAK	Leak detector	Leak detector connection
CN-FLOAT	Float switch input	Float switch sensing
CN-PIPE/OUT	Discharge pipe sensor	Pipe out thermistor
CN-WF	Wi-Fi	Wi-Fi module connection
CN-AIRC	N / A	N / A
CN-PIPE/IN	Suction pipe sensor	Pipe in thermistor
CN-ROOM	Room sensor	Room air thermistor
CN-REMO	Wired remote controller	Wired remote control connection
CN-D/PUMP	Drain pump output	AC output for drain pump
CN-485	Communication	Connection between indoor and outdoor units

Table 30: M1 Unit DIP Switch Settings.

DIP Switch Setting		Off	On	Remarks
SW3	GROUP CONTROL	Main	Sub	Group control setting using 7-Day Programmable Controller; selects Main / Sub on each indoor unit
SW4	DRY CONTACT MODE	Variable	Auto	Sets operation mode for optional Dry Contact accessory 1. Variable: Auto or Manual Mode can be set through 7-Day Programmable Controller or Wireless Remote Controller (factory default setting is Auto if there is no setting) 2. Auto: For Dry Contact, it is always Auto mode
SW5	CONTINUOUS FAN	Off	On	Selects continuous fan for ducted indoor units. 1. On: Indoor unit fan will always operate at a set fan speed, except when the system is off, or the outdoor unit is in defrost mode (when the outdoor unit is in defrost mode, the fan will operate at super low fan speed) 2. Off: Indoor unit fan speed can be changed by on / off

**\*For Gen 4 Multi V ducted indoor units, DIP Switches 1, 2, 6 through 8 must be set to OFF. These DIP switches are used for other models.**

**\*\*To enable Generation 4 features, outdoor unit DIP Switch No. 3 must be set to ON. Please refer to the Multi V 5, Multi V Water IV, Multi V S Engineering Manuals for additional information.**

Optional Connections

Figure 62 shows the control board for the L1 chassis. Connect optional equipment to the control board as required for your system.

Figure 62: Low-Static Ducted L1 Chassis Wiring Diagram

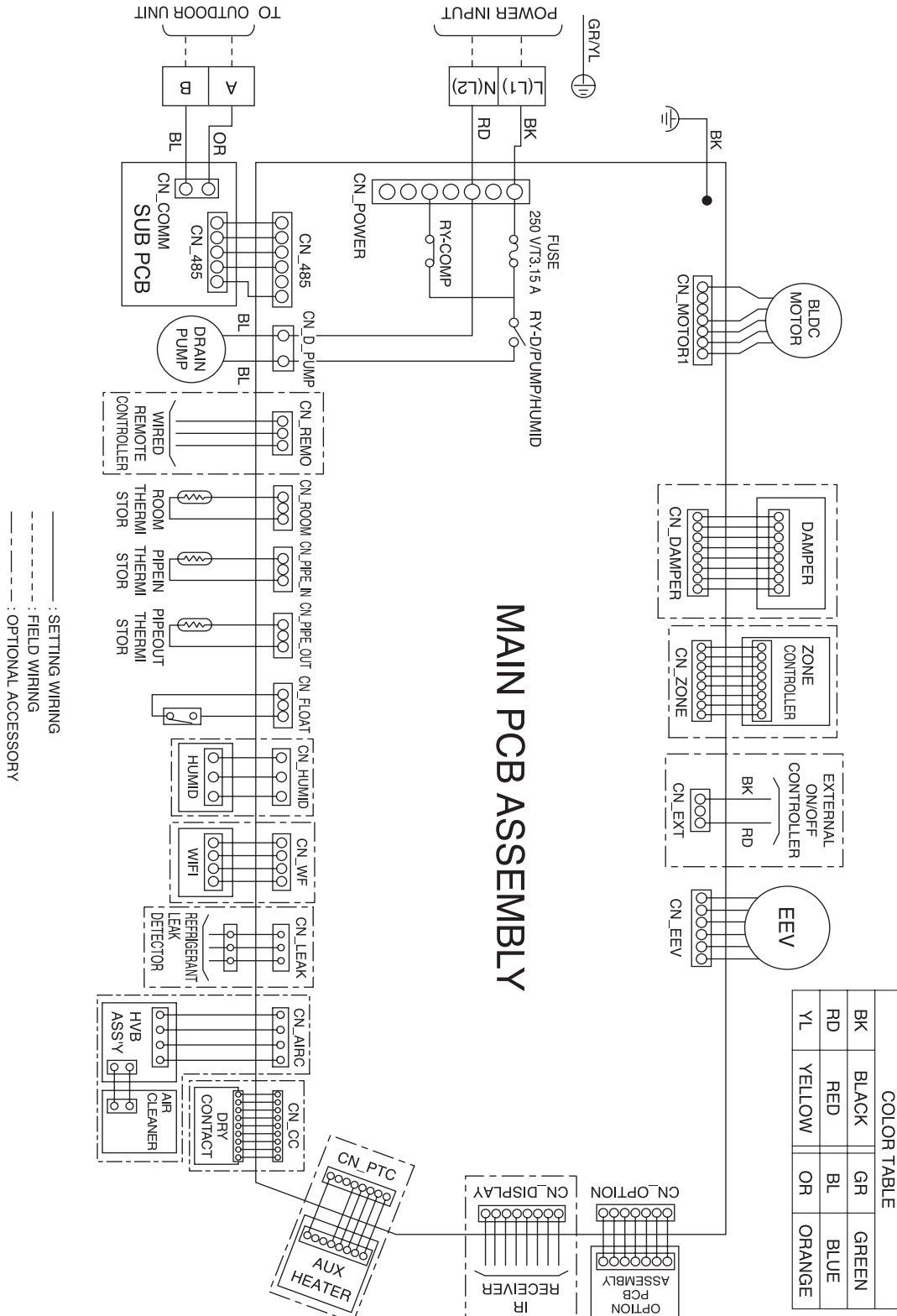

COLOR TABLE			
BK	BLACK	GR	GREEN
RD	RED	BL	BLUE
YL	YELLOW	OR	ORANGE

## Low-Static Ducted L1 Chassis

Table 31: L1 Unit Wiring Diagram Legend.

Terminal	Purpose	Function
CN-POWER	AC Power supply	AC Power line
CN-MOTOR1	Fan motor output	Motor output of BLDC
CN-DAMPER	N / A	N / A
CN-ZONE	Zone controller	Zone controller connection
CN-EXT	External on / off controller	External on / off Controller connection
CN-EEV	EEV Output	EEV control output
CN-OPTION	Optional PCB EPROM	Option PCB connection
CN-DISPLAY	Display	Display of indoor status
CN-PTC	Auxiliary heater	Connection for Auxiliary Heater
CN-CC	Dry contact	Dry Contact connection
CN-AIRC	N / A	N / A
CN-LEAK	Leak detector	Leak detector connection
CN-WF	Wi-Fi	Wi-Fi module connection
CN-HUMID	N / A	N / A
CN-FLOAT	Float switch input	Float switch sensing
CN-PIPE/OUT	Discharge pipe sensor	Pipe out thermistor
CN-PIPE/IN	Suction pipe sensor	Pipe in thermistor
CN-ROOM	Room sensor	Room air thermistor
CN-REMO	Wired remote controller	Wired remote control connection
CN-D/PUMP	Drain pump output	AC output for drain pump
CN-485	Communication	Connection between indoor and outdoor units

Table 32: L1 Unit DIP Switch Settings.

DIP Switch Setting		Off	On	Remarks
SW3	GROUP CONTROL	Main	Sub	Group control setting using 7-Day Programmable Controller; selects Main / Sub on each indoor unit
SW4	DRY CONTACT MODE	Variable	Auto	Sets operation mode for optional Dry Contact accessory 1. Variable: Auto or Manual Mode can be set through 7-Day Programmable Controller or Wireless Remote Controller (factory default setting is Auto if there is no setting) 2. Auto: For Dry Contact, it is always Auto mode
SW5	CONTINUOUS FAN	Off	On	Selects continuous fan for ducted indoor units. 1. On: Indoor unit fan will always operate at a set fan speed, except when the system is off, or the outdoor unit is in defrost mode (when the outdoor unit is in defrost mode, the fan will operate at super low fan speed) 2. Off: Indoor unit fan speed can be changed by on / off

**\*For Gen 4 Multi V ducted indoor units, DIP switches 1, 2, 6 through 8 must be set to OFF. These DIP switches are used for other models.**

**\*\*To enable Generation 4 features, outdoor unit DIP Switch No. 3 must be set to ON. Please refer to the Multi V 5, Multi V Water IV, Multi V S Engineering Manuals for additional information.**

**Optional Connections**

Figure 63 shows the control board for the L2/L3 chassis. Connect optional equipment to the control board as required for your system.

Figure 63: Low-Static Ducted L2/L3 Chassis Wiring Diagram

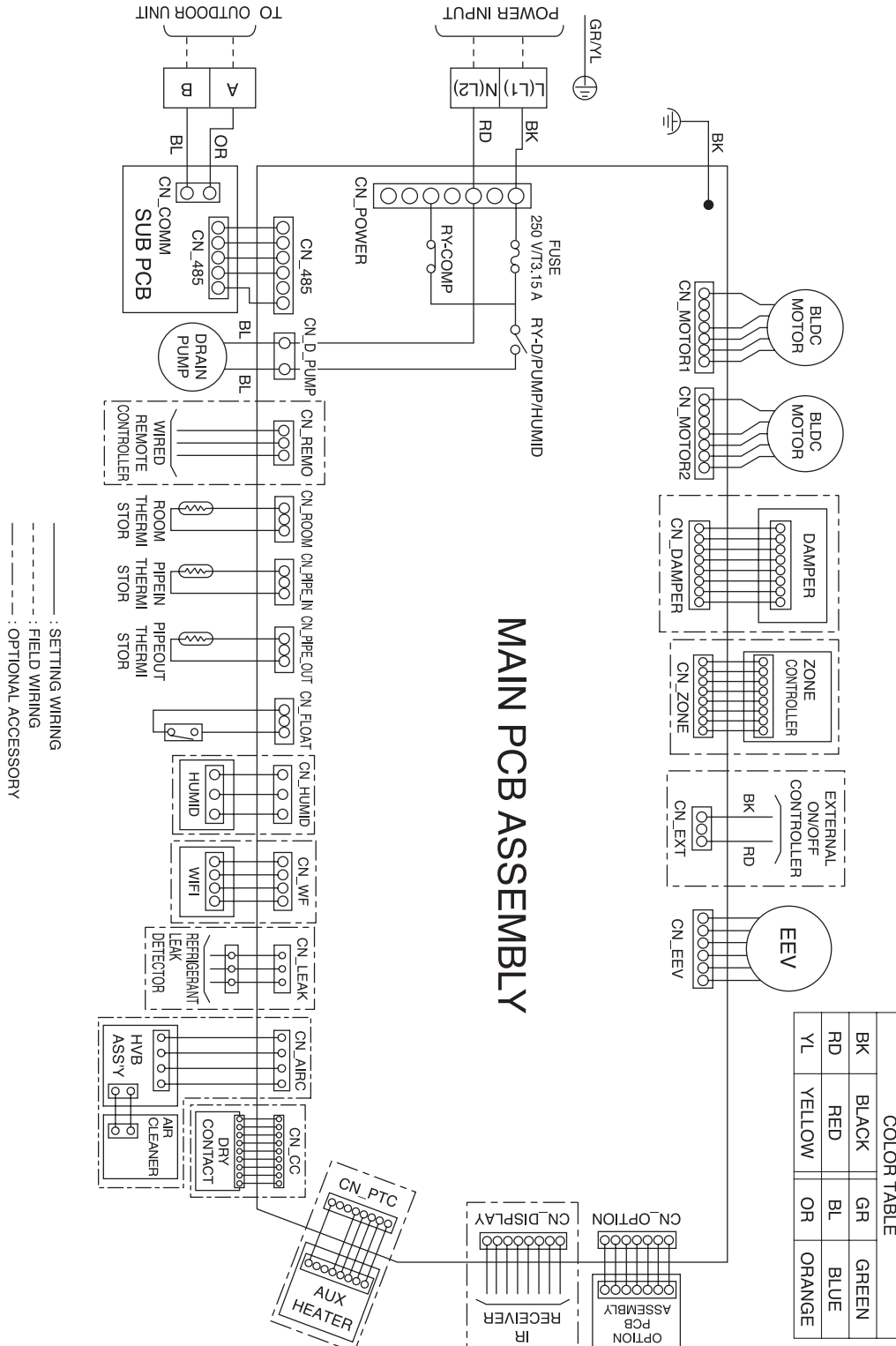

## Low-Static Ducted L2/L3 Chassis

Table 33: L2, L3 Unit Wiring Diagram Legend.

Terminal	Purpose	Function
CN-POWER	AC Power supply	AC Power line
CN-MOTOR1	Fan motor output	Motor output of BLDC
CN-MOTOR2	Fan motor output	Motor output of BLDC
CN-DAMPER	N / A	N / A
CN-ZONE	Zone controller	Zone controller connection
CN-EXT	External on / off controller	External on / off Controller connection
CN-EEV	EEV Output	EEV control output
CN-OPTION	Optional PCB EPROM	Option PCB connection
CN-DISPLAY	Display	Display of indoor status
CN-PTC	Auxiliary heater	Connection for Auxiliary Heater
CN-CC	Dry contact	Dry Contact connection
CN-AIRC	N / A	N / A
CN-LEAK	Leak detector	Leak detector connection
CN-WF	Wi-Fi	Wi-Fi module connection
CN-HUMID	N / A	N / A
CN-FLOAT	Float switch input	Float switch sensing
CN-PIPE/OUT	Discharge pipe sensor	Pipe out thermistor
CN-PIPE/IN	Suction pipe sensor	Pipe in thermistor
CN-ROOM	Room sensor	Room air thermistor
CN-REMO	Wired remote controller	Wired remote control connection
CN-D/PUMP	Drain pump output	AC output for drain pump
CN-485	Communication	Connection between indoor and outdoor units

Table 34: L2, L3 Unit DIP Switch Settings.

DIP Switch Setting		Off	On	Remarks
SW3	GROUP CONTROL	Main	Sub	Group control setting using 7-Day Programmable Controller; selects Main / Sub on each indoor unit
SW4	DRY CONTACT MODE	Variable	Auto	Sets operation mode for optional Dry Contact accessory 1. Variable: Auto or Manual Mode can be set through 7-Day Programmable Controller or Wireless Remote Controller (factory default setting is Auto if there is no setting) 2. Auto: For Dry Contact, it is always Auto mode
SW5	CONTINUOUS FAN	Off	On	Selects continuous fan for ducted indoor units. 1. On: Indoor unit fan will always operate at a set fan speed, except when the system is off, or the outdoor unit is in defrost mode (when the outdoor unit is in defrost mode, the fan will operate at super low fan speed) 2. Off: Indoor unit fan speed can be changed by on / off

**\*For Gen 4 Multi V ducted indoor units, DIP switches 1, 2, 6 through 8 must be set to OFF. These DIP switches are used for other models.**

**\*\*To enable Generation 4 features, outdoor unit DIP Switch No. 3 must be set to ON. Please refer to the Multi V 5, Multi V Water IV, Multi V S Engineering Manuals for additional information.**

Optional Connections

Figure 64 shows the control board for the NJ chassis. Connect optional equipment to the control board as required for your system.

Figure 64: Vertical Air Handler NJ Chassis Wiring Diagram

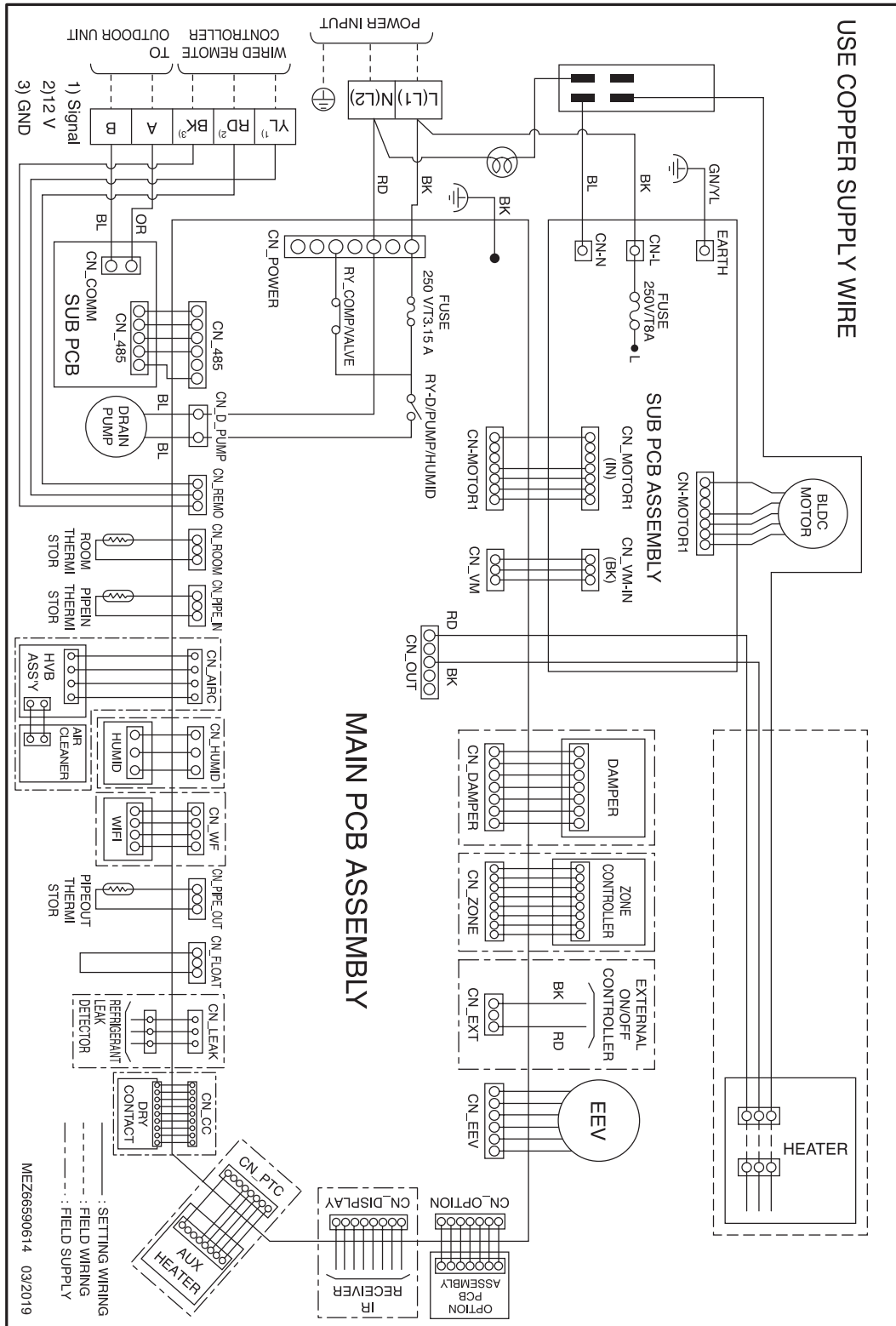

## Vertical Air Handler NJ Chassis

Table 35: NJ Frame Wiring Diagram Legend.

Terminal	Purpose	Function
CN-POWER	AC Power supply	AC Power line
CN-MOTOR1	Fan motor output	Motor output of BLDC
CN-VM	Sub PC power supply	Power supply connection
CN_OUT	Heater	Connection for heater
CN-DAMPER	N / A	N / A
CN-ZONE	Zone controller	Zone controller connection
CN-EXT	External ON / OFF controller	External ON / OFF controller connection
CN-EEV	EEV Output	EEV control output
CN-OPTION	Optional PCB EPROM	Option PCB connection
CN-DISPLAY	Display	Display of indoor status
CN-PTC	Auxiliary heater	Auxiliary heater connection
CN-CC	Dry contact	Dry Contact connection
CN-LEAK	Refrigerant leak detector	Refrigerant leak detector connection
CN-FLOAT	Float switch input	Float switch sensing
CN-PIPE-OUT	Discharge pipe sensor	Pipe out thermistor
CN-WF	Wi-Fi	Wi-Fi module connection
CN-HUMID	N / A	N / A
CN-AIRC	N / A	N / A
CN-PIPE-IN	Suction pipe sensor	Pipe in thermistor
CN-ROOM	Room sensor	Room air thermistor
CN-REMO	Wired remote controller	Wired remote control connection
CN-D-PUMP	Drain pump output	AC output for drain pump
CN-485	Communication	Connection between indoor and outdoor units

Table 36: NJ Frame DIP Switch Settings.

DIP Switch Setting		Off	On	Remarks
SW3	GROUP CONTROL	Main	Sub	Group control setting using 7-Day Programmable Controller; selects Main / Sub on each indoor unit
SW4	DRY CONTACT MODE	Variable	Auto	Sets operation mode for optional Dry Contact accessory 1. Variable: Auto or Manual Mode can be set through 7-Day Programmable Controller or Wireless Remote Controller (factory default setting is Auto if there is no setting) 2. Auto: For Dry Contact, it is always Auto mode
SW5	CONTINUOUS FAN	Off	On	Selects continuous fan for ducted indoor units. 1. On: Indoor unit fan will always operate at a set fan speed, except when the system is off, or the outdoor unit is in defrost mode (when the outdoor unit is in defrost mode, the fan will operate at super low fan speed) 2. Off: Indoor unit fan speed can be changed by on / off
SW6	HEATER INTERLOCK	Off	On	Selects heater interlock function for vertical air handler units 1. On: Automatic (heater will automatically operate during heating mode) 2. Off: Manual (heater needs to be manually turned on during heating mode)

**\*For Gen 4 Multi V vertical air handler indoor units, DIP switches 1, 2, 7 and 8 must be set to OFF. These DIP switches are used for other models.**

**\*\*To enable Generation 4 features, outdoor unit DIP Switch No. 3 must be set to ON. Please refer to the Multi V IV, Multi V Water IV, Multi V S Engineering Manuals for additional information.**



Optional Connections

Figure 65 shows the control board for the NK chassis. Connect optional equipment to the control board as required for your system.

Figure 65: Vertical Air Handler NK Chassis Wiring Diagram

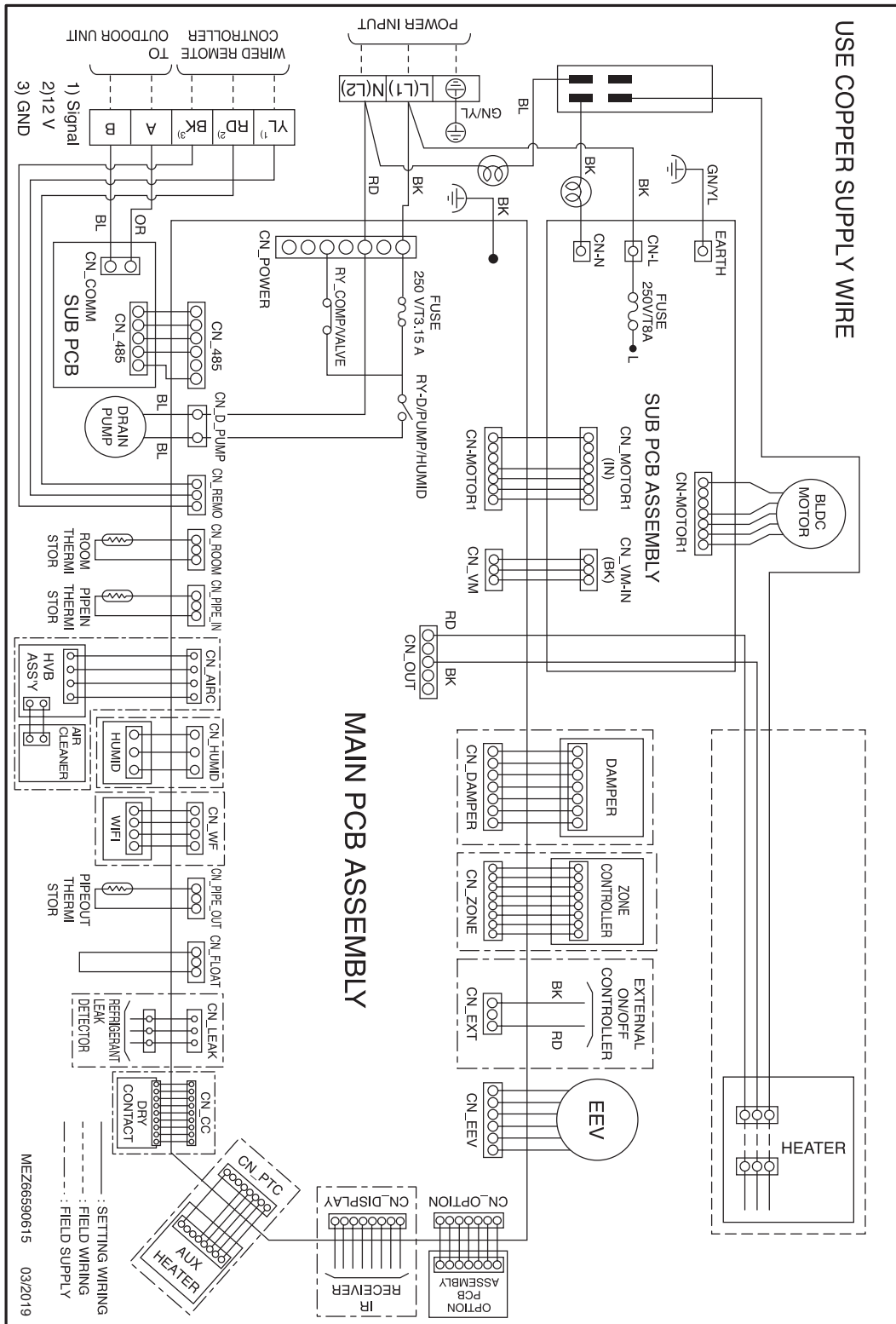

## Vertical Air Handler NK Chassis

Table 37: NK Frame Wiring Diagram Legend.

Terminal	Purpose	Function
CN-POWER	AC Power supply	AC Power line
CN-MOTOR1	Fan motor output	Motor output of BLDC
CN-VM	Sub PC power supply	Power supply connection
CN_OUT	Heater	Connection for heater
CN-DAMPER	N / A	N / A
CN-ZONE	Zone controller	Zone controller connection
CN-EXT	External ON / OFF controller	External ON / OFF controller connection
CN-EEV	EEV Output	EEV control output
CN-OPTION	Optional PCB EPROM	Option PCB connection
CN-DISPLAY	Display	Display of indoor status
CN-PTC	Auxiliary heater	Auxiliary heater connection
CN-CC	Dry contact	Dry Contact connection
CN-LEAK	Refrigerant leak detector	Refrigerant leak detector connection
CN-FLOAT	Float switch input	Float switch sensing
CN-PIPE-OUT	Discharge pipe sensor	Pipe out thermistor
CN-WF	Wi-Fi	Wi-Fi module connection
CN-HUMID	N / A	N / A
CN-AIRC	N / A	N / A
CN-PIPE-IN	Suction pipe sensor	Pipe in thermistor
CN-ROOM	Room sensor	Room air thermistor
CN-REMO	Wired remote controller	Wired remote control connection
CN-D-PUMP	Drain pump output	AC output for drain pump
CN-485	Communication	Connection between indoor and outdoor units

Table 38: NK Frame DIP Switch Settings.

DIP Switch Setting		Off	On	Remarks
SW3	GROUP CONTROL	Main	Sub	Group control setting using 7-Day Programmable Controller; selects Main / Sub on each indoor unit
SW4	DRY CONTACT MODE	Variable	Auto	Sets operation mode for optional Dry Contact accessory 1. Variable: Auto or Manual Mode can be set through 7-Day Programmable Controller or Wireless Remote Controller (factory default setting is Auto if there is no setting) 2. Auto: For Dry Contact, it is always Auto mode
SW5	CONTINUOUS FAN	Off	On	Selects continuous fan for ducted indoor units. 1. On: Indoor unit fan will always operate at a set fan speed, except when the system is off, or the outdoor unit is in defrost mode (when the outdoor unit is in defrost mode, the fan will operate at super low fan speed) 2. Off: Indoor unit fan speed can be changed by on / off
SW6	HEATER INTERLOCK	Off	On	Selects heater interlock function for vertical air handler units 1. On: Automatic (heater will automatically operate during heating mode) 2. Off: Manual (heater needs to be manually turned on during heating mode)

**\*For Gen 4 Multi V vertical air handler indoor units, DIP switches 1, 2, 7 and 8 must be set to OFF. These DIP switches are used for other models.**

**\*\*To enable Generation 4 features, outdoor unit DIP Switch No. 3 must be set to ON. Please refer to the Multi V IV, Multi V Water IV, Multi V S Engineering Manuals for additional information.**

## DIP Switch Settings

See the following pages for group control configurations. If the indoor unit is a main, set switch 3 of the indoor unit's DIP switch to Off. If the indoor unit is a sub, set switch 3 of the indoor unit's DIP switch to On. (See figures at right.) To ensure the remaining switches are set correctly, refer to the appropriate unit's DIP switch settings in the wiring section of this manual.

- Some indoor units do not have a DIP switch bank on the PCB. It is possible to set these units as main or sub with a wireless controller. Refer to the wireless controller manual for information.

Figure 66: Cassette Indoor Unit Main / Sub DIP Switch Settings.

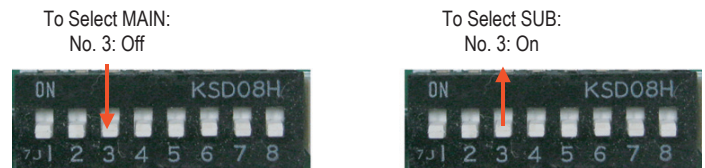

## Indoor Unit Control Configurations

The method and configuration of controlling indoor units will vary according to system requirements, and the indoor unit(s) installed. The next few pages show examples of typical control configurations. Some configurations require LG group control kits and cables (sold separately); contact your LG representative for information.

### Group Control - Method 1

- Controls up to 16 indoor units with one wired remote controller (group control). In group control, it is possible to use the following functions (depending on the indoor unit):
  - Operation selection, stop or mode
  - Temperature settings and room temperature check
  - Current time changes
  - Airflow rate (high, middle, low)
  - Reservation settings
- Set only one indoor unit in a group to main; set the others to sub. If main / sub(s) are not set properly in a group application, a malfunction will occur. See DIP Switch settings below.
- All types of indoor units can be configured in a Group Control - Method 1 configuration.
- A wireless remote controller can be used at the same time as a wired controller.
- A dry contact and central controller can be connected at the same time (to a main indoor unit only).
- A central controller can control all indoor units in a group by controlling the main unit of the group.
- ⓪ Sub indoor units cannot be individually controlled by the central controller.
- If an error occurs at an indoor unit, the error code is displayed at the wired remote controller. Indoor units not in error can still be controlled.
- Functions such as central control address, heating dead band, ESP settings, etc. must be set in the IDU before setting DIP switch 3 to ON and connecting the group control wire.

## Group Control - Method 1, continued.

Figure 67: Group Control - Method 1, One Wired Remote Controller Configured as a Main for Indoor Unit Group Control.

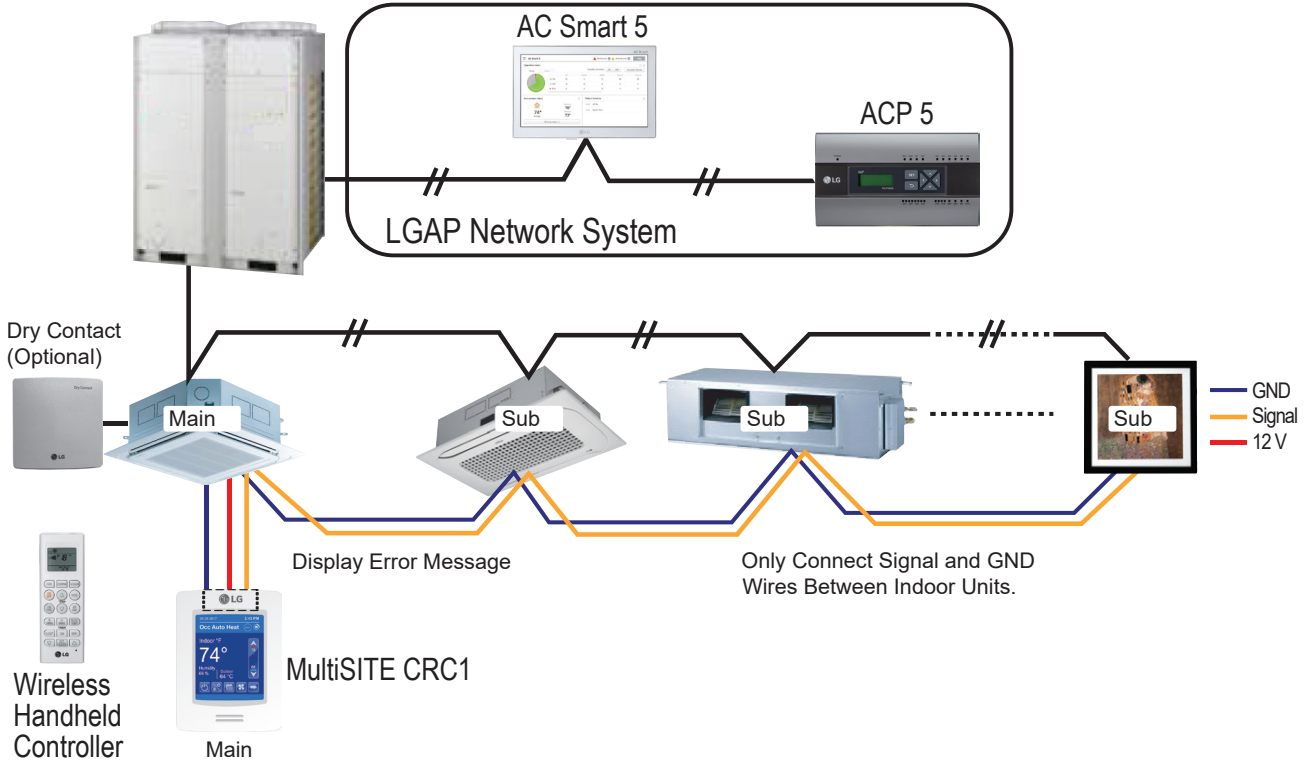

## Group Control - Method 2

Similar to Ground Control - Method 1, but controls up to 16 indoor units with the Main wired remote controller (group control).

Figure 68: Group Control - Method 2, Two Wired Remote Controllers; One Configured as a Main and the Other as a Sub.

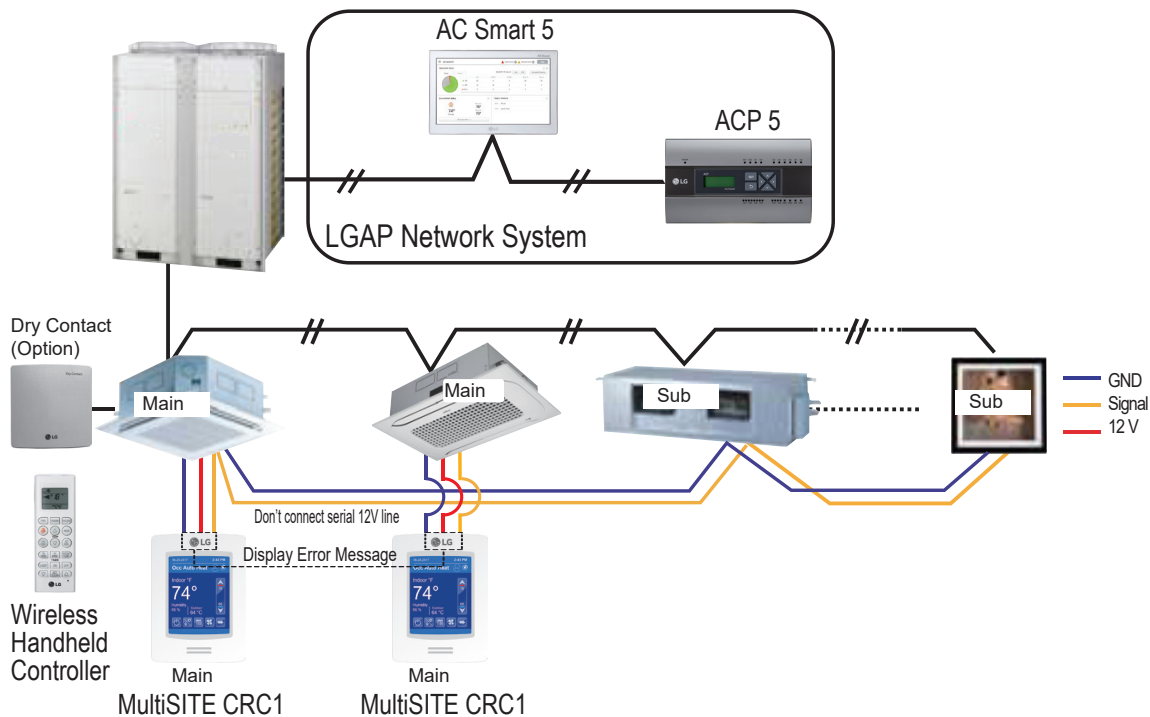

**Group Control - Method 3**

Similar to Group Control - Method 1, except outside air units and standard indoor units must be grouped separately (N, M ≤ 16) because set temperatures are different.

Figure 69: Group Control - Method 3, Standard Indoor Units and Outside Air Units Configured as Two Groups, Each with a Main Wired Controller.

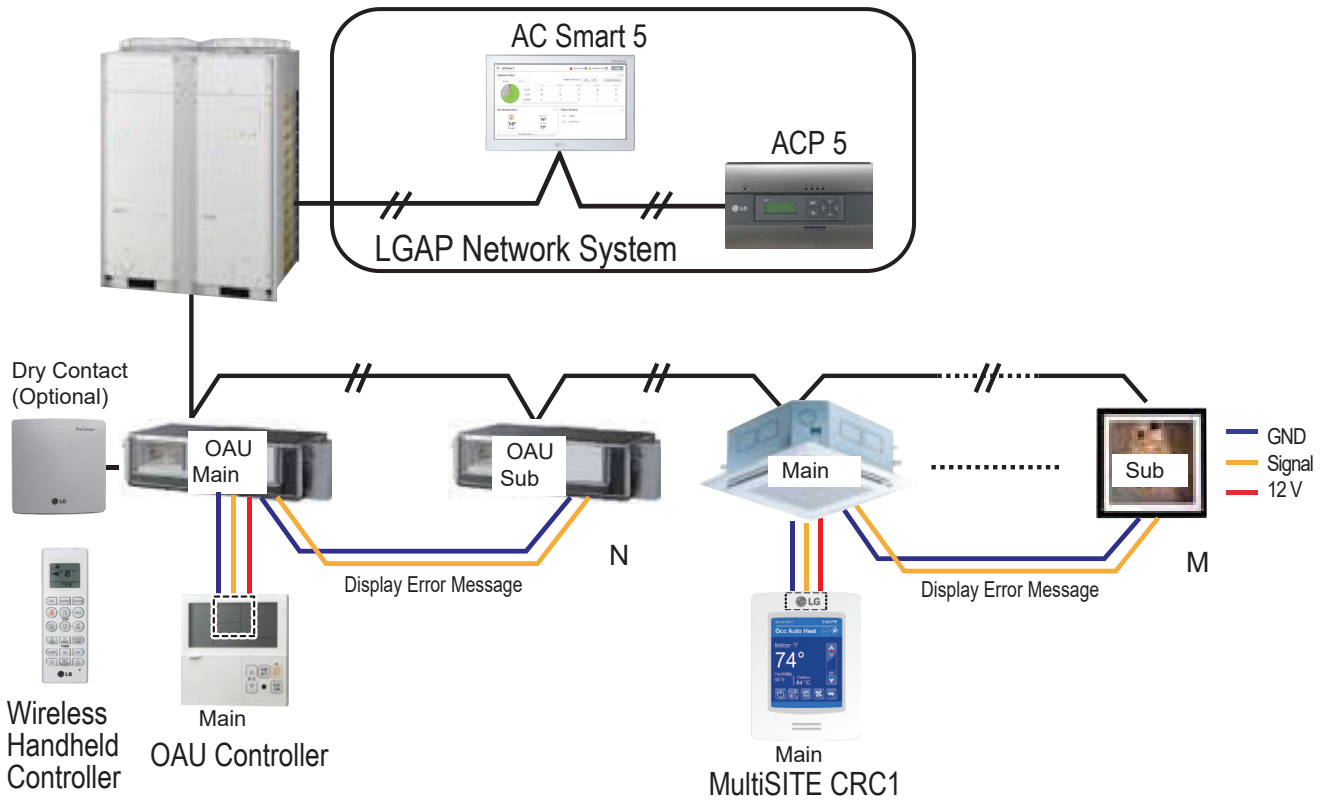
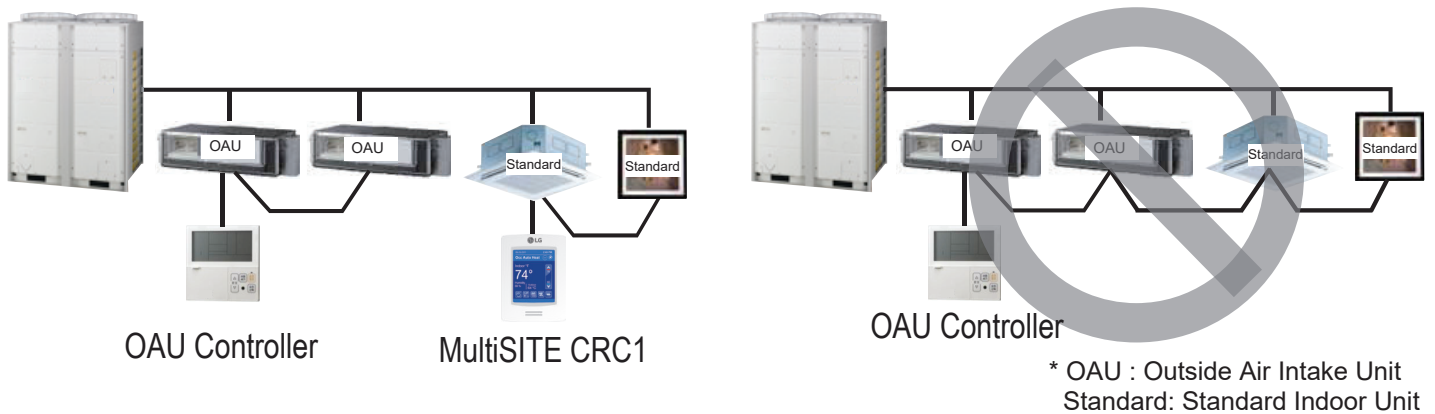

Figure 70: Correct and Incorrect Group Control Configuration with Standard Indoor Units and Outside Air Units.



## Group Control - Method 4

### Note:

The only remote controllers that support Group Control - Method 4 are the Simple Remote Controllers.

- Two Simple Remote Controllers (maximum) are connected to one indoor unit.
- Set only one indoor unit in a group to main; set the others to sub. If main / sub(s) are not set properly in a group application, a malfunction will occur.
- Set only one Simple Remote Controller to main; set the others to sub (IDU function 7).
- All types of indoor units can be configured in a Group Control - Method 4 configuration.
- A wireless remote controller can be used at the same time as a Simple Remote Controller.
- A dry contact and central controller can be connected at the same time (to a main indoor unit only).
- If an error occurs at an indoor unit, the error code is displayed at the Simple Remote Controller.
- Group Control - Method 4 supports all indoor unit functions.

Figure 71: Group Control - Method 4, Two Simple Remote Controllers Connected to One Indoor Unit.

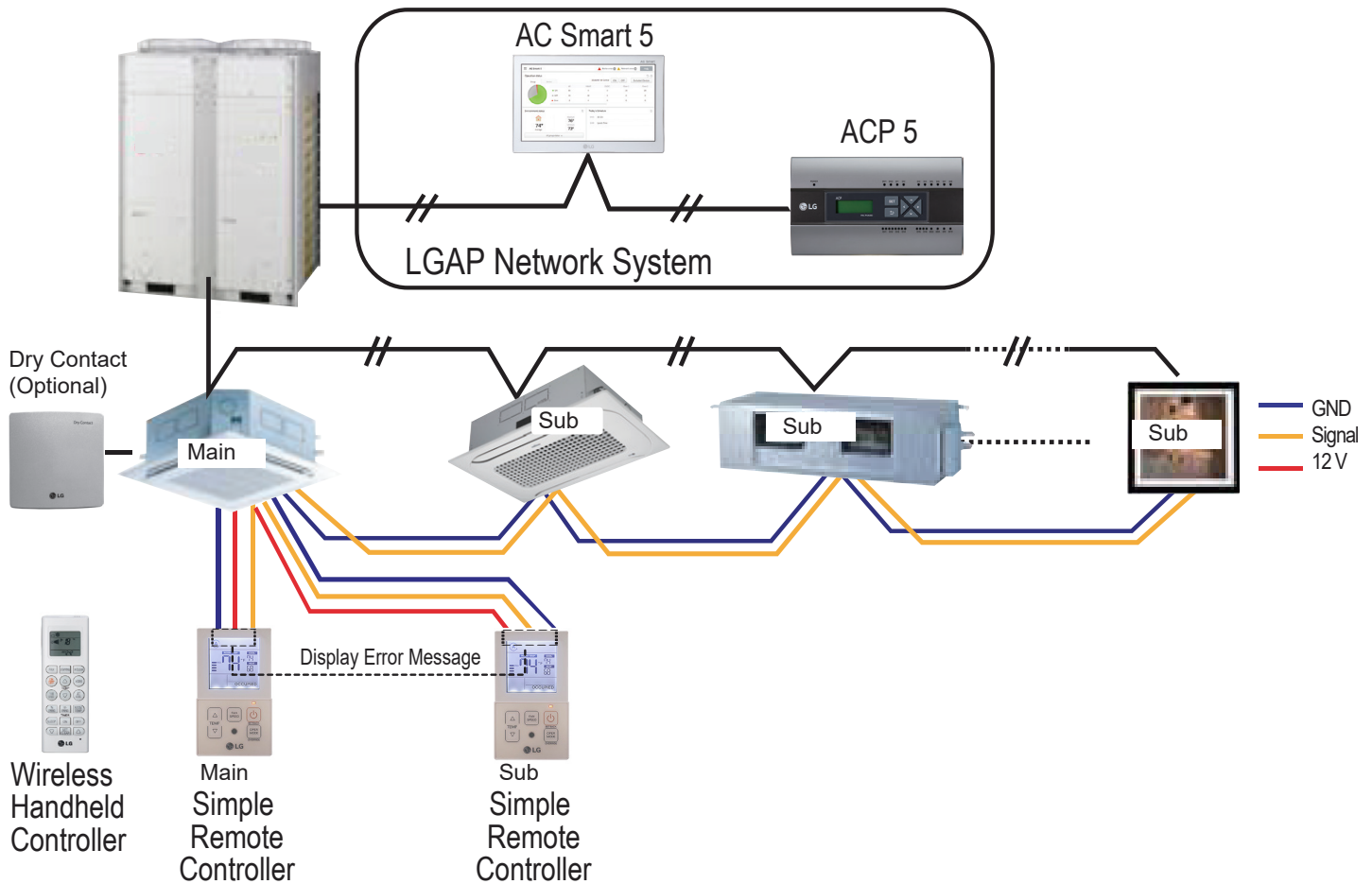

Multi V Ducted Indoor Units

**Remote Control**

Figure below shows an example of a remote control configuration.

Figure 72: Remote Control.

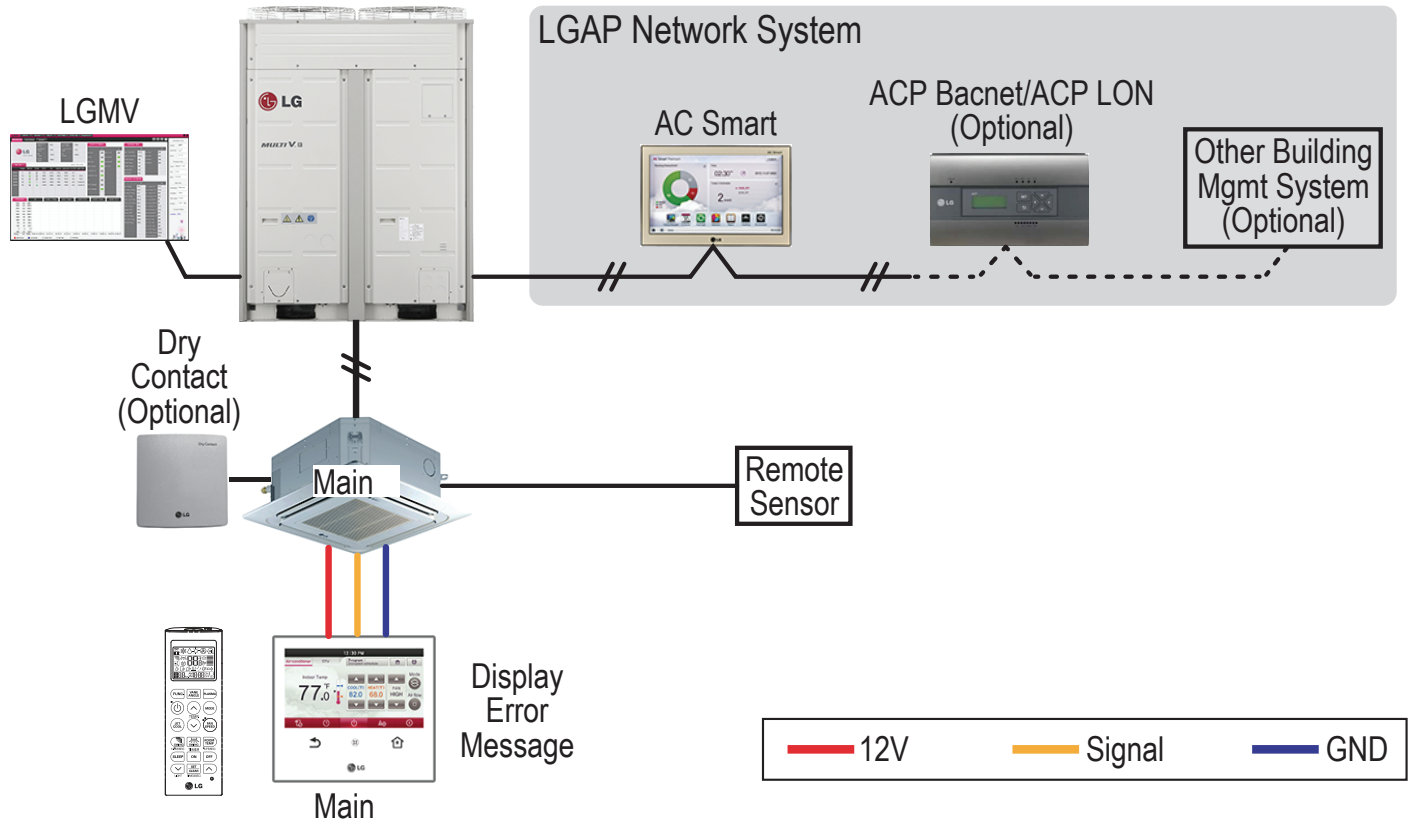

# INSTALLATION CHECKLIST



PAGE 1 of 2

System ID No.: \_\_\_\_\_ Indoor Unit ID.: \_\_\_\_\_

Checked by: \_\_\_\_\_ Date: \_\_\_\_\_ Signature: \_\_\_\_\_

4-Way Cassette Indoor Unit

<b>Rough-In</b>	<b>N/A</b>	<b>Not Complete</b>	<b>Complete</b>
Packing materials and literature removed from fan discharge.			
Airflow direction correct.			
Fan wheels spin without obstruction.			
Unit is properly supported – mounting bolts tight.			
Unit is level (condensate pump installations).			
Unit is canted toward gravity drain pan nipple (gravity drain installations only).			
Recommended minimum service clearances followed.			
Air filter is clean and properly installed.			
Does local code require a secondary drain pan under the indoor unit? Is a secondary drain line connected to the pan?			
<b>Ductwork</b>	<b>N/A</b>	<b>Not Complete</b>	<b>Complete</b>
All seams sealed – no air leaks.			
Mid and High-static models only – minimum external static pressure requirements met.			
Ductwork is properly sized considering the available external static pressure rating of the indoor unit fan.			
No kinks present in the flexible ductwork. Ductwork is properly supported.			
Ductwork balancing dampers have been installed and are correctly adjusted or open.			
Grilles and registers are properly sized and installed.			
<b>Refrigerant Piping</b>	<b>N/A</b>	<b>Not Complete</b>	<b>Complete</b>
A dry nitrogen purge rate of three (3) psig was maintained during all brazing activity.			
PVE refrigerant oil was used as a lubricant on flare fittings (POE type was NOT used).			
Field formed pipe flares are 45°.			
Flare fittings were properly tightened.			
Refrigerant pipe is properly supported to keep lateral pressure off unit connections.			
Refrigerant shutoff valves are full port design with integral Schrader port rated for R410A (option).			
Shutoff valves have the same internal pipe diameter as the connected pipe (option).			
Two shutoff valves were installed; one (1) high pressure liquid, one (1) low pressure vapor (option).			
Shutoff valves installed with Schrader port between the indoor unit and the ball of the valve (option).			
<b>Condensate System</b>	<b>N/A</b>	<b>Not Complete</b>	<b>Complete</b>
Condensate pipe is properly sized and supported to keep lateral pressure off unit connections.			
Condensate pipe horizontal segments are sloped a minimum of 1/4"/100' of pipe away from the indoor unit.			
Condensate pipe and drain traps were sized using LG recommendations.			
Field-provided condensate line check valve was installed in the condensate pipe riser (option).			
Condensate traps were installed on gravity drain pipes (Mid and High-Static models only).			
Condensate line vertical rise between indoor unit bottom and high point of the line does not exceed 27-1/2".			
Condensate pump power has been disconnected (Mid and High-Static indoor unit gravity-drain installations only).			
Condensate pump riser intersects the building main drain using an inverted trap with connection to the top half of the drain line with no more of a ±45° of vertical.			
If required by local code, is a secondary high level condensate shutoff switch present/wired properly (factory provided internal high level float switch will shut down cooling operation if high water level in the pan is detected)?			
<b>Insulation</b>	<b>N/A</b>	<b>Not Complete</b>	<b>Complete</b>
Additional housing, refrigerant and condensate pipe insulation has been supplemented to prevent sweating while operating if indoor unit installed in abnormal environmental conditions. (Optional - job condition specific.)			
All pipes are independently insulated. All insulation seams and joints are airtight. Insulation is not compressed. Double layer insulation is provided at pipe supports and wall penetrations.			





System ID No.: \_\_\_\_\_ Indoor Unit ID.: \_\_\_\_\_

Checked by: \_\_\_\_\_ Date: \_\_\_\_\_ Signature: \_\_\_\_\_

Electrical	N/A	Not Complete	Complete
Power provided is single phase, ±10% of indoor unit nameplate specifications.			
Power wires properly sized and protected per NEC and local codes. Indoor unit is properly grounded.			
Power and communications conductors are separated by the recommended minimum distance.			
Terminal block screws are tight. Power wires are not in contact with terminals 3(A) and / or 4(B). Line voltage wires have spade connectors installed.			
Power wires are properly secured to the control box case to prevent wire tension at the terminal block.			
Wires are protected from chaffing at control box and conduit pipe penetrations.			
(Optional) Smoke detector is properly installed and wired. New batteries are installed (if applicable).			
Low voltage control cables are properly secured to the control panel case. Terminal block screws are tight and the cable is protected from sharp edges at control box case and conduit openings.			
Cables are installed at recommended distances from high voltage and EMF generating equipment.			
Outdoor unit / Indoor unit communications cable (terminals 3[A] and 4[B]).			
Field provided communications cable is 18-2, twisted, stranded and shielded. All terminations are made at the terminal block. No inline splices or wire caps are present.			
Communications cable is plenum rated.			
Communications cable shield is tied back and is grounded at only ONE end.			
Wall Mounted Zone Controller Communications	N/A	Not Complete	Complete
LG factory provided zone controller stranded, shielded (white jacket) cable was used between the zone controller(s) and indoor unit(s). If field wiring is used, it must be 22AWG, 3 conductor, twisted, stranded, unshielded.			
Zone controller cable has not been cut, spliced, or tied together with wire caps. Factory plugs are present.			
Cable is securely plugged into the socket on the zone controller or the three screw terminals (controller model specific); Yellow to "Y", Red to "R", and Black to "B".			
Zone controller DIP switches have been adjusted for the application's space temperature sensing strategy.			
Indoor Unit Control Panel	N/A	Not Complete	Complete
Zone controller cable is securely plugged into the CN-REMO socket on the indoor unit circuit board.			
If an optional remote temperature sensor was installed, the associated cable is plugged into socket CN-ROOM (the factory return air thermistor has been unplugged).			
Indoor unit DIP switches have been adjusted for application (group control-main/sub; continuous fan operation; dry contact).			
If a gravity drain primary condensate system is used (condensate pipe ONLY connected to the lowest nipple) the CN-D / Pump plugged has been removed from the socket on the control board (High-Static models only).			
All plugs are properly seated in the sockets on the control board.			
Power and communications cables are properly restrained and separated.			

**Who to call for assistance**

Freight Damage and Unit Replacements	Your LG Manufacturer Representative
Missing Parts	Your LG Manufacturer Representative
Freight Damage and Unit Replacements	Your LG Manufacturer Representative
Received Wrong Indoor Unit Model	Your LG Manufacturer Representative
Installation, Startup, and Commissioning Technical Assistance	Your LG Manufacturer Representative

**For warranty information, visit [www.lghvac.com](http://www.lghvac.com).**

*Inverter*



20001747



ISO 9001:2008

LG ELECTRONICS INC.



LG Electronics, USA  
Air Conditioning Technologies  
4300 North Point Parkway  
Alpharetta, Georgia 30022  
[www.lghvac.com](http://www.lghvac.com)

IM\_MultiV\_Ducted\_IDU\_5\_21  
IM\_MultiV\_Ducted\_IDU\_10\_20  
Supersedes: IM\_MultiV\_Ducted\_IDU\_08\_20  
IM\_MultiV\_Ducted\_IDU\_05\_20  
IM\_MultiV\_Ducted\_IDU\_12\_19  
IM\_MultiV\_Ducted\_IDU\_5\_16  
IM-MultiV-DuctedIDU-08-14