

AM5000 - AM5000/3 - AM5000/5 ANAESTHESIA MODULE

SERVICE MANUAL

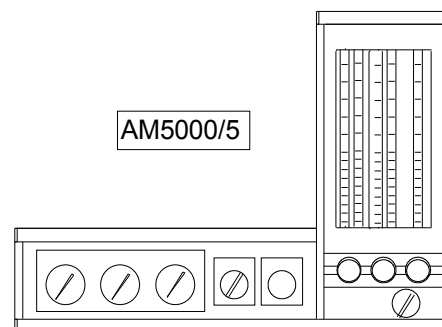
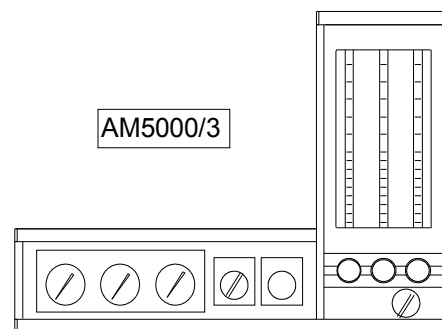
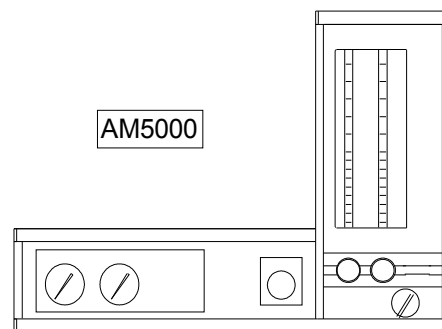

GENERAL INDEX

1. USE OF SERVICE MANUAL.....	3
1.1 Users of Manual.....	3
1.2 Description of use.....	3
1.3 Safety Notes.....	3
2. MAINTENANCE PROCEDURES.....	5
2.1 General Information.....	5
3. TECHNICAL DESCRIPTION.....	6
3.1 AM5000 AM5000/3 - AM5000/5 anaesthesia module.....	6
3.2 The Pneumatic Distributor.....	8
4. CALIBRATION AND TESTING.....	13
4.1 Flowmeter Box.....	13
4.2 Final Test.....	24
5. PNEUMATICS.....	29
5.1 Pneumatic Diagram AM5000.....	29
5.2 Components List FOR AM 5000/.....	30
5.3 Pneumatic Diagram AM5000/3.....	31
5.4 Components List FOR AM 5000/3.....	32
5.5 Pneumatic Diagram AM5000/5.....	33
5.6 Components List FOR AM 5000/5.....	34

Warning

SIARE is used throughout this manual as an abbreviation for

SIARE HOSPITAL SUPPLIES S.r.l.
Via Giulio Pastore, 18 - 40056 Crespellano (BO) - ITALY
Tel.: +39- 051/969802
Fax: +39-051/969101

Manufacturer of the equipment described in this manual

1. USE OF SERVICE MANUAL

1.1 Users of Manual

This manual is strictly for use by SIARE technicians or qualified technicians authorized by SIARE: The technician authorized by SIARE has available the appropriate tools and spare parts and is trained with regards to the safety of the product.

SIARE declines all responsibility with regards to technical assistance to the unit without formal authorization of SIARE.

The correct and safe use for the patient and the operator of the unit, requires the knowledge of the instructions and advice written in this manual and the User's manual.

1.2 Description of use

The symbol  placed near an instruction, calls the reader's attention to important information regarding the safety of the patient and operator.

The manual describes the unit and its operation with the help of electrical and pneumatic diagrams. The User's manual is an integral part of this manual, and the technician should have available a copy of the User's manual and should know its contents before performing any of the operations described in this manual.

1.3 Safety Notes

WARNINGS

The unit has been designed and is manufactured in conditions that guarantee the quality of the product and its components, in order to ensure the maximum level of reliability and the safety of the patient and the operator.

Therefore its safety is guaranteed only if it is used as per the instructions contained in this manual and the User's manual which is an integral and unseparable part of the product documentation for the technical assistance.

For safety reasons, it is necessary to strictly follow the scheduled maintenance described in the User's manual.

The maintenance and the replacement of any parts has to be performed by authorized SIARE service dealers and only original SIARE parts or parts checked by SIARE should be used.

SIARE is not civically or criminally liable in the following cases:

- 1) Use in conditions and for reasons not stated or prescribed in this manual.
- 2) Lack or omission of scheduled maintenance as described in this manual.
- 3) Maintenance performed by personnel not authorized by SIARE.
- 4) Use of non original spare parts or spare parts not checked and approved by SIARE.
- 5) Connection with equipment that is not in compliance with relevant directives in effect.



Do not use the equipment in the presence of flammable gases.

In order to avoid risk of explosion this unit should not be used in the presence of flammable anaesthetic gases such as ether or cyclopropane. This unit can operate only with anesthetics that are not flammable as per the directive relative to the electrical safety of the anaesthesia units.



Do not connect the unit to the patient using conductive antistatic tubes.

Due to the fact that this machine cannot be used with flammable anaesthetic agents, such as ether or cyclopropane, the use of antistatic patient tubes is not necessary. Since the use of antistatic tubes can cause burns when using surgical equipment at high frequencies, their use is not allowed in any administration with this equipment.



The unit is not approved for use in areas with danger of explosion.

The unit cannot be used in the presence of explosive gases.

Before connecting the unit with other electrical equipment not described in this manual, check with the manufacturer.

Regarding electro-medical equipment's general safety, it is important to follow all rules regarding the interaction between the equipment and the patient, the operator and the nearby environment.

In order to ensure proper and safe use of the equipment it is crucial to follow the instructions in this manual and the User's manual and pay attention to the notes furnished in this User's manual. In order to use this equipment, it is vital to know all the instructions in this manual.

The equipment should be inspected and the maintenance performed by SIARE authorized personnel every 6 (six) months. All maintenance performed by SIARE authorized personnel is recorded in the equipment's maintenance log.

Every repair should be performed by SIARE authorized personnel. Siare is not liable for direct or indirect damage to people or things, due to technical assistance by personnel non-authorized by SIARE or improper use of the equipment, that is to say a use not described in the User's manual or technical manual.

In order to repair equipment that is malfunctioning, has defects or is broken, the operator should contact SIARE or its authorized local service dealer. It is important, when requesting service, to specify the model and serial number of the equipment.

Use only the recommended accessories.

The use of other accessories is authorized only by a written authorization from SIARE as per the safety directives in effect.

The equipment's operation is authorized only in areas that conform to the safety directives in effect.

2. MAINTENANCE PROCEDURES

2.1 General Information



In order to ensure the safety of the patient and the operator, the unit should undergo an inspection and test after 800 hours of use or every 6 months, whichever comes first. The inspection and test require a specific knowledge of the unit, and therefore have to be made by specially trained SIARE authorized personnel.

The anesthetist or doctor is responsible for the ordinary maintenance of the unit, as described in this chapter. Cleaning, disinfecting, sterilization and replacement of parts should be done as per the instructions in the user's manual in order to avoid damage to the equipment that could also endanger the safety of the patient and operator.

The components used have been selected after technical and comparative tests in the designing phase of the machine.

Furthermore, the same components are always tested during the manufacturing cycle in order to obtain the maximum level of safety and reliability for the operator and patient.

Therefore whenever a part needs to be replaced, it must be an original spare part, which has been checked and tested by SIARE.

SIARE assumes responsibility for all provisions of the law, if the unit is used and maintained as per the instructions in this manual and the technical manual. The Technical Assistance Report, signed by the authorized SIARE technician, is proof of the completion of the scheduled maintenance.

3. TECHNICAL DESCRIPTION

3.1 AM5000 AM5000/3 - AM5000/5 anaesthesia module

AM5000 - AM5000/3 – AM5000/5 regulates the supply and concentration of the gas mixture (Air, O₂, N₂O), and also supplies it to the anaesthetic gas vaporizer.

It also allows the selection of the gas mixture to be supplied (Air-O₂, or N₂O-O₂) and the enrichment (with oxygen) of the supplied gas mixture for emergencies. The AM5000 - AM5000/3 – AM5000/5 is also equipped with the MIX-LIFE device that guarantees a minimum of 25% oxygen in all open-tap conditions.

By using the three gauges located on the front panel, the medical gases supply pressure coming from the central gas installation can be continuously controlled (precision $\pm 10\%$).

The flowmeters permit the measurement of the flow of the corresponding gases with a precision of $\pm 10\%$ of the displayed value or $\pm 1\%$ of the bottom of the scale, by choosing the highest of the two values.

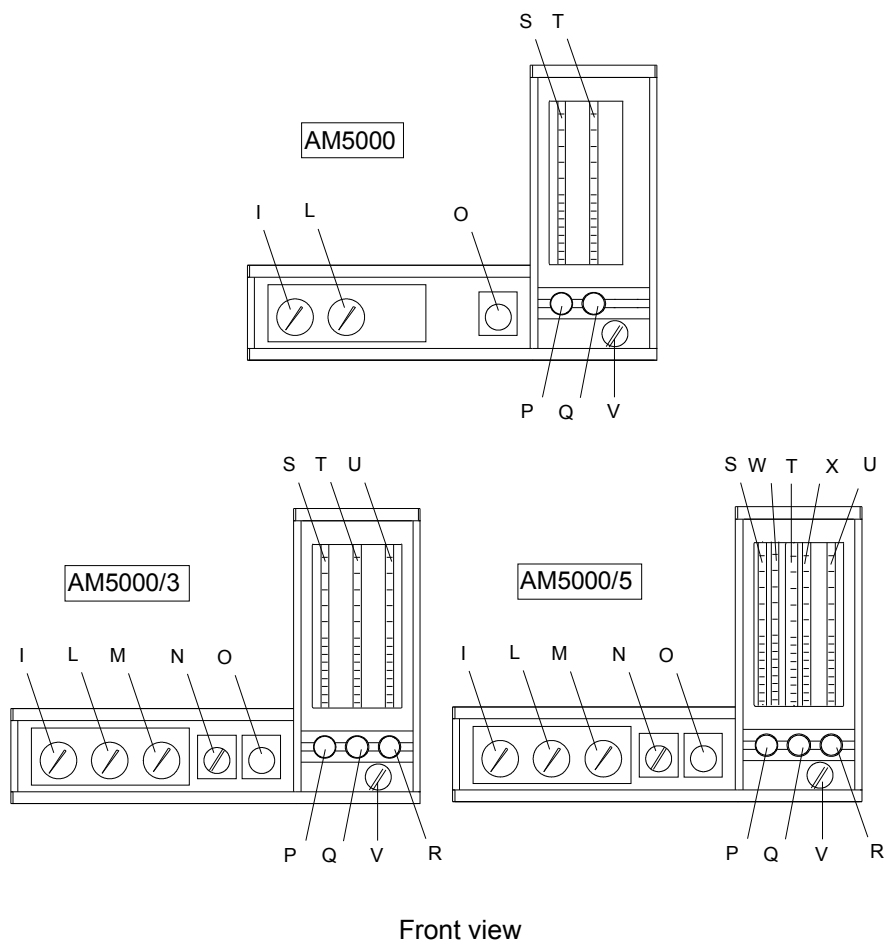

Front view

- I OXYGEN supply gauge.
- L NITROUS OXIDE supply gauge.
- M AIR supply gauge.
- N Selector switch for AIR / NITROUS OXIDE. This safety device: avoids the contemporaneous supply of air and nitrous oxide only the selected gas will be available on the flowmeters.
- O OXYGEN BY-PASS key. By pressing this key pure oxygen is released into the anaesthesia circuit with a flow of approximately 60 l/min.
- P OXYGEN flow regulator for fresh gases. It opens counter-clockwise.
- Q NITROUS OXIDE flow regulator for fresh gases. It opens counter-clockwise.

The opening of this regulator automatically supplies a flow of oxygen of about 25% of the total mixture. The flow of oxygen can be viewed on flowmeter (S). This safety device (MIX LIFE) avoid the incorrect administration of hypoxic mixtures.

- R AIR flow regulator for fresh gases. It opens counter-clockwise.
- S OXYGEN flowmeter (Max flow 12 l/min). In the model for low flows, there is a second flowmeter (W) with a lower scale of 1 liter.
- T NITROUS OXIDE flowmeter (Max flow 12 l/min).. In the model for low flows, there is a second flowmeter (X) with a lower scale of 1 liter.
- U AIR flowmeter (Max flow 12 l/min).
- V Selector switch for the exit of fresh gases (BREATHING SYSTEM or TO AND FRO).

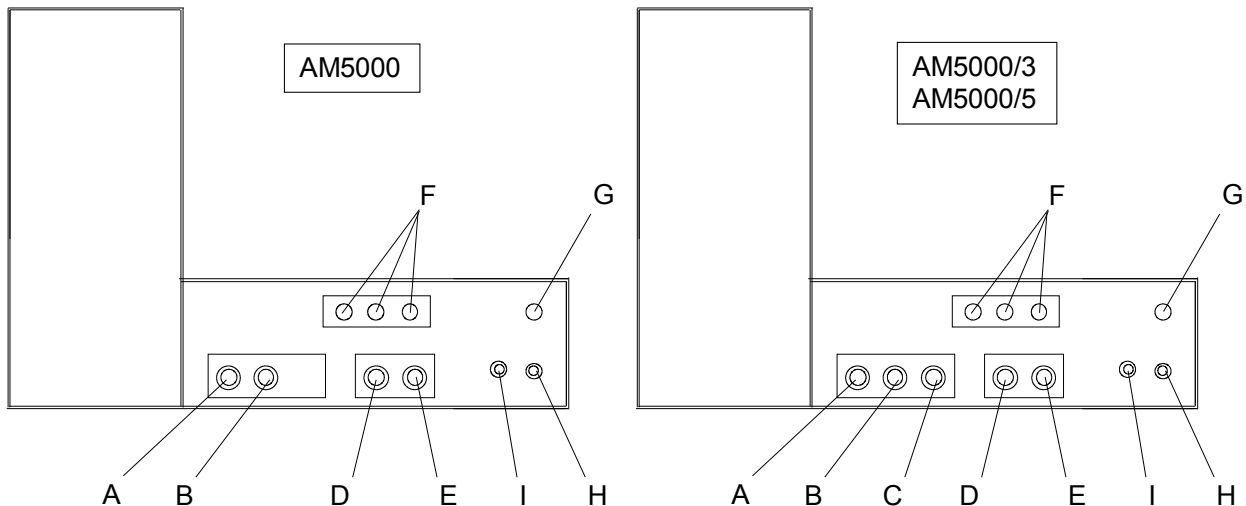

Back View

- A OXYGEN inlet from the main medical gas installation.
- B NITROUS OXIDE inlet from the main medical gas installation.
- C COMPRESSED AIR inlet from the main medical gas installation.
- D OXYGEN inlet from the cylinder's pressure reducer.
- E NITROUS OXIDE inlet from the cylinder's pressure reducer.
- F AIR/OXYGEN outlet for the supply of the lung ventilator, of the active scavenging system and the tracheal aspiration unit.
In optimal conditions these connector supply COMPRESSED AIR.
If there is no COMPRESSED AIR or there is not enough pressure, the unit automatically switches the distribution to OXYGEN.
- G These connectors are supplied standard with the machine if the relative accessories are in use
Emergency OXYGEN outlet.
- H Exit of fresh gases connector for TO and FRO.
- I FRESH GAS outlet for the *Breathing System*.

3.2 The Pneumatic Distributor

**NOTE: THE HERE BELOW INDICATED SCHEMES AND THE PROCEDURES, HAVE BEEN UNIFIED FOR THE THREE MODULES AM5000 – AM5000/3 – AM5000/5.
REMEMBER: DO NOT CONSIDER THE AIR LINE FOR ANAESTHESIA MODULE A 2 FLOWMETERS.**

Below is the pneumatic diagram which describes the unit:

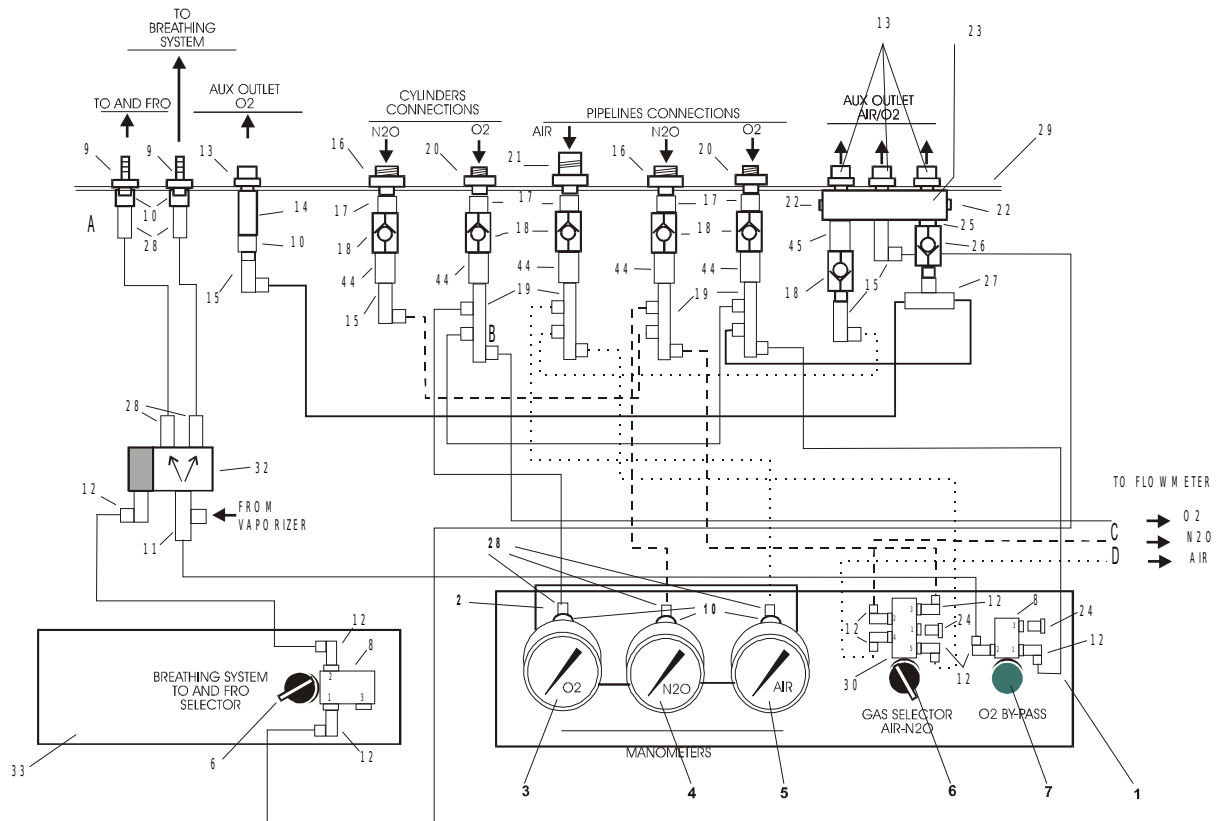

The main purpose of the pneumatic distributor is to:

1. take the medical gases from the pipeline connections or cylinder connections.
2. monitor the operating pressure (pressure gauges)
3. select the type of mix that should be administered to the patient (gas selector AIR-N2O)
4. take the selected gases to the flowmeter box
5. allow the mixed gases to be taken to the patient ventilation system (breathing system)
6. enrich the oxygen mixture in case of need (O2 bypass)

All the supply inlets are protected by a non-return valve, in order to avoid a leak of gas in case there is no supply.

As secondary functions, it allows:

supplies an auxiliary outlet of only oxygen which is automatically closed for connections to reanimation bags for emergencies,

supplies auxiliary outlet for O₂ and Air (Aux outlet Air/O₂) for devices such as the lung ventilator, ventury aspirator, etc...

The auxiliary outlets for Air/O₂ supply medical air if it has a pressure higher than that of the oxygen minus 0.5 bar. The non-return valves 18 and 26 are necessary in order to avoid that air and O₂ mix due to the pressure difference between the two gases' supply.

Each gas cylinder or pipeline supply conforms to the DISS standard in order to avoid mistakes in identifying the gases.

The gauges have a colored band indicating the range at which there is the correct supply pressure.

The gases supplied to the AM5000 - AM5000/3-AM5000/5 are connected to the flowmeter box in order to regulate the flows and to mix the gases that are then sent to the anaesthetic gas vaporizers. From these they are taken back to the AM5000 - AM5000/3-AM5000/5 in to later be sent to the connector for the fresh gas supply in the patient ventilation circuit. The gases mixed with the anaesthetic can be later mixed with pure oxygen for enrichment of the mix that can be done by the operator by using the bypass button.

The selector enables using two different types of breathing systems without disconnection between the tubes: the first is the patient circuit of the breathing system and the second, is the To and Fro, which is used for manual ventilation of the patient's breathing apparatus.

The following diagram illustrates the connections between the parts described above, in this case a flowmeter box with three flowmeters.

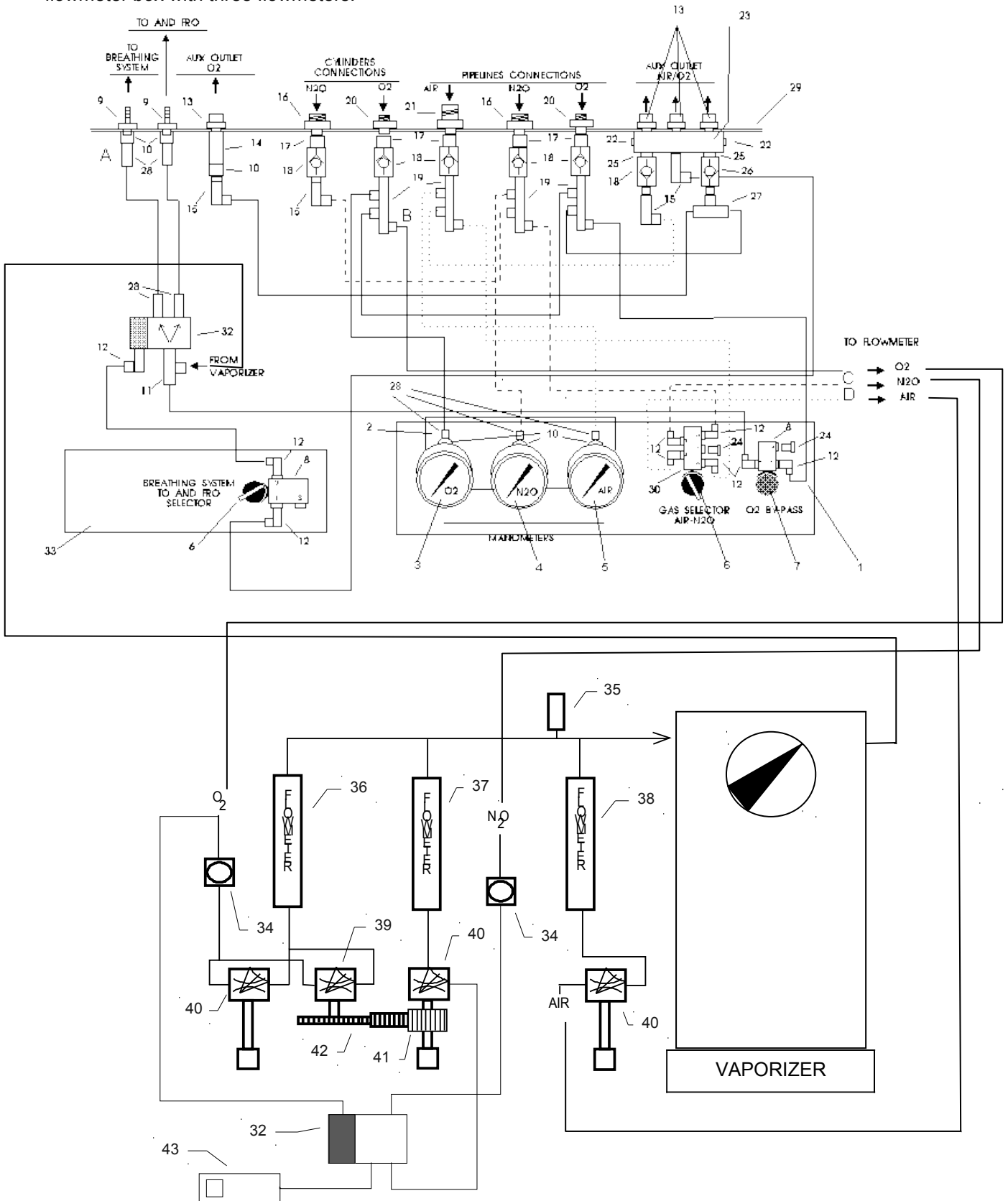

FLOWMETER BOX

Can be used in the two, three and five flowmeter models.

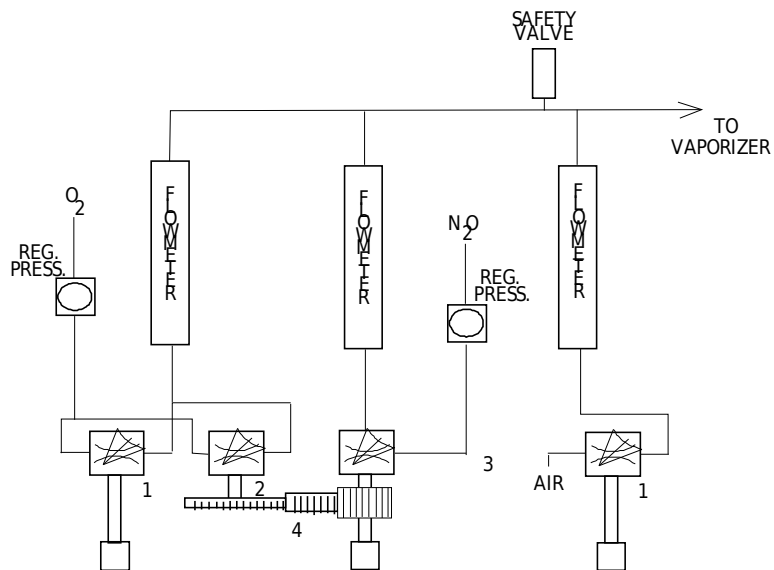
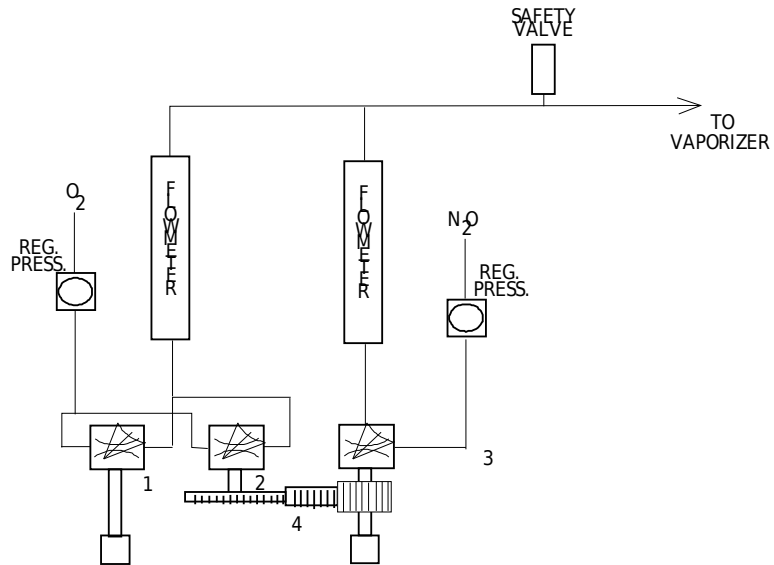

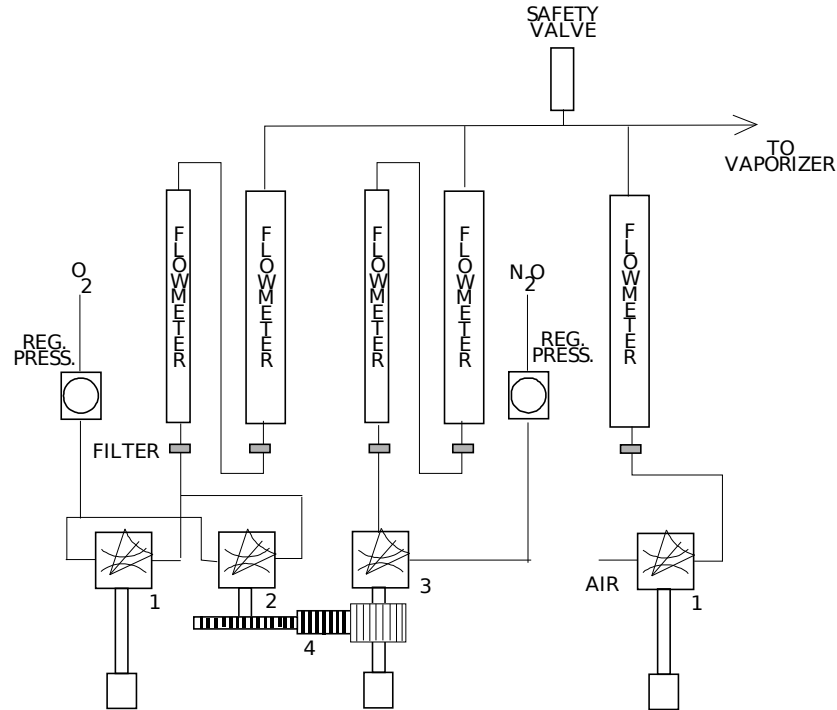

It does the MIX-LIFE function in order to guarantee that when the N₂O is supplied, the oxygen contents will never be lower than 25%. This function is done by a gear that controls the oxygen spout and is connected to the nitrous oxide handle.

There is also a safety valve that removes the air in the gas mix when, due to obstructions, in the down flow of the flowmeter box the pressure of the circuit is higher than 1 bar.

Another function that is not described in the diagram is the CUT-OFF, which is a valve (26) that when there is not O₂ deviates the N₂O supply flow the flowmeter (24) to a whistle (28) blocking the irrigation of N₂O to the patient and activating a audible alarm. This whistle warn the operator of the decrease in pressure of the oxygen supply and remains active while there is a problem.

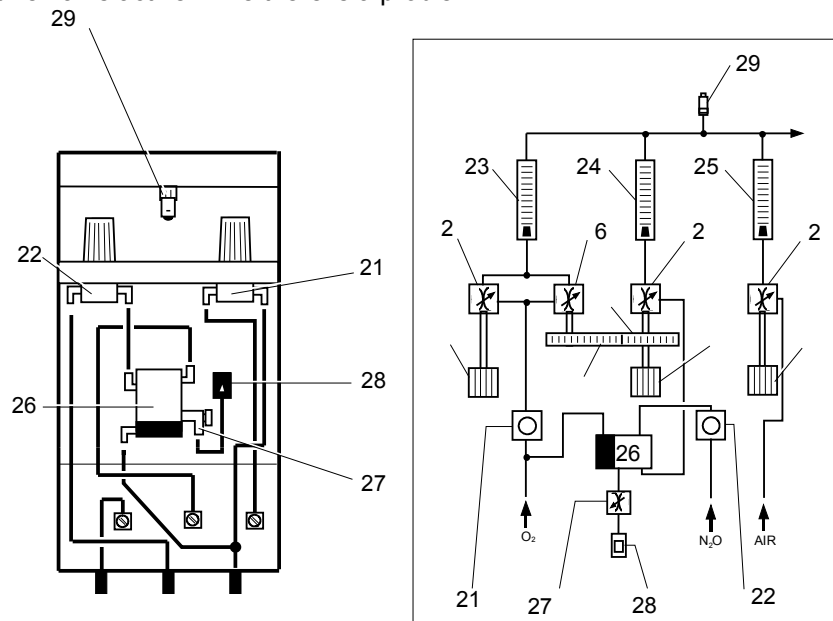

4. CALIBRATION AND TESTING

NOTE: THE HERE BELOW INDICATED SCHEMES AND THE PROCEDURES, HAVE BEEN UNIFIED FOR THE THREE MODULES AM5000 – AM5000/3 – AM5000/5.

REMEMBER: DO NOT CONSIDER THE AIR LINE FOR ANAESTHESIA MODULE A 2 FLOWMETERS.

4.1 Flowmeter Box

Procedure:

Preparation of the flow regulators of the Mix-life system

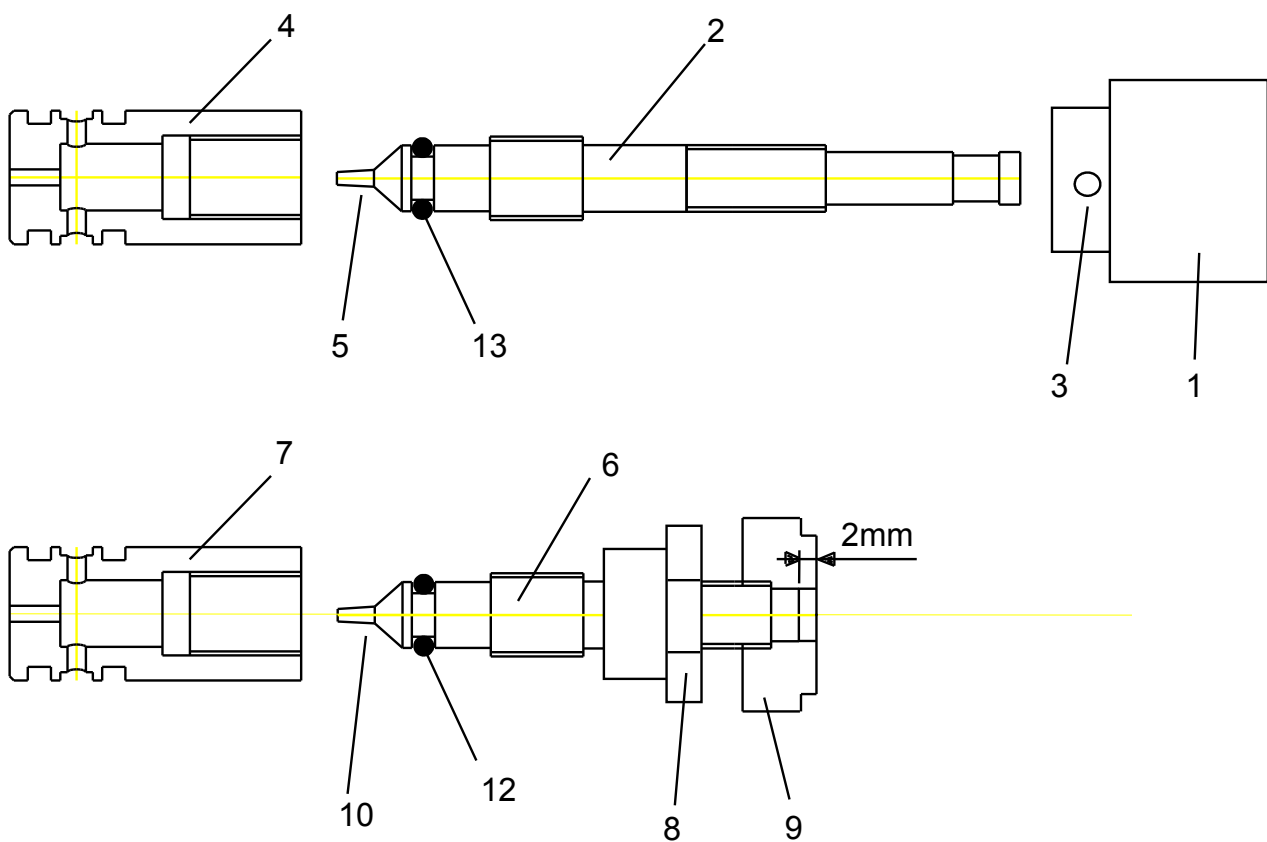

1a) wash properly all the metal components and dry them with compressed air

1b) insert knob 1 on the axis of pin 2 (oxygen, nitrous oxide, air) and block them with grain 3

1c) insert washer 8 onto the axis of pin 6 (mix-life system) and block with loctite 270 the flange 9 onto axis of pin 6 keeping a distance of 2mm0.5mm (wait at least 30 minutes before putting pressure onto washer 9)

1d) insert and lubricate with vaseline the o-ring 13 (OR 2018) onto the body of pin 2.

1e) lubricate with vaseline the edge and threading of pin 2.

1f) screw completely pin 2 on body 4 and pin 6 on body 7. Repeat about 5 times this procedure, screwing and unscrewing the pin of one turn.

1g) unscrew completely the pin and remove, with the sand paper, the brass deposits from edge 5 and 10 of the pin.

1h) repeat the procedures of points 1f and 1g until a good matching of the screws and mother screws are obtained and that the spacing between edge of pin and regulator body is created.

WARNING !!!: the procedures 1f and 1g are very important in order to have a good closure of the flow regulator, and if they are not done properly, it will be necessary to disassemble the flow regulators later.



- The metal components have to be properly washed and dried before assembly
- Properly check that there are no residue on the inside of the conductors and threading
- Blow all the components with compressed air before assembly

ASSEMBLY OF THE FLOW REGULATOR OF THE MIX-LIFE SYSTEM)

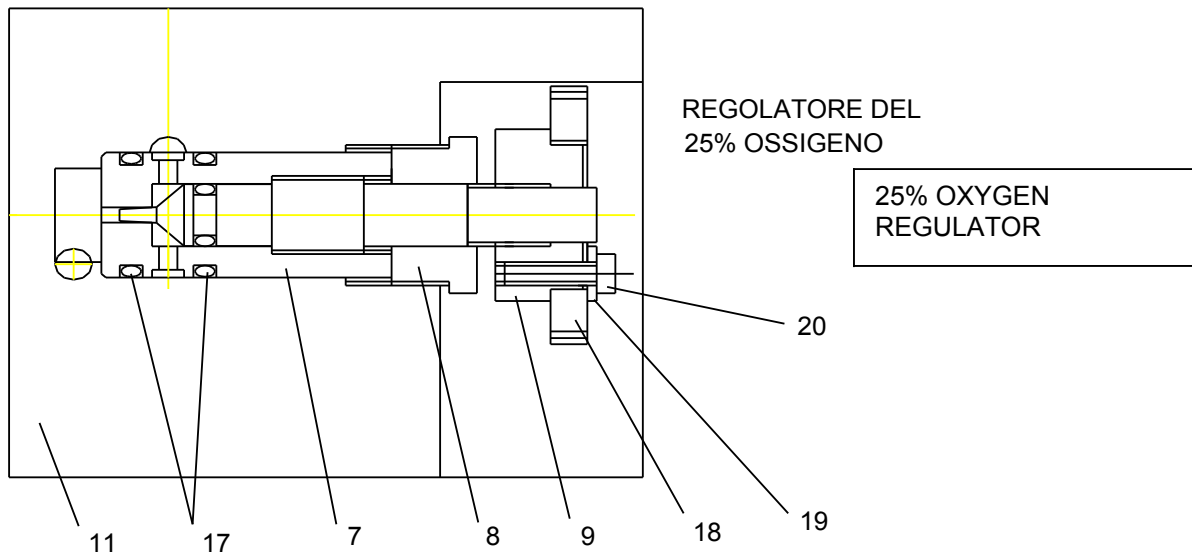
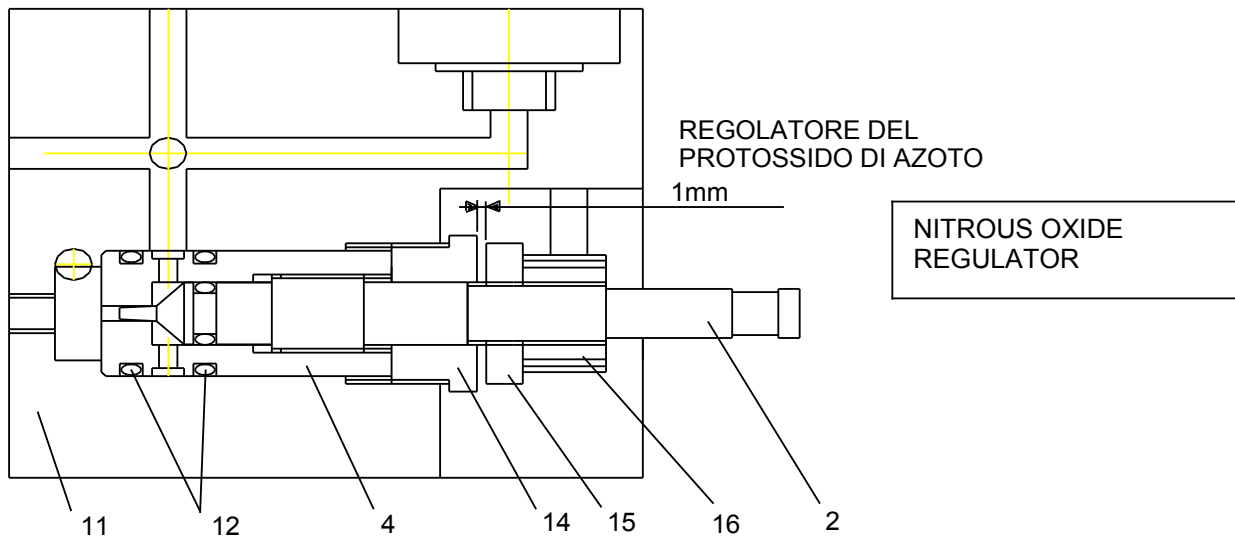

- 2a) Lubricate with Vaseline the whole for the regulators on block 11
- 2b) Assemble and lubricate with Vaseline the o-rings 17 on body 7
- 2c) Turn the regulator off by turning it counter-clockwise
- 2d) Insert body 7 on its whole in block 11.
- 2e) Tighten washer 8, with the proper tool
- 2f) Assemble and lubricate with Vaseline the o-rings 12 on body 4
- 2g) Turn the regulator off by turning it -clockwise).
- 2h) Insert body 4 on its whole in block 11
- 2i) Remove knob 1 which was assembled previously (see 1.b).
- 2l) Insert washer 14 on rod 2 and turn it with the proper tool
- 2m) Screw the bolt 15 , leaving about $1\text{mm} \pm 0.2\text{mm}$. between grill 14 and bolt 15.
- 2n) -screw the gear 16 up to bolt 15, and tighten without the use of tools, making sure that bolt 15 is fixed at 1mm from washer 14.
- 2o) Insert gear 18 onto flange 18 and screw without tightening the screw (screw TCEI zinc. M3x6) with its washer 19 (flat washer M3).
- 2p) Insert between the teeth of the gears (from the upper side) a piece of soft PVC in order to block the reciprocal rotation, therefore tighten with the proper tool the bolt 15 without excessive force.
- 2q) Remove the piece of PVC and verify that the rotation of the regulators is regular and without interference.
- 2r) Lubricate the gears with a little bit of Vaseline.

- 2s) Screw the filters/silencers 1/8 whole 5.5, on the flowmeters holes of the regulator block
- 2t) Insert the gasket 15x24x7 in the flowmeter holes of the regulator block .
- 2u) Screw the connectors M5 ALU 6 onto the regulator block, on the rear of the regulator area.
- 2v) Insert an OR 3043 in each of the flowmeter compartments on the regulator block.

3) Circuit and regulator leak test



Note: In the following assembly phases, do not use sealing products or Teflon.

- 3a) Assemble at the entry point of the pressure regulators AR 1000 (21 and 22) 1 connector M5 ALU 6 and in exit point 1 connector RG 6/5.
- 3b) Assemble in the front of the servocontrol 26, 1 connector M5 ALU 6, in entry point (letter A on servocontrol) 1 connector RG 6/8, in exit point (letter P on servocontrol) 1 connector RG 6/8 and in exit point (letter R on servocontrol) 1 regulator RE RG 6/8.
- 3c) Insert a piece of light blue extraflex tube (diameter 6mm, length 10 cm) in the central part of the inlet of the whistle 28, seal the rest of the whistle with a light blue extraflex tube (diam 4 mm, length 10 cm), with instantaneous universal adhesive (supper attack).
- 3d) For the 3 gas flowmeter box :
Make the connections as per the diagram and drawings that follow:

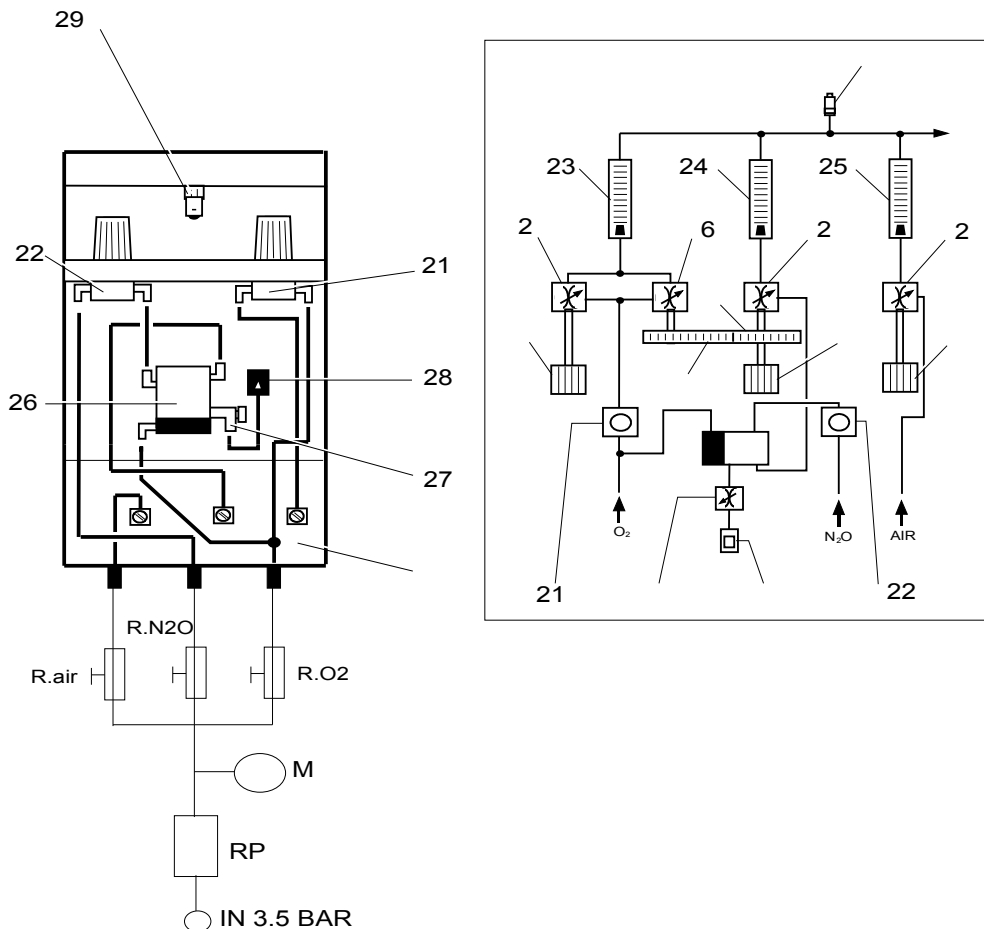

- 3e) Insert the flowmeters in their compartments (looking at the regulator block with the regulator located in the front), O2 flowmeter on the left, N2O flowmeter in the middle, and AIR flowmeter on the right.



The flowmeters should be handled with care, and should be wrapped in the paper in which they were shipped, not with nylon.

Do not rub them with your hands, fabric or paper.

- 3f) All the tarring and flowmeter checks should be done with compressed air at 3.5 bar.
 - 3g) With the flow regulators closed, regulate the pressure of the oxygen (21) at 2 bar and that of the nitrous oxide (22) at 1.4 bar. Insert and remove the compressed air supply 3 times so that the reducers are stabilized, if necessary correct the regulation.
 - 3h) The leak test should be checked in two points:
 - 1) - down from the valves (2, 6) in order to check the proper that there are not leaks in the closure of the valves.
 - 2) - up from the valves (2, 6) in order to check the proper that there are not leaks in the pneumatic circuit.
- 1) Verify that the leak of each valve connecting the flowmeter corresponding to a low flow gauger. The measured leak should not be higher than 20 ml/min. for the O₂, N₂O, Air.

The lack of significant leak should be guaranteed without forcing the regulator.

If there is a significant leak it can be due to two factors

-a manufacturing defect that affects the hold of the pins (this is the most probable cause).

In this case it is necessary to repeat the preparation for operation of the regulator. If after two tries the hold of the group BODY- PIN (2-4 or 6-7) it should be replaced

- manufacturing defect that affects the hold of one of the o-rings (check that their surface is not damaged during the assembly due to a residual deposit)

2) Always with the closed flow regulators close the air supply up from the control gauge (M) and verify that the pressure does not go lower than 0.5 bar in 1 minute for all the 3 gas lines at the same time.

If the decrease in pressure is higher, there is a leak in the pneumatic circuit.

Verify the proper connection of the tubes and connector, and if the leak continues use the leak tester with bubbles in the points of connections of the connectors and on the pressure reducers.

4) Check for flowmeter capacity



4a) In order to check the capacity 1.00, 4.00 l/min of the O₂ connect the O₂ flowmeter 23 with a tube at the start of a low flow gauger

Regulate the O₂ flowmeter in order to take the bubble indicator to 1.00, 4.00 l/min of the scale of the flowmeter.

In order to verify the capacity 8.00, 12.00 l/min of O₂ connect the O₂ flowmeter with a tube at the start of a high flow gauger.

Regulate the knob of the O₂ flowmeter in order to place the bubble indicator corresponding to the values 8.00, 12.00 l/min of the scale of the flowmeter.

The flowmeter delivers a correct dosage if the values read on the flow gauger, as per the following table:

Set. O ₂ flow	Measured Air	Acpt. limit. ±10%	
		MIN	MAX
1,00		1,00	1,22
4,00		3,96	4,85
8,00		7,70	9,41
12,00		11,43	13,97

4b) Repeat the same steps for the N2O flowmeter.

Set. N2O flow	Measured Air	Acpt. limit. ±10%	
		MIN	MAX
1,00		0,93	1,14
4,00		4,15	5,08
8,00		8,46	10,35
12,00		12,95	15,82

4c) Repeat the same steps for the AIR flowmeter.

Set. AIR flow	Measured Air	Acpt. limit. ±10%	
		MIN	MAX
1,00		0,90	1,10
4,00		3,60	4,40
8,00		7,20	8,80
12,00		10,80	13,20

5) Tarring the flow regulator and Mix-Life pressure system. 

The MIX-LIFE is designed to administer the minimum possible dosage of oxygen when the nitrous oxide regulator is opened.

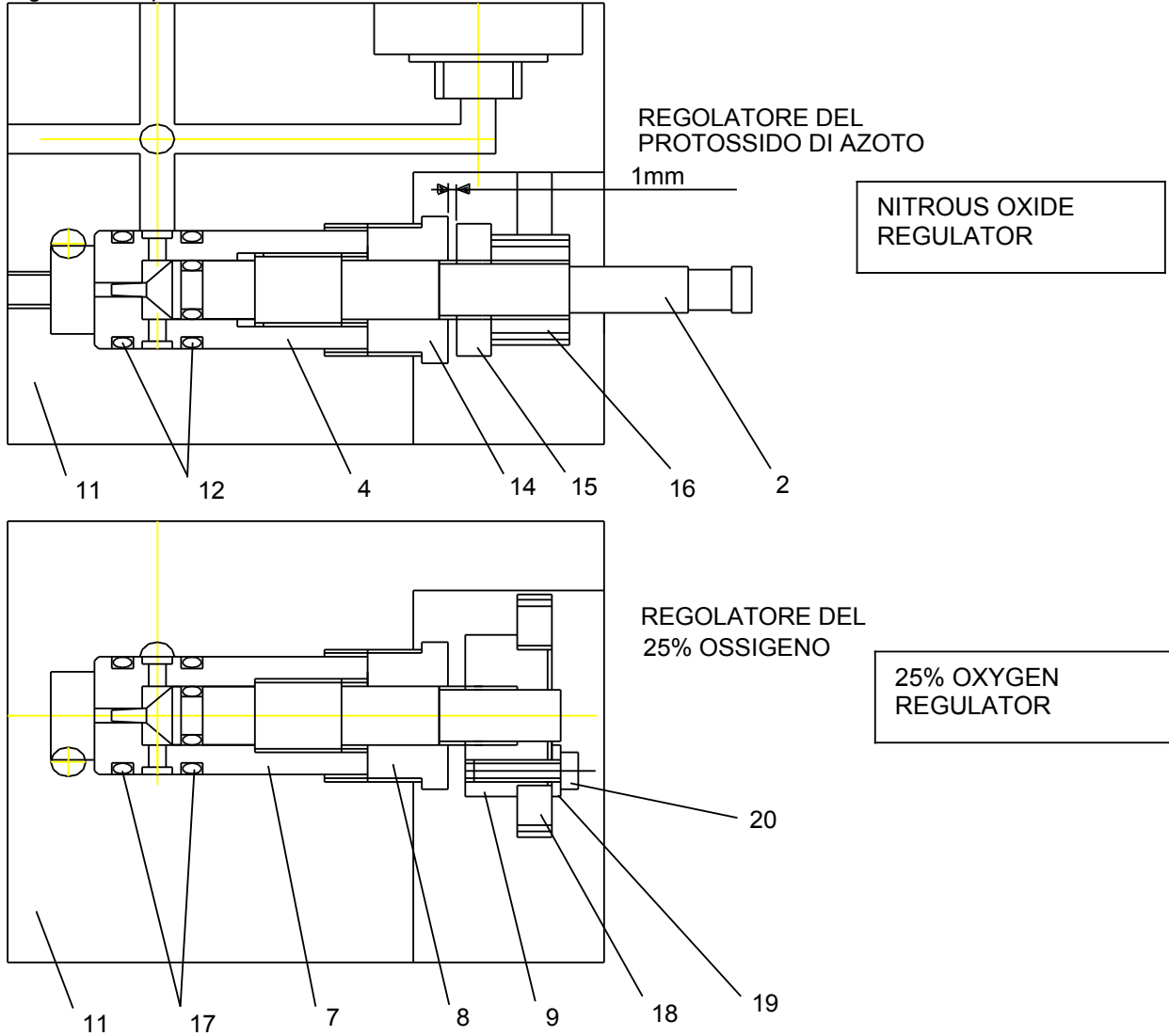

5a) Close all the regulators .

5b) Tighten the screws 20.

5c) Open the valve of N₂O (the valve O₂ will also open automatically) check that opening the N₂O valve in way to have the liters per minute indicated on the following table:

MIX-LIFE system set.N ₂ O flow	O ₂ Meas open.	O ₂ Meas closed	O ₂ limit	
			MIN	MAX
1,00			0,25	0,5
2,00			0,5	1
4,00			1	2
6,00			1,5	3
8,00			2	4
10,00			2,5	5
12,00			3	6

It is rare that the tolerances are within the limits on the first try, however by the trend of the values you will receive the information necessary for doing the corrections.

The following scenarios are possible:

- O2 percentage tends to be higher than 25%
- O2 percentage tends to be lower than 25%

This problem is due mainly to the pressure and secondly to the phase between the gears.

If the O2 percentage tends to be higher than 25%, the pressure of the N2O needs to be increased.

If instead the O2 percentage tends to be lower than 25%, the pressure of the N2O needs to be decreased.

Each time the regulator is readjusted it is necessary to connect and disconnect 3 times the compressed air supply, so as to stabilize, if necessary adjust the regulation.

- 5d) Repeat the operation from point 5 until the values are not within the tolerances indicated on point 5C.
- 5e) Due to mechanical play that can occur in threads and gears, the values that are read in opening and closing will be slightly different. On the tarring form, the operator should write down both of these values, that should be within the tolerance in the worst condition.. The difference between the values in opening and closing will be more significant on low flows.

In time, due to the usage of the machine, the O2 percentage will tend to increase, instead of decreasing. This is important as far as the safety.

- 5f) The tarring will again be checked, once the assembly of the flowmeter box is completed.

6) Assembly of flowmeter box

- 6a) Remove the flowmeters and supply tubes from the regulator block
- 6b) Insert 1 gasket and 1 OR 2050 in each upper lodging of the flowmeter from the upper block of the flowmeter box.
- 6c) Screw the safety valve on the upper block of the flowmeter box.
- 6d) Assemble the pressure reducers AR 1000 onto the reducer support, keeping the N2O reducer to the left, and the O2 to the right (place the reducer support with the holes facing the front)
- 6e) Assemble the right and left panel on the regulator block with screws TSEI M3x6, (verify before assembling the panels that the head of the flat screws is completely hidden in its lodging, otherwise adjust the lodging.
- 6f) Place the flowmeters on their lodgings.
- 6g) Place the internal panel so that the flowmeters are visible when looking the flowmeter box from the front.
- 6h) Set the reducer support on the upper part of the right and left panels, so that it covers the body of the pressure reducers can be seen from the back, with 2 flat screws self-threading M3x10 .
- 6i) Assemble the upper block of the flowmeter box with screws TSEI M3x6.

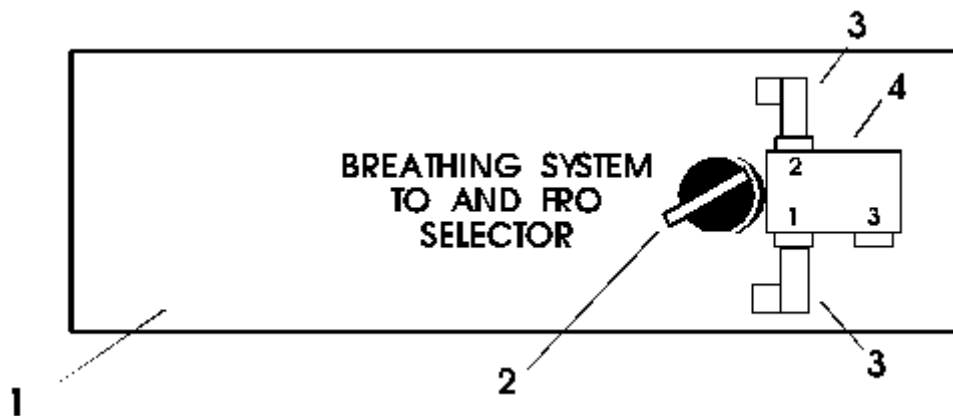

- | | | | |
|----|------------------------------------------------|------------------|------|
| 1. | Lower front panel of the flowmeter box AM 5000 | (cod. M55682809) | n. 1 |
| 2. | Selector | (cod. P13000049) | n. 1 |
| 3. | Connector RG 6/5 | (cod. P00100109) | n. 2 |
| 4. | 3-way pneumatic valve | (cod. P10000079) | n. 1 |

- Screw the connectors (3) to the 3-way pneumatic valve (4) in points 1 e 2, and set the selector (2) to the lower panel (1) and to the valve (4) so that when the white line of the selector is over the writing TO AND FRO and BREATHING SYSTEM.
- Stick the sticker to the 3 gas s flowmeter box, after having removed the protective plastic film.
- Cut a hole on the sticker at the same height as the holes on the Plexiglas for the exit of the regulator body pin, so that there are 3 holes of the same dimension as the hole on the Plexiglas.
- Set on the cover of the the structure.
- Insert on the rails of the structure the front panel.
- Set the protection for the flowmeter box with silicone with the front panel.
- Place the lower panel with selectors and valve on the lodgings of the structure.
- Set the knobs of the different gases on the pin to its corresponding flowmeters by the grain, so that with the valve completely closed the knob is at a distance of 1 ± 0.2 mm from the Plexiglas.

7) Maximum pressure valve tarring



- 7a) The maximum pressure valve is designed to prevent the glass rotameters from breaking due to an accidental obstruction on the distribution line of the gaseous mix.
This operation should be done once the assembly of the flowmeter box is done, before closing the back panel of the unit.
- 7b) Loosen the valve and assemble on the exit connector of a 0-6 bar gauge.
- 7c) Connect the triade with the gauge to the flowmeter box.
- 7d) Open flow of the oxygen to 12 l/min.
- 7e) Obstruct the fresh gas exit after the gauge, in this way the gas will exit from the valve.
- 7f) Slowly close the valve until the manometer shows a pressure between 0.7 e 0.8 bar
- 7g) Tighten the grill of the valve making sure not to change its regulation .

8) Cut-Off Check

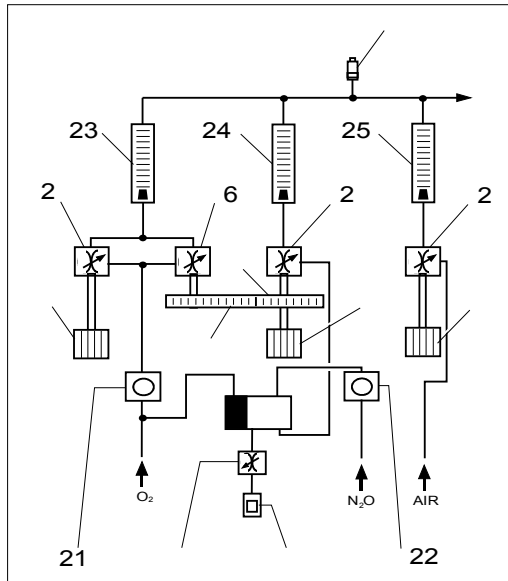
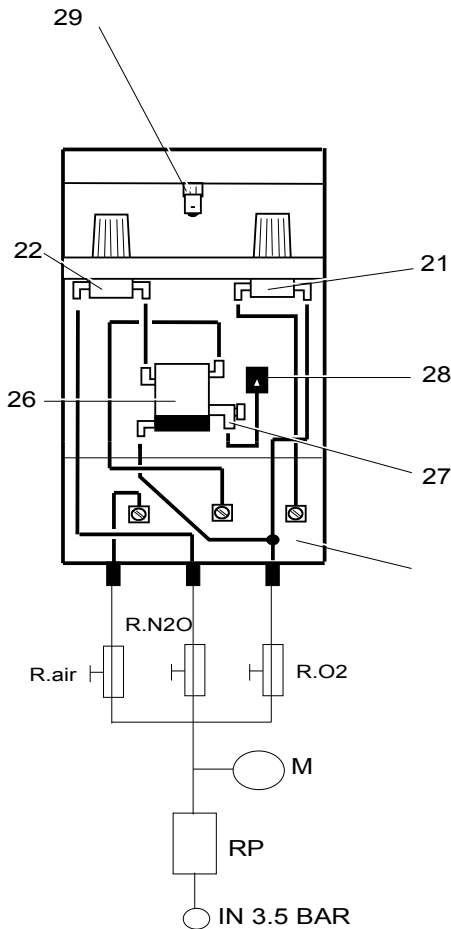

- 8a) The CUT-OFF safety device is designed to block the delivery of nitrous oxide in case of lack of oxygen in the inlet of the flowmeter box and of warning the operator by emitting an audible alarm, that there is a dangerous situation.
 In order to activate the device, open the valve of the N₂O and the O₂, close R.O₂; in this situation the N₂O exits from regulator 27.
- 8b) Regulate the flow by tightening the valve of the regulator until the audible alarm, that is emitted from whistle 28, does not reach its maximum value.
- 8c) Tighten the grill at the bottom of the valve of the regulator.
- 8d) In order to check the proper operation of this device, open the nitrous oxide flow and the oxygen and close the valve of the oxygen R.O₂ of triade of gas supply of the flowmeter box and check first the oxygen flowmeter indicator and then the nitrous oxide go to 0 and the an audible alarm is emitted.

4.2 Final Test

PROCEDURE:

1.connect the following pneumatic connections:

AM5000:

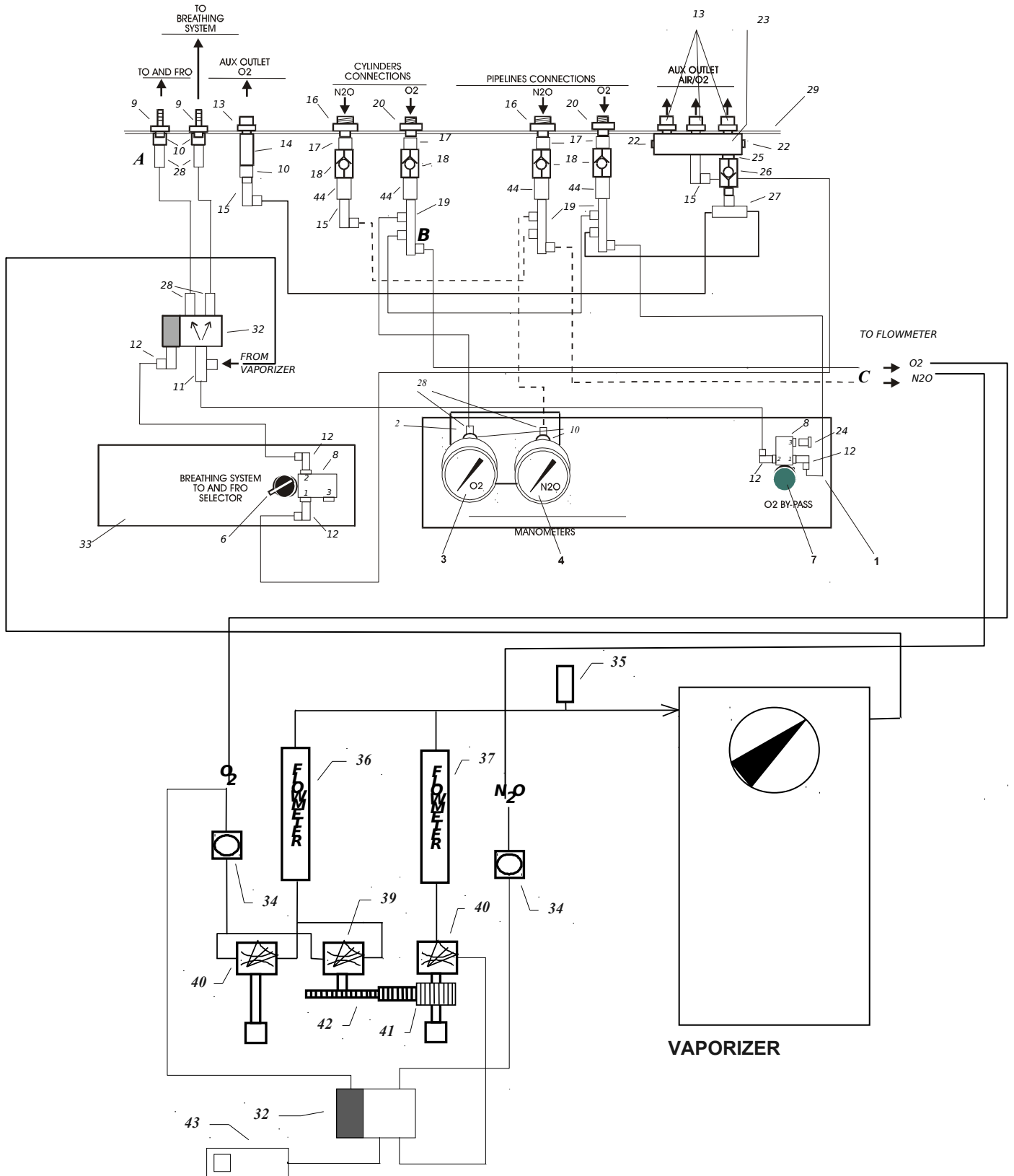

AM5000/3:

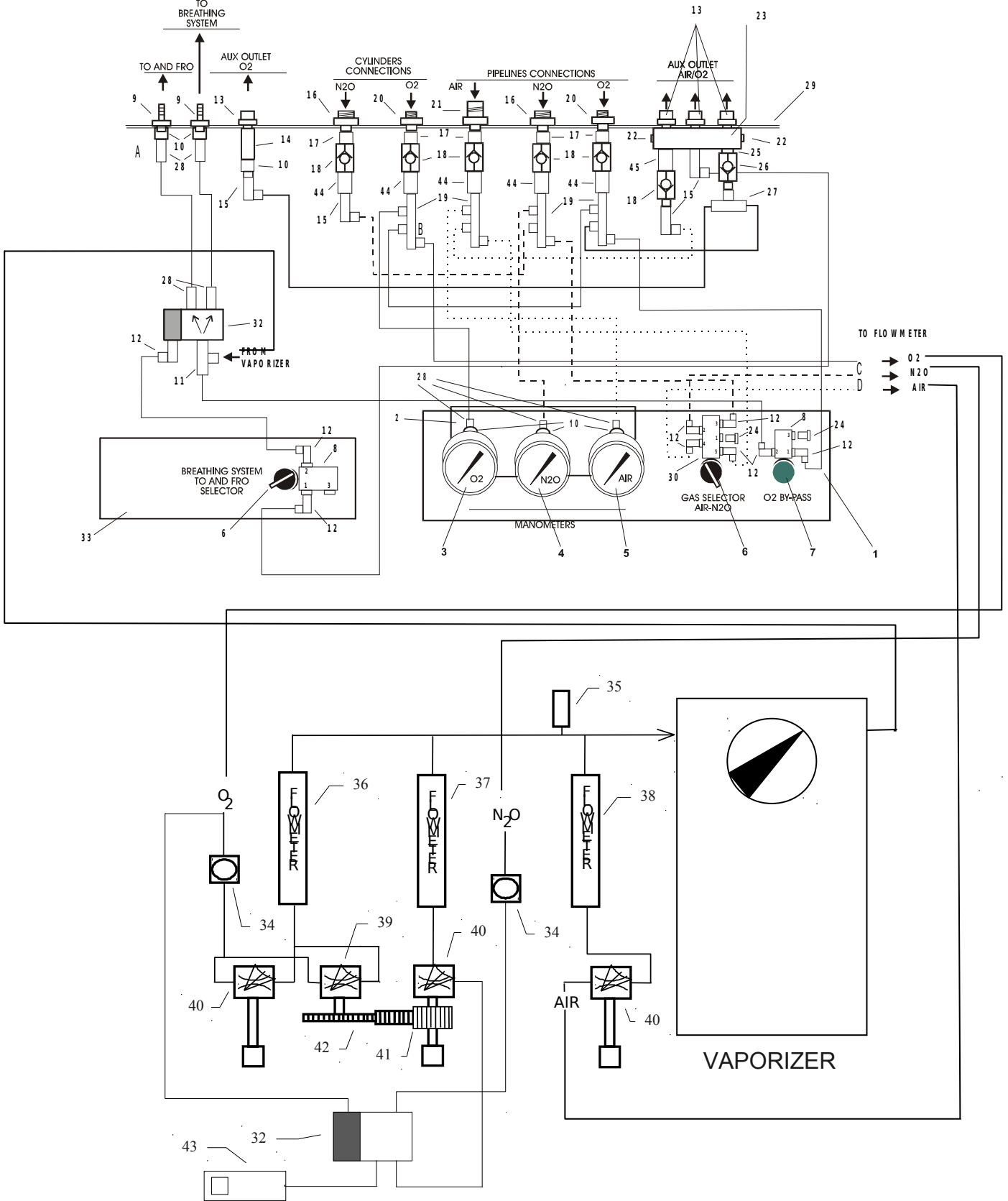

AM5000/5:

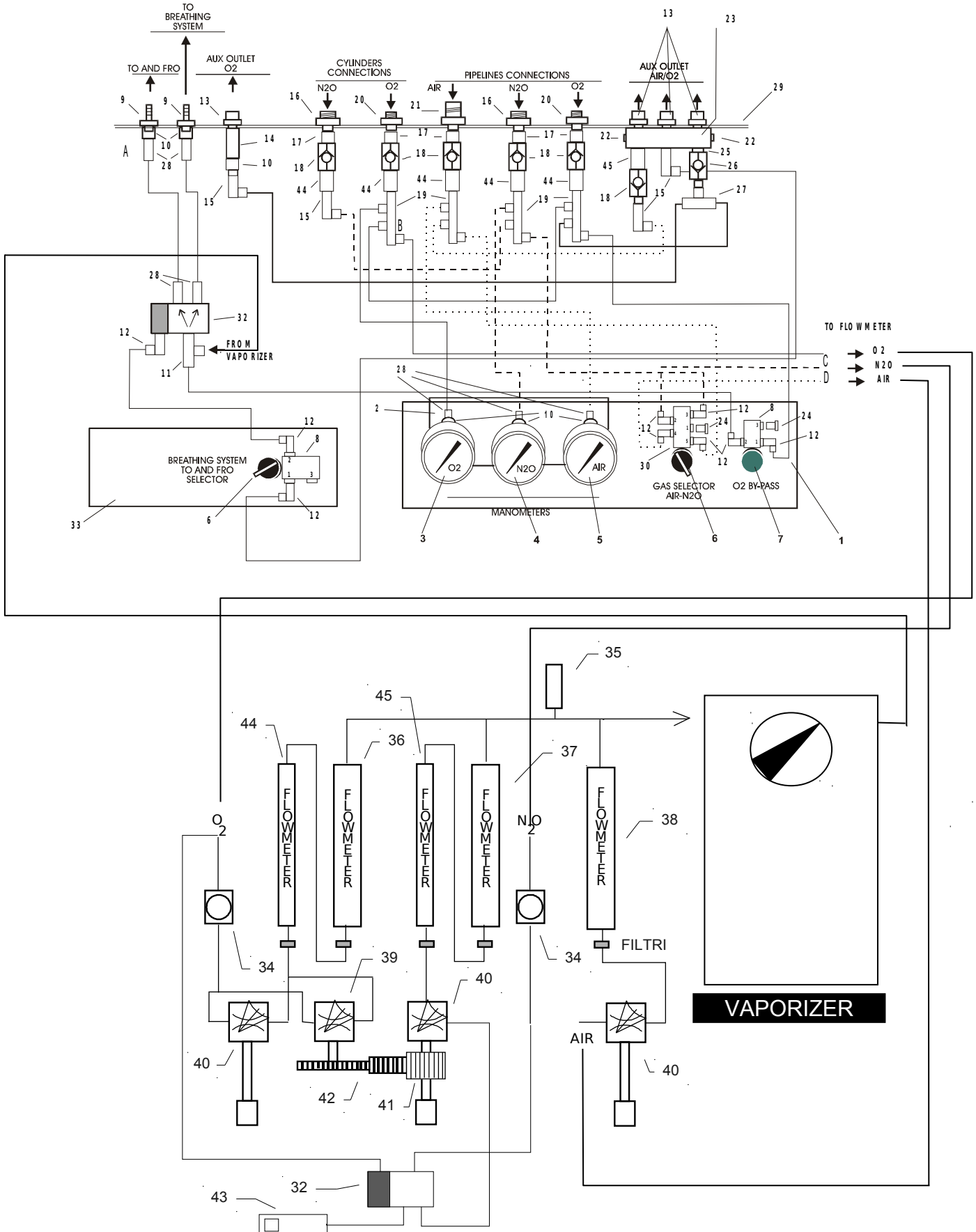

Preparation:

insert supply biad with the valves and manometers at 16+20 (cylinder connections)

insert supply triad with valves and manometers at 16+20+21 (pipeline connections)

Leak Test

open the main valve of the triad, closed the main valve of the biad and close the valves of the flowmeter box. Close the 3 gas valves of the triad, the pressure indicated on the 3 manometers should not be < than 3 bar after 30 seconds.

BY PASS TEST

Open the main valve of the triad, open the O2 valve and closed the N2O and Air valve. Connect the connector 9 by using a tube in the entrance of the High Flow Range of a flow gauger.

Press the O2 Bypass button and the flow read on the flow gauger should be 66 l/min +/- 20%.

GAS SELECTOR TEST

open the main valve of the triad and open the 3 valves of the 3 ways of the triad

Set the selector on N2O and open the N2O valve of the flowmeter box, the indicator of the flowmeter of the N2O does not go up and from connector 9 (see pneumatic diagram) exits air, close the air valve of the triad and from connector 9 exits air still, close the N2O valve of the flowmeter box.

Put the selector on air, open the air valve of the flowmeter box, the indicator of the air flowmeter goes up and from connector 9 (see diagram) exits air, close the N2O valve from the triad and from connector 9 exits air still, close the air valve of the flowmeter.

AUX OUTLET TEST

open the main valve of the triad, open the air valve and close the N2O and O2 valve, pressing the inside of the valve "AUX OUTLET AIR/O2" exits air and pressing the inside of the valve "AUX OUTLET O2" does not exit anything.

Now close the air valve and open the O2 valve, pressing the inside of all the "AUX OUTLET" valves exits air.

CYLINDER CONNECTION TEST

a. open the main valve of the triad and biad, open all the gas valves of the triad and the biad, close the general valve of the triad observe that the manometer of the air goes to 0 and that the O2 manometers and N2O go down in pressure and return immediately to the pressure indicated on the manometer of the biad.

5. PNEUMATICS

5.1 Pneumatic Diagram AM5000

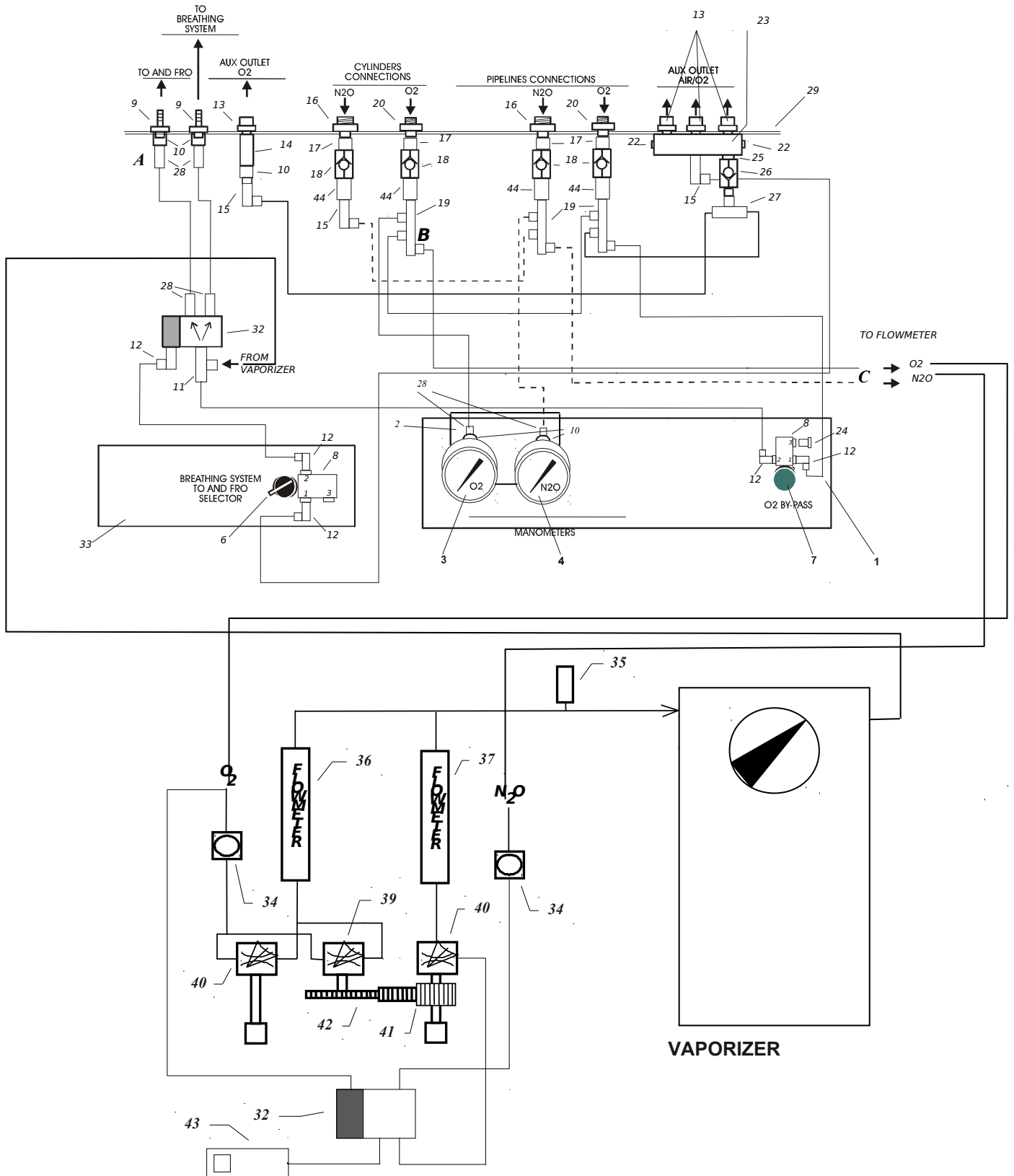

5.2 Components List FOR AM 5000/

1.	front panel of AM 5000	(cod. M55679709)	n.1
2.	manometer support AM 5000	(cod. M58481209)	n.1
3.	oxygen manometer	(cod. P40100009)	n.1
4.	nitrous oxide manometer	(cod. P41100009)	n.1
6.	selector switch	(cod. P13000049)	n.1
7.	green button	(cod. P13000059)	n.1
8.	pneumatic valve with 3 openings	(cod. P10000079)	n.2
9.	Connector M1/8 tube 6	(cod. P05000019)	n.2
10.	Fem./Fem. connector 1/8	(cod. P04000019)	n.5
11.	Connector RL 6/8	(cod. P00200039)	n.1
12.	Connector RG 6/5	(cod. P00100109)	n.5
13.	Carbuross O2 plug	(cod. P07900079)	n.4
14.	Extension MF1/8	(cod. P02900029)	n.1
15.	Connector RG 6/8	(cod. P00100029)	n.3
16.	Inlet Connector N2O	(cod. M57000809)	n.2
17.	Reducer F1/4 M1/8	(cod. P04800039)	n.4
18.	Non -return valve 1/8	(cod. P16000029)	n.4
19.	Triple connector RG 6/8	(cod. P00100139)	n.3
20.	O2 Inlet connector	(cod. M57000609)	n.2
22.	Cap hex screw ¼	(cod. P09900099)	n.2
23.	8 way distributor	(cod. P04500059)	n.1
24.	Cap M5	cod. P09900179)	n.1
25.	Nipples 1/8	(cod. P04700009)	n.1
26.	Modified Non return valve 1/8	(cod. P16000059)	n.1
27.	Connector RT 6/8	(cod. P00200069)	n.1
28.	Connector RD 6/8	(cod. P00000049)	n.6
29.	Back panel AM 5000	(cod. M55677529)	n.1
32.	Servocontrol 1/8 M5 SMC	(cod. P09900179)	n.2
33.	Lower flowmeter panel AM5000	(cod. M55682809)	n.1
34.	Pressure regulator AR 1000-M5	(cod. P20000039)	n.2
35.	Safety valve 1/8 spring 2	(cod. P17000009)	n.1
36.	O ₂ flowmeter 0-12 l/min	(cod. P50200009)	n.1
37.	N ₂ O flowmeter 0-12 l/min	(cod. P51200009)	n.1
39.	Regulator 25% flowmeter box	(cod. M58050309)	n.1
40.	Regulator flowmeter box.	(cod. M58050209)	n.2
41.	N ₂ O gear flowmeter box.	(cod. M54270709)	n.1
42.	Gear 25% O ₂ flowmeter box	(cod. M54270809)	n.1
43.	Plastic whistle	(cod. M23290009)	n.1
44.	Connector F1/8 F1/8	(cod. P4000019)	n.1

5.3 Pneumatic Diagram AM5000/3

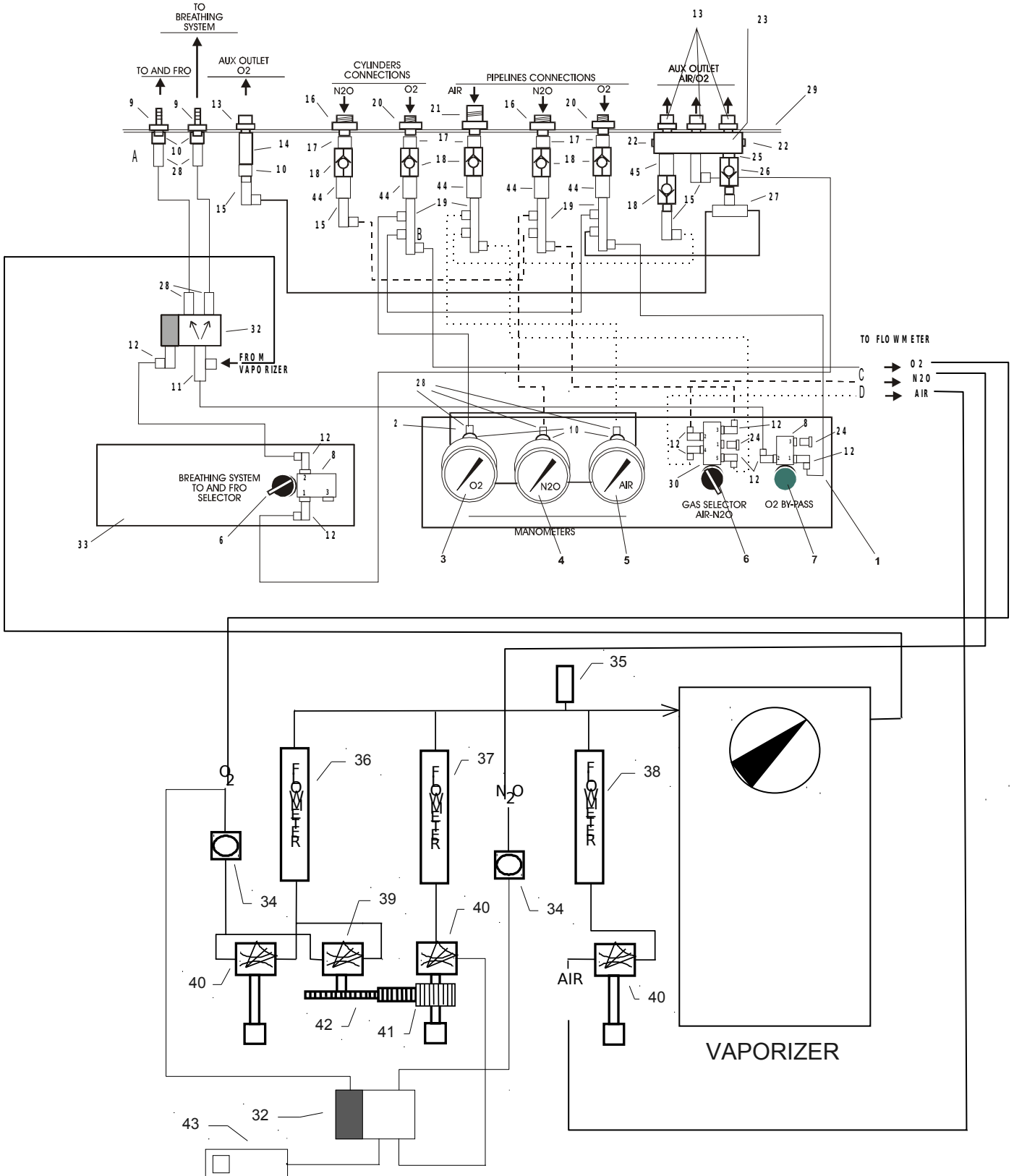

5.4 Components List FOR AM 5000/3

1.	Front panel of AM 5000	(cod. M55679709)	n.1
2.	manometer support AM 5000	(cod. M58481209)	n.1
3.	oxygen manometer	(cod. P40100009)	n.1
4.	nitrous oxide manometer	(cod. P41100009)	n.1
5.	air manometer	(cod. P42100009)	n.1
6.	selector switch	(cod. P13000049)	n.2
7.	green button	(cod. P13000059)	n.1
8.	pneumatic valve with 3 openings	(cod. P10000079)	n.2
9.	Connector M1/8 tube 6	(cod. P05000019)	n.2
10.	Fem./Fem. connector 1/8	(cod. P04000019)	n.6
11.	Connector RL 6/8	(cod. P00200039)	n.1
12.	Connector RG 6/5	(cod. P00100109)	n.9
13.	Carbuross O2 plug	(cod. P07900079)	n.4
14.	Extension MF1/8	(cod. P02900029)	n.1
15.	Connector RG 6/8	(cod. P00100029)	n.4
16.	Inlet Connector N2O	(cod. M57000809)	n.2
17.	Reducer F1/4 M1/8	(cod. P04800039)	n.5
18.	Non -return valve 1/8	(cod. P16000029)	n.6
19.	Triple connector RG 6/8	(cod. P00100139)	n.4
20.	O2 Inlet connector	(cod. M57000609)	n.2
21.	Air Inlet connector	(cod. M57000709)	n.1
22.	Cap hex screw ¼	(cod. P09900099)	n.2
23.	8 way distributor	(cod. P04500059)	n.1
24.	Cap M5	Cod. P09900179)	n.2
25.	Nipples 1/8	(cod. P04700009)	n.1
26.	Modified Non return valve 1/8	(cod. P16000029)	n.1
27.	Connector RT 6/8	(cod. P00200069)	n.1
28.	Connector RD 6/8	(cod. P00000049)	n.7
29.	Back panel AM 5000	(cod. M55677509)	n.1
30.	Valve pneumatic 5 way	(cod. P10000089)	n.1
32.	Servocontrol 1/8 M5 SMC	(cod. P09900179)	n.2
33.	Lower flowmeter panel AM5000	(cod. M55682809)	n.1
34.	Pressure regulator AR 1000-M5	(cod. P20000039)	n.2
35.	Safety valve 1/8 spring 2	(cod. P17000009)	n.1
36.	O ₂ flowmeter 0-12 l/min	(cod. P50200009)	n.1
37.	N ₂ O flowmeter 0-12 l/min	(cod. P51200009)	n.1
38.	AIR flowmeter 0-12 l/min	(cod. P52200009)	n.1
39.	Regulator 25% flowmeter box	(cod. M58050309)	n.1
40.	Regulator flowmeter box.	(cod. M58050209)	n.3
41.	N ₂ O gear flowmeter box.	(cod. M54270709)	n.1
42.	Gear 25% O ₂ flowmeter box	(cod. M54270809)	n.1
43.	Plastic whistle	(cod. M23290009)	n.1
44.	Connector F1/8 F1/8	(cod. P04000019)	n.5
45.	Connector L1/8 MF	(cod. P04100089)	n.1

5.5 Pneumatic Diagram AM5000/5

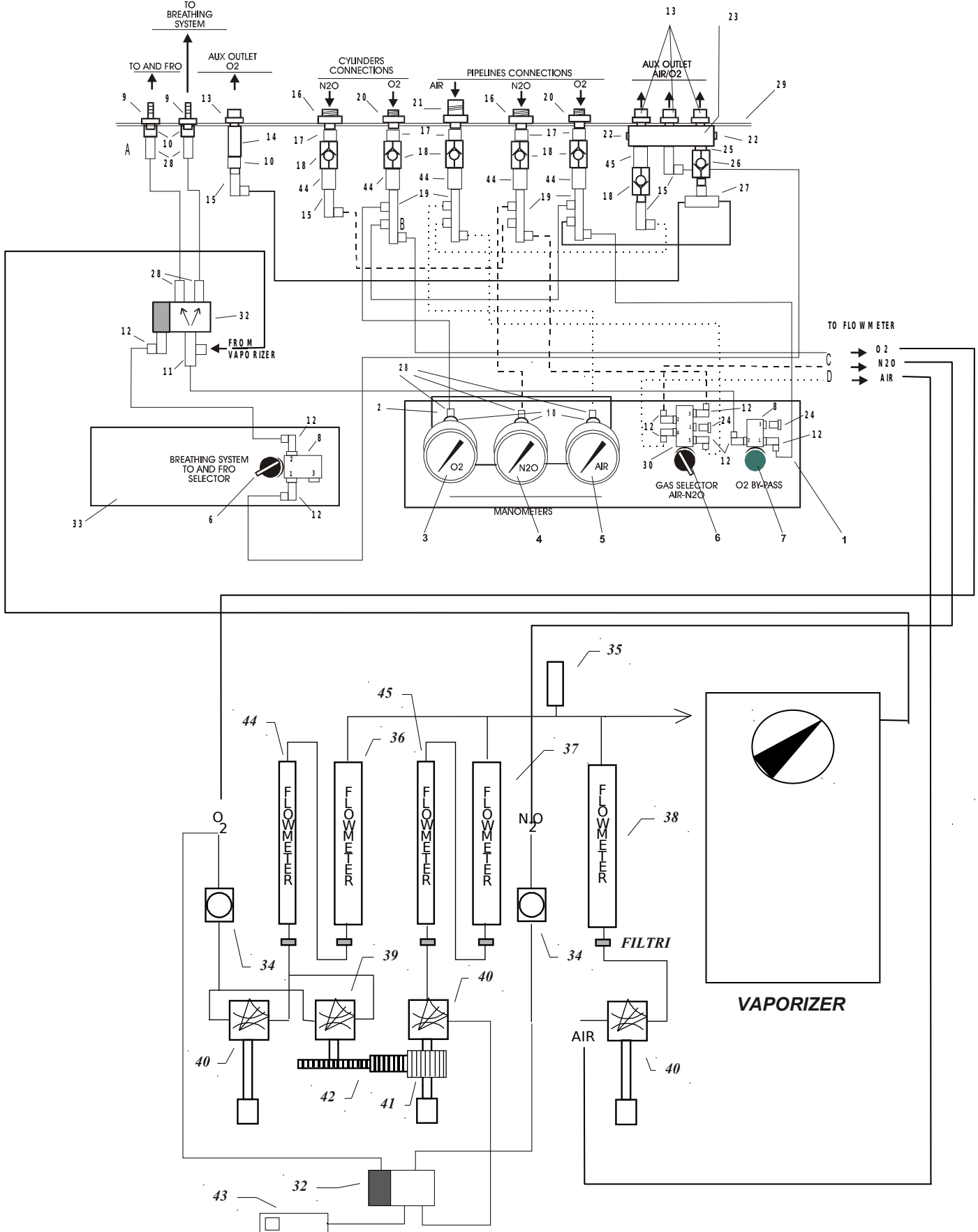

5.6 Components List FOR AM 5000/5

1.	front panel of AM 5000	(cod. M55679709)	n.1
2.	manometer support AM 5000	(cod. M58481209)	n.1
3.	oxygen manometer	(cod. P40100009)	n.1
4.	nitrous oxide manometer	(cod. P41100009)	n.1
5.	air manometer	(cod. P42100009)	n.1
6.	selector switch	(cod. P13000049)	n.2
7.	green button	(cod. P13000059)	n.1
8.	pneumatic valve with 3 openings	(cod. P10000079)	n.2
9.	Connector M1/8 tube 6	(cod. P05000019)	n.2
10.	Fem./Fem. connector 1/8	(cod. P04000019)	n.6
11.	Connector RL 6/8	(cod. P00200039)	n.1
12.	Connector RG 6/5	(cod. P00100109)	n.9
13.	Carbuross O2 plug	(cod. P07900079)	n.4
14.	Extension MF1/8	(cod. P02900029)	n.1
15.	Connector RG 6/8	(cod. P00100029)	n.4
16.	Inlet Connector N2O	(cod. M57000809)	n.2
17.	Reducer F1/4 M1/8	(cod. P04800039)	n.5
18.	Non -return valve 1/8	(cod. P16000029)	n.6
19.	Triple connector RG 6/8	(cod. P00100139)	n.4
20.	O2 Inlet connector	(cod. M57000609)	n.2
21.	Air Inlet connector	(cod. M57000709)	n.1
22.	Cap hex screw ¼	(cod. P09900099)	n.2
23.	Distributor 8 way	(cod. P04500059)	n.1
24.	Cap M5	cod. P09900179)	n.2
25.	Nipples 1/8	(cod. P04700009)	n.1
26.	Modified Non return valve 1/8	(cod. P16000059)	n.1
27.	Connector RT 6/8	(cod. P00200069)	n.1
28.	Connector RD 6/8	(cod. P00000049)	n.7
29.	Back panel AM 5000	(cod. M55677529)	n.1
30.	Valve pneumatic 5 way	(cod. P10000089)	n.1
32.	Servocontrol 1/8 M5 SMC	(cod. P09900179)	n.2
33.	Lower flowmeter panel AM5000	(cod. M55682809)	n.1
34.	Pressure regulator AR 1000-M5	(cod. P20000039)	n.2
35.	Safety valve 1/8 spring 2	(cod. P17000009)	n.1
36.	O ₂ flowmeter 0-12 l/min	(cod. P50200009)	n.1
37.	N ₂ O flowmeter 0-12 l/min	(cod. P51200009)	n.1
38.	AIR flowmeter 0-12 l/min	(cod. P52200009)	n.1
39.	Regulator 25% flowmeter box	(cod. M58050309)	n.1
40.	Regulator flowmeter box.	(cod. M58050209)	n.3
41.	N ₂ O gear flowmeter box.	(cod. M54270709)	n.1
42.	Gear 25% O ₂ flowmeter box	(cod. M54270809)	n.1
43.	Plastic whistle	(cod. M23290009)	n.1
44.	Connector F1/8 F1/8	(cod. P04000019)	n.5
45.	Connector L1/8 MF	(cod. P04100089)	n.1
46.	O ₂ flowmeter 0-1 l/m	(cod. P50000009)	n.1
47.	N ₂ O flowmeter 0-1 l/m	(cod. P51000019)	n.1