



LIQUID COOLED SOLID STATE STARTER

OPERATION

Supersedes: 160.00-O2 (611)

Form 160.00-O2 (419)

MODELS SSS 7L-B, 14L-B, 26L-B, 33L-B 7LK-B, 14LK-B, 26LK-B, 33LK-B (STYLE B)

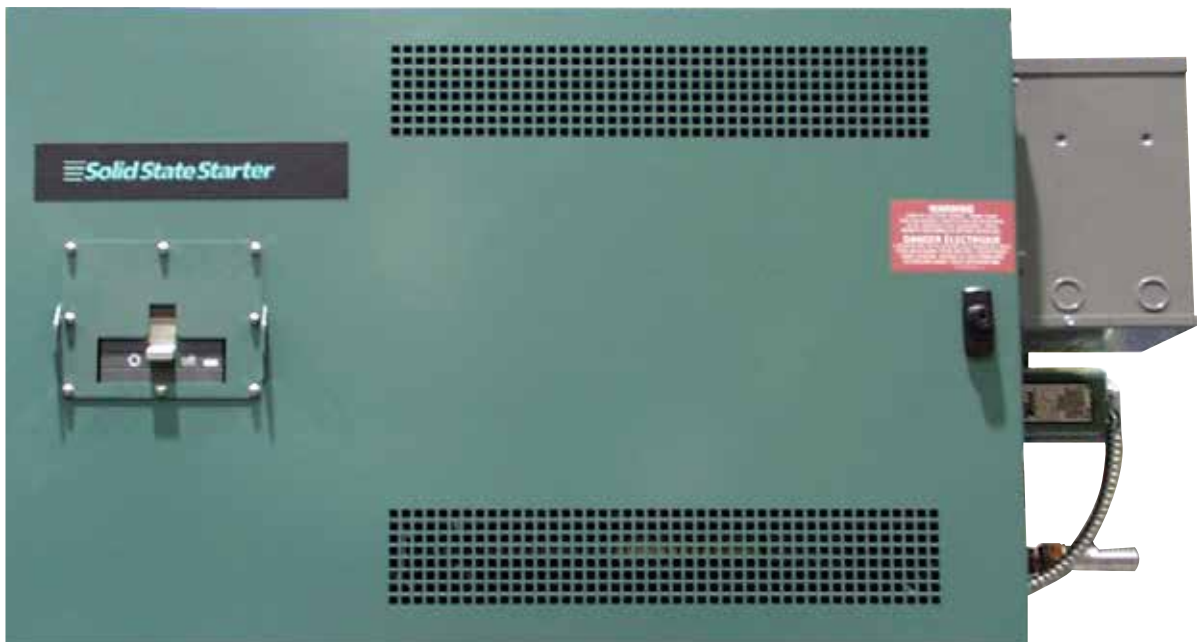

NOTE

Unless otherwise noted, information in this instruction is applicable to all style starters of the same size.

Example: 26L-B and 26LK-B

Issue Date:
April 30, 2019



IMPORTANT!

READ BEFORE PROCEEDING!

GENERAL SAFETY GUIDELINES

This equipment is a relatively complicated apparatus. During rigging, installation, operation, maintenance, or service, individuals may be exposed to certain components or conditions including, but not limited to: heavy objects, refrigerants, materials under pressure, rotating components, and both high and low voltage. Each of these items has the potential, if misused or handled improperly, to cause bodily injury or death. It is the obligation and responsibility of rigging, installation, and operating/service personnel to identify and recognize these inherent hazards, protect themselves, and proceed safely in completing their tasks. Failure to comply with any of these requirements could result in serious damage to the equipment and the property in

which it is situated, as well as severe personal injury or death to themselves and people at the site.

This document is intended for use by owner-authorized rigging, installation, and operating/service personnel. It is expected that these individuals possess independent training that will enable them to perform their assigned tasks properly and safely. It is essential that, prior to performing any task on this equipment, this individual shall have read and understood the on-product labels, this document and any referenced materials. This individual shall also be familiar with and comply with all applicable industry and governmental standards and regulations pertaining to the task in question.

SAFETY SYMBOLS

The following symbols are used in this document to alert the reader to specific situations:



Indicates a possible hazardous situation which will result in death or serious injury if proper care is not taken.



Identifies a hazard which could lead to damage to the machine, damage to other equipment and/or environmental pollution if proper care is not taken or instructions are not followed.



Indicates a potentially hazardous situation which will result in possible injuries or damage to equipment if proper care is not taken.

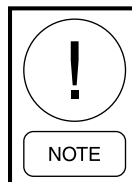

Highlights additional information useful to the technician in completing the work being performed properly.



External wiring, unless specified as an optional connection in the manufacturer's product line, is not to be connected inside the OptiView cabinet. Devices such as relays, switches, transducers and controls and any external wiring must not be installed inside the micro panel. All wiring must be in accordance with Johnson Controls' published specifications and must be performed only by a qualified electrician. Johnson Controls will NOT be responsible for damage/problems resulting from improper connections to the controls or application of improper control signals. Failure to follow this warning will void the manufacturer's warranty and cause serious damage to property or personal injury.

CHANGEABILITY OF THIS DOCUMENT

In complying with Johnson Controls' policy for continuous product improvement, the information contained in this document is subject to change without notice. Johnson Controls makes no commitment to update or provide current information automatically to the manual or product owner. Updated manuals, if applicable, can be obtained by contacting the nearest Johnson Controls Service office or accessing the Johnson Controls QuickLIT website at <http://cgproducts.johnsoncontrols.com>.

It is the responsibility of rigging, lifting, and operating/service personnel to verify the applicability of these documents to the equipment. If there is any question

regarding the applicability of these documents, rigging, lifting, and operating/service personnel should verify whether the equipment has been modified and if current literature is available from the owner of the equipment prior to performing any work on the chiller.

CHANGE BARS

Revisions made to this document are indicated with a line along the left or right hand column in the area the revision was made. These revisions are to technical information and any other changes in spelling, grammar or formatting are not included.

ASSOCIATED LITERATURE

MANUAL DESCRIPTION	FORM NUMBER
Operation (Unit) - Model YT, Style G or Later (Centrifugal)	160.55-O1
Operation (Unit) - Model YK, Style E or Later (Centrifugal)	160.54-O1
Operation (Unit) - Model YS, Style E or Later (Screw Chiller)	160.80-NOM1
Operation (Unit) - Model YR, Style A or Later (Screw Chiller)	160.81-O1
Operation (OptiView Control Center) - Model YT, Style G or Later (Centrifugal)	160.55-O1
Operation (OptiView Control Center) - Model YK, Style E or Later (Centrifugal)	160.54-O1
Operation (OptiView Control Center) - Model YS, Style E or Later (Screw Chiller)	160.80-O1
Operation (OptiView Control Center) - Model YR, Style A or Later (Screw Chiller)	160.81-O1
Service (OptiView Control Center) - Model YT, Style G or Later (Centrifugal)	160.55-M1
Service (OptiView Control Center) - Model YK, Style E or Later (Centrifugal)	160.54-M1
Service (OptiView Control Center) - Model YS, Style E or Later (Screw Chiller)	160.80-M1
Service (OptiView Control Center) - Model YR, Style A or Later (Screw Chiller)	160.81-M1
Wiring Diagram (OptiView Control Center) - Model Style G or Later (Centrifugal)	160.55-PW2
Wiring Diagram (OptiView Control Center) - Model YK, Style E or Later (Centrifugal)	160.54-PW8
Wiring Diagram (OptiView Control Center) - Model YS, Style E or Later (Screw Chiller)	160.80-PW2
Wiring Field Connections (Solid State Starter) - Model YT, Style G or Later (Centrifugal)	160.55-PW5
Wiring Field Connections (Solid State Starter) - Model YK, Style E or Later (Centrifugal)	160.54-PW5
Wiring Field Connections (Solid State Starter) - Model YS, Style E or Later (Screw Chiller)	160.80-PW4
Replacement Parts List (Solid State Starter)	160.00-RP3

THIS PAGE INTENTIONALLY LEFT BLANK

TABLE OF CONTENTS

SECTION 1 – THEORY OF OPERATION.....	9
Style B Liquid Cooled Solid State Starter Overview.....	9
General.....	11
System Microprocessors.....	11
Solid State Starter Cooling Loop.....	13
Electrical Conditions.....	14
Motor Protection.....	14
SECTION 2 – SYSTEM ARCHITECTURE	15
SECTION 3 – LOGIC/TRIGGER BOARD.....	17
General Information.....	17
Current Scaling.....	17
Logic/Trigger Board Indicator LEDs	18
Relay Functions.....	18
SECTION 4 – SAFETY SHUTDOWNS.....	21
General Information.....	21
105% Motor Current Overload	21
High Temperature.....	21
High Instantaneous Current	21
Open SCR.....	22
Output Current Imbalance.....	22
Phase Rotation.....	22
Shorted SCR.....	23
SECTION 5 – CYCLING SHUTDOWNS.....	25
General Information.....	25
High Supply Line Voltage	25
Initialization Failed.....	25
Invalid Current Scale.....	26
Logic Board Power Supply.....	26
Logic Board Processor.....	26
Low Phase Temperature.....	26
Low Supply Line Voltage.....	26
Phase Locked Loop.....	27
Phase Loss.....	27
Power Fault	28
Run Signal.....	28
Serial Communications	28
Stop Contacts Open	29
SECTION 6 – START INHIBIT.....	31
High Temperature.....	31
SECTION 7 – START-UP INSTRUCTIONS.....	33
Start-Up Checklist	33
Fill Cooling Loop	33

TABLE OF CONTENTS (CONT'D)

SECTION 8 – MAINTENANCE AND TROUBLESHOOTING.....	35
Manually Running The Closed Loop Coolant Pump	35
Coolant Maintenance	35
Troubleshooting The Closed Loop Coolant Pump.....	35
Troubleshooting Processes	35
Verify Shorted SCR	36
Verify Open or Shorted SCR Gate	36
Verify Gate Driver Output	36
Verify Real Phase Current Imbalance	37
Verify False Phase Current Imbalance.....	38
Removing SCR Assemblies	38
Installing SCR Assemblies	39

LIST OF FIGURES

FIGURE 1 - LCSSS – Front View, Exterior	9
FIGURE 2 - LCSSS – Basic Block Diagram	11
FIGURE 3 - LCSSS – Rear View, Exterior	12
FIGURE 4 - LCSSS – Interior, Connection Section - Fuses And Logic/Trigger Board	15
FIGURE 5 - LCSSS – Interior, Power Section	16
FIGURE 6 - LCSSS – Logic/Trigger Board Detail	18
FIGURE 7 - Logic/Trigger Board Pin Location Diagram	20
FIGURE 8 - Current Imbalance Due To Voltage Imbalance	37
FIGURE 9 - LCSSS – Power Components.....	39

LIST OF TABLES

TABLE 1 - Style B LCSSS Variations	10
TABLE 2 - CT Ratio	17
TABLE 3 - Current Capability	17
TABLE 4 - Logic/Trigger Board Inputs And Outputs	19
TABLE 5 - High Supply Line Voltage	25
TABLE 6 - Low Supply Line Voltage	27
TABLE 7 - Phase Loss	28
TABLE 8 - LCSSS Thermistor Characteristics	32
TABLE 9 - Required Material.....	33

THIS PAGE INTENTIONALLY LEFT BLANK

SECTION 1 – THEORY OF OPERATION

STYLE B LIQUID COOLED SOLID STATE STARTER OVERVIEW

The Style B Liquid Cooled Solid State Starter (LCSSS) is a state of the art, soft start for YORK compressor motors. New features include a combined Logic/Trigger Board, improved data collection, better generator operation, and easier set-up. The Style B LCSSS is to be applied only to the YORK OptiView Control Center.

This instruction is a description of the operation, start-up and troubleshooting of the Style B YORK LCSSS. It should be read thoroughly before servicing this product. Due to the integration of the Solid State Starter with the YORK OptiView Control Center, an understanding of the OptiView Control Center is necessary. Therefore, this document should be used with the *ASSOCIATED LITERATURE* on Page 3.

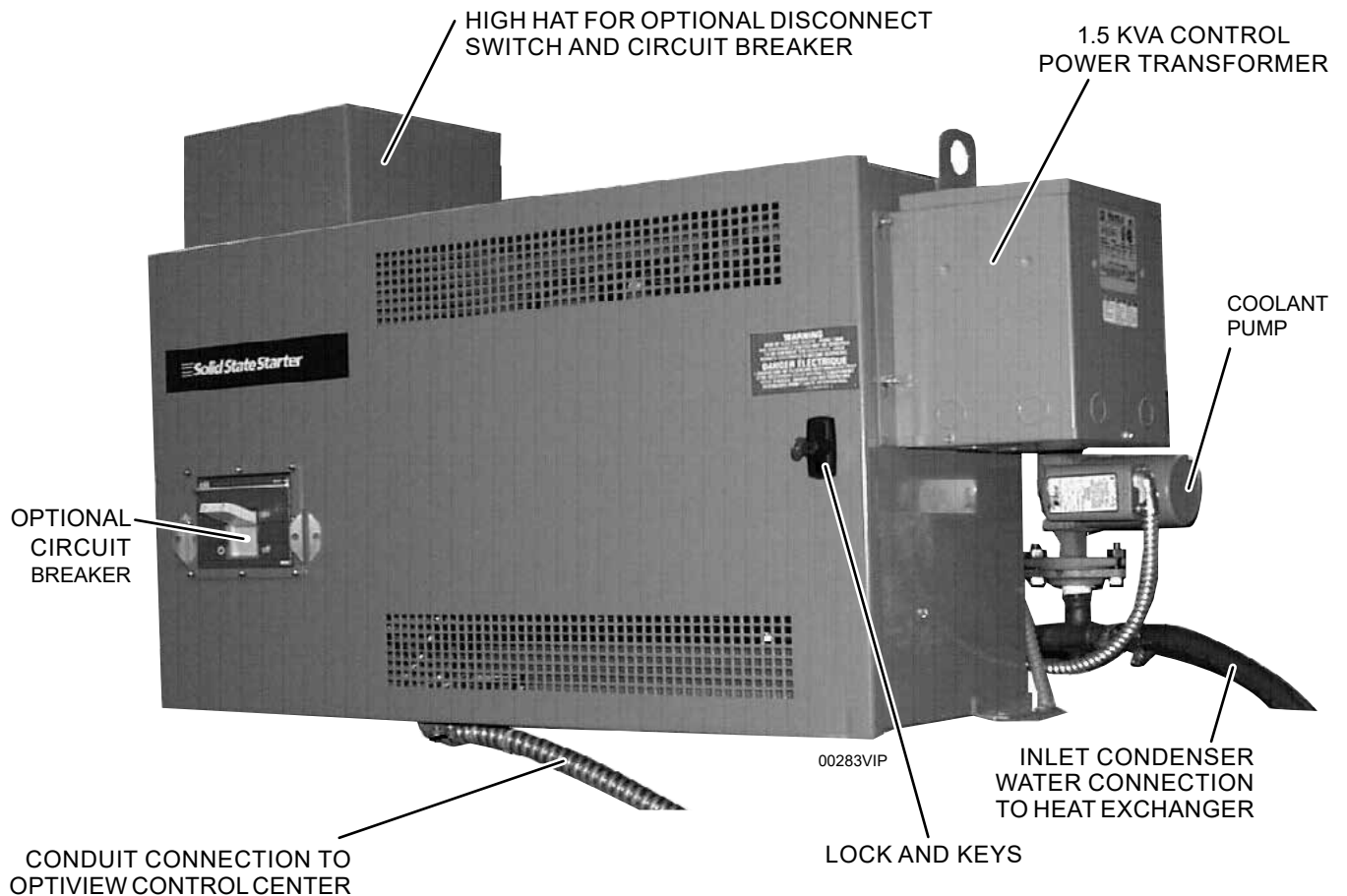

FIGURE 1 - LCSSS – FRONT VIEW, EXTERIOR

TABLE 1 - STYLE B LCSSS VARIATIONS

MODEL	LINE VOLTAGE APPLICATION (VAC)	PART NUMBER FOR A STARTER WITH LUG KIT
7L-40	380	371-02506-102
7L-46	440 / 460 / 480	371-02506-103
7L-58	550 / 575 / 600	371-02506-104
7L-50	380 / 400 / 415 50Hz	371-02506-105
14L-17	200 / 208	371-02506-106
14L-28	220 / 230 / 240	371-02506-107
14L-40	380	371-02506-108
14L-46	440 / 460 / 480	371-02506-109
14L-58	550 / 575 / 600	371-02506-110
14L-50	380 / 400 / 415 50Hz	371-02506-111
26L-17	200 / 208	371-02507-102
26L-28	220 / 230 / 240	371-02507-103
26L-46	440 / 460 / 480	371-02507-104
26L-40	380	371-02507-105
26L-58	550 / 575 / 600	371-02507-106
26L-50	380 / 400 / 415 50Hz	371-02507-107
33L-17	200 / 208	371-02507-108
33L-28	220 / 230 / 240	371-02507-109
33L-40	380	371-02507-110
33L-46	440 / 460 / 480	371-02507-111
33L-50	380 / 400 / 415 50Hz	371-02507-112

The New Style B LCSSS is also available with a disconnect switch or a circuit breaker. Consult the sales information for additional part numbers for those models.

GENERAL

The Style B LCSSS provides a soft continuous-current start for the compressor motor. During the starting sequence, the inrush motor current is limited to the programmed value of the starting current, by reducing the voltage applied to the motor. This reduction in voltage is accomplished when the silicon controlled rectifiers (SCRs) are turning on in a “phase-back” technique during motor acceleration. The trigger portion of the Logic/Trigger Board provides the firing (Turn-ON) pulses to the SCRs based upon a control voltage (VCON or Delay angle) provided by the Logic portion of the Logic/Trigger Board located in the Solid State Starter cabinet. After the motor has accelerated to synchronous speed, the SCRs are turned full on to conduct the full AC line voltage to the motor.

The Logic/Trigger Board provides safety functions to protect the compressor motor and the starter from many different conditions, such as high and low AC line voltage problems, high motor current, and possible SCR failure.

In order to reduce size of the starter, the cooling to the SCR assemblies is provided by a water-to-water heat exchanger between the chiller condenser water loop and the coolant in the closed loop. The heat exchanger length has been reduced and is now mounted on the starter itself. To reduce the length of the heat exchanger, the diameter of the tube has been increased.

SYSTEM MICROPROCESSORS

The system microprocessors have back-up protection in case they fail to function. A watch dog circuit is used, in which, the system microprocessor will strobe an output at a regular time interval. If the output strobe is missing, the Logic/Trigger Board will safely shut down the chiller. Another back-up circuit requires that the LCSSS receive a hardware and software signal from the OptiView Control Center, for the chiller to be started. If the two signals are not received within a certain period of time, a shutdown will occur.

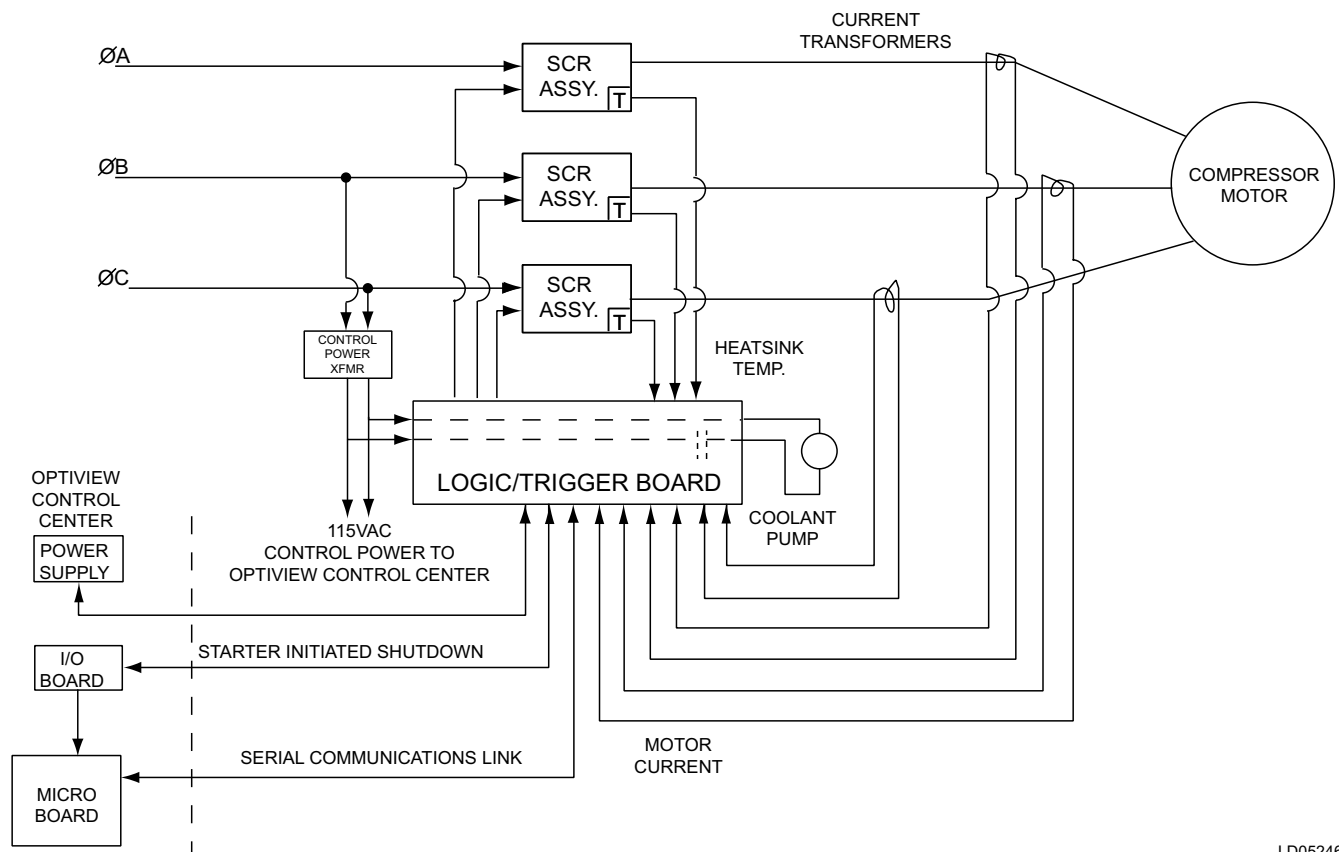

FIGURE 2 - LCSSS – BASIC BLOCK DIAGRAM

LD05246

The main system microprocessor performs many functions. It provides the serial communications link between the Logic/Trigger Board, and the Micro Board in the OptiView Control Center. It determines the proper current scaling for the size of starter, and interrogates the RUN/STOP signal from the OptiView Control Center. This processor also interrogates feedback signals to determine Open and Shorted SCR, Phase Loss, Phase Rotation, Motor Overload, High Instantaneous Current, High Line Voltage, and Low Line Voltage shutdowns.

The VCON signal is generated by the main system microprocessor. It is a digital signal placed on the data bus. This processor compares the starting current value, programmed at the OptiView Control Center, with the current feedback from the three output current transformers. A new value of VCON is generated every line cycle. This signal is then sent to the programmable logic device (PLD). The PLD determines the proper firing order for the SCRs to maintain the programmed starting current value. As the speed of the motor approaches synchronous speed output current drops off, the VCON value increases, and the PLD turns the SCRs full on. The output of the PLD is sent

to a digital driver chip and then to six optical couplers, one for each SCR.

The optical couplers are the first stage of the trigger portion of the Logic/Trigger Board. They isolate the high power circuit from the low power circuit. The power for the high power circuit is supplied from the J5 connector. The trigger section is made up of six output drivers, one for each SCR. Each output driver has a dedicated transformer, that steps down the incoming voltage, and provides isolation between each output driver.

A digital signal processor (DSP) is used for many timing and calculation functions. Root Mean Square (RMS) calculations require that input line voltage and output current values be calculated on a cycle-by-cycle basis. These calculations are used to display the RMS voltage and current for each phase, kW, and kWh on the OptiView Control Center. The DSP is also used to interpret the feedback signals from the thermistors mounted on the SCR's assemblies. All of these values are placed on the data bus for the main system microprocessor to generate faults, if required, and to send data on to the OptiView Control Center via the serial communication link.

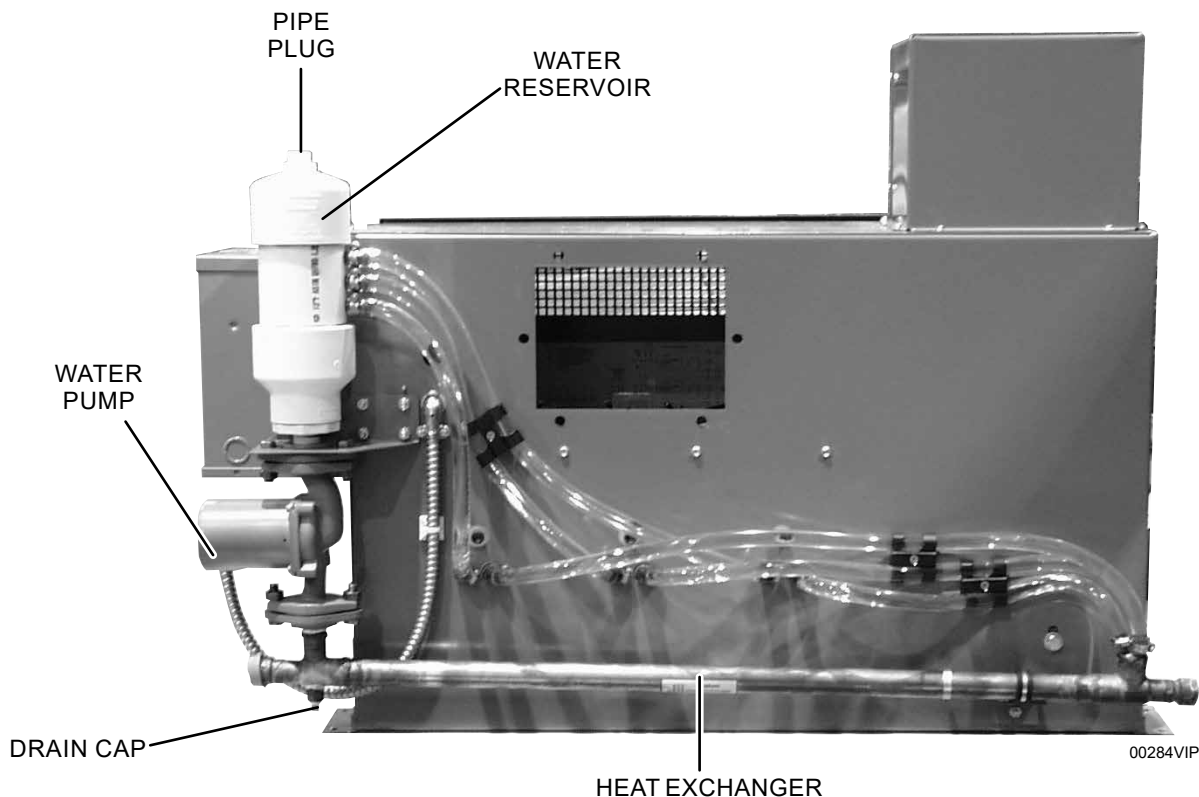

FIGURE 3 - LCSSS – REAR VIEW, EXTERIOR

SOLID STATE STARTER COOLING LOOP

The SCRs in the LCSSS generate heat during normal running conditions and become very hot during start-up of the chiller. This heat is generated by the fact that all of the current flowing to the motor is conducted through the SCRs. The SCRs are very reliable, but they do have a slight resistance value when they are turned on. The resistance, along with the load current of the motor, generates the heat.

The heat must be dissipated, or the SCRs will fail from an overheating condition. Two methods are commonly used to dissipate the heat. The first method, which was employed on older solid state starters was forced air cooling. This method works well, but requires a larger cabinet and the addition of many fans. The second method for dissipating the heat is to employ a water cooling system similar to that used in automobiles.

The cooling system for the LCSSS is different from the system in an automobile. In automobiles, heat is transferred to the air, but the starter transfers heat to the condenser water.

Condenser water is used to cool the starter for many reasons. One, the condenser water will always be available since it is part of the chiller system. The cooling is free since the condenser water will be cooled in the cooling towers for the chiller needs, and does not add any load to the chiller. If the chilled water was used to cool the starter, this would add to the chiller load and add cost to the customer. In a few applications where chilled water is being used because of extremely high condenser water pressure, a temperature regulating valve must be used. The temperature regulating valve should be set to 85°F so that condensation does not occur inside the starter cabinet. Using condenser water eliminates the concern for condensation occurring inside of the starter cabinet, which could damage the starter. The reliability of the starter is improved from the standpoint that the three forced air fans are replaced with one circulating pump.

The SCR assemblies are cooled by a pump circulating coolant in a closed loop through the SCR's heatsink and the outer tube of the tube-in-tube heat exchanger. When the coolant passes through the heatsink, it absorbs heat from the heatsink. As the coolant passes through the heat exchanger, it gives up its heat to the system condenser water that is flowing through the inner tube of the tube-in-tube heat exchanger. The design of the heat exchanger prevents the closed loop coolant from mixing with the condenser water. The condenser

water is forced through the heat exchanger by the pressure differential across the condenser shell input and output.



The cooling loop is filled with coolant at system start-up commissioning by the service technician. Refer to start-up instructions. As maintenance, the coolant must be changed every year. If the coolant is not replaced within this time interval, a potential for corrosion of the SCR's heatsink is greatly increased.

The Logic/Trigger Board constantly monitors the temperature of the three SCR heatsink assemblies with a thermistor attached to each assembly. The temperature of each thermistor is sent to the Micro Board in the OptiView Control Center via the serial communications link. Refer to ASSOCIATED LITERATURE on page 3 for details on where this data can be viewed on the OptiView Control Center.

If the temperature of any assembly exceeds a high value during a running condition, the Logic/Trigger Board will initiate a shutdown. Further, anytime the temperature of any assembly exceeds a high value and the starter is not running, the chiller will be prevented from starting and the closed loop coolant pump will be operated until the temperature has fallen. Also, if the temperature of any assembly falls below a preset value, the Logic/Trigger Board will initiate a shutdown.

Changes have been made to the OptiView Control Center software to improve the restart time of the starter. These changes allow for the control of the condenser water pump when a style 'B' LCSSS is used with the following OptiView Control Center software. On a YK chiller, the software is C.MLM.01.04 or later. On a YT chiller, the software is C.MLM.02.01 or later. On a YS chiller, the software is C.MLM.03.01 or later.

The condenser water pump will be turned on any time the chiller is started, and will continue to run until coastdown is complete. After coastdown is completed, the condenser water pump will continue to run if any one of the three thermistors indicated that the SCR assemblies are too hot. Once the temperature has fallen to a specified level, the condenser water pump will turn off.

This new control will cool down the SCR assemblies more quickly after the chiller has been stopped. Then the LCSSS can be started sooner, as long as the anti-recycle timer has been satisfied.

ELECTRICAL CONDITIONS

Proper starter operation requires that all phases of the AC power line voltage are present, and in the correct rotation. A “Power Fault” circuit provides protection from rapid power line current interruptions and transient switching. The AC power line voltage also must be relatively free of spikes and noise. If these conditions are not met, safety circuitry on the Logic/Trigger Board will cause a shutdown of the LCSSS. These shutdowns will protect the chiller from rotating in the wrong direction, or causing transient torque conditions on the compressor shaft. As well, the LCSSS will shut down and protect itself and the compressor motor if the AC power line voltage is too high or too low.

If the LCSSS is intended to be used on a generator application, then the JP1 jumper on the Logic/Trigger Board may need to be cut. Even if the starter will be connected to a generator for emergency power, the JP1 jumper may need to be cut. The JP1 jumper changes how the Logic/Trigger Board will track the frequency of the incoming line voltage. (See *Figure 6 on page 18* for location of JP1.) If the Logic/Trigger Board is a Rev. C, then the JP1 jumper must be cut for generator operation. If the Logic/Trigger Board is a Rev. D or later, the JP1 jumper has been removed, and the Logic/Trigger Board will function properly regardless of whether the starter is connected to the utility or generator power.

MOTOR PROTECTION

Compressor motor protection circuits are provided on the Logic/Trigger Board. These circuits protect the motor from continuous or instantaneous high current levels. Another circuit is used to determine if the current transformers are connected to the Logic/Trigger Board. This ensures that the LCSSS has current feedback before the chiller is started. Without the current feedback, the inrush current cannot be regulated. Also, if the output current becomes imbalanced due to AC power line voltage instability, or faulty SCR, a shutdown will occur. Other circuits are employed to sense a signal phase condition to the motor, or if one of the SCRs is open.

The coolant temperature inside any JCI-supplied liquid-cooled motor starter must be maintained above the dewpoint temperature in the equipment room to prevent condensing water vapor inside the starter cabinet. Therefore, an additional temperature-controlled throttle valve is needed in the flow path for the starter heat exchanger to regulate cooling above the equipment room dewpoint for applications using cooling sources other than evaporative air-exchange methods, such as wells, bodies of water, and chilled water. The temperature control valve should be the type to open on increasing drive coolant temperature, fail-closed, and set for a temperature above dewpoint. It can be requested as factory-supplied on a chiller order by special quotation.

SECTION 2 – SYSTEM ARCHITECTURE

The following LCSSS components are located in an enclosure mounted to the compressor motor terminal box. (Refer to *Figure 4 on page 15* and *Figure 5 on page 16*.)

- SCR Assemblies
- Current Transformers
- Logic/Trigger Board
- Control Circuit Fuses
- Oil Pump Motor Fuses
- Circuit Breaker or Disconnect Switch if used.

A control power transformer is attached to the side of the starter enclosure. This supplies 115 VAC control power to the starter and OptiView Control Center. The YK chiller uses a transformer which is different from that used on YT and YS chillers.

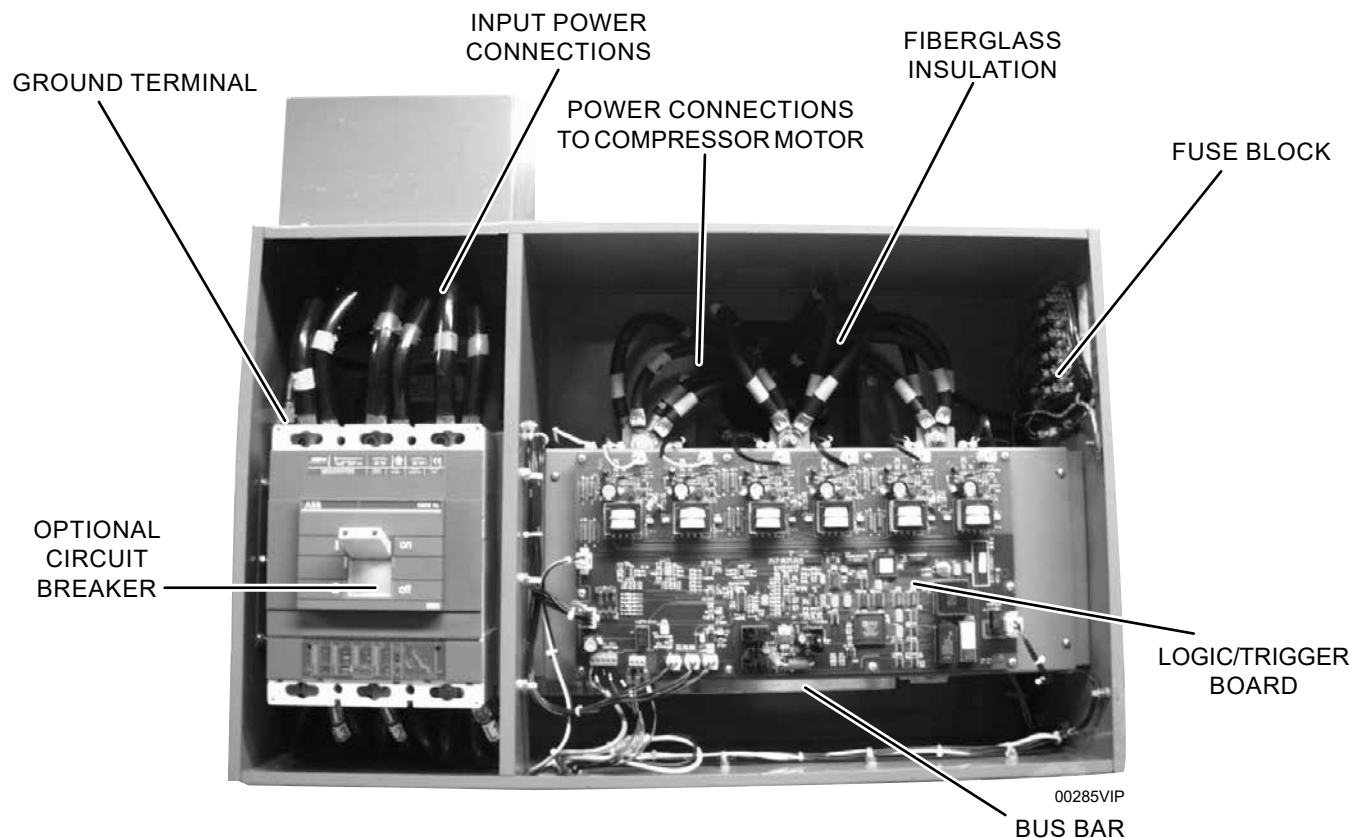

FIGURE 4 - LCSSS – INTERIOR, CONNECTION SECTION - FUSES AND LOGIC/TRIGGER BOARD

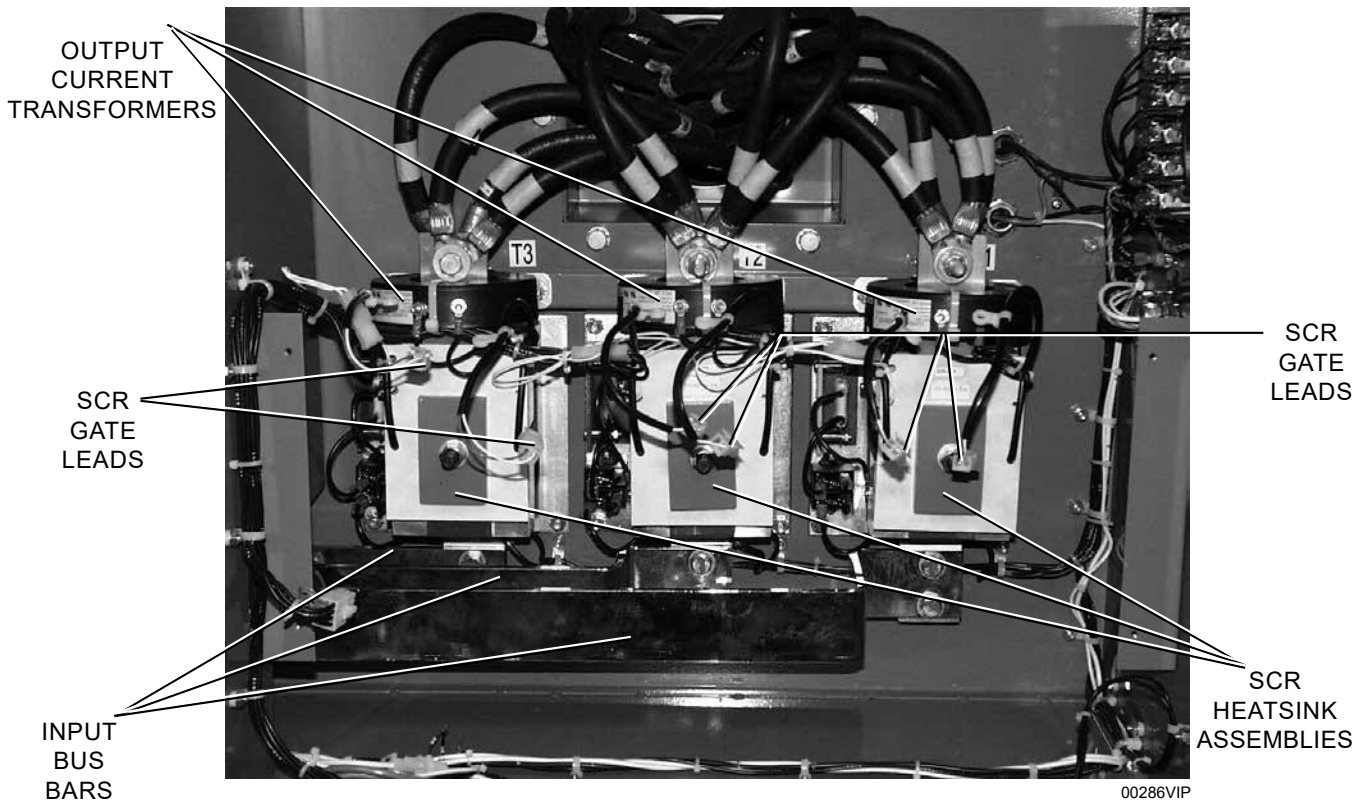

FIGURE 5 - LCSSS – INTERIOR, POWER SECTION

SECTION 3 – LOGIC/TRIGGER BOARD

GENERAL INFORMATION

The new Logic/Trigger Board is basically an integration of the functions in the Logic and Trigger Board in the Style A LCSSS. The new board uses a micro-processor, a digital signal processor, and a programmable logic device to duplicate the functions of the older analog boards. This new board is located in the LCSSS cabinet.

The Logic/Trigger Board communicates with the Micro Board in the OptiView Control Center via a serial communications link made up of a three-wire cable connected to TB1. The serial communications link is used to send all displayed data related to the starter, fault messages, and history data. This data is transmitted every 2 seconds, and then the data on the display of the OptiView Control Center is updated.

CURRENT SCALING

In order for the motor current to be properly scaled by the Micro Board, the Logic/Trigger Board sends a scaling code via the serial communications link to the Micro Board in the OptiView Control Center. The scaling code is determined by how jumpers are arranged on the J1 connector on the Logic/Trigger Board. Also, each model size of starter uses a different CT ratio. (See *Table 2 on page 17.*)

Since these jumpers are used to determine the size of the starter, a common Logic/Trigger Board can be used for 60 Hz applications. This will simplify the replacement of the Logic/Trigger Board. Each model has a different current capability, as outlined in *Table 3 on page 17.*

The motor FLA and the Starting Current are programmed on the OptiView Control Center. Refer to the *ASSOCIATED LITERATURE on Page 3* for details about which form is needed to program these values. Also, within these model classifications, there are various line voltage applications.

TABLE 2 - CT RATIO

MODEL SIZE	PINS JUMPERED TOGETHER ON J1	CT RATIO
7L	J1-7 TO J1-8, J1-8 TO J1-9, J1-9 TO J1-10	700:1
14L	J1-8 TO J1-10, J1-9 TO J1-10	1400:1
26L	J1-7 TO J1-10, J1-9 TO J1-10	2600:1
33L	J1-9 TO J1-10	3300:1

TABLE 3 - CURRENT CAPABILITY

LCSSS MODEL	MIN FLA	MAX FLA	MAX LRA	MIN START CURRENT	MAX START CURRENT	MAX DISPLAY AMPS
7L-40, 46, 58 and 50	35	260	1556	310	700	1163
14L-17, 28,40, 46, 58 and 50	65	510	3111	620	1400	2326
26L-17, 28, 40, 46, 58 and 50	125	850	5780	1150	2600	4319
33L-17, 28, 40, 46, and 50	215	1050	7335	1460	3300	5482

LOGIC/TRIGGER BOARD INDICATOR LEDES

The Logic/Trigger Board contains only two LEDs. Since all of the shutdown messages are displayed on the OptiView Control Center, there is no need for LEDs to annunciate a shutdown condition. The two LEDs are used to verify that the serial communications link is working.

CR6 is the Receive LED. This LED will flash green every 2 seconds to indicate that the Logic/Trigger Board has received data from the OptiView Control Center. (Refer to *Figure 6 on page 18* for location of LED.)

CR7 is the Transmit LED. This LED will flash red every 2 seconds to indicate that the Logic/Trigger Board has sent data to the OptiView Control Center. (Refer to *Figure 6 on page 18* for location of LED.)

RELAY FUNCTIONS

Relay K1 shall provide a hardware shutdown signal to the OptiView Control Center via wires 16 and 53. The relay will provide a normally open set of contacts that are driven closed when the LCSSS is operating satis-

factorily, and the contacts will open when the LCSSS initiates a Cycling or Safety shutdown. These contacts will remain open until the cause of the shutdown has been rectified.

Relay K2 controls the operation of the closed loop coolant pump. When the Micro Board commands the LCSSS to run, the main system microprocessor, via an output driver, causes the K2 relay contacts to close. As long as the K2 contacts are closed, the closed loop coolant pump will run. When the Micro Board commands the LCSSS to stop, the main system microprocessor, via an output driver, causes the K2 relay contacts to open (provided all of the thermistor temperatures are below 110°F). This will stop the closed loop coolant pump. Therefore, the closed loop coolant pump may start and stop with the compressor motor. Also, the K2 relay will be energized by the main system microprocessor when any heatsink temperature exceeds 110°F regardless of whether the chiller is running or not. When the temperature falls below 110°F, the main system microprocessor will de-energize K2 relay causing the pump to stop.

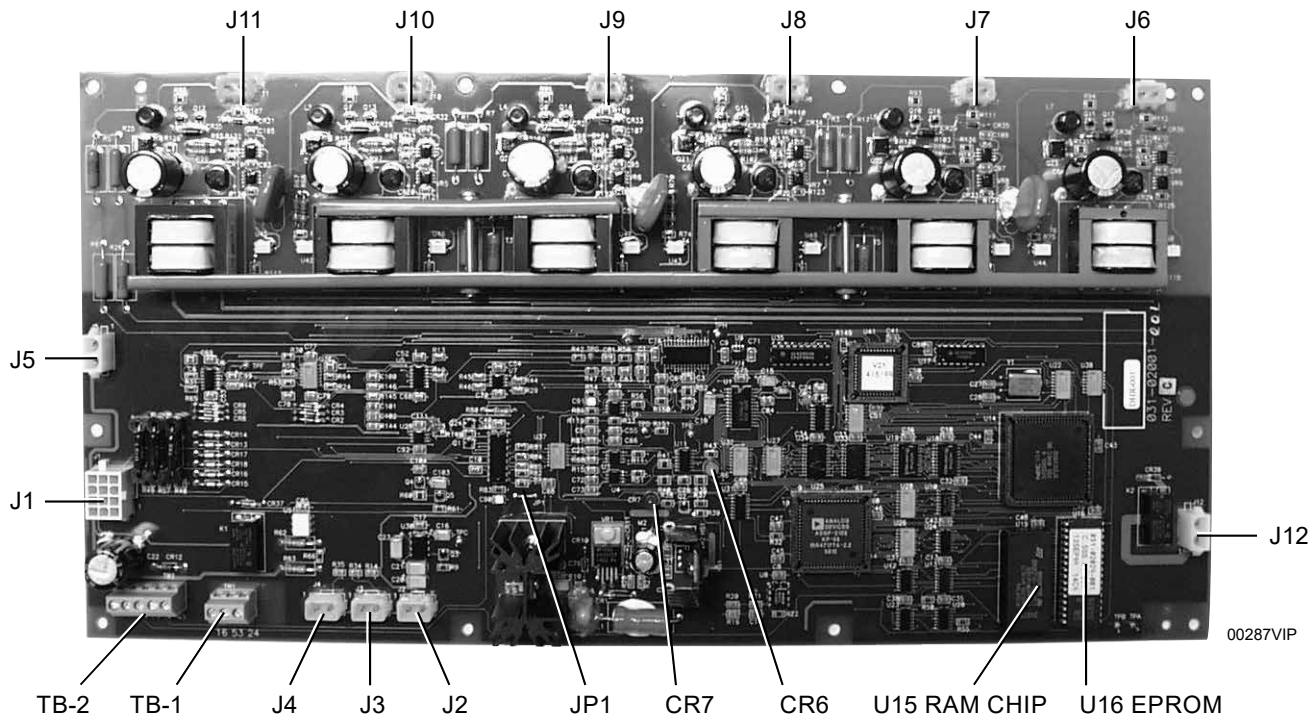

FIGURE 6 - LCSSS – LOGIC/TRIGGER BOARD DETAIL

TABLE 4 - LOGIC/TRIGGER BOARD INPUTS AND OUTPUTS

JUMPER	DESCRIPTION
J1 PINS	
J1-1 and 2	Phase "A" motor current input from current transformer (2T). AC voltage is read with digital voltmeter across resistor R76 (top of R76 is GND). Voltage read should be: $\text{RMS Motor Current} = \frac{\text{AC Voltage Measured}}{3.01} \times \text{CT RATIO}$ CT ratio = 700(7L), 1400(14L), 2600(26L), 3300(33L)
J1-3 and 4	Phase "B" motor current input from current transformer (3T). AC voltage is read across resistor R77 (top of R77 is GND). Refer to J1-1 and 2 to calculate current.
J1-5 and 6	Phase "C" motor current input from current transformer (4T). AC voltage is read across resistor R78 (top of R78 is GND). Refer to J1-1 and 2 to calculate current.
J1-7	Part of current scaling feedback, and determining the HP of the starter.
J1-8	Part of current scaling feedback, and determining the HP of the starter.
J1-9	Part of current scaling feedback, and determining the HP of the starter.
J1-10	Ground, used as part of the current scaling feedback.
J1-11	Part of current transformer connector interlock circuit.
J1-12	Part of current transformer connector interlock circuit.
J2 PINS	
J2-1	Phase "A" SCR assembly thermistor input. Refer to Table 6 for voltages and temperatures. (Utilize 10K ohm at 25°C thermistors.)
J2-2	See J2-1.
J3-PINS	
J3-1	Phase "B" SCR assembly thermistor input. See J2-1 voltage.
J3-2	See J3-1.
J4-PINS	
J4-1	Phase "C" SCR assembly thermistor input. See J2-1 for voltage.
J4-2	See J4-1.
J5-PINS	
J5-1	115VAC neutral input.
J5-2	115VAC from the secondary of the 1T.
J6-PINS	
J6-1	Phase "A" Positive SCR gate output. .55-2 VDC as measured to J6-2 when the starter is running.
J6-2	Phase "A" Positive SCR cathode. See J6-1.
J7-PINS	
J7-1	Phase "A" Negative SCR gate output. .55-2 VDC as measured to J7-2 when the starter is running.
J7-2	Phase "A" Negative SCR cathode. See J7-1.
J8-PINS	
J8-1	Phase "B" Positive SCR gate output. .55-2 VDC as measured to J8-2 when the starter is running.
J8-2	Phase "B" Positive SCR cathode. See J8-1.
J9-PINS	
J9-1	Phase "B" Negative SCR gate output. .55-2 VDC as measured to J9-2 when the starter is running.
J9-2	Phase "B" Negative SCR cathode. See J9-1.
J10-PINS	
J10-L	Phase "C" Positive SCR gate output. .55-2 VDC as measured to J10-2 when the starter is running.
J10-2	Phase "C" Positive SCR cathode. See J10-1.

TABLE 4 - LOGIC/TRIGGER BOARD INPUTS AND OUTPUTS

JUMPER	DESCRIPTION
J11-PINS	
J11-1	Phase "C" Negative SCR gate output. .55-2 VDC as measured to J11-2 when the starter is running.
J11-2	Phase "C" Negative SCR cathode. See J11-1.
J12-PINS	
J12-1	Switched 115 VAC to cooling loop water pump motor, 115 VAC when pump is commanded to run. 0 VAC when commanded to stop. Measured to J5-1.
J12-2	115 VAC as measured to J5-1.
TB1 PINS	
TB1-1, 16	Stop Contact between the LCSSS and the OptiView Control Center. Measure 115 VAC to J5-2 when no faults are active. Measure 0 VAC to J5-2 when faults are active.
TB1-2, 53	115 VAC supply voltage from the OptiView Control Center for the Stop Contact. Measure 115 VAC to J5-2 whenever power is applied.
TB1-3, 24	Run / Stop connections from the OptiView Control Center. Measure 115 VAC to J5-2 when in a run condition. Measure 0 VAC to J5-2 when in a stop condition.
TB2 PINS	
TB2-1	The transmit line for the Serial Communications Link from the Micro Board in the OptiView Control Center J15-1.
TB2-2	The receive line for the Serial Communications Link from the Micro Board in the OptiView Control Center J15-2.
TB2-3	The ground line for the Serial Communications Link from the Micro Board in the OptiView Control Center J15-3.
TB2-4	The 24 VDC power supply. Connected to J30 / P30 Pin 12. Refer to the <i>ASSOCIATED LITERATURE on Page 3</i> for the proper connection on the J2 connector of the power supply. Measure 24 VDC to TB2-5.
TB2-5	The ground connection for the power supply. Connected to J30 / P30 Pin 6, and J2 Pin 6 on the power supply inside the OptiView Control Center.

All measurements made to GND (J3-1) unless otherwise noted.

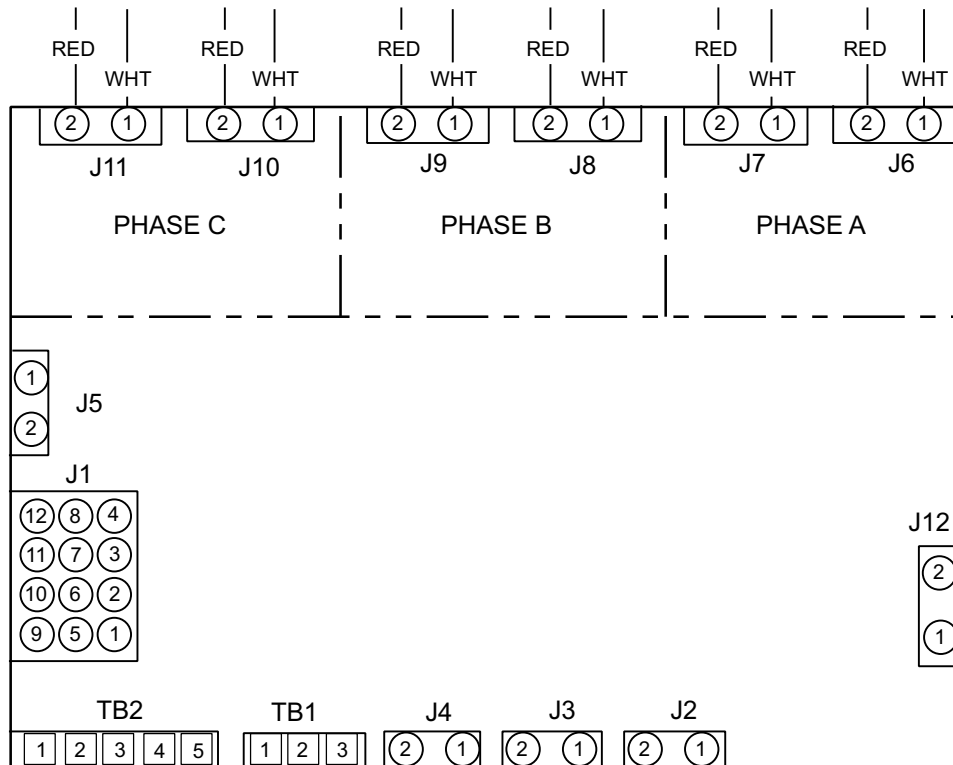

LD05282

FIGURE 7 - LOGIC/TRIGGER BOARD PIN LOCATION DIAGRAM

SECTION 4 – SAFETY SHUTDOWNS

GENERAL INFORMATION

Whenever a Safety Shutdown is generated by the Logic/Trigger Board a series of events will occur:

- If the chiller is running at the time of the shutdown, the Logic/Trigger Board will turn off the SCR gate outputs.
- If the chiller is running at the time of the shutdown, the OptiView Control Center will start a coastdown period (150 seconds for centrifugal chillers, or a 2 minute lockout for screw chillers).
- The K1 relay will de-energize causing an open circuit between TB1-1 wire #16 and TB1-2 wire #53. This action will indicate to the OptiView Control Center that the LCSSS has shutdown. The K1 relay will remain de-energized until the cause of the shutdown has been corrected.
- The Logic/Trigger Board will send a shutdown code via the serial communications link to the Micro Board in the OptiView Control Center. The Micro Board will interpret the shutdown code, and display a shutdown message on the display of the OptiView Control Center.

After the coastdown period has timed out, the chiller may be restarted, if the shutdown is no longer active. Place the Compressor Switch in the Stop/Reset position, and then into the Start position and release. The chiller will start if no faults are active.

105% MOTOR CURRENT OVERLOAD

The main system microprocessor receives from the OptiView Control Center a value of current that corresponds to 100% FLA. The Digital Signal Processor gathers the current information from the output CT's and converts this information to RMS current. The RMS current is sent to the main system microprocessor where the highest value of the three phase currents is compared with the 100% FLA times 1.05. When the highest value of current exceeds this threshold, a 40 second time is started. If this value of current is maintained for a period of 40 seconds a Safety shutdown will occur.

The shutdown message displayed will be “**LCSSS - 105% MOTOR CURRENT OVERLOAD**”.

Possible Problems

- Verify that the programmed FLA is correct on the OptiView Control Center.
- Verify that the output CT's are reading current correctly.
- Ensure that the output current is balanced.
- Verify that the pre-rotation vanes or slide valve are working properly.

HIGH TEMPERATURE

The starter contains three SCR assemblies. Each assembly has a temperature sensor mounted on the mass block in front of the SCR. The feedback from the temperature sensors is compared in the main system microprocessor against a shutdown threshold of 212°F. If any one of the three sensors exceeds the shutdown threshold, a Safety shutdown will occur. The coolant pump will continue to run until all temperatures are below 109°F.

The shutdown message displayed will be “**LCSSS – HIGH PHASE X HEATSINK TEMPERATURE - RUNNING**”, where X is either A, B or C, corresponding to SCR phase assemblies A, B or C respectively.

Possible Problems

- Ensure that the coolant level is proper.
- Verify that the coolant is pink or clear.
- Verify that the coolant pump is working.
- Verify that the heat exchanger is clean, and that there is condenser water flow.
- Ensure that the heatsink assembly is not clogged.

HIGH INSTANTANEOUS CURRENT

The RMS starting current is programmed on the OptiView Control Center to a value of 20 – 45% x Delta LRA (normal value is 45% delta LRA). The RMS starting current is converted to peak starting current times 115% to generate a shutdown threshold. If the motor current in any phase ever reaches this threshold and is maintained for one second, a Safety shutdown will occur. If the motor current reaches this threshold for less than one second, a shutdown will not occur.

The shutdown message displayed will be “**LCSSS - HIGH INSTANTANEOUS CURRENT**”.

Possible Problems

- Check for a shorted SCR.
- Disconnect the motor and test for shorts phase to ground, and phase to phase.
- If the shutdown occurs during the ramp up of the motor, an open SCR maybe the problem.
- Verify that the gate of the SCR is not open.
- Verify that the programmed starting current is correct on the OptiView Control Center.
- Verify that the output CT's are reading current correctly.
- Check for an open input fuse.

OPEN SCR

This shutdown becomes active after the first 40 seconds of starter operation. The main system microprocessor looks at the voltage across each SCR via an opto-coupler. When the SCR is turned on, the output of the opto-coupler is high, and when the SCR is turned off, the output of the opto-coupler is low. If this signal is low for 5 consecutive seconds, a Safety shutdown will occur.

To help eliminate nuisance trips, this shutdown can be disabled from the OptiView Control Center. Refer to the OptiView Control Center Service form for your style of chiller (refer to ASSOCIATED LITERATURE in this form, page 3, for the proper form number).

The shutdown message displayed will be “LCSSS - OPEN SCR”.

Possible Problems

- Verify operation of the gate drivers.
- Verify that the starting current value is correct.
- Ensure that the motor is not overloaded on start. This has been a problem on screw compressors.
- Verify that the motor is connected.
- Verify that the gate of the SCR is not open.
- Check for an open input fuse.

OUTPUT CURRENT IMBALANCE

This shutdown will become active after the starter has been running for 45 seconds, and when the highest of the three motor currents exceeds 80% of the programmed FLA. After these conditions are met, if any one phase of motor current exceeds 30% of the average current for 45 seconds, a Safety shutdown will occur. Review the following example.

If

current in the A phase = 200A
current in the B phase = 200A
current in the C phase = 118A

Then

$$I_{AVE} = \frac{200 + 200 + 118}{3}$$

$$I_{AVE} = 173A$$

$$I_{ACCEPTABLE} = 173 \times \pm 30\% = 121A, 225A$$

Therefore,

Since phase “C” current = 118A which is less than the acceptable 121A, the chiller would shut down if this imbalance exists for 45 seconds.

The shutdown message displayed will be “LCSSS – MOTOR OR STARTER-CURRENT IMBALANCE”.

Possible Problems

- Verify the input voltage to the starter.
- Verify that the output CT's are reading current correctly.
- Verify the gate drive on the Logic/Trigger Board.

PHASE ROTATION

The Logic/Trigger Board contains circuitry that generates a waveform for each of the input phase voltages. These waveforms are compared to each other by the main system microprocessor. When the “A” phase voltage transitions positive, the “C” phase voltage must be positive. Also, when the “A” phase voltage transitions negative, the “B” phase voltage must be positive. This shutdown is only active during the first 30 line cycles after power is applied to the starter. After the first 30 line cycles, the shutdown is no longer active.

The YR chiller has a “MOTOR – PHASE ROTATION” fault. This is not a fault of the LCSSS. This fault is caused when the motor is turning in the wrong direction. This fault is caused by the motor wiring between the LCSSS and the chiller motor being reversed.

The shutdown message displayed will be “**LCSSS - PHASE ROTATION**”.

Possible Problems

Verify the phasing of the input power wiring.

SHORTED SCR

This shutdown is active any time the starter is not running. Once this shutdown becomes active the main system microprocessor starts to evaluate the voltage across the SCRs via an opto-coupler. If the output of the opto-coupler is low (implying the SCR is turned on or shorted) for 5 continuous seconds, and the RMS phase volt-

age for that phase is approximately 90% of the selected input voltage range a Safety shutdown will occur. If no voltage range has been selected on the OptiView Control Center, than the voltage check will not be performed. To help eliminate nuisance trips, this shutdown can be disabled from the OptiView Control Center. Refer to the OptiView Control Center Service form for your style of chiller (refer to ASSOCIATED LITERATURE in this form, page 3, for the proper form number).

The shutdown message displayed will be “**LCSSS - PHASE X SHORTED SCR**”, where X is either A, B or C, corresponding to SCR phase assemblies A, B or C respectively.

Possible Problems

Verify if one of the SCRs are shorted.

THIS PAGE INTENTIONALLY LEFT BLANK

SECTION 5 – CYCLING SHUTDOWNS

GENERAL INFORMATION

Whenever a Cycling Shutdown is generated by the Logic/Trigger Board, a series of events will occur.

- If the chiller is running at the time of the shutdown, the Logic/Trigger Board will turn off the SCR gate outputs.
- If the chiller is running at the time of the shutdown, the OptiView Control Center will start a coastdown period (150 seconds for centrifugal chillers, or a 2 minute lockout for screw chillers).
- The K1 relay will de-energize causing an open circuit between TB-1-16 and TB-1-53. This action will indicate to the OptiView Control Center that the LCSSS has shutdown. The K1 relay will remain de-energized until the cause of the shutdown has been corrected.
- The Logic/Trigger Board will send a shutdown code via the serial communications link to the Micro Board in the OptiView Control Center. The Micro Board will interpret the shutdown code, and display a shutdown message on the display of the OptiView Control Center.

After the coastdown period has timed out, the chiller will automatically restart, if the shutdown is no longer active, and if the Compressor Switch is still in the Run position.

HIGH SUPPLY LINE VOLTAGE

The Logic/Trigger Board monitors the three phases of input voltage via the negative SCR cathode connection. The DSP will determine the phase to phase RMS voltage and send this information to the main system microprocessor. The main system microprocessor will compare these voltages to shutdown thresholds in the

chart below. If the input voltage exceeds the shutdown threshold for 20 continuous seconds, then a Cycling shutdown will occur. This shutdown is disabled for the first 20 seconds of the starter run, to prevent nuisance shutdowns from voltage spikes during start. The voltage range is programmed on the OptiView Control Center. If no voltage range is programmed, then this shutdown will be disabled. Refer to OptiView Control Center Service form for your style of chiller (refer to ASSOCIATED LITERATURE in this form, page 3, for the proper form number).

The shutdown message displayed will be **“LCSSS - HIGH SUPPLY LINE VOLTAGE”**.

Possible Problems

- Verify that the proper voltage range is selected on the OptiView Control Center.
- Verify proper line voltage is being applied to the starter.

INITIALIZATION FAILED

After power has been applied to the OptiView Control Center, the Micro Board attempts to communicate with the Logic/Trigger Board via the serial communication link. If the Micro Board has tried to communicate with the Logic/Trigger Board ten times, and the Logic/Trigger Board has not responded, a Cycling shutdown will occur. Even though the shutdown was recorded, the Micro Board will continue to try to communicate with the Logic/Trigger Board. Since the Micro Board attempts to communicate with the Logic/Trigger Board every two seconds, the shutdown will occur approximately 20 seconds after power was applied.

The shutdown message displayed will be **“LCSSS INITIALIZATION FAILED”**.

TABLE 5 - HIGH SUPPLY LINE VOLTAGE

VOLTAGE RANGE	HIGH SUPPLY LIMIT – STOPPED	HIGH SUPPLY LIMIT – RUNNING
Disabled	None	None
200 - 208	226	227
220 - 240	261	262
380	414	415
400	435	436
415	453	454
440 - 480	523	524
550 - 600	654	655

Possible Problems

- Verify the communication cable between the OptiView Control Center and the Logic/Trigger Board.
- If CR6 is blinking, but CR7 is not blinking, the Logic/Trigger Board has failed. If both CR6 and CR7 are blinking every two seconds continue to the next step
- If problem is still not detected, then perform the communication loop back test (ASSOCIATED LITERATURE listed on page 3 for OptiView Control Center Service).

INVALID CURRENT SCALE

To protect the motor and starter from high current conditions, and the chiller from Power Fault conditions, the current transformers must be properly connected to the Logic/Trigger Board. The current transformers are connected to the Logic/Trigger Board via the P1/J1 connector. This connection also determines starter HP size, and allows the use of only one Logic/Trigger Board. If P1 is not connected to J1, the three inputs to determine the starter size will be pulled high and a Cycling shutdown will occur. The presence of the P1/J1 connector is verified when power is applied to the starter. During the period that the connector is not connected to J1, the three phase currents and the KW values will be displayed as zero on the display of the OptiView Control Center.

Generally, this shutdown will occur during the start-up of the chiller.

The shutdown message displayed will be “**LCSSS - INVALID CURRENT SCALE SELECTION**”.

Possible Problems

- Verify that the J1 connector is installed on the Logic/Trigger Board.
- Verify the wiring of the J1 connector.

LOGIC BOARD POWER SUPPLY

Whenever power is applied to the LCSSS this shutdown is indicated.

The shutdown message displayed will be “**LCSSS - Logic Board Power Supply**”.

Possible Problems

Check for possible input power problems.

LOGIC BOARD PROCESSOR

A watchdog type of system is used to determine if the main system microprocessor and the DSP are still communicating. Normally, the main system microprocessor and the DSP communicate every 3 mSec. A watchdog counter is set-up in the main system microprocessor to a count of 80. If after 80 attempts to communicate between the main system microprocessor and the DSP, and the DSP still does not respond, a Cycling shutdown will occur. At the same point in time the DSP will be rebooted. The watchdog timer will only reset if communications have been established.

The shutdown message displayed will be “**LCSSS - LOGIC BOARD PROCESSOR**”.

Possible Problems

If the problem continues replace the Logic/Trigger Board.

LOW PHASE TEMPERATURE

The value of each thermistor mounted on the SCR assemblies is constantly compared to a shutdown threshold value of 37°F in the main system microprocessor. If any one of the three thermistors has a value that corresponds to 37°F or lower, a Cycling shutdown will occur. The thermistors are connected to the Logic/Trigger Board at plugs P2, P3, P4.

The shutdown message displayed will be “**LCSSS - LOW PHASE X TEMPERATURE SENSOR**”, where X is either A, B or C corresponding to SCR phase assemblies A, B or C respectively.

Possible Problems

- This problem is normally associated with a open thermistor.
- Verify that P2, P3, and P4 are connected to the Logic/Trigger Board.
- Verify the interconnection between the thermistor and the P2, P3, and P4 connectors.

LOW SUPPLY LINE VOLTAGE

The Logic/Trigger Board monitors the three phases of input voltage via the negative SCR cathode connection. The DSP determines the phase to phase RMS voltage and sends this information to the main system microprocessor. The main system microprocessor will compare these voltages to shutdown thresholds in Table 4. If the input voltage falls below the shutdown threshold for 20 continuous seconds, then a Cycling

shutdown will occur. This shutdown is disabled for the first 20 seconds of the starter run, to prevent nuisance shutdowns from heavily loaded transformers. The voltage range is programmed on the OptiView Control Center. If no voltage range is programmed, then this shutdown will be disabled (ASSOCIATED LITERATURE listed on Page 3).

The shutdown message displayed will be **“LCSSS - LOW SUPPLY LINE VOLTAGE”**.

Possible Problems

- Verify that the proper voltage range is selected on the OptiView Control Center.
- Verify proper line voltage is being applied to the starter.
- If the problem occurs during generator operation, add some standby load to the generator so that the generator can respond more quickly to load changes.

PHASE LOCKED LOOP

The cathode connection of the negative SCRs is connected to the 3-phase AC power line. This information is sent to the Logic/Trigger Board, where a circuit generates a waveform that is synchronized to the ‘A’ phase voltage. This waveform and the ‘A’ phase voltage are compared, and the deviation is used to generate an error signal. The error signal is then used to correct the waveform and maintain synchronization with the ‘A’ phase voltage. The synchronized waveform is used for the firing control of all the SCRs. If the error signal becomes too large then the synchronization with the ‘A’ phase voltage will be lost. If synchronization is not maintained, the SCRs will misfire and damage the chiller.

The shutdown message displayed will be **“LCSSS - PHASE LOCKED LOOP”**.

Possible Problems

- Although this circuit is very fast, storms or power problems can cause the frequency of the ‘A’ phase voltage to change too rapidly.
- If the problem occurs during generator operation, ensure that the JP1 jumper has been cut (on Rev C. or earlier Logic/Trigger Boards).
- If the problem occurs during generator operation, add some standby load to the generator so that the generator responds more quickly to load changes.

PHASE LOSS

The three phases of input line voltage are fed back to the Logic/Trigger Board via the cathode connections of the negative SCRs. The RMS voltage is then compared against a threshold value, that is 30% of the programmed input voltage range. For example, if the programmed input voltage range is 440-480 VAC, then the threshold value will be 132 VAC. If the voltage range is disabled in the OptiView Control Center then the shutdown value will be 30% of 200 VAC. Thus, the threshold value will be 60 VAC. Anytime one of the three phases of input line voltage drops below the threshold value, a Cycling shutdown will occur.

The shutdown message displayed will be **“LCSSS - PHASE LOSS”**.

TABLE 6 - LOW SUPPLY LINE VOLTAGE

VOLTAGE RANGE	HIGH SUPPLY LIMIT – STOPPED	HIGH SUPPLY LIMIT – RUNNING
Disabled	None	None
200 - 208	174	160
220 - 240	200	185
380	331	305
400	349	320
415	362	335
440 - 480	400	370
550 - 600	502	460

TABLE 7 - PHASE LOSS

INPUT VOLTAGE RANGE OF THE LCSSS	SHUTDOWN VALUE
Disabled	60VAC
200 - 208	60VAC
220 - 240	66VAC
380	114VAC
400	120VAC
415	125VAC
440 - 480	132VAC
550 - 600	165VAC

Possible Problems

- Many times this is a normal fault related to a storm or lightning.
- Verify the presence of all three phase of input voltage. An input fuse may be open.
- Verify that the proper voltage range is selected on the OptiView Control Center.

POWER FAULT

The Power Fault Detector prevents compressor damage due to a momentary interruption of motor current (transient torque condition). This shutdown is active after the first four seconds of a chiller start, and after all three phases of motor current have exceeded 25% of FLA for one second. Then, if any one phase of motor current drops below a threshold of 10% FLA for three line cycles, a Cycling shutdown will occur. To prevent nuisance shutdowns, this shutdown is disabled just before the chiller is placed into a coastdown condition.

The shutdown message displayed will be “LCSSS - POWER FAULT”.

Possible Problems

- Many times this is a normal fault related to a storm or lighting.
- Verify that the output CT's are reading current correctly.

RUN SIGNAL

To start the compressor motor, the OptiView Control Center sends a 115 VAC start signal to the Logic/Trigger Board. The start signal is applied between J5-2 wire #2, and TB1-3 wire #24 (hardware signal). This signal

is opto-coupled, and then sent to the main system microprocessor, where it is compared with a run signal sent from the OptiView Control Center via the serial communications link (software signal). When either of these two signals are received by the main system microprocessor, a 5 second timer is started. The timer stops when the second of the two signals is received by the main system microprocessor. If both of the signals are not received within 5 seconds, a Cycling shutdown will occur.

The shutdown message displayed will be “LCSSS - RUN SIGNAL”.

Possible Problems

- Verify that 115VAC is applied between J5-2 wire #2, and TB1-3 wire #24.
- Check for solder cracks around J5 and TB-1.
- Verify the serial communication link cable.

SERIAL COMMUNICATIONS

This shutdown becomes active after a successful completion of initialization. If the Micro Board has tried to communicate with the Logic/Trigger Board ten times, or if the Logic/Trigger Board does not receive a transmission from the Micro Board within 20 seconds, then a Cycling shutdown will occur. Since the Micro Board attempts to communicate with the Logic/Trigger Board every two seconds, the shutdown will occur in approximately 20 seconds. Under this condition, all information about the starter displayed on the OptiView Control Center will be zero.

The shutdown message displayed will be “LCSSS - SERIAL COMMUNICATIONS”.

Possible Problems

- Verify the communication cable between the OptiView Control Center and the Logic/Trigger Board.
- If CR6 is blinking, but CR7 is not blinking, the Logic/Trigger Board has failed. If both CR6 and CR7 are blinking every 2 seconds, continue to the next step.
- If problem is still not detected, then perform the communication loop back test (see *ASSOCIATED LITERATURE on Page 3* for OptiView Control Center Service).

STOP CONTACTS OPEN

Whenever a shutdown occurs, the K1 relay de-energizes and the contacts open on the Logic/Trigger Board. If the K1 contacts open, and no fault is detected in the serial communications link, then a Cycling shutdown will occur.

The shutdown message displayed will be “**LCSSS - STOP CONTACTS OPEN**”.

Possible Problems

- Verify that the J1 connector is installed on the Logic/Trigger Board, and that there is a wire installed between J1-11 and J1-12.
- Verify that TB1-1 and TB1-2 are properly wired.

- Verify the communication cable between the OptiView Control Center and the Logic/Trigger Board.
- Verify operation of the K1 relay. If the function of K1 is not working properly, replace the Logic/Trigger Board.
- If CR6 is blinking, but CR7 is not blinking, the Logic/Trigger Board has failed. If both CR6 and CR7 are blinking every two seconds, continue to the next step.
- If problem is still not detected, then perform the communication loop back test (ASSOCIATED LITERATURE listed on page 3 for OptiView Control Center Service).

THIS PAGE INTENTIONALLY LEFT BLANK

SECTION 6 – START INHIBIT

HIGH TEMPERATURE

During the ramp up period, when starting current is being conducted to the motor, the internal die of the SCR becomes very hot. Since the SCRs become very hot, they must be cooled before each start of the chiller or they will fail. To ensure that the SCRs are cooled before each start, a Start Inhibit threshold is used. This threshold is 110°F. Under normal running conditions of the LCSSS, the SCR temperature is typically greater than 110°F. So, when the chiller has completed a coastdown, it is normal for the Start Inhibit message of **“LCSSS - HIGH PHASE X HEATSINK TEMPERATURE – STOPPED”** to appear on the OptiView Control Center display. The X in the message will indicate which phase is above the threshold. The coolant pump will continue to run as long as the Start Inhibit is active. The Remote Ready Relay contacts will be open during this condition. When the temperature of all three phases has fallen below 109°F, the coolant pump will stop running and the LCSSS will now be able to start. Since the Start Inhibit is not a fault condition, no events are logged into the History Log.

To minimize the time it takes to cool down the SCRs, and allow the chiller to restart sooner if the anti-recycle has timed out, a condenser water pump control has been added to the OptiView Control Center software. This added feature is available only for Mod. ‘B’ starters with the following OptiView Control Center software. On a YK chiller, the software is C.MLM.01.04 or later. On a YT chiller, the software is C.MLM.02.01 or later. On a YS chiller, the software is C.MLM.03.01 or later.

This new condenser water pump control will continue to run the condenser water pump after the chiller has been placed into a coastdown, as long as the following conditions are met. If any one of the three SCR assemblies thermistors indicates a temperature of greater than 105°F, and if it has been less than one hour since the chiller was last stopped. The condenser water pump will also turn on, when power is restored after a power fault, if any one of the three SCR assemblies thermistors indicates a temperature of greater than 105°F, and it has been less than one hour since the chiller was last stopped or shutdown due to a safety or cycling shutdown. Once the temperature of all three thermistors is below 105°F, the condenser water pump will turn off, and will not turn on until the next compressor start.

TABLE 8 - LCSSS THERMISTOR CHARACTERISTICS

TEMP °F NOMINAL	TEMP °C NOMINAL	R-THERMISTOR IN OHMS*	V-THERMISTOR**	V-INPUT***
70	21.11	11882	3.44	1.06
75	23.89	10502	3.33	1.16
80	26.67	9299	3.21	1.26
85	29.44	8253	3.09	1.37
95	35.00	6530	2.84	1.59
105	40.56	5208	2.59	1.82
106	41.11	5094	2.57	1.84
107	41.67	4982	2.54	1.86
108	42.22	4874	2.52	1.89
109	42.78	4767	2.49	1.91
110	43.33	4664	2.47	1.93
111	43.89	4562	2.44	1.95
112	44.44	4465	2.42	1.98
113	45.0	4367	2.39	2.00
114	45.56	4274	2.37	2.02
115	46.11	4182	2.34	2.04
120	48.89	3757	2.22	2.15
130	54.44	3048	1.98	2.37
140	60.00	2487	1.75	2.57
150	65.56	2042	1.54	2.76
160	71.11	1687	1.35	2.93
170	76.67	1401	1.18	3.08
180	82.22	1170	1.03	3.22
190	87.78	981	0.90	3.34
200	93.33	827	0.78	3.44
207	97.22	736	0.71	3.51
208	97.78	724	0.698	3.52
209	98.33	713	0.688	3.53
210	98.88	701	0.679	3.53
211	99.44	690	0.669	3.54
212	100.00	678	0.660	3.55
213	100.56	667	0.651	3.56
214	101.11	657	0.642	3.567
215	101.67	646	0.633	3.575
216	102.22	636	0.624	3.583
217	102.77	626	0.616	3.591

This chart assumes a 5VDC supply.

* Resistance measured across J2, J3, and J4.

** Voltage measured across J2, J3, and J4.

*** Voltage measured from Pin J2-1 to Gnd., J3-1 to Gnd., and J4-1 to Gnd.

SECTION 7 – START-UP INSTRUCTIONS

START-UP CHECKLIST

- **IMPORTANT** - Remove all debris from the starter cabinet where AC powerline cables attach to starter bus bars. This includes nuts, bolts, washers, hand tools, test equipment, metal shavings etc. Motor starting current creates strong magnetic fields that can pull metal objects into the starter bus bars possibly causing short circuits, and damaging the Solid State Starter!!
- Drain and fill the SCR heatsink assembly cooling loop with coolant (refer to Fill Cooling Loop section).
- Connect wiring to the starter per the proper wiring diagram.
- If the LCSSS is intended for generator operation, and the Logic/Trigger Board is a Rev. C or earlier, the JP1 jumper must be cut. If the LCSSS is intended for generator operation, and the Logic/Trigger Board is a Rev. D or later no jumpers need to be cut. (Refer to *Figure 6 on page 18* for location of JP1)
- Apply power to the chiller and the LCSSS.
- On the OptiView Control Center, verify the following have been properly entered: (Refer to ASSOCIATED LITERATURE for Opti-View Control Center Operation Instruction form for your chiller type on page 3 of this form).
 - A. Local motor current limit setpoint
 - B. Pulldown demand limit
 - C. Chiller full load amps setpoint.
 - D. Supply voltage range setpoint.
 - E. Chiller starting amps setpoint.
 - F. KWH Reset
- The LCSSS is now ready to start the chiller.

FILL COOLING LOOP

The following procedure details the method of filling the cooling loop. The Style B LCSSS is shipped with a 50/50 mix of Propylene Glycol and YORK Corrosion Inhibitor. This type of coolant is being used to protect the cooling loop from damage due to freezing conditions during the shipping process. This coolant mixture does not have the thermodynamic properties required by the LCSSS during a running condition. Thus, this 50/50 mixture must be drained and replaced with YORK coolant as currently used in the LCSSS. Propylene Glycol is the same material used to winterize recreational vehicles. Although it is non-toxic follow local guidelines for proper disposal.

TABLE 9 - REQUIRED MATERIAL

ITEM	DESCRIPTION	QUANTITY
1	Funnel wide mouth	1 EA.
2	Bucket one gallon	1 EA.
3	Gallon container of YORK Coolant	1 EA.
4	Teflon tape	

Drain Procedure

1. Assemble the material listed above.
2. Remove the plastic pipe plug from the top of the coolant reservoir. Be sure to hold the coolant reservoir when removing the pipe plug.
3. Position the bucket under the drain cap. The drain cap is located below the coolant pump on the heat exchanger.
4. Remove the drain cap, capture the 50/50 mixture and discard the used coolant as suggested above. Do not reuse coolant. Remove J2, J3, J4 temporarily. The coolant pump will turn on to remove the rest of the coolant from the system.
5. After most of the 50/50 mixture has been drained, wrap the drain cap with Teflon tape, and replace the drain cap. Do not over-tighten the cap.

Fill Procedure

1. Fill the coolant reservoir with YORK Coolant until the level is 1/2 inch from the top of the coolant reservoir.
2. Remove J2, J3, J4 connectors and allow the coolant pump to run for a period of 5 minutes. Top off the level of the coolant.
3. Verify that the level of the coolant is within ¼ inch from the top of the coolant reservoir. If the coolant level is low, then add more YORK coolant.
4. Run the coolant pump for 10 minutes. Verify that the level of the coolant is proper. If the coolant level is low, then add more YORK coolant, and repeat this step.
5. Verify that all of the air has been worked out of the coolant. If not, continue to run the coolant pump, and add YORK coolant as required.
6. Reinstall the J2, J3, J4 connectors.
7. Wrap the plastic pipe plug with Teflon tape, and install on the coolant reservoir. Be sure to hold the coolant reservoir when installing the pipe plug.

SECTION 8 – MAINTENANCE AND TROUBLESHOOTING

MANUALLY RUNNING THE CLOSED LOOP COOLANT PUMP

The Style B LCSSS is now controlled by a microprocessor. The software for the microprocessor requires the LCSSS and the OptiView panel to be communicating through the communication link before the LCSSS closed loop coolant pump control software is enabled.

In order to manually run the closed loop coolant pump, all three of the thermistor connectors must be removed from the Logic/Trigger board. Refer to *SECTION 7 – START-UP INSTRUCTIONS* for more LCSSS start-up information.

COOLANT MAINTENANCE

The LCSSS cooling loop coolant must be changed every year. Refer to *Fill Cooling Loop on Page 33* for detailed LCSSS cooling loop fill information.

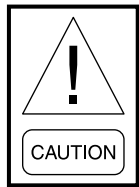

The probability of SCR heatsink corrosion is greatly increased if the coolant is not replaced within the stated time interval. If a unit failure occurs due to improper maintenance during the warranty period, Johnson Controls will not be liable for costs incurred to return the system to satisfactory operation.

Should the coolant become cloudy or brown in color, it must be drained and discarded. Fill the cooling system with a 50/50 mix of ethylene glycol. Run the cooling pump for 15 minutes. Drain this mixture from the cooling system, and discard following local guidelines for proper disposal. Fill the cooling system with distilled water. Run the cooling pump for 15 minutes. Drain the distilled water from the cooling system and discard. Fill the cooling system with the normal running inhibitor. The part number for the one gallon quantity of inhibitor is 013-04129-000.

Clear Coolant

There is no need to change the coolant should it become clear. Many samples of clear coolant were tested and determined to have the same properties as pink coolant.

Coolant Change Intervals

To ensure that the coolant maintains the designed properties **the coolant must be changed every year.** A coolant failure can result in a very expensive repair.

Do Not Reuse Coolant

In the event that the coolant must be removed to facilitate a repair to the LCSSS. All of the coolant must be drained, discarded, and new coolant installed. There have been a few events where the drained coolant became contaminated in the storage container. The contaminated coolant later failed in the LCSSS. **NEVER REUSE COOLANT!**

TROUBLESHOOTING THE CLOSED LOOP COOLANT PUMP

Should the closed loop coolant pump not function:

1. Verify that the OptiView panel is NOT displaying a LCSSS INITIALIZATION FAILED message. This is only a problem on initial power-up of the LCSSS. If communication between the LCSSS and the OptiView panel had been established and then is broken, the manual operation of the closed loop coolant pump would function. Refer to *Initialization Failed on Page 25* for details about the LCSSS INITIALIZATION FAILED message.
2. Verify that 7FU and 8FU in the LCSSS are not open. If they are open, then isolate the circuit to determine which circuit is shorted. Refer to the wiring diagram label inside the starter.
3. Verify 115 VAC from wire 107 to wire 2. If 115 VAC is not measured, then verify 4FU and 5FU in the LCSSS. If these fuses are okay, then verify input voltage to T1, and T1's primary wiring.
4. If all of the above are verified, then remove the J12 connector and place a jumper in it. If the closed loop coolant pump starts running, then a circuit on the Logic/Trigger board has failed. The Logic/Trigger board must be replaced. If the closed loop coolant pump does not run, then verify the wiring to the pump. If the wiring is okay, then replace the closed loop coolant pump.

TROUBLESHOOTING PROCESSES

The following procedures are designed to guide the service technician along the path that leads to the identification of the cause of the problem. The service technician should understand the operation of the LCSSS and function of each major component and Logic/Trigger Board. It is recommended that the service technician read and understand the information contained in this instruction prior to troubleshooting this product. Also,

the service technician must understand the system interface, and be able to utilize system wiring diagrams to follow signal flow throughout the system. Due to the integration of the LCSSS with the OptiView Control Center, a good working knowledge of the OptiView Control Center is also necessary (Refer to ASSOCIATED LITERATURE Forms listed on page 3).

Several levels of documentation are required for the troubleshooting process. The LCSSS wiring diagram, supplied with every starter, is the top level document. It provides the overall wiring and configuration. Sections of this instruction provide the required lower levels, specifically, block diagrams provide signal flow and simplified representations of Logic/Trigger Board circuitry. The “Inputs and Outputs” of the Logic/Trigger Board provide details of the required voltage levels at all connectors.

Begin the troubleshooting process by selecting the appropriate procedure. It is not necessary to sequentially perform all of them. Perform a procedure only if there is a problem with that function.

VERIFY SHORTED SCR

1. Remove main input power to the starter.
2. Set ohm meter to Rx1 range. If the ohm meter is a digital model, and has a diode test scale, place the meter in the diode test mode.
3. Connect the ohm meter from L1 to T1. If the SCR is shorted, the ohm meter will display a value less than 5 ohms. A reading greater than 5 ohms, but less than 5K ohms may indicate a leaky SCR or faulty snubber. Such SCRs and snubbers should be further evaluated.
4. Continue with the other two phases.
5. Replace the shorted SCR Assembly.

VERIFY OPEN OR SHORTED SCR GATE

1. Remove main input power to the starter.
2. Set ohm meter to Rx1 range. If the ohm meter is a digital model, and has a diode test scale, place the meter in the diode test mode.
3. Remove the suspected gate connection J6 – J11.

4. Insert the ohm meter probes into the connector. The meter should display a good value of 10 – 20 ohms in both polarities.
5. If the ohm value is lower than 5 ohms the gate is shorted, replace the SCR Assembly.
6. If the ohm value is greater than 50 ohms the gate is open, replace the SCR Assembly.

VERIFY GATE DRIVER OUTPUT

1. Remove main input power to the starter.
2. Set ohm meter to Rx1 range. If the ohm meter is a digital model, and has a diode test scale, place the meter in the diode test mode.
3. Remove the suspected gate connection J6 – J11 from the Logic/Trigger Board.
4. Connect the ohm meter negative lead to pin 1 and positive lead to pin 2 of the suspected Logic/Trigger Board output. The meter should display a good value of 10 – 20 ohms.
5. Connect the ohm meter positive lead to pin 1 and negative lead to pin 2 of the suspected Logic/Trigger Board output. The meter should display a good value of around 200 ohms.
6. If the ohm value is lower than 5 ohms, the gate driver is shorted.
7. If the ohm value is greater than 500 ohms, the gate driver is open. If the values are okay, continue.
8. Reconnect connector J6 – J11. Reapply main input power to the starter.
9. Connect a DC volt meter across the suspected J6-J11, pin 2 is ground. Without the starter running a voltage of 0 VDC should be displayed on the meter. With the starter running, a voltage of .55 – 2.0VDC should be displayed.
10. A higher voltage of around 5 – 10 VDC on the J6 – J11 connector would indicate a poorly conducting SCR. Replace the SCR Assembly.
11. A lower voltage during the running condition would indicate a shorted gate on the SCR, or a bad Logic/Trigger Board. Replace the appropriate part.

VERIFY REAL PHASE CURRENT IMBALANCE



The starter cabinet contains high voltages that can cause injury or loss of life. Extreme care should be taken when working on this equipment.

Use this section to determine if the current imbalance is real or a reporting problem.

1. Start the chiller.
2. Connect another current measuring device around the output wire to the motor.
3. Compare the measured three phase currents to each other.
4. If the currents are imbalanced, then continue. If they are not imbalanced, continue to section titled “Verify False Phase Current Imbalance”.
5. While the starter is running, record the three phases of input voltage.
6. Add the 3 values of voltage together, and divide by 3 to get the average voltage. Then take each measured value, subtract the average value, and divide this difference by the average value, and

multiply by 100. The result is the percentage phase imbalance for that phase. Depending on the load of the motor a value of 1.5% can cause a current imbalance of 15%. If this is not the source of the problem continue.

Example:

Phase A 480, Phase B 475, Phase C 482.

$480 + 475 + 482 = 1437 / 3 = 479$ avg.

$475 - 479 = -4 / 479 \times 100 = -0.8\%$

- Referring to the chart below, the current imbalance due to the voltage imbalance is 7.5 % at 60% load
- A typical motor of today may induce a current imbalance of up to 6%, but factory specifications allow for up to 8% before rejecting a motor. So, if the measured current imbalance is 13.5% or less, this is normal for the above example, and no more investigation is required. If this is not the source of the problem, continue.

Typical input voltage imbalance is 1 to 1½%. Excessive input voltage imbalance is 2% or greater. Most often imbalances are due to unequal distribution of single phase loads within the building.

7. Connect an AC voltage meter from L-1 to T-1.

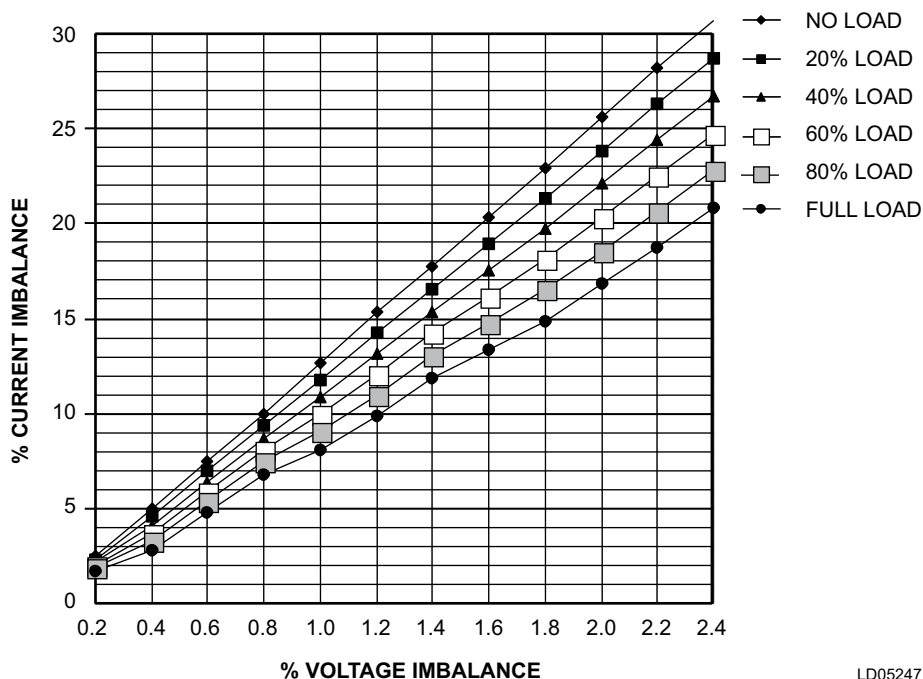

FIGURE 8 - CURRENT IMBALANCE DUE TO VOLTAGE IMBALANCE

- After the chiller has been running for one minute, measure the voltage across the SCR. The voltage should measure between .70 – 2.0 VAC. The voltage should remain stable. If the voltage is not stable, or is higher than 9.0 VAC, there could be a problem with the gate driver on the Logic/Trigger Board, or the SCR is not latching on. In the case of the SCR not latching on, this is typical of older starters. Verify each SCR pole by moving the meter to L-2 and T-2, and L-3 and T-3. This test verifies the operation of the starter. If these voltages are correct, then the problem is most likely other than the starter.

VERIFY FALSE PHASE CURRENT IMBALANCE

Use this section if the current imbalance is not real, but is a reporting problem.

- Verify that the OptiView Control Center has the correct model of starter selected. If not, verify wiring of the J1 connector. Refer to the current scaling section in this form.
- If this is not the source of the problem, continue.
- Remove main input power to the starter.
- Set ohm meter to Rx1 range. If the ohm meter is a digital model, and has a diode test scale, place the meter in the diode test mode.
- Remove the J1 connector, and measure the resistance of the three output CTs. The resistance value will vary depending on the model of the starter.

MODEL STARTER	CT RESISTANCE RANGE
7L	2.4 – 4.3 OHMS
14L	5.0 – 7.3 OHMS
26L	8.0 – 16.8 OHMS
33L	10.7 – 22.0 OHMS

- If this is not the source of the problem, continue.
- Measure resistance across J1 pin 1-2. A resistance value of 3.0 ohms should be displayed on your meter. This resistor is a 0.1% tolerance component. If it is out of tolerance, replace the Logic/Trigger Board. Repeat this step with J1 pin 3-4, and J1 pin 5-6.

- Reconnect the J1 connector.
- If this is not the source of the problem, continue.
- Start the chiller.
- Connect another current measuring device around the output wire to the motor.
- Compare the three phase current from the OptiView Control Center to the three measured currents.
- Replace the CT in the phase in which the current does not measure correctly.

REMOVING SCR ASSEMBLIES

Refer to the Replacement Parts List Form 160.00-RP3 for replacement SCR assembly kit part numbers.

- Remove AC power from system. If the starter has a circuit breaker, place it in the off position.
- Drain coolant as directed in the Fill Cooling Loop Section.
- Loosen the hose clamps and remove the hoses from the defective heatsink assembly.
- Place tape over the hose barbs, so that the coolant does not leak into the cabinet of the starter.
- Remove all electrical connections from the Logic/Trigger Board. Remove Logic/Trigger Board assembly by removing 4 panel mounting screws and the 6 screws holding the gate wire clamps.
- Disconnect the thermistor wire connector for the failed SCR (J/P16, J/P17, J/P18).
- Mark and then remove the output wires to the motor. Fold out of the way if possible.
- Remove the current transformer mounting bracket by removing the four screws on the back of the starter. Move CT assembly out of the way.
- Remove the two bolts connecting the SCR assembly to the bus bar.

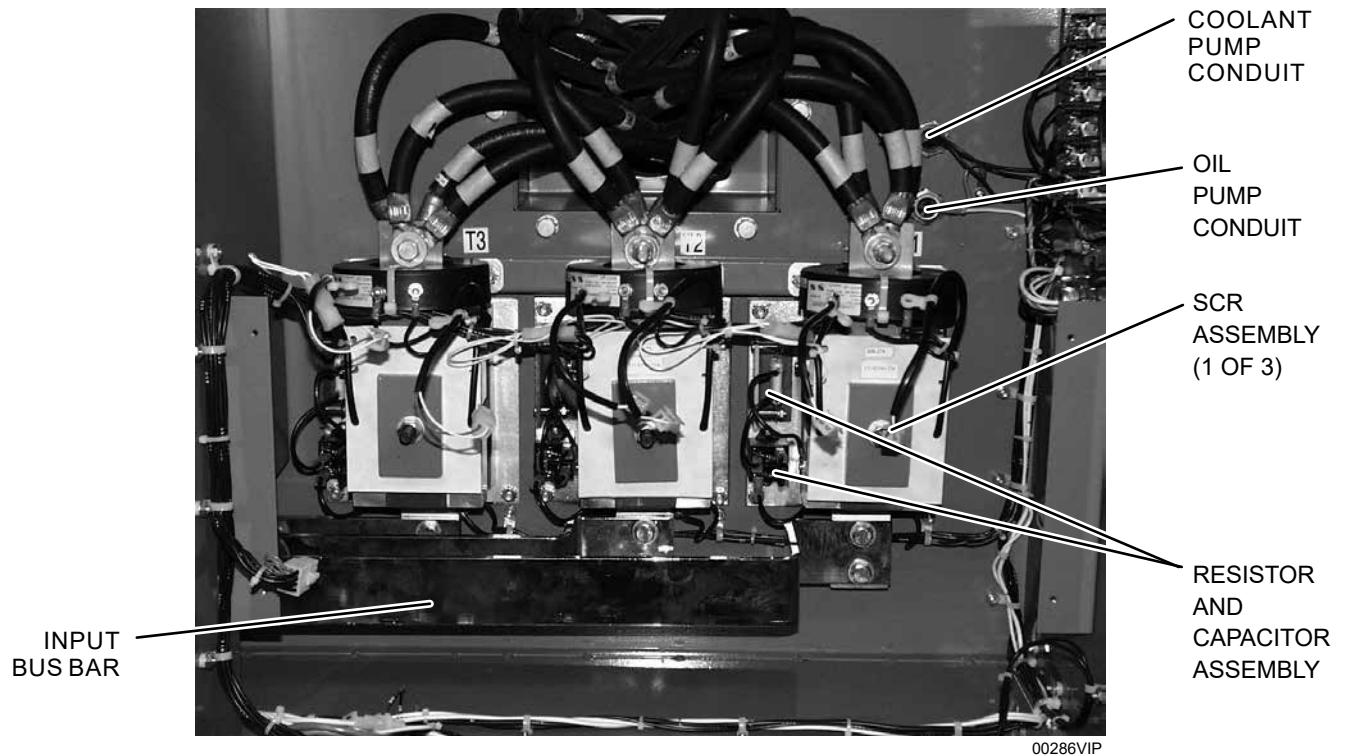

FIGURE 9 - LCSSS – POWER COMPONENTS

10. Remove the four SCR/heatsink assembly mounting nuts from the mounting studs and remove the entire SCR/Heatsink assembly.
11. Remove resistor and capacitor assembly from defective SCR assembly. Save these parts; they will be needed for the new SCR assembly. (Refer to *Figure 9 on page 39*)

INSTALLING SCR ASSEMBLIES

1. Install new plastic hose barbs into the new SCR assembly. Use Teflon tape on threads of the hose barbs.
2. Install resistor and capacitor assembly onto the SCR assembly.
3. Install SCR assembly into the starter and tighten the 4 mounting bolts.
4. Install the coolant hose over the hose barbs, and tighten the hose clamps (tubing must not contain any kinks).
5. On 7L and 14L models, it is necessary to clean the mating surfaces of the SCR assembly and input bus bar with fine emery cloth or Scotchbrite™

pad and coat with a thin film of thermal joint compound (013-02880-000) before attaching the input bus bar. Torque the two bolts to 13-17 ft.-lbs.

6. On 26L and 33L models, clean the mating surfaces of the SCR assembly and input bus bar with fine emery cloth or Scotchbrite™ pad. Torque the two bolts to 13-17 ft.-lbs.
7. Install the current transformer mounting bracket by inserting the four screws on the back of the starter.
8. Install the output wires from the motor.
9. Connect the thermistor wire connector for the new SCR (J/P16, J/P17, J/P18).
10. Install Logic/Trigger Board assembly by installing 4 panel mounting screws and the 6 screws holding the gate wire clamps. Install all electrical connections to the Logic/Trigger Board.
11. Fill the coolant loop as directed in the Fill Cooling Loop Section in this form.

The starter is now ready to be restarted.

