



Floor Polisher
225FP16TR
Operator's Manual

FOR YOUR SAFETY

DO NOT store or use gasoline or other flammable vapors and liquids in the vicinity of this or any other appliance.

Record This Important Information

Date of Purchase _____

Purchased From _____

Address _____

City _____ State _____ Zip _____

Phone _____ Contact _____

Machine Model _____

Machine Serial Number _____

Important Phone Numbers

Medical Emergency _____

Police _____

Fire Department _____

In this Operation Manual you will find three statements that you must read and observe to ensure safe operation of this machine.

DANGER! indicates that the possibility of severe bodily injury or death can occur if DANGER! statements are ignored. Read and observe all DANGER! statements included in the Operation Manual and attached to the machine.

WARNING! indicates that the possibility of bodily injury to the operator and other people can occur if WARNING! statements are ignored. Read and observe all WARNING! statements included in the Operation Manual and attached to the machine.

CAUTION! indicates that the possibility of damage to the machine or other property can occur if CAUTION! statements are ignored. Read and observe all CAUTION! statements included in the Operation Manual and attached to the machine.

Table of Contents

Technical Specifications.....	4	How to Operate the Machine.....	10
Safety Precautions.....	5	Installing the Pad Driver.....	10
Operator Responsibility.....	6	Operation.....	10
Machine Preparation.....	6	After Use.....	10
Unpacking the Machine.....	6	Scheduled Maintenance.....	11
Transporting the Machine.....	6	Machine Troubleshooting.....	11
Grounding Instructions.....	7	Parts Manual & Warranty.....	12
Machine Components.....	8	Electrical Schematic.....	13
Operator Handle Grips.....	9	Motor Assembly.....	14
Switch Levers.....	9	Gearbox Assembly.....	15
Switch Lever Safety Lock.....	9	Handle Assembly.....	16
Water Tank / Fill Cap.....	9	Main Assembly.....	18
Handle Release Lever.....	9	Tank Assembly.....	20
Cord Hook.....	9	Manufacturer's Warranty.....	22
Water Release Handle.....	9		
GFCI.....	9		
Power Cord.....	9		



WARNING! The Products sold with this Manual contain or may contain chemicals that are known to certain governments (such as the State of California, as identified in its Proposition 65 Regulatory Warning Law) to cause cancer, birth defects or other reproductive harm. In certain locations (including the State of California) purchasers of these Products that place them in service at an employment job site or a publicly accessible space are required by regulation to make certain notices, warnings or disclosures regarding the chemicals that are or may be contained in the Products at or about such work sites. It is the purchaser's responsibility to know the content of, and to comply with, any laws and regulations relating to the use of these Products in such environments. The Manufacturer disclaims any responsibility to advise purchasers of any specific requirements that may be applicable to the use of the Products in such environments.

Technical Specifications:

<u>Description</u>	<u>Specification</u>
Voltage (V)	120
Frequency (Hz)	60
Current (A)	15
Pad / Brush Speed	175 rpm
Power	1.5 hp (1.1 kW)
Gearbox	3-Planet
Pad/Brush Size	16" (41 cm)
Cord	12/3 Yellow SOOW
Cord Length	50' (15 m)
Height w/ Handle	46" (117 cm)
Width	16.6" (42 cm)
Length	23" (59 cm)
Weight w/ cord	90 lbs (41 kg)
Handle Tube	Tubular Steel
Main Frame	Die Cast Aluminum
Tank Capacity	2.50 gal (9.5 L)

Safety Precautions

Anyone operating the machine should read the following carefully and be informed of potentially dangerous operating conditions. Operators should be familiar with the location and use of all safety devices on the machine. DO NOT use the machine if it is not in proper operating condition, and report any damage or operation faults immediately.

DANGER! Failure to read the Owner's Manual prior to operating or attempting any service or maintenance procedure to your machine could result in injury to you or to other personnel; damage to the machine or to other property could occur as well. You must have training in the operation of this machine before using it. If you or your operator(s) cannot read English, have this manual explained fully before attempting to operate this machine.

DANGER! To reduce the risk of fire, use only commercially available floor cleaners, strippers, and waxes intended for machine application.

DANGER! Risk of explosion. Floor sanding can result in an explosive mixture of fine dust and air. To reduce risk of explosion, use floor sanding machine only in well ventilated area.

DANGER! Operating a machine that is not completely or fully assembled could result in injury or property damage. **DO NOT** operate this machine until it is completely assembled. Inspect the machine carefully before operation.

DANGER! Electrocutation could occur if maintenance and repairs are performed on a unit that is not disconnected from the power source. Disconnect the power supply before attempting any maintenance or service. Always remove the electrical plug from the electrical outlet before changing the brush, pad or other attachment and before leaving the machine.

DANGER! Using a machine with a damaged power cord could result in an electrocution. **DO NOT** use the machine if the power cord is damaged. **DO NOT** use the electrical cord to move the machine.

DANGER! Grinding of concrete and other materials with silica in the composition may give off dust or mists containing crystalline silica. Repeated and/or substantial inhalation of airborne crystalline silica can cause serious or fatal respiratory diseases, including silicosis. In addition, California and some other authorities have listed respirable crystalline silica as a substance known to cause cancer.

DANGER! This machine should only be used to wet grind and polish concrete and other materials containing silica. Dry grinding will increase exposure to crystalline silica.

WARNING! Water solutions used with this type of machine can leave wet areas on the floor surface. These areas can cause a dangerous condition for the operator or other persons. Always put "CAUTION" signs near the area being cleaned.

WARNING! Modifications or alterations to this machine can lead to personal injury or damage to the machine. **DO NOT** make unauthorized modifications or alterations to this machine. Amano Pioneer Eclipse assumes no liabilities for injury or damage resulting from an unauthorized modification or alteration to the machine. Any unauthorized modification or alteration to this machine voids all warranties.

WARNING! Electrical components of this machine can "short-out" if exposed to water or moisture. Keep the electrical components of the machine dry. Wipe the machine down after each use. For storage, keep the machine in a dry building.

WARNING! Always use a three-wire electrical system connected to the electrical ground. For maximum protection against electric shock, use a circuit that is protected by a ground fault interrupter. Consult your electrical contractor.

WARNING! To prevent damage to the power cord, **DO NOT** let the brush, pad, pad driver or wheels touch the power cord when the machine is running. Always lift the cord over the machine. **DO NOT** pull the power cord to move the machine.

WARNING! Operating a machine without observing all labels and instructional information could result in injury or damage. Read all machine labels before attempting to operate. Make sure all of the labels and instructional information are attached or fastened to the machine. Get replacement labels and decals from your authorized distributor.

WARNING! Sanding wood or varnish produces dust that could self ignite and could cause injury or damage. Dispose accordingly.

WARNING! Use of this machine as a step or furniture could result in injury or damage. **DO NOT** use this machine as a step or furniture. **DO NOT** ride on this machine.

WARNING! To avoid injury keep hands, feet and loose clothing away from all moving parts of this machine.

WARNING! Injury to operator or bystanders could occur if an abrupt change in floor surface texture is encountered when using this machine. Abrupt change in floor surface texture can cause a sudden pulling motion by this machine. This sudden pulling motion can result in loss of control of the machine which could injure the operator or bystanders. Avoid motions that could cause machine to cross from a smooth floor surface to a carpeted or rough texture floor surface. Avoid motions that could allow the machine to come in contact with low obstacles, such as floor electrical outlets, door stops or entry molding, etc.

WARNING! Any alterations or modifications of this machine could result in damage to the machine or injury to the operator or other bystanders. Alterations or modifications not authorized by the manufacturer voids any and all warranties and liabilities.

CAUTION! The machine is heavy. Get assistance before attempting to transport or move it.

CAUTION! When draining liquids from the machine, follow all local and federal waste disposal standards.

This Machine is Manufactured for Commercial use only.

This machine is designed and manufactured for indoor use on hard floor surfaces. Amano Pioneer Eclipse Corporation (APEC) does not recommend use of this machine in any environment other than an indoor environment. This floor machine is designed and manufactured for commercial floor use only. This machine is designed to clean most modern types of floors including composition tile, stone, marble, terrazzo, and resilient floor covering, and some coated wood floors.

Operator Responsibility

The operator is responsible for performing the recommended daily maintenance and checkups of the machine to keep it in good working condition. The operator must inform the service mechanic or supervisor when recommended maintenance procedures are required as prescribed in the "MAINTENANCE" section of this manual.

FOR SAFETY: DO NOT operate machine before reading and understanding the operation manual.

Keep your machine regularly maintained by following the maintenance information in this manual. Order parts and supplies only from an Authorized Amano Pioneer Eclipse Distributor. Use the parts illustration section of your manual when ordering parts.

During and after operation, perform the recommended daily and hourly procedures outlined in the Maintenance Chart.

Machine Preparation

Unpacking the Machine

When the machine is delivered, carefully inspect the shipping carton and the machine for damage. Unpack the machine with caution. If damage is evident, save the shipping carton so that it can be inspected. Contact the Amano Pioneer Eclipse Customer Service Department.

Transporting the Machine

To transport the machine, follow this procedure:

1. Raise and lock the handle in the upright position. To lock the handle, push down on the handle release lever (See Figure 1).
2. Unplug the machine from wall outlet and wrap cord around the handle and cork hook.
3. To pick up the machine, using two people, lift and place in cargo area (See Figure 2).

Figure 1

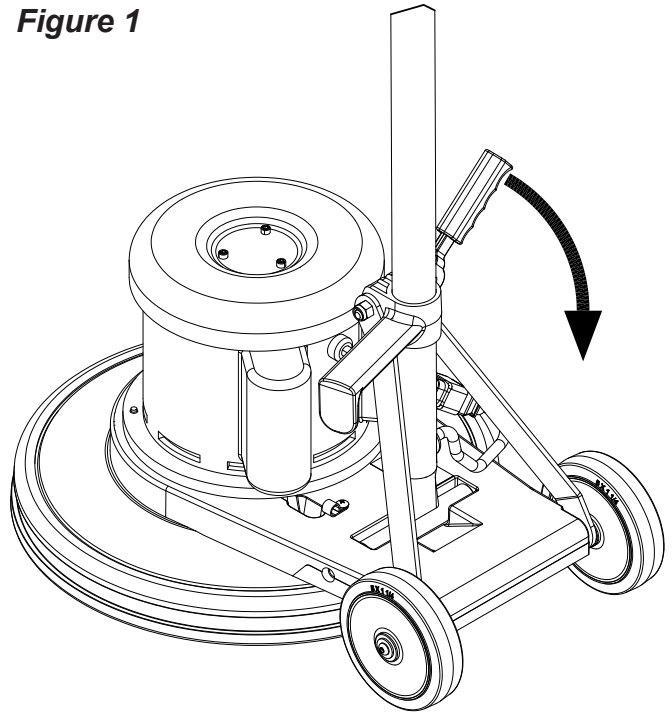

WARNING! The machine is heavy, 90 lbs (41 kg) without the cord. To avoid injury or damage to the machine use a firm grip and proper lifting technique. Always use two people when lifting this machine.

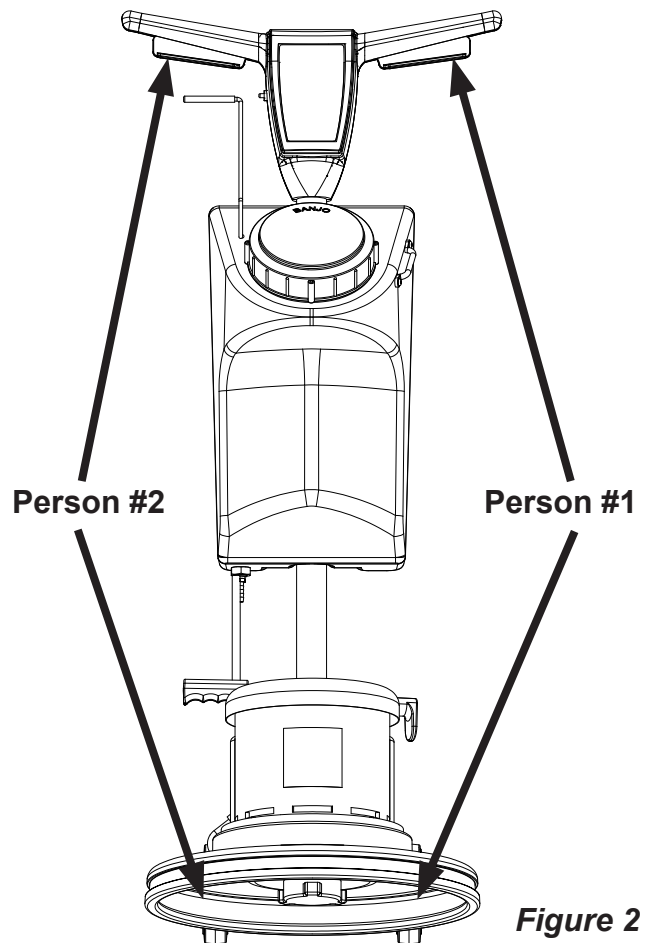

Figure 2

Grounding Instructions

120 Volt Machines

This product must be grounded while in use to protect the operator from electrical shock. The machine is provided with a three-conductor cord and a three contact grounding attachment plug to fit the proper grounding type receptacle. The green (or green and yellow) conductor in the cord is the grounding wire. NEVER connect this wire to other than the grounding pin of the attachment plug. If it should malfunction or breakdown, grounding provides a path of least resistance for electric current to reduce the risk of electrical shock. This product is equipped with a cord having an equipment-grounding conductor and grounding plug. The plug must be inserted into an appropriate outlet that is properly installed and grounded in accordance with all local codes and ordinances.

WARNING: Improper connection of the equipment-grounding conductor can result in a risk of electric shock. Check with a qualified electrician or service person if you are in doubt as to whether the outlet is properly grounded. **DO NOT** modify the plug provided with the product - if it will not fit the outlet, have a proper outlet installed by a qualified electrician.

This product is for use on a nominal 120 volt circuit and has a grounding attachment plug that looks like the plug illustrated as (A) in the sketch. Make sure that the machine is connected to an outlet having the same configuration as the plug. No adapter should be used with this product.

WARNING: To prevent possible electric shock, protect the machine from rain. Keep the machine in a dry building.

WARNING: To prevent possible electric shock, always use a 3-wire electrical system connected to the electrical ground.

This machine is equipped with a Ground Fault Circuit Interrupter (GFCI) for protection against electrical shock. If the GFCI trips, locate and correct the problem before resetting the GFCI.

WARNING: DO NOT cut, remove or break the ground pin. If the outlet does not fit the plug, consult your electrical contractor.

WARNING: Have worn, cut or damaged cords replaced by an authorized service person.

Extension Cords

Use only an approved extension cord with three conductors, a plug with three terminals, and a connector body with three holes. The machine has a power cord with wire size 12 AWG (AWG means American Wire Gauge).

WARNING: If you use an extension cord, use an extension cord with minimum wire size 12 AWG. **DO NOT** use an extension cord longer than 50 feet. **DO NOT** join two extension cords.

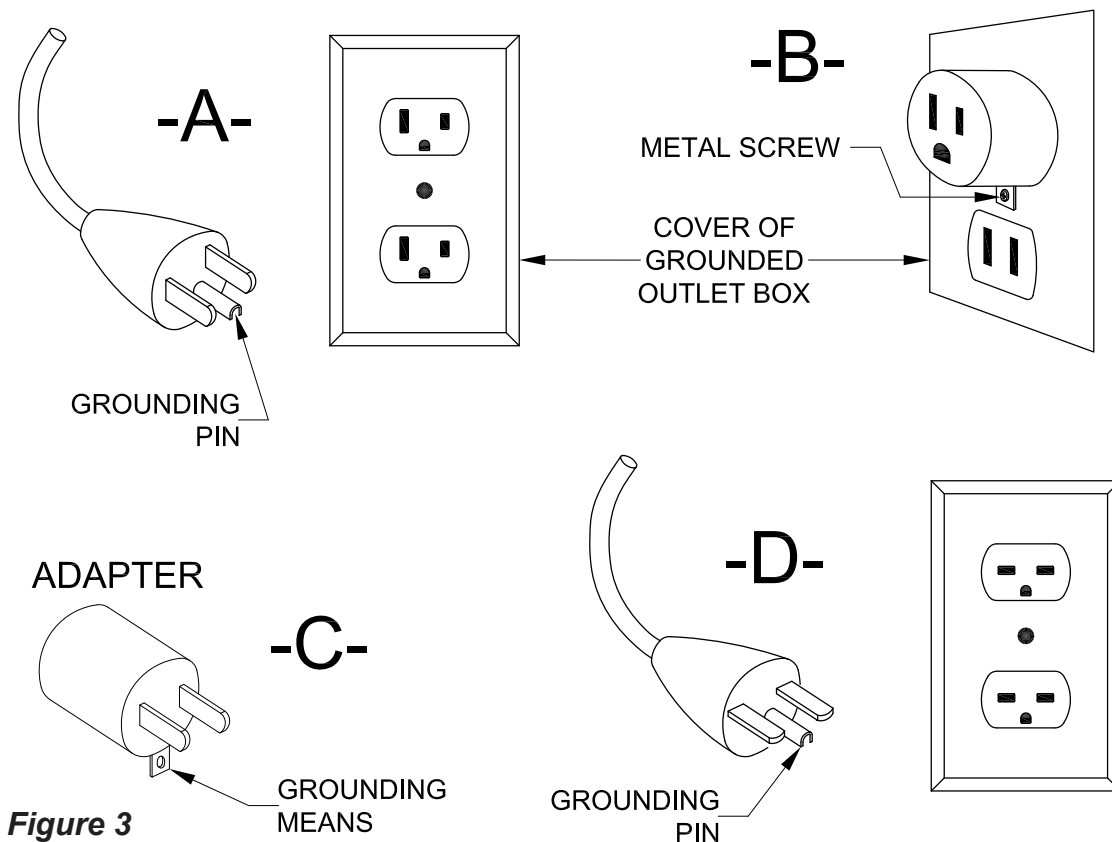
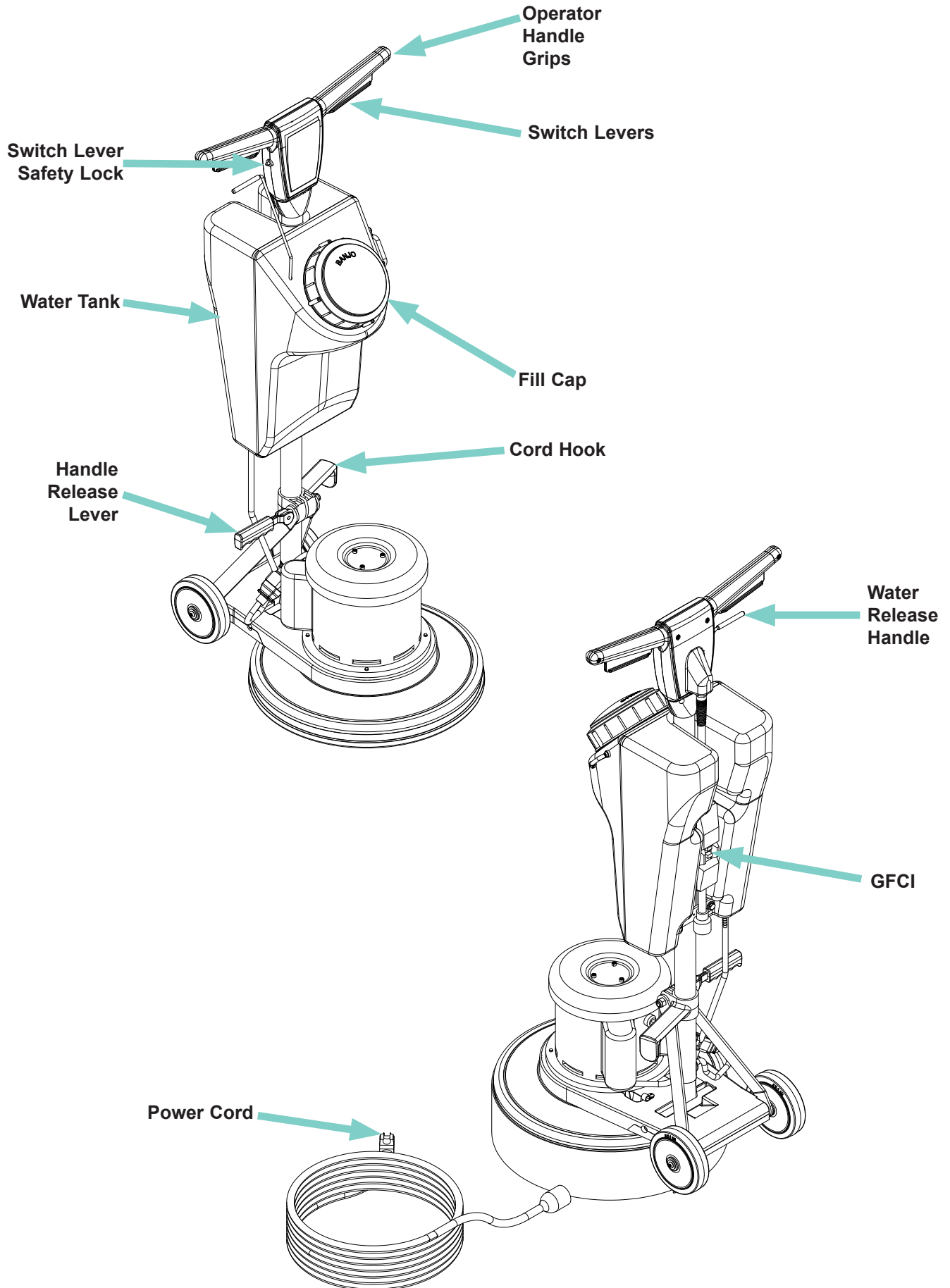

Figure 3

Machine Components



Operator Handle Grips

Use the operator handle grips to operate and move the machine. The switch levers on the underside of the handle grips, turn the motor on and off. Locate the handle grips in a comfortable operating position and lock the handle release lever in place. While operating the machine, slightly raising or lowering the operators handle will help the operator control the machine.

Switch Levers

The switch levers activate the switch module to turn the motor on and off. The switch module will not activate unless the switch lever safety lock is pressed first. To operate the machine, only one switch lever has to be engaged. This allows the operator to alternate hands while using the machine. To stop the motor from turning, release the switch levers.

Switch Lever Safety Lock

The switch lever safety lock is to prevent someone from accidentally turning the machine on. To turn the machine on, always make sure the handle is lowered in the operators position and the handle release lever is locked. Push and hold the switch lever safety lock with one hand, while engaging one of the switch levers. Once the machine has started, the switch lever safety lock can be released.

Water Tank / Fill Cap

The water tank can be filled with clean water. This tank is for water only. **DO NOT** place any flammable, corrosive, and/or toxic liquids and powders in the water tank. Remove the fill cap to add water to the tank and replace the cap to prevent splashing of water on the electrical components during use. Always drain any remaining water from the tank before storage.

Handle Release Lever

This handle is used to release or lock the operators handle. Pulling up on the lever will allow the handle to move freely. Pushing down on the lever, horizontally, will lock the handle in place. The handle should always be locked while in use, as well as during transport or storage.

Cord Hook

To prevent the cord from being damaged while not in use, wrap the cord around the cord hook and the top of the operators handle.

Water Release Handle

Pulling up on this handle will open the valve inside the tank and allow water to flow from the water tank to the driver. Water will only flow from the tank while the handle is raised. To stop the flow of water from the tank, release the handle. The amount of flow can be varied by how far the handle is raised.

To drain the water tank, place the machine over a drain. Remove the fill cap and use the water release handle to drain the tank. Replace fill cap when finished.

GFCI

The GFCI is a safety device to protect from electrical shock. The GFCI monitors the current flowing through the circuit. If the flowing current differs by a small amount from the returning current, the GFCI interrupts the power. When the GFCI shuts down the power going to the machine, check the machine and power cord for any faults or issues. Press the reset button to continue working. If the GFCI repeatedly shuts off the machine, have the machine serviced.

To test the GFCI, push the test button and if the machine has no power, the device is working properly. If the machine still operates, stop using the machine immediately and have it serviced. After verifying the GFCI is functioning properly, push the reset button and continue working.

Power Cord

Use only the supplied power cord with this machine. The power cord is sized to be used with this machine. To attach the power cord to the machine, insert plug on the back of handle into the female receptacle of the power cord. Properly align the plug pins with the holes of the receptacle, push together and twist to lock the cords in place.

How to Operate the Machine

Installing the Pad Driver

WARNING! Make sure lid is secure on water tank before tilting back the machine.

Place the handle in the upright (vertical) positions and lock the handle release lever. Tilt the machine back on the transport wheels and let the handle rest on the floor.

Align the lugs with the corresponding slots in the pad driver and turn the pad driver counterclockwise to lock it in place. To remove pad driver, give it a quick hard turn clockwise.

CAUTION! Using the wrong pad, brush, or tooling on this machine can overload the motor.

Figure 4

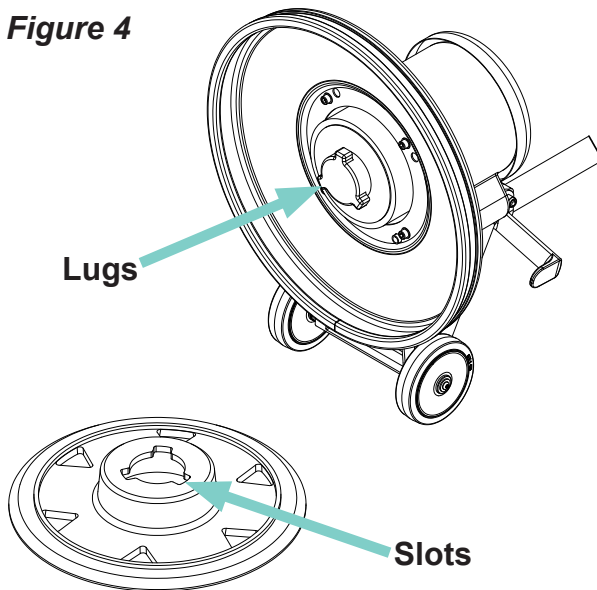

Operation

1. Unwrap the power cord and plug it into the properly grounded outlet.
2. Pull up on the handle release lever (5). Move the operator handle (7) downward until your arms are almost straight. Push down on the handle release lever (5) to lock it in place.
3. Lift up on the operator handle (7) until the driver is flat against the floor.

WARNING! Be prepared to control the machine as soon as the motor starts. Just a slight up or down movement of the operators handle (7) will make the machine move from side to side. Raise the handle to go right. Lower the handle to go left.

CAUTION! Immediately start moving the machine back and forth. Keep the machine moving while the motor is running to avoid damage to the floor.

4. Hold one of the operator handle grips (1) firmly, push the switch lever safety lock (2) and then compress the switch lever (3) to start the motor.

Note: When the switch levers (3) are released, the machine shuts off immediately.

5. To release water from the water tank, pull up on the water release handle (4). The water will stop flowing once the handle is released.

After Use

1. Place the operators handle (7) in the upright (vertical) position and unplug the power cord. Wrap the power cord around the operator hand grips (1) and the cord hook (6).
2. Tilt the machine back and remove the pad driver from the machine. **NEVER** store the machine with the pad driver on the machine.
3. If there is any water in the water tank, place the machine over a drain. Using the water release handle (8), drain the water tank.
4. Wipe the entire machine with a clean, damp cloth.
5. Inspect the entire machine and all accessories for damage. Perform any required maintenance or repairs before storage.
6. Store the machine in a clean, dry place with the operator handle (7) locked in the upright position.

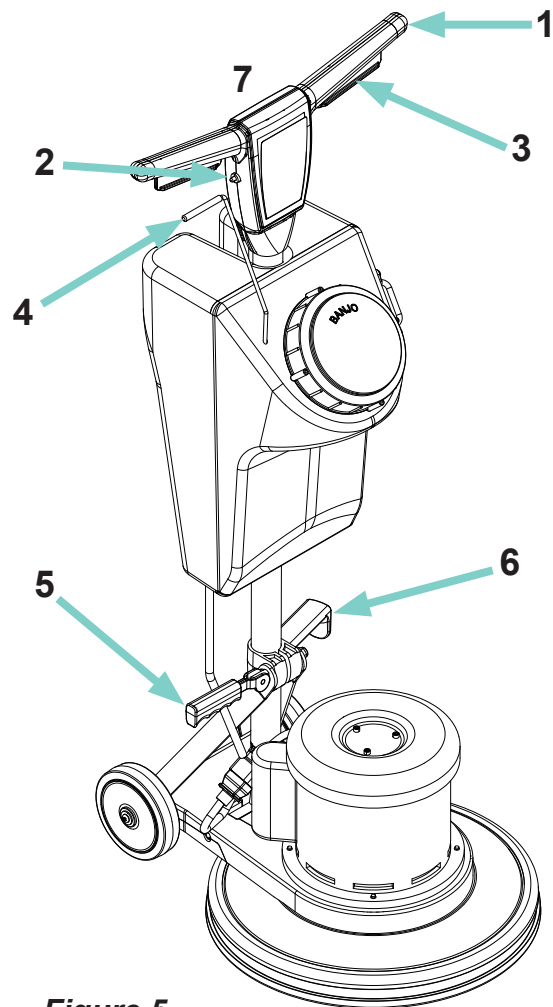

Figure 5

Scheduled Maintenance

Operation	Interval				
	Daily	Weekly	Monthly	Every 6 Months	Annually
Empty the water tank	●				
Remove driver / pad holder	●				
Check for loose or lost fasteners	●				
Inspect hoses and connections	●				
Inspect driver / pad holder for damage	●				
Clean the machine and accessories	●				
Test the GFCI		●			
Check the power cord for damage		●			
Check machine wiring for fray or cut			●		

These items must be performed with the proper tools and training. Contact an Amano Pioneer Eclipse Factory Certified Technician unless you have the proper equipment and mechanical proficiency.

Machine Troubleshooting

Problem	Possible Cause	Solution
Machine will not start	No power	Check the main power supply (building circuit breaker).
		Check the cord connection at the wall outlet
	Switch lever safety lock not depressed	Hold in the switch lever safety lock and then engage switch levers.
	Bad connection	Check the motor and cord interlock connections.
	GFCI tripped	Push the reset button. If problem continues, contact an authorized APEC distributor
	Bad motor start capacitor	Contact an authorized APEC Distributor.
Motor runs sluggish	Low voltage	Using extension cord with wire smaller than 12/3. Replace with a 12/3 extension cord.
		Using more than one extension cord. Only use one 50ft 12/3 extension cord.
	Bad motor run capacitor	Contact an authorized APEC Distributor.
Fuse / circuit breaker repeatedly trips	Low voltage	Eliminate extension cord & locate a power source closer to work site.
		Have voltage checked by a qualified electrician.
	Not on a dedicated circuit	Make sure there is no other items using power on the circuit.
	Motor is overloaded	Try a different driver/head that is less aggressive.
		DO NOT add weight to machine. Remove any excess weight added to machine.
Bad connection	Contact an authorized APEC Distributor.	
Machine wobbles during operation	Defective pad	One side is more dense than the other. Replace pad.
	Machine left setting on pad for extended time	Pad has taken "a set". Replace pad.
	Warped block on brush or padholder	Replace.
	Block not installed properly	Remove and install properly.

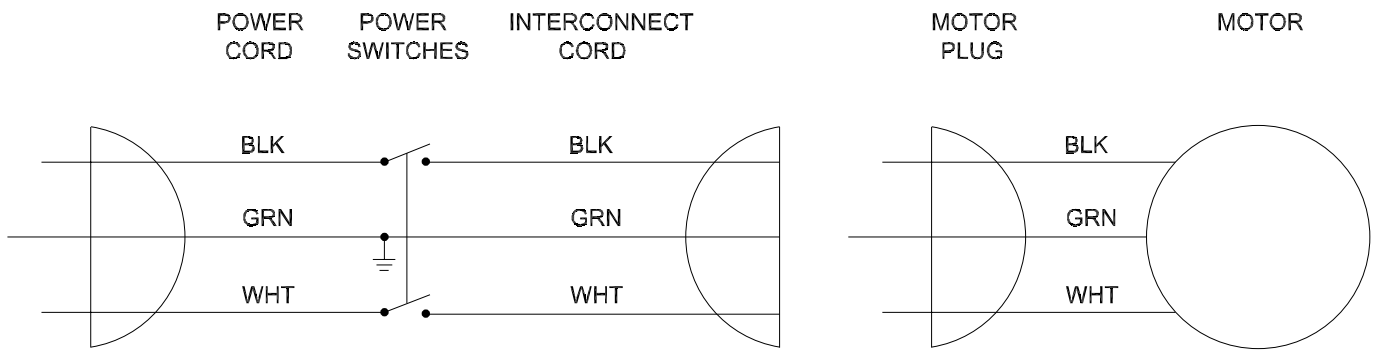

Motor Assembly

ELECTRICAL SCHEMATIC (120V)

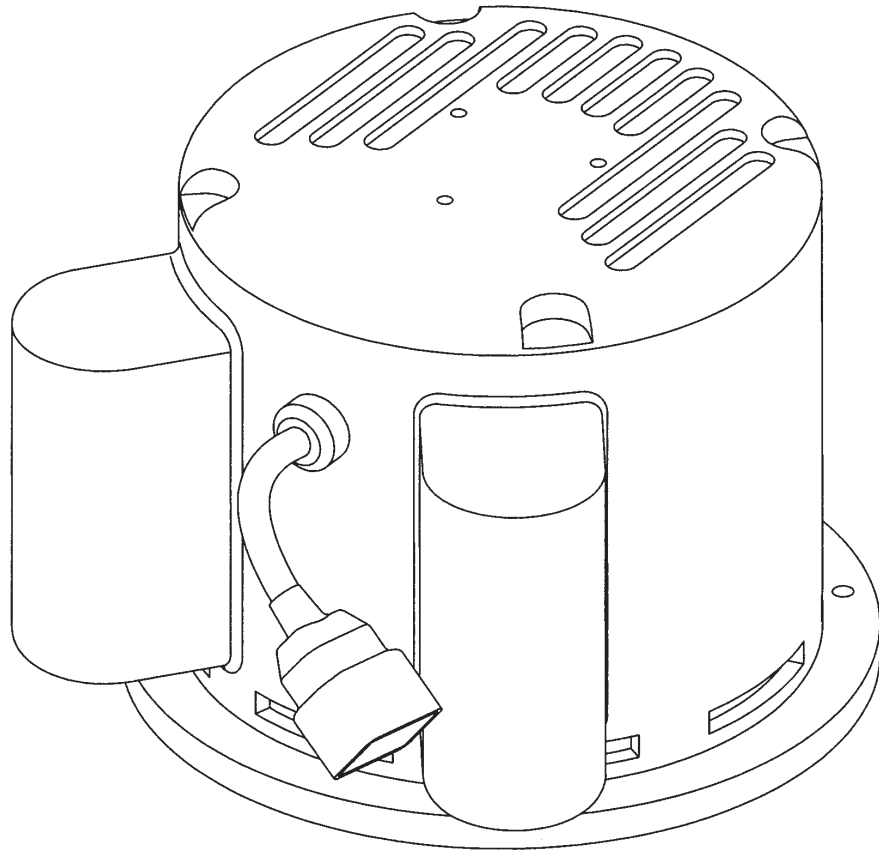
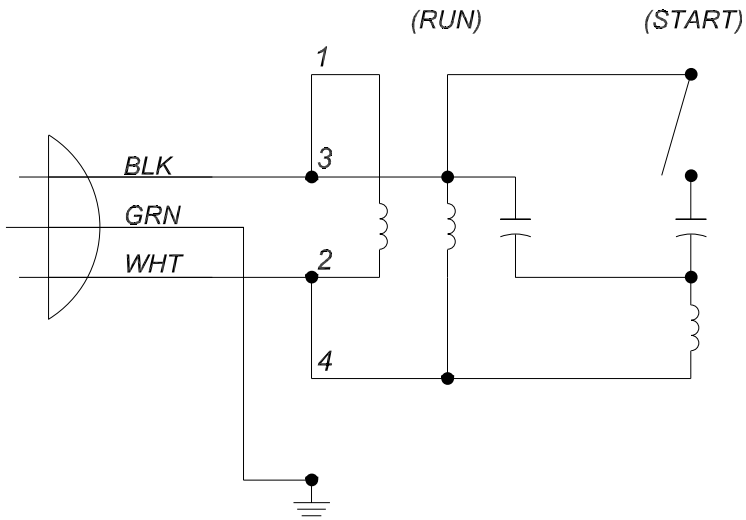

<u>Item</u>	<u>Ref. No.</u>	<u>Description</u>	<u>Qty</u>	<u>Item</u>	<u>Ref. No.</u>	<u>Description</u>	<u>Qty</u>
1	40694A	CAPACITOR, START	1	6	53848A	PLATE, MOUNTING	1
2	53191A	CAPACITOR, RUN	1	7	40698A	ENDBELL	1
3	53360A	COVER, CAPACITOR	2	8	41053A	CORD, IEC	1
4	53190A	SWITCH, START	1	9	747553	RELIEF, STRAIN	1
5	902550	BEARING, BALL, 6203	1				

Gearbox Assembly

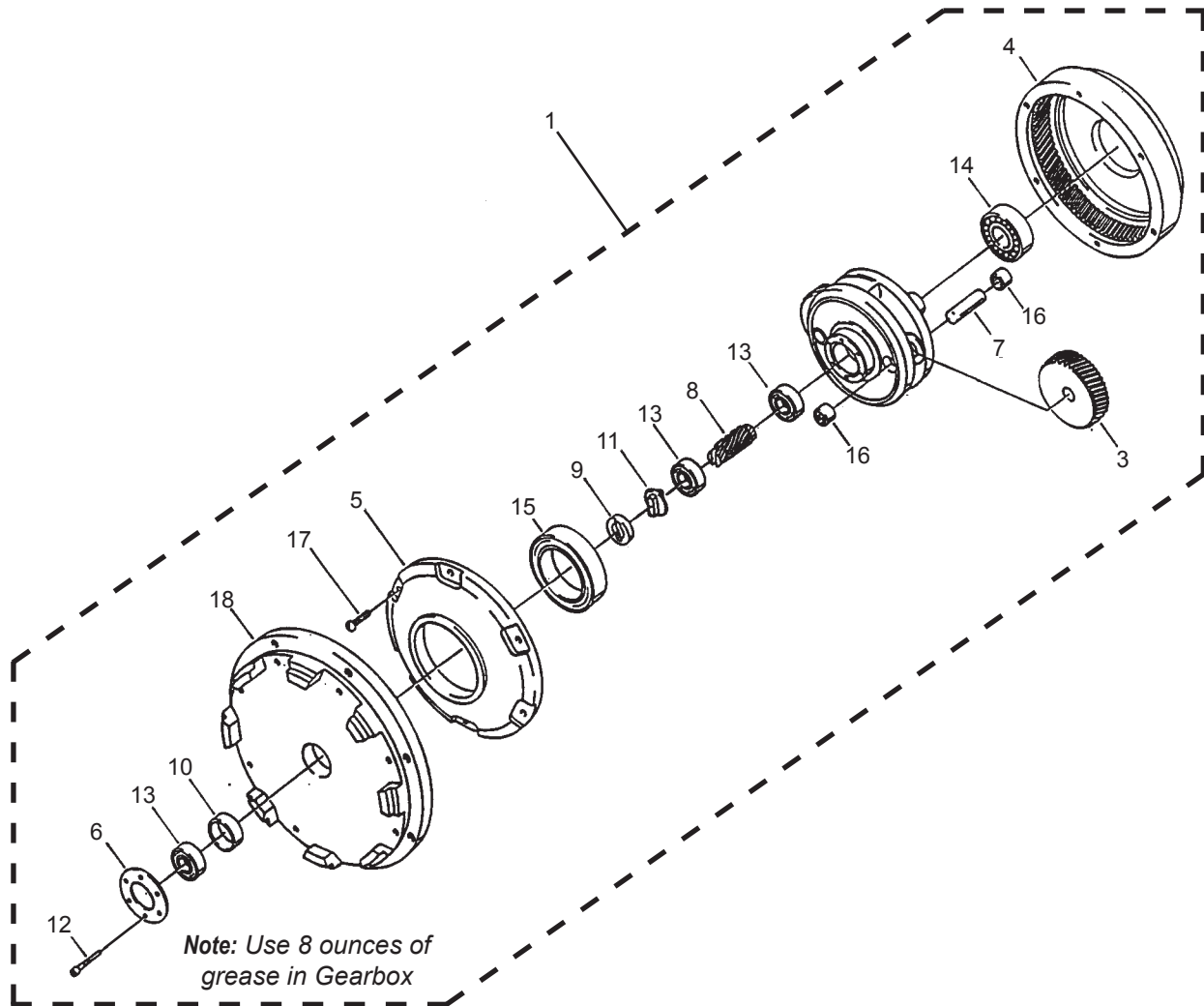

<u>Item</u>	<u>Ref. No.</u>	<u>Description</u>	<u>Qty</u>	<u>Item</u>	<u>Ref. No.</u>	<u>Description</u>	<u>Qty</u>
1	53646A	GEARBOX, 1.5 HP	1	10	58520A	SPACER, SLEEVE	1
2	503802	GREASE, 14 OZ (<i>NOT SHOWN</i>)	1	11	69195A	COUPLING, SHAFT	1
3	54408A	GEAR, PLANET	3	12	80141A	SCREW, #10 -32 X 1"	6
4	54856A	GEAR, RING	1	13	902606	BEARING, BALL, 6002	3
5	54858A	COVER, GEARBOX	1	14	902654	BEARING, BALL, 6204	1
6	56922A	RETAINER, BEARING	1	15	902736	BEARING, BALL, 6010	1
7	58312A	SHAFT, PLANET	3	16	902737	BEARING, NEEDLE	6
8	58313A	GEAR, PINION	1	17	84808A	SCREW, #10-24 X 3/4"	6
9	58314A	RETAINER, SHAFT	1	18	53848A	PLATE, MOUNTING	1

Handle Assembly

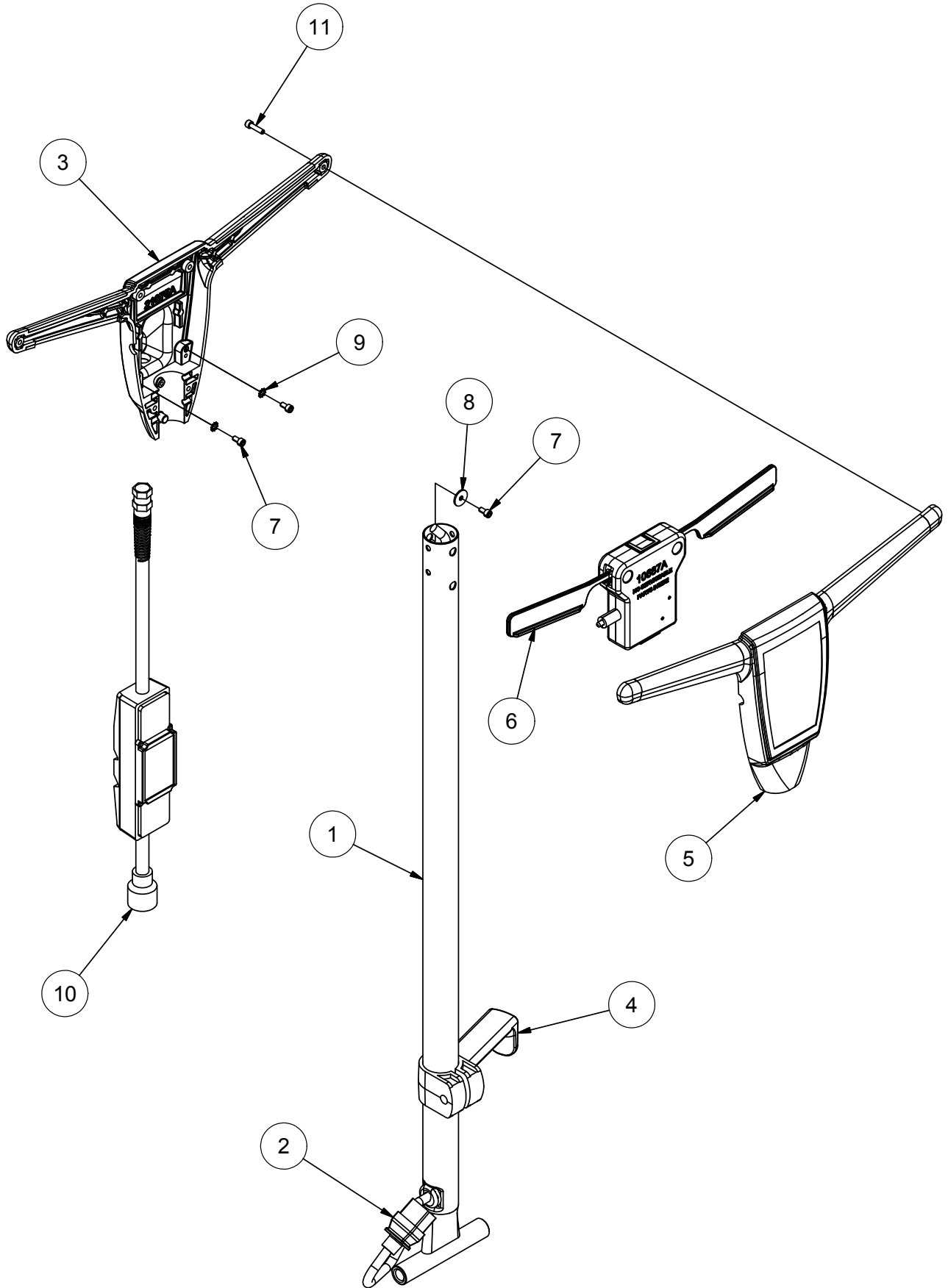

RF062000

050416

Handle Assembly (continued)

<u>Item</u>	<u>Ref. No.</u>	<u>Description</u>	<u>Qty</u>
1	61373A	TUBE, HANDLE	1
2	40789A	CORD, INTERCONNECT	1
3	21075A	HANDLE, REAR	1
4	50781A	CLAMP, HANDLE	1
5	21074A	HANDLE, FRONT	1
6	10687A	MODULE, INTERLOCK, ASM.	1
7	80290A	SCREW, #10 X 3/8"	3
8	80291A	WASHER, FLAT, #10	1
9	980603	WASHER, EXT LK, #10	2
10	MP484700	CORD, ADAPTER, GFCI	1
11	80284A	SCREW, #10 X 3/4"	6

Main Assembly

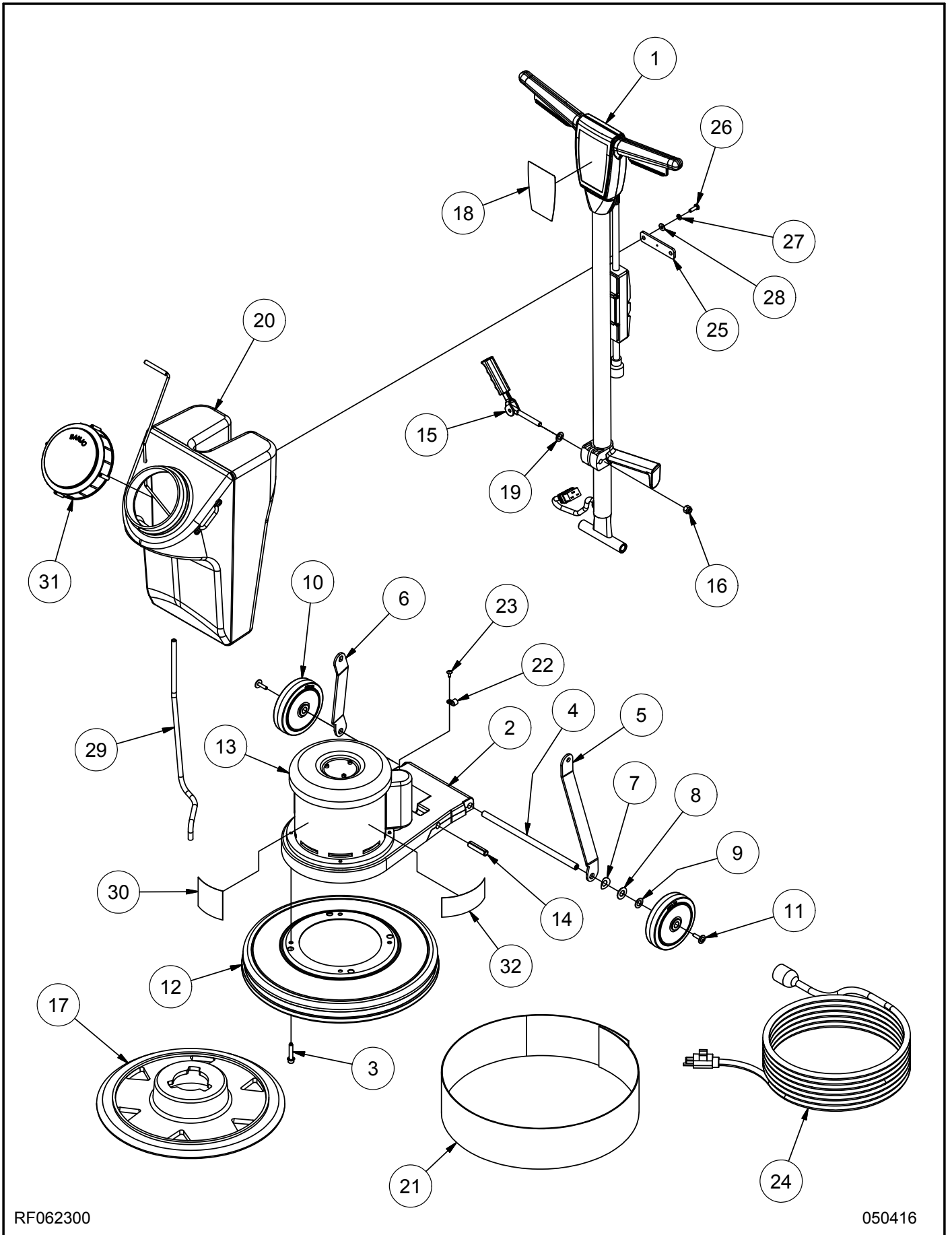

RF062300

050416

Main Assembly (continued)

<u>Item</u>	<u>Ref. No.</u>	<u>Description</u>	<u>Qty</u>	<u>Item</u>	<u>Ref. No.</u>	<u>Description</u>	<u>Qty</u>
1	MP498500	HANDLE, ASM.	1	17	MP481100	DRIVER, PAD	1
2	21088A	FRAME, MAIN	1	18	MP499200	DECAL, HANDLE, 225FP	1
3	80294A	SCREW, SH, 5/16" X 1-5/8"	4	19	980349	WASHER, WEAR	1
4	61725A	AXLE	1	20	MP484900	TANK, WATER, 2-1/2 GAL, ASM.	1
5	61740A	ARM, LINK, LEFT	1	21	56383098	SKIRT, TALL	1
6	61741A	ARM, LINK, RIGHT	1	22	NB021600	CLAMP, 3/8"	1
7	80295A	WASHER, BOWED, .516" ID	2	23	NB064900	SCREW, #10 X 1/2"	1
8	980648	WASHER, 17/32" ID	2	24	40722A	CORD, POWER, 12/3, 40FT	1
9	980673	WASHER, FLAT, 1/2"	2	25	MP486401	PLATE, MOUNTING	2
10	39857A	WHEEL, 5"	2	26	NB019100	BOLT, HEX, 1/4" X 3/4"	4
11	80292A	SCREW, 1/4" X 1.00"	2	27	NB6110	WASHER, LOCK, 1/4"	4
12	11006A	SHROUD, w/ BUMPER, ASM.	1	28	NB3350	WASHER, FLAT, 1/4"	4
13	53650A	MOTOR/GEARBOX, 1.5HP	1	29	MP473900	TUBING, 1/4" ID	24"
14	53833A	PIN, SPLIT, 1/2"	2	30	MP498300	DECAL, APEC, 3"	1
15	56109699	CAM, w/ GRIP, ASM.	1	31	MP487700	CAP, 6", TANK	1
16	920342	NUT, LOCK, 3/8"	1	32	70825A	LABEL, HDTR, 2" X 5"	2

Tank Assembly

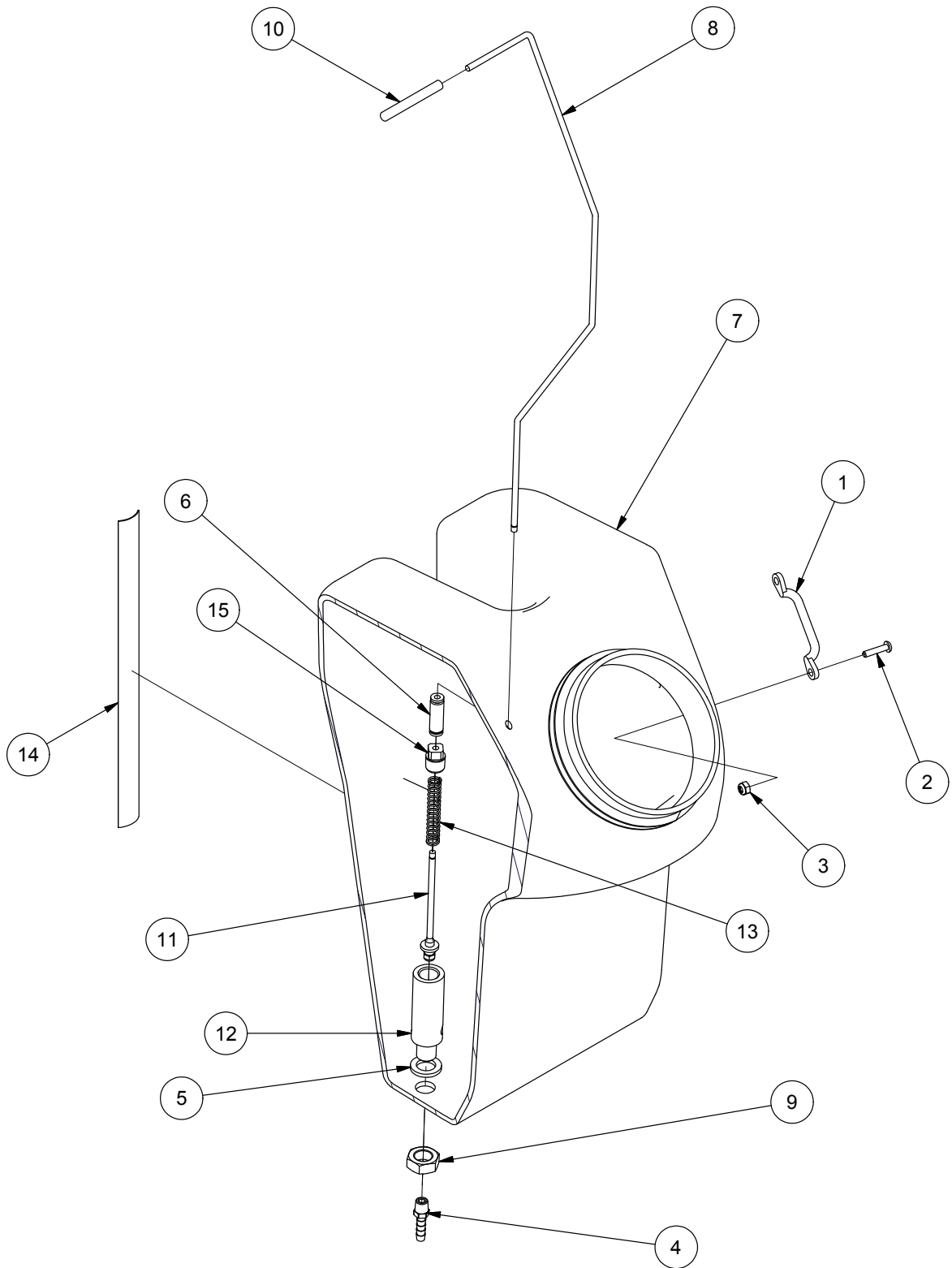

Tank Assembly (continued)

<u>Item</u>	<u>Ref. No.</u>	<u>Description</u>	<u>Qty</u>	<u>Item</u>	<u>Ref. No.</u>	<u>Description</u>	<u>Qty</u>
1	RV009500	LOOP, FOOTMAN	1	9	920280	NUT, JAM, 5/8"	1
2	NB049100	SCREW, BH, #10 X 7/8"	2	10	MP485900	GRIP, 3/16" X 2.50"	1
3	NB030700	NUT, LOCK, #10	2	11	MP487000	PLUG, VALVE, ASM.	1
4	MP252000	FITTING, 1/8" MNPT X 1/4" HB	1	12	MP485200	HOUSING, VALVE	1
5	MP485600	GASKET, 5/8" ID	1	13	MP485400	SPRING, VALVE	1
6	MP486100	FITTING, UNION, 3/16"	1	14	MP490000	TAPE, ANTI-SLIP	12"
7	MP485000	TANK, WATER, 2-1/2 GAL.	1	15	321AB	BONNET, VALVE	1
8	MP485700	LINK, HANDLE	1				

Limited Warranty

PE225FP HDTR

TO QUALIFY FOR THIS WARRANTY

- (1) Machine must be registered at the time of purchase on a form provided by Amano Pioneer Eclipse Corporation. Your Amano Pioneer Eclipse Corporation Distributor is responsible for the registration of your machine. Please cooperate with your Distributor in supplying necessary information on the card.
- (2) The machine must have been purchased from Amano Pioneer Eclipse Corporation or an authorized Amano Pioneer Eclipse Corporation Distributor.
- (3) This warranty extends to the original purchaser only and is not transferable to subsequent owners.

TIME PERIODS

- (1) ONE YEAR WARRANTY. Warranted to be free from defects in material and workmanship for a period of one (1) year from the date of purchase by the original owners. (See Exclusions.)
- (2) ONE (1) YEAR WARRANTY - For labor necessary to make warranty repairs.

EXCLUSIONS (Not Covered by Warranty)

- (1) Parts that fail through normal wear by reason of their characteristics (cords, motor brushes, wheels, pad holder, skirt, or other consumable parts).
- (2) This warranty does not extend to parts affected by misuse, neglect, abuse or improper maintenance. All defective parts must be returned to the distributor for credit.

THE OBLIGATION OF AMANO PIONEER ECLIPSE CORPORATION

- (1) The obligation of Amano Pioneer Eclipse Corporation under this warranty is limited to repairing or replacing, at its option, any part which is proven to be defective in material or workmanship under normal use for the applicable period stated above.
- (2) Warranty repairs will be made by your Amano Pioneer Eclipse Corporation Distributor without charge for parts and labor. They will be compensated with a warranty labor rate of \$45.00 per hour, for the first year of ownership.
- (3) Parts repaired or replaced under this warranty are warranted only during the balance of the original warranty period. All defective parts replaced under these warranties become the property of Amano Pioneer Eclipse Corporation.

WARRANTY SERVICE

To obtain warranty service, take your machine and proof of purchase to any authorized Amano Pioneer Eclipse Corporation Distributor. Amano Pioneer Eclipse Corporation will not reimburse expenses for service calls or travel. For the Distributor in your area, call Amano Pioneer Eclipse Corporation Customer Service Department at 1-800-367-3550 or 1-336-372-8080. If you are dissatisfied with the service that you receive, call or email Amano Pioneer Eclipse Corporation Customer Service Department at apeccs@pioneer-eclipse.com for further assistance.

INSTRUCTIONS AND CONDITIONS FOR WARRANTY REIMBURSEMENT

- Order replacement part: Orders will be processed and charged, as normal procedure.
- Call Amano Pioneer Eclipse Corporation for R/A number.
- You will need the Engine Serial Number, Machine Serial Number, and the Machine Model Number.
- Parts must be returned, accompanied with the R/A number to be eligible for warranty credit.
- All Warranty Parts will be shipped prepaid UPS Ground, any other method will be at the recipients expense.
- Freight on any Warranty Part after 30 days must be paid for by the Purchaser.
- Warranty labor rate is \$45.00 per hour.
- Credit will be issued upon completion of the above steps, at the above rates.

DISCLAIMER OF CONSEQUENTIAL

AMANO PIONEER ECLIPSE CORPORATION DISCLAIMS ANY RESPONSIBILITY FOR LOSS OF USER TIME OF THE AMANO PIONEER ECLIPSE CORPORATION MACHINE OR ANY OTHER INCIDENTAL OR CONSEQUENTIAL DAMAGE EXCEPT AS STATED IN THE WARRANTY APPLICABLE TO EACH MACHINE. EXCEPT AS STATED IN SUCH WARRANTIES, THE COMPANY DOES NOT OTHERWISE WARRANT ANY MACHINE AND NO WARRANTY, EXPRESS, IMPLIED OR STATUTORY IS MADE BY THE COMPANY.

Copyright 2016 Amano Pioneer Eclipse Corporation



Amano Pioneer Eclipse Corporation

1 Eclipse Rd ● PO Box 909
Sparta, North Carolina 28675 ● USA
www.pioneereclipse.com

+1-336-372-8080
1-800-367-3550
Fax +1-336-372-2913